



Wide-Area Networking Configuration Guide: Frame Relay, Cisco IOS Release 12.4T

Americas Headquarters

Cisco Systems, Inc.
170 West Tasman Drive
San Jose, CA 95134-1706
USA
<http://www.cisco.com>
Tel: 408 526-4000
800 553-NETS (6387)
Fax: 408 527-0883

THE SPECIFICATIONS AND INFORMATION REGARDING THE PRODUCTS IN THIS MANUAL ARE SUBJECT TO CHANGE WITHOUT NOTICE. ALL STATEMENTS, INFORMATION, AND RECOMMENDATIONS IN THIS MANUAL ARE BELIEVED TO BE ACCURATE BUT ARE PRESENTED WITHOUT WARRANTY OF ANY KIND, EXPRESS OR IMPLIED. USERS MUST TAKE FULL RESPONSIBILITY FOR THEIR APPLICATION OF ANY PRODUCTS.

THE SOFTWARE LICENSE AND LIMITED WARRANTY FOR THE ACCOMPANYING PRODUCT ARE SET FORTH IN THE INFORMATION PACKET THAT SHIPPED WITH THE PRODUCT AND ARE INCORPORATED HEREIN BY THIS REFERENCE. IF YOU ARE UNABLE TO LOCATE THE SOFTWARE LICENSE OR LIMITED WARRANTY, CONTACT YOUR CISCO REPRESENTATIVE FOR A COPY.

The Cisco implementation of TCP header compression is an adaptation of a program developed by the University of California, Berkeley (UCB) as part of UCB's public domain version of the UNIX operating system. All rights reserved. Copyright © 1981, Regents of the University of California.

NOTWITHSTANDING ANY OTHER WARRANTY HEREIN, ALL DOCUMENT FILES AND SOFTWARE OF THESE SUPPLIERS ARE PROVIDED "AS IS" WITH ALL FAULTS. CISCO AND THE ABOVE-NAMED SUPPLIERS DISCLAIM ALL WARRANTIES, EXPRESSED OR IMPLIED, INCLUDING, WITHOUT LIMITATION, THOSE OF MERCHANTABILITY, FITNESS FOR A PARTICULAR PURPOSE AND NON-INFRINGEMENT OR ARISING FROM A COURSE OF DEALING, USAGE, OR TRADE PRACTICE.

IN NO EVENT SHALL CISCO OR ITS SUPPLIERS BE LIABLE FOR ANY INDIRECT, SPECIAL, CONSEQUENTIAL, OR INCIDENTAL DAMAGES, INCLUDING, WITHOUT LIMITATION, LOST PROFITS OR LOSS OR DAMAGE TO DATA ARISING OUT OF THE USE OR INABILITY TO USE THIS MANUAL, EVEN IF CISCO OR ITS SUPPLIERS HAVE BEEN ADVISED OF THE POSSIBILITY OF SUCH DAMAGES.

Cisco and the Cisco Logo are trademarks of Cisco Systems, Inc. and/or its affiliates in the U.S. and other countries. A listing of Cisco's trademarks can be found at www.cisco.com/go/trademarks. Third party trademarks mentioned are the property of their respective owners. The use of the word partner does not imply a partnership relationship between Cisco and any other company. (1005R)

Any Internet Protocol (IP) addresses and phone numbers used in this document are not intended to be actual addresses and phone numbers. Any examples, command display output, network topology diagrams, and other figures included in the document are shown for illustrative purposes only. Any use of actual IP addresses or phone numbers in illustrative content is unintentional and coincidental.

© 2011 Cisco Systems, Inc. All rights reserved.



CONTENTS

Wide-Area Networking Overview 1

Finding Feature Information 1

Frame Relay 1

 Frame Relay-ATM Internetworking 4

Switched Multimegabit Data Service 4

Link Access Procedure - Balanced and X.25 5

Layer 2 Virtual Private Network 6

 Layer 2 Tunneling Protocol Version 3 7

 L2VPN Pseudowire Redundancy 7

 Layer 2 Virtual Private Network Interworking 7

 Layer 2 Local Switching 7

Wide Area Application Services 7

Configuring Frame Relay 9

Finding Feature Information 9

Information About Frame Relay 9

 Cisco Frame Relay MIB 10

 Frame Relay Hardware Configurations 10

 Frame Relay Encapsulation 11

 Dynamic or Static Address Mapping 11

 Dynamic Address Mapping 11

 Static Address Mapping 11

 LMI 11

 Activating LMI Autosense 12

 Status Request 12

 Status Messages 12

 LMI Autosense 12

 Configuration Options 12

 Frame Relay SVCs 13

 Operating SVCs 13

Frame Relay Traffic Shaping	13
Defining VCs for Different Types of Traffic	14
Frame Relay ForeSight	14
Frame Relay ForeSight Prerequisites	14
Frame Relay Congestion Notification Methods	15
Enhanced Local Management Interface	15
ELMI QoS Autosense	15
ELMI Address Registration	16
Traffic-Shaping Map Class for the Interface	17
Specifying Map Class with Queuing and Traffic-Shaping Parameters	17
Defining Access Lists	17
Defining Priority Queue Lists for the Map Class	17
Defining Custom Queue Lists for the Map Class	17
Frame Relay Switching	17
Frame Relay Switching over ISDN B Channels	18
Frame Relay Traffic Shaping on Switched PVCs	19
Traffic Policing	19
Congestion Management on Switched PVCs	20
FRF.12 Fragmentation on Switched PVCs	20
Frame Relay End-to-End Keepalives	21
PPP over Frame Relay	22
Understanding Frame Relay Subinterfaces	23
Subinterface Addressing	25
Point-to-Point Subinterfaces	26
Addressing on Multipoint Subinterfaces	26
Backup Interface for a Subinterface	26
Disabling or Reenabling Frame Relay Inverse ARP	27
Broadcast Queue for an Interface	27
Frame Relay Fragmentation	27
End-to-End FRF.12 Fragmentation	28
Setting the Fragment Size	28
Frame Relay Fragmentation Using FRF.11 Annex C	28
Cisco-Proprietary Fragmentation	29
Frame Relay Fragmentation and Hardware Compression Interoperability	29
Frame Relay Fragmentation Conditions and Restrictions	29

Payload Compression	30
Packet-by-Packet Payload Compression	30
Standard-Based FRF.9 Compression	30
Selecting FRF.9 Compression Method	30
Cisco-proprietary Data-Stream Compression	31
TCP IP Header Compression	31
Specifying an Individual IP Map for TCP IP Header Compression	31
Specifying an Interface for TCP IP Header Compression	31
Real-Time Header Compression with Frame Relay Encapsulation	32
Discard Eligibility	32
DLCI Priority Levels	32
How to Configure Frame Relay	33
Enabling Frame Relay Encapsulation on an Interface	33
Configuring Static Address Mapping	33
Explicitly Configuring the LMI	34
Setting the LMI Type	34
Setting the LMI Keepalive Interval	35
Setting the LMI Polling and Timer Intervals	35
Enabling Frame Relay SVC Service	35
Configuring SVCs on a Physical Interface	35
Configuring SVCs on a Subinterface	36
Configuring a Map Class	37
Configuring a Map Group with E.164 or X.121 Addresses	38
Associating the Map Class with Static Protocol Address Maps	39
Configuring LAPF Parameters	39
Changing Layer 2 Parameters for Your Network	39
Configuring Frame Relay Traffic Shaping	40
Enabling Frame Relay Traffic Shaping on the Interface	40
Configuring Enhanced Local Management Interface	41
Enabling ELMI	41
Disabling Automatic IP Address Selection	41
Configuring the IP Address to Be Used for ELMI Address Registration	42
Enabling ELMI Address Registration on an Interface	42
Verifying ELMI Address Registration	42
Specifying a Traffic-Shaping Map Class for the Interface	42

Defining a Map Class with Queuing and Traffic-Shaping Parameters	43
Configuring Frame Relay Switching	43
Enabling Frame Relay Switching	44
Configuring a Frame Relay DTE Device or DCE Switch or NNI Support	44
Creating Switched PVC over ISDN	44
Creating a Switched PVC with Static Route	44
Identifying a PVC As Switched	45
Configuring Traffic Policing on UNI DCE Devices	45
Enabling Frame Relay Policing	45
Configuring Frame Relay Policing Parameters	45
Configuring Congestion Management on Switched PVCs	46
Configuring Frame Relay Congestion Management on the Interface	46
Configuring Frame Relay Congestion Management on Traffic-Shaping Queues	46
Configuring FRF.12 Fragmentation on Switched PVCs	47
Verifying Frame Relay Switching	47
Troubleshooting Frame Relay Switching	47
Customizing Frame Relay for Your Network	48
Configuring Frame Relay End-to-End Keepalives	48
Configuring End-to-End Keepalives	48
Modifying the Default Parameters	49
Verifying Frame Relay End-to-End Keepalives	49
Enabling PPP over Frame Relay	50
Configuring Frame Relay Subinterfaces	50
Configuring Subinterfaces	50
Defining Subinterface Addressing on Point-to-Point Subinterfaces	50
Accepting Inverse ARP for Dynamic Address Mapping on Multipoint Subinterfaces	51
Configuring Static Address Mapping on Multipoint Subinterfaces	51
Configuring Transparent Bridging for Point-to-Point Subinterfaces	52
Configuring Transparent Bridging for Point-to-Multipoint Interfaces	52
Configuring a Backup Interface for a Subinterface	53
Disabling or Reenabling Frame Relay Inverse ARP	53
Creating a Broadcast Queue for an Interface	54
Configuring Frame Relay Fragmentation	54
Configuring End-to-End FRF.12 Fragmentation	54
Verifying the Configuration of End-to-End FRF.12 Fragmentation	54

Configuring Payload Compression	55
Configuring Payload Compression On a Multipoint Interface or Subinterface	55
Configuring Payload Compression On a Point-to-Point Interface or Subinterface	55
Configuring FRF.9 Compression Using Map Statements	55
Configuring FRF.9 Compression on the Subinterface	56
Configuring Data-Stream Hardware Compression and IP Header Compression on a Point-to-Point Subinterface	56
Configuring Data-Stream Hardware Compression and IP Header Compression on a Multipoint Subinterface	57
Verifying Payload Compression	58
Configuring TCP IP Header Compression	59
Configuring an Individual IP Map for TCP IP Header Compression	59
Configuring an Interface for TCP IP Header Compression	59
Disabling TCP IP Header Compression	59
Configuring Discard Eligibility	60
Defining a DE List	60
Defining a DE Group	60
Configuring DLCI Priority Levels	60
Monitoring and Maintaining the Frame Relay Connections	61
Configuration Examples for Frame Relay	61
Example IETF Encapsulation	62
Example IETF Encapsulation on the Interface	62
Example IETF Encapsulation on a Per-DLCI Basis	62
Example Static Address Mapping	62
Example Two Routers in Static Mode	62
Example AppleTalk Routing	63
Example DECnet Routing	63
Example IPX Routing	63
Example Subinterface	63
Example Basic Subinterface	64
Example Frame Relay Multipoint Subinterface with Dynamic Addressing	64
Example IPX Routes over Frame Relay Subinterfaces	64
Example Unnumbered IP over a Point-to-Point Subinterface	65
Example Transparent Bridging Using Subinterfaces	65
Example SVC Configuration	65

Example SVC Interface	66
Example SVC Subinterface	66
Example Frame Relay Traffic Shaping	66
Example Traffic Shaping with Three Point-to-Point Subinterfaces	67
Example Traffic Shaping with ForeSight	68
Example LMI Configuration	68
Example ELMI and Frame Relay Traffic Shaping	68
Example Configuring the IP Address for ELMI Address Registration	69
Example Disabling ELMI Address Registration on an Interface	69
Example Backward Compatibility	69
Example Booting from a Network Server over Frame Relay	70
Example Frame Relay Switching	70
Example PVC Switching Configuration	70
Example Pure Frame Relay DCE	71
Example Hybrid DTE DCE PVC Switching	72
Example Switching over an IP Tunnel	73
Example Frame Relay Switching over ISDN B Channels	75
Example Traffic Shaping on Switched PVCs	75
Example Traffic Policing on a UNI DCE	76
Example Congestion Management on Switched PVCs	76
Example Congestion Management on the Traffic-Shaping Queue of a Switched PVC	77
Example FRF.12 Fragmentation on a Switched PVC Configuration	77
Example Frame Relay End-to-End Keepalive	77
Example End-to-End Keepalive Bidirectional Mode with Default Configuration	78
Example End-to-End Keepalive Request Mode with Default Configuration	78
Example End-to-End Keepalive Request Mode with Modified Configuration	78
Example PPPoverFrameRelay	79
Example PPP over Frame Relay DTE	79
Example PPP over Frame Relay DCE	79
Example Frame Relay Fragmentation Configuration	80
Example FRF.12 Fragmentation	80
Example Frame Relay Fragmentation with Hardware Compression	80
Example Payload Compression Configuration	81
Example FRF.9 Compression for Subinterfaces Using the frame-relaymap Command	81
Example FRF.9 Compression for Subinterfaces	81

Example Data-Stream Hardware Compression with TCP IP Header Compression on a Point-to-Point Subinterface	81
Example Data-Stream Hardware Compression with TCP IP Header Compression on a Multipoint Subinterface	82
Example Data-Stream Hardware Compression with RTP Header Compression and Frame Relay Fragmentation	82
Example TCP IP Header Compression	82
Example IP Map with Inherited TCP IP Header Compression	82
Example Using an IP Map to Override TCP IP Header Compression	83
Example Disabling Inherited TCP IP Header Compression	83
Example Disabling Explicit TCP IP Header Compression	84
Additional References	84
Adaptive Frame Relay Traffic Shaping for Interface Congestion	87
Finding Feature Information	87
Feature Overview	87
Benefits	88
Restrictions	88
Related Features and Technologies	88
Related Documents	88
Supported Platforms	89
Supported Standards and MIBs and RFCs	89
Prerequisites	89
Configuration Tasks	90
Configuring Frame Relay Adaptive Traffic Shaping	90
Verifying Frame Relay Adaptive Traffic Shaping	90
Configuration Examples	92
Example Frame Relay Adaptive Traffic Shaping for Interface Congestion	92
Glossary	92
Frame Relay 64-Bit Counters	95
Finding Feature Information	95
Feature Overview	96
Benefits	96
Restrictions	96
Related Documents	96
Supported Platforms	96
Supported Standards and MIBs and RFCs	97

Prerequisites	97
Configuration Tasks	97
Enabling Frame Relay Interfaces for 64-Bit Interface MIB Counters	98
Monitoring and Maintaining Frame Relay 64-Bit Counters	98
Configuration Examples	99
Enabling Slower Frame Relay Interfaces and Subinterfaces for 64-Bit Interface MIB Counters Example	99
Enabling Only Slower Frame Relay Subinterfaces for 64-Bit Interface MIB Counters Example	100
Frame Relay MIB Enhancements	103
Finding Feature Information	103
Prerequisites for Frame Relay MIB Enhancements	103
Information About Frame Relay MIB Enhancements	103
Feature Overview	104
Benefits	105
Related Documents	105
Supported Platforms	105
Supported Standards and MIBs and RFCs	105
How to Configure Frame Relay MIB Enhancements	106
Setting the Load Interval for a PVC	106
Verifying the Load Interval	106
Configuration Examples for Frame Relay MIB Enhancements	106
Example Setting the Load Interval for a PVC	107
Feature Information for Frame Relay MIB Enhancements	107
Frame Relay Point-Multipoint Wireless	109
Finding Feature Information	109
Feature Overview	109
Benefits	110
Restrictions	110
Related Features and Technologies	110
Related Documents	111
Supported Platforms	111
Supported Standards and MIBs and RFCs	111
Prerequisites	112
Configuration Tasks	112
Creating the Virtual Frame Relay Interface	112

Verifying Virtual Frame Relay	113
Troubleshooting Tips	113
Configuration Examples	113
Headend Example	113
Subscriber Unit Example	114
Frame Relay Queueing and Fragmentation at the Interface	117
Finding Feature Information	117
Prerequisites for Frame Relay Queueing and Fragmentation at the Interface	117
Restrictions for Frame Relay Queueing and Fragmentation at the Interface	118
Information About Frame Relay Queueing and Fragmentation at the Interface	118
How Frame Relay Queueing and Fragmentation at the Interface Works	118
Benefits of Frame Relay Queueing and Fragmentation at the Interface	119
How to Configure Frame Relay Queueing and Fragmentation at the Interface	119
Configuring Class Policy for the Priority Queue	120
Configuring Class Policy for the Bandwidth Queues	121
Configuring the Shaping Policy Using the Class-Default Class	122
Configuring Queueing and Fragmentation on the Frame Relay Interface	123
Verifying Frame Relay Queueing and Fragmentation at the Interface	125
Monitoring and Maintaining Frame Relay Queueing and Fragmentation at the Interface	127
Configuration Examples for Frame Relay Queueing and Fragmentation at the Interface	128
Example Frame Relay Queueing Shaping and Fragmentation at the Interface	128
Example Frame Relay Queueing and Fragmentation at the Interface	129
Additional References	129
Feature Information for Frame Relay Queueing and Fragmentation at the Interface	130
Frame Relay PVC Bundles with QoS Support for IP and MPLS	133
Finding Feature Information	133
Prerequisites for Frame Relay PVC Bundles with QoS Support for IP and MPLS	134
Restrictions for Frame Relay PVC Bundles with QoS Support for IP and MPLS	134
Information About Frame Relay PVC Bundles with QoS Support for IP and MPLS	134
Benefits of Frame Relay PVC Bundles with QoS Support for IP and MPLS	134
Frame Relay PVC Bundle Support	135
Service Levels and PVC Selection Criteria	135
Frame Relay PVC Bundle Management	136
Traffic Bumping	136
PVC-Bundle Protection Rules	136

MPLS EXP-based Mapping	137
How to Configure Frame Relay PVC Bundles with QoS Support for IP and MPLS	137
Configuring Frame Relay PVC Bundles with IP QoS Support	137
Configuring Frame Relay PVC Bundles with MPLS QoS Support	142
Verifying Frame Relay PVC Bundles Configuration	147
Monitoring and Maintaining Frame Relay PVC Bundles	148
Configuration Examples for Frame Relay PVC Bundles with QoS Support for IP and MPLS	149
PVC Bundles with IP QoS Support on Interfaces Example	149
PVC Bundle with IP QoS Support with Multiple QoS Parameters Example	151
PVC Bundle with MPLS QoS Support Example	151
Verifying Frame Relay PVC Bundle Configuration Examples	152
Monitoring and Maintaining Frame Relay PVC Bundles Examples	154
Additional References	155
Feature Information for Frame Relay PVC Bundles with QoS Support for IP and MPLS	156
Glossary	157
Frame Relay Voice-Adaptive Traffic Shaping and Fragmentation	159
Finding Feature Information	159
Prerequisites for Frame Relay Voice-Adaptive Traffic Shaping and Fragmentation	160
Restrictions for Frame Relay Voice-Adaptive Traffic Shaping and Fragmentation	160
Information About Frame Relay Voice-Adaptive Traffic Shaping and Fragmentation	160
Benefits of Frame Relay Voice-Adaptive Traffic Shaping and Fragmentation	160
Frame Relay Voice-Adaptive Traffic Shaping	161
Frame Relay Voice-Adaptive Fragmentation	161
How to Configure Frame Relay Voice-Adaptive Traffic Shaping and Fragmentation	161
Configuring Class Policy for the Priority Queue and Bandwidth Queues	162
Configuring Frame Relay Voice-Adaptive Traffic Shaping Using the Class-Default Class	163
Configuring a Map Class for Frame Relay Voice-Adaptive Traffic Shaping and Fragmentation	165
Enabling Frame Relay Voice-Adaptive Traffic Shaping and Fragmentation on the Interface	166
Verifying Frame Relay Voice-Adaptive Traffic Shaping and Fragmentation	168
Configuration Examples for Frame Relay Voice-Adaptive Traffic Shaping and Fragmentation	169
Frame Relay Voice-Adaptive Traffic Shaping and Fragmentation Examples	170
Verifying Frame Relay Voice-Adaptive Traffic Shaping and Fragmentation Example	171
Additional References	172
Frame Relay IP RTP Priority	175

Finding Feature Information	175
Feature Overview	175
Benefits	176
Related Features and Technologies	176
Related Documents	176
Supported Platforms	176
Supported Standards and MIBs and RFCs	176
Prerequisites	177
Configuration Tasks	177
Configuring Frame Relay IP RTP Priority	177
Verifying Frame Relay IP RTP Priority	177
Monitoring and Maintaining Frame Relay IP RTP Priority	178
Configuration Examples	178
Frame Relay IP RTP Priority Configuration Example	178
PPP over Frame Relay	181
Finding Feature Information	181
Prerequisites for PPP over Frame Relay	181
Restrictions for PPP over Frame Relay	181
Information About PPP over Frame Relay	182
Overview of PPP over Frame Relay	182
Benefits	183
How to Configure PPP over Frame Relay	183
Enabling PPP over Frame Relay	183
Configuration Examples for PPP over Frame Relay	184
Example PPP over Frame Relay DTE	184
Example PPP over Frame Relay DCE	185
Additional References	185
Feature Information for PPP over Frame Relay	186
Glossary	187
MQC-Based Frame Relay Traffic Shaping	189
Finding Feature Information	189
Prerequisites for MQC-Based Frame Relay Traffic Shaping	189
Restrictions for MQC-Based Frame Relay Traffic Shaping	190
Information About MQC-Based Frame Relay Traffic Shaping	190
MQC Overview	190

FRTS Overview	191
Feature Design of MQC-Based Frame Relay Traffic Shaping	191
Supported MQC Frame Relay Traffic Shaping Commands	192
Benefits of MQC-Based Frame Relay Traffic Shaping	192
How to Configure MQC-Based Frame Relay Traffic Shaping	192
Creating a Class Map and Specifying Match Criteria for CBWFQ	193
Creating a Policy Map and Entering CBWFQ Parameters for the Class Map	194
Creating a Shaping Policy Map and Entering FRTS Values for the Default Class Map	195
Attaching the Class-Based Weighted Fair Queueing Policy Map to the Shaping Policy Map	197
Specifying a Map Class and Attaching a Service Policy for the PVC	198
Configuring an Interface or Subinterface for Frame Relay and Associating a Map Class with a PVC	199
Defining Fragmentation Parameters for the PVC	201
Adding the Policy Map to the Map Class	202
Configuration Examples for MQC-Based Frame Relay Traffic Shaping	204
Example Configuring Class-Based Weighted Fair Queueing	204
Example Configuring Class-Based Weighted Fair Queueing with Fragmentation	204
Additional References	205
Feature Information for MQC-Based Frame Relay Traffic Shaping	206
Frame Relay PVC Interface Priority Queueing	207
Finding Feature Information	207
Feature Overview	207
Benefits	208
Restrictions	208
Related Features and Technologies	208
Related Documents	209
Supported Platforms	209
Supported Standards and MIBs and RFCs	209
Prerequisites	209
Configuration Tasks	210
Configuring PVC Priority in a Map Class	210
Enabling FR PIPQ and Setting Queue Limits	210
Assigning a Map Class to a PVC	211
Verifying FR PIPQ	211

Monitoring and Maintaining FR PIPQ	211
Configuration Examples	212
FR PIPQ Configuration Example	212
Glossary	213
Multilink Frame Relay FRF.16.1	215
Finding Feature Information	215
Prerequisites for Multilink Frame Relay FRF.16.1	215
Restrictions for Multilink Frame Relay FRF.16.1	215
Information About Multilink Frame Relay FRF.16.1	216
Benefits of Multilink Frame Relay FRF.16.1	216
Link Integrity Protocol Control Messages	216
Variable Bandwidth Class Support	216
Load Balancing with Multilink Frame Relay FRF.16.1	217
How to Enable Multilink Frame Relay FRF.16.1	217
Configuring a Multilink Frame Relay Bundle	217
Configuring a Multilink Frame Relay Bundle Link	221
Monitoring and Maintaining Multilink Frame Relay FRF.16.1	223
Configuration Examples for Multilink Frame Relay FRF.16.1	225
Configuring Multilink Frame Relay Example	225
Configuring Variable Bandwidth Class Support Example	226
Additional References	226
Feature Information for Multilink Frame Relay FRF.16.1	227
Glossary	228
Distributed Multilink Frame Relay FRF.16	231
Finding Feature Information	231
Feature Overview	232
Multilink Frame Relay Bundles and Bundle Links	232
Link Integrity Protocol Control Messages	232
Load Balancing	233
Benefits	233
Restrictions	233
Related Documents	233
Supported Platforms	234
Supported Standards MIBs and RFCs	235
Prerequisites	235

Configuration Tasks	235
Configuring a Multilink Frame Relay Bundle	236
Configuring a Multilink Frame Relay Bundle Link	236
Verifying Multilink Frame Relay	237
Monitoring and Maintaining Distributed Multilink Frame Relay	238
Configuration Examples	239
Distributed Multilink Frame Relay Configuration Example	239
Glossary	239
Frame Relay show Command and debug Command Enhancements	241
Finding Feature Information	241
Information About Frame Relay show Command and debug Command Enhancements	241
Overview of the Frame Relay show Command and debug Command Enhancements	241
Benefits of the Frame Relay Show Command and Debug Command Enhancements	242
Additional References	242
Feature Information for Frame Relay show Command and debug Command Enhancements	243
Configuring Frame Relay-ATM Interworking	245
Finding Feature Information	245
Prerequisites	246
Information About Frame Relay-ATM Interworking	246
FRF.5 Frame Relay-ATM Network Interworking	246
FRF.8 Frame Relay-ATM Service Interworking	247
How to Configure Frame Relay-ATM Interworking	247
Configuring and Verifying FRF.5	247
Configuring an FRF.5 One-to-One Network Interworking Connection	247
Configuring an FRF.5 Many-to-One Network Interworking Connection	249
Verifying FRF.5 Configuration	250
Configuring and Verifying FRF.8	251
Configuring an FRF.8 Service Interworking Connection	252
Verifying FRF.8 Configuration	253
Monitoring and Maintaining Frame Relay-to-ATM Interworking	255
Configuration Examples for Frame Relay-ATM Interworking	255
FRF.5 One-to-One Connection Example	255
FRF.5 Many-to-One Connection Example	256
FRF.8 Service Interworking Example	256



Wide-Area Networking Overview

Cisco IOS software provides a range of wide-area networking capabilities to fit almost every network environment need. Cisco offers cell relay via the Switched Multimegabit Data Service (SMDS), circuit switching via ISDN, packet switching via Frame Relay, and the benefits of both circuit and packet switching via Asynchronous Transfer Mode (ATM). LAN emulation (LANE) provides connectivity between ATM and other LAN types. The *Cisco IOS Wide-Area Networking Configuration Guide* presents a set of general guidelines for configuring the following software components:

This module gives a high-level description of each technology. For specific configuration information, see the appropriate module.

- [Finding Feature Information, page 1](#)
- [Frame Relay, page 1](#)
- [Switched Multimegabit Data Service, page 4](#)
- [Link Access Procedure - Balanced and X.25, page 5](#)
- [Layer 2 Virtual Private Network, page 6](#)
- [Wide Area Application Services, page 7](#)

Finding Feature Information

Your software release may not support all the features documented in this module. For the latest feature information and caveats, see the release notes for your platform and software release. To find information about the features documented in this module, and to see a list of the releases in which each feature is supported, see the Feature Information Table at the end of this document.

Use Cisco Feature Navigator to find information about platform support and Cisco software image support. To access Cisco Feature Navigator, go to www.cisco.com/go/cfn. An account on Cisco.com is not required.

Frame Relay

The Cisco Frame Relay implementation currently supports routing on IP, DECnet, AppleTalk, XNS, Novell IPX, CLNS, Banyan VINES, and transparent bridging.

Although Frame Relay access was originally restricted to leased lines, dialup access is now supported. For more information about dialer profiles or legacy dial-on-demand routing (DDR), see the module Dial-on-Demand Routing Configuration.

To install software on a new router or access server by downloading software from a central server over an interface that supports Frame Relay, see the module Loading and Maintaining System Images.

To configure access between Systems Network Architecture (SNA) devices over a Frame Relay network, see the module *Configuring SNA Frame Relay Access Support*.

The Frame Relay software provides the following capabilities:

- Support for the three generally implemented specifications of Frame Relay Local Management Interfaces (LMIs):
 - The Frame Relay Interface joint specification produced by Northern Telecom, Digital Equipment Corporation, StrataCom, and Cisco Systems
 - The ANSI-adopted Frame Relay signal specification, T1.617 Annex D
 - The ITU-T-adopted Frame Relay signal specification, Q.933 Annex A
- Conformity to ITU-T I-series (ISDN) recommendation as I122, "Framework for Additional Packet Mode Bearer Services":
 - The ANSI-adopted Frame Relay encapsulation specification, T1.618
 - The ITU-T-adopted Frame Relay encapsulation specification, Q.922 Annex A
- Conformity to Internet Engineering Task Force (IETF) encapsulation in accordance with RFC 2427, except bridging.
- Support for a keepalive mechanism, a multicast group, and a status message, as follows:
 - The keepalive mechanism provides an exchange of information between the network server and the switch to verify that data is flowing.
 - The multicast mechanism provides the network server with a local data-link connection identifier (DLCI) and a multicast DLCI. This feature is specific to our implementation of the Frame Relay joint specification.
 - The status mechanism provides an ongoing status report on the DLCIs known by the switch.
- Support for both PVCs and SVCs in the same sites and routers.
 - SVCs allow access through a Frame Relay network by setting up a path to the destination endpoints only when the need arises and tearing down the path when it is no longer needed.
- Support for Frame Relay Traffic Shaping beginning with Cisco IOS Release 11.2. Traffic shaping provides the following:
 - Rate enforcement for individual circuits--The peak rate for outbound traffic can be set to the committed information rate (CIR) or some other user-configurable rate.
 - Dynamic traffic throttling on a per-virtual-circuit basis--When backward explicit congestion notification (BECN) packets indicate congestion on the network, the outbound traffic rate is automatically stepped down; when congestion eases, the outbound traffic rate is stepped up again.
 - Enhanced queueing support on a per-virtual circuit basis--Custom queueing, priority queueing, and weighted fair queueing can be configured for individual virtual circuits.
- Transmission of congestion information from Frame Relay to DECnet Phase IV and CLNS. This mechanism promotes forward explicit congestion notification (FECN) bits from the Frame Relay layer to upper-layer protocols after checking for the FECN bit on the incoming DLCI. Use this Frame Relay congestion information to adjust the sending rates of end hosts. FECN-bit promotion is enabled by default on any interface using Frame Relay encapsulation. No configuration is required.
- Support for Frame Relay Inverse ARP as described in RFC 1293 for the AppleTalk, Banyan VINES, DECnet, IP, and IPX protocols, and for native hello packets for DECnet, CLNP, and Banyan VINES. It allows a router running Frame Relay to discover the protocol address of a device associated with the virtual circuit.
- Support for Frame Relay switching, whereby packets are switched based on the DLCI--a Frame Relay equivalent of a Media Access Control (MAC)-level address. Routers are configured as a hybrid DTE switch or pure Frame Relay DCE access node in the Frame Relay network.

Frame Relay switching is used when all traffic arriving on one DLCI can be sent out on another DLCI to the same next-hop address. In such cases, the Cisco IOS software need not examine the frames individually to discover the destination address, and, as a result, the processing load on the router decreases.

The Cisco implementation of Frame Relay switching provides the following functionality:

- Switching over an IP tunnel
- Switching over Network-to-Network Interfaces (NNI) to other Frame Relay switches
- Local serial-to-serial switching
- Switching over ISDN B channels
- Traffic shaping on switched PVCs
- Congestion management on switched PVCs
- Traffic policing on User-Network Interface (UNI) DCE
- FRF.12 fragmentation on switched PVCs
- Support for *subinterfaces* associated with a physical interface. The software groups one or more PVCs under separate subinterfaces, which in turn are located under a single physical interface. See the Configuring Frame Relay module.
- Support for fast-path transparent bridging, as described in RFC 1490, for Frame Relay encapsulated serial and High-Speed Serial Interfaces (HSSIs) on all platforms.
- Support of the Frame Relay DTE MIB specified in RFC 1315. However, the error table is not implemented. To use the Frame Relay MIB, refer to your MIB publications.
- Support for Frame Relay fragmentation. Cisco has developed the following three types of Frame Relay fragmentation:
 - End-to-End FRF.12 Fragmentation

FRF.12 fragmentation is defined by the FRF.12 Implementation Agreement. This standard was developed to allow long data frames to be fragmented into smaller pieces (fragments) and interleaved with real-time frames. End-to-end FRF.12 fragmentation is recommended for use on PVCs that share links with other PVCs that are transporting voice and on PVCs transporting Voice over IP (VoIP).
 - Frame Relay Fragmentation Using FRF.11 Annex C

When VoFR (FRF.11) and fragmentation are both configured on a PVC, the Frame Relay fragments are sent in the FRF.11 Annex C format. This fragmentation is used when FRF.11 voice traffic is sent on the PVC, and it uses the FRF.11 Annex C format for data.

See the module Configuring Voice over Frame Relay in the *Cisco IOS Voice, Video, and Fax Configuration Guide* for configuration tasks and examples for Frame Relay fragmentation using FRF.11 Annex C.
 - Cisco Proprietary Fragmentation

Cisco proprietary fragmentation is used on data packets on a PVC that is also used for voice traffic.

See the module Configuring Voice over Frame Relay in the *Cisco IOS Voice, Video, and Fax Configuration Guide* for configuration tasks and examples for Cisco proprietary fragmentation.
- [Frame Relay-ATM Internetworking, page 4](#)

Frame Relay-ATM Internetworking

Cisco IOS software supports the Frame Relay Forum implementation agreements for Frame Relay-ATM Interworking. Frame Relay-ATM Interworking enables Frame Relay and ATM networks to exchange data, despite differing network protocols. There are two types of Frame Relay-ATM Interworking:

FRF.5 Frame Relay-ATM Network Interworking

FRF.5 provides network interworking functionality that allows Frame Relay end users to communicate over an intermediate ATM network that supports FRF.5. Multiprotocol encapsulation and other higher-layer procedures are transported transparently, just as they would be over leased lines.

FRF.5 describes network interworking requirements between Frame Relay Bearer Services and Broadband ISDN (BISDN) permanent virtual circuit (PVC) services.

The FRF.5 standard is defined by the Frame Relay Forum Document Number FRF.5: *Frame Relay/ATM PVC Network Interworking Implementation Agreement*. For information about which sections of this implementation agreement are supported by Cisco IOS software, see Frame Relay-ATM Interworking Supported Standards.

FRF.8 Frame Relay-ATM Service Interworking

FRF.8 provides service interworking functionality that allows a Frame Relay end user to communicate with an ATM end user. Traffic is translated by a protocol converter that provides communication among dissimilar Frame Relay and ATM equipment.

FRF.8 describes a one-to-one mapping between a Frame Relay PVC and an ATM PVC.

The FRF.8 standard is defined by the Frame Relay Forum Document Number FRF.8: *Frame Relay/ATM PVC Network Service Interworking Implementation Agreement*. For information about which sections of this implementation agreement are supported by Cisco IOS software, see Frame Relay-ATM Interworking Supported Standards.

Switched Multimegabit Data Service

The Cisco implementation of the SMDS protocol is based on cell relay technology as defined in the Bellcore Technical advisories, which are based on the IEEE 802.6 standard. We provide an interface to an SMDS network using DS1 or DS3 high-speed transmission facilities. Connection to the network is made through a device called an SDSU--an SMDS digital service unit (DSU). The SDSU attaches to a router or access server through a serial port. On the other side, the SDSU terminates the line.

The implementation of SMDS supports the IP, DECnet, AppleTalk, XNS, Novell IPX, Banyan VINES, and OSI internetworking protocols, and transparent bridging.

The implementation of SMDS also supports SMDS encapsulation over an ATM interface. For more information and for configuration tasks, see *Configuring ATM*.

Routing of AppleTalk, DECnet, IP, IPX, and ISO CLNS is fully dynamic; that is, the routing tables are determined and updated dynamically. Routing of the other supported protocols requires that you establish a static routing table of SMDS neighbors in a user group. Once this table is set up, all interconnected routers and access servers provide dynamic routing.

**Note**

When configuring IP routing over SMDS, you may need to make adjustments to accommodate split horizon effects. Refer to the Configuring EIGRP module for information about how Cisco software handles possible split horizon conflicts. By default, split horizon is *disabled* for SMDS networks.

The SMDS implementation includes multiple logical IP subnetworks support as defined by RFC 1209. This RFC describes routing IP over an SMDS cloud in which each connection is considered a host on one specific private network, and points to cases where traffic must transit from network to network.

The implementation of SMDS also provides the Data Exchange Interface (DXI) Version 3.2 with *heartbeat*. The heartbeat mechanism periodically generates a heartbeat poll frame.

When a multicast address is not available to a destination, pseudobroadcasting can be enabled to broadcast packets to those destinations using a unicast address.

Link Access Procedure - Balanced and X.25

X.25 is one of a group of specifications published by the ITU-T. These specifications are international standards that are formally called *Recommendations*. The ITU-T *Recommendation X.25* defines how connections between DTE and DCE are maintained for remote terminal access and computer communications. The X.25 specification defines protocols for two layers of the Open Systems Interconnection (OSI) reference model. The data link layer protocol defined is LAPB. The network layer is sometimes called the packet level protocol (PLP), but is commonly (although less correctly) referred to as the X.25 protocol.

The ITU-T updates its *Recommendations* periodically. The specifications dated 1980 and 1984 are the most common versions currently in use. Additionally, the International Standards Organization (ISO) has published ISO 7776:1986 as an equivalent to the LAPB standard, and ISO 8208:1989 as an equivalent to the ITU-T 1984 *Recommendation X.25* packet layer. The Cisco X.25 software follows the ITU-T 1984 *Recommendation X.25*, except for its Defense Data Network (DDN) and Blacker Front End (BFE) operation, which follow the ITU-T 1980 *Recommendation X.25*.

**Note**

The ITU-T carries out the functions of the former CCITT. The 1988 X.25 standard was the last published as a CCITT *Recommendation*. The first ITU-T *Recommendation* is the 1993 revision.

In addition to providing remote terminal access, The Cisco X.25 software provides transport for LAN protocols--IP, DECnet, XNS, ISO CLNS, AppleTalk, Novell IPX, Banyan VINES, and Apollo Domain--and bridging.

Cisco IOS X.25 software provides the following capabilities:

- LAPB datagram transport--LAPB is a protocol that operates at Level 2 (the data link layer) of the OSI reference model. It offers a reliable connection service for exchanging data (in units called *frames*) with one other host. The LAPB connection is configured to carry a single protocol or multiple protocols. Protocol datagrams (IP, DECnet, AppleTalk, and so forth) are carried over a reliable LAPB connection, or datagrams of several of these protocols are encapsulated in a proprietary protocol and carried over a LAPB connection. Cisco also implements transparent bridging over multiprotocol LAPB encapsulations on serial interfaces.
- X.25 datagram transport-- X.25 can establish connections with multiple hosts; these connections are called virtual circuits. Protocol datagrams (IP, DECnet, AppleTalk, and so forth) are encapsulated inside packets on an X.25 virtual circuit. Mappings between the X.25 address of a host and its

datagram protocol addresses enable these datagrams to be routed through an X.25 network, thereby permitting an X.25 PDN to transport LAN protocols.

- X.25 switch--X.25 calls can be routed based on their X.25 addresses either between serial interfaces on the same router (local switching) or across an IP network to another router, using X.25 over TCP (XOT). XOT encapsulates the X.25 packet level inside a TCP connection, allowing X.25 equipment to be connected via a TCP/IP-based network. The Cisco X.25 switching features provide a convenient way to connect X.25 equipment, but do not provide the specialized features and capabilities of an X.25 PDN.
- ISDN D channel--X.25 traffic over the D channel, using up to 9.6 kbps bandwidth, can be used to support many applications. For example, it may be required as a primary interface where low volume sporadic interactive traffic is the normal mode of operation. For information on how to configure X.25 on ISDN, refer to the modules *Configuring X.25 on ISDN* and *Configuring X.25 on ISDN Using AO/DI*.
- PAD--User sessions can be carried across an X.25 network using the packet assembler/disassembler (PAD) protocols defined by the ITU-T Recommendations X.3 and X.29.
- QLLC--The Cisco IOS software can use the Qualified Logical Link Control (QLLC) protocol to carry SNA traffic through an X.25 network.
- Connection-Mode Network Service (CMNS)--CMNS is a mechanism that uses OSI-based network service access point (NSAP) addresses to extend local X.25 switching to nonserial media (for example, Ethernet, FDDI, and Token Ring). This implementation provides the X.25 PLP over Logical Link Control, type 2 (LLC2) to allow connections over nonserial interfaces. The Cisco CMNS implementation supports services defined in ISO Standards 8208 (packet level) and 8802-2 (frame level).
- DDN and BFE X.25--The DDN-specified Standard Service is supported. The DDN X.25 Standard Service is the required protocol for use with DDN Packet-Switched Nodes (PSNs). The Defense Communications Agency (DCA) has certified the Cisco DDN X.25 Standard Service implementation for attachment to the DDN. The Cisco DDN implementation also includes Blacker Front End operation.
- X.25 MIB--Subsets of the specifications in *SNMP MIB Extension for X.25 LAPB* (RFC 1381) and *SNMP MIB Extension for the X.25 Packet Layer* (RFC 1382) are supported. The LAPB XID Table, X.25 Cleared Circuit Table, and X.25 Call Parameter Table are not implemented. All values are read-only. To use the X.25 MIB, refer to the RFCs.
- Closed User Groups (CUGs)--A CUG is a collection of DTE devices for which the network controls access between two members and between a member and a nonmember. An X.25 network can support up to 10,000 CUGs. CUGs allow various network subscribers (DTE devices) to be segregated into private subnetworks that have limited incoming or outgoing access.

The Cisco X.25 implementation does not support fast switching.

Layer 2 Virtual Private Network

L2VPN services are point-to-point. They provide Layer 2 point-to-point connectivity over either an MPLS or a pure IP (L2TPv3) core.

- [Layer 2 Tunneling Protocol Version 3, page 7](#)
- [L2VPN Pseudowire Redundancy, page 7](#)
- [Layer 2 Virtual Private Network Interworking, page 7](#)
- [Layer 2 Local Switching, page 7](#)

Layer 2 Tunneling Protocol Version 3

Layer 2 Tunneling Protocol Version 3 (L2TPv3) expands Cisco support of Layer 2 Virtual Private Networks (VPNs). L2TPv3 is an Internet Engineering Task Force (IETF) I2tpevt working group draft that provides several enhancements to L2TP for the capability to tunnel any Layer 2 payload over L2TP. Specifically, L2TPv3 defines the L2TP protocol for tunneling Layer 2 payloads over an IP core network using Layer 2 virtual private networks (VPNs).

L2VPN Pseudowire Redundancy

L2VPNs can provide pseudowire resiliency through their routing protocols. When connectivity between end-to-end PE routers fails, an alternative path to the directed LDP session and the user data can take over. However, there are some parts of the network where this rerouting mechanism does not protect against interruptions in service. The L2VPN Pseudowire Redundancy feature provides the ability to ensure that the CE2 router in can always maintain network connectivity, even if one or all the failures in the figure occur. The L2VPN Pseudowire Redundancy feature enables you to set up backup pseudowires. You can configure the network with redundant pseudowires (PWs) and redundant network elements.

Layer 2 Virtual Private Network Interworking

Layer 2 transport over MPLS and IP already exists for like-to-like attachment circuits, such as Ethernet-to-Ethernet or PPP-to-PPP. L2VPN Interworking builds on this functionality by allowing disparate attachment circuits to be connected. An interworking function facilitates the translation between the different Layer 2 encapsulations. The L2VPN Interworking feature supports Ethernet, 802.1Q (VLAN), Frame Relay, ATM AAL5, and PPP attachment circuits over MPLS and L2TPv3.

Layer 2 Local Switching

Local switching allows you to switch Layer 2 data between two interfaces of the same type (for example, ATM to ATM, or Frame Relay to Frame Relay) or between interfaces of different types (for example, Frame Relay to ATM) on the same router. The interfaces can be on the same line card or on two different cards. During these kinds of switching, the Layer 2 address is used, not any Layer 3 address. Same-port local switching allows you to switch Layer 2 data between two circuits on the same interface.

Wide Area Application Services

Cisco's WAAS Express software interoperates with WAN optimization headend applications from Cisco and improves WAN access and use by optimizing applications that require high bandwidth or are bound to a LAN, such as backup.

WAAS Express helps enterprises meet the following objectives:

- Complements the Cisco WAN optimization system by adding the capability to the branch routers.
- Provide branch office employees with LAN-like access to information and applications across a geographically distributed network.
- Minimize unnecessary WAN bandwidth consumption through the use of advanced compression algorithms.
- Virtualize print and other local services to branch office users.
- Improve application performance over the WAN by addressing the following common issues:

- Low data rates (constrained bandwidth)
- Slow delivery of frames (high network latency)
- Higher rates of packet loss (low reliability)

The Network Analysis Module (NAM) Performance Agent (PA) for WAAS Express analyzes and measures network traffic. The PA enables baselining, monitoring, and troubleshooting of application performance. The analysis and measurement of network traffic is done by the Measurement, Aggregation, and Correlation Engine (MACE). MACE performs the required measurements on a subset of traffic and exports the necessary metrics to a target.

Cisco and the Cisco Logo are trademarks of Cisco Systems, Inc. and/or its affiliates in the U.S. and other countries. A listing of Cisco's trademarks can be found at www.cisco.com/go/trademarks. Third party trademarks mentioned are the property of their respective owners. The use of the word partner does not imply a partnership relationship between Cisco and any other company. (1005R)

Any Internet Protocol (IP) addresses and phone numbers used in this document are not intended to be actual addresses and phone numbers. Any examples, command display output, network topology diagrams, and other figures included in the document are shown for illustrative purposes only. Any use of actual IP addresses or phone numbers in illustrative content is unintentional and coincidental.



Configuring Frame Relay

Feature History

Release	Modification
Cisco IOS	For information about feature support in Cisco IOS software, use Cisco Feature Navigator.

- [Finding Feature Information, page 9](#)
- [Information About Frame Relay, page 9](#)
- [How to Configure Frame Relay, page 33](#)
- [Configuration Examples for Frame Relay, page 61](#)
- [Additional References, page 84](#)

Finding Feature Information

Your software release may not support all the features documented in this module. For the latest feature information and caveats, see the release notes for your platform and software release. To find information about the features documented in this module, and to see a list of the releases in which each feature is supported, see the Feature Information Table at the end of this document.

Use Cisco Feature Navigator to find information about platform support and Cisco software image support. To access Cisco Feature Navigator, go to www.cisco.com/go/cfn. An account on Cisco.com is not required.

Information About Frame Relay

- [Cisco Frame Relay MIB, page 10](#)
- [Frame Relay Hardware Configurations, page 10](#)
- [Frame Relay Encapsulation, page 11](#)
- [Dynamic or Static Address Mapping, page 11](#)
- [LMI, page 11](#)
- [Frame Relay SVCs, page 13](#)
- [Frame Relay Traffic Shaping, page 13](#)
- [Frame Relay Switching, page 17](#)
- [Frame Relay End-to-End Keepalives, page 21](#)
- [PPP over Frame Relay, page 22](#)
- [Understanding Frame Relay Subinterfaces, page 23](#)

- [Disabling or Reenabling Frame Relay Inverse ARP](#), page 27
- [Broadcast Queue for an Interface](#), page 27
- [Frame Relay Fragmentation](#), page 27
- [Payload Compression](#), page 30
- [TCP/IP Header Compression](#), page 31
- [Real-Time Header Compression with Frame Relay Encapsulation](#), page 32
- [Discard Eligibility](#), page 32
- [DLCI Priority Levels](#), page 32

Cisco Frame Relay MIB

The Cisco Frame Relay MIB adds extensions to the standard Frame Relay MIB (RFC 1315). It provides additional link-level and virtual circuit (VC)-level information and statistics that are mostly specific to Cisco Frame Relay implementation. This MIB provides SNMP network management access to most of the information covered by the **show frame-relay** commands such as, **show frame-relay lmi**, **show frame-relay pvc**, **show frame-relay map**, and **show frame-relay svc**.

Frame Relay Hardware Configurations

You can create Frame Relay connections using one of the following hardware configurations:

- Routers and access servers connected directly to the Frame Relay switch
- Routers and access servers connected directly to a channel service unit/digital service unit (CSU/DSU), which then connects to a remote Frame Relay switch



Note

Routers can connect to Frame Relay networks either by direct connection to a Frame Relay switch or through CSU/DSUs. However, a single router interface configured for Frame Relay can be configured for only one of these methods.

The CSU/DSU converts V.35 or RS-449 signals to the properly coded T1 transmission signal for successful reception by the Frame Relay network. The figure below illustrates the connections among the components.

Figure 1 Typical Frame Relay Configuration

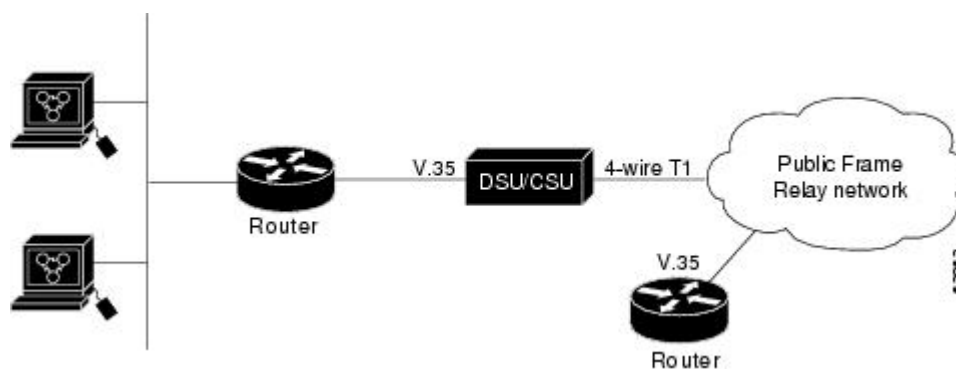

The Frame Relay interface actually consists of one physical connection between the network server and the switch that provides the service. This single physical connection provides direct connectivity to each device on a network.

Frame Relay Encapsulation

Frame Relay supports encapsulation of all supported protocols in conformance with RFC 1490, allowing interoperability among multiple vendors. Use the IETF form of Frame Relay encapsulation if your router or access server is connected to another vendor's equipment across a Frame Relay network. IETF encapsulation is supported either at the interface level or on a per-VC basis.

Shut down the interface prior to changing encapsulation types. Although shutting down the interface is not required, it ensures that the interface is reset for the new encapsulation.

Dynamic or Static Address Mapping

- [Dynamic Address Mapping, page 11](#)
- [Static Address Mapping, page 11](#)

Dynamic Address Mapping

Dynamic address mapping uses Frame Relay Inverse ARP to request the next-hop protocol address for a specific connection, given its known DLCI. Responses to Inverse ARP requests are entered in an address-to-DLCI mapping table on the router or access server; the table is then used to supply the next-hop protocol address or the DLCI for outgoing traffic.

Inverse ARP is enabled by default for all protocols it supports, but can be disabled for specific protocol-DLCI pairs. As a result, you can use dynamic mapping for some protocols and static mapping for other protocols on the same DLCI. You can explicitly disable Inverse ARP for a protocol-DLCI pair if you know that the protocol is not supported on the other end of the connection. For more information, see the [Disabling or Reenabling Frame Relay Inverse ARP](#) section.

**Note**

Because Inverse ARP is enabled by default, no additional command is required to configure dynamic mapping on an interface and packets are not sent out for protocols that are not enabled on the interface.

Static Address Mapping

A static map links a specified next-hop protocol address to a specified DLCI. Static mapping removes the need for Inverse ARP requests; when you supply a static map, Inverse ARP is automatically disabled for the specified protocol on the specified DLCI. You must use static mapping if the router at the other end either does not support Inverse ARP at all or does not support Inverse ARP for a specific protocol that you want to use over Frame Relay.

You can simplify the configuration for the Open Shortest Path First (OSPF) protocol by adding the optional **broadcast** keyword when doing this task. Refer to the **frame-relay map** command description in the *Cisco IOS Wide-Area Networking Command Reference* and the examples at the end of this chapter for more information about using the **broadcast** keyword.

LMI

The Cisco IOS software supports Local Management Interface (LMI) autosense, which enables the interface to determine the LMI type supported by the switch. Support for LMI autosense means that you are no longer required to configure the LMI explicitly.

LMI autosense is active in the following situations:

- The router is powered up or the interface changes state to up.
- The line protocol is down but the line is up.
- The interface is a Frame Relay DTE.
- The LMI type is not explicitly configured.
- [Activating LMI Autosense, page 12](#)

Activating LMI Autosense

- [Status Request, page 12](#)
- [Status Messages, page 12](#)
- [LMI Autosense, page 12](#)
- [Configuration Options, page 12](#)

Status Request

When LMI autosense is active, it sends out a full status request, in all three LMI types, to the switch. The order is ANSI, ITU, cisco, but it is done in rapid succession. Cisco IOS software provides the ability to listen in on both DLCI 1023 (cisco LMI) and DLCI 0 (ANSI and ITU) simultaneously.

Status Messages

One or more of the status requests will elicit a reply (status message) from the switch. The router will decode the format of the reply and configure itself automatically. If more than one reply is received, the router will configure itself with the type of the last received reply. This is to accommodate intelligent switches that can handle multiple formats simultaneously.

LMI Autosense

If LMI autosense is unsuccessful, an intelligent retry scheme is built in. Every N391 interval (default is 60 seconds, which is 6 keep exchanges at 10 seconds each), LMI autosense will attempt to ascertain the LMI type. For more information about N391, see the **frame-relay lmi-n391dte** command in the chapter "Frame Relay Commands" in the *Cisco IOS Wide-Area Networking Command Reference*.

The only visible indication to the user that LMI autosense is under way is that **debug frame lmi** is turned on. At every N391 interval, the user will now see three rapid status inquiries coming out of the serial interface: one in ANSI, one in ITU, and one in cisco LMI-type.

Configuration Options

No configuration options are provided; LMI autosense is transparent to the user. You can turn off LMI autosense by explicitly configuring an LMI type. The LMI type must be written into NVRAM so that next time the router powers up, LMI autosense will be inactive. At the end of autoinstall, a **frame-relay lmi-type xxx** statement is included within the interface configuration. This configuration is not automatically written to NVRAM; you must explicitly write the configuration to NVRAM by using the **copy system:running-config** or **copy nvram:startup-config** command.

Frame Relay SVCs

Access to Frame Relay networks is made through private leased lines at speeds ranging from 56 kbps to 45 Mbps. Frame Relay is a connection-oriented packet-transfer mechanism that establishes VCs between endpoints.

Switched virtual circuits (SVCs) allow access through a Frame Relay network by setting up a path to the destination endpoints only when the need arises and tearing down the path when it is no longer needed.

SVCs can coexist with PVCs in the same sites and routers. For example, routers at remote branch offices might set up PVCs to the central headquarters for frequent communication, but set up SVCs with each other as needed for intermittent communication. As a result, any-to-any communication can be set up without any-to-any PVCs.

On SVCs, quality of service (QoS) elements can be specified on a call-by-call basis to request network resources.

SVC support is offered in the Enterprise image on Cisco platforms that include a serial or HSSI interface.

You must have the following services before Frame Relay SVCs can operate:

- Frame Relay SVC support by the service provider--The service provider's switch must be capable of supporting SVC operation.
- Physical loop connection--A leased line or dedicated line must exist between the router (DTE) and the local Frame Relay switch.
- [Operating SVCs, page 13](#)

Operating SVCs

SVC operation requires that the Data Link layer (Layer 2) be set up, running ITU-T Q.922 Link Access Procedures to Frame mode bearer services (LAPF), prior to signalling for an SVC. Layer 2 sets itself up as soon as SVC support is enabled on the interface, if both the line and the line protocol are up. When the SVCs are configured and demand for a path occurs, the Q.933 signalling sequence is initiated. Once the SVC is set up, data transfer begins.

Q.922 provides a reliable link layer for Q.933 operation. All Q.933 call control information is transmitted over DLCI 0; this DLCI is also used for the management protocols specified in ANSI T1.617 Annex D or Q.933 Annex A.

You must enable SVC operation at the interface level. Once it is enabled at the interface level, it is enabled on any subinterfaces on that interface. One signalling channel, DLCI 0, is set up for the interface, and all SVCs are controlled from the physical interface.

Frame Relay Traffic Shaping

Traffic shaping applies to both PVCs and SVCs. Enabling Frame Relay traffic shaping on an interface enables both traffic shaping and per-VC queueing on all the PVCs and SVCs on the interface. Traffic shaping enables the router to control the circuit's output rate and react to congestion notification information if also configured.

**Note**

Frame Relay traffic shaping is not effective for Layer 2 PVC switching using the **frame-relay route** command.

- [Defining VCs for Different Types of Traffic, page 14](#)
- [Frame Relay ForeSight, page 14](#)
- [Frame Relay Congestion Notification Methods, page 15](#)
- [Enhanced Local Management Interface, page 15](#)
- [Traffic-Shaping Map Class for the Interface, page 17](#)
- [Specifying Map Class with Queueing and Traffic-Shaping Parameters, page 17](#)
- [Defining Access Lists, page 17](#)
- [Defining Priority Queue Lists for the Map Class, page 17](#)
- [Defining Custom Queue Lists for the Map Class, page 17](#)

Defining VCs for Different Types of Traffic

By defining separate VCs for different types of traffic and specifying queueing and an outbound traffic rate for each VC, you can provide guaranteed bandwidth for each type of traffic. By specifying different traffic rates for different VCs over the same line, you can perform virtual time division multiplexing. By throttling outbound traffic from high-speed lines in central offices to lower-speed lines in remote locations, you can ease congestion and data loss in the network; enhanced queueing also prevents congestion-caused data loss.

Frame Relay ForeSight

ForeSight is the network traffic control software used in some Cisco switches. The Cisco Frame Relay switch can extend ForeSight messages over a User-to-Network Interface (UNI), passing the backward congestion notification for VCs.

ForeSight allows Cisco Frame Relay routers to process and react to ForeSight messages and adjust VC level traffic shaping in a timely manner.

ForeSight must be configured explicitly on both the Cisco router and the Cisco switch. ForeSight is enabled on the Cisco router when Frame Relay traffic shaping is configured. However, the router's response to ForeSight is not applied to any VC until the **frame-relay adaptive-shaping foresight** command is added to the VCs map-class. When ForeSight is enabled on the switch, the switch will periodically send out a ForeSight message based on the time value configured. The time interval can range from 40 to 5000 milliseconds.

When a Cisco router receives a ForeSight message indicating that certain DLCIs are experiencing congestion, the Cisco router reacts by activating its traffic-shaping function to slow down the output rate. The router reacts as it would if it were to detect the congestion by receiving a packet with the backward explicit congestion notification (BECN) bit set.

When ForeSight is enabled, Frame Relay traffic shaping will adapt to ForeSight messages and BECN messages.

- [Frame Relay ForeSight Prerequisites, page 14](#)

Frame Relay ForeSight Prerequisites

For router ForeSight to work, the following conditions must exist on the Cisco router:

- Frame Relay traffic shaping must be enabled on the interface.
- The traffic shaping for a circuit is adapted to ForeSight.

The following additional condition must exist on the Cisco switch:

- The UNI connecting to the router is Consolidated Link Layer Management (CLLM) enabled, with the proper time interval specified.

Frame Relay router ForeSight is enabled automatically when you use the **frame-relay traffic-shaping** command. However, you must issue the **map-class frame-relay** command and the **frame-relay adaptive-shaping foresight** command before the router will respond to ForeSight and apply the traffic-shaping effect on a specific interface, subinterface, or VC.

Frame Relay Congestion Notification Methods

The difference between the BECN and ForeSight congestion notification methods is that BECN requires a user packet to be sent in the direction of the congested DLCI to convey the signal. The sending of user packets is not predictable and, therefore, not reliable as a notification mechanism. Rather than waiting for user packets to provide the congestion notification, timed ForeSight messages guarantee that the router receives notification before congestion becomes a problem. Traffic can be slowed down in the direction of the congested DLCI.

Enhanced Local Management Interface

Enhanced Local Management Interface (ELMI) allows the router to learn QoS parameters and connectivity information from the Cisco switch and to use this information for traffic shaping, configuration, or management purposes. ELMI simplifies the process of configuring traffic shaping on the router and reduces chances of specifying inconsistent or incorrect values when configuring the router. ELMI works between Cisco routers and Cisco switches (BPX and IGX platforms).

- [ELMI QoS Autosense, page 15](#)
- [ELMI Address Registration, page 16](#)

ELMI QoS Autosense

When used in conjunction with traffic shaping, ELMI enables the router to respond to changes in the network dynamically. ELMI enables automated exchange of Frame Relay QoS parameter information between the Cisco router and the Cisco switch. The figure below illustrates a Cisco switch and a Cisco router, both configured with ELMI enabled. The switch sends QoS information to the router, which uses it for traffic rate enforcement.

Figure 2 Enhanced Local Management Interface--Sent Between the Cisco Switch and the Cisco Router

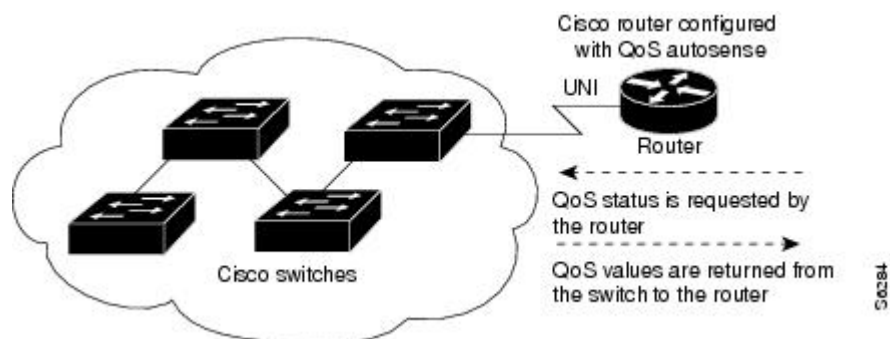

Routers can base congestion management and prioritization decisions on known QoS values, such as the Committed Information Rate (CIR), Committed Burst Size (Bc), and Excess Burst Size (Be). The router senses QoS values from the switch and can be configured to use those values in traffic shaping.

It is not necessary to configure traffic shaping on the interface to enable ELMI, but you may want to do so in order to know the values being used by the switch. If you want the router to respond to the QoS information received from the switch by adjusting the output rate, you must configure traffic shaping on the interface. To configure traffic shaping, use the **frame-relay traffic-shaping** command in interface configuration mode.

ELMI Address Registration

ELMI address registration enables a network management system (NMS) to detect connectivity among Cisco switches and routers in a network using the ELMI protocol. During ELMI version negotiation, neighboring devices exchange their management IP addresses and ifIndex. The NMS polls the devices and uses the Cisco Frame Relay MIB to collect this connectivity information. ELMI address registration allows for autodetection of the complete network topology.

The figure below shows a typical network in which ELMI address registration is in use.

Figure 3 Connectivity Detection Using ELMI Address Registration

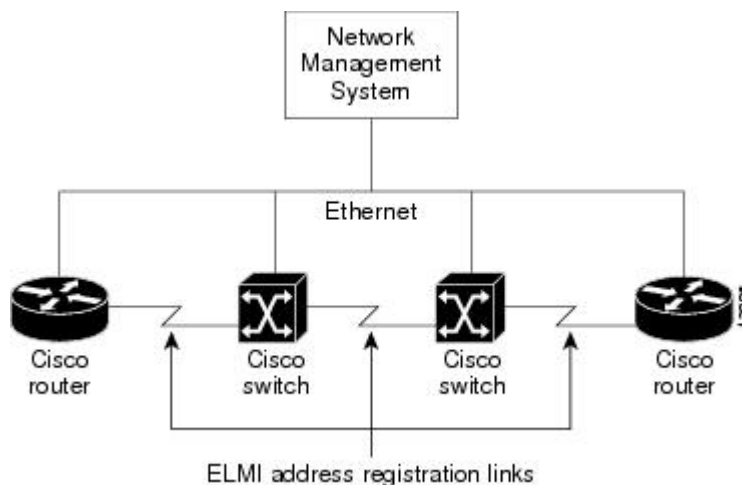

ELMI address registration takes place on all interfaces on which ELMI is enabled, even if all the interfaces are connected to the same router or switch. The router periodically sends a version inquiry message with version information, the management IP address, and ifIndex to the switch. The switch sends its management IP address and ifIndex using the version status message. When the management IP address of the switch changes, an asynchronous ELMI version status message is immediately sent to the neighboring device.



Note

The ELMI address registration mechanism does not check for duplicate or illegal addresses.

When ELMI is enabled, the router automatically chooses the IP address of one of the interfaces to use for ELMI address registration purposes. The router will choose the IP address of an Ethernet interface first, and then serial and other interfaces. You have the option to use the IP address chosen by the router or to disable the autoaddress mechanism and configure the management IP address yourself. You can also choose to disable ELMI address registration on a specific interface or on all interfaces.

Traffic-Shaping Map Class for the Interface

If you specify a Frame Relay map class for a main interface, all the VCs on its subinterfaces inherit all the traffic-shaping parameters defined for the class. You can override the default for a specific DLCI on a specific subinterface by using the **class VC** configuration command to assign the DLCI explicitly to a different class. See the section [Configuring Frame Relay Subinterfaces](#), page 50 for information about setting up subinterfaces.

For an example of assigning subinterface DLCIs to the default class and assigning others explicitly to a different class, see the section [Example Frame Relay Traffic Shaping](#), page 66.

Specifying Map Class with Queueing and Traffic-Shaping Parameters

When defining a map class for Frame Relay, you can specify the average and peak rates (in bits per second) allowed on VCs associated with the map class. You can also specify *either* a custom queue list *or* a priority queue group to use on VCs associated with the map class.

Defining Access Lists

You can specify access lists and associate them with the custom queue list defined for any map class. The list number specified in the access list and the custom queue list tie them together. See the appropriate protocol chapters for information about defining access lists for the protocols you want to transmit on the Frame Relay network.

Defining Priority Queue Lists for the Map Class

You can define a priority list for a protocol and you can also define a default priority list. The number used for a specific priority list ties the list to the Frame Relay priority group defined for a specified map class. For example, if you enter the **frame relay priority-group 2** command for the map class "fast_vcs" and then you enter the **priority-list 2 protocol decnet high** command, that priority list is used for the "fast_vcs" map class. The average and peak traffic rates defined for the "fast_vcs" map class are used for DECnet traffic.

Defining Custom Queue Lists for the Map Class

You can define a queue list for a protocol and a default queue list. You can also specify the maximum number of bytes to be transmitted in any cycle. The number used for a specific queue list ties the list to the Frame Relay custom queue list defined for a specified map class.

For example, if you enter the **frame relay custom-queue-list 1** command for the map class "slow_vcs" and then you enter the **queue-list 1 protocol ip list 100** command, that queue list is used for the "slow_vcs" map class; **access-list 100** definition is also used for that map class and queue. The average and peak traffic rates defined for the "slow_vcs" map class are used for IP traffic that meets the **access list 100** criteria.

Frame Relay Switching

Frame Relay switching is a means of switching packets based on the DLCI, which can be considered the Frame Relay equivalent of a MAC address. You perform switching by configuring your Cisco router or access server into a Frame Relay network. There are two parts to a Frame Relay network:

- Frame Relay DTE (the router or access server)
- Frame Relay DCE switch

The figure below illustrates Frame Relay switched networks. Routers A, B, and C are Frame Relay DTEs connected to each other via a Frame Relay network.

Figure 4 *Frame Relay Switched Network*

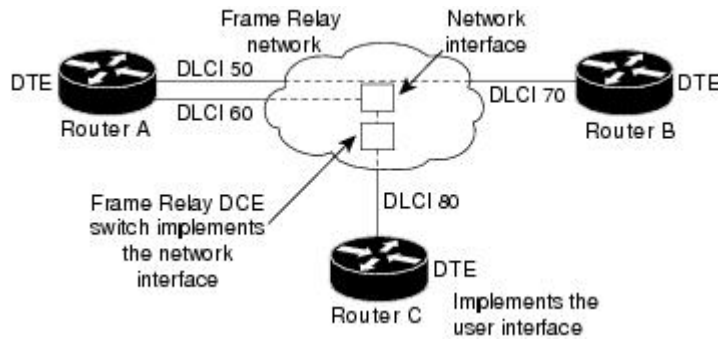

Frame Relay switching is supported on the following interface types:

- Serial interfaces
- ISDN interfaces



Note

Frame Relay switching is not supported on subinterfaces.

- [Frame Relay Switching over ISDN B Channels, page 18](#)
- [Frame Relay Traffic Shaping on Switched PVCs, page 19](#)
- [Traffic Policing, page 19](#)
- [Congestion Management on Switched PVCs, page 20](#)
- [FRF.12 Fragmentation on Switched PVCs, page 20](#)

Frame Relay Switching over ISDN B Channels

Frame Relay switching over ISDN B channels enables you to transport Frame Relay data over ISDN. This feature allows small offices to be hubbed out of larger offices rather than being connected directly to the core network. The hub router acts as a Frame Relay switch, switching between ISDN and serial interfaces, as shown in the figure below.

Figure 5 *Router Used As a Frame Relay Switch over ISDN*

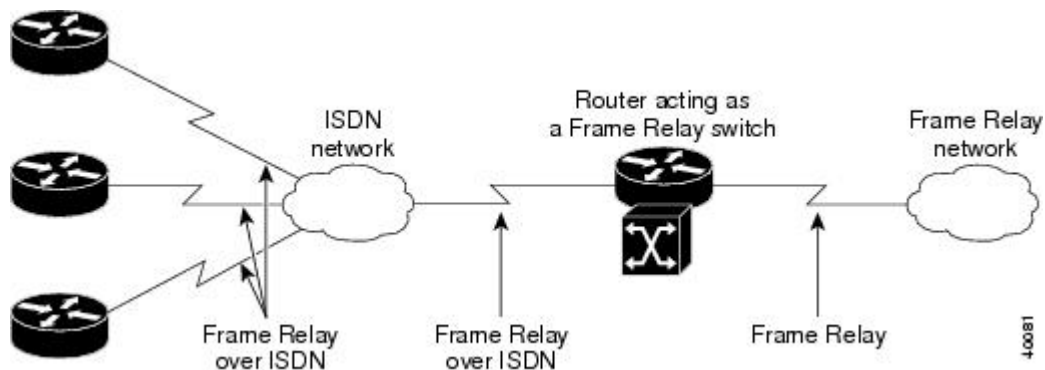

Frame Relay switching over ISDN provides the following functionality:

- LMI is supported on ISDN Frame Relay DCE interfaces.
- A single BRI/PRI interface can use a combination of switched PVCs and terminated Frame Relay PVCs.
- Frame Relay switching supports both leased-line ISDN, on which a B channel is permanently connected, and switched ISDN, on which B channels may be dynamically set up and torn down.

Note the following restrictions for Frame Relay switching over ISDN:

- Frame Relay traffic shaping is not supported on ISDN interfaces.
- The router configured for Frame Relay switching over ISDN cannot initiate the ISDN call.
- PVC-level congestion management is not supported over ISDN. Interface-level congestion management is supported.

When Frame Relay switching is performed by using a dialer profile, encapsulation of the underlying physical (BRI) interface must be configured as high-level data link control (HDLC).

Frame Relay Traffic Shaping on Switched PVCs

Applying Frame Relay traffic shaping to switched PVCs enables a router to be used as a Frame Relay port concentrator in front of a Frame Relay switch. The Frame Relay switch will shape the concentrated traffic before sending it into the network. The figure below shows the network configuration.

Figure 6 Router Used As a Frame Relay Port Concentrator

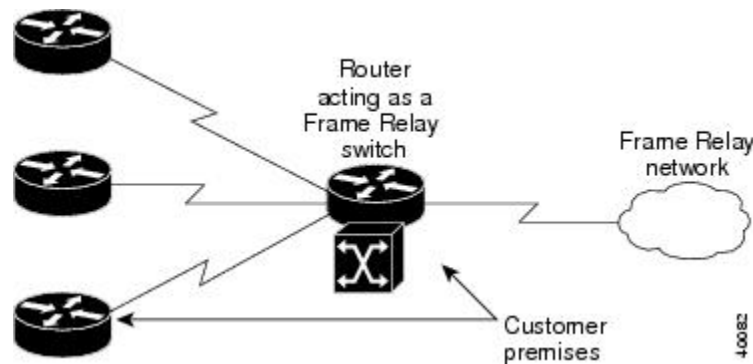

When you configure traffic shaping, you will define the traffic-shaping parameters in a Frame Relay map class and then attach the map class to the interface or a single switched PVC. All the traffic-shaping map-class parameters are applicable to switched PVCs: namely, Bc, Be, CIR, minimum CIR, average rate, peak rate, and adaptive shaping.

Frame Relay traffic shaping must be enabled on the interface before traffic-shaping map-class parameters will be effective. Note that when you enable Frame Relay traffic shaping, all PVCs, switched and terminated, will be shaped on that interface. Switched PVCs that are not associated with a map class will inherit shaping parameters from the interface or use default values.

Traffic Policing

Traffic policing prevents congestion on incoming PVCs by discarding or setting the DE bit on packets that exceed specified traffic parameters.

You can associate the map class with the interface or individual switched PVCs. Switched PVCs that are not associated with a map class will inherit policing parameters from the interface.

If you use a map class to configure both traffic policing and shaping, use the **in** keyword to specify incoming traffic for policing and the **out** keyword to specify outgoing traffic for shaping. If you configure shaping on one segment of a switched PVC and policing on the other, the shaping parameters will be derived from the policing parameters unless you specifically define shaping parameters in the map class.

Congestion Management on Switched PVCs

Frame Relay congestion management can be used to manage outgoing traffic congestion on switched PVCs. When Frame Relay congestion management is enabled, one way that the router manages congestion is by setting backward explicit congestion notification (BECN) and forward explicit congestion notification (FECN) bits on packets. When a switched PVC or interface is congested, packets experiencing congestion are marked with the FECN bit, and packets traveling in the reverse direction are marked with the BECN bit. When these bits reach a user device at the end of the network, the user device can react to the ECN bits and adjust the flow of traffic.

When the output interface queue reaches or exceeds the ECN excess threshold, Frame Relay bit packets on all PVCs crossing that interface will be marked with FECN or BECN, depending on their direction of travel. When the queue reaches or exceeds the ECN committed threshold, all Frame Relay packets will be marked with FECN or BECN.

A second way the router manages congestion is by discarding Frame Relay packets that are marked with the discard eligible (DE) bit and that exceed a specified level of congestion.

When the queue reaches or exceeds the DE threshold, Frame Relay packets with the DE bit will be discarded rather than queued.

You can define two levels of congestion. The first level applies to individual PVCs transmitting traffic in excess of the committed information rate (CIR). The second level applies to all PVCs at an interface. This scheme allows you to adjust the congestion on PVCs transmitting above the CIR before applying congestion management measures to all PVCs.

Congestion management parameters can be configured on the output interface queue and on traffic-shaping queues.

FRF.12 Fragmentation on Switched PVCs

The FRF.12 Implementation Agreement allows long data frames to be fragmented into smaller pieces. This process allows real-time traffic and non-real-time traffic to be carried together on lower-speed links without causing excessive delay to the real-time traffic. For further information about FRF.12 fragmentation, see the section [End-to-End FRF.12 Fragmentation](#), page 28 later in this module.

Some Frame Relay access devices do not support the FRF.12 standard for end-to-end fragmentation. Large packets sourced from these devices can cause significant serialization delay across low-speed trunks in switched networks. Using FRF.12 fragmentation can help prevent this delay. An edge router that receives large packets from a Frame Relay access device will fragment those packets before transmitting them across the switched network. The edge router that receives the fragmented packets will reassemble those packets before sending them to a Frame Relay access device that does not support FRF.12. If the receiving Frame Relay access device does support FRF.12, the router will transmit the fragmented packets without reassembling them.

Note the following conditions and restrictions on FRF.12 fragmentation on switched PVCs:

- Frame Relay traffic shaping must be enabled.
- Interface queueing must be dual FIFO queueing or PVC interface priority queueing.

- Switched PVCs must be configured using the **connect** command.
- If the Frame Relay access device does not support FRF.12 fragmentation, the FRF.12 Support on Switched Frame Relay PVCs feature will not benefit the interface between the Frame Relay access device and the edge router. Fragmentation and reassembly occur on the interface between the edge router and the switched Frame Relay network.
- If the Frame Relay access device is sending voice and unfragmented data on the same PVC, voice quality will suffer. The edge router will not reorder packets on switched PVCs.

Frame Relay End-to-End Keepalives

Frame Relay end-to-end keepalives enable monitoring of PVC status for network monitoring or backup applications and are configurable on a per-PVC basis with configurable timers. The Frame Relay switch within the local PVC segment deduces the status of the remote PVC segment through a Network-to-Network Interface (NNI) and reports the status to the local router. If LMI support within the switch is not end-to-end, end-to-end keepalives are the only source of information about the remote router. End-to-end keepalives verify that data is getting through to a remote device via end-to-end communication.

Each PVC connecting two end devices needs two separate keepalive systems, because the upstream path may not be the same as the downstream path. One system sends out requests and handles responses to those requests--the send side--while the other system handles and replies to requests from the device at the other end of the PVC--the receive side. The send side on one device communicates with the receive side on the other device, and vice versa.

The send side sends out a keepalive request and waits for a reply to its request. If a reply is received before the timer expires, a send-side Frame Relay end-to-end keepalive is recorded. If no reply is received before the timer expires, an error event is recorded. A number of the most recently recorded events are examined. If enough error events are accumulated, the keepalive status of the VC is changed from up to down, or if enough consecutive successful replies are received, the keepalive status of the VC is changed from down to up. The number of events that will be examined is called the *event window*.

The receive side is similar to the send side. The receive side waits for requests and sends out replies to those requests. If a request is received before the timer expires, a success event is recorded. If a request is not received, an error event is recorded. If enough error events occur in the event window, the PVC state will be changed from up to down. If enough consecutive success events occur, the state will be changed from down to up.

End-to-end keepalives can be configured in one of four modes: bidirectional, request, reply, or passive-reply.

- In bidirectional mode, both the send side and the receive side are enabled. The send side of the device sends out and waits for replies to keepalive requests from the receive side of the other PVC device. The receive side of the device waits for and replies to keepalive requests from the send side of the other PVC device.
- In request mode, only the send side is enabled, and the device sends out and waits for replies to its keepalive requests.
- In reply mode, only the receive side is enabled, and the device waits for and replies to keepalive requests.
- In passive-reply mode, the device only responds to keepalive requests, but does not set any timers or keep track of any events.

Because end-to-end keepalives allow traffic flow in both directions, they can be used to carry control and configuration information from end to end. Consistency of information between end hosts is critical in applications such as those relating to prioritized traffic and Voice over Frame Relay. Whereas SVCs can

convey such information within end-to-end signalling messages, PVCs will benefit from a bidirectional communication mechanism.

End-to-end keepalives are derived from the Frame Relay LMI protocol and work between peer Cisco communications devices. The key difference is that rather than running over the signalling channel, as is the case with LMI, end-to-end keepalives run over individual data channels.

Encapsulation of keepalive packets is proprietary; therefore, the feature is available only on Cisco devices running a software release that supports the Frame Relay End-to-End Keepalive feature.

You must configure both ends of a VC to send keepalives. If one end is configured as bidirectional, the other end must also be configured as bidirectional. If one end is configured as request, the other end must be configured as reply or passive-reply. If one end is configured as reply or passive-reply, the other end must be configured as request.

PPP over Frame Relay

Point-to-point protocol (PPP) over Frame Relay allows a router to establish end-to-end PPP sessions over Frame Relay. This is done over a PVC, which is the only circuit currently supported. The PPP session does not occur unless the associated Frame Relay PVC is in an "active" state. The Frame Relay PVC can coexist with other circuits using different Frame Relay encapsulation methods, such as RFC 1490 and the Cisco proprietary method, over the same Frame Relay link. There can be multiple PPP over Frame Relay circuits on one Frame Relay link.

One PPP connection resides on one virtual access interface. This is internally created from a virtual template interface, which contains all necessary PPP and network protocol information and is shared by multiple virtual access interfaces. The virtual access interface is coexistent with the creation of the Frame Relay circuit when the corresponding DLCI is configured. Hardware compression and fancy queueing algorithms, such as weighted fair queueing, custom queueing, and priority queueing, are not applied to virtual access interfaces.

PPP over Frame Relay is only supported on IP. IP datagrams are transported over the PPP link using RFC 1973 compliant Frame Relay framing. The frame format is shown in the figure below.

Figure 7 PPP over Frame Relay Frame Format

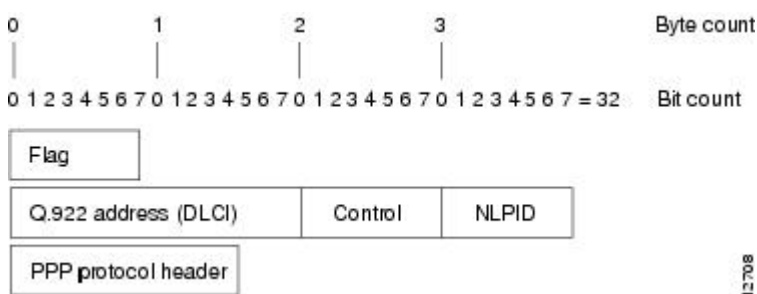

The table below lists the Frame Relay frame format components illustrated in the figure above.

Table 1 PPP Frame Relay Frame Format Descriptions

Field	Description
Flag	A single byte that indicates the beginning or end of a frame.

Field	Description
Address	A two-byte field that indicates the logical connection that maps to the physical channel; the DLCI.
Control	A single byte that calls for transmission of user data. PPP over Frame Relay uses a value of 0X03, which indicates that the frame is an unnumbered information (UI) frame.
NLPID	Network layer protocol ID--a single byte that uniquely identifies a PPP packet to Frame Relay.
PPP protocol	PPP packet type.

The figure below shows remote users running PPP to access their Frame Relay corporate networks.

Figure 8 PPP over Frame Relay Scenario

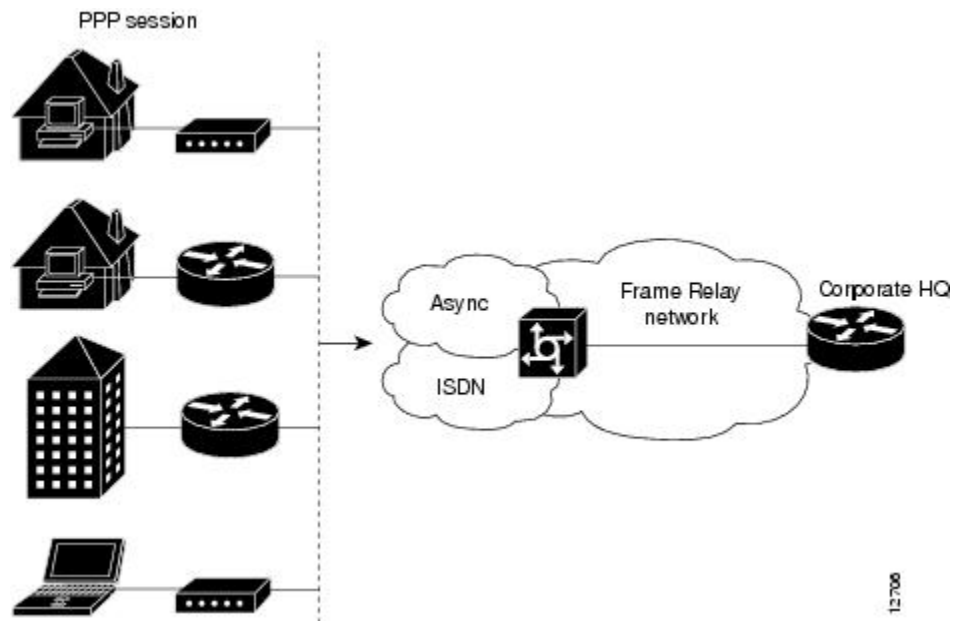

Before PPP over Frame Relay is configured, Frame Relay must be enabled on the router using the **encapsulation frame-relay** command. The only task required in order to implement PPP over Frame Relay is to configure the interface with the locally terminated PVC and the associated virtual template for PPP and IP, as described in the following section.

After configuring Frame Relay encapsulation on the Cisco router or access server, you must configure the physical interface with the PVC and apply a virtual template with PPP encapsulation to the DLCI.

Understanding Frame Relay Subinterfaces

Frame Relay subinterfaces provide a mechanism for supporting partially meshed Frame Relay networks. Most protocols assume transitivity on a logical network; that is, if station A can talk to station B, and

station B can talk to station C, then station A should be able to talk to station C directly. Transitivity is true on LANs, but not on Frame Relay networks unless A is directly connected to C.

Additionally, certain protocols such as AppleTalk and transparent bridging cannot be supported on partially meshed networks because they require *split horizon*. Split horizon is a routing technique in which a packet received on an interface cannot be sent from the same interface even if received and transmitted on different VCs.

Configuring Frame Relay subinterfaces ensures that a single physical interface is treated as multiple virtual interfaces. This treatment allows you to overcome split horizon rules. Packets received on one virtual interface can be forwarded to another virtual interface even if they are configured on the same physical interface.

Subinterfaces address the limitations of Frame Relay networks by providing a way to subdivide a partially meshed Frame Relay network into a number of smaller, fully meshed (or point-to-point) subnetworks. Each subnetwork is assigned its own network number and appears to the protocols as if it were reachable through a separate interface. (Note that point-to-point subinterfaces can be unnumbered for use with IP, reducing the addressing burden that might otherwise result.)

The figure below shows a five-node Frame Relay network that is partially meshed (network A). If the entire network is viewed as a single subnetwork (with a single network number assigned), most protocols assume that node A can transmit a packet directly to node E, when in fact it must be relayed through nodes C and D. This network can be made to work with certain protocols (for example, IP), but will not work at all with other protocols (for example, AppleTalk) because nodes C and D will not relay the packet out the same interface on which it was received. One way to make this network work fully is to create a fully

meshed network (network B), but doing so requires a large number of PVCs, which may not be economically feasible.

Figure 9 Using Subinterfaces to Provide Full Connectivity on a Partially Meshed Frame Relay Network

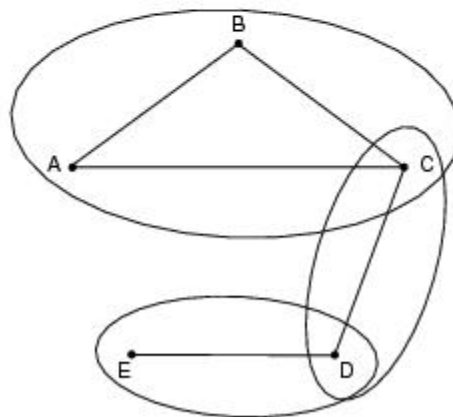
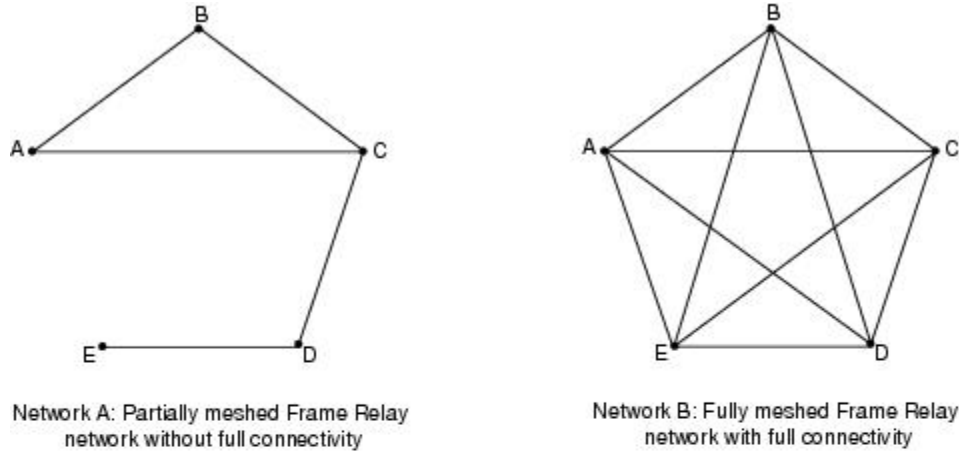

Network C: Partially meshed Frame Relay network with full connectivity (configuring subinterfaces)

FIGURE 9

Using subinterfaces, you can subdivide the Frame Relay network into three smaller subnetworks (network C) with separate network numbers. Nodes A, B, and C are connected to a fully meshed network, and nodes C and D, as well as nodes D and E, are connected via point-to-point networks. In this configuration, nodes C and D can access two subinterfaces and can therefore forward packets without violating split horizon rules. If transparent bridging is being used, each subinterface is viewed as a separate bridge port.

- [Subinterface Addressing, page 25](#)

Subinterface Addressing

- [Point-to-Point Subinterfaces, page 26](#)
- [Addressing on Multipoint Subinterfaces, page 26](#)

- [Backup Interface for a Subinterface, page 26](#)

Point-to-Point Subinterfaces

For point-to-point subinterfaces, the destination is presumed to be known and is identified or implied in the **frame-relay interface-dlci** command. This command is used to enable routing protocols on main interfaces that are configured to use Inverse ARP. This command is also helpful for assigning a specific class to a single PVC on a multipoint subinterface.

If you define a subinterface for point-to-point communication, you cannot reassign the same subinterface number to be used for multipoint communication without first rebooting the router or access server. Instead, you can simply avoid using that subinterface number and use a different subinterface number.

Addressing on Multipoint Subinterfaces

- [Accepting Inverse ARP for Dynamic Address Mapping on Multipoint Subinterfaces, page 51](#)
- [Configuring a Map Group with E.164 or X.121 Addresses, page 38](#)

Accepting Inverse ARP for Dynamic Address Mapping on Multipoint Subinterfaces

Dynamic address mapping uses Frame Relay Inverse ARP to request the next-hop protocol address for a specific connection, given a DLCI. Responses to Inverse ARP requests are entered in an address-to-DLCI mapping table on the router or access server; the table is then used to supply the next-hop protocol address or the DLCI for outgoing traffic.

Since the physical interface is now configured as multiple subinterfaces, you must provide information that distinguishes a subinterface from the physical interface and associates a specific subinterface with a specific DLCI.

Inverse ARP is enabled by default for all protocols it supports, but can be disabled for specific protocol-DLCI pairs. As a result, you can use dynamic mapping for some protocols and static mapping for other protocols on the same DLCI. You can explicitly disable Inverse ARP for a protocol-DLCI pair if you know the protocol is not supported on the other end of the connection. See the section "[Disabling or Reenabling Frame Relay Inverse ARP, page 53](#)" later in this chapter for more information.

Because Inverse ARP is enabled by default for all protocols that it supports, no additional command is required to configure dynamic address mapping on a subinterface.

Configuring Static Address Mapping on Multipoint Subinterfaces

A static map links a specified next-hop protocol address to a specified DLCI. Static mapping removes the need for Inverse ARP requests; when you supply a static map, Inverse ARP is automatically disabled for the specified protocol on the specified DLCI.

You must use static mapping if the router at the other end either does not support Inverse ARP at all or does not support Inverse ARP for a specific protocol that you want to use over Frame Relay.

Backup Interface for a Subinterface

Both point-to-point and multipoint Frame Relay subinterfaces can be configured with a backup interface. This approach allows individual PVCs to be backed up in case of failure rather than depending on the entire Frame Relay connection to fail before the backup takes over. You can configure a subinterface for backup on failure only, not for backup based on loading of the line.

If the main interface has a backup interface, it will have precedence over the subinterface's backup interface in the case of complete loss of connectivity with the Frame Relay network. As a result, a

subinterface backup is activated only if the main interface is up, or if the interface is down and does not have a backup interface defined. If a subinterface fails while its backup interface is in use, and the main interface goes down, the backup subinterface remains connected.

Disabling or Reenabling Frame Relay Inverse ARP

Frame Relay Inverse ARP is a method of building dynamic address mappings in Frame Relay networks running AppleTalk, Banyan VINES, DECnet, IP, Novell IPX, and XNS. Inverse ARP allows the router or access server to discover the protocol address of a device associated with the VC.

Inverse ARP creates dynamic address mappings, as contrasted with the **frame-relay map** command, which defines static mappings between a specific protocol address and a specific DLCI.

Inverse ARP is enabled by default but can be disabled explicitly for a given protocol and DLCI pair. Disable or reenable Inverse ARP under the following conditions:

- Disable Inverse ARP for a selected protocol and DLCI pair when you know that the protocol is not supported at the other end of the connection.
- Reenable Inverse ARP for a protocol and DLCI pair if conditions or equipment change and the protocol is then supported at the other end of the connection.



Note

If you change from a point-to-point subinterface to a multipoint subinterface, change the subinterface number. Frame Relay Inverse ARP will be on by default, and no further action is required.

You do not need to enable or disable Inverse ARP if you have a point-to-point interface, because there is only a single destination and discovery is not required.

Broadcast Queue for an Interface

Very large Frame Relay networks may have performance problems when many DLCIs terminate in a single router or access server that must replicate routing updates and service advertising updates on each DLCI. The updates can consume access-link bandwidth and cause significant latency variations in user traffic; the updates can also consume interface buffers and lead to higher packet rate loss for both user data and routing updates.

To avoid such problems, you can create a special broadcast queue for an interface. The broadcast queue is managed independently of the normal interface queue, has its own buffers, and has a configurable size and service rate.

A broadcast queue is given a maximum transmission rate (throughput) limit measured in both bytes per second and packets per second. The queue is serviced to ensure that no more than this maximum is provided. The broadcast queue has priority when transmitting at a rate below the configured maximum, and hence has a guaranteed minimum bandwidth allocation. The two transmission rate limits are intended to avoid flooding the interface with broadcasts. The actual transmission rate limit in any second is the first of the two rate limits that is reached.

Frame Relay Fragmentation

Cisco has developed three types of Frame Relay fragmentation, which are described in the following sections:

The following provides further information about Frame Relay fragmentation:

- [End-to-End FRF.12 Fragmentation](#), page 28

- [Setting the Fragment Size](#), page 28
- [Frame Relay Fragmentation Using FRF.11 Annex C](#), page 28
- [Cisco-Proprietary Fragmentation](#), page 29
- [Frame Relay Fragmentation and Hardware Compression Interoperability](#), page 29
- [Frame Relay Fragmentation Conditions and Restrictions](#), page 29

End-to-End FRF.12 Fragmentation

The purpose of end-to-end FRF.12 fragmentation is to support real-time and non-real-time data packets on lower-speed links without causing excessive delay to the real-time data. FRF.12 fragmentation is defined by the FRF.12 Implementation Agreement. This standard was developed to allow long data frames to be fragmented into smaller pieces (fragments) and interleaved with real-time frames. In this way, real-time and non-real-time data frames can be carried together on lower-speed links without causing excessive delay to the real-time traffic.

End-to-end FRF.12 fragmentation is recommended for use on permanent virtual circuits (PVCs) that share links with other PVCs that are transporting voice and on PVCs transporting Voice over IP (VoIP). Although VoIP packets should not be fragmented, they can be interleaved with fragmented packets.

FRF.12 is configured on a per-PVC basis using a Frame Relay map class. The map class can be applied to one or many PVCs. Frame Relay traffic shaping must be enabled on the interface in order for fragmentation to work.



Note

When Frame Relay fragmentation is configured, WFQ or LLQ is mandatory. If a map class is configured for Frame Relay fragmentation and the queueing type on that map class is not WFQ or LLQ, the configured queueing type is automatically overridden by WFQ with the default values. To configure LLQ for Frame Relay, refer to the *Cisco IOS Quality of Service Solutions Configuration Guide*, Release 12.2.

Setting the Fragment Size

Set the fragment size so that voice packets are not fragmented and do not experience a serialization delay greater than 20 ms.

To set the fragment size, the link speed must be taken into account. The fragment size should be larger than the voice packets, but small enough to minimize latency on the voice packets. Turn on fragmentation for low speed links (less than 768 kb/s).

Set the fragment size based on the lowest port speed between the routers. For example, if there is a hub and spoke Frame Relay topology where the hub has a T1 speed and the remote routers have 64 kb/s port speeds, the fragment size needs to be set for the 64 kb/s speed on both routers. Any other PVCs that share the same physical interface need to configure the fragmentation to the size used by the voice PVC.

If the lowest link speed in the path is 64 kb/s, the recommended fragment size (for 10 ms serialization delay) is 80 bytes. If the lowest link speed is 128 kb/s, the recommended fragment size is 160 bytes.

For more information, refer to the "[Fragmentation \(FRF.12\)](#)" section in the VoIP over Frame Relay with Quality of Service (Fragmentation, Traffic Shaping, LLQ / IP RTP Priority) document.

Frame Relay Fragmentation Using FRF.11 Annex C

When VoFR (FRF.11) and fragmentation are both configured on a PVC, the Frame Relay fragments are sent in the FRF.11 Annex C format. This fragmentation is used when FRF.11 voice traffic is sent on the PVC, and it uses the FRF.11 Annex C format for data.

With FRF.11, all data packets contain fragmentation headers, regardless of size. This form of fragmentation is not recommended for use with Voice over IP (VoIP).

See the chapter "Configuring Voice over Frame Relay" in the *Cisco IOS Voice, Video, and Fax Configuration Guide* for configuration tasks and examples for Frame Relay fragmentation using FRF.11 Annex C.

Cisco-Proprietary Fragmentation

Cisco-proprietary fragmentation is used on data packets on a PVC that is also used for voice traffic. When the **vofr cisco** command is configured on a DLCI and fragmentation is enabled on a map class, the Cisco 2600 series, 3600 series, and 7200 series routers can interoperate as tandem nodes (but cannot perform call termination) with Cisco MC3810 concentrators running Cisco IOS releases prior to 12.0(3)XG or 12.0(4)T.

To configure Cisco-proprietary voice encapsulation, use the **vofr cisco** command. You must then configure a map class to enable voice traffic on the PVCs.

See the chapter "Configuring Voice over Frame Relay" in the *Cisco IOS Voice, Video, and Fax Configuration Guide* for configuration tasks and examples for Cisco-proprietary fragmentation.

Frame Relay Fragmentation and Hardware Compression Interoperability

FRF.12, FRF.11 Annex C, and Cisco-proprietary fragmentation can be used with FRF.9 or data-stream hardware compression on interfaces and virtual circuits (VCs) using Cisco-proprietary or Internet Engineering Task Force (IETF) encapsulation types.

When payload compression and Frame Relay fragmentation are used at the same time, payload compression is always performed before fragmentation.

Frame Relay fragmentation can be used with the following hardware compression modules:

- Cisco 2600 AIM-COMPR2
- Cisco 3620 and 3640 NM-COMPR
- Cisco 3660 AIM-COMPR4
- Cisco 7200 SA-COMPR

Voice over Frame Relay and Voice over IP packets will not be payload-compressed when Frame Relay fragmentation is configured.



Note

On VCs using IETF encapsulation, FRF.9 hardware and software compression will work with Frame Relay fragmentation but will not work with header compression.

Frame Relay Fragmentation Conditions and Restrictions

When Frame Relay fragmentation is configured, the following conditions and restrictions apply:

- WFQ and LLQ at the PVC level are the only queueing strategies that can be used.
- Frame Relay traffic shaping (FRTS) must be configured to enable Frame Relay fragmentation (except on the Cisco 7500 series routers on which Versatile Interface Processor-Based Distributed FRF.11 and FRF.12 is enabled).

- VoFR frames are never fragmented, regardless of size.
- When end-to-end FRF.12 fragmentation is used, the VoIP packets will not include the FRF.12 header, provided the size of the VoIP packet is smaller than the fragment size configured. However, when FRF.11 Annex C or Cisco-proprietary fragmentations are used, VoIP packets will include the fragmentation header.
- If fragments arrive out of sequence, packets are dropped.

**Note**

Fragmentation is performed after frames are removed from the WFQ.

Payload Compression

- [Packet-by-Packet Payload Compression, page 30](#)
- [Standard-Based FRF.9 Compression, page 30](#)
- [Cisco-proprietary Data-Stream Compression, page 31](#)

Packet-by-Packet Payload Compression

You can configure payload compression on point-to-point or multipoint interfaces or subinterfaces. Payload compression uses the Predictor method to predict what the next character in the frame will be. Because the prediction is done packet by packet, the dictionary is not conserved across packet boundaries. Payload compression on each VC consumes approximately 40 kilobytes for dictionary memory.

Standard-Based FRF.9 Compression

Frame Relay compression can now occur on the VIP board, on the Compression Service Adapter (CSA), or on the main CPU of the router. FRF.9 is standard-based and therefore provides multivendor compatibility. FRF.9 compression uses relatively higher compression ratios, allowing more data to be compressed for faster transmission. FRF.9 compression provides the ability to maintain multiple decompression/compression histories on a per-DLCI basis.

The CSA hardware has been in use on the Cisco 7200 series and Cisco 7500 series platforms, but it has had no support for Frame Relay compression. The CSA can be used in the Cisco 7200 series or in the second-generation Versatile Interface Processor (VIP2) in all Cisco 7500 series routers. The specific VIP2 model required for the CSA is VIP2-40, which has 2 MB of SRAM and 32 MB of DRAM.

- [Selecting FRF.9 Compression Method, page 30](#)

Selecting FRF.9 Compression Method

The router enables compression in the following order:

- 1 If the router contains a compression service adapter, compression is performed in the CSA hardware (hardware compression).
- 2 If the CSA is not available, compression is performed in the software installed on the VIP2 card (distributed compression).
- 3 If the VIP2 card is not available, compression is performed in the main processor of the router (software compression).

Cisco-proprietary Data-Stream Compression

Data-stream compression is a proprietary hardware and software compression protocol that can be used on the same VC or interface and IP header compression. Data-stream compression is functionally equivalent to FRF.9 compression and must be used with Cisco-proprietary encapsulation. Frame Relay fragmentation can also be used with data-stream compression.

TCP/IP Header Compression

TCP/IP header compression, as described by RFC 1144, is designed to improve the efficiency of bandwidth utilization over low-speed serial links. A typical TCP/IP packet includes a 40-byte datagram header. Once a connection is established, the header information is redundant and need not be repeated in every packet that is sent. Reconstructing a smaller header that identifies the connection and indicates the fields that have changed and the amount of change reduces the number of bytes transmitted. The average compressed header is 10 bytes long.

For this algorithm to function, packets must arrive in order. If packets arrive out of order, the reconstruction will appear to create regular TCP/IP packets but the packets will not match the original. Because priority queueing changes the order in which packets are transmitted, enabling priority queueing on the interface is not recommended.

**Note**

If you configure an interface with Cisco-proprietary encapsulation and TCP/IP header compression, Frame Relay IP maps inherit the compression characteristics of the interface. However, if you configure the interface with IETF encapsulation, the interface cannot be configured for compression. Frame Relay maps will have to be configured individually to support TCP/IP header compression.

- [Specifying an Individual IP Map for TCP/IP Header Compression, page 31](#)
- [Specifying an Interface for TCP/IP Header Compression, page 31](#)

Specifying an Individual IP Map for TCP/IP Header Compression

**Note**

An interface configured to support TCP/IP header compression cannot also support priority queueing or custom queueing.

TCP/IP header compression requires Cisco-proprietary encapsulation. If you need to have IETF encapsulation on an interface as a whole, you can still configure a specific IP map to use Cisco-proprietary encapsulation and TCP header compression. In addition, even if you configure the interface to perform TCP/IP header compression, you can still configure a specific IP map not to compress TCP/IP headers.

You can specify whether TCP/IP header compression is active or passive. Active compression subjects every outgoing packet to TCP/IP header compression. Passive compression subjects an outgoing TCP/IP packet to header compression only if a packet had a compressed TCP/IP header when it was received.

Specifying an Interface for TCP/IP Header Compression

You can configure the interface with active or passive TCP/IP header compression. Active compression, the default, subjects all outgoing TCP/IP packets to header compression. Passive compression subjects an

outgoing packet to header compression only if the packet had a compressed TCP/IP header when it was received on that interface.

**Note**

If an interface configured with Cisco-proprietary encapsulation is later configured with IETF encapsulation, all TCP/IP header compression characteristics are lost. To apply TCP/IP header compression over an interface configured with IETF encapsulation, you must configure individual IP maps.

If you configure an interface with Cisco-proprietary encapsulation and TCP/IP header compression, Frame Relay IP maps inherit the compression characteristics of the interface. However, if you configure the interface with IETF encapsulation, the interface cannot be configured for compression. Frame Relay maps will have to be configured individually to support TCP/IP header compression.

Real-Time Header Compression with Frame Relay Encapsulation

Real-time Transport Protocol (RTP) is a protocol used for carrying packetized audio and video traffic over an IP network, providing end-to-end network transport functions intended for these real-time traffic applications and multicast or unicast network services. RTP is described in RFC 1889. RTP is not intended for data traffic, which uses TCP or UDP.

Discard Eligibility

Some Frame Relay packets can be set with low priority or low time sensitivity. These will be the first to be dropped when a Frame Relay switch is congested. The mechanism that allows a Frame Relay switch to identify such packets is the discard eligibility (DE) bit.

Discard eligibility requires the Frame Relay network to be able to interpret the DE bit. Some networks take no action when the DE bit is set, and others use the DE bit to determine which packets to discard. The best interpretation is to use the DE bit to determine which packets should be dropped first and also which packets have lower time sensitivity.

You can create DE lists that identify the characteristics of packets to be eligible for discarding, and you can also specify DE groups to identify the DLCI that is affected.

You can create DE lists based on the protocol or the interface, and on characteristics such as fragmentation of the packet, a specific TCP or User Datagram Protocol (UDP) port, an access list number, or a packet size.

DLCI Priority Levels

DLCI priority levels allow you to separate different types of traffic and provides a traffic management tool for congestion problems caused by following situations:

- Mixing batch and interactive traffic over the same DLCI
- Queueing traffic from sites with high-speed access at destination sites with lower-speed access

Before you configure the DLCI priority levels, you must:

- Define a global priority list.
- Enable Frame Relay encapsulation.
- Define dynamic or static address mapping.
- Make sure that you define each of the DLCIs to which you intend to apply levels. You can associate priority-level DLCIs with subinterfaces.

- Configure the LMI.

**Note**

DLCI priority levels provide a way to define multiple parallel DLCIs for different types of traffic. DLCI priority levels do not assign priority queues within the router or access server. In fact, they are independent of the device's priority queues. However, if you enable queueing and use the same DLCIs for queueing, then high-priority DLCIs can be put into high-priority queues.

How to Configure Frame Relay

- [Enabling Frame Relay Encapsulation on an Interface](#), page 33
- [Configuring Static Address Mapping](#), page 33
- [Explicitly Configuring the LMI](#), page 34
- [Enabling Frame Relay SVC Service](#), page 35
- [Configuring Frame Relay Traffic Shaping](#), page 40
- [Configuring Frame Relay Switching](#), page 43
- [Customizing Frame Relay for Your Network](#), page 48

Enabling Frame Relay Encapsulation on an Interface

**Note**

Frame Relay encapsulation is a prerequisite for any Frame Relay commands on an interface.

To enable Frame Relay encapsulation on the interface level, use the following commands beginning in global configuration mode:

SUMMARY STEPS

1. Router(config)# **interface** *typenumber*
2. Router(config-if)# **encapsulation frame-relay**[ietf]

DETAILED STEPS

	Command or Action	Purpose
Step 1	Router(config)# interface <i>typenumber</i>	Specifies the interface, and enters interface configuration mode.
Step 2	Router(config-if)# encapsulation frame-relay [ietf]	Enables and specifies the Frame Relay encapsulation method.

Configuring Static Address Mapping

To establish static mapping according to your network needs, use one of the following commands in interface configuration mode:

Command	Purpose
Router(config-if)# frame-relay map <i>protocol protocol-address dci</i> [broadcast] [ietf] [cisco]	Maps between a next-hop protocol address and DLCI destination address. The supported protocols and the corresponding keywords to enable them are as follows: <ul style="list-style-type: none"> • IP--ip • DECnet--decnet • AppleTalk--appletalk • XNS--xns • Novell IPX--ipx • VINES--vines • ISO CLNS--clns
Router(config-if)# frame-relay map clns <i>dci</i> [broadcast]	Defines a DLCI used to send ISO CLNS frames.
Router(config-if)# frame-relay map bridge <i>dci</i> [broadcast] [ietf]	Defines a DLCI destination bridge.

Explicitly Configuring the LMI

- [Setting the LMI Type, page 34](#)
- [Setting the LMI Keepalive Interval, page 35](#)
- [Setting the LMI Polling and Timer Intervals, page 35](#)

Setting the LMI Type

If the router or access server is attached to a public data network (PDN), the LMI type must match the type used on the public network. Otherwise, the LMI type can be set to suit the needs of your private Frame Relay network. You can set one of the following three types of LMIs on Cisco devices: ANSI T1.617 Annex D, Cisco, and ITU-T Q.933 Annex A. To do so, use the following commands beginning in interface configuration mode:

SUMMARY STEPS

1. Router(config-if)# **frame-relay lmi-type** {ansi | cisco | q933a}
2. Router# **copy nvram:startup-config** *destination*

DETAILED STEPS

	Command or Action	Purpose
Step 1	Router(config-if)# frame-relay lmi-type {ansi cisco q933a}	Sets the LMI type.
Step 2	Router# copy nvram:startup-config <i>destination</i>	Writes the LMI type to NVRAM.

Setting the LMI Keepalive Interval

A keepalive interval must be set to configure the LMI. By default, this interval is 10 seconds and, according to the LMI protocol, must be less than the corresponding interval on the switch. To set the keepalive interval, use the following command in interface configuration mode:

Command	Purpose
<code>Router(config-if)# keepalive <i>number</i></code>	Sets the LMI keepalive interval.

Setting the LMI Polling and Timer Intervals

You can set various optional counters, intervals, and thresholds to fine-tune the operation of your LMI DTE and DCE devices. Set these attributes by using one or more of the following commands in interface configuration mode:

Command	Purpose
<code>frame-relay lmi-n392dce <i>threshold</i></code>	Sets the DCE and Network-to-Network Interface (NNI) error threshold.
<code>frame-relay lmi-n393dce <i>events</i></code>	Sets the DCE and NNI monitored events count.
<code>frame-relay lmi-t392dce <i>seconds</i></code>	Sets the polling verification timer on a DCE or NNI interface.
<code>frame-relay lmi-n391dte <i>keep-exchanges</i></code>	Sets a full status polling interval on a DTE or NNI interface.
<code>frame-relay lmi-n392dte <i>threshold</i></code>	Sets the DTE or NNI error threshold.
<code>frame-relay lmi-n393dte <i>events</i></code>	Sets the DTE and NNI monitored events count.

Enabling Frame Relay SVC Service

- [Configuring SVCs on a Physical Interface, page 35](#)
- [Configuring SVCs on a Subinterface, page 36](#)
- [Configuring a Map Class, page 37](#)
- [Configuring a Map Group with E.164 or X.121 Addresses, page 38](#)
- [Associating the Map Class with Static Protocol Address Maps, page 39](#)
- [Configuring LAPF Parameters, page 39](#)

Configuring SVCs on a Physical Interface

To enable SVC operation on a Frame Relay interface, use the following commands beginning in global configuration mode:

SUMMARY STEPS

1. Router(config)# **interface** *type number*
2. Router(config-if)# **ip address** *ip-address mask*
3. Router(config-if)# **encapsulation frame-relay**
4. Router(config-if)# **map-group** *group-name*
5. Router(config-if)# **frame-relay svc**

DETAILED STEPS

	Command or Action	Purpose
Step 1	Router(config)# interface <i>type number</i>	Specifies the physical interface.
Step 2	Router(config-if)# ip address <i>ip-address mask</i>	Specifies the interface IP address, if needed.
Step 3	Router(config-if)# encapsulation frame-relay	Enables Frame Relay encapsulation on the interface.
Step 4	Router(config-if)# map-group <i>group-name</i>	Assigns a map group to the interface. Map group details are specified with the map-list command.
Step 5	Router(config-if)# frame-relay svc	Enables Frame Relay SVC support on the interface.

Configuring SVCs on a Subinterface**Note**

This task offers additional flexibility for SVC configuration and operation.

To configure Frame Relay SVCs on a subinterface, complete all the commands in the preceding section, except assigning the map group. After the physical interface is configured, use the following commands beginning in global configuration mode:

SUMMARY STEPS

1. Router(config)# **interface** *type number . subinterface-number* { **multipoint** | **point-to-point** }
2. Router(config-subif)# **ip address** *ip-address mask*
3. Router(config-subif)# **map-group** *group-name*

DETAILED STEPS

	Command or Action	Purpose
Step 1	Router(config)# interface <i>type number . subinterface-number</i> { multipoint point-to-point }	Specifies a subinterface configured for SVC operation.
Step 2	Router(config-subif)# ip address <i>ip-address mask</i>	Specifies the subinterface IP address, if needed.
Step 3	Router(config-subif)# map-group <i>group-name</i>	Assigns a map group to the subinterface.

Configuring a Map Class

Perform the following tasks to configure a map class:

- Specify the map class name. (Required)
- Specify a custom queue list for the map class. (Optional)
- Specify a priority queue list for the map class. (Optional)
- Enable BECN feedback to throttle the output rate on the SVC for the map class. (Optional)
- Set nondefault QoS values for the map class (no need to set the QoS values; default values are provided). (Optional)



Note

You can define multiple map classes. A map class is associated with a static map, not with the interface or subinterface. Because of the flexibility this association allows, you can define different map classes for different destinations.

To configure a map class, use the following commands beginning in global configuration mode:

SUMMARY STEPS

1. Router(config)# **map-class frame-relay** *map-class-name*
2. Router(config-map-class)# **frame-relay custom-queue-list** *list-number*
3. Router(config-map-class)# **frame-relay priority-group** *list-number*
4. Router(config-map-class)# **frame-relay adaptive-shaping**[**becn** | **foresight**]¹
5. Router(config-map-class)# **frame-relay cir in** *bps*
6. Router(config-map-class)# **frame-relay cir out** *bps*
7. Router(config-map-class)# **frame-relay mincir in** *bps*²
8. Router(config-map-class)# **frame-relay mincir out** *bps* [Configuring a Map Class, page 37](#)
9. Router(config-map-class)# **frame-relay bc in** *bits* [Configuring a Map Class, page 37](#)
10. Router(config-map-class)# **frame-relay bc out** *bits* [Configuring a Map Class, page 37](#)
11. Router(config-map-class)# **frame-relay be in** *bits* [Configuring a Map Class, page 37](#)
12. Router(config-map-class)# **frame-relay be out** *bits* [Configuring a Map Class, page 37](#)
13. Router(config-map-class)# **frame-relay idle-timer** *seconds* [Configuring a Map Class, page 37](#)

DETAILED STEPS

	Command or Action	Purpose
Step 1	Router(config)# map-class frame-relay <i>map-class-name</i>	Specifies Frame Relay map class name and enters map class configuration mode.
Step 2	Router(config-map-class)# frame-relay custom-queue-list <i>list-number</i>	Specifies a custom queue list to be used for the map class.

¹ This command replaces the frame-relay becn-response-enable command, which will be removed in a future Cisco IOS release. If you use the frame-relay becn-response-enable command in scripts, you should replace it with the frame-relay adaptive-shaping becn command.

² The in and out keywords are optional. Configuring the command without the in and out keywords will apply that value to both the incoming and the outgoing traffic values for the SVC setup. For example, frame-relay cir 56000 applies 56000 to both incoming and outgoing traffic values for setting up the SVC.

	Command or Action	Purpose
Step 3	Router(config-map-class)# frame-relay priority-group <i>list-number</i>	Assigns a priority queue to VCs associated with the map class.
Step 4	Router(config-map-class)# frame-relay adaptive-shaping [beccn foresight] ¹	Enables the type of BECN feedback to throttle the frame-transmission rate.
Step 5	Router(config-map-class)# frame-relay cir in <i>bps</i>	Specifies the inbound committed information rate (CIR), in bits per second.
Step 6	Router(config-map-class)# frame-relay cir out <i>bps</i>	Specifies the outbound CIR, in bits per second.
Step 7	Router(config-map-class)# frame-relay mincir in <i>bps</i> ²	Sets the minimum acceptable incoming CIR, in bits per second.
Step 8	Router(config-map-class)# frame-relay mincir out <i>bps</i> Configuring a Map Class, page 37	Sets the minimum acceptable outgoing CIR, in bits per second.
Step 9	Router(config-map-class)# frame-relay bc in <i>bits</i> Configuring a Map Class, page 37	Sets the incoming committed burst size (Bc), in bits.
Step 10	Router(config-map-class)# frame-relay bc out <i>bits</i> Configuring a Map Class, page 37	Sets the outgoing Bc, in bits.
Step 11	Router(config-map-class)# frame-relay be in <i>bits</i> Configuring a Map Class, page 37	Sets the incoming excess burst size (Be), in bits.
Step 12	Router(config-map-class)# frame-relay be out <i>bits</i> Configuring a Map Class, page 37	Sets the outgoing Be, in bits.
Step 13	Router(config-map-class)# frame-relay idle-timer <i>seconds</i> Configuring a Map Class, page 37	Sets the idle timeout interval, in seconds.

Configuring a Map Group with E.164 or X.121 Addresses

After you have defined a map group for an interface, you can associate the map group with a specific source and destination address to be used. You can specify E.164 addresses or X.121 addresses for the source and destination. To specify the map group to be associated with a specific interface, use the following command in global configuration mode:

Command	Purpose
Router(config)# map-list <i>map-group-name</i> source-addr { e164 x121 } <i>source-address</i> dest-addr { e164 x121 } <i>destination-address</i>	Specifies the map group associated with specific source and destination addresses for the SVC.

¹ This command replaces the frame-relay becn-response-enable command, which will be removed in a future Cisco IOS release. If you use the frame-relay becn-response-enable command in scripts, you should replace it with the frame-relay adaptive-shaping becn command.

² The in and out keywords are optional. Configuring the command without the in and out keywords will apply that value to both the incoming and the outgoing traffic values for the SVC setup. For example, frame-relay cir 56000 applies 56000 to both incoming and outgoing traffic values for setting up the SVC.

Associating the Map Class with Static Protocol Address Maps

To define the protocol addresses under a **map-list** command and associate each protocol address with a specified map class, use the **class** command. Use this command for each protocol address to be associated with a map class. To associate a map class with a protocol address, use the following command in map list configuration mode:

Command	Purpose
<pre>Router(config-map-list)# protocol protocol- address class <i>class-name</i> [ietf] [broadcast [trigger]]</pre>	<p>Specifies a destination protocol address and a Frame Relay map class name from which to derive QoS information.</p> <ul style="list-style-type: none"> The ietf keyword specifies RFC 1490 encapsulation The broadcast keyword specifies that broadcasts must be carried. The trigger keyword, which can be configured only if broadcast is also configured, enables a broadcast packet to trigger an SVC. If an SVC already exists that uses this map class, the SVC will carry the broadcast.

Configuring LAPF Parameters



Note

The LAPF tasks are not required and not recommended unless you understand thoroughly the impacts on your network.

By default, the Frame Reject frame is sent at the LAPF Frame Reject procedure.

Frame Relay Link Access Procedure for Frame Relay (LAPF) commands are used to tune Layer 2 system parameters to work well with the Frame Relay switch. Normally, you do not need to change the default settings. However, if the Frame Relay network indicates that it does not support the Frame Reject frame (FRMR) at the LAPF Frame Reject procedure, use the following command in interface configuration mode:

Command	Purpose
<pre>Router(config-if)# no frame-relay lapf frmr</pre>	<p>Selects not to send FRMR frames at the LAPF Frame Reject procedure.</p>

- [Changing Layer 2 Parameters for Your Network, page 39](#)

Changing Layer 2 Parameters for Your Network

**Note**

Manipulation of Layer 2 parameters is not recommended if you do not know well the resulting functional change. For more information, refer to the ITU-T Q.922 specification for LAPF.

If you must change Layer 2 parameters for your network environment and you understand the resulting functional change, use the following commands as needed:

Command	Purpose
Router(config-if)# frame-relay lapf k <i>number</i>	Sets the LAPF window size k.
Router(config-if)# frame-relay lapf n200 <i>retries</i>	Sets the LAPF maximum retransmission count N200.
Router(config-if)# frame-relay lapf n201 <i>bytes</i>	Sets maximum length of the Information field of the LAPF I frame N201, in bytes.
Router(config-if)# frame-relay lapf t200 <i>tenths-of-a-second</i>	Sets the LAPF retransmission timer value T200, in tenths of a second.
Router(config-if)# frame-relay lapf t203 <i>seconds</i>	Sets the LAPF link idle timer value T203 of DLCI 0, in seconds.

Configuring Frame Relay Traffic Shaping

- [Enabling Frame Relay Traffic Shaping on the Interface](#), page 40
- [Configuring Enhanced Local Management Interface](#), page 41
- [Specifying a Traffic-Shaping Map Class for the Interface](#), page 42
- [Defining a Map Class with Queueing and Traffic-Shaping Parameters](#), page 43

Enabling Frame Relay Traffic Shaping on the Interface

To configure a map class with traffic-shaping and per-VC queueing parameters, see the sections [GUID-EEC09F78-5EAE-4C67-9A84-1D9E9B7E638B](#) and [Defining a Map Class with Queueing and Traffic-Shaping Parameters](#), page 43.

To enable Frame Relay traffic shaping on the specified interface, use the following command in interface configuration mode:

Command	Purpose
Router(config-if)# frame-relay traffic-shaping	<p>Enables Frame Relay traffic shaping and per-VC queuing.</p> <p>Note The default committed information rate (CIR) of 56K will apply in the following situations: When traffic shaping is enabled (by using the frame-relay traffic-shaping command), but a map class is not assigned to the VC and when traffic shaping is enabled (by using the frame-relay traffic-shaping command) and a map class is assigned to the VC, but traffic-shaping parameters have not been defined in the map class.</p>

Configuring Enhanced Local Management Interface

- [Enabling ELMI, page 41](#)
- [Disabling Automatic IP Address Selection, page 41](#)
- [Configuring the IP Address to Be Used for ELMI Address Registration, page 42](#)
- [Enabling ELMI Address Registration on an Interface, page 42](#)
- [Verifying ELMI Address Registration, page 42](#)

Enabling ELMI

To enable ELMI, use the following commands beginning in interface configuration mode:

SUMMARY STEPS

1. Router(config)# **interface** *type number*
2. Router(config-if)# **encapsulation frame-relay**[cisco | ietf]
3. Router(config-if)# **frame-relay QoS-autosense**

DETAILED STEPS

	Command or Action	Purpose
Step 1	Router(config)# interface <i>type number</i>	Specifies the physical interface.
Step 2	Router(config-if)# encapsulation frame-relay [cisco ietf]	Enables Frame Relay encapsulation on the interface.
Step 3	Router(config-if)# frame-relay QoS-autosense	Enables ELMI.

Disabling Automatic IP Address Selection

Automatic IP address selection is enabled by default when ELMI is enabled. To disable the automatic selection of the IP address to be used for ELMI address registration, use the following global configuration command:

Command	Purpose
Router(config)# no frame-relay address registration auto-address	<p>Disables the automatic selection of the IP address to be used for ELMI address registration.</p> <p>Note When automatic IP address selection is disabled and an IP address has not been configured using the frame-relay address registration ip global configuration command, the IP address for ELMI address registration will be set to 0.0.0.0.</p>

Configuring the IP Address to Be Used for ELMI Address Registration

To configure the IP address for ELMI address registration, use the following global configuration command:

Command	Purpose
Router(config)# frame-relay address registration ip address	<p>Configures the IP address to be used for ELMI address registration.</p> <p>Note Automatic IP address selection is disabled when you configure the management IP address using the frame-relay address registration ip global configuration command.</p>

Enabling ELMI Address Registration on an Interface

To enable ELMI address registration on an interface, use the following interface configuration command:

Command	Purpose
Router(config-if)# frame-relay address-reg enable	<p>Enables ELMI address registration on an interface.</p> <p>To disable ELMI address registration on an interface, use the no form of the command.</p>

Verifying ELMI Address Registration

To verify that ELMI address registration is configured correctly, use the following privileged EXEC configuration command:

Command	Purpose
Router# show frame-relay qos-autosense [interface interface]	Displays the QoS values and ELMI address registration information sensed from the switch.

Specifying a Traffic-Shaping Map Class for the Interface

To specify a map class for the specified interface, use the following command beginning in interface configuration mode:

SUMMARY STEPS

1. Router(config-if)# **frame-relay class** *map-class-name*

DETAILED STEPS

	Command or Action	Purpose
Step 1	Router(config-if)# frame-relay class <i>map-class-name</i>	Specifies a Frame Relay map class for the interface.

Defining a Map Class with Queueing and Traffic-Shaping Parameters

To define a map class, use the following commands beginning in global configuration mode:

SUMMARY STEPS

1. Router(config)# **map-class frame-relay** *map-class-name*
2. Router(config-map-class)# **frame-relay traffic-rate** *average* [*peak*]
3. Router(config-map-class)# **frame-relay custom-queue-list** *list-number*
4. Router(config-map-class)# **frame-relay priority-group** *list-number*
5. Router(config-map-class)# **frame-relay adaptive-shaping**{ **becn** | **foresight** }

DETAILED STEPS

	Command or Action	Purpose
Step 1	Router(config)# map-class frame-relay <i>map-class-name</i>	Specifies a map class to define.
Step 2	Router(config-map-class)# frame-relay traffic-rate <i>average</i> [<i>peak</i>]	Defines the traffic rate for the map class.
Step 3	Router(config-map-class)# frame-relay custom-queue-list <i>list-number</i>	Specifies a custom queue list.
Step 4	Router(config-map-class)# frame-relay priority-group <i>list-number</i>	Specifies a priority queue list.
Step 5	Router(config-map-class)# frame-relay adaptive-shaping { becn foresight }	<p>Selects BECN or ForeSight as congestion backward-notification mechanism to which traffic shaping adapts.</p> <p>Note This command replaces the frame-relay becn-response-enable command, which will be removed in a future Cisco IOS release. If you use the frame-relay becn-response-enable command in scripts, you should replace it with the frame-relay adaptive-shaping software command.</p>

Configuring Frame Relay Switching

- [Enabling Frame Relay Switching, page 44](#)

- [Configuring a Frame Relay DTE Device or DCE Switch or NNI Support, page 44](#)
- [Creating Switched PVC over ISDN, page 44](#)
- [Creating a Switched PVC with Static Route, page 44](#)
- [Identifying a PVC As Switched, page 45](#)
- [Configuring Traffic Policing on UNI DCE Devices, page 45](#)
- [Configuring Congestion Management on Switched PVCs, page 46](#)
- [Configuring FRF.12 Fragmentation on Switched PVCs, page 47](#)
- [Verifying Frame Relay Switching, page 47](#)
- [Troubleshooting Frame Relay Switching, page 47](#)

Enabling Frame Relay Switching

You must enable packet switching before you can configure it on a Frame Relay DTE or DCE, or with Network-to-Network Interface (NNI) support. Do so by using the following command in global configuration mode before configuring the switch type:

Command	Purpose
<code>Router(config)# frame-relay switching</code>	Enables Frame Relay switching.

Configuring a Frame Relay DTE Device or DCE Switch or NNI Support

You can configure an interface as a DTE device or a DCE switch, or as a switch connected to a switch to support NNI connections. (DTE is the default.) To do so, use the following command in interface configuration mode:

Command	Purpose
<code>Router(config-if)# frame-relay intf-type [dce dte nni]</code>	Configures a Frame Relay DTE device or DCE switch.

Creating Switched PVC over ISDN

To create a switched PVC over ISDN, or to create a switched PVC on which traffic shaping, traffic policing, and congestion management can be configured, use the following command in global configuration mode:

Command	Purpose
<code>Router(config)# connect <i>connection-name</i> <i>interface dlc</i> <i>interface dlc</i></code>	Defines connections between Frame Relay PVCs.

Creating a Switched PVC with Static Route

**Note**

Static routes cannot be configured over tunnel interfaces on the Cisco 800 series, 1600 series, and 1700 series platforms. Static routes can only be configured over tunnel interfaces on platforms that have the Enterprise feature set.

To create a switched PVC with a static route, use the following command in interface configuration mode:

Command	Purpose
<code>Router(config-if)# frame-relay route in-dlci interface out-interface-type out-interface-number out-dlci</code>	Specifies a static route for PVC switching.

Identifying a PVC As Switched

Before you can associate a map class with a switched PVC, you must identify the PVC as being switched. To identify a PVC as switched, use the following command in interface configuration mode:

Command	Purpose
<code>Router(config-if)# frame-relay interface-dlci dlci switched</code>	Identifies a PVC as switched.

Configuring Traffic Policing on UNI DCE Devices

- [Enabling Frame Relay Policing, page 45](#)
- [Configuring Frame Relay Policing Parameters, page 45](#)

Enabling Frame Relay Policing

To enable Frame Relay policing on a interface, use the following command in interface configuration mode:

Command	Purpose
<code>Router(config-if)# frame-relay policing</code>	Enables Frame Relay policing on all switched PVCs on the interface.

Configuring Frame Relay Policing Parameters

To configure policing parameters in a Frame Relay map class, use one or more of the following commands in map-class configuration mode:

Command	Purpose
<code>Router(config-map-class)# frame-relay cir {in out} bps</code>	Sets the CIR for a Frame Relay PVC, in bits per second.

Command	Purpose
Router(config-map-class)# frame-relay bc {in out} <i>bits</i>	Sets the committed burst size for a Frame Relay PVC, in bits.
Router(config-map-class)# frame-relay be {in out} <i>bits</i>	Sets the excess burst size for a Frame Relay PVC, in bits.
Router(config-map-class)# frame-relay tc <i>milliseconds</i>	Sets the measurement interval for policing incoming traffic on a PVC when the CIR is zero, in milliseconds.

Configuring Congestion Management on Switched PVCs

- [Configuring Frame Relay Congestion Management on the Interface, page 46](#)
- [Configuring Frame Relay Congestion Management on Traffic-Shaping Queues, page 46](#)

Configuring Frame Relay Congestion Management on the Interface

To configure Frame Relay congestion management on all switched PVCs on an interface, use the following commands beginning in interface configuration mode:

SUMMARY STEPS

1. Router(config-if)# **frame-relay congestion management**
2. Router(config-fr-congest)# **threshold de** *percentage*
3. Router(config-fr-congest)# **threshold ecn** {bc | be} *percentage*

DETAILED STEPS

	Command or Action	Purpose
Step 1	Router(config-if)# frame-relay congestion management	Enables Frame Relay congestion management on all switched PVCs on an interface and enters Frame Relay congestion management configuration mode.
Step 2	Router(config-fr-congest)# threshold de <i>percentage</i>	Configures the threshold at which DE-marked packets will be discarded from switched PVCs on the output interface.
Step 3	Router(config-fr-congest)# threshold ecn {bc be} <i>percentage</i>	Configures the threshold at which ECN bits will be set on packets in switched PVCs on the output interface.

Configuring Frame Relay Congestion Management on Traffic-Shaping Queues

To configure Frame Relay congestion management on the traffic-shaping queues of switched PVCs, use one or more of the following commands in map-class configuration mode:

Command	Purpose
Router(config-map-class)# frame-relay congestion threshold de <i>percentage</i>	Configures the threshold at which DE-marked packets will be discarded from the traffic-shaping queue of a switched PVC.
Router(config-map-class)# frame-relay congestion threshold ecn <i>percentage</i>	Configures the threshold at which ECN bits will be set on packets in the traffic-shaping queue of a switched PVC.
Router(config-map-class)# frame-relay holdq <i>queue-size</i>	Configures the maximum size of a traffic-shaping queue on a switched PVC.

Configuring FRF.12 Fragmentation on Switched PVCs

To configure FRF.12 on switched PVCs, use the following map-class configuration command. The map class can be associated with one or more switched PVCs.

Command	Purpose
Router(config-map-class)# frame-relay fragment <i>fragment_size</i> switched	Enables FRF.12 fragmentation on switched Frame Relay PVCs for a Frame Relay map class.

Verifying Frame Relay Switching

To verify the correct configuration of Frame Relay switching, use one or more of the following commands:

Command	Purpose
Router# show frame-relay fragment [interface <i>interface</i>] [<i>dci</i>]	Displays statistics about Frame Relay fragmentation.
Router# show frame-relay pvc [interface <i>interface</i>] [<i>dci</i>]	Displays statistics about Frame Relay PVCs including detailed reasons for packet drops on switched PVCs and complete status information for switched NNI PVCs.
Router# show interfaces [<i>type number</i>]	Displays information about the configuration and queue at the interface.

Troubleshooting Frame Relay Switching

To diagnose problems in switched Frame Relay networks, use the following EXEC commands:

Command	Purpose
Router# debug frame-relay switching [interface <i>interface</i>] [<i>dldci</i>] [interval <i>seconds</i>]	Displays debug messages for switched Frame Relay PVCs. The interval keyword and <i>seconds</i> argument sets the interval at which the debug messages will be displayed.
Router# show frame-relay pvc [interface <i>interface</i>] [<i>dldci</i>]	Displays statistics about Frame Relay PVCs, including detailed reasons for packet drops on switched PVCs and complete status information for switched NNI PVCs.

Customizing Frame Relay for Your Network

- [Configuring Frame Relay End-to-End Keepalives, page 48](#)
- [Enabling PPP over Frame Relay, page 50](#)
- [Configuring Frame Relay Subinterfaces, page 50](#)
- [Disabling or Reenabling Frame Relay Inverse ARP, page 53](#)
- [Creating a Broadcast Queue for an Interface, page 54](#)
- [Configuring Frame Relay Fragmentation, page 54](#)
- [Configuring Payload Compression, page 55](#)
- [Configuring TCP/IP Header Compression, page 59](#)
- [Configuring Discard Eligibility, page 60](#)
- [Configuring DLCI Priority Levels, page 60](#)
- [Monitoring and Maintaining the Frame Relay Connections, page 61](#)

Configuring Frame Relay End-to-End Keepalives

- [Configuring End-to-End Keepalives, page 48](#)
- [Modifying the Default Parameters, page 49](#)
- [Verifying Frame Relay End-to-End Keepalives, page 49](#)

Configuring End-to-End Keepalives

To configure Frame Relay end-to-end keepalives, use the following commands beginning in global configuration mode:

SUMMARY STEPS

1. Router(config)# **map-class frame-relay** *map-class-name*
2. Router(config-map-class)# **frame-relay end-to-end keepalive mode** {**bidirectional** | **request** | **reply** | **passive-reply**}

DETAILED STEPS

	Command or Action	Purpose
Step 1	Router(config)# map-class frame-relay <i>map-class-name</i>	Specifies a map class for the VC.
Step 2	Router(config-map-class)# frame-relay end-to-end keepalive mode { bidirectional request reply passive-reply }	Specifies Frame Relay end-to-end keepalive mode. <ul style="list-style-type: none"> • bidirectional --The device sends keepalive requests to the other end of the VC and responds to keepalive requests from the other end of the VC. • request --The device sends keepalive requests to the other end of the VC. • reply --The device responds to keepalive requests from the other end of the VC. • passive-reply --The device responds to keepalive requests from the other end of the VC, but will not track errors or successes.

Modifying the Default Parameters

You can modify the end-to-end keepalives default parameter values by using any of the following map-class configuration commands:

Command	Purpose
Router(config-map-class)# frame-relay end-to-end keepalive error-threshold { send receive } <i>count</i>	Modifies the number of errors needed to change the keepalive state from up to down.
Router(config-map-class)# frame-relay end-to-end keepalive event-window { send receive } <i>count</i>	Modifies the number of recent events to be checked for errors.
Router(config-map-class)# frame-relay end-to-end keepalive success-events { send receive } <i>count</i>	Modifies the number of consecutive success events required to change the keepalive state from down to up.
Router(config-map-class)# frame-relay end-to-end keepalive timer { send receive } <i>interval</i>	Modifies the timer interval.

Verifying Frame Relay End-to-End Keepalives

To monitor the status of Frame Relay end-to-end keepalives, use the following command in EXEC configuration mode:

Command	Purpose
Router# show frame-relay end-to-end keepalive <i>interface</i>	Shows the status of Frame Relay end-to-end keepalives.

Enabling PPP over Frame Relay

To configure the physical interface that will carry the PPP session and link it to the appropriate virtual template interface, perform the following task in interface configuration mode:

Command	Purpose
Router(config-if)# frame-relay interface-dlci <i>dlci</i> [ppp <i>virtual-template-name</i>]	Defines the PVC and maps it to the virtual template.

For an example of configuring PPP over Frame Relay, see the section [Example PPPoverFrameRelay](#), page 79 or [Example PPP over Frame Relay DCE](#), page 79 later in this chapter.

Configuring Frame Relay Subinterfaces

- [Configuring Subinterfaces](#), page 50
- [Defining Subinterface Addressing on Point-to-Point Subinterfaces](#), page 50
- [Accepting Inverse ARP for Dynamic Address Mapping on Multipoint Subinterfaces](#), page 51
- [Configuring Static Address Mapping on Multipoint Subinterfaces](#), page 51
- [Configuring Transparent Bridging for Point-to-Point Subinterfaces](#), page 52
- [Configuring Transparent Bridging for Point-to-Multipoint Interfaces](#), page 52
- [Configuring a Backup Interface for a Subinterface](#), page 53

Configuring Subinterfaces

Subinterfaces can be configured for multipoint or point-to-point communication. (There is no default.) To configure subinterfaces on a Frame Relay network, use the following commands beginning in global configuration mode:

SUMMARY STEPS

1. Router(config)# **interface type number . subinterface-number { multipoint | point-to-point }**
2. Router(config-subif)# **encapsulation frame-relay**

DETAILED STEPS

	Command or Action	Purpose
Step 1	Router(config)# interface type number . subinterface-number { multipoint point-to-point }	Creates a point-to-point or multipoint subinterface.
Step 2	Router(config-subif)# encapsulation frame-relay	Configures Frame Relay encapsulation on the serial interface.

Defining Subinterface Addressing on Point-to-Point Subinterfaces

If you specified a point-to-point subinterface in the preceding procedure, use the following command in subinterface configuration mode:

SUMMARY STEPS

1. Router(config-subif)# **frame-relay interface-dlci** *dlci*

DETAILED STEPS

Command or Action	Purpose
Step 1 Router(config-subif)# frame-relay interface-dlci <i>dlci</i>	Associates the selected point-to-point subinterface with a DLCI.

Accepting Inverse ARP for Dynamic Address Mapping on Multipoint Subinterfaces

To associate a specific multipoint subinterface with a specific DLCI, use the following command in interface configuration mode:

Command	Purpose
Router(config-if)# frame-relay interface-dlci <i>dlci</i>	Associates a specified multipoint subinterface with a DLCI.

Configuring Static Address Mapping on Multipoint Subinterfaces

To establish static mapping according to your network needs, use one of the following commands in interface configuration mode:

Command	Purpose
Router(config-if)# frame-relay map <i>protocol protocol-address dlci</i> [broadcast] [ietf] [cisco]	Maps between a next-hop protocol address and DLCI destination address. The supported protocols and the corresponding keywords to enable them are as follows: <ul style="list-style-type: none"> • IP--ip • DECnet--decnet • AppleTalk--appletalk • XNS--xns • Novell IPX--ipx • VINES--vines • ISO CLNS--clns
Router(config-if)# frame-relay map clns <i>dlci</i> [broadcast]	Defines a DLCI used to send ISO CLNS frames. The broadcast keyword is required for routing protocols such as OSI protocols and the Open Shortest Path First (OSPF) protocol.
Router(config-if)# frame-relay map bridge <i>dlci</i> [broadcast] [ietf]	Defines a DLCI destination bridge.

Configuring Transparent Bridging for Point-to-Point Subinterfaces



Note All PVCs configured on a subinterface belong to the same bridge group.

To configure transparent bridging for point-to-point subinterfaces, use the following commands beginning in global configuration mode:

SUMMARY STEPS

1. Router(config)# **interface type number**
2. Router(config-if)# **encapsulation frame-relay**
3. Router(config)# **interface type number : subinterface-number point-to-point**
4. Router(config-subif)# **frame-relay interface-dlci dlci**
5. Router(config-subif)# **bridge-group bridge-group**

DETAILED STEPS

	Command or Action	Purpose
Step 1	Router(config)# interface type number	Specifies an interface.
Step 2	Router(config-if)# encapsulation frame-relay	Configures Frame Relay encapsulation on the interface.
Step 3	Router(config)# interface type number : subinterface-number point-to-point	Specifies a subinterface.
Step 4	Router(config-subif)# frame-relay interface-dlci dlci	Associates a DLCI with the subinterface.
Step 5	Router(config-subif)# bridge-group bridge-group	Associates the subinterface with a bridge group.

Configuring Transparent Bridging for Point-to-Multipoint Interfaces



Note All PVCs configured on a subinterface belong to the same bridge group.

To configure transparent bridging for point-to-multipoint subinterfaces, use the following commands beginning in global configuration mode:

SUMMARY STEPS

1. Router(config)# **interface type number**
2. Router(config-if)# **encapsulation frame-relay**
3. Router(config)# **interface typenumber:subinterface-number multipoint**
4. Router(config-subif)# **frame-relay map bridge dlci [broadcast] [ietf]**
5. Router(config-subif)# **bridge-group bridge-group**

DETAILED STEPS

	Command or Action	Purpose
Step 1	Router(config)# interface type number	Specifies an interface.
Step 2	Router(config-if)# encapsulation frame-relay	Configures Frame Relay encapsulation.
Step 3	Router(config)# interface typenumber:subinterface-number multipoint	Specifies a subinterface.
Step 4	Router(config-subif)# frame-relay map bridge dlci [broadcast] [ietf]	Defines a DLCI destination bridge.
Step 5	Router(config-subif)# bridge-group bridge-group	Associates the subinterface with a bridge group.

Configuring a Backup Interface for a Subinterface

To configure a backup interface for a Frame Relay subinterface, use the following commands beginning in global configuration mode:

SUMMARY STEPS

1. Router(config)# **interface type number**
2. Router(config-if)# **encapsulation frame-relay**
3. Router(config)# **interface type number . subinterface-number point-to-point**
4. Router(config-subif)# **frame-relay interface-dlci dlci**
5. Router(config-subif)# **backup interface type number**
6. Router(config-subif)# **backup delay enable-delay disable-delay**

DETAILED STEPS

	Command or Action	Purpose
Step 1	Router(config)# interface type number	Specifies the interface.
Step 2	Router(config-if)# encapsulation frame-relay	Configures Frame Relay encapsulation.
Step 3	Router(config)# interface type number . subinterface-number point-to-point	Configures the subinterface.
Step 4	Router(config-subif)# frame-relay interface-dlci dlci	Specifies DLCI for the subinterface.
Step 5	Router(config-subif)# backup interface type number	Configures backup interface for the subinterface.
Step 6	Router(config-subif)# backup delay enable-delay disable-delay	Specifies backup enable and disable delay.

Disabling or Reenabling Frame Relay Inverse ARP

To select or disable Inverse ARP, use one of the following commands in interface configuration mode:

Command	Purpose
frame-relay inverse-arp <i>protocol dlc</i>	Enables Frame Relay Inverse ARP for a specific protocol and DLCI pair, only if it was previously disabled.
no frame relay inverse-arp <i>protocol dlc</i>	Disables Frame Relay Inverse ARP for a specific protocol and DLCI pair.

Creating a Broadcast Queue for an Interface

To create a broadcast queue, use the following command in interface configuration mode:

Command	Purpose
Router(config-if)# frame-relay broadcast-queue <i>size byte-rate packet-rate</i>	Creates a broadcast queue for an interface.

Configuring Frame Relay Fragmentation

- [Configuring End-to-End FRF.12 Fragmentation, page 54](#)
- [Verifying the Configuration of End-to-End FRF.12 Fragmentation, page 54](#)

Configuring End-to-End FRF.12 Fragmentation

To configure FRF.12 fragmentation in a Frame Relay map class, use the following commands beginning in global configuration mode:

SUMMARY STEPS

1. Router(config)# **map-class frame-relay** *map-class-name*
2. Router(config-map-class)# **frame-relay fragment** *fragment_size*

DETAILED STEPS

	Command or Action	Purpose
Step 1	Router(config)# map-class frame-relay <i>map-class-name</i>	Specifies a map class to define QoS values for a Frame Relay SVC or PVC. The map class can be applied to one or many PVCs.
Step 2	Router(config-map-class)# frame-relay fragment <i>fragment_size</i>	Configures Frame Relay fragmentation for the map class. The <i>fragment_size</i> argument defines the payload size of a fragment; it excludes the Frame Relay headers and any Frame Relay fragmentation header. The valid range is from 16 to 1600 bytes, and the default is 53.

Verifying the Configuration of End-to-End FRF.12 Fragmentation

To verify FRF.12 fragmentation, use one or more of the following EXEC commands:

Command	Purpose
show frame-relay fragment [<i>interface interface</i>] [<i>dldi</i>]	Displays Frame Relay fragmentation information.
show frame-relay pvc [<i>interface interface</i>] [<i>dldi</i>]	Displays statistics about PVCs for Frame Relay interfaces.

Configuring Payload Compression

- [Configuring Payload Compression On a Multipoint Interface or Subinterface, page 55](#)
- [Configuring Payload Compression On a Point-to-Point Interface or Subinterface, page 55](#)
- [Configuring FRF.9 Compression Using Map Statements, page 55](#)
- [Configuring FRF.9 Compression on the Subinterface, page 56](#)
- [Configuring Data-Stream Hardware Compression and IP Header Compression on a Point-to-Point Subinterface, page 56](#)
- [Configuring Data-Stream Hardware Compression and IP Header Compression on a Multipoint Subinterface, page 57](#)
- [Verifying Payload Compression, page 58](#)

Configuring Payload Compression On a Multipoint Interface or Subinterface

To configure payload compression on a specified multipoint interface or subinterface, use the following command in interface configuration mode:

Command	Purpose
Router(config-if)# frame-relay map <i>protocol address dldi</i> payload- compression packet-by-packet	Enables payload compression on a multipoint interface.

Configuring Payload Compression On a Point-to-Point Interface or Subinterface

To configure payload compression on a specified point-to-point interface or subinterface, use the following command in interface configuration mode:

Command	Purpose
Router(config-if)# frame-relay payload- compression packet-by-packet	Enables payload compression on a point-to-point interface.

Configuring FRF.9 Compression Using Map Statements

You can control where you want compression to occur by specifying an interface. To enable FRF.9 compression on a specific CSA, VIP CPU, or host CPU, use the following commands beginning in global configuration mode:

SUMMARY STEPS

1. Router(config)# **interface** *type number*
2. Router(config-if)# **encapsulation frame-relay**
3. Router(config-if)# **frame-relay map payload-compression frf9 stac**[*hardware-options*]

DETAILED STEPS

	Command or Action	Purpose
Step 1	Router(config)# interface <i>type number</i>	Specifies the interface.
Step 2	Router(config-if)# encapsulation frame-relay	Specifies Frame Relay as encapsulation type.
Step 3	Router(config-if)# frame-relay map payload-compression frf9 stac [<i>hardware-options</i>]	Enables FRF.9 compression.

Configuring FRF.9 Compression on the Subinterface

To configure FRF.9 compression on the subinterface, use the following commands beginning in global configuration mode:

SUMMARY STEPS

1. Router(config)# **interface** *type number*
2. Router(config-subif)# **encapsulation frame-relay**
3. Router(config-subif)# **frame-relay payload-compression frf9 stac**[*hardware-options*]

DETAILED STEPS

	Command or Action	Purpose
Step 1	Router(config)# interface <i>type number</i>	Specifies the subinterface type and number.
Step 2	Router(config-subif)# encapsulation frame-relay	Specifies Frame Relay as encapsulation type.
Step 3	Router(config-subif)# frame-relay payload-compression frf9 stac [<i>hardware-options</i>]	Enables FRF.9 compression.

Configuring Data-Stream Hardware Compression and IP Header Compression on a Point-to-Point Subinterface

To configure data-stream hardware compression and TCP or Real-Time Transport Protocol (RTP) header compression on a point-to-point subinterface, use the following commands beginning in global configuration mode. Note that when you specify data-stream hardware compression, Cisco-proprietary encapsulation is automatically enabled.

SUMMARY STEPS

1. Router(config)# **interface** *type number point-to-point*
2. Router(config-subif)# **ip address** *address mask*
3. Router(config-subif)# **frame-relay interface-dlci** *dlci*
4. Router(config-subif)# **frame-relay payload-compression data-stream stac** [*hardware-options*]
5. Do one of the following:
 - Router(config-subif)# **frame-relay ip tcp header-compression** [*passive*]
 -
 -
 -
 -

DETAILED STEPS

	Command or Action	Purpose
Step 1	Router(config)# interface <i>type number point-to-point</i>	Configures a subinterface type and enters subinterface configuration mode.
Step 2	Router(config-subif)# ip address <i>address mask</i>	Sets the IP address for an interface.
Step 3	Router(config-subif)# frame-relay interface-dlci <i>dlci</i>	Assigns a DLCI to a specified Frame Relay subinterface on the router or access server.
Step 4	Router(config-subif)# frame-relay payload-compression data-stream stac [<i>hardware-options</i>]	Enables hardware compression on an interface or subinterface that uses Cisco-proprietary encapsulation.
Step 5	Do one of the following: <ul style="list-style-type: none"> • Router(config-subif)# frame-relay ip tcp header-compression [<i>passive</i>] • • • • Example: <pre>Router(config-subif)# frame-relay ip rtp header-compression [passive]</pre>	Configures an interface to ensure that the associated PVCs carry outgoing TCP headers in compressed form. Enables RTP header compression on the physical interface.

Configuring Data-Stream Hardware Compression and IP Header Compression on a Multipoint Subinterface

To configure data-stream hardware compression and TCP or RTP header compression on a multipoint subinterface, use the following commands beginning in global configuration mode. Note that when you specify data-stream hardware compression, Cisco-proprietary encapsulation is automatically enabled.

SUMMARY STEPS

1. Router(config)# **interface** *type number* **multipoint**
2. Router(config-subif)# **frame-relay interface-dlci** dlci
3. Router(config-subif)# **frame-relay map** protocol protocol-address dlci [**payload-compression data-stream stac** [*hardware-options*]]
4. Do one of the following:
 - Router(config-subif)# **frame-relay ip tcp header-compression** [**passive**]
 -
 -
 -
 -

DETAILED STEPS

	Command or Action	Purpose
Step 1	Router(config)# interface <i>type number</i> multipoint	Configures a subinterface type and enters subinterface configuration mode.
Step 2	Router(config-subif)# frame-relay interface-dlci dlci	Assigns a DLCI to a specified Frame Relay subinterface on the router or access server.
Step 3	Router(config-subif)# frame-relay map protocol protocol-address dlci [payload-compression data-stream stac [<i>hardware-options</i>]]	Defines the mapping between a destination protocol address and the DLCI used to connect to the destination address on an interface that uses Cisco-proprietary encapsulation.
Step 4	Do one of the following: <ul style="list-style-type: none"> • Router(config-subif)# frame-relay ip tcp header-compression [passive] • • • • <p>Example:</p> <pre>Router(config-subif)# frame-relay ip rtp header-compression [passive]</pre>	Configures an interface to ensure that the associated PVCs carry outgoing TCP headers in compressed form. Enables RTP header compression on the physical interface.

Verifying Payload Compression

To verify that payload compression is working correctly, use the following privileged EXEC commands:

Command	Purpose
Router# show compress	Displays compression statistics.

Command	Purpose
Router# show frame-relay pvc dlcid	Displays statistics about PVCs for Frame Relay interfaces, including the number of packets in the post-hardware-compression queue.
Router# show traffic-shape queue	Displays information about the elements queued at a particular time at the DLCI level, including the number of packets in the post-hardware-compression queue.

Configuring TCP/IP Header Compression

- [Configuring an Individual IP Map for TCP/IP Header Compression, page 59](#)
- [Configuring an Interface for TCP/IP Header Compression, page 59](#)
- [Disabling TCP/IP Header Compression, page 59](#)

Configuring an Individual IP Map for TCP/IP Header Compression

To configure an IP map to use Cisco-proprietary encapsulation and TCP/IP header compression, use the following command in interface configuration mode:

Command	Purpose
frame-relay map ip <i>ip-address dlcid</i> [broadcast] tcp header-compression [active passive] [connections <i>number</i>]	Configures an IP map to use TCP/IP header compression. Cisco-proprietary encapsulation is enabled by default.

Configuring an Interface for TCP/IP Header Compression

To apply TCP/IP header compression to an interface, you must use the following commands in interface configuration mode:

SUMMARY STEPS

1. Router(config-if)# **encapsulation frame-relay**
2. Router(config-if)# **frame-relay ip tcp header-compression** [**passive**]

DETAILED STEPS

	Command or Action	Purpose
Step 1	Router(config-if)# encapsulation frame-relay	Configures Cisco-proprietary encapsulation on the interface.
Step 2	Router(config-if)# frame-relay ip tcp header-compression [passive]	Enables TCP/IP header compression.

Disabling TCP/IP Header Compression

You can disable TCP/IP header compression by using either of two commands that have different effects, depending on whether Frame Relay IP maps have been explicitly configured for TCP/IP header compression or have inherited their compression characteristics from the interface.

Frame Relay IP maps that have explicitly configured TCP/IP header compression must also have TCP/IP header compression explicitly disabled.

To disable TCP/IP header compression, use one of the following commands in interface configuration mode:

Command	Purpose
no frame-relay ip tcp header-compression	Disables TCP/IP header compression on all Frame Relay IP maps that are not explicitly configured for TCP header compression.
frame-relay map ip <i>ip-address dlc</i> nocompress	Disables RTP and TCP/IP header compression on a specified Frame Relay IP map.

Configuring Discard Eligibility

- [Defining a DE List, page 60](#)
- [Defining a DE Group, page 60](#)

Defining a DE List

To define a DE list specifying the packets that can be dropped when the Frame Relay switch is congested, use the following command in global configuration mode:

SUMMARY STEPS

1. Router(config)# **frame-relay de-list** *list-number* {**protocol** *protocol* | **interface** *type number*} *characteristic*

DETAILED STEPS

Command or Action	Purpose
Step 1 Router(config)# frame-relay de-list <i>list-number</i> { protocol <i>protocol</i> interface <i>type number</i> } <i>characteristic</i>	Defines a DE list.

Defining a DE Group

To define a DE group specifying the DE list and DLCI affected, use the following command in interface configuration mode:

Command	Purpose
frame-relay de-group <i>group-number dlc</i>	Defines a DE group.

Configuring DLCI Priority Levels

To configure DLCI priority levels, use the following command in interface configuration mode:

Command	Purpose
frame-relay priority-dlci-group <i>group-number high-dlci medium-dlci normal-dlci low-dlci</i>	<p>Enables multiple parallel DLCIs for different Frame Relay traffic types; associates and sets level of specified DLCIs with same group.</p> <p>Note If you do not explicitly specify a DLCI for each of the priority levels, the last DLCI specified in the command line is used as the value of the remaining arguments. At a minimum, you must configure the high-priority and the medium-priority DLCIs.</p>

Monitoring and Maintaining the Frame Relay Connections

To monitor Frame Relay connections, use any of the following commands in EXEC mode:

Command	Purpose
clear frame-relay inarp	Clears dynamically created Frame Relay maps, which are created by the use of Inverse ARP.
show interfaces serial <i>type number</i>	Displays information about Frame Relay DLCIs and the LMI.
show frame-relay lmi [<i>type number</i>]	Displays LMI statistics.
show frame-relay map	Displays the current Frame Relay map entries.
show frame-relay pvc [<i>type number [dlci]</i>]	Displays PVC statistics.
show frame-relay route	Displays configured static routes.
show frame-relay traffic	Displays Frame Relay traffic statistics.
show frame-relay lapf	Displays information about the status of LAPF.
show frame-relay svc maplist	Displays all the SVCs under a specified map list.

Configuration Examples for Frame Relay

- [Example IETF Encapsulation, page 62](#)
- [Example Static Address Mapping, page 62](#)
- [Example Subinterface, page 63](#)
- [Example SVC Configuration, page 65](#)
- [Example Frame Relay Traffic Shaping, page 66](#)
- [Example Backward Compatibility, page 69](#)
- [Example Booting from a Network Server over Frame Relay, page 70](#)
- [Example Frame Relay Switching, page 70](#)
- [Example Frame Relay End-to-End Keepalive, page 77](#)

- [Example PPPoverFrameRelay, page 79](#)
- [Example Frame Relay Fragmentation Configuration, page 80](#)
- [Example Payload Compression Configuration, page 81](#)
- [Example TCP IP Header Compression, page 82](#)

Example IETF Encapsulation

- [Example IETF Encapsulation on the Interface, page 62](#)
- [Example IETF Encapsulation on a Per-DLCI Basis, page 62](#)

Example IETF Encapsulation on the Interface

The following example sets IETF encapsulation at the interface level. The keyword **ietf** sets the default encapsulation method for all maps to IETF.

```
encapsulation frame-relay ietf
frame-relay map ip 131.108.123.2 48 broadcast
frame-relay map ip 131.108.123.3 49 broadcast
```

Example IETF Encapsulation on a Per-DLCI Basis

The following example configures IETF encapsulation on a per-DLCI basis. This configuration has the same result as the configuration in the first example.

```
encapsulation frame-relay
frame-relay map ip 131.108.123.2 48 broadcast ietf
frame-relay map ip 131.108.123.3 49 broadcast ietf
```

Example Static Address Mapping

- [Example Two Routers in Static Mode, page 62](#)
- [Example AppleTalk Routing, page 63](#)
- [Example DECnet Routing, page 63](#)
- [Example IPX Routing, page 63](#)

Example Two Routers in Static Mode

The following example shows how to configure two routers for static mode:

Configuration for Router 1

```
interface serial0
ip address 131.108.64.2 255.255.255.0
encapsulation frame-relay
keepalive 10
frame-relay map ip 131.108.64.1 43
```

Configuration for Router 2

```
interface serial1
ip address 131.108.64.1 255.255.255.0
encapsulation frame-relay
keepalive 10
frame-relay map ip 131.108.64.2 43
```

Example AppleTalk Routing

The following example shows how to configure two routers to communicate with each other using AppleTalk over a Frame Relay network. Each router has a Frame Relay static address map for the other router. The use of the **appletalk cable-range** command indicates that this is extended AppleTalk (Phase II).

Configuration for Router 1

```
interface serial0
 ip address 172.21.59.24 255.255.255.0
 encapsulation frame-relay
 appletalk cable-range 10-20 18.47
 appletalk zone eng
 frame-relay map appletalk 18.225 100 broadcast
```

Configuration for Router 2

```
interface serial2/3
 ip address 172.21.177.18 255.255.255.0
 encapsulation frame-relay
 appletalk cable-range 10-20 18.225
 appletalk zone eng
 clockrate 2000000
 frame-relay map appletalk 18.47 100 broadcast
```

Example DECnet Routing

The following example sends all DECnet packets destined for address 56.4 out on DLCI 101. In addition, any DECnet broadcasts for interface serial 1 will be sent on that DLCI.

```
decnet routing 32.6
!
interface serial 1
 encapsulation frame-relay
 frame-relay map decnet 56.4 101 broadcast
```

Example IPX Routing

The following example shows how to send packets destined for IPX address 200.0000.0c00.7b21 out on DLCI 102:

```
ipx routing 000.0c00.7b3b
!
interface ethernet 0
 ipx network 2abc
!
interface serial 0
 ipx network 200
 encapsulation frame-relay
 frame-relay map ipx 200.0000.0c00.7b21 102 broadcast
```

Example Subinterface

- [Example Basic Subinterface, page 64](#)
- [Example Frame Relay Multipoint Subinterface with Dynamic Addressing, page 64](#)
- [Example IPX Routes over Frame Relay Subinterfaces, page 64](#)

- [Example Unnumbered IP over a Point-to-Point Subinterface](#), page 65
- [Example Transparent Bridging Using Subinterfaces](#), page 65

Example Basic Subinterface

In the following example, subinterface 1 is configured as a point-to-point subnet and subinterface 2 is configured as a multipoint subnet.

```
interface serial 0
 encapsulation frame-relay
 interface serial 0.1 point-to-point
 ip address 10.0.1.1 255.255.255.0
 frame-relay interface-dlci 42
 !
 interface serial 0.2 multipoint
 ip address 10.0.2.1 255.255.255.0
 frame-relay map ip 10.0.2.2 18
```

Example Frame Relay Multipoint Subinterface with Dynamic Addressing

The following example configures two multipoint subinterfaces for dynamic address resolution. Each subinterface is provided with an individual protocol address and subnet mask, and the **frame-relay interface-dlci** command associates the subinterface with a specified DLCI. Addresses of remote destinations for each multipoint subinterface will be resolved dynamically.

```
interface serial0
 no ip address
 encapsulation frame-relay
 frame-relay lmi-type ansi
 !
 interface serial0.103 multipoint
 ip address 172.21.177.18 255.255.255.0
 frame-relay interface-dlci 300
 !
 interface serial0.104 multipoint
 ip address 172.21.178.18 255.255.255.0
 frame-relay interface-dlci 400
```

Example IPX Routes over Frame Relay Subinterfaces

The following example configures a serial interface for Frame Relay encapsulation and sets up multiple IPX virtual networks corresponding to Frame Relay subinterfaces:

```
ipx routing 0000.0c02.5f4f
 !
 interface serial 0
 encapsulation frame-relay
 interface serial 0.1 multipoint
 ipx network 1
 frame-relay map ipx 1.000.0c07.d530 200 broadcast
 interface serial 0.2 multipoint
 ipx network 2
 frame-relay map ipx 2.000.0c07.d530 300 broadcast
```

For subinterface serial 0.1, the router at the other end might be configured as follows:

```
ipx routing
 interface serial 2 multipoint
 ipx network 1
 frame-relay map ipx 1.000.0c02.5f4f 200 broadcast
```

Example Unnumbered IP over a Point-to-Point Subinterface

The following example sets up unnumbered IP over subinterfaces at both ends of a point-to-point connection. In this example, router A functions as the DTE, and router B functions as the DCE. Routers A and B are both attached to Token Ring networks.

Configuration for Router A

```
interface token-ring 0
 ip address 131.108.177.1 255.255.255.0
!
interface serial 0
 no ip address
 encapsulation frame-relay IETF
!
interface serial0.2 point-to-point
 ip unnumbered TokenRing0
 ip pim sparse-mode
 frame-relay interface-dlci 20
```

Configuration for Router B

```
frame-relay switching
!
interface token-ring 0
 ip address 131.108.178.1 255.255.255.0
!
interface serial 0
 no ip address
 encapsulation frame-relay IETF
 bandwidth 384
 clockrate 4000000
 frame-relay intf-type dce
!
interface serial 0.2 point-to-point
 ip unnumbered TokenRing1
 ip pim sparse-mode
!
 bandwidth 384
 frame-relay interface-dlci 20
```

Example Transparent Bridging Using Subinterfaces

The following example shows Frame Relay DLCIs 42, 64, and 73 as separate point-to-point links with transparent bridging running over them. The bridging spanning tree views each PVC as a separate bridge port, and a frame arriving on the PVC can be relayed back out on a separate PVC.

```
interface serial 0
 encapsulation frame-relay
interface serial 0.1 point-to-point
 bridge-group 1
 frame-relay interface-dlci 42
interface serial 0.2 point-to-point
 bridge-group 1
 frame-relay interface-dlci 64
interface serial 0.3 point-to-point
 bridge-group 1
 frame-relay interface-dlci 73
```

Example SVC Configuration

- [Example SVC Interface, page 66](#)
- [Example SVC Subinterface, page 66](#)

Example SVC Interface

The following example configures a physical interface, applies a map group to the physical interface, and then defines the map group:

```
interface serial 0
 ip address 172.10.8.6
 encapsulation frame-relay
 map-group bermuda
 frame-relay lmi-type q933a
 frame-relay svc
!
map-list bermuda source-addr E164 123456 dest-addr E164 654321
 ip 131.108.177.100 class hawaii
 appletalk 1000.2 class rainbow
!
map-class frame-relay rainbow
 frame-relay idle-timer 60
!
map-class frame-relay hawaii
 frame-relay cir in 64000
 frame-relay cir out 64000
```

Example SVC Subinterface

The following example configures a point-to-point interface for SVC operation. It assumes that the main serial 0 interface has been configured for signalling and that SVC operation has been enabled on the main interface:

```
int s 0.1 point-point
! Define the map-group; details are specified under the map-list holiday command.
map-group holiday
!
! Associate the map-group with a specific source and destination.
map-list holiday local-addr X121 <X121-addr> dest-addr E164 <E164-addr>
! Specify destination protocol addresses for a map-class.
 ip 131.108.177.100 class hawaii IETF
 appletalk 1000.2 class rainbow IETF broadcast
!
! Define a map class and its QoS settings.
map-class hawaii
 frame-relay cir in 2000000
 frame-relay cir out 56000
 frame-relay be 9000
!
! Define another map class and its QoS settings.
map-class rainbow
 frame-relay cir in 64000
 frame-relay idle-timer 2000
```

Example Frame Relay Traffic Shaping

- [Example Traffic Shaping with Three Point-to-Point Subinterfaces, page 67](#)
- [Example Traffic Shaping with ForeSight, page 68](#)
- [Example LMI Configuration, page 68](#)

Example Traffic Shaping with Three Point-to-Point Subinterfaces

In the following example, VCs on subinterfaces Serial0.1 and Serial0.2 inherit class parameters from the main interface--namely, those defined in the map class "slow_vcs"--but the VC defined on subinterface Serial0.2 (DLCI 102) is specifically configured to use map class "fast_vcs".

Map class "slow_vcs" uses a peak rate of 9600 and average rate of 4800 bps. Because BECN feedback is enabled, the output rate will be cut back to as low as 2400 bps in response to received BECNs. This map class is configured to use custom queueing using queue-list 1. In this example, queue-list 1 has 3 queues, with the first two being controlled by access lists 100 and 115.

Map class "fast_vcs" uses a peak rate of 64000 and average rate of 16000 bps. Because BECN feedback is enabled, the output rate will be cut back to as low as 8000 bps in response to received BECNs. This map class is configured to use priority-queueing using priority-group 2.

```
interface serial0
  no ip address
  encapsulation frame-relay
  frame-relay lmi-type ansi
  frame-relay traffic-shaping
  frame-relay class slow_vcs
!
interface serial0.1 point-to-point
  ip address 10.128.30.1 255.255.255.248
  ip ospf cost 200
  bandwidth 10
  frame-relay interface-dlci 101
!
interface serial0.2 point-to-point
  ip address 10.128.30.9 255.255.255.248
  ip ospf cost 400
  bandwidth 10
  frame-relay interface-dlci 102
  class fast_vcs
!
interface serial0.3 point-to-point
  ip address 10.128.30.17 255.255.255.248
  ip ospf cost 200
  bandwidth 10
  frame-relay interface-dlci 103
!
map-class frame-relay slow_vcs
  frame-relay traffic-rate 4800 9600
  frame-relay custom-queue-list 1
  frame-relay adaptive-shaping becn
!
map-class frame-relay fast_vcs
  frame-relay traffic-rate 16000 64000
  frame-relay priority-group 2
  frame-relay adaptive-shaping becn
!
access-list 100 permit tcp any any eq 2065
access-list 115 permit tcp any any eq 256
!
priority-list 2 protocol decnet high
priority-list 2 ip normal
priority-list 2 default medium
!
queue-list 1 protocol ip 1 list 100
queue-list 1 protocol ip 2 list 115
queue-list 1 default 3
queue-list 1 queue 1 byte-count 1600 limit 200
queue-list 1 queue 2 byte-count 600 limit 200
queue-list 1 queue 3 byte-count 500 limit 200
```

Example Traffic Shaping with ForeSight

The following example illustrates a router configuration with traffic shaping enabled. DLCIs 100 and 101 on subinterfaces Serial 13.2 and Serial 13.3 inherit class parameters from the main interface. The traffic shaping for these two VCs will be adaptive to the ForeSight notification.

For Serial 0, the output rate for DLCI 103 will not be affected by the router ForeSight function.

```
interface Serial0
  no ip address
  encapsulation frame-relay
  frame-relay lmi-type ansi
  frame-relay traffic-shaping
!
interface Serial0.2 point-to-point
  ip address 10.128.30.17 255.255.255.248
  frame-relay interface-dlci 102
  class fast_vcs
!
interface Serial0.3 point-to-point
  ip address 10.128.30.5 255.255.255.248
  ip ospf cost 200
  frame-relay interface-dlci 103
  class slow_vcs
!
interface serial 3
  no ip address
  encapsulation frame-relay
  frame-relay traffic-shaping
  frame-relay class fast_vcs
!
interface Serial3.2 multipoint
  ip address 100.120.20.13 255.255.255.248
  frame-relay map ip 100.120.20.6 16 ietf broadcast
!
interface Serial3.3 point-to-point
  ip address 100.120.10.13 255.255.255.248
  frame-relay interface-dlci 101
!
map-class frame-relay slow_vcs
  frame-relay adaptive-shaping becn
  frame-relay traffic-rate 4800 9600
!
map-class frame-relay fast_vcs
  frame-relay adaptive-shaping foresight
  frame-relay traffic-rate 16000 64000
  frame-relay cir 56000
  frame-relay bc 64000
```

Example LMI Configuration

- [Example ELMI and Frame Relay Traffic Shaping, page 68](#)
- [Example Configuring the IP Address for ELMI Address Registration, page 69](#)
- [Example Disabling ELMI Address Registration on an Interface, page 69](#)

Example ELMI and Frame Relay Traffic Shaping

The following configuration shows a Frame Relay interface enabled with QoS autosense. The router receives messages from the Cisco switch, which is also configured with QoS autosense enabled. When ELMI is configured in conjunction with traffic shaping, the router will receive congestion information

through BECN or router ForeSight congestion signalling and reduce its output rate to the value specified in the traffic shaping configuration.

```
interface serial0
  no ip address
  encapsulation frame-relay
  frame-relay lmi-type ansi
  frame-relay traffic-shaping
  frame-relay QoS-autosense
!
interface serial0.1 point-to-point
  no ip address
  frame-relay interface-dlci 101
```

Example Configuring the IP Address for ELMI Address Registration

The following example shows how to configure the IP address to be used for ELMI address registration. Automatic IP address selection is automatically disabled when the IP address is configured. ELMI is enabled on serial interface 0.

```
interface Serial 0
  no ip address
  encapsulation frame-relay
  frame-relay lmi-type ansi
  frame-relay qos-autosense
!
frame-relay address registration ip address 139.85.242.195
!
```

Example Disabling ELMI Address Registration on an Interface

In the following example, ELMI address registration is disabled on serial interface 0. This interface will share an IP address of 0.0.0.0 and an ifIndex of 0. Automatic IP address selection is enabled by default when ELMI is enabled, so the management IP address of other interfaces on this router will be chosen automatically.

```
interface Serial 0
  no ip address
  encapsulation frame-relay
  frame-relay lmi-type ansi
  frame-relay qos-autosense
  no frame-relay address-reg-enable
!
```

Example Backward Compatibility

The following configuration provides backward compatibility and interoperability with versions not compliant with RFC 1490. The **ietf** keyword is used to generate RFC 1490 traffic. This configuration is possible because of the flexibility provided by separately defining each map entry.

```
encapsulation frame-relay
frame-relay map ip 131.108.123.2 48 broadcast ietf
! interoperability is provided by IETF encapsulation
frame-relay map ip 131.108.123.3 49 broadcast ietf
frame-relay map ip 131.108.123.7 58 broadcast
! this line allows the router to connect with a
! device running an older version of software
frame-relay map decnet 21.7 49 broadcast
```

Example Booting from a Network Server over Frame Relay

When booting from a TFTP server over Frame Relay, you cannot boot from a network server via a broadcast. You must boot from a specific TFTP host. Also, a **frame-relay map** command must exist for the host from which you will boot.

For example, if file "gs3-bfx" is to be booted from a host with IP address 131.108.126.2, the following commands would need to be in the configuration:

```
boot system gs3-bfx 131.108.126.2
!
interface Serial 0
 encapsulation frame-relay
 frame-relay map IP 131.108.126.2 100 broadcast
```

The **frame-relay map** command is used to map an IP address into a DLCI address. To boot over Frame Relay, you must explicitly give the address of the network server to boot from, and a **frame-relay map** entry must exist for that site. For example, if file "gs3-bfx.83-2.0" is to be booted from a host with IP address 131.108.126.111, the following commands must be in the configuration:

```
boot system gs3-bfx.83-2.0 131.108.13.111
!
interface Serial 1
 ip address 131.108.126.200 255.255.255.0
 encapsulation frame-relay
 frame-relay map ip 131.108.126.111 100 broadcast
```

In this case, 100 is the DLCI that can get to host 131.108.126.111.

The remote router must be configured with the following command:

```
frame-relay map ip 131.108.126.200 101 broadcast
```

This entry allows the remote router to return a boot image (from the network server) to the router booting over Frame Relay. Here, 101 is a DLCI of the router being booted.

Example Frame Relay Switching

- [Example PVC Switching Configuration, page 70](#)
- [Example Pure Frame Relay DCE, page 71](#)
- [Example Hybrid DTE DCE PVC Switching, page 72](#)
- [Example Switching over an IP Tunnel, page 73](#)
- [Example Frame Relay Switching over ISDN B Channels, page 75](#)
- [Example Traffic Shaping on Switched PVCs, page 75](#)
- [Example Traffic Policing on a UNI DCE, page 76](#)
- [Example Congestion Management on Switched PVCs, page 76](#)
- [Example Congestion Management on the Traffic-Shaping Queue of a Switched PVC, page 77](#)
- [Example FRF.12 Fragmentation on a Switched PVC Configuration, page 77](#)

Example PVC Switching Configuration

You can configure your router as a dedicated, DCE-only Frame Relay switch. Switching is based on DLCIs. The incoming DLCI is examined, and the outgoing interface and DLCI are determined. Switching takes place when the incoming DLCI in the packet is replaced by the outgoing DLCI, and the packet is sent out the outgoing interface.

In the figure below, the router switches two PVCs between serial interfaces 1 and 2. Frames with DLCI 100 received on serial 1 will be transmitted with DLCI 200 on serial 2.

Figure 10 PVC Switching Configuration

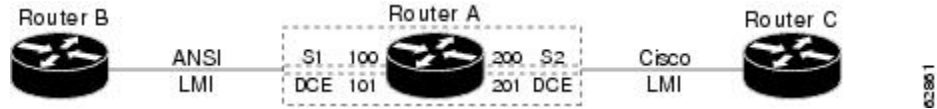

The following example shows one router with two interfaces configured as DCEs. The router switches frames from the incoming interface to the outgoing interface on the basis of the DLCI alone.

Configuration for Router A

```

frame-relay switching
interface Serial1
 no ip address
 encapsulation frame-relay
 keepalive 15
 frame-relay lmi-type ansi
 frame-relay intf-type dce
 frame-relay route 100 interface Serial2 200
 frame-relay route 101 interface Serial2 201
 clockrate 2000000
!
interface Serial2
 encapsulation frame-relay
 keepalive 15
 frame-relay intf-type dce
 frame-relay route 200 interface Serial1 100
 frame-relay route 201 interface Serial1 101
 clockrate 64000
    
```

Example Pure Frame Relay DCE

Using the PVC switching feature, it is possible to build an entire Frame Relay network using routers. In the figure below, router A and router C act as Frame Relay switches implementing a two-node network. The standard Network-to-Network Interface (NNI) signalling protocol is used between router A and router C. The following example shows a Frame Relay network with two routers functioning as switches and standard NNI signalling used between them.

Figure 11 Frame Relay DCE Configuration

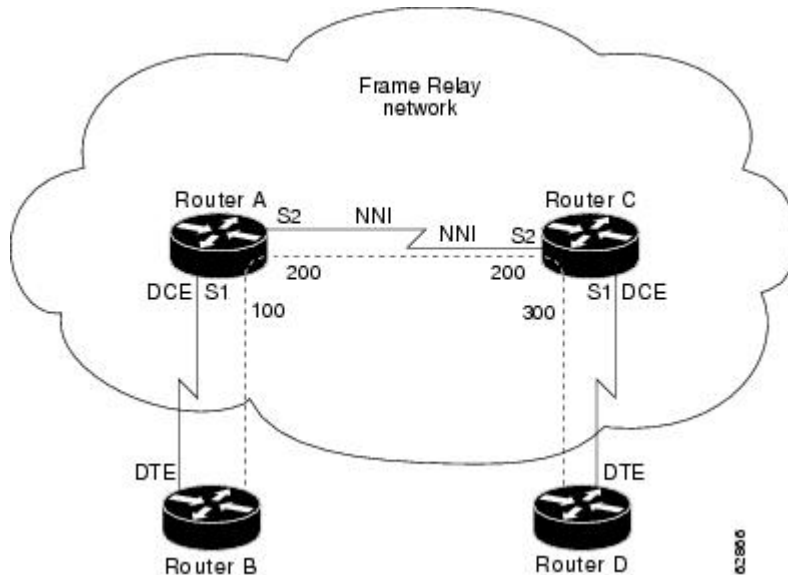

Configuration for Router A

```

frame-relay switching
!
interface serial 1
 no ip address
 encapsulation frame-relay
 frame-relay intf-type dce
 frame-relay lmi-type ansi
 frame-relay route 100 interface serial 2 200
!
interface serial 2
 no ip address
 encapsulation frame-relay
 frame-relay intf-type nni
 frame-relay lmi-type q933a
 frame-relay route 200 interface serial 1 100
 clockrate 2048000
!

```

Configuration for Router C

```

frame-relay switching
!
interface serial 1
 no ip address
 encapsulation frame-relay
 frame-relay intf-type dce
 frame-relay route 300 interface serial 2 200
!
interface serial 2
 no ip address
 encapsulation frame-relay
 frame-relay intf-type nni
 frame-relay lmi-type q933a
 frame-relay route 200 interface serial 1 300
!

```

Example Hybrid DTE DCE PVC Switching

Routers can be configured as hybrid DTE/DCE Frame Relay switches, as shown in the figure below.

Figure 12 Hybrid DTE/DCE PVC Switching

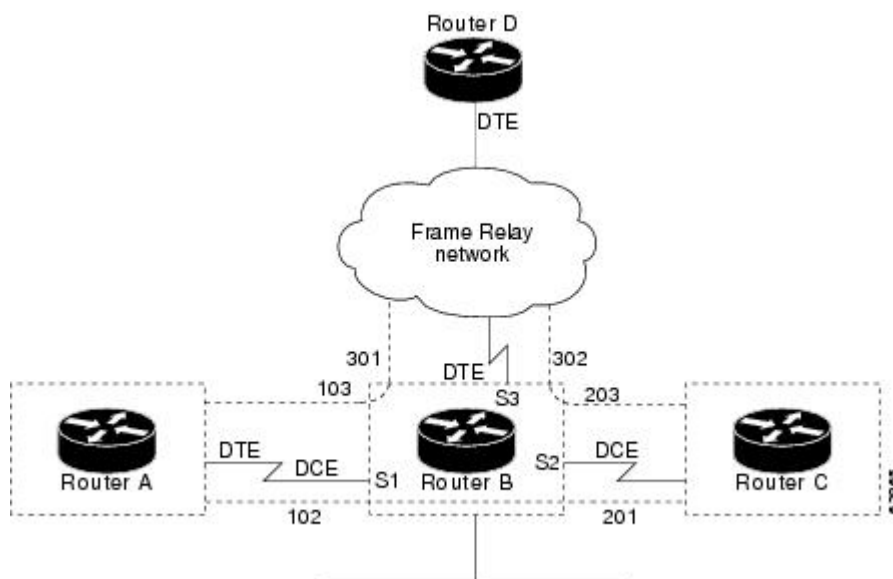

The following example shows one router configured with both DCE and DTE interfaces (router B acts as a hybrid DTE/DCE Frame Relay switch). It can switch frames between two DCE ports and between a DCE port and a DTE port. Traffic from the Frame Relay network can also be terminated locally. In the example, three PVCs are defined as follows:

- Serial 1, DLCI 102, to serial 2, DLCI 201--DCE switching
- Serial 1, DLCI 103, to serial 3, DLCI 301--DCE/DTE switching
- Serial 2, DLCI 203, to serial 3, DLCI 302--DCE/DTE switching

DLCI 400 is also defined for locally terminated traffic.

Configuration for Router B

```

frame-relay switching
!
interface ethernet 0
 ip address 131.108.123.231 255.255.255.0
!
interface ethernet 1
 ip address 131.108.5.231 255.255.255.0
!
interface serial 0
 no ip address
 shutdown :Interfaces not in use may be shut down; shut down is not required.
!
interface serial 1
 no ip address
 encapsulation frame-relay
 frame-relay intf-type dce
 frame-relay route 102 interface serial 2 201
 frame-relay route 103 interface serial 3 301
!
interface serial 2
 no ip address
 encapsulation frame-relay
 frame-relay intf-type dce
 frame-relay route 201 interface serial 1 102
 frame-relay route 203 interface serial 3 302
!
interface serial 3
 ip address 131.108.111.231
 encapsulation frame-relay
 frame-relay lmi-type ansi
 frame-relay route 301 interface serial 1 103
 frame-relay route 302 interface serial 1 203
 frame-relay map ip 131.108.111.4 400 broadcast

```

Example Switching over an IP Tunnel

You can achieve switching over an IP tunnel by creating a point-to-point tunnel across the internetwork over which PVC switching can take place, as shown in the figure below.

**Note**

Static routes cannot be configured over tunnel interfaces on the Cisco 800 series, 1600 series, and 1700 series platforms. Static routes can only be configured over tunnel interfaces on platforms that have the Enterprise feature set.

Figure 13 Frame Relay Switch over IP Tunnel

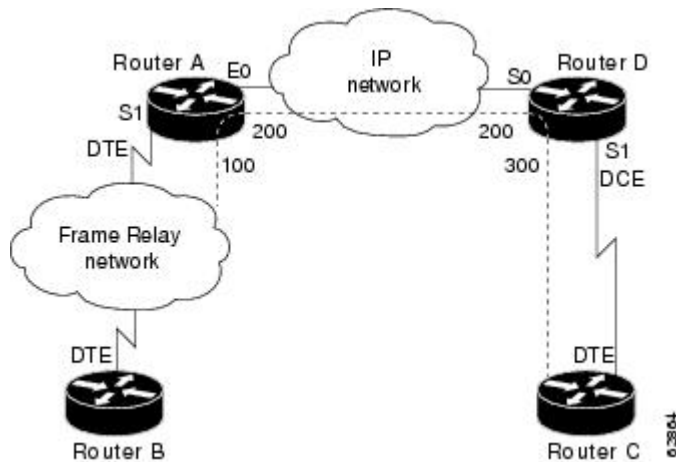

The following example shows two routers configured to switch Frame Relay PVCs over a point-to-point IP tunnel, which is the IP network configuration depicted in the figure above.

Configuration for Router A

```
frame-relay switching
!
interface ethernet0
 ip address 108.131.123.231 255.255.255.0
!
interface ethernet1
 ip address 131.108.5.231 255.255.255.0
!
interface serial0
 no ip address
 shutdown : Interfaces not in use may be shut down; shutdown is not required.
!
interface serial1
 ip address 131.108.222.231 255.255.255.0
 encapsulation frame-relay
 frame-relay map ip 131.108.222.4 400 broadcast
 frame-relay route 100 interface Tunnell 200
!
interface tunnell
 tunnel source Ethernet0
 tunnel destination 150.150.150.123
```

Configuration for Router D

```
frame-relay switching
!
interface ethernet0
 ip address 131.108.231.123 255.255.255.0
!
interface ethernet1
```

```

ip address 131.108.6.123 255.255.255.0
!
interface serial0
ip address 150.150.150.123 255.255.255.0
encapsulation ppp
!
interface tunnel1
tunnel source Serial0
tunnel destination 108.131.123.231
!
interface serial1
ip address 131.108.7.123 255.255.255.0
encapsulation frame-relay
frame-relay intf-type dce
frame-relay route 300 interface Tunnel1 200

```

Example Frame Relay Switching over ISDN B Channels

The following example illustrates Frame Relay switching over an ISDN dialer interface:

```

frame-relay switching
!
interface BRI0
isdn switch-type basic-5ess
dialer pool-member 1
dialer pool-member 2
!
interface dialer1
encapsulation frame-relay
dialer pool 1
dialer-group 1
dialer caller 60038
dialer string 60038
frame-relay intf-type dce
!
interface dialer2
encapsulation frame-relay
dialer pool 2
dialer-group 1
dialer caller 60039
dialer string 60039
frame-relay intf-type dce
!
interface serial0
encapsulation frame-relay
frame-relay intf-type dce
!
connect one serial0 16 dialer1 100
connect two serial0 17 dialer2 100
dialer-list 1 protocol ip permit

```



Note

Note that when Frame Relay switching is performed by using a dialer profile, encapsulation of the underlying physical (BRI) interface must be configured as high-level data link control (HDLC).

Example Traffic Shaping on Switched PVCs

In the example that follows, traffic on serial interface 0 is being shaped prior to entry to the Frame Relay network. PVC 100/16 is shaped according to the "shape256K" class. PVC 200/17 is shaped using the "shape64K" class inherited from the interface.

```

frame-relay switching
!
interface serial0

```

```

encapsulation frame-relay
frame-relay intf-type dce
frame-relay traffic-shaping
frame-relay class shape64K
frame-relay interface-dlci 16 switched
  class shape256K
!
interface serial1
  encapsulation frame-relay
  frame-relay intf-type dce
!
connect one serial0 16 serial1 100
connect two serial0 17 serial1 200
!
map-class frame-relay shape256K
  frame-relay traffic-rate 256000 512000
!
map-class frame-relay shape64K
  frame-relay traffic-rate 64000 64000

```

Example Traffic Policing on a UNI DCE

In the following example, incoming traffic is being policed on serial interface 1. The interface uses policing parameters configured in map class "police256K". PVC 100/16 inherits policing parameters from the interface. PVC 200/17 uses policing parameters configured in "police64K".

```

frame-relay switching
!
interface serial0
  encapsulation frame-relay
  frame-relay intf-type dce
!
interface serial1
  encapsulation frame-relay
  frame-relay policing
  frame-relay class police256K
  frame-relay intf-type dce
  frame-relay interface-dlci 200 switched
    class police64K
!
connect one serial0 16 serial1 100
connect two serial0 17 serial1 200
!
map-class frame-relay police256K
  frame-relay cir 256000
  frame-relay bc 256000
  frame-relay be 0
!
map-class frame-relay police64K
  frame-relay cir 64000
  frame-relay bc 64000
  frame-relay be 64000

```

Example Congestion Management on Switched PVCs

The following example illustrates the configuration of congestion management and DE discard levels for all switched PVCs on serial interface 1. Policing is configured on PVC 16.

```

frame-relay switching
!
interface serial0
  encapsulation frame-relay
  frame-relay intf-type dce
  frame-relay policing
  frame-relay interface-dlci 16 switched
    class 256K
!

```

```

interface serial1
  encapsulation frame-relay
  frame-relay intf-type dce
  frame-relay congestion-management
    threshold ecn be 0
    threshold ecn bc 20
    threshold de 40
!
connect one serial1 100 serial0 16
!
map-class frame-relay 256K
  frame-relay cir 256000
  frame-relay bc 256000
  frame-relay be 256000

```

Example Congestion Management on the Traffic-Shaping Queue of a Switched PVC

The following example illustrates the configuration of congestion management in a class called "perpvc_congestion". The class is associated with the traffic-shaping queue of DLCI 200 on serial interface 3.

```

map-class frame-relay perpvc_congestion
  frame-relay holdq 100
  frame-relay congestion threshold ecn 50
interface Serial3
  frame-relay traffic-shaping
  frame-relay interface-dlci 200 switched
  class perpvc_congestion

```

Example FRF.12 Fragmentation on a Switched PVC Configuration

In the following example, FRF.12 fragmentation is configured in a map class called "data". The "data" map class is assigned to switched pvc 20 on serial interface 3/3.

```

frame-relay switching
!
interface Serial3/2
  encapsulation frame-relay
  frame-relay intf-type dce
!
interface Serial3/3
  encapsulation frame-relay
  frame-relay traffic-shaping
  frame-relay interface-dlci 20 switched
  class data
  frame-relay intf-type dce
!
map-class frame-relay data
  frame-relay fragment 80 switched
  frame-relay cir 64000
  frame-relay bc 640
!
connect data Serial3/2 16 Serial3/3 20

```

Example Frame Relay End-to-End Keepalive

- [Example End-to-End Keepalive Bidirectional Mode with Default Configuration, page 78](#)
- [Example End-to-End Keepalive Request Mode with Default Configuration, page 78](#)
- [Example End-to-End Keepalive Request Mode with Modified Configuration, page 78](#)

Example End-to-End Keepalive Bidirectional Mode with Default Configuration

In the following example, the devices at each end of a VC are configured so that a DLCI is assigned to a Frame Relay serial interface, a map class is associated with the interface, and Frame Relay end-to-end keepalive is configured in bidirectional mode using default values:

```
! router1
router1(config) interface serial 0/0.1 point-to-point
router1(config-if) ip address 10.1.1.1 255.255.255.0
router1(config-if) frame-relay interface-dlci 16
router1(config-if) frame-relay class vcgrp1
router1(config-if) exit
!
router1(config)# map-class frame-relay vcgrp1
router1(config-map-class)# frame-relay end-to-end keepalive mode bidirectional
! router2
router2(config) interface serial 1/1.1 point-to-point
router2(config-if) ip address 10.1.1.2 255.255.255.0
router2(config-if) frame-relay interface-dlci 16
router2(config-if) frame-relay class vceek
router1(config-if) exit
!
router2(config)# map-class frame-relay vceek
router2(config-map-class)# frame-relay end-to-end keepalive mode bidirectional
```

Example End-to-End Keepalive Request Mode with Default Configuration

In the following example, the devices at each end of a VC are configured so that a DLCI is assigned to a Frame Relay serial interface and a map class is associated with the interface. One device is configured in request mode while the other end of the VC is configured in reply mode.

```
! router1
router1(config) interface serial 0/0.1 point-to-point
router1(config-if) ip address 10.1.1.1 255.255.255.0
router1(config-if) frame-relay interface-dlci 16
router1(config-if) frame-relay class eek
router1(config-if) exit
!
router1(config)# map-class frame-relay eek
router1(config-map-class)# frame-relay end-to-end keepalive mode request
! router2
router2(config) interface serial 1/1.1 point-to-point
router2(config-if) ip address 10.1.1.2 255.255.255.0
router2(config-if) frame-relay interface-dlci 16
router2(config-if) frame-relay class group_3
router1(config-if) exit
!
router2(config)# map-class frame-relay group_3
router2(config-map-class)# frame-relay end-to-end keepalive mode reply
```

Example End-to-End Keepalive Request Mode with Modified Configuration

In the following example, the devices at each end of a VC are configured so that a DLCI is assigned to a Frame Relay serial interface and a map class is associated with the interface. One device is configured in request mode while the other end of the VC is configured in reply mode. The event window, error threshold, and success events values are changed so that the interface will change state less frequently:

```
! router1
router1(config) interface serial 0/0.1 point-to-point
router1(config-if) ip address 10.1.1.1 255.255.255.0
router1(config-if) frame-relay interface-dlci 16
router1(config-if) frame-relay class eek
```

```

router1(config-if) exit
!
router1(config)# map-class frame-relay eek
router1(config-map-class)# frame-relay end-to-end keepalive mode request
router1(config-map-class)# frame-relay end-to-end keepalive event-window send 5
router1(config-map-class)# frame-relay end-to-end keepalive error-threshold send 3
router1(config-map-class)# frame-relay end-to-end keepalive success-events send 3
!
router2
router2(config) interface serial 1/1.1 point-to-point
router2(config-if) ip address 10.1.1.2 255.255.255.0
router2(config-if) frame-relay interface-dlci 16
router2(config-if) frame-relay class group_3
router1(config-if) exit
!
router2(config)# map-class frame-relay group_3
router2(config-map-class)# frame-relay end-to-end keepalive mode reply

```

Example PPPoverFrameRelay

- [Example PPP over Frame Relay DTE, page 79](#)
- [Example PPP over Frame Relay DCE, page 79](#)

Example PPP over Frame Relay DTE

The following example configures a router as a DTE device for PPP over Frame Relay. Subinterface 2.1 contains the necessary DLCI and virtual template information. Interface Virtual-Template 1 contains the PPP information that is applied to the PPP session associated with DLCI 32 on serial subinterface 2.1.

```

interface serial 2
 no ip address
 encapsulation frame-relay
 frame-relay lmi-type ansi
!
interface serial 2.1 point-to-point
 frame-relay interface-dlci 32 ppp virtual-templatel
!
interface Virtual-Templatel
 ip unnumbered ethernet 0
 ppp authentication chap pap

```



Note

By default, the encapsulation type for a virtual template interface is PPP encapsulation; therefore, **encapsulation ppp** will not appear when you view the configuration of the router.

Example PPP over Frame Relay DCE

The following example configures a router to act as a DCE device. Typically, a router is configured as a DCE if it is connecting directly to another router or if connected to a 90i D4 channel unit, which is connected to a telco channel bank. The three commands required for this type of configuration are the **frame-relay switching**, **frame-relay intf-type dce**, and **frame-relay route** commands:

```

frame-relay switching
!
interface Serial2/0:0
 no ip address
 encapsulation frame-relay IETF
 frame-relay lmi-type ansi
 frame-relay intf-type dce
 frame-relay route 31 interface Serial1/2 100

```

```

frame-relay interface-dlci 32 ppp Virtual-Template1
!
interface Serial2/0:0.2 point-to-point
no ip address
frame-relay interface-dlci 40 ppp Virtual-Template2
!
interface Virtual-Template1
ip unnumbered Ethernet0/0
peer default ip address pool default
ppp authentication chap pap
!
interface Virtual-Template2
ip address 100.1.1.2 255.255.255.0
ppp authentication chap pap

```

**Note**

By default, the encapsulation type for a virtual template interface is PPP encapsulation; therefore, **encapsulation ppp** will not appear when you view the configuration of the router.

Example Frame Relay Fragmentation Configuration

- [Example FRF.12 Fragmentation, page 80](#)
- [Example Frame Relay Fragmentation with Hardware Compression, page 80](#)

Example FRF.12 Fragmentation

The following example shows the configuration of pure end-to-end FRF.12 fragmentation and weighted fair queuing in the map class called "frag". The fragment payload size is set to 40 bytes. The "frag" map class is associated with DLCI 100 on serial interface 1.

```

router(config)#
interface serial 1
router(config-if)# frame-relay traffic-shaping
router(config-if)# frame-relay interface-dlci 100
router(config-fr-dlci)# class frag
router(config-fr-dlci)# exit
router(config)#
map-class frame-relay frag
router(config-map-class)# frame-relay cir 128000
router(config-map-class)# frame-relay bc 1280
router(config-map-class)# frame-relay fragment 40
router(config-map-class)# frame-relay fair-queue

```

Example Frame Relay Fragmentation with Hardware Compression

In the following example, FRF.12 fragmentation and FRF.9 hardware compression are configured on multipoint interface 3/1 and point-to-point interface 3/1.1:

```

interface serial3/1
ip address 10.1.0.1 255.255.255.0
encapsulation frame-relay
frame-relay traffic-shaping
frame-relay class frag
frame-relay map ip 10.1.0.2 110 broadcast ietf payload-compression frf9 stac
!
interface serial3/1.1 point-to-point
ip address 10.2.0.1 255.255.255.0
frame-relay interface-dlci 120 ietf
frame-relay payload-compression frf9 stac
!
map-class frame-relay frag

```



```
frame-relay cir 64000
frame-relay bc 640
frame-relay fragment 100
```

Example Payload Compression Configuration



Note

Shut down the interface or subinterface prior to adding or changing compression techniques. Although shutdown is not required, shutting down the interface ensures that it is reset for the new data structures.

- [Example FRF.9 Compression for Subinterfaces Using the frame-relaymap Command, page 81](#)
- [Example FRF.9 Compression for Subinterfaces, page 81](#)
- [Example Data-Stream Hardware Compression with TCP IP Header Compression on a Point-to-Point Subinterface, page 81](#)
- [Example Data-Stream Hardware Compression with TCP IP Header Compression on a Multipoint Subinterface, page 82](#)
- [Example Data-Stream Hardware Compression with RTP Header Compression and Frame Relay Fragmentation, page 82](#)

Example FRF.9 Compression for Subinterfaces Using the frame-relaymap Command

The following example shows a subinterface being configured for FRF.9 compression using the **frame-relay map** command:

```
interface serial2/0/1
 ip address 172.16.1.4 255.255.255.0
 no ip route-cache
 encapsulation frame-relay IETF
 no keepalive
 frame-relay map ip 172.16.1.1 105 IETF payload-compression FRF9 stac
```

Example FRF.9 Compression for Subinterfaces

The following example shows a subinterface being configured for FRF.9 compression:

```
interface serial2/0/0
 no ip address
 no ip route-cache
 encapsulation frame-relay
 ip route-cache distributed
 no keepalive
 !
interface serial2/0/0.500 point-to-point
 ip address 172.16.1.4 255.255.255.0
 no cdp enable
 frame-relay interface-dlci 500 IETF
 frame-relay payload-compression FRF9 stac
```

Example Data-Stream Hardware Compression with TCP IP Header Compression on a Point-to-Point Subinterface

The following example shows the configuration of data-stream hardware compression and TCP header compression on point-to-point interface 1/0.1:

```
interface serial1/0
```

```

encapsulation frame-relay
frame-relay traffic-shaping
!
interface serial1/0.1 point-to-point
ip address 10.0.0.1 255.0.0.0
frame-relay interface-dlci 100
frame-relay payload-compression data-stream stac
frame-relay ip tcp header-compression

```

Example Data-Stream Hardware Compression with TCP IP Header Compression on a Multipoint Subinterface

The following example shows the configuration of data-stream hardware compression and TCP header compression on multipoint interface 3/1:

```

interface serial3/1
ip address 10.1.0.1 255.255.255.0
encapsulation frame-relay
frame-relay traffic-shaping
frame-relay map ip 10.1.0.2 110 broadcast cisco payload-compression data-stream stac
frame-relay ip tcp header-compression

```

Example Data-Stream Hardware Compression with RTP Header Compression and Frame Relay Fragmentation

The following example shows the configuration of data-stream hardware compression, RTP header compression, and FRF.12 fragmentation on point-to-point interface 1/0.1:

```

interface serial1/0
  encapsulation frame-relay
  frame-relay traffic-shaping
!
interface serial1/0.1 point-to-point
ip address 10.0.0.1 255.0.0.0
frame-relay interface-dlci 100
frame-relay class frag
frame-relay payload-compression data-stream stac
frame-relay ip rtp header-compression
!
map-class frame-relay frag
frame-relay cir 64000
frame-relay bc 640
frame-relay be 0
frame-relay fragment 100
frame-relay ip rtp priority 16000 16000 20

```

Example TCP IP Header Compression

- [Example IP Map with Inherited TCP IP Header Compression, page 82](#)
- [Example Using an IP Map to Override TCP IP Header Compression, page 83](#)
- [Example Disabling Inherited TCP IP Header Compression, page 83](#)
- [Example Disabling Explicit TCP IP Header Compression, page 84](#)

Example IP Map with Inherited TCP IP Header Compression

**Note**

Shut down the interface or subinterface prior to adding or changing compression techniques. Although shutdown is not required, shutting down the interface ensures that it is reset for the new data structures.

The following example shows an interface configured for TCP/IP header compression and an IP map that inherits the compression characteristics. Note that the Frame Relay IP map is not explicitly configured for header compression.

```
interface serial 1
 encapsulation frame-relay
 ip address 131.108.177.178 255.255.255.0
 frame-relay map ip 131.108.177.177 177 broadcast
 frame-relay ip tcp header-compression passive
```

Use of the **show frame-relay map** command will display the resulting compression and encapsulation characteristics; the IP map has inherited passive TCP/IP header compression:

```
Router> show frame-relay map
Serial 1 (administratively down): ip 131.108.177.177
      dlci 177 (0xB1,0x2C10), static,
      broadcast,
      CISCO
      TCP/IP Header Compression (inherited), passive (inherited)
```

This example also applies to dynamic mappings achieved with the use of Inverse ARP on point-to-point subinterfaces where no Frame Relay maps are configured.

Example Using an IP Map to Override TCP IP Header Compression

The following example shows the use of a Frame Relay IP map to override the compression set on the interface:

```
interface serial 1
 encapsulation frame-relay
 ip address 131.108.177.178 255.255.255.0
 frame-relay map ip 131.108.177.177 177 broadcast nocompress
 frame-relay ip tcp header-compression passive
```

Use of the **show frame-relay map** command will display the resulting compression and encapsulation characteristics; the IP map has not inherited TCP header compression:

```
Router> show frame-relay map
Serial 1 (administratively down): ip 131.108.177.177
      dlci 177 (0xB1,0x2C10), static,
      broadcast,
      CISCO
```

Example Disabling Inherited TCP IP Header Compression

In this example, following is the initial configuration:

```
interface serial 1
 encapsulation frame-relay
 ip address 131.108.177.179 255.255.255.0
 frame-relay ip tcp header-compression passive
 frame-relay map ip 131.108.177.177 177 broadcast
 frame-relay map ip 131.108.177.178 178 broadcast tcp header-compression
```

Enter the following commands to enable inherited TCP/IP header compression:

```
serial interface 1
 no frame-relay ip tcp header-compression
```

Use of the **show frame-relay map** command will display the resulting compression and encapsulation characteristics:

```
Router> show frame-relay map
Serial 1 (administratively down): ip 131.108.177.177 177
        dlci 177(0xB1, 0x2C10), static,
        broadcast
        CISCO
Serial 1 (administratively down): ip 131.108.177.178 178
        dlci 178(0xB2,0x2C20), static
        broadcast
        CISCO
        TCP/IP Header Compression (enabled)
```

As a result, header compression is disabled for the first map (with DLCI 177), which inherited its header compression characteristics from the interface. However, header compression is not disabled for the second map (DLCI 178), which is explicitly configured for header compression.

Example Disabling Explicit TCP IP Header Compression

In this example, the initial configuration is the same as in the preceding example, but you must enter the following set of commands to enable explicit TCP/IP header compression:

```
serial interface 1
no frame-relay ip tcp header-compression
frame-relay map ip 131.108.177.178 178 nocompress
```

Use of the **show frame-relay map** command will display the resulting compression and encapsulation characteristics:

```
Router> show frame-relay map
Serial 1 (administratively down): ip 131.108.177.177 177
        dlci 177(0xB1,0x2C10), static,
        broadcast
        CISCO
Serial 1 (administratively down): ip 131.108.177.178 178
        dlci 178(0xB2,0x2C20), static
        broadcast
        CISCO
```

The result of the commands is to disable header compression for the first map (with DLCI 177), which inherited its header compression characteristics from the interface, and also explicitly to disable header compression for the second map (with DLCI 178), which was explicitly configured for header compression.

Additional References

Related Documents

Related Topic	Document Title
Cisco IOS Wide-Area Networking configuration tasks	<i>Cisco IOS XE Wide-Area Networking Configuration Guide</i>
Wide-Area networking commands	<i>Cisco IOS Wide-Area Networking Command Reference</i>

Related Topic	Document Title
Sending DDR traffic over Frame Relay	<ul style="list-style-type: none"> Configuring Legacy DDR Spokes Configuring Legacy DDR Hubs
Installing software on a new router or access server by downloading from a central server over an interface that supports Frame Relay	Loading and Maintaining System Images
Using AutoInstall over Frame Relay	Overview - Basic Configuration of a Cisco Networking Device
Configuring transparent bridging between devices over a Frame Relay network	Configuring Transparent Bridging
Configuring source-route bridging between SNA devices over a Frame Relay network	Configuring Source-Route Bridging
Configuring serial tunnel (STUN) and block serial tunnel encapsulation between devices over a Frame Relay network	Configuring Serial Tunnel and Block Serial Tunnel
Configuring access between SNA devices over a Frame Relay network	Configuring SNA Frame Relay Access Support
Configuring Voice over Frame Relay Using FRF.11 and FRF.12	Configuring Voice over Frame Relay
Configuring low latency queueing, PVC interface priority queueing, and link fragmentation and interleaving using multilink PPP for Frame Relay	<i>Cisco IOS Quality of Service Solutions Configuration Guide</i>

Standards

Standard	Title
None	--

MIBs

MIB	MIBs Link
None	To locate and download MIBs for selected platforms, Cisco IOS XE software releases, and feature sets, use Cisco MIB Locator found at the following URL: http://www.cisco.com/go/mibs

RFCs

RFC	Title
None	--

Technical Assistance

Description	Link
<p>The Cisco Support website provides extensive online resources, including documentation and tools for troubleshooting and resolving technical issues with Cisco products and technologies.</p> <p>To receive security and technical information about your products, you can subscribe to various services, such as the Product Alert Tool (accessed from Field Notices), the Cisco Technical Services Newsletter, and Really Simple Syndication (RSS) Feeds.</p> <p>Access to most tools on the Cisco Support website requires a Cisco.com user ID and password.</p>	http://www.cisco.com/techsupport

Cisco and the Cisco Logo are trademarks of Cisco Systems, Inc. and/or its affiliates in the U.S. and other countries. A listing of Cisco's trademarks can be found at www.cisco.com/go/trademarks. Third party trademarks mentioned are the property of their respective owners. The use of the word partner does not imply a partnership relationship between Cisco and any other company. (1005R)

Any Internet Protocol (IP) addresses and phone numbers used in this document are not intended to be actual addresses and phone numbers. Any examples, command display output, network topology diagrams, and other figures included in the document are shown for illustrative purposes only. Any use of actual IP addresses or phone numbers in illustrative content is unintentional and coincidental.



Adaptive Frame Relay Traffic Shaping for Interface Congestion

Feature History

Release	Modification
12.2(4)T	This feature was introduced.

- [Finding Feature Information, page 87](#)
- [Feature Overview, page 87](#)
- [Supported Platforms, page 89](#)
- [Supported Standards and MIBs and RFCs, page 89](#)
- [Prerequisites, page 89](#)
- [Configuration Tasks, page 90](#)
- [Configuration Examples, page 92](#)
- [Glossary, page 92](#)

Finding Feature Information

Your software release may not support all the features documented in this module. For the latest feature information and caveats, see the release notes for your platform and software release. To find information about the features documented in this module, and to see a list of the releases in which each feature is supported, see the Feature Information Table at the end of this document.

Use Cisco Feature Navigator to find information about platform support and Cisco software image support. To access Cisco Feature Navigator, go to www.cisco.com/go/cfn. An account on Cisco.com is not required.

Feature Overview

The Adaptive Frame Relay Traffic Shaping for Interface Congestion feature enhances Frame Relay traffic shaping functionality by adjusting permanent virtual circuit (PVC) sending rates based on interface congestion. When this new feature is enabled, the traffic-shaping mechanism monitors interface congestion. When the congestion level exceeds a configured value called *queue depth*, the sending rate of all PVCs is reduced to the minimum committed information rate (minCIR). As soon as interface congestion drops below the queue depth, the traffic-shaping mechanism changes the sending rate of the PVCs back to the committed information rate (CIR). This process guarantees the minCIR for PVCs when there is interface congestion.

**Note**

The sum of the minCIR values for all PVCs on the interface must be less than the usable interface bandwidth.

This new feature works in conjunction with backward explicit congestion notification (BECN) and Foresight functionality. If interface congestion exceeds the queue depth when adaptive shaping for interface congestion is enabled along with BECN or ForeSight, then the PVC sending rate is reduced to the minCIR. When interface congestion drops below the queue depth, then the sending rate is adjusted in response to BECN or ForeSight.

Before the introduction of this feature, interface congestion caused packets to be delayed or dropped at the interface. The Adaptive Frame Relay Traffic Shaping for Interface Congestion feature helps ensure that packet drop occurs at the virtual circuit (VC) queues. When used with FRF.12 fragmentation, this feature also ensures that packets are dropped before fragmentation occurs.

- [Benefits, page 88](#)
- [Restrictions, page 88](#)
- [Related Features and Technologies, page 88](#)
- [Related Documents, page 88](#)

Benefits

The Adaptive Frame Relay Traffic Shaping for Interface Congestion feature:

- Guarantees minCIR for PVCs when there is interface congestion, as long as the sum of the minCIR values for the PVCs is less than the usable interface bandwidth.
- Increases the useful data rate by ensuring that packets are dropped before FRF.12 fragmentation.
- Enables intelligent packet drop by ensuring that packets are dropped at the VC queue rather than the interface.

Restrictions

This feature is supported on terminated and switched PVCs. It is not supported on switched virtual circuits (SVCs).

Related Features and Technologies

- Frame Relay traffic shaping

Related Documents

- *Cisco IOS Quality of Service Solutions Configuration Guide* , Release 12.2
- *Cisco IOS Quality of Service Solutions Command Reference* , Release 12.2
- *Cisco IOS Wide-Area Network Configuration Guide* , Release 12.2
- *Cisco IOS Wide-Area Network Command Reference* , Release 12.2

Supported Platforms

- Cisco 2500 series
- Cisco 2600 series
- Cisco 3600 series
- Cisco 7200 series

Platform Support Through Feature Navigator

Cisco IOS software is packaged in feature sets that support specific platforms. To get updated information regarding platform support for this feature, access Feature Navigator. Feature Navigator dynamically updates the list of supported platforms as new platform support is added for the feature.

Feature Navigator is a web-based tool that enables you to quickly determine which Cisco IOS software images support a specific set of features and which features are supported in a specific Cisco IOS image.

To access Feature Navigator, you must have an account on Cisco.com. If you have forgotten or lost your account information, send a blank e-mail to cco-locksmith@cisco.com. An automatic check will verify that your e-mail address is registered with Cisco.com. If the check is successful, account details with a new random password will be e-mailed to you.

Feature Navigator is updated when major Cisco IOS software releases and technology releases occur. As of May 2001, Feature Navigator supports M, T, E, S, and ST releases. You can access Feature Navigator at the following URL:

<http://www.cisco.com/go/fn>

Supported Standards and MIBs and RFCs

Standards

No new or modified standards are supported by this feature.

MIBs

No new or modified MIBs are supported by this feature.

To obtain lists of supported MIBs by platform and Cisco IOS release, and to download MIB modules, go to the Cisco MIB website on Cisco.com at the following URL:

<http://www.cisco.com/public/sw-center/netmgmt/cmtk/mibs.shtml>

RFCs

No new or modified RFCs are supported by this feature.

Prerequisites

In order to use the Adaptive Frame Relay Traffic Shaping for Interface Congestion feature, Frame Relay traffic shaping must be enabled on the interface.

Configuration Tasks

- [Configuring Frame Relay Adaptive Traffic Shaping, page 90](#)
- [Verifying Frame Relay Adaptive Traffic Shaping, page 90](#)

Configuring Frame Relay Adaptive Traffic Shaping

To configure a map class for adaptive traffic shaping for interface congestion, use the following commands beginning in global configuration mode:

SUMMARY STEPS

1. Router(config)# **map-class frame-relay** *map-class-name*
2. Router(config-map-class)# **frame-relay cir** {in | out} *bps*
3. Router(config-map-class)# **frame-relay mincir** {in | out} *bps*
4. Router(config-map-class)# **frame-relay adaptive-shaping interface-congestion** [*queue-depth*]

DETAILED STEPS

	Command or Action	Purpose
Step 1	Router(config)# map-class frame-relay <i>map-class-name</i>	Specifies a map class to define quality of service (QoS) values.
Step 2	Router(config-map-class)# frame-relay cir {in out} <i>bps</i>	(Optional) Specifies the incoming or outgoing CIR for a Frame Relay VC. The default is 56,000 bps.
Step 3	Router(config-map-class)# frame-relay mincir {in out} <i>bps</i>	(Optional) Specifies the minimum acceptable incoming or outgoing CIR for a Frame Relay VC. The default is CIR/2.
Step 4	Router(config-map-class)# frame-relay adaptive-shaping interface-congestion [<i>queue-depth</i>]	Enables adaptive traffic shaping for interface congestion and sets the queue depth.

Verifying Frame Relay Adaptive Traffic Shaping

SUMMARY STEPS

1. Use the **show frame-relay pvc** command to verify that Frame Relay adaptive traffic shaping for interface congestion is enabled. If it is enabled, the value IF_CONG will be displayed in the "Adaptive Shaping" field.
2. Use the **show interfaces serial** command to verify that Frame Relay adaptive traffic shaping for interface congestion is working correctly. If it is working correctly, the number of packets in the output queue will equal or be close to the queue depth value.

DETAILED STEPS

-
- Step 1** Use the **show frame-relay pvc** command to verify that Frame Relay adaptive traffic shaping for interface congestion is enabled. If it is enabled, the value IF_CONG will be displayed in the "Adaptive Shaping" field.

The following is sample output from the **show frame-relay pvc** command:

Example:

```
Router# show frame-relay pvc 41
PVC Statistics for interface Serial1 (Frame Relay DTE)
DLCI = 41, DLCI USAGE = LOCAL, PVC STATUS = DELETED, INTERFACE = Serial1.1
  input pkts 0          output pkts 0          in bytes 0
  out bytes 0          dropped pkts 0        in FECN pkts 0
  in BECN pkts 0       out FECN pkts 0       out BECN pkts 0
  in DE pkts 0         out DE pkts 0
  out bcast pkts 0     out bcast bytes 0
pvc create time 4d22h, last time pvc status changed 4d22h
cir 56000   bc 7000   be 0   byte limit 875   interval 125
mincir 28000   byte increment 875   Adaptive Shaping IF_CONG
pkts 0   bytes 0   pkts delayed 0   bytes delayed 0
shaping inactive
traffic shaping drops 0
Queueing strategy:fifo
Output queue 0/40, 0 drop, 0 dequeued
```

Step 2

Use the **show interfaces serial** command to verify that Frame Relay adaptive traffic shaping for interface congestion is working correctly. If it is working correctly, the number of packets in the output queue will equal or be close to the queue depth value.

Note The number of packets in the output queue changes between CIR and minCIR, so at a specific point in time the value may not equal the queue depth. However, the "average" number of packets in the output queue should equal the queue depth.

The following is sample output from the **show interfaces serial** command for an interface that is configured with adaptive traffic shaping for interface congestion with a queue depth of 10 packets. The "Output queue" field indicates 10 packets in the interface queue.

Router# **show interfaces serial 2**

Example:

```
Serial2 is up, line protocol is up
Hardware is HD64570
Internet address is 2.0.0.2/8
MTU 1500 bytes, BW 1544 Kbit, DLY 20000 usec,
  reliability 255/255, txload 10/255, rxload 10/255
Encapsulation FRAME-RELAY, loopback not set
Keepalive not set
FR SVC disabled, LAPF state down
Broadcast queue 0/64, broadcasts sent/dropped 0/0, interface broadcasts 0
Last input 00:06:55, output 00:00:00, output hang never
Last clearing of "show interface" counters 00:11:01
Queueing strategy:fifo
Output queue 10/40, 6731 drops; input queue 24/75, 0 drops
.
.
.
```

Note For a description of each output display field, refer to the **show interfaces serial** command reference page in the *Cisco IOS Interface Command Reference* .

Configuration Examples

- [Example Frame Relay Adaptive Traffic Shaping for Interface Congestion, page 92](#)

Example Frame Relay Adaptive Traffic Shaping for Interface Congestion

In the following example, the rate of traffic destined for PVC 200 will be reduced to the minCIR if the number of packets in the interface queue exceeds 10. When the number of packets in the interface queue drops below 10, then the traffic rate will immediately return to the CIR.

```
interface serial0
 encapsulation frame-relay
 frame-relay traffic-shaping
 frame-relay interface-dlci 200
 class adjust_vc_class_rate
 !
 map-class frame-relay adjust_vc_class_rate
 frame-relay cir 64000
 frame-relay mincir 32000
 frame-relay adaptive-shaping interface-congestion 10
```

Glossary

BECN --backward explicit congestion notification. Bit set by a Frame Relay network in frames traveling in the opposite direction of frames encountering a congested path. DTE receiving frames with the BECN bit set can request that higher-level protocols take flow control action as appropriate.

CIR --committed information rate. The rate at which a Frame Relay network agrees to transfer information under normal conditions, averaged over a minimum increment of time. CIR, measured in bits per second, is one of the key negotiated traffic metrics.

ForeSight --A network traffic control feature used in Cisco switches. When the ForeSight feature is enabled on the switch, the switch will periodically send out a ForeSight message. When a Cisco router receives a ForeSight message indicating that certain data-link connection identifiers (DLCIs) are experiencing congestion, the router reacts by activating its traffic-shaping function to slow down the output rate.

FRF.12 --An implementation agreement developed to allow long data frames to be fragmented into smaller pieces and interleaved with real-time frames. In this way, real-time voice and nonreal-time data frames can be carried together on lower-speed links without causing excessive delay to the real-time traffic.

minCIR --The minimum acceptable incoming or outgoing committed information rate (CIR) for a Frame Relay virtual circuit.

PVC --permanent virtual circuit or connection. A virtual circuit that is permanently established. PVCs save bandwidth associated with circuit establishment and teardown in situations where certain virtual circuits must exist all the time.

SVC --switched virtual circuit. Virtual circuit that is dynamically established on demand and is torn down when transmission is complete. SVCs are used in situations where data transmission is sporadic.

CCVP, the Cisco logo, and Welcome to the Human Network are trademarks of Cisco Systems, Inc.; Changing the Way We Work, Live, Play, and Learn is a service mark of Cisco Systems, Inc.; and Access Registrar, Aironet, Catalyst, CCDA, CCDP, CCIE, CCIP, CCNA, CCNP, CCSR, Cisco, the Cisco Certified Internetwork Expert logo, Cisco IOS, Cisco Press, Cisco Systems, Cisco Systems Capital, the Cisco Systems logo, Cisco Unity, Enterprise/Solver, EtherChannel, EtherFast, EtherSwitch, Fast Step, Follow Me Browsing, FormShare, GigaDrive, HomeLink, Internet Quotient, IOS, iPhone, IP/TV, IQ Expertise, the IQ logo, IQ Net Readiness Scorecard, iQuick Study, LightStream, Linksys, MeetingPlace, MGX, Networkers, Networking Academy, Network Registrar, PIX, ProConnect, ScriptShare, SMARTnet, StackWise, The Fastest Way to Increase Your Internet Quotient, and TransPath are registered trademarks of Cisco Systems, Inc. and/or its affiliates in the United States and certain other countries.

All other trademarks mentioned in this document or Website are the property of their respective owners. The use of the word partner does not imply a partnership relationship between Cisco and any other company. (0711R)

Cisco and the Cisco Logo are trademarks of Cisco Systems, Inc. and/or its affiliates in the U.S. and other countries. A listing of Cisco's trademarks can be found at www.cisco.com/go/trademarks. Third party trademarks mentioned are the property of their respective owners. The use of the word partner does not imply a partnership relationship between Cisco and any other company. (1005R)

Any Internet Protocol (IP) addresses and phone numbers used in this document are not intended to be actual addresses and phone numbers. Any examples, command display output, network topology diagrams, and other figures included in the document are shown for illustrative purposes only. Any use of actual IP addresses or phone numbers in illustrative content is unintentional and coincidental.



Frame Relay 64-Bit Counters

Feature History

Release	Modification
12.0(17)S	This feature was introduced on the Cisco 12000 series.
12.2(4)T	This feature was integrated into Cisco IOS Release 12.2(4)T.
12.2(4)T3	Support for the Cisco 7500 series routers was added.
12.0(21)S	The frame-relay ifmib-counter64 command was introduced.
12.3(10)	The frame-relay ifmib-counter64 command was integrated into Cisco IOS Release 12.3(10).
12.3(11)T	The frame-relay ifmib-counter64 command was integrated into Cisco IOS Release 12.3(11)T.
12.2(18)SXE	The frame-relay ifmib-counter64 command was integrated into Cisco IOS Release 12.2(18)SXE.

- [Finding Feature Information, page 95](#)
- [Feature Overview, page 96](#)
- [Supported Platforms, page 96](#)
- [Supported Standards and MIBs and RFCs, page 97](#)
- [Prerequisites, page 97](#)
- [Configuration Tasks, page 97](#)
- [Monitoring and Maintaining Frame Relay 64-Bit Counters, page 98](#)
- [Configuration Examples, page 99](#)

Finding Feature Information

Your software release may not support all the features documented in this module. For the latest feature information and caveats, see the release notes for your platform and software release. To find information about the features documented in this module, and to see a list of the releases in which each feature is supported, see the Feature Information Table at the end of this document.

Use Cisco Feature Navigator to find information about platform support and Cisco software image support. To access Cisco Feature Navigator, go to www.cisco.com/go/cfn. An account on Cisco.com is not required.

Feature Overview

The Frame Relay 64-Bit Counters feature provides 64-bit counter support on Frame Relay interfaces and subinterfaces. This feature enables the gathering of statistics through Simple Network Management Protocol (SNMP) for faster interfaces operating at OC-3, OC-12, and OC-48 speeds.

The following counters are supported by this feature: Bytes In, Bytes Out, Packets In, and Packets Out.

The **show frame-relay pvc** command has been modified to display the 64-bit counters.

- [Benefits, page 96](#)
- [Restrictions, page 96](#)
- [Related Documents, page 96](#)

Benefits

The values in 32-bit counters sometime wrap because the field is too small. Wrapping causes the values in these fields to become meaningless. The 64-bit counters support the reliable gathering of statistics by SNMP by preventing the wrapping of counter values.

Restrictions

SNMP cannot retrieve 64-bit virtual-circuit (VC) counters.

Related Documents

For information on configuring Frame Relay using Cisco IOS software, refer to the following documents:

- The chapter "Configuring Frame Relay" in the *Cisco IOS Wide-Area Networking Configuration Guide*, Release 12.2
- The chapter "Frame Relay Commands" in the *Cisco IOS Wide-Area Networking Command Reference*, Release 12.2

For information on configuring SNMP using Cisco IOS software, see the following documents:

- The chapter "Configuring Simple Network Management Protocol" in the *Cisco IOS Configuration Fundamentals Configuration Guide*, Release 12.2
- The chapter "SNMP Commands" in the *Cisco IOS Configuration Fundamentals Command Reference*, Release 12.2

Supported Platforms

- Cisco 7200 series
- Cisco 7500 series (Cisco IOS Release 12.2(4)T3 and later)

Platform Support Through Feature Navigator

Cisco IOS software is packaged in feature sets that support specific platforms. To get updated information regarding platform support for this feature, access Feature Navigator. Feature Navigator dynamically updates the list of supported platforms as new platform support is added for the feature.

Feature Navigator is a web-based tool that enables you to quickly determine which Cisco IOS software images support a specific set of features and which features are supported in a specific Cisco IOS image.

To access Feature Navigator, you must have an account on Cisco.com. If you have forgotten or lost your account information, send a blank e-mail to cco-locksmith@cisco.com. An automatic check will verify that your e-mail address is registered with Cisco.com. If the check is successful, account details with a new random password will be e-mailed to you. Qualified users can establish an account on Cisco.com by following the directions at <http://www.cisco.com/register>.

Feature Navigator is updated when major Cisco IOS software releases and technology releases occur. As of May 2001, Feature Navigator supports M, T, E, S, and ST releases. You can access Feature Navigator at the following URL:

<http://www.cisco.com/go/fn>

Supported Standards and MIBs and RFCs

Standards

No new or modified standards are supported by this feature.

MIBs

The **frame-relay ifmib-counter64** command modifies the interface MIB (IF-MIB) by allowing slower Frame Relay interfaces and subinterfaces to be included in the 64-bit interface MIB counters.

To obtain lists of supported MIBs by platform and Cisco IOS release, and to download MIB modules, go to the Cisco MIB website on Cisco.com at the following URL:

<http://www.cisco.com/public/sw-center/netmgmt/cmtk/mibs.shtml>

RFCs

No new or modified RFCs are supported by this feature.

Prerequisites

This document assumes that you know how to configure Frame Relay and SNMP support using Cisco IOS software.

Configuration Tasks

- [Enabling Frame Relay Interfaces for 64-Bit Interface MIB Counters](#), page 98

Enabling Frame Relay Interfaces for 64-Bit Interface MIB Counters



Note

This task is supported in Cisco IOS releases 12.0(21)S, 12.3(10), 12.3(11)T, 12.2(18)SXE, and later releases.

Frame Relay interfaces and subinterfaces that have a line speed greater than 20 Mbps are included in the 64-bit interface MIB counters by default. Perform this task to enable Frame Relay interfaces and subinterfaces that have a line speed of less than 20 Mbps to be included in the 64-bit interface MIB counters.

SUMMARY STEPS

1. Router> **enable**
2. Router# **configure terminal**
3. Router(config)# **interface serial** *interface-number*
4. Router(config-if)# **encapsulation frame-relay**
5. Router(config-if)# **frame-relay ifmib-counter64** [*if* | *subif*]

DETAILED STEPS

	Command or Action	Purpose
Step 1	Router> enable	Enables privileged EXEC mode. <ul style="list-style-type: none"> • Enter your password if prompted.
Step 2	Router# configure terminal	Enters global configuration mode.
Step 3	Router(config)# interface serial <i>interface-number</i>	Specifies an interface to be configured and enters interface configuration mode.
Step 4	Router(config-if)# encapsulation frame-relay	Enables Frame Relay encapsulation.
Step 5	Router(config-if)# frame-relay ifmib-counter64 [<i>if</i> <i>subif</i>]	Enables Frame Relay interfaces and subinterfaces that have a line speed of less than 20 Mbps to be included in 64-bit interface MIB counters. <ul style="list-style-type: none"> • This command allows Frame Relay interfaces and subinterfaces that have a line speed of less than 20 Mbps to be included in the following 64-bit interface MIB counters: <ul style="list-style-type: none"> ◦ ifHCinOctets ◦ ifHCOctets ◦ ifHCinUcastPkts ◦ ifHCOctetsUcastPkts

Monitoring and Maintaining Frame Relay 64-Bit Counters

To view the values of the Frame Relay 64-bit counters, use the following command in EXEC mode:

Command	Purpose
<pre>Router# show frame-relay pvc 64-bit [interface interface] [dlci]</pre>	Displays statistics about permanent virtual circuits (PVCs) for Frame Relay interfaces.

Configuration Examples

- [Enabling Slower Frame Relay Interfaces and Subinterfaces for 64-Bit Interface MIB Counters Example, page 99](#)
- [Enabling Only Slower Frame Relay Subinterfaces for 64-Bit Interface MIB Counters Example, page 100](#)

Enabling Slower Frame Relay Interfaces and Subinterfaces for 64-Bit Interface MIB Counters Example

In the following example, the **frame-relay ifmib-counter64** command is used with the **if** keyword to enable serial interfaces 6/0/1:0, 6/0/2:0, and 6/0/3:0 and related subinterfaces to be included in the 64-bit interface MIB counters. The example also shows corresponding output for the **show frame-relay pvc** command and the corresponding statistics for the 64-bit interface MIB counters.

```
interface Serial6/0/1:0
 ip address 1.1.1.1 255.255.255.0
 encapsulation frame-relay
 no ip route-cache cef
 no ip route-cache
 frame-relay interface-dlci 101
 no frame-relay inverse-arp
 frame-relay ifmib-counter64 if
interface Serial6/0/2:0
 no ip address
 encapsulation frame-relay
 no ip route-cache cef
 no ip route-cache
 no frame-relay inverse-arp
 frame-relay ifmib-counter64 if
!
interface Serial6/0/2:0.1 point-to-point
 ip address 2.1.1.1 255.255.255.0
 no ip route-cache
 frame-relay interface-dlci 201
!
interface Serial6/0/3:0
 ip address 3.1.1.1 255.255.255.0
 encapsulation frame-relay
 frame-relay interface-dlci 301
 no frame-relay inverse-arp
 frame-relay ifmib-counter64 if
interface Serial6/0/3:0.1 point-to-point
 ip address 3.1.2.1 255.255.255.0
 frame-relay interface-dlci 302
```

The following example shows corresponding sample output for the **show frame-relay pvc** command with the **64-bit** keyword. Note that the **frame-relay ifmib-counter64** command does not affect the output of the **show frame-relay pvc** command.

```
Router# show frame-relay pvc 101 64-bit
DLCI = 101, INTERFACE = Serial6/0/1:0
  input pkts 231          output pkts 228
  in bytes 23604         out bytes 23502
Router#
Router# show frame-relay pvc 201 64-bit

DLCI = 201, INTERFACE = Serial6/0/2:0.1
  input pkts 1453        output pkts 1408
  in bytes 335024       out bytes 327272
Router#
Router# show frame-relay pvc 301 64-bit
DLCI = 301, INTERFACE = Serial6/0/3:0
  input pkts 510         output pkts 508
  in bytes 52690        out bytes 52622
Router#
Router# show frame-relay pvc 302 64-bit
DLCI = 302, INTERFACE = Serial6/0/3:0.1
  input pkts 957         output pkts 912
  in bytes 283246       out bytes 275493
Router#
```

The following output from an SNMP inquiry shows that the 64-bit interface MIB counters include the interfaces configured above:

```
ifHCInOctets.5 = 0x000000000
ifHCInOctets.16 = 0x000000000
ifHCInOctets.17 = 0x003360d33
ifHCInOctets.18 = 0x000000000
ifHCInOctets.19 = 0x000000000
ifHCInOctets.20 = 0x000000000
ifHCInOctets.24 = 0x000000000
ifHCInOctets.25 = 0x000000000
ifHCInOctets.26 = 0x0001a7afc !! This is serial interface 6/0/1:0
ifHCInOctets.28 = 0x0001a7370 !! This is serial interface 6/0/2:0
ifHCInOctets.34 = 0x00006a45a !! This is serial interface 6/0/3:0
ifHCInOctets.36 = 0x000051cb0 !! This is serial subinterface 6/0/2:0.1
ifHCInOctets.37 = 0x00004526e !! This is serial subinterface 6/0/3:0.1
```

Enabling Only Slower Frame Relay Subinterfaces for 64-Bit Interface MIB Counters Example

In the following example, the **frame-relay ifmib-counter64** command is used with the **subif** keyword to enable subinterfaces that are associated with serial interfaces 6/0/1:0, 6/0/2:0, and 6/0/3:0 to be included in the 64-bit interface MIB counters. Slower main interfaces are not included. The example also shows the corresponding statistics for the 64-bit interface MIB counters.

```
interface Serial6/0/1:0
 ip address 1.1.1.1 255.255.255.0
 encapsulation frame-relay
 no ip route-cache cef
 no ip route-cache
 frame-relay interface-dlci 101
 no frame-relay inverse-arp
 frame-relay ifmib-counter64 subif
interface Serial6/0/2:0
 no ip address
 encapsulation frame-relay
 no ip route-cache cef
 no ip route-cache
 no frame-relay inverse-arp
```

```

frame-relay ifmib-counter64 subif
interface Serial6/0/2:0.1 point-to-point
ip address 2.1.1.1 255.255.255.0
no ip route-cache
frame-relay interface-dlci 201
!
interface Serial6/0/3:0
ip address 3.1.1.1 255.255.255.0
encapsulation frame-relay
frame-relay interface-dlci 301
no frame-relay inverse-arp
frame-relay ifmib-counter64 subif
interface Serial6/0/3:0.1 point-to-point
ip address 3.1.2.1 255.255.255.0
frame-relay interface-dlci 302

```

The following example shows corresponding sample output for the **show frame-relay pvc** command with the **64-bit** keyword. Note that the **frame-relay ifmib-counter64** command does not affect the output of the **show frame-relay pvc** command.

```

Router# show frame-relay pvc 101 64-bit
DLCI = 101, INTERFACE = Serial6/0/1:0
  input pkts 231                output pkts 228
  in bytes 23604                out bytes 23502
Router#
Router# show frame-relay pvc 201 64-bit
DLCI = 201, INTERFACE = Serial6/0/2:0.1
  input pkts 1453               output pkts 1408
  in bytes 335024              out bytes 327272
Router#
Router# show frame-relay pvc 301 64-bit
DLCI = 301, INTERFACE = Serial6/0/3:0
  input pkts 510                output pkts 508
  in bytes 52690               out bytes 52622
Router#
Router# show frame-relay pvc 302 64-bit
DLCI = 302, INTERFACE = Serial6/0/3:0.1
  input pkts 957                output pkts 912
  in bytes 283246              out bytes 275493

```

The following output from an SNMP inquiry shows that the 64-bit interface MIB counters include the subinterfaces configured above:

```

ifHCInOctets.5 = 0x000000000
ifHCInOctets.16 = 0x000000000
ifHCInOctets.17 = 0x00337a158
ifHCInOctets.18 = 0x000000000
ifHCInOctets.19 = 0x000000000
ifHCInOctets.20 = 0x000000000
ifHCInOctets.24 = 0x000000000
ifHCInOctets.25 = 0x000000000
ifHCInOctets.36 = 0x000051cb0 !! This is serial subinterface 6/0/2:0.1
ifHCInOctets.37 = 0x00004526e !! This is serial subinterface 6/0/3:0.1

```

Cisco and the Cisco Logo are trademarks of Cisco Systems, Inc. and/or its affiliates in the U.S. and other countries. A listing of Cisco's trademarks can be found at www.cisco.com/go/trademarks. Third party trademarks mentioned are the property of their respective owners. The use of the word partner does not imply a partnership relationship between Cisco and any other company. (1005R)

Any Internet Protocol (IP) addresses and phone numbers used in this document are not intended to be actual addresses and phone numbers. Any examples, command display output, network topology diagrams,

and other figures included in the document are shown for illustrative purposes only. Any use of actual IP addresses or phone numbers in illustrative content is unintentional and coincidental.



Frame Relay MIB Enhancements

The Cisco Frame Relay MIB describes managed objects that enable users to remotely monitor Frame Relay operations using Simple Network Management Protocol (SNMP). Frame Relay fragmentation is supported in the MIB.

- [Finding Feature Information, page 103](#)
- [Prerequisites for Frame Relay MIB Enhancements, page 103](#)
- [Information About Frame Relay MIB Enhancements, page 103](#)
- [Supported Platforms, page 105](#)
- [Supported Standards and MIBs and RFCs, page 105](#)
- [How to Configure Frame Relay MIB Enhancements, page 106](#)
- [Configuration Examples for Frame Relay MIB Enhancements, page 106](#)
- [Feature Information for Frame Relay MIB Enhancements, page 107](#)

Finding Feature Information

Your software release may not support all the features documented in this module. For the latest feature information and caveats, see the release notes for your platform and software release. To find information about the features documented in this module, and to see a list of the releases in which each feature is supported, see the Feature Information Table at the end of this document.

Use Cisco Feature Navigator to find information about platform support and Cisco software image support. To access Cisco Feature Navigator, go to www.cisco.com/go/cfn. An account on Cisco.com is not required.

Prerequisites for Frame Relay MIB Enhancements

The tasks in this document assume that you have configured Frame Relay and SNMP on your devices.

To access the information introduced by the Frame Relay MIB enhancements, you must have the Cisco Frame Relay MIB in the MIB file called CISCO-FRAME-RELAY-MIB.my compiled in your network management system (NMS) application. You can find this MIB on the Web at Cisco's MIB website at

<http://www.cisco.com/public/sw-center/netmgmt/cmtk/mibs.shtml>

Information About Frame Relay MIB Enhancements

- [Feature Overview, page 104](#)
- [Benefits, page 105](#)

- [Related Documents, page 105](#)

Feature Overview

The Cisco Frame Relay MIB describes managed objects that enable users to remotely monitor Frame Relay operations using Simple Network Management Protocol (SNMP). The Frame Relay MIB Enhancements feature extends the Cisco Frame Relay MIB by adding MIB objects to monitor the following Frame Relay functionality:

- Frame Relay fragmentation
- Frame Relay-ATM Network Interworking (FRF.5)
- Frame Relay-ATM Service Interworking (FRF.8)
- Frame Relay switching
- Input and output rates of individual virtual circuits (VCs)

The table below describes the MIB tables and objects that are introduced by the Frame Relay MIB enhancements. For a complete description of the MIB, see the Cisco Frame Relay MIB file CISCO-FRAME-RELAY-MIB.my, available through Cisco.com at the following URL:

<http://www.cisco.com/public/sw-center/netmgmt/cmtk/mibs.shtml>

Table 2 **MIB Tables and Objects Introduced by the Frame Relay MIB Enhancements**

Table or Object	Description
cfrFragTable	Table of Frame Relay fragmentation information.
cfrFRF5ConnectionTable	Table of Frame Relay-ATM Network Interworking connection information.
cfrFRF8ConnectionTable	Table of Frame Relay-ATM Service Interworking connection information.
cfrSwitchingTable	Table of Frame Relay switching entries.
cfrExtCircuitTxDataRate	Average rate, in bytes per second, at which data is transmitted on a circuit.
cfrExtCircuitTxPktRate	Average number of packets sent per second on a circuit.
cfrExtCircuitRcvDataRate	Average rate, in bytes per second, at which data is received on a circuit.
cfrExtCircuitRcvPktRate	Average number of packets received per second on a circuit.

The Frame Relay MIB Enhancements feature also modifies the **load-interval** command to enable you to configure the load interval per permanent virtual circuit (PVC). The load interval is the length of time for which data is used to compute load statistics, including input rate in bits and packets per second, output rate in bits and packets per second, load, and reliability. Before the introduction of this feature, the load interval could be configured only for the interface.

Benefits

The Frame Relay MIB Enhancements enable you to use SNMP to monitor the following:

- Frame Relay fragmentation
- Frame Relay-ATM Network Interworking (FRF.5)
- Frame Relay-ATM Service Interworking (FRF.8)
- Frame Relay switching
- Input and output rates of individual virtual circuits (VCs)

Related Documents

For information on configuring Frame Relay using Cisco IOS software, refer to the following documents:

- The chapter "Configuring Frame Relay" in the *Cisco IOS Wide-Area Networking Configuration Guide*, Release 12.2
- The chapter "Frame Relay Commands" in the *Cisco IOS Wide-Area Networking Command Reference*, Release 12.2

For information on configuring SNMP using Cisco IOS software, refer to the following documents:

- The chapter "Configuring Simple Network Management Protocol" in the *Cisco IOS Configuration Fundamentals Configuration Guide*, Release 12.2
- The chapter "SNMP Commands" in the *Cisco IOS Configuration Fundamentals Command Reference*, Release 12.2

Supported Platforms

- This MIB feature is platform independent, and is supported on all images that support Frame Relay and SNMP.

Determining Platform Support Through Feature Navigator

MIB introductions and updates are not tracked through Feature Navigator. Instead, use the MIB Locator tool at <http://www.cisco.com/go/mibs>.

Supported Standards and MIBs and RFCs

Standards

No new or modified standards are supported by this feature.

MIBs

This feature provides enhancements to the Cisco Frame Relay MIB. The MIB file CISCO-FRAME-RELAY-MIB.my can be downloaded from the Cisco MIB website on Cisco.com at the following URL:

<http://www.cisco.com/public/sw-center/netmgmt/cmtk/mibs.shtml>

To obtain lists of supported MIBs by platform and Cisco IOS release, and to download MIB modules, go to the Cisco MIB website on Cisco.com at the following URL:

<http://www.cisco.com/public/sw-center/netmgmt/cmtk/mibs.shtml>

RFCs

No new or modified RFCs are supported by this feature.

How to Configure Frame Relay MIB Enhancements

- [Setting the Load Interval for a PVC, page 106](#)
- [Verifying the Load Interval, page 106](#)

Setting the Load Interval for a PVC

You can change the period of time over which a set of data is used for computing load statistics. Decisions, such as for dial backup, depend on these statistics. If you decrease the load interval, the average statistics are computed over a shorter period of time and are more responsive to bursts of traffic.

To change the length of time for which a set of data is used to compute load statistics for a PVC, use the following commands beginning in interface configuration mode:

SUMMARY STEPS

1. Router(config-if)# **frame-relay interface-dlci** *dlci*
2. router(config-fr-dlci)# **load-interval** *seconds*

DETAILED STEPS

	Command or Action	Purpose
Step 1	Router(config-if)# frame-relay interface-dlci <i>dlci</i>	Assigns a specific PVC to a DLCI ³ , and enters Frame Relay DLCI configuration mode.
Step 2	router(config-fr-dlci)# load-interval <i>seconds</i>	Changes the length of time for which data is used to compute load statistics. The seconds argument must be a multiple of 30. The range is from 30 to 300 seconds. The default is 300 seconds.

Verifying the Load Interval

Use the **show running-config** command to verify that you have configured the load interval correctly.

Configuration Examples for Frame Relay MIB Enhancements

- [Example Setting the Load Interval for a PVC, page 107](#)

³ DLCI = data-link connection identifier

Example Setting the Load Interval for a PVC

In the following example, the load interval is set to 60 seconds for a Frame Relay PVC with the DLCI 100:

```
interface serial 1/1
 frame-relay interface-dlci 100
 load-interval 60
```

Feature Information for Frame Relay MIB Enhancements

The following table provides release information about the feature or features described in this module. This table lists only the software release that introduced support for a given feature in a given software release train. Unless noted otherwise, subsequent releases of that software release train also support that feature.

Use Cisco Feature Navigator to find information about platform support and Cisco software image support. To access Cisco Feature Navigator, go to www.cisco.com/go/cfn. An account on Cisco.com is not required.

Table 3 Feature Information for Frame Relay MIB Enhancements

Feature Name	Releases	Feature Information
Frame Relay MIB Enhancements	12.2(2)T	The Cisco Frame Relay MIB describes managed objects that enable users to remotely monitor Frame Relay operations using SNMP.

Cisco and the Cisco Logo are trademarks of Cisco Systems, Inc. and/or its affiliates in the U.S. and other countries. A listing of Cisco's trademarks can be found at www.cisco.com/go/trademarks. Third party trademarks mentioned are the property of their respective owners. The use of the word partner does not imply a partnership relationship between Cisco and any other company. (1005R)

Any Internet Protocol (IP) addresses and phone numbers used in this document are not intended to be actual addresses and phone numbers. Any examples, command display output, network topology diagrams, and other figures included in the document are shown for illustrative purposes only. Any use of actual IP addresses or phone numbers in illustrative content is unintentional and coincidental.



Frame Relay Point-Multipoint Wireless

Feature History

Release	Modification
Prior to 12.2(2)T	This feature was introduced on various platforms.
12.2(2)T	Support for this feature was added to multipoint fixed wireless.

This feature module describes Frame Relay support for multipoint fixed wireless. It includes information on the benefits of the new feature, supported platforms, related documents, and other information.

- [Finding Feature Information, page 109](#)
- [Feature Overview, page 109](#)
- [Supported Platforms, page 111](#)
- [Supported Standards and MIBs and RFCs, page 111](#)
- [Prerequisites, page 112](#)
- [Configuration Tasks, page 112](#)
- [Configuration Examples, page 113](#)

Finding Feature Information

Your software release may not support all the features documented in this module. For the latest feature information and caveats, see the release notes for your platform and software release. To find information about the features documented in this module, and to see a list of the releases in which each feature is supported, see the Feature Information Table at the end of this document.

Use Cisco Feature Navigator to find information about platform support and Cisco software image support. To access Cisco Feature Navigator, go to www.cisco.com/go/cfn. An account on Cisco.com is not required.

Feature Overview

This feature provides an end-to-end Frame Relay network for customers using wireless interfaces in their Frame Relay network. Several new commands are used to establish a virtual Frame Relay interface, then link it to a specific multipoint destination MAC address. The configuration information is associated with a new interface type, virtual Frame Relay and new interface commands, **interface virtual-framerelay** and **frame-relay over radio**.

Using the new interface enables Cisco uBR7200 series, Cisco 3600 series, and Cisco 2600 series routers to provide a seamless transition from a serial interface to a multipoint Frame Relay interface. By

implementing RFC 1315, Frame Relay DTE MIB, a virtual Frame Relay interface can be linked to a specific multipoint radio interface and destination MAC address. The headend router acts as a Frame Relay switch, receiving radio frequency signals from subscriber units. Once received, the multipoint link is switched to a serial link and then to an upstream router.

Figure 14 Point to Multipoint

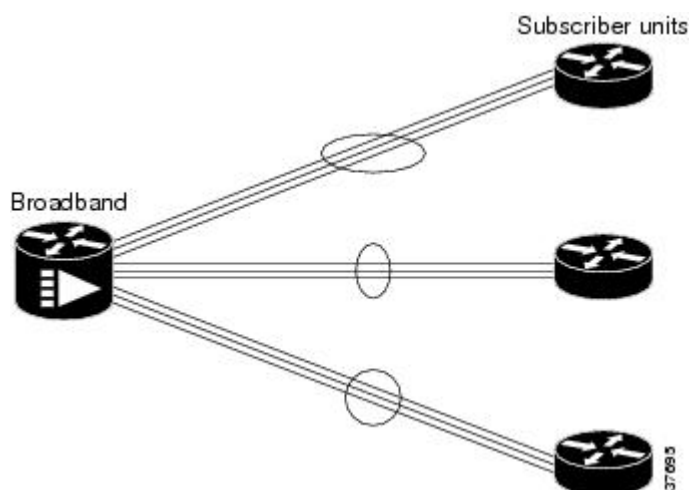

- [Benefits, page 110](#)
- [Restrictions, page 110](#)
- [Related Features and Technologies, page 110](#)
- [Related Documents, page 111](#)

Benefits

This feature provides a seamless extension of Frame Relay services over fixed wireless. The look and feel of the interface is consistent with existing Frame Relay services.

The existing Frame Relay infrastructure is leveraged by creating a virtual interface. No hardware upgrade is required.

Restrictions

The wireless network module must be installed and configured correctly and use the Cisco IOS Release 12.2(2)T image. The virtual Frame Relay interface is used only in conjunction with the multipoint radio interface. It cannot be used in conjunction with the cable interface.

Frame Relay over fixed wireless offers a lower payload than over a serial interface. The payload is 1488 bytes compared to 1500 bytes when Frame Relay is on a serial link.

Related Features and Technologies

The multipoint fixed wireless interface must be used to take advantage of the new functionality.

Related Documents

For detailed information about Cisco multipoint wireless support on the Cisco uBR7200 series universal broadband routers, and the Cisco 2600 series and Cisco 3600 series routers, see the following documents:

Routers

- *Router Products Command Reference*

Headend Documents

- *Cisco uBR7200 Series Multipoint Wireless Modem Card and Subsystem Installation*
- *Cisco Multipoint Headend Wireless Transverter Duplexer Replacement Instructions*
- *Cisco Multipoint Headend Power Feed Panel Replacement Instructions*
- *Cisco Multipoint Headend Wireless Transverter Replacement Instructions*
- *Multipoint Wireless Support for Cisco uBR7200 Series Universal Broadband Router*

Subscriber Unit Documents

- *Multipoint Wireless Support for the Cisco 2600 and Cisco 3600 Series Routers*
- *Cisco 2600 Series Hardware Installation Guide*
- *Software Configuration Guide (for Cisco 3600 series and Cisco 2600 series routers)*
- *Cisco Network Modules Hardware Installation Guide (for Cisco 3600 series and Cisco 2600 series routers)*

Supported Platforms

The Frame Relay Point-Multipoint Wireless feature is supported on following platforms:

- Cisco 2610
- Cisco 2611
- Cisco 2620
- Cisco 2621
- Cisco 2650
- Cisco 2651
- Cisco 3620
- Cisco 3640
- Cisco 3661
- Cisco 3662
- Cisco uBR7223
- Cisco uBR7246
- Cisco uBR7246 VXR

Supported Standards and MIBs and RFCs

Standards

DOCSIS 1.0 and 1.0+. The DOCSIS 1.0+ implementation is DOCSIS 1.0 with quality-of-service (QoS) support.

MIBs

This feature is supported by:

- Cisco uBR7200 series MIBs and DOCSIS MIBs
- Frame Relay DTE MIB (RFC 1315)

To obtain lists of supported MIBs by platform and Cisco IOS release, and to download MIB modules, go to the Cisco MIB web site on cisco.com at the following URL:

<http://www.cisco.com/public/sw-center/netmgmt/cmtk/mibs.shtml> .

RFCs

- RFC 1315, *Management Information Base for Frame Relay DTEs*

Prerequisites

The routers and wireless links must be functioning properly to use this feature.

Configuration Tasks

- [Creating the Virtual Frame Relay Interface, page 112](#)
- [Verifying Virtual Frame Relay, page 113](#)
- [Troubleshooting Tips, page 113](#)

Creating the Virtual Frame Relay Interface

To create a virtual Frame Relay interface, enter these commands beginning in the global configuration mode:

SUMMARY STEPS

1. Router(config)# **interface virtual-framerelaynumber**
2. Router(config-if)# **frame-relay over radiointerface destination**

DETAILED STEPS

	Command or Action	Purpose
Step 1	Router(config)# interface virtual-framerelaynumber	Creates the virtual Frame Relay interface and assigns a number to the interface.
Step 2	Router(config-if)# frame-relay over radiointerface destination	Identifies the slot and port numbers of the interface.

Verifying Virtual Frame Relay

To verify that the interface is present, enter the **show interface virtual-framerelay** command.

Troubleshooting Tips

Verify that the multipoint wireless link is up and is working properly, then follow standard Frame Relay troubleshooting procedures.

Configuration Examples

- [Headend Example, page 113](#)
- [Subscriber Unit Example, page 114](#)

Headend Example

The example shows the virtual Frame Relay interface being created. The number assigned at the end of the **interface virtual-framerelay** command is the number assigned to the virtual interface. The **frame-relay over radio** command is used to link the interface to a specific MAC address after the interface has been created.

```
!
interface virtual-framerelay1
 ip address 10.6.24.20 255.255.0.0
 frame-relay map ip 11.6.24.21 16
 frame-relay intf-type dce
 frame-relay route 100 interface Hssi1/0 100
 frame-relay route 200 interface Hssi1/0 300
 frame-relay over Radio3/0 0002.b905.fc30
!
interface virtual-framerelay2
 ip address 10.30.36.12 255.255.255.0
 frame-relay map ip 11.30.36.12 16
 frame-relay intf-type dce
 frame-relay route 100 interface Hssi1/0 200
 frame-relay route 200 interface Hssi1/0 400
 frame-relay over Radio3/0 0002.fd50.bf90
interface Hssi1/0
 no ip address
 encapsulation frame-relay
 no ip mroute-cache
 hssi internal-clock
 frame-relay lmi-type cisco
 frame-relay intf-type dce
 frame-relay route 100 interface Virtual-FrameRelay1 100
 frame-relay route 200 interface Virtual-FrameRelay2 100
 frame-relay route 300 interface Virtual-FrameRelay1 200
 frame-relay route 400 interface Virtual-FrameRelay2 200
!
interface radio3/0 point-to-multipoint
 ip address 10.30.38.0 255.255.255.0
 no ip mroute-cache
 no keepalive
 radio cable-loss 1 4 1
 radio transmit-power 31
 radio upstream frequency 2156000 width 6.0
 radio upstream 0 subchannel 3 modulation-profile 8
 radio upstream 0 target-receive-power -72
 no radio upstream 0 shutdown
```

```

radio upstream 1 target-receive-power -72
radio upstream 1 shutdown
radio upstream 2 target-receive-power -72
radio upstream 2 shutdown
radio upstream 3 target-receive-power -72
radio upstream 3 shutdown
radio downstream frequency 2530000 width 6.0
radio downstream subchannel 2 modulation-profile 1
radio su-onoff-trap interval 600
interface virtual-frameRelay1
Virtual-FrameRelay1 is up, line protocol is up
Hardware is Virtual Frame Relay interface
MTU 1488 bytes, BW 100000 Kbit, DLY 100000 usec,
    reliability 255/255, txload 1/255, rxload 1/255
Encapsulation FRAME-RELAY, loopback not set
Keepalive set (10 sec)
LMI enq sent 0, LMI stat recvd 0, LMI upd recvd 0
LMI enq recvd 1175, LMI stat sent 1175, LMI upd sent 0, DCE LMI up
LMI DLCI 1023 LMI type is CISCO frame relay DCE
Broadcast queue 0/64, broadcasts sent/dropped 0/0, interface broadcasts 0
Last input 00:00:07, output never, output hang never
Last clearing of "show interface" counters 4d03h
Queueing strategy:fifo
Output queue 0/40, 0 drops; input queue 0/75, 0 drops
5 minute input rate 9000 bits/sec, 2 packets/sec
5 minute output rate 0 bits/sec, 0 packets/sec
2094 packets input, 229655 bytes, 0 no buffer
    Received 0 broadcasts, 0 runts, 0 giants, 0 throttles
    0 input errors, 0 CRC, 0 frame, 0 overrun, 0 ignored, 0 abort
    1175 packets output, 66954 bytes, 0 underruns
    0 output errors, 0 collisions, 0 interface resets
    0 output buffer failures, 0 output buffers swapped out
    0 carrier transitions

```

Subscriber Unit Example

The example shows the **interface virtual-framerelay** command being used on the subscriber unit to create the virtual Frame Relay interface. The **frame-relay over radio** command is used to link the interface to a specific MAC address, after the interface has been created.

```

interface virtual-framerelay1
ip address 11.6.24.21 255.255.0.0
frame-relay over Radiol/0 0030.80ac.a054
!
interface virtual-framerelay
1.1 point-to-point
ip address 192.168.0.0 255.255.255.0
no cdp enable
frame-relay interface-dlci 100
!
interface virtual-framerelay
1.2 multipoint
ip address 192.168.1.1 255.255.255.0
frame-relay map ip 192.168.1.0 200
!
interface radiol/0 point-to-multipoint
ip address docsis
no ip route-cache
no ip dvmrp auto-summary
no ip mroute-cache
docsis boot admin 2
docsis boot oper 5
docsis upstream channel 1 only
docsis mac-timer t2 180000
no docsis compliant bridge
radio cable-loss 1 2 1
no cdp enable
show interface virtual-frameRelay1
Virtual-FrameRelay1 is up, line protocol is up
Hardware is Virtual Frame Relay interface

```

```
MTU 1488 bytes, BW 100000 Kbit, DLY 100000 usec,  
  reliability 255/255, txload 1/255, rxload 1/255  
Encapsulation FRAME-RELAY, loopback not set  
Keepalive set (10 sec)  
LMI enq sent 1579, LMI stat recvd 1224, LMI upd recvd 0, DTE LMI up  
LMI enq recvd 0, LMI stat sent 0, LMI upd sent 0  
LMI DLCI 1023 LMI type is CISCO frame relay DTE  
Broadcast queue 0/64, broadcasts sent/dropped 0/0, interface broadcasts 0  
Last input 00:00:08, output never, output hang never  
Last clearing of "show interface" counters 4d03h  
Queueing strategy:fifo  
Output queue 0/40, 0 drops; input queue 0/75, 0 drops  
3 minutes, 30 seconds input rate 0 bits/sec, 0 packets/sec  
3 minutes, 30 seconds output rate 0 bits/sec, 0 packets/sec  
 1984 packets input, 395391 bytes, 0 no buffer  
  Received 0 broadcasts, 0 runts, 0 giants, 0 throttles  
  0 input errors, 0 CRC, 0 frame, 0 overrun, 0 ignored, 0 abort  
 2474 packets output, 875444 bytes, 0 underruns  
  0 output errors, 0 collisions, 0 interface resets  
  0 output buffer failures, 0 output buffers swapped out  
  0 carrier transitions
```

Cisco and the Cisco Logo are trademarks of Cisco Systems, Inc. and/or its affiliates in the U.S. and other countries. A listing of Cisco's trademarks can be found at www.cisco.com/go/trademarks. Third party trademarks mentioned are the property of their respective owners. The use of the word partner does not imply a partnership relationship between Cisco and any other company. (1005R)

Any Internet Protocol (IP) addresses and phone numbers used in this document are not intended to be actual addresses and phone numbers. Any examples, command display output, network topology diagrams, and other figures included in the document are shown for illustrative purposes only. Any use of actual IP addresses or phone numbers in illustrative content is unintentional and coincidental.



Frame Relay Queueing and Fragmentation at the Interface

The Frame Relay Queueing and Fragmentation at the Interface feature introduces support for low-latency queueing (LLQ) and FRF.12 end-to-end fragmentation on a Frame Relay interface.

- [Finding Feature Information, page 117](#)
- [Prerequisites for Frame Relay Queueing and Fragmentation at the Interface, page 117](#)
- [Restrictions for Frame Relay Queueing and Fragmentation at the Interface, page 118](#)
- [Information About Frame Relay Queueing and Fragmentation at the Interface, page 118](#)
- [How to Configure Frame Relay Queueing and Fragmentation at the Interface, page 119](#)
- [Configuration Examples for Frame Relay Queueing and Fragmentation at the Interface, page 128](#)
- [Additional References, page 129](#)
- [Feature Information for Frame Relay Queueing and Fragmentation at the Interface, page 130](#)

Finding Feature Information

Your software release may not support all the features documented in this module. For the latest feature information and caveats, see the release notes for your platform and software release. To find information about the features documented in this module, and to see a list of the releases in which each feature is supported, see the Feature Information Table at the end of this document.

Use Cisco Feature Navigator to find information about platform support and Cisco software image support. To access Cisco Feature Navigator, go to www.cisco.com/go/cfn. An account on Cisco.com is not required.

Prerequisites for Frame Relay Queueing and Fragmentation at the Interface

The tasks in this document assume that you know how to configure low-latency queueing and shaping service policies.

The following prerequisites are specific to the Cisco 7500 series:

- The Frame Relay Queueing and Fragmentation at the Interface feature is supported on VIP-based interfaces with VIP2-50 or higher.
- Distributed Cisco Express Forwarding (dCEF) must be enabled both globally and on the Frame Relay interface.

Restrictions for Frame Relay Queueing and Fragmentation at the Interface

- Interface fragmentation and Frame Relay traffic shaping cannot be configured at the same time.
- Interface fragmentation and class-based fragmentation cannot be configured at the same time.
- Frame Relay switched virtual circuits (SVCs) are not supported.
- Hierarchical shaping and multiple shapers are not supported.

Information About Frame Relay Queueing and Fragmentation at the Interface

The Frame Relay Queueing and Fragmentation at the Interface feature simplifies the configuration of low-latency, low-jitter quality of service (QoS) by enabling the queueing policy and fragmentation configured on the main interface to apply to all permanent virtual circuits (PVCs) and subinterfaces under that interface. Before the introduction of this feature, queueing and fragmentation had to be configured on each individual PVC. Subrate shaping can also be configured on the interface.

- [How Frame Relay Queueing and Fragmentation at the Interface Works, page 118](#)
- [Benefits of Frame Relay Queueing and Fragmentation at the Interface, page 119](#)

How Frame Relay Queueing and Fragmentation at the Interface Works

When FRF.12 end-to-end fragmentation is enabled on an interface, all PVCs on the main interface and its subinterfaces will have fragmentation enabled with the same configured fragment size. To maintain low latency and low jitter for high-priority traffic, the configured fragment size must be greater than the largest high-priority frames. This configuration will prevent high-priority traffic from being fragmented and queued behind lower-priority fragmented frames. If the size of a high-priority frame is larger than the configured fragment size, the high-priority frame will be fragmented. Local Management Interface (LMI) traffic will not be fragmented and is guaranteed its required bandwidth.

When a low-latency queueing policy map is applied to the interface, traffic through the interface is identified using class maps and is directed to the appropriate queue. Time-sensitive traffic such as voice should be classified as high priority and will be queued on the priority queue. Traffic that does not fall into one of the defined classes will be queued on the class-default queue. Frames from the priority queue and class queues are subject to fragmentation and interleaving. As long as the configured fragment size is larger than the high-priority frames, the priority queue traffic will not be fragmented and will be interleaved with fragmented frames from other class queues. This approach provides the highest QoS transmission for priority queue traffic. The figure below illustrates the interface queueing and fragmentation process.

Figure 15 Frame Relay Queueing and Fragmentation at the Interface

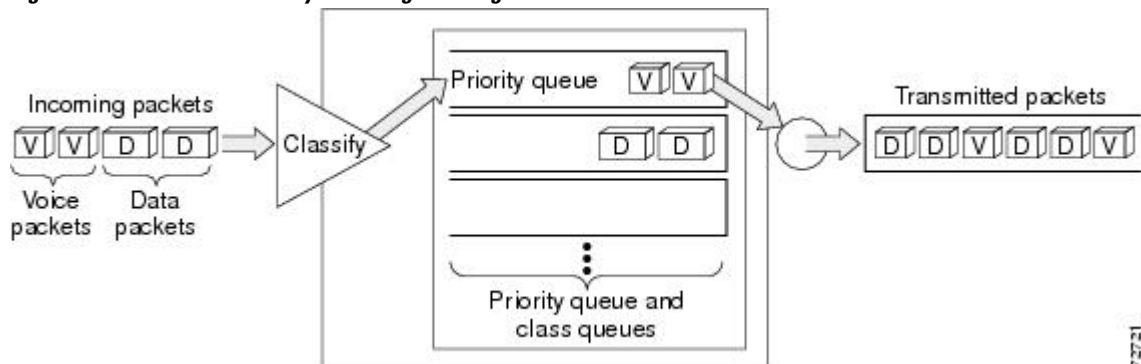

7-221

Subrate shaping can also be applied to the interface, but interleaving of high-priority frames will not work when shaping is configured. If shaping is not configured, each PVC will be allowed to send bursts of traffic up to the physical line rate.

When shaping is configured and traffic exceeds the rate at which the shaper can send frames, the traffic is queued at the shaping layer using fair queueing. After a frame passes through the shaper, the frame is queued at the interface using whatever queueing method is configured. If shaping is not configured, then queueing occurs only at the interface.

**Note**

For interleaving to work, both fragmentation and the low-latency queueing policy must be configured with shaping disabled.

The Frame Relay Queueing and Fragmentation at the Interface feature supports the following functionality:

- Voice over Frame Relay
- Weighted Random Early Detection
- Frame Relay payload compression

**Note**

When payload compression and Frame Relay fragmentation are used at the same time, payload compression is always performed before fragmentation.

- IP header compression

Benefits of Frame Relay Queueing and Fragmentation at the Interface

Simple Configuration

The Frame Relay Queueing and Fragmentation at the Interface feature allows fragmentation, low-latency queueing, and subrate shaping to be configured on a Frame Relay interface queue. The fragmentation and queueing and shaping policy will apply to all PVCs and subinterfaces under the main interface, eliminating the need to configure QoS on each PVC individually.

Flexible Bandwidth

This feature allows PVCs to preserve the logical separation of traffic from different services while reducing bandwidth partitioning between PVCs. Each PVC can send bursts of traffic up to the interface shaping rate or, if shaping is not configured, the physical interface line rate.

How to Configure Frame Relay Queueing and Fragmentation at the Interface

- [Configuring Class Policy for the Priority Queue, page 120](#)
- [Configuring Class Policy for the Bandwidth Queues, page 121](#)
- [Configuring the Shaping Policy Using the Class-Default Class, page 122](#)
- [Configuring Queueing and Fragmentation on the Frame Relay Interface, page 123](#)
- [Verifying Frame Relay Queueing and Fragmentation at the Interface, page 125](#)

- [Monitoring and Maintaining Frame Relay Queueing and Fragmentation at the Interface, page 127](#)

Configuring Class Policy for the Priority Queue

To configure a policy map for the priority class, use the following commands beginning in global configuration mode:

SUMMARY STEPS

1. **enable**
2. **configure terminal**
3. **policy-map** *policy-map*
4. **class** *class-name*
5. Router(config-pmap-c)# **priority** *bandwidth-kbps*
6. **exit**

DETAILED STEPS

Command or Action	Purpose
Step 1 enable Example: Router> enable	Enables privileged EXEC mode. <ul style="list-style-type: none"> • Enter your password if prompted.
Step 2 configure terminal Example: Router# configure terminal	Enters global configuration mode.
Step 3 policy-map <i>policy-map</i> Example: Router(config) policy-map policy1	Specifies the name of the policy map to be created or modified. <ul style="list-style-type: none"> • Use this command to define the queueing policy for the priority queue.
Step 4 class <i>class-name</i> Example: Router(config-pmap)# class c1	Specifies the name of a class to be created and included in the service policy. <ul style="list-style-type: none"> • The class name that you specify in the policy map defines the characteristics for that class and its match criteria as configured using the class-map command.
Step 5 Router(config-pmap-c)# priority <i>bandwidth-kbps</i> Example: Router(config-pmap-c)# priority 30	Creates a strict priority class and specifies the amount of bandwidth, in kbps, to be assigned to the class.

Command or Action	Purpose
Step 6 <code>exit</code> Example: <code>Router(config-pmap-c)# exit</code>	Exits the current configuration mode.

Configuring Class Policy for the Bandwidth Queues

To configure a policy map and create class policies that make up the service policy, use the following commands beginning in global configuration mode:

SUMMARY STEPS

1. `enable`
2. `configure terminal`
3. `policy-map policy-map`
4. `class class-name`
5. `Router(config-pmap-c)# bandwidth bandwidth-kbps`
6. `exit`

DETAILED STEPS

Command or Action	Purpose
Step 1 <code>enable</code> Example: <code>Router> enable</code>	Enables privileged EXEC mode. <ul style="list-style-type: none"> • Enter your password if prompted.
Step 2 <code>configure terminal</code> Example: <code>Router# configure terminal</code>	Enters global configuration mode.
Step 3 <code>policy-map <i>policy-map</i></code> Example: <code>Router(config)# policy-map policy1</code>	Specifies the name of the policy map to be created or modified. <ul style="list-style-type: none"> • Use this command to define the queueing policy for the priority queue. • The bandwidth queues and the priority queue use the same policy map.
Step 4 <code>class <i>class-name</i></code> Example: <code>Router(config-pmap)# class c1</code>	Specifies the name of a class to be created and included in the service policy. <ul style="list-style-type: none"> • The class name that you specify in the policy map defines the characteristics for that class and its match criteria as configured using the class-map command.

Command or Action	Purpose
<p>Step 5 Router(config-pmap-c)# bandwidth <i>bandwidth-kbps</i></p> <p>Example: Router(config-pmap-c)# bandwidth 10</p>	<p>Specifies the amount of bandwidth to be assigned to the class, in kbps, or as a percentage of the available bandwidth. Bandwidth must be specified in kbps or as a percentage consistently across classes. (Bandwidth of the priority queue must be specified in kbps.)</p> <ul style="list-style-type: none"> The sum of all bandwidth allocation on an interface cannot exceed 75 percent of the total available interface bandwidth. However, if you need to configure more than 75 percent of the interface bandwidth to classes, you can override the 75 percent maximum by using the max-reserved-bandwidth command.
<p>Step 6 exit</p> <p>Example: Router(config-pmap-c)# exit</p>	<p>Exits the current configuration mode.</p>

Configuring the Shaping Policy Using the Class-Default Class

In general, the class-default class is used to classify traffic that does not fall into one of the defined classes. Even though the class-default class is predefined when you create the policy map, you still have to configure it. If a default class is not configured, traffic that does not match any of the configured classes is given best-effort treatment, which means that the network will deliver the traffic if it can, without any assurance of reliability, delay prevention, or throughput.

If you configure shaping in addition to queueing on the interface, use the class-default class to configure the shaping policy. The shaping policy will serve as the parent in a hierarchical traffic policy. The queueing policy will serve as the child policy. The class-default class is used for the shaping policy so that all traffic for the entire interface is shaped and a bandwidth-limited stream can be created.

To configure the shaping policy in the class-default class, use the following commands beginning in global configuration mode:

SUMMARY STEPS

- enable**
- configure terminal**
- policy-map** *policy-map*
- class class-default**
- shape** [**average** | **peak**] *mean-rate* [[*burst-size*] [*excess-burst-size*]]
- service-policy** *policy-map-name*
- exit**

DETAILED STEPS

Command or Action	Purpose
<p>Step 1 <code>enable</code></p> <p>Example: Router> enable</p>	<p>Enables privileged EXEC mode.</p> <ul style="list-style-type: none"> Enter your password if prompted.
<p>Step 2 <code>configure terminal</code></p> <p>Example: Router# configure terminal</p>	<p>Enters global configuration mode.</p>
<p>Step 3 <code>policy-map policy-map</code></p> <p>Example: Router(config)# policy-map policy1</p>	<p>Specifies the name of the policy map to be created or modified.</p> <ul style="list-style-type: none"> Use this command to define the shaping policy.
<p>Step 4 <code>class class-default</code></p> <p>Example: Router(config-pmap)# class class-default</p>	<p>Specifies the default class so that you can configure or modify its policy.</p>
<p>Step 5 <code>shape [average peak] mean-rate [[burst-size] [excess-burst-size]]</code></p> <p>Example: Router(config-pmap-c)# shape peak 10</p>	<p>(Optional) Shapes traffic to the indicated bit rate according to the algorithm specified.</p>
<p>Step 6 <code>service-policy policy-map-name</code></p> <p>Example: Router(config-pmap-c)# service-policy policy1</p>	<p>Specifies the name of a policy map to be used as a matching criterion (for nesting traffic policies [hierarchical traffic policies] within one another).</p> <ul style="list-style-type: none"> Use this command to attach the policy map for the priority queue (the child policy) to the shaping policy (the parent policy).
<p>Step 7 <code>exit</code></p> <p>Example: Router(config-pmap-c)# exit</p>	<p>Exits the current configuration mode.</p>

Configuring Queueing and Fragmentation on the Frame Relay Interface

To configure low-latency queueing and FRF.12 end-to-end fragmentation on a Frame Relay interface, use the following commands beginning in global configuration mode:

SUMMARY STEPS

1. **enable**
2. **configure terminal**
3. **interface** *type / number*
4. **encapsulation frame-relay**
5. **service-policy output** *policy-map-name*
6. **frame-relay fragment** *fragment-size* **end-to-end**
7. **exit**

DETAILED STEPS

	Command or Action	Purpose
Step 1	enable Example: Router> enable	Enables privileged EXEC mode. <ul style="list-style-type: none"> • Enter your password if prompted.
Step 2	configure terminal Example: Router# configure terminal	Enters global configuration mode.
Step 3	interface <i>type / number</i> Example: Router(config)# interface fe 0/0	Configures an interface type and enters interface configuration mode.
Step 4	encapsulation frame-relay Example: Router(config-if)# encapsulation frame-relay	Enables Frame Relay encapsulation.

Command or Action	Purpose
<p>Step 5 <code>service-policy output</code> <i>policy-map-name</i></p> <p>Example:</p> <pre>Router(config-if)# service-policy output policy1</pre>	<p>Attaches a policy map to an output interface, to be used as the service policy for that interface.</p> <ul style="list-style-type: none"> • If shaping is being used, use this command to attach the shaping policy (which includes the nested queueing policy) to the interface. • Interleaving of high-priority frames will not work if shaping is configured on the interface. • If shaping is not being used, use this command to attach the queueing policy to the interface.
<p>Step 6 <code>frame-relay fragment</code> <i>fragment-size</i> end-to-end</p> <p>Example:</p> <pre>Router(config-if)# frame-relay fragment 100 end-to-end</pre>	<p>Enables fragmentation of Frame Relay frames.</p> <ul style="list-style-type: none"> • To maintain low latency and low jitter for priority queue traffic, configure the fragment size to be greater than the largest high-priority frame that would be expected.
<p>Step 7 <code>exit</code></p> <p>Example:</p> <pre>Router(config-if)# exit</pre>	<p>Exits the current configuration mode.</p>

Verifying Frame Relay Queueing and Fragmentation at the Interface

To verify the configuration and performance of Frame Relay queueing and fragmentation at the interface, perform the following steps:

SUMMARY STEPS

1. Enter the **show running-config** command to verify the configuration.
2. Enter the **show policy-map interface** command to display low-latency queueing information, packet counters, and statistics for the policy map applied to the interface. Compare the values in the "packets" and the "pkts matched" counters; under normal circumstances, the "packets" counter is much larger than the "pkts matched" counter. If the values of the two counters are nearly equal, then the interface is receiving a large number of process-switched packets or is heavily congested.
3. Enter the **show interfaces serial** command to display information about the queueing strategy, priority queue interleaving, and type of fragmentation configured on the interface. You can determine whether the interface has reached a congestion condition and packets have been queued by looking at the "Conversations" fields. A nonzero value for "max active" counter shows whether any queues have been active. If the "active" counter is a nonzero value, you can use the **show queue** command to view the contents of the queues.

DETAILED STEPS

Step 1 Enter the **show running-config** command to verify the configuration.

Example:

```
Router# show running-config
Building configuration...
.
.
.
class-map match-all voice
  match ip precedence 5
!
!policy-map llq
  class voice
    priority 64
policy-map shaper
  class class-default
    shape peak 96000
    service-policy llq
!
!interface Serial1/1
  ip address 16.0.0.1 255.255.255.0
  encapsulation frame-relay
  service-policy output shaper
  frame-relay fragment 80 end-to-end
!
```

Step 2 Enter the **show policy-map interface** command to display low-latency queueing information, packet counters, and statistics for the policy map applied to the interface. Compare the values in the "packets" and the "pkts matched" counters; under normal circumstances, the "packets" counter is much larger than the "pkts matched" counter. If the values of the two counters are nearly equal, then the interface is receiving a large number of process-switched packets or is heavily congested.

The following sample output for the **show policy-map interface** command is based on the configuration in Step 1:

Example:

```
Router# show policy-map interface serial 1/1
Serial1/1
  Service-policy output:shaper
    Class-map: class-default (match-any)
      12617 packets, 1321846 bytes
      5 minute offered rate 33000 bps, drop rate 0 bps
    Match: any
    Traffic Shaping
      Target/Average Rate      Byte Limit      Sustain Excess      Interval Increment
      Rate                      bits/int    bits/int    bits/int    (ms)        (bytes)
      192000/96000              1992       7968        7968        83          1992
    Adapt Queue Packets      Bytes      Packets      Bytes      Shaping
    Active Depth -          0          12586       1321540    0          Delayed    Delayed    Active
    Service-policy : llq
      Class-map: voice (match-all)
        3146 packets, 283140 bytes
        5 minute offered rate 7000 bps, drop rate 0 bps
      Match: ip precedence 1
      Weighted Fair Queueing
        Strict Priority
        Output Queue: Conversation 24
        Bandwidth 64 (kbps) Burst 1600 (Bytes)
        (pkts matched/bytes matched) 0/0
        (total drops/bytes drops) 0/0
```

```

Class-map: class-default (match-any)
  9471 packets, 1038706 bytes
  5 minute offered rate 26000 bps
  Match: any

```

Step 3

Enter the **show interfaces serial** command to display information about the queueing strategy, priority queue interleaving, and type of fragmentation configured on the interface. You can determine whether the interface has reached a congestion condition and packets have been queued by looking at the "Conversations" fields. A nonzero value for "max active" counter shows whether any queues have been active. If the "active" counter is a nonzero value, you can use the **show queue** command to view the contents of the queues.

The following sample output for the **show interfaces serial** command is based on the configuration in Step 1:

Example:

```

Router# show interfaces serial 1/1
Serial1/1 is up, line protocol is up
  Hardware is M4T
  Internet address is 16.0.0.1/24
  MTU 1500 bytes, BW 1544 Kbit, DLY 20000 usec,
    reliability 255/255, txload 5/255, rxload 1/255
  Encapsulation FRAME-RELAY, crc 16, loopback not set
  Keepalive set (10 sec)
  Restart-Delay is 0 secs
  LMI enq sent 40, LMI stat recvd 40, LMI upd recvd 0, DTE LMI up
  LMI enq recvd 0, LMI stat sent 0, LMI upd sent 0
  LMI DLCI 1023 LMI type is CISCO frame relay DTE
  Fragmentation type: end-to-end, size 80, PQ interleaves 0
  Broadcast queue 0/64, broadcasts sent/dropped 0/0, interface broadcasts 0
  Last input 00:00:03, output 00:00:00, output hang never
  Last clearing of "show interface" counters 00:06:34
  Input queue: 0/75/0/0 (size/max/drops/flushes); Total output drops: 0
  Queueing strategy: weighted fair
  Output queue: 0/1000/64/0 (size/max total/threshold/drops)
    Conversations 0/1/256 (active/max active/max total)
    Reserved Conversations 0/0 (allocated/max allocated)
    Available Bandwidth 1158 kilobits/sec
  5 minute input rate 0 bits/sec, 0 packets/sec
  5 minute output rate 33000 bits/sec, 40 packets/sec
    40 packets input, 576 bytes, 0 no buffer
    Received 0 broadcasts, 0 runts, 0 giants, 0 throttles
    0 input errors, 0 CRC, 0 frame, 0 overrun, 0 ignored, 0 abort
    15929 packets output, 1668870 bytes, 0 underruns
    0 output errors, 0 collisions, 0 interface resets
    0 output buffer failures, 0 output buffers swapped out
    0 carrier transitions      DCD=up DSR=up DTR=up RTS=up CTS=up

```

Monitoring and Maintaining Frame Relay Queueing and Fragmentation at the Interface

To monitor and maintain Frame Relay queueing and fragmentation at the interface, use the following commands in privileged EXEC mode:

SUMMARY STEPS

1. **debug frame-relay fragment** [*event* | *interface type / number dlc*]
2. **show frame-relay fragment** [*interface type / number [dlci]*]
3. **show interfaces serial** *number*
4. **show queue** *interface-type interface-number*
5. **show policy-map interface** *number* [*input* | *output*]

DETAILED STEPS

-
- | | |
|---------------|---|
| Step 1 | debug frame-relay fragment [<i>event</i> <i>interface type / number dlc</i>]
Displays information related to Frame Relay fragmentation on a PVC. |
| Step 2 | show frame-relay fragment [<i>interface type / number [dlci]</i>]
Displays information about Frame Relay fragmentation. |
| Step 3 | show interfaces serial <i>number</i>
Displays information about a serial interface. |
| Step 4 | show queue <i>interface-type interface-number</i>
Displays the contents of packets inside a queue for a particular interface. |
| Step 5 | show policy-map interface <i>number</i> [<i>input</i> <i>output</i>]
Displays the packet statistics of all classes that are configured for all service policies on the specified interface. |
-

Configuration Examples for Frame Relay Queueing and Fragmentation at the Interface

- [Example Frame Relay Queueing Shaping and Fragmentation at the Interface, page 128](#)
- [Example Frame Relay Queueing and Fragmentation at the Interface, page 129](#)

Example Frame Relay Queueing Shaping and Fragmentation at the Interface

The following example shows the configuration of a hierarchical policy for low-latency queueing, FRF.12 fragmentation, and shaping on serial interface 3/2. Note that traffic from the priority queue will not be interleaved with fragments from the class-default queue because shaping is configured.

```
class-map voice
 match access-group 101

policy-map llq
 class voice
  priority 64

policy-map shaper
 class class-default
  shape average 96000
  service-policy llq
interface serial 3/2
 ip address 10.0.0.1 255.0.0.0
```



```

encapsulation frame-relay
bandwidth 128
clock rate 128000
service-policy output shaper
frame-relay fragment 80 end-to-end

access-list 101 match ip any host 10.0.0.2

```

Example Frame Relay Queueing and Fragmentation at the Interface

The following example shows the configuration of low-latency queueing and FRF.12 fragmentation on serial interface 3/2. Because shaping is not being used, a hierarchical traffic policy is not needed and traffic from the priority queue will be interleaved with fragments from the other queues. Without shaping, the output rate of the interface is equal to the line rate or configured clock rate. In this example, the clock rate is 128,000 bps.

```

class-map voice
match access-group 101

policy-map llq
class voice
priority 64
class video
bandwidth 32
interface serial 3/2
ip address 10.0.0.1 255.0.0.0
encapsulation frame-relay
bandwidth 128
clock rate 128000
service-policy output llq
frame-relay fragment 80 end-to-end
access-list 101 match ip any host 10.0.0.2

```

Additional References

Related Documents

Related Topic	Document Title
Cisco IOS commands	Cisco IOS Master Commands List, All Releases
WAN commands	<i>Cisco IOS Wide-Area Networking Command Reference</i>
Configuring Frame Relay	Configuring Frame Relay

Standards

Standard	Title
FRF.12	<i>Frame Relay Fragmentation Implementation Agreement</i> , December 1997

MIBs

MIB	MIBs Link
None	To locate and download MIBs for selected platforms, Cisco software releases, and feature sets, use Cisco MIB Locator found at the following URL: http://www.cisco.com/go/mibs

RFCs

RFC	Title
None	--

Technical Assistance

Description	Link
<p>The Cisco Support website provides extensive online resources, including documentation and tools for troubleshooting and resolving technical issues with Cisco products and technologies.</p> <p>To receive security and technical information about your products, you can subscribe to various services, such as the Product Alert Tool (accessed from Field Notices), the Cisco Technical Services Newsletter, and Really Simple Syndication (RSS) Feeds.</p> <p>Access to most tools on the Cisco Support website requires a Cisco.com user ID and password.</p>	http://www.cisco.com/cisco/web/support/index.html

Feature Information for Frame Relay Queueing and Fragmentation at the Interface

The following table provides release information about the feature or features described in this module. This table lists only the software release that introduced support for a given feature in a given software release train. Unless noted otherwise, subsequent releases of that software release train also support that feature.

Use Cisco Feature Navigator to find information about platform support and Cisco software image support. To access Cisco Feature Navigator, go to www.cisco.com/go/cfn. An account on Cisco.com is not required.

Table 4 **Feature Information for Frame Relay Queueing and Fragmentation at the Interface**

Feature Name	Releases	Feature Information
Frame Relay Queueing and Fragmentation at the Interface	12.2(11)S 12.2(13)T 15.0(1)S	<p>The Frame Relay Queueing and Fragmentation at the Interface feature introduces support for low-latency queueing (LLQ) and FRF.12 end-to-end fragmentation on a Frame Relay interface.</p> <p>The following commands were introduced or modified: frame-relay fragment end-to-end, show interfaces serial.</p>

Cisco and the Cisco Logo are trademarks of Cisco Systems, Inc. and/or its affiliates in the U.S. and other countries. A listing of Cisco's trademarks can be found at www.cisco.com/go/trademarks. Third party trademarks mentioned are the property of their respective owners. The use of the word partner does not imply a partnership relationship between Cisco and any other company. (1005R)

Any Internet Protocol (IP) addresses and phone numbers used in this document are not intended to be actual addresses and phone numbers. Any examples, command display output, network topology diagrams, and other figures included in the document are shown for illustrative purposes only. Any use of actual IP addresses or phone numbers in illustrative content is unintentional and coincidental.



Frame Relay PVC Bundles with QoS Support for IP and MPLS

Frame Relay permanent virtual circuit (PVC) bundle functionality allows you to associate a group of Frame Relay PVCs with a single next-hop address. When Frame Relay PVC bundles are used with IP, packets are mapped to specific PVCs in the bundle on the basis of the precedence value or differentiated services code point (DSCP) settings in the type of service (ToS) field of the IP header. Each packet is treated differently according to the QoS configured for each PVC.

MPLS QoS support for Frame Relay PVC bundles extends Frame Relay PVC bundle functionality to support the mapping of Multiprotocol Label Switching (MPLS) packets to specific PVCs in the bundle. MPLS packets are mapped to PVCs according to the settings of the experimental (EXP) bits in the MPLS packet header.

- [Finding Feature Information, page 133](#)
- [Prerequisites for Frame Relay PVC Bundles with QoS Support for IP and MPLS, page 134](#)
- [Restrictions for Frame Relay PVC Bundles with QoS Support for IP and MPLS, page 134](#)
- [Information About Frame Relay PVC Bundles with QoS Support for IP and MPLS, page 134](#)
- [How to Configure Frame Relay PVC Bundles with QoS Support for IP and MPLS, page 137](#)
- [Configuration Examples for Frame Relay PVC Bundles with QoS Support for IP and MPLS, page 149](#)
- [Additional References, page 155](#)
- [Feature Information for Frame Relay PVC Bundles with QoS Support for IP and MPLS, page 156](#)
- [Glossary, page 157](#)

Finding Feature Information

Your software release may not support all the features documented in this module. For the latest feature information and caveats, see the release notes for your platform and software release. To find information about the features documented in this module, and to see a list of the releases in which each feature is supported, see the Feature Information Table at the end of this document.

Use Cisco Feature Navigator to find information about platform support and Cisco software image support. To access Cisco Feature Navigator, go to www.cisco.com/go/cfn. An account on Cisco.com is not required.

Prerequisites for Frame Relay PVC Bundles with QoS Support for IP and MPLS

To implement Frame Relay PVC bundles between two routers, you must enable IP Cisco Express Forwarding switching on the routers.

To configure MPLS EXP levels on bundle member PVCs, you must have tag-switching enabled on the interface.

It is recommended (but not required) that you implement PVC Interface Priority Queueing (PIPQ) in conjunction with Frame Relay PVC bundles. This will ensure that if the interface becomes congested, higher-priority traffic can exit the interface ahead of lower-priority traffic.

Restrictions for Frame Relay PVC Bundles with QoS Support for IP and MPLS

- A PVC can be a part of one and only one PVC bundle.
- A PVC bundle may contain no more than eight PVCs.
- A PVC that is a bundle member cannot be used in any other capacity. For example a PVC bundle member cannot be configured in a map statement.
- A PVC bundle cannot perform precedence and DSCP matching at the same time. If the wrong matching scheme is configured, unpredictable behavior will result.
- A PVC bundle will not come up unless all the precedence, DSCP, or EXP levels are configured in the bundle.
- Voice over Frame Relay (VoFR) is not supported on PVC-bundle members.
- Fast switching over Frame Relay PVC bundles is not supported.

Information About Frame Relay PVC Bundles with QoS Support for IP and MPLS

- [Benefits of Frame Relay PVC Bundles with QoS Support for IP and MPLS](#), page 134
- [Frame Relay PVC Bundle Support](#), page 135
- [Frame Relay PVC Bundle Management](#), page 136

Benefits of Frame Relay PVC Bundles with QoS Support for IP and MPLS

- IP or MPLS packets carrying different types of traffic can be transported on different PVCs within the same PVC bundle.
- Precedence-based PVC bundles can be converted to EXP-based PVC bundles by enabling tag-switching. EXP-based PVC bundles can be converted to precedence-based PVC bundles by disabling tag-switching.

- This feature provides flexible PVC management within a PVC bundle by allowing traffic assigned to a failed PVC to be redirected to an alternate PVC within the bundle. This feature also allows you to configure the bundle to go down when certain PVCs go down.

Frame Relay PVC Bundle Support

The use of Frame Relay PVC bundles allows you to configure multiple PVCs with different QoS characteristics between any pair of Frame Relay-connected routers. As shown in the figure below, a PVC bundle may contain up to eight PVCs. The individual PVCs within a bundle are called *bundle members*.

To determine which PVC in a bundle will be used to forward a specific type of traffic, the router maps the IP precedence level or DSCP value in an IPv4 packet header to a PVC configured with the same value. In the case of MPLS, packets are mapped to specific PVCs in a bundle based on the settings of the EXP bits in the MPLS packet headers.

Once you define a Frame Relay bundle and add PVCs to it, you can configure attributes and characteristics to discrete PVC bundle members, or you can apply them collectively at the bundle level. Frame Relay traffic shaping may be applied to every PVC within a bundle. As with individual PVCs, you can enable rate adaptation to occur in response to incoming backward explicit congestion notifications (BECN) from the network.

Figure 16 Frame Relay PVC bundle

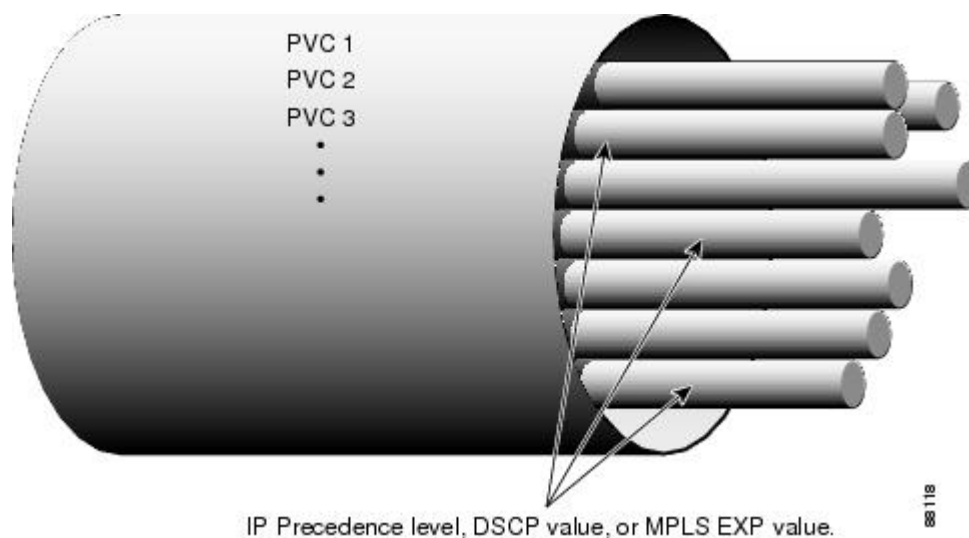

You can create differentiated service using PVC bundles by distributing IP precedence levels or DSCP values over the various bundle members. You can map either a single precedence level or a range of precedence levels to each PVC in the bundle. Thus, either you can limit an individual PVC to carry only packets marked with a specific precedence level or you can enable a PVC to carry packets marked with different precedence levels.

- [Service Levels and PVC Selection Criteria, page 135](#)

Service Levels and PVC Selection Criteria

The DSCP and Precedence bits classify IP packet service levels. The Precedence field consists of the first three bits of the ToS octet in the IPv4 header. These bits define eight precedence levels. When DSCP

mapping is used, the DSCP octet replaces the ToS octet in the IPv4 header. Currently the first six bits are used, defining 64 service levels.

Using precedence-based or DSCP-based mapping, each IPv4 packet is mapped to a specific PVC in the bundle, according to the value of the ToS or DSCP octet in the IP header. There is no special treatment for broadcast or multicast or IP routing packets; the only differentiation in treatment is a result of the ToS or DSCP octet settings.

The MPLS EXP bits make up a three-bit experimental field in the MPLS packet header. They are a bit-by-bit copy of the IP Precedence bits and provide the same eight QoS levels. Under MPLS EXP-based mapping, each MPLS packet is mapped to a specific PVC in the bundle, according to the setting of the EXP bits.

Frame Relay PVC Bundle Management

In addition to mapping specific traffic types to specific PVCs according to QoS parameters designated by the ToS or DSCP values in the IPv4 headers or EXP values in the MPLS headers, PVC bundle management takes care of handling non-IP traffic and determining what happens if a PVC goes down.

By default, Inverse Address Resolution Protocol (ARP) traffic and other critical non-IP traffic is carried by the PVC configured for carrying IP Precedence or EXP level 6 or DSCP level 63. You can select a PVC with a different QoS to carry Inverse ARP traffic if required. Noncritical non-IP traffic is carried by the PVC that configured for carrying IP precedence, EXP, or DSCP level 0.

It is important during configuration to account for every precedence, EXP, or DSCP level in the configuration of the PVC bundle members. If all the packet service levels are not accounted for, the PVC bundle will never come up.

Once a PVC bundle is up, if an individual bundle member goes down, an attempt is made to identify an alternate PVC to handle the packet service level or levels that were carried by the downed PVC. If no alternate PVC is found, the entire PVC bundle is brought down.

- [Traffic Bumping, page 136](#)
- [PVC-Bundle Protection Rules, page 136](#)
- [MPLS EXP-based Mapping, page 137](#)

Traffic Bumping

You can configure each PVC bundle member to bump traffic to another PVC in the bundle in the event that the bundle member goes down. You can specify whether the bumping will be implicit or explicit bumping. You can also specify that a particular PVC will never accept bumped traffic from another PVC. The default conditions are to perform implicit traffic bumping and to accept bumped traffic.

Implicit bumping diverts the traffic from a failed PVC to the PVC having the next-lower service level. Explicit bumping forces the traffic to a specific PVC rather than allowing it to find a PVC carrying traffic of the next-lower service level. For example, PVC *x*, responsible for carrying precedence level 3 traffic, can be configured to bump its traffic to PVC *y*, responsible for carrying precedence level 6 traffic--provided that PVC *y* is configured to accept bumped traffic. If PVC *x* goes down, PVC *y* takes over. If PVC *y* is already down or goes down later, the alternate PVC selected will depend on the bumping rule for PVC *y*. If no alternate PVC can be found for bumped traffic, the entire PVC bundle goes down.

PVC-Bundle Protection Rules

Traffic bumping provides a way to keep a PVC bundle up and traffic flowing even though some individual PVCs may be down. Protection rules provide a way to force the PVC bundle down even though some

individual PVCs are up and might be able to handle all the traffic, though perhaps not in a satisfactory manner.

You can configure a PVC bundle member as an individually protected PVC or as part of a PVC bundle protected group. Only one protected group may exist within a PVC bundle; however, many individually protected PVCs may exist. The protection rules add flexibility for controlling the PVC bundle state.

When any one individually protected PVC goes down, the entire bundle goes down. If all the PVCs in a protected group go down, the entire bundle goes down.

If no protection rule is specified, the PVC bundle goes down only when all the PVCs go down. However, protection is overridden if a PVC that has no place to bump its traffic goes down. In this case, the entire bundle will go down despite any protection rules that have been set up.

MPLS EXP-based Mapping

To enable MPLS EXP-based mapping, tag-switching must be enabled on the interface or subinterface by using the **tag-switching ip** command. When tag-switching is enabled, MPLS and IP packets can flow across the interface and PVC bundles that are configured for IP Precedence mapping are converted to MPLS EXP mapping. The PVC bundle functionality remains the same with respect to priority levels, bumping, and so on, but the **match precedence** command is replaced by **match exp**, and each **precedence** command is replaced by the **exp** command. The effect is that a bundle member PVC previously configured to carry precedence level 1 IP traffic now carries EXP level 1 MPLS traffic.

PVC bundles configured for DSCP mapping go down when tag-switching is enabled. The DSCP configuration for each bundle member PVC is reset, resulting in the PVCs being unmapped and Inverse ARP, bumping, and protection settings being unconfigured. The **match dscp** command is replaced by **match exp** command.

When tag-switching is disabled, the **match precedence** and **match dscp** commands are restored and the **exp** commands are replaced by **precedence** commands.

When tag-switching is enabled or disabled, PVC bundles configured for IP precedence mapping or MPLS EXP mapping will stay up and traffic will transmit over the appropriate bundle member PVCs.

How to Configure Frame Relay PVC Bundles with QoS Support for IP and MPLS

- [Configuring Frame Relay PVC Bundles with IP QoS Support, page 137](#)
- [Configuring Frame Relay PVC Bundles with MPLS QoS Support, page 142](#)
- [Verifying Frame Relay PVC Bundles Configuration, page 147](#)
- [Monitoring and Maintaining Frame Relay PVC Bundles, page 148](#)

Configuring Frame Relay PVC Bundles with IP QoS Support

To configure Frame Relay PVC bundles for handling IP packets, perform the following steps:

SUMMARY STEPS

1. **enable**
2. **configure terminal**
3. **ip routing**
4. **ip cef**
5. Do one of the following:
 - **interface** *type number*
 -
 -
 - **interface** *type number . subinterface-number*
 - **multipoint** | **point-to-point**
6. **encapsulation frame-relay** [**cisco** | **ietf**]
7. **ip address** *ip-address mask* [**secondary**]
8. **frame-relay map** *protocol protocol-address* { *dlci* | **vc-bundle** *vc-bundle-name* } [**broadcast**] [**ietf** | **cisco**]
9. **frame-relay vc-bundle** *vc-bundle-name*
10. **encapsulation** [**cisco** | **ietf**]
11. **match** { **dscp** *dscp-value* | **precedence** *precedence-value* }
12. **pvc** *dlci* [*vc-name*]
13. **class** *name*
14. Do one of the following:
 - **precedence** { *level* | **other** }
 -
 -
 - **dscp** { *level* | **other** }
15. **bump** { **explicit** *level* | **implicit** | **traffic** }
16. **protect** { **group** | **vc** }
17. **inarp**
18. **end**
19. Configure the PVC bundle on the peer router.

DETAILED STEPS

	Command or Action	Purpose
Step 1	enable	Enables privileged EXEC mode. <ul style="list-style-type: none"> • Enter your password if prompted.
	Example:	
	Router> enable	

	Command or Action	Purpose
Step 2	<p>configure terminal</p> <p>Example:</p> <pre>Router# configure terminal</pre>	<p>Enters global configuration mode.</p>
Step 3	<p>ip routing</p> <p>Example:</p> <pre>Router(config)# ip routing</pre>	<p>Enables IP routing.</p>
Step 4	<p>ip cef</p> <p>Example:</p> <pre>Router(config)# ip cef</pre>	<p>Enables Cisco Express Forwarding.</p> <p>Note For the Cisco 7500, enter ip cef distributed.</p>
Step 5	<p>Do one of the following:</p> <ul style="list-style-type: none"> • interface <i>type number</i> • • • interface <i>type number . subinterface-number</i> • multipoint point-to-point <p>Example:</p> <pre>Router(config)# interface serial 0</pre> <p>Example:</p> <p>Example:</p> <pre>Router(config)# interface serial 1.1 multipoint</pre>	<p>Specifies the interface type and number and enters interface configuration mode.</p> <ul style="list-style-type: none"> • Physical interfaces are multipoint subinterfaces by default. <p>or</p> <p>Specifies the interface type and subinterface and enters subinterface configuration mode.</p> <ul style="list-style-type: none"> • Once you create a specific type of subinterface (point-to-point or multipoint), you cannot change it without a reload. To change it, you must either reload the router or create another subinterface.

Command or Action	Purpose
<p>Step 6 encapsulation frame-relay [cisco ietf]</p> <p>Example:</p> <pre>Router(config-if)# encapsulation frame-relay</pre>	<p>Enables Frame Relay encapsulation.</p> <ul style="list-style-type: none"> The default encapsulation method is cisco.
<p>Step 7 ip address <i>ip-address mask</i> [secondary]</p> <p>Example:</p> <pre>Router(config-if)# ip address 10.1.1.1 255.0.0.0</pre>	<p>Sets a primary IP address for the interface.</p> <ul style="list-style-type: none"> The optional secondary keyword specifies that the configured address is a secondary IP address. If this keyword is omitted, the configured address is the primary IP address.
<p>Step 8 frame-relay map <i>protocol protocol-address {dlci vc-bundle vc-bundle-name}</i> [broadcast] [ietf cisco]</p> <p>Example:</p> <pre>Router(config-if)# frame-relay map ip 10.2.2.2 vc-bundle MAIN-1</pre>	<p>(Optional) Maps between a next-hop protocol address and a data-link connection identifier (DLCI) destination address, and creates a PVC bundle if it does not already exist.</p> <ul style="list-style-type: none"> The protocol-address is the destination IP address. The frame-relay map command is required for multipoint interfaces if Inverse ARP has been disabled or is not supported at the other end of the connection.
<p>Step 9 frame-relay vc-bundle <i>vc-bundle-name</i></p> <p>Example:</p> <pre>Router(config-if)# frame-relay vc- bundle MAIN-1</pre>	<p>Creates a PVC bundle if it does not already exist, and enters Frame Relay VC-bundle configuration mode.</p>
<p>Step 10 encapsulation [cisco ietf]</p> <p>Example:</p> <pre>Router(config-fr-vcb)# encapsulation ietf</pre>	<p>(Optional) Overrides the encapsulation type configured on the interface and configures the Frame Relay encapsulation type for the PVC bundle.</p> <ul style="list-style-type: none"> This command is available only when the PVC bundle is configured on a point-to-point subinterface.
<p>Step 11 match {dscp <i>dscp-value</i> precedence <i>precedence-value</i>}</p> <p>Example:</p> <pre>Router(config-fr-vcb)# match precedence 5</pre>	<p>Establishes the type of matching to use between incoming packet headers and PVC-bundle members.</p> <ul style="list-style-type: none"> The default match type is precedence.

Command or Action	Purpose
<p>Step 12 <code>pvc dci [vc-name]</code></p> <p>Example:</p> <pre>Router(config-fr-vcb)# pvc 100 1a</pre>	<p>Creates a PVC-bundle member and enters Frame Relay VC-bundle-member configuration mode.</p> <ul style="list-style-type: none"> The <code>vc-name</code> argument is an optional name that can be used for referring to the PVC.
<p>Step 13 <code>class name</code></p> <p>Example:</p> <pre>Router(config-fr-vcb-vc)# class premium</pre>	<p>(Optional) Assigns a map class to the PVC-bundle member defined in the previous step.</p>
<p>Step 14 Do one of the following:</p> <ul style="list-style-type: none"> <code>precedence {level other}</code> <code>dscp {level other}</code> <p>Example:</p> <pre>Router(config-fr-vcb-vc)# precedence 6-7</pre> <p>Example:</p> <p>Example:</p> <p>Example:</p> <pre>Router(config-fr-vcb-vc)# dscp other</pre>	<p>(Optional) Enters the mapped service level or range for the PVC-bundle member.</p> <ul style="list-style-type: none"> The <code>precedence</code> command is available when the PVC-bundle match type is set to <code>precedence</code>. The precedence range is from 0 to 7. The <code>dscp</code> command is available when the PVC-bundle match type is set to <code>dscp</code>. The <code>dscp</code> range is from 0 to 63. The <code>other</code> keyword is used to designate a PVC to handle all the remaining levels that have not been assigned to other PVCs in the bundle. Critical non-IP traffic will automatically use precedence level 0.

Command or Action	Purpose
<p>Step 15 <code>bump {explicit <i>level</i> implicit traffic}</code></p> <p>Example:</p> <pre>Router(config-fr-vcb-vc)# bump explicit 7</pre>	<p>(Optional) Specifies the bumping rule for the PVC-bundle member.</p> <ul style="list-style-type: none"> The default bumping rule is implicit bumping. Use the explicit <i>level</i> option to specify the service level to which traffic on this PVC will be bumped if the PVC goes down. In that event, the traffic will be directed to a PVC mapped with the service level configured here. If the PVC that picks up and carries the traffic also goes down, the traffic is subject to the bumping rules for that PVC. You can specify only one service level for bumping. The PVC-bundle member accepts bumped traffic by default when the PVC-bundle match type is precedence. To configure the PVC to reject bumped traffic from another PVC-bundle member, use the no bump traffic command.
<p>Step 16 <code>protect {group vc}</code></p> <p>Example:</p> <pre>Router(config-fr-vcb-vc)# protect group</pre>	<p>(Optional) Specifies the protection rule for the PVC-bundle member.</p> <ul style="list-style-type: none"> By default, the PVC-bundle member is not protected. If you use the vc keyword, the PVC bundle goes down whenever this PVC goes down. If you use the group keyword, the PVC bundle goes down when the last PVC in the protected group goes down.
<p>Step 17 <code>inarp</code></p> <p>Example:</p> <pre>Router(config-fr-vcb-vc)# inarp</pre>	<p>(Optional) Enables Inverse ARP for the PVC-bundle member.</p> <ul style="list-style-type: none"> By default, Inverse ARP traffic uses the PVC configured for precedence level 6 or DSCP level 63.
<p>Step 18 <code>end</code></p> <p>Example:</p> <pre>Router(config-fr-vcb-vc)# end</pre>	<p>Exits to privileged EXEC mode.</p>
<p>Step 19 Configure the PVC bundle on the peer router.</p>	<p>(Optional) While it is not necessary to configure a PVC bundle on the peer router, it is recommended that you do so for applications that rely on communications on the same PVC (such as TCP header-compression.)</p>

Configuring Frame Relay PVC Bundles with MPLS QoS Support

To configure Frame Relay PVC bundles for handling MPLS packets, perform the following steps:

SUMMARY STEPS

1. **enable**
2. **configure terminal**
3. **ip routing**
4. **ip cef**
5. Do one of the following:
 - **interface** *type number*
 -
 -
 -
 - **interface** {*type slot | port-adapter | port.subinterface-number*} [**multipoint** | **point-to-point**]
6. **encapsulation frame-relay** [**cisco** | **ietf**]
7. **tag-switching ip**
8. **ip address** *ip-address mask* [**secondary**]
9. **frame-relay map** *protocol protocol-address {dlci| vc-bundle vc-bundle-name}* [**broadcast**] [**ietf** | **cisco**]
10. **frame-relay vc-bundle** *vc-bundle-name*
11. **encapsulation** [**ietf** | **cisco**]
12. **pvc** *dlci* [*vc-name*]
13. **class** *name*
14. **exp** {*level* | **other**}
15. **bump** {**explicit** *level* | **implicit** | **traffic**}
16. **protect** {**group** | **vc**}
17. **inarp**
18. **end**
19. Configure the PVC bundle on the peer router.

DETAILED STEPS

	Command or Action	Purpose
Step 1	<p>enable</p> <p>Example:</p> <pre>Router> enable</pre>	<p>Enables privileged EXEC mode.</p> <ul style="list-style-type: none"> • Enter your password if prompted.
Step 2	<p>configure terminal</p> <p>Example:</p> <pre>Router# configure terminal</pre>	<p>Enters global configuration mode.</p>

Command or Action	Purpose
<p>Step 3 ip routing</p> <p>Example:</p> <pre>Router(config)# ip routing</pre>	<p>Enables IP routing.</p>
<p>Step 4 ip cef</p> <p>Example:</p> <pre>Router(config)# ip cef</pre>	<p>Enables Cisco Express Forwarding.</p> <p>Note For the Cisco 7500, enter ip cef distributed.</p>
<p>Step 5 Do one of the following:</p> <ul style="list-style-type: none"> • interface <i>type number</i> • • • interface {<i>type slot port-adapter port.subinterface-number</i>} [multipoint point-to-point] <p>Example:</p> <pre>Router(config)# interface serial 0</pre> <p>Example:</p> <p>Example:</p> <p>Example:</p> <pre>Router(config)# interface serial 1.1 multipoint</pre>	<p>Specifies the interface type and number and enters interface configuration mode.</p> <ul style="list-style-type: none"> • Physical interfaces are multipoint subinterfaces by default. <p>or</p> <p>Specifies the interface type and subinterface and enters subinterface configuration mode.</p> <ul style="list-style-type: none"> • Once you create a specific type of subinterface (point-to-point or multipoint), you cannot change it without a reload. To change it, you need to either reload the router or create another subinterface.

	Command or Action	Purpose
Step 6	<p>encapsulation frame-relay [cisco ietf]</p> <p>Example:</p> <pre>Router(config-if)# encapsulation frame-relay</pre>	<p>Enables Frame Relay encapsulation.</p> <ul style="list-style-type: none"> The default encapsulation method is cisco.
Step 7	<p>tag-switching ip</p> <p>Example:</p> <pre>Router(config-if)# tag-switching ip</pre>	<p>Enables label switching of IPv4 packets on an interface.</p>
Step 8	<p>ip address ip-address mask [secondary]</p> <p>Example:</p> <pre>Router(config-if)# ip address 10.1.1.1 255.0.0.0</pre>	<p>Sets a primary IP address for the interface.</p> <ul style="list-style-type: none"> The optional secondary keyword specifies that the configured address is a secondary IP address. If this keyword is omitted, the configured address is the primary IP address.
Step 9	<p>frame-relay map protocol protocol-address {dlci vc-bundle vc-bundle-name} [broadcast] [ietf cisco]</p> <p>Example:</p> <pre>Router(config-if)# frame-relay map ip 10.2.2.2 vc-bundle MAIN-1</pre>	<p>(Optional) Maps between a next-hop protocol address and a DLCI destination address, and creates a PVC bundle if it does not already exist.</p> <ul style="list-style-type: none"> The protocol-address is the destination IP address. The frame-relay map command is required for multipoint interfaces if Inverse ARP has been disabled or is not supported at the other end of the connection.
Step 10	<p>frame-relay vc-bundle vc-bundle-name</p> <p>Example:</p> <pre>Router(config-if)# frame-relay vc-bundle MAIN-1</pre>	<p>Creates a PVC bundle if it does not already exist, and enters Frame Relay VC-bundle configuration mode.</p>
Step 11	<p>encapsulation [ietf cisco]</p> <p>Example:</p> <pre>Router(config-fr-vcb)# encapsulation ietf</pre>	<p>(Optional) Overrides the encapsulation type configured on the interface and configures the Frame Relay encapsulation type for the PVC bundle.</p> <ul style="list-style-type: none"> This command is available only when the PVC bundle is configured on a point-to-point subinterface.

Command or Action	Purpose
<p>Step 12 <code>pvc dlcI [vc-name]</code></p> <p>Example:</p> <pre>Router(config-fr-vcb)# pvc 100 1a</pre>	<p>Creates a PVC-bundle member and enters Frame Relay VC-bundle-member configuration mode.</p> <ul style="list-style-type: none"> The <i>vc-name</i> argument is an optional name that can be used for referring to the PVC.
<p>Step 13 <code>class name</code></p> <p>Example:</p> <pre>Router(config-fr-vcb-vc)# class premium</pre>	<p>(Optional) Assigns a map class to the PVC-bundle member.</p>
<p>Step 14 <code>exp {level other}</code></p> <p>Example:</p> <pre>Router(config-fr-vcb-vc)# exp 6-7</pre>	<p>(Optional) Enters the mapped EXP level or range for the PVC-bundle member.</p> <ul style="list-style-type: none"> The exp command is available only when tag-switching has been enabled. The EXP level values are from 0 to 7. The other keyword is used to designate a PVC to handle all the remaining levels that have not been assigned to other PVCs in the bundle.
<p>Step 15 <code>bump {explicit level implicit traffic}</code></p> <p>Example:</p> <pre>Router(config-fr-vcb-vc)# bump explicit 7</pre>	<p>(Optional) Specifies the bumping rule for the PVC-bundle member defined above.</p> <ul style="list-style-type: none"> The default bumping rule is implicit bumping. Use the explicit level option to specify the EXP level to which traffic on this PVC will be bumped if the PVC goes down. In that event, the traffic will be directed to a PVC mapped with the EXP level configured here. If the PVC that picks up and carries the traffic also goes down, the traffic is subject to the bumping rules for that PVC. You can specify only one EXP level for bumping. To configure the PVC to reject bumped traffic from another PVC-bundle member, use the no bump traffic command.
<p>Step 16 <code>protect {group vc}</code></p> <p>Example:</p> <pre>Router(config-fr-vcb-vc)# protect group</pre>	<p>(Optional) Specifies the protection rule for the PVC-bundle member defined above.</p> <ul style="list-style-type: none"> By default, the PVC-bundle member is not protected. If you use the vc keyword, the PVC bundle goes down whenever this PVC goes down. If you use the group keyword, the PVC bundle goes down when the last PVC in the protected group goes down.

Command or Action	Purpose
Step 17 inarp Example: <pre>Router(config-fr-vcb-vc)# inarp</pre>	(Optional) Enables Inverse ARP for the PVC-bundle member defined above. <ul style="list-style-type: none"> By default, Inverse ARP traffic uses the PVC configured for EXP level 6.
Step 18 end Example: <pre>Router(config-fr-vcb-vc)# end</pre>	(Optional) Exits to privileged EXEC mode.
Step 19 Configure the PVC bundle on the peer router.	(Optional) While it is not necessary to configure a PVC bundle on the peer router, it is recommended that you do so for applications that rely on communications on the same PVC (such as TCP header-compression.)

Verifying Frame Relay PVC Bundles Configuration

To verify the configuration and operation of Frame Relay PVC bundles with QoS support, perform the following optional steps:

SUMMARY STEPS

- enable
- show frame-relay vc-bundle *vc-bundle-name* [detail]
- show frame-relay map
- show frame-relay pvc
- show frame-relay ip rtp header-compression [interface *type number*]
- show frame-relay ip tcp header-compression [interface *type number*]
- show adjacency [*type number*] [detail] [summary]

DETAILED STEPS

Command or Action	Purpose
Step 1 enable Example: <pre>Router> enable</pre>	Enables privileged EXEC mode. <ul style="list-style-type: none"> Enter your password if prompted.

Command or Action	Purpose
<p>Step 2 <code>show frame-relay vc-bundle <i>vc-bundle-name</i> [detail]</code></p> <p>Example:</p> <pre>Router# show frame-relay vc-bundle mp-3-static</pre>	Displays status, bumping information, protection information, and active and configured precedence or DSCP levels for the PVCs in a PVC bundle.
<p>Step 3 <code>show frame-relay map</code></p> <p>Example:</p> <pre>Router# show frame-relay map</pre>	Displays the current Frame Relay map entries and information about the connections.
<p>Step 4 <code>show frame-relay pvc</code></p> <p>Example:</p> <pre>Router# show frame-relay pvc</pre>	Displays PVC statistics for the PVC-bundle members.
<p>Step 5 <code>show frame-relay ip rtp header-compression [interface <i>type number</i>]</code></p> <p>Example:</p> <pre>Router# show frame-relay ip rtp header-compression</pre>	Displays Frame Relay Real-Time Transport Protocol (RTP) header compression statistics for PVC bundles.
<p>Step 6 <code>show frame-relay ip tcp header-compression [interface <i>type number</i>]</code></p> <p>Example:</p> <pre>Router# show frame-relay ip tcp header-compression serial 1/4</pre>	Displays Frame Relay TCP/IP header compression statistics for PVC bundles.
<p>Step 7 <code>show adjacency [<i>type number</i>] [detail] [summary]</code></p> <p>Example:</p> <pre>Router# show adjacency</pre>	Displays Cisco Express Forwarding adjacency table information.

Monitoring and Maintaining Frame Relay PVC Bundles

To monitor and maintain Frame Relay PVC bundles, perform this task.

SUMMARY STEPS

1. **enable**
2. **debug frame-relay adjacency** {pvc[*dldci*] | vc-bundle [*vc-bundle-name*]}
3. **debug frame-relay vc-bundle** {detail | state-change} [*vc-bundle-name*]

DETAILED STEPS

	Command or Action	Purpose
Step 1	enable Example: Router> enable	Enables higher privilege levels, such as privileged EXEC mode. <ul style="list-style-type: none"> • Enter your password if prompted.
Step 2	debug frame-relay adjacency {pvc[<i>dldci</i>] vc-bundle [<i>vc-bundle-name</i>] } Example: Router# debug frame-relay adjacency pvc	Displays information pertaining to an adjacent node that has one or more Frame Relay PVCs or PVC bundles. <ul style="list-style-type: none"> • Use this command to monitor adjacency activity.
Step 3	debug frame-relay vc-bundle {detail state-change} [<i>vc-bundle-name</i>] Example: Router# debug frame-relay vc-bundle state-change	Displays information about the Frame Relay PVC bundles configured on a router. <ul style="list-style-type: none"> • Use this command to monitor state changes and Inverse ARP activity for one or all of the PVC bundles and bundle members configured on a router. <p>Note Using the detail keyword generates a large number of debugs that can quickly fill up a log buffer.</p>

Configuration Examples for Frame Relay PVC Bundles with QoS Support for IP and MPLS

- [PVC Bundles with IP QoS Support on Interfaces Example, page 149](#)
- [PVC Bundle with IP QoS Support with Multiple QoS Parameters Example, page 151](#)
- [PVC Bundle with MPLS QoS Support Example, page 151](#)
- [Verifying Frame Relay PVC Bundle Configuration Examples, page 152](#)
- [Monitoring and Maintaining Frame Relay PVC Bundles Examples, page 154](#)

PVC Bundles with IP QoS Support on Interfaces Example

The following example shows the configuration of five PVC bundles with IP precedence and DSCP mapping. Two bundles are configured on the main interface, one bundle with static mapping and one with

dynamic mapping. Two bundles are configured on a multipoint subinterface, one bundle with static mapping and one with dynamic mapping. One bundle is configured on a point-to-point subinterface.

```

configure terminal
ip routing
ip cef
interface Serial 1/4
  encapsulation frame-relay
  frame-relay intf-type dte
  ip address 10.1.1.1 255.0.0.0
  frame-relay map ip 192.168.2.2 vc-bundle MAIN-1-static
  frame-relay vc-bundle MAIN-1-static
  match precedence
  pvc 100 1a
  precedence other
  pvc 101 1b
  precedence 1
  pvc 102 1c
  precedence 2
  pvc 103 1d
  precedence 3
  pvc 104 1e
  precedence 4
  pvc 105 1f
  precedence 5
  pvc 106 1g
  precedence 6
  pvc 107 1h
  frame-relay vc-bundle MAIN-2-dynamic
  match precedence
  pvc 200
  precedence 0
  pvc 201
  precedence 1
  pvc 202
  precedence 2
  pvc 203
  precedence 3
  pvc 204
  precedence 4
  pvc 205
  precedence 5
  pvc 206
  precedence 6
  pvc 207
  precedence 7
interface Serial 1/4.1 multipoint
  ip address 172.16.1.1 255.0.0.0
  frame-relay map ip 172.17.2.2 vc-bundle MP-3-static
  frame-relay vc-bundle MP-3-static
  match precedence
  pvc 300 3a
  precedence 0
  pvc 301 3b
  precedence 1
  pvc 302 3c
  precedence 2
  pvc 303 3d
  precedence 3
  pvc 304 3e
  precedence 4
  pvc 305 3f
  precedence 5
  pvc 306 3g
  precedence 6
  pvc 307 3h
  precedence 7
interface Serial 1/4.1 multipoint
  frame-relay vc-bundle MP-4-dynamic
  match precedence
  match dscp
  pvc 400 4a

```

```

dscp other
pvc 401 4b
dscp 10-19
pvc 402 4c
dscp 20-29
pvc 403 4d
dscp 30-39
pvc 404 4e
dscp 40-49
pvc 405 4f
dscp 50-59
pvc 406 4g
dscp 60-62
pvc 407 4h
dscp 63
end
interface Serial 1/4.2 point-to-point
ip address 192.168.2.1 255.0.0.0
frame-relay vc-bundle P2P-5
match precedence
pvc 500 5a
precedence 0
pvc 501 5b
precedence 1
pvc 502 5c
precedence 2
pvc 503 5d
precedence 3
pvc 504 5e
precedence 4
pvc 505 5f
precedence 5
pvc 506 5g
precedence 6
pvc 507 5h
precedence 7

```

PVC Bundle with IP QoS Support with Multiple QoS Parameters Example

The following example shows the configuration of a Frame Relay PVC bundle with DSCP-based mapping. The bundle member PVCs are configured with bumping, protection, and other parameters.

```

interface Serial 1/4.2 point-to-point
frame-relay vc-bundle BUNDLE-SEFEN
encapsulation ietf
match dscp
pvc 301
dscp other
bump explicit 45
protect group
class CIR-64000
pvc 302
dscp 40-49
bump explicit 20
no bump traffic
protect vc
inarp
pvc 303
dscp 30-39
bump implicit
protect group

```

PVC Bundle with MPLS QoS Support Example

The following example shows the configuration of four Frame Relay PVC bundle members with MPLS EXP level support in the PVC bundle named "user1".

```

interface serial 0.1 point-to-point

```

```

encapsulation frame-relay
ip address 10.1.1.1
tag-switching ip
frame-relay vc-bundle user1
pvc 100 ny-control
class control
exp 7
protect vc
pvc 101 ny-premium
class premium
exp 6-5
bump explicit 7
no bump traffic
protect group
pvc 102 my-priority
class priority
exp 4-2
protect group
pvc 103 ny-basic
class basic
exp other

protect group

```

Verifying Frame Relay PVC Bundle Configuration Examples

The following examples show output for the commands that can be used to verify Frame Relay PVC bundle configuration.

Sample Output for the show frame-relay vc-bundle Command

The following example shows the Frame Relay PVC bundle named "MP-4-dynamic" with PVC protection applied. Note that in this PVC bundle, DLCI 400 is configured to bump traffic explicitly to the PVC that handles DSCP level 40, which is DLCI 404. All the other DLCIs are configured for implicit bumping. In addition, all the DLCIs are configured to accept bumped traffic.

The asterisk (*) before PVC 4a indicates that this PVC was configured with the **precedence other** command, which means the PVC will handle all levels that are not explicitly configured on other PVCs.

In this example all PVCs are up so the values in the "Active level" fields match the values in the "Config level" fields. If a PVC goes down and its traffic is bumped, the "Active level" field value for the PVC that went down is cleared. The "Active level" field values for the PVC that the traffic bumped to will be updated to include the levels of the PVC that went down.

The first three PVCs in the following example make up a protected group. All three of these PVCs must go down before the bundle will go down. The last two PVCs are protected PVCs: if either of these PVCs go down, the bundle will go down.

```

Router# show frame-relay vc-bundle MP-4-dynamic
MP-4-dynamic on Serial 1/4.1 - Status: UP Match-type: DSCP
Name      DLCI      Config.   Active   Bumping
PG/      CIR      Status
level   level
*4a      400      0-9      0-9      to/accept
up      40/Yes   PG      kbps
4b      401      10-19    10-19    9/Yes
pg      up
4c      402      20-29    20-29    19/Yes
pg      up
4d      403      30-39    30-39    29/Yes
-      up
4e      404      40-49    40-49    39/Yes
-      up
4f      405      50-59    50-59    49/Yes
-      up
4g      406      60-62    60-62    59/Yes

```



```

pv          up
4h          407      63      63      62/Yes      pv          up
Packets sent out on vc-bundle MP-4-dynamic : 0:
Router#

```

The following example shows the detail output of a PVC bundle. Note in this example that because all packet service levels are not handled, and because the PVCs are currently down, this bundle can never come up.

```

Router# show frame-relay vc-bundle x41 detail
x41 on Serial1/1 - Status: DOWN Match-type: DSCP
Name          DLCI      Config.      Active          Bumping
PG/          CIR      Status
level      level      to/accept      PV      kbps
          410      50-62      49/Yes      -      down
          411      30,32,34,36,3.. 29/Yes
-          down
Packets sent out on vc-bundle x41 : 0
Active configuration and statistics for each member PVC
DLCI      Output pkts      Active level
410      0      50-62
411      0      30,32,34,36,38-40
Router#

```

Sample Output for the show frame-relay map Command

The following sample output displays map and connection information for a PVC bundle called "MAIN-1-static":

```

Router# show frame-relay map
Serial1/4 (up):ip 10.2.2.2 vc-bundle MAIN-1-static, static,
             CISCO, status up

```

Sample Output for the show frame-relay pvc Command

The following sample output indicates that PVC 202 is a member of VC bundle "MAIN-1-static":

```

Router# show frame-relay pvc 202
PVC Statistics for interface Serial1/4 (Frame Relay DTE)
DLCI = 202, DLCI USAGE = LOCAL, PVC STATUS = STATIC, INTERFACE = Serial1/4
  input pkts 0          output pkts 45          in bytes 0
  out bytes 45000      dropped pkts 0          in FECN pkts 0
  in BECN pkts 0      out FECN pkts 0        out BECN pkts 0
  in DE pkts 0         out DE pkts 0
  out bcast pkts 0     out bcast bytes 0
  5 minute input rate 0 bits/sec, 0 packets/sec
  5 minute output rate 2000 bits/sec, 2 packets/sec
  pvc create time 00:01:25, last time pvc status changed 00:01:11
  VC-Bundle MAIN-1-static

```

Sample Output for the show adjacency Command

The following is sample output for the **show adjacency** command for a PVC bundle configured on serial subinterface 1/4.1. Each bundle member is listed. The bundle itself is indicated by "incomplete" because no traffic actually transmitted on that entry.

```

Router# show adjacency
Protocol Interface      Address
IP       Serial1/4.1        10.2.2.2(4)
IP       Serial1/4.1        10.2.2.2(4)
IP       Serial1/4.1        10.2.2.2(4)
IP       Serial1/4.1        10.2.2.2(4)
IP       Serial1/4.1        10.2.2.2(4)
IP       Serial1/4.1        10.2.2.2(4)
IP       Serial1/4.1        10.2.2.2(4)

```

```

IP      Serial1/4.1      10.2.2.2(4)
IP      Serial1/4.1      10.2.2.2(5) (incomplete)

```

Monitoring and Maintaining Frame Relay PVC Bundles Examples

The following examples show output for the **debug frame-relay adjacency** and **debug frame-relay vc-bundle** commands, which can be used to troubleshoot Frame Relay PVC bundle operation. "FR-VCB" indicates output from the **debug frame-relay vc-bundle** command, and "FR-ADJ" indicates output from the **debug frame-relay adjacency** command.



Note

Debug messages that are prefixed with "FR_ADJ" (instead of FR-ADJ) or "FR_VCB" (instead of "FR-VCB") indicate serious failures in the Frame Relay PVC bundle performance. Contact the Cisco Technical Assistance Center (TAC) if you see debug messages with these prefixes.

The following is sample output that shows a PVC bundle that uses static map coming up. PVC bundle member 100 comes up first, then the PVC bundle itself can come up.

```

Router# debug frame-relay vc-bundle state-change
Router# debug frame-relay adjacency vc-bundle

00:35:58:FR-VCB:MAIN-1-static:member 100 state changed to UP 00:35:58:FR-VCB:MAIN-1-
static:state changed to UP
00:35:58:FR-ADJ:vcb MAIN-1-static:ip 10.2.2.2:adding primary adj
00:35:58:FR-ADJ:vcb MAIN-1-static:member 100:adding adj
00:35:58:FR-ADJ:vcb MAIN-1-static:member 100:locking adj at index 0 00:35:58:FR-ADJ:vcb
MAIN-1-static:member 100:locking adj at index 1
00:35:58:FR-ADJ:vcb MAIN-1-static:member 100:locking adj at index 2
00:35:58:FR-ADJ:vcb MAIN-1-static:member 100:locking adj at index 3
00:35:58:FR-ADJ:vcb MAIN-1-static:member 100:locking adj at index 4
00:35:58:FR-ADJ:vcb MAIN-1-static:member 100:locking adj at index 5
00:35:58:FR-ADJ:vcb MAIN-1-static:member 100:locking adj at index 6
00:35:58:FR-ADJ:vcb MAIN-1-static:member 100:locking adj at index 7
00:35:58:%FR-5-DLCICHANGE:Interface Serial1/4 - DLCI 100 state changed to ACTIVE
00:35:58:FR-VCB:MAIN-1-static:member 101 state changed to UP
00:35:58:FR-ADJ:vcb MAIN-1-static:ip 10.2.2.2:updating primary adj
00:35:58:FR-ADJ:vcb MAIN-1-static:member 100:updating adj
00:35:58:FR-ADJ:vcb MAIN-1-static:member 101:adding adj
00:35:58:FR-ADJ:vcb MAIN-1-static:member 100:unlocking adj at index 1
00:35:58:FR-ADJ:vcb MAIN-1-static:member 101:locking adj at index 1

```

The following is sample output that shows a PVC bundle going down. Each bundle member PVC is marked for removal from Cisco Express Forwarding adjacency table, and then the adjacency for the PVC bundle itself is marked for removal. The adjacencies are actually removed from the table later when a background clean-up process runs.

```

00:38:35:FR-VCB:MP-3-static:state changed to DOWN
00:38:35:FR-ADJ:vcb MP-3-static:ip 172.17.2.2:member 300:removing adj
00:38:35:FR-ADJ:vcb MP-3-static:ip 172.17.2.2:member 301:removing adj
00:38:35:FR-ADJ:vcb MP-3-static:ip 172.17.2.2:member 302:removing adj
00:38:35:FR-ADJ:vcb MP-3-static:ip 172.17.2.2:member 303:removing adj
00:38:35:FR-ADJ:vcb MP-3-static:ip 172.17.2.2:member 304:removing adj
00:38:35:FR-ADJ:vcb MP-3-static:ip 172.17.2.2:member 305:removing adj
00:38:35:FR-ADJ:vcb MP-3-static:ip 172.17.2.2:removing primary adj

```

The following is sample output that shows Inverse ARP information for the PVC bundle. PVC bundle member 406 is the only PVC in the bundle to handle Inverse ARP packets. The Inverse ARP packets coming in on other bundle member PVCs are dropped.

```

00:23:48:FR-VCB:MP-4-dynamic:inarp received on elected member 406
00:23:48:FR-VCB:MP-4-dynamic:installing dynamic map

```

```
00:23:48:FR-VCB:MP-4-dynamic:dropping inarp received on member 407
00:23:52:FR-VCB:MP-4-dynamic:sending inarp pkt on member 406
```

In the following example the PVC bundle goes down because the protected group goes down. All information about active transmission on each PVC is removed.

```
00:58:27:FR-VCB:MP-4-dynamic:member 402 state changed to DOWN
00:58:27:FR-VCB:MP-4-dynamic:protected group is DOWN
00:58:27:FR-VCB:MP-4-dynamic:state changed to DOWN
00:58:27:FR-VCB:MP-4-dynamic:active table reset
```

Additional References

Related Documents

Related Topic	Document Title
Frame Relay configuration tasks	<i>"Configuring Frame Relay chapter in the Cisco IOS Wide-Area Networking Configuration Guide , Release 12.2</i>
Frame Relay commands	<i>"Frame Relay Commands chapter in the Cisco IOS Wide-Area Networking Command Reference , Release 12.2</i>
Frame Relay PVC interface priority queueing configuration tasks	<i>"Configuring Weighted Fair Queueing " section in the Congestion Management chapter in the Cisco IOS Quality of Service Configuration Guide , Release 12.2</i>

Standards

Standards	Title
None	--

MIBs

MIBs	MIBs Link
None	To locate and download MIBs for selected platforms, Cisco IOS releases, and feature sets, use Cisco MIB Locator found at the following URL: http://www.cisco.com/go/mibs

RFCs

RFCs	Title
None	--

Technical Assistance

Description	Link
The Cisco Technical Support & Documentation website contains thousands of pages of searchable technical content, including links to products, technologies, solutions, technical tips, and tools. Registered Cisco.com users can log in from this page to access even more content.	http://www.cisco.com/techsupport

Feature Information for Frame Relay PVC Bundles with QoS Support for IP and MPLS

The following table provides release information about the feature or features described in this module. This table lists only the software release that introduced support for a given feature in a given software release train. Unless noted otherwise, subsequent releases of that software release train also support that feature.

Use Cisco Feature Navigator to find information about platform support and Cisco software image support. To access Cisco Feature Navigator, go to www.cisco.com/go/cfn. An account on Cisco.com is not required.

Table 5 Feature Information for Frame Relay PVC Bundles with QoS Support for IP and MPLS

Feature Name	Releases	Feature Information
Frame Relay VC Bundling	12.2(13)T 12.2(28)SB 15.0(1)S	<p>Frame Relay permanent virtual circuit (PVC) bundle functionality allows you to associate a group of Frame Relay PVCs with a single next-hop address.</p> <p>The following commands were introduced or modified: bump (Frame Relay VC-bundle-member), class, debug frame-relay adjacency, debug frame-relay vc-bundle, dscp (Frame Relay VC-bundle-member), encapsulation (Frame Relay VC-bundle), exp, frame-relay inverse-arp, frame-relay map, frame-relay vc-bundle, inarp (Frame Relay VC-bundle-member), match, precedence (Frame Relay VC-bundle-member), protect (Frame Relay VC-bundle-member), pvc (Frame Relay VC-bundle), show frame-relay ip rtp header-compression, show frame-relay ip tcp header-compression, show frame-relay map, show frame-relay pvc, show frame-relay vc-bundle..</p>

Glossary

DLCI --data-link connection identifier. Value that specifies a permanent virtual circuit (PVC) or switched virtual circuit (SVC) in a Frame Relay network.

FIFO queueing -- First-in, first-out queueing. FIFO involves buffering and forwarding of packets in the order of arrival. FIFO embodies no concept of priority or classes of traffic. There is only one queue, and all packets are treated equally. Packets are sent out an interface in the order in which they arrive.

Frame Relay traffic shaping --See FRTS.

FRF.12 --The FRF.12 Implementation Agreement was developed to allow long data frames to be fragmented into smaller pieces and interleaved with real-time frames. In this way, real-time voice and nonreal-time data frames can be carried together on lower-speed links without causing excessive delay to the real-time traffic.

FRTS --Frame Relay traffic shaping. FRTS uses queues on a Frame Relay network to limit surges that can cause congestion. Data is buffered and then sent into the network in regulated amounts to ensure that the traffic will fit within the promised traffic envelope for the particular connection.

PIPQ --Permanent virtual circuit (PVC) interface priority queueing. An interface-level priority queueing scheme in which prioritization is based on destination PVC rather than packet contents.

quality of service --Measure of performance for a transmission system that reflects its transmission quality and service availability.

VoFR --Voice over Frame Relay. Enables a router to carry voice traffic over a Frame Relay network. When voice traffic is sent over Frame Relay, the voice traffic is segmented and encapsulated for transit across the Frame Relay network using FRF.12 encapsulation.

Voice over Frame Relay --See VoFR.

WFQ --weighted fair queueing. Congestion management algorithm that identifies conversations (in the form of traffic streams), separates packets that belong to each conversation, and ensures that capacity is shared fairly among these individual conversations. WFQ is an automatic way of stabilizing network behavior during congestion and results in increased performance and reduced retransmission.

WRED --Weighted Random Early Detection. Combines IP Precedence and standard Random Early Detection (RED) to allow for preferential handling of voice traffic under congestion conditions without exacerbating the congestion. WRED uses and interprets IP Precedence to give priority to voice traffic over data traffic, dropping only data packets.

Cisco and the Cisco Logo are trademarks of Cisco Systems, Inc. and/or its affiliates in the U.S. and other countries. A listing of Cisco's trademarks can be found at www.cisco.com/go/trademarks. Third party trademarks mentioned are the property of their respective owners. The use of the word partner does not imply a partnership relationship between Cisco and any other company. (1005R)

Any Internet Protocol (IP) addresses and phone numbers used in this document are not intended to be actual addresses and phone numbers. Any examples, command display output, network topology diagrams, and other figures included in the document are shown for illustrative purposes only. Any use of actual IP addresses or phone numbers in illustrative content is unintentional and coincidental.



Frame Relay Voice-Adaptive Traffic Shaping and Fragmentation

The Frame Relay Voice-Adaptive Traffic Shaping and Fragmentation feature helps ensure voice quality by adjusting the rate of traffic and activating fragmentation on the basis of the presence of voice on the permanent virtual circuit (PVC). Frame Relay voice-adaptive traffic shaping enables a PVC to adjust the rate of traffic if packets are detected in the priority queue or if H.323 call setup signaling packets are detected. Frame Relay voice-adaptive fragmentation allows fragmentation to be activated when priority-queue or H.323 signaling packets are detected. When priority-queue traffic and signaling packets are not present, Frame Relay voice-adaptive fragmentation allows fragmentation to be deactivated.

Feature Specifications for Frame Relay Voice-Adaptive Traffic Shaping and Fragmentation

Feature History

Release	Modification
12.2(15)T	This feature was introduced.

Supported Platforms

Cisco 1700 series, Cisco 2600 series, Cisco 3600 series, Cisco 3700 series, Cisco 4500, Cisco 7200 series, Cisco 7400 series, Cisco 7500 series (without Versatile Interface Processor.)

- [Finding Feature Information, page 159](#)
- [Prerequisites for Frame Relay Voice-Adaptive Traffic Shaping and Fragmentation, page 160](#)
- [Restrictions for Frame Relay Voice-Adaptive Traffic Shaping and Fragmentation, page 160](#)
- [Information About Frame Relay Voice-Adaptive Traffic Shaping and Fragmentation, page 160](#)
- [How to Configure Frame Relay Voice-Adaptive Traffic Shaping and Fragmentation, page 161](#)
- [Configuration Examples for Frame Relay Voice-Adaptive Traffic Shaping and Fragmentation, page 169](#)
- [Additional References, page 172](#)

Finding Feature Information

Your software release may not support all the features documented in this module. For the latest feature information and caveats, see the release notes for your platform and software release. To find information

about the features documented in this module, and to see a list of the releases in which each feature is supported, see the Feature Information Table at the end of this document.

Use Cisco Feature Navigator to find information about platform support and Cisco software image support. To access Cisco Feature Navigator, go to www.cisco.com/go/cfn. An account on Cisco.com is not required.

Prerequisites for Frame Relay Voice-Adaptive Traffic Shaping and Fragmentation

Prerequisites for Frame Relay Voice-Adaptive Traffic Shaping

- Traffic shaping and low latency queueing must be configured using the Modular QoS CLI (MQC).

Prerequisites for Frame Relay Voice-Adaptive Fragmentation

- End-to-end fragmentation must be configured in a map class or on the interface.
- Frame Relay traffic shaping or traffic shaping using the MQC must be configured. If end-to-end fragmentation is configured on the interface, traffic shaping must be configured using the MQC.
- Low latency queueing must be configured.
- End-to-end fragmentation must be configured on the peer router. Although the peer router may not see the expected fragmented packets from the router doing voice-adaptive fragmentation, the peer will be able to handle large unfragmented packets in addition to fragmented packets.

Restrictions for Frame Relay Voice-Adaptive Traffic Shaping and Fragmentation

The feature supports FRF.12 fragmentation only. Neither FRF.11 Annex C nor Cisco proprietary fragmentation is supported.

Information About Frame Relay Voice-Adaptive Traffic Shaping and Fragmentation

- [Benefits of Frame Relay Voice-Adaptive Traffic Shaping and Fragmentation, page 160](#)
- [Frame Relay Voice-Adaptive Traffic Shaping, page 161](#)
- [Frame Relay Voice-Adaptive Fragmentation, page 161](#)

Benefits of Frame Relay Voice-Adaptive Traffic Shaping and Fragmentation

Before the introduction of this new feature, Frame Relay adaptive shaping could be used to reduce the sending rate when a network was congested. Because the adaptive shaping mechanism was triggered by network congestion, voice traffic might already have been delayed by the time the sending rate was reduced. The Frame Relay Voice-Adaptive Traffic Shaping and Fragmentation feature helps to ensure voice quality by adjusting the rate of traffic based on the presence of voice on the PVC.

Frame Relay voice-adaptive traffic shaping and fragmentation

- Prevents delay of voice packets when network congestion occurs by reducing the traffic rate to the minimum committed information rate (minCIR) and turning on fragmentation when voice packets are present on a PVC.
- Maximizes utilization of the PVC by increasing the traffic rate to committed information rate (CIR) when voice packets are not present.
- Reduces CPU utilization by turning off fragmentation when there are no voice packets present.

Frame Relay Voice-Adaptive Traffic Shaping

Frame Relay voice-adaptive traffic shaping enables a router to reduce the PVC sending rate to the minCIR whenever packets (usually voice) are detected in the low latency queueing priority queue or H.323 call setup signaling packets are present. When there are no packets in the priority queue and signaling packets are not present for a configured period of time, the router increases the PVC sending rate from minCIR to CIR to maximize throughput.



Note

Although the priority queue is generally used for voice traffic, Frame Relay voice-adaptive traffic shaping will respond to any packets (voice or data) in the priority queue.

Frame Relay voice-adaptive traffic shaping can be used at the same time as other types of adaptive traffic shaping. For example, if both Frame Relay voice-adaptive traffic shaping and adaptive shaping based on interface congestion are configured, the router will reduce the sending rate to minCIR if there are packets in the priority queue or the interface queue size exceeds the configured threshold.

Frame Relay voice-adaptive traffic shaping can be used in conjunction with or independently of voice-adaptive fragmentation.

Frame Relay Voice-Adaptive Fragmentation

Frame Relay voice-adaptive fragmentation enables a router to fragment large data packets whenever packets (usually voice) are detected in the low latency queueing priority queue or H.323 call setup signaling packets are present. When there are no packets in the priority queue for a configured period of time and signaling packets are not present, fragmentation is stopped.



Note

Although the priority queue is generally used for voice traffic, Frame Relay voice-adaptive fragmentation will respond to any packets (voice or data) in the priority queue.

Frame Relay voice-adaptive fragmentation can be used in conjunction with or independent of voice-adaptive traffic shaping.

To use voice-adaptive fragmentation, you must also have end-to-end fragmentation configured in a map class or on the interface.

How to Configure Frame Relay Voice-Adaptive Traffic Shaping and Fragmentation

The following tasks enable both Frame Relay voice-adaptive traffic shaping and fragmentation. The features can also be used separately. If you choose to use voice-adaptive fragmentation by itself, you can

configure either MQC traffic shaping (as in the tasks that follow) or Frame Relay traffic shaping. If you use Frame Relay traffic shaping, end-to-end fragmentation must be configured in a map class.

- [Configuring Class Policy for the Priority Queue and Bandwidth Queues](#), page 162
- [Configuring Frame Relay Voice-Adaptive Traffic Shaping Using the Class-Default Class](#), page 163
- [Configuring a Map Class for Frame Relay Voice-Adaptive Traffic Shaping and Fragmentation](#), page 165
- [Enabling Frame Relay Voice-Adaptive Traffic Shaping and Fragmentation on the Interface](#), page 166
- [Verifying Frame Relay Voice-Adaptive Traffic Shaping and Fragmentation](#), page 168

Configuring Class Policy for the Priority Queue and Bandwidth Queues

Perform this task to configure a policy map for the priority class and other classes.

SUMMARY STEPS

1. **enable**
2. **configure terminal**
3. **policy-map** *policy-map*
4. **class** *class-name*
5. **priority** *bandwidth-kbps*
6. **exit**
7. **class** *class-name*
8. **bandwidth** *bandwidth-kbps*
9. **end**

DETAILED STEPS

	Command or Action	Purpose
Step 1	enable Example: Router> enable	Enables privileged EXEC mode. <ul style="list-style-type: none"> • Enter your password if prompted.
Step 2	configure terminal Example: Router# configure terminal	Enters global configuration mode.
Step 3	policy-map <i>policy-map</i> Example: Router(config)# policy-map FR-VATS	Specifies the name of the policy map to be created or modified. <ul style="list-style-type: none"> • Use this command to define the queuing policy for the priority queue.

Command or Action	Purpose
<p>Step 4 <code>class class-name</code></p> <p>Example:</p> <pre>Router(config-pmap)# class VOICE</pre>	<p>Specifies the name of a class to be created and included in the service policy.</p> <ul style="list-style-type: none"> The class name that you specify in the policy map defines the characteristics for that class and its match criteria as configured using the class-map command.
<p>Step 5 <code>priority bandwidth-kbps</code></p> <p>Example:</p> <pre>Router(config-pmap-c)# priority 10</pre>	<p>Creates a strict priority class and specifies the amount of bandwidth, in kbps, to be assigned to the class.</p>
<p>Step 6 <code>exit</code></p> <p>Example:</p> <pre>Router(config-pmap-c)# exit</pre>	<p>Returns to policy map configuration mode.</p>
<p>Step 7 <code>class class-name</code></p> <p>Example:</p> <pre>Router(config-pmap)# class DATA</pre>	<p>Specifies the name of a class to be created and included in the service policy.</p> <ul style="list-style-type: none"> The class name that you specify in the policy map defines the characteristics for that class and its match criteria as configured using the class-map command.
<p>Step 8 <code>bandwidth bandwidth-kbps</code></p> <p>Example:</p> <pre>Router(config-pmap-c)# bandwidth 10</pre>	<p>Specifies the amount of bandwidth to be assigned to the class, in kbps or as a percentage of the available bandwidth. Bandwidth must be specified in kbps or as a percentage consistently across classes. (Bandwidth of the priority queue must be specified in kbps.)</p>
<p>Step 9 <code>end</code></p> <p>Example:</p> <pre>Router(config-pmap-c)# end</pre>	<p>Exits to privileged EXEC mode.</p>

Configuring Frame Relay Voice-Adaptive Traffic Shaping Using the Class-Default Class

Perform the following task to configure the shaping policy, including Frame Relay voice-adaptive traffic shaping, in the class-default class.

SUMMARY STEPS

1. **enable**
2. **configure terminal**
3. **policy-map** *policy-map*
4. **class** *class-default*
5. **shape** [**average** | **peak**] *mean-rate* [[*burst-size*] [*excess-burst-size*]]
6. **shape adaptive** *mean-rate-lower-bound*
7. **shape fr-voice-adapt** [**deactivation** *seconds*]
8. **Service-policy** *policy-map-name*
9. **end**

DETAILED STEPS

Command or Action	Purpose
Step 1 enable Example: <pre>Router> enable</pre>	Enables privileged EXEC mode. <ul style="list-style-type: none"> • Enter your password if prompted.
Step 2 configure terminal Example: <pre>Router# configure terminal</pre>	Enters global configuration mode.
Step 3 policy-map <i>policy-map</i> Example: <pre>Router(config)# policy-map SHAPE</pre>	Specifies the name of the policy map to be created or modified. <ul style="list-style-type: none"> • Use this command to define the shaping policy.
Step 4 class <i>class-default</i> Example: <pre>Router(config-pmap)# class class-default</pre>	Specifies the default class so that you can configure or modify its policy.
Step 5 shape [average peak] <i>mean-rate</i> [[<i>burst-size</i>] [<i>excess-burst-size</i>]] Example: <pre>Router(config-pmap-c)# shape average 60000</pre>	Shapes traffic to the indicated bit rate according to the algorithm specified.

Command or Action	Purpose
Step 6 <code>shape adaptive mean-rate-lower-bound</code> Example: <pre>Router(config-pmap-c)# shape adaptive 30000</pre>	(Optional) Configures a Frame Relay interface or a point-to-point subinterface to estimate the available bandwidth while traffic shaping is active.
Step 7 <code>shape fr-voice-adapt [deactivation seconds]</code> Example: <pre>Router(config-pmap-c)# shape fr-voice-adapt deactivation 10</pre>	Enables Frame Relay voice-adaptive traffic shaping.
Step 8 <code>Service-policy policy-map-name</code> Example: <pre>Router(config-pmap-c)#service-policy FR-VATS</pre>	Specifies the name of a policy map to be used as a matching criterion (for nesting traffic policies [hierarchical traffic policies] within one another). <ul style="list-style-type: none"> Use this command to attach the policy map for the priority queue and bandwidth queues (the child policies) to the shaping policy (the parent policy).
Step 9 <code>end</code>	(Optional) Exits to privileged EXEC mode.

Configuring a Map Class for Frame Relay Voice-Adaptive Traffic Shaping and Fragmentation

Perform the following task to configure a map class for Frame Relay voice-adaptive traffic shaping and fragmentation.

SUMMARY STEPS

1. `enable`
2. `configure terminal`
3. `map-class frame-relay map-class-name`
4. `frame-relay fragment fragment_size`
5. `service-policy output policy-map-name`
6. `end`

DETAILED STEPS

Command or Action	Purpose
<p>Step 1 <code>enable</code></p> <p>Example:</p> <pre>Router> enable</pre>	<p>Enables privileged EXEC mode.</p> <ul style="list-style-type: none"> Enter your password if prompted.
<p>Step 2 <code>configure terminal</code></p> <p>Example:</p> <pre>Router# configure terminal</pre>	<p>Enters global configuration mode.</p>
<p>Step 3 <code>map-class frame-relay map-class-name</code></p> <p>Example:</p> <pre>Router(config)# map-class frame-relay VOICE-CLASS</pre>	<p>Specifies the name of a Frame Relay map class that is to be created or modified.</p>
<p>Step 4 <code>frame-relay fragment fragment_size</code></p> <p>Example:</p> <pre>Router(config-map-class)# frame-relay fragment 80</pre>	<p>Enables Frame Relay fragmentation.</p> <p>Note For voice-adaptive fragmentation to work, fragmentation must be enabled here in a map class, or it can be configured directly on the interface.</p>
<p>Step 5 <code>service-policy output policy-map-name</code></p> <p>Example:</p> <pre>Router(config-map-class)# service-policy output SHAPE</pre>	<p>Attaches a policy map to an output interface, to be used as the service policy for that interface.</p> <ul style="list-style-type: none"> Use this command to attach the shaping policy to the map class.
<p>Step 6 <code>end</code></p> <p>Example:</p> <pre>Router(config-map-class)# end</pre>	<p>Exits to privileged EXEC mode.</p>

Enabling Frame Relay Voice-Adaptive Traffic Shaping and Fragmentation on the Interface

Perform the following task to enable Frame Relay voice-adaptive traffic shaping and fragmentation on the interface.

SUMMARY STEPS

1. **enable**
2. **configure terminal**
3. **interface** *type number*
4. **encapsulation frame-relay**
5. **frame-relay fragmentation voice-adaptive** [**deactivation** *seconds*]
6. **frame-relay fragment** *fragment-size end-to-end*
7. **frame-relay interface-dlci** *dlci* [**ietf** | **cisco**] [**voice-cir** *cir*]
8. **class** *name*
9. **end**

DETAILED STEPS

Command or Action	Purpose
Step 1 enable Example: <pre>Router> enable</pre>	Enables privileged EXEC mode. <ul style="list-style-type: none"> • Enter your password if prompted.
Step 2 configure terminal Example: <pre>Router# configure terminal</pre>	Enters global configuration mode.
Step 3 interface <i>type number</i> Example: <pre>Router(config)# interface serial0</pre>	Specifies the interface to be configured and enters interface configuration mode.
Step 4 encapsulation frame-relay Example: <pre>Router(config-if)# encapsulation frame-relay</pre>	Enables Frame Relay encapsulation.

Command or Action	Purpose
<p>Step 5 <code>frame-relay fragmentation voice-adaptive</code> <code>[deactivation seconds]</code></p> <p>Example:</p> <pre>Router(config-if)# frame-relay fragmentation voice-adaptive deactivation 50</pre>	<p>Enables Frame Relay voice-adaptive fragmentation.</p>
<p>Step 6 <code>frame-relay fragment</code> <i>fragment-size</i> <code>end-to-end</code></p> <p>Example:</p> <pre>Router(config-if)# frame-relay fragment 80 end-to-end</pre>	<p>Enables Frame Relay fragmentation on an interface.</p> <p>Note For voice-adaptive fragmentation to work, fragmentation must be enabled here on the interface, or it can be configured in a map class.</p> <ul style="list-style-type: none"> • When fragmentation is enabled on an interface, all PVCs on the main interface and its subinterfaces will have fragmentation enabled with the same configured fragment size. • To maintain low latency and low jitter for priority queue traffic, configure the fragment size to be greater than the largest high-priority frame that would be expected.
<p>Step 7 <code>frame-relay interface-dlci</code> <i>dlci</i> [<code>ietf</code> <code>cisco</code>] [<code>voice-cir</code> <i>cir</i>]</p> <p>Example:</p> <pre>Router(config-if)#</pre>	<p>Specifies a PVC to be configured.</p>
<p>Step 8 <code>class</code> <i>name</i></p> <p>Example:</p> <pre>Router(config-fr-dlci)#</pre>	<p>Associates a map class with a specified data-link connection identifier (DLCI).</p> <ul style="list-style-type: none"> • Use this command to assign the map class that was configured with Frame Relay voice-adaptive traffic shaping to the PVC.
<p>Step 9 <code>end</code></p> <p>Example:</p> <pre>Router(config-fr-dlci)# end</pre>	<p>Exits to privileged EXEC mode.</p>

Verifying Frame Relay Voice-Adaptive Traffic Shaping and Fragmentation

Perform this task to verify the configuration and operation of Frame Relay voice-adaptive traffic shaping and fragmentation.

SUMMARY STEPS

1. **enable**
2. **show policy-map** [*policy-map*]
3. **show policy-map interface** *interface-name* [**dlci** *dlci*] [**input** | **output**]
4. **show frame-relay pvc** [**interface** *interface*] [*dlci*] [**64-bit**]

DETAILED STEPS

	Command or Action	Purpose
Step 1	enable Example: Router> enable	Enables privileged EXEC mode. <ul style="list-style-type: none"> • Enter your password if prompted.
Step 2	show policy-map [<i>policy-map</i>] Example: Router# show policy-map	Displays the configuration of all classes for a specified service policy map or all classes for all existing policy maps.
Step 3	show policy-map interface <i>interface-name</i> [dlci <i>dlci</i>] [input output] Example: Router# show policy interface Serial3/1.1	Displays the packet statistics of all classes that are configured for all service policies either on the specified interface or subinterface or on a specific permanent virtual circuit (PVC) on the interface.
Step 4	show frame-relay pvc [interface <i>interface</i>] [<i>dlci</i>] [64-bit] Example: Router# show frame-relay pvc 202	Displays statistics about permanent virtual circuits (PVCs) for Frame Relay interface.

Configuration Examples for Frame Relay Voice-Adaptive Traffic Shaping and Fragmentation

- [Frame Relay Voice-Adaptive Traffic Shaping and Fragmentation Examples](#), page 170
- [Verifying Frame Relay Voice-Adaptive Traffic Shaping and Fragmentation Example](#), page 171

Frame Relay Voice-Adaptive Traffic Shaping and Fragmentation Examples

The following examples show the configuration of Frame Relay voice-adaptive traffic shaping and fragmentation. The first example shows end-to-end fragmentation configured in a map class that is associated with PVC 100. In the second example, end-to-end fragmentation is configured directly on the interface.

With both example configurations, priority-queue packets or H.323 call setup signaling packets destined for PVC 100 will result in the reduction of the sending rate from CIR to minCIR and the activation of FRF.12 end-to-end fragmentation. If signaling packets and priority-queue packets are not detected for 50 seconds, the sending rate will increase to CIR and fragmentation will be deactivated.

Frame Relay Voice-Adaptive Traffic Shaping and Fragmentation with End-to-End Fragmentation Configured in a Map Class

```
interface serial0
  encapsulation frame-relay
  frame-relay fragmentation voice-adaptive deactivation 50
  frame-relay interface-dlci 100
  class voice_adaptive_class
!
map-class frame-relay voice_adaptive_class
  frame-relay fragment 80
  service-policy output shape
class-map match-all voice
  match access-group 102
class-map match-all data
  match access-group 101
policy-map vats
  class voice
    priority 10
  class data
    bandwidth 10
policy-map shape
  class class-default
    shape average 60000
    shape adaptive 30000
    shape fr-voice-adapt deactivation 50
  service-policy vats
```

Frame Relay Voice-Adaptive Traffic Shaping and Fragmentation with End-to-End Fragmentation Configured on the Interface

```
interface serial0
  encapsulation frame-relay
  frame-relay fragmentation voice-adaptive deactivation 50
  frame-relay interface-dlci 100
  class voice_adaptive_class
    frame-relay fragment 80 end-to-end
!
map-class frame-relay voice_adaptive_class
  service-policy output shape

class-map match-all voice
  match access-group 102
class-map match-all data
  match access-group 101

policy-map vats
  class voice
    priority 10
  class data
    bandwidth 10
policy-map shape
```

```

class class-default
  shape average 60000
  shape adaptive 30000
  shape fr-voice-adapt deactivation 50
  service-policy vats

```

Verifying Frame Relay Voice-Adaptive Traffic Shaping and Fragmentation Example

Sample Output for the show policy-map Command

The following sample output for the **show-policy map** command indicates that Frame Relay voice-adaptive traffic shaping is configured in the class-default class in the policy map "MQC-SHAPE-LLQ1" and that the deactivation timer is set at 30 seconds.

```

Router# show policy-map
  Policy Map VSD1
    Class VOICE1
      Strict Priority
      Bandwidth 10 (kbps) Burst 250 (Bytes)
    Class SIGNALS1
      Bandwidth 8 (kbps) Max Threshold 64 (packets)
    Class DATA1
      Bandwidth 15 (kbps) Max Threshold 64 (packets)
  Policy Map MQC-SHAPE-LLQ1
    Class class-default
      Traffic Shaping
        Average Rate Traffic Shaping
          CIR 63000 (bps) Max. Buffers Limit 1000 (Packets)
          Adapt to 8000 (bps)
          Voice Adapt Deactivation Timer 30 Sec
      service-policy VSD1

```

Sample Output for the show policy interface Command

The following sample output shows that Frame Relay voice-adaptive traffic shaping is active and has 29 seconds left on the deactivation timer. This means that the current sending rate on DLCI 201 is minCIR, but if no voice packets are detected for 29 seconds, the sending rate will increase to CIR.

```

Router# show policy interface Serial3/1.1
Serial3/1.1:DLCI 201 -
  Service-policy output:MQC-SHAPE-LLQ1

  Class-map:class-default (match-any)
    1434 packets, 148751 bytes
    30 second offered rate 14000 bps, drop rate 0 bps
  Match:any
  Traffic Shaping
    Target/Average  Byte  Sustain  Excess  Interval  Increment
    Rate            Limit bits/int bits/int (ms) (bytes)
    63000/63000     1890  7560   7560   120       945

    Adapt Queue    Packets  Bytes  Packets  Bytes  Shaping
    Active Depth   Delayed  Delayed Active
    BECN  0         1434   162991  26     2704   yes
    Voice Adaptive Shaping active, time left 29 secs
  Service-policy :VSD1
  Class-map:VOICE1 (match-all)
    9 packets, 621 bytes
    30 second offered rate 0 bps, drop rate 0 bps
  Match:access-group 111
  Match:not access-group 112
  Queueing
    Strict Priority
    Output Queue:Conversation 24

```

```

Bandwidth 10 (kbps) Burst 250 (Bytes)
(pkts matched/bytes matched) 18/1242
(total drops/bytes drops) 0/0

Class-map: SIGNALS1 (match-all)
 0 packets, 0 bytes
 30 second offered rate 0 bps, drop rate 0 bps
 Match: access-group 112
 Queueing
   Output Queue: Conversation 25
     Bandwidth 8 (kbps) Max Threshold 64 (packets)
     (pkts matched/bytes matched) 0/0
 (depth/total drops/no-buffer drops) 0/0/0
Class-map: DATA1 (match-all)
 1424 packets, 148096 bytes
 30 second offered rate 14000 bps, drop rate 0 bps
 Match: access-group 113
 Queueing
   Output Queue: Conversation 26
     Bandwidth 15 (kbps) Max Threshold 64 (packets)
     (pkts matched/bytes matched) 1442/149968
 (depth/total drops/no-buffer drops) 0/0/0

Class-map: class-default (match-any)
 1 packets, 34 bytes
 30 second offered rate 0 bps, drop rate 0 bps
 Match: any

```

Sample Output for the show frame-relay pvc Command

The following sample output indicates that Frame Relay voice-adaptive fragmentation is active on DLCI 202 and there are 29 seconds left on the deactivation timer. If no packets are detected in the priority queue and no H.323 signaling packets are detected in the next 29 seconds, fragmentation will stop.

```

Router# show frame-relay pvc 202

PVC Statistics for interface Serial3/1 (Frame Relay DTE)

DLCI = 202, DLCI USAGE = LOCAL, PVC STATUS = STATIC, INTERFACE = Serial3/1.2

input pkts 0          output pkts 479          in bytes 0
out bytes 51226       dropped pkts 0           in pkts dropped 0
out pkts dropped 0   out bytes dropped 0
in FECN pkts 0       in BECN pkts 0          out FECN pkts 0
out BECN pkts 0     in DE pkts 0            out DE pkts 0
out bcast pkts 0    out bcast bytes 0
5 minute input rate 0 bits/sec, 0 packets/sec
5 minute output rate 5000 bits/sec, 5 packets/sec
pvc create time 00:23:36, last time pvc status changed 00:23:31
fragment type end-to-end fragment size 80 adaptive active, time left 29 secs

```

Additional References

Related Documents

Related Topic	Document Title
Traffic shaping, low latency queueing for Frame Relay, and Modular QoS CLI configuration tasks	<i>Cisco IOS Quality of Service Configuration Guide, Release 12.2</i>
Traffic shaping, low latency queueing for Frame Relay, and Modular QoS CLI commands	<i>Cisco IOS Quality of Service Command Reference, Release 12.2 T</i>

Related Topic	Document Title
Frame Relay fragmentation configuration tasks	<i>Cisco IOS Wide-Area Networking Configuration Guide</i> , Release 12.2
Frame Relay fragmentation commands	<i>Cisco IOS Wide-Area Networking Command Reference</i> , Release 12.2 T
Frame Relay interface queueing and fragmentation configuration tasks and commands	"Frame Relay Queueing and Fragmentation at the Interface," Cisco IOS Release 12.2(13)T feature module
Adaptive Frame Relay traffic shaping for interface congestion configuration tasks and commands	"Adaptive Frame Relay Traffic Shaping for Interface Congestion," Cisco IOS Release 12.2(4)T feature module

Standards

Standards	Title
No new or modified standards are supported by this feature. Support for existing standards has not been modified by this feature.	--

MIBs

MIBs	MIBs Link
No new or modified MIBs are supported by this feature. Support for existing MIBs has not been modified by this feature.	To obtain lists of supported MIBs by platform and Cisco IOS release, and to download MIB modules, go to the Cisco MIB website on Cisco.com at the following URL: http://www.cisco.com/public/sw-center/netmgmt/cmtk/mibs.shtml

RFCs

RFCs	Title
No new or modified RFCs are supported by this feature. Support for existing RFCs has not been modified by this feature.	--

Technical Assistance

Description	Link
Technical Assistance Center (TAC) home page, containing 30,000 pages of searchable technical content, including links to products, technologies, solutions, technical tips, and tools. Registered Cisco.com users can log in from this page to access even more content.	http://www.cisco.com/public/support/tac/home.shtml

Cisco and the Cisco Logo are trademarks of Cisco Systems, Inc. and/or its affiliates in the U.S. and other countries. A listing of Cisco's trademarks can be found at www.cisco.com/go/trademarks. Third party trademarks mentioned are the property of their respective owners. The use of the word partner does not imply a partnership relationship between Cisco and any other company. (1005R)

Any Internet Protocol (IP) addresses and phone numbers used in this document are not intended to be actual addresses and phone numbers. Any examples, command display output, network topology diagrams, and other figures included in the document are shown for illustrative purposes only. Any use of actual IP addresses or phone numbers in illustrative content is unintentional and coincidental.



Frame Relay IP RTP Priority

This feature module describes the Frame Relay IP RTP Priority feature.

- [Finding Feature Information, page 175](#)
- [Feature Overview, page 175](#)
- [Supported Platforms, page 176](#)
- [Supported Standards and MIBs and RFCs, page 176](#)
- [Prerequisites, page 177](#)
- [Configuration Tasks, page 177](#)
- [Monitoring and Maintaining Frame Relay IP RTP Priority, page 178](#)
- [Configuration Examples, page 178](#)

Finding Feature Information

Your software release may not support all the features documented in this module. For the latest feature information and caveats, see the release notes for your platform and software release. To find information about the features documented in this module, and to see a list of the releases in which each feature is supported, see the Feature Information Table at the end of this document.

Use Cisco Feature Navigator to find information about platform support and Cisco software image support. To access Cisco Feature Navigator, go to www.cisco.com/go/cfn. An account on Cisco.com is not required.

Feature Overview

The Frame Relay IP RTP Priority feature provides a strict priority queueing scheme on a Frame Relay permanent virtual circuit (PVC) for delay-sensitive data such as voice. Voice traffic can be identified by its Real-Time Transport Protocol (RTP) port numbers and classified into a priority queue configured by the **frame-relay ip rtp priority** command. The result of using this feature is that voice is serviced as strict priority in preference to other nonvoice traffic.

This feature extends the functionality offered by the **ip rtp priority** command by supporting Frame Relay PVCs. This feature allows you to specify a range of User Datagram Protocol (UDP) ports whose voice traffic is guaranteed strict priority service over any other queues or classes using the same output interface. Strict priority means that if packets exist in the priority queue, they are dequeued and sent first--that is, before packets in other queues are dequeued.

- [Benefits, page 176](#)
- [Related Features and Technologies, page 176](#)
- [Related Documents, page 176](#)

Benefits

The strict priority queueing scheme allows delay-sensitive data such as voice to be dequeued and sent first--that is, before packets in other queues are dequeued. Delay-sensitive data is given preferential treatment over other traffic. This process is performed on a per-PVC basis, rather than at the interface level.

Related Features and Technologies

The Frame Relay IP RTP Priority feature is related to the following features:

- IP RTP Priority
- Class-based weighted fair queueing (CBWFQ)
- Priority queueing
- Weighted fair queueing (WFQ)

Related Documents

- *Quality of Service Solutions Configuration Guide* , Cisco IOS Release 12.0
- *Quality of Service Solutions Command Reference* , Cisco IOS Release 12.0
- *Class-Based Weighted Fair Queueing*
- *IP RTP Priority*

Supported Platforms

- Cisco 1003
- Cisco 1004
- Cisco 1005
- Cisco 1600 series
- Cisco 2500 series
- Cisco 2600 series
- Cisco 3600 series
- Cisco 3800 series
- Cisco 4000 series (Cisco 4000, 4000-M, 4500, 4500-M, 4700, 4700-M)
- Cisco 5200 series
- Cisco 7000 series
- Cisco 7200 series
- Cisco 7500 series

This feature runs on the platforms listed. However, it is most useful on voice supported platforms, such as the Cisco 2600 series, Cisco 3600 series, Cisco 7200 series, and Cisco 7500 Route Switch Processor (RSP) series.

Supported Standards and MIBs and RFCs

Standards

None

MIBs

No new or modified MIBs are supported by this feature.

RFCs

None

Prerequisites

Frame Relay traffic shaping (FRTS) and Frame Relay Fragmentation (FRF.12) must be configured before the Frame Relay IP RTP Priority feature is used.

Configuration Tasks

- [Configuring Frame Relay IP RTP Priority, page 177](#)
- [Verifying Frame Relay IP RTP Priority, page 177](#)

Configuring Frame Relay IP RTP Priority

To reserve a strict priority queue on a Frame Relay PVC for a set of RTP packet flows belonging to a range of UDP destination ports, use the following command in map-class configuration mode.

**Note**

Because the **frame-relay ip rtp priority** command gives absolute priority over other traffic, it should be used with care. In the event of congestion, if the traffic exceeds the configured bandwidth, then all the excess traffic is dropped.

Command	Purpose
Router(config-map-class)# frame-relay ip rtp priority <i>starting-rtp-port-number port-number-range bandwidth</i>	Reserves a strict priority queue for a set of RTP packet flows belonging to a range of UDP destination ports.

Verifying Frame Relay IP RTP Priority

To verify the Frame Relay IP RTP Priority feature, use one of the following commands in EXEC mode:

Command	Purpose
Router# show frame relay pvc	Displays statistics about PVCs for Frame Relay interfaces.

Command	Purpose
Router# show queue <i>interface-type interface-number</i>	Displays fair queueing configuration and statistics for a particular interface.
Router# show traffic-shape queue	Displays information about the elements queued at a particular time at the VC data link connection identifier (DLCI) level.

Monitoring and Maintaining Frame Relay IP RTP Priority

To tune your RTP bandwidth or decrease RTP traffic if the priority queue is experiencing drops, use the following command in EXEC mode:

Command	Purpose
Router# debug priority	Displays priority queueing output if packets are dropped from the priority queue.

Configuration Examples

- [Frame Relay IP RTP Priority Configuration Example, page 178](#)

Frame Relay IP RTP Priority Configuration Example

The following example first configures the Frame Relay map class called voip and then applies the map class to PVC 100 to provide strict priority service to matching RTP packets:

```
map-class frame-relay voip
 frame-relay cir 256000
 frame-relay bc 2560
 frame-relay be 600
 frame-relay mincir 256000
 no frame-relay adaptive-shaping
 frame-relay fair-queue
 frame-relay fragment 250
 frame-relay ip rtp priority 16384 16380 210
 interface Serial5/0
 ip address 10.10.10.10 255.0.0.0
 no ip directed-broadcast
 encapsulation frame-relay
 no ip mroute-cache
 load-interval 30
 clockrate 1007616
 frame-relay traffic-shaping
 frame-relay interface-dlci 100
 class voip
 frame-relay ip rtp header-compression
 frame-relay intf-type dce
```

In this example, RTP packets on PVC 100 with UDP ports in the range 16384 to 32764 will be matched and given strict priority service.

Cisco and the Cisco Logo are trademarks of Cisco Systems, Inc. and/or its affiliates in the U.S. and other countries. A listing of Cisco's trademarks can be found at www.cisco.com/go/trademarks. Third party trademarks mentioned are the property of their respective owners. The use of the word partner does not imply a partnership relationship between Cisco and any other company. (1005R)

Any Internet Protocol (IP) addresses and phone numbers used in this document are not intended to be actual addresses and phone numbers. Any examples, command display output, network topology diagrams, and other figures included in the document are shown for illustrative purposes only. Any use of actual IP addresses or phone numbers in illustrative content is unintentional and coincidental.



PPP over Frame Relay

The PPP over Frame Relay feature allows a router to establish end-to-end Point-to-Point Protocol (PPP) sessions over Frame Relay.

- [Finding Feature Information, page 181](#)
- [Prerequisites for PPP over Frame Relay, page 181](#)
- [Restrictions for PPP over Frame Relay, page 181](#)
- [Information About PPP over Frame Relay, page 182](#)
- [How to Configure PPP over Frame Relay, page 183](#)
- [Configuration Examples for PPP over Frame Relay, page 184](#)
- [Additional References, page 185](#)
- [Feature Information for PPP over Frame Relay, page 186](#)
- [Glossary, page 187](#)

Finding Feature Information

Your software release may not support all the features documented in this module. For the latest feature information and caveats, see the release notes for your platform and software release. To find information about the features documented in this module, and to see a list of the releases in which each feature is supported, see the Feature Information Table at the end of this document.

Use Cisco Feature Navigator to find information about platform support and Cisco software image support. To access Cisco Feature Navigator, go to www.cisco.com/go/cfn. An account on Cisco.com is not required.

Prerequisites for PPP over Frame Relay

Before you can configure PPP over Frame Relay, Frame Relay must be enabled on the router using the **encapsulation frame-relay** command.

Restrictions for PPP over Frame Relay

- Only Frame Relay permanent virtual circuits (PVCs) are supported.
- Only the Internet Protocol (IP) is supported.

Information About PPP over Frame Relay

- [Overview of PPP over Frame Relay, page 182](#)
- [Benefits, page 183](#)

Overview of PPP over Frame Relay

The PPP over Frame Relay feature allows a router to establish end-to-end Point-to-Point Protocol (PPP) sessions over Frame Relay. IP datagrams are transported over the PPP link using RFC 1973 compliant Frame Relay framing. This feature is useful for remote users running PPP to access their Frame Relay corporate networks as shown in [GUID-1B2A1381-F6A3-4EA1-B072-C44C1257E7762](#).

[GUID-511DA5F7-7AD2-4A93-AD36-158FA6DFB03D2](#) shows a connectivity scenario using the Cisco 90i D4 channel card, which is capable of supporting Integrated Services Digital Network (ISDN) Digital Service Loop (DSL), PPP, or Frame Relay, which connects to an Internet Service Provider (ISP) or corporate network.

Figure 17 *PPP over Frame Relay Scenario*

MISSING ILLO, EMBEDDED, NOT REFERENCED; writer must fix

Figure 18 *PPP over Frame Relay Frame Format*

MISSING ILLO, EMBEDDED, NOT REFERENCED; writer must fix

PPP over Frame Relay is compliant with the functionality and encapsulation specifications as outlined in RFC 1973. The frame format is shown in [GUID-D9B62477-7446-4A4E-ACEB-F5190D9629702](#).

A PPP connection is established over the Frame Relay PVC. The PPP session does not occur unless the associated Frame Relay PVC is in an "active" state. The Frame Relay VC can coexist with other circuits using different Frame Relay encapsulation methods, such as RFC 1490 and Cisco proprietary, over the same Frame Relay link. There can be multiple PPP-in-Frame-Relay circuits existing on one Frame Relay link.

One PPP connection resides on one virtual access interface, which is internally created from a virtual template interface. A virtual access interface is cloned from a virtual template interface. The virtual access interfaces is coexistent with the creation of the Frame Relay circuit when the corresponding DLCI is configured. One virtual template interface, containing all the necessary PPP and network protocol information, is shared by multiple virtual access interfaces. Hardware compression and fancy queuing algorithms, such as weighted fair queuing, custom queuing, and priority queuing, are not applied to virtual access interfaces. Once a Frame Relay circuit is established using PPP over Frame Relay, all incoming and outgoing packets on this circuit are under RFC 1973 PPP-in-Frame-Relay encapsulation compliance until this DLCI is removed from the configuration.

Figure 19 *PPP over Frame Relay Frame Format*

MISSING ILLO, EMBEDDED, NOT REFERENCED; writer must fix

The breakdown of the Frame Relay frame format components is listed in the table below.

Table 6 PPP Frame Relay Format Descriptions

Field	Description
Flag	A single byte that indicates the beginning or end of a frame.
Address	A two-byte field that indicates the logical connection that maps to the physical channel; the DLCI.
Control	A single byte that calls for transmission of user data. PPP over Frame Relay uses a value of 0X03, which indicates that the frame is an unnumbered information (UI) frame.
NLPID	Network layer protocol ID, which is a single byte that uniquely identifies a PPP packet to Frame Relay.
PPP protocol	Identifies the PPP packet type.

Benefits

- Allows end-to-end PPP sessions over Frame Relay.
- Supports the 90i IDSL Channel Unit that supports both Frame Relay and PPP on an ISDN DSL.

How to Configure PPP over Frame Relay

- [Enabling PPP over Frame Relay, page 183](#)

Enabling PPP over Frame Relay

Perform the following task to configure the physical interface that carries the PPP session and links to the appropriate virtual template interface.

After you configure the Cisco router or access server for Frame Relay encapsulation, you must configure the physical interface with the PVC and apply a virtual template with PPP encapsulation to the DLCI that it applies to.

SUMMARY STEPS

1. **enable**
2. **configure terminal**
3. **interface type number . subinterface-number { multipoint | point-to-point }**
4. **frame-relay interface-dlci dlci [ppp virtual-template-name-string]**
5. **end**

DETAILED STEPS

Command or Action	Purpose
<p>Step 1 <code>enable</code></p> <p>Example:</p> <pre>Router> enable</pre>	<p>Enables privileged EXEC mode.</p> <ul style="list-style-type: none"> Enter your password if prompted.
<p>Step 2 <code>configure terminal</code></p> <p>Example:</p> <pre>Router# configure terminal</pre>	<p>Enters global configuration mode.</p>
<p>Step 3 <code>interface type number . subinterface-number {multipoint point-to-point}</code></p> <p>Example:</p> <pre>Router(config)# interface serial 2.1 point-to-point</pre>	<p>Specifies the interface and enters interface configuration mode.</p>
<p>Step 4 <code>frame-relay interface-dlci dlci [ppp virtual-template-name-string]</code></p> <p>Example:</p> <pre>Router(config-if)# frame-relay interface-dlci</pre>	<p>Defines the PVC and maps it to the virtual template.</p>
<p>Step 5 <code>end</code></p> <p>Example:</p> <pre>Router(config-if)# exit</pre>	<p>Exits the current configuration mode and returns to privileged EXEC mode.</p>

Configuration Examples for PPP over Frame Relay

- [Example PPP over Frame Relay DTE, page 184](#)
- [Example PPP over Frame Relay DCE, page 185](#)

Example PPP over Frame Relay DTE

The following example configures a router as a data terminating equipment (DTE) device for PPP over Frame Relay. Subinterface 2.1 contains the necessary DLCI and virtual template information. The virtual

template interface (interface virtual-template 1) contains the PPP information that is applied to the PPP session associated with DLCI 32 on serial subinterface 2.1.

```
interface serial 2
  no ip address
  encapsulation frame-relay
  frame-relay lmi-type ansi
!
interface serial 2.1 point-to-point
  frame-relay interface-dlci 32 ppp virtual-templ1
!
interface Virtual-Templ1
  ip unnumbered ethernet 0
  ppp authentication chap pap
```

**Note**

By default, the encapsulation type for a virtual template interface is PPP encapsulation; therefore, the **encapsulation ppp** command will not show up when viewing the running configuration on the router.

Example PPP over Frame Relay DCE

The following example configures a router to act as a data communications equipment (DCE) device. Typically, a router is configured as a DCE if connecting directly to another router or if connected to a 90i D4 channel unit, which is connected to a telco channel bank. The three commands required for this type of configuration are **frame-relay switching**, **frame-relay intf-type dce**, and **frame-relay route** commands.

```
frame-relay switching
!
interface Serial2/0:0
  no ip address
  encapsulation frame-relay IETF
  frame-relay lmi-type ansi
  frame-relay intf-type dce
  frame-relay route 31 interface Serial1/2 100
  frame-relay interface-dlci 32 ppp Virtual-Templ1
!
interface Serial2/0:0.2 point-to-point
  no ip address
  frame-relay interface-dlci 40 ppp Virtual-Template2
!
interface Virtual-Templ1
  ip unnumbered Ethernet0/0
  peer default ip address pool default
  ppp authentication chap pap
!
interface Virtual-Template2
  ip address 209.165.200.225 255.255.255.224
  ppp authentication chap pap
```

**Note**

By default, the encapsulation type for a virtual template interface is PPP encapsulation; therefore, the **encapsulation ppp** command will not show up when viewing the running configuration on the router.

Additional References

Related Documents

Related Topic	Document Title
Cisco IOS commands	Cisco IOS Master Commands List, All Releases
WAN commands	<i>Cisco IOS Wide-Area Networking Command Reference</i>
Configuring Frame Relay	Configuring Frame Relay

Standards

Standard	Title
None	--

MIBs

MIB	MIBs Link
None	To locate and download MIBs for selected platforms, Cisco software releases, and feature sets, use Cisco MIB Locator found at the following URL: http://www.cisco.com/go/mibs

RFCs

RFC	Title
RFC 1973	<i>PPP in Frame Relay</i>

Technical Assistance

Description	Link
The Cisco Support and Documentation website provides online resources to download documentation, software, and tools. Use these resources to install and configure the software and to troubleshoot and resolve technical issues with Cisco products and technologies. Access to most tools on the Cisco Support and Documentation website requires a Cisco.com user ID and password.	http://www.cisco.com/cisco/web/support/index.html

Feature Information for PPP over Frame Relay

The following table provides release information about the feature or features described in this module. This table lists only the software release that introduced support for a given feature in a given software

release train. Unless noted otherwise, subsequent releases of that software release train also support that feature.

Use Cisco Feature Navigator to find information about platform support and Cisco software image support. To access Cisco Feature Navigator, go to www.cisco.com/go/cfn. An account on Cisco.com is not required.

Table 7 Feature Information for PPP over Frame Relay

Feature Name	Releases	Feature Information
PPP over Frame Relay	11.3(4)T 15.0(1)S	<p>The PPP over Frame Relay feature allows a router to establish end-to-end PPP sessions over Frame Relay.</p> <p>The following commands were introduced or modified: debug frame-relay ppp, frame-relay interface-dlci, show frame-relay pvc.</p>

Glossary

data-link connection identifier (DLCI) --A value that specifies a PVC or SVC in a Frame Relay network. In the basic Frame Relay specification, DLCIs are locally significant (connected devices might use different values to specify the same connection). In the LMI extended specification, DLCIs are globally significant (DLCIs specify individual end devices).

Integrated Services Digital Network (ISDN) --Communication protocols offered by telephone companies that permit telephone networks to carry data, voice, and other source traffic.

Link Control Protocol (LCP) --A protocol that establishes, configures, and tests data link connections used by PPP.

permanent virtual circuit (PVC) --Virtual circuit that is permanently established. PVCs save bandwidth associated with circuit establishment and teardown in situations where certain virtual circuits must exist all the time.

Point-to-Point Protocol (PPP) --A protocol that encapsulates network layer protocol information over point-to-point links. The RFC for PPP is RFC 1661.

virtual circuit (VC) -- A logical circuit created to ensure reliable communication between two network devices. A virtual circuit can be either permanent (a PVC) or switched (an SVC). Virtual circuits are used in Frame Relay and X.25.

Cisco and the Cisco Logo are trademarks of Cisco Systems, Inc. and/or its affiliates in the U.S. and other countries. A listing of Cisco's trademarks can be found at www.cisco.com/go/trademarks. Third party trademarks mentioned are the property of their respective owners. The use of the word partner does not imply a partnership relationship between Cisco and any other company. (1005R)

Any Internet Protocol (IP) addresses and phone numbers used in this document are not intended to be actual addresses and phone numbers. Any examples, command display output, network topology diagrams,

and other figures included in the document are shown for illustrative purposes only. Any use of actual IP addresses or phone numbers in illustrative content is unintentional and coincidental.



MQC-Based Frame Relay Traffic Shaping

The MQC-Based Frame Relay Traffic Shaping feature provides users with the ability to configure Frame Relay traffic shaping (FRTS) using modular quality of service (QoS) command-line interface (CLI) commands. Modular QoS CLI is known as MQC.

This feature is available for the Cisco routers specified in the [MQC-Based Frame Relay Traffic Shaping, page 189](#) section.

Supported Platforms

Cisco 1700 series, Cisco 2500 series, Cisco 2600 series, Cisco 3620 router, Cisco 3631 router, Cisco 3640 router, Cisco 3660 router, Cisco 3725 router, Cisco 3745 router, Cisco 7200 series, Cisco 7400 series, Cisco 7500 series and above

- [Finding Feature Information, page 189](#)
- [Prerequisites for MQC-Based Frame Relay Traffic Shaping, page 189](#)
- [Restrictions for MQC-Based Frame Relay Traffic Shaping, page 190](#)
- [Information About MQC-Based Frame Relay Traffic Shaping, page 190](#)
- [How to Configure MQC-Based Frame Relay Traffic Shaping, page 192](#)
- [Configuration Examples for MQC-Based Frame Relay Traffic Shaping, page 204](#)
- [Additional References, page 205](#)
- [Feature Information for MQC-Based Frame Relay Traffic Shaping, page 206](#)

Finding Feature Information

Your software release may not support all the features documented in this module. For the latest feature information and caveats, see the release notes for your platform and software release. To find information about the features documented in this module, and to see a list of the releases in which each feature is supported, see the Feature Information Table at the end of this document.

Use Cisco Feature Navigator to find information about platform support and Cisco software image support. To access Cisco Feature Navigator, go to www.cisco.com/go/cfn. An account on Cisco.com is not required.

Prerequisites for MQC-Based Frame Relay Traffic Shaping

Every permanent virtual circuit (PVC) to which FRTS using MQC is applied must have Frame Relay encapsulation enabled on the associated interface with the **encapsulation frame-relay** command.

**Note**

For FRTS using MQC for the routers specified in the [Prerequisites for MQC-Based Frame Relay Traffic Shaping, page 189](#) section, distributed Cisco Express Forwarding is not required. For FRTS using MQC for routers in the Cisco 7500 and above product range, distributed Cisco Express Forwarding is required.

Restrictions for MQC-Based Frame Relay Traffic Shaping

You must create a default class for the service policy as specified with the **class class-default** command to configure FRTS using MQC on a Frame Relay PVC. The default class will have all the FRTS parameters applied to it. Refer to the [Creating a Policy Map and Entering CBWFQ Parameters for the Class Map, page 194](#) section for more information on creating a default class structure for a service policy.

If FRTS and fragmentation are applied to a PVC using MQC, the interface queue will change to dual first-in, first-out (FIFO) queueing. The two queues will consist of a high-priority queue to carry VoIP and certain control packets, and a low-priority queue to carry all other packets.

**Note**

In configurations created by using traditional FRTS commands, the minimum acceptable outgoing committed information rate (minCIR) will be used as the total available bandwidth for a policy map that has class-based weighted fair queueing (CBWFQ) attached to the map class for the PVC. If the MQC-Based Frame Relay Traffic Shaping feature is used to configure FRTS, the shaping rate that was configured in the parent policy map using MQC will be used as the total available bandwidth for the child policy map, if CBWFQ is configured. If both the **shape average** and **shape adaptive** commands are used for traffic shaping, the available bandwidth will be based on the parameters specified by the **shape adaptive** command

Information About MQC-Based Frame Relay Traffic Shaping

- [MQC Overview, page 190](#)
- [FRTS Overview, page 191](#)
- [Feature Design of MQC-Based Frame Relay Traffic Shaping, page 191](#)
- [Benefits of MQC-Based Frame Relay Traffic Shaping, page 192](#)

MQC Overview

MQC is used to configure FRTS. MQC is a framework that provides a clear separation between a classification policy and the specification of other parameters that act on the results of that applied classification policy.

Before this feature was introduced in Cisco IOS Release 12.2(13)T, FRTS for the Cisco routers specified in the [MQC Overview, page 190](#) section could be configured only by using traditional FRTS commands (refer to the [How to Configure MQC-Based Frame Relay Traffic Shaping, page 192](#) section for more information). With the addition of the MQC-Based Frame Relay Traffic Shaping feature, FRTS can be configured on routers throughout the Cisco router product line by using MQC.

Broadly, MQC is configured and implemented as follows:

- Define a traffic class with the **class-map** command.
- Create a service policy by associating the traffic class with one or more QoS features (using the **policy-map** command).
- Attach the service policy to the interface with the **service-policy** command.

For more detailed information on MQC, refer to the document Modular Quality of Service Command-Line Interface. MQC commands used for FRTS are further explained in the [How to Configure MQC-Based Frame Relay Traffic Shaping](#), page 192 section of this document.

FRTS Overview

FRTS allows you to control the traffic going out through a PVC in order to match its flow to the speed of the remote target interface and to ensure that the traffic conforms to the parameters that have been set for it. Traffic that matches a particular profile can be shaped to meet downstream requirements, thereby eliminating the bottlenecks that occur in topologies that have data-rate mismatches.

The primary reasons you would use FRTS are the following:

- To allow high-priority packets to take precedence over other packets as they are encapsulated and forwarded over the Frame Relay network. FRTS is useful for applications such as VoIP and streaming video, which require a low latency to be effective.
- To control access to available bandwidth.
- To ensure that traffic conforms to the parameters established for it.
- To regulate the flow of traffic in order to avoid congestion that can occur when the sent traffic exceeds the access speed of its remote target interface.
- To eliminate bottlenecks in Frame Relay networks that have high-speed connections at the central site and low-speed connections at branch sites by configuring rate enforcement to limit the rate at which data is sent on the virtual circuit (VC) at the central site. Rate enforcement is a peak rate configured to limit outbound traffic.

Feature Design of MQC-Based Frame Relay Traffic Shaping

The MQC-Based Frame Relay Traffic Shaping feature allows the Cisco routers specified in the [Feature Design of MQC-Based Frame Relay Traffic Shaping](#), page 191 section to have FRTS configured using MQC instead of traditional FRTS commands.

Before this feature was introduced in Cisco IOS Release 12.2(13)T, FRTS for the Cisco routers specified in the [Feature Design of MQC-Based Frame Relay Traffic Shaping](#), page 191 section could be configured only by using traditional FRTS commands (for example, the **frame-relay traffic-shaping** command). For traditional FRTS, all traffic shaping and fragmentation values are entered under the map class. Traffic shaping is defined by entering the **map-class frame-relay** command, then entering the traffic shaping and, optionally, fragmentation values.

For routers in the Cisco 7500 and above product range, Distributed Traffic Shaping (DTS) is used for traffic shaping. With DTS, the traffic-shaping values are configured by entering the **policy-map** command, then entering the traffic-shaping values. However, fragmentation values are still entered under the map class—the **map-class frame-relay** command is still used before any fragmentation values are entered.

The traffic-shaping commands supported by the MQC-Based Frame Relay Traffic Shaping feature are listed in the [Supported MQC Frame Relay Traffic Shaping Commands](#), page 192 section.

CBWFQ can also be configured under the policy map by entering the **policy-map** command and then entering the traffic-shaping CBWFQ values.

**Note**

Configuring traffic shaping using MQC and configuring traffic shaping using traditional FRTS commands are mutually exclusive. Traffic shaping cannot be configured on the same interface using both methods.

- [Supported MQC Frame Relay Traffic Shaping Commands, page 192](#)

Supported MQC Frame Relay Traffic Shaping Commands

The following MQC traffic-shaping commands are supported by the MQC-Based Frame Relay Traffic Shaping feature:

- **shape {average | peak}**
- **shape adaptive**
- **shape fecn-adapt**
- **shape max-buffers**

The **frame-relay ip rtp priority** command is not supported.

**Note**

Before this feature was introduced in Cisco IOS Release 12.2(13)T, FRTS for the Cisco routers specified in the [Supported MQC Frame Relay Traffic Shaping Commands, page 192](#) section could be configured only by using traditional FRTS commands (refer to the [How to Configure MQC-Based Frame Relay Traffic Shaping, page 192](#) section for more information).

Benefits of MQC-Based Frame Relay Traffic Shaping

MQC allows users to specify a traffic class independently of QoS parameters.

The MQC-Based Frame Relay Traffic Shaping feature allows users to apply FRTS parameters using MQC across the entire Cisco router product line.

This feature ensures that FRTS is defined in the same manner for routers across the Cisco router product line, rather than only for routers in the Cisco 7500 and above product range.

Before this feature was introduced in Cisco IOS Release 12.2(13)T, FRTS for the Cisco routers specified in the [Benefits of MQC-Based Frame Relay Traffic Shaping, page 192](#) section could be defined only by using traditional FRTS commands. Using different methods to define FRTS for different routers can introduce inconsistency and complexity when FRTS is being implemented on different router platforms.

How to Configure MQC-Based Frame Relay Traffic Shaping

- [Creating a Class Map and Specifying Match Criteria for CBWFQ, page 193](#)
- [Creating a Policy Map and Entering CBWFQ Parameters for the Class Map, page 194](#)
- [Creating a Shaping Policy Map and Entering FRTS Values for the Default Class Map, page 195](#)
- [Attaching the Class-Based Weighted Fair Queueing Policy Map to the Shaping Policy Map, page 197](#)
- [Specifying a Map Class and Attaching a Service Policy for the PVC, page 198](#)
- [Configuring an Interface or Subinterface for Frame Relay and Associating a Map Class with a PVC, page 199](#)

- [Defining Fragmentation Parameters for the PVC, page 201](#)
- [Adding the Policy Map to the Map Class, page 202](#)

Creating a Class Map and Specifying Match Criteria for CBWFQ

To create a class map and specify match criteria for CBWFQ, use the following commands.

SUMMARY STEPS

1. **enable**
2. **configure terminal**
3. **class-map** *class-map-name*
4. **match** *match-criteria*
5. **end**

DETAILED STEPS

Command or Action	Purpose
Step 1 enable Example: Router> enable	Enables privileged EXEC mode. <ul style="list-style-type: none"> • Enter your password if prompted.
Step 2 configure terminal Example: Router# configure terminal	Enters global configuration mode.
Step 3 class-map <i>class-map-name</i> Example: Router(config)# class-map voice	Creates a class map to be used for matching packets to a specified class and enters class-map configuration mode. <ul style="list-style-type: none"> • The example command creates a class map named "voice".
Step 4 match <i>match-criteria</i> Example: Router(config-cmap)# match ip dscp ef	Identifies packets that will belong to the class map. <ul style="list-style-type: none"> • The example command identifies an IP differentiated service code point (DSCP) value of EF (101110) as a match criterion for the class map named "voice".
Step 5 end Example: Router(config-cmap)# end	(Optional) Exits class-map configuration mode and returns to privileged EXEC mode.

Creating a Policy Map and Entering CBWFQ Parameters for the Class Map

To create a policy map and enter CBWFQ parameters for the class map, use the following commands.

SUMMARY STEPS

1. **enable**
2. **configure terminal**
3. **policy-map** *policy-map-name*
4. **class** *name*
5. **priority** [*bandwidth-kbps* | **percent** *percentage*] [*burst*]
6. **end**

DETAILED STEPS

	Command or Action	Purpose
Step 1	enable Example: Router> enable	Enables privileged EXEC mode. <ul style="list-style-type: none"> • Enter your password if prompted.
Step 2	configure terminal Example: Router# configure terminal	Enters global configuration mode.
Step 3	policy-map <i>policy-map-name</i> Example: Router(config)# policy-map llq	Creates a policy map that can be attached to one or more interfaces to specify a service policy and enters policy-map configuration mode. <ul style="list-style-type: none"> • The example command creates a policy map named "llq". This policy map will be used for low latency queueing (LLQ).
Step 4	class <i>name</i> Example: Router(config-pmap)# class voice	Specifies the name of the class whose policy you want to create and enters policy-map class configuration mode. <ul style="list-style-type: none"> • The example command creates a traffic class named "voice".
Step 5	priority [<i>bandwidth-kbps</i> percent <i>percentage</i>] [<i>burst</i>] Example: Router(config-pmap-c)# priority 32	(Optional) Gives priority to a class of traffic belonging to a policy map. <ul style="list-style-type: none"> • The example command provides a guaranteed allowed bandwidth of 32 kbps and a guaranteed low latency for up to 32 kbps to the traffic class "voice" that was created in Creating a Policy Map and Entering CBWFQ Parameters for the Class Map, page 194.

Command or Action	Purpose
Step 6 <code>end</code> Example: <code>Router(config-pmap-c)# end</code>	(Optional) Exits policy-map class configuration mode and returns to privileged EXEC mode.

Creating a Shaping Policy Map and Entering FRTS Values for the Default Class Map

To create a shaping policy map and enter FRTS values for the default class map, use the following commands.

SUMMARY STEPS

1. `enable`
2. `configure terminal`
3. `policy-map` *policy-map-name*
4. `class class-default`
5. `shape {average | peak} {mean-rate [burst-size [excess-burst-size]] | percent percentage [burst-size ms [excess-burst [ms]]]}`
6. `shape adaptive` *mean-rate-lower-bound*
7. `shape fecn-adapt`
8. `end`

DETAILED STEPS

Command or Action	Purpose
Step 1 <code>enable</code> Example: <code>Router> enable</code>	Enables privileged EXEC mode. <ul style="list-style-type: none"> • Enter your password if prompted.
Step 2 <code>configure terminal</code> Example: <code>Router# configure terminal</code>	Enters global configuration mode.

Command or Action	Purpose
<p>Step 3 <code>policy-map <i>policy-map-name</i></code></p> <p>Example:</p> <pre>Router(config)# policy-map shape-policy-map</pre>	<p>Creates a policy map that can be attached to one or more interfaces to specify a service policy and enters policy-map configuration mode.</p> <ul style="list-style-type: none"> The example command creates a policy map named shape-policy-map.
<p>Step 4 <code>class class-default</code></p> <p>Example:</p> <pre>Router(config-pmap)# class class-default</pre>	<p>Specifies the default class (commonly known as the class-default class) before you configure its policy and enters policy-map class configuration mode.</p> <ul style="list-style-type: none"> The class-default class is the class to which traffic is directed if that traffic does not satisfy the match criteria of other classes whose policy is defined in the policy map. Only one class is defined with this command (the class-default class); therefore, it will match all traffic.
<p>Step 5 <code>shape {average peak} {mean-rate [burst-size [excess-burst-size]] percent percentage [burst-size ms [excess-burst ms]]}</code></p> <p>Example:</p> <pre>Router(config-pmap-c)# shape average 64000</pre>	<p>Shapes traffic to the indicated bit rate according to the algorithm specified.</p> <ul style="list-style-type: none"> The example command configures a shape entity with a CIR of 64,000 bytes per second (bps). Any FRTS commands supported by this feature can be used for traffic shaping. Refer to the Restrictions for MQC-Based Frame Relay Traffic Shaping, page 190 section for a list of supported FRTS commands.
<p>Step 6 <code>shape adaptive mean-rate-lower-bound</code></p> <p>Example:</p> <pre>Router(config-pmap-c)# shape adaptive 32000</pre>	<p>(Optional) Configures a Frame Relay PVC to estimate the available bandwidth by backward explicit congestion notification (BECN) integration while traffic shaping is enabled.</p> <ul style="list-style-type: none"> The example command sets the lower bound CIR to 32,000 bps when BECNs are received.
<p>Step 7 <code>shape fecn-adapt</code></p> <p>Example:</p> <pre>Router(config-pmap-c)# shape fecn-adapt</pre>	<p>(Optional) Configures a Frame Relay interface to reflect received forward explicit congestion notification (FECN) bits as BECN bits in Q.922 "Test Response" messages.</p> <ul style="list-style-type: none"> The example command adapts the Frame Relay message with FECN to BECN.
<p>Step 8 <code>end</code></p> <p>Example:</p> <pre>Router(config-pmap-c)# end</pre>	<p>(Optional) Exits policy-map class configuration mode and returns to privileged EXEC mode.</p>

Attaching the Class-Based Weighted Fair Queueing Policy Map to the Shaping Policy Map

To attach the CBWFQ policy map to the shaping policy map, use the following commands.

SUMMARY STEPS

1. **enable**
2. **configure terminal**
3. **policy-map** *policy-map-name*
4. **class class-default**
5. **service-policy** *policy-map-name*
6. **end**

DETAILED STEPS

Command or Action	Purpose
<p>Step 1 enable</p> <p>Example:</p> <pre>Router> enable</pre>	<p>Enables privileged EXEC mode.</p> <ul style="list-style-type: none"> • Enter your password if prompted.
<p>Step 2 configure terminal</p> <p>Example:</p> <pre>Router# configure terminal</pre>	<p>Enters global configuration mode.</p>
<p>Step 3 policy-map <i>policy-map-name</i></p> <p>Example:</p> <pre>Router(config)# policy-map shape-policy-map</pre>	<p>Creates a policy map that can be attached to one or more interfaces to specify a service policy and enters policy-map configuration mode.</p> <ul style="list-style-type: none"> • The example command creates a policy map named shape-policy-map.
<p>Step 4 class class-default</p> <p>Example:</p> <pre>Router(config-pmap)# class class-default</pre>	<p>Specifies the default class (commonly known as the class-default class) before you configure its policy and enters policy-map class configuration mode.</p> <ul style="list-style-type: none"> • The class-default class is the class to which traffic is directed if that traffic does not satisfy the match criteria of other classes whose policy is defined in the policy map. • Only one class is defined with this command (the class-default class); therefore, it will match all traffic.

Command or Action	Purpose
Step 5 <code>service-policy policy-map-name</code> Example: <pre>Router(config-pmap-c)# service-policy llq</pre>	Attaches a service policy as a traffic shaping policy within a policy map. <ul style="list-style-type: none"> This parent-child service policy association is called a hierarchical service policy. The example command creates a hierarchical service policy with the parent policy map being "shape-policy-map", and the child policy map being "llq".
Step 6 <code>end</code> Example: <pre>Router(config-pmap-c)# end</pre>	(Optional) Exits policy-map class configuration mode and returns to privileged EXEC mode.

Specifying a Map Class and Attaching a Service Policy for the PVC

To specify a map class and attach a service policy for the PVC, use the following commands.

SUMMARY STEPS

1. `enable`
2. `configure terminal`
3. `map-class frame-relay map-class-name`
4. `service-policy {input | output} policy-map-name`
5. `end`

DETAILED STEPS

Command or Action	Purpose
Step 1 <code>enable</code> Example: <pre>Router> enable</pre>	Enables privileged EXEC mode. <ul style="list-style-type: none"> Enter your password if prompted.
Step 2 <code>configure terminal</code> Example: <pre>Router# configure terminal</pre>	Enters global configuration mode.

Command or Action	Purpose
<p>Step 3 <code>map-class frame-relay <i>map-class-name</i></code></p> <p>Example:</p> <pre>Router (config)# map-class frame-relay shape-map-class</pre>	<p>Specifies a map class to define fragmentation values for both a PVC and a MQC policy map attachment and enters static maps class configuration mode.</p> <ul style="list-style-type: none"> The example command specifies a map class named <code>shape-map-class</code>.
<p>Step 4 <code>service-policy {input output} <i>policy-map-name</i></code></p> <p>Example:</p> <pre>Router(config-map-class)# service-policy input shape-policy-map</pre>	<p>Attaches a service policy for a PVC.</p>
<p>Step 5 <code>end</code></p> <p>Example:</p> <pre>Router(config-map-class)# end</pre>	<p>(Optional) Exits static maps class configuration mode and returns to privileged EXEC mode.</p>

Configuring an Interface or Subinterface for Frame Relay and Associating a Map Class with a PVC

To configure an interface or subinterface for Frame Relay and associate a map class with a PVC, use the following commands.

SUMMARY STEPS

- `enable`
- `configure terminal`
- `interface type number [name-tag]`
- `encapsulation frame-relay [MFR | ietf]`
- `exit`
- `interface type slot / port . subinterface-number [multipoint | point-to-point]`
- `ip address ip-address mask [secondary]`
- `frame-relay interface-dlci dlci [ietf | cisco]`
- `class name`
- `end`

DETAILED STEPS

	Command or Action	Purpose
Step 1	<p>enable</p> <p>Example:</p> <pre>Router> enable</pre>	<p>Enables privileged EXEC mode.</p> <ul style="list-style-type: none"> Enter your password if prompted.
Step 2	<p>configure terminal</p> <p>Example:</p> <pre>Router# configure terminal</pre>	<p>Enters global configuration mode.</p>
Step 3	<p>interface <i>type number</i> [<i>name-tag</i>]</p> <p>Example:</p> <pre>Router(config)# interface serial 0/0</pre>	<p>Configures an interface type and enters interface configuration mode.</p>
Step 4	<p>encapsulation frame-relay [MFR ietf]</p> <p>Example:</p> <pre>Router(config-if)# encapsulation frame-relay</pre>	<p>Enables Frame Relay encapsulation.</p>
Step 5	<p>exit</p> <p>Example:</p> <pre>Router(config-if)# exit</pre>	<p>Exits interface configuration mode and returns to global configuration mode.</p>
Step 6	<p>interface <i>type slot / port . subinterface-number</i> [multipoint point-to-point]</p> <p>Example:</p> <pre>Router(config)# interface serial 0/0.1 point-to-point</pre>	<p>Configures a subinterface and enters subinterface configuration mode.</p>
Step 7	<p>ip address <i>ip-address mask</i> [secondary]</p> <p>Example:</p> <pre>Router(config-subif)# ip address 192.168.1.1 255.255.255.0</pre>	<p>Sets the primary IP address and mask for the subinterface.</p>

	Command or Action	Purpose
Step 8	frame-relay interface-dlci <i>dlci</i> [<i>ietf</i> <i>cisco</i>] Example: <pre>Router(config-subif)# frame-relay interface-dlci 100</pre>	Assigns a data-link connection identifier (DLCI) to a specified Frame Relay subinterface on the router and enters Frame Relay DLCI configuration mode. <ul style="list-style-type: none"> The example command creates a PVC with a DLCI number of 100 under serial 0/0.1 subinterface.
Step 9	class <i>name</i> Example: <pre>Router(config-fr-dlci)# class shape-map-class</pre>	Associates a map class with the subinterface. <ul style="list-style-type: none"> The example command associates the map class named <code>shape-map-class</code> with the PVC created in Configuring an Interface or Subinterface for Frame Relay and Associating a Map Class with a PVC, page 199.
Step 10	end Example: <pre>Router(config-fr-dlci)# end</pre>	(Optional) Exits Frame Relay DLCI configuration mode and returns to privileged EXEC mode.

Defining Fragmentation Parameters for the PVC

To define fragmentation parameters for the PVC, use the following commands.

SUMMARY STEPS

1. **enable**
2. **configure terminal**
3. **map-class frame-relay** *map-class-name*
4. **frame-relay fragment** *fragment-size* [**switched**]
5. **end**

DETAILED STEPS

	Command or Action	Purpose
Step 1	enable Example: <pre>Router> enable</pre>	Enables privileged EXEC mode. <ul style="list-style-type: none"> Enter your password if prompted.

Command or Action	Purpose
Step 2 configure terminal Example: <pre>Router# configure terminal</pre>	Enters global configuration mode.
Step 3 map-class frame-relay <i>map-class-name</i> Example: <pre>Router (config)# map-class frame-relay shape-map- class</pre>	Specifies a map class to define fragmentation parameters for both a PVC and an MQC policy map attachment and enters static map class configuration mode. <ul style="list-style-type: none"> The example command specifies a map class named shape-map-class.
Step 4 frame-relay fragment <i>fragment-size</i> [switched] Example: <pre>Router(config-map-class)# frame-relay fragment 80</pre>	(Optional) Enables fragmentation of Frame Relay frames for a Frame Relay map class. <ul style="list-style-type: none"> The example command specifies that 80 payload bytes from the original Frame Relay frame will go into each fragment.
Step 5 end Example: <pre>Router(config-map-class)# end</pre>	(Optional) Exits static maps class configuration mode and returns to privileged EXEC mode.

Adding the Policy Map to the Map Class

To add the policy map to the map class, use the following commands.

SUMMARY STEPS

1. **enable**
2. **configure terminal**
3. **policy-map** *policy-map-name*
4. **class** *class-default*
5. **service-policy** *policy-map*
6. **end**

DETAILED STEPS

Command or Action	Purpose
<p>Step 1 <code>enable</code></p> <p>Example:</p> <pre>Router> enable</pre>	<p>Enables privileged EXEC mode.</p> <ul style="list-style-type: none"> Enter your password if prompted.
<p>Step 2 <code>configure terminal</code></p> <p>Example:</p> <pre>Router# configure terminal</pre>	<p>Enters global configuration mode.</p>
<p>Step 3 <code>policy-map <i>policy-map-name</i></code></p> <p>Example:</p> <pre>Router(config)# policy-map shape-policy-map</pre>	<p>Creates a policy map that can be attached to one or more interfaces to specify a service policy and enters policy-map configuration mode.</p> <ul style="list-style-type: none"> The example command creates a policy map named shape-policy-map.
<p>Step 4 <code>class class-default</code></p> <p>Example:</p> <pre>Router(config-pmap)# class class-default</pre>	<p>Specifies the default class (commonly known as the class-default class) before you configure its policy and enters policy-map class configuration mode.</p> <ul style="list-style-type: none"> The class-default class is the class to which traffic is directed if that traffic does not satisfy the match criteria of other classes whose policy is defined in the policy map. Only one class is defined with this command (the class-default class); therefore, it will match all traffic.
<p>Step 5 <code>service-policy <i>policy-map</i></code></p> <p>Example:</p> <pre>Router(config-pmap-c)# service-policy shape-policy-map</pre>	<p>Adds a policy map to a map class and enters policy-map class configuration mode.</p> <ul style="list-style-type: none"> The example command attaches the policy map named shape-policy-map. This command will also attach the policy map shape to any other PVCs that are using the map class.
<p>Step 6 <code>end</code></p> <p>Example:</p> <pre>Router(config-pmap-c)# end</pre>	<p>(Optional) Exits policy-map class configuration mode and returns to privileged EXEC mode.</p>

Configuration Examples for MQC-Based Frame Relay Traffic Shaping

- [Example Configuring Class-Based Weighted Fair Queueing, page 204](#)
- [Example Configuring Class-Based Weighted Fair Queueing with Fragmentation, page 204](#)

Example Configuring Class-Based Weighted Fair Queueing

The following example provides a sample configuration for Class-Based Weighted Fair Queueing (CBWFQ) with FRTS:

```
class-map voice
 match ip dscp ef
policy-map llq
 class voice
  priority 32
policy-map shape-policy-map
 class class-default
  shape average 64000
  shape adaptive 32000
  service-policy llq
map-class frame-relay shape-map-class

service-policy output shape-policy-map
interface serial 0/0
 encapsulation frame-relay
interface serial 0/0.1 point-to-point
 ip address 192.168.1.1 255.255.255.0
 frame-relay interface-dlci 100
 class shape-map-class
```

Example Configuring Class-Based Weighted Fair Queueing with Fragmentation

The following example provides a sample configuration for CBWFQ and fragmentation with FRTS. This configuration example is exactly the same as the example shown in the Example Configuring Class-Based Weighted Fair Queueing section, with the addition of the **frame-relay fragment** command to configure fragmentation.

```
class-map voice
 match ip dscp ef
policy-map llq
 class voice
  priority 32
policy-map shape-policy-map
 class class-default
  shape average 64000
  shape adaptive 32000
  service-policy llq
map-class frame-relay shape-map-class
 frame-relay fragment 80
service-policy output shape-policy-map
interface serial 0/0
 encapsulation frame-relay
interface serial 0/0.1 point-to-point
 ip address 192.168.1.1 255.255.255.0
 frame-relay interface-dlci 100
 class shape-map-class
```

Additional References

Related Documents

Related Topic	Document Title
Cisco IOS commands	Cisco IOS Master Commands List, All Releases
WAN commands	<i>Cisco IOS Wide Area Network Command Reference</i>
MQC commands	Modular Quality of Service Command-Line Interface

Standards

Standard	Title
None	--

MIBs

MIB	MIBs Link
None	To locate and download MIBs for selected platforms, Cisco IOS releases, and feature sets, use Cisco MIB Locator found at the following URL: http://www.cisco.com/go/mibs

Technical Assistance

Description	Link
<p>The Cisco Support website provides extensive online resources, including documentation and tools for troubleshooting and resolving technical issues with Cisco products and technologies.</p> <p>To receive security and technical information about your products, you can subscribe to various services, such as the Product Alert Tool (accessed from Field Notices), the Cisco Technical Services Newsletter, and Really Simple Syndication (RSS) Feeds.</p> <p>Access to most tools on the Cisco Support website requires a Cisco.com user ID and password.</p>	http://www.cisco.com/cisco/web/support/index.html

Feature Information for MQC-Based Frame Relay Traffic Shaping

The following table provides release information about the feature or features described in this module. This table lists only the software release that introduced support for a given feature in a given software release train. Unless noted otherwise, subsequent releases of that software release train also support that feature.

Use Cisco Feature Navigator to find information about platform support and Cisco software image support. To access Cisco Feature Navigator, go to www.cisco.com/go/cfn. An account on Cisco.com is not required.

Table 8 Feature Information for MQC-Based Frame Relay Traffic Shaping

Feature Name	Releases	Feature Information
MQC-Based Frame Relay Traffic Shaping	12.2(13)T	<p>The MQC-Based Frame Relay Traffic Shaping feature provides users with the ability to configure Frame Relay traffic shaping (FRTS) using modular quality of service (QoS) command-line interface (CLI) commands. Modular QoS CLI is known as MQC.</p> <p>The following commands were introduced or modified: shape adaptive, shape fecn-adapt.</p>

Cisco and the Cisco Logo are trademarks of Cisco Systems, Inc. and/or its affiliates in the U.S. and other countries. A listing of Cisco's trademarks can be found at www.cisco.com/go/trademarks. Third party trademarks mentioned are the property of their respective owners. The use of the word partner does not imply a partnership relationship between Cisco and any other company. (1005R)

Any Internet Protocol (IP) addresses and phone numbers used in this document are not intended to be actual addresses and phone numbers. Any examples, command display output, network topology diagrams, and other figures included in the document are shown for illustrative purposes only. Any use of actual IP addresses or phone numbers in illustrative content is unintentional and coincidental.



Frame Relay PVC Interface Priority Queueing

The Frame Relay PVC Interface Priority Queueing feature provides an interface-level priority queueing scheme in which prioritization is based on destination permanent virtual circuit (PVC) rather than packet contents.

- [Finding Feature Information, page 207](#)
- [Feature Overview, page 207](#)
- [Supported Platforms, page 209](#)
- [Supported Standards and MIBs and RFCs, page 209](#)
- [Prerequisites, page 209](#)
- [Configuration Tasks, page 210](#)
- [Monitoring and Maintaining FR PIPQ, page 211](#)
- [Configuration Examples, page 212](#)
- [Glossary, page 213](#)

Finding Feature Information

Your software release may not support all the features documented in this module. For the latest feature information and caveats, see the release notes for your platform and software release. To find information about the features documented in this module, and to see a list of the releases in which each feature is supported, see the Feature Information Table at the end of this document.

Use Cisco Feature Navigator to find information about platform support and Cisco software image support. To access Cisco Feature Navigator, go to www.cisco.com/go/cfn. An account on Cisco.com is not required.

Feature Overview

The FR PIPQ feature provides an interface-level priority queueing scheme in which prioritization is based on destination permanent virtual circuit (PVC) rather than packet contents. For example, FR PIPQ allows you to configure a PVC transporting voice traffic to have absolute priority over a PVC transporting signalling traffic, and a PVC transporting signalling traffic to have absolute priority over a PVC transporting data.

FR PIPQ provides four levels of priority: high, medium, normal, and low. The Frame Relay packet is examined at the interface for the data-link connection identifier (DLCI) value. The packet is then sent to the correct priority queue based on the priority level configured for that DLCI.

**Note**

When using FR PIPQ, configure the network so that different types of traffic are transported on separate PVCs. FR PIPQ is not meant to be used when an individual PVC carries different traffic types that have different quality of service (QoS) requirements.

You assign priority to a PVC within a Frame Relay map class. All PVCs using or inheriting that map class will be classed according to the configured priority. If a PVC does not have a map class associated with it, or if the map class associated with it does not have priority explicitly configured, then the packets on that PVC will be queued on the default "normal" priority queue.

If you do not enable FR PIPQ on the interface using the **frame-relay interface-queue priority** command in interface configuration mode, configuring PVC priority within a map class will not be effective. At this time you have the option to also set the size (in maximum number of packets) of the four priority queues.

FR PIPQ works with or without Frame Relay traffic shaping (FRTS) and FRF.12. The interface-level priority queueing takes the place of the FIFO queueing or dual FIFO queueing normally used by FRTS and FRF.12. PVC priority assigned within FR PIPQ takes precedence over FRF.12 priority, which means that all packets destined for the same PVC will be queued on the same interface queue whether they were fragmented or not.

**Note**

Although high priority PVCs most likely will transport only small packets of voice traffic, you may want to configure FRF.12 on these PVCs anyway to guard against any unexpectedly large packets.

- [Benefits, page 208](#)
- [Restrictions, page 208](#)
- [Related Features and Technologies, page 208](#)
- [Related Documents, page 209](#)

Benefits

FR PIPQ provides four levels of PVC priority: high, medium, normal, and low. This method of queueing ensures that time/delay-sensitive traffic such as voice has absolute priority over signalling traffic, and that signalling traffic has absolute priority over data traffic, providing different PVCs are used for the different types of traffic.

Restrictions

The following restrictions apply to FR PIPQ:

- FR PIPQ is not supported on loopback or tunnel interfaces, or interfaces that explicitly disallow priority queueing.
- FR PIPQ is not supported with hardware compression.
- FR PIPQ cannot be enabled on an interface that is already configured with queueing other than FIFO queueing. FR PIPQ can be enabled if WFQ is configured, as long as WFQ is the default interface queueing method.

Related Features and Technologies

The following features and technologies are related to FR PIPQ:

- FRTS
- FRF.12

Related Documents

The following documents provide information related to FR PIPQ:

- *Cisco IOS Wide-Area Networking Configuration Guide* , Release 12.1
- *Cisco IOS Wide-Area Networking Command Reference* , Release 12.1

Supported Platforms

- Cisco 1000 series
- Cisco 1400 series
- Cisco 1600
- Cisco 1700
- Cisco 1750
- Cisco 2500
- Cisco 2600
- Cisco 3600
- Cisco 3810
- Cisco 4500
- Cisco 4700
- Cisco 7200
- Cisco 7500 (in nondistributed mode)

Supported Standards and MIBs and RFCs

Standards

No new or modified standards are supported by this feature.

MIBs

No new or modified MIBs are supported by this feature.

For descriptions of supported MIBs and how to use MIBs, see the Cisco MIB web site on CCO at <http://www.cisco.com/public/sw-center/netmgmt/cmtk/mibs.shtml>.

RFCs

No new or modified standards are supported by this feature.

Prerequisites

- PVCs should be configured to carry a single type of traffic.

- The network should be configured with adequate call admission control to prevent starvation of any of the priority queues.

Configuration Tasks

- [Configuring PVC Priority in a Map Class](#), page 210
- [Enabling FR PIPQ and Setting Queue Limits](#), page 210
- [Assigning a Map Class to a PVC](#), page 211
- [Verifying FR PIPQ](#), page 211

Configuring PVC Priority in a Map Class

To configure PVC priority within a map class, use the following commands beginning in global configuration mode:

SUMMARY STEPS

1. Router(config)# **map-class frame-relay** *map-class-name*
2. Router(config-map-class)# **frame-relay interface-queue priority** {**high** | **medium**| **normal** | **low**}

DETAILED STEPS

	Command or Action	Purpose
Step 1	Router(config)# map-class frame-relay <i>map-class-name</i>	Specifies a Frame Relay map class.
Step 2	Router(config-map-class)# frame-relay interface-queue priority { high medium normal low }	Assigns a PVC priority level to a Frame Relay map class.

Enabling FR PIPQ and Setting Queue Limits

To enable FR PIPQ and set the priority queue sizes, use the following commands beginning in global configuration mode:

SUMMARY STEPS

1. Router(config)# **interface** *type number* [*name-tag*]
2. Router(config-if)# **encapsulation frame-relay**[**cisco** | **ietf**]
3. Router(config-if)# **frame-relay interface-queue priority** [*high-limit medium-limit normal-limit low-limit*]

DETAILED STEPS

	Command or Action	Purpose
Step 1	Router(config)# interface <i>type number</i> [<i>name-tag</i>]	Configures an interface type and enters interface configuration mode.

	Command or Action	Purpose
Step 2	Router(config-if)# encapsulation frame-relay [cisco ietf]	Enables Frame Relay encapsulation.
Step 3	Router(config-if)# frame-relay interface-queue priority [<i>high-limit medium-limit normal-limit low-limit</i>]	Enables FR PIPQ and sets the priority queue limits.

Assigning a Map Class to a PVC

To assign a map class to a specific PVC, use the following commands beginning in interface configuration mode:

SUMMARY STEPS

1. Router(config-if)# **frame-relay interface-dlci** *dlci*
2. Router(config-fr-dlci)# **class** *map-class-name*

DETAILED STEPS

	Command or Action	Purpose
Step 1	Router(config-if)# frame-relay interface-dlci <i>dlci</i>	Specifies a single PVC on a Frame Relay interface.
Step 2	Router(config-fr-dlci)# class <i>map-class-name</i>	Associates a map class with a specified PVC.

Verifying FR PIPQ

To verify the configuration of FR PIPQ, use one or more of the following commands in privileged EXEC mode:

Command	Purpose
Router# show frame-relay pvc [<i>interface interface</i>] [<i>dlci</i>]	Displays statistics about PVCs for Frame Relay interfaces.
Router# show interfaces [<i>type number</i>] [<i>first</i>] [<i>last</i>]	Displays the statistical information specific to a serial interface.
Router# show queueing [<i>custom</i> <i>fair</i> <i>priority</i> <i>random-detect</i>] [<i>interface atm_subinterface</i>] [<i>vc</i>] [[<i>vpi</i> /] <i>vci</i>]]]	Lists all or selected configured queueing strategies.

Monitoring and Maintaining FR PIPQ

To monitor and maintain FR PIPQ, use one or more of the following commands in privileged EXEC mode:

Command	Purpose
Router# debug priority	Debugs priority output queuing.
Router# show frame-relay pvc [interface interface][<i>dldci</i>]	Displays statistics about PVCs for Frame Relay interfaces.
Router# show interfaces [<i>type number</i>][<i>first</i>][<i>last</i>]	Displays the statistical information specific to a serial interface.
Router# show queue <i>interface-name interface-number</i> [vc [<i>vpi/</i>] <i>vci</i>][<i>queue-number</i>]	Displays the contents of packets inside a queue for a particular interface or VC.
Router# show queuing [custom fair priority random-detect] [interface atm_subinterface [vc [[<i>vpi/</i>] <i>vci</i>]]]	Lists all or selected configured queuing strategies.

Configuration Examples

- [FR PIPQ Configuration Example, page 212](#)

FR PIPQ Configuration Example

This example shows the configuration of four PVCs on serial interface 0. DLCI 100 is assigned high priority, DLCI 200 is assigned medium priority, DLCI 300 is assigned normal priority, and DLCI 400 is assigned low priority.

The following commands configure Frame Relay map classes with PVC priority levels:

```
Router(config)# map-class frame-relay HI
Router(config-map-class)# frame-relay interface-queue priority high
Router(config-map-class)# exit
Router(config)# map-class frame-relay MED
Router(config-map-class)# frame-relay interface-queue priority medium
Router(config-map-class)# exit
Router(config)# map-class frame-relay NORM
Router(config-map-class)# frame-relay interface-queue priority normal
Router(config-map-class)# exit
Router(config)# map-class frame-relay LOW
Router(config-map-class)# frame-relay interface-queue priority low
Router(config-map-class)# exit
```

The following commands enable Frame Relay encapsulation and FR PIPQ on serial interface 0. The sizes of the priority queues are set at a maximum of 20 packets for the high priority queue, 40 for the medium priority queue, 60 for the normal priority queue, and 80 for the low priority queue.

```
Router(config)# interface Serial0
Router(config-if)# encapsulation frame-relay
Router(config-if)# frame-relay interface-queue priority 20 40 60 80
```

The following commands assign priority to four PVCs by associating the DLCIs with the configured map classes:

```
Router(config-if)# frame-relay interface-dlci 100
Router(config-fr-dlci)# class HI
Router(config-fr-dlci)# exit
Router(config-if)# frame-relay interface-dlci 200
Router(config-fr-dlci)# class MED
Router(config-fr-dlci)# exit
Router(config-if)# frame-relay interface-dlci 300
Router(config-fr-dlci)# class NORM
Router(config-fr-dlci)# exit
Router(config-if)# frame-relay interface-dlci 400
Router(config-fr-dlci)# class LOW
Router(config-fr-dlci)# exit
```

Glossary

DLCI --data-link connection identifier. Value that specifies a permanent virtual circuit (PVC) or switched virtual circuit (SVC) in a Frame Relay network.

FIFO queueing -- First-in, first-out queueing. FIFO involves buffering and forwarding of packets in the order of arrival. FIFO embodies no concept of priority or classes of traffic. There is only one queue, and all packets are treated equally. Packets are sent out an interface in the order in which they arrive.

Frame Relay traffic shaping --See FRTS.

FRF.12 --The FRF.12 Implementation Agreement was developed to allow long data frames to be fragmented into smaller pieces and interleaved with real-time frames. In this way, real-time voice and nonreal-time data frames can be carried together on lower-speed links without causing excessive delay to the real-time traffic.

FRTS --Frame Relay traffic shaping. FRTS uses queues on a Frame Relay network to limit surges that can cause congestion. Data is buffered and then sent into the network in regulated amounts to ensure that the traffic will fit within the promised traffic envelope for the particular connection.

PIPQ --Permanent virtual circuit (PVC) interface priority queueing. An interface-level priority queueing scheme in which prioritization is based on destination PVC rather than packet contents.

quality of service --Measure of performance for a transmission system that reflects its transmission quality and service availability.

VoFR --Voice over Frame Relay. Enables a router to carry voice traffic over a Frame Relay network. When voice traffic is sent over Frame Relay, the voice traffic is segmented and encapsulated for transit across the Frame Relay network using FRF.12 encapsulation.

Voice over Frame Relay --See VoFR.

WFQ --weighted fair queueing. Congestion management algorithm that identifies conversations (in the form of traffic streams), separates packets that belong to each conversation, and ensures that capacity is shared fairly among these individual conversations. WFQ is an automatic way of stabilizing network behavior during congestion and results in increased performance and reduced retransmission.

WRED --Weighted Random Early Detection. Combines IP Precedence and standard Random Early Detection (RED) to allow for preferential handling of voice traffic under congestion conditions without exacerbating the congestion. WRED uses and interprets IP Precedence to give priority to voice traffic over data traffic, dropping only data packets.

Cisco and the Cisco Logo are trademarks of Cisco Systems, Inc. and/or its affiliates in the U.S. and other countries. A listing of Cisco's trademarks can be found at www.cisco.com/go/trademarks. Third party trademarks mentioned are the property of their respective owners. The use of the word partner does not imply a partnership relationship between Cisco and any other company. (1005R)

Any Internet Protocol (IP) addresses and phone numbers used in this document are not intended to be actual addresses and phone numbers. Any examples, command display output, network topology diagrams, and other figures included in the document are shown for illustrative purposes only. Any use of actual IP addresses or phone numbers in illustrative content is unintentional and coincidental.



Multilink Frame Relay FRF.16.1

The Multilink Frame Relay (FRF.16.1) feature introduces functionality based on the Frame Relay Forum Multilink Frame Relay UNI/NNI Implementation Agreement (FRF.16.1). This feature provides a cost-effective way to increase bandwidth for particular applications by enabling multiple serial links to be aggregated into a single bundle of bandwidth. Multilink Frame Relay (MFR) is supported on User-to-Network Interfaces (UNI) and Network-to-Network Interfaces (NNI) in Frame Relay networks.

- [Finding Feature Information, page 215](#)
- [Prerequisites for Multilink Frame Relay FRF.16.1, page 215](#)
- [Restrictions for Multilink Frame Relay FRF.16.1, page 215](#)
- [Information About Multilink Frame Relay FRF.16.1, page 216](#)
- [How to Enable Multilink Frame Relay FRF.16.1, page 217](#)
- [Configuration Examples for Multilink Frame Relay FRF.16.1, page 225](#)
- [Additional References, page 226](#)
- [Feature Information for Multilink Frame Relay FRF.16.1, page 227](#)
- [Glossary, page 228](#)

Finding Feature Information

Your software release may not support all the features documented in this module. For the latest feature information and caveats, see the release notes for your platform and software release. To find information about the features documented in this module, and to see a list of the releases in which each feature is supported, see the Feature Information Table at the end of this document.

Use Cisco Feature Navigator to find information about platform support and Cisco software image support. To access Cisco Feature Navigator, go to www.cisco.com/go/cfn. An account on Cisco.com is not required.

Prerequisites for Multilink Frame Relay FRF.16.1

- Multilink Frame Relay must be configured on the peer device.

Restrictions for Multilink Frame Relay FRF.16.1

- ISDN interfaces and any type of virtual interface cannot be a bundle link.
- Frame Relay fragmentation (FRF.12) is not supported in Cisco IOS releases 12.0(17)S, 12.2(8)T, and 12.2(14)S.

- The multilink Frame Relay MIB (RFC 3020) is not supported.
- FRF.9 hardware compression over multilink Frame Relay is not supported.

Information About Multilink Frame Relay FRF.16.1

- [Benefits of Multilink Frame Relay FRF.16.1, page 216](#)
- [Link Integrity Protocol Control Messages, page 216](#)
- [Variable Bandwidth Class Support, page 216](#)
- [Load Balancing with Multilink Frame Relay FRF.16.1, page 217](#)

Benefits of Multilink Frame Relay FRF.16.1

Flexible Pool of Bandwidth

By combining multiple physical interfaces into a bundle, you can design a Frame Relay interface that has more bandwidth than is available from any single physical interface. For example, many new network applications require more bandwidth than is available on a T1 line. One option is to invest in a T3 line; however, T3 lines can be expensive and are not available in some locations. Multilink Frame Relay provides a cost-effective solution to this problem by allowing multiple T1 lines to be aggregated into a single bundle of bandwidth.

Greater Service Resilience When Links Fail

Greater service resilience is provided when multiple physical interfaces are provisioned as a single bundle. When a link fails, the bundle continues to support the Frame Relay service by transmitting across the remaining bundle links.

Link Integrity Protocol Control Messages

For link management, each end of a bundle link follows the MFR Link Integrity Protocol and exchanges link-control messages with its peer (the other end of the bundle link). For a bundle link to be brought up, each end of the link must complete an exchange of ADD_LINK and ADD_LINK_ACK messages. To maintain the link, both ends periodically initiate the exchange of HELLO and HELLO_ACK messages. This exchange of hello messages and acknowledgments serves as a keepalive mechanism for the link. If a router is sending hello messages but not receiving acknowledgments, it will resend the hello message up to a configured maximum number of times. If the router exhausts the maximum number of retries, the bundle link line protocol is considered down (nonoperational).

The bundle link interface's line protocol status is considered up (operational) when the peer device acknowledges that it will use the same link for the bundle. The line protocol remains up when the peer device acknowledges the hello messages from the local router.

The bundle interface's line protocol status is considered up when the Frame Relay data-link layer at the local router and peer device is synchronized using the Local Management Interface (LMI), when LMI is enabled. The bundle line protocol remains up as long as the LMI keepalives are successful.

Variable Bandwidth Class Support

Multilink Frame Relay (FRF.16.1) variable bandwidth class support allows you to specify the criterion used to activate or deactivate a Frame Relay bundle. Consistent with the Frame Relay Forum Multilink

Frame Relay UNI/NNI Implementation Agreement (FRF.16.1), bandwidth classes A (single link), B (all links), and C (threshold) are supported.

Class A (Single Link)

The Frame Relay bundle is provisioned when one or more bundle links indicate by issuing a BL_ACTIVATE message that operational bandwidth is available. When this occurs, the bundle emulates a physical link by issuing a PH_ACTIVATE message to the data-link layer.

When the operational bandwidth of a bundle link fails to meet operational requirements (for instance, if it is in rollback mode), the bundle link issues a BL_DEACTIVATE message. When all bundle links are down in a class A bundle, a PH_DEACTIVATE message is sent to the data-link layer, indicating that the Frame Relay bundle cannot accept frames.

Class B (All Links)

The Frame Relay bundle is provisioned when all bundle links indicate by issuing a BL_ACTIVATE message that operational bandwidth is available. When this occurs, the bundle emulates a physical link by issuing a PH_ACTIVATE message to the data-link layer.

When the operational bandwidth of a bundle link fails to meet operational requirements (for instance, if it is in loopback mode), the bundle link issues a BL_DEACTIVATE message. When any bundle link is down in a class B bundle, a PH_DEACTIVATE message is sent to the data-link layer, indicating that the Frame Relay bundle cannot accept frames.

Class C (Threshold)

The Frame Relay bundle is provisioned when the minimum number of links in the configured bundle issue a BL_ACTIVATE message. When this occurs, the bundle emulates a physical link by issuing a PH_ACTIVATE message to the data-link layer.

When the number of bundle links that are issuing a BL_ACTIVATE message falls below the configured threshold value, a PH_DEACTIVATE message is sent to the data-link layer, indicating that the Frame Relay bundle cannot accept frames.

Load Balancing with Multilink Frame Relay FRF.16.1

Multilink Frame Relay provides load balancing across the bundle links within a bundle. If a bundle link chosen for transmission happens to be busy transmitting a long packet, the load-balancing mechanism can try another link, thus solving the problems seen when delay-sensitive packets have to wait.

How to Enable Multilink Frame Relay FRF.16.1

- [Configuring a Multilink Frame Relay Bundle](#), page 217
- [Configuring a Multilink Frame Relay Bundle Link](#), page 221
- [Monitoring and Maintaining Multilink Frame Relay FRF.16.1](#), page 223

Configuring a Multilink Frame Relay Bundle

To configure the bundle interface for multilink Frame Relay, perform the steps in this section.

SUMMARY STEPS

1. **enable**
2. **configure terminal**
3. **interface mfr** *interface-number*
4. Do one of the following:
 - **frame-relay multilink bandwidth-class** [a | b | c [*threshold*]]
5. **frame-relay intf-type** *dce*
6. **frame-relay multilink bid** *name*
7. **frame-relay multilink output-threshold** *bytes*
8. **interface mfr** *interface-number . subinterface-number* **point-to-point**
9. **ip address** *ip-address mask*
10. **frame-relay interface-dlci** *dlci*
11. **end**
12. **show frame-relay multilink**

DETAILED STEPS

	Command or Action	Purpose
Step 1	enable Example: Router> enable	Enables privileged EXEC mode. <ul style="list-style-type: none"> • Enter your password if prompted.
Step 2	configure terminal Example: Router# configure terminal	Enters global configuration mode.
Step 3	interface mfr <i>interface-number</i> Example: Router(config)# interface mfr mfr1	Configures a multilink Frame Relay bundle interface.

Command or Action	Purpose
<p>Step 4 Do one of the following:</p> <ul style="list-style-type: none"> • frame-relay multilink bandwidth-class [a b c [<i>threshold</i>]] <p>Example:</p> <pre>Router(config-if)# frame-relay multilink bandwidth-class a</pre> <p>Example:</p> <p>Example:</p> <pre>Router(config-if)# frame-relay multilink bandwidth-class b</pre> <p>Example:</p> <pre>Router(config-if)# frame-relay multilink bandwidth-class c 3</pre>	<p>(Optional) Specifies the bandwidth class criterion used to activate or deactivate a Frame Relay bundle.</p> <ul style="list-style-type: none"> • Class A (single link)--The bundle will activate when any bundle link is up and will deactivate when all bundle links are down (default). • Class B (all links)--The bundle will activate when all bundle links are up and will deactivate when any bundle link is down. • Class C (threshold)--The bundle will activate when the minimum configured number of bundle links is up (the threshold) and will deactivate when the minimum number of configured bundle links fails to meet the threshold. <p>Note If no bandwidth class criterion is specified by using the frame-relay multilink bandwidth-class command, the Frame Relay bundle will default to class A (single link).</p>
<p>Step 5 frame-relay intf-type dce</p> <p>Example:</p> <pre>Router(config-if)# frame-relay intf- type dce</pre>	<p>Configures a device to function as the data circuit-terminating equipment (DCE).</p> <ul style="list-style-type: none"> • Only one end of a link should be configured as the DCE. The other end will function as the data terminal equipment (DTE), which is the default setting. • This command can be used only if Frame Relay switching has been enabled by entering the frame-relay switching command in global configuration mode.

Command or Action	Purpose
<p>Step 6 <code>frame-relay multilink bid <i>name</i></code></p> <p>Example:</p> <pre>Router(config-if)# frame-relay multilink bid router1</pre>	<p>(Optional) Assigns a bundle identification name to a multilink Frame Relay bundle.</p> <ul style="list-style-type: none"> The bundle identification (BID) will not go into effect until the interface has gone from the "down" state to the "up" state. One way to bring the interface down and back up again is by using the shutdown and no shutdown commands in interface configuration mode.
<p>Step 7 <code>frame-relay multilink output-threshold <i>bytes</i></code></p> <p>Example:</p> <pre>Router(config-if)# frame-relay multilink output-threshold 500</pre>	<p>(Optional) Configures the number of bytes that a bundle link will transmit before the load-balancing mechanism causes transmission to roll over to the next available link.</p> <ul style="list-style-type: none"> When configured on the bundle interface, this command applies to all bundle links in the bundle.
<p>Step 8 <code>interface mfr <i>interface-number . subinterface-number point-to-point</i></code></p> <p>Example:</p> <pre>Router(config-if)# interface mfr1.1 point-to-point</pre>	<p>Configures a point-to-point multilink Frame Relay subinterface.</p>
<p>Step 9 <code>ip address <i>ip-address mask</i></code></p> <p>Example:</p> <pre>Router(config-subif)# ip address 10.0.1.1 255.255.255.0</pre>	<p>Configures the IP address for the subinterface.</p>
<p>Step 10 <code>frame-relay interface-dlci <i>dlci</i></code></p> <p>Example:</p> <pre>Router(config-subif)# frame-relay interface-dlci 100</pre>	<p>Assigns a data-link connection identifier (DLCI) to a Frame Relay subinterface.</p>
<p>Step 11 <code>end</code></p> <p>Example:</p> <pre>Router(config-subif)# end</pre>	<p>Ends the configuration session and returns to privileged EXEC mode.</p>

Command or Action	Purpose
Step 12 <code>show frame-relay multilink</code> Example: Router# <code>show frame-relay multilink</code>	(Optional) Displays the current Frame Relay multilink configuration.

Configuring a Multilink Frame Relay Bundle Link

To configure a bundle link interface for multilink Frame Relay, perform the steps in this section.



Tip

To minimize latency that results from the arrival order of packets, we recommend bundling physical links of the same line speed in one bundle.

SUMMARY STEPS

1. `enable`
2. `configure terminal`
3. `interface serial number`
4. `encapsulation frame-relay mfr number [name]`
5. `frame-relay multilink output-threshold bytes`
6. `frame-relay multilink lid name`
7. `frame-relay multilink hello seconds`
8. `frame-relay multilink ack seconds`
9. `frame-relay multilink retry number`
10. `end`
11. `show frame-relay multilink`

DETAILED STEPS

Command or Action	Purpose
Step 1 <code>enable</code> Example: Router> <code>enable</code>	Enables privileged EXEC mode. <ul style="list-style-type: none"> • Enter your password if prompted.

Command or Action	Purpose
<p>Step 2 <code>configure terminal</code></p> <p>Example:</p> <pre>Router# configure terminal</pre>	<p>Enters global configuration mode.</p>
<p>Step 3 <code>interface serial <i>number</i></code></p> <p>Example:</p> <pre>Router(config)# interface serial 5/0</pre>	<p>Selects a physical interface and enters interface configuration mode.</p>
<p>Step 4 <code>encapsulation frame-relay mfr <i>number</i> [<i>name</i>]</code></p> <p>Example:</p> <pre>Router(config-if)# encapsulation frame-relay mfr1</pre>	<p>Creates a multilink Frame Relay bundle link and associates the link with a bundle.</p>
<p>Step 5 <code>frame-relay multilink output-threshold <i>bytes</i></code></p> <p>Example:</p> <pre>Router(config-if)# frame-relay multilink output-threshold 500</pre>	<p>(Optional) Configures the number of bytes that a bundle link will transmit before the load-balancing mechanism causes transmission to roll over to the next available link.</p>
<p>Step 6 <code>frame-relay multilink lid <i>name</i></code></p> <p>Example:</p> <pre>Router(config-if)# frame-relay multilink lid first-link</pre>	<p>(Optional) Assigns a bundle link identification name with a multilink Frame Relay bundle link.</p> <ul style="list-style-type: none"> The bundle link identification (LID) will not go into effect until the interface has gone from the "down" state to the "up" state. One way to bring the interface down and back up again is by using the shutdown and no shutdown commands in interface configuration mode.
<p>Step 7 <code>frame-relay multilink hello <i>seconds</i></code></p> <p>Example:</p> <pre>Router(config-if)# frame-relay multilink hello 9</pre>	<p>(Optional) Configures the interval at which a bundle link will send out hello messages.</p> <ul style="list-style-type: none"> The default value is 10 seconds.
<p>Step 8 <code>frame-relay multilink ack <i>seconds</i></code></p> <p>Example:</p> <pre>Router(config-if)# frame-relay multilink ack 6</pre>	<p>(Optional) Configures the number of seconds that a bundle link will wait for a hello message acknowledgment before resending the hello message.</p> <ul style="list-style-type: none"> The default value is 4 seconds.

	Command or Action	Purpose
Step 9	frame-relay multilink retry <i>number</i> Example: <pre>Router(config-if)# frame-relay multilink retry 3</pre>	(Optional) Configures the maximum number of times that a bundle link will resend a hello message while waiting for an acknowledgment. <ul style="list-style-type: none"> The default value is 2 tries.
Step 10	end Example: <pre>Router(config-if)# end</pre>	Ends the configuration session and returns to privileged EXEC mode.
Step 11	show frame-relay multilink Example: <pre>Router# show frame-relay multilink</pre>	(Optional) Displays the current Frame Relay multilink configuration.

Monitoring and Maintaining Multilink Frame Relay FRF.16.1

To monitor and maintain multilink Frame Relay, perform the steps in this section.

SUMMARY STEPS

- enable
- debug frame-relay multilink [control [mfr *number* | serial *number*]]
- show frame-relay multilink [mfr *number* | serial *number*] [detailed]
- show interfaces mfr *number*

DETAILED STEPS

	Command or Action	Purpose
Step 1	enable Example: <pre>Router> enable</pre>	Enables privileged EXEC mode. <ul style="list-style-type: none"> Enter your password if prompted.

Command or Action	Purpose
<p>Step 2 <code>debug frame-relay multilink [control [mfr number serial number]]</code></p> <p>Example:</p> <pre>Router# debug frame-relay multilink control mfr1</pre>	(Optional) Displays debug messages for multilink Frame Relay bundles and bundle links.
<p>Step 3 <code>show frame-relay multilink [mfr number serial number] [detailed]</code></p> <p>Example:</p> <pre>Router# show frame-relay multilink mfr1 detailed</pre>	(Optional) Displays configuration information and statistics about multilink Frame Relay bundles and bundle links.
<p>Step 4 <code>show interfaces mfr number</code></p> <p>Example:</p> <pre>Router# show interfaces mfr1</pre>	(Optional) Displays information and packet statistics for the bundle interface.

Examples

The following example shows output for the **show frame-relay multilink** command. Because a particular bundle or bundle link is not specified, information for all bundles and bundle links is displayed:

```
Router# show frame-relay multilink

Bundle: MFR0, state up, class A, no fragmentation
  ID: Bundle-Dallas
  Serial5/1, state up/up, ID: BL-Dallas-1
  Serial5/3, state up/add-sent, ID: BL-Dallas-3
Bundle: MFR1, state down, class B, fragmentation
  ID: Bundle-NewYork#1
  Serial3/0, state up/up, ID: BL-NewYork-1
  Serial3/2, state admin-down/idle, ID: BL-NewYork-2
```

The following example shows output for the **show frame-relay multilink** command when a Frame Relay bundle is configured as bandwidth class C (threshold):

```
Router# show frame-relay multilink

Bundle: MFR0, state down, class C (threshold 3), no fragmentation
  ID: Bundle-Dallas
  Serial5/1, state up/up, ID: BL-Dallas-1
  Serial5/3, state up/add-sent, ID: BL-Dallas-3
```

The following example shows output for the **show frame-relay multilink** command when the **serial number** keyword and argument are specified. It displays information about the specified bundle link:

```
Router# show frame-relay multilink serial 3/2
Bundle links :
Serial3/2, HW state :down, Protocol state :Down_idle, LID :Serial3/2
Bundle interface = MFR0,  BID = MFR0
```

The following examples show output for the **show frame-relay multilink** command when the **serial number** keyword and argument and the **detailed** option are specified. Detailed information about the

specified bundle links is displayed. The first example shows a bundle link in the "idle" state. The second example shows a bundle link in the "up" state:

```
Router# show frame-relay multilink serial 3 detail
Bundle links:
Serial3, HW state = up, link state = Idle, LID = Serial3
Bundle interface = MFR0, BID = MFR0
Cause code = none, Ack timer = 4, Hello timer = 10,
Max retry count = 2, Current count = 0,
Peer LID = Serial5/3, RTT = 0 ms
Statistics:
Add_link sent = 0, Add_link rcv'd = 10,
Add_link ack sent = 0, Add_link ack rcv'd = 0,
Add_link rej sent = 10, Add_link rej rcv'd = 0,
Remove_link sent = 0, Remove_link rcv'd = 0,
Remove_link_ack sent = 0, Remove_link_ack rcv'd = 0,
Hello sent = 0, Hello rcv'd = 0,
Hello_ack sent = 0, Hello_ack rcv'd = 0,
outgoing pak dropped = 0, incoming pak dropped = 0
Router# show frame-relay multilink serial 3 detail
Bundle links:
Serial3, HW state = up, link state = Up, LID = Serial3
Bundle interface = MFR0, BID = MFR0
Cause code = none, Ack timer = 4, Hello timer = 10,
Max retry count = 2, Current count = 0,
Peer LID = Serial5/3, RTT = 4 ms
Statistics:
Add_link sent = 1, Add_link rcv'd = 20,
Add_link ack sent = 1, Add_link ack rcv'd = 1,
Add_link rej sent = 19, Add_link rej rcv'd = 0,
Remove_link sent = 0, Remove_link rcv'd = 0,
Remove_link_ack sent = 0, Remove_link_ack rcv'd = 0,
Hello sent = 0, Hello rcv'd = 1,
Hello_ack sent = 1, Hello_ack rcv'd = 0,
outgoing pak dropped = 0, incoming pak dropped = 0
```

Configuration Examples for Multilink Frame Relay FRF.16.1

- [Configuring Multilink Frame Relay Example, page 225](#)
- [Configuring Variable Bandwidth Class Support Example, page 226](#)

Configuring Multilink Frame Relay Example

The following example shows the configuration of bundle "MFR1." Serial interfaces 5/0 and 6/0 are configured as bundle links:

```
interface MFR1
 no ip address
 mls qos trust dscp
 frame-relay intf-type dce
 frame-relay multilink bid router1
!
interface MFR1.1 point-to-point
 ip address 10.0.1.1 255.255.255.0
 ip pim sparse-mode
 mls qos trust dscp
 frame-relay interface-dlci 100
interface Serial5/0
 encapsulation frame-relay MFR1
 frame-relay multilink lid first-link
 frame-relay multilink hello 9
 frame-relay multilink retry 3
interface Serial6/0
```

```
encapsulation frame-relay MFR1
frame-relay multilink ack 4
```

Configuring Variable Bandwidth Class Support Example

The following example configures the Frame Relay bundle "MFR1" to use the class B (all links) criterion to be activated or deactivated:

```
interface MFR1
ip address 10.1.1.1 255.255.255.0
frame-relay interface-dlci 100
frame-relay multilink bandwidth-class b
```

Additional References

Related Documents

Related Topic	Document Title
Frame Relay configuration	<i>Cisco IOS Wide-Area Networking Configuration Guide , Release 12.4T</i>
Frame Relay commands	<i>Cisco IOS Wide-Area Networking Command Reference, Release 12.4T</i>

Standards

Standard	Title
FRF.16.1	<i>Multilink Frame Relay UNI/NNI Implementation Agreement, May 2002</i>

MIBs

MIB	MIBs Link
None	To locate and download MIBs for selected platforms, Cisco IOS releases, and feature sets, use Cisco MIB Locator found at the following URL: http://www.cisco.com/go/mibs

RFCs

RFC	Title
None	--

Technical Assistance

Description	Link
<p>The Cisco Support website provides extensive online resources, including documentation and tools for troubleshooting and resolving technical issues with Cisco products and technologies.</p> <p>To receive security and technical information about your products, you can subscribe to various services, such as the Product Alert Tool (accessed from Field Notices), the Cisco Technical Services Newsletter, and Really Simple Syndication (RSS) Feeds.</p> <p>Access to most tools on the Cisco Support website requires a Cisco.com user ID and password.</p>	<p>http://www.cisco.com/techsupport</p>

Feature Information for Multilink Frame Relay FRF.16.1

The following table provides release information about the feature or features described in this module. This table lists only the software release that introduced support for a given feature in a given software release train. Unless noted otherwise, subsequent releases of that software release train also support that feature.

Use Cisco Feature Navigator to find information about platform support and Cisco software image support. To access Cisco Feature Navigator, go to www.cisco.com/go/cfn. An account on Cisco.com is not required.

Table 9 Feature Information for Multilink Frame Relay (FRF.16.1)

Feature Name	Releases	Feature Information
Multilink Frame Relay (FRF.16.1)	12.0(17)S 12.2(8)T 12.2(14)S12.2(28)SB 12.2(33)SRA 12.2(31)SB2 12.2(33)SXH	<p>The Multilink Frame Relay (FRF.16.1) feature introduces functionality based on the Frame Relay Forum Multilink Frame Relay UNI/NNI Implementation Agreement (FRF.16.1).</p> <p>In 12.0(17)S, This feature was introduced on the Cisco 12000 series.</p> <p>The following commands were introduced or modified: debug frame-relay multilink, encapsulation frame-relay mfr, frame-relay multilink ack, frame-relay multilink bandwidth-class, frame-relay multilink bid, frame-relay multilink hello, frame-relay multilink lid, frame-relay multilink output-threshold, frame-relay multilink retry, interface mfr, show frame-relay multilink.</p>
Frame Relay fragmentation (FRF.12)	12.3(9) 12.3(11)T 12.2(30)S	<p>Frame Relay Fragmentation based upon FRF.12 allow long data frames to be fragmented into smaller pieces and interleaved with real-time voice frames or other delay-sensitive traffic.</p> <p>In 12.3(9), this feature was introduced.</p>
Multilink Frame Relay (FRF.16.1) - Variable Bandwidth Class	12.0(30)S 12.4(2)T 15.0(1)S	<p>Multilink Frame Relay (FRF.16.1) variable bandwidth class support allows you to specify the criterion used to activate or deactivate a Frame Relay bundle.</p> <p>In 12.0(30)S, this feature was introduced.</p>

Glossary

BID --Bundle identification. The BID is the name used to identify the bundle. The BID can be assigned, or the default can be used.

BL_ACTIVATE --A message that controls the addition of a bundle link to a Frame Relay bundle.

BL_DEACTIVATE --A message that controls the removal a bundle link from a Frame Relay bundle.

bundle --A logical grouping of one or more physical interfaces using the formats and procedures of multilink Frame Relay. A bundle emulates a physical interface to the Frame Relay data-link layer. The bundle is also referred to as the *MFR interface* .

bundle link --An individual physical interface that is a member of a bundle.

DLCI --data-link connection identifier. A value that identifies a permanent virtual circuit (PVC) in a Frame Relay network.

HELLO message --A message that notifies a peer endpoint that the local endpoint is in the operational state (up).

HELLO_ACK --A message that notifies a peer endpoint that a hello message has been received.

LID --link identification. The LID is the name used to identify a bundle link. The LID can be assigned, or the default can be used.

LMI --Local Management Interface. A set of enhancements to the basic Frame Relay specification. LMI includes support for a keepalive mechanism, which verifies that data is flowing; a multicast mechanism, which provides the network server with its local DLCI and the multicast DLCI; global addressing, which gives DLCIs global rather than local significance in Frame Relay networks; and a status mechanism, which provides an ongoing status report on the DLCIs known to the switch.

NNI --Network-to-Network Interface. The interface between two Frame Relay devices that are both located in a private network or both located in a public network.

PH_ACTIVATE --A message that indicates that the Frame Relay bundle is up.

PH_DEACTIVATE --A message that indicates that the Frame Relay bundle is down.

UNI --User-to-Network Interface. The interface between a Frame Relay device in a public network and a Frame Relay device in a private network.

Cisco and the Cisco Logo are trademarks of Cisco Systems, Inc. and/or its affiliates in the U.S. and other countries. A listing of Cisco's trademarks can be found at www.cisco.com/go/trademarks. Third party trademarks mentioned are the property of their respective owners. The use of the word partner does not imply a partnership relationship between Cisco and any other company. (1005R)

Any Internet Protocol (IP) addresses and phone numbers used in this document are not intended to be actual addresses and phone numbers. Any examples, command display output, network topology diagrams, and other figures included in the document are shown for illustrative purposes only. Any use of actual IP addresses or phone numbers in illustrative content is unintentional and coincidental.



Distributed Multilink Frame Relay FRF.16

Feature History

Release	Modification
12.0(24)S	The Distributed Multilink Frame Relay feature was introduced. This feature introduced Multilink Frame Relay (FRF.16) on VIP-enabled Cisco 7500 series routers.
12.3(4)T	This feature on VIP-enabled Cisco 7500 series routers was integrated into Cisco IOS Release 12.3(4)T.

This document describes the Distributed Multilink Frame Relay (dMFR) feature in Cisco IOS Release 12.0(24)S and Cisco IOS Release 12.3(4)T. The dMFR feature introduces MFR on VIP-enabled Cisco 7500 series routers. For information on MFR on other platforms, see the *Multilink Frame Relay (FRF.16)* document.

- [Finding Feature Information, page 231](#)
- [Feature Overview, page 232](#)
- [Supported Platforms, page 234](#)
- [Supported Standards MIBs and RFCs, page 235](#)
- [Prerequisites, page 235](#)
- [Configuration Tasks, page 235](#)
- [Monitoring and Maintaining Distributed Multilink Frame Relay, page 238](#)
- [Configuration Examples, page 239](#)
- [Glossary, page 239](#)

Finding Feature Information

Your software release may not support all the features documented in this module. For the latest feature information and caveats, see the release notes for your platform and software release. To find information about the features documented in this module, and to see a list of the releases in which each feature is supported, see the Feature Information Table at the end of this document.

Use Cisco Feature Navigator to find information about platform support and Cisco software image support. To access Cisco Feature Navigator, go to www.cisco.com/go/cfn. An account on Cisco.com is not required.

Feature Overview

The Distributed Multilink Frame Relay feature introduces functionality based on the Frame Relay Forum Multilink Frame Relay UNI/NNI Implementation Agreement (FRF.16) to VIP-enabled Cisco 7500 series routers. The Distributed Multilink Frame Relay feature provides a cost-effective way to increase bandwidth for particular applications by enabling multiple serial links to be aggregated into a single bundle of bandwidth. Multilink Frame Relay is supported on User-to-Network Interfaces (UNI) and Network-to-Network Interfaces (NNI) in Frame Relay networks.

- [Multilink Frame Relay Bundles and Bundle Links, page 232](#)
- [Link Integrity Protocol Control Messages, page 232](#)
- [Load Balancing, page 233](#)
- [Benefits, page 233](#)
- [Restrictions, page 233](#)
- [Related Documents, page 233](#)

Multilink Frame Relay Bundles and Bundle Links

The Multilink Frame Relay feature enables you to create a virtual interface called a *bundle* or *bundle interface*. The bundle interface emulates a physical interface for the transport of frames. The Frame Relay data link runs on the bundle interface, and Frame Relay virtual circuits are built upon it.

The bundle is made up of multiple serial links, called *bundle links*. Each bundle link within a bundle corresponds to a physical interface. Bundle links are invisible to the Frame Relay data-link layer, so Frame Relay functionality cannot be configured on these interfaces. Regular Frame Relay functionality that you want to apply to these links must be configured on the bundle interface. Bundle links are visible to peer devices. The local router and peer devices exchange link integrity protocol control messages to determine which bundle links are operational and to synchronize which bundle links should be associated with which bundles.

Link Integrity Protocol Control Messages

For link management, each end of a bundle link follows the MFR Link Integrity Protocol and exchanges link control messages with its peer (the other end of the bundle link). To bring up a bundle link, both ends of the link must complete an exchange of ADD_LINK and ADD_LINK_ACK messages. To maintain the link, both ends periodically exchange HELLO and HELLO_ACK messages. This exchange of hello messages and acknowledgments serve as a keepalive mechanism for the link. If a router is sending hello messages but not receiving acknowledgments, it will resend the hello message up to a configured maximum number of times. If the router exhausts the maximum number of retries, the bundle link line protocol is considered down (unoperational).

The bundle link interface's line protocol status is considered up (operational) when the peer device acknowledges that it will use the same link for the bundle. The line protocol remains up when the peer device acknowledges the hello messages from the local router.

The bundle interface's line status becomes up when at least one bundle link has its line protocol status up. The bundle interface's line status goes down when the last bundle link is no longer in the up state. This behavior complies with the class A bandwidth requirement defined in FRF.16.

The bundle interface's line protocol status is considered up when the Frame Relay data-link layer at the local router and peer device synchronize using the Local Management Interface (LMI), when LMI is enabled. The bundle line protocol remains up as long as the LMI keepalives are successful.

Load Balancing

Distributed Multilink Frame Relay provides load balancing across the bundle links within a bundle. If a bundle link chosen for transmission happens to be busy transmitting a long packet, the load balancing mechanism can try another link, thus solving the problems seen when delay-sensitive packets have to wait.

Benefits

Flexible Pool of Bandwidth

By combining multiple physical interfaces into a bundle, you can design a Frame Relay interface with more bandwidth than is available from any single physical interface. For example, many new network applications require more bandwidth than is available on a T1 line. One option is to invest in a T3 line; however, T3 lines can be expensive and are not available in some locations. Distributed Multilink Frame Relay provides a cost-effective solution to this problem by allowing multiple T1 lines to be aggregated into a single bundle of bandwidth.

Greater Service Resilience When Links Fail

Greater service resilience is provided when multiple physical interfaces are provisioned as a single bundle. When a link fails, the bundle continues to support the Frame Relay service by transmitting across the remaining bundle links.

Restrictions

The Distributed Multilink Frame Relay feature has the following restrictions:

- ISDN interfaces and any type of virtual interfaces cannot be a bundle link.
- Distributed CEF is limited to IP traffic only; all other protocols are processed using the Route Switch Processor (RSP).
- Frame Relay fragmentation (FRF.12) is not supported.
- Multilink Frame Relay MIB (RFC 3020) is not supported.
- FRF.9 hardware compression over multilink Frame Relay is not supported.
- Each link in a bundle must reside on the same port adapter and all links in a bundle must have identical configurations. The same bandwidth for each link in the bundle is also recommended because bundles that contain individual links with different bandwidths process packets less efficiently.
- Fragmentation is not supported on the transmitting interface when used in conjunction with Distributed Multilink Frame Relay.
- The maximum differential delay is 50 ms.
- All T1 lines can be combined into one bundle. A VIP2-50 with 4 or 8 MB of SRAM supports up to 16 T1 bundles per VIP and a VIP2-50 with 2 MB of SRAM supports up to 8 T1 bundles per VIP. A maximum of 40 T1 bundles per VIP can be used on a VIP4-80.
- All E1 lines can be combined into one bundle. A VIP2-50 with 4 or 8 MB of SRAM supports up to 12 E1 bundles per VIP and a VIP2-50 with 2 MB or SRAM supports up to 8 E1 bundles per VIP. A maximum of 32 E1 bundles per VIP can be used on a VIP4-80.

Related Documents

- Cisco IOS Wide-Area Networking Configuration Guide , Release 12.3

- Cisco IOS Wide-Area Networking Command Reference , Release 12.3
- Multilink Frame Relay (FRF.16) (provides information on nondistributed Multilink Frame Relay)
- Cisco IOS Release 12.3 T command references (information on 12.0 S and 12.3 T commands)

Supported Platforms

- Cisco 7500 series router with a VIP2-50 or greater

This feature works on the following port adapters:

- - PA-MC-T3
 - PA-MC-2T3+
 - PA-MC-E3
 - PA-MC-2E1
 - PA-MC-2T1
 - PA-MC-4T1
 - PA-MC-8T1
 - PA-MC-8E1
 - PA-MC-STM-1
 - PA-MC-8TE1+
 - PA-4T+
 - PA-8T

Determining Platform Support Through Cisco Feature Navigator

Cisco IOS software is packaged in feature sets that are supported on specific platforms. To get updated information regarding platform support for this feature, access Cisco Feature Navigator. Cisco Feature Navigator dynamically updates the list of supported platforms as new platform support is added for the feature.

Cisco Feature Navigator is a web-based tool that enables you to determine which Cisco IOS software images support a specific set of features and which features are supported in a specific Cisco IOS image. You can search by feature or release. Under the release section, you can compare releases side by side to display both the features unique to each software release and the features in common.

To access Cisco Feature Navigator, you must have an account on Cisco.com. If you have forgotten or lost your account information, send a blank e-mail to cco-locksmith@cisco.com. An automatic check will verify that your e-mail address is registered with Cisco.com. If the check is successful, account details with a new random password will be e-mailed to you. Qualified users can establish an account on Cisco.com by following the directions found at this URL:

<http://www.cisco.com/register> <http://www.cisco.com/register>

Cisco Feature Navigator is updated regularly when major Cisco IOS software releases and technology releases occur. For the most current information, go to the Cisco Feature Navigator home page at the following URL:

<http://www.cisco.com/go/fn>

Availability of Cisco IOS Software Images

Platform support for particular Cisco IOS software releases is dependent on the availability of the software images for those platforms. Software images for some platforms may be deferred, delayed, or changed

without prior notice. For updated information about platform support and availability of software images for each Cisco IOS software release, refer to the online release notes or, if supported, Cisco Feature Navigator.

Supported Standards MIBs and RFCs

Standards

Multilink Frame Relay UNI/NNI Implementation Agreement (FRF.16.1), July 2001

MIBs

No new or modified MIBs are supported by this feature.

To locate and download MIBs for selected platforms, Cisco IOS releases, and feature sets, use Cisco MIB Locator found at the following URL:

<http://tools.cisco.com/TTDIT/MIBS/servlet/index>

If Cisco MIB Locator does not support the MIB information that you need, you can also obtain a list of supported MIBs and download MIBs from the Cisco MIBs page at the following URL:

<http://www.cisco.com/public/sw-center/netmgmt/cmtk/mibs.shtml>

To access Cisco MIB Locator, you must have an account on Cisco.com. If you have forgotten or lost your account information, send a blank e-mail to cco-locksmith@cisco.com. An automatic check will verify that your e-mail address is registered with Cisco.com. If the check is successful, account details with a new random password will be e-mailed to you. Qualified users can establish an account on Cisco.com by following the directions found at this URL:

<http://www.cisco.com/register>

RFCs

No new or modified RFCs are supported by this feature.

Prerequisites

- Distributed Cisco Express Forwarding (CEF) must be enabled globally.
- Multilink Frame Relay must be configured on the peer device.
- The multilink Frame Relay peer device must not send frames that require assembly.

Configuration Tasks

- [Configuring a Multilink Frame Relay Bundle](#), page 236
- [Configuring a Multilink Frame Relay Bundle Link](#), page 236
- [Verifying Multilink Frame Relay](#), page 237

Configuring a Multilink Frame Relay Bundle

To configure the bundle interface for Distributed Multilink Frame Relay, use the following commands beginning in global configuration mode:

SUMMARY STEPS

1. Router(config)# **interface mfr** *number*
2. Router(config-if)# **frame-relay multilink bid** *name*

DETAILED STEPS

Command or Action	Purpose
Step 1 Router(config)# interface mfr <i>number</i> Example:	Configures a multilink Frame Relay bundle interface.
Step 2 Router(config-if)# frame-relay multilink bid <i>name</i> Example:	(Optional) Assigns a bundle identification name to a multilink Frame Relay bundle. Note The bundle identification (BID) will not go into effect until the interface has gone from the down state to the up state. One way to bring the interface down and back up again is by using the shut and no shut commands in interface configuration mode.

Configuring a Multilink Frame Relay Bundle Link

To configure a bundle link interface for multilink Frame Relay, use the following commands beginning in global configuration mode:

SUMMARY STEPS

1. Router(config)# **interface serial** *number*
2. Router(config-if)# **encapsulation frame-relay mfr** *number*[*name*]
3. Router(config-if)# **frame-relay multilink lid** *name*
4. Router(config-if)# **frame-relay multilink hello** *seconds*
5. Router(config-if)# **frame-relay multilink ack** *seconds*
6. Router(config-if)# **frame-relay multilink retry** *number*

DETAILED STEPS

Command or Action	Purpose
Step 1 Router(config)# interface serial <i>number</i> Example:	Selects a physical interface and enters interface configuration mode.
Step 2 Router(config-if)# encapsulation frame-relay mfr <i>number[name]</i> Example:	Creates a multilink Frame Relay bundle link and associates the link with a bundle. Tip To minimize latency that results from the arrival order of packets, we recommend bundling physical links of the same line speed in one bundle.
Step 3 Router(config-if)# frame-relay multilink lid <i>name</i> Example:	(Optional) Assigns a bundle link identification name to a multilink Frame Relay bundle link. Note The bundle link identification (LID) will not go into effect until the interface has gone from the down state to the up state. One way to bring the interface down and back up again is by using the shut and no shut commands in interface configuration mode.
Step 4 Router(config-if)# frame-relay multilink hello <i>seconds</i> Example:	(Optional) Configures the interval at which a bundle link will send out hello messages. The default value is 10 seconds.
Step 5 Router(config-if)# frame-relay multilink ack <i>seconds</i> Example:	(Optional) Configures the number of seconds that a bundle link will wait for a hello message acknowledgment before resending the hello message. The default value is 4 seconds.
Step 6 Router(config-if)# frame-relay multilink retry <i>number</i> Example:	(Optional) Configures the maximum number of times a bundle link will resend a hello message while waiting for an acknowledgment. The default value is 2 tries.

Verifying Multilink Frame Relay

To verify multilink Frame Relay configuration, use the **show frame-relay multilink** command.

The following example shows output for the **show frame-relay multilink** command. Because a particular bundle or bundle link is not specified, information for all bundles and bundle links is displayed.

```
Router# show frame-relay multilink
```

```

Bundle: MFR0, state up, class A, no fragmentation
ID: Bundle-Dallas
Serial5/1, state up/up, ID: BL-Dallas-1
Serial5/3, state up/add-sent, ID: BL-Dallas-3
Bundle: MFR1, state down, class B, fragmentation
ID: Bundle-NewYork#1
Serial3/0, state up/up, ID: BL-NewYork-1
Serial3/2, state admin-down/idle, ID: BL-NewYork-2

```

The following example shows output for the **show frame-relay multilink** command with the **serial number** option. It displays information about the specified bundle link.

```

Router# show frame-relay multilink serial3/2
Bundle links :
Serial3/2, HW state :Administratively down, Protocol state :Down_idle, LID :Serial3/2
Bundle interface = MFR0, BID = MFR0

```

The following examples show output for the **show frame-relay multilink** command with the **serial number** and **detail** options. Detailed information about the specified bundle links is displayed. The first example shows a bundle link in the "idle" state. The second example shows a bundle link in the "up" state.

```

Router# show frame-relay multilink serial3 detail
Bundle links:
Serial3, HW state = up, link state = Idle, LID = Serial3
Bundle interface = MFR0, BID = MFR0
Cause code = none, Ack timer = 4, Hello timer = 10,
Max retry count = 2, Current count = 0,
Peer LID = Serial5/3, RTT = 0 ms
Statistics:
Add_link sent = 0, Add_link rcv'd = 10,
Add_link ack sent = 0, Add_link ack rcv'd = 0,
Add_link rej sent = 10, Add_link rej rcv'd = 0,
Remove_link sent = 0, Remove_link rcv'd = 0,
Remove_link_ack sent = 0, Remove_link_ack rcv'd = 0,
Hello sent = 0, Hello rcv'd = 0,
Hello_ack sent = 0, Hello_ack rcv'd = 0,
outgoing pak dropped = 0, incoming pak dropped = 0
Router# show frame-relay multilink serial3 detail
Bundle links:
Serial3, HW state = up, link state = Up, LID = Serial3
Bundle interface = MFR0, BID = MFR0
Cause code = none, Ack timer = 4, Hello timer = 10,
Max retry count = 2, Current count = 0,
Peer LID = Serial5/3, RTT = 4 ms
Statistics:
Add_link sent = 1, Add_link rcv'd = 20,
Add_link ack sent = 1, Add_link ack rcv'd = 1,
Add_link rej sent = 19, Add_link rej rcv'd = 0,
Remove_link sent = 0, Remove_link rcv'd = 0,
Remove_link_ack sent = 0, Remove_link_ack rcv'd = 0,
Hello sent = 0, Hello rcv'd = 1,
Hello_ack sent = 1, Hello_ack rcv'd = 0,
outgoing pak dropped = 0, incoming pak dropped = 0

```

Monitoring and Maintaining Distributed Multilink Frame Relay

To monitor and maintain Distributed Multilink Frame Relay, use one or more of the following commands in privileged EXEC mode:

Command	Purpose
Router# debug frame-relay multilink [control mfr number serial number]	Displays debug messages for multilink Frame Relay bundles and bundle links.
Router# show frame-relay multilink [mfr number serial number] [detailed]	Displays configuration information and statistics about multilink Frame Relay bundles and bundle links.
Router# show interfaces mfr number	Displays information and packet statistics for the bundle interface.

Configuration Examples

- [Distributed Multilink Frame Relay Configuration Example, page 239](#)

Distributed Multilink Frame Relay Configuration Example

The following example shows the configuration of bundle "MFR1". Serial interfaces 5/0 and 6/0 are configured as bundle links.

```
interface MFR1
  frame-relay multilink bid first-bundle
  frame-relay traffic-shaping
  frame-relay class ocean
interface MFR1.1 point-to-point
  ip address 1.1.1.1 255.255.255.0
  frame-relay interface-dlci 100
interface Serial5/0
  encapsulation frame-relay MFR1
  frame-relay multilink lid first-link
  frame-relay multilink hello 9
  frame-relay multilink retry 3
interface Serial6/0
  encapsulation frame-relay MFR1
  frame-relay multilink ack 4
```

Glossary

BID --bundle identification. BID is the name used to identify the bundle. The BID can be assigned or the default can be used.

bundle --A logical grouping of one or more physical interfaces using the formats and procedures of multilink Frame Relay. A bundle emulates a physical interface to the Frame Relay data-link layer. The bundle is also referred to as the *mfr interface* .

bundle link --An individual physical interface that is a member of a bundle.

DLCI --data-link connection identifier. Value that identifies a permanent virtual circuit (PVC) in Frame Relay network.

HELLO message --Message that notifies a peer endpoint that the local endpoint is in the operational state (up).

HELLO_ACK --Message that notifies a peer endpoint that a hello message has been received.

LID --link identification. LID is the name used to identify a bundle link. The LID can be assigned or the default can be used.

LMI --Local Management Interface. Set of enhancements to the basic Frame Relay specification. LMI includes support for a keepalive mechanism, which verifies that data is flowing; a multicast mechanism, which provides the network server with its local DLCI and the multicast DLCI; global addressing, which gives DLCIs global rather than local significance in Frame Relay networks; and a status mechanism, which provides an ongoing status report on the DLCIs known to the switch.

NNI --Network-to-Network Interface. The interface between two Frame Relay devices that are both located in a private network or both located in a public network.

UNI --User-to-Network Interface. The interface between a Frame Relay device in a public network and a Frame Relay device in a private network.

Cisco and the Cisco Logo are trademarks of Cisco Systems, Inc. and/or its affiliates in the U.S. and other countries. A listing of Cisco's trademarks can be found at www.cisco.com/go/trademarks. Third party trademarks mentioned are the property of their respective owners. The use of the word partner does not imply a partnership relationship between Cisco and any other company. (1005R)

Any Internet Protocol (IP) addresses and phone numbers used in this document are not intended to be actual addresses and phone numbers. Any examples, command display output, network topology diagrams, and other figures included in the document are shown for illustrative purposes only. Any use of actual IP addresses or phone numbers in illustrative content is unintentional and coincidental.



Frame Relay show Command and debug Command Enhancements

The Frame Relay show Command and debug Command Enhancements feature provides the ability to filter the output of certain Frame Relay **show** and **debug** commands on the basis of the interface and data-link connection identifier (DLCI). These enhancements facilitate network scalability and simplify network management and troubleshooting.

- [Finding Feature Information, page 241](#)
- [Information About Frame Relay show Command and debug Command Enhancements, page 241](#)
- [Additional References, page 242](#)
- [Feature Information for Frame Relay show Command and debug Command Enhancements, page 243](#)

Finding Feature Information

Your software release may not support all the features documented in this module. For the latest feature information and caveats, see the release notes for your platform and software release. To find information about the features documented in this module, and to see a list of the releases in which each feature is supported, see the Feature Information Table at the end of this document.

Use Cisco Feature Navigator to find information about platform support and Cisco software image support. To access Cisco Feature Navigator, go to www.cisco.com/go/cfn. An account on Cisco.com is not required.

Information About Frame Relay show Command and debug Command Enhancements

- [Overview of the Frame Relay show Command and debug Command Enhancements, page 241](#)
- [Benefits of the Frame Relay Show Command and Debug Command Enhancements, page 242](#)

Overview of the Frame Relay show Command and debug Command Enhancements

This feature introduces the following enhancements:

- The **show frame-relay map** command has been enhanced to allow map information to be displayed for specific interfaces and DLCIs.
- The **show frame-relay ip tcp header-compression** and **show frame-relay ip rtp header-compression** commands have been enhanced to allow header-compression information to be displayed for specific DLCIs.
- The **summary** keyword was added to the **show frame-relay pvc** command, allowing a summary of all PVCs on the system to be displayed.
- Conditional debugging support, which allows debug output to be filtered on the basis of interface and DLCI, was introduced for the following commands:
 - **debug frame-relay end-to-end**
 - **debug frame-relay events**
 - **debug frame-relay fragment**
 - **debug frame-relay fragment event**
 - **debug frame-relay ip**
 - **debug frame-relay ppp**
 - **debug frame-relay verbose**



Note Conditional debugging for Frame Relay **debug** commands is configured by using the **debug condition** command.

Benefits of the Frame Relay Show Command and Debug Command Enhancements

The Frame Relay show Command and debug Command Enhancements allow the output for some Frame Relay **show** commands and **debug** commands to be filtered on the basis of interface and DLCI. This enhancement saves network administrators time and frustration by eliminating the need to look through a large amount of output for information about a specific interface or DLCI. These enhancements can also reduce the amount of CPU processing time that is required to generate large amounts of **show** and **debug** output.

Additional References

Related Documents

Related Topic	Document Title
Cisco IOS XE Wide-Area Networking configuration tasks	<i>Cisco IOS XE Wide-Area Networking Configuration Guide, Release 2</i>
Wide-Area networking commands	<i>Cisco IOS Wide-Area Networking Command Reference</i>

Standards

Standard	Title
None	--

MIBs

MIB	MIBs Link
No new or modified MIBs are supported by this feature, and support for existing MIBs has not been modified by this feature.	To locate and download MIBs for selected platforms, Cisco IOS XE software releases, and feature sets, use Cisco MIB Locator found at the following URL: http://www.cisco.com/go/mibs

RFCs

RFC	Title
None	--

Technical Assistance

Description	Link
The Cisco Support website provides extensive online resources, including documentation and tools for troubleshooting and resolving technical issues with Cisco products and technologies. To receive security and technical information about your products, you can subscribe to various services, such as the Product Alert Tool (accessed from Field Notices), the Cisco Technical Services Newsletter, and Really Simple Syndication (RSS) Feeds. Access to most tools on the Cisco Support website requires a Cisco.com user ID and password.	http://www.cisco.com/cisco/web/support/index.html

Feature Information for Frame Relay show Command and debug Command Enhancements

The following table provides release information about the feature or features described in this module. This table lists only the software release that introduced support for a given feature in a given software release train. Unless noted otherwise, subsequent releases of that software release train also support that feature.

Use Cisco Feature Navigator to find information about platform support and Cisco software image support. To access Cisco Feature Navigator, go to www.cisco.com/go/cfn. An account on Cisco.com is not required.

Table 10 **Feature Information for Frame Relay show Command and debug Command Enhancements**

Feature Name	Releases	Feature Information
Frame Relay show Command and debug Command Enhancements	Cisco IOS XE Release 2.1	The Frame Relay show Command and debug Command Enhancements feature provides the ability to filter the output of certain Frame Relay show and debug commands on the basis of the interface and DLCI.

Cisco and the Cisco Logo are trademarks of Cisco Systems, Inc. and/or its affiliates in the U.S. and other countries. A listing of Cisco's trademarks can be found at www.cisco.com/go/trademarks. Third party trademarks mentioned are the property of their respective owners. The use of the word partner does not imply a partnership relationship between Cisco and any other company. (1005R)

Any Internet Protocol (IP) addresses and phone numbers used in this document are not intended to be actual addresses and phone numbers. Any examples, command display output, network topology diagrams, and other figures included in the document are shown for illustrative purposes only. Any use of actual IP addresses or phone numbers in illustrative content is unintentional and coincidental.



Configuring Frame Relay-ATM Interworking

The Frame Relay-ATM Interworking features enable Frame Relay and ATM networks to exchange data, despite differing network protocols. There are two types of Frame Relay-ATM Interworking:

- [FRF.5 Frame Relay-ATM Network Interworking, page 246](#)
- [FRF.8 Frame Relay-ATM Service Interworking, page 247](#)

For further general information about Frame Relay-ATM Interworking, see the "Wide-Area Networking Overview" chapter at the beginning of this book.

For a description of the commands used to configure Frame Relay-ATM Interworking, refer to the chapter "Frame Relay-ATM Interworking Commands" in the *Cisco IOS Wide-Area Networking Command Reference*. To locate documentation of other commands that appear in this chapter, use the command reference master index or search online.

To identify the hardware platform or software image information associated with a feature, use the Feature Navigator on Cisco.com to search for information about the feature or refer to the software release notes for a specific release. For more information, see the section "Identifying Supported Platforms" in the chapter "Using Cisco IOS Software."

For Cisco IOS Release 12.2, Frame Relay-ATM Interworking is supported on the following platforms and interface types:

- Cisco MC3810: T1/E1 ATM interface
- Cisco 3600 series routers: OC-3 and inverse multiplexing over ATM (IMA) network modules
- Cisco 2600 series routers: OC-3 and IMA network modules
- Cisco 7200 series routers: all Cisco 7200 series ATM interface types
- [Finding Feature Information, page 245](#)
- [Prerequisites, page 246](#)
- [Information About Frame Relay-ATM Interworking, page 246](#)
- [How to Configure Frame Relay-ATM Interworking, page 247](#)
- [Configuration Examples for Frame Relay-ATM Interworking, page 255](#)

Finding Feature Information

Your software release may not support all the features documented in this module. For the latest feature information and caveats, see the release notes for your platform and software release. To find information about the features documented in this module, and to see a list of the releases in which each feature is supported, see the Feature Information Table at the end of this document.

Use Cisco Feature Navigator to find information about platform support and Cisco software image support. To access Cisco Feature Navigator, go to www.cisco.com/go/cfn. An account on Cisco.com is not required.

Prerequisites

If the end station is a Cisco router that is connected to an FRF.8 router or switch in translation mode, you must configure the end station with IETF encapsulation (not Cisco encapsulation, which is the default). To do so, you use the **encapsulation frame relay ietf** command.

IETF encapsulation on the end station is not required for FRF.8 in transparent mode (or for FRF.5 in translation mode or transparent mode). The FRF.5 or FRF.8 router or switch itself does not need IETF encapsulation in translation mode or transparent mode.

Information About Frame Relay-ATM Interworking

- [FRF.5 Frame Relay-ATM Network Interworking](#), page 246
- [FRF.8 Frame Relay-ATM Service Interworking](#), page 247

FRF.5 Frame Relay-ATM Network Interworking

FRF.5 provides network interworking functionality that allows Frame Relay end users to communicate over an intermediate ATM network that supports FRF.5. Multiprotocol encapsulation and other higher-layer procedures are transported transparently, just as they would be over leased lines. The figure below illustrates this concept.

Figure 20 Frame Relay-to-ATM Network Interworking (FRF.5)

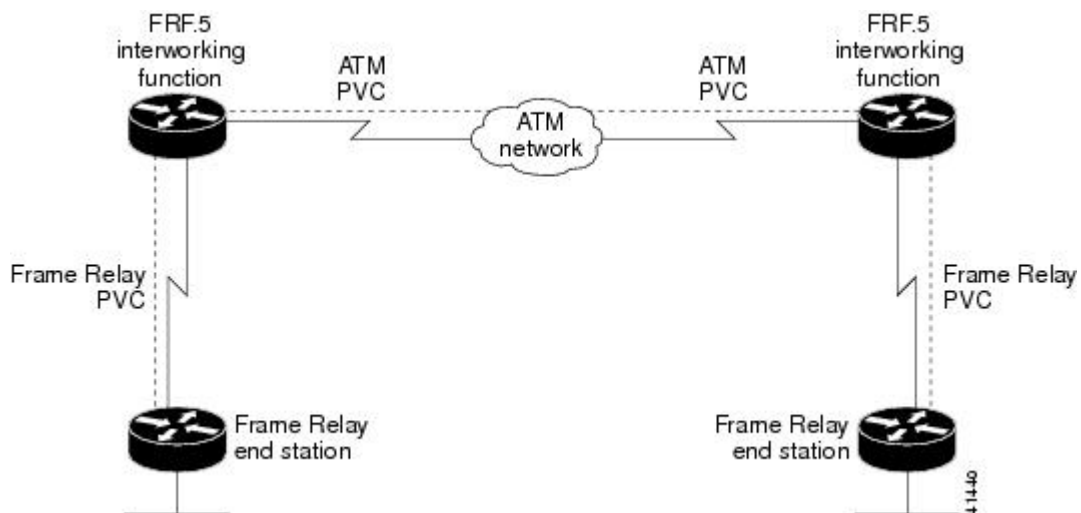

FRF.5 describes network interworking requirements between Frame Relay Bearer Services and Broadband ISDN (BISDN) permanent virtual circuit (PVC) services.

The FRF.5 standard is defined by the Frame Relay Forum Document Number FRF.5: *Frame Relay/ATM PVC Network Interworking Implementation Agreement*. For more information about which sections of this implementation agreement are supported by Cisco IOS software, see the appendix "Frame Relay-ATM Interworking Supported Standards" in this book.

**Note**

On Cisco 7200 series routers, Frame Relay-ATM interworking does not support congestion management bit mapping.

FRF.8 Frame Relay-ATM Service Interworking

FRF.8 provides service interworking functionality that allows a Frame Relay end user to communicate with an ATM end user. Traffic is translated by a protocol converter that provides communication between dissimilar Frame Relay and ATM equipment. The figure below illustrates this concept.

Figure 21 Frame Relay-to-ATM Service Interworking (FRF.8)

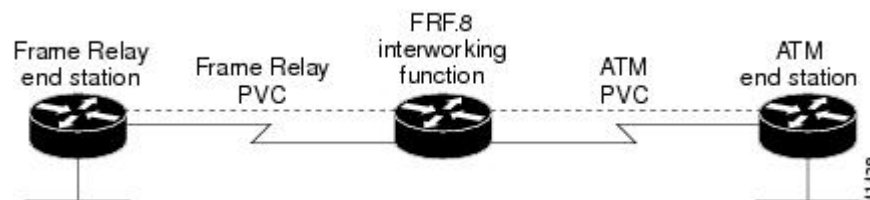

FRF.8 describes a one-to-one mapping between a Frame Relay and an ATM PVC.

The FRF.8 standard is defined by the Frame Relay Forum Document Number FRF.8: *Frame Relay/ATM PVC Network Service Interworking Implementation Agreement*. For more information about which sections of this implementation agreement are supported, see the appendix "Frame Relay-ATM Interworking Supported Standards" in this book.

**Note**

On Cisco 7200 series routers, Frame Relay-ATM interworking does not support congestion management bit mapping.

How to Configure Frame Relay-ATM Interworking

- [Configuring and Verifying FRF.5](#), page 247
- [Configuring and Verifying FRF.8](#), page 251
- [Monitoring and Maintaining Frame Relay-to-ATM Interworking](#), page 255

Configuring and Verifying FRF.5

- [Configuring an FRF.5 One-to-One Network Interworking Connection](#), page 247
- [Configuring an FRF.5 Many-to-One Network Interworking Connection](#), page 249
- [Verifying FRF.5 Configuration](#), page 250

Configuring an FRF.5 One-to-One Network Interworking Connection

To configure FRF.5 encapsulation for a one-to-one connection between two Frame Relay end users over an intermediate ATM network, use the following commands beginning in global configuration mode:

SUMMARY STEPS

1. Router(config)# **interface serial** *number*
2. Router(config-if)# **frame-relay interface-dlci** *dlci* **switched**
3. Router(config)# **interface atm** *number*
4. Router(config-if)# **pvc** [*PVC-name*] *vpi* / *vci*
5. Router(config-if-atm-vc)# **encapsulation aal5mux frame-relay**
6. Router(config)# **connect** *connection-name* *FR-interface* *FR-DLCI* *ATM-interface* *ATM-PVC* **network-interworking**
7. Do one of the following:
 - Router(config-frf5)# **clp-bit** {**0** | **1** | **map-de**}
 -
 -
 - Router(config-frf5)# **de-bit map-clp**
8. Router(config-frf5)# **end**

DETAILED STEPS

	Command or Action	Purpose
Step 1	Router(config)# interface serial <i>number</i>	Configures the Frame Relay interface and enters interface configuration mode.
Step 2	Router(config-if)# frame-relay interface-dlci <i>dlci</i> switched	Configures a switched Frame Relay DLCI.
Step 3	Router(config)# interface atm <i>number</i>	Configures the ATM interface and enters interface configuration mode.
Step 4	Router(config-if)# pvc [<i>PVC-name</i>] <i>vpi</i> / <i>vci</i>	Creates the ATM PVC and virtual path identifier/virtual channel identifier (VPI/VCI). The VCI is a 16-bit field in the header of the ATM cell.
Step 5	Router(config-if-atm-vc)# encapsulation aal5mux frame-relay	Configures the ATM adaption layer (AAL) and encapsulation type for the ATM PVC.
Step 6	Router(config)# connect <i>connection-name</i> <i>FR-interface</i> <i>FR-DLCI</i> <i>ATM-interface</i> <i>ATM-PVC</i> network-interworking	Creates a connection to connect the Frame Relay DLCI to the ATM PVC and configures FRF.5 encapsulation.
Step 7	Do one of the following: <ul style="list-style-type: none"> • Router(config-frf5)# clp-bit {0 1 map-de} • • • Router(config-frf5)# de-bit map-clp 	(On Cisco MC3810, 2600 series, and 3600 series routers only) Sets the ATM cell loss priority (CLP) field in the ATM cell header. (On Cisco MC3810, 2600 series, and 3600 series routers only) Sets discard eligible (DE) bit mapping from ATM to Frame Relay.

Command or Action	Purpose
Step 8 Router(config-frf5)# end	Ends configuration mode and enters EXEC mode. Use the exit command to exit a submode and reenter global configuration command mode.

To disconnect the FRF.5 interworking connection, use the **shutdown** connect subcommand.

Configuring an FRF.5 Many-to-One Network Interworking Connection

To configure FRF.5 encapsulation for a many-to-one connection between two Frame Relay end users over an intermediate ATM network, use the following commands beginning in global configuration command mode:

SUMMARY STEPS

1. Router(config)# **interface serial** *number*
2. Router(config-if)# **frame-relay interface-dlci** *dlci* **switched**
3. Router(config)# **vc-group** *group-name*
4. Router(config-vc-group)# *FR-interface-name* **FR-DLCI**[*FR-SSCS-DLCI*]
5. Router(config)# **interface atm** *number*
6. Router(config-if)# **pvc** [*PVC-name*] *vpi* / *vci*
7. Router(config-if-atm-vc)# **encapsulation aal5mux frame-relay**
8. Router(config)# **connect** *connection-name* **vc-group** *group-name* *ATM-interface* *ATM-vpi/vci*
9. Do one of the following:
 - Router(config-frf5)# **clp-bit** {**0** | **1** | **map-de**}
 -
 -
 -
10. Router(config-frf5)# **end**

DETAILED STEPS

Command or Action	Purpose
Step 1 Router(config)# interface serial <i>number</i>	Configures the Frame Relay interface and enters interface configuration mode.
Step 2 Router(config-if)# frame-relay interface-dlci <i>dlci</i> switched	Configures a switched Frame Relay DLCI.
Step 3 Router(config)# vc-group <i>group-name</i>	Assigns multiple Frame Relay DLCIs to a VC group.
Step 4 Router(config-vc-group)# <i>FR-interface-name</i> FR-DLCI [<i>FR-SSCS-DLCI</i>]	Specifies the Frame Relay DLCIs in the VC group and maps them to the Frame Relay-SSCS DLCIs. If the optional Frame Relay-SSCS DLCI value is not specified, its value will default to 1022.

	Command or Action	Purpose
Step 5	Router(config)# interface atm <i>number</i>	Configures the ATM interface and enters interface configuration mode.
Step 6	Router(config-if)# pvc [<i>PVC-name</i>] <i>vpi / vci</i>	Creates the ATM PVC and VPI/VCI. The VCI is a 16-bit field in the header of the ATM cell.
Step 7	Router(config-if-atm-vc)# encapsulation aal5mux frame-relay	Configures the AAL and encapsulation type for the ATM PVC.
Step 8	Router(config)# connect connection-name vc-group group-name ATM-interface ATM-vpi/vci	Creates a connection to connect the VC group to the ATM PVC.
Step 9	Do one of the following: <ul style="list-style-type: none"> Router(config-frf5)# clp-bit {0 1 map-de} . . . <p>Example:</p> <pre>Router(config-frf5)# de-bit map-clp</pre>	(On Cisco MC3810, 2600 series, and 3600 series routers only) Sets the ATM CLP field in the ATM cell header. (On Cisco MC3810, 2600 series, and 3600 series routers only) Sets DE bit mapping from ATM to Frame Relay.
Step 10	Router(config-frf5)# end	Ends configuration mode and enters EXEC mode. Use the exit command to exit a submode and reenter global configuration command mode.

To disconnect the FRF.5 interworking connection, use the **shutdown** connect subcommand.

Verifying FRF.5 Configuration

To verify correct configuration of the Frame Relay-to-ATM Network Interworking (FRF.5) feature, perform the following tasks:

SUMMARY STEPS

1. Enter the **show connect id** EXEC command to view information, including interworking parameters set, for the specified connection identifier:
2. Enter the **show connect port** EXEC command to view information about the connection on a specific interface:
3. Enter the **show frame-relay pvc**EXEC command to view statistics about Frame Relay interfaces:
4. Enter the **show atm pvc**EXEC command to view ATM PVCs and statistics:

DETAILED STEPS

-
- Step 1** Enter the **show connect id** EXEC command to view information, including interworking parameters set, for the specified connection identifier:

Example:

```
Router# show connect id 5
FR/ATM Network Interworking Connection: network-1
Status      - UP
Segment 1   - VC-Group network-1
Segment 2   - ATM3/0 VPI 1 VCI 34
Interworking Parameters -
  de-bit map-clp
  clp-bit map-de
```

Step 2 Enter the **show connect port EXEC** command to view information about the connection on a specific interface:

Example:

```
Router# show connect port atm3/0
ID   Name                               Segment 1                Segment 2                State
-----
5    network-1                          VC-Group network-1     ATM3/0 1/34             UP
```

Step 3 Enter the **show frame-relay pvcEXEC** command to view statistics about Frame Relay interfaces:

Example:

```
Router# show frame-relay pvc
PVC Statistics for interface Serial1/0 (Frame Relay DCE)
      Active      Inactive      Deleted      Static
Local          0              0              0              0
Switched       1              0              0              0
Unused         0              0              0              0
DLCI = 18, DLCI USAGE = FRF.5, PVC STATUS = ACTIVE, INTERFACE =
Serial1/0
  input pkts 22          output pkts 21          in bytes 2140
  out bytes 2110        dropped pkts 0          in FECN pkts 0
  in BECN pkts 0       out FECN pkts 0       out BECN pkts 0
  in DE pkts 0         out DE pkts 0
  out bcast pkts 0     out bcast bytes 0      Num Pkts
Switched 22
  pvc create time 02:02:49, last time pvc status changed 02:02:42
```

Step 4 Enter the **show atm pvcEXEC** command to view ATM PVCs and statistics:

Example:

```
Router# show atm pvc
Interface  VCD/  Peak  Avg/Min  Burst  Sts
Name      VPI   VCI   Type    Encaps  SC    Kbps   Kbps    Cells
3/0       10    1     32     PVC     FR-ATM  UBR   155000
                                         UP
```

Configuring and Verifying FRF.8

- [Configuring an FRF.8 Service Interworking Connection, page 252](#)
- [Verifying FRF.8 Configuration, page 253](#)

Configuring an FRF.8 Service Interworking Connection

To configure FRF.8 one-to-one protocol mapping between a Frame Relay end user and an ATM end user, use the following commands beginning in global configuration command mode:

SUMMARY STEPS

1. Router(config)# **interface serial** *number*
2. Router(config-if)# **frame-relay interface-dlci** *dlci* **switched**
3. Router(config)# **interface atm** *number*
4. Router(config-if)# **pvc** [*PVC-name*] *vpi* / *vci*
5. Router(config-if)# **encapsulation aal5mux fr-atm-srv**
6. Router(config)# **connect** *connection-name FR-interface FR-DLCI ATM-interface ATM-vpi / vci* **service-interworking**
7. Do one of the following:
 - Router(config-frf8)# **clp-bit** {0 | 1 | **map-de**}
 -
 -
 -
8. Router(config-frf8)# **service translation**
9. Router(config-frf8)# **end**

DETAILED STEPS

	Command or Action	Purpose
Step 1	Router(config)# interface serial <i>number</i>	Configures the Frame Relay interface and enters interface configuration mode.
Step 2	Router(config-if)# frame-relay interface-dlci <i>dlci</i> switched	Configures a switched Frame Relay DLCI.
Step 3	Router(config)# interface atm <i>number</i>	Configures the ATM interface and enters interface configuration mode.
Step 4	Router(config-if)# pvc [<i>PVC-name</i>] <i>vpi</i> / <i>vci</i>	Creates the ATM PVC and virtual path identifier/virtual channel identifier (VPI/VCI). The VCI is a 16-bit field in the header of the ATM cell.
Step 5	Router(config-if)# encapsulation aal5mux fr-atm-srv	Configures the ATM adaption layer (AAL) and encapsulation type for the ATM PVC.
Step 6	Router(config)# connect <i>connection-name FR-interface FR-DLCI ATM-interface ATM-vpi / vci</i> service-interworking	Creates a connection to connect the Frame Relay DLCI to the ATM PVC and configures FRF.8 encapsulation.

Command or Action	Purpose
<p>Step 7 Do one of the following:</p> <ul style="list-style-type: none"> • Router(config-frf8)# clp-bit {0 1 map-de} • • • <p>Example:</p> <pre>Router(config-frf8)# de-bit {0 1 map-clp</pre> <p>Example:</p> <p>Example:</p> <p>Example:</p> <p>Example:</p> <pre>Router(config-frf8)# efcf-bit {0 map-efcn</pre>	<p>(On Cisco MC3810, 2600 series, and 3600 series routers only) Sets the ATM cell loss priority (CLP) field in the ATM cell header.</p> <p>(On Cisco MC3810, 2600 series, and 3600 series routers only) Sets the Frame Relay discard eligible (DE) bit field in the Frame Relay cell header.</p> <p>(On Cisco MC3810, 2600 series, and 3600 series routers only) Sets the explicit forward congestion indication (EFCI) bit field in the ATM cell header.</p>
<p>Step 8 Router(config-frf8)# service translation</p>	<p>Enables upper layer user protocol encapsulation for Frame Relay-to-ATM service interworking.</p>
<p>Step 9 Router(config-frf8)# end</p>	<p>Ends configuration mode and enters EXEC mode.</p> <p>Use the exit command to exit a submode and reenter global configuration command mode.</p>

To disconnect the FRF.8 interworking connection, use the **shutdown** connect subcommand.

Verifying FRF.8 Configuration

To verify correct configuration of the Frame Relay-to-ATM Service Interworking (FRF.8) feature, perform the following tasks:

SUMMARY STEPS

1. Enter the **show connect id** EXEC command to view information, including interworking parameters set, about the specified connection identifier:
2. Enter the **show connect port** EXEC command to view information about the connection on a specific interface:
3. Enter the **show frame-relay pvc** EXEC command to view statistics about Frame Relay interfaces:
4. Enter the **show atm pvc** EXEC command to view ATM PVCs and statistics:

DETAILED STEPS

Step 1 Enter the **show connect id** EXEC command to view information, including interworking parameters set, about the specified connection identifier:

Example:

```
Router# show connect id 10
FR/ATM Service Interworking Connection: service-1
  Status      - UP
  Segment 1 - Serial1/0 DLCI 16
  Segment 2 - ATM3/0 VPI 1 VCI 32
Interworking Parameters -
  service translation
  efcf-bit 0
  de-bit map-clp
  clp-bit map-de
```

Step 2 Enter the **show connect port** EXEC command to view information about the connection on a specific interface:

Example:

```
Router# show connect port atm3/0
ID  Name          Segment 1          Segment 2          State
=====
10  service-1      Serial1/0 16      ATM3/0 1/32      UP
```

Step 3 Enter the **show frame-relay pvc** EXEC command to view statistics about Frame Relay interfaces:

Example:

```
Router# show frame-relay pvc
PVC Statistics for interface Serial1/0 (Frame Relay DCE)
      Active      Inactive      Deleted      Static
Local          0              0              0              0
Switched       1              0              0              0
Unused         0              0              0              0
DLCI = 18, DLCI USAGE = FRF.5, PVC STATUS = ACTIVE, INTERFACE =
Serial1/0
  input pkts 22          output pkts 21          in bytes 2140
  out bytes 2110        dropped pkts 0          in FECN pkts 0
  in BECN pkts 0        out FECN pkts 0        out BECN pkts 0
  in DE pkts 0          out DE pkts 0
  out bcast pkts 0      out bcast bytes 0      Num Pkts
Switched 22
  pvc create time 02:02:49, last time pvc status changed 02:02:42
```

Step 4 Enter the **show atm pvc** EXEC command to view ATM PVCs and statistics:

Example:

```

Router# show atm pvc
          VCD/
Interface Name  VPI  VCI  Type  Encaps  SC      Peak  Avg/Min  Burst  Sts
3/0       10    1   32   PVC    FRATMSRV  UBR   155000

```

Monitoring and Maintaining Frame Relay-to-ATM Interworking

To display the status of the virtual circuits and the Frame Relay-to-ATM interworking connections, use any of the following commands in EXEC mode

Command	Purpose
Router# show atm pvc [signalling interface <i>vcd</i>]	Displays all ATM PVCs, switched virtual circuits (SVCs), and traffic information. Use the signalling keyword to display ATM interface signalling information for all interfaces. Use the interface keyword to display all PVCs and SVCs on the interface or subinterface. Use the <i>vcd</i> argument to specify the ATM VCD number (1-1023) about which to display information.
Router# show connect [all <i>element</i> <i>ID</i> <i>name</i> <i>port</i>]	Displays connection statistics. Use the optional all keyword to display statistics about all connections. Use the optional <i>element</i> , <i>ID</i> , <i>name</i> , and <i>port</i> arguments to display particular connection details.
Router# show frame-relay pvc	Displays statistics about Frame Relay interfaces.
Router# show vc-group	Displays the names of all VC groups.

Configuration Examples for Frame Relay-ATM Interworking

- [FRF.5 One-to-One Connection Example, page 255](#)
- [FRF.5 Many-to-One Connection Example, page 256](#)
- [FRF.8 Service Interworking Example, page 256](#)

FRF.5 One-to-One Connection Example

The following example shows how to configure an FRF.5 one-to-one connection:

```

! Configure a switched Frame Relay DLCI
!
interface serial0
 frame-relay interface-dlci 100 switched
!
! Configure ATM PVC with FRF.5 encapsulation

```

```

!
interface atm3/0
 pvc 0/32
  encapsulation aal5mux frame-relay
!
! Create a connection to connect Frame Relay DLCI 100 to ATM PVC 0/32
!
connect serial0 100 atm3/0 0/32 network-interworking
 clp-bit 1
 de-bit map-clp

```

**Note**

Congestion management parameters are not available for Frame Relay-ATM Interworking on the Cisco 7200 series routers.

FRF.5 Many-to-One Connection Example

The following example shows how to configure an FRF.5 many-to-one connection:

```

! Configure a Frame Relay VC group
!
! The vc-group command assigns Frame Relay DLCI 16, 17, 18,
! and 19 to a VC group named 'friends'.
!
vc-group friends
 serial0 16 16
 serial0 17 17
 serial0 18 18
 serial0 19 19
!
! Configure an ATM PVC with FRF.5 encapsulation
!
interface atm3/0
 pvc 0/32
  encapsulation aal5mux frame-relay
!
! Create a connection which connects VC group 'friends' to ATM PVC 0/32
! and configure FR DE field mapping to match ATM CLP field
!
connect vc-group friends atm3/0 0/32
 de-bit map-clp

```

**Note**

Congestion management parameters are not available for Frame Relay-ATM Interworking on the Cisco 7200 series routers.

FRF.8 Service Interworking Example

The following example shows how to configure an FRF.8 service interworking connection:

```

! Configure a switched Frame Relay DLCI
!
interface serial 0
 frame-relay interface-dlci 100 switched
!
! Configure an ATM PVC with FRF.8 encapsulation
!
interface atm1/0
 pvc 0/32
  encapsulation aal5mux fr-atm-srv
!
! Create a connection that connects Frame Relay DLCI 100 to ATM PVC 1/32

```



```
!  
connect service-1 Serial0 100 ATM3/0 0/32 service-interworking  
efci-bit map-fecn
```

**Note**

Congestion management parameters are not available for Frame Relay-ATM Interworking on the Cisco 7200 series routers.

Cisco and the Cisco Logo are trademarks of Cisco Systems, Inc. and/or its affiliates in the U.S. and other countries. A listing of Cisco's trademarks can be found at www.cisco.com/go/trademarks. Third party trademarks mentioned are the property of their respective owners. The use of the word partner does not imply a partnership relationship between Cisco and any other company. (1005R)

Any Internet Protocol (IP) addresses and phone numbers used in this document are not intended to be actual addresses and phone numbers. Any examples, command display output, network topology diagrams, and other figures included in the document are shown for illustrative purposes only. Any use of actual IP addresses or phone numbers in illustrative content is unintentional and coincidental.

