



V.92 Modem on Hold for Cisco AS5300 and Cisco AS5800 Universal Access Servers

Feature History

Release	Modification
12.2(2)XA	This feature was introduced on Cisco AS5350 and Cisco AS5400 universal gateways running NextPort firmware. This feature was introduced on the Cisco AS5300 universal access server running Cisco MICA Portware Version 2.9.1.0.
12.2(2)XB	This feature was supported with Cisco IOS Release 12.2(2)XB.
12.2(2)XB1	This feature was supported on Cisco AS5800 universal access servers.
12.2(11)T	This feature was integrated into Cisco IOS Release 12.2(11)T and support was added for the Cisco AS5300 and Cisco AS5800 platforms.

This feature module introduces the V.92 International Telecommunication Union Telecommunication Standardization Sector (ITU-T) standard Modem on Hold (MOH) feature with Cisco MICA portware for use with Cisco IOS Release 12.2(2)XB1 and 12.2(11)T.

This document includes the following sections:

- [Feature Overview, page 2](#)
- [Supported Platforms, page 10](#)
- [Supported Standards, MIBs, and RFCs, page 11](#)
- [Prerequisites, page 12](#)
- [Configuration Tasks, page 12](#)
- [Monitoring and Maintaining Modem on Hold, page 12](#)
- [Configuration Examples, page 12](#)
- [Command Reference, page 12](#)
- [Glossary, page 13](#)



Feature Overview

V.92

To remain current with industry needs, the ITU-T V.90 modem standard recommendations have been enhanced. The new standard, V.92, meets the need for a digital modem and analog modem pair on the Public Switched Telephone Network (PSTN). V.92 improves the upstream data signaling rate and adds new features that enhance modem usability.

This feature module introduces the V.92 [Modem on Hold](#) feature on Cisco AS5300 and Cisco AS5800 universal access servers with Cisco MICA Portware Version 2.9.1.0 and higher.

Note

The other feature introduced with the new V.92 standard is V.92 Quick Connect, which is documented in the *V.92 Quick Connect for Cisco AS5300 and Cisco AS5800 Universal Access Servers* feature module. V.92 Modem On Hold and V.92 Quick Connect can be enabled independently of each other.

V.92 is implemented at the modem level as new modem protocols and standards. The new V.92 features co-reside with existing portware features and have no impact on the hardware configuration of either the HMM or DMM (including memory requirements). Cisco IOS software is responsible for controlling the features and displaying the new statistics. V.92 and V.44 support is bound with the rest of the Cisco IOS device driver components.

Note

V.92 is packaged with V.44 in Cisco IOS software. For more information about V.44, refer to the *V.44 LZJH Compression for Cisco AS5300 and Cisco AS5800 Universal Access Servers* feature module.

Note

This feature does not support pulse code modulation (PCM) upstream as defined in the V.92 ITU standard. This feature does, however, interoperate with modems that support PCM upstream.

Modem on Hold

V.92 Modem on Hold allows a dial-in customer to suspend a modem session to answer an incoming voice call or to place an outgoing call while engaged in a modem session. When the dial-in customer uses Modem on Hold to suspend an active modem session to engage in an incoming voice call, the Internet service provider (ISP) modem listens to the original modem connection and waits for the dial-in customer's modem to resume the connection. When the voice call ends, the modem signals the telephone system to end the second call and return to the original modem connection, then the modem signals the ISP modem that it is ready to resume the modem call. Both modems renegotiate the connection, and the original exchange of data continues.

Note

This feature is designed for use on telephone lines that are configured for call-waiting service; call-waiting signals trigger the suspension of the modem session. If call-waiting service is not present on the subscriber's line, callers receive a busy signal, and the modem session is not interrupted.

Figure 1 V.92 Modem on Hold for Cisco AS5300 and Cisco AS5800 Universal Access Servers

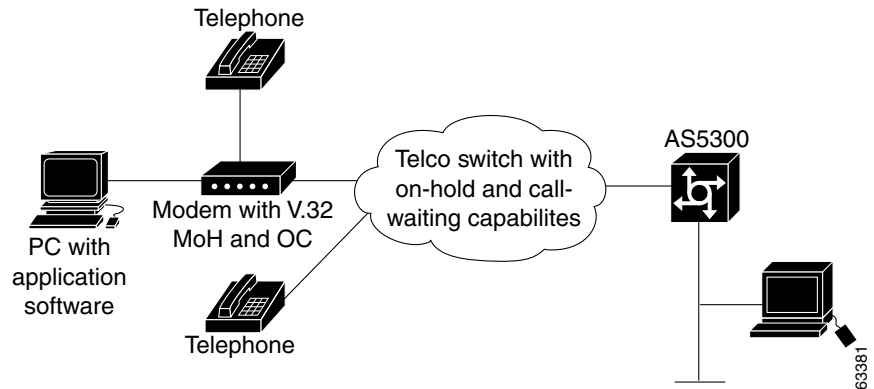

Use of the V.92 Modem on Hold feature for Cisco MICA portware can be controlled globally using AT commands (modemcaps) or can be controlled on a per-caller basis using the RADIUS distributed client/server system.



Note

You are not required to have a RADIUS server to use the Modem on Hold feature.

The following sections contain information about controlling the V.92 Modem on Hold feature:

- [AT Commands \(Modemcaps\) and S-Registers](#)
- [RADIUS Authorization](#)

AT Commands (Modemcaps) and S-Registers

V.92 Modem on Hold is disabled by default and is controlled with standard AT commands and S-registers. V.92 is enabled and disabled with the S29 S-register (S29 = 12), and Modem on Hold is controlled with the S62 S-register (S62 must be set to enable Modem on Hold). AT commands download the configuration to the modem at the end of every call. The **ATSn=v** and **ATSn?** AT commands are used to configure V.92 Modem on Hold on Cisco MICA platforms. Table 1 lists additional S-register parameters used to enable and disable the feature.

To disable V.92 Modem on Hold, you can use a modemcap (for example, s62=0s63=3s21=15s29=12) or set the S29 register to any number other than 12. You can also use the RADIUS vendor-specific attribute (VSA) to disable Modem on Hold if the feature was initially enabled by the default value (modemcap).



Note

If the feature is enabled using S29=12 and Modem on Hold is disabled using S62=0, statistics for the number of times a dial-in customer requests an on-hold are tracked in the MOH link information parameters. However, completely disabling the feature by setting S29 to a value other than 12 disables the reporting of all MOH statistics.

Table 1 V.92 Modem on Hold S-Registers

Name	Register	Index	Default	Description
Modem standard	S29	MICA 19	12 (V.92 enabled)	0 = V.34bis Automode, with V.32ter 1 = V.34bis Automode, without V.32ter 2 = reserved 3 = V.32bis Automode 4 = V.22bis Automode 5 = K56Flex 1.1 Automode 6 = V.90 Automode 7 = MICA:SS7/COT 8 = V.110 9 = Reserved 10 = Reserved 11 = Reserved 12 = V.92 Auto-mode
MOH timeout	S62	MICA 63	0	0: MOH disabled 1: 10 seconds 2: 20 seconds 3: 30 seconds 4: 40 seconds 5: 1 minute 6: 2 minutes 7: 3 minutes 8: 4 minutes 9: 6 minutes 10: 8 minutes 11: 12 minutes 12: 16 minutes 13: No limit

RADIUS Authorization

Per-user control of Modem on Hold can be configured for caller authorization using a RADIUS server. RADIUS servers use the vendor-specific attribute (VSA) capability to configure Modem on Hold for individual users. The current attribute=value protocol syntax has been extended with the new Modem on Hold attribute. You can enter the following value for this attribute:

- An unsigned integer in the range 0 through 65,535—Represents the maximum number of seconds that a modem may remain on hold, which can range from ten seconds to an unlimited number of minutes.

**Note**

Although the integer attribute values can be specified as any value in a contiguous range, V.92 specifications limit configuration to a limited set of values. Attribute values are rounded down to the next permitted value when they are used to configure a modem.

Alternatively, you can enter the **inf** keyword, which allows the modem to remain on hold indefinitely.

If the Modem on Hold configuration is not present, or if it is not syntactically correct, the modem uses its default configuration for Modem on Hold. The default operation can be modified by using a modemcap string. Following authentication of a dial-in user, an additional control command is sent to the modem if the dial-in user does not have a default Modem on Hold configuration.

**Note**

Code space requirements for RADIUS support is less than 2KBs. There are no additional data space requirements.

V.92 Modem on Hold running on systems using RADIUS authorization increases the length of RADIUS response packets by approximately 20 bytes. RADIUS databases increase in size by approximately the same amount for each dial-in user with a nondefault Modem on Hold attribute value.

With RADIUS, authentication and authorization occur as part of the same process. When a caller connects to the access server, the caller enters a user ID and password in response to prompts from the access server. This information is formatted as a RADIUS request packet and is sent to the appropriate RADIUS server. If the user ID is valid and the password matches, the RADIUS server responds with a packet containing authorization data for the connection. This authorization data contains the Modem on Hold configuration if it is present in the RADIUS database.

The access server interprets the response from the RADIUS server and performs any actions associated with the authorization data. For Modem on Hold, a command is sent from the Cisco IOS host to the Cisco MICA channel to set the Modem on Hold parameters. No confirmation from the channel is required.

When the client modem requests a Modem on Hold operation, the modem switches to an on-hold state, which prevents further data from being queued to the connection. When the Cisco IOS software receives the request to go on hold, any transmit packets queued to local Cisco IOS queues (packets not already posted to the queues shared between the Cisco IOS software and the modem) are discarded. This mechanism reduces the possibility that stale data will be transmitted to the modem when the connection is reactivated. It also reduces the number of buffer resources that are tied up while a modem is on hold.

**Note**

When using a RADIUS server, placement of commas is important. The asterisk in the modem-on-hold attribute indicates that the attribute is optional. If a modem does not support Modem on Hold, then the call might continue anyway. If the asterisk is replaced by an "=", the attribute is required, and modems that do not support Modem on Hold terminate the calls following authentication.

The value of the attribute is the number of seconds allowed for the on-hold state. This value is rounded by the Cisco IOS software to one of the permissible values. The number can be replaced with the **inf** command, which allows unlimited on-hold time. Case is significant for both attribute names and values.

**Note**

If your router is configured for RADIUS, the RADIUS server must be accessible to the router. The server must also be capable of responding to authentication requests with VSA attributes.

Configuring V.92 Modem on Hold with RADIUS

If you use Radius to configure the Modem on Hold feature, use the modem-on-hold attribute, where the VALUE attribute is a nonnegative integer in seconds for maximum time on hold allowed. VALUE can be one of the following:

- modem-on-hold=VALUE—MOH support is required for call to be accepted.
- modem-on-hold*VALUE—MOH support is optional.

The following example shows RADIUS enabled where Modem on Hold is optional:

```
vendor-specific=9:1:modem-on-hold*VALUE
```

**Note**

The examples shown below were established on the Cistron open-source server. Your server syntax may vary.

```
# This user can use MOH without time limits. (inf)
# MOH capability is not required for the connection (*)
testi Auth-Type = Local, Password = "test"
Service-Type = Login-User,
Cisco-AVPair = "modem-on-hold*inf"

# This user can use MOH for 30 seconds.
# MOH capability is not required for the connection.
test30 Auth-Type = Local, Password = "test"
Service-Type = Login-User,
Cisco-AVPair = "modem-on-hold*30"

# This user can not use MOH.
# MOH capability is not required for the connection.
test0 Auth-Type = Local, Password = "test"
Service-Type = Login-User,
Cisco-AVPair = "modem-on-hold*0"

# This user can not use MOH.
# But MOH capability IS required for the connection.
# If the user logs on to a device that does not support
# MOH (eg the console), he will be disconnected after
# authentication.
testr Auth-Type = Local, Password = "test"
Service-Type = Login-User,
Cisco-AVPair = "modem-on-hold=0"

# This user gets the default MOH setting.
# The default setting is disabled, unless overridden
# by a modemcap entry.
testx Auth-Type = Local, Password = "test"
Service-Type = Login-User

# This user can go on hold for 60 seconds
# in a PPP link. The service type determines
# which calls get the MOH setting.
lucy Auth-Type = Local, Password = "test"
Service-Type = Framed-User,
```

```
Cisco-AVPair = "modem-on-hold*60"
```

**Note**

The service type defines when the AVPair is applied. For different RADIUS servers, the Cisco-AVPair syntax might be different, but the value in quotes does not change. Case is important: The entire text in quotes must be lowercase.

For more information about using RADIUS, refer to the *Configuring RADIUS* documentation.

Modem Enhancements for V.92 Modem On Hold

The following modem enhancements have been made for the implementation of the V.92 Modem on Hold feature:

- [Disconnect Reasons](#)
- [Duration Limit Timer](#)
- [Modem on Hold Link Information Parameters](#)
- [Modem States](#)
- [New and Modified MIBs](#)

Disconnect Reasons

V.92 Modem on Hold Disconnect Reasons is the method by which a modem tells the Cisco IOS software (host) why it has terminated its session with a client through the Modem on Hold clear-down by modem and the Modem on Hold timeout values. [Table 2](#) lists the new Modem on Hold Disconnect Reasons.

Table 2 **Modem On Hold Disconnect Reasons**

Name	Description
DR_MOH_CLRD	Modem On Hold clear-down by modem
DR_MOH_TIMEOUT	Modem On Hold timeout value reached

Duration Limit Timer

The Modem on Hold duration limit timer is supported within dialed number ID service (DNIS), calling line ID (CLID), RADIUS (but not TACACS+), and global resource pool manager server (RPMS) virtual groups. This support permits ISPs to associate the Modem on Hold feature and its timer limit according to customer needs. When the Modem on Hold timer is active (a modem is on hold), it must take precedence over the idle timer. For example, if the idle value is five minutes and the Modem on Hold duration limit is ten minutes, the customer is permitted to be on another call for up to ten minutes without being disconnected after five minutes by the idle timer. The Modem on Hold timer value resets at the end of each on-hold session.

Modem on Hold Link Information Parameters

Table 3 **Modem on Hold Link Information Parameters**

Name	Description
MOH Status	0: Modem is not on hold 1: Modem is on hold
MOH Count	Number of times the modem is on hold

Table 3 **Modem on Hold Link Information Parameters**

Name	Description
MOH Request Count	Number of times the modem received Modem on Hold requests.
Total MOH Time	Total holding time: 65,535 seconds maximum
Current MOH Time	Current holding time: 65,535 seconds maximum
Call Waiting Retrains	Number of times a retrain occurred due to a call-waiting signal

Modem States

This feature supports modem states, which are discrete states that a modem transitions through, during, and after negotiation with a client modem. These states include the Modem on Hold input state, the Steady input state, and the Steady, Steady Retrain, and Terminate output states.

New and Modified MIBs

Existing MIBs that show the status of modem settings have been extended to show V.92 Modem on Hold configuration status. New MIBs have been created to report the incidence of V.92 Modem on Hold request calls coming into the server and to monitor on-hold status.

Supported Module Firmware and Cisco IOS Software

V.92 Modem on Hold is supported on the following:

- **Module Firmware**—The module firmware is a combination of modem (Digital Signal Processor or DSP) firmware and the module controller firmware. It is responsible for the collection of statistics and the actual implementation of V.92, including additional required state transitions.
- **Cisco IOS software**—The Cisco IOS software is responsible for the control and statistics reporting of the new features, including modemcaps, RADIUS authorization, and command-line interface (CLI) support. See the [“Related Documents” section on page 10](#) for information about new Cisco IOS Release features.
- **Boardware**—On the Cisco AS5300 and Cisco AS5800 with Cisco MICA Portware Version 2.9.1.0 only. The boardware runs on the Amazon carrier card and provides the interface between Cisco IOS and the Cisco MICA module.

Benefits**Allows Voice Calls Without Interruption of Existing Modem Connection**

V.92 Modem on Hold allows the origination and reception of voice calls without disturbing preexisting modem sessions. With Modem on Hold, calls can ring through to the dial-in user without requiring the expense of a second telephone line.

Per-Use Enabling

Service providers can enable Modem on Hold on a per-user basis for premium service opportunities.

Standard Modem Feature

V.92 is a standard modem feature that is offered as a no-cost upgrade to the installed system.

V.92 Compatibility

Modems that support V.92 are fully compatible with modems that do not support it. If a modem that supports Modem on Hold connects with a modem that does not support it, the modems will connect normally. However, the Modem on Hold function is not available for that call.

Restrictions

- Client modem vendors must supply their own utilities to enable Modem on Hold with each client modem.
- There is no standard method for notifying remote or user applications that a modem session has been placed on hold. Extending timeouts or increasing the maximum number of attempts to perform certain operations might be necessary. No e-mail data should be lost because of on-hold times.
- When a Modem on Hold transaction returns to the data-connected state, it retains the same IP network connection. Any other connected applications might not be returned to their prior state, depending on the application's data transaction requirements during the Modem on Hold active state.
- Configuration of these features using S-registers is carried out by using modemcaps (**AT** commands). Cisco IOS software does not check these values to guarantee that they are valid. The behavior of invalid values is determined by the module.
- Authorization of Modem on Hold is not provided as a standard service by RADIUS. However, RADIUS provides a vendor-specific attribute (VSA) capability that can be used to extend authorization mechanisms. This capability is already used by Cisco routers to provide other custom services.
- Cisco IOS software is packaged as multiple program image types with varying capabilities. Because not all modem interfaces support Modem on Hold and because images may be built to support specific modem types, not all software images contain functions to control Modem on Hold. In addition, the modems that do support Modem on Hold implement their control functions differently. Therefore, registry functions are used to interface between RADIUS, local authorization, and Modem on Hold control for modems.
- Server-initiated Modem on Hold is not supported.
- During a suspended modem session, some data might be dropped. The ISP idle timer, which disconnects a dial-in user if there is no data exchanged for a period of time, should be reset and suspended while a connection is on hold.

**Note**

Many client modems used in Europe are known to have problems with the Modem on Hold feature. The vendors are aware of the issue and are working to correct it. If you are having trouble with the Modem on Hold feature in Europe, it is suggested that the customer contact the client modem vendor to verify that the modem complies with the telephony signaling for call waiting, caller ID, and 3-way calling in their particular country.

Related Features and Technologies

- V.92 Quick Connect
- V.44 LZJH data compression service
- Mindspeed CSMv6 hardware solution

Related Documents

- *AT Command Set and Register Summary for MICA Six-Port Modules*
- *Call Tracker plus ISDN and AAA Enhancements for the Cisco AS5300*
- Cisco AS5300 documentation index
- Cisco AS5800 documentation index
- Cisco IOS Release 12.2 Master Indexes
- *Comparing NextPort SPE Commands to MICA Modem Commands*
- New Features in Release 12.2(2)XB
- *Release Notes for Cisco AS5300 Universal Access Servers, Cisco IOS Release 12.2(2)XA*
- *Release Notes for Cisco AS5300 Universal Access Servers, Cisco IOS Release 12.2(2)XB*
- Cisco IOS Release 12.2T Cross-Platform Release Notes
- Cisco AS5800 Universal Access Server Release Notes
- *Release Notes for Cisco MICA Portware Version 2.9.1.0 on Cisco AS5300 Universal Access Servers*
- *SPE and Firmware Download Enhancements*
- *V.44 LZJH Compression for Cisco AS5300 and Cisco AS5800 Universal Access Servers*
- *V.92 Quick Connect for Cisco AS5300 and Cisco AS5800 Universal Access Servers*

Supported Platforms

- Cisco AS5300
- Cisco AS5800

Table 4 Cisco IOS Release and Platform Support for this Feature

Platform	12.2(2)XA	12.2(2)XB	12.2XB1	12.2(11)T
Cisco AS5300	X	X	X	X
Cisco AS5800	Not supported	Not supported	X	X

Determining Platform Support Through Cisco Feature Navigator

Cisco IOS software is packaged in feature sets that support specific platforms. To get updated information regarding platform support for this feature, access Cisco Feature Navigator. Cisco Feature Navigator dynamically updates the list of supported platforms as new platform support is added for the feature.

Cisco Feature Navigator is a web-based tool that enables you to determine which Cisco IOS software images support a specific set of features and which features are supported in a specific Cisco IOS image. You can search by feature or release. Under the release section, you can compare releases side by side to display both the features unique to each software release and the features in common.

To access Cisco Feature Navigator, you must have an account on Cisco.com. If you have forgotten or lost your account information, send a blank e-mail to cco-locksmith@cisco.com. An automatic check will verify that your e-mail address is registered with Cisco.com. If the check is successful, account details with a new random password will be e-mailed to you. Qualified users can establish an account on Cisco.com by following the directions at <https://tools.cisco.com/RPF/register/register.do>

Cisco Feature Navigator is updated regularly when major Cisco IOS software releases and technology releases occur. For the most current information, go to the Cisco Feature Navigator home page at the following URL:

<http://www.cisco.com/go/fn>

Availability of Cisco IOS Software Images

Platform support for particular Cisco IOS software releases is dependent on the availability of the software images for those platforms. Software images for some platforms may be deferred, delayed, or changed without prior notice. For updated information about platform support and availability of software images for each Cisco IOS software release, refer to the online release notes or, if supported, Cisco Feature Navigator.

Supported Standards, MIBs, and RFCs

Standards

- V.44
- V.92 Modem on Hold
- V.92 Quick Connect

MIBs

- CISCO-MODEM-MGMT-MIB
- CISCO-CALL-TRACKER-MODEM-MIB

To locate and download MIBs for selected platforms, Cisco IOS releases, and feature sets, use Cisco MIB Locator found at the following URL:

<http://tools.cisco.com/ITDIT/MIBS/servlet/index>

If Cisco MIB Locator does not support the MIB information that you need, you can also obtain a list of supported MIBs and download MIBs from the Cisco MIBs page at the following URL:

<http://www.cisco.com/public/sw-center/netmgmt/cmtk/mibs.shtml>

To access Cisco MIB Locator, you must have an account on Cisco.com. If you have forgotten or lost your account information, send a blank e-mail to cco-locksmith@cisco.com. An automatic check will verify that your e-mail address is registered with Cisco.com. If the check is successful, account details with a new random password will be e-mailed to you. Qualified users can establish an account on Cisco.com by following the directions found at this URL:

<http://www.cisco.com/register>

RFCs

No new or changed RFCs are supported by this feature.

Prerequisites

- Cisco IOS Release 12.2(2)XA, 12.2(2)XB, or 12.2(11)T
- V.92 MOH Portware DSP program memory required (in 16-bit words): 500
- Less than 50k bytes needed for CP memory
- Basic configuration of the Cisco AS5300 or Cisco AS5800 universal access server
- Upgraded modem firmware (Cisco MICA portware 2.9.1.0)
- Modems must be capable of supporting Modem on Hold

Configuration Tasks

None

Monitoring and Maintaining Modem on Hold

Use the following **show** commands in privileged EXEC mode.

Command	Purpose
Router# show modem configuration	Displays the current modem configuration for digital Cisco MICA technologies modems.
Router# show modem log	Displays the event log with oldest event first.
Router# show modem operational-status	Displays the operational status of the specified ports or the specified port range.

Configuration Examples

None

Command Reference

The following commands are introduced or modified in the feature or features documented in this module. For information about these commands, see the *Cisco IOS Dial Technologies Command Reference* at http://www.cisco.com/en/US/docs/ios/dial/command/reference/dia_book.html. For information about all Cisco IOS commands, go to the Command Lookup Tool at <http://tools.cisco.com/Support/CLILookup> or to the *Cisco IOS Master Commands List*.

- **show modem configuration**
- **show modem log**
- **show modem operational-status**

Glossary

CLI—command-line interface.

CSMv6—Mindspeed modem hardware solution.

CSR—call success rate.

DFC—dial feature card.

DSP—Digital Signal Processor. Microprocessor on which the modulation/demodulation process is carried out.

ISP—Internet service provider.

ITU-T—International Telecommunication Union Telecommunication Standardization Sector.

LZJH—Lempel-Ziv-Jeff-Heath data compression algorithm used in V.44.

MICA—Modem ISDN channel aggregation. Used as a generic term to describe the Dial Technology Division (DTD) high-density modem technology.

MOH—Modem on Hold functionality specified in V.92.

NextPort—Device driver architecture for Cisco IOS software that supports the NextPort hardware and software interfaces. Supports the Universal Port concept.

PCM—pulse code modulation.

PSTN—Public Switched Telephone Network.

RADIUS—Remote Dial-In User Service. Database for authenticating modem and ISDN connections and for tracking connection time.

SPE—service processing element.

universal port—Concept of a single device that can terminate one digital signaling level zero (DS0) with a data modem, fax modem, ISDN, or voice solution.

QC—Quick Connect functionality specified in V.92.

V.44—ITU modem standard for LZJH data compression algorithm.

V.92—ITU modem standard that contains Quick Connect, Modem On Hold, and PCM upstream.

VSA—vendor-specific attribute (as used with RADIUS).

Cisco and the Cisco logo are trademarks or registered trademarks of Cisco and/or its affiliates in the U.S. and other countries. To view a list of Cisco trademarks, go to this URL: www.cisco.com/go/trademarks. Third-party trademarks mentioned are the property of their respective owners. The use of the word partner does not imply a partnership relationship between Cisco and any other company. (1110R)

Any Internet Protocol (IP) addresses and phone numbers used in this document are not intended to be actual addresses and phone numbers. Any examples, command display output, network topology diagrams, and other figures included in the document are shown for illustrative purposes only. Any use of actual IP addresses or phone numbers in illustrative content is unintentional and coincidental.

© 2001-2009 Cisco Systems, Inc. All rights reserved.

