



BGP Configuration Guide for Cisco NCS 5500 Series Routers, IOS XR Release 7.2.x

First Published: 2020-08-01

Americas Headquarters

Cisco Systems, Inc.
170 West Tasman Drive
San Jose, CA 95134-1706
USA
<http://www.cisco.com>
Tel: 408 526-4000
800 553-NETS (6387)
Fax: 408 527-0883

THE SPECIFICATIONS AND INFORMATION REGARDING THE PRODUCTS IN THIS MANUAL ARE SUBJECT TO CHANGE WITHOUT NOTICE. ALL STATEMENTS, INFORMATION, AND RECOMMENDATIONS IN THIS MANUAL ARE BELIEVED TO BE ACCURATE BUT ARE PRESENTED WITHOUT WARRANTY OF ANY KIND, EXPRESS OR IMPLIED. USERS MUST TAKE FULL RESPONSIBILITY FOR THEIR APPLICATION OF ANY PRODUCTS.

THE SOFTWARE LICENSE AND LIMITED WARRANTY FOR THE ACCOMPANYING PRODUCT ARE SET FORTH IN THE INFORMATION PACKET THAT SHIPPED WITH THE PRODUCT AND ARE INCORPORATED HEREIN BY THIS REFERENCE. IF YOU ARE UNABLE TO LOCATE THE SOFTWARE LICENSE OR LIMITED WARRANTY, CONTACT YOUR CISCO REPRESENTATIVE FOR A COPY.

The Cisco implementation of TCP header compression is an adaptation of a program developed by the University of California, Berkeley (UCB) as part of UCB's public domain version of the UNIX operating system. All rights reserved. Copyright © 1981, Regents of the University of California.

NOTWITHSTANDING ANY OTHER WARRANTY HEREIN, ALL DOCUMENT FILES AND SOFTWARE OF THESE SUPPLIERS ARE PROVIDED "AS IS" WITH ALL FAULTS. CISCO AND THE ABOVE-NAMED SUPPLIERS DISCLAIM ALL WARRANTIES, EXPRESSED OR IMPLIED, INCLUDING, WITHOUT LIMITATION, THOSE OF MERCHANTABILITY, FITNESS FOR A PARTICULAR PURPOSE AND NON-INFRINGEMENT OR ARISING FROM A COURSE OF DEALING, USAGE, OR TRADE PRACTICE.

IN NO EVENT SHALL CISCO OR ITS SUPPLIERS BE LIABLE FOR ANY INDIRECT, SPECIAL, CONSEQUENTIAL, OR INCIDENTAL DAMAGES, INCLUDING, WITHOUT LIMITATION, LOST PROFITS OR LOSS OR DAMAGE TO DATA ARISING OUT OF THE USE OR INABILITY TO USE THIS MANUAL, EVEN IF CISCO OR ITS SUPPLIERS HAVE BEEN ADVISED OF THE POSSIBILITY OF SUCH DAMAGES.

Any Internet Protocol (IP) addresses and phone numbers used in this document are not intended to be actual addresses and phone numbers. Any examples, command display output, network topology diagrams, and other figures included in the document are shown for illustrative purposes only. Any use of actual IP addresses or phone numbers in illustrative content is unintentional and coincidental.

All printed copies and duplicate soft copies of this document are considered uncontrolled. See the current online version for the latest version.

Cisco has more than 200 offices worldwide. Addresses and phone numbers are listed on the Cisco website at www.cisco.com/go/offices.

Cisco and the Cisco logo are trademarks or registered trademarks of Cisco and/or its affiliates in the U.S. and other countries. To view a list of Cisco trademarks, go to this URL: <https://www.cisco.com/c/en/us/about/legal/trademarks.html>. Third-party trademarks mentioned are the property of their respective owners. The use of the word partner does not imply a partnership relationship between Cisco and any other company. (1721R)

© 2020 Cisco Systems, Inc. All rights reserved.



CONTENTS

PREFACE

Preface ix

Changes to This Document **ix**

Communications, Services, and Additional Information **ix**

CHAPTER 1

New and Changed BGP Features 1

New and Changed BGP Features **1**

CHAPTER 2

Implementing BGP 3

Information about Implementing BGP **3**

BGP Router Identifier **3**

BGP Default Limits **4**

BGP Attributes and Operators **5**

BGP Best Path Algorithm **15**

Comparing Pairs of Paths **15**

Order of Comparisons **17**

Best Path Change Suppression **18**

BGP Update Generation and Update Groups **18**

BGP Update Group **19**

BGP Cost Community Reference **19**

BGP Next Hop Reference **19**

BGP Nonstop Routing Reference **22**

BGP Route Reflectors Reference **23**

BGP Persistence **24**

iBGP Multipath Load Sharing Reference **25**

L3VPN iBGP PE-CE Reference **26**

MPLS VPN Carrier Supporting Carrier **26**

Per VRF and Per CE Label for IPv6 Provider Edge	27
IPv6 Unicast Routing	27
Remove and Replace Private AS Numbers from AS Path in BGP	27
BGP Update Message Error Handling	28
BGP Error Handling and Attribute Filtering Syslog Messages	29
BGP-RIB Feedback Mechanism for Update Generation	29
Use-defined Martian Check	30
BGP DMZ Aggregate Bandwidth	30
BGP Extended Route Retention	32
BGP Functional Overview	34
Enable BGP Routing	35
Adjust BGP Timers	39
Change BGP Default Local Preference Value	40
Configure MED Metric for BGP	41
Configure BGP Weights	42
Tune BGP Best-Path Calculation	44
Set BGP Administrative Distance	46
Indicate BGP Back-door Routes	47
Configure Aggregate Addresses	49
Understanding BGP MD5 Authentication	51
Configuring BGP MD5 Authentication	51
Hiding the Local AS Number for BGP Networks	52
Configuring BGP to Hide the Local AS Number	52
Autonomous System Number Formats in BGP	53
2-byte Autonomous System Number Format	53
4-byte Autonomous System Number Format	53
as-format Command	54
BGP Multi-Instance and Multi-AS	54
BGP Routing Domain Confederation	56
Configure Routing Domain Confederation for BGP	56
BGP Additional Paths	59
Configure BGP Additional Paths	59
128-Multipath ECMP	61
BGP Maximum Prefix	65

Configure Discard Extra Paths	66
BGP Best-External Path	68
Configure Best-External Path Advertisement	69
BGP Local Label Retention	70
Retain Allocated Local Label for Primary Path	70
iBGP Multipath Load Sharing	72
Configure iBGP Multipath Load Sharing	72
Route Dampening	73
Configuring BGP Route Dampening	74
Routing Policy Enforcement	75
Apply Policy When Updating Routing Table	75
Remotely Triggered Null Route Filtering with RPL Next-hop Discard Configuration	77
Configuring Destination-based RTBH Filtering	78
Verification	79
Configure BGP Neighbor Group and Neighbors	80
Disable BGP Neighbor	84
Resetting Neighbors Using BGP Inbound Soft Reset	85
Resetting Neighbors Using BGP Outbound Soft Reset	85
Reset Neighbors Using BGP Hard Reset	86
Configure Software to Store Updates from Neighbor	87
Log Neighbor Changes	89
BGP Route Reflectors	89
Configure Route Reflector for BGP	89
Configure BGP Route Filtering by Route Policy	91
Configure BGP Attribute Filtering	93
BGP Next Hop Tracking	94
Configure BGP Next-Hop Trigger Delay	94
Disable Next-Hop Processing on BGP Updates	96
BGP Cost Community	97
Configure BGP Cost Community	97
Configure BGP Community and Extended-Community Advertisements	100
Redistribute iBGP Routes into IGP	102
Redistribute IGP to BGP	103
Update Groups	105

Monitor BGP Update Groups	105
L3VPN iBGP PE-CE	106
Restrictions for L3VPN iBGP PE-CE	106
Configuring L3VPN iBGP PE-CE	107
Flow-tag propagation	109
Restrictions for Flow-Tag Propagation	110
Source and destination-based flow tag	110
BGP Keychains	112
Configure Keychains for BGP	112
Master Key Tuple Configuration	113
BGP Session Authentication and Integrity using TCP Authentication Option Overview	117
Master Key Tuples	117
Configure BGP Session Authentication and Integrity using TCP Authentication Option	117
BGP Nonstop Routing	119
Configure BGP Nonstop Routing	119
Disable BGP Nonstop Routing	120
Re-enable BGP Nonstop Routing	121
Resilient Hashing and Flow Auto-Recovery	122
Persistent Loadbalancing	123
Accumulated Interior Gateway Protocol Attribute	125
Originate Prefixes with AiGP	125
Configure BGP Accept Own	127
BGP Link-State	131
Configure BGP Link-state	135
Configure Domain Distinguisher	137
BGP Permanent Network	138
Configure BGP Permanent Network	139
Advertise Permanent Network	141
Enable BGP Unequal Cost Recursive Load Balancing	142
DMZ Link Bandwidth for Unequal Cost Recursive Load Balancing	146
DMZ Link Bandwidth Over EBGp Peer	150
BGP Prefix Origin Validation using RPKI	153
Configure RPKI Cache-server	153
Configure BGP Prefix Validation	156

Configure RPKI Bestpath Computation	158
Resilient Per-CE Label Allocation Mode	159
Configure Resilient Per-CE Label Allocation Mode Under VRF Address Family	159
Configure Resilient Per-CE Label Allocation Mode Using Route-Policy	161
BGP VRF Dynamic Route Leaking	163
Configure VRF Dynamic Route Leaking	163
Configuring a VPN Routing and Forwarding Instance in BGP	165
Define Virtual Routing and Forwarding Tables in Provider Edge Routers	166
Configure Route Distinguisher	167
Configure PE-PE or PE-RR Interior BGP Sessions	169
Configure BGP as PE-CE Protocol	172
Resetting an eBGP Session Immediately Upon Link Failure	176
Selective FIB Download	176
Configuring Selective FIB Download	178
Configuring BGP Large Communities	180
Multiprotocol BGP	184
Redistributing Prefixes into Multiprotocol BGP	186
BGP Monitoring Protocol	188
BGP Flowspec Overview	189
Flow Specifications	190
Supported Hardware	191
Supported Matching Criteria and Actions	191
Traffic Filtering Actions	194
BGP Flowspec Client-Server ControllerModel and Configuration	196
Configure BGP Flowspec	196
Flow Specifications	203
BGP Policy Accounting	203
BGP Flowspec Overview	205
Flow Specifications	205
Supported Hardware	206
Supported Matching Criteria and Actions	206
Traffic Filtering Actions	210
BGP Flowspec Client-Server ControllerModel and Configuration	211
Configure BGP Flowspec	212

CHAPTER 3 **BGP Dynamic Neighbors** **225**

 Configuring BGP Dynamic Neighbors using Address Range **225**

 Configuring BGP Dynamic Neighbors Using Address Range With Authentication **226**

 Maximum-peers and Idle-watch timeout **227**

CHAPTER 4 **EVPN Virtual Private Wire Service (VPWS)** **229**

 Information About EVPN-VPWS Single Homed **229**

 Configuring L2VPN EVPN Address Family Under BGP **230**

 Configuring EVPN-VPWS **231**

 Configuring EVPN-VPWS: Example **233**

CHAPTER 5 **BGP-based VPWS Autodiscovery** **235**

 Configuring VPWS with BGP Autodiscovery and Signaling **235**

 VPWS with BGP Autodiscovery and BGP Signaling **238**

CHAPTER 6 **Implementing Master Key Tuple Configuration** **245**

 Master Key Tuple Configuration **245**

 Keychain Configurations **246**

 Configuration Guidelines **246**

 Configuration Guidelines for TCP AO BGP Neighbor **246**

 Keychain Configuration **247**

 TCP Configuration **247**

 BGP Configurations **247**

 XML Configurations **248**

 Verification **248**

CHAPTER 7 **BGP Prefix Independent Convergence** **253**

 Convergence for BGP Labeled Unicast PIC Edge **254**

 BGP PIC Implementation Considerations **257**

 Configure BGP PIC **257**

 Configure BGP PIC Multipath **258**



Preface



Note This product has reached end-of-life status. For more information, see the [End-of-Life and End-of-Sale Notices](#).

The *Routing Configuration Guide for Cisco NCS 5500 Series Routers* preface contains these sections:

- [Changes to This Document, on page ix](#)
- [Communications, Services, and Additional Information, on page ix](#)

Changes to This Document

This table lists the technical changes made to this document since it was first released.

Table 1: Changes to This Document

Date	Summary
August 2020	Initial release of this document.

Communications, Services, and Additional Information

- To receive timely, relevant information from Cisco, sign up at [Cisco Profile Manager](#).
- To get the business impact you're looking for with the technologies that matter, visit [Cisco Services](#).
- To submit a service request, visit [Cisco Support](#).
- To discover and browse secure, validated enterprise-class apps, products, solutions and services, visit [Cisco Marketplace](#).
- To obtain general networking, training, and certification titles, visit [Cisco Press](#).
- To find warranty information for a specific product or product family, access [Cisco Warranty Finder](#).

Cisco Bug Search Tool

[Cisco Bug Search Tool](#) (BST) is a web-based tool that acts as a gateway to the Cisco bug tracking system that maintains a comprehensive list of defects and vulnerabilities in Cisco products and software. BST provides you with detailed defect information about your products and software.



CHAPTER 1

New and Changed BGP Features

This table summarizes the new and changed feature information for the *Routing Configuration Guide for Cisco NCS 5500 Series Routers*, and tells you where they are documented.

- [New and Changed BGP Features, on page 1](#)

New and Changed BGP Features

This table summarizes the new and changed feature information for the *Routing Configuration Guide for Cisco NCS 5500 Series Routers*, and tells you where they are documented.

Table 2: BGP Features Added or Modified in IOS XR Release 7.2.x

Feature	Description	Changed in Release	Where Documented
None	No new features introduced	Not applicable	Not applicable



CHAPTER 2

Implementing BGP

Border Gateway Protocol (BGP) is an Exterior Gateway Protocol (EGP) that allows you to create loop-free interdomain routing between autonomous systems. An *autonomous system* is a set of routers under a single technical administration. Routers in an autonomous system can use multiple Interior Gateway Protocols (IGPs) to exchange routing information inside the autonomous system and an EGP to route packets outside the autonomous system.

This module provides conceptual and configuration information on BGP.

Release	Modification
Release 6.0	This feature was introduced.

- [Information about Implementing BGP, on page 3](#)
- [BGP Functional Overview, on page 34](#)
- [Multiprotocol BGP, on page 184](#)
- [BGP Monitoring Protocol, on page 188](#)
- [BGP Flowspec Overview, on page 189](#)
- [Flow Specifications, on page 203](#)
- [BGP Policy Accounting, on page 203](#)
- [BGP Flowspec Overview, on page 205](#)

Information about Implementing BGP

To implement BGP, you need to understand the following concepts:

BGP Router Identifier

For BGP sessions between neighbors to be established, BGP must be assigned a router ID. The router ID is sent to BGP peers in the OPEN message when a BGP session is established.

BGP attempts to obtain a router ID in the following ways (in order of preference):

- By means of the address configured using the **bgp router-id** command in router configuration mode.
- By using the highest IPv4 address on a loopback interface in the system if the router is booted with saved loopback address configuration.

- By using the primary IPv4 address of the first loopback address that gets configured if there are not any in the saved configuration.

If none of these methods for obtaining a router ID succeeds, BGP does not have a router ID and cannot establish any peering sessions with BGP neighbors. In such an instance, an error message is entered in the system log, and the **show bgp summary** command displays a router ID of 0.0.0.0. After BGP has obtained a router ID, it continues to use it even if a better router ID becomes available. This usage avoids unnecessary flapping for all BGP sessions. However, if the router ID currently in use becomes invalid (because the interface goes down or its configuration is changed), BGP selects a new router ID (using the rules described) and all established peering sessions are reset.



Note We strongly recommend that the **bgp router-id** command is configured to prevent unnecessary changes to the router ID (and consequent flapping of BGP sessions).

BGP Default Limits

BGP imposes maximum limits on the number of neighbors that can be configured on the router and on the maximum number of prefixes that are accepted from a peer for a given address family. This limitation safeguards the router from resource depletion caused by misconfiguration, either locally or on the remote neighbor. The following limits apply to BGP configurations:

- The default maximum number of peers that can be configured is 4000. The default can be changed using the **bgp maximum neighbor** command. The *limit* range is 1–15000. Any attempt to configure additional peers beyond the maximum limit or set the maximum limit to a number that is less than the number of peers that are currently configured will fail.
- To prevent a peer from flooding BGP with advertisements, a limit is placed on the number of prefixes that are accepted from a peer for each supported address family. The default limits can be overridden through configuration of the maximum-prefix *limit* command for the peer for the appropriate address family. The following default limits are used if the user does not configure the maximum number of prefixes for the address family:
 - 512K (524,288) prefixes for IPv4 unicast
 - 128K (131,072) prefixes for IPv6 unicast
 - 512K (524,288) prefixes for VPNv4 unicast

A cease notification message is sent to the neighbor and the peering with the neighbor is terminated when the number of prefixes that are received from the peer for a given address family exceeds the maximum limit (either set by default or configured by the user) for that address family.

It is possible that the maximum number of prefixes for a neighbor for a given address family has been configured after the peering with the neighbor has been established and some prefixes have already been received from the neighbor for that address family. A cease notification message is sent to the neighbor and peering with the neighbor is terminated immediately after the configuration if the configured maximum number of prefixes is fewer than the number of prefixes that have already been received from the neighbor for the address family.

BGP Attributes and Operators

This table summarizes the BGP attributes and operators per attach points.

Table 3: BGP Attributes and Operators

Attach Point	Attribute	Match	Set
aggregation	as-path	in is-local length neighbor-is originates-from passes-through unique-length	—
	as-path-length	is, ge, le, eq	—
	as-path-unique-length	is, ge, le, eq	—
	community	is-empty matches-any matches-every	set set additive delete in delete not in delete all
	destination	in	—
	extcommunity cost	—	set set additive
	local-preference	is, ge, le, eq	set
	med	is, eg, ge, le	setset +set -
	next-hop	in	set
	origin	is	set
	source	in	—
	suppress-route	—	suppress-route
	weight	—	set

Attach Point	Attribute	Match	Set
allocate-label	as-path	in is-local length neighbor-is originates-from passes-through unique-length	—
	as-path-length	is, ge, le, eq	—
	as-path-unique-length	is, ge, le, eq	—
	community	is-empty matches-any matches-every	—
	destination	in	—
	label	—	set
	local-preference	is, ge, le, eq	—
	med	is, eg, ge, le	—
	next-hop	in	—
	origin	is	—
source	in	—	
clear-policy	as-path	in is-local length neighbor-is originates-from passes-through unique-length	—
	as-path-length	is, ge, le, eq	—
	as-path-unique-length	is, ge, le, eq	—

Attach Point	Attribute	Match	Set
dampening	as-path	in is-local length neighbor-is originates-from passes-through unique-length	—
	as-path-length	is, ge, le, eq	—
	as-path-unique-length	is, ge, le, eq	—
	community	is-empty matches-any matches-every	—
	dampening	—/	set dampening
	destination	in	—
	local-preference	is, ge, le, eq	—
	med	is, eg, ge, le	—
	next-hop	in	—
	origin	is	—
source	in	—	
debug	destination	in	—
default originate	med	—	set set + set -
	rib-has-route	in	—

Attach Point	Attribute	Match	Set
neighbor-in	as-path	in is-local length NA neighbor-is originates-from passes-through unique-length	prepend prepend most-recent remove as-path private-as replace
	as-path-length	is, ge, le, eq	—
	as-path-unique-length	is, ge, le, eq	—
	communitycommunity with 'peeras'	is-empty matches-any matches-every	set set additive delete-in delete-not-in delete-all
	destination	in	—
	extcommunity cost	—	set set additive
	extcommunity rt	is-empty matches-any matches-every matches-within	set additive delete-in delete-not-in delete-all
	extcommunity soo	is-empty matches-any matches-every matches-within	—
	local-preference	is, ge, le, eq	set
	med	is, eg, ge, le	set set + set -

Attach Point	Attribute	Match	Set
	next-hop	in	set set peer address
	origin	is	set
	route-aggregated	route-aggregated	NA
	source	in	—
	weight	—	set

Attach Point	Attribute	Match	Set
neighbor-out	as-path	in is-local length — neighbor-is originates-from passes-through unique-length	prepend prepend most-recent remove as-path private-as replace
	as-path-length	is, ge, le, eq	—
	as-path-unique-length	is, ge, le, eq	—
	communitycommunity with 'peeras'	is-empty matches-any matches-every	set set additive delete-in delete-not-in delete-all
	destination	in	—
	extcommunity cost	—	set set additive
	extcommunity rt	is-empty matches-any matches-every matches-within	set additive delete-in delete-not-in delete-all
	extcommunity soo	is-empty matches-any matches-every matches-within	—
	local-preference	is, ge, le, eq	set
med	is, eg, ge, le		

Attach Point	Attribute	Match	Set
			set set + set - set max-unreachable set igp-cost
	next-hop	in	set set self
	origin	is	set
	path-type	is	—
	rd	in	—
	route-aggregated	route-aggregated	—
	source	in	—
	unsuppress-route	—	unsuppress-route
	vpn-distinguisher	—	set
neighbor-orf	orf-prefix	in	n/a

Attach Point	Attribute	Match	Set
network	as-path	—	prepend
	community	—	set set additive delete-in delete-not-in delete-all
	destination	in	—
	extcommunity cost	—	set set additive
	mpls-label	route-has-label	—
	local-preference	—	set
	med	—	set set+ set-
	next-hop	in	set
	origin	—	set
	route-type	is	—
	tag	is, ge, le, eq	—
	weight	—	set
	next-hop	destination	in
protocol		is,in	—
source		in	—

Attach Point	Attribute	Match	Set
redistribute	as-path	—	prepend
	community	—	set set additive delete in delete not in delete all
	destination	in	—
	extcommunity cost	—	setset additive
	local-preference	—	set
	med	—	set set+ set-
	next-hop	in	set
	origin	—	set
	mpls-label	route-has-label	—
	route-type	is	—
	tag	is, eq, ge, le	—
	weight	—	set
retain-rt	extcommunity rt	is-empty matches-any matches-every matches-within	—

Attach Point	Attribute	Match	Set
show	as-path	in is-local length neighbor-is originates-from passes-through unique-length	—
	as-path-length	is, ge, le, eq	—
	as-path-unique-length	is, ge, le, eq	—
	community	is-empty matches-any matches-every	—
	destination	in	—
	extcommunity rt	is-empty matches-any matches-every matches-within	—
	extcommunity soo	is-empty matches-any matches-every matches-within	—
	med	is, eg, ge, le	—
	next-hop	in	—
	origin	is	—
source	in	—	

Some BGP route attributes are inaccessible from some BGP attach points for various reasons. For example, the **set med igp-cost only** command makes sense when there is a configured `igp-cost` to provide a source value.

This table summarizes which operations are valid and where they are valid.

Table 4: Restricted BGP Operations by Attach Point

Command	import	export	aggregation	redistribution
prepend as-path most-recent	eBGP only	eBGP only	n/a	n/a
replace as-path	eBGP only	eBGP only	n/a	n/a
set med igp-cost	forbidden	eBGP only	forbidden	forbidden
set weight	n/a	forbidden	n/a	n/a
suppress	forbidden	forbidden	n/a	forbidden

BGP Best Path Algorithm

BGP routers typically receive multiple paths to the same destination. The BGP best-path algorithm determines the best path to install in the IP routing table and to use for forwarding traffic. This section describes the Cisco IOS XR software implementation of BGP best-path algorithm, as specified in Section 9.1 of the Internet Engineering Task Force (IETF) Network Working Group draft-ietf-idr-bgp4-24.txt document.

The BGP best-path algorithm implementation is in three parts:

- Part 1—Compares two paths to determine which is better.
- Part 2—Iterates over all paths and determines which order to compare the paths to select the overall best path.
- Part 3—Determines whether the old and new best paths differ enough so that the new best path should be used.



Note The order of comparison determined by Part 2 is important because the comparison operation is not transitive; that is, if three paths, A, B, and C exist, such that when A and B are compared, A is better, and when B and C are compared, B is better, it is not necessarily the case that when A and C are compared, A is better. This nontransitivity arises because the multi exit discriminator (MED) is compared only among paths from the same neighboring autonomous system (AS) and not among all paths.

Comparing Pairs of Paths

Perform the following steps to compare two paths and determine the better path:

1. If either path is invalid (for example, a path has the maximum possible MED value or it has an unreachable next hop), then the other path is chosen (provided that the path is valid).
2. If the paths have unequal pre-bestpath cost communities, the path with the lower pre-bestpath cost community is selected as the best path.

3. If the paths have unequal weights, the path with the highest weight is chosen.



Note The weight is entirely local to the router, and can be set with the **weight** command or using a routing policy.

4. If the paths have unequal local preferences, the path with the higher local preference is chosen.



Note If a local preference attribute was received with the path or was set by a routing policy, then that value is used in this comparison. Otherwise, the default local preference value of 100 is used. The default value can be changed using the **bgp default local-preference** command.

5. If one of the paths is a redistributed path, which results from a **redistribute** or **network** command, then it is chosen. Otherwise, if one of the paths is a locally generated aggregate, which results from an **aggregate-address** command, it is chosen.



Note Step 1 through Step 4 implement the “Path Selection with BGP” of RFC 1268.

6. If the paths have unequal AS path lengths, the path with the shorter AS path is chosen. This step is skipped if **bgp bestpath as-path ignore** command is configured.



Note When calculating the length of the AS path, confederation segments are ignored, and AS sets count as 1.



Note eIBGP specifies internal and external BGP multipath peers. eIBGP allows simultaneous use of internal and external paths.

7. If the paths have different origins, the path with the lower origin is selected. Interior Gateway Protocol (IGP) is considered lower than EGP, which is considered lower than INCOMPLETE.

8. If appropriate, the MED of the paths is compared. If they are unequal, the path with the lower MED is chosen.

A number of configuration options exist that affect whether or not this step is performed. In general, the MED is compared if both paths were received from neighbors in the same AS; otherwise the MED comparison is skipped. However, this behavior is modified by certain configuration options, and there are also some corner cases to consider.

If the **bgp bestpath med always** command is configured, then the MED comparison is always performed, regardless of neighbor AS in the paths. Otherwise, MED comparison depends on the AS paths of the two paths being compared, as follows:

- If a path has no AS path or the AS path starts with an AS_SET, then the path is considered to be internal, and the MED is compared with other internal paths.

- If the AS path starts with an AS_SEQUENCE, then the neighbor AS is the first AS number in the sequence, and the MED is compared with other paths that have the same neighbor AS.
- If the AS path contains only confederation segments or starts with confederation segments followed by an AS_SET, then the MED is not compared with any other path unless the **bgp bestpath med confed** command is configured. In that case, the path is considered internal and the MED is compared with other internal paths.
- If the AS path starts with confederation segments followed by an AS_SEQUENCE, then the neighbor AS is the first AS number in the AS_SEQUENCE, and the MED is compared with other paths that have the same neighbor AS.



Note If no MED attribute was received with the path, then the MED is considered to be 0 unless the **bgp bestpath med missing-as-worst** command is configured. In that case, if no MED attribute was received, the MED is considered to be the highest possible value.

9. If one path is received from an external peer and the other is received from an internal (or confederation) peer, the path from the external peer is chosen.
10. If the paths have different IGP metrics to their next hops, the path with the lower IGP metric is chosen.
11. If the paths have unequal IP cost communities, the path with the lower IP cost community is selected as the best path.
12. If all path parameters in Step 1 through Step 10 are the same, then the router IDs are compared. If the path was received with an originator attribute, then that is used as the router ID to compare; otherwise, the router ID of the neighbor from which the path was received is used. If the paths have different router IDs, the path with the lower router ID is chosen.



Note Where the originator is used as the router ID, it is possible to have two paths with the same router ID. It is also possible to have two BGP sessions with the same peer router, and therefore receive two paths with the same router ID.

13. If the paths have different cluster lengths, the path with the shorter cluster length is selected. If a path was not received with a cluster list attribute, it is considered to have a cluster length of 0.
14. Finally, the path received from the neighbor with the lower IP address is chosen. Locally generated paths (for example, redistributed paths) are considered to have a neighbor IP address of 0.

Order of Comparisons

The second part of the BGP best-path algorithm implementation determines the order in which the paths should be compared. The order of comparison is determined as follows:

1. The paths are partitioned into groups such that within each group the MED can be compared among all paths. The same rules as in [#unique_15](#) are used to determine whether MED can be compared between any two paths. Normally, this comparison results in one group for each neighbor AS. If the **bgp bestpath med always** command is configured, then there is just one group containing all the paths.

2. The best path in each group is determined. Determining the best path is achieved by iterating through all paths in the group and keeping track of the best one seen so far. Each path is compared with the best-so-far, and if it is better, it becomes the new best-so-far and is compared with the next path in the group.
3. A set of paths is formed containing the best path selected from each group in Step 2. The overall best path is selected from this set of paths, by iterating through them as in Step 2.

Best Path Change Suppression

The third part of the implementation is to determine whether the best-path change can be suppressed or not—whether the new best path should be used, or continue using the existing best path. The existing best path can continue to be used if the new one is identical to the point at which the best-path selection algorithm becomes arbitrary (if the router-id is the same). Continuing to use the existing best path can avoid churn in the network.



Note This suppression behavior does not comply with the IETF Networking Working Group draft-ietf-idr-bgp4-24.txt document, but is specified in the IETF Networking Working Group draft-ietf-idr-avoid-transition-00.txt document.

The suppression behavior can be turned off by configuring the **bgp bestpath compare-routerid** command. If this command is configured, the new best path is always preferred to the existing one.

Otherwise, the following steps are used to determine whether the best-path change can be suppressed:

1. If the existing best path is no longer valid, the change cannot be suppressed.
2. If either the existing or new best paths were received from internal (or confederation) peers or were locally generated (for example, by redistribution), then the change cannot be suppressed. That is, suppression is possible only if both paths were received from external peers.
3. If the paths were received from the same peer (the paths would have the same router-id), the change cannot be suppressed. The router ID is calculated using rules in [#unique_15](#).
4. If the paths have different weights, local preferences, origins, or IGP metrics to their next hops, then the change cannot be suppressed. Note that all these values are calculated using the rules in [#unique_15](#).
5. If the paths have different-length AS paths and the **bgp bestpath as-path ignore** command is not configured, then the change cannot be suppressed. Again, the AS path length is calculated using the rules in [#unique_15](#).
6. If the MED of the paths can be compared and the MEDs are different, then the change cannot be suppressed. The decision as to whether the MEDs can be compared is exactly the same as the rules in [#unique_15](#), as is the calculation of the MED value.
7. If all path parameters in Step 1 through Step 6 do not apply, the change can be suppressed.

BGP Update Generation and Update Groups

The BGP Update Groups feature separates BGP update generation from neighbor configuration. The BGP Update Groups feature introduces an algorithm that dynamically calculates BGP update group membership based on outbound routing policies. This feature does not require any configuration by the network operator. Update group-based message generation occurs automatically and independently.

BGP Update Group

When a change to the configuration occurs, the router automatically recalculates update group memberships and applies the changes.

For the best optimization of BGP update group generation, we recommend that the network operator keeps outbound routing policy the same for neighbors that have similar outbound policies. This feature contains commands for monitoring BGP update groups.

BGP Cost Community Reference

The cost community attribute is applied to internal routes by configuring the **set extcommunity cost** command in a route policy. The cost community set clause is configured with a cost community ID number (0–255) and cost community number (0–4294967295). The cost community number determines the preference for the path. The path with the lowest cost community number is preferred. Paths that are not specifically configured with the cost community number are assigned a default cost community number of 2147483647 (the midpoint between 0 and 4294967295) and evaluated by the best-path selection process accordingly. When two paths have been configured with the same cost community number, the path selection process prefers the path with the lowest cost community ID. The cost-extended community attribute is propagated to iBGP peers when extended community exchange is enabled.

The following commands include the **route-policy** keyword, which you can use to apply a route policy that is configured with the cost community set clause:

- **aggregate-address**
- **redistribute**
- **network**

BGP Next Hop Reference

Event notifications from the RIB are classified as critical and noncritical. Notifications for critical and noncritical events are sent in separate batches. BGP is notified when any of the following events occurs:

- Next hop becomes unreachable
- Next hop becomes reachable
- Fully recursed IGP metric to the next hop changes
- First hop IP address or first hop interface change
- Next hop becomes connected
- Next hop becomes unconnected
- Next hop becomes a local address
- Next hop becomes a nonlocal address



Note Reachability and recursed metric events trigger a best-path recalculation.

However, a noncritical event is sent along with the critical events if the noncritical event is pending and there is a request to read the critical events.

- Critical events are related to the reachability (reachable and unreachable), connectivity (connected and unconnected), and locality (local and nonlocal) of the next hops. Notifications for these events are not delayed.
- Noncritical events include only the IGP metric changes. These events are sent at an interval of 3 seconds. A metric change event is batched and sent 3 seconds after the last one was sent.

BGP is notified when any of the following events occurs:

- Next hop becomes unreachable
- Next hop becomes reachable
- Fully recursed IGP metric to the next hop changes
- First hop IP address or first hop interface change
- Next hop becomes connected
- Next hop becomes unconnected
- Next hop becomes a local address
- Next hop becomes a nonlocal address



Note Reachability and recursed metric events trigger a best-path recalculation.

The next-hop trigger delay for critical and noncritical events can be configured to specify a minimum batching interval for critical and noncritical events using the **nexthop trigger-delay** command. The trigger delay is address family dependent.

The BGP next-hop tracking feature allows you to specify that BGP routes are resolved using only next hops whose routes have the following characteristics:

- To avoid the aggregate routes, the prefix length must be greater than a specified value.
- The source protocol must be from a selected list, ensuring that BGP routes are not used to resolve next hops that could lead to oscillation.

This route policy filtering is possible because RIB identifies the source protocol of route that resolved a next hop as well as the mask length associated with the route. The **nexthop route-policy** command is used to specify the route-policy.

Next Hop as the IPv6 Address of Peering Interface

BGP can carry IPv6 prefixes over an IPv4 session. The next hop for the IPv6 prefixes can be set through a nexthop policy. In the event that the policy is not configured, the nexthops are set as the IPv6 address of the peering interface (IPv6 neighbor interface or IPv6 update source interface, if any one of the interfaces is configured).

If the nexthop policy is not configured and neither the IPv6 neighbor interface nor the IPv6 update source interface is configured, the next hop is the IPv4 mapped IPv6 address.

Scoped IPv4/VPNv4 Table Walk

To determine which address family to process, a next-hop notification is received by first de-referencing the gateway context associated with the next hop, then looking into the gateway context to determine which address families are using the gateway context. The IPv4 unicast and VPNv4 unicast address families share the same gateway context, because they are registered with the IPv4 unicast table in the RIB. As a result, both the global IPv4 unicast table and the VPNv4 table are processed when an IPv4 unicast next-hop notification is received from the RIB. A mask is maintained in the next hop, indicating if whether the next hop belongs to IPv4 unicast or VPNv4 unicast, or both. This scoped table walk localizes the processing in the appropriate address family table.

Reordered Address Family Processing

The software walks address family tables based on the numeric value of the address family. When a next-hop notification batch is received, the order of address family processing is reordered to the following order:

- IPv4 tunnel
- VPNv4 unicast
- VPNv6 unicast
- IPv4 labeled unicast
- IPv4 unicast
- IPv4 MDT
- IPv6 unicast
- IPv6 labeled unicast
- IPv4 tunnel
- VPNv4 unicast
- IPv4 unicast
- IPv6 unicast

New Thread for Next-Hop Processing

The critical-event thread in the spkr process handles only next-hop, Bidirectional Forwarding Detection (BFD), and fast-external-failover (FEF) notifications. This critical-event thread ensures that BGP convergence is not adversely impacted by other events that may take a significant amount of time.

show, clear, and debug Commands

The **show bgp nexthops** command provides statistical information about next-hop notifications, the amount of time spent in processing those notifications, and details about each next hop registered with the RIB. The **clear bgp nexthop performance-statistics** command ensures that the cumulative statistics associated with the processing part of the next-hop **show** command can be cleared to help in monitoring. The **clear bgp nexthop registration** command performs an asynchronous registration of the next hop with the RIB.

The **debug bgp nexthop** command displays information on next-hop processing. The **out** keyword provides debug information only about BGP registration of next hops with RIB. The **in** keyword displays debug information about next-hop notifications received from RIB. The **out** keyword displays debug information about next-hop notifications sent to the RIB.

BGP Nonstop Routing Reference

BGP NSR provides nonstop routing during the following events:

- Route processor switchover
- Process crash or process failure of BGP or TCP



Note BGP NSR is enabled by default. Use the **nsr disable** command to turn off BGP NSR. The **no nsr disable** command can also be used to turn BGP NSR back on if it has been disabled.

In case of process crash or process failure, NSR will be maintained only if **nsr process-failures switchover** command is configured. In the event of process failures of active instances, the **nsr process-failures switchover** configures failover as a recovery action and switches over to a standby route processor (RP) or a standby distributed route processor (DRP) thereby maintaining NSR. An example of the configuration command is `RP/0/RSP0/CPU0:router(config)# nsr process-failures switchover`

The **nsr process-failures switchover** command maintains both the NSR and BGP sessions in the event of a BGP or TCP process crash. Without this configuration, BGP neighbor sessions flap in case of a BGP or TCP process crash. This configuration does not help if the BGP or TCP process is restarted in which case the BGP neighbors are expected to flap.

When the `l2vpn_mgr` process is restarted, the NSR client (te-control) flaps between the **Ready** and **Not Ready** state. This is the expected behavior and there is no traffic loss.

During route processor switchover and In-Service System Upgrade (ISSU), NSR is achieved by stateful switchover (SSO) of both TCP and BGP.

NSR does not force any software upgrades on other routers in the network, and peer routers are not required to support NSR.

When a route processor switchover occurs due to a fault, the TCP connections and the BGP sessions are migrated transparently to the standby route processor, and the standby route processor becomes active. The existing protocol state is maintained on the standby route processor when it becomes active, and the protocol state does not need to be refreshed by peers.

Events such as soft reconfiguration and policy modifications can trigger the BGP internal state to change. To ensure state consistency between active and standby BGP processes during such events, the concept of post-it is introduced that act as synchronization points.

BGP NSR provides the following features:

- NSR-related alarms and notifications
- Configured and operational NSR states are tracked separately
- NSR statistics collection
- NSR statistics display using **show** commands

- XML schema support
- Auditing mechanisms to verify state synchronization between active and standby instances
- CLI commands to enable and disable NSR

BGP Route Reflectors Reference

[#unique_22_unique_22_Connect_42_fig_ED746D3CC16E445F85EB3B1CE06B3767](#) illustrates a simple iBGP configuration with three iBGP speakers (routers A, B, and C). Without route reflectors, when Router A receives a route from an external neighbor, it must advertise it to both routers B and C. Routers B and C do not readvertise the iBGP learned route to other iBGP speakers because the routers do not pass on routes learned from internal neighbors to other internal neighbors, thus preventing a routing information loop.

With route reflectors, all iBGP speakers need not be fully meshed because there is a method to pass learned routes to neighbors. In this model, an iBGP peer is configured to be a route reflector responsible for passing iBGP learned routes to a set of iBGP neighbors. In [#unique_22_unique_22_Connect_42_fig_3980C23832D84D43BB58222F040E5A96](#), Router B is configured as a route reflector. When the route reflector receives routes advertised from Router A, it advertises them to Router C, and vice versa. This scheme eliminates the need for the iBGP session between routers A and C.

The internal peers of the route reflector are divided into two groups: client peers and all other routers in the autonomous system (nonclient peers). A route reflector reflects routes between these two groups. The route reflector and its client peers form a *cluster*. The nonclient peers must be fully meshed with each other, but the client peers need not be fully meshed. The clients in the cluster do not communicate with iBGP speakers outside their cluster.

[#unique_22_unique_22_Connect_42_fig_9026266F2853489B94D037A781853752](#) illustrates a more complex route reflector scheme. Router A is the route reflector in a cluster with routers B, C, and D. Routers E, F, and G are fully meshed, nonclient routers.

When the route reflector receives an advertised route, depending on the neighbor, it takes the following actions:

- A route from an external BGP speaker is advertised to all clients and nonclient peers.
- A route from a nonclient peer is advertised to all clients.
- A route from a client is advertised to all clients and nonclient peers. Hence, the clients need not be fully meshed.

Along with route reflector-aware BGP speakers, it is possible to have BGP speakers that do not understand the concept of route reflectors. They can be members of either client or nonclient groups, allowing an easy and gradual migration from the old BGP model to the route reflector model. Initially, you could create a single cluster with a route reflector and a few clients. All other iBGP speakers could be nonclient peers to the route reflector and then more clusters could be created gradually.

An autonomous system can have multiple route reflectors. A route reflector treats other route reflectors just like other iBGP speakers. A route reflector can be configured to have other route reflectors in a client group or nonclient group. In a simple configuration, the backbone could be divided into many clusters. Each route reflector would be configured with other route reflectors as nonclient peers (thus, all route reflectors are fully meshed). The clients are configured to maintain iBGP sessions with only the route reflector in their cluster.

Usually, a cluster of clients has a single route reflector. In that case, the cluster is identified by the router ID of the route reflector. To increase redundancy and avoid a single point of failure, a cluster might have more than one route reflector. In this case, all route reflectors in the cluster must be configured with the cluster ID

so that a route reflector can recognize updates from route reflectors in the same cluster. All route reflectors serving a cluster should be fully meshed and all of them should have identical sets of client and nonclient peers.

By default, the clients of a route reflector are not required to be fully meshed and the routes from a client are reflected to other clients. However, if the clients are fully meshed, the route reflector need not reflect routes to clients.

As the iBGP learned routes are reflected, routing information may loop. The route reflector model has the following mechanisms to avoid routing loops:

- Originator ID is an optional, nontransitive BGP attribute. It is a 4-byte attribute created by a route reflector. The attribute carries the router ID of the originator of the route in the local autonomous system. Therefore, if a misconfiguration causes routing information to come back to the originator, the information is ignored.
- Cluster-list is an optional, nontransitive BGP attribute. It is a sequence of cluster IDs that the route has passed. When a route reflector reflects a route from its clients to nonclient peers, and vice versa, it appends the local cluster ID to the cluster-list. If the cluster-list is empty, a new cluster-list is created. Using this attribute, a route reflector can identify if routing information is looped back to the same cluster due to misconfiguration. If the local cluster ID is found in the cluster-list, the advertisement is ignored.

BGP Persistence

BGP persistence enables the local router to retain routes that it has learnt from the configured neighbor even after the neighbor session is down. BGP persistence is also referred as Long Lived Graceful Restart (LLGR). LLGR takes effect after graceful restart (GR) ends or immediately if GR is not enabled. LLGR ends either when the LLGR stale timer expires or when the neighbor sends the end-of-RIB marker after it has revised its routes. When LLGR for a neighbor ends, all routes from that neighbor that are still stale will be deleted. The LLGR capability is signaled to a neighbor in the BGP OPEN message if it has been configured for that neighbor.

LLGR differs from graceful restart in the following ways.

- It can be in effect for a much longer time than GR.
- LLGR stale routes are least preferred during route selection (bestpath computation).
- An LLGR stale route will be advertised with the LLGR_STALE community attached if it is selected as best path. It will not be advertised at all to routers that are not LLGR capable.
- LLGR stale routes will not be deleted when the forwarding path to the neighbor is detected to be down.
- An LLGR stale route will not be deleted if the BGP session to the neighbor goes down multiple times even if that neighbor does not re-advertise the route.
- Any route that has the NO_LLGR community will not be retained.

BGP will not pass the updates containing communities 65535:6, 65535:7 to its neighbors until the neighbors negotiate BGP persistence capabilities. The communities 65535:6 and 65535:7 are reserved for LLGR_STALE and NO_LLGR respectively, BGP behavior maybe unpredictable if you have configured these communities prior to release 5.2.2. We recommend not to configure the communities 65535:6 and 65535:7.

The BGP persistence feature is supported only on the following AFIs:

- VPNv4 and VPNv6

- RT constraint
- Flow spec (IPv4, IPv6, VPNv4 and VPNv6)
- Private IPv4 and IPv6 (IPv4/v6 address family inside VRF)

BGP Persistence Configuration: Example

This example sets long lived graceful restart (LLGR) stale-time of 16777215 on BGP neighbor 10.3.3.3.

```
router bgp 100
 neighbor 10.3.3.3
   remote-as 30813
   update-source Loopback0
   graceful-restart stalepath-time 150
   address-family vpnv4 unicast
     long-lived-graceful-restart capable
     long-lived-graceful-restart stale-time send 16777215 accept 16777215
   !
   address-family vpnv6 unicast
     long-lived-graceful-restart capable
     long-lived-graceful-restart stale-time send 16777215 accept 16777215
```

iBGP Multipath Load Sharing Reference

When there are multiple border BGP routers having reachability information heard over eBGP, if no local policy is applied, the border routers will choose their eBGP paths as best. They advertise that bestpath inside the ISP network. For a core router, there can be multiple paths to the same destination, but it will select only one path as best and use that path for forwarding. iBGP multipath load sharing adds the ability to enable load sharing among multiple equi-distant paths. Configuring multiple iBGP best paths enables a router to evenly share the traffic destined for a particular site. The iBGP Multipath Load Sharing feature functions similarly in a Multiprotocol Label Switching (MPLS) Virtual Private Network (VPN) with a service provider backbone.

For multiple paths to the same destination to be considered as multipaths, the following criteria must be met:

- All attributes must be the same. The attributes include weight, local preference, autonomous system path (entire attribute and not just length), origin code, Multi Exit Discriminator (MED), and Interior Gateway Protocol (iGP) distance.
- The next hop router for each multipath must be different.

Even if the criteria are met and multiple paths are considered multipaths, the BGP speaking router designates one of the multipaths as the best path and advertises this best path to its neighbors.



Note

- Overwriting of next-hop calculation for multipath prefixes is not allowed. The **next-hop-unchanged multipath** command disables overwriting of next-hop calculation for multipath prefixes.
- The ability to ignore as-path onwards while computing multipath is added. The **bgp multipath as-path ignore onwards** command ignores as-path onwards while computing multipath.

L3VPN iBGP PE-CE Reference

When BGP is used as the provider edge (PE) or the customer edge (CE) routing protocol, the peering sessions are configured as external peering between the VPN provider autonomous system (AS) and the customer network autonomous system. The L3VPN iBGP PE-CE feature enables the PE and CE devices to exchange Border Gateway Protocol (BGP) routing information by peering as internal Border Gateway Protocol (iBGP) instead of the widely-used external BGP peering between the PE and the CE. This mechanism applies at each PE device where a VRF-based CE is configured as iBGP. This eliminates the need for service providers (SPs) to configure autonomous system override for the CE. With this feature enabled, there is no need to configure the virtual private network (VPN) sites using different autonomous systems.

The **neighbor internal-vpn-client** command enables PE devices to make an entire VPN cloud act as an internal VPN client to the CE devices. These CE devices are connected internally to the VPN cloud through the iBGP PE-CE connection inside the VRF. After this connection is established, the PE device encapsulates the CE-learned path into an attribute called ATTR_SET and carries it in the iBGP-sourced path throughout the VPN core to the remote PE device. At the remote PE device, this attribute is assigned with individual attributes and the source CE path is extracted and sent to the remote CE devices.

ATTR_SET is an optional transitive attribute that carries the CE path attributes received. The ATTR_SET attribute is encoded inside the BGP update message as follows:

```
+-----+
| Attr Flags (O/T) Code = 128 |
+-----+
| Attr. Length (1 or 2 octets) |
+-----+
| Origin AS (4 octets) |
+-----+
| Path attributes (variable) |
+-----+
```

Origin AS is the AS of the VPN customer for which the ATTR_SET is generated. The minimum length of ATTR_SET is four bytes and the maximum is the maximum supported for a path attribute after taking into consideration the mandatory fields and attributes in the BGP update message. It is recommended that the maximum length is limited to 3500 bytes. ATTR_SET must not contain the following attributes: MP_REACH, MP_UNREACH, NEW_AS_PATH, NEW_AGGR, NEXT_HOP and ATTR_SET itself (ATTR_SET inside ATTR_SET). If these attributes are found inside the ATTR_SET, the ATTR_SET is considered invalid and the corresponding error handling mechanism is invoked.

MPLS VPN Carrier Supporting Carrier

Carrier supporting carrier (CSC) is a term used to describe a situation in which one service provider allows another service provider to use a segment of its backbone network. The service provider that provides the segment of the backbone network to the other provider is called the *backbone carrier*. The service provider that uses the segment of the backbone network is called the *customer carrier*.

A backbone carrier offers Border Gateway Protocol and Multiprotocol Label Switching (BGP/MPLS) VPN services. The customer carrier can be either:

- An Internet service provider (ISP) (By definition, an ISP does not provide VPN service.)
- A BGP/MPLS VPN service provider

You can configure a CSC network to enable BGP to transport routes and MPLS labels between the backbone carrier provider edge (PE) routers and the customer carrier customer edge (CE) routers using multiple paths. The benefits of using BGP to distribute IPv4 routes and MPLS label routes are:

- BGP takes the place of an Interior Gateway Protocol (IGP) and Label Distribution Protocol (LDP) in a VPN routing and forwarding (VRF) table. You can use BGP to distribute routes and MPLS labels. Using a single protocol instead of two simplifies the configuration and troubleshooting.
- BGP is the preferred routing protocol for connecting two ISPs, mainly because of its routing policies and ability to scale. ISPs commonly use BGP between two providers. This feature enables those ISPs to use BGP.

For detailed information on configuring MPLS VPN CSC with BGP, see the *Implementing MPLS Layer 3 VPNs on* module of the *MPLS Configuration Guide*.

Per VRF and Per CE Label for IPv6 Provider Edge

The per VRF and per CE label for IPv6 feature makes it possible to save label space by allocating labels per default VRF or per CE nexthop.

All IPv6 Provider Edge (6PE) labels are allocated per prefix by default. Each prefix that belongs to a VRF instance is advertised with a single label, causing an additional lookup to be performed in the VRF forwarding table to determine the customer edge (CE) next hop for the packet.

However, use the **label-allocation-mode** command with the **per-ce** keyword or the **per-vrf** keyword to avoid the additional lookup on the PE router and conserve label space.

Use **per-ce** keyword to specify that the same label be used for all the routes advertised from a unique customer edge (CE) peer router. Use the **per-vrf** keyword to specify that the same label be used for all the routes advertised from a unique VRF.

IPv6 Unicast Routing

Cisco provides complete Internet Protocol Version 6 (IPv6) unicast capability.

An IPv6 unicast address is an identifier for a single interface, on a single node. A packet that is sent to a unicast address is delivered to the interface identified by that address. Cisco IOS XR software supports the following IPv6 unicast address types:

- Global aggregatable address
- Site-local address
- Link-local address
- IPv4-compatible IPv6 address

For more information on IPv6 unicast addressing, refer the *IP Addresses and Services Configuration Guide*.

Remove and Replace Private AS Numbers from AS Path in BGP

Private autonomous system numbers (ASNs) are used by Internet Service Providers (ISPs) and customer networks to conserve globally unique AS numbers. Private AS numbers cannot be used to access the global Internet because they are not unique. AS numbers appear in eBGP AS paths in routing updates. Removing

private ASNs from the AS path is necessary if you have been using private ASNs and you want to access the global Internet.

Public AS numbers are assigned by InterNIC and are globally unique. They range from 1 to 64511. Private AS numbers are used to conserve globally unique AS numbers, and they range from 64512 to 65535. Private AS numbers cannot be leaked to a global BGP routing table because they are not unique, and BGP best path calculations require unique AS numbers. Therefore, it might be necessary to remove private AS numbers from an AS path before the routes are propagated to a BGP peer.

External BGP (eBGP) requires that globally unique AS numbers be used when routing to the global Internet. Using private AS numbers (which are not unique) would prevent access to the global Internet. The remove and replace private AS Numbers from AS Path in BGP feature allows routers that belong to a private AS to access the global Internet. A network administrator configures the routers to remove private AS numbers from the AS path contained in outgoing update messages and optionally, to replace those numbers with the ASN of the local router, so that the AS Path length remains unchanged.

The ability to remove and replace private AS numbers from the AS Path is implemented in the following ways:

- The **remove-private-as** command removes private AS numbers from the AS path even if the path contains both public and private ASNs.
- The **remove-private-as** command removes private AS numbers even if the AS path contains only private AS numbers. There is no likelihood of a 0-length AS path because this command can be applied to eBGP peers only, in which case the AS number of the local router is appended to the AS path.
- The **remove-private-as** command removes private AS numbers even if the private ASNs appear before the confederation segments in the AS path.
- The **replace-as** command replaces the private AS numbers being removed from the path with the local AS number, thereby retaining the same AS path length.

The feature can be applied to neighbors per address family (address family configuration mode). Therefore, you can apply the feature for a neighbor in one address family and not on another, affecting update messages on the outbound side for only the address family for which the feature is configured.

Use **show bgp neighbors** and **show bgp update-group** commands to verify that the private AS numbers were removed or replaced.

BGP Update Message Error Handling

The BGP UPDATE message error handling changes BGP behavior in handling error UPDATE messages to avoid session reset. Based on the approach described in IETF IDR *I-D:draft-ietf-idr-error-handling*, the Cisco IOS XR BGP UPDATE Message Error handling implementation classifies BGP update errors into various categories based on factors such as, severity, likelihood of occurrence of UPDATE errors, or type of attributes. Errors encountered in each category are handled according to the draft. Session reset will be avoided as much as possible during the error handling process. Error handling for some of the categories are controlled by configuration commands to enable or disable the default behavior.

According to the base BGP specification, a BGP speaker that receives an UPDATE message containing a malformed attribute is required to reset the session over which the offending attribute was received. This behavior is undesirable as a session reset would impact not only routes with the offending attribute, but also other valid routes exchanged over the session.

BGP Error Handling and Attribute Filtering Syslog Messages

When a router receives a malformed update packet, an `ios_msg` of type `ROUTING-BGP-3-MALFORM_UPDATE` is printed on the console. This is rate limited to 1 message per minute across all neighbors. For malformed packets that result in actions "Discard Attribute" (A5) or "Local Repair" (A6), the `ios_msg` is printed only once per neighbor per action. This is irrespective of the number of malformed updates received since the neighbor last reached an "Established" state.

This is a sample BGP error handling syslog message:

```
%ROUTING-BGP-3-MALFORM_UPDATE : Malformed UPDATE message received from neighbor 13.0.3.50
- message length 90 bytes,
  error flags 0x00000840, action taken "TreatAsWithdraw".
Error details: "Error 0x00000800, Field "Attr-missing", Attribute 1 (Flags 0x00, Length 0),
  Data []"
```

This is a sample BGP attribute filtering syslog message for the "discard attribute" action:

```
[4843.46]RP/0/0/CPU0:Aug 21 17:06:17.919 : bgp[1037]: %ROUTING-BGP-5-UPDATE_FILTERED :
One or more attributes were filtered from UPDATE message received from neighbor 40.0.101.1
- message length 173 bytes,
  action taken "DiscardAttr".
Filtering details: "Attribute 16 (Flags 0xc0): Action "DiscardAttr"". NLRIs: [IPv4 Unicast]
88.2.0.0/17
```

This is a sample BGP attribute filtering syslog message for the "treat-as-withdraw" action:

```
[391.01]RP/0/0/CPU0:Aug 20 19:41:29.243 : bgp[1037]: %ROUTING-BGP-5-UPDATE_FILTERED :
One or more attributes were filtered from UPDATE message received from neighbor 40.0.101.1
- message length 166 bytes,
  action taken "TreatAsWdr".
Filtering details: "Attribute 4 (Flags 0xc0): Action "TreatAsWdr"". NLRIs: [IPv4 Unicast]
88.2.0.0/17
```

BGP-RIB Feedback Mechanism for Update Generation

The Border Gateway Protocol-Routing Information Base (BGP-RIB) feedback mechanism for update generation feature avoids premature route advertisements and subsequent packet loss in a network. This mechanism ensures that routes are installed locally, before they are advertised to a neighbor.

BGP waits for feedback from RIB indicating that the routes that BGP installed in RIB are installed in forwarding information base (FIB) before BGP sends out updates to the neighbors. RIB uses the the BCDL feedback mechanism to determine which version of the routes have been consumed by FIB, and updates the BGP with that version. BGP will send out updates of only those routes that have versions up to the version that FIB has installed. This selective update ensures that BGP does not send out premature updates resulting in attracting traffic even before the data plane is programmed after router reload, LC OIR, or flap of a link where an alternate path is made available.

To configure BGP to wait for feedback from RIB indicating that the routes that BGP installed in RIB are installed in FIB, before BGP sends out updates to neighbors, use the **update wait-install** command in router address-family IPv4 or router address-family VPNv4 configuration mode. The **show bgp**, **show bgp neighbors**, and **show bgp process performance-statistics** commands display the information from update wait-install configuration.

Use-defined Martian Check

The solution allows disabling the Martian check for these IP address prefixes:

- IPv4 address prefixes
 - 0.0.0.0/8
 - 127.0.0.0/8
 - 224.0.0.0/4
- IPv6 address prefixes
 - ::
 - ::0002 - ::ffff
 - ::ffff:a.b.c.d
 - fe80:xxxx
 - ffxx:xxxx

BGP DMZ Aggregate Bandwidth

Table 5: Feature History Table

Feature Name	Release Information	Feature Description
Removal of Link-Bandwidth Extended Community to iBGP Peers	Release 7.3.2	The demilitarized zone (DMZ) link-bandwidth extended community allows BGP to send traffic over multiple internal BGP (iBGP) learned paths. The traffic that is sent is proportional to the bandwidth of the links that are used to exit the autonomous system. By default, iBGP propagates DMZ link-bandwidth community. The Removal of Link-Bandwidth Extended Community to iBGP Peers feature provides the flexibility to remove the DMZ link-bandwidth community to minimize the risk of exposure of the community parameters to networks zones where they are not recognized or unnecessary.

BGP supports aggregating *dmz-link bandwidth* values of external BGP (eBGP) multipaths when advertising the route to interior BGP (iBGP) peer.

There is no explicit command to aggregate bandwidth. The bandwidth is aggregated if following conditions are met:

- The network has multipaths and all the multipaths have link-bandwidth values.
- The next-hop attribute set to next-hop-self. The next-hop attribute for all routes advertised to the specified neighbor to the address of the local router.
- There is no out-bound policy configured that might change the dmz-link bandwidth value.

- If the *dmz-link bandwidth* value is not known for any one of the multipaths (eBGP or iBGP), the *dmz-link* value for all multipaths including the best path is not downloaded to routing information base (RIB).
- The *dmz-link bandwidth* value of iBGP multipath is not considered during aggregation.
- The route that is advertised with aggregate value can be best path or add-path.
- Add-path does not qualify for DMZ link bandwidth aggregation as next hop is preserved. Configuring next-hop-self for add-path is not supported.
- For VPNv4 and VPNv6 afi, if *dmz link-bandwidth* value is configured using outbound route-policy, specify the route table or use the **additive** keyword. Else, this will lead to routes not imported on the receiving end of the peer.

```

extcommunity-set bandwidth dmz_ext
  1:8000
end-set
!
route-policy dmz_rp_vpn
  set extcommunity bandwidth dmz_ext additive    <<< 'additive' keyword.
  pass
end-policy

```

Removal of Link-Bandwidth Extended Community to iBGP Peers

The demilitarized zone (DMZ) link-bandwidth extended community allows BGP to send traffic over multiple internal BGP (iBGP) learned paths. The traffic that is sent is proportional to the bandwidth of the links that are used to exit the autonomous system. By default, iBGP propagates DMZ link-bandwidth community. The Removal of Link-Bandwidth Extended Community to iBGP Peers feature provides the flexibility to remove the DMZ link-bandwidth community to minimize the risk of exposure of the community parameters to networks zones where they are not recognized or unnecessary.

Configuration Example

Perform the following steps to allow users to be able to configure route-policy to remove the extended communities.

```

/* Delete all the extended communities. */
Router(config)# route-policy dmz_del_all
Router(config-rpl)# delete extcommunity bandwidth all
Router(config-rpl)# pass
Router(config-rpl)# end-policy

/* Delete only the extended communities that match an extended community mentioned in the
list. */
Router(config)# route-policy dmz_CE1_del_non_match
Router(config-rpl)# if destination in (10.9.9.9/32) then
Router(config-rpl-if)# delete extcommunity bandwidth in (10:7000)
Router(config-rpl-if)# endif
Router(config-rpl)# pass
Router(config-rpl)# end-policy

/* Delete all the extended communities. */
Router(config)# route-policy dmz_del_param2($a,$b)
Router(config-rpl)# if destination in (10.9.9.9/32) then
Router(config-rpl-if)# delete extcommunity bandwidth in ($a:$b)
Router(config-rpl-if)# endif
Router(config-rpl)# pass
Router(config-rpl)# end-policy

```

Verification

Verify the configuration that allows the user to remove a particular extended community.

```

Router# show bgp 10.9.9.9/32
Fri Aug 27 13:15:05.833 EDT
BGP routing table entry for 10.9.9.9/32
Versions:
Process bRIB/RIB SendTblVer
Speaker 15 15
Last Modified: Aug 27 13:06:45.000 for 00:08:21
Paths: (3 available, best #1)
Advertised IPv4 Unicast paths to peers (in unique update groups):
13.13.13.5
Path #1: Received by speaker 0
Advertised IPv4 Unicast paths to peers (in unique update groups):
13.13.13.5
10
10.10.10.1 from 10.10.10.1 (192.168.0.1)
Origin incomplete, metric 0, localpref 100, valid, external, best, group-best, multipath
Received Path ID 0, Local Path ID 1, version 15
Extended community: LB:10:48
Origin-AS validity: (disabled)
Path #2: Received by speaker 0
Not advertised to any peer
10
11.11.11.3 from 11.11.11.3 (192.168.0.3)
Origin incomplete, metric 0, localpref 100, valid, external, multipath
Received Path ID 0, Local Path ID 0, version 0
Extended community: LB:10:48
Origin-AS validity: (disabled)
Path #3: Received by speaker 0
Not advertised to any peer
10
12.12.12.4 from 12.12.12.4 (192.168.0.4)
Origin incomplete, metric 0, localpref 100, valid, external, multipath
Received Path ID 0, Local Path ID 0, version 0
Extended community: LB:10:48
Origin-AS validity: (disabled)

22:35 30-09-2021

```

BGP Extended Route Retention

Table 6: Feature History Table

Feature Name	Release Name	Description
BGP Extended Route Retention	Release 7.3.3	This feature allows you to maintain stale routing information from a failed BGP peer for longer periods of time than that is configured in the Graceful Restart attribute. However, this feature ensures that the BGP neighbor considers the stale routes as new routes.

When a BGP peer fails, the BGP Extended Route Retention feature applies the route retention policy to the routes to modify the route attributes. This feature modifies the route attributes in addition to the modification

that occur due to neighbor's inbound policy. This feature enables the use of route retention policy in place of LLGR, when the BGP hold timer expires or when the BGP session fails to reestablish as a receiving speaker within the configured graceful restart timer.

When you apply LLGR, you cannot remove the LLGR_STALE community when the stale route is advertised, and the route will treat it as the least preferred. Also, stale routes may be advertised to those neighbors that would not have advertised the LLGR capability under the following conditions:

- The neighbors must be internal, either IBGP or confederation, neighbors.
- The NO_EXPORT community must be attached to the stale routes.
- The stale routes must have their LOCAL_PREF community set to zero.

This feature provides you the flexibility to advertise stale routes to eBGP neighbors and enable you to specify local preference values for any stale route that is retained within the iBGP system.

Restrictions

- The neighbor should be capable of graceful restart.
- When the BGP neighbor fails, the graceful restart functionality is applied till the graceful restart timer is valid.
- The Extend Route Retention feature starts, when the graceful restart timer expires,
- Soft-reconfiguration inbound configuration is a mandatory configuration. If required, configure the inbound policy.
- The Extended Route Retention feature starts only when BGP peer goes down, that is, on the expiry of the hold-down timer.
- For any other trigger, such as the expiry of a timer, the routes are not indicated as stale and the routes are purged.
- The Extended Route Retention feature is applicable only in the following address-family modes:
 - IPv4 and IPv6 unicast address family mode
 - IPv4 and IPv4 labelled unicast address family mode
- You cannot configure both LLGR and Extended Route Retention feature on the same neighbor.
- When you configure the Extended Route Retention feature, the capability attribute is not sent.

Configuration Example

Configure a route policy:

```
Router(config)# route-policy RRP_comm_no_export_local_pref_2500
Router(config-rpl)# set community RRP_comm_no_export additive
Router(config-rpl)# set local-preference 2500
Router(config-rpl)# end-policy
Router(config-rpl)# exit
Router(config)# route-policy comm_number_local_pref
Router(config-rpl)# set community comm_number
Router(config-rpl)# set local-preference 10000
Router(config-rpl)# end-policy
```

Apply route policy parameters to a neighbor:

```
Router(config)# router bgp 140
Router(config-bgp)# neighbor 10.1.1.1
Router(config-bgp-nbr)# remote-as 1
Router(config-bgp-nbr)# update-source Loopback 0
Router(config-bgp-nbr)# address-family ipv4 unicast
// Configure route-retention policy
Router(config-bgp-nbr-af)# route-policy RRP_comm_no_export_local_pref_2500 retention
retention-time 2340
// Configure the inbound route policy
Router(config-bgp-nbr-af)# route-policy comm_number_local_pref in
// Enables the view of the peer's adj-rib-in table
Router(config-bgp-nbr-af)# soft-reconfiguration inbound always
```

Verification

Verify the configured route-retention policy:

```
Router# show bgp neighbor 10.1.1.1
Fri Oct 22 04:52:44.972 PDT

BGP neighbor is 10.1.1.1
  Remote AS 1, local AS 1, internal link
  Remote router ID 10.1.1.1
  BGP state = Established, up for 00:03:03
...
  For Address Family: IPv4 Unicast
  BGP neighbor version 16172
  Policy for incoming advertisements is comm_number_local_pref
  Policy for Retention is RRP_comm_no_export_local_pref_2500
Configured route retention policy stale timer for routes is 2340 seconds
...
```

Verify the stale routes.

```
Router# show bgp ipv4 unicast 181.1.1.0/24
Fri Oct 22 04:56:15.906 PDT
...
Path #1: Received by speaker 0
  Advertised IPv4 Unicast paths to peers (in unique update groups):
    3.3.3.3
    100, (Received from a RR-client), (long-lived/route-retention policy stale)
    192.1.2.1 (metric 10) from 192.1.2.1 (10.1.1.1)
      Origin IGP, metric 1221, localpref 2500, valid, internal, best, group-best, multipath

      Received Path ID 0, Local Path ID 1, version 16243
      Community: 1:100 no-export
```

BGP Functional Overview

BGP uses TCP as its transport protocol. Two BGP routers form a TCP connection between one another (peer routers) and exchange messages to open and confirm the connection parameters.

BGP routers exchange network reachability information. This information is mainly an indication of the full paths (BGP autonomous system numbers) that a route should take to reach the destination network. This information helps construct a graph that shows which autonomous systems are loop free and where routing policies can be applied to enforce restrictions on routing behavior.

Any two routers forming a TCP connection to exchange BGP routing information are called peers or neighbors. BGP peers initially exchange their full BGP routing tables. After this exchange, incremental updates are sent as the routing table changes. BGP keeps a version number of the BGP table, which is the same for all of its BGP peers. The version number changes whenever BGP updates the table due to routing information changes. Keepalive packets are sent to ensure that the connection is alive between the BGP peers and notification packets are sent in response to error or special conditions.

Enable BGP Routing

Perform this task to enable BGP routing and establish a BGP routing process. Configuring BGP neighbors is included as part of enabling BGP routing.



Note

- At least one neighbor and at least one address family must be configured to enable BGP routing. At least one neighbor with both a remote AS and an address family must be configured globally using the **address family** and **remote as** commands.
- When one BGP session has both IPv4 unicast and IPv4 labeled-unicast AFI/SAF, then the routing behavior is nondeterministic. Therefore, the prefixes may not be correctly advertised. Incorrect prefix advertisement results in reachability issues. In order to avoid such reachability issues, you must explicitly configure a route policy to advertise prefixes either through IPv4 unicast or through IPv4 labeled-unicast address families.

Before you begin

BGP must be able to obtain a router identifier (for example, a configured loopback address). At least, one address family must be configured in the BGP router configuration and the same address family must also be configured under the neighbor.



Note

If the neighbor is configured as an external BGP (eBGP) peer, you must configure an inbound and outbound route policy on the neighbor using the **route-policy** command.

SUMMARY STEPS

1. **configure**
2. **route-policy** *route-policy-name*
3. **end-policy**
4. Use the **commit** or **end** command.
5. **configure**
6. **router bgp** *as-number*
7. **bgp router-id** *ip-address*
8. **address-family** { **ipv4** | **ipv6** } **unicast**
9. **exit**
10. **neighbor** *ip-address*
11. **remote-as** *as-number*
12. **address-family** { **ipv4** | **ipv6** } **unicast**

13. **route-policy** *route-policy-name* { **in** | **out** }
14. Use the **commit** or **end** command.

DETAILED STEPS

Step 1 **configure**

Example:

```
RP/0/RP0/CPU0:router# configure
```

Enters global configuration mode.

Step 2 **route-policy** *route-policy-name*

Example:

```
RP/0/RP0/CPU0:router(config)# route-policy drop-as-1234
RP/0/RP0/CPU0:router(config-rpl)# if as-path passes-through '1234' then
RP/0/RP0/CPU0:router(config-rpl)# apply check-communities
RP/0/RP0/CPU0:router(config-rpl)# else
RP/0/RP0/CPU0:router(config-rpl)# pass
RP/0/RP0/CPU0:router(config-rpl)# endif
```

(Optional) Creates a route policy and enters route policy configuration mode, where you can define the route policy.

Step 3 **end-policy**

Example:

```
RP/0/RP0/CPU0:router(config-rpl)# end-policy
```

(Optional) Ends the definition of a route policy and exits route policy configuration mode.

Step 4 Use the **commit** or **end** command.

commit —Saves the configuration changes and remains within the configuration session.

end —Prompts user to take one of these actions:

- **Yes** — Saves configuration changes and exits the configuration session.
- **No** —Exits the configuration session without committing the configuration changes.
- **Cancel** —Remains in the configuration session, without committing the configuration changes.

Step 5 **configure**

Example:

```
RP/0/RP0/CPU0:router# configure
```

Enters global configuration mode.

Step 6 **router bgp** *as-number*

Example:

```
RP/0/RP0/CPU0:router(config)# router bgp 120
```

Specifies the BGP AS number and enters the BGP configuration mode, allowing you to configure the BGP routing process.

Step 7 **bgp router-id** *ip-address*

Example:

```
RP/0/RP0/CPU0:router(config-bgp)# bgp router-id 192.168.70.24
```

Configures the local router with a specified router ID.

Step 8 **address-family** { **ipv4** | **ipv6** } **unicast**

Example:

```
RP/0/RP0/CPU0:router(config-bgp)# address-family ipv4 unicast
```

Specifies either the IPv4 or IPv6 address family and enters address family configuration submode. To see a list of all the possible keywords and arguments for this command, use the CLI help (?).

Step 9 **exit**

Example:

```
RP/0/RP0/CPU0:router(config-bgp-af)# exit
```

Exits the current configuration mode.

Step 10 **neighbor** *ip-address*

Example:

```
RP/0/RP0/CPU0:router(config-bgp)# neighbor 172.168.40.24
```

Places the router in neighbor configuration mode for BGP routing and configures the neighbor IP address as a BGP peer.

Step 11 **remote-as** *as-number*

Example:

```
RP/0/RP0/CPU0:router(config-bgp-nbr)# remote-as 2002
```

Creates a neighbor and assigns a remote autonomous system number to it.

Step 12 **address-family** { **ipv4** | **ipv6** } **unicast**

Example:

```
RP/0/RP0/CPU0:router(config-bgp-nbr)# address-family ipv4 unicast
```

Specifies either the IPv4 or IPv6 address family and enters address family configuration submode. To see a list of all the possible keywords and arguments for this command, use the CLI help (?).

Step 13 **route-policy** *route-policy-name* { **in** | **out** }

Example:

```
RP/0/RP0/CPU0:router(config-bgp-nbr-af)# route-policy drop-as-1234 in
```

(Optional) Applies the specified policy to inbound IPv4 unicast routes.

Step 14 Use the **commit** or **end** command.

commit —Saves the configuration changes and remains within the configuration session.

end —Prompts user to take one of these actions:

- **Yes** — Saves configuration changes and exits the configuration session.
- **No** —Exits the configuration session without committing the configuration changes.
- **Cancel** —Remains in the configuration session, without committing the configuration changes.

Enabling BGP: Example

The following shows how to enable BGP.

```
prefix-set static
  2020::/64,
  2012::/64,
  10.10.0.0/16,
  10.2.0.0/24
end-set

route-policy pass-all
  pass
end-policy
route-policy set_next_hop_agg_v4
  set next-hop 10.0.0.1
end-policy

route-policy set_next_hop_static_v4
  if (destination in static) then
    set next-hop 10.1.0.1
  else
    drop
  endif
end-policy

route-policy set_next_hop_agg_v6
  set next-hop 2003::121
end-policy

route-policy set_next_hop_static_v6
  if (destination in static) then
    set next-hop 2011::121
  else
    drop
  endif
end-policy

router bgp 65000
  bgp fast-external-fallover disable
  bgp confederation peers
    65001
```



```

65002
bgp confederation identifier 1
bgp router-id 1.1.1.1
address-family ipv4 unicast
  aggregate-address 10.2.0.0/24 route-policy set_next_hop_agg_v4
  aggregate-address 10.3.0.0/24
  redistribute static route-policy set_next_hop_static_v4
address-family ipv6 unicast
  aggregate-address 2012::/64 route-policy set_next_hop_agg_v6
  aggregate-address 2013::/64
  redistribute static route-policy set_next_hop_static_v6
neighbor 10.0.101.60
remote-as 65000
address-family ipv4 unicast
neighbor 10.0.101.61
remote-as 65000
address-family ipv4 unicast
neighbor 10.0.101.62
remote-as 3
address-family ipv4 unicast
  route-policy pass-all in
  route-policy pass-all out
neighbor 10.0.101.64
remote-as 5
update-source Loopback0
address-family ipv4 unicast
  route-policy pass-all in
  route-policy pass-all out

```

Adjust BGP Timers

BGP uses certain timers to control periodic activities, such as the sending of keepalive messages and the interval after which a neighbor is assumed to be down if no messages are received from the neighbor during the interval. The values set using the **timers bgp** command in router configuration mode can be overridden on particular neighbors using the **timers** command in the neighbor configuration mode.

Perform this task to set the timers for BGP neighbors.

SUMMARY STEPS

1. **configure**
2. **router bgp** *as-number*
3. **timers bgp** *keepalive hold-time*
4. **neighbor** *ip-address*
5. **timers** *keepalive hold-time*
6. Use the **commit** or **end** command.

DETAILED STEPS

Step 1 **configure**

Example:

```
RP/0/RP0/CPU0:router# configure
```

Enters global configuration mode.

Step 2 `router bgp` *as-number*

Example:

```
RP/0/RP0/CPU0:router(config)# router bgp 123
```

Specifies the autonomous system number and enters the BGP configuration mode, allowing you to configure the BGP routing process.

Step 3 `timers bgp` *keepalive hold-time*

Example:

```
RP/0/RP0/CPU0:router(config-bgp)# timers bgp 30 90
```

Sets a default keepalive time and a default hold time for all neighbors.

Step 4 `neighbor` *ip-address*

Example:

```
RP/0/RP0/CPU0:router(config-bgp)# neighbor 172.168.40.24
```

Places the router in neighbor configuration mode for BGP routing and configures the neighbor IP address as a BGP peer.

Step 5 `timers` *keepalive hold-time*

Example:

```
RP/0/RP0/CPU0:router(config-bgp-nbr)# timers 60 220
```

(Optional) Sets the keepalive timer and the hold-time timer for the BGP neighbor.

Step 6 Use the `commit` or `end` command.

commit —Saves the configuration changes and remains within the configuration session.

end —Prompts user to take one of these actions:

- **Yes** — Saves configuration changes and exits the configuration session.
- **No** —Exits the configuration session without committing the configuration changes.
- **Cancel** —Remains in the configuration session, without committing the configuration changes.

Change BGP Default Local Preference Value

Perform this task to set the default local preference value for BGP paths.

SUMMARY STEPS

1. `configure`
2. `router bgp` *as-number*
3. `bgp default local-preference` *value*

4. Use the **commit** or **end** command.

DETAILED STEPS

Step 1 **configure**

Example:

```
RP/0/RP0/CPU0:router# configure
```

Enters global configuration mode.

Step 2 **router bgp** *as-number*

Example:

```
RP/0/RP0/CPU0:router(config)# router bgp 120
```

Specifies the autonomous system number and enters the BGP configuration mode, allowing you to configure the BGP routing process.

Step 3 **bgp default local-preference** *value*

Example:

```
RP/0/RP0/CPU0:router(config-bgp)# bgp default local-preference 200
```

Sets the default local preference value from the default of 100, making it either a more preferable path (over 100) or less preferable path (under 100).

Step 4 Use the **commit** or **end** command.

commit —Saves the configuration changes and remains within the configuration session.

end —Prompts user to take one of these actions:

- **Yes** — Saves configuration changes and exits the configuration session.
- **No** —Exits the configuration session without committing the configuration changes.
- **Cancel** —Remains in the configuration session, without committing the configuration changes.

Configure MED Metric for BGP

Perform this task to set the multi exit discriminator (MED) to advertise to peers for routes that do not already have a metric set (routes that were received with no MED attribute).

SUMMARY STEPS

1. **configure**
2. **router bgp** *as-number*
3. **default-metric** *value*
4. Use the **commit** or **end** command.

DETAILED STEPS

Step 1 **configure****Example:**

```
RP/0/RP0/CPU0:router# configure
```

Enters global configuration mode.

Step 2 **router bgp** *as-number***Example:**

```
RP/0/RP0/CPU0:router(config)# router bgp 120
```

Specifies the autonomous system number and enters the BGP configuration mode, allowing you to configure the BGP routing process.

Step 3 **default-metric** *value***Example:**

```
RP/0/RP0/CPU0:router(config-bgp)# default-metric
```

Sets the default metric, which is used to set the MED to advertise to peers for routes that do not already have a metric set (routes that were received with no MED attribute).

Step 4 Use the **commit** or **end** command.

commit —Saves the configuration changes and remains within the configuration session.

end —Prompts user to take one of these actions:

- **Yes** — Saves configuration changes and exits the configuration session.
 - **No** —Exits the configuration session without committing the configuration changes.
 - **Cancel** —Remains in the configuration session, without committing the configuration changes.
-

Configure BGP Weights

A weight is a number that you can assign to a path so that you can control the best-path selection process. If you have particular neighbors that you want to prefer for most of your traffic, you can use the **weight** command to assign a higher weight to all routes learned from that neighbor. Perform this task to assign a weight to routes received from a neighbor.

SUMMARY STEPS

1. **configure**
2. **router bgp** *as-number*
3. **neighbor** *ip-address*
4. **remote-as** *as-number*

5. **address-family** { **ipv4** | **ipv6** } **unicast**
6. **weight** *weight-value*
7. Use the **commit** or **end** command.

DETAILED STEPS

Step 1 **configure**

Example:

```
RP/0/RP0/CPU0:router# configure
```

Enters global configuration mode.

Step 2 **router bgp** *as-number*

Example:

```
RP/0/RP0/CPU0:router(config)# router bgp 120
```

Specifies the autonomous system number and enters the BGP configuration mode, allowing you to configure the BGP routing process.

Step 3 **neighbor** *ip-address*

Example:

```
RP/0/RP0/CPU0:router(config-bgp)# neighbor 172.168.40.24
```

Places the router in neighbor configuration mode for BGP routing and configures the neighbor IP address as a BGP peer.

Step 4 **remote-as** *as-number*

Example:

```
RP/0/RP0/CPU0:router(config-bgp-nbr)# remote-as 2002
```

Creates a neighbor and assigns a remote autonomous system number to it.

Step 5 **address-family** { **ipv4** | **ipv6** } **unicast**

Example:

```
RP/0/RP0/CPU0:router(config-bgp-nbr)# address-family ipv4 unicast
```

Specifies either the IPv4 or IPv6 address family and enters address family configuration submenu.

To see a list of all the possible keywords and arguments for this command, use the CLI help (?).

Step 6 **weight** *weight-value*

Example:

```
RP/0/RP0/CPU0:router(config-bgp-nbr-af)# weight 41150
```

Assigns a weight to all routes learned through the neighbor.

Step 7 Use the **commit** or **end** command.

commit —Saves the configuration changes and remains within the configuration session.

end —Prompts user to take one of these actions:

- **Yes** — Saves configuration changes and exits the configuration session.
- **No** —Exits the configuration session without committing the configuration changes.
- **Cancel** —Remains in the configuration session, without committing the configuration changes.

What to do next

You the **clear bgp** command for the newly configured weight to take effect.

Tune BGP Best-Path Calculation

BGP routers typically receive multiple paths to the same destination. The BGP best-path algorithm determines the best path to install in the IP routing table and to use for forwarding traffic. The BGP best-path comprises of three steps:

- Step 1—Compare two paths to determine which is better.
- Step 2—Iterate over all paths and determines which order to compare the paths to select the overall best path.
- Step 3—Determine whether the old and new best paths differ enough so that the new best path should be used.



Note The order of comparison determined by Step 2 is important because the comparison operation is not transitive; that is, if three paths, A, B, and C exist, such that when A and B are compared, A is better, and when B and C are compared, B is better, it is not necessarily the case that when A and C are compared, A is better. This nontransitivity arises because the multi exit discriminator (MED) is compared only among paths from the same neighboring autonomous system (AS) and not among all paths. [BGP Best Path Algorithm, on page 15](#) provides additional conceptual details.

Perform this task to change the default BGP best-path calculation behavior.

SUMMARY STEPS

1. **configure**
2. **router bgp** *as-number*
3. **bgp bestpath med missing-as-worst**
4. **bgp bestpath med always**
5. **bgp bestpath med confed**
6. **bgp bestpath as-path ignore**
7. **bgp bestpath compare-routerid**
8. Use the **commit** or **end** command.

DETAILED STEPS

Step 1 **configure****Example:**

```
RP/0/RP0/CPU0:router# configure
```

Enters global configuration mode.

Step 2 **router bgp *as-number*****Example:**

```
RP/0/RP0/CPU0:router(config)# router bgp 126
```

Specifies the autonomous system number and enters the BGP configuration mode, allowing you to configure the BGP routing process.

Step 3 **bgp bestpath med missing-as-worst****Example:**

```
RP/0/RP0/CPU0:router(config-bgp)# bgp bestpath med missing-as-worst
```

Directs the BGP software to consider a missing MED attribute in a path as having a value of infinity, making this path the least desirable path.

Step 4 **bgp bestpath med always****Example:**

```
RP/0/RP0/CPU0:router(config-bgp)# bgp bestpath med always
```

Configures the BGP speaker in the specified autonomous system to compare MEDs among all the paths for the prefix, regardless of the autonomous system from which the paths are received.

Step 5 **bgp bestpath med confed****Example:**

```
RP/0/RP0/CPU0:router(config-bgp)# bgp bestpath med confed
```

Enables BGP software to compare MED values for paths learned from confederation peers.

Step 6 **bgp bestpath as-path ignore****Example:**

```
RP/0/RP0/CPU0:router(config-bgp)# bgp bestpath as-path ignore
```

Configures the BGP software to ignore the autonomous system length when performing best-path selection.

Step 7 **bgp bestpath compare-routerid****Example:**

```
RP/0/RP0/CPU0:router(config-bgp)# bgp bestpath compare-routerid
```

Configure the BGP speaker in the autonomous system to compare the router IDs of similar paths.

Step 8 Use the **commit** or **end** command.

commit —Saves the configuration changes and remains within the configuration session.

end —Prompts user to take one of these actions:

- **Yes** — Saves configuration changes and exits the configuration session.
- **No** —Exits the configuration session without committing the configuration changes.
- **Cancel** —Remains in the configuration session, without committing the configuration changes.

Set BGP Administrative Distance

An administrative distance is a rating of the trustworthiness of a routing information source. In general, the higher the value, the lower the trust rating. Normally, a route can be learned through more than one protocol. Administrative distance is used to discriminate between routes learned from more than one protocol. The route with the lowest administrative distance is installed in the IP routing table. By default, BGP uses the administrative distances shown in here:

Table 7: BGP Default Administrative Distances

Distance	Default Value	Function
External	20	Applied to routes learned from eBGP.
Internal	200	Applied to routes learned from iBGP.
Local	200	Applied to routes originated by the router.



Note Distance does not influence the BGP path selection algorithm, but it does influence whether BGP-learned routes are installed in the IP routing table.

Perform this task to specify the use of administrative distances that can be used to prefer one class of route over another.

SUMMARY STEPS

1. **configure**
2. **router bgp** *as-number*
3. **address-family** { **ipv4** | **ipv6** } **unicast**
4. **distance bgp** *external-distance internal-distance local-distance*
5. Use the **commit** or **end** command.

DETAILED STEPS

Step 1 **configure****Example:**

```
RP/0/RP0/CPU0:router# configure
```

Enters global configuration mode.

Step 2 **router bgp** *as-number***Example:**

```
RP/0/RP0/CPU0:router(config)# router bgp 120
```

Specifies the autonomous system number and enters the BGP configuration mode, allowing you to configure the BGP routing process.

Step 3 **address-family** { **ipv4** | **ipv6** } **unicast****Example:**

```
RP/0/RP0/CPU0:router(config-bgp)# address-family ipv4 unicast
```

Specifies either an IPv4 or IPv6 address family unicast and enters address family configuration submode.

To see a list of all the possible keywords and arguments for this command, use the CLI help (?).

Step 4 **distance bgp** *external-distance internal-distance local-distance***Example:**

```
RP/0/RP0/CPU0:router(config-bgp-af)# distance bgp 20 20 200
```

Sets the external, internal, and local administrative distances to prefer one class of routes over another. The higher the value, the lower the trust rating.

Step 5 Use the **commit** or **end** command.

commit —Saves the configuration changes and remains within the configuration session.

end —Prompts user to take one of these actions:

- **Yes** — Saves configuration changes and exits the configuration session.
- **No** —Exits the configuration session without committing the configuration changes.
- **Cancel** —Remains in the configuration session, without committing the configuration changes.

Indicate BGP Back-door Routes

In most cases, when a route is learned through eBGP, it is installed in the IP routing table because of its distance. Sometimes, however, two ASs have an IGP-learned back-door route and an eBGP-learned route.

Their policy might be to use the IGP-learned path as the preferred path and to use the eBGP-learned path when the IGP path is down.

Perform this task to set the administrative distance on an external Border Gateway Protocol (eBGP) route to that of a locally sourced BGP route, causing it to be less preferred than an Interior Gateway Protocol (IGP) route.

SUMMARY STEPS

1. **configure**
2. **router bgp** *as-number*
3. **address-family** { **ipv4** | **ipv6** } **unicast**
4. **network** { *ip-address / prefix-length* | *ip-address mask* } **backdoor**
5. Use the **commit** or **end** command.

DETAILED STEPS

Step 1 **configure**

Example:

```
RP/0/RP0/CPU0:router# configure
```

Enters global configuration mode.

Step 2 **router bgp** *as-number*

Example:

```
RP/0/RP0/CPU0:router(config)# router bgp 120
```

Specifies the autonomous system number and enters the BGP configuration mode, allowing you to configure the BGP routing process.

Step 3 **address-family** { **ipv4** | **ipv6** } **unicast**

Example:

```
RP/0/RP0/CPU0:router(config-bgp)# address-family ipv4 unicast
```

Specifies either the IPv4 or IPv6 address family and enters address family configuration submode.

To see a list of all the possible keywords and arguments for this command, use the CLI help (?).

Step 4 **network** { *ip-address / prefix-length* | *ip-address mask* } **backdoor**

Example:

```
RP/0/RP0/CPU0:router(config-bgp-af)# network 172.20.0.0/16
```

Configures the local router to originate and advertise the specified network.

Step 5 Use the **commit** or **end** command.

commit —Saves the configuration changes and remains within the configuration session.

end —Prompts user to take one of these actions:

- **Yes** — Saves configuration changes and exits the configuration session.
- **No** — Exits the configuration session without committing the configuration changes.
- **Cancel** — Remains in the configuration session, without committing the configuration changes.

Back Door: Example

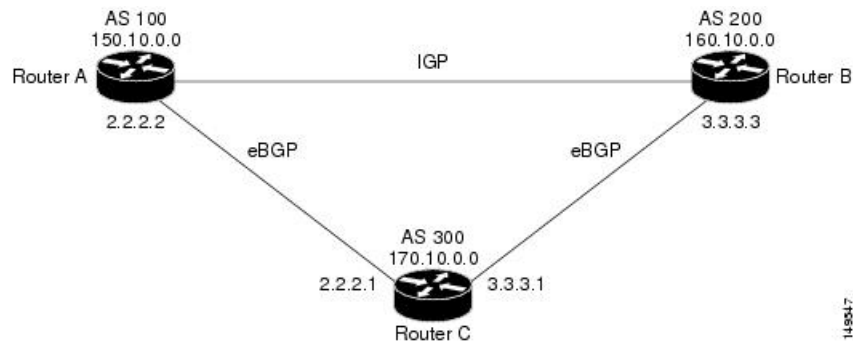

Here, Routers A and C and Routers B and C are running eBGP. Routers A and B are running an IGP (such as Routing Information Protocol [RIP], Interior Gateway Routing Protocol [IGRP], Enhanced IGRP, or Open Shortest Path First [OSPF]). The default distances for RIP, IGRP, Enhanced IGRP, and OSPF are 120, 100, 90, and 110, respectively. All these distances are higher than the default distance of eBGP, which is 20. Usually, the route with the lowest distance is preferred.

Router A receives updates about 160.10.0.0 from two routing protocols: eBGP and IGP. Because the default distance for eBGP is lower than the default distance of the IGP, Router A chooses the eBGP-learned route from Router C. If you want Router A to learn about 160.10.0.0 from Router B (IGP), establish a BGP back door. See .

In the following example, a network back-door is configured:

```
RP/0/RP0/CPU0:router(config)# router bgp 100
RP/0/RP0/CPU0:router(config-bgp)# address-family ipv4 unicast
RP/0/RP0/CPU0:router(config-bgp-af)# network 160.10.0.0/16 backdoor
```

Router A treats the eBGP-learned route as local and installs it in the IP routing table with a distance of 200. The network is also learned through Enhanced IGRP (with a distance of 90), so the Enhanced IGRP route is successfully installed in the IP routing table and is used to forward traffic. If the Enhanced IGRP-learned route goes down, the eBGP-learned route is installed in the IP routing table and is used to forward traffic.

Although BGP treats network 160.10.0.0 as a local entry, it does not advertise network 160.10.0.0 as it normally would advertise a local entry.

Configure Aggregate Addresses

Perform this task to create aggregate entries in a BGP routing table.

SUMMARY STEPS

1. **configure**
2. **router bgp** *as-number*
3. **address-family** { **ipv4** | **ipv6** } **unicast**
4. **aggregate-address** *address/mask-length* [**as-set**] [**as-confed-set**] [**summary-only**] [**route-policy** *route-policy-name*]
5. Use the **commit** or **end** command.

DETAILED STEPS**Step 1** **configure****Example:**

```
RP/0/RP0/CPU0:router# configure
```

Enters global configuration mode.

Step 2 **router bgp** *as-number***Example:**

```
RP/0/RP0/CPU0:router(config)# router bgp 120
```

Specifies the autonomous system number and enters the BGP configuration mode, allowing you to configure the BGP routing process.

Step 3 **address-family** { **ipv4** | **ipv6** } **unicast****Example:**

```
RP/0/RP0/CPU0:router(config-bgp)# address-family ipv4 unicast
```

Specifies either the IPv4 or IPv6 address family and enters address family configuration submode.

To see a list of all the possible keywords and arguments for this command, use the CLI help (?).

Step 4 **aggregate-address** *address/mask-length* [**as-set**] [**as-confed-set**] [**summary-only**] [**route-policy** *route-policy-name*]**Example:**

```
RP/0/RP0/CPU0:router(config-bgp-af)# aggregate-address 10.0.0.0/8 as-set
```

Creates an aggregate address. The path advertised for this route is an autonomous system set consisting of all elements contained in all paths that are being summarized.

- The **as-set** keyword generates autonomous system set path information and community information from contributing paths.
- The **as-confed-set** keyword generates autonomous system confederation set path information from contributing paths.
- The **summary-only** keyword filters all more specific routes from updates.

- The **route-policy** *route-policy-name* keyword and argument specify the route policy used to set the attributes of the aggregate route.

Step 5 Use the **commit** or **end** command.

commit —Saves the configuration changes and remains within the configuration session.

end —Prompts user to take one of these actions:

- **Yes** — Saves configuration changes and exits the configuration session.
- **No** —Exits the configuration session without committing the configuration changes.
- **Cancel** —Remains in the configuration session, without committing the configuration changes.

Understanding BGP MD5 Authentication

BGP provides a mechanism, known as Message Digest 5 (MD5) authentication, for authenticating a TCP segment between two BGP peers by using a clear text or encrypted password.

MD5 authentication is configured at the BGP neighbor level. BGP peers using MD5 authentication are configured with the same password. If the password authentication fails, then the packets are not transmitted along the segment.

Configuring BGP MD5 Authentication

You can use the configuration in this section to configure BGP MD5 authentication between two BGP peers.



Note The configuration for MD5 authentication is identical on both peers.

Configuration

Use the following configuration to configure BGP MD5:

```
RP/0/RP0/CPU0:router(config)# router bgp 50
RP/0/RP0/CPU0:router(config-bgp)# address-family ipv4 unicast
RP/0/RP0/CPU0:router(config-bgp-af)# exit
RP/0/RP0/CPU0:router(config-bgp)# neighbor 10.1.1.1
RP/0/RP0/CPU0:router(config-bgp-nbr)# remote-as 51
RP/0/RP0/CPU0:router(config-bgp-nbr)# password encrypted a1b2c3
RP/0/RP0/CPU0:router(config-bgp-nbr)# commit
```

Running Configuration

Validate the configuration.

```
RP/0/RP0/CPU0:router# show running-config
...
!
router bgp 50
address-family ipv4 unicast
!
neighbor 10.1.1.1
```

```

remote-as 51
password encrypted a1b2c3
!
!

```

Hiding the Local AS Number for BGP Networks

Changing the autonomous system number is necessary when two separate BGP networks are combined under a single autonomous system. The neighbor **local-as** command is used to configure BGP peers to support two local autonomous system numbers to maintain peering between two separate BGP networks.

However, when the neighbor **local-as** command is configured on a BGP peer, the local AS number is automatically prepended to all routes that are learned from eBGP peers by default. This behavior, however, makes changing the autonomous system number for a service provider or large BGP network difficult, because the routes with the prepended AS number are rejected by internal BGP (iBGP) peers that belong to the same AS.

Hiding the local AS number by using the **no-prepend** command simplifies the process of changing the autonomous system number in a Border Gateway Protocol (BGP) network. Without this feature, internal BGP (iBGP) peers reject external routes from peers with a local AS number in the as-path attribute to prevent routing loops. Hiding the local AS number allows you to transparently change the autonomous system number for the entire BGP network and ensure that routes can be propagated throughout the autonomous system, while the AS number transition is incomplete.

Configuring BGP to Hide the Local AS Number

Hiding the local AS number for eBGP peers by using the **no-prepend** command can be used to transparently change the AS number of a BGP network, and ensure that routes are propagated throughout the AS during the transition. Because the local AS number is not prepended to these routes, external routes are not rejected by internal peers during the transition from one AS number to another.

This section describes the configuration and verification of the feature.



Note BGP prepends the autonomous system number from each BGP network that a route traverses. This behavior is designed to maintain network reachability information and to prevent routing loops from occurring. Configuring the **no-prepend** command incorrectly could create routing loops. So, the configuration of this command should only be attempted by an experienced network operator.

Configuration

Use the following configuration to hide the local AS number for eBGP peers.

```

Router# config
Router(config)# router bgp 100
Router(config-bgp)# address-family ipv4 unicast
Router(config-bgp-af)# network 172.20.1.1 255.255.240.0
Router(config-bgp-af)# neighbor 172.20.1.1
Router(config-bgp-af)# remote-as 150
Router(config-bgp-af)# local-as 300 no-prepend
Router(config-bgp-af)# commit

```

Running Configuration

```
RP/0/RP0/CPU0:router# show running-configuration
...
!
router bgp 100
 address-family ipv4 unicast
  network 10.1.1.1 255.255.0.0
  neighbor 10.1.1.1 remote-as 100
  neighbor 10.1.1.1 local-as 300 no-prepend
!
```

Verification

Use the following command to verify your configuration.

```
RP/0/RP0/CPU0:router# show ip bgp neighbors
BGP neighbor is 10.1.1.1, remote AS 100, local AS 300 no-prepend, external link
BGP version 4, remote router ID 10.1.1.1
BGP state = Established, up for 00:00:49
Last read 00:00:49, hold time is 180, keepalive interval is 60 seconds
Neighbor capabilities:
Route refresh: advertised and received(new)
Address family IPv4 Unicast: advertised and received
IPv4 MPLS Label capability:
Received 10 messages, 1 notifications, 0 in queue
Sent 10 messages, 0 notifications, 0 in queue
Default minimum time between advertisement runs is 30 seconds
```

Autonomous System Number Formats in BGP

Autonomous system numbers (ASNs) are globally unique identifiers used to identify autonomous systems (ASs) and enable ASs to exchange exterior routing information between neighboring ASs. A unique ASN is allocated to each AS for use in BGP routing. ASNs are encoded as 2-byte numbers and 4-byte numbers in BGP.

```
RP/0/RP0/CPU0:router(config)# as-format [asdot | asplain]
RP/0/RP0/CPU0:router(config)# as-format asdot
```



Note ASN change for BGP process is not currently supported via **commit replace** command.

2-byte Autonomous System Number Format

The 2-byte ASNs are represented in asplain notation. The 2-byte range is 1 to 65535.

4-byte Autonomous System Number Format

To prepare for the eventual exhaustion of 2-byte Autonomous System Numbers (ASNs), BGP has the capability to support 4-byte ASNs. The 4-byte ASNs are represented both in asplain and asdot notations.

The byte range for 4-byte ASNs in asplain notation is 1-4294967295. The AS is represented as a 4-byte decimal number. The 4-byte ASN asplain representation is defined in [draft-ietf-idr-as-representation-01.txt](#).

For 4-byte ASNs in asdot format, the 4-byte range is 1.0 to 65535.65535 and the format is:

high-order-16-bit-value-in-decimal . low-order-16-bit-value-in-decimal

The BGP 4-byte ASN capability is used to propagate 4-byte-based AS path information across BGP speakers that do not support 4-byte AS numbers. See [draft-ietf-idr-as4bytes-12.txt](#) for information on increasing the size of an ASN from 2 bytes to 4 bytes. AS is represented as a 4-byte decimal number

as-format Command

The **as-format** command configures the ASN notation to asdot. The default value, if the **as-format** command is not configured, is asplain.

BGP Multi-Instance and Multi-AS

Multi-AS BGP enables configuring each instance of a multi-instance BGP with a different AS number. Multi-Instance and Multi-AS BGP provides these capabilities:

- Mechanism to consolidate the services provided by multiple routers using a common routing infrastructure into a single IOS-XR router.
- Mechanism to achieve AF isolation by configuring the different AFs in different BGP instances.
- Means to achieve higher session scale by distributing the overall peering sessions between multiple instances.
- Mechanism to achieve higher prefix scale (especially on a RR) by having different instances carrying different BGP tables.
- Improved BGP convergence under certain scenarios.
- All BGP functionalities including NSR are supported for all the instances.
- The load and commit router-level operations can be performed on previously verified or applied configurations.

Restrictions

- The router supports maximum of 4 BGP instances.
- Each BGP instance needs a unique router-id.
- Only one Address Family can be configured under each BGP instance (VPNv4, VPNv6 and RT-Constrain can be configured under multiple BGP instances).
- IPv4/IPv6 Unicast should be within the same BGP instance in which IPv4/IPv6 Labeled-Unicast is configured.
- IPv4/IPv6 Multicast should be within the same BGP instance in which IPv4/IPv6 Unicast is configured.
- All configuration changes for a single BGP instance can be committed together. However, configuration changes for multiple instances cannot be committed together.
- Cisco recommends that BGP update-source should be unique in the default VRF over all instances while peering with the same remote router.

Configure Multiple BGP Instances for a Specific Autonomous System

Perform this task to configure multiple BGP instances for a specific autonomous system. All configuration changes for a single BGP instance can be committed together. However, configuration changes for multiple instances cannot be committed together.

SUMMARY STEPS

1. **configure**
2. **router bgp** *as-number* [**instance** *instance name*]
3. **bgp router-id** *address*
4. Use the **commit** or **end** command.

DETAILED STEPS

Step 1 **configure****Example:**

```
RP/0/RP0/CPU0:router# configure
```

Enters global configuration mode.

Step 2 **router bgp** *as-number* [**instance** *instance name*]**Example:**

```
RP/0/RSP0/CPU0:router(config)# router bgp 100 instance inst1
```

Enters BGP configuration mode for the user specified BGP instance.

Step 3 **bgp router-id** *address***Example:**

```
RP/0/RSP0/CPU0:router(config-bgp)# bgp router-id 10.0.0.0
```

Configures a fixed router ID for the BGP-speaking router (BGP instance).

Note You must manually configure unique router ID for each BGP instance.

Step 4 Use the **commit** or **end** command.

commit —Saves the configuration changes and remains within the configuration session.

end —Prompts user to take one of these actions:

- **Yes** — Saves configuration changes and exits the configuration session.
 - **No** —Exits the configuration session without committing the configuration changes.
 - **Cancel** —Remains in the configuration session, without committing the configuration changes.
-

BGP Routing Domain Confederation

One way to reduce the iBGP mesh is to divide an autonomous system into multiple sub-autonomous systems and group them into a single confederation. To the outside world, the confederation looks like a single autonomous system. Each autonomous system is fully meshed within itself and has a few connections to other autonomous systems in the same confederation. Although the peers in different autonomous systems have eBGP sessions, they exchange routing information as if they were iBGP peers. Specifically, the next hop, MED, and local preference information is preserved. This feature allows you to retain a single IGP for all of the autonomous systems.

Configure Routing Domain Confederation for BGP

Perform this task to configure the routing domain confederation for BGP. This includes specifying a confederation identifier and autonomous systems that belong to the confederation.

Configuring a routing domain confederation reduces the internal BGP (iBGP) mesh by dividing an autonomous system into multiple autonomous systems and grouping them into a single confederation. Each autonomous system is fully meshed within itself and has a few connections to another autonomous system in the same confederation. The confederation maintains the next hop and local preference information, and that allows you to retain a single Interior Gateway Protocol (IGP) for all autonomous systems. To the outside world, the confederation looks like a single autonomous system.

SUMMARY STEPS

1. **configure**
2. **router bgp** *as-number*
3. **bgp confederation identifier** *as-number*
4. **bgp confederation peers** *as-number*
5. Use the **commit** or **end** command.

DETAILED STEPS

Step 1 **configure****Example:**

```
RP/0/RP0/CPU0:router# configure
```

Enters global configuration mode.

Step 2 **router bgp** *as-number***Example:**

```
RP/0/RP0/CPU0:router# router bgp 120
```

Specifies the autonomous system number and enters the BGP configuration mode, allowing you to configure the BGP routing process.

Step 3 **bgp confederation identifier** *as-number***Example:**

```
RP/0/RP0/CPU0:router(config-bgp)# bgp confederation identifier 5
```

Specifies a BGP confederation identifier.

Step 4 **bgp confederation peers** *as-number*

Example:

```
RP/0/RP0/CPU0:router(config-bgp)# bgp confederation peers 1091
RP/0/RP0/CPU0:router(config-bgp)# bgp confederation peers 1092
RP/0/RP0/CPU0:router(config-bgp)# bgp confederation peers 1093
RP/0/RP0/CPU0:router(config-bgp)# bgp confederation peers 1094
RP/0/RP0/CPU0:router(config-bgp)# bgp confederation peers 1095
RP/0/RP0/CPU0:router(config-bgp)# bgp confederation peers 1096
```

Specifies that the BGP autonomous systems belong to a specified BGP confederation identifier. You can associate multiple AS numbers to the same confederation identifier, as shown in the example.

Step 5 Use the **commit** or **end** command.

commit —Saves the configuration changes and remains within the configuration session.

end —Prompts user to take one of these actions:

- **Yes** — Saves configuration changes and exits the configuration session.
- **No** —Exits the configuration session without committing the configuration changes.
- **Cancel** —Remains in the configuration session, without committing the configuration changes.

BGP Confederation: Example

The following is a sample configuration that shows several peers in a confederation. The confederation consists of three internal autonomous systems with autonomous system numbers 6001, 6002, and 6003. To the BGP speakers outside the confederation, the confederation looks like a normal autonomous system with autonomous system number 666 (specified using the **bgp confederation identifier** command).

In a BGP speaker in autonomous system 6001, the **bgp confederation peers** command marks the peers from autonomous systems 6002 and 6003 as special eBGP peers. Hence, peers 171.16.232.55 and 171.16.232.56 get the local preference, next hop, and MED unmodified in the updates. The router at 171.19.69.1 is a normal eBGP speaker, and the updates received by it from this peer are just like a normal eBGP update from a peer in autonomous system 666.

```
router bgp 6001
  bgp confederation identifier 666
  bgp confederation peers
    6002
    6003
  exit
address-family ipv4 unicast
  neighbor 171.16.232.55
  remote-as 6002
  exit
address-family ipv4 unicast
```

```

neighbor 171.16.232.56
remote-as 6003
exit
address-family ipv4 unicast
neighbor 171.19.69.1
remote-as 777

```

In a BGP speaker in autonomous system 6002, the peers from autonomous systems 6001 and 6003 are configured as special eBGP peers. Peer 171.17.70.1 is a normal iBGP peer, and peer 199.99.99.2 is a normal eBGP peer from autonomous system 700.

```

router bgp 6002
  bgp confederation identifier 666
  bgp confederation peers
    6001
    6003
  exit
  address-family ipv4 unicast
  neighbor 171.17.70.1
  remote-as 6002
  exit
  address-family ipv4 unicast
  neighbor 171.19.232.57
  remote-as 6001
  exit
  address-family ipv4 unicast
  neighbor 171.19.232.56
  remote-as 6003
  exit
  address-family ipv4 unicast
  neighbor 171.19.99.2
  remote-as 700
  exit
  address-family ipv4 unicast
  route-policy pass-all in
  route-policy pass-all out

```

In a BGP speaker in autonomous system 6003, the peers from autonomous systems 6001 and 6002 are configured as special eBGP peers. Peer 192.168.200.200 is a normal eBGP peer from autonomous system 701.

```

router bgp 6003
  bgp confederation identifier 666
  bgp confederation peers
    6001
    6002
  exit
  address-family ipv4 unicast
  neighbor 171.19.232.57
  remote-as 6001
  exit
  address-family ipv4 unicast
  neighbor 171.19.232.55
  remote-as 6002
  exit
  address-family ipv4 unicast
  neighbor 192.168.200.200
  remote-as 701

```

```

    exit
  address-family ipv4 unicast
    route-policy pass-all in
    route-policy pass-all out
  
```

The following is a part of the configuration from the BGP speaker 192.168.200.205 from autonomous system 701 in the same example. Neighbor 171.16.232.56 is configured as a normal eBGP speaker from autonomous system 666. The internal division of the autonomous system into multiple autonomous systems is not known to the peers external to the confederation.

```

router bgp 701
  address-family ipv4 unicast
    neighbor 172.16.232.56
      remote-as 666
    exit
  address-family ipv4 unicast
    route-policy pass-all in
    route-policy pass-all out
  exit
  address-family ipv4 unicast
    neighbor 192.168.200.205
      remote-as 701
  
```

BGP Additional Paths

The Border Gateway Protocol (BGP) Additional Paths feature modifies the BGP protocol machinery for a BGP speaker to be able to send multiple paths for a prefix. This gives 'path diversity' in the network. The add path enables BGP prefix independent convergence (PIC) at the edge routers.

BGP add path enables add path advertisement in an iBGP network and advertises the following types of paths for a prefix:

- Backup paths—to enable fast convergence and connectivity restoration.
- Group-best paths—to resolve route oscillation.
- All paths—to emulate an iBGP full-mesh.

Configure BGP Additional Paths

Perform these tasks to configure BGP Additional Paths capability:

SUMMARY STEPS

1. **configure**
2. **route-policy** *route-policy-name*
3. **if** *conditional-expression* **then** *action-statement* **else**
4. **pass endif**
5. **end-policy**
6. **router bgp** *as-number*
7. **address-family** {**ipv4** {**unicast** } | **ipv6** {**unicast** | **l2vpn** **vpws** | **vpn4** **unicast** | **vpn6** **unicast** } }

8. **additional-paths receive**
9. **additional-paths send**
10. **additional-paths selection route-policy route-policy-name**
11. Use the **commit** or **end** command.

DETAILED STEPS

Step 1 **configure**

Example:

```
RP/0/RP0/CPU0:router# configure
```

Enters global configuration mode.

Step 2 **route-policy route-policy-name**

Example:

```
RP/0/RP0/CPU0:router (config)#route-policy add_path_policy
```

Defines the route policy and enters route-policy configuration mode.

Step 3 **if conditional-expression then action-statement else**

Example:

```
RP/0/RP0/CPU0:router (config-rpl)#if community matches-any (*) then
    set path-selection all advertise
    else
```

Decides the actions and dispositions for the given route.

Step 4 **pass endif**

Example:

```
RP/0/RP0/CPU0:router (config-rpl-else)#pass
RP/0/RP0/CPU0:router (config-rpl-else)#endif
```

Passes the route for processing and ends the if statement.

Step 5 **end-policy**

Example:

```
RP/0/RP0/CPU0:router (config-rpl)#end-policy
```

Ends the route policy definition of the route policy and exits route-policy configuration mode.

Step 6 **router bgp as-number**

Example:

```
RP/0/RP0/CPU0:router (config)#router bgp 100
```

Specifies the autonomous system number and enters the BGP configuration mode, allowing you to configure the BGP routing process.

Step 7 **address-family {ipv4 {unicast } | ipv6 {unicast | l2vpn vpls-vpws | vpnv4 unicast | vpnv6 unicast } }**

Example:

```
RP/0/RP0/CPU0:router(config-bgp)#address-family ipv4 unicast
```

Specifies the address family and enters address family configuration submode.

Step 8 additional-paths receive

Example:

```
RP/0/RP0/CPU0:router(config-bgp-af)#additional-paths receive
```

Configures receive capability of multiple paths for a prefix to the capable peers.

Step 9 additional-paths send

Example:

```
RP/0/RP0/CPU0:router(config-bgp-af)#additional-paths send
```

Configures send capability of multiple paths for a prefix to the capable peers .

Step 10 additional-paths selection route-policy route-policy-name

Example:

```
RP/0/RP0/CPU0:router(config-bgp-af)#additional-paths selection route-policy add_path_policy
```

Configures additional paths selection capability for a prefix.

Step 11 Use the **commit** or **end** command.

commit —Saves the configuration changes and remains within the configuration session.

end —Prompts user to take one of these actions:

- **Yes** — Saves configuration changes and exits the configuration session.
- **No** —Exits the configuration session without committing the configuration changes.
- **Cancel** —Remains in the configuration session, without committing the configuration changes.

128-Multipath ECMP

Table 8: Feature History Table

Feature Name	Release Information	Feature Description
--------------	---------------------	---------------------

The 128-Multipath ECMP feature enables the router to support up to 128 parallel multipaths to a destination. BGP multipath functionality enables you to create multiple BGP paths, both internal and external, to the FIB and RIB. The availability of multiple BGP paths allows BGP to load-balance traffic over multiple links.

Equal-cost multi-path routing (ECMP) is a routing strategy where next-hop packet forwarding to a single destination can occur over multiple “best paths” which tie for top place in routing metric calculations. Multipath routing can be used in conjunction with most routing protocols, since it is a per-hop decision that is limited to a single router. It potentially offers substantial increases in bandwidth by load-balancing traffic over multiple paths. 128-path ECMP feature enables the router to support up to 128 parallel paths to a destination.

NCS 5500 Series Routers supports configuration of up to 128 ECMP next hops for BGP in IPv4 and IPv6. Support for a maximum of 128 path ECMP is available in the global table for BGP, particularly in iBGP and

eBGP prefixes. High Availability supports 128 ECMPs where all prefixes and paths are synchronised to a standby RIB.

Restrictions

- 128-path ECMP is applicable to global routes only; it is not applicable to VRF routes.
- BGP VRF routes support 32-path ECMP
- VRF and global tables in IGP maximum paths support 64-path ECMP.
- BGP and IGP in UCMP support 64-path ECMP.

Configure 128-Multipath BGP ECMP

- Configure 128-Multipath ECMP in iBGP
- Configure 128-Multipath ECMP in eBGP
- Configure 128-Multipath ECMP in eiBGP



Note You can either configure eBGP multipath or iBGP multipath, or both together. However, if eiBGP multipath configuration is already present, you cannot configure iBGP multipath or eBGP multipath. You have to unconfigure eiBGP mutipath configuration to configure iBGP or eBGP multipath configuration.

Configuration

Configure 128-Multipath ECMP in iBGP

```
Router(config)#router bgp 100
Router(config-bgp)#bgp router-id 10.10.10.11
Router(config-bgp)#address-family ipv4 unicast
Router(config-bgp-af)#maximum-paths ibgp 128
Router(config-bgp-af)#exit
Router(config-bgp)#address-family ipv6 unicast
Router(config-bgp-af)#maximum-paths ibgp 128
Router(config-bgp-af)#commit
```

Configure 128-Multipath ECMP in eBGP

```
Router(config)#router bgp 100
Router(config-bgp)#bgp router-id 10.10.10.11
Router(config-bgp)#address-family ipv4 unicast
Router(config-bgp-af)#maximum-paths ebgp 128
Router(config-bgp-af)#exit
Router(config-bgp)#address-family ipv6 unicast
Router(config-bgp-af)#maximum-paths ebgp 128
Router(config-bgp-af)#commit
```

Configure 128-Multipath ECMP in eiBGP

```
Router(config)#router bgp 100
Router(config-bgp)#bgp router-id 10.10.10.11
Router(config-bgp)#address-family ipv4 unicast
```



```

Router(config-bgp-af)#maximum-paths eibgp 128
Router(config-bgp-af)#exit
Router(config-bgp)#address-family ipv6 unicast
Router(config-bgp-af)#maximum-paths eibgp 128
Router(config-bgp-af)#commit

```

Running Configuration

The following is the running configuration for 128-multipath ECMP in iBGP.

```

Router# show run router bgp
router bgp 100
  bgp router-id 10.10.10.11
  address-family ipv4 unicast
    maximum-paths ibgp 128
  !
  address-family ipv6 unicast
    maximum-paths ibgp 128

```

The following is the running configuration for 128-multipath ECMP in eBGP.

```

router bgp 100
  bgp router-id 10.10.10.11
  address-family ipv4 unicast
    maximum-paths ebgp 128
  !
  address-family ipv6 unicast
    maximum-paths ebgp 128

```

The following is the running configuration for 128-multipath ECMP in eIBGP.

```

router bgp 100
  bgp router-id 10.10.10.11
  address-family ipv4 unicast
    maximum-paths eibgp 128
  !
  address-family ipv6 unicast
    maximum-paths eibgp 128

```

Verification

Verify the BGP multipath marking.

```

Router# show bgp 192.0.2.254/24
Fri Aug 14 13:59:45.190 UTC
BGP routing table entry for 191.1.0.0/24
Versions:
  Process          bRIB/RIB  SendTblVer
  Speaker          11008    11008
Last Modified: Aug 14 13:59:39.403 for 00:00:05
Paths: (35 available, best #1)
  Advertised IPv4 Unicast paths to peers (in unique update groups):
    100.101.3.2
  Path #1: Received by speaker 0
  Advertised IPv4 Unicast paths to peers (in unique update groups):
    100.101.3.2
  Local, (received & used)
    120.0.101.1 from 120.0.101.1 (120.0.101.1)
      Origin IGP, localpref 100, valid, internal, best, group-best, multipath
      Received Path ID 0, Local Path ID 1, version 7708
  Path #2: Received by speaker 0

```

```

Advertised IPv4 Unicast paths to peers (in unique update groups):
 100.101.3.2
Local, (received & used)
 120.0.102.1 from 120.0.102.1 (120.0.102.1)
  Origin IGP, localpref 100, valid, internal, multipath
  Received Path ID 0, Local Path ID 6, version 11008
.....
Path #128: Received by speaker 0
Advertised IPv4 Unicast paths to peers (in unique update groups):
 100.101.3.2
Local, (received & used)
 120.0.227.1 from 120.0.227.1 (120.0.227.1)
  Origin IGP, localpref 100, valid, internal, multipath
  Received Path ID 0, Local Path ID 6, version 14008

```

Verify the BGP multipath marking in FIB.

```

Router# show cef 192.0.2.254/24
Fri Aug 14 14:09:50.987 UTC
191.1.0.0/24, version 46115, internal 0x5000001 0x40 (ptr 0xd236928) [1], 0x0 (0xe715668),
0x0 (0x0)
Updated Aug 14 13:59:39.007
Prefix Len 24, traffic index 0, precedence n/a, priority 4
  via 120.0.101.1/32, 3 dependencies, recursive, bgp-multipath [flags 0x6080]
    path-idx 0 NHID 0x0 [0xd236a00 0x0]
    next hop 120.0.101.1/32 via 120.0.101.1/32
  via 120.0.102.1/32, 3 dependencies, recursive, bgp-multipath [flags 0x6080]
    path-idx 1 NHID 0x0 [0xde9a6d0 0x0]
    next hop 120.0.102.1/32 via 120.0.102.1/32
  via 120.0.103.1/32, 3 dependencies, recursive, bgp-multipath [flags 0x6080]
    path-idx 2 NHID 0x0 [0xde9a010 0x0]
  ...
  via 120.0.227.1/32, 3 dependencies, recursive, bgp-multipath [flags 0x6080]
    path-idx 127 NHID 0x0 [0xde9a010 0x0]

```

Verify the BGP multipath marking in RIB.

```

Routing# show route 192.0.2.254/24
Fri Aug 14 14:11:27.403 UTC

Routing entry for 191.1.0.0/24
  Known via "bgp 1", distance 200, metric 0, type internal
  Installed Aug 14 13:59:38.971 for 00:11:48
  Routing Descriptor Blocks
    120.0.101.1, from 120.0.101.1, BGP multi path
      Route metric is 0
    120.0.102.1, from 120.0.102.1, BGP multi path
      Route metric is 0
  ...
    120.0.227.1, from 120.0.227.1, BGP multi path
      Route metric is 0

```

Verify the total number of IPv4 ECMP paths

```

Router# show bgp ipv4 unicast 191.1.0.0/24 | i multipath | utility wc -l
Tue Jun 30 12:40:52.432 UTC
128

```

Verify the total number of IPv6 ECMP paths.

```

Router# show bgp ipv6 unicast 191:1::/64 | i multipath | utility wc -l
Tue Jun 30 12:42:28.893 UTC
128

```

Verify the IPv4 128-multipath ECMP.

```
Router# show route ipv4 191.1.0.0/24 | i multipath | utility wc -l
Tue Jun 30 12:40:53.253 UTC
128
Router# show cef ipv4 191.1.0.0/24 | i multipath | utility wc -l
Tue Jun 30 12:40:53.864 UTC
128
```

Verify the IPv6 128-multipath ECMP.

```
Router# show route ipv6 191:1::/64 | i multi | utility wc -l
Tue Jun 30 12:42:29.709 UTC
128
Router# show cef ipv6 191:1::/64 | i multipath | utility wc -l
Tue Jun 30 12:42:30.332 UTC
128
```

Verify the ECMP capabilities of the platform.

```
Router# show cef misc
Platform capabilities:
-----
L3 loadbalancing levels: 2
L3 Hash buckets: 64
L3 recursive Hash buckets: 128
L3 Unequal cost hash buckets: 64
```

BGP Maximum Prefix

The maximum-prefix feature imposes a maximum limit on the number of prefixes that are received from a neighbor for a given address family. Whenever the number of prefixes received exceeds the maximum number configured, the BGP session is terminated, which is the default behavior, after sending a cease notification to the neighbor. The session is down until a manual clear is performed by the user. The session can be resumed by using the **clear bgp** command. It is possible to configure a period after which the session can be automatically brought up by using the **maximum-prefix** command with the **restart** keyword. The maximum prefix limit can be configured by the user. Default limits are used if the user does not configure the maximum number of prefixes for the address family.

Discard Extra Paths

An option to discard extra paths is added to the maximum-prefix configuration. Configuring the discard extra paths option drops all excess prefixes received from the neighbor when the prefixes exceed the configured maximum value. This drop does not, however, result in session flap.

The benefits of discard extra paths option are:

- Limits the memory footprint of BGP.
- Stops the flapping of the peer if the paths exceed the set limit.

When the discard extra paths configuration is removed, BGP sends a route-refresh message to the neighbor if it supports the refresh capability; otherwise the session is flapped.

On the same lines, the following describes the actions when the maximum prefix value is changed:

- If the maximum value alone is changed, a route-refresh message is sourced, if applicable.
- If the new maximum value is greater than the current prefix count state, the new prefix states are saved.

- If the new maximum value is less than the current prefix count state, then some existing prefixes are deleted to match the new configured state value.

There is currently no way to control which prefixes are deleted.

Configure Discard Extra Paths

The discard extra paths option in the maximum-prefix configuration allows you to drop all excess prefixes received from the neighbor when the prefixes exceed the configured maximum value. This drop does not, however, result in session flap.

The benefits of discard extra paths option are:

- Limits the memory footprint of BGP.
- Stops the flapping of the peer if the paths exceed the set limit.

When the discard extra paths configuration is removed, BGP sends a route-refresh message to the neighbor if it supports the refresh capability; otherwise the session is flapped.



Note

- When the router drops prefixes, it is inconsistent with the rest of the network, resulting in possible routing loops.
- If prefixes are dropped, the standby and active BGP sessions may drop different prefixes. Consequently, an NSR switchover results in inconsistent BGP tables.
- The discard extra paths configuration cannot co-exist with the *soft reconfig* configuration.
- When the system runs out of physical memory, bgp process exits and you must manually restart bpm. To manually restart, use the **process restart bpm** command.

Perform this task to configure BGP maximum-prefix discard extra paths.

SUMMARY STEPS

1. **configure**
2. **router bgp** *as-number*
3. **neighbor** *ip-address*
4. **address-family** { **ipv4** | **ipv6** } **unicast**
5. **maximum-prefix** *maximum* **discard-extra-paths**
6. Use the **commit** or **end** command.

DETAILED STEPS

Step 1 **configure**

Example:

```
RP/0/RP0/CPU0:router# configure
```

Enters XR Config mode.

Step 2 `router bgp` *as-number***Example:**

```
RP/0/RP0/CPU0:router(config)# router bgp 10
```

Specifies the autonomous system number and enters the BGP configuration mode, allowing you to configure the BGP routing process.

Step 3 `neighbor` *ip-address***Example:**

```
RP/0/RP0/CPU0:router(config-bgp)# neighbor 10.0.0.1
```

Places the router in neighbor configuration mode for BGP routing and configures the neighbor IP address as a BGP peer.

Step 4 `address-family { ipv4 | ipv6 } unicast`**Example:**

```
RP/0/RP0/CPU0:router(config-bgp-nbr)# address-family ipv4 unicast
```

Specifies either the IPv4 or IPv6 address family and enters address family configuration submenu.

Step 5 `maximum-prefix` *maximum* `discard-extra-paths`**Example:**

```
RP/0/RP0/CPU0:router(config-bgp-nbr-af)# maximum-prefix 1000 discard-extra-paths
```

Configures a limit to the number of prefixes allowed.

Configures discard extra paths to discard extra paths when the maximum prefix limit is exceeded.

Step 6 Use the `commit` or `end` command.

commit —Saves the configuration changes and remains within the configuration session.

end —Prompts user to take one of these actions:

- **Yes** — Saves configuration changes and exits the configuration session.
- **No** —Exits the configuration session without committing the configuration changes.
- **Cancel** —Remains in the configuration session, without committing the configuration changes.

Example

The following example shows how to configure discard extra paths feature for the IPv4 address family:

```
RP/0/RP0/CPU0:router# configure
RP/0/RP0/CPU0:router(config)# router bgp 10
RP/0/RP0/CPU0:router(config-bgp)# neighbor 10.0.0.1
RP/0/RP0/CPU0:router(config-bgp-nbr)# address-family ipv4 unicast
RP/0/RP0/CPU0:router(config-bgp-nbr-af)# maximum-prefix 1000 discard-extra-paths
RP/0/RP0/CPU0:router(config-bgp-vrf-af)# commit
```

and is sent to other PEs as the backup path. BGP calculates the best–external path only when the best path is an iBGP path. If the best path is an eBGP path, then best–external path calculation is not required.

The procedure to determine the best–external path is as follows:

1. Determine the best path from the entire set of paths available for a prefix.
2. Eliminate the current best path.
3. Eliminate all the internal paths for the prefix.
4. From the remaining paths, eliminate all the paths that have the same next hop as that of the current best path.
5. Rerun the best path algorithm on the remaining set of paths to determine the best–external path.

BGP considers the external and confederations BGP paths for a prefix to calculate the best–external path. BGP advertises the best path and the best–external path as follows:

- On the primary PE—advertises the best path for a prefix to both its internal and external peers
- On the backup PE—advertises the best path selected for a prefix to the external peers and advertises the best–external path selected for that prefix to the internal peers

Configure Best-External Path Advertisement

Perform the following tasks to advertise the best–external path to the iBGP and route-reflector peers:

SUMMARY STEPS

1. **configure**
2. **router bgp** *as-number*
3. Do one of the following
 - **address-family** { **vpn4 unicast** | **vpn6 unicast** }
 - **vrfvrf-name**{**ipv4 unicast**|**ipv6 unicast**}
4. **advertise best-external**
5. Use the **commit** or **end** command.

DETAILED STEPS

Step 1 **configure**

Example:

```
RP/0/RP0/CPU0:router# configure
```

Enters global configuration mode.

Step 2 **router bgp** *as-number*

Example:

```
RP/0/RP0/CPU0:router(config)# router bgp 100
```

Specifies the autonomous system number and enters the BGP configuration mode, allowing you to configure the BGP routing process.

Step 3 Do one of the following

- **address-family** { **vpn4 unicast** | **vpn6 unicast** }
- **vrfvrf-name**{**ipv4 unicast|ipv6 unicast**}

Example:

```
RP/0/RP0/CPU0:router(config-bgp)# address-family vpn4 unicast
```

Specifies the address family or VRF address family and enters the address family or VRF address family configuration submode.

Step 4 **advertise best-external**

Example:

```
RP/0/RP0/CPU0:router(config-bgp-af)# advertise best-external
```

Advertise the best-external path to the iBGP and route-reflector peers.

Step 5 Use the **commit** or **end** command.

commit —Saves the configuration changes and remains within the configuration session.

end —Prompts user to take one of these actions:

- **Yes** — Saves configuration changes and exits the configuration session.
- **No** —Exits the configuration session without committing the configuration changes.
- **Cancel** —Remains in the configuration session, without committing the configuration changes.

BGP Local Label Retention

When a primary PE-CE link fails, BGP withdraws the route corresponding to the primary path along with its local label and programs the backup path in the Routing Information Base (RIB) and the Forwarding Information Base (FIB), by default.

However, until all the internal peers of the primary PE reconverge to use the backup path as the new bestpath, the traffic continues to be forwarded to the primary PE with the local label that was allocated for the primary path. Hence the previously allocated local label for the primary path must be retained on the primary PE for some configurable time after the reconvergence. BGP Local Label Retention feature enables the retention of the local label for a specified period. If no time is specified, the local label is retained for a default value of five minutes.

Retain Allocated Local Label for Primary Path

Perform the following tasks to retain the previously allocated local label for the primary path on the primary PE for some configurable time after reconvergence:

SUMMARY STEPS

1. **configure**
2. **router bgp** *as-number*
3. **address-family** { **vpn4 unicast** | **vpn6 unicast** }
4. **retain local-label** *minutes*
5. Use the **commit** or **end** command.

DETAILED STEPS

Step 1 **configure**

Example:

```
RP/0/RP0/CPU0:router# configure
```

Enters global configuration mode.

Step 2 **router bgp** *as-number*

Example:

```
RP/0/RP0/CPU0:router(config)# router bgp 100
```

Specifies the autonomous system number and enters the BGP configuration mode, allowing you to configure the BGP routing process.

Step 3 **address-family** { **vpn4 unicast** | **vpn6 unicast** }

Example:

```
RP/0/RP0/CPU0:router(config-bgp)# address-family vpn4 unicast
```

Specifies the address family and enters the address family configuration submode.

Step 4 **retain local-label** *minutes*

Example:

```
RP/0/RP0/CPU0:router(config-bgp-af)# retain local-label 10
```

Retains the previously allocated local label for the primary path on the primary PE for 10 minutes after reconvergence.

Step 5 Use the **commit** or **end** command.

commit —Saves the configuration changes and remains within the configuration session.

end —Prompts user to take one of these actions:

- **Yes** — Saves configuration changes and exits the configuration session.
 - **No** —Exits the configuration session without committing the configuration changes.
 - **Cancel** —Remains in the configuration session, without committing the configuration changes.
-

Allocated Local Label Retention: Example

The following example shows how to retain the previously allocated local label for the primary path on the primary PE for 10 minutes after reconvergence:

```
router bgp 100
address-family l2vpn vpnv4 unicast
  retain local-label 10
end
```

iBGP Multipath Load Sharing

When a Border Gateway Protocol (BGP) speaking router that has no local policy configured, receives multiple network layer reachability information (NLRI) from the internal BGP (iBGP) for the same destination, the router will choose one iBGP path as the best path. The best path is then installed in the IP routing table of the router. The iBGP Multipath Load Sharing feature enables the BGP speaking router to select multiple iBGP paths as the best paths to a destination. The best paths or multipaths are then installed in the IP routing table of the router.

[iBGP Multipath Load Sharing Reference, on page 25](#) provides additional details.

Configure iBGP Multipath Load Sharing

Perform this task to configure the iBGP Multipath Load Sharing:

SUMMARY STEPS

1. **configure**
2. **router bgp** *as-number*
3. **address-family** {*ipv4|ipv6*} {*unicast|multicast*}
4. **maximum-paths ibgp** *number*
5. Use the **commit** or **end** command.

DETAILED STEPS

Step 1 **configure**

Example:

```
RP/0/RP0/CPU0:router# configure
```

Enters global configuration mode.

Step 2 **router bgp** *as-number*

Example:

```
RP/0/RP0/CPU0:router(config)# router bgp 100
```

Specifies the autonomous system number and enters the BGP configuration mode, allowing you to configure the BGP routing process.

Step 3 `address-family {ipv4|ipv6} {unicast|multicast}`

Example:

```
RP/0/RP0/CPU0:router(config-bgp)# address-family ipv4 multicast
```

Specifies either the IPv4 or IPv6 address family and enters address family configuration submode.

Step 4 `maximum-paths ibgp number`

Example:

```
RP/0/RP0/CPU0:router(config-bgp-af)# maximum-paths ibgp 30
```

Configures the maximum number of iBGP paths for load sharing.

Step 5 Use the **commit** or **end** command.

commit —Saves the configuration changes and remains within the configuration session.

end —Prompts user to take one of these actions:

- **Yes** — Saves configuration changes and exits the configuration session.
- **No** —Exits the configuration session without committing the configuration changes.
- **Cancel** —Remains in the configuration session, without committing the configuration changes.

iBGP Multipath Loadsharing Configuration: Example

The following is a sample configuration where 30 paths are used for loadsharing:

```
router bgp 100
  address-family ipv4 multicast
    maximum-paths ibgp 30
  !
  !
end
```

Route Dampening

Route dampening is a BGP feature that minimizes the propagation of flapping routes across an internetwork. A route is considered to be flapping when it is repeatedly available, then unavailable, then available, then unavailable, and so on.

For example, consider a network with three BGP autonomous systems: autonomous system 1, autonomous system 2, and autonomous system 3. Suppose the route to network A in autonomous system 1 flaps (it becomes unavailable). Under circumstances without route dampening, the eBGP neighbor of autonomous system 1 to autonomous system 2 sends a withdraw message to autonomous system 2. The border router in autonomous system 2, in turn, propagates the withdrawal message to autonomous system 3. When the route to network A reappears, autonomous system 1 sends an advertisement message to autonomous system 2, which sends it to autonomous system 3. If the route to network A repeatedly becomes unavailable, then available, many withdrawal and advertisement messages are sent. Route flapping is a problem in an internetwork connected to the Internet, because a route flap in the Internet backbone usually involves many routes.

The route dampening feature minimizes the flapping problem as follows. Suppose again that the route to network A flaps. The router in autonomous system 2 (in which route dampening is enabled) assigns network A a penalty of 1000 and moves it to history state. The router in autonomous system 2 continues to advertise the status of the route to neighbors. The penalties are cumulative. When the route flaps so often that the penalty exceeds a configurable suppression limit, the router stops advertising the route to network A, regardless of how many times it flaps. Thus, the route is dampened.

The penalty placed on network A is decayed until the reuse limit is reached, upon which the route is once again advertised. At half of the reuse limit, the dampening information for the route to network A is removed.



Note No penalty is applied to a BGP peer reset when route dampening is enabled, even though the reset withdraws the route.

Configuring BGP Route Dampening

Perform this task to configure and monitor BGP route dampening.

SUMMARY STEPS

1. **configure**
2. **router bgp** *as-number*
3. **address-family** { **ipv4** | **ipv6** } **unicast**
4. **bgp dampening** [*half-life* [*reuse suppress max-suppress-time*]] | **route-policy** *route-policy-name*]
5. Use the **commit** or **end** command.

DETAILED STEPS

Step 1 **configure**

Example:

```
RP/0/RP0/CPU0:router# configure
```

Enters global configuration mode.

Step 2 **router bgp** *as-number*

Example:

```
RP/0/RP0/CPU0:router(config)# router bgp 120
```

Specifies the autonomous system number and enters the BGP configuration mode, allowing you to configure the BGP routing process.

Step 3 **address-family** { **ipv4** | **ipv6** } **unicast**

Example:

```
RP/0/RP0/CPU0:router(config-bgp)# address-family ipv4 unicast
```

Specifies either the IPv4 or IPv6 address family and enters address family configuration submode.

To see a list of all the possible keywords and arguments for this command, use the CLI help (?).

Step 4 **bgp dampening** [*half-life* [*reuse suppress max-suppress-time*]] | **route-policy** *route-policy-name*]

Example:

```
RP/0/RP0/CPU0:router(config-bgp-af)# bgp dampening 30 1500 10000 120
```

Configures BGP dampening for the specified address family.

Step 5 Use the **commit** or **end** command.

commit —Saves the configuration changes and remains within the configuration session.

end —Prompts user to take one of these actions:

- **Yes** — Saves configuration changes and exits the configuration session.
- **No** —Exits the configuration session without committing the configuration changes.
- **Cancel** —Remains in the configuration session, without committing the configuration changes.

Routing Policy Enforcement

External BGP (eBGP) neighbors must have an inbound and outbound policy configured. If no policy is configured, no routes are accepted from the neighbor, nor are any routes advertised to it. This added security measure ensures that routes cannot accidentally be accepted or advertised in the case of a configuration omission error.



Note This enforcement affects only eBGP neighbors (neighbors in a different autonomous system than this router). For internal BGP (iBGP) neighbors (neighbors in the same autonomous system), all routes are accepted or advertised if there is no policy.

Apply Policy When Updating Routing Table

The table policy feature in BGP allows you to configure traffic index values on routes as they are installed in the global routing table. This feature is enabled using the table-policy command and supports the BGP policy accounting feature. Table policy also provides the ability to drop routes from the RIB based on match criteria. This feature can be useful in certain applications and should be used with caution as it can easily create a routing traffic drop where BGP advertises routes to neighbors that BGP does not install in its global routing table and forwarding table.

Perform this task to apply a routing policy to routes being installed into the routing table.

SUMMARY STEPS

1. **configure**
2. **router bgp** *as-number*
3. **address-family** { *ipv4* | *ipv6* } **unicast**
4. **table-policy** *policy-name*

5. Use the **commit** or **end** command.

DETAILED STEPS

Step 1 **configure**

Example:

```
RP/0/RP0/CPU0:router# configure
```

Enters global configuration mode.

Step 2 **router bgp** *as-number*

Example:

```
RP/0/RP0/CPU0:router(config)# router bgp 120.6
```

Specifies the autonomous system number and enters the BGP configuration mode, allowing you to configure the BGP routing process.

Step 3 **address-family** { **ipv4** | **ipv6** } **unicast**

Example:

```
RP/0/RP0/CPU0:router(config-bgp)# address-family ipv4 unicast
```

Specifies either the IPv4 or IPv6 address family and enters address family configuration submode.

To see a list of all the possible keywords and arguments for this command, use the CLI help (?).

Step 4 **table-policy** *policy-name*

Example:

```
RP/0/RP0/CPU0:router(config-bgp-af)# table-policy tbl-plcy-A
```

Applies the specified policy to routes being installed into the routing table.

Step 5 Use the **commit** or **end** command.

commit —Saves the configuration changes and remains within the configuration session.

end —Prompts user to take one of these actions:

- **Yes** — Saves configuration changes and exits the configuration session.
- **No** —Exits the configuration session without committing the configuration changes.
- **Cancel** —Remains in the configuration session, without committing the configuration changes.

Applying routing policy: Example

In the following example, for an eBGP neighbor, if all routes should be accepted and advertised with no modifications, a simple pass-all policy is configured:

```
RP/0/RP0/CPU0:router(config)# route-policy pass-all
RP/0/RP0/CPU0:router(config-rpl)# pass
RP/0/RP0/CPU0:router(config-rpl)# end-policy
RP/0/RP0/CPU0:router(config)# commit
```

Use the **route-policy (BGP)** command in the neighbor address-family configuration mode to apply the pass-all policy to a neighbor. The following example shows how to allow all IPv4 unicast routes to be received from neighbor 192.168.40.42 and advertise all IPv4 unicast routes back to it:

```
RP/0/RP0/CPU0:router(config)# router bgp 1
RP/0/RP0/CPU0:router(config-bgp)# neighbor 192.168.40.24
RP/0/RP0/CPU0:router(config-bgp-nbr)# remote-as 21
RP/0/RP0/CPU0:router(config-bgp-nbr)# address-family ipv4 unicast
RP/0/RP0/CPU0:router(config-bgp-nbr-af)# route-policy pass-all in
RP/0/RP0/CPU0:router(config-bgp-nbr-af)# route-policy pass-all out
RP/0/RP0/CPU0:router(config-bgp-nbr-af)# commit
```

Use the **show bgp summary** command to display eBGP neighbors that do not have both an inbound and outbound policy for every active address family. In the following example, such eBGP neighbors are indicated in the output with an exclamation (!) mark:

```
RP/0/RP0/CPU0:router# show bgp all all summary

Address Family: IPv4 Unicast
=====

BGP router identifier 10.0.0.1, local AS number 1
BGP generic scan interval 60 secs
BGP main routing table version 41
BGP scan interval 60 secs
BGP is operating in STANDALONE mode.

Process          RecvTblVer    bRIB/RIB    SendTblVer
Speaker          41           41          41

Neighbor        Spk   AS  MsgRcvd  MsgSent   TblVer  InQ  OutQ  Up/Down  St/PfxRcd
10.0.101.1      0     1    919     925      41     0    0  15:15:08  10
10.0.101.2      0     2     0       0        0     0    0  00:00:00  Idle
```

Remotely Triggered Null Route Filtering with RPL Next-hop Discard Configuration

Remotely triggered black hole (RTBH) filtering is a technique that provides the ability to drop undesirable traffic before it enters a protected network. RTBH filtering provides a method for quickly dropping undesirable traffic at the edge of the network, based on either source addresses or destination addresses by forwarding it to a null0 interface. RTBH filtering based on a destination address is commonly known as Destination-based RTBH filtering. Whereas, RTBH filtering based on a source address is known as Source-based RTBH filtering.

RTBH filtering is one of the many techniques in the security toolkit that can be used together to enhance network security in the following ways:

- Effectively mitigate DDoS and worm attacks

- Quarantine all traffic destined for the target under attack
- Enforce blacklist filtering



Note RTBH is not supported in cases such as L3VPN iBGP route over NULL0.



Note On Jericho2 TCAM-based platforms, when you configure a NULL interface, both destination-based RTBH filtering (D-RTBH) and source-based RTBH filtering (S-RTBH) are triggered.

Configuring Destination-based RTBH Filtering

RTBH is implemented by defining a route policy (RPL) to discard undesirable traffic at next-hop using **set next-hop discard** command.

RTBH filtering sets the next-hop of the victim's prefix to the null interface. The traffic destined to the victim is dropped at the ingress.

The **set next-hop discard** configuration is used in the neighbor inbound policy. When this config is applied to a path, though the primary next-hop is associated with the actual path but the RIB is updated with next-hop set to Null0. Even if the primary received next-hop is unreachable, the RTBH path is considered reachable and will be a candidate in the bestpath selection process. The RTBH path is readvertised to other peers with either the received next-hop or nexthop-self based on normal BGP advertisement rules.

A typical deployment scenario for RTBH filtering would require running internal Border Gateway Protocol (iBGP) at the access and aggregation points and configuring a separate device in the network operations center (NOC) to act as a trigger. The triggering device sends iBGP updates to the edge, that cause undesirable traffic to be forwarded to a null0 interface and dropped.

Consider below topology, where a rogue router is sending traffic to a border router.

Figure 1: Topology to Implement RTBH Filtering

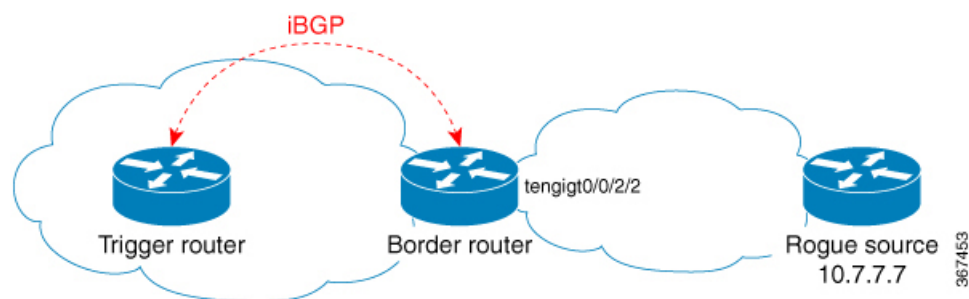

Configurations applied on the Trigger Router

Configure a static route redistribution policy that sets a community on static routes marked with a special tag, and apply it in BGP:

```
route-policy RTBH-trigger
  if tag is 777 then
    set community (1234:4321, no-export) additive
  pass
```



```

else
  pass
endif
end-policy

router bgp 65001
address-family ipv4 unicast
  redistribute static route-policy RTBH-trigger
!
neighbor 192.168.102.1
  remote-as 65001
  address-family ipv4 unicast
  route-policy bgp_all in
  route-policy bgp_all out

```

Configure a static route with the special tag for the source prefix that has to be block-holed:

```

router static
address-family ipv4 unicast
10.7.7.7/32 Null0 tag 777

```

Configurations applied on the Border Router

Configure a route policy that matches the community set on the trigger router and configure set next-hop discard:

```

route-policy RTBH
  if community matches-any (1234:4321) then
    set next-hop discard
  else
    pass
  endif
end-policy

```

Apply the route policy on the iBGP peers:

```

router bgp 65001
address-family ipv4 unicast
!
neighbor 192.168.102.2
  remote-as 65001
  address-family ipv4 unicast
  route-policy RTBH in
  route-policy bgp_all out

```

Verification

On the border router, the prefix 10.7.7.7/32 is flagged as Nexthop-discard:

```

RP/0/RSP0/CPU0:router#show bgp
BGP router identifier 10.210.0.5, local AS number 65001
BGP generic scan interval 60 secs
BGP table state: Active
Table ID: 0xe0000000 RD version: 12
BGP main routing table version 12
BGP scan interval 60 secs

Status codes: s suppressed, d damped, h history, * valid, > best
               i - internal, r RIB-failure, S stale, N Nexthop-discard
Origin codes: i - IGP, e - EGP, ? - incomplete

```

```

Network          Next Hop          Metric LocPrf Weight Path
N>i10.7.7.7/32   192.168.102.2    0      100     0 ?

RP/0/RSP0/CPU0:router#show bgp 10.7.7.7/32
BGP routing table entry for 10.7.7.7/32
Versions:
  Process          bRIB/RIB  SendTblVer
  Speaker          12        12
Last Modified: Jul  4 14:37:29.048 for 00:20:52
Paths: (1 available, best #1, not advertised to EBGp peer)
  Not advertised to any peer
  Path #1: Received by speaker 0
  Not advertised to any peer
Local
  192.168.102.2 (discarded) from 192.168.102.2 (10.210.0.2)
  Origin incomplete, metric 0, localpref 100, valid, internal best, group-best
  Received Path ID 0, Local Path ID 1, version 12
  Community: 1234:4321 no-export

RP/0/RSP0/CPU0:router#show route 10.7.7.7/32

Routing entry for 10.7.7.7/32
  Known via "bgp 65001", distance 200, metric 0, type internal
  Installed Jul  4 14:37:29.394 for 01:47:02
  Routing Descriptor Blocks
    directly connected, via Null0
    Route metric is 0
  No advertising protos.

```

Configure BGP Neighbor Group and Neighbors

Perform this task to configure BGP neighbor groups and apply the neighbor group configuration to a neighbor. A neighbor group is a template that holds address family-independent and address family-dependent configurations that are associated with the neighbor.

After a neighbor group is configured, each neighbor can inherit the configuration through the **use** command. If a neighbor is configured to use a neighbor group, the neighbor (by default) inherits the entire configuration of the neighbor group, which includes the address family-independent and address family-dependent configurations. The inherited configuration can be overridden if you directly configure commands for the neighbor or configure session groups or address family groups through the **use** command.

You can configure an address family-independent configuration under the neighbor group. An address family-dependent configuration requires you to configure the address family under the neighbor group to enter address family submode. From neighbor group configuration mode, you can configure address family-independent parameters for the neighbor group. Use the **address-family** command when in the neighbor group configuration mode. After specifying the neighbor group name using the **neighbor group** command, you can assign options to the neighbor group.



Note All commands that can be configured under a specified neighbor group can be configured under a neighbor.



Note In Cisco IOS-XR versions prior to 6.3.2, you cannot remove an autonomous system that belongs to a BGP neighbor and move it under a BGP neighbor group using a single IOS-XR commit. Effective with 6.3.2, you can move the autonomous system from a neighbor to a neighbor group in a single IOS-XR commit.

SUMMARY STEPS

1. **configure**
2. **router bgp** *as-number*
3. **address-family** { **ipv4** | **ipv6** } **unicast**
4. **exit**
5. **neighbor-group** *name*
6. **remote-as** *as-number*
7. **address-family** { **ipv4** | **ipv6** } **unicast**
8. **route-policy** *route-policy-name* { **in** | **out** }
9. **exit**
10. **exit**
11. **neighbor** *ip-address*
12. **use neighbor-group** *group-name*
13. **remote-as** *as-number*
14. Use the **commit** or **end** command.

DETAILED STEPS

Step 1 **configure**

Example:

```
RP/0/RP0/CPU0:router# configure
```

Enters global configuration mode.

Step 2 **router bgp** *as-number*

Example:

```
RP/0/RP0/CPU0:router(config)# router bgp 120
```

Specifies the autonomous system number and enters the BGP configuration mode, allowing you to configure the BGP routing process.

Step 3 **address-family** { **ipv4** | **ipv6** } **unicast**

Example:

```
RP/0/RP0/CPU0:router(config-bgp)# address-family ipv4 unicast
```

Specifies either an IPv4 or IPv6 address family unicast and enters address family configuration submode.

To see a list of all the possible keywords and arguments for this command, use the CLI help (?).

Step 4 **exit**

Example:

```
RP/0/RP0/CPU0:router(config-bgp-af)# exit
```

Exits the current configuration mode.

Step 5 `neighbor-group name`**Example:**

```
RP/0/RP0/CPU0:router(config-bgp)# neighbor-group nbr-grp-A
```

Places the router in neighbor group configuration mode.

Step 6 `remote-as as-number`**Example:**

```
RP/0/RP0/CPU0:router(config-bgp-nbrgrp)# remote-as 2002
```

Creates a neighbor and assigns a remote autonomous system number to it.

Step 7 `address-family { ipv4 | ipv6 } unicast`**Example:**

```
RP/0/RP0/CPU0:router(config-bgp-nbrgrp)# address-family ipv4 unicast
```

Specifies either an IPv4 or IPv6 address family unicast and enters address family configuration submode.

To see a list of all the possible keywords and arguments for this command, use the CLI help (?).

Step 8 `route-policy route-policy-name { in | out }`**Example:**

```
RP/0/RP0/CPU0:router(config-bgp-nbrgrp-af)# route-policy drop-as-1234 in
```

(Optional) Applies the specified policy to inbound IPv4 unicast routes.

Step 9 `exit`**Example:**

```
RP/0/RP0/CPU0:router(config-bgp-nbrgrp-af)# exit
```

Exits the current configuration mode.

Step 10 `exit`**Example:**

```
RP/0/RP0/CPU0:router(config-bgp-nbrgrp)# exit
```

Exits the current configuration mode.

Step 11 `neighbor ip-address`**Example:**

```
RP/0/RP0/CPU0:router(config-bgp)# neighbor 172.168.40.24
```

Places the router in neighbor configuration mode for BGP routing and configures the neighbor IP address as a BGP peer.

Step 12 `use neighbor-group group-name`

Example:

```
RP/0/RP0/CPU0:router(config-bgp-nbr)# use neighbor-group nbr-grp-A
```

(Optional) Specifies that the BGP neighbor inherit configuration from the specified neighbor group.

Step 13 **remote-as** *as-number***Example:**

```
RP/0/RP0/CPU0:router(config-bgp-nbr)# remote-as 2002
```

Creates a neighbor and assigns a remote autonomous system number to it.

Step 14 Use the **commit** or **end** command.

commit —Saves the configuration changes and remains within the configuration session.

end —Prompts user to take one of these actions:

- **Yes** — Saves configuration changes and exits the configuration session.
- **No** —Exits the configuration session without committing the configuration changes.
- **Cancel** —Remains in the configuration session, without committing the configuration changes.

BGP Neighbor Configuration: Example

The following example shows how BGP neighbors on an autonomous system are configured to share information. In the example, a BGP router is assigned to autonomous system 109, and two networks are listed as originating in the autonomous system. Then the addresses of three remote routers (and their autonomous systems) are listed. The router being configured shares information about networks 172.16.0.0 and 192.168.7.0 with the neighbor routers. The first router listed is in a different autonomous system; the second **neighbor** and **remote-as** commands specify an internal neighbor (with the same autonomous system number) at address 172.26.234.2; and the third **neighbor** and **remote-as** commands specify a neighbor on a different autonomous system.

```
route-policy pass-all
  pass
end-policy
router bgp 109
  address-family ipv4 unicast
    network 172.16.0.0 255.255.0.0
    network 192.168.7.0 255.255.0.0
    neighbor 172.16.200.1
      remote-as 167

  address-family ipv4 unicast
    route-policy pass-all in
    route-policy pass-out out
    neighbor 172.26.234.2
      remote-as 109

  address-family ipv4 unicast
    neighbor 172.26.64.19
      remote-as 99
```

```
address-family ipv4 unicast
route-policy pass-all in
route-policy pass-all out
```

Disable BGP Neighbor

Perform this task to administratively shut down a neighbor session without removing the configuration.

SUMMARY STEPS

1. **configure**
2. **router bgp** *as-number*
3. **neighbor** *ip-address*
4. **shutdown**
5. Use the **commit** or **end** command.

DETAILED STEPS

Step 1 **configure**

Example:

```
RP/0/RP0/CPU0:router# configure
```

Enters global configuration mode.

Step 2 **router bgp** *as-number*

Example:

```
RP/0/RP0/CPU0:router(config)# router bgp 127
```

Specifies the autonomous system number and enters the BGP configuration mode, allowing you to configure the BGP routing process.

Step 3 **neighbor** *ip-address*

Example:

```
RP/0/RP0/CPU0:router(config-bgp)# neighbor 172.168.40.24
```

Places the router in neighbor configuration mode for BGP routing and configures the neighbor IP address as a BGP peer.

Step 4 **shutdown**

Example:

```
RP/0/RP0/CPU0:router(config-bgp-nbr)# shutdown
```

Disables all active sessions for the specified neighbor.

Step 5 Use the **commit** or **end** command.

commit —Saves the configuration changes and remains within the configuration session.

end —Prompts user to take one of these actions:

- **Yes** — Saves configuration changes and exits the configuration session.
- **No** —Exits the configuration session without committing the configuration changes.
- **Cancel** —Remains in the configuration session, without committing the configuration changes.

Resetting Neighbors Using BGP Inbound Soft Reset

Perform this task to trigger an inbound soft reset of the specified address families for the specified group or neighbors. The group is specified by the *****, *ip-address*, *as-number*, or **external** keywords and arguments.

Resetting neighbors is useful if you change the inbound policy for the neighbors or any other configuration that affects the sending or receiving of routing updates. If an inbound soft reset is triggered, BGP sends a REFRESH request to the neighbor if the neighbor has advertised the ROUTE_REFRESH capability. To determine whether the neighbor has advertised the ROUTE_REFRESH capability, use the **show bgp neighbors** command.

SUMMARY STEPS

1. **show bgp neighbors**
2. **soft [in [prefix-filter] | out]**

DETAILED STEPS

	Command or Action	Purpose
Step 1	show bgp neighbors Example: RP/0/RP0/CPU0:router# show bgp neighbors	Verifies that received route refresh capability from the neighbor is enabled.
Step 2	soft [in [prefix-filter] out] Example: RP/0/RP0/CPU0:router# clear bgp ipv4 unicast 10.0.0.1 soft in	Soft resets a BGP neighbor. <ul style="list-style-type: none"> • The * keyword resets all BGP neighbors. • The <i>ip-address</i> argument specifies the address of the neighbor to be reset. • The <i>as-number</i> argument specifies that all neighbors that match the autonomous system number be reset. • The external keyword specifies that all external neighbors are reset.

Resetting Neighbors Using BGP Outbound Soft Reset

Perform this task to trigger an outbound soft reset of the specified address families for the specified group or neighbors. The group is specified by the *****, *ip-address*, *as-number*, or **external** keywords and arguments.

Resetting neighbors is useful if you change the outbound policy for the neighbors or any other configuration that affects the sending or receiving of routing updates.

If an outbound soft reset is triggered, BGP resends all routes for the address family to the given neighbors.

To determine whether the neighbor has advertised the ROUTE_REFRESH capability, use the **show bgp neighbors** command.

SUMMARY STEPS

1. **show bgp neighbors**
- 2.

DETAILED STEPS

	Command or Action	Purpose
Step 1	show bgp neighbors Example: RP/0/RP0/CPU0:router# show bgp neighbors	Verifies that received route refresh capability from the neighbor is enabled.
Step 2	Example: RP/0/RP0/CPU0:router# clear bgp ipv4 unicast 10.0.0.2 soft out	Soft resets a BGP neighbor. <ul style="list-style-type: none"> • The * keyword resets all BGP neighbors. • The <i>ip-address</i> argument specifies the address of the neighbor to be reset. • The <i>as-number</i> argument specifies that all neighbors that match the autonomous system number be reset. • The external keyword specifies that all external neighbors are reset.

Reset Neighbors Using BGP Hard Reset

Perform this task to reset neighbors using a hard reset. A hard reset removes the TCP connection to the neighbor, removes all routes received from the neighbor from the BGP table, and then re-establishes the session with the neighbor. If the **graceful** keyword is specified, the routes from the neighbor are not removed from the BGP table immediately, but are marked as stale. After the session is re-established, any stale route that has not been received again from the neighbor is removed.

SUMMARY STEPS

1. **clear bgp { ipv4 { unicast | labeled-unicast | all | tunnel tunnel | mdt } | ipv6 unicast | all | labeled-unicast } | all { unicast | multicast | all | labeled-unicast | mdt | tunnel } | vpv4 unicast | vrf { vrf-name | all } { ipv4 unicast | labeled-unicast } | ipv6 unicast } | vpv6 unicast } { * | ip-address | as as-number | external } [graceful] soft [in [prefix-filter] | out] clear bgp { ipv4 | ipv6 } { unicast | labeled-unicast }**

DETAILED STEPS

```
clear bgp { ipv4 { unicast | labeled-unicast | all | tunnel tunnel | mdt } | ipv6 unicast | all | labeled-unicast
} | all { unicast | multicast | all | labeled-unicast | mdt | tunnel } | vpnv4 unicast | vrf { vrf-name | all } {
ipv4 unicast | labeled-unicast } | ipv6 unicast } | vpnv6 unicast } { * | ip-address | as as-number | external
} [ graceful ] soft [ in [ prefix-filter ] | out ] clear bgp { ipv4 | ipv6 } { unicast | labeled-unicast }
```

Example:

```
RP/0/RP0/CPU0:router# clear bgp ipv4 unicast 10.0.0.3
```

Clears a BGP neighbor.

- The `*` keyword resets all BGP neighbors.
- The `ip-address` argument specifies the address of the neighbor to be reset.
- The `as-number` argument specifies that all neighbors that match the autonomous system number be reset.
- The `external` keyword specifies that all external neighbors are reset.

The `graceful` keyword specifies a graceful restart.

Configure Software to Store Updates from Neighbor

Perform this task to configure the software to store updates received from a neighbor.

The `soft-reconfiguration inbound` command causes a route refresh request to be sent to the neighbor if the neighbor is route refresh capable. If the neighbor is not route refresh capable, the neighbor must be reset to relearn received routes using the `clear bgp soft` command.



Note Storing updates from a neighbor works only if either the neighbor is route refresh capable or the `soft-reconfiguration inbound` command is configured. Even if the neighbor is route refresh capable and the `soft-reconfiguration inbound` command is configured, the original routes are not stored unless the `always` option is used with the command. The original routes can be easily retrieved with a route refresh request. Route refresh sends a request to the peer to resend its routing information. The `soft-reconfiguration inbound` command stores all paths received from the peer in an unmodified form and refers to these stored paths during the clear. Soft reconfiguration is memory intensive.

SUMMARY STEPS

1. `configure`
2. `router bgp as-number`
3. `neighbor ip-address`
4. `address-family { ipv4 | ipv6 } unicast`
5. `soft-reconfiguration inbound [always]`
6. Use the `commit` or `end` command.

DETAILED STEPS

Step 1 **configure**

Example:

```
RP/0/RP0/CPU0:router# configure
```

Enters global configuration mode.

Step 2 **router bgp** *as-number*

Example:

```
RP/0/RP0/CPU0:router(config)# router bgp 120
```

Specifies the autonomous system number and enters the BGP configuration mode, allowing you to configure the BGP routing process.

Step 3 **neighbor** *ip-address*

Example:

```
RP/0/RP0/CPU0:router(config-bgp)# neighbor 172.168.40.24
```

Places the router in neighbor configuration mode for BGP routing and configures the neighbor IP address as a BGP peer.

Step 4 **address-family** { **ipv4** | **ipv6** } **unicast**

Example:

```
RP/0/RP0/CPU0:router(config-bgp-nbr)# address-family ipv4 unicast
```

Specifies either an IPv4 or IPv6 address family unicast and enters address family configuration submode.

To see a list of all the possible keywords and arguments for this command, use the CLI help (?).

Step 5 **soft-reconfiguration inbound** [**always**]

Example:

```
RP/0/RP0/CPU0:router(config-bgp-nbr-af)# soft-reconfiguration inbound always
```

Configures the software to store updates received from a specified neighbor. Soft reconfiguration inbound causes the software to store the original unmodified route in addition to a route that is modified or filtered. This allows a “soft clear” to be performed after the inbound policy is changed.

Soft reconfiguration enables the software to store the incoming updates before apply policy if route refresh is not supported by the peer (otherwise a copy of the update is not stored). The **always** keyword forces the software to store a copy even when route refresh is supported by the peer.

Step 6 Use the **commit** or **end** command.

commit —Saves the configuration changes and remains within the configuration session.

end —Prompts user to take one of these actions:

- **Yes** — Saves configuration changes and exits the configuration session.
- **No** —Exits the configuration session without committing the configuration changes.

- **Cancel**—Remains in the configuration session, without committing the configuration changes.

Log Neighbor Changes

Logging neighbor changes is enabled by default. Use the **bgp log neighbor changes disable** command to turn off logging. Use the **no bgp log neighbor changes disable** command to turn logging back on, if it has been disabled.

BGP Route Reflectors

BGP requires that all iBGP speakers be fully meshed. However, this requirement does not scale well when there are many iBGP speakers. Instead of configuring a confederation, you can reduce the iBGP mesh by using a route reflector configuration. With route reflectors, all iBGP speakers need not be fully meshed because there is a method to pass learned routes to neighbors. In this model, an iBGP peer is configured to be a route reflector responsible for passing iBGP learned routes to a set of iBGP neighbors.

In [#unique_83 unique_83_Connect_42_fig_3980C23832D84D43BB58222F040E5A96](#), Router B is configured as a route reflector. When the route reflector receives routes advertised from Router A, it advertises them to Router C, and vice versa. This scheme eliminates the need for the iBGP session between routers A and C.

See [BGP Route Reflectors Reference, on page 23](#) for additional details on route reflectors.

Configure Route Reflector for BGP

Perform this task to configure a route reflector for BGP.

All the neighbors configured with the **route-reflector-client** command are members of the client group, and the remaining iBGP peers are members of the nonclient group for the local route reflector.

Together, a route reflector and its clients form a *cluster*. A cluster of clients usually has a single route reflector. In such instances, the cluster is identified by the software as the router ID of the route reflector. To increase redundancy and avoid a single point of failure in the network, a cluster can have more than one route reflector. If it does, all route reflectors in the cluster must be configured with the same 4-byte cluster ID so that a route reflector can recognize updates from route reflectors in the same cluster. The **bgp cluster-id** command is used to configure the cluster ID when the cluster has more than one route reflector.

SUMMARY STEPS

1. **configure**
2. **router bgp** *as-number*
3. **bgp cluster-id** *cluster-id*
4. **neighbor** *ip-address*
5. **remote-as** *as-number*
6. **address-family** { **ipv4** | **ipv6** } **unicast**
7. **route-reflector-client**
8. Use the **commit** or **end** command.

DETAILED STEPS

Step 1 **configure****Example:**

```
RP/0/RP0/CPU0:router# configure
```

Enters global configuration mode.

Step 2 **router bgp** *as-number***Example:**

```
RP/0/RP0/CPU0:router(config)# router bgp 120
```

Specifies the autonomous system number and enters the BGP configuration mode, allowing you to configure the BGP routing process.

Step 3 **bgp cluster-id** *cluster-id***Example:**

```
RP/0/RP0/CPU0:router(config-bgp)# bgp cluster-id 192.168.70.1
```

Configures the local router as one of the route reflectors serving the cluster. It is configured with a specified cluster ID to identify the cluster.

Step 4 **neighbor** *ip-address***Example:**

```
RP/0/RP0/CPU0:router(config-bgp)# neighbor 172.168.40.24
```

Places the router in neighbor configuration mode for BGP routing and configures the neighbor IP address as a BGP peer.

Step 5 **remote-as** *as-number***Example:**

```
RP/0/RP0/CPU0:router(config-bgp-nbr)# remote-as 2003
```

Creates a neighbor and assigns a remote autonomous system number to it.

Step 6 **address-family** { **ipv4** | **ipv6** } **unicast****Example:**

```
RP/0/RP0/CPU0:router(config-nbr)# address-family ipv4 unicast
```

Specifies either an IPv4 or IPv6 address family unicast and enters address family configuration submode.

To see a list of all the possible keywords and arguments for this command, use the CLI help (?).

Step 7 **route-reflector-client****Example:**

```
RP/0/RP0/CPU0:router(config-bgp-nbr-af)# route-reflector-client
```

Configures the router as a BGP route reflector and configures the neighbor as its client.

Step 8 Use the **commit** or **end** command.

commit —Saves the configuration changes and remains within the configuration session.

end —Prompts user to take one of these actions:

- **Yes** — Saves configuration changes and exits the configuration session.
- **No** —Exits the configuration session without committing the configuration changes.
- **Cancel** —Remains in the configuration session, without committing the configuration changes.

BGP Route Reflector: Example

The following example shows how to use an address family to configure internal BGP peer 10.1.1.1 as a route reflector client for unicast prefixes:

```
router bgp 140
 address-family ipv4 unicast
  neighbor 10.1.1.1
  remote-as 140
 address-family ipv4 unicast
  route-reflector-client
 exit
```

Configure BGP Route Filtering by Route Policy

Perform this task to configure BGP routing filtering by route policy.

SUMMARY STEPS

1. **configure**
2. **route-policy** *name*
3. **end-policy**
4. **router bgp** *as-number*
5. **neighbor** *ip-address*
6. **address-family** { **ipv4** | **ipv6** } **unicast**
7. **route-policy** *route-policy-name* { **in** | **out** }
8. Use the **commit** or **end** command.

DETAILED STEPS

	Command or Action	Purpose
Step 1	configure Example: RP/0/RP0/CPU0:router# configure	Enters global configuration mode.
Step 2	route-policy name Example: RP/0/RP0/CPU0:router(config)# route-policy drop-as-1234 RP/0/RP0/CPU0:router(config-rpl)# if as-path passes-through '1234' then RP/0/RP0/CPU0:router(config-rpl)# apply check-communities RP/0/RP0/CPU0:router(config-rpl)# else RP/0/RP0/CPU0:router(config-rpl)# pass RP/0/RP0/CPU0:router(config-rpl)# endif	(Optional) Creates a route policy and enters route policy configuration mode, where you can define the route policy.
Step 3	end-policy Example: RP/0/RP0/CPU0:router(config-rpl)# end-policy	(Optional) Ends the definition of a route policy and exits route policy configuration mode.
Step 4	router bgp as-number Example: RP/0/RP0/CPU0:router(config)# router bgp 120	Specifies the autonomous system number and enters the BGP configuration mode, allowing you to configure the BGP routing process.
Step 5	neighbor ip-address Example: RP/0/RP0/CPU0:router(config-bgp)# neighbor 172.168.40.24	Places the router in neighbor configuration mode for BGP routing and configures the neighbor IP address as a BGP peer.
Step 6	address-family { ipv4 ipv6 } unicast Example: RP/0/RP0/CPU0:router(config-bgp-nbr)# address-family ipv4 unicast	Specifies either an IPv4 or IPv6 address family unicast and enters address family configuration submode. To see a list of all the possible keywords and arguments for this command, use the CLI help (?).
Step 7	route-policy route-policy-name { in out } Example: RP/0/RP0/CPU0:router(config-bgp-nbr-af)# route-policy drop-as-1234 in	Applies the specified policy to inbound routes.
Step 8	Use the commit or end command.	commit —Saves the configuration changes and remains within the configuration session.

	Command or Action	Purpose
		<p>end —Prompts user to take one of these actions:</p> <ul style="list-style-type: none"> • Yes — Saves configuration changes and exits the configuration session. • No —Exits the configuration session without committing the configuration changes. • Cancel —Remains in the configuration session, without committing the configuration changes.

Configure BGP Attribute Filtering

The BGP Attribute Filter checks integrity of BGP updates in BGP update messages and optimizes reaction when detecting invalid attributes. BGP Update message contains a list of mandatory and optional attributes. These attributes in the update message include MED, LOCAL_PREF, COMMUNITY, and so on. In some cases, if the attributes are malformed, there is a need to filter these attributes at the receiving end of the router. The BGP Attribute Filter functionality filters the attributes received in the incoming update message. The attribute filter can also be used to filter any attributes that may potentially cause undesirable behavior on the receiving router. Some of the BGP updates are malformed due to wrong formatting of attributes such as the network layer reachability information (NLRI) or other fields in the update message. These malformed updates, when received, causes undesirable behavior on the receiving routers. Such undesirable behavior may be encountered during update message parsing or during re-advertisement of received NLRIs. In such scenarios, its better to filter these corrupted attributes at the receiving end.

The Attribute-filtering is configured by specifying a single or a range of attribute codes and an associated action. When a received Update message contains one or more filtered attributes, the configured action is applied on the message. Optionally, the Update message is also stored to facilitate further debugging and a syslog message is generated on the console. When an attribute matches the filter, further processing of the attribute is stopped and the corresponding action is taken. Perform the following tasks to configure BGP attribute filtering:

SUMMARY STEPS

1. **configure**
2. **router bgp** *as-number*
3. **attribute-filter group** *attribute-filter group name*
4. **attribute** *attribute code* { **discard** | **treat-as-withdraw** }

DETAILED STEPS

Step 1 **configure**

Example:

```
RP/0/RP0/CPU0:router# configure
```

Enters global configuration mode.

Step 2 **router bgp** *as-number*

Example:

```
RP/0/RP0/CPU0:router(config)# router bgp 100
```

Specifies the autonomous system number and enters the BGP configuration mode, allowing you to configure the BGP routing process.

Step 3 **attribute-filter group** *attribute-filter group name***Example:**

```
RP/0/RP0/CPU0:router(config-bgp)# attribute-filter group ag_discard_med
```

Specifies the attribute-filter group name and enters the attribute-filter group configuration mode, allowing you to configure a specific attribute filter group for a BGP neighbor.

Step 4 **attribute** *attribute code* { **discard** | **treat-as-withdraw** }**Example:**

```
RP/0/RP0/CPU0:router(config-bgp-attrfg)# attribute 24 discard
```

Specifies a single or a range of attribute codes and an associated action. The allowed actions are:

- **Treat-as-withdraw**— Considers the update message for withdrawal. The associated IPv4-unicast or MP_REACH NLRIs, if present, are withdrawn from the neighbor's Adj-RIB-In.
- **Discard Attribute**— Discards this attribute. The matching attributes alone are discarded and the rest of the Update message is processed normally.

BGP Next Hop Tracking

BGP receives notifications from the Routing Information Base (RIB) when next-hop information changes (event-driven notifications). BGP obtains next-hop information from the RIB to:

- Determine whether a next hop is reachable.
- Find the fully recursed IGP metric to the next hop (used in the best-path calculation).
- Validate the received next hops.
- Calculate the outgoing next hops.
- Verify the reachability and connectedness of neighbors.

[BGP Next Hop Reference](#), on page 19 provides additional conceptual details on BGP next hop.

Configure BGP Next-Hop Trigger Delay

Perform this task to configure BGP next-hop trigger delay. The Routing Information Base (RIB) classifies the dampening notifications based on the severity of the changes. Event notifications are classified as critical and noncritical. This task allows you to specify the minimum batching interval for the critical and noncritical events.

SUMMARY STEPS

1. **configure**
2. **router bgp** *as-number*
3. **address-family** { **ipv4** | **ipv6** } **unicast**
4. **nexthop trigger-delay** { **critical** *delay* | **non-critical** *delay* }
5. Use the **commit** or **end** command.

DETAILED STEPS

Step 1 **configure**

Example:

```
RP/0/RP0/CPU0:router# configure
```

Enters global configuration mode.

Step 2 **router bgp** *as-number*

Example:

```
RP/0/RP0/CPU0:router(config)# router bgp 120
```

Specifies the autonomous system number and enters the BGP configuration mode, allowing you to configure the BGP routing process.

Step 3 **address-family** { **ipv4** | **ipv6** } **unicast**

Example:

```
RP/0/RP0/CPU0:router(config-bgp)# address-family ipv4 unicast
```

Specifies either an IPv4 or IPv6 address family unicast and enters address family configuration submode.

To see a list of all the possible keywords and arguments for this command, use the CLI help (?).

Step 4 **nexthop trigger-delay** { **critical** *delay* | **non-critical** *delay* }

Example:

```
RP/0/RP0/CPU0:router(config-bgp-af)# nexthop trigger-delay critical 15000
```

Sets the critical next-hop trigger delay.

Step 5 Use the **commit** or **end** command.

commit —Saves the configuration changes and remains within the configuration session.

end —Prompts user to take one of these actions:

- **Yes** — Saves configuration changes and exits the configuration session.
- **No** —Exits the configuration session without committing the configuration changes.

- **Cancel** —Remains in the configuration session, without committing the configuration changes.

Disable Next-Hop Processing on BGP Updates

Perform this task to disable next-hop calculation for a neighbor and insert your own address in the next-hop field of BGP updates. Disabling the calculation of the best next hop to use when advertising a route causes all routes to be advertised with the network device as the next hop.



Note Next-hop processing can be disabled for address family group, neighbor group, or neighbor address family.

SUMMARY STEPS

1. **configure**
2. **router bgp** *as-number*
3. **neighbor** *ip-address*
4. **remote-as** *as-number*
5. **address-family** { **ipv4** | **ipv6** } **unicast**
6. **next-hop-self**
7. Use the **commit** or **end** command.

DETAILED STEPS

Step 1 **configure**

Example:

```
RP/0/RP0/CPU0:router# configure
```

Enters global configuration mode.

Step 2 **router bgp** *as-number*

Example:

```
RP/0/RP0/CPU0:router(config)# router bgp 120
```

Specifies the autonomous system number and enters the BGP configuration mode, allowing you to configure the BGP routing process.

Step 3 **neighbor** *ip-address*

Example:

```
RP/0/RP0/CPU0:router(config-bgp)# neighbor 172.168.40.24
```

Places the router in neighbor configuration mode for BGP routing and configures the neighbor IP address as a BGP peer.

Step 4 **remote-as** *as-number*

Example:

```
RP/0/RP0/CPU0:router(config-bgp-nbr)# remote-as 206
```

Creates a neighbor and assigns a remote autonomous system number to it.

Step 5 **address-family { ipv4 | ipv6 } unicast****Example:**

```
RP/0/RP0/CPU0:router(config-bgp-nbr)# address-family ipv4 unicast
```

Specifies either an IPv4 or IPv6 address family unicast and enters address family configuration submode.

To see a list of all the possible keywords and arguments for this command, use the CLI help (?).

Step 6 **next-hop-self****Example:**

```
RP/0/RP0/CPU0:router(config-bgp-nbr-af)# next-hop-self
```

Sets the next-hop attribute for all routes advertised to the specified neighbor to the address of the local router. Disabling the calculation of the best next hop to use when advertising a route causes all routes to be advertised with the local network device as the next hop.

Step 7 Use the **commit** or **end** command.

commit —Saves the configuration changes and remains within the configuration session.

end —Prompts user to take one of these actions:

- **Yes** — Saves configuration changes and exits the configuration session.
- **No** —Exits the configuration session without committing the configuration changes.
- **Cancel** —Remains in the configuration session, without committing the configuration changes.

BGP Cost Community

The BGP cost community is a nontransitive extended community attribute that is passed to internal BGP (iBGP) and confederation peers but not to external BGP (eBGP) peers. The cost community feature allows you to customize the local route preference and influence the best-path selection process by assigning cost values to specific routes. The extended community format defines generic points of insertion (POI) that influence the best-path decision at different points in the best-path algorithm.

[BGP Cost Community Reference, on page 19](#) provides additional conceptual details on BGP cost community.

Configure BGP Cost Community

BGP receives multiple paths to the same destination and it uses the best-path algorithm to decide which is the best path to install in RIB. To enable users to determine an exit point after partial comparison, the cost community is defined to tie-break equal paths during the best-path selection process. Perform this task to configure the BGP cost community.

SUMMARY STEPS

1. **configure**
2. **route-policy** *name*
3. **set extcommunity cost** { *cost-extcommunity-set-name* | *cost-inline-extcommunity-set* } [**additive**]
4. **end-policy**
5. **router bgp** *as-number*
6. Do one of the following:
 - **default-information originate**
 - **aggregate-address** *address/mask-length* [**as-set**] [**as-confed-set**] [**summary-only**] [**route-policy** *route-policy-name*]
 - **redistribute connected** [**metric** *metric-value*] [**route-policy** *route-policy-name*]
 - *process-id* [**match** { **external** | **internal** }] [**metric** *metric-value*] [**route-policy** *route-policy-name*]
 - **redistribute isis** *process-id* [**level** { **1** | **1-inter-area** | **2** }] [**metric** *metric-value*] [**route-policy** *route-policy-name*]
 - **redistribute ospf** *process-id* [**match** { **external** [**1** | **2**] | **internal** | **nssa-external** [**1** | **2**] }] [**metric** *metric-value*] [**route-policy** *route-policy-name*]
7. Do one of the following:
 - **redistribute ospfv3** *process-id* [**match** { **external** [**1** | **2**] | **internal** | **nssa-external** [**1** | **2**] }] [**metric** *metric-value*] [**route-policy** *route-policy-name*]
 - **redistribute rip** [**metric** *metric-value*] [**route-policy** *route-policy-name*]
 - **redistribute static** [**metric** *metric-value*] [**route-policy** *route-policy-name*]
 - **network** { *ip-address/prefix-length* | *ip-address mask* } [**route-policy** *route-policy-name*]
 - **neighbor** *ip-address* **remote-as** *as-number*
 - **route-policy** *route-policy-name* { **in** | **out** }
8. Use the **commit** or **end** command.
9. **show bgp** *ip-address*

DETAILED STEPS

Step 1 **configure****Example:**

```
RP/0/RP0/CPU0:router# configure
```

Enters global configuration mode.

Step 2 **route-policy** *name***Example:**

```
RP/0/RP0/CPU0:router(config)# route-policy costA
```

Enters route policy configuration mode and specifies the name of the route policy to be configured.

Step 3 **set extcommunity cost** { *cost-extcommunity-set-name* | *cost-inline-extcommunity-set* } [**additive**]

Example:

```
RP/0/RP0/CPU0:router(config)# set extcommunity cost cost_A
```

Specifies the BGP extended community attribute for cost.

Step 4 end-policy**Example:**

```
RP/0/RP0/CPU0:router(config)# end-policy
```

Ends the definition of a route policy and exits route policy configuration mode.

Step 5 router bgp as-number**Example:**

```
RP/0/RP0/CPU0:router(config)# router bgp 120
```

Enters BGP configuration mode allowing you to configure the BGP routing process.

Step 6 Do one of the following:

- **default-information originate**
- **aggregate-address** *address/mask-length* [**as-set**] [**as-confed-set**] [**summary-only**] [**route-policy** *route-policy-name*]
- **redistribute connected** [**metric** *metric-value*] [**route-policy** *route-policy-name*]
- **process-id** [**match** { **external** | **internal** }] [**metric** *metric-value*] [**route-policy** *route-policy-name*]
- **redistribute isis** *process-id* [**level** { **1** | **1-inter-area** | **2** }] [**metric** *metric-value*] [**route-policy** *route-policy-name*]
- **redistribute ospf** *process-id* [**match** { **external** [**1** | **2**] | **internal** | **nssa-external** [**1** | **2**] }] [**metric** *metric-value*] [**route-policy** *route-policy-name*]

Applies the cost community to the attach point (route policy).

Step 7 Do one of the following:

- **redistribute ospfv3** *process-id* [**match** { **external** [**1** | **2**] | **internal** | **nssa-external** [**1** | **2**] }] [**metric** *metric-value*] [**route-policy** *route-policy-name*]
- **redistribute rip** [**metric** *metric-value*] [**route-policy** *route-policy-name*]
- **redistribute static** [**metric** *metric-value*] [**route-policy** *route-policy-name*]
- **network** { *ip-address/prefix-length* | *ip-address mask* } [**route-policy** *route-policy-name*]
- **neighbor** *ip-address* **remote-as** *as-number*
- **route-policy** *route-policy-name* { **in** | **out** }

Step 8 Use the **commit** or **end** command.

commit —Saves the configuration changes and remains within the configuration session.

end —Prompts user to take one of these actions:

- **Yes** — Saves configuration changes and exits the configuration session.
- **No** —Exits the configuration session without committing the configuration changes.
- **Cancel** —Remains in the configuration session, without committing the configuration changes.

Step 9 `show bgp ip-address`

Example:

```
RP/0/RP0/CPU0:router# show bgp 172.168.40.24
```

Displays the cost community in the following format:

Cost: *POI* : *cost-community-ID* : *cost-number*

Configure BGP Community and Extended-Community Advertisements

Perform this task to specify that community/extended-community attributes should be sent to an eBGP neighbor. These attributes are not sent to an eBGP neighbor by default. By contrast, they are always sent to iBGP neighbors. This section provides examples on how to enable sending community attributes. The **send-community-ebgp** keyword can be replaced by the **send-extended-community-ebgp** keyword to enable sending extended-communities.

If the **send-community-ebgp** command is configured for a neighbor group or address family group, all neighbors using the group inherit the configuration. Configuring the command specifically for a neighbor overrides inherited values.



Note BGP community and extended-community filtering cannot be configured for iBGP neighbors. Communities and extended-communities are always sent to iBGP neighbors under VPNv4, MDT, IPv4, and IPv6 address families.

SUMMARY STEPS

1. **configure**
2. **router bgp** *as-number*
3. **neighbor** *ip-address*
4. **remote-as** *as-number*
5. **address-family** {**ipv4** {**labeled-unicast** | **unicast** | **mdt** | | **mvpn** | **rt-filter** | **tunnel**} | **ipv6** {**labeled-unicast** | **mvpn** | **unicast**}}
6. Use one of these commands:
 - **send-community-ebgp**
 - **send-extended-community-ebgp**
7. Use the **commit** or **end** command.

DETAILED STEPS

Step 1 **configure**

Example:

```
RP/0/RP0/CPU0:router# configure
```

Enters global configuration mode.

Step 2 `router bgp as-number`

Example:

```
RP/0/RP0/CPU0:router(config)# router bgp 120
```

Specifies the autonomous system number and enters the BGP configuration mode, allowing you to configure the BGP routing process.

Step 3 `neighbor ip-address`

Example:

```
RP/0/RP0/CPU0:router(config-bgp)# neighbor 172.168.40.24
```

Places the router in neighbor configuration mode for BGP routing and configures the neighbor IP address as a BGP peer.

Step 4 `remote-as as-number`

Example:

```
RP/0/RP0/CPU0:router(config-bgp-nbr)# remote-as 2002
```

Creates a neighbor and assigns a remote autonomous system number to it.

Step 5 `address-family {ipv4 {labeled-unicast | unicast | mdt | | mvpn | rt-filter | tunnel} | ipv6 {labeled-unicast | mvpn | unicast}}`

Example:

```
RP/0/RP0/CPU0:router(config-bgp-nbr)# address-family ipv6 unicast
```

Enters neighbor address family configuration mode for the specified address family. Use either **ipv4** or **ipv6** address family keyword with one of the specified address family sub mode identifiers.

IPv6 address family mode supports these sub modes:

- **labeled-unicast**
- **mvpn**
- **unicast**

IPv4 address family mode supports these sub modes:

- **labeled-unicast**
- **mdt**
- **mvpn**
- **rt-filter**
- **tunnel**
- **unicast**

Step 6 Use one of these commands:

- **send-community-ebgp**
- **send-extended-community-ebgp**

Example:

```
RP/0/RP0/CPU0:router(config-bgp-nbr-af)# send-community-ebgp
```

or

```
RP/0/RP0/CPU0:router(config-bgp-nbr-af)# send-extended-community-ebgp
```

Specifies that the router send community attributes or extended community attributes (which are disabled by default for eBGP neighbors) to a specified eBGP neighbor.

Step 7 Use the **commit** or **end** command.

commit —Saves the configuration changes and remains within the configuration session.

end —Prompts user to take one of these actions:

- **Yes** — Saves configuration changes and exits the configuration session.
- **No** —Exits the configuration session without committing the configuration changes.
- **Cancel** —Remains in the configuration session, without committing the configuration changes.

Redistribute iBGP Routes into IGP

Perform this task to redistribute iBGP routes into an Interior Gateway Protocol (IGP), such as Intermediate System-to-Intermediate System (IS-IS) or Open Shortest Path First (OSPF).



Note Use of the **bgp redistribute-internal** command requires the **clear route *** command to be issued to reinstall all BGP routes into the IP routing table.



Caution Redistributing iBGP routes into IGP's may cause routing loops to form within an autonomous system. Use this command with caution.

SUMMARY STEPS

1. **configure**
2. **router bgp** *as-number*
3. **bgp redistribute-internal**
4. Use the **commit** or **end** command.

DETAILED STEPS

Step 1 **configure**

Example:

```
RP/0/RP0/CPU0:router# configure
```

Enters global configuration mode.

Step 2 `router bgp as-number`

Example:

```
RP/0/RP0/CPU0:router(config)# router bgp 120
```

Specifies the autonomous system number and enters the BGP configuration mode, allowing you to configure the BGP routing process.

Step 3 `bgp redistribute-internal`

Example:

```
RP/0/RP0/CPU0:router(config-bgp)# bgp redistribute-internal
```

Allows the redistribution of iBGP routes into an IGP, such as IS-IS or OSPF.

Step 4 Use the `commit` or `end` command.

commit — Saves the configuration changes and remains within the configuration session.

end — Prompts user to take one of these actions:

- **Yes** — Saves configuration changes and exits the configuration session.
- **No** — Exits the configuration session without committing the configuration changes.
- **Cancel** — Remains in the configuration session, without committing the configuration changes.

Redistribute IGP to BGP

Perform this task to configure redistribution of a protocol into the VRF address family.

Even if Interior Gateway Protocols (IGPs) are used as the PE-CE protocol, the import logic happens through BGP. Therefore, all IGP routes have to be imported into the BGP VRF table.

SUMMARY STEPS

1. `configure`
2. `router bgp as-number`
3. `vrf vrf-name`
4. `address-family { ipv4 | ipv6 } unicast`
5. Do one of the following:
 - `redistribute connected [metric metric-value] [route-policy route-policy-name]`
 - `redistribute isis process-id [level { 1 | 1-inter-area | 2 }] [metric metric-value] [route-policy route-policy-name]`
 - `redistribute ospf process-id [match { external [1 | 2] | internal | nssa-external [1 | 2] }] [metric metric-value] [route-policy route-policy-name]`
 - `redistribute ospfv3 process-id [match { external [1 | 2] | internal | nssa-external [1 | 2] }] [metric metric-value] [route-policy route-policy-name]`

- **redistribute rip** [**metric** *metric-value*] [**route-policy** *route-policy-name*]
- **redistribute static** [**metric** *metric-value*] [**route-policy** *route-policy-name*]

6. Use the **commit** or **end** command.

DETAILED STEPS

Step 1 **configure**

Example:

```
RP/0/RP0/CPU0:router# configure
```

Enters global configuration mode.

Step 2 **router bgp** *as-number*

Example:

```
RP/0/RP0/CPU0:router(config)# router bgp 120
```

Specifies the autonomous system number and enters the BGP configuration mode, allowing you to configure the BGP routing process.

Step 3 **vrf** *vrf-name*

Example:

```
RP/0/RP0/CPU0:router(config-bgp)# vrf vrf_a
```

Enables BGP routing for a particular VRF on the PE router.

Step 4 **address-family** { **ipv4** | **ipv6** } **unicast**

Example:

```
RP/0/RP0/CPU0:router(config-vrf)# address-family ipv4 unicast
```

Specifies either an IPv4 or IPv6 address family unicast and enters address family configuration submode.

To see a list of all the possible keywords and arguments for this command, use the CLI help (?).

Step 5 Do one of the following:

- **redistribute connected** [**metric** *metric-value*] [**route-policy** *route-policy-name*]
- **redistribute isis** *process-id* [**level** { **1** | **1-inter-area** | **2** }] [**metric** *metric-value*] [**route-policy** *route-policy-name*]
- **redistribute ospf** *process-id* [**match** { **external** [**1** | **2**] | **internal** | **nssa-external** [**1** | **2**] }] [**metric** *metric-value*] [**route-policy** *route-policy-name*]
- **redistribute ospfv3** *process-id* [**match** { **external** [**1** | **2**] | **internal** | **nssa-external** [**1** | **2**] }] [**metric** *metric-value*] [**route-policy** *route-policy-name*]
- **redistribute rip** [**metric** *metric-value*] [**route-policy** *route-policy-name*]
- **redistribute static** [**metric** *metric-value*] [**route-policy** *route-policy-name*]

Example:

```
RP/0/RP0/CPU0:router(config-bgp-vrf-af)# redistribute ospf 1
```

Configures redistribution of a protocol into the VRF address family context.

The **redistribute** command is used if BGP is not used between the PE-CE routers. If BGP is used between PE-CE routers, the IGP that is used has to be redistributed into BGP to establish VPN connectivity with other PE sites. Redistribution is also required for inter-table import and export.

Step 6 Use the **commit** or **end** command.

commit —Saves the configuration changes and remains within the configuration session.

end —Prompts user to take one of these actions:

- **Yes** — Saves configuration changes and exits the configuration session.
- **No** —Exits the configuration session without committing the configuration changes.
- **Cancel** —Remains in the configuration session, without committing the configuration changes.

Update Groups

The BGP Update Groups feature contains an algorithm that dynamically calculates and optimizes update groups of neighbors that share outbound policies and can share the update messages. The BGP Update Groups feature separates update group replication from peer group configuration, improving convergence time and flexibility of neighbor configuration.

Monitor BGP Update Groups

This task displays information related to the processing of BGP update groups.

SUMMARY STEPS

1. **show bgp** [**ipv4** { **unicast** | **multicast** | **all** | **tunnel** } | **ipv6** { **unicast** | **all** } | **all** { **unicast** | **multicast** | **all** | **labeled-unicast** | **tunnel** } | **vpn4 unicast** | **vrf** { *vrf-name* | **all** } [**ipv4 unicast** | **ipv6 unicast**] | **vpn6 unicast**] **update-group** [**neighbor** *ip-address* | *process-id.index* [**summary** | **performance-statistics**]]

DETAILED STEPS

```
show bgp [ ipv4 { unicast | multicast | all | tunnel } | ipv6 { unicast | all } | all { unicast | multicast | all | labeled-unicast | tunnel } | vpn4 unicast | vrf { vrf-name | all } [ ipv4 unicast | ipv6 unicast ] | vpn6 unicast ] update-group [ neighbor ip-address | process-id.index [ summary | performance-statistics ] ]
```

Example:

```
RP/0/RP0/CPU0:router# show bgp update-group 0.0
```

Displays information about BGP update groups.

- The *ip-address* argument displays the update groups to which that neighbor belongs.

- The *process-id.index* argument selects a particular update group to display and is specified as follows: process ID (dot) index. Process ID range is from 0 to 254. Index range is from 0 to 4294967295.
- The **summary** keyword displays summary information for neighbors in a particular update group.
- If no argument is specified, this command displays information for all update groups (for the specified address family).
- The **performance-statistics** keyword displays performance statistics for an update group.

Displaying BGP Update Groups: Example

The following is sample output from the **show bgp update-group** command run in EXEC configurationXR EXEC mode:

```
show bgp update-group

Update group for IPv4 Unicast, index 0.1:
Attributes:
  Outbound Route map:rm
  Minimum advertisement interval:30
  Messages formatted:2, replicated:2
  Neighbors in this update group:
    10.0.101.92

Update group for IPv4 Unicast, index 0.2:
Attributes:
  Minimum advertisement interval:30
  Messages formatted:2, replicated:2
  Neighbors in this update group:
    10.0.101.91
```

L3VPN iBGP PE-CE

The L3VPN iBGP PE-CE feature helps establish an iBGP (internal Border Gateway Protocol) session between the provider edge (PE) and customer edge (CE) devices to exchange BGP routing information. A BGP session between two BGP peers is said to be an iBGP session if the BGP peers are in the same autonomous systems.

Restrictions for L3VPN iBGP PE-CE

The following restrictions apply to configuring L3VPN iBGP PE-CE:

- When the iBGP PE CE feature is toggled and the neighbor no longer supports route-refresh or soft-reconfiguration inbound, a manual session flap must be done to see the change. When this occurs, the following message is displayed:

```
RP/0/0/CPU0: %ROUTING-BGP-5-CFG_CHG_RESET: Internal VPN client configuration change on
  neighbor 10.10.10.1 requires HARD reset
(clear bgp 10.10.10.1) to take effect.
```
- iBGP PE CE CLI configuration is not available for peers under default-VRF, except for neighbor/session-group.

- This feature does not work on regular VPN clients (eBGP VPN clients).
- Attributes packed inside the ATTR_SET reflects changes made by the inbound route-policy on the iBGP CE and does not reflect the changes made by the export route-policy for the specified VRF.
- Different VRFs of the same VPN (that is, in different PE routers) that are configured with iBGP PE-CE peering sessions must use different Route Distinguisher (RD) values under respective VRFs. The iBGP PE CE feature does not work if the RD values are the same for the ingress and egress VRF.

Configuring L3VPN iBGP PE-CE

L3VPN iBGP PE-CE can be enabled on the neighbor, neighbor-group, or session-group. To configure L3VPN iBGP PE-CE, follow these steps:

Before you begin

The CE must be an internal BGP peer.

SUMMARY STEPS

1. **configure**
2. **router bgp** *as-number*
3. **vrf** *vrf-name*
4. **neighbor** *ip-address* **internal-vpn-client**
5. Use the **commit** or **end** command.
6. **show bgp vrf** *vrf-name* **neighbors** *ip-address*
7. **show bgp** { **vpn4** | **vpn6** } **unicast rd**

DETAILED STEPS

Step 1 **configure**

Example:

```
RP/0/RP0/CPU0:router# configure
```

Enters global configuration mode.

Step 2 **router bgp** *as-number*

Example:

```
RP/0/RP0/CPU0:router(config)# router bgp 120
```

Specifies the autonomous system number and enters the BGP configuration mode, allowing you to configure the BGP routing process.

Step 3 **vrf** *vrf-name*

Example:

```
RP/0/RP0/CPU0:router(config-bgp)# vrf blue
```

Configures a VRF instance.

Step 4 `neighbor ip-address internal-vpn-client`

Example:

```
RP/0/RP0/CPU0:router(config-bgp-vrf)# neighbor 10.0.0.0 internal-vpn-client
```

Configures a CE neighboring device with which to exchange routing information. The **neighbor internal-vpn-client** command stacks the iBGP-CE neighbor path in the VPN attribute set.

Step 5 Use the **commit** or **end** command.

commit —Saves the configuration changes and remains within the configuration session.

end —Prompts user to take one of these actions:

- **Yes** — Saves configuration changes and exits the configuration session.
- **No** —Exits the configuration session without committing the configuration changes.
- **Cancel** —Remains in the configuration session, without committing the configuration changes.

Step 6 `show bgp vrf vrf-name neighbors ip-address`

Displays whether the iBGP PE-CE feature is enabled for the VRF CE peer, or not.

Step 7 `show bgp { vpnv4 | vpnv6 } unicast rd`

Displays the ATTR_SET attributes in the command output when the L3VPN iBGP PE-CE is enabled on a CE.

Example

Example: Configuring L3VPN iBGP PE-CE

The following example shows how to configure L3VPN iBGP PE-CE:

```
R1(config-bgp-vrf-nbr)#neighbor 10.10.10.1 ?
. . .
  internal-vpn-client      Preserve iBGP CE neighbor path in ATTR_SET across VPN core
. . .
R1(config-bgp-vrf-nbr)#neighbor 10.10.10.1 internal-vpn-client
router bgp 65001
  bgp router-id 100.100.100.2
  address-family ipv4 unicast
  address-family vpnv4 unicast
  !
  vrf ce-ibgp
    rd 65001:100
    address-family ipv4 unicast
    !
    neighbor 10.10.10.1
      remote-as 65001
      internal-vpn-client
```

The following is an example of the output of the **show bgp vrf vrf-name neighbors ip-address** command when the L3VPN iBGP PE-CE is enabled on a CE peer:

```
R1#show bgp vrf ce-ibgp neighbors 10.10.10.1
BGP neighbor is 10.10.10.1, vrf ce-ibgp
  Remote AS 65001, local AS 65001, internal link
  Remote router ID 100.100.100.1
  BGP state = Established, up for 00:00:19
  . . .
Multi-protocol capability received
Neighbor capabilities:
  Route refresh: advertised (old + new) and received (old + new)
  4-byte AS: advertised and received
  Address family IPv4 Unicast: advertised and received
CE attributes will be preserved across the core
  Received 2 messages, 0 notifications, 0 in queue
  Sent 2 messages, 0 notifications, 0 in queue
  . . .
```

The following is an example of the output of the **show bgp vpn4/vpn6 unicast rd** command when the L3VPN iBGP PE-CE is enabled on a CE peer:

```
BGP routing table entry for 1.1.1.0/24, Route Distinguisher: 200:300
Versions:
  Process          bRIB/RIB  SendTblVer
  Speaker          10        10
Last Modified: Aug 28 13:11:17.000 for 00:01:00
Paths: (1 available, best #1)
  Advertised to update-groups (with more than one peer):
    0.2
Path #1: Received by speaker 0
  Advertised to update-groups (with more than one peer):
    0.2
Local, (Received from a RR-client)
  20.20.20.2 from 20.20.20.2 (100.100.100.2)
  Received Label 24000
  Origin IGP, localpref 100, valid, internal, best, group-best, import-candidate,
  not-in-vrf Received Path ID 0, Local Path ID 1, version 10
  Extended community: RT:228:237
ATTR-SET [
  Origin-AS: 200
  AS-Path: 51320 52325 59744 12947 21969 50346 18204 36304 41213
23906 33646
  Origin: incomplete
  Metric: 204
  Local-Pref: 234
  Aggregator: 304 34.3.3.3
  Atomic Aggregator
  Community: 1:60042 2:41661 3:47008 4:9280 5:39778 6:1069 7:15918
8:8994 9:52701
10:10268 11:26276 12:8506 13:7131 14:65464 15:14304 16:33615 17:54991
18:40149 19:19401
  Extended community: RT:100:1 RT:1.1.1.1:1]
```

Flow-tag propagation

The flow-tag propagation feature enables you to establish a co-relation between route-policies and user-policies. Flow-tag propagation using BGP allows user-side traffic-steering based on routing attributes such as, AS number, prefix lists, community strings and extended communities. Flow-tag is a logical numeric identifier that is distributed through RIB as one of the routing attribute of FIB entry in the FIB lookup table. A flow-tag

is instantiated using the 'set' operation from RPL and is referenced in the C3PL PBR policy, where it is associated with actions (policy-rules) against the flow-tag value.

You can use flow-tag propagation to:

- Classify traffic based on destination IP addresses (using the Community number) or based on prefixes (using Community number or AS number).
- Select a TE-group that matches the cost of the path to reach a service-edge based on customer site service level agreements (SLA).
- Apply traffic policy (TE-group selection) for specific customers based on SLA with its clients.
- Divert traffic to application or cache server.

Restrictions for Flow-Tag Propagation

Some restrictions are placed with regard to using Quality-of-service Policy Propagation Using Border Gateway Protocol (QPPB) and flow-tag feature together. These include:

- A route-policy can have either 'set qos-group' or 'set flow-tag,' but not both for a prefix-set.
- Route policy for qos-group and route policy flow-tag cannot have overlapping routes. The QPPB and flow tag features can coexist (on same as well as on different interfaces) as long as the route policy used by them do not have any overlapping route.
- Mixing usage of qos-group and flow-tag in route-policy and policy-map is not recommended.

Source and destination-based flow tag

The source-based flow tag feature allows you to match packets based on the flow-tag assigned to the source address of the incoming packets. Once matched, you can then apply any supported PBR action on this policy.

Configure Source and Destination-based Flow Tag

This task applies flow-tag to a specified interface. The packets are matched based on the flow-tag assigned to the source address of the incoming packets.



Note You will not be able to enable both QPPB and flow tag feature simultaneously on an interface.

SUMMARY STEPS

1. **configure**
2. **interface** *type interface-path-id*
3. **ipv4 | ipv6 bgp policy propagation input flow-tag** {**destination** | **source**}
4. Use the **commit** or **end** command.

DETAILED STEPS

Step 1 **configure**

Example:

```
RP/0/RP0/CPU0:router# configure
```

Enters global configuration mode.

Step 2 `interface type interface-path-id`

Example:

```
RP/0/RP0/CPU0:router(config-if)# interface
```

Enters interface configuration mode and associates one or more interfaces to the VRF.

Step 3 `ipv4 | ipv6 bgp policy propagation input flow-tag {destination | source}`

Example:

```
RP/0/RP0/CPU0:router(config-if)# ipv4 bgp policy propagation input flow-tag source
```

Enables flow-tag policy propagation on source or destination IP address on an interface.

Step 4 Use the **commit** or **end** command.

commit —Saves the configuration changes, and remains within the configuration session.

end —Prompts user to take one of these actions:

- **Yes** — Saves configuration changes and exits the configuration session.
- **No** —Exits the configuration session without committing the configuration changes.
- **Cancel** —Remains in the configuration mode, without committing the configuration changes.

Example

The following show commands display outputs with PBR policy applied on the router:

```
show running-config interface gigabitEthernet 0/0/0/12
Thu Feb 12 01:51:37.820 UTC
interface GigabitEthernet0/0/0/12
  service-policy type pbr input flowMatchPolicy
  ipv4 bgp policy propagation input flow-tag source
  ipv4 address 192.5.1.2 255.255.255.0
!

RP/0/RSP0/CPU0:ASR9K-0#show running-config policy-map type pbr flowMatchPolicy
Thu Feb 12 01:51:45.776 UTC
policy-map type pbr flowMatchPolicy
  class type traffic flowMatch36
    transmit
  !
  class type traffic flowMatch38
    transmit
  !
  class type traffic class-default
  !
end-policy-map
!

RP/0/RSP0/CPU0:ASR9K-0#show running-config class-map type traffic flowMatch36
```

```

Thu Feb 12 01:52:04.838 UTC
class-map type traffic match-any flowMatch36
  match flow-tag 36
end-class-map
!

```

BGP Keychains

BGP keychains enable keychain authentication between two BGP peers. The BGP endpoints must both comply with draft-bonica-tcp-auth-05.txt and a keychain on one endpoint and a password on the other endpoint does not work.

BGP is able to use the keychain to implement hitless key rollover for authentication. Key rollover specification is time based, and in the event of clock skew between the peers, the rollover process is impacted. The configurable tolerance specification allows for the accept window to be extended (before and after) by that margin. This accept window facilitates a hitless key rollover for applications (for example, routing and management protocols).

The key rollover does not impact the BGP session, unless there is a keychain configuration mismatch at the endpoints resulting in no common keys for the session traffic (send or accept).

Configure Keychains for BGP

Keychains provide secure authentication by supporting different MAC authentication algorithms and provide graceful key rollover. Perform this task to configure keychains for BGP. This task is optional.



Note If a keychain is configured for a neighbor group or a session group, a neighbor using the group inherits the keychain. Values of commands configured specifically for a neighbor override inherited values.

SUMMARY STEPS

1. **configure**
2. **router bgp** *as-number*
3. **neighbor** *ip-address*
4. **remote-as** *as-number*
5. **keychain** *name*
6. Use the **commit** or **end** command.

DETAILED STEPS

Step 1 **configure**

Example:

```
RP/0/RP0/CPU0:router# configure
```

Enters global configuration mode.

Step 2 **router bgp** *as-number*

Example:

```
RP/0/RP0/CPU0:router(config)# router bgp 120
```

Specifies the autonomous system number and enters the BGP configuration mode, allowing you to configure the BGP routing process.

Step 3 **neighbor** *ip-address***Example:**

```
RP/0/RP0/CPU0:router(config-bgp)# neighbor 172.168.40.24
```

Places the router in neighbor configuration mode for BGP routing and configures the neighbor IP address as a BGP peer.

Step 4 **remote-as** *as-number***Example:**

```
RP/0/RP0/CPU0:router(config-bgp-nbr)# remote-as 2002
```

Creates a neighbor and assigns a remote autonomous system number to it.

Step 5 **keychain** *name***Example:**

```
RP/0/RP0/CPU0:router(config-bgp-nbr)# keychain kych_a
```

Configures keychain-based authentication.

Step 6 Use the **commit** or **end** command.

commit —Saves the configuration changes and remains within the configuration session.

end —Prompts user to take one of these actions:

- **Yes** — Saves configuration changes and exits the configuration session.
- **No** —Exits the configuration session without committing the configuration changes.
- **Cancel** —Remains in the configuration session, without committing the configuration changes.

Master Key Tuple Configuration

This feature specifies TCP Authentication Option (TCP-AO), which replaces the TCP MD5 option. TCP-AO uses the Message Authentication Codes (MACs), which provides the following:

- Protection against replays for long-lived TCP connections
- More details on the security association with TCP connections than TCP MD5
- A larger set of MACs with minimal other system and operational changes

TCP-AO is compatible with Master Key Tuple (MKT) configuration. TCP-AO also protects connections when using the same MKT across repeated instances of a connection. TCP-AO protects the connections by using traffic key that are derived from the MKT, and then coordinates changes between the endpoints.



Note TCPAO and TCP MD5 are never permitted to be used simultaneously. TCP-AO supports IPv6, and is fully compatible with the proposed requirements for the replacement of TCP MD5.

Cisco provides the MKT configuration via the following configurations:

- keychain configuration
- tcp ao keychain configuration

The system translates each key, such “key_id” that is under a keychain, as MKT. The keychain configuration owns part of the configuration like secret, lifetimes, and algorithms. While the “tcp ao keychain” mode owns the TCP AO-specific configuration for an MKT (send_id and receive_id).

Keychain Configurations

Configuration Guidelines

In order to run a successful configuration, ensure that you follow the configuration guidelines:

- An allowed value range for both Send_ID and Receive_ID is 0 to 255.
- You can link only one keychain to an application neighbor.
- Under the same keychain, if you configure the same send_id key again under the keys that have an overlapping lifetime, then the old key becomes unusable until you correct the configuration.
- The system sends a warning message in the following scenarios:
 - If there is a change in Send_ID or Receive_ID.
 - If the corresponding key is currently active, and is in use by some connection.
- BGP neighbor can ONLY use one of the authentication options:
 - MD5
 - EA
 - AO



Note If you configure one of these options, the system rejects the other authentication options during the configuration time.

Configuration Guidelines for TCP AO BGP Neighbor

The configuration guidelines are:

- Configure all the necessary configurations (key_string, MAC_algorithm, send_lifetime, accept_lifetime, send_id, receive_id) under key_id with the desired lifetime it wants to use the key_id for.
- Configure a matching MKT in the peer side with exactly same lifetime.

- Once a keychain-key is linked to tcp-ao, do not change the components of the key. If you want TCP to consider another key for use, you can configure that dynamically. Based on the 'start-time' of send lifetime, TCP AO uses the key.
- Send_ID and Receive_ID under a key_id (under a keychain) must have the same lifetime range. For example, send-lifetime==accept-lifetime.

TCP considers only expiry of send-lifetime to transition to next active key and it does not consider accept-lifetime at all.

- Do not configure a key with send-lifetime that is covered by another key's send-lifetime.

For example, if there is a key that is already configured with send-lifetime of "04:00:00 November 01, 2017 07:00:00 November 01, 2017" and the user now configures another key with send-lifetime of "05:00:00 November 01, 2017 06:00:00 November 01, 2017", this might result into connection flap.

TCP AO tries to transition back to the old key once the new key is expired. However, if the new key has already expired, TCP AO can't use it, which might result in segment loss and hence connection flap.

- Configure minimum of 15 minutes of overlapping time between the two overlapping keys. When a key expires, TCP does not use it and hence out-of-order segments with that key are dropped.
- We recommend configuring send_id and receive_id to be same for a key_id for simplicity.
- TCP does not have any restriction on the number of keychains and keys under a keychain. The system does not support more than 4000 keychains, any number higher than 4000 might result in unexpected behaviors.

Keychain Configuration

```
key chain <keychain_name>
  key <key_id>
    accept-lifetime <start-time> <end-time>
    key-string <master-key>
    send-lifetime <start-time> <end-time>
    cryptographic-algorithm <algorithm>
  !
!
```

TCP Configuration

TCP provides a new tcp ao submode that specifies SendID and ReceiveID per key_id per keychain.

```
tcp ao
  keychain <keychain_name1>
    key-id <key_id> send_id <0-255> receive_id <0-255>
  !
```

Example:

```
tcp ao
  keychain bgp_ao
    key 0 SendID 0 ReceiveID 0
    key 1 SendID 1 ReceiveID 1
    key 2 SendID 3 ReceiveID 4
  !
  keychain ldp_ao
    key 1 SendID 100 ReceiveID 200
    key 120 SendID 1 ReceiveID 1
  !
```

BGP Configurations

Applications like BGP provide the tcp-ao keychain and related information that it uses per neighbor. Following are the optional configurations per tcp-ao keychain:

- include-tcp-options
- accept-non-ao-connections

```
router bgp <AS-number>
neighbor <neighbor-ip>
  remote-as <remote-as-number>
  ao <keychain-name> include-tcp-options enable/disable <accept-ao-mismatch-connections>
!
```

XML Configurations

BGP XML

TCP-AO XML

```
<?xml version="1.0" encoding="UTF-8"?>
<Request>
<Set>
  <Configuration>
    <IP_TCP>
      <AO>
        <Enable>
          true
        </Enable>
        <KeychainTable>
          <Keychain>
            <Naming>
              <Name> bgp_ao_xml </Name>
            </Naming>
            <Enable>
              true
            </Enable>
            <KeyTable>
              <Key>
                <Naming>
                  <KeyID> 0 </KeyID>
                </Naming>
                <SendID> 0 </SendID>
                <ReceiveID> 0 </ReceiveID>
              </Key>
            </KeyTable>
          </Keychain>
        </KeychainTable>
      </AO>
    </IP_TCP>
  </Configuration>
</Set>
<Commit/>
</Request>
```

BGP Session Authentication and Integrity using TCP Authentication Option Overview

BGP Session Authentication and Integrity using TCP Authentication Option feature enables you to use stronger Message Authentication Codes that protect against replays, even for long-lived TCP connections. This feature also provides more details on the association of security with TCP connections than TCP MD5 Signature option (TCP MD5).

This feature supports the following functionalities of TCP MD5:

- Protection of long-lived connections such as BGP and LDP.
- Support for larger set of MACs with minimal changes to the system and operations

BGP Session Authentication and Integrity using TCP Authentication Option feature supports IPv6. It supports these two cryptographic algorithms: HMAC-SHA-1-96 and AES-128-CMAC-96.

You can use two sets of keys, namely Master Key Tuples and traffic keys to authenticate incoming and outgoing segments.

This feature applies different option identifier than TCP MD5. This feature cannot be used simultaneously with TCP MD5.

Master Key Tuples

Traffic keys are the keying material used to compute the message authentication codes of individual TCP segments.

The BGP Session Authentication and Integrity using TCP Authentication Option (AO) feature uses the existing keychain functionality to define the key string, message authentication codes algorithm, and key lifetimes.

Master Key Tuples (MKTs) enable you to derive unique traffic keys, and to include the keying material required to generate those traffic keys. MKTs indicate the parameters under which the traffic keys are configured. The parameters include whether TCP options are authenticated, and indicators of the algorithms used for traffic key derivation and MAC calculation.

Each MKT has two identifiers, namely **SendID** and a **RecvID**. The SendID identifier is inserted as the KeyID identifier of the TCP AO option of the outgoing segments. The **RecvID** is matched against the TCP AO KeyID of the incoming segments.

Configure BGP Session Authentication and Integrity using TCP Authentication Option

This section describes how you can configure BGP Session Authentication and Integrity using TCP Authentication Option (TCP AO) feature :

- Configure Keychain



Note Configure send-life and accept-lifetime keywords with identical values in the keychain configuration, otherwise the values become invalid.

- Configure TCP



Note The Send ID and Receive ID you configured on the device must match the Receive ID and Send ID configured on the peer respectively.

- Configure BGP

Configuration Example

Configure a keychain.

```
Router# configure
Router#(config)# key chain tcpaol
Router#(config-tcpaol)# key 1
Router#(config-tcpaol-1)# cryptographic-algorithm HMAC-SHA-1-96
Router#(config-tcpaol-1)# key-string keys1
Router#(config-tcpaol-1)# send-lifetime 16:00:00 march 3 2018 infinite
Router#(config-tcpaol-1)# accept-lifetime 16:00:00 march 3 2018 infinite
```

Configure TCP

```
Router# tcp ao
Router(config-tcp-ao)# keychain tcpaol
Router(config-tcp-ao-tpcaol)# key 1 sendID 5 receiveID 5
/* Configure BGP */
Router#(config-bgp)# router bgp 1
Router(config-bgp)# bgp router-id 10.101.101.1
Router(config-bgp)# address-family ipv4 unicast
Router(config-bgp-af)# exit
Router(config-bgp)# neighbor 10.51.51.1
Router(config-bgp-nbr)# remote-as 1
Router(config-bgp-nbr)# ao tcpaol include-tcp-options disable accept-ao-mismatch-connection
```

Configure BGP

```
Router#(config-bgp)# router bgp 1
Router(config-bgp)# bgp router-id 10.101.101.1
Router(config-bgp)# address-family ipv4 unicast
Router(config-bgp-af)# exit
Router(config-bgp)# neighbor 10.51.51.1
Router(config-bgp-nbr)# remote-as 1
Router(config-bgp-nbr)# ao tcpaol include-tcp-options disable accept-ao-mismatch-connection
```

Verification

Verify the keychain information configured for BGP Session Authentication and Integrity using TCP Authentication Option feature.

```
Router# show bgp sessions | i 10.51.51.1
Wed Mar 21 12:55:57.812 UTC
10.51.51.1 default 1 1 0 0 Established None
```

The following output displays details of a key, such as Send Id, Receive Id, and cryptographic algorithm.

```
Router# show bgp sessions | i 10.51.51.1
```



```
Wed Mar 21 12:55:57.812 UTC
10.51.51.1 default 1 1 0 0 Established None
```

The following output displays the state of the BGP neighbors.

```
Router# show bgp sessions | i 10.51.51.1
Wed Mar 21 12:55:57.812 UTC
10.51.51.1 default 1 1 0 0 Established None
```

The following output displays the state of a particular BGP neighbor.

```
Router# show bgp sessions | i 10.51.51.1
Wed Mar 21 12:55:57.812 UTC
10.51.51.1 default 1 1 0 0 Established None
```

The following output displays brief information of the protocol control block (PCB) of the neighbor.

```
Router# show tcp brief | i 10.51.51.2
Wed Mar 21 12:55:13.652 UTC
0x143df858 0x60000000 0 0 10.51.51.2:43387 10.51.51.1:179 ESTAB
```

The following output displays authentication details of the PCB:

```
Router# show tcp detail pcb 0x143df858 location 0/rsp0/CPU0 | begin Authen
Wed Mar 21 12:56:46.129 UTC
Authentication peer details:
Peer: 10.51.51.1/32, OBJ_ID: 0x40002fd8
Port: BGP, vrf_id: 0x60000000, type: AO, debug_on:0
Keychain_name: tcpaol, options: 0x00000000, linked peer: 0x143e00 □ Keychain name
Send_SNE: 0, Receive_SNE: 0, Send_SNE_flag: 0
Recv_SNE_flag: 0, Prev_send_seq: 4120835405, Prev_receive_seq: 2461932863
ISS: 4120797604, IRS: 2461857361
Current key: 2
Traffic keys: send_non_SYN: 006a2975, recv_non_SYN: 00000000
RNext key: 2
Traffic keys: send_non_SYN: 00000000, recv_non_SYN: 00000000
Last 1 keys used:
key: 2, time: Mar 20 03:52:35.969.151, reason: No current key set
```

BGP Nonstop Routing

The Border Gateway Protocol (BGP) Nonstop Routing (NSR) with Stateful Switchover (SSO) feature enables all bgp peerings to maintain the BGP state and ensure continuous packet forwarding during events that could interrupt service. Under NSR, events that might potentially interrupt service are not visible to peer routers. Protocol sessions are not interrupted and routing states are maintained across process restarts and switchovers.

[BGP Nonstop Routing Reference, on page 22](#) for additional details.

Configure BGP Nonstop Routing

BGP Nonstop Routing (BGP NSR) is enabled by default. If BGP NSR is disabled, use the **no nsr disable** command to turn BGP NSR back on.



Note In some scenarios, it is possible that some or all bgp sessions are not NSR-READY. The `show redundancy` command may still show that the bgp sessions are NSR-ready. Hence, we recommend that you verify the bgp nsr state by using the `show bgp sessions` command.

Disable BGP Nonstop Routing

Perform this task to disable BGP Nonstop Routing (NSR):

SUMMARY STEPS

1. **configure**
2. **router bgp** *as-number*
3. **nsr disable**
4. Use the **commit** or **end** command.

DETAILED STEPS

Step 1 **configure**

Example:

```
RP/0/RP0/CPU0:router# configure
```

Enters global configuration mode.

Step 2 **router bgp** *as-number*

Example:

```
RP/0/RP0/CPU0:router(config)# router bgp 120
```

Specifies the BGP AS number, and enters the BGP configuration mode, for configuring BGP routing processes.

Step 3 **nsr disable**

Example:

```
RP/0/RP0/CPU0:router(config-bgp)# nsr disable
```

Disables BGP Nonstop routing.

Step 4 Use the **commit** or **end** command.

commit —Saves the configuration changes and remains within the configuration session.

end —Prompts user to take one of these actions:

- **Yes** — Saves configuration changes and exits the configuration session.
- **No** —Exits the configuration session without committing the configuration changes.

- **Cancel**—Remains in the configuration session, without committing the configuration changes.

Disable BGP Nonstop Routing: Example

The following example shows how to disable BGP NSR:

```
configure
router bgp 120
no nsr
end
```

Re-enable BGP Nonstop Routing

If BGP Nonstop Routing (NSR) is disabled, use the following steps to turn BGP NSR back on using the following steps:

SUMMARY STEPS

1. **configure**
2. **router bgp** *as-number*
3. **no nsr disable**
4. Use the **commit** or **end** command.

DETAILED STEPS

Step 1 **configure**

Example:

```
RP/0/RP0/CPU0:router# configure
```

Enters global configuration mode.

Step 2 **router bgp** *as-number*

Example:

```
RP/0/RP0/CPU0:router(config)# router bgp 120
```

Specifies the BGP AS number, and enters the BGP configuration mode, for configuring BGP routing processes.

Step 3 **no nsr disable**

Example:

```
RP/0/RP0/CPU0:router(config-bgp)# nsr disable
```

Enables BGP Nonstop routing.

Step 4 Use the **commit** or **end** command.

commit—Saves the configuration changes and remains within the configuration session.

end —Prompts user to take one of these actions:

- **Yes** — Saves configuration changes and exits the configuration session.
- **No** —Exits the configuration session without committing the configuration changes.
- **Cancel** —Remains in the configuration session, without committing the configuration changes.

Re-enable BGP Nonstop Routing: Example

The following example shows how to enable BGP NSR:

```
configure
router bgp 120
nsr
end
```

Resilient Hashing and Flow Auto-Recovery

Resilient Hashing and Flow Auto-Recovery feature provides an option to selectively override the default equal cost multipath (ECMP) behavior during a ECMP path failure. This feature enables the redirection of flows through inactive links only and the prevention of all existing flows from being rehashed to a new link. This feature also provides an option to recover a link or a server when it comes back so it can be reused for sessions.

ECMP Path Failure

Prior to the implementation of Resilient Hashing and Flow Auto-Recovery feature, ECMP would load balance the traffic over a number of available paths towards a destination. When one path fails, the traffic gets rehashed over a new set of paths and elects a new next-hop for each path.

Figure 2: ECMP Path Failure

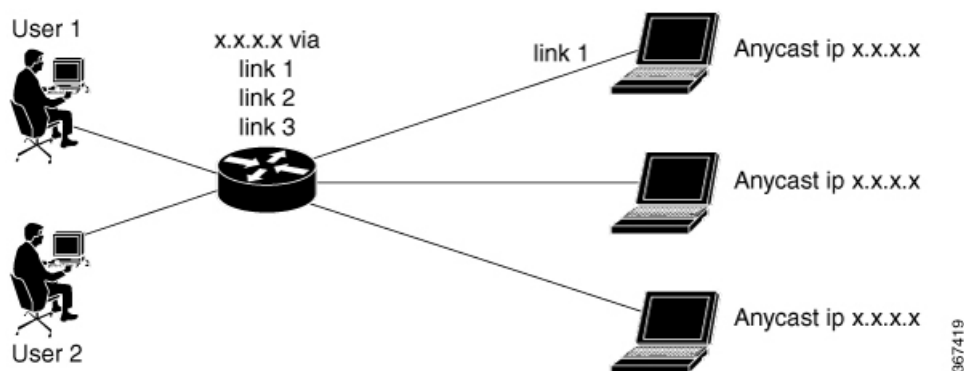

For example, as shown in the figure, among three links link 1, link 2, and link 3, the traffic flow that took link 1 before the failure, takes link 3 after the failure although only link 2 failed.

This traffic flow redistribution does not cause any problem in traditional core networks because the end-to-end connectivity is preserved and the user does not encounter problems from it. However, in data center environments, load balancing due to traffic flow redistribution can cause a problem.

In data center environments where multiple servers are connected through ECMP, the loss of traffic on active link caused by this rehashing resets the TCP session.

Figure 3: Resilient Hashing and Flow Auto-Recovery

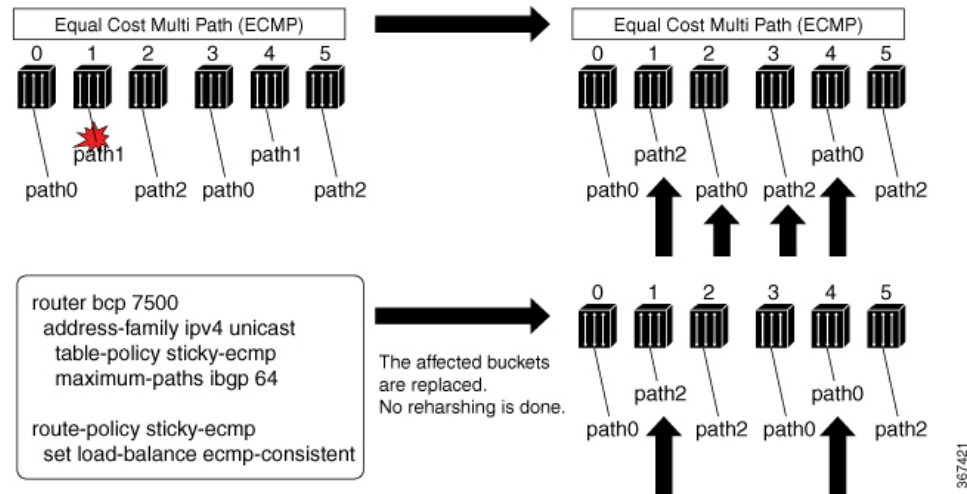

The above figure shows how complete rehashing of paths occurs when path 1 fails. However, when Resilient Hashing and Flow Auto-Recovery feature is configured, only the affected buckets are replaced. No rehashing is done. Use an RPL to define prefixes that require resilient hashing and flow auto-recovery. Each prefix has a path list, say for example a prefix 'X' has a path list namely, path 0, path 1, path 2. For example, when path 1 fails and when you have configured Resilient Hashing and Flow Auto-Recovery feature, the new path list becomes (path 0, path 0, and path 2), instead of the default rehash logic, which results (path 0, path 2, and path 0).

When path 1 becomes active, if the Resilient Hashing and Flow Auto-Recovery feature is not configured, no rehashing is done and the path is not utilized until one of the following occurs:

- Addition of new path to ECMP
- Use of **clear route** command.
- Removal of table-policy, commit, addition of table-policy, and commit
- Configuration of **cef consistent-hashing auto-recovery** command

When path 1 becomes active, if the Resilient Hashing and Flow Auto-Recovery feature is configured, the sessions get reshuffled automatically. This causes the sessions, which were moved from the failed path to a new server, to be rehashed back to the original server that became active. Hence, only these sessions are disrupted.

Persistent Loadbalancing

Traditional ECMP or equal cost multipath loadbalances traffic over a number of available paths towards a destination. When one path fails, the traffic gets re-shuffled over the available number of paths. This flow distribution can be a problem in data center loadbalancing.

Persistent Loadbalancing or Sticky ECMP defines a prefix in such a way that it do not rehash flows on existing paths and only replace those bucket assignments of the failed server. The advantage is that the established sessions to servers will not get rehashed.

The following section describes how you can configure persistent load balancing:

```
/*Configure persistent load balancing. */

Router(config)# router bgp 7500
Router(config-bgp)# address-family ipv4 unicast
Router(config-bgp-af)# table-policy sticky-ecmp
Router(config-bgp-af)# bgp attribute-download
Router(config-bgp-af)# maximum-paths ebgp 64
Router(config-bgp-af)# maximum-paths ibgp 32
Router(config-bgp-af)# exit
Router(config-bgp)# exit
Router(config)# route-policy sticky-ecmp
Router(config-rpl)# if destination in (192.1.1.1/24) then
Router(config-rpl-if)# set load-balance ecmp-consistent
Router(config-rpl-if)# else
Router(config-rpl-else)# pass
Router(config-rpl-else)# endif
RP/0/0/CPU0:ios(config-rpl)# end-policy
RP/0/0/CPU0:ios(config)#

/* Enable autocoverly and hence recover the original hashing state
after failed paths become active. */
Router(config)# cef consistent-hashing auto-recovery

/* Recover to the original hashing state after failed paths come up
and avoid affecting newly formed flows after path failure. */
Router(config)# clear route 192.0.2.0/24
```

Running Configuration

```
/* Configure persistent loadbalancing. */
router bgp 7500
  address-family ipv4 unicast
    table-policy sticky-ecmp
    bgp attribute-download
    maximum-paths ebgp 64
    maximum-paths ibgp 32

  cef consistent-hashing auto-recovery

  clear route 192.0.2.0/24
```

Verification

Verify that the path distribution with persistent loadbalancing is configured.

The following show output displays the status of path distribution before a link fails. In this output, three paths are identified with three next hops (10.1/2/3.0.1) through three different GigabitEthernet interfaces.

```
show cef 192.0.2.0/24
LDI Update time Sep  5 11:22:38.201
  via 10.1.0.1/32, 3 dependencies, recursive, bgp-multipath [flags 0x6080]
    path-idx 0 NHID 0x0 [0x57ac4e74 0x0]
    next hop 10.1.0.1/32 via 10.1.0.1/32
  via 10.2.0.1/32, 3 dependencies, recursive, bgp-multipath [flags 0x6080]
    path-idx 1 NHID 0x0 [0x57ac4a74 0x0]
    next hop 10.2.0.1/32 via 10.2.0.1/32
  via 10.3.0.1/32, 3 dependencies, recursive, bgp-multipath [flags 0x6080]
    path-idx 2 NHID 0x0 [0x57ac4f74 0x0]
    next hop 10.3.0.1/32 via 10.3.0.1/32
```

```

Load distribution (consistent): 0 1 2 (refcount 1)

Hash OK Interface Address
0 Y GigabitEthernet0/0/0/0 10.1.0.1
1 Y GigabitEthernet0/0/0/1 10.2.0.1
2 Y GigabitEthernet0/0/0/2 10.3.0.1

```

The following show output displays the status of the path distribution after a link fails. The replacement of bucket 1 with GigabitEthernet 0/0/0/0 and the "*" symbol denotes that this path is a replacement for a failed path.

```

show cef 192.0.2.0/24
LDI Update time Sep 5 11:23:13.434
  via 10.1.0.1/32, 3 dependencies, recursive, bgp-multipath [flags 0x6080]
    path-idx 0 NHID 0x0 [0x57ac4e74 0x0]
    next hop 10.1.0.1/32 via 10.1.0.1/32
  via 10.3.0.1/32, 3 dependencies, recursive, bgp-multipath [flags 0x6080]
    path-idx 1 NHID 0x0 [0x57ac4f74 0x0]
    next hop 10.3.0.1/32 via 10.3.0.1/32

Load distribution (consistent) : 0 1 2 (refcount 1)
Hash OK Interface Address
0 Y GigabitEthernet0/0/0/0 10.1.0.1
1* Y GigabitEthernet0/0/0/0 10.1.0.1
2 Y GigabitEthernet0/0/0/2 10.3.0.1

```

Accumulated Interior Gateway Protocol Attribute

The Accumulated Interior Gateway Protocol (AiGP) Attribute is an optional non-transitive BGP Path Attribute. The attribute type code for the AiGP Attribute is to be assigned by IANA. The value field of the AiGP Attribute is defined as a set of Type/Length/Value elements (TLVs). The AiGP TLV contains the Accumulated IGP Metric.

The AiGP feature is required in the 3107 network to simulate the current OSPF behavior of computing the distance associated with a path. OSPF/LDP carries the prefix/label information only in the local area. Then, BGP carries the prefix/label to all the remote areas by redistributing the routes into BGP at area boundaries. The routes/labels are then advertised using LSPs. The next hop for the route is changed at each ABR to local router which removes the need to leak OSPF routes across area boundaries. The bandwidth available on each of the core links is mapped to OSPF cost, hence it is imperative that BGP carries this cost correctly between each of the PEs. This functionality is achieved by using the AiGP.

Originate Prefixes with AiGP

Perform this task to configure origination of routes with the AiGP metric:

Before you begin

Origination of routes with the accumulated interior gateway protocol (AiGP) metric is controlled by configuration. AiGP attributes are attached to redistributed routes that satisfy following conditions:

- The protocol redistributing the route is enabled for AiGP.
- The route is an interior gateway protocol (iGP) route redistributed into border gateway protocol (BGP). The value assigned to the AiGP attribute is the value of iGP next hop to the route or as set by a route-policy.

- The route is a static route redistributed into BGP. The value assigned is the value of next hop to the route or as set by a route-policy.
- The route is imported into BGP through network statement. The value assigned is the value of next hop to the route or as set by a route-policy.

SUMMARY STEPS

1. **configure**
2. **route-policy** *aigp_policy*
3. **set aigp-metric***igp-cost*
4. **exit**
5. **router bgp** *as-number*
6. **address-family** {*ipv4* | *ipv6*} **unicast**
7. **redistribute ospf** *osp* **route-policy** *plcy_namemetric value*
8. Use the **commit** or **end** command.

DETAILED STEPS

Step 1 **configure**

Example:

```
RP/0/RP0/CPU0:router# configure
```

Enters global configuration mode.

Step 2 **route-policy** *aigp_policy*

Example:

```
RP/0/RP0/CPU0:router(config)# route-policy aip_policy
```

Enters route-policy configuration mode and sets the route-policy

Step 3 **set aigp-metric***igp-cost*

Example:

```
RP/0/RP0/CPU0:router(config-rpl)# set aigp-metric igp-cost
```

Sets the internal routing protocol cost as the aigp metric.

Step 4 **exit**

Example:

```
RP/0/RP0/CPU0:router(config-rpl)# exit
```

Exits route-policy configuration mode.

Step 5 **router bgp** *as-number*

Example:

```
RP/0/RP0/CPU0:router(config)# router bgp 100
```

Specifies the BGP AS number and enters the BGP configuration mode, allowing you to configure the BGP routing process.

Step 6 `address-family {ipv4 | ipv6} unicast`**Example:**

```
RP/0/RP0/CPU0:router(config-bgp)# address-family ipv4 unicast
```

Specifies either the IPv4 or IPv6 address family and enters address family configuration submode.

Step 7 `redistribute ospf osp route-policy plcy_name metric value`**Example:**

```
RP/0/RP0/CPU0:router(config-bgp-af)#redistribute ospf osp route-policy aigp_policy metric 1
```

Allows the redistribution of AiBGP metric into OSPF.

Step 8 Use the `commit` or `end` command.

commit — Saves the configuration changes and remains within the configuration session.

end — Prompts user to take one of these actions:

- **Yes** — Saves configuration changes and exits the configuration session.
- **No** — Exits the configuration session without committing the configuration changes.
- **Cancel** — Remains in the configuration session, without committing the configuration changes.

Originating Prefixes With AiGP: Example

The following is a sample configuration for originating prefixes with the AiGP metric attribute:

```
route-policy aigp-policy
  set aigp-metric 4
  set aigp-metric igp-cost
end-policy
!
router bgp 100
  address-family ipv4 unicast
    network 10.2.3.4/24 route-policy aigp-policy
    redistribute ospf osp1 metric 4 route-policy aigp-policy
  !
!
end
```

Configure BGP Accept Own

The BGP Accept Own feature allows you to handle self-originated VPN routes, which a BGP speaker receives from a route-reflector (RR). A 'self-originated' route is one which was originally advertised by the speaker itself. As per BGP protocol [RFC4271], a BGP speaker rejects advertisements that were originated by the speaker itself. However, the BGP Accept Own mechanism enables a router to accept the prefixes it has advertised, when reflected from a route-reflector that modifies certain attributes of the prefix. A special community called ACCEPT-OWN is attached to the prefix by the route-reflector, which is a signal to the receiving router to bypass the ORIGINATOR_ID and NEXTHOP/MP_REACH_NLRI check. Generally, the BGP speaker detects prefixes that are self-originated through the self-origination check (ORIGINATOR_ID,

NEXTHOP/MP_REACH_NLRI) and drops the received updates. However, with the Accept Own community present in the update, the BGP speaker handles the route.

One of the applications of BGP Accept Own is auto-configuration of extranets within MPLS VPN networks. In an extranet configuration, routes present in one VRF is imported into another VRF on the same PE. Normally, the extranet mechanism requires that either the import-rt or the import policy of the extranet VRFs be modified to control import of the prefixes from another VRF. However, with Accept Own feature, the route-reflector can assert that control without the need for any configuration change on the PE. This way, the Accept Own feature provides a centralized mechanism for administering control of route imports between different VRFs.



Note BGP Accept Own is supported only for VPNv4 and VPNv6 address families in neighbor configuration mode.

Perform this task to configure BGP Accept Own:

SUMMARY STEPS

1. **configure**
2. **router bgp** *as-number*
3. **neighbor** *ip-address*
4. **remote-as** *as-number*
5. **update-source** *type interface-path-id*
6. **address-family** {*vpnv4 unicast* | *vpnv6 unicast*}
7. **accept-own** [*inheritance-disable*]

DETAILED STEPS

Step 1 **configure**

Example:

```
RP/0/RP0/CPU0:router# configure
```

Enters global configuration mode.

Step 2 **router bgp** *as-number*

Example:

```
RP/0/RP0/CPU0:router(config)#router bgp 100
```

Specifies the autonomous system number and enters the BGP configuration mode, allowing you to configure the BGP routing process.

Step 3 **neighbor** *ip-address*

Example:

```
RP/0/RP0/CPU0:router(config-bgp)#neighbor 10.1.2.3
```

Places the router in neighbor configuration mode for BGP routing and configures the neighbor IP address as a BGP peer.

Step 4 **remote-as** *as-number*

Example:

```
RP/0/RP0/CPU0:router(config-bgp-nbr)#remote-as 100
```

Assigns a remote autonomous system number to the neighbor.

Step 5 `update-source type interface-path-id`

Example:

```
RP/0/RP0/CPU0:router(config-bgp-nbr)#update-source Loopback0
```

Allows sessions to use the primary IP address from a specific interface as the local address when forming a session with a neighbor.

Step 6 `address-family {vpn4 unicast | vpn6 unicast}`

Example:

```
RP/0/RP0/CPU0:router(config-bgp-nbr)#address-family vpn6 unicast
```

Specifies the address family as VPNv4 or VPNv6 and enters neighbor address family configuration mode.

Step 7 `accept-own [inheritance-disable]`

Example:

```
RP/0/RP0/CPU0:router(config-bgp-nbr-af)#accept-own
```

Enables handling of self-originated VPN routes containing Accept_Own community.

Use the **inheritance-disable** keyword to disable the "accept own" configuration and to prevent inheritance of "acceptown" from a parent configuration.

BGP Accept Own Configuration: Example

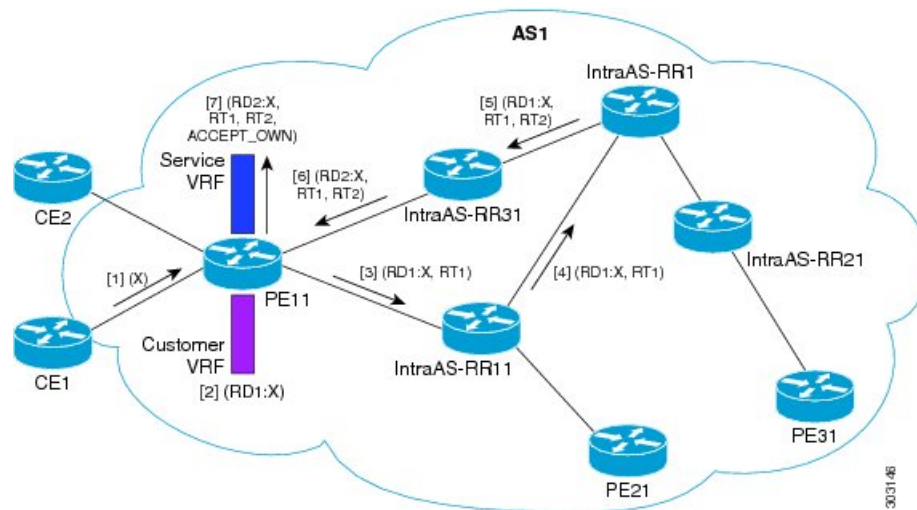

In this configuration example:

- PE11 is configured with Customer VRF and Service VRF.
- OSPF is used as the IGP.

- VPNv4 unicast and VPNv6 unicast address families are enabled between the PE and RR neighbors and IPv4 and IPv6 are enabled between PE and CE neighbors.

The Accept Own configuration works as follows:

1. CE1 originates prefix X.
2. Prefix X is installed in customer VRF as (RD1:X).
3. Prefix X is advertised to IntraAS-RR11 as (RD1:X, RT1).
4. IntraAS-RR11 advertises X to InterAS-RR1 as (RD1:X, RT1).
5. InterAS-RR1 attaches RT2 to prefix X on the inbound and ACCEPT_OWN community on the outbound and advertises prefix X to IntraAS-RR31.
6. IntraAS-RR31 advertises X to PE11.
7. PE11 installs X in Service VRF as (RD2:X,RT1, RT2, ACCEPT_OWN).

This example shows how to configure BGP Accept Own on a PE router.

```
router bgp 100
 neighbor 45.1.1.1
   remote-as 100
   update-source Loopback0
   address-family vpnv4 unicast
     route-policy pass-all in
     accept-own
     route-policy drop_111.x.x.x out
   !
   address-family vpnv6 unicast
     route-policy pass-all in
     accept-own
     route-policy drop_111.x.x.x out
   !
 !
```

This example shows an InterAS-RR configuration for BGP Accept Own.

```
router bgp 100
 neighbor 45.1.1.1
   remote-as 100
   update-source Loopback0
   address-family vpnv4 unicast
     route-policy rt_stitch1 in
     route-reflector-client
     route-policy add_bgp_ao out
   !
   address-family vpnv6 unicast
     route-policy rt_stitch1 in
     route-reflector-client
     route-policy add_bgp_ao out
   !
 !
 extcommunity-set rt cs_100:1
   100:1
 end-set
 !
 extcommunity-set rt cs_1001:1
   1001:1
 end-set
 !
```

```
route-policy rt_stitch1
  if extcommunity rt matches-any cs_100:1 then
    set extcommunity rt cs_1000:1 additive
  endif
end-policy
!
route-policy add_bgp_ao
  set community (accept-own) additive
end-policy
!
```

BGP Link-State

BGP Link-State (LS) is an Address Family Identifier (AFI) and Sub-address Family Identifier (SAFI) originally defined to carry interior gateway protocol (IGP) link-state information through BGP. The BGP Network Layer Reachability Information (NLRI) encoding format for BGP-LS and a new BGP Path Attribute called the BGP-LS attribute are defined in [RFC7752](#). The identifying key of each Link-State object, namely a node, link, or prefix, is encoded in the NLRI and the properties of the object are encoded in the BGP-LS attribute.



Note IGP does not use BGP LS data from remote peers. BGP does not download the received BGP LS data to any other component on the router.

An example of a BGP-LS application is the Segment Routing Path Computation Element (SR-PCE). The SR-PCE can learn the SR capabilities of the nodes in the topology and the mapping of SR segments to those nodes. This can enable the SR-PCE to perform path computations based on SR-TE and to steer traffic on paths different from the underlying IGP-based distributed best-path computation.

The following figure shows a typical deployment scenario. In each IGP area, one or more nodes (BGP speakers) are configured with BGP-LS. These BGP speakers form an iBGP mesh by connecting to one or more route-reflectors. This way, all BGP speakers (specifically the route-reflectors) obtain Link-State information from all IGP areas (and from other ASes from eBGP peers).

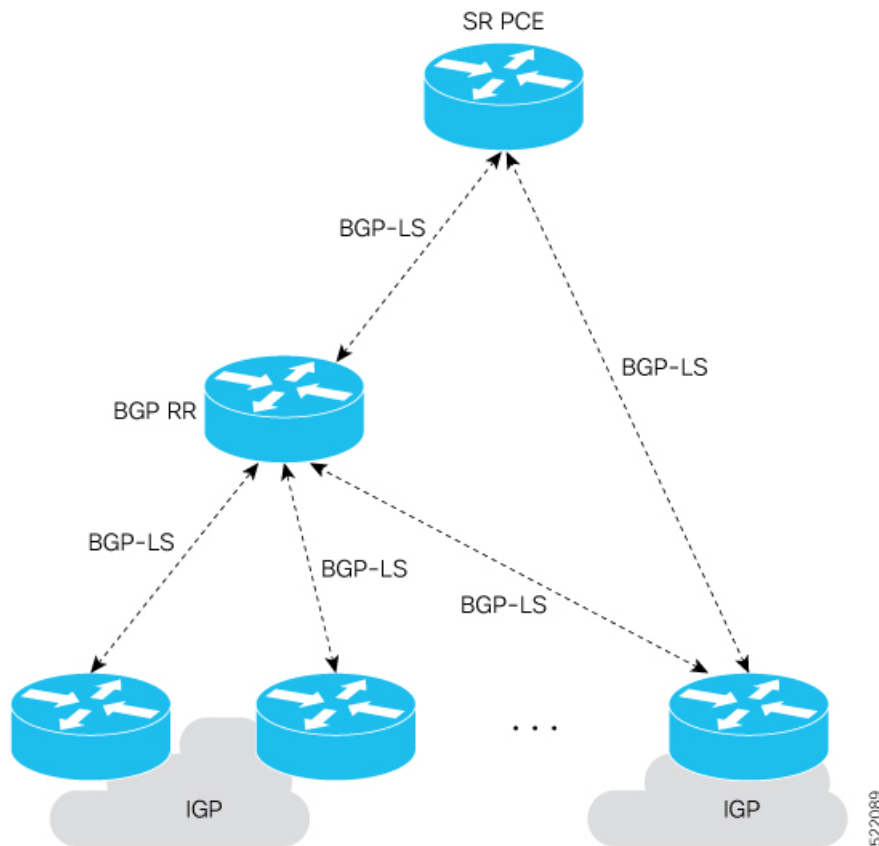

Exchange Link State Information with BGP Neighbor

The following example shows how to exchange link-state information with a BGP neighbor:

```
Router# configure
Router(config)# router bgp 1
Router(config-bgp)# neighbor 10.0.0.2
Router(config-bgp-nbr)# remote-as 1
Router(config-bgp-nbr)# address-family link-state link-state
Router(config-bgp-nbr-af)# exit
```

IGP Link-State Database Distribution

A given BGP node may have connections to multiple, independent routing domains. IGP link-state database distribution into BGP-LS is supported for both OSPF and IS-IS protocols in order to distribute this information on to controllers or applications that desire to build paths spanning or including these multiple domains.

To distribute OSPFv2 link-state data using BGP-LS, use the **distribute link-state** command in router configuration mode.

```
Router# configure
Router(config)# router ospf 100
Router(config-ospf)# distribute link-state instance-id 32
```

Usage Guidelines and Limitations

- BGP-LS supports IS-IS and OSPFv2.
- The identifier field of BGP-LS (referred to as the Instance-ID) identifies the IGP routing domain where the NLRI belongs. The NLRIs representing link-state objects (nodes, links, or prefixes) from the same IGP routing instance must use the same Instance-ID value.
- When there is only a single protocol instance in the network where BGP-LS is operational, we recommend configuring the Instance-ID value to **0**.
- Assign consistent BGP-LS Instance-ID values on all BGP-LS Producers within a given IGP domain.
- NLRIs with different Instance-ID values are considered to be from different IGP routing instances.
- Unique Instance-ID values must be assigned to routing protocol instances operating in different IGP domains. This allows the BGP-LS Consumer (for example, SR-PCE) to build an accurate segregated multi-domain topology based on the Instance-ID values, even when the topology is advertised via BGP-LS by multiple BGP-LS Producers in the network.
- If the BGP-LS Instance-ID configuration guidelines are not followed, a BGP-LS Consumer may see duplicate link-state objects for the same node, link, or prefix when there are multiple BGP-LS Producers deployed. This may also result in the BGP-LS Consumers getting an inaccurate network-wide topology.
- The following table defines the supported extensions to the BGP-LS address family for carrying IGP topology information (including SR information) via BGP. For more information on the BGP-LS TLVs, refer to [Border Gateway Protocol - Link State \(BGP-LS\) Parameters](#).

Table 9: IOS XR Supported BGP-LS Node Descriptor, Link Descriptor, Prefix Descriptor, and Attribute TLVs

TLV Code Point	Description	Produced by IS-IS	Produced by OSPFv2	Produced by BGP
256	Local Node Descriptors	X	X	—
257	Remote Node Descriptors	X	X	—
258	Link Local/Remote Identifiers	X	X	—
259	IPv4 interface address	X	X	—
260	IPv4 neighbor address	X		
261	IPv6 interface address	X	—	—
262	IPv6 neighbor address	X	—	—
263	Multi-Topology ID	X	—	—
264	OSPF Route Type	—	X	—
265	IP Reachability Information	X	X	—
266	Node MSD TLV	X	X	—
267	Link MSD TLV	X	X	—
512	Autonomous System	—	—	X
513	BGP-LS Identifier	—	—	X

TLV Code Point	Description	Produced by IS-IS	Produced by OSPFv2	Produced by BGP
514	OSPF Area-ID	—	X	—
515	IGP Router-ID	X	X	—
516	BGP Router-ID TLV	—	—	X
517	BGP Confederation Member TLV	—	—	X
1024	Node Flag Bits	X	X	—
1026	Node Name	X	X	—
1027	IS-IS Area Identifier	X	—	—
1028	IPv4 Router-ID of Local Node	X	X	—
1029	IPv6 Router-ID of Local Node	X	—	—
1030	IPv4 Router-ID of Remote Node	X	X	—
1031	IPv6 Router-ID of Remote Node	X	—	—
1034	SR Capabilities TLV	X	X	—
1035	SR Algorithm TLV	X	X	—
1036	SR Local Block TLV	X	X	—
1039	Flex Algo Definition (FAD) TLV	X	X	—
1044	Flex Algorithm Prefix Metric (FAPM) TLV	X	X	—
1088	Administrative group (color)	X	X	—
1089	Maximum link bandwidth	X	X	—
1090	Max. reservable link bandwidth	X	X	—
1091	Unreserved bandwidth	X	X	—
1092	TE Default Metric	X	X	—
1093	Link Protection Type	X	X	—
1094	MPLS Protocol Mask	X	X	—
1095	IGP Metric	X	X	—
1096	Shared Risk Link Group	X	X	—
1099	Adjacency SID TLV	X	X	—
1100	LAN Adjacency SID TLV	X	X	—
1101	PeerNode SID TLV	—	—	X
1102	PeerAdj SID TLV	—	—	X
1103	PeerSet SID TLV	—	—	X
1114	Unidirectional Link Delay TLV	X	X	—

TLV Code Point	Description	Produced by IS-IS	Produced by OSPFv2	Produced by BGP
1115	Min/Max Unidirectional Link Delay TLV	X	X	—
1116	Unidirectional Delay Variation TLV	X	X	—
1117	Unidirectional Link Loss	X	X	—
1118	Unidirectional Residual Bandwidth	X	X	—
1119	Unidirectional Available Bandwidth	X	X	—
1120	Unidirectional Utilized Bandwidth	X	X	—
1122	Application-Specific Link Attribute TLV	X	X	—
1152	IGP Flags	X	X	—
1153	IGP Route Tag	X	X	—
1154	IGP Extended Route Tag	X	—	—
1155	Prefix Metric	X	X	—
1156	OSPF Forwarding Address	—	X	—
1158	Prefix-SID	X	X	—
1159	Range	X	X	—
1161	SID/Label TLV	X	X	—
1170	Prefix Attribute Flags	X	X	—
1171	Source Router Identifier	X	—	—
1172	L2 Bundle Member Attributes TLV	X	—	—
1173	Extended Administrative Group	X	X	—

Configure BGP Link-state

To exchange BGP link-state (LS) information with a BGP neighbor, perform these steps:

SUMMARY STEPS

1. **configure**
2. **router bgp** *as-number*
3. **address-family link-state link-state**
4. **neighbor** *ip-address*
5. **remote-as** *as-number*
6. **address-family link-state link-state**
7. Use the **commit** or **end** command.

DETAILED STEPS

Step 1 **configure**

Example:

```
RP/0/RP0/CPU0:router# configure
```

Enters global configuration mode.

Step 2 **router bgp** *as-number***Example:**

```
RP/0/RP0/CPU0:router(config)# router bgp 100
```

Specifies the BGP AS number and enters the BGP configuration mode, allowing you to configure the BGP routing process.

Step 3 **address-family link-state link-state****Example:**

```
RP/0/RP0/CPU0:router(config-bgp-nbr)# address-family link-state link-state
```

Distributes BGP link-state information to the specified neighbor.

Step 4 **neighbor** *ip-address***Example:**

```
RP/0/RP0/CPU0:router(config-bgp)# neighbor 10.0.0.2
```

Configures a CE neighbor. The ip-address argument must be a private address.

Step 5 **remote-as** *as-number***Example:**

```
RP/0/RP0/CPU0:router(config-bgp-nbr)# remote-as 1
```

Configures the remote AS for the CE neighbor.

Step 6 **address-family link-state link-state****Example:**

```
RP/0/RP0/CPU0:router(config-bgp-nbr)# address-family link-state link-state
```

Distributes BGP link-state information to the specified neighbor.

Step 7 Use the **commit** or **end** command.

commit —Saves the configuration changes and remains within the configuration session.

end —Prompts user to take one of these actions:

- **Yes** — Saves configuration changes and exits the configuration session.
- **No** —Exits the configuration session without committing the configuration changes.

- **Cancel**—Remains in the configuration session, without committing the configuration changes.

Example

```
router bgp 100
 address-family link-state link-state
 !
 neighbor 10.0.0.2
  remote-as 1
  address-family link-state link-state
```

Configure Domain Distinguisher

To configure unique identifier four-octet ASN, perform these steps:

SUMMARY STEPS

1. **configure**
2. **router bgp** *as-number*
3. **address-family link-state link-state**
4. **domain-distinguisher** *unique-id*
5. Use the **commit** or **end** command.

DETAILED STEPS

Step 1 **configure**

Example:

```
RP/0/RP0/CPU0:router# configure
Enters global configuration mode.
```

Step 2 **router bgp** *as-number*

Example:

```
RP/0/RP0/CPU0:router(config)# router bgp 100
```

Specifies the BGP AS number and enters the BGP configuration mode, allowing you to configure the BGP routing process.

Step 3 **address-family link-state link-state**

Example:

```
RP/0/RP0/CPU0:router(config-bgp)# address-family link-state link-state
```

Enters address-family link-state configuration mode.

Step 4 **domain-distinguisher** *unique-id*

Example:

```
RP/0/RP0/CPU0:router(config-bgp-af)# domain-distinguisher 1234:1.2.3.4
```

Configures unique identifier four-octet ASN. Range is from 1 to 4294967295.

Step 5 Use the **commit** or **end** command.

commit —Saves the configuration changes and remains within the configuration session.

end —Prompts user to take one of these actions:

- **Yes** — Saves configuration changes and exits the configuration session.
- **No** —Exits the configuration session without committing the configuration changes.
- **Cancel** —Remains in the configuration session, without committing the configuration changes.

BGP Permanent Network

BGP permanent network feature supports static routing through BGP. BGP routes to IPv4 or IPv6 destinations (identified by a route-policy) can be administratively created and selectively advertised to BGP peers. These routes remain in the routing table until they are administratively removed. A permanent network is used to define a set of prefixes as permanent, that is, there is only one BGP advertisement or withdrawal in upstream for a set of prefixes. For each network in the prefix-set, a BGP permanent path is created and treated as less preferred than the other BGP paths received from its peer. The BGP permanent path is downloaded into RIB when it is the best-path.

The **permanent-network** command in global address family configuration mode uses a route-policy to identify the set of prefixes (networks) for which permanent paths is to be configured. The **advertise permanent-network** command in neighbor address-family configuration mode is used to identify the peers to whom the permanent paths must be advertised. The permanent paths is always advertised to peers having the advertise permanent-network configuration, even if a different best-path is available. The permanent path is not advertised to peers that are not configured to receive permanent path.

The permanent network feature supports only prefixes in IPv4 unicast and IPv6 unicast address-families under the default Virtual Routing and Forwarding (VRF).

Restrictions

These restrictions apply while configuring the permanent network:

- Permanent network prefixes must be specified by the route-policy on the global address family.
- You must configure the permanent network with route-policy in global address family configuration mode and then configure it on the neighbor address family configuration mode.
- When removing the permanent network configuration, remove the configuration in the neighbor address family configuration mode and then remove it from the global address family configuration mode.

Configure BGP Permanent Network

Perform this task to configure BGP permanent network. You must configure at least one route-policy to identify the set of prefixes (networks) for which the permanent network (path) is to be configured.

SUMMARY STEPS

1. **configure**
2. **prefix-set** *prefix-set-name*
3. **exit**
4. **route-policy** *route-policy-name*
5. **end-policy**
6. **router bgp** *as-number*
7. **address-family** { **ipv4** | **ipv6** } **unicast**
8. **permanent-network** **route-policy** *route-policy-name*
9. Use the **commit** or **end** command.
10. **show bgp** {**ipv4** | **ipv6**} **unicast** *prefix-set*

DETAILED STEPS

Step 1 **configure**

Example:

```
RP/0/RP0/CPU0:router# configure
Enters global configuration mode.
```

Step 2 **prefix-set** *prefix-set-name*

Example:

```
RP/0/RP0/CPU0:router(config)# prefix-set PERMANENT-NETWORK-IPv4
RP/0/RP0/CPU0:router(config-pfx)# 1.1.1.1/32,
RP/0/RP0/CPU0:router(config-pfx)# 2.2.2.2/32,
RP/0/RP0/CPU0:router(config-pfx)# 3.3.3.3/32
RP/0/RP0/CPU0:router(config-pfx)# end-set
```

Enters prefix set configuration mode and defines a prefix set for contiguous and non-contiguous set of bits.

Step 3 **exit**

Example:

```
RP/0/RP0/CPU0:router(config-pfx)# exit
```

Exits prefix set configuration mode and enters global configuration mode.

Step 4 **route-policy** *route-policy-name*

Example:

```
RP/0/RP0/CPU0:router(config)# route-policy POLICY-PERMANENT-NETWORK-IPv4
```

```
RP/0/RP0/CPU0:router(config-rpl)# if destination in PERMANENT-NETWORK-IPv4 then
RP/0/RP0/CPU0:router(config-rpl)# pass
RP/0/RP0/CPU0:router(config-rpl)# endif
```

Creates a route policy and enters route policy configuration mode, where you can define the route policy.

Step 5 **end-policy**

Example:

```
RP/0/RP0/CPU0:router(config-rpl)# end-policy
```

Ends the definition of a route policy and exits route policy configuration mode.

Step 6 **router bgp** *as-number*

Example:

```
RP/0/RP0/CPU0:router(config)# router bgp 100
```

Specifies the autonomous system number and enters the BGP configuration mode.

Step 7 **address-family** { *ipv4* | *ipv6* } **unicast**

Example:

```
RP/0/RP0/CPU0:router(config-bgp)# address-family ipv4 unicast
```

Specifies either an IPv4 or IPv6 address family unicast and enters address family configuration submode.

Step 8 **permanent-network** **route-policy** *route-policy-name*

Example:

```
RP/0/RP0/CPU0:router(config-bgp-af)# permanent-network route-policy POLICY-PERMANENT-NETWORK-IPv4
```

Configures the permanent network (path) for the set of prefixes as defined in the route-policy.

Step 9 Use the **commit** or **end** command.

commit —Saves the configuration changes and remains within the configuration session.

end —Prompts user to take one of these actions:

- **Yes** — Saves configuration changes and exits the configuration session.
- **No** —Exits the configuration session without committing the configuration changes.
- **Cancel** —Remains in the configuration session, without committing the configuration changes.

Step 10 **show bgp** { *ipv4* | *ipv6* } **unicast** *prefix-set*

Example:

```
RP/0/RP0/CPU0:router#show bgp ipv4 unicast
```

(Optional) Displays whether the prefix-set is a permanent network in BGP.

Advertise Permanent Network

Perform this task to identify the peers to whom the permanent paths must be advertised.

SUMMARY STEPS

1. **configure**
2. **router bgp** *as-number*
3. **neighbor** *ip-address*
4. **remote-as** *as-number*
5. **address-family** { **ipv4** | **ipv6** } **unicast**
6. **advertise permanent-network**
7. Use the **commit** or **end** command.
8. **show bgp** {**ipv4** | **ipv6**} **unicast neighbor** *ip-address*

DETAILED STEPS

Step 1 **configure**

Example:

```
RP/0/RP0/CPU0:router# configure
Enters global configuration mode.
```

Step 2 **router bgp** *as-number*

Example:

```
RP/0/RP0/CPU0:router(config)# router bgp 100
```

Specifies the autonomous system number and enters the BGP configuration mode.

Step 3 **neighbor** *ip-address*

Example:

```
RP/0/RP0/CPU0:router(config-bgp)# neighbor 10.255.255.254
```

Places the router in neighbor configuration mode for BGP routing and configures the neighbor IP address as a BGP peer.

Step 4 **remote-as** *as-number*

Example:

```
RP/0/RP0/CPU0:router(config-bgp-nbr)# remote-as 4713
```

Assigns the neighbor a remote autonomous system number.

Step 5 `address-family { ipv4 | ipv6 } unicast`**Example:**

```
RP/0/RP0/CPU0:router(config-bgp-nbr)# address-family ipv4 unicast
```

Specifies either an IPv4 or IPv6 address family unicast and enters address family configuration submode.

Step 6 `advertise permanent-network`**Example:**

```
RP/0/RP0/CPU0:router(config-bgp-nbr-af)# advertise permanent-network
```

Specifies the peers to whom the permanent network (path) is advertised.

Step 7 Use the `commit` or `end` command.

commit —Saves the configuration changes and remains within the configuration session.

end —Prompts user to take one of these actions:

- **Yes** — Saves configuration changes and exits the configuration session.
- **No** —Exits the configuration session without committing the configuration changes.
- **Cancel** —Remains in the configuration session, without committing the configuration changes.

Step 8 `show bgp { ipv4 | ipv6 } unicast neighbor ip-address`**Example:**

```
RP/0/RP0/CPU0:routershow bgp ipv4 unicast neighbor 10.255.255.254
```

(Optional) Displays whether the neighbor is capable of receiving BGP permanent networks.

Enable BGP Unequal Cost Recursive Load Balancing

SUMMARY STEPS

1. `configure`
2. `router bgp as-number`
3. `address-family { ipv4 | ipv6 } unicast`
4. `maximum-paths { ebgp | ibgp | eibgp } maximum [unequal-cost]`
5. `exit`
6. `neighbor ip-address`
7. `dmz-link-bandwidth`
8. Use the `commit` or `end` command.

DETAILED STEPS

	Command or Action	Purpose
Step 1	configure Example: RP/0/RP0/CPU0:router# configure	Enters global configuration mode.
Step 2	router bgp <i>as-number</i> Example: RP/0/RP0/CPU0:router(config)# router bgp 120	Specifies the autonomous system number and enters the BGP configuration mode, allowing you to configure the BGP routing process.
Step 3	address-family { ipv4 ipv6 } unicast Example: RP/0/RP0/CPU0:router(config-bgp)# address-family ipv4 unicast	Specifies either an IPv4 or IPv6 address family unicast and enters address family configuration submode. To see a list of all the possible keywords and arguments for this command, use the CLI help (?).
Step 4	maximum-paths { ebgp ibgp eibgp } maximum [unequal-cost] Example: RP/0/RP0/CPU0:router(config-bgp-af)# maximum-paths ebgp 3	Configures the maximum number of parallel routes that BGP installs in the routing table. <ul style="list-style-type: none"> • ebgp maximum : Consider only eBGP paths for multipath. • ibgp maximum [unequal-cost]: Consider load balancing between iBGP learned paths. • eibgp maximum : Consider both eBGP and iBGP learned paths for load balancing. eiBGP load balancing always does unequal-cost load balancing. When eiBGP is applied, eBGP or iBGP load balancing cannot be configured; however, eBGP and iBGP load balancing can coexist.
Step 5	exit Example: RP/0/RP0/CPU0:router(config-bgp-af)# exit	Exits the current configuration mode.
Step 6	neighbor <i>ip-address</i> Example: RP/0/RP0/CPU0:router(config-bgp)# neighbor 10.0.0.0	Configures a CE neighbor. The <i>ip-address</i> argument must be a private address.
Step 7	dmz-link-bandwidth Example: RP/0/RP0/CPU0:router(config-bgp-nbr)# dmz-link-bandwidth	Originates a demilitarized-zone (DMZ) link-bandwidth extended community for the link to an eBGP/iBGP neighbor.

	Command or Action	Purpose
Step 8	Use the commit or end command.	<p>commit —Saves the configuration changes and remains within the configuration session.</p> <p>end —Prompts user to take one of these actions:</p> <ul style="list-style-type: none"> • Yes — Saves configuration changes and exits the configuration session. • No —Exits the configuration session without committing the configuration changes. • Cancel —Remains in the configuration session, without committing the configuration changes.

BGP Unequal Cost Recursive Load Balancing: Example

This is a sample configuration for unequal cost recursive load balancing:

```

interface Loopback0
  ipv4 address 20.20.20.20 255.255.255.255
  !
interface MgmtEth0/RSP0/CPU0/0
  ipv4 address 8.43.0.10 255.255.255.0
  !
interface TenGigE0/3/0/0
  bandwidth 8000000
  ipv4 address 11.11.11.11 255.255.255.0
  ipv6 address 11:11:0:1::11/64
  !
interface TenGigE0/3/0/1
  bandwidth 7000000
  ipv4 address 11.11.12.11 255.255.255.0
  ipv6 address 11:11:0:2::11/64
  !
interface TenGigE0/3/0/2
  bandwidth 6000000
  ipv4 address 11.11.13.11 255.255.255.0
  ipv6 address 11:11:0:3::11/64
  !
interface TenGigE0/3/0/3
  bandwidth 5000000
  ipv4 address 11.11.14.11 255.255.255.0
  ipv6 address 11:11:0:4::11/64
  !
interface TenGigE0/3/0/4
  bandwidth 4000000
  ipv4 address 11.11.15.11 255.255.255.0
  ipv6 address 11:11:0:5::11/64
  !
interface TenGigE0/3/0/5
  bandwidth 3000000
  ipv4 address 11.11.16.11 255.255.255.0
  ipv6 address 11:11:0:6::11/64
  !
interface TenGigE0/3/0/6
  bandwidth 2000000

```

```
    ipv4 address 11.11.17.11 255.255.255.0
    ipv6 address 11:11:0:7::11/64
!
interface TenGigE0/3/0/7
  bandwidth 1000000
  ipv4 address 11.11.18.11 255.255.255.0
  ipv6 address 11:11:0:8::11/64
!
interface TenGigE0/4/0/0
  description CONNECTED TO IXIA 1/3
  transceiver permit pid all
!
interface TenGigE0/4/0/2
  ipv4 address 9.9.9.9 255.255.0.0
  ipv6 address 9:9::9/64
  ipv6 enable
!
route-policy pass-all
  pass
end-policy
!
router static
  address-family ipv4 unicast
    202.153.144.0/24 8.43.0.1
  !
!
router bgp 100
  bgp router-id 20.20.20.20
  address-family ipv4 unicast
    maximum-paths eibgp 8
    redistribute connected
  !
  neighbor 11.11.11.12
    remote-as 200
    dmz-link-bandwidth
    address-family ipv4 unicast
      route-policy pass-all in
      route-policy pass-all out
    !
  !
  neighbor 11.11.12.12
    remote-as 200
    dmz-link-bandwidth
    address-family ipv4 unicast
      route-policy pass-all in
      route-policy pass-all out
    !
  !
  neighbor 11.11.13.12
    remote-as 200
    dmz-link-bandwidth
    address-family ipv4 unicast
      route-policy pass-all in
      route-policy pass-all out
    !
  !
  neighbor 11.11.14.12
    remote-as 200
    dmz-link-bandwidth
    address-family ipv4 unicast
      route-policy pass-all in
      route-policy pass-all out
    !
  !
!
```

```

neighbor 11.11.15.12
  remote-as 200
  dmz-link-bandwidth
  address-family ipv4 unicast
    route-policy pass-all in
    route-policy pass-all out
  !
!
neighbor 11.11.16.12
  remote-as 200
  dmz-link-bandwidth
  address-family ipv4 unicast
    route-policy pass-all in
    route-policy pass-all out
  !
!
neighbor 11.11.17.12
  remote-as 200
  dmz-link-bandwidth
  address-family ipv4 unicast
    route-policy pass-all in
    route-policy pass-all out
  !
!
neighbor 11.11.18.12
  remote-as 200
  dmz-link-bandwidth
  address-family ipv4 unicast
    route-policy pass-all in
    route-policy pass-all out
  !
!
end

```

DMZ Link Bandwidth for Unequal Cost Recursive Load Balancing

The demilitarized zone (DMZ) link bandwidth for unequal cost recursive load balancing feature provides support for unequal cost load balancing for recursive prefixes on local node using DMZ link bandwidth. Use the `dmz-link-bandwidth` command in BGP neighbor configuration mode and the `bandwidth` command in interface configuration mode to The unequal load balance is achieved.

When the PE router includes the link bandwidth extended community in its updates to the remote PE through the Multiprotocol Interior BGP (MP-iBGP) session (either IPv4 or VPNv4), the remote PE automatically does load balancing if the **maximum-paths** command is enabled.



Note Unequal cost recursive load balancing happens across maximum eight paths only.

Enable BGP Unequal Cost Recursive Load Balancing

SUMMARY STEPS

1. **configure**
2. **router bgp** *as-number*
3. **address-family** { **ipv4** | **ipv6** } **unicast**
4. **maximum-paths** { **ebgp** | **ibgp** | **eibgp** } *maximum* [**unequal-cost**]

5. **exit**
6. **neighbor** *ip-address*
7. **dmz-link-bandwidth**
8. Use the **commit** or **end** command.

DETAILED STEPS

	Command or Action	Purpose
Step 1	configure Example: RP/0/RP0/CPU0:router# configure	Enters global configuration mode.
Step 2	router bgp <i>as-number</i> Example: RP/0/RP0/CPU0:router(config)# router bgp 120	Specifies the autonomous system number and enters the BGP configuration mode, allowing you to configure the BGP routing process.
Step 3	address-family { ipv4 ipv6 } unicast Example: RP/0/RP0/CPU0:router(config-bgp)# address-family ipv4 unicast	Specifies either an IPv4 or IPv6 address family unicast and enters address family configuration submenu. To see a list of all the possible keywords and arguments for this command, use the CLI help (?).
Step 4	maximum-paths { ebgp ibgp eibgp } <i>maximum</i> [unequal-cost] Example: RP/0/RP0/CPU0:router(config-bgp-af)# maximum-paths ebgp 3	Configures the maximum number of parallel routes that BGP installs in the routing table. <ul style="list-style-type: none"> • ebgp <i>maximum</i> : Consider only eBGP paths for multipath. • ibgp <i>maximum</i> [unequal-cost]: Consider load balancing between iBGP learned paths. • eibgp <i>maximum</i> : Consider both eBGP and iBGP learned paths for load balancing. eiBGP load balancing always does unequal-cost load balancing. When eiBGP is applied, eBGP or iBGP load balancing cannot be configured; however, eBGP and iBGP load balancing can coexist.
Step 5	exit Example: RP/0/RP0/CPU0:router(config-bgp-af)# exit	Exits the current configuration mode.
Step 6	neighbor <i>ip-address</i> Example: RP/0/RP0/CPU0:router(config-bgp)# neighbor 10.0.0.0	Configures a CE neighbor. The <i>ip-address</i> argument must be a private address.

	Command or Action	Purpose
Step 7	dmz-link-bandwidth Example: <pre>RP/0/RP0/CPU0:router(config-bgp-nbr)# dmz-link-bandwidth</pre>	Originates a demilitarized-zone (DMZ) link-bandwidth extended community for the link to an eBGP/iBGP neighbor.
Step 8	Use the commit or end command.	commit —Saves the configuration changes and remains within the configuration session. end —Prompts user to take one of these actions: <ul style="list-style-type: none"> • Yes — Saves configuration changes and exits the configuration session. • No —Exits the configuration session without committing the configuration changes. • Cancel —Remains in the configuration session, without committing the configuration changes.

BGP Unequal Cost Recursive Load Balancing: Example

This is a sample configuration for unequal cost recursive load balancing:

```
interface Loopback0
  ipv4 address 20.20.20.20 255.255.255.255
  !
interface MgmtEth0/RSP0/CPU0/0
  ipv4 address 8.43.0.10 255.255.255.0
  !
interface TenGigE0/3/0/0
  bandwidth 8000000
  ipv4 address 11.11.11.11 255.255.255.0
  ipv6 address 11:11:0:1::11/64
  !
interface TenGigE0/3/0/1
  bandwidth 7000000
  ipv4 address 11.11.12.11 255.255.255.0
  ipv6 address 11:11:0:2::11/64
  !
interface TenGigE0/3/0/2
  bandwidth 6000000
  ipv4 address 11.11.13.11 255.255.255.0
  ipv6 address 11:11:0:3::11/64
  !
interface TenGigE0/3/0/3
  bandwidth 5000000
  ipv4 address 11.11.14.11 255.255.255.0
  ipv6 address 11:11:0:4::11/64
  !
interface TenGigE0/3/0/4
  bandwidth 4000000
  ipv4 address 11.11.15.11 255.255.255.0
  ipv6 address 11:11:0:5::11/64
  !
```

```
interface TenGigE0/3/0/5
  bandwidth 3000000
  ipv4 address 11.11.16.11 255.255.255.0
  ipv6 address 11:11:0:6::11/64
!
interface TenGigE0/3/0/6
  bandwidth 2000000
  ipv4 address 11.11.17.11 255.255.255.0
  ipv6 address 11:11:0:7::11/64
!
interface TenGigE0/3/0/7
  bandwidth 1000000
  ipv4 address 11.11.18.11 255.255.255.0
  ipv6 address 11:11:0:8::11/64
!
interface TenGigE0/4/0/0
  description CONNECTED TO IXIA 1/3
  transceiver permit pid all
!
interface TenGigE0/4/0/2
  ipv4 address 9.9.9.9 255.255.0.0
  ipv6 address 9:9::9/64
  ipv6 enable
!
route-policy pass-all
  pass
end-policy
!
router static
  address-family ipv4 unicast
    202.153.144.0/24 8.43.0.1
  !
!
router bgp 100
  bgp router-id 20.20.20.20
  address-family ipv4 unicast
    maximum-paths eibgp 8
    redistribute connected
  !
  neighbor 11.11.11.12
    remote-as 200
    dmz-link-bandwidth
    address-family ipv4 unicast
      route-policy pass-all in
      route-policy pass-all out
  !
!
  neighbor 11.11.12.12
    remote-as 200
    dmz-link-bandwidth
    address-family ipv4 unicast
      route-policy pass-all in
      route-policy pass-all out
  !
!
  neighbor 11.11.13.12
    remote-as 200
    dmz-link-bandwidth
    address-family ipv4 unicast
      route-policy pass-all in
      route-policy pass-all out
  !
!
  neighbor 11.11.14.12
```

```

remote-as 200
dmz-link-bandwidth
address-family ipv4 unicast
route-policy pass-all in
route-policy pass-all out
!
!
neighbor 11.11.15.12
remote-as 200
dmz-link-bandwidth
address-family ipv4 unicast
route-policy pass-all in
route-policy pass-all out
!
!
neighbor 11.11.16.12
remote-as 200
dmz-link-bandwidth
address-family ipv4 unicast
route-policy pass-all in
route-policy pass-all out
!
!
neighbor 11.11.17.12
remote-as 200
dmz-link-bandwidth
address-family ipv4 unicast
route-policy pass-all in
route-policy pass-all out
!
!
neighbor 11.11.18.12
remote-as 200
dmz-link-bandwidth
address-family ipv4 unicast
route-policy pass-all in
route-policy pass-all out
!
!
end

```

DMZ Link Bandwidth Over EBGP Peer

The demilitarized zone (DMZ) link bandwidth extended community is an optional non-transitive attribute; therefore, it is not advertised to eBGP peers by default but it is advertised only to iBGP peers. This extended community is meant for load balancing over multi-paths. However, Cisco IOS-XR enables advertising of the DMZ link bandwidth to an eBGP peer, or receiving the DMZ link bandwidth by an eBGP peer. This feature also gives the user the option to send the bandwidth unchanged, or take the accumulated bandwidth over all the egress links and advertise that to the upstream eBGP peer.

Use the **ebgp-send-community-dmz** command to send the community to eBGP peers. By default, the link bandwidth extended-community attribute associated with the best path is sent.

When the **cumulative** keyword is used, the value of the link bandwidth extended community is set to the sum of link bandwidth values of all the egress-multipaths. If the DMZ link bandwidth value of the multipaths is unknown, for instance, some paths do not have that attribute, then unequal cost load-balancing is not done at that node. However, the sum of the known DMZ link bandwidth values is calculated and sent to the eBGP peer.

Use the **ebgp-recv-community-dmz** command to receive the community from eBGP peers.



Note The `ebgp-send-community-dmz` and `ebgp-recv-community-dmz` commands can be configured in the `neighbor`, `neighbour-group`, and `session-group` configuration mode.

Use the `bgp bestpath as-path multipath-relax` and `bgp bestpath as-path ignore` commands to handle multipath across different autonomous systems.

Sending and Receiving DMZ Link Bandwidth Extended Community over eBGP Peer

SUMMARY STEPS

1. `configure`
2. `router bgp as-number`
3. `neighbor ip-address`
4. `ebgp-send-extcommunity-dmz ip-address`
5. `exit`
6. `neighbor ip-address`
7. `ebgp-recv-extcommunity-dmz`
8. `exit`

DETAILED STEPS

Step 1 `configure`

Example:

```
RP/0/RP0/CPU0:router# configure
Enters global configuration mode.
```

Step 2 `router bgp as-number`

Example:

```
RP/0/RP0/CPU0:router(config)# router bgp 100
Specifies the autonomous system number and enters the BGP configuration mode, allowing you to configure the BGP routing process.
```

Step 3 `neighbor ip-address`

Example:

```
RP/0/RP0/CPU0:router(config-bgp)# neighbor 10.1.1.1
Enters the neighbor configuration mode for configuring BGP routing sessions.
```

Step 4 `ebgp-send-extcommunity-dmz ip-address`

Example:

```
RP/0/RP0/CPU0:router(config-bgp)# ebgp-send-extcommunity-dmz
Sends the DMZ link bandwidth extended community to the eBGP neighbor.
```

Note Use the **cumulative** keyword with this command to set the value of the link bandwidth extended community to the sum of link bandwidth values of all the egress multipaths.

Step 5 **exit**

Example:

```
RP/0/RP0/CPU0:router(config-bgp-nbr)# exit
```

Exits the neighbor configuration mode and enters into BGP configuration mode.

Step 6 **neighbor ip-address**

Example:

```
RP/0/RP0/CPU0:router(config-bgp)# neighbor 172.16.0.1
```

Enters the neighbor configuration mode for configuring BGP routing sessions.

Step 7 **ebgp-recv-extcommunity-dmz**

Example:

```
RP/0/RP0/CPU0:router(config-bgp-nbr)# ebgp-recv-extcommunity-dmz
```

Receives the DMZ link bandwidth extended community to the eBGP neighbor.

Step 8 **exit**

Example:

```
RP/0/RP0/CPU0:router(config-bgp-nbr)# exit
```

Exits the neighbor configuration mode and enters into BGP configuration mode.

DMZ Link Bandwidth: Example

The following examples shows how Router R1 sends DMZ link bandwidth extended communities to Router R2 over eBGP peer connection:

```
R1: sending router
-----
neighbour 10.3.3.3
  remote-as 2
  ebgp-send-extcommunity-dmz
  address-family ipv4 unicast
  route-policy pass in
  route-policy pass out
  !
```

```
R2: Receiving router
-----
neighbor 192.0.2.1
  remote-as 3
  ebgp-recv-extcommunity-dmz
  address-family ipv4 unicast
  route-policy pass in
  !
route-policy pass out
```

!

The following is a sample configuration that displays the DMZ link bandwidth configuration in the sending (R1) router:

```
RP/0/RP0/CPU0:router) # show bgp ipv4 unicast 10.1.1.1/32 detail

Path #1: Received by speaker 0
  Flags: 0x4000000001040003, import: 0x20
  Advertised to update-groups (with more than one peer):
    0.4
  Advertised to peers (in unique update groups):
    20.0.0.1
  3
  11.1.0.2 from 11.1.0.2 (11.1.0.2)
    Origin incomplete, metric 20, localpref 100, valid, external, best, group-best
    Received Path ID 0, Local Path ID 0, version 21
    Extended community: LB:3:192
    Origin-AS validity: not-found
```

The following is a sample configuration that displays DMZ link bandwidth configuration in the receiving (R2) router:

```
RP/0/RP0/CPU0:router) # show bgp ipv4 unicast 10.1.1.1/32 detail

Paths: (1 available, best #1)
  Not advertised to any peer
  Path #1: Received by speaker 0
  Not advertised to any peer
  1 3
  20.0.0.2 from 20.0.0.2 (10.0.0.81)
    Origin incomplete, localpref 100, valid, external, best, group-best
    Received Path ID 0, Local Path ID 0, version 17
    Extended community: LB:1:192
    Origin-AS validity: not-found
```

BGP Prefix Origin Validation using RPKI

A BGP route associates an address prefix with a set of autonomous systems (AS) that identify the interdomain path the prefix has traversed in the form of BGP announcements. This set is represented as the AS_PATH attribute in BGP and starts with the AS that originated the prefix.

To help reduce well-known threats against BGP including prefix mis-announcing and monkey-in-the-middle attacks, one of the security requirements is the ability to validate the origination AS of BGP routes. The AS number claiming to originate an address prefix (as derived from the AS_PATH attribute of the BGP route) needs to be verified and authorized by the prefix holder.

The Resource Public Key Infrastructure (RPKI) is an approach to build a formally verifiable database of IP addresses and AS numbers as resources. The RPKI is a globally distributed database containing, among other things, information mapping BGP (internet) prefixes to their authorized origin-AS numbers. Routers running BGP can connect to the RPKI to validate the origin-AS of BGP paths.

Configure RPKI Cache-server

Perform this task to configure Resource Public Key Infrastructure (RPKI) cache-server parameters.

Configure the RPKI cache-server parameters in rpki-server configuration mode. Use the **rpki server** command in router BGP configuration mode to enter into the rpki-server configuration mode

SUMMARY STEPS

1. **configure**
2. **router bgp** *as-number*
3. **rpki cache** {*host-name* | *ip-address*}
4. Use one of these commands:
 - **transport ssh port** *port_number*
 - **transport tcp port** *port_number*
5. (Optional) **username** *user_name*
6. (Optional) **password**
7. **preference** *preference_value*
8. **purge-time** *time*
9. Use one of these commands.
 - **refresh-time** *time*
 - **refresh-time off**
10. Use one these commands.
 - **response-time** *time*
 - **response-time off**
11. **shutdown**
12. Use the **commit** or **end** command.

DETAILED STEPS

Step 1 **configure**

Example:

```
RP/0/RP0/CPU0:router# configure
Enters global configuration mode.
```

Step 2 **router bgp** *as-number*

Example:

```
RP/0/RP0/CPU0:router(config)#router bgp 100
```

Specifies the BGP AS number and enters the BGP configuration mode, allowing you to configure the BGP routing process.

Step 3 **rpki cache** {*host-name* | *ip-address*}

Example:

```
RP/0/RP0/CPU0:router(config-bgp)#rpki server 10.2.3.4
```

Enters rpki-server configuration mode and enables configuration of RPKI cache parameters.

Step 4 Use one of these commands:

- **transport ssh port** *port_number*
- **transport tcp port** *port_number*

Example:

```
RP/0/RP0/CPU0:router(config-bgp-rpki-server)#transport ssh port 22
```

Or

```
RP/0/RP0/CPU0:router(config-bgp-rpki-server)#transport tcp port 2
```

Specifies a transport method for the RPKI cache.

- **ssh**—Select **ssh** to connect to the RPKI cache using SSH.
- **tcp**—Select **tcp** to connect to the RPKI cache using TCP (unencrypted).
- **port** *port_number*—Specify the port number for the RPKI cache transport over TCP and SSH protocols. The port number ranges from 1 to 65535.

Note

- SSH supports custom ports in addition to the default port number 22.
- You can set the transport to either TCP or SSH. Change of transport causes the cache session to flap.

Step 5 (Optional) **username** *user_name*

Example:

```
RP/0/RP0/CPU0:router(config-bgp-rpki-server)#username ssh_rpki_cache
```

Specifies a (SSH) username for the RPKI cache-server.

Step 6 (Optional) **password**

Example:

```
RP/0/RP0/CPU0:router(config-bgp-rpki-server)#password ssh_rpki_pass
```

Specifies a (SSH) password for the RPKI cache-server.

Note

The “username” and “password” configurations only apply if the SSH method of transport is active.

Step 7 **preference** *preference_value*

Example:

```
RP/0/RP0/CPU0:router(config-bgp-rpki-server)#preference 1
```

Specifies a preference value for the RPKI cache. Range for the preference value is 1 to 10. Setting a lower preference value is better.

Step 8 **purge-time** *time*

Example:

```
RP/0/RP0/CPU0:router(config-bgp-rpki-server)#purge-time 30
```

Configures the time BGP waits to keep routes from a cache after the cache session drops. Set purge time in seconds. Range for the purge time is 30 to 360 seconds.

Step 9 Use one of these commands.

- **refresh-time** *time*

- **refresh-time off**

Example:

```
RP/0/RP0/CPU0:router(config-bgp-rpki-server)#refresh-time 20
```

Or

```
RP/0/RP0/CPU0:router(config-bgp-rpki-server)#refresh-time off
```

Configures the time BGP waits in between sending periodic serial queries to the cache. Set refresh-time in seconds. Range for the refresh time is 15 to 3600 seconds.

Configure the **off** option to specify not to send serial-queries periodically.

Step 10

Use one these commands.

- **response-time time**
- **response-time off**

Example:

```
RP/0/RP0/CPU0:router(config-bgp-rpki-server)#response-time 30
```

Or

```
RP/0/RP0/CPU0:router(config-bgp-rpki-server)#response-time off
```

Configures the time BGP waits for a response after sending a serial or reset query. Set response-time in seconds. Range for the response time is 15 to 3600 seconds.

Configure the **off** option to wait indefinitely for a response.

Step 11**shutdown****Example:**

```
RP/0/RP0/CPU0:router(config-bgp-rpki-server)#shutdown
```

Configures shut down of the RPKI cache.

Step 12

Use the **commit** or **end** command.

commit —Saves the configuration changes and remains within the configuration session.

end —Prompts user to take one of these actions:

- **Yes** — Saves configuration changes and exits the configuration session.
- **No** —Exits the configuration session without committing the configuration changes.
- **Cancel** —Remains in the configuration session, without committing the configuration changes.

Configure BGP Prefix Validation

Starting from Release 6.5.1, RPKI is disabled by default. From Release 6.5.1, use the following task to configure RPKI Prefix Validation.

```
Router(config)# router bgp 100
/* The bgp origin-as validation time and bgp origin-as validity signal ibgp commands are optional. */
Router(config-bgp)# bgp origin-as validation time 50
Router(config-bgp)# bgp origin-as validation time off
```

```
Router(config-bgp)# bgp origin-as validation signal ibgp
Router(config-bgp)# address-family ipv4 unicast
Router(config-bgp-af)# bgp origin-as validation enable
```

Use the following commands to verify the origin-as validation configuration:

```
Router# show bgp origin-as validity

Thu Mar 14 04:18:09.656 PDT
BGP router identifier 10.1.1.1, local AS number 1
BGP generic scan interval 60 secs
Non-stop routing is enabled
BGP table state: Active
Table ID: 0xe0000000 RD version: 514
BGP main routing table version 514
BGP NSR Initial initsync version 2 (Reached)
BGP NSR/ISSU Sync-Group versions 0/0
BGP scan interval 60 secs
Status codes: s suppressed, d damped, h history, * valid, > best
                i - internal, r RIB-failure, S stale, N Nexthop-discard
Origin codes: i - IGP, e - EGP, ? - incomplete
Origin-AS validation codes: V valid, I invalid, N not-found, D disabled
   Network                Next Hop                Metric LocPrf Weight Path
 *> 209.165.200.223/27      0.0.0.0                0          32768 ?
 *> 209.165.200.225/27      0.0.0.0                0          32768 ?
 *> 19.1.2.0/24             0.0.0.0                0          32768 ?
 *> 19.1.3.0/24            0.0.0.0                0          32768 ?
 *> 10.1.2.0/24            0.0.0.0                0          32768 ?
 *> 10.1.3.0/24            0.0.0.0                0          32768 ?
 *> 10.1.4.0/24            0.0.0.0                0          32768 ?
 *> 198.51.100.1/24        0.0.0.0                0          32768 ?
 *> 203.0.113.235/24       0.0.0.0                0          32768 ?
V*> 209.165.201.0/27        10.1.2.1                0          4002 i
N*> 198.51.100.2/24        10.1.2.1                0          4002 i
I*> 198.51.100.1/24        10.1.2.1                0          4002 i
 *> 192.0.2.1.0/24         0.0.0.0                0          32768 ?

Router# show bgp process
Mon Jul 9 16:47:39.428 PDT

BGP Process Information:
...
Use origin-AS validity in bestpath decisions
Allow (origin-AS) INVALID paths
Signal origin-AS validity state to neighbors

Address family: IPv4 Unicast
...
Origin-AS validation is enabled for this address-family
Use origin-AS validity in bestpath decisions for this address-family
Allow (origin-AS) INVALID paths for this address-family
Signal origin-AS validity state to neighbors with this address-family
```

Configure RPKI Bestpath Computation

Perform this task to configure RPKI bestpath computation options.

SUMMARY STEPS

1. **configure**
2. **router bgp** *as-number*
3. **rpki bestpath use origin-as validity**
4. **rpki bestpath origin-as allow invalid**
5. Use the **commit** or **end** command.

DETAILED STEPS

Step 1 **configure****Example:**

```
RP/0/RP0/CPU0:router# configure
```

Enters global configuration mode.

Step 2 **router bgp** *as-number***Example:**

```
RP/0/RP0/CPU0:router(config)#router bgp 100
```

Specifies the BGP AS number and enters the BGP configuration mode, allowing you to configure the BGP routing process.

Step 3 **rpki bestpath use origin-as validity****Example:**

```
RP/0/RP0/CPU0:router(config-bgp)#rpki bestpath use origin-as validity
```

Enables the validity states of BGP paths to affect the path's preference in the BGP bestpath process. This configuration can also be done in router BGP address family submode.

Step 4 **rpki bestpath origin-as allow invalid****Example:**

```
RP/0/RP0/CPU0:router(config-bgp)#rpki bestpath origin-as allow invalid
```

Allows all "invalid" paths to be considered for BGP bestpath computation.

Note

This configuration can also be done at global address family, neighbor, and neighbor address family submodes. Configuring `rpki bestpath origin-as allow invalid` in router BGP and address family submodes allow all "invalid" paths to be considered for BGP bestpath computation. By default, all such paths are not bestpath candidates. Configuring `pki bestpath origin-as allow invalid` in neighbor and neighbor address family submodes allow all "invalid" paths from that specific neighbor or neighbor address family to be considered as bestpath candidates. The neighbor must be an eBGP neighbor.

This configuration takes effect only when the `rpki bestpath use origin-as validity` configuration is enabled.

Step 5 Use the **commit** or **end** command.

commit —Saves the configuration changes and remains within the configuration session.

end —Prompts user to take one of these actions:

- **Yes** — Saves configuration changes and exits the configuration session.
- **No** —Exits the configuration session without committing the configuration changes.
- **Cancel** —Remains in the configuration session, without committing the configuration changes.

Resilient Per-CE Label Allocation Mode

The Resilient Per-CE Label Allocation is an extension of the Per-CE label allocation mode to support Prefix Independent Convergence (PIC) and load balancing. At present, the three label allocation modes, Per-Prefix, Per-CE, and Per-VRF have these restrictions:

- No support for load balancing across CEs
- Temporary forwarding loop during local traffic diversion to support PIC
- No support for EIBGP multipath load balancing
- Forwarding performance impact

In the Resilient Per-CE label allocation scheme, BGP installs a unique rewrite label in LSD for every unique set of CE paths or next hops. There may be one or more prefixes in BGP table that points to this label. BGP also installs the CE paths (primary) and optionally a backup PE path into RIB. FIB learns about the label rewrite information from LSD and the IP paths from RIB. In steady state, labeled traffic destined to the resilient per-CE label is load balanced across all the CE next hops. When all the CE paths fail, any traffic destined to that label will result in an IP lookup and will be forwarded towards the backup PE path, if available. This action is performed on the label independently of the number of prefixes that may point to the label, resulting in the PIC behavior during primary paths failure.

Configure Resilient Per-CE Label Allocation Mode Under VRF Address Family

Perform this task to configure resilient per-ce label allocation mode under VRF address family.

SUMMARY STEPS

1. **configure**
2. **router bgpas-number**
3. **vrfvrf-instance**
4. **address-family {ipv4 | ipv6} unicast**
5. **label-mode per-ce**
6. Do one of the following:
 - **end**
 - **commit**

DETAILED STEPS

Step 1 **configure**

Example:

```
RP/0/RP0/CPU0:router# configure  
RP/0/RP0/CPU0:router(config)#
```

Enters global configuration mode.

Step 2 **router bgp***as-number*

Example:

```
RP/0/RP0/CPU0:router(config)# router bgp 666  
RP/0/RP0/CPU0:router(config-bgp)#
```

Specifies the autonomous system number and enters the BGP configuration mode, allowing you to configure the BGP routing process.

Step 3 **vrf***vrf-instance*

Example:

```
RP/0/RP0/CPU0:router(config-bgp)# vrf vrf-pe  
RP/0/RP0/CPU0:router(config-bgp-vrf)#
```

Configures a VRF instance.

Step 4 **address-family {ipv4 | ipv6} unicast**

Example:

```
RP/0/RP0/CPU0:router(config-bgp-vrf)# address-family ipv4 unicast  
RP/0/RP0/CPU0:router(config-bgp-vrf-af)#
```

Specifies either an IPv4 or IPv6 address family unicast and enters address family configuration submode.

Step 5 **label-mode per-ce**

Example:

```
RP/0/RP0/CPU0:router(config-bgp-vrf-af)# label mode per-ce  
RP/0/RP0/CPU0:router(config-bgp-vrf-af)#
```

Configures resilient per-ce label allocation mode.

Step 6 Do one of the following:

- **end**
- **commit**

Example:

```
RP/0/RP0/CPU0:router(config-bgp-vrf-af)# end
```

or

```
RP/0/RP0/CPU0:router(config-bgp-vrf-af)# commit
```

Saves configuration changes.

- When you issue the **end** command, the system prompts you to commit changes:

```
Uncommitted changes found, commit them before exiting(yes/no/cancel)?[cancel]:
```

- Entering **yes** saves configuration changes to the running configuration file, exits the configuration session, and returns the router to EXEC mode.
 - Entering **no** exits the configuration session and returns the router to EXEC mode without committing the configuration changes.
 - Entering **cancel** leaves the router in the current configuration session without exiting or committing the configuration changes.
- Use the **commit** command to save the configuration changes to the running configuration file and remain within the configuration session.

This example shows how to configure resilient per-ce label allocation mode under VRF address family:

```
RP/0/RP0/CPU0:router# configure
RP/0/RP0/CPU0:router(config)# router bgp 666
RP/0/RP0/CPU0:router(config-bgp)# vrf vrf-pe
RP/0/RP0/CPU0:router(config-bgp-vrf)# address-family ipv4 unicast
RP/0/RP0/CPU0:router(config-bgp-vrf-af)# label mode per-ce
RP/0/RP0/CPU0:router(config-bgp-vrf-af)# end
```

Configure Resilient Per-CE Label Allocation Mode Using Route-Policy

Perform this task to configure resilient per-ce label allocation mode using a route-policy.

SUMMARY STEPS

1. **configure**
2. **route-policy***policy-name*
3. **set label-mode per-ce**
4. Do one of the following:
 - **end**
 - **commit**

DETAILED STEPS

Step 1 **configure**

Example:

```
RP/0/RP0/CPU0:router# configure
RP/0/RP0/CPU0:router(config)#
```

Enters global configuration mode.

Step 2 **route-policy***policy-name*

Example:

```
RP/0/RP0/CPU0:router(config)# route-policy route1
RP/0/RP0/CPU0:router(config-rpl)#
```

Creates a route policy and enters route policy configuration mode.

Step 3 **set label-mode per-ce**

Example:

```
RP/0/RP0/CPU0:router(config-rpl)# set label-mode per-ce
RP/0/RP0/CPU0:router(config-rpl)#
```

Configures resilient per-ce label allocation mode.

Step 4 Do one of the following:

- **end**
- **commit**

Example:

```
RP/0/RP0/CPU0:router(config-rpl)# end
```

or

```
RP/0/RP0/CPU0:router(config-rpl)# commit
```

Saves configuration changes.

- When you issue the **end** command, the system prompts you to commit changes:

```
Uncommitted changes found, commit them before exiting(yes/no/cancel)?[cancel]:
```

- Entering **yes** saves configuration changes to the running configuration file, exits the configuration session, and returns the router to EXEC mode.
 - Entering **no** exits the configuration session and returns the router to EXEC mode without committing the configuration changes.
 - Entering **cancel** leaves the router in the current configuration session without exiting or committing the configuration changes.
- Use the **commit** command to save the configuration changes to the running configuration file and remain within the configuration session.

This example shows how to configure resilient per-ce label allocation mode using a route-policy:

```
RP/0/RP0/CPU0:router# configure
RP/0/RP0/CPU0:router(config)# route-policy route1
RP/0/RP0/CPU0:router(config-rpl)# set label-mode per-ce
RP/0/RP0/CPU0:router(config-rpl)# end
```

BGP VRF Dynamic Route Leaking

The Border Gateway Protocol (BGP) dynamic route leaking feature provides the ability to import routes between the default-vrf (Global VRF) and any other non-default VRF, to provide connectivity between a global and a VPN host. The import process installs the Internet route in a VRF table or a VRF route in the Internet table, providing connectivity.

The dynamic route leaking is enabled by:

- Importing from default-VRF to non-default-VRF, using the **import from default-vrf route-policy route-policy-name [advertise-as-vpn]** command in VRF address-family configuration mode.

If the **advertise-as-vpn** option is configured, the paths imported from the default-VRF to the non-default-VRF are advertised to the PEs as well as to the CEs. If the **advertise-as-vpn** option is not configured, the paths imported from the default-VRF to the non-default-VRF are not advertised to the PE. However, the paths are still advertised to the CEs.

- Importing from non-default-VRF to default VRF, using the **export to default-vrf route-policy route-policy-name** command in VRF address-family configuration mode.

A route-policy is mandatory to filter the imported routes. This reduces the risk of unintended import of routes between the Internet table and the VRF tables and the corresponding security issues. There is no hard limit on the number of prefixes that can be imported. The import creates a new prefix in the destination VRF, which increases the total number of prefixes and paths. However, each VRF importing global routes adds workload equivalent to a neighbor receiving the global table. This is true even if the user filters out all but a few prefixes. Hence, importing five to ten VRFs is ideal.

Configure VRF Dynamic Route Leaking

Perform these steps to import routes from default-VRF to non-default VRF or to import routes from non-default VRF to default VRF.

Before you begin

A route-policy is mandatory for configuring dynamic route leaking. Use the **route-policy route-policy-name** command in global configuration mode to configure a route-policy.

SUMMARY STEPS

1. **configure**
2. **vrf vrf_name**
3. **address-family {ipv4 | ipv6} unicast**
4. Use one of these options:
 - **import from default-vrf route-policy route-policy-name [advertise-as-vpn]**
 - **export to default-vrf route-policy route-policy-name**
5. Use the **commit** or **end** command.

DETAILED STEPS

Step 1 **configure**

Example:

```
RP/0/RP0/CPU0:router# configure
```

Enters global configuration mode.

Step 2 **vrf vrf_name**

Example:

```
RP/0/RP0/CPU0:PE51_ASR-9010(config)#vrf vrf_1
```

Enters VRF configuration mode.

Step 3 **address-family {ipv4 | ipv6} unicast**

Example:

```
RP/0/RP0/CPU0:router(config-vrf)#address-family ipv6 unicast
```

Enters VRF address-family configuration mode.

Step 4 Use one of these options:

- **import from default-vrf route-policy route-policy-name [advertise-as-vpn]**
- **export to default-vrf route-policy route-policy-name**

Example:

```
RP/0/RP0/CPU0:router(config-vrf-af)#import from default-vrf route-policy rpl_dynamic_route_import
```

or

```
RP/0/RP0/CPU0:router(config-vrf-af)#export to default-vrf route-policy rpl_dynamic_route_export
```

Imports routes from default-VRF to non-default VRF or from non-default VRF to default-VRF.

- **import from default-vrf**—configures import from default-VRF to non-default-VRF.

If the **advertise-as-vpn** option is configured, the paths imported from the default-VRF to the non-default-VRF are advertised to the PEs as well as to the CEs. If the **advertise-as-vpn** option is not configured, the paths imported from the default-VRF to the non-default-VRF are not advertised to the PE. However, the paths are still advertised to the CEs.

- **export to default-vrf**—configures import from non-default-VRF to default VRF. The paths imported from the default-VRF are advertised to other PEs.

Step 5 Use the **commit** or **end** command.

commit —Saves the configuration changes and remains within the configuration session.

end —Prompts user to take one of these actions:

- **Yes** — Saves configuration changes and exits the configuration session.
- **No** —Exits the configuration session without committing the configuration changes.

- **Cancel**—Remains in the configuration session, without committing the configuration changes.

VRF Dynamic Route Leaking Configuration: Example

Import Routes from default-VRF to non-default-VRF:

```
vrf vrf_1
  address-family ipv6 unicast
    import from default-vrf route-policy rpl_dynamic_route_import
  !
end
```

Import Routes from non-default-VRF to default-VRF

```
vrf vrf_1
  address-family ipv6 unicast
    export to default-vrf route-policy rpl_dynamic_route_export
  !
end
```

What to do next

These **show bgp** command output displays information from the dynamic route leaking configuration:

- Use the **show bgp prefix** command to display the source-RD and the source-VRF for imported paths, including the cases when IPv4 or IPv6 unicast prefixes have imported paths.
- Use the **show bgp imported-routes** command to display IPv4 unicast and IPv6 unicast address-families under the default-VRF.

Configuring a VPN Routing and Forwarding Instance in BGP

Layer 3 (virtual private network) VPN can be configured only if there is an available Layer 3 VPN license for the line card slot on which the feature is being configured. If advanced IP license is enabled, 4096 Layer 3 VPN routing and forwarding instances (VRFs) can be configured on an interface. If the infrastructure VRF license is enabled, eight Layer 3 VRFs can be configured on the line card.

The following error message appears if the appropriate licence is not enabled:

```
RP/0/RP0/CPU0:router#LC/0/0/CPU0:Dec 15 17:57:53.653 : rsi_agent[247]:
%LICENSE-ASR9K_LICENSE-2-INFRA_VRF_NEEDED : 5 VRF(s) are configured without license
A9K-iVRF-LIC in violation of the Software Right To Use Agreement.
This feature may be disabled by the system without the appropriate license.
Contact Cisco to purchase the license immediately to avoid potential service interruption.
```



Note An AIP license is not required for configuring L2VPN services.

The following tasks are used to configure a VPN routing and forwarding (VRF) instance in BGP:

Define Virtual Routing and Forwarding Tables in Provider Edge Routers

Perform this task to define the VPN routing and forwarding (VRF) tables in the provider edge (PE) routers.

SUMMARY STEPS

1. **configure**
2. **vrf** *vrf-name*
3. **address-family** { **ipv4** | **ipv6** } **unicast**
4. **maximum prefix** *maximum* [*threshold*]
5. **import route-policy** *policy-name*
6. **import route-target** [*as-number : nn* | *ip-address : nn*]
7. **export route-policy** *policy-name*
8. **export route-target** [*as-number : nn* | *ip-address : nn*]
9. Use the **commit** or **end** command.

DETAILED STEPS

Step 1 **configure**

Example:

```
RP/0/RP0/CPU0:router# configure
```

Enters global configuration mode.

Step 2 **vrf** *vrf-name*

Example:

```
RP/0/RP0/CPU0:router(config)# vrf vrf_pe
```

Configures a VRF instance.

Step 3 **address-family** { **ipv4** | **ipv6** } **unicast**

Example:

```
RP/0/RP0/CPU0:router(config-vrf)# address-family ipv4 unicast
```

Specifies either the IPv4 or IPv6 address family and enters address family configuration submenu.

To see a list of all the possible keywords and arguments for this command, use the CLI help (?).

Step 4 **maximum prefix** *maximum* [*threshold*]

Example:

```
RP/0/RP0/CPU0:router(config-vrf-af)# maximum prefix 2300
```

Configures a limit to the number of prefixes allowed in a VRF table.

A maximum number of routes is applicable to dynamic routing protocols as well as static or connected routes.

You can specify a threshold percentage of the prefix limit using the *mid-threshold* argument.

Step 5 `import route-policy policy-name`**Example:**

```
RP/0/RP0/CPU0:router(config-vrf-af)# import route-policy policy_a
```

(Optional) Provides finer control over what gets imported into a VRF. This import filter discards prefixes that do not match the specified *policy-name* argument.

Step 6 `import route-target [as-number : nn | ip-address : nn]`**Example:**

```
RP/0/RP0/CPU0:router(config-vrf-af)# import route-target 234:222
```

Specifies a list of route target (RT) extended communities. Only prefixes that are associated with the specified import route target extended communities are imported into the VRF.

Step 7 `export route-policy policy-name`**Example:**

```
RP/0/RP0/CPU0:router(config-vrf-af)# export route-policy policy_b
```

(Optional) Provides finer control over what gets exported into a VRF. This export filter discards prefixes that do not match the specified *policy-name* argument.

Step 8 `export route-target [as-number : nn | ip-address : nn]`**Example:**

```
RP/0/RP0/CPU0:router(config-vrf-af)# export route-target 123:234
```

Specifies a list of route target extended communities. Export route target communities are associated with prefixes when they are advertised to remote PEs. The remote PEs import them into VRFs which have import RTs that match these exported route target communities.

Step 9 Use the **commit** or **end** command.

commit —Saves the configuration changes and remains within the configuration session.

end —Prompts user to take one of these actions:

- **Yes** — Saves configuration changes and exits the configuration session.
- **No** —Exits the configuration session without committing the configuration changes.
- **Cancel** —Remains in the configuration session, without committing the configuration changes.

Configure Route Distinguisher

The route distinguisher (RD) makes prefixes unique across multiple VPN routing and forwarding (VRF) instances.

In the L3VPN multipath same route distinguisher (RD) environment, the determination of whether to install a prefix in RIB or not is based on the prefix's bestpath. In a rare misconfiguration situation, where the best path is not a valid path to be installed in RIB, BGP drops the prefix and does not consider the other paths. The

behavior is different for different RD setup, where the non-best multipath will be installed if the best multipath is invalid to be installed in RIB.

Perform this task to configure the RD.

SUMMARY STEPS

1. **configure**
2. **router bgp** *as-number*
3. **bgp router-id** *ip-address*
4. **vrf** *vrf-name*
5. **rd** { *as-number : nn* | *ip-address : nn* | **auto** }
6. Do one of the following:
 - **end**
 - **commit**

DETAILED STEPS

Step 1 **configure**

Example:

```
RP/0/RP0/CPU0:router# configure
```

Enters global configuration mode.

Step 2 **router bgp** *as-number*

Example:

```
RP/0/RP0/CPU0:router(config)# router bgp 120
```

Enters BGP configuration mode allowing you to configure the BGP routing process.

Step 3 **bgp router-id** *ip-address*

Example:

```
RP/0/RP0/CPU0:router(config-bgp)# bgp router-id 10.0.0.0
```

Configures a fixed router ID for the BGP-speaking router.

Step 4 **vrf** *vrf-name*

Example:

```
RP/0/RP0/CPU0:router(config-bgp)# vrf vrf_pe
```

Configures a VRF instance.

Step 5 **rd** { *as-number : nn* | *ip-address : nn* | **auto** }

Example:

```
RP/0/RP0/CPU0:router(config-bgp-vrf)# rd 345:567
```

Configures the route distinguisher.

Use the **auto** keyword if you want the router to automatically assign a unique RD to the VRF.

Automatic assignment of RDs is possible only if a router ID is configured using the **bgp router-id** command in router configuration mode. This allows you to configure a globally unique router ID that can be used for automatic RD generation. The router ID for the VRF does not need to be globally unique, and using the VRF router ID would be incorrect for automatic RD generation. Having a single router ID also helps in checkpointing RD information for BGP graceful restart, because it is expected to be stable across reboots.

Step 6 Do one of the following:

- **end**
- **commit**

Example:

```
RP/0/RP0/CPU0:router(config-bgp-vrf)# end
```

or

```
RP/0/RP0/CPU0:router(config-bgp-vrf)# commit
```

Saves configuration changes.

- When you issue the **end** command, the system prompts you to commit changes:

```
Uncommitted changes found, commit them before exiting(yes/no/cancel)?[cancel]:
```

- Entering **yes** saves configuration changes to the running configuration file, exits the configuration session, and returns the router to XR EXEC mode.
 - Entering **no** exits the configuration session and returns the router to XR EXEC mode without committing the configuration changes.
 - Entering **cancel** leaves the router in the current configuration session without exiting or committing the configuration changes.
- Use the **commit** command to save the configuration changes to the running configuration file and remain within the configuration session.

Configure PE-PE or PE-RR Interior BGP Sessions

To enable BGP to carry VPN reachability information between provider edge (PE) routers you must configure the PE-PE interior BGP (iBGP) sessions. A PE uses VPN information carried from the remote PE router to determine VPN connectivity and the label value to be used so the remote (egress) router can demultiplex the packet to the correct VPN during packet forwarding.

The PE-PE, PE-route reflector (RR) iBGP sessions are defined to all PE and RR routers that participate in the VPNs configured in the PE router.

Perform this task to configure PE-PE iBGP sessions and to configure global VPN options on a PE.

SUMMARY STEPS

1. **configure**
2. **router bgp** *as-number*
3. **address-family** **vpn4 unicast**
4. **exit**
5. **neighbor** *ip-address*
6. **remote-as** *as-number*
7. **description** *text*
8. **password** { **clear** | **encrypted** } *password*
9. **shutdown**
10. **timers** *keepalive hold-time*
11. **update-source** *type interface-id*
12. **address-family** **vpn4 unicast**
13. **route-policy** *route-policy-name* **in**
14. **route-policy** *route-policy-name* **out**
15. Use the **commit** or **end** command.

DETAILED STEPS

Step 1 **configure**

Example:

```
RP/0/RP0/CPU0:router# configure
Enters global configuration mode.
```

Step 2 **router bgp** *as-number*

Example:

```
RP/0/RP0/CPU0:router(config)# router bgp 120
Specifies the autonomous system number and enters the BGP configuration mode, allowing you to configure the BGP routing process.
```

Step 3 **address-family** **vpn4 unicast**

Example:

```
RP/0/RP0/CPU0:router(config-bgp)# address-family vpn4 unicast
Enters VPN address family configuration mode.
```

Step 4 **exit**

Example:

```
RP/0/RP0/CPU0:router(config-bgp-af)# exit
Exits the current configuration mode.
```

Step 5 **neighbor** *ip-address*

Example:

```
RP/0/RP0/CPU0:router(config-bgp)# neighbor 172.16.1.1
```

Configures a PE iBGP neighbor.

Step 6 **remote-as** *as-number***Example:**

```
RP/0/RP0/CPU0:router(config-bgp-nbr)# remote-as 1
```

Assigns the neighbor a remote autonomous system number.

Step 7 **description** *text***Example:**

```
RP/0/RP0/CPU0:router(config-bgp-nbr)# description neighbor 172.16.1.1
```

(Optional) Provides a description of the neighbor. The description is used to save comments and does not affect software function.

Step 8 **password** { **clear** | **encrypted** } *password***Example:**

```
RP/0/RP0/CPU0:router(config-bgp-nbr)# password encrypted 123abc
```

Enables Message Digest 5 (MD5) authentication on the TCP connection between the two BGP neighbors.

Step 9 **shutdown****Example:**

```
RP/0/RP0/CPU0:router(config-bgp-nbr)# shutdown
```

Terminates any active sessions for the specified neighbor and removes all associated routing information.

Step 10 **timers** *keepalive hold-time***Example:**

```
RP/0/RP0/CPU0:router(config-bgp-nbr)# timers 12000 200
```

Set the timers for the BGP neighbor.

Step 11 **update-source** *type interface-id***Example:**

```
RP/0/RP0/CPU0:router(config-bgp-nbr)# update-source gigabitEthernet 0/1/5/0
```

Allows iBGP sessions to use the primary IP address from a specific interface as the local address when forming an iBGP session with a neighbor.

Step 12 **address-family** **vpnv4 unicast****Example:**

```
RP/0/RP0/CPU0:router(config-bgp-nbr)# address-family vpnv4 unicast
```

Enters VPN neighbor address family configuration mode.

Step 13 `route-policy route-policy-name in`

Example:

```
RP/0/RP0/CPU0:router(config-bgp-nbr-af)# route-policy pe-pe-vpn-in in
```

Specifies a routing policy for an inbound route. The policy can be used to filter routes or modify route attributes.

Step 14 `route-policy route-policy-name out`

Example:

```
RP/0/RP0/CPU0:router(config-bgp-nbr-af)# route-policy pe-pe-vpn-out out
```

Specifies a routing policy for an outbound route. The policy can be used to filter routes or modify route attributes.

Step 15 Use the `commit` or `end` command.

commit —Saves the configuration changes and remains within the configuration session.

end —Prompts user to take one of these actions:

- **Yes** — Saves configuration changes and exits the configuration session.
- **No** —Exits the configuration session without committing the configuration changes.
- **Cancel** —Remains in the configuration session, without committing the configuration changes.

Configure BGP as PE-CE Protocol

Perform this task to configure BGP on the PE and establish PE-CE communication using BGP.

SUMMARY STEPS

1. `configure`
2. `router bgp as-number`
3. `vrf vrf-name`
4. `bgp router-id ip-address`
5. `label-allocation-mode per-ce`
6. `address-family { ipv4 | ipv6 } unicast`
7. `network { ip-address / prefix-length | ip-address mask }`
8. `aggregate-address address / mask-length`
9. `exit`
10. `neighbor ip-address`
11. `remote-as as-number`
12. `password { clear | encrypted } password`
13. `ebgp-multihop [ttl-value]`
14. Do one of the following:
 - `address-family { ipv4 | ipv6 } unicast`
 - `address-family { ipv4 {unicast | labeled-unicast} | ipv6 unicast }`

15. **site-of-origin** [*as-number : nn* | *ip-address : nn*]
16. **as-override**
17. **allowas-in** [*as-occurrence-number*]
18. **route-policy** *route-policy-name* **in**
19. **route-policy** *route-policy-name* **out**
20. Use the **commit** or **end** command.

DETAILED STEPS

	Command or Action	Purpose
Step 1	configure Example: RP/0/RP0/CPU0:router# configure	Enters global configuration mode.
Step 2	router bgp <i>as-number</i> Example: RP/0/RP0/CPU0:router(config)# router bgp 120	Specifies the autonomous system number and enters the BGP configuration mode, allowing you to configure the BGP routing process.
Step 3	vrf <i>vrf-name</i> Example: RP/0/RP0/CPU0:router(config-bgp)# vrf vrf_pe_2	Enables BGP routing for a particular VRF on the PE router.
Step 4	bgp router-id <i>ip-address</i> Example: RP/0/RP0/CPU0:router(config-bgp-vrf)# bgp router-id 172.16.9.9	Configures a fixed router ID for a BGP-speaking router.
Step 5	label-allocation-mode per-ce Example: RP/0/RP0/CPU0:router(config-bgp-vrf)# label-allocation-mode per-ce	<ul style="list-style-type: none"> Configures The per-ce keyword configures the per-CE label allocation mode to avoid an extra lookup on the PE router and conserve label space (per-prefix is the default label allocation mode). In this mode, the PE router allocates one label for every immediate next-hop (in most cases, this would be a CE router). This label is directly mapped to the next hop, so there is no VRF route lookup performed during data forwarding. However, the number of labels allocated would be one for each CE rather than one for each VRF. Because BGP knows all the next hops, it assigns a label for each next hop (not for each PE-CE interface). When the outgoing interface is a multiaccess interface and the media access control (MAC) address of the neighbor is not known, Address Resolution Protocol (ARP) is triggered during packet forwarding.

	Command or Action	Purpose
		<ul style="list-style-type: none"> The per-vrf keyword configures the same label to be used for all the routes advertised from a unique VRF.
Step 6	address-family { ipv4 ipv6 } unicast Example: RP/0/RP0/CPU0:router(config-vrf)# address-family ipv4 unicast	Specifies either an IPv4 or IPv6 address family unicast and enters address family configuration submode. To see a list of all the possible keywords and arguments for this command, use the CLI help (?).
Step 7	network { <i>ip-address / prefix-length</i> <i>ip-address mask</i> } Example: RP/0/RP0/CPU0:router(config-bgp-vrf-af)# network 172.16.5.5	Originates a network prefix in the address family table in the VRF context.
Step 8	aggregate-address <i>address / mask-length</i> Example: RP/0/RP0/CPU0:router(config-bgp-vrf-af)# aggregate-address 10.0.0.0/24	Configures aggregation in the VRF address family context to summarize routing information to reduce the state maintained in the core. This summarization introduces some inefficiency in the PE edge, because an additional lookup is required to determine the ultimate next hop for a packet. When configured, a summary prefix is advertised instead of a set of component prefixes, which are more specifics of the aggregate. The PE advertises only one label for the aggregate. Because component prefixes could have different next hops to CEs, an additional lookup has to be performed during data forwarding.
Step 9	exit Example: RP/0/RP0/CPU0:router(config-bgp-vrf-af)# exit	Exits the current configuration mode.
Step 10	neighbor <i>ip-address</i> Example: RP/0/RP0/CPU0:router(config-bgp-vrf)# neighbor 10.0.0.0	Configures a CE neighbor. The <i>ip-address</i> argument must be a private address.
Step 11	remote-as <i>as-number</i> Example: RP/0/RP0/CPU0:router(config-bgp-vrf-nbr)# remote-as 2	Configures the remote AS for the CE neighbor.
Step 12	password { clear encrypted } <i>password</i> Example:	Enable Message Digest 5 (MD5) authentication on a TCP connection between two BGP neighbors.

	Command or Action	Purpose
	RP/0/RP0/CPU0:router (config-bgp-vrf-nbr) # password encrypted 234xyz	
Step 13	ebgp-multihop [<i>ttl-value</i>] Example: RP/0/RP0/CPU0:router (config-bgp-vrf-nbr) # ebgp-multihop 55	Configures the CE neighbor to accept and attempt BGP connections to external peers residing on networks that are not directly connected.
Step 14	Do one of the following: <ul style="list-style-type: none"> • address-family { <i>ipv4</i> <i>ipv6</i> } unicast • address-family { <i>ipv4</i> { unicast labeled-unicast } <i>ipv6 unicast</i> } Example: RP/0/RP0/CPU0:router (config-vrf) # address-family ipv4 unicast	Specifies either an IPv4 or IPv6 address family unicast and enters address family configuration submode. To see a list of all the possible keywords and arguments for this command, use the CLI help (?).
Step 15	site-of-origin [<i>as-number : nn</i> <i>ip-address : nn</i>] Example: RP/0/RP0/CPU0:router (config-bgp-vrf-nbr-af) # site-of-origin 234:111	Configures the site-of-origin (SoO) extended community. Routes that are learned from this CE neighbor are tagged with the SoO extended community before being advertised to the rest of the PEs. SoO is frequently used to detect loops when as-override is configured on the PE router. If the prefix is looped back to the same site, the PE detects this and does not send the update to the CE.
Step 16	as-override Example: RP/0/RP0/CPU0:router (config-bgp-vrf-nbr-af) # as-override	Configures AS override on the PE router. This causes the PE router to replace the CE's ASN with its own (PE) ASN. Note This loss of information could lead to routing loops; to avoid loops caused by as-override, use it in conjunction with site-of-origin.
Step 17	allowas-in [<i>as-occurrence-number</i>] Example: RP/0/RP0/CPU0:router (config-bgp-vrf-nbr-af) # allowas-in 5	Allows an AS path with the PE autonomous system number (ASN) a specified number of times. Hub and spoke VPN networks need the looping back of routing information to the HUB PE through the HUB CE. When this happens, due to the presence of the PE ASN, the looped-back information is dropped by the HUB PE. To avoid this, use the allowas-in command to allow prefixes even if they have the PEs ASN up to the specified number of times.
Step 18	route-policy <i>route-policy-name</i> in Example: RP/0/RP0/CPU0:router (config-bgp-vrf-nbr-af) # route-policy pe_ce_in_policy in	Specifies a routing policy for an inbound route. The policy can be used to filter routes or modify route attributes.

	Command or Action	Purpose
Step 19	route-policy <i>route-policy-name</i> out Example: <pre>RP/0/RP0/CPU0:router(config-bgp-vrf-nbr-af) # route-policy pe_ce_out_policy out</pre>	Specifies a routing policy for an outbound route. The policy can be used to filter routes or modify route attributes.
Step 20	Use the commit or end command.	commit —Saves the configuration changes and remains within the configuration session. end —Prompts user to take one of these actions: <ul style="list-style-type: none"> • Yes — Saves configuration changes and exits the configuration session. • No —Exits the configuration session without committing the configuration changes. • Cancel —Remains in the configuration session, without committing the configuration changes.

Resetting an eBGP Session Immediately Upon Link Failure

By default, if a link goes down, all BGP sessions of any directly adjacent external peers are immediately reset. Use the **bgp fast-external-fallover disable** command to disable automatic resetting. Turn the automatic reset back on using the **no bgp fast-external-fallover disable** command.

eBGP sessions flap when the node reaches 3500 eBGP sessions with BGP timer values set as 10 and 30. To support more than 3500 eBGP sessions, increase the packet rate by using the **lpts pifib hardware police location location-id** command. Following is a sample configuration to increase the eBGP sessions:

```
RP/0/RP0/CPU0:router#configure
RP/0/RP0/CPU0:router(config)#lpts pifib hardware police location 0/2/CPU0
RP/0/RP0/CPU0:router(config-pifib-policer-per-node)#flow bgp configured rate 4000
RP/0/RP0/CPU0:router(config-pifib-policer-per-node)#flow bgp known rate 4000
RP/0/RP0/CPU0:router(config-pifib-policer-per-node)#flow bgp default rate 4000
RP/0/RP0/CPU0:router(config-pifib-policer-per-node)#commit
```

Selective FIB Download

The NCS 5500 system supports LOW-FIB scale and HIGH-FIB scale (with external TCAM) line cards. The Selective FIB Download feature enables the combination of both these cards to be used in the same chassis. The Selective FIB Download feature permits filtering of routes on the LOW-FIB scale line cards. The filtering of routes is achieved by marking the routes “external-reach” using a BGP route policy. The match criteria used within the BGP policy are prefix values, community, as-path, next-hop, local-pref, MED, and so on.

This feature helps to maximize resources available and to improve routing scalability.

Functionality

By default, all routes are marked “internal-reach”. However, using a BGP route policy, users can classify the BGP routes “external-reach”.

The “external-reach” routes are programmed only in the HIGH-FIB scale line card, while internal routes (for example-IGP, external, connected, static, and BGP routes that are not marked “external”) are programmed in both HIGH-FIB and LOW-FIB scale line cards. Because the “external-reach” routes are not programmed in the LOW-FIB scale line card, we recommend that you do not to mix bundle members from the LOW-FIB Scale and HIGH-FIB scale line cards under the same bundle interface.

Content Server Access

In this scenario, a content server is connected to the HIGH-FIB scale line card and the core uplink network is hosted on the LOW-FIB scale line card:

- Traffic originating from the content server requires global address reachability. Therefore, the global internet routes and the internal network routes are programmed in the HIGH-FIB line card.
- The core uplink network that is hosted on the LOW-FIB scale line card requires reachability only to the internal network. Therefore, the global internet routes are not programmed in the hardware of the LOW-FIB scale line card.
- MPLS labels are programmed on both the HIGH-FIB scale and LOW-FIB scale line cards.

LER

Label Edge Router receives the complete FIB table, BGP-LU updates, and internal routes. Label Edge Router programs the entire FIB table and the BGP-LU updates are preloaded into the HIGH-FIB scale line card, while the internal routes are preloaded into the LOW-FIB scale line card.

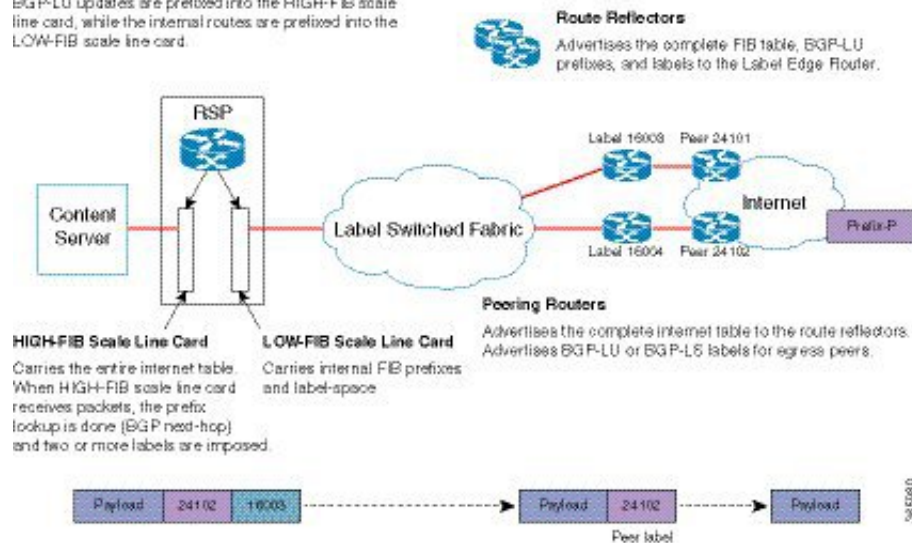

L3VPN Per-CE Mode

In this scenario, LOW-FIB scale line card is present in the core network and HIGH-FIB scale line card is present in the customer facing network. This combination of the LOW-FIB and HIGH-FIB scale line cards is used while operating in the per-CE VPN mode. In the per-CE mode, one label is assigned for every CE next-hop from which BGP learns the VRF routes. The packet flow in this mode is as follows:

- Imposition (Ingress) PE: A VRF-IP lookup on the HIGH-FIB line card is performed. After the lookup, the VPN label and transport label is pushed for disposition (egress) to the PE’s loopback address. In the core or the backbone network, a label switch is performed on the packet.
- Disposition (Egress) PE: The packet received from the core or the backbone network contains the VPN-label.

In the per-CE mode, the VPN-label is assigned per CE. The VPN-label lookup on the core facing line card (LOW-FIB scale line card) results in the next-hop to the HIGH-FIB line card, which is connected to the CE.

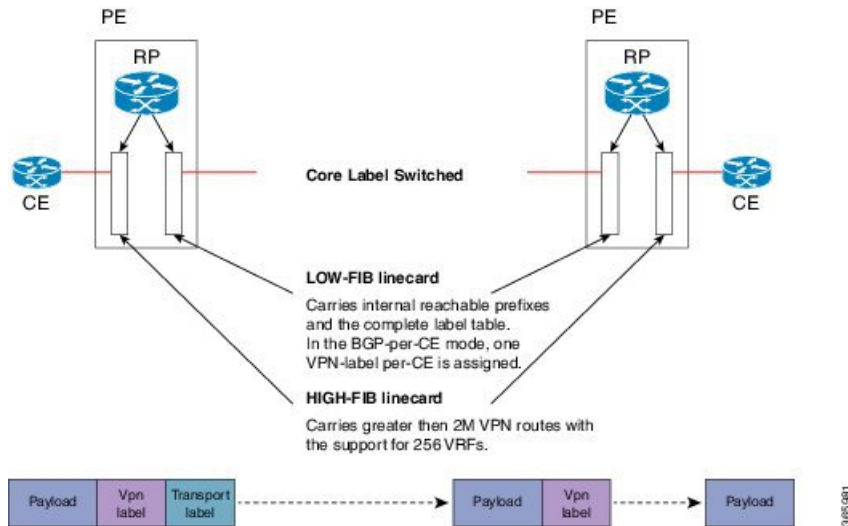

Note As explained in both the scenarios above, this solution does not affect forwarding performance. There is no packet redirection from LOW-FIB to HIGH-FIB scale card for route lookup. Therefore, if the HIGH-FIB card gets reset request or being reloaded, it does not affect the processing of the packet in LOW-FIB card.

Configuring Selective FIB Download

The following example shows how to configure selective FIB Download by marking the route “external-reach”:

```
Router#config
Router(config)#route-policy HIGHLOW_FIB
Router(config-rpl)#if destination in (150.0.0.0/8 le 24) then
Router(config-rpl-if)#set path-color external-reach
Router(config-rpl-if)#pass
Router(config-rpl-if)#else
Router(config-rpl-else)#pass
Router(config-rpl-else)#endif
Router(config-rpl)#end-policy
Router(config)#commit
Router(config)#end
```

Verification

To verify the “external-reach” attribute for routes, use the following commands:

- `show route prefix`
- `show cef prefix location location detail`
- `show controllers npu resources [all | encap | exttcamipv4 | exttcamipv6 | lem | lpm] location location`

```
*/Routing Information Base/*
Router#show route 150.0.2.0/24
```

```

Routing entry for 150.0.2.0/24
  Known via "bgp 100", distance 20, metric 0, external-reach-1c-only
  Tag 101, type external
  Installed Oct 13 05:28:46.750 for 00:01:08
  Routing Descriptor Blocks
    10.0.0.2, from 10.0.0.2, BGP external
    Route metric is 0
  No advertising protos.

*/Forwarding Information Base/*
Router#show cef 150.0.2.0/24 location 0/5/CPU0
150.0.2.0/24, version 1021523, external-reach-1c-only, internal 0x5000001 0x0 (ptr 0x88b012e8)
 [1], 0x0 (0x8a0fd598), 0x0 (0x0)
 Updated Oct 13 05:28:46.951
 Prefix Len 24, traffic index 0, precedence n/a, priority 4
   via 10.0.0.2/32, 5 dependencies, recursive, bgp-ext [flags 0x6020]
   path-idx 0 NHID 0x0 [0x88a54968 0x0]
   next hop 10.0.0.2/32 via 10.0.0.2/32

```

This command displays the count of routes programmed to the hardware.

```

Router#show controllers npu resources exttcamipv4 location 0/0/CPU0
HW Resource Information
  Name                               : ext_tcam_ipv4
OOR Information
  NPU-0
    Estimated Max Entries             : 2048000
    Red Threshold                     : 1945600
    Yellow Threshold                  : 1638400
    OOR State                         : Green

  NPU-1
    Estimated Max Entries             : 2048000
    Red Threshold                     : 1945600
    Yellow Threshold                  : 1638400
    OOR State                         : Green

  NPU-2
    Estimated Max Entries             : 2048000
    Red Threshold                     : 1945600
    Yellow Threshold                  : 1638400
    OOR State                         : Green

  NPU-3
    Estimated Max Entries             : 2048000
    Red Threshold                     : 1945600
    Yellow Threshold                  : 1638400
    OOR State                         : Green

Current Usage
  NPU-0
    Total In-Use                      : 1018789 (49 %)
    iproute                           : 1018789 (49 %) (Prefix Count: 1018789)
    ipmcroute                          : 0 (0 %) (Prefix Count: 0)

  NPU-1
    Total In-Use                      : 1018789 (49 %)
    iproute                           : 1018789 (49 %) (Prefix Count: 1018789)
    ipmcroute                          : 0 (0 %) (Prefix Count: 0)

  NPU-2
    Total In-Use                      : 1018789 (49 %)
    iproute                           : 1018789 (49 %) (Prefix Count: 1018789)
    ipmcroute                          : 0 (0 %) (Prefix Count: 0)

  NPU-3
    Total In-Use                      : 1018789 (49 %)

```

```

iproute          : 1018789  (49 %) (Prefix Count: 1018789)
ipmcroute        : 0        (0 %) (Prefix Count: 0)

```

Configuring BGP Large Communities

BGP communities provide a way to group destinations and apply routing decisions such as acceptance, rejection, preference, or redistribution on a group of destinations using community attributes. BGP community attributes are variable length attributes consisting of a set of one or more 4-byte values which are split into two parts of 16 bits. The higher-order 16 bits represents the AS number and the lower order bits represents a locally defined value assigned by the operator of the AS.

Since the adoption of 4-byte ASNs (RFC6793), the BGP communities attribute can no longer accommodate the 4 byte ASNs as you need more than 4 bytes to encode the 4-byte ASN and an AS specific value that you want to tag with the route. Although BGP extended community permits a 4-byte AS to be encoded as the global administrator field, the local administrator field has only 2-byte of available space. So, 6-byte extended community attribute is also unsuitable. To overcome this limitation, you can configure a 12-byte BGP large community which is an optional attribute that provides the most significant 4-byte value to encode autonomous system number as the global administrator and the remaining two 4-byte assigned numbers to encode the local values.

Similar to BGP communities, routers can apply BGP large communities to BGP routes by using route policy languages (RPL) and other routers can then perform actions based on the community that is attached to the route. The policy language provides sets as a container for groups of values for matching purposes.

When large communities are specified in other commands, they are specified as three non negative decimal integers separated by colons. For example, 1:2:3. Each integer is stored in 32 bits. The possible range for each integer is 0 to 4294967295.

In route-policy statements, each integer in the BGP large community can be replaced by any of the following expressions :

- [x..y] — This expression specifies a range between x and y, inclusive.
- * —This expression stands for any number.
- peeras — This expression is replaced by the AS number of the neighbor from which the community is received or to which the community is sent, as appropriate.
- not-peeras —This expression matches any number other than the peeras.
- private-as — This expression specifies any number in the private ASN range: [64512..65534] and [4200000000..4294967294].

These expressions can be also used in policy-match statements.

IOS regular expression (ios-regex) and DFA style regular expression (dfa-regex) can be used in any of the large-community policy match and delete statements. For example, the IOS regular expression ios-regex '^5:.*:7\$' is equivalent to the expression 5:*:7.

The **send-community-ebgp** command is extended to include BGP large communities. This command is required for the BGP speaker to send large communities to ebgp neighbors.

Restrictions and Guidelines

The following restrictions and guidelines apply for BGP large communities:

- All functionalities of the BGP community attribute is available for the BGP large-community attribute.

- The **send-community-ebgp** command is required for the BGP speaker to send large communities to ebgp neighbors.
- There are no well-known large-communities.
- The `peer-as` expression cannot be used in a `large-community-set`.
- The `peer-as` expression can only be used in `large-community match` or `delete` statements that appear in route policies that are applied at the `neighbor-in` or `neighbor-out` attach points.
- The `not-peer-as` expression cannot be used in a `large-community-set` or in policy set statements.

Configuration Example: Large Community Set

A large-community set defines a set of large communities. Named large-community sets are used in route-policy match and set statements.

This example shows how to create a named large-community set.

```
RP/0/RP0/CPU0:router(config)# large-community-set catbert
RP/0/RP0/CPU0:router(config-largecomm)# 1: 2: 3,
RP/0/RP0/CPU0:router(config-largecomm)# peer-as:2:3
RP/0/RP0/CPU0:router(config-largecomm)# end-set
```

Configuration Example: Set Large Community

The following example shows how to set the BGP large community attribute in a route, using the **set large-community** *{large-community-set-name | inline-large-community-set | parameter}* **[additive]** command. You can specify a named large-community-set or an inline set. The **additive** keyword retains the large communities already present in the route and adds the new set of large communities. However the **additive** keyword does not result in duplicate entries.

If a particular large community is attached to a route and you specify the same large community again with the additive keyword in the set statement, then the specified large community is not added again. The merging operation removes duplicate entries. This also applies to the `peer-as` keyword.

The `peer-as` expression in the example is replaced by the AS number of the neighbor from which the BGP large community is received or to which the community is sent, as appropriate.

```
RP/0/RP0/CPU0:router(config)# route-policy mordac
RP/0/RP0/CPU0:router(config-rpl)# set large-community (1:2:3, peer-as:2:3)
RP/0/RP0/CPU0:router(config-rpl)# end-set
RP/0/RP0/CPU0:router(config)# large-community-set catbert
RP/0/RP0/CPU0:router(config-largecomm)# 1: 2: 3,
RP/0/RP0/CPU0:router(config-largecomm)# peer-as:2:3
RP/0/RP0/CPU0:router(config-largecomm)# end-set
RP/0/RP0/CPU0:router(config)# route-policy wally
RP/0/RP0/CPU0:router(config-rpl)# set large-community catbert additive
RP/0/RP0/CPU0:router(config-rpl)# end-set
```

In this example, if the route-policy `mordac` is applied to a neighbor, the ASN of which is 1, then the large community (1:2:3) is set only once.



Note You should configure the **send-community-ebgp** command to send large communities to ebgp neighbors.

Configuration Example: Large Community Matches-any

The following example shows how to configure a route policy to match any element of a large -community set. This is a boolean condition and returns true if any of the large communities in the route match any of the large communities in the match condition.

```
RP/0/RP0/CPU0:router(config)# route-policy elbonia
RP/0/RP0/CPU0:router(config-rpl)# if large-community matches-any (1:2:3, 4:5:*) then
RP/0/RP0/CPU0:router(config-rpl)#   set local-preference 94
RP/0/RP0/CPU0:router(config-rpl)#   endif
RP/0/RP0/CPU0:router(config-rpl)# end-policy
```

Configuration Example: Large Community Matches-every

The following example shows how to configure a route policy where every match specification in the statement must be matched by at least one large community in the route.

```
RP/0/RP0/CPU0:router(config)# route-policy bob
RP/0/RP0/CPU0:router(config-rpl)# if large-community matches-every (*:3, 4:5:*) then
RP/0/RP0/CPU0:router(config-rpl)#   set local-preference 94
RP/0/RP0/CPU0:router(config-rpl)#   endif
RP/0/RP0/CPU0:router(config-rpl)# end-policy
```

In this example, routes with these sets of large communities return TRUE:

- (1:1:3, 4:5:10)
- (4:5:3) —This single large community matches both specifications.
- (1:1:3, 4:5:10, 7:6:5)

Routes with the following set of large communities return FALSE:

(1:1:3, 5:5:10)—The specification (4:5:*) is not matched.

Configuration Example: Large Community Matches-within

The following example shows how to configure a route policy to match within a large community set. This is similar to the **large-community matches-any** command but every large community in the route must match at least one match specification. Note that if the route has no large communities, then it matches.

```
RP/0/RP0/CPU0:router(config)# route-policy bob
RP/0/RP0/CPU0:router(config-rpl)# if large-community matches-within (*:3, 4:5:*) then
RP/0/RP0/CPU0:router(config-rpl)#   set local-preference 103
RP/0/RP0/CPU0:router(config-rpl)#   endif
RP/0/RP0/CPU0:router(config-rpl)# end-policy
```

For example, routes with these sets of large communities return TRUE:

- (1:1:3, 4:5:10)
- (4:5:3)
- (1:2:3, 6:6:3, 9:4:3)

Routes with this set of large communities return FALSE:

(1:1:3, 4:5:10, 7:6:5) —The large community (7:6:5) does not match

Configuration Example: Community Matches-within

The following example shows how to configure a route policy to match within the elements of a community set. This command is similar to the **community matches-any** command, but every community in the route must match at least one match specification. If the route has no communities, then it matches.

```
RP/0/RP0/CPU0:router(config)# route-policy bob
RP/0/RP0/CPU0:router(config-rpl)# if community matches-within (*:3, 5:*) then
RP/0/RP0/CPU0:router(config-rpl)#   set local-preference 94
RP/0/RP0/CPU0:router(config-rpl)# endif
RP/0/RP0/CPU0:router(config-rpl)# end-policy
```

For example, routes with these sets of communities return TRUE:

- (1:3, 5:10)
- (5:3)
- (2:3, 6:3, 4:3)

Routes with this set of communities return FALSE:

(1:3, 5:10, 6:5) —The community (6:5) does not match.

Configuration Example: Large Community Is-empty

The following example shows using the **large-community is-empty** clause to filter routes that do not have the large-community attribute set.

```
RP/0/RP0/CPU0:router(config)# route-policy lrg_comm_rp4
RP/0/RP0/CPU0:router(config-rpl)# if large-community is-empty then
RP/0/RP0/CPU0:router(config-rpl)#   set local-preference 104
RP/0/RP0/CPU0:router(config-rpl)# endif
RP/0/RP0/CPU0:router(config-rpl)# end-policy
```

Configuration Example: Attribute Filter Group

The following example shows how to configure and apply the attribute-filter group with large-community attributes for a BGP neighbor. The filter specifies the BGP path attributes and an action to take when BGP update message is received. If an update message is received from the BGP neighbor that contains any of the specified attributes, then the specified action is taken. In this example, the attribute filter named dogbert is created and applied to the BGP neighbor 10.0.1.101. It specifies the large community attribute and the action of discard. That means, if the large community BGP path attribute is received in a BGP UPDATE message from the neighbor 10.0.1.101 then the attribute will be discarded before further processing of the message.

```
RP/0/RP0/CPU0:router(config)# router bgp 100
RP/0/RP0/CPU0:router(config-bgp)# attribute-filter group dogbert
RP/0/RP0/CPU0:router(config-bgp-attrfg)# attribute LARGE-COMMUNITY discard
RP/0/RP0/CPU0:router(config-bgp-attrfg)# neighbor 10.0.1.101
RP/0/RP0/CPU0:router(config-bgp-nbr)# remote-as 6461
RP/0/RP0/CPU0:router(config-bgp-nbr)# update in filtering
RP/0/RP0/CPU0:router(config-nbr-upd-filter)# attribute-filter group dogbert
```

Configuration Example: Deleting Large Community

The following example shows how to delete specified BGP large-communities from a route policy using the **delete large-community** command.

```
RP/0/RP0/CPU0:router(config)# route-policy lrg_comm_rp2
RP/0/RP0/CPU0:router(config-rpl)# delete large-community in (ios-regex '^100000:')
RP/0/RP0/CPU0:router(config-rpl)# delete large-community all
RP/0/RP0/CPU0:router(config-rpl)# delete large-community not in (peeras:*:, 41289:*:*)
```

Verification

This example displays the routes with large-communities given in the **show bgp large-community list-of-large-communities [exact-match]** command. If the optional keyword **exact-match** is used, then the listed routes will contain only the specified large communities. Otherwise, the displayed routes may contain additional large communities.

```
RP/0/0/CPU0:R1# show bgp large-community 1:2:3 5:6:7
Thu Mar 23 14:40:33.597 PDT
BGP router identifier 4.4.4.4, local AS number 3
BGP generic scan interval 60 secs
Non-stop routing is enabled
BGP table state: Active
Table ID: 0xe0000000 RD version: 66
BGP main routing table version 66
BGP NSR Initial initsync version 3 (Reached)
BGP NSR/ISSU Sync-Group versions 66/0
BGP scan interval 60 secs

Status codes: s suppressed, d damped, h history, * valid, > best
                i - internal, r RIB-failure, S stale, N Nexthop-discard
Origin codes: i - IGP, e - EGP, ? - incomplete
   Network        Next Hop           Metric LocPrf Weight Path
* 10.0.0.3/32     10.10.10.3          0      94      0 ?
* 10.0.0.5/32     10.11.11.5          0              0 5 ?
```

This example displays the large community attached to a network using the **show bgp ip-address/prefix-length** command.

```
RP/0/0/CPU0:R4# show bgp 10.3.3.3/32
Thu Mar 23 14:36:15.301 PDT
BGP routing table entry for 10.3.3.3/32
Versions:
  Process          bRIB/RIB  SendTblVer
  Speaker          42        42
Last Modified: Mar 22 20:04:46.000 for 18:31:30
Paths: (1 available, best #1)
  Advertised to peers (in unique update groups):
    10.11.11.5
  Path #1: Received by speaker 0
  Advertised to peers (in unique update groups):
    10.11.11.5
  Local
    10.10.10.3 from 10.10.10.3 (10.3.3.3)
      Origin incomplete, metric 0, localpref 94, valid, internal, best, group-best
      Received Path ID 0, Local Path ID 0, version 42
      Community: 258:259 260:261 262:263 264:265
      Large Community: 1:2:3 5:6:7 4123456789:4123456780:4123456788
```

Multiprotocol BGP

Multiprotocol BGP is an enhanced BGP that carries routing information for multiple network layer protocols and IP multicast routes. BGP carries two sets of routes, one set for unicast routing and one set for multicast

routing. The routes associated with multicast routing are used by the Protocol Independent Multicast (PIM) feature to build data distribution trees.

Multiprotocol BGP is useful when you want a link dedicated to multicast traffic, perhaps to limit which resources are used for which traffic. Multiprotocol BGP allows you to have a unicast routing topology different from a multicast routing topology providing more control over your network and resources.

In BGP, the only way to perform interdomain multicast routing was to use the BGP infrastructure that was in place for unicast routing. Perhaps you want all multicast traffic exchanged at one network access point (NAP). If those routers were not multicast capable, or there were differing policies for which you wanted multicast traffic to flow, multicast routing could not be supported without multiprotocol BGP.



Note It is possible to configure BGP peers that exchange both unicast and multicast network layer reachability information (NLRI), but you cannot connect multiprotocol BGP clouds with a BGP cloud. That is, you cannot redistribute multiprotocol BGP routes into BGP.

[Noncongruent Unicast and Multicast Routes](#) illustrates simple unicast and multicast topologies that are incongruent, and therefore are not possible without multiprotocol BGP.

Autonomous systems 100, 200, and 300 are each connected to two NAPs that are FDDI rings. One is used for unicast peering (and therefore the exchange of unicast traffic). The Multicast Friendly Interconnect (MFI) ring is used for multicast peering (and therefore the exchange of multicast traffic). Each router is unicast and multicast capable.

Figure 4: Noncongruent Unicast and Multicast Routes

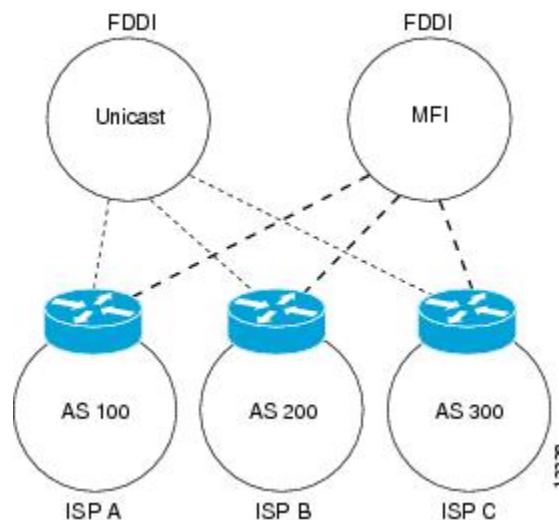

[Multicast BGP Environment](#) is a topology of unicast-only routers and multicast-only routers. The two routers on the left are unicast-only routers (that is, they do not support or are not configured to perform multicast routing). The two routers on the right are multicast-only routers. Routers A and B support both unicast and multicast routing. The unicast-only and multicast-only routers are connected to a single NAP.

In [Multicast BGP Environment](#), only unicast traffic can travel from Router A to the unicast routers to Router B and back. Multicast traffic could not flow on that path, so another routing table is required. Multicast traffic uses the path from Router A to the multicast routers to Router B and back.

Multicast BGP Environment illustrates a multiprotocol BGP environment with a separate unicast route and multicast route from Router A to Router B. Multiprotocol BGP allows these routes to be incongruent. Both of the autonomous systems must be configured for internal multiprotocol BGP (IMBGP) in the figure.

A multicast routing protocol, such as PIM, uses the multicast BGP database to perform Reverse Path Forwarding (RPF) lookups for multicast-capable sources. Thus, packets can be sent and accepted on the multicast topology but not on the unicast topology.

Figure 5: Multicast BGP Environment

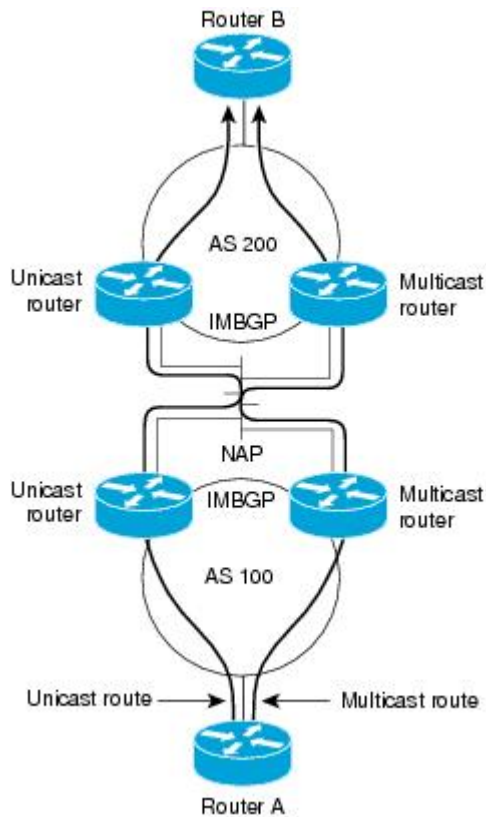

Redistributing Prefixes into Multiprotocol BGP

Perform this task to redistribute prefixes from another protocol into multiprotocol BGP.

Redistribution is the process of injecting prefixes from one routing protocol into another routing protocol. This task shows how to inject prefixes from another routing protocol into multiprotocol BGP. Specifically, prefixes that are redistributed into multiprotocol BGP using the **redistribute** command are injected into the unicast database.



Note BGP doesn't support redistribution of ISIS routes in VRF.

SUMMARY STEPS

1. configure

2. **router bgp** *as-number*
3. **address-family** { **ipv4** | **ipv6** } **unicast**
4. Do one of the following:
 - **redistribute connected** [**metric** *metric-value*] [**route-policy** *route-policy-name*]
 - **redistribute eigrp** *process-id* [**match** { **external** | **internal** }] [**metric** *metric-value*] [**route-policy** *route-policy-name*]
 - **redistribute ospf** *process-id* [**match** { **external** [**1** | **2**] | **internal** | **nssa-external** [**1** | **2**] }] [**metric** *metric-value*] [**route-policy** *route-policy-name*]
 - **redistribute ospfv3** *process-id* [**match** { **external** [**1** | **2**] | **internal** | **nssa-external** [**1** | **2**] }] [**metric** *metric-value*] [**route-policy** *route-policy-name*]
 - **redistribute rip** [**metric** *metric-value*] [**route-policy** *route-policy-name*]
 - **redistribute static** [**metric** *metric-value*] [**route-policy** *route-policy-name*]
5. Use the **commit** or **end** command.

DETAILED STEPS

	Command or Action	Purpose
Step 1	configure Example: RP/0/RP0/CPU0:router# configure	Enters global configuration mode.
Step 2	router bgp <i>as-number</i> Example: RP/0/RP0/CPU0:router(config)# router bgp 120	Specifies the autonomous system number and enters the BGP configuration mode, allowing you to configure the BGP routing process.
Step 3	address-family { ipv4 ipv6 } unicast Example: RP/0/RP0/CPU0:router(config-bgp)# address-family ipv4 unicast	Specifies either the IPv4 or IPv6 address family and enters address family configuration submenu. To see a list of all the possible keywords and arguments for this command, use the CLI help (?).
Step 4	Do one of the following: <ul style="list-style-type: none"> • redistribute connected [metric <i>metric-value</i>] [route-policy <i>route-policy-name</i>] • redistribute eigrp <i>process-id</i> [match { external internal }] [metric <i>metric-value</i>] [route-policy <i>route-policy-name</i>] • redistribute ospf <i>process-id</i> [match { external [1 2] internal nssa-external [1 2] }] [metric <i>metric-value</i>] [route-policy <i>route-policy-name</i>] • redistribute ospfv3 <i>process-id</i> [match { external [1 2] internal nssa-external [1 2] }] [metric <i>metric-value</i>] [route-policy <i>route-policy-name</i>] 	Causes routes from the specified instance to be redistributed into BGP.

	Command or Action	Purpose
	<ul style="list-style-type: none"> • redistribute rip [metric <i>metric-value</i>] [route-policy <i>route-policy-name</i>] • redistribute static [metric <i>metric-value</i>] [route-policy <i>route-policy-name</i>] <p>Example:</p> <pre>RP/0/RP0/CPU0:router(config-bgp-af)# redistribute ospf 110</pre>	
Step 5	Use the commit or end command.	<p>commit —Saves the configuration changes and remains within the configuration session.</p> <p>end —Prompts user to take one of these actions:</p> <ul style="list-style-type: none"> • Yes — Saves configuration changes and exits the configuration session. • No —Exits the configuration session without committing the configuration changes. • Cancel —Remains in the configuration session, without committing the configuration changes.

BGP Monitoring Protocol

The BGP Monitoring Protocol (BMP) feature enables monitoring of BGP speakers (called BMP clients). You can configure a device to function as a BMP server, which monitors either one or several BMP clients, which in turn, has several active peer sessions configured. You can also configure a BMP client to connect to one or more BMP servers. The BMP feature enables configuration of multiple BMP servers (configured as primary servers) to function actively and independent of each other, simultaneously to monitor BMP clients.

The BMP Protocol provides access to the Adjacent Routing Information Base, Incoming (Adj-RIB-In) table of a peer on an ongoing basis and a periodic dump of certain statistics that the monitoring station can use for further analysis. The BMP provides pre-policy view of the Adj-RIB-In table of a peer.

There can be several BMP servers configured globally across all the BGP instances. The BMP servers configured are common across multiple speaker instances and each BGP peer in an instance can be configured for monitoring by all or a subset of the BMP servers, giving a 'any-to-any' map between BGP peers and BMP servers from the point of view of a BGP speaker. If a BMP server is configured before any of the BGP peers come up, then the monitoring will start as soon as the BGP peers come up. A BMP server configuration can be removed only when there are no BGP peers configured to be monitored by that particular BMP server.

Sessions between BMP clients and BMP servers operate over plain TCP (no encryption/encapsulation). If a TCP session with the BMP server is not established, the client retries to connect every 7 seconds.

The BMP server does not send any messages to its clients (BGP speakers). The message flow is in one direction only—from BGP speakers to the BMP servers

A maximum of eight BMP servers can be configured on the Cisco NCS 5500 Series Routers. Each BMP server is specified by a server ID and certain parameters such as IP address, port number, etc are configurable.

Upon successful configuration of a BMP server with host and port details, the BGP speaker attempts to connect to BMP Server. Once the TCP connection is setup, an Initiation message is sent as first message.

The **bmp server** command enables the user to configure multiple—independent and asynchronous—BMP server connections.

All neighbors for a BGP speaker need not necessarily be BMP clients. BMP clients are the ones that have direct TCP connection with a BMP server. Each of these BGP speakers can have many BGP neighbors or peers. Under a BGP speaker, if any of its neighbors are configured for BMP monitoring, only that particular peer router's messages are sent to BMP servers.

The session connection to BMP server is attempted after an initial-delay at the BMP client. This initial-delay can be configured. If the initial-delay is not configured, then the default connection delay of 7 seconds is used. Configuring the initial delay becomes significant under certain circumstances where, if multiple BMP servers' states toggle closely and refresh delay is so small, then this might result in redundant route-refreshes being generated. This causes considerable network traffic and load on the device. Having different initial delays can reduce the load spike on the network and router.

After the initial delay, TCP connection to BMP servers are attempted. Once the server connections are up, it is checked if there are any peers enabled for monitoring. Once a BGP peer that is already being monitored is in the “ESTAB” state, speaker sends a “peer-up” message for that peer to the BMP server. After the BGP peer receives a route-refresh request, neighbor sends the updates. This route refresh is initiated based on a delay configured for each BMP server. This is called route refresh delay. When there are multiple neighbors to be monitored, each neighbor is set a refresh delay based upon the BMP server they are enabled for. Once all the BGP neighbors have sent the updates in response to the refresh requests, the tables will be up to date in the BMP Server. If a neighbor establishes connection after BMP monitoring has begun, it does not require a route-refresh request. All received routes from that neighbor is sent to BMP servers.



Note In the case of BMP Pre Inbound Policy Route monitoring, when a new BMP server comes up, route refresh requests are sent to the peer router by the BGP speaker. However, in the case of BMP Post Inbound Policy Route Monitoring route refresh request are not sent to the peer routers when the new BMP server comes up because the BMP table is used for update generation.

It is advantageous to batch up refresh requests to BGP peers, if several BMP servers are activated in quick succession. Use the **bmp server initial-refresh-delay** command to configure a delay in triggering the refresh mechanism when the first BMP server comes up. If other BMP servers come online within this time-frame, only one set of refresh requests is sent to the BGP peers. You can also configure the **bmp server initial-refresh-delay skip** command to skip all refresh requests from BGP speakers and just monitor all incoming messages from the peers.

In a client-server configuration, it is recommended that the resource load of the devices be kept minimal and adding excessive network traffic must be avoided. In the BMP configuration, you can configure various delay timers on the BMP server to avoid flapping during connection between the server and client.

BGP Flowspec Overview

The BGP flow specification (flowspec) feature allows you to rapidly deploy and propagate filtering and policing functionality among many BGP peer routers to mitigate the effects of a distributed denial-of-service (DDoS) attack over your network.

BGP Flowspec feature allows you to construct instructions to match a particular flow with IPv4 and IPv6 source, IPv4 and IPv6 destination, L4 parameters and packet specifics such as length, fragment, destination port and source port, actions that must be taken, such as dropping the traffic, or policing it at a definite rate, or redirect the traffic, through a BGP update. In the BGP update, the flowspec matching criteria is represented by Network Layer Reachability Information (BGP NLRI) and the actions are represented by BGP extended communities.

You can use the BGP Flowspec feature for mitigation of DDoS attack. When a DDoS attack occurs on a particular host inside a network, you can send a flowspec update to the border routers so that the attack traffic can be policed or dropped, or even redirected elsewhere. For example, to an appliance that cleans the traffic by filtering out the bad traffic and forward only the good traffic toward the affected host.

Once flowspecs have been received by a router and programmed in applicable line cards, any active L3 ports on those line cards start processing ingress traffic according to flowspec rules.



Note When you enable the `hw-module profile flowspec v6-enable` command, the packets per second (PPS) rate reduces. This reduction in PPS causes both IPv6 and IPv4 line rate degradation from 835Mpps to ~700Mpps.

The BGP Flowspec feature cannot coexist with MAP-E and PBR on a given interface. If you configure BGP Flowspec with PBR, the router does not display any error or system message. The router ignores the BGP Flowspec configuration and the feature will not function.



Note The list of BGP address families interacts with SRv6. There are some supported and unsupported BGP address families for the interaction with SRv6.

Supported address family:

- address-families ipv6.

Unsupported address families:

- address-families ipv4
 - vpv4
 - vpv6
-

Flow Specifications

A flow specification is an n-tuple consisting of several matching criteria that can be applied to IP traffic. A given IP packet matches the defined flow if it matches all the specified criteria.

Every flow-spec route is effectively a rule, consisting of a matching part (encoded in the NLRI field) and an action part (encoded as a BGP extended community). The BGP flowspec rules are converted internally to equivalent C3PL policy representing match and action parameters. The match and action support can vary based on underlying platform hardware capabilities. Sections *Supported Matching Criteria and Actions* and *Traffic Filtering Actions* provide information on the supported match (tuple definitions) and action parameters.



Note Up to 3,000 flowspec rules are supported in NCS 5500.

Supported Hardware

When you configure the router as a server, packet processing is not required. The router is not in the attack path, hence you can use any Cisco NCS 5500 Series router.

When you configure the router as a client, packets processing is required. You can choose one of the following:

- Cisco NCS 5500 series router modular platform: The line card that receives traffic must be of scale-enhanced type and must be equipped with the latest ASIC. In Release 6.5.1, only NC55-36X100G-A-SE line card can be used. The line card that transmits traffic can be of any flavor.
- Cisco NCS 5500 series router non-modular platform: In Release 6.5.1, only NCS-55A1-36H-SE-S chassis can be used.

When you configure the router as a client, it does not matter on which line card the BGP updates are received. The line card that receives the BGP update from BGP peer can be of any flavor.

Supported Matching Criteria and Actions

A flow specification NLRI type may include several components such as destination prefix, source prefix, protocol, ports, and so on. This NLRI is treated as an opaque bit string prefix by BGP. Each bit string identifies a key to a database entry with which a set of attributes can be associated. This NLRI information is encoded using MP_REACH_NLRI and MP_UNREACH_NLRI attributes. Whenever the corresponding application does not require Next-Hop information, this is encoded as a 0-octet length Next Hop in the MP_REACH_NLRI attribute, and ignored. The NLRI field of the MP_REACH_NLRI and MP_UNREACH_NLRI is encoded as a 1- or 2-octet NLRI length field followed by a variable-length NLRI value. The NLRI length is expressed in octets.

The flow specification NLRI type consists of several optional sub-components. A specific packet is considered to match the flow specification when it matches the intersection and of all the components present in the specification. The following are the supported component types or tuples that you can define:

BGP Flowspec NLRI type	QoS Match Fields	Description and Syntax Construction	Value Input Method
Type 1	IPv4 or IPv6 destination address	<p>Defines the destination prefix to match. Prefixes are encoded in the BGP UPDATE messages as a length in bits followed by enough octets to contain the prefix information.</p> <p>Encoding: <type (1 octet), prefix length (1 octet), prefix></p> <p>Syntax:</p> <p>match destination-address {ipv4 ipv6} address/mask length</p>	Prefix length

Type 2	IPv4 or IPv6 source address	<p>Defines the source prefix to match.</p> <p>Encoding: <type (1 octet), prefix-length (1 octet), prefix></p> <p>Syntax:</p> <p>match source-address {ipv4 ipv6} <i>address/mask length</i></p>	Prefix length
Type 3	IPv4 last next header or IPv6 protocol	<p>Contains a set of {operator, value} pairs that are used to match the IP protocol value byte in IP packets.</p> <p>Encoding: <type (1 octet), [op, value]+></p> <p>Syntax:</p> <p>Type 3: match protocol {<i>protocol-value</i> <i>min-value</i> -<i>max-value</i>}</p>	Multi value range
Type 4	IPv4 or IPv6 source or destination port	<p>Defines a list of {operation, value} pairs that matches source or destination TCP or UDP ports. Values are encoded as 1- or 2-byte quantities. Port, source port, and destination port components evaluate to FALSE if the IP protocol field of the packet has a value other than TCP or UDP. If the packet is fragmented and this is not the first fragment, or if the system is unable to locate the transport header.</p> <p>Encoding: <type (1 octet), [op, value]+></p> <p>Syntax:</p> <p>match source-port {<i>source-port-value</i> <i>min-value</i> -<i>max-value</i>}</p> <p>match destination-port {<i>destination-port-value</i> <i>min-value</i> -<i>max-value</i>}</p>	Multi value range
Type 5	IPv4 or IPv6 destination port	<p>Defines a list of {operation, value} pairs used to match the destination port of a TCP or UDP packet. Values are encoded as 1- or 2-byte quantities.</p> <p>Encoding: <type (1 octet), [op, value]+></p> <p>Syntax:</p> <p>match destination-port {<i>destination-port-value</i> [<i>min-value</i> - <i>max-value</i>]}</p>	Multi value range

Type 6	IPv4 or IPv6 Source port	<p>Defines a list of {operation, value} pairs used to match the source port of a TCP or UDP packet. Values are encoded as 1- or 2-byte quantities.</p> <p>Encoding: <type (1 octet), [op, value]+></p> <p>Syntax:</p> <p>match source-port {source-port-value [min-value - max-value]}</p>	Multi value range
Type 7	IPv4 or IPv6 ICMP type	<p>Defines a list of {operation, value} pairs used to match the type field of an Internet Control Message Packet (ICMP). Values are encoded using a single byte. The ICMP type and code specifiers evaluate to FALSE whenever the protocol value is not ICMP.</p> <p>Encoding: <type (1 octet), [op, value]+></p> <p>Syntax:</p> <p>match { ipv4 ipv6 } icmp-type value</p>	<p>Single value</p> <p>Note Multi value range is not supported.</p>
Type 8	IPv4 or IPv6 ICMP code	<p>Defines a list of {operation, value} pairs used to match the code field of an ICMP packet. Values are encoded using a single byte.</p> <p>Encoding: <type (1 octet), [op, value]+></p> <p>Syntax:</p> <p>match { ipv4 ipv6 } icmp-code value</p>	<p>Single value</p> <p>Note Multi value range is not supported.</p>
Type 9	<p>IPv4 or IPv6 TCP flags (2 bytes include reserved bits)</p> <p>Note Reserved and NS bit not supported</p>	<p>Bitmask values can be encoded as a 1- or 2-byte bitmask. When a single byte is specified, it matches byte 13 of the TCP header, which contains bits 8 through 15 of the 4th 32-bit word. When a 2-byte encoding is used, it matches bytes 12 and 13 of the TCP header with the data offset field having a "don't care" value. As with port specifier, this component evaluates to FALSE for packets that are not TCP packets. This type uses the bitmask operand format, which differs from the numeric operator format in the lower nibble.</p> <p>Encoding: <type (1 octet), [op, bitmask]+></p> <p>Syntax:</p> <p>match tcp-flag value bit-mask mask_value</p>	Bit mask

Type 10	IPv4 or IPv6 Packet length	Match on the total IP packet length (excluding Layer 2, but including IP header). Values are encoded using 1- or 2-byte quantities. Encoding: <type (1 octet), [op, value]+> Syntax: match packet length { <i>packet-length-value</i> <i>min-value</i> - <i>max-value</i> }	Multi value range
Type 11	IPv4 or IPv6 DSCP	Defines a list of {operation, value} pairs used to match the 6-bit DSCP field. Values are encoded using a single byte, where the two most significant bits are zero and the six least significant bits contain the DSCP value. Encoding: <type (1 octet), [op, value]+> Syntax: match dscp { <i>dscp-value</i> <i>min-value</i> - <i>max-value</i> }	Multi value range
Type 12	IPv4 Fragmentation bits Note IPv6 BGP flowspec does not support Type 12 NRLI.	Identifies a fragment-type as the match criterion for a class map. Encoding: <type (1 octet), [op, bitmask]+> Syntax: match fragment type [dont-fragment is-fragment last-fragment]	Bit mask

In a given flowspec rule, multiple action combinations can be specified without restrictions. However, mixing address family between matching criterion and actions are not allowed. For example, IPv4 matches cannot be combined with IPv6 actions and vice versa.



Note Redirect IP Nexthop is only supported in default VRF cases.

Traffic Filtering Actions

The default action for a traffic filtering flow specification is to accept IP traffic that matches that particular rule. The following extended community values can be used to specify particular actions:

Type	Extended Community	PBR Action	Description
------	--------------------	------------	-------------

0x8006	traffic-rate 0 traffic-rate <rate>	Drop Police	<p>The traffic-rate extended community is a non-transitive extended community across the autonomous-system boundary and uses following extended community encoding:</p> <p>The first two octets carry the 2-octet id, which can be assigned from a 2-byte AS number. When a 4-byte AS number is locally present, the 2 least significant bytes of such an AS number can be used. This value is informational. The remaining 4 octets carry the rate information in IEEE floating point [IEEE.754.1985] format, bytes per second. A traffic-rate of 0 should result on all traffic for the particular flow to be discarded.</p> <p>Command syntax</p> <pre>police rate <> drop</pre>
0x8008	redirect-vrf	Redirect VRF	<p>The redirect extended community allows the traffic to be redirected to a VRF routing instance that lists the specified route-target in its import policy. If several local instances match this criteria, the choice between them is decided locally (for example, the instance with the lowest Route Distinguisher value can be elected). This extended community uses the same encoding as the Route Target extended community [RFC4360].</p> <p>Command syntax based on route-target</p> <pre>redirect nexthop route-target route_target_string</pre>
0x8009	traffic-marking	Set DSCP	<p>The traffic marking extended community instructs a system to modify the differentiated service code point (DSCP) bits of a transiting IP packet to the corresponding value. This extended community is encoded as a sequence of 5 zero bytes followed by the DSCP value encoded in the 6 least significant bits of 6th byte.</p> <p>Command syntax</p> <pre>set dscp <6 bit value></pre>
0x0800	Redirect IP NH	Redirect IPv4 or IPv6 Nexthop	<p>Announces the reachability of one or more flowspec NLRI. When a BGP speaker receives an UPDATE message with the redirect-to- IP extended community it is expected to create a traffic filtering rule for every flow-spec NLRI in the message that has this path as its best path. The filter entry matches the IP packets described in the NLRI field and redirects them or copies them towards the IPv4 or IPv6 address specified in the Network Address of Next-Hop field of the associated MP_REACH_NLRI.</p> <p>Note The redirect-to-IP extended community is valid with any other set of flow-spec extended communities except if that set includes a redirect-to-VRF extended community (type 0x8008) and in that case the redirect-to-IP extended community should be ignored.</p> <p>Command syntax</p> <pre>redirect {ipv4 ipv6} next-hop {ipv4-address ipv6-address}</pre>

BGP Flowspec Client-Server ControllerModel and Configuration

The BGP Flowspec model comprises of a client and a server Controller. The Controller is responsible for sending or injecting the flowspec NRLI entry. The client (acting as a BGP speaker) receives that NRLI and programs the hardware forwarding to act on the instruction from the Controller. An illustration of this model is provided below.

BGP Flowspec Client

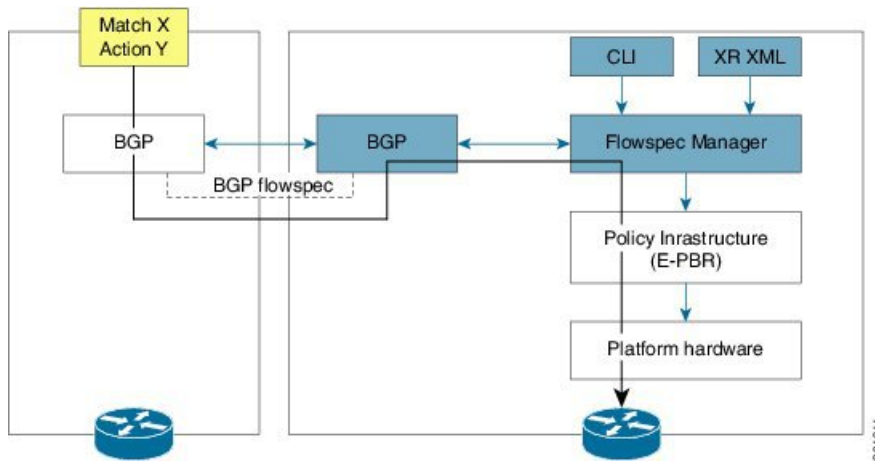

Here, the Controller on the left-hand side injects the flowspec NRLI, and the client on the right-hand side receives the information, sends it to the flowspec manager, configures the ePBR (Enhanced Policy-based Routing) infrastructure, which in turn programs the hardware from the underlying platform in use.

BGP Flowspec Controller

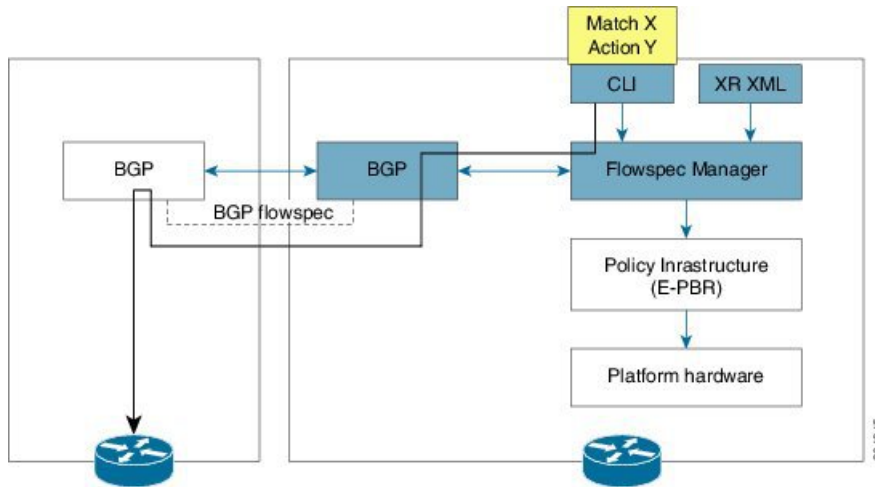

The Controller is configured using CLI to provide an entry for NRLI injection.

Configure BGP Flowspec

The following sections show how to configure BGP Flowspec feature.

Figure 6: BGP Flowspec

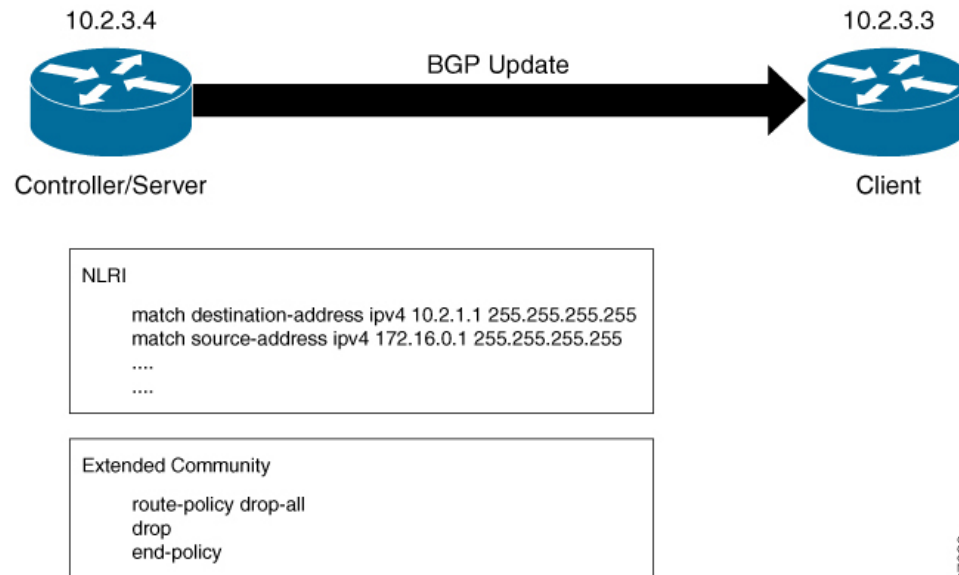

367630

The controller or the server with IP address 10.2.3.4 sends the Flowspec NLRI to the client with IP address 10.2.3.3. The NLRI consists of matching criteria, the client processes based on this criteria. Traffic is dropped or accepted based on the configured criteria.

The following section describes how you can configure BGP Flowspec on the client:

The following section describes how you can configure BGP Flowspec on the server:

```

/* Configure the policy to accept all presented routes without modifying the routes */
Router(config)# route-policy pass-all
Router(config)# pass
Router(config)# end-policy

/* Configure the policy to reject all presented routes without modifying the routes */
Router(config)# route-policy drop-all
Router(config)# drop
Router(config)# end-policy

/* Configure BGP towards flowspec client */
Router(config)# router bgp 1
Router(config-bgp)# nsr
Router(config-bgp)# bgp router-id 10.2.3.4
Router(config-bgp)# address-family ipv4 flowspec
Router(config-bgp-af)# exit
Router(config-bgp)# address-family ipv6 flowspec
Router(config-bgp-af)# exit
Router(config-bgp)# neighbor 10.2.3.3
Router(config-bgp-nbr)# remote-as 1
Router(config-bgp-nbr)# address-family ipv4 flowspec

Router(config-bgp-nbr-af)# route-policy pass-all in
Router(config-bgp-nbr-af)# route-policy pass-all out
Router(config-bgp-nbr-af)# exit
Router(config-bgp-nbr)# update-source Loopback0

/* Configure IPv4 flowspec to be advertised to client. Define traffic classes. */
Router(config)# class-map type traffic match-all ipv4_fragment
  
```

```

Router(config-cmap)# match destination-address ipv4 10.2.1.1 255.255.255.255
Router(config-cmap)# match source-address ipv4 172.16.0.1 255.255.255.255
Router(config-cmap)# match packet length 700
Router(config-cmap)# match dscp af21
Router(config-cmap)# match fragment-type is-fragment
Router(config-cmap)# end-class-map

Router(config)# class-map type traffic match-all ipv4_icmp
Router(config-cmap)# match destination-address ipv4 10.2.1.1 255.255.255.255
Router(config-cmap)# match source-address ipv4 172.16.0.1 255.255.255.255
Router(config-cmap)# match packet length 700
Router(config-cmap)# match dscp af21
Router(config-cmap)# match fragment-type is-fragment
Router(config-cmap)# match ipv4 icmp-type 3
Router(config-cmap)# match ipv4 icmp-code 2
Router(config-cmap)# end-class-map

/* Define a policy map and associate it with traffic classes.

Router(config)# policy-map type pbr scale_ipv4
Router(config-pmap)# class type traffic ipv4_fragment
Router(config-pmap-c)# drop
Router(config-pmap-c)# exit
Router(config-pmap)# class type traffic ipv4_icmp
Router(config-pmap-c)# police rate 1 mbps
Router(config-pmap-c)# set dscp cs2
Router(config-pmap-c)# redirect nexthop route-target 4787:13
Router(config-pmap-c)# exit
Router(config-pmap)# class type traffic class-default
Router(config-pmap-c)# end-policy-map

Router(config)# flowspec
Router(config)# address-family ipv4
Router(config-af)# service-policy type pbr scale_ipv4

/* Configure IPv6 flowspec to be advertised to client. Define traffic classes. */
Router(config)# class-map type traffic match-all ipv6_tcp
Router(config-cmap)# match destination-address ipv6 70:1:1::5a/128
Router(config-cmap)# match source-address ipv4 ipv6 80:1:1::5a/128
Router(config-cmap)# match protocol tcp
Router(config-cmap)# match destination-port 22
Router(config-cmap)# match source-port 4000
Router(config-cmap)# match tcp-flag 0x10
Router(config-cmap)# match packet length 300
Router(config-cmap)# match dscp af12
Router(config-cmap)# match fragment-type is-fragment
Router(config-cmap)# end-class-map

Router(config)# class-map type traffic match-all ipv6_icmp
Router(config-cmap)# match destination-address ipv6 70:2:1::1/128
Router(config-cmap)# match source-address ipv4 ipv6 80:2:1::1/128
Router(config-cmap)# match packet length 800
Router(config-cmap)# match dscp af22
Router(config-cmap)# match ipv6 icmp-type 4
Router(config-cmap)# match ipv6 icmp-code 1
Router(config-cmap)# end-class-map

/* Define a policy map and associate it with traffic classes.

Router(config)# policy-map type pbr scale_ipv6
Router(config-pmap)# class type traffic ipv6_tcp
Router(config-pmap-c)# police rate 1 mbps
Router(config-pmap-c)# set dscp cs1

```



```

Router(config-pmap-c)# redirect ipv6 nexthop 202:158:2::1
Router(config-pmap-c)# exit
Router(config-pmap)# class type traffic ipv6_icmp
Router(config-pmap-c)# police rate 1 mbps
Router(config-pmap-c)# set dscp cs3
Router(config-pmap-c)# redirect nexthop route-target 4787:13
Router(config-pmap-c)# exit
Router(config-pmap)# class type traffic class-default
Router(config-pmap-c)# end-policy-map

Router(config)# flowspec
Router(config)# address-family ipv6
Router(config-af)# service-policy type pbr scale_ipv6

```

Running Configuration

Verification

The following show output displays the status of the flowspec from the client side.

```

Router# show bgp ipv4 flowspec
GP router identifier 202.158.0.1, local AS number 4787
BGP generic scan interval 60 secs
Non-stop routing is enabled
BGP table state: Active
Table ID: 0x0 RD version: 7506
BGP main routing table version 7506
BGP NSR Initial initsync version 130 (Reached)
BGP NSR/ISSU Sync-Group versions 7506/0
BGP scan interval 60 secs

Status codes: s suppressed, d damped, h history, * valid, > best
               i - internal, r RIB-failure, S stale, N Nexthop-discard
Origin codes: i - IGP, e - EGP, ? - incomplete
   Network          Next Hop          Metric LocPrf Weight Path
*>iDest:10.1.1.1/32,Proto:=6,DPort:=80,SPort:=3000,Length:=200,DSCP:=10/176
                0.0.0.0                    10      0 ?
*>iDest:10.1.1.2/32,Proto:=6,DPort:=80,SPort:=3000,Length:=200,DSCP:=10/176
                0.0.0.0                    10      0 ?
*>iDest:10.1.1.3/32,Proto:=6,DPort:=80,SPort:=3000,Length:=200,DSCP:=10/176
                0.0.0.0                    10      0 ?
*>iDest:10.1.1.4/32,Proto:=6,DPort:=80,SPort:=3000,Length:=200,DSCP:=10/176
                0.0.0.0                    10      0 ?
*>iDest:10.1.1.5/32,Proto:=6,DPort:=80,SPort:=3000,Length:=200,DSCP:=10/176
                0.0.0.0                    10      0 ?

Router# show bgp ipv6 flowspec
BGP router identifier 202.158.0.1, local AS number 4787
BGP generic scan interval 60 secs
Non-stop routing is enabled
BGP table state: Active
Table ID: 0x0 RD version: 1503
BGP main routing table version 1504
BGP NSR Initial initsync version 2 (Reached)
BGP NSR/ISSU Sync-Group versions 1504/0
BGP scan interval 60 secs

Status codes: s suppressed, d damped, h history, * valid, > best
               i - internal, r RIB-failure, S stale, N Nexthop-discard
Origin codes: i - IGP, e - EGP, ? - incomplete
   Network          Next Hop          Metric LocPrf Weight Path
*>iDest:70:1:1::1/0-128,Source:80:1:1::1/0-128,NH:=6,DPort:=22,SPort:=4000,TCFFlags:=0x10,Length:=300,DSCP:=12/464
                202:158:2::1                100      0 i

```

```
*>iDest:70:1:1::2/0-128,Source:80:1:1::2/0-128,NH:=6,DPort:=22,SPort:=4000,TCPFlags:=0x10,Length:=300,DSCP:=12/464
                202:158:2::1                100      0 i
*>iDest:70:1:1::3/0-128,Source:80:1:1::3/0-128,NH:=6,DPort:=22,SPort:=4000,TCPFlags:=0x10,Length:=300,DSCP:=12/464
                202:158:2::1                100      0 i
*>iDest:70:1:1::4/0-128,Source:80:1:1::4/0-128,NH:=6,DPort:=22,SPort:=4000,TCPFlags:=0x10,Length:=300,DSCP:=12/464
                202:158:2::1                100      0 i
*>iDest:70:1:1::5/0-128,Source:80:1:1::5/0-128,NH:=6,DPort:=22,SPort:=4000,TCPFlags:=0x10,Length:=300,DSCP:=12/464
                202:158:2::1                100      0 i
```

Router# **show bgp vpnv4 flowspec**

```
BGP router identifier 202.158.0.1, local AS number 4787
BGP generic scan interval 60 secs
Non-stop routing is enabled
BGP table state: Active
Table ID: 0x0  RD version: 0
BGP main routing table version 5
BGP NSR Initial initsync version 3 (Reached)
BGP NSR/ISSU Sync-Group versions 5/0
BGP scan interval 60 secs
```

```
Status codes: s suppressed, d damped, h history, * valid, > best
                i - internal, r RIB-failure, S stale, N Nexthop-discard
Origin codes: i - IGP, e - EGP, ? - incomplete
```

```
Network          Next Hop          Metric LocPrf Weight Path
Route Distinguisher: 202.158.0.1:0 (default for vrf customer_1)
*>iDest:202.158.3.2/32,Source:202.158.1.2/32/96
                0.0.0.0                100      0 i
Route Distinguisher: 202.158.0.2:1
*>iDest:202.158.3.2/32,Source:202.158.1.2/32/96
                0.0.0.0                100      0 i
```

Processed 2 prefixes, 2 paths

Router# **show bgp vpnv6 flowspec**

```
BGP router identifier 202.158.0.1, local AS number 4787
BGP generic scan interval 60 secs
Non-stop routing is enabled
BGP table state: Active
Table ID: 0x0  RD version: 0
BGP main routing table version 5
BGP NSR Initial initsync version 4 (Reached)
BGP NSR/ISSU Sync-Group versions 5/0
BGP scan interval 60 secs
```

```
Status codes: s suppressed, d damped, h history, * valid, > best
                i - internal, r RIB-failure, S stale, N Nexthop-discard
Origin codes: i - IGP, e - EGP, ? - incomplete
```

```
Network          Next Hop          Metric LocPrf Weight Path
Route Distinguisher: 202.158.0.1:0 (default for vrf customer_1)
*>iDest:200:158:3::2/0-128,Source:200:158:1::2/0-128,NH:=6,DPort:=22,SPort:=4000,Length:=300,DSCP:=12/440
                0.0.0.0                100      0 i
Route Distinguisher: 202.158.0.2:1
*>iDest:200:158:3::2/0-128,Source:200:158:1::2/0-128,NH:=6,DPort:=22,SPort:=4000,Length:=300,DSCP:=12/440
                0.0.0.0                100      0 i
```

Processed 2 prefixes, 2 paths

```
Router# show bgp ipv6 flowspec summary
BGP router identifier 202.158.0.1, local AS number 4787
BGP generic scan interval 60 secs
Non-stop routing is enabled
BGP table state: Active
Table ID: 0x0 RD version: 1503
BGP main routing table version 1504
BGP NSR Initial initsync version 2 (Reached)
BGP NSR/ISSU Sync-Group versions 1504/0
BGP scan interval 60 secs
```

BGP is operating in STANDALONE mode.

Process	RcvTblVer	bRIB/RIB	LabelVer	ImportVer	SendTblVer	StandbyVer
Speaker	1504	1504	1504	1504	1504	1504

Neighbor	Spk	AS	MsgRcvd	MsgSent	TblVer	InQ	OutQ	Up/Down	St/PfxRcd
200.255.1.5	0	4787	6957	2957	1504	0	0	04:48:02	0
200.255.1.6	0	50011	3015	3010	0	0	0	05:27:50	(NoNeg)
202.158.2.1	0	4787	1548	1648	1504	0	0	1d01h	750 <-- this
many flowspecs were received from server									
202.158.3.1	0	4787	1683	1644	1504	0	0	1d01h	751
202.158.4.1	0	4787	1543	1649	1504	0	0	1d01h	0

```
sh bgp vpv4 flowspec summary
BGP router identifier 202.158.0.1, local AS number 4787
BGP generic scan interval 60 secs
Non-stop routing is enabled
BGP table state: Active
Table ID: 0x0 RD version: 0
BGP main routing table version 5
BGP NSR Initial initsync version 3 (Reached)
BGP NSR/ISSU Sync-Group versions 5/0
BGP scan interval 60 secs
```

BGP is operating in STANDALONE mode.

Process	RcvTblVer	bRIB/RIB	LabelVer	ImportVer	SendTblVer	StandbyVer
Speaker	5	5	5	5	5	5

Neighbor	Spk	AS	MsgRcvd	MsgSent	TblVer	InQ	OutQ	Up/Down	St/PfxRcd
202.158.2.1	0	4787	1549	1648	5	0	0	1d01h	1 <-- this
many flowspecs were received from server									
202.158.3.1	0	4787	1684	1644	5	0	0	1d01h	0
202.158.4.1	0	4787	1543	1649	5	0	0	1d01h	0

```
Router# show bgp vpv6 flowspec summary
BGP router identifier 202.158.0.1, local AS number 4787
BGP generic scan interval 60 secs
Non-stop routing is enabled
BGP table state: Active
Table ID: 0x0 RD version: 0
BGP main routing table version 5
BGP NSR Initial initsync version 4 (Reached)
BGP NSR/ISSU Sync-Group versions 5/0
BGP scan interval 60 secs
```

BGP is operating in STANDALONE mode.

Process	RcvTblVer	bRIB/RIB	LabelVer	ImportVer	SendTblVer	StandbyVer
---------	-----------	----------	----------	-----------	------------	------------

```

Speaker                5          5          5          5          5          5
Neighbor              Spk    AS MsgRcvd MsgSent  TblVer  InQ  OutQ  Up/Down  St/PfxRcd
202.158.2.1           0  4787   1549   1649      5    0    0    1d01h    1 <-- this
many flowspecs were received from server
202.158.3.1           0  4787   1684   1645      5    0    0    1d01h     0
202.158.4.1           0  4787   1543   1650      5    0    0    1d01h     0

```

Router# **show flowspec ipv4 detail**

```

AFI: IPv4
Flow                :Dest:10.1.1.1/32,Proto:=6,DPort:=80,SPort:=3000,Length:=200,DSCP:=10
Actions             :Traffic-rate: 0 bps (bgp.1)
Statistics          (packets/bytes)
  Matched           :                18174999/3707699796
  Transmitted       :                0/0
  Dropped           :                18174999/3707699796

```

Router# **show flowspec ipv6 detail**

```

AFI: IPv6
Flow
:Dest:70:1:1::1/0-128,Source:80:1:1::1/0-128,NH:=6,DPort:=22,SPort:=4000,TCPFflags:=0x10,Length:=300,DSCP:=12

Actions             :Traffic-rate: 1000000 bps DSCP: cs1 Nexthop: 202:158:2::1 (bgp.1)
Statistics          (packets/bytes)
  Matched           :                64091597/19483845488
  Transmitted       :                33973978/10328089312
  Dropped           :                30117619/9155756176

```

Router# **show flowspec vrf customer_1 ipv4 detail**

```

VRF: customer_1    AFI: IPv4
Flow                :Dest:202.158.3.2/32,Source:202.158.1.2/32
Actions             :Traffic-rate: 250000000 bps DSCP: cs6 Redirect: VRF dirty_dancing
Route-target: ASN2-4787:666 (bgp.1)
Statistics          (packets/bytes)
  Matched           :                37260786850/4098686553500
  Transmitted       :                21304093027/2343450232970
  Dropped           :                15956693823/1755236320530

```

Router# **show flowspec vrf customer_1 ipv6 detail**

```

VRF: customer_1    AFI: IPv6
Flow
:Dest:200:158:3::2/0-128,Source:200:158:1::2/0-128,NH:=6,DPort:=22,SPort:=4000,Length:=300,DSCP:=12

Actions             :Traffic-rate: 250000000 bps DSCP: cs6 Redirect: VRF dirty_dancing
Route-target: ASN2-4787:666 (bgp.1)
Statistics          (packets/bytes)
  Matched           :                16130480136/4903665961344
  Transmitted       :                8490755776/2581189755904
  Dropped           :                7639724360/2322476205440

```

Router# **show flowspec ipv4 nlri**

```

AFI: IPv4
NLRI (hex)         :0x01204601010103810605815006910bb80a81c80b810a
Actions            :Traffic-rate: 0 bps (bgp.1)

```

Router# **show flowspec ipv6 nlri**

```

AFI: IPv6

```

```

NLRI (hex)
:0x0180000070000100010000000000000000010280000800001000100000000000000000103810605811606910fa00981100a91012c0b810c

Actions      :Traffic-rate: 1000000 bps DSCP: cs1 Nexthop: 202:158:2::1 (bgp.1)

Router# show flowspec vrf customer_1 ipv4 nlri
VRF: customer_1      AFI: IPv4
NLRI (hex)          :0x0120ca9e03020220ca9e0102
Actions             :Traffic-rate: 250000000 bps DSCP: cs6 Redirect: VRF dirty_dancing
Route-target: ASN2-4787:666 (bgp.1)

Router# show flowspec vrf customer_1 ipv6 nlri

VRF: customer_1      AFI: IPv6
NLRI (hex)          :0x01800002000158000300000000000000000000002028000020001580001000000000000000000000203810605811606910fa00a91012c0b810c

Actions             :Traffic-rate: 250000000 bps DSCP: cs6 Redirect: VRF dirty_dancing
Route-target: ASN2-4787:666 (bgp.1)

Router# show policy-map transient type pbr
policy-map type pbr __bgpfs_default_IPv4
handle:0x36000004
table description: L3 IPv4 and IPv6
class handle:0x760013eb sequence 1024
 match destination-address ipv4 10.1.1.1 255.255.255.255
 match protocol tcp
 match destination-port 80
 match source-port 3000
 match packet length 200
 match dscp 10
 drop
!
```

Flow Specifications

A flow specification is an n-tuple consisting of several matching criteria that can be applied to IP traffic. A given IP packet matches the defined flow if it matches all the specified criteria.

Every flow-spec route is effectively a rule, consisting of a matching part (encoded in the NLRI field) and an action part (encoded as a BGP extended community). The BGP flowspec rules are converted internally to equivalent C3PL policy representing match and action parameters. The match and action support can vary based on underlying platform hardware capabilities. Sections *Supported Matching Criteria and Actions* and *Traffic Filtering Actions* provide information on the supported match (tuple definitions) and action parameters.



Note Up to 3,000 flowspec rules are supported in NCS 5500.

BGP Policy Accounting

Border Gateway Protocol (BGP) policy accounting measures and classifies IP traffic that is received from, different peers. Policy accounting is enabled on an individual input interface basis, and counters based on parameters such as community list, autonomous system number, or autonomous system path are assigned to identify the IP traffic.



Note There are two types of route policies. The first type (regular BGP route policies) is used to filter the BGP routes advertised into or out from the BGP links. This type of route policy is applied to the specific BGP neighbor. The second type (specific route policy) is used to set up a traffic index for the BGP prefixes. This route policy is applied to the global BGP IPv4 or IPv6 address family to set up the traffic index when the BGP routes are inserted into the RIB table. BGP policy accounting uses the second type of route policy.

Using BGP policy accounting, you can account for traffic according to the route it traverses. Service providers can identify and account for all traffic by customer and bill accordingly. In the [Figure 7: Sample Topology for BGP Policy Accounting](#), BGP policy accounting can be implemented in Router A to measure packet and byte volumes in autonomous system buckets. Customers are billed appropriately for traffic that is routed from a domestic, international, or satellite source.



Note BGP policy accounting measures and classifies IP traffic for BGP prefixes only.

Figure 7: Sample Topology for BGP Policy Accounting

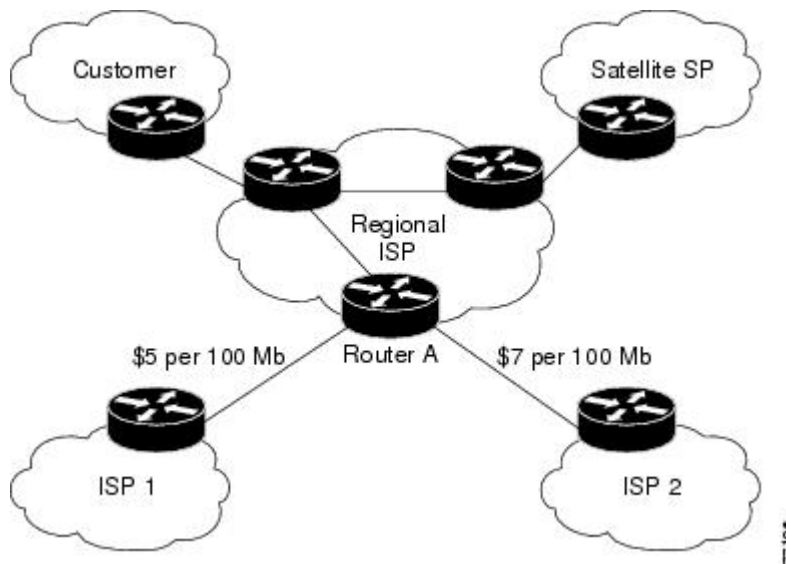

Based on the specified routing policy, BGP policy accounting assigns each prefix a traffic index (bucket) associated with an interface. BGP prefixes are downloaded from the RIB to the FIB along with the traffic index.

There are a total of 15 (1 to 15) traffic indexes (bucket numbers) that can be assigned for BGP prefixes. Internally, there is an accounting table associated with the traffic indexes to be created for each input (ingress). The traffic indexes allow you to account for the IP traffic, where the destination IP address is BGP prefixes.



Note

- The default traffic index for BGP route is 0.
- The traffic index 0 is accounted into the *default* bucket.

BGP Flowspec Overview

The BGP flow specification (flowspec) feature allows you to rapidly deploy and propagate filtering and policing functionality among many BGP peer routers to mitigate the effects of a distributed denial-of-service (DDoS) attack over your network.

BGP Flowspec feature allows you to construct instructions to match a particular flow with IPv4 and IPv6 source, IPv4 and IPv6 destination, L4 parameters and packet specifics such as length, fragment, destination port and source port, actions that must be taken, such as dropping the traffic, or policing it at a definite rate, or redirect the traffic, through a BGP update. In the BGP update, the flowspec matching criteria is represented by Network Layer Reachability Information (BGP NLRI) and the actions are represented by BGP extended communities.

You can use the BGP Flowspec feature for mitigation of DDoS attack. When a DDoS attack occurs on a particular host inside a network, you can send a flowspec update to the border routers so that the attack traffic can be policed or dropped, or even redirected elsewhere. For example, to an appliance that cleans the traffic by filtering out the bad traffic and forward only the good traffic toward the affected host.

Once flowspecs have been received by a router and programmed in applicable line cards, any active L3 ports on those line cards start processing ingress traffic according to flowspec rules.



Note When you enable the hw-module profile flowspec v6-enable command, the packets per second (PPS) rate reduces. This reduction in PPS causes both IPv6 and IPv4 line rate degradation from 835Mpps to ~700Mpps.

The BGP Flowspec feature cannot coexist with MAP-E and PBR on a given interface. If you configure BGP Flowspec with PBR, the router does not display any error or system message. The router ignores the BGP Flowspec configuration and the feature will not function.



Note The list of BGP address families interacts with SRv6. There are some supported and unsupported BGP address families for the interaction with SRv6.

Supported address family:

- address-families ipv6.

Unsupported address families:

- address-families ipv4
 - vpv4
 - vpv6
-

Flow Specifications

A flow specification is an n-tuple consisting of several matching criteria that can be applied to IP traffic. A given IP packet matches the defined flow if it matches all the specified criteria.

Every flow-spec route is effectively a rule, consisting of a matching part (encoded in the NLRI field) and an action part (encoded as a BGP extended community). The BGP flowspec rules are converted internally to equivalent C3PL policy representing match and action parameters. The match and action support can vary based on underlying platform hardware capabilities. Sections *Supported Matching Criteria and Actions* and *Traffic Filtering Actions* provide information on the supported match (tuple definitions) and action parameters.



Note Up to 3,000 flowspec rules are supported in NCS 5500.

Supported Hardware

When you configure the router as a server, packet processing is not required. The router is not in the attack path, hence you can use any Cisco NCS 5500 Series router.

When you configure the router as a client, packets processing is required. You can choose one of the following:

- Cisco NCS 5500 series router modular platform: The line card that receives traffic must be of scale-enhanced type and must be equipped with the latest ASIC. In Release 6.5.1, only NC55-36X100G-A-SE line card can be used. The line card that transmits traffic can be of any flavor.
- Cisco NCS 5500 series router non-modular platform: In Release 6.5.1, only NCS-55A1-36H-SE-S chassis can be used.

When you configure the router as a client, it does not matter on which line card the BGP updates are received. The line card that receives the BGP update from BGP peer can be of any flavor.

Supported Matching Criteria and Actions

A flow specification NLRI type may include several components such as destination prefix, source prefix, protocol, ports, and so on. This NLRI is treated as an opaque bit string prefix by BGP. Each bit string identifies a key to a database entry with which a set of attributes can be associated. This NLRI information is encoded using MP_REACH_NLRI and MP_UNREACH_NLRI attributes. Whenever the corresponding application does not require Next-Hop information, this is encoded as a 0-octet length Next Hop in the MP_REACH_NLRI attribute, and ignored. The NLRI field of the MP_REACH_NLRI and MP_UNREACH_NLRI is encoded as a 1- or 2-octet NLRI length field followed by a variable-length NLRI value. The NLRI length is expressed in octets.

The flow specification NLRI type consists of several optional sub-components. A specific packet is considered to match the flow specification when it matches the intersection and of all the components present in the specification. The following are the supported component types or tuples that you can define:

BGP Flowspec NLRI type	QoS Match Fields	Description and Syntax Construction	Value Input Method

Type 1	IPv4 or IPv6 destination address	<p>Defines the destination prefix to match. Prefixes are encoded in the BGP UPDATE messages as a length in bits followed by enough octets to contain the prefix information.</p> <p>Encoding: <type (1 octet), prefix length (1 octet), prefix></p> <p>Syntax:</p> <p>match destination-address {ipv4 ipv6} <i>address/mask length</i></p>	Prefix length
Type 2	IPv4 or IPv6 source address	<p>Defines the source prefix to match.</p> <p>Encoding: <type (1 octet), prefix-length (1 octet), prefix></p> <p>Syntax:</p> <p>match source-address {ipv4 ipv6} <i>address/mask length</i></p>	Prefix length
Type 3	IPv4 last next header or IPv6 protocol	<p>Contains a set of {operator, value} pairs that are used to match the IP protocol value byte in IP packets.</p> <p>Encoding: <type (1 octet), [op, value]+></p> <p>Syntax:</p> <p>Type 3: match protocol {<i>protocol-value</i> <i>min-value</i> -<i>max-value</i>}</p>	Multi value range
Type 4	IPv4 or IPv6 source or destination port	<p>Defines a list of {operation, value} pairs that matches source or destination TCP or UDP ports. Values are encoded as 1- or 2-byte quantities. Port, source port, and destination port components evaluate to FALSE if the IP protocol field of the packet has a value other than TCP or UDP. If the packet is fragmented and this is not the first fragment, or if the system is unable to locate the transport header.</p> <p>Encoding: <type (1 octet), [op, value]+></p> <p>Syntax:</p> <p>match source-port {<i>source-port-value</i> <i>min-value</i> -<i>max-value</i>}</p> <p>match destination-port {<i>destination-port-value</i> <i>min-value</i> -<i>max-value</i>}</p>	Multi value range

Type 5	IPv4 or IPv6 destination port	<p>Defines a list of {operation, value} pairs used to match the destination port of a TCP or UDP packet. Values are encoded as 1- or 2-byte quantities.</p> <p>Encoding: <type (1 octet), [op, value]+></p> <p>Syntax:</p> <p>match destination-port <i>{destination-port-value [min-value - max-value]}</i></p>	Multi value range
Type 6	IPv4 or IPv6 Source port	<p>Defines a list of {operation, value} pairs used to match the source port of a TCP or UDP packet. Values are encoded as 1- or 2-byte quantities.</p> <p>Encoding: <type (1 octet), [op, value]+></p> <p>Syntax:</p> <p>match source-port <i>{source-port-value [min-value - max-value]}</i></p>	Multi value range
Type 7	IPv4 or IPv6 ICMP type	<p>Defines a list of {operation, value} pairs used to match the type field of an Internet Control Message Packet (ICMP). Values are encoded using a single byte. The ICMP type and code specifiers evaluate to FALSE whenever the protocol value is not ICMP.</p> <p>Encoding: <type (1 octet), [op, value]+></p> <p>Syntax:</p> <p>match {ipv4 ipv6} icmp-type value</p>	<p>Single value</p> <p>Note Multi value range is not supported.</p>
Type 8	IPv4 or IPv6 ICMP code	<p>Defines a list of {operation, value} pairs used to match the code field of an ICMP packet. Values are encoded using a single byte.</p> <p>Encoding: <type (1 octet), [op, value]+></p> <p>Syntax:</p> <p>match {ipv4 ipv6} icmp-code value</p>	<p>Single value</p> <p>Note Multi value range is not supported.</p>

Type 9	<p>IPv4 or IPv6 TCP flags (2 bytes include reserved bits)</p> <p>Note Reserved and NS bit not supported</p>	<p>Bitmask values can be encoded as a 1- or 2-byte bitmask. When a single byte is specified, it matches byte 13 of the TCP header, which contains bits 8 through 15 of the 4th 32-bit word. When a 2-byte encoding is used, it matches bytes 12 and 13 of the TCP header with the data offset field having a "don't care" value. As with port specifier, this component evaluates to FALSE for packets that are not TCP packets. This type uses the bitmask operand format, which differs from the numeric operator format in the lower nibble.</p> <p>Encoding: <type (1 octet), [op, bitmask]+></p> <p>Syntax:</p> <p>match tcp-flag <i>value</i> bit-mask <i>mask_value</i></p>	Bit mask
Type 10	IPv4 or IPv6 Packet length	<p>Match on the total IP packet length (excluding Layer 2, but including IP header). Values are encoded using 1- or 2-byte quantities.</p> <p>Encoding: <type (1 octet), [op, value]+></p> <p>Syntax:</p> <p>match packet length {<i>packet-length-value</i> <i>min-value</i> - <i>max-value</i>}</p>	Multi value range
Type 11	IPv4 or IPv6 DSCP	<p>Defines a list of {operation, value} pairs used to match the 6-bit DSCP field. Values are encoded using a single byte, where the two most significant bits are zero and the six least significant bits contain the DSCP value.</p> <p>Encoding: <type (1 octet), [op, value]+></p> <p>Syntax:</p> <p>match dscp {<i>dscp-value</i> <i>min-value</i> - <i>max-value</i>}</p>	Multi value range
Type 12	<p>IPv4 Fragmentation bits</p> <p>Note IPv6 BGP flowspec does not support Type 12 NRLI.</p>	<p>Identifies a fragment-type as the match criterion for a class map.</p> <p>Encoding: <type (1 octet), [op, bitmask]+></p> <p>Syntax:</p> <p>match fragment type [dont-fragment is-fragment last-fragment]</p>	Bit mask

In a given flowspec rule, multiple action combinations can be specified without restrictions. However, mixing address family between matching criterion and actions are not allowed. For example, IPv4 matches cannot be combined with IPv6 actions and vice versa.



Note Redirect IP Nexthop is only supported in default VRF cases.

Traffic Filtering Actions

The default action for a traffic filtering flow specification is to accept IP traffic that matches that particular rule. The following extended community values can be used to specify particular actions:

Type	Extended Community	PBR Action	Description
0x8006	traffic-rate 0 traffic-rate <rate>	Drop Police	<p>The traffic-rate extended community is a non-transitive extended community across the autonomous-system boundary and uses following extended community encoding:</p> <p>The first two octets carry the 2-octet id, which can be assigned from a 2-byte AS number. When a 4-byte AS number is locally present, the 2 least significant bytes of such an AS number can be used. This value is informational. The remaining 4 octets carry the rate information in IEEE floating point [IEEE.754.1985] format, bytes per second. A traffic-rate of 0 should result on all traffic for the particular flow to be discarded.</p> <p>Command syntax police rate <> drop</p>
0x8008	redirect-vrf	Redirect VRF	<p>The redirect extended community allows the traffic to be redirected to a VRF routing instance that lists the specified route-target in its import policy. If several local instances match this criteria, the choice between them is decided locally (for example, the instance with the lowest Route Distinguisher value can be elected). This extended community uses the same encoding as the Route Target extended community [RFC4360].</p> <p>Command syntax based on route-target redirect nexthop route-target route_target_string</p>
0x8009	traffic-marking	Set DSCP	<p>The traffic marking extended community instructs a system to modify the differentiated service code point (DSCP) bits of a transiting IP packet to the corresponding value. This extended community is encoded as a sequence of 5 zero bytes followed by the DSCP value encoded in the 6 least significant bits of 6th byte.</p> <p>Command syntax set dscp <6 bit value></p>

0x0800	Redirect IP NH	Redirect IPv4 or IPv6 Nexthop	<p>Announces the reachability of one or more flowspec NLRI. When a BGP speaker receives an UPDATE message with the redirect-to- IP extended community it is expected to create a traffic filtering rule for every flow-spec NLRI in the message that has this path as its best path. The filter entry matches the IP packets described in the NLRI field and redirects them or copies them towards the IPv4 or IPv6 address specified in the Network Address of Next-Hop field of the associated MP_REACH_NLRI.</p> <p>Note The redirect-to-IP extended community is valid with any other set of flow-spec extended communities except if that set includes a redirect-to-VRF extended community (type 0x8008) and in that case the redirect-to-IP extended community should be ignored.</p> <p>Command syntax</p> <pre>redirect {ipv4 ipv6} next-hop {ipv4-address ipv6-address}</pre>
--------	----------------	-------------------------------	---

BGP Flowspec Client-Server ControllerModel and Configuration

The BGP Flowspec model comprises of a client and a server Controller. The Controller is responsible for sending or injecting the flowspec NRLI entry. The client (acting as a BGP speaker) receives that NRLI and programs the hardware forwarding to act on the instruction from the Controller. An illustration of this model is provided below.

BGP Flowspec Client

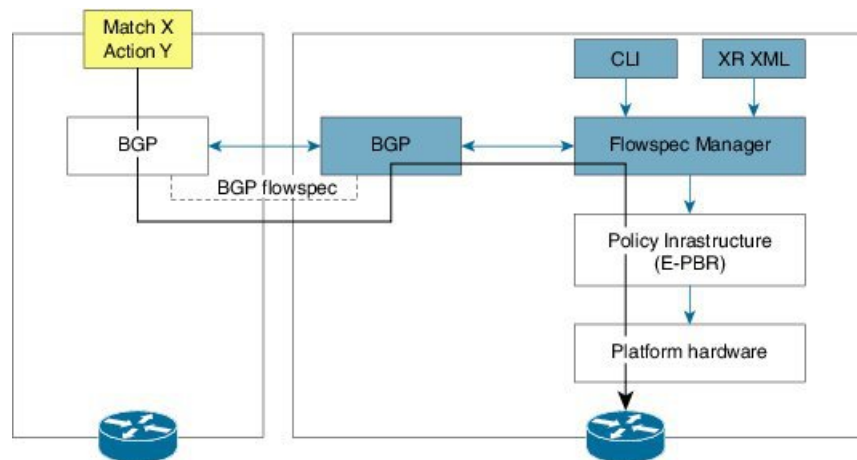

Here, the Controller on the left-hand side injects the flowspec NRLI, and the client on the right-hand side receives the information, sends it to the flowspec manager, configures the ePBR (Enhanced Policy-based Routing) infrastructure, which in turn programs the hardware from the underlying platform in use.

BGP Flowspec Controller

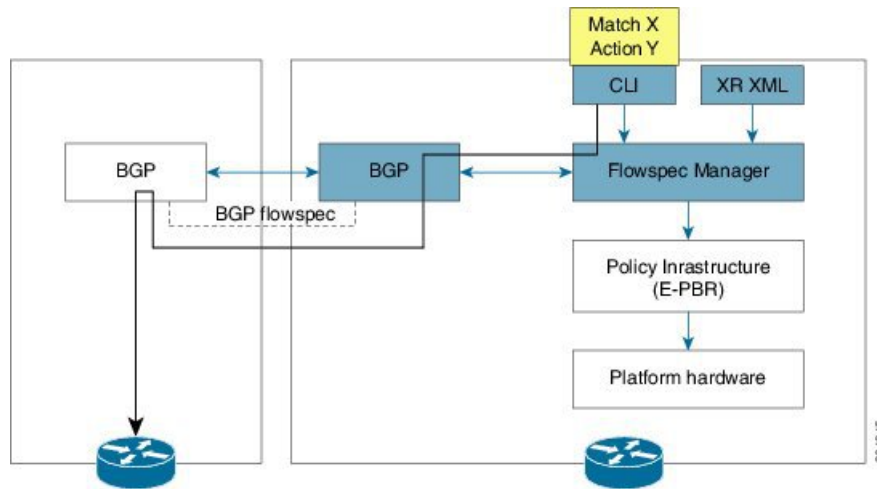

The Controller is configured using CLI to provide an entry for NRLI injection.

Configure BGP Flowspec

The following sections show how to configure BGP Flowspec feature.

Figure 8: BGP Flowspec

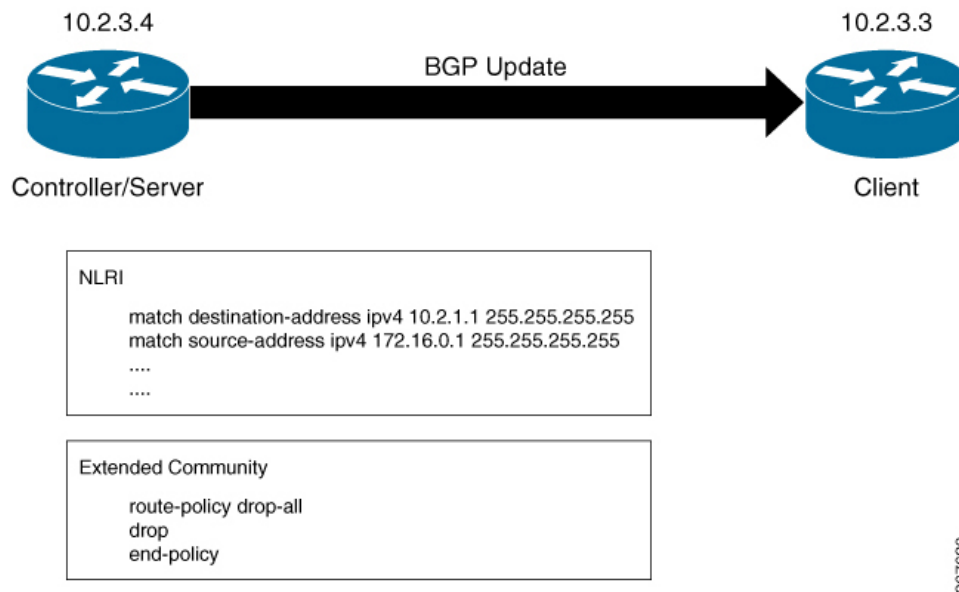

The controller or the server with IP address 10.2.3.4 sends the Flowspec NLRI to the client with IP address 10.2.3.3. The NLRI consists of matching criteria, the client processes based on this criteria. Traffic is dropped or accepted based on the configured criteria.

The following section describes how you can configure BGP Flowspec on the client:

```
/* Enable flowspec processing with IPv6 traffic */
Router# hw-module profile flowspec v6-enable
```

```
/*Configure BGP Flowspec */
Router(config)# flowspec
Router(config-flowspec)# address-family ipv4
Router(config-flowspec-af)# local-install interface-all
Router(config-flowspec-af)# exit
Router(config-flowspec)# address-family ipv6
Router(config-flowspec-af)# local-install interface-all
Router(config-flowspec-af)# exit

/* Configure the policy to accept all presented routes without modifying the routes */
Router(config)# route-policy pass-all
Router(config)# pass
Router(config)# end-policy

/* Configure the policy to reject all presented routes without modifying the routes */
Router(config)# route-policy drop-all
Router(config)# drop
Router(config)# end-policy

/* Configure BGP towards flowspec server */
Router(config)# router bgp 1
Router(config-bgp)# nsr
Router(config-bgp)# bgp router-id 10.2.3.3
Router(config-bgp)# address-family ipv4 flowspec
Router(config-bgp-af)# exit
Router(config-bgp)# address-family ipv6 flowspec
Router(config-bgp-af)# exit
Router(config-bgp)# neighbor 10.2.3.4
Router(config-bgp-nbr)# remote-as 1
Router(config-bgp-nbr)# address-family ipv4 flowspec

Router(config-bgp-nbr-af)# route-policy pass-all in
Router(config-bgp-nbr-af)# route-policy drop-all out
Router(config-bgp-af)# exit
Router(config-bgp-nbr)# address-family ipv6 flowspec

Router(config-bgp-nbr-af)# route-policy pass-all in
Router(config-bgp-nbr-af)# route-policy drop-all out
Router(config-bgp-nbr-af)# exit
Router(config-bgp-nbr)# update-source Loopback0

/* Define VRF to redirect the traffic */
Router(config)# vrf vrf1
Router(config-vrf)# address-family ipv4 unicast
Router(config-vrf-af)# import route-target
Router(config-vrf-import-rt)# 4787:13
Router(config-vrf-import-rt)# exit
Router(config-vrf-af)# export route-target
Router(config-vrf-export-rt)# 4787:13
Router(config-vrf-export-rt)# exit
Router(config-vrf-af)# exit
Router(config-vrf)# address-family ipv6 unicast
Router(config-vrf-af)# import route-target
Router(config-vrf-import-rt)# 4787:13
Router(config-vrf-import-rt)# exit
Router(config-vrf-af)# exit
Router(config-vrf-af)# export route-target
Router(config-vrf-export-rt)# 4787:13
Router(config-vrf-export-rt)# exit
Router(config-vrf-af)# exit

/* Define static route to forward redirected traffic under VRF
```

```

for traffic destination in any host under destination 10.0.0.0/8 */
Router(config)# router static
Router(config-static)# vrf vrf1
Router(config-static-vrf)# address-family ipv4 unicast
Router(config-static-vrf-af)# 10.0.0.0/8 200.255.55.2

/* Disable BGP Flowspec */
Router(config)# interface bundle-ether 3.1
Router(config-subif)# ipv4 flowspec disable
Router(config-subif)# ipv6 flowspec disable

```

The following section describes how you can configure BGP Flowspec on the server:

```

/* Configure the policy to accept all presented routes without modifying the routes */
Router(config)# route-policy pass-all
Router(config)# pass
Router(config)# end-policy

/* Configure the policy to reject all presented routes without modifying the routes */
Router(config)# route-policy drop-all
Router(config)# drop
Router(config)# end-policy

/* Configure BGP towards flowspec client */
Router(config)# router bgp 1
Router(config-bgp)# nsr
Router(config-bgp)# bgp router-id 10.2.3.4
Router(config-bgp)# address-family ipv4 flowspec
Router(config-bgp-af)# exit
Router(config-bgp)# address-family ipv6 flowspec
Router(config-bgp-af)# exit
Router(config-bgp)# neighbor 10.2.3.3
Router(config-bgp-nbr)# remote-as 1
Router(config-bgp-nbr)# address-family ipv4 flowspec

Router(config-bgp-nbr-af)# route-policy pass-all in
Router(config-bgp-nbr-af)# route-policy pass-all out
Router(config-bgp-nbr-af)# exit
Router(config-bgp-nbr)# update-source Loopback0

/* Configure IPv4 flowspec to be advertised to client. Define traffic classes. */
Router(config)# class-map type traffic match-all ipv4_fragment
Router(config-cmap)# match destination-address ipv4 10.2.1.1 255.255.255.255
Router(config-cmap)# match source-address ipv4 172.16.0.1 255.255.255.255
Router(config-cmap)# match packet length 700
Router(config-cmap)# match dscp af21
Router(config-cmap)# match fragment-type is-fragment
Router(config-cmap)# end-class-map

Router(config)# class-map type traffic match-all ipv4_icmp
Router(config-cmap)# match destination-address ipv4 10.2.1.1 255.255.255.255
Router(config-cmap)# match source-address ipv4 172.16.0.1 255.255.255.255
Router(config-cmap)# match packet length 700
Router(config-cmap)# match dscp af21
Router(config-cmap)# match fragment-type is-fragment
Router(config-cmap)# match ipv4 icmp-type 3
Router(config-cmap)# match ipv4 icmp-code 2
Router(config-cmap)# end-class-map

/* Define a policy map and associate it with traffic classes.

Router(config)# policy-map type pbr scale_ipv4

```



```

Router(config-pmap)# class type traffic ipv4_fragment
Router(config-pmap-c)# drop
Router(config-pmap-c)# exit
Router(config-pmap)# class type traffic ipv4_icmp
Router(config-pmap-c)# police rate 1 mbps
Router(config-pmap-c)# set dscp cs2
Router(config-pmap-c)# redirect nexthop route-target 4787:13
Router(config-pmap-c)# exit
Router(config-pmap)# class type traffic class-default
Router(config-pmap-c)# end-policy-map

Router(config)# flowspec
Router(config)# address-family ipv4
Router(config-af)# service-policy type pbr scale_ipv4

/* Configure IPv6 flowspec to be advertised to client. Define traffic classes. */
Router(config)# class-map type traffic match-all ipv6_tcp
Router(config-cmap)# match destination-address ipv6 70:1:1::5a/128
Router(config-cmap)# match source-address ipv4 ipv6 80:1:1::5a/128
Router(config-cmap)# match protocol tcp
Router(config-cmap)# match destination-port 22
Router(config-cmap)# match source-port 4000
Router(config-cmap)# match tcp-flag 0x10
Router(config-cmap)# match packet length 300
Router(config-cmap)# match dscp af12
Router(config-cmap)# match fragment-type is-fragment
Router(config-cmap)# end-class-map

Router(config)# class-map type traffic match-all ipv6_icmp
Router(config-cmap)# match destination-address ipv6 70:2:1::1/128
Router(config-cmap)# match source-address ipv4 ipv6 80:2:1::1/128
Router(config-cmap)# match packet length 800
Router(config-cmap)# match dscp af22
Router(config-cmap)# match ipv6 icmp-type 4
Router(config-cmap)# match ipv6 icmp-code 1
Router(config-cmap)# end-class-map

/* Define a policy map and associate it with traffic classes.

Router(config)# policy-map type pbr scale_ipv6
Router(config-pmap)# class type traffic ipv6_tcp
Router(config-pmap-c)# police rate 1 mbps
Router(config-pmap-c)# set dscp cs1
Router(config-pmap-c)# redirect ipv6 nexthop 202:158:2::1
Router(config-pmap-c)# exit
Router(config-pmap)# class type traffic ipv6_icmp
Router(config-pmap-c)# police rate 1 mbps
Router(config-pmap-c)# set dscp cs3
Router(config-pmap-c)# redirect nexthop route-target 4787:13
Router(config-pmap-c)# exit
Router(config-pmap)# class type traffic class-default
Router(config-pmap-c)# end-policy-map

Router(config)# flowspec
Router(config)# address-family ipv6
Router(config-af)# service-policy type pbr scale_ipv6

```

Running Configuration

```

/* Client-side configuration */
hw-module profile flowspec v6-enable

```

```

flowspec
  address-family ipv4
    local-install interface-all
  !
  address-family ipv6
    local-install interface-all
  !
  !
  route-policy pass-all
  pass
  end-policy
  !
  route-policy drop-all
  drop
  end-policy
  !
router bgp 1
  nsr
  bgp router-id 10.2.3.3
  address-family ipv4 flowspec
  !
  address-family ipv6 flowspec
  !
  neighbor 10.2.3.4
    remote-as 1
    address-family ipv4 flowspec
      route-policy pass-all in
      route-policy drop-all out
    !
    address-family ipv6 flowspec
      route-policy pass-all in
      route-policy drop-all out
    !
  update-source Loopback0
  !
  !
vrf vrf1
  address-family ipv4 unicast
    import route-target
      4787:13
    !
    export route-target
      4787:13
    !
  !
  address-family ipv6 unicast
    import route-target
      4787:13
    !
    export route-target
      4787:13
    !
  !
  !
router static
  vrf vrf1
  address-family ipv4 unicast
    10.0.0.0/8 200.255.55.2
  !
  !
  !/* Disable the flowspec. This is optional configuration */
  interface Bundle-Ether3.1
    ipv4 flowspec disable

```

```
    ipv6 flowspec disable
    !

    /* Server-side Configuration */
    route-policy pass-all
        pass
    end-policy
    !

    route-policy drop-all
        drop
    end-policy
    !

    router bgp 1
        nsr
        bgp router-id 10.2.3.4
        address-family ipv4 flowspec
        !
        address-family ipv6 flowspec
        !
        neighbor 10.2.3.3
            remote-as 1
            address-family ipv4 flowspec
                route-policy drop-all in
                route-policy pass-all out
            exit
        update-source Loopback0
        !
    !

    class-map type traffic match-all ipv4_fragment
        match destination-address ipv4 10.2.1.1 255.255.255.255
        match source-address ipv4 172.16.0.1 255.255.255.255
        match packet length 700
        match dscp af21
        match fragment-type is-fragment
    end-class-map
    !

    class-map type traffic match-all ipv4_icmp
        match destination-address ipv4 10.2.1.1 255.255.255.255
        match source-address ipv4 172.16.0.1 255.255.255.255
        match packet length 700
        match dscp af21
        match fragment-type is-fragment
        match ipv4 icmp-type 3
        match ipv4 icmp-code 2
    end-class-map
    !

    policy-map type pbr scale_ipv4
        class type traffic ipv4_fragment
            drop
        !
        class type traffic ipv4_icmp
            police rate 1 mbps
            !
            set dscp cs2
            redirect nexthop route-target 4787:13
        !
        class type traffic class-default
    !
```

```

    end-policy-map
    !

    flowspec
    address-family ipv4
    service-policy type pbr scale_ipv4
    !
    !
class-map type traffic match-all ipv6_tcp
 match destination-address ipv6 70:1:1::5a/128
 match source-address ipv6 80:1:1::5a/128
 match protocol tcp
 match destination-port 22
 match source-port 4000
 match tcp-flag 0x10
 match packet length 300
 match dscp af12
 end-class-map
 !

class-map type traffic match-all ipv6_icmp
 match destination-address ipv6 70:2:1::1/128
 match source-address ipv6 80:2:1::1/128
 match packet length 800
 match dscp af22
 match ipv6 icmp-type 4
 match ipv6 icmp-code 1
 end-class-map
 !

policy-map type pbr scale_ipv6
 class type traffic ipv6_tcp
  police rate 1 mbps
  !
  set dscp cs1
  redirect ipv6 nexthop 202:158:2::1
  !
 class type traffic ipv6_icmp
  police rate 1 mbps
  !
  set dscp cs3
  redirect nexthop route-target 4787:13
  !
 class type traffic class-default
  !
 !

flowspec
 address-family ipv6
 service-policy type pbr scale_ipv6
 !
 !

```

Verification

The following show output displays the status of the flowspec from the client side.

```

Router# show bgp ipv4 flowspec
GP router identifier 202.158.0.1, local AS number 4787
BGP generic scan interval 60 secs
Non-stop routing is enabled
BGP table state: Active
Table ID: 0x0   RD version: 7506
BGP main routing table version 7506

```

```

BGP NSR Initial initsync version 130 (Reached)
BGP NSR/ISSU Sync-Group versions 7506/0
BGP scan interval 60 secs

Status codes: s suppressed, d damped, h history, * valid, > best
                i - internal, r RIB-failure, S stale, N Nexthop-discard
Origin codes: i - IGP, e - EGP, ? - incomplete
  Network      Next Hop      Metric LocPrf Weight Path
*>iDest:10.1.1.1/32,Proto:=6,DPort:=80,SPort:=3000,Length:=200,DSCP:=10/176
                0.0.0.0                10      0 ?
*>iDest:10.1.1.2/32,Proto:=6,DPort:=80,SPort:=3000,Length:=200,DSCP:=10/176
                0.0.0.0                10      0 ?
*>iDest:10.1.1.3/32,Proto:=6,DPort:=80,SPort:=3000,Length:=200,DSCP:=10/176
                0.0.0.0                10      0 ?
*>iDest:10.1.1.4/32,Proto:=6,DPort:=80,SPort:=3000,Length:=200,DSCP:=10/176
                0.0.0.0                10      0 ?
*>iDest:10.1.1.5/32,Proto:=6,DPort:=80,SPort:=3000,Length:=200,DSCP:=10/176
                0.0.0.0                10      0 ?

Router# show bgp ipv6 flowspec
BGP router identifier 202.158.0.1, local AS number 4787
BGP generic scan interval 60 secs
Non-stop routing is enabled
BGP table state: Active
Table ID: 0x0  RD version: 1503
BGP main routing table version 1504
BGP NSR Initial initsync version 2 (Reached)
BGP NSR/ISSU Sync-Group versions 1504/0
BGP scan interval 60 secs

Status codes: s suppressed, d damped, h history, * valid, > best
                i - internal, r RIB-failure, S stale, N Nexthop-discard
Origin codes: i - IGP, e - EGP, ? - incomplete
  Network      Next Hop      Metric LocPrf Weight Path
*>iDest:70:1:1::1/0-128,Source:80:1:1::1/0-128,NH:=6,DPort:=22,SPort:=4000,TCPFflags:=0x10,Length:=300,DSCP:=12/464
                202:158:2::1                100      0 i
*>iDest:70:1:1::2/0-128,Source:80:1:1::2/0-128,NH:=6,DPort:=22,SPort:=4000,TCPFflags:=0x10,Length:=300,DSCP:=12/464
                202:158:2::1                100      0 i
*>iDest:70:1:1::3/0-128,Source:80:1:1::3/0-128,NH:=6,DPort:=22,SPort:=4000,TCPFflags:=0x10,Length:=300,DSCP:=12/464
                202:158:2::1                100      0 i
*>iDest:70:1:1::4/0-128,Source:80:1:1::4/0-128,NH:=6,DPort:=22,SPort:=4000,TCPFflags:=0x10,Length:=300,DSCP:=12/464
                202:158:2::1                100      0 i
*>iDest:70:1:1::5/0-128,Source:80:1:1::5/0-128,NH:=6,DPort:=22,SPort:=4000,TCPFflags:=0x10,Length:=300,DSCP:=12/464
                202:158:2::1                100      0 i

Router# show bgp vpv4 flowspec
BGP router identifier 202.158.0.1, local AS number 4787
BGP generic scan interval 60 secs
Non-stop routing is enabled
BGP table state: Active
Table ID: 0x0  RD version: 0
BGP main routing table version 5
BGP NSR Initial initsync version 3 (Reached)
BGP NSR/ISSU Sync-Group versions 5/0
BGP scan interval 60 secs

Status codes: s suppressed, d damped, h history, * valid, > best
                i - internal, r RIB-failure, S stale, N Nexthop-discard
Origin codes: i - IGP, e - EGP, ? - incomplete

```

```

Network          Next Hop          Metric LocPrf Weight Path
Route Distinguisher: 202.158.0.1:0 (default for vrf customer_1)
*>iDest:202.158.3.2/32,Source:202.158.1.2/32/96
                0.0.0.0                100      0 i
Route Distinguisher: 202.158.0.2:1
*>iDest:202.158.3.2/32,Source:202.158.1.2/32/96
                0.0.0.0                100      0 i

```

Processed 2 prefixes, 2 paths

```

Router# show bgp vpnv6 flowspec
BGP router identifier 202.158.0.1, local AS number 4787
BGP generic scan interval 60 secs
Non-stop routing is enabled
BGP table state: Active
Table ID: 0x0   RD version: 0
BGP main routing table version 5
BGP NSR Initial initsync version 4 (Reached)
BGP NSR/ISSU Sync-Group versions 5/0
BGP scan interval 60 secs

```

Status codes: s suppressed, d damped, h history, * valid, > best
i - internal, r RIB-failure, S stale, N Nexthop-discard
Origin codes: i - IGP, e - EGP, ? - incomplete

```

Network          Next Hop          Metric LocPrf Weight Path
Route Distinguisher: 202.158.0.1:0 (default for vrf customer_1)
*>iDest:200:158:3::2/0-128,Source:200:158:1::2/0-128,NH:=6,DPort:=22,SPort:=4000,Length:=300,DSCP:=12/440
                0.0.0.0                100      0 i
Route Distinguisher: 202.158.0.2:1
*>iDest:200:158:3::2/0-128,Source:200:158:1::2/0-128,NH:=6,DPort:=22,SPort:=4000,Length:=300,DSCP:=12/440
                0.0.0.0                100      0 i

```

Processed 2 prefixes, 2 paths

```

Router# show bgp ipv6 flowspec summary
BGP router identifier 202.158.0.1, local AS number 4787
BGP generic scan interval 60 secs
Non-stop routing is enabled
BGP table state: Active
Table ID: 0x0   RD version: 1503
BGP main routing table version 1504
BGP NSR Initial initsync version 2 (Reached)
BGP NSR/ISSU Sync-Group versions 1504/0
BGP scan interval 60 secs

```

BGP is operating in STANDALONE mode.

```

Process          RcvTblVer   bRIB/RIB   LabelVer   ImportVer   SendTblVer   StandbyVer
Speaker          1504        1504        1504        1504        1504        1504

Neighbor        Spk   AS  MsgRcvd  MsgSent   TblVer  InQ  OutQ  Up/Down   St/PfxRcd
200.255.1.5     0  4787    6957    2957     1504    0    0  04:48:02    0
200.255.1.6     0 50011    3015    3010         0    0    0  05:27:50  (NoNeg)
202.158.2.1     0  4787    1548    1648     1504    0    0    1d01h      750 <-- this
many flowspecs were received from server
202.158.3.1     0  4787    1683    1644     1504    0    0    1d01h      751
202.158.4.1     0  4787    1543    1649     1504    0    0    1d01h      0

```

sh bgp vpnv4 flowspec summary

```

BGP router identifier 202.158.0.1, local AS number 4787
BGP generic scan interval 60 secs
Non-stop routing is enabled
BGP table state: Active
Table ID: 0x0 RD version: 0
BGP main routing table version 5
BGP NSR Initial initsync version 3 (Reached)
BGP NSR/ISSU Sync-Group versions 5/0
BGP scan interval 60 secs

```

BGP is operating in STANDALONE mode.

Process	RcvTblVer	bRIB/RIB	LabelVer	ImportVer	SendTblVer	StandbyVer
Speaker	5	5	5	5	5	5

Neighbor	Spk	AS	MsgRcvd	MsgSent	TblVer	InQ	OutQ	Up/Down	St/PfxRcd
202.158.2.1	0	4787	1549	1648	5	0	0	1d01h	1 <-- this
many flowspecs were received from server									
202.158.3.1	0	4787	1684	1644	5	0	0	1d01h	0
202.158.4.1	0	4787	1543	1649	5	0	0	1d01h	0

Router# **show bgp vpnv6 flowspec summary**

```

BGP router identifier 202.158.0.1, local AS number 4787
BGP generic scan interval 60 secs
Non-stop routing is enabled
BGP table state: Active
Table ID: 0x0 RD version: 0
BGP main routing table version 5
BGP NSR Initial initsync version 4 (Reached)
BGP NSR/ISSU Sync-Group versions 5/0
BGP scan interval 60 secs

```

BGP is operating in STANDALONE mode.

Process	RcvTblVer	bRIB/RIB	LabelVer	ImportVer	SendTblVer	StandbyVer
Speaker	5	5	5	5	5	5

Neighbor	Spk	AS	MsgRcvd	MsgSent	TblVer	InQ	OutQ	Up/Down	St/PfxRcd
202.158.2.1	0	4787	1549	1649	5	0	0	1d01h	1 <-- this
many flowspecs were received from server									
202.158.3.1	0	4787	1684	1645	5	0	0	1d01h	0
202.158.4.1	0	4787	1543	1650	5	0	0	1d01h	0

Router# **show flowspec ipv4 detail**

```

AFI: IPv4
Flow      :Dest:10.1.1.1/32,Proto:=6,DPort:=80,SPort:=3000,Length:=200,DSCP:=10
Actions   :Traffic-rate: 0 bps (bgp.1)
Statistics (packets/bytes)
  Matched      : 18174999/3707699796
  Transmitted  : 0/0
  Dropped     : 18174999/3707699796

```

Router# **show flowspec ipv6 detail**

```

AFI: IPv6
Flow      :Dest:70:1:1::1/0-128,Source:80:1:1::1/0-128,NH:=6,DPort:=22,SPort:=4000,TCPFlags:=0x10,Length:=300,DSCP:=12
Actions   :Traffic-rate: 1000000 bps DSCP: cs1 Nexthop: 202:158:2::1 (bgp.1)

```

```

Statistics                               (packets/bytes)
  Matched                               :          64091597/19483845488
  Transmitted                            :          33973978/10328089312
  Dropped                                :          30117619/9155756176

```

Router# **show flowspec vrf customer_1 ipv4 detail**

```

VRF: customer_1      AFI: IPv4
  Flow               :Dest:202.158.3.2/32,Source:202.158.1.2/32
  Actions            :Traffic-rate: 250000000 bps DSCP: cs6 Redirect: VRF dirty_dancing
Route-target: ASN2-4787:666 (bgp.1)
  Statistics          (packets/bytes)
  Matched             :          37260786850/4098686553500
  Transmitted         :          21304093027/2343450232970
  Dropped             :          15956693823/1755236320530

```

Router# **show flowspec vrf customer_1 ipv6 detail**

```

VRF: customer_1      AFI: IPv6
  Flow
:Dest:200:158:3::2/0-128,Source:200:158:1::2/0-128,NH:=6,DPort:=22,SPort:=4000,Length:=300,DSCP:=12

  Actions            :Traffic-rate: 250000000 bps DSCP: cs6 Redirect: VRF dirty_dancing
Route-target: ASN2-4787:666 (bgp.1)
  Statistics          (packets/bytes)
  Matched             :          16130480136/4903665961344
  Transmitted         :          8490755776/2581189755904
  Dropped             :          7639724360/2322476205440

```

Router# **show flowspec ipv4 nlri**

```

AFI: IPv4
  NLRI (hex)         :0x01204601010103810605815006910bb80a81c80b810a
  Actions            :Traffic-rate: 0 bps (bgp.1)

```

Router# **show flowspec ipv6 nlri**

```

AFI: IPv6
  NLRI (hex)
:0x01800000700001000100000000000000000102800000800001000100000000000000000103810605811606910fa00981100a91012c0b810c

  Actions            :Traffic-rate: 1000000 bps DSCP: cs1 Nexthop: 202:158:2::1 (bgp.1)

```

Router# **show flowspec vrf customer_1 ipv4 nlri**

```

VRF: customer_1      AFI: IPv4
  NLRI (hex)         :0x0120ca9e03020220ca9e0102
  Actions            :Traffic-rate: 250000000 bps DSCP: cs6 Redirect: VRF dirty_dancing
Route-target: ASN2-4787:666 (bgp.1)

```

Router# **show flowspec vrf customer_1 ipv6 nlri**

```

VRF: customer_1      AFI: IPv6
  NLRI (hex)
:0x018000020001580003000000000000000000000002028000020001580001000000000000000000203810605811606910fa00a91012c0b810c

  Actions            :Traffic-rate: 250000000 bps DSCP: cs6 Redirect: VRF dirty_dancing
Route-target: ASN2-4787:666 (bgp.1)

```

Router# **show policy-map transient type pbr**

```

policy-map type pbr __bgpfs_default_IPv4
  handle:0x36000004
  table description: L3 IPv4 and IPv6
  class handle:0x760013eb sequence 1024
    match destination-address ipv4 10.1.1.1 255.255.255.255
    match protocol tcp

```



```
match destination-port 80
match source-port 3000
match packet length 200
match dscp 10
drop
!
```



CHAPTER 3

BGP Dynamic Neighbors

Earlier, IOS-XR supported explicitly configured or static neighbor configuration. BGP dynamic neighbor support allows BGP peering to a group of remote neighbors that are defined by a range of IP addresses. Each range can be configured as a subnet IP address.

In larger BGP networks, implementing BGP dynamic neighbors can reduce the amount and complexity of CLI configuration and save CPU and memory usage. Both IPv4 and IPv6 peering are supported.

- [Configuring BGP Dynamic Neighbors using Address Range, on page 225](#)
- [Configuring BGP Dynamic Neighbors Using Address Range With Authentication, on page 226](#)
- [Maximum-peers and Idle-watch timeout, on page 227](#)

Configuring BGP Dynamic Neighbors using Address Range

The existing neighbor command is extended to accept a prefix instead of an address.

In the following task, Router B is configured as a remote BGP peer. After a subnet range is configured, a TCP session is initiated by Router B which has an IP address in the subnet range and a new BGP neighbor is dynamically established.

After the initial configuration of subnet ranges and activation of the peer neighbor, dynamic BGP neighbor creation does not require any further CLI configuration on the Router A.



Configuration

```
Router# configure
Router(config)# router bgp as-number
Router(config-bgp)# neighbor address prefix
Router(config-bgp-nbr)# remote-as as-number
Router(config-bgp-nbr)# update-source interface
Router(config-bgp-nbr)# address-family ipv4 unicast
Router# commit
```

Running Configuration

```
Router# show running-config router bgp

router bgp 100
address-family ipv4 unicast
```

```

!
neighbor 12.12.12.0/24
  remote-as 100
  update-source TenGigE0/0/0/5
  address-family ipv4 unicast
!
!
!

```

Configuring BGP Dynamic Neighbors Using Address Range With Authentication

The following task shows how to configure BGP dynamic neighbors using address range with Message Digest 5 (MD5) authentication.

```

Router# configure
Router(config)# router bgp as-number
Router(config-bgp)# neighbor address prefix
Router(config-bgp-nbr)# remote-as as-number
Router(config-bgp-nbr)# password {clear | encrypted} password
Router(config-bgp-nbr)# update-source interface
Router(config-bgp-nbr)# address-family ipv4 unicast
Router# commit

```

Running Configuration

```
Router# show running-config router bgp
```

```

router bgp 100
address-family ipv4 unicast
!
neighbor 12.12.12.0/24
  remote-as 100
  password encrypted 053816063349401D
  update-source TenGigE0/0/0/5
  address-family ipv4 unicast
!
!
!

```

Configuring EA Authentication

The following task shows how to configure the EA authentication.



Note Configuring EA authentication is a prerequisite for configuring BGP dynamic neighbors with EA authentication.

```

RP/0/RP0/CPU0:R1(config)# key chain bgp_ea
RP/0/RP0/CPU0:R1(config-bgp_ea)# key 1
RP/0/RP0/CPU0:R1(config-bgp_ea-1)# accept-lifetime 00:00:00 january 01 2019 infinite
RP/0/RP0/CPU0:R1(config-bgp_ea-1)# key-string bgp_ea_key
RP/0/RP0/CPU0:R1(config-bgp_ea-1)# send-lifetime 00:00:00 january 01 2019 infinite
RP/0/RP0/CPU0:R1(config-bgp_ea-1)# cryptographic-algorithm HMAC-SHA1-12
RP/0/RP0/CPU0:R1(config-bgp_ea-1)# root
RP/0/RP0/CPU0:R1(config)# commit
Sat Sep  5 10:30:37.219 UTC
RP/0/RP0/CPU0:R1(config)# show run key chain

```

```

Sat Sep  5 10:30:41.976 UTC
key chain bgp_ea
  key 1
    accept-lifetime 00:00:00 january 01 2019 infinite
    key-string password 01110114640E07302A4957
    send-lifetime 00:00:00 january 01 2019 infinite
    cryptographic-algorithm HMAC-SHA1-12
  !
!
RP/0/RP0/CPU0:R1# show install active summary
Sat Sep  5 10:36:51.537 UTC
Active Packages:   XR: 115   All: 1080
Label:             7.0.1

Optional Packages                               Version
-----
xr-bgp                                               7.0.1v1.0.0-1

```

The following task shows how to configure BGP dynamic neighbors using address range with EA authentication.

```

Router# configure
Router(config)# router bgp as-number
Router(config-bgp)# neighbor address prefix
Router(config-bgp-nbr)# remote-as as-number
Router(config-bgp-nbr)# keychain bgp_ea
Router(config-bgp-nbr)# address-family ipv4 unicast
Router(config-bgp-nbr)# route-policy name
Router(config-bgp-nbr)# route-policy name
Router# commit

```

Running Configuration

```

router bgp 100
neighbor 6.1.1.2
  remote-as 200
  keychain bgp_ea
  address-family ipv4 unicast
  route-policy bgp_policy in
  route-policy bgp_policy out
!

```

Maximum-peers and Idle-watch timeout

In the following task, **maximum-peers** and **idle-watch timeout** commands are configured for a remote BGP peer.

Configuration

```

Router# configure
Router(config)# router bgp as-number
Router(config-bgp)# neighbor address prefix
Router(config-bgp-nbr)# remote-as as-number
Router(config-bgp-nbr)# password {clear | encrypted} password
Router(config-bgp-nbr)# maximum-peers number
Router(config-bgp-nbr)# update-source interface
Router(config-bgp-nbr)# idle-watch-time number
Router(config-bgp-nbr)# address-family ipv4 unicast
Router# commit

```

Running Configuration

```
Router# show running-config router bgp
router bgp 100
address-family ipv4 unicast
!
neighbor 12.12.12.0/24
  remote-as 100
  password encrypted 053816063349401D
  maximum-peers 10
  update-source TenGigE0/0/0/5
  idle-watch-time 40
  address-family ipv4 unicast
!
!
!
```



CHAPTER 4

EVPN Virtual Private Wire Service (VPWS)

The EVPN-VPWS is a BGP control plane solution for point-to-point services. It implements the signaling and encapsulation techniques for establishing an EVPN instance between a pair of PEs. It has the ability to forward traffic from one network to another without MAC lookup. The use of EVPN for VPWS eliminates the need for signaling single-segment and multi-segment PWs for point-to-point Ethernet services.

EVPN-VPWS single homed technology works on IP and MPLS core; IP core to support BGP and MPLS core for switching packets between the endpoints.



Note Other than enabling RTC (route target constraint) with `address-family ipv4 rtfilter` command, there is no separate configuration needed to enable RTC for BGP EVPN.

- [Information About EVPN-VPWS Single Homed, on page 229](#)
- [Configuring L2VPN EVPN Address Family Under BGP, on page 230](#)
- [Configuring EVPN-VPWS, on page 231](#)
- [Configuring EVPN-VPWS: Example, on page 233](#)

Information About EVPN-VPWS Single Homed

The EVPN-VPWS single homed solution requires per EVI Ethernet Auto Discovery route. EVPN defines a new BGP Network Layer Reachability Information (NLRI) used to carry all EVPN routes. BGP Capabilities Advertisement used to ensure that two speakers support EVPN NLRI (AFI 25, SAFI 70) as per RFC 4760.

The architecture for EVPN VPWS is that the PEs run Multi-Protocol BGP in control-plane. The following image describes the EVPN-VPWS configuration:

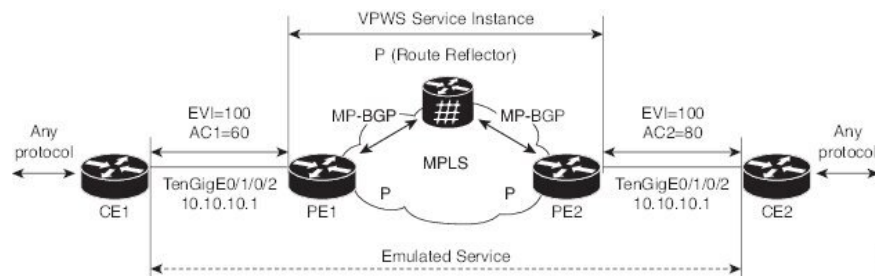

- The VPWS service on PE1 requires the following three elements to be specified at configuration time:

- The VPN ID (EVI)
- The local AC identifier (AC1) that identifies the local end of the emulated service.
- The remote AC identifier (AC2) that identifies the remote end of the emulated service.

PE1 allocates a MPLS label per local AC for reachability.

- The VPWS service on PE2 is set in the same manner as PE1. The three same elements are required and the service configuration must be symmetric.

PE2 allocates a MPLS label per local AC for reachability.

- PE1 advertise a single EVPN per EVI Ethernet AD route for each local endpoint (AC) to remote PEs with the associated MPLS label.

PE2 performs the same task.

- On reception of EVPN per EVI EAD route from PE2, PE1 adds the entry to its local L2 RIB. PE1 knows the path list to reach AC2, for example, next hop is PE2 IP address and MPLS label for AC2.

PE2 performs the same task.

Configuring L2VPN EVPN Address Family Under BGP

Perform this task to configure L2VPN EVPN address family under BGP.



Note Other than enabling RTC (route target constraint) with `address-family ipv4 rtfilter` command, there is no separate configuration needed to enable RTC for BGP EVPN.

SUMMARY STEPS

1. **configure**
2. **router bgp** *autonomous-system-number*
3. **address-family l2vpn evpn**
4. **neighbor** *ip-address*
5. **address-family l2vpn evpn**
6. Use the **commit** or **end** command.

DETAILED STEPS

Step 1 **configure**

Example:

```
RP/0/RP0/CPU0:router# configure
```

Enters the Global Configuration mode.

Step 2 **router bgp** *autonomous-system-number*

Example:

```
RP/0/RP0/CPU0:router(config)# router bgp 100
```

Enters router configuration mode for the specified routing process.

Step 3 address-family l2vpn evpn**Example:**

```
RP/0/RP0/CPU0:router(config-bgp)# address-family l2vpn evpn
RP/0/RP0/CPU0:router(config-bgp-af)# exit
```

Specifies the L2VPN address family and enters address family configuration mode.

Step 4 neighbor ip-address**Example:**

```
RP/0/RP0/CPU0:router(config-bgp)# neighbor 10.10.10.1
```

Adds the IP address of the neighbor in the specified autonomous system.

Step 5 address-family l2vpn evpn**Example:**

```
RP/0/RP0/CPU0:router(config-bgp-nbr)# address-family l2vpn evpn
```

Specifies the L2VPN address family of the neighbor and enters address family configuration mode.

Step 6 Use the **commit** or **end** command.

commit - Saves the configuration changes and remains within the configuration session.

end - Prompts user to take one of these actions:

- **Yes** - Saves configuration changes and exits the configuration session.
- **No** - Exits the configuration session without committing the configuration changes.
- **Cancel** - Remains in the configuration mode, without committing the configuration changes.

Configuring EVPN-VPWS

Perform this task to configure EVPN-VPWS.

SUMMARY STEPS

1. **configure**
2. **interface type** *interface-path-id*
3. **l2vpn**
4. **xconnect group** *group-name*

5. **p2p** *xconnect-name*
6. **interface** *type interface-path-id*
7. **neighbor evpn evi** *vpn-id***target** *ac-id* **source** *ac-id*
8. Use the **commit** or **end** command.

DETAILED STEPS

Step 1 **configure**

Example:

```
RP/0/RP0/CPU0:router# configure
```

Enters the Global Configuration mode.

Step 2 **interface type interface-path-id**

Example:

```
RP/0/RP0/CPU0:router(config)# interface TenGigE0/1/0/12
```

Enters interface configuration mode and configures an interface.

Step 3 **l2vpn**

Example:

```
RP/0/RP0/CPU0:router(config)# l2vpn
```

Enters Layer 2 VPN configuration mode.

Step 4 **xconnect group group-name**

Example:

```
RP/0/RP0/CPU0:router(config-l2vpn)# xconnect group evpn-vpws
```

Configures a cross-connect group name using a free-format 32-character string.

Step 5 **p2p xconnect-name**

Example:

```
RP/0/RP0/CPU0:router(config-l2vpn-xc)# p2p evpn1
```

Enters P2P configuration submode.

Step 6 **interface type interface-path-id**

Example:

```
RP/0/RP0/CPU0:router(config-l2vpn-xc-p2p)# interface TenGigE0/1/0/2
```

Specifies the interface type and instance.

Step 7 `neighbor evpn evi vpn-id target ac-id source ac-id`

Example:

```
RP/0/RP0/CPU0:router(config-l2vpn-xc-p2p)# neighbor evpn evi 100 target 12 source 10
```

Enables EVPN-VPWS endpoint on the p2p cross-connect.

Step 8 Use the **commit** or **end** command.

commit - Saves the configuration changes and remains within the configuration session.

end - Prompts user to take one of these actions:

- **Yes** - Saves configuration changes and exits the configuration session.
- **No** - Exits the configuration session without committing the configuration changes.
- **Cancel** - Remains in the configuration mode, without committing the configuration changes.

Configuring EVPN-VPWS: Example

The following example shows how to configure EVPN-VPWS service.

```
RP/0/RP0/CPU0:router# configure
RP/0/RP0/CPU0:router(config)# l2vpn
RP/0/RP0/CPU0:router(config-l2vpn)# xconnect group evpn-vpws
RP/0/RP0/CPU0:router(config-l2vpn-xc)# p2p evpn1
RP/0/RP0/CPU0:router(config-l2vpn-xc-p2p)# interface TenGigE0/1/0/12
RP/0/RP0/CPU0:router(config-l2vpn-xc-p2p)# neighbor evpn evi 100 target 12 source 10
```



CHAPTER 5

BGP-based VPWS Autodiscovery

An important aspect of VPN technologies is the ability of network devices to automatically signal to other devices about an association with a particular VPN. Autodiscovery refers to the process of finding all the provider edge routers that participates in a given VPWS instance.

The two primary functions of the VPWS control plane are: auto-discovery and signaling. Both of these functions are accomplished with a single BGP Update advertisement.

When a VPWS cross-connect is configured with BGP auto-discovery and signaling enabled, BGP needs to distribute NLRI for the xconnect with the PE as the BGP next-hop and appropriate CE-ID. Additionally, the cross-connect is associated with one or more BGP export Route Targets (RTs) that are also distributed (along with NLRI).

- [Configuring VPWS with BGP Autodiscovery and Signaling, on page 235](#)
- [VPWS with BGP Autodiscovery and BGP Signaling, on page 238](#)

Configuring VPWS with BGP Autodiscovery and Signaling

Perform this task to configure BGP-based autodiscovery and signaling.

SUMMARY STEPS

1. **configure**
2. **l2vpn**
3. **xconnect group** *group name*
4. **mp2mp** *vpws-domain name*
5. **vpn-id** *vpn-id*
6. **l2 encapsulation** **vlan**
7. **autodiscovery** **bgp**
8. **rd** { *as-number:nn* | *ip-address:nn* | **auto** }
9. **route-target** { *as-number:nn* | *ip-address:nn* | **export** | **import** }
10. **signaling-protocol** **bgp**
11. **ce-id** { *number* }
12. Use the **commit** or **end** command.

DETAILED STEPS

Step 1 **configure**

Example:

```
RP/0/RP0/CPU0:router# configure
```

Enters the global configuration mode.

Step 2 **l2vpn**

Example:

```
RP/0/RP0/CPU0:router(config)# l2vpn
```

Enters L2VPN configuration mode.

Step 3 **xconnect group** *group name*

Example:

```
RP/0/RP0/CPU0:router(config-l2vpn)# xconnect group gr1
```

Enters configuration mode for the named xconnect group.

Step 4 **mp2mp** *vpws-domain name*

Example:

```
RP/0/RP0/CPU0:router(config-l2vpn-xc)# mp2mp mp1
```

Enters configuration mode for the named vpws domain.

Step 5 **vpn-id** *vpn-id*

Example:

```
RP/0/RP0/CPU0:router(config-l2vpn-xc-m2mp)# vpn-id 100
```

Specifies the identifier for the VPWS service.

Step 6 **l2 encapsulation** *vlan*

Example:

```
RP/0/RP0/CPU0:router(config-l2vpn-xc-m2mp)#l2-encapsulation vlan
```

Configure the L2 encapsulation for this L2VPN MP2MP Instance.

Step 7 **autodiscovery** *bgp*

Example:

```
RP/0/RP0/CPU0:router(config-l2vpn-xc-mp2mp)#autodiscovery bgp
```

Enters BGP autodiscovery configuration mode where all BGP autodiscovery parameters are configured.

Step 8 **rd** { *as-number:nn* | *ip-address:nn* | **auto** }

Example:

```
RP/0/RP0/CPU0:router(config-l2vpn-xc-mp2mp-ad)# rd auto
```

Specifies the route distinguisher (RD).

Step 9 **route-target** { *as-number:nn* | *ip-address:nn* | **export** | **import** }

Example:

```
RP/0/RP0/CPU0:router(config-l2vpn-xc-mp2mp-ad)# route-target 500:99
```

Specifies the route target (RT).

Step 10 **signaling-protocol bgp**

Example:

```
RP/0/RP0/CPU0:router(config-l2vpn-xc-mp2mp-ad)# signaling-protocol bgp
```

Enables BGP signaling, and enters the BGP signaling configuration submenu where BGP signaling parameters are configured.

Step 11 **ce-id** { *number* }

Example:

```
RP/0/RP0/CPU0:router(config-l2vpn-xc-mp2mp-ad-sig)# ce-id 10
```

Specifies the local Customer Edge Identifier.

Step 12 Use the **commit** or **end** command.

commit - Saves the configuration changes and remains within the configuration session.

end - Prompts user to take one of these actions:

- **Yes** - Saves configuration changes and exits the configuration session.
 - **No** - Exits the configuration session without committing the configuration changes.
 - **Cancel** - Remains in the configuration mode, without committing the configuration changes.
-

VPWS with BGP Autodiscovery and BGP Signaling

The following figure illustrates an example of configuring and verifying VPWS with BGP autodiscovery (AD) and BGP Signaling.

Figure 9: VPLS with BGP autodiscovery and BGP signaling



Configuration at PE1:

```
l2vpn
  xconnect group gr1
  mp2mp mp1
  vpn-id 100
  l2 encapsulation vlan
  autodiscovery bgp
  rd auto
  route-target 2.2.2.2:100
  ! Signaling attributes
  signaling-protocol bgp
  ce-id 1
  interface GigabitEthernet0/1/0/1.1 remote-ce-id 2
```

Configuration at PE2:

```
l2vpn
  xconnect group gr1
  mp2mp mp1
  vpn-id 100
  l2 encapsulation vlan
  autodiscovery bgp
  rd auto
  route-target 2.2.2.2:100
  ! Signaling attributes
  signaling-protocol bgp
  ce-id 2
  interface GigabitEthernet0/1/0/2.1 remote-ce-id 1
```

Verification:

PE1:

```
PE1# show l2vpn discovery xconnect

Service Type: VPWS, Connected

List of VPNs (1 VPNs):

XC Group: gr1, MP2MP mp1

List of Local Edges (1 Edges):
```



```

Local Edge ID: 1, Label Blocks (1 Blocks)

Label base Offset  Size      Time Created
-----
16030      1          10          01/24/2009 21:23:04

Status Vector: 9f ff

```

List of Remote Edges (1 Edges):

```

Remote Edge ID: 2, NLRIs (1 NLRIs)

Label base Offset  Size      Peer ID      Time Created
-----
16045      1          10          1.1.1.1      01/24/2009 21:29:35

Status Vector: 7f ff

```

```

PE1# show l2vpn xconnect mp2mp detail

Group gr1, MP2MP mp1, state: up

VPN ID: 100

VPN MTU: 1500

L2 Encapsulation: VLAN

Auto Discovery: BGP, state is Advertised (Service Connected)

Route Distinguisher: (auto) 3.3.3.3:32770

Import Route Targets:

    2.2.2.2:100

Export Route Targets:

    2.2.2.2:100

Signaling protocol: BGP

CE Range: 10

...

Group gr1, XC mp1.1:2, state is up; Interworking none

Local CE ID: 1, Remote CE ID: 2, Discovery State: Advertised

AC: GigabitEthernet0/1/0/1.1, state is up

Type VLAN; Num Ranges: 1

VLAN ranges: [1, 1]

MTU 1500; XC ID 0x2000013; interworking none

```

```
PW: neighbor 1.1.1.1, PW ID 65538, state is up ( established )
```

```
PW class not set, XC ID 0x2000013
```

```
Encapsulation MPLS, Auto-discovered (BGP), protocol BGP
```

```

MPLS          Local                               Remote
-----

```

```
Label          16031                               16045
```

```
MTU            1500                               1500
```

```
Control word enabled                               enabled
```

```
PW type        Ethernet VLAN                       Ethernet VLAN
```

```
CE-ID          1                               2
-----
```

```
...
```

```
PE1# show bgp l2vpn vpws
```

```
BGP router identifier 3.3.3.3, local AS number 100
```

```
BGP generic scan interval 60 secs
```

```
BGP table state: Active
```

```
Table ID: 0x0
```

```
BGP main routing table version 913
```

```
BGP NSR converge version 3
```

```
BGP NSR converged
```

```
BGP scan interval 60 secs
```

```
Status codes: s suppressed, d damped, h history, * valid, > best
```

```

i - internal, S stale

```

```
Origin codes: i - IGP, e - EGP, ? - incomplete
```

```

Network          Next Hop          Rcvd Label      Local Label

```

```
Route Distinguisher: 1.1.1.1:32775
```

```
*>i2:1/32          1.1.1.1          16045           no-label
```

```
*>i3:1/32          1.1.1.1          16060           no-label
```

```
Route Distinguisher: 3.3.3.3:32770 (default for vrf gr1:mp1)
```

```
*> 1:1/32          0.0.0.0          no-label        16030
```

```
*>i2:1/32          1.1.1.1          16045           no-label
```

```
*>i3:1/32          1.1.1.1          16060          nolabel
```

```
Processed 5 prefixes, 5 paths
```

PE2:

```
PE2# show l2vpn discovery xconnect
```

```
Service Type: VPWS, Connected
```

```
List of VPNs (1 VPNs):
```

```
XC Group: gr1, MP2MP mp1
```

```
List of Local Edges (2 Edges):
```

```
Local Edge ID: 2, Label Blocks (1 Blocks)
```

```
Label base Offset  Size  Time Created
```

```
-----
16045      1      10      01/24/2009 21:09:14
```

```
Status Vector: 7f ff
```

```
Local Edge ID: 3, Label Blocks (1 Blocks)
```

```
Label base Offset  Size  Time Created
```

```
-----
16060      1      10      01/24/2009 21:09:14
```

```
Status Vector: 7f ff
```

```
List of Remote Edges (1 Edges):
```

```
Remote Edge ID: 1, NLRIs (1 NLRIs)
```

```
Label base Offset  Size  Peer ID  Time Created
```

```
-----
16030      1      10      3.3.3.3  01/24/2009 21:09:16
```

```
Status Vector: 9f ff
```

```
PE2# show l2vpn xconnect mp2mp detail
```

```
Group gr1, MP2MP mp1, state: up
```

```
VPN ID: 100
```

```
VPN MTU: 1500
```

```
L2 Encapsulation: VLAN
```

```
Auto Discovery: BGP, state is Advertised (Service Connected)
```

```
Route Distinguisher: (auto) 1.1.1.1:32775
```

```

Import Route Targets:
    2.2.2.2:100
Export Route Targets:
    2.2.2.2:100
Signaling protocol:BGP
    CE Range:10
...
Group gr1, XC mp1.2:1, state is up; Interworking none
Local CE ID: 2, Remote CE ID: 1, Discovery State: Advertised
AC: GigabitEthernet0/1/0/2.1, state is up
    Type VLAN; Num Ranges: 1
    VLAN ranges: [1, 1]
    MTU 1500; XC ID 0x2000008; interworking none
PW: neighbor 3.3.3.3, PW ID 131073, state is up ( established )
    PW class not set, XC ID 0x2000008
Encapsulation MPLS, Auto-discovered (BGP), protocol BGP
    MPLS          Local          Remote
    -----
    Label         16045          16031
    MTU           1500          1500
    Control word  enabled        enabled
    PW type       Ethernet VLAN  Ethernet VLAN
    CE-ID         2              1
    -----
...

PE2# show bgp l2vpn vpws

BGP router identifier 1.1.1.1, local AS number 100

BGP generic scan interval 60 secs

BGP table state: Active

Table ID: 0x0

BGP main routing table version 819

```

```
BGP NSR converge version 7
BGP NSR converged
BGP scan interval 60 secs
Status codes: s suppressed, d damped, h history, * valid, > best
                i - internal, S stale
Origin codes: i - IGP, e - EGP, ? - incomplete
  Network          Next Hop      Rcvd Label    Local Label
Route Distinguisher: 1.1.1.1:32775 (default for vrf gr1:mp1)
*>i1:1/32          3.3.3.3       16030         nolabel
*> 2:1/32          0.0.0.0       nolabel       16045
*> 3:1/32          0.0.0.0       nolabel       16060
Route Distinguisher: 3.3.3.3:32770
*>i1:1/32          3.3.3.3       16030         nolabel

Processed 4 prefixes, 4 paths
```



CHAPTER 6

Implementing Master Key Tuple Configuration

This feature specifies TCP Authentication Option (TCP-AO), which replaces the TCP MD5 option. TCP-AO uses the Message Authentication Codes (MACs), which provides the following:

- [Master Key Tuple Configuration, on page 245](#)
- [Keychain Configurations, on page 246](#)

Master Key Tuple Configuration

This feature specifies TCP Authentication Option (TCP-AO), which replaces the TCP MD5 option. TCP-AO uses the Message Authentication Codes (MACs), which provides the following:

- Protection against replays for long-lived TCP connections
- More details on the security association with TCP connections than TCP MD5
- A larger set of MACs with minimal other system and operational changes

TCP-AO is compatible with Master Key Tuple (MKT) configuration. TCP-AO also protects connections when using the same MKT across repeated instances of a connection. TCP-AO protects the connections by using traffic key that are derived from the MKT, and then coordinates changes between the endpoints.



Note TCPAO and TCP MD5 are never permitted to be used simultaneously. TCP-AO supports IPv6, and is fully compatible with the proposed requirements for the replacement of TCP MD5.

Cisco provides the MKT configuration via the following configurations:

- keychain configuration
- tcp ao keychain configuration

The system translates each key, such “key_id” that is under a keychain, as MKT. The keychain configuration owns part of the configuration like secret, lifetimes, and algorithms. While the “tcp ao keychain” mode owns the TCP AO-specific configuration for an MKT (send_id and receive_id).

Keychain Configurations

Configuration Guidelines

In order to run a successful configuration, ensure that you follow the configuration guidelines:

- An allowed value range for both Send_ID and Receive_ID is 0 to 255.
- You can link only one keychain to an application neighbor.
- Under the same keychain, if you configure the same send_id key again under the keys that have an overlapping lifetime, then the old key becomes unusable until you correct the configuration.
- The system sends a warning message in the following scenarios:
 - If there is a change in Send_ID or Receive_ID.
 - If the corresponding key is currently active, and is in use by some connection.
- BGP neighbor can ONLY use one of the authentication options:
 - MD5
 - EA
 - AO



Note If you configure one of these options, the system rejects the other authentication options during the configuration time.

Configuration Guidelines for TCP AO BGP Neighbor

The configuration guidelines are:

- Configure all the necessary configurations (key_string, MAC_algorithm, send_lifetime, accept_lifetime, send_id, receive_id) under key_id with the desired lifetime it wants to use the key_id for.
- Configure a matching MKT in the peer side with exactly same lifetime.
- Once a keychain-key is linked to tcp-ao, do not change the components of the key. If you want TCP to consider another key for use, you can configure that dynamically. Based on the 'start-time' of send lifetime, TCP AO uses the key.
- Send_ID and Receive_ID under a key_id (under a keychain) must have the same lifetime range. For example, send-lifetime==accept-lifetime.

TCP considers only expiry of send-lifetime to transition to next active key and it does not consider accept-lifetime at all.

- Do not configure a key with send-lifetime that is covered by another key's send-lifetime.

For example, if there is a key that is already configured with send-lifetime of “04:00:00 November 01, 2017 07:00:00 November 01, 2017” and the user now configures another key with send-lifetime of “05:00:00 November 01, 2017 06:00:00 November 01, 2017”, this might result into connection flap.

TCP AO tries to transition back to the old key once the new key is expired. However, if the new key has already expired, TCP AO can’t use it, which might result in segment loss and hence connection flap.

- Configure minimum of 15 minutes of overlapping time between the two overlapping keys. When a key expires, TCP does not use it and hence out-of-order segments with that key are dropped.
- We recommend configuring send_id and receive_id to be same for a key_id for simplicity.
- TCP does not have any restriction on the number of keychains and keys under a keychain. The system does not support more than 4000 keychains, any number higher than 4000 might result in unexpected behaviors.

Keychain Configuration

```
key chain <keychain_name>
  key <key_id>
    accept-lifetime <start-time> <end-time>
    key-string <master-key>
    send-lifetime <start-time> <end-time>
    cryptographic-algorithm <algorithm>
  !
!
```

TCP Configuration

TCP provides a new tcp ao submode that specifies SendID and ReceiveID per key_id per keychain.

```
tcp ao
  keychain <keychain_name1>
    key-id <key_id> send_id <0-255> receive_id <0-255>
  !
!
```

Example:

```
tcp ao
  keychain bgp_ao
    key 0 SendID 0 ReceiveID 0
    key 1 SendID 1 ReceiveID 1
    key 2 SendID 3 ReceiveID 4
  !
  keychain ldp_ao
    key 1 SendID 100 ReceiveID 200
    key 120 SendID 1 ReceiveID 1
  !
!
```

BGP Configurations

Applications like BGP provide the tcp-ao keychain and related information that it uses per neighbor. Following are the optional configurations per tcp-ao keychain:

- include-tcp-options
- accept-non-ao-connections

```

router bgp <AS-number>
neighbor <neighbor-ip>
  remote-as <remote-as-number>
  ao <keychain-name> include-tcp-options enable/disable <accept-ao-mismatch-connections>
!
```

XML Configurations

BGP XML

TCP-AO XML

```

<?xml version="1.0" encoding="UTF-8"?>
<Request>
  <Set>
    <Configuration>
      <IP_TCP>
        <AO>
          <Enable>
            true
          </Enable>
          <KeychainTable>
            <Keychain>
              <Naming>
                <Name> bgp_ao_xml </Name>
              </Naming>
              <Enable>
                true
              </Enable>
              <KeyTable>
                <Key>
                  <Naming>
                    <KeyID> 0 </KeyID>
                  </Naming>
                  <SendID> 0 </SendID>
                  <ReceiveID> 0 </ReceiveID>
                </Key>
              </KeyTable>
            </Keychain>
          </KeychainTable>
        </AO>
      </IP_TCP>
    </Configuration>
  </Set>
  <Commit/>
</Request>
```

Verification

To verify the keychain database, use the `show tcp authentication keychain <keychain-name>` command in EXEC mode. The following output displays all the keychain database details:

```

Keychain name: tcp_ao_keychain1, configured for tcp-ao
Desired key: 1
Detail of last notification from keychain:
Time: 'Jan 23 12:07:39.128', event: Config update, attr: Crypto algorithm, key: 1
Total number of keys: 1
Key details:
  Key ID: 1, Active, Valid
```

```
Active_state: 1, invalid_bits: 0x0, state: 0x110
Key is configured for tcp-ao, Send ID: 1, Receive ID: 1
Crypto algorithm: AES_128_CMAC_96, key string chksum: 00028222
Detail of last notification from keychain:
Time: 'Jan 23 12:07:39.128', event: Config update, attr: Crypto algorithm
No valid overlapping key
No keys invalidated
```

```
Total number of usable (Active & Valid) keys: 1
Keys: 1,
Total number of peers: 24
Peer details:
Peer: 0x7fc2f00242f8,
Current key not yet available
RNext key: 1
Traffic keys: send_non_SYN: 00000000, recv_non_SYN: 00000000

Peer: 0x7fc2f0024618,
Current key not yet available
RNext key: 1
Traffic keys: send_non_SYN: 00000000, recv_non_SYN: 00000000

Peer: 0x7fc2f00247f8,
Current key not yet available
RNext key: 1
Traffic keys: send_non_SYN: 00000000, recv_non_SYN: 00000000

Peer: 0x7fc2f00249d8,
Current key not yet available
RNext key: 1
Traffic keys: send_non_SYN: 00000000, recv_non_SYN: 00000000

Peer: 0x7fc2f0024bb8,
Current key not yet available
RNext key: 1
Traffic keys: send_non_SYN: 00000000, recv_non_SYN: 00000000

Peer: 0x7fc320037a08,
Current key not yet available
RNext key: 1
Traffic keys: send_non_SYN: 00000000, recv_non_SYN: 00000000

Peer: 0x7fc320037d78,
Current key not yet available
RNext key: 1
Traffic keys: send_non_SYN: 00000000, recv_non_SYN: 00000000

Peer: 0x7fc3200386d8,
Current key not yet available
RNext key: 1
Traffic keys: send_non_SYN: 00000000, recv_non_SYN: 00000000

Peer: 0x7fc3200388b8,
Current key not yet available
RNext key: 1
Traffic keys: send_non_SYN: 00000000, recv_non_SYN: 00000000

Peer: 0x7fc320038a98,
Current key not yet available
RNext key: 1
Traffic keys: send_non_SYN: 00000000, recv_non_SYN: 00000000

Peer: 0x7fc35000d3f8,
Current key: 1
```

```
Traffic keys: send_non_SYN: 00476017, rcv_non_SYN: ffd520f9
RNext key: 1
Traffic keys: send_non_SYN: 00000000, rcv_non_SYN: 00000000
Last 1 keys used:
  key: 1, time: Jan 23 12:07:41.953, reason: Peer requested rollover

Peer: 0x7fc320038e78,
Current key not yet available
RNext key: 1
Traffic keys: send_non_SYN: 00000000, rcv_non_SYN: 00000000

Peer: 0x7fc350012758,
Current key not yet available
RNext key: 1
Traffic keys: send_non_SYN: 00000000, rcv_non_SYN: 00000000

Peer: 0x7fc2f0026bc8,
Current key not yet available
RNext key: 1
Traffic keys: send_non_SYN: 00000000, rcv_non_SYN: 00000000

Peer: 0x7fc320048b08,
Current key: 1
Traffic keys: send_non_SYN: 004a05b5, rcv_non_SYN: fff639b2
RNext key: 1
Traffic keys: send_non_SYN: 00000000, rcv_non_SYN: 00000000
Last 1 keys used:
  key: 1, time: Jan 23 12:07:44.209, reason: No current key set

Peer: 0x7fc2f4008388,
Current key: 1
Traffic keys: send_non_SYN: 0029837c, rcv_non_SYN: 002af030
RNext key: 1
Traffic keys: send_non_SYN: 00000000, rcv_non_SYN: 00000000
Last 1 keys used:
  key: 1, time: Jan 23 12:07:44.229, reason: No current key set

Peer: 0x7fc350017198,
Current key: 1
Traffic keys: send_non_SYN: ffdb7322, rcv_non_SYN: fff1fb23
RNext key: 1
Traffic keys: send_non_SYN: 00000000, rcv_non_SYN: 00000000
Last 1 keys used:
  key: 1, time: Jan 23 12:07:45.419, reason: Peer requested rollover

Peer: 0x7fc320049098,
Current key: 1
Traffic keys: send_non_SYN: ffed0d67, rcv_non_SYN: ffe4f959
RNext key: 1
Traffic keys: send_non_SYN: 00000000, rcv_non_SYN: 00000000
Last 1 keys used:
  key: 1, time: Jan 23 12:07:55.180, reason: No current key set

Peer: 0x7fc32005d2a8,
Current key: 1
Traffic keys: send_non_SYN: 0021b461, rcv_non_SYN: fffe679e
RNext key: 1
Traffic keys: send_non_SYN: 00000000, rcv_non_SYN: 00000000
Last 1 keys used:
  key: 1, time: Jan 23 12:07:56.894, reason: No current key set

Peer: 0x7fc350035c88,
Current key: 1
Traffic keys: send_non_SYN: 00296167, rcv_non_SYN: fff1c236
```

```
RNext key: 1
Traffic keys: send_non_SYN: 00000000, recv_non_SYN: 00000000
Last 1 keys used:
  key: 1, time: Jan 23 12:07:57.859, reason: Peer requested rollover

Peer: 0x7fc35003fb18,
Current key: 1
Traffic keys: send_non_SYN: ffc95844, recv_non_SYN: ffcdfd4f
RNext key: 1
Traffic keys: send_non_SYN: 00000000, recv_non_SYN: 00000000
Last 1 keys used:
  key: 1, time: Jan 23 12:08:00.754, reason: Peer requested rollover

Peer: 0x7fc350049638,
Current key: 1
Traffic keys: send_non_SYN: 002ff48b, recv_non_SYN: ffbe71b9
RNext key: 1
Traffic keys: send_non_SYN: 00000000, recv_non_SYN: 00000000
Last 1 keys used:
  key: 1, time: Jan 23 12:08:10.014, reason: Peer requested rollover

Peer: 0x7fc350053928,
Current key: 1
Traffic keys: send_non_SYN: 00206914, recv_non_SYN: 001df9bc
RNext key: 1
Traffic keys: send_non_SYN: 00000000, recv_non_SYN: 00000000
Last 1 keys used:
  key: 1, time: Jan 23 12:08:12.422, reason: Peer requested rollover

Peer: 0x7fc2f401f3b8,
Current key not yet available
RNext key: 1
Traffic keys: send_non_SYN: 00000000, recv_non_SYN: 00000000

Total number of Send IDs: 1
Send ID details:
  SendID: 1, Total number of keys: 1
    Keys: 1,
Total number of Receive IDs: 1
Receive ID details:
  ReceiveID: 1, Total number of keys: 1
    Keys: 1,

RP/0/0/CPU0:stoat#
```



CHAPTER 7

BGP Prefix Independent Convergence

Table 10: Feature History Table

Feature Name	Release Information	Feature Description
BGP PIC Backup Path when the Primary Path is a Static Route with the next hop as an IP Address.	Release 7.5.1	<p>This feature is now supported on routers that have Cisco NC57 line cards installed and operate in native and compatibility mode.</p> <p>This feature enables BGP PIC backup path when the primary path is a static route with the next hop as an IP Address.</p>

Restrictions:

- Ensure that the Border Gateway Protocol (BGP) and the IP or Multiprotocol Label Switching (MPLS) network is up and running at the customer site that is connected to the provider site by more than one path (multihomed).
- BGP PIC does not support instances where the sum of number of primary paths and backup paths is greater than 2. Hence, only one primary path and one backup path are supported.
- BGP PIC does not work when Label Distribution Protocol (LDP) and Segment Routing (SR) are enabled in IGP.
- Ensure that the backup or alternate path has a unique next hop that is not the same as the next hop of the best path.
- As a best practice, enable the Bidirectional Forwarding Detection (BFD) protocol to quickly detect link failures.

BGP PIC: Export of Backup Path Agnostic to its Multipath Eligibility

The BGP PIC: Export of Backup Path Agnostic to its Multipath Eligibility feature improves BGP convergence after a network failure. This convergence applies to both core and edge failures. The BGP PIC pre-programs a backup path so that when a failure is detected, the backup path can immediately take over, thus enabling fast failover. This feature enables BGP PIC on VPNv4 with additional paths or when the multiple paths that are ineligible to be multipath are received from the same neighbor. For backup paths to be multipath eligible, all the following attributes in the backup paths must be the same: weight, local preference, autonomous system path, origin code, Multi Exit Discriminator (MED), and Interior Gateway Protocol (iGP) distance. Also, the

next hop router for each multipath must be different. This feature introduces flexibility to allow the import of backup paths to the VRF even if the said attributes are not the same.

Configuration Example

```
Router# router bgp 10
Router(config-bgp)# address-family vpv4 unicast
router(config-bgp-af)# export to vrf allow backup
```

Running Configuration

```
router bgp 10
 address-family vpv4 unicast
 export to vrf allow backup
```

- [Convergence for BGP Labeled Unicast PIC Edge, on page 254](#)
- [BGP PIC Implementation Considerations, on page 257](#)
- [Configure BGP PIC, on page 257](#)

Convergence for BGP Labeled Unicast PIC Edge

Table 11: Feature History Table

Feature Name	Release Information	Feature Description
Convergence for BGP Labeled Unicast PIC Edge	Release 7.7.1	<p>This feature improves the convergence time of BGP labeled unicast (LU) routes to subseconds when an ingress provider edge router fails or loses PE router connectivity, and another PE router needs to be connected. This feature minimizes traffic drops when the primary paths fail for the BGP LU routes.</p> <p>This feature is now supported on routers that have Cisco NC57 line cards installed and operate in native and compatibility mode`</p>

BGP Labeled Unicast (LU) PIC Edge feature enables you to create and store both the primary and backup path in the Routing Information Base (RIB), Forwarding Information Base (FIB), and Cisco Express Forwarding. When the router detects a failure, the backup or alternate path immediately takes over, thus this feature enables fast failover and convergence in subseconds.

For BGP LU PIC Edge to work, the edge iBGP devices, such as ingress PEs and Autonomous System Border Router (ASBR), must support BGP PIC and must receive backup BGP next hop.

The topology diagram given below illustrates the Convergence for BGP Labeled Unicast PIC Edge feature. The topology is explained as follows:

- The BGP LU PIC Edge feature is enabled on a provider edge router, PE1.
- PE1 learns the BGP LU prefix from the remote PE router, PE2.

- PE1 routes traffic through the Area Border Routers, ABR1, ABR2 and ABR3. If one of them fails, the preprogrammed backup of the failed ABR routes the traffic.
- PE1 routes traffic through the Area Border Routers, ABR1, ABR2 and ABR3.
- PE2 is marked as the backup or alternate next hop and is programmed into the FIB of PE1.
- When PE1 learns PE2 is not reachable through ABR1, it immediately changes the BGP next hop for the PE1's prefix to ABR2.
- The switchover occurs in less than a second regardless of the number of prefixes.
- Subsecond convergence occurs although updates to multiple BGP prefixes are pending.

Topology

Figure 10: BGP LU PIC Edge

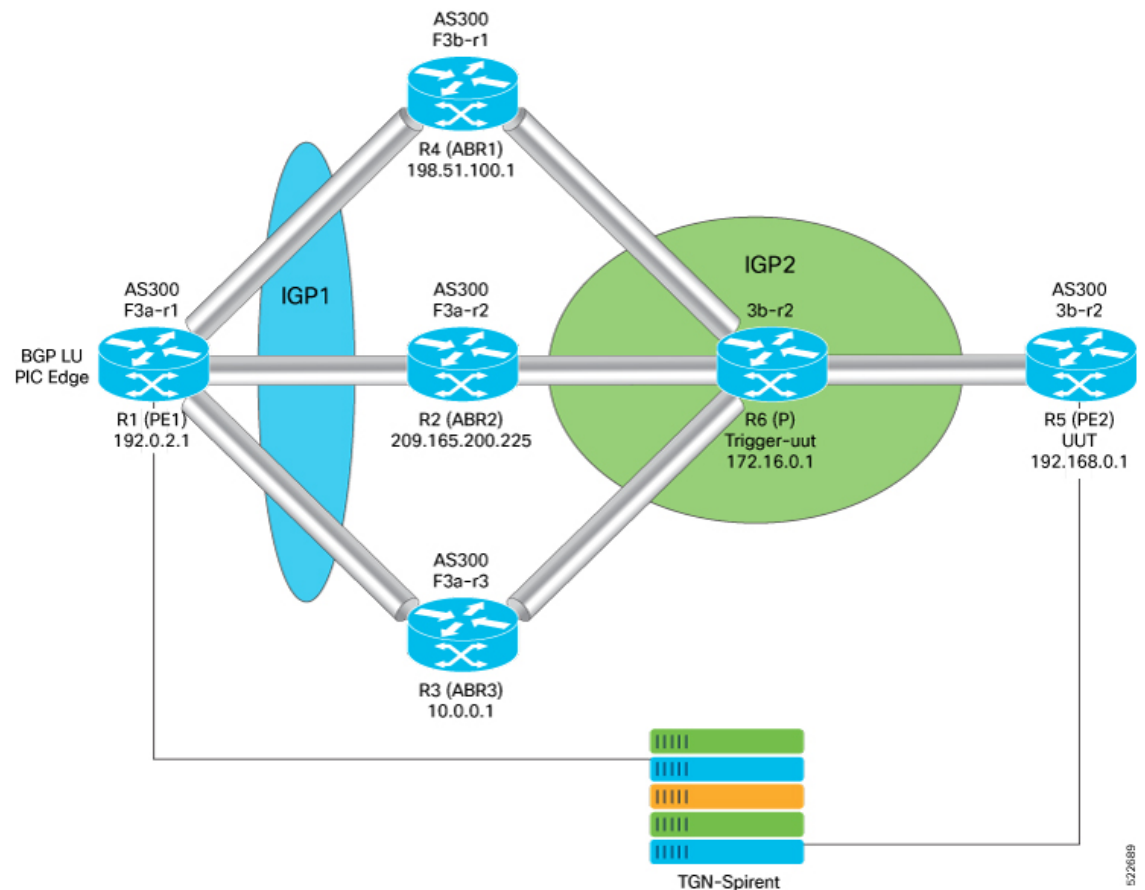

Guidelines and Limitations

This feature supports BGP multipaths that allows the router to install multiple internal BGP paths and multiple external BGP paths to the forwarding table. The multiple paths enable BGP to load balance traffic across multiple links.

The convergence time is independent of the BGP LU route scale.

Configure Convergence for BGP Labeled Unicast PIC Edge

Perform the following steps to configure Convergence for BGP Labeled Unicast PIC Edge:

- Configure BGP labeled unicast and attach route-policy to BGP address families.
- Configure BGP labeled unicast multipath and attach route-policy to BGP address families

```
Router(config)# route-policy BGP-PIC-EDGE
Router(config-rpl)# set path-selection backup 1 install
Router(config-rpl)# end-policy
Router(config)# end
Router(config)# router bgp 200
Router(config-bgp)# bgp router-id 10.0.0.1
Router(config-bgp)# address-family ipv4 unicast
Router(config-bgp-af)# additional-paths receive
Router(config-bgp-af)# additional-paths send
Router(config-bgp-af)# additional-paths selection route-policy BGP-PIC-EDGE
```

/*Perform the following steps to configure BGP labeled unicast multipath and attach route-policy to BGP address families: */

```
Router(config)# route-policy BGP-PIC-EDGE-MULTIPATH
Router(config-rpl)# set path-selection backup 1 install multipath-protect
Router(config)# end-policy
Router(config)# router bgp 200
Router(config)# bgp router-id 192.168.1.0
Router(config)# address-family ipv4 unicast
Router(config)# maximum-paths ibgp 2
Router(config)# additional-paths receive
Router(config)# additional-paths send
Router(config)# additional-paths selection route-policy BGP-PIC-EDGE-MULTIPATH
```

Running Configuration

```
route-policy BGP-PIC-EDGE
 set path-selection backup 1 install
 end-policy
router bgp 200
 bgp router-id 192.168.1.0
 address-family ipv4 unicast
 additional-paths receive
 additional-paths send
 additional-paths selection route-policy BGP-PIC-EDGE
```

```
route-policy BGP-PIC-EDGE-MULTIPATH
 set path-selection backup 1 install multipath-protect
 end-policy
router bgp 200
 bgp router-id 192.168.1.0
 address-family ipv4 unicast
 maximum-paths ibgp 2
 additional-paths receive
 additional-paths send
 additional-paths selection route-policy BGP-PIC-EDGE-MULTIPATH
```

Verification

Verify that the backup path is established.

```

Router# show cef 192.0.2.1/32
192.168.0.0/32, version 31, internal 0x5000001 0x40 (ptr 0x901d2370) [1], 0x0 (0x90d2beb8),
0xa08 (0x91c74378)
Prefix Len 32, traffic index 0, precedence n/a, priority 4
via 203.0.113.1/32, 3 dependencies, recursive [flags 0x6000] << Primary Path
  path-idx 0 NHID 0x0 [0x90319650 0x0]
  recursion-via-/32
  next hop 192.51.100.1/32 via 24006/0/21
  next hop 209.165.200.225/32 Hu0/0/0/25 labels imposed {24002 24000}
  next hop 10.0.0.1/32 Hu0/0/0/26 labels imposed {24002 24000}
via 203.0.113.2/32, 2 dependencies, recursive, backup [flags 0x6100] << Backup Path
  path-idx 1 NHID 0x0 [0x903197b8 0x0]
  recursion-via-/32
  next hop 209.165.200.225/32 via 24005/0/21
  next hop 192.51.100.1/32 Hu0/0/0/25 labels imposed {24001 24000}
  next hop 10.0.0.1/32 Hu0/0/0/26 labels imposed {24001 24000}

```

BGP PIC Implementation Considerations

- TE, SR-TE, SRv6, flex-LSP in the core are not supported.
- BGP PIC over BVI (core or edge) is not supported.
- For labelled BGP loopback peering, the system supports only one primary and one backup path. No support for BGP PIC multipath protect.
- PIC EDGE is supported for all services, such as IPv4, IPv6, VPNv4, VPNv6, 6PE, 6VPE, VPWS, VPLS, and EVPN, over labelled unicast address-family.
- The system supports BGP PIC multipath protect only for unlabelled BGP IPv4 and IPv6 address family. The support is for both loopback peering and interface peering mode.
- The system supports BGP PIC multipath protect only for labelled BGP in interface peering mode.
- Labelled BGP over IPv6 core BGP PIC is not supported.

Configure BGP PIC

Step 1 `cef encap-sharing disable`

Example:

```
RP/0/RP0/CPU0:router(config)# cef encap-sharing disable
```

By default, without primary and backup path installation in the hardware, IPv4, IPv6, 6PE (per-vrf), 6VPE (per-vrf/per-ce), L3VPN (per-vrf/per-ce) has good convergence.

When the mode is a per-prefix by default, BGP-PIC does not give good convergence, hence you must do hardware-assisted PIC. For this, configure the **cef encap-sharing disable** command in XR Config mode.

With hardware-assisted BGP PIC that is configured using the **cef encap-sharing disable** command, separate hardware resources (FEC/EEDB) are allocated for every prefix. Cisco recommends you to make sure that the router has sufficient hardware resources for the resource allocation.

Caution This CLI reprograms the CEF completely and impacts traffic. We recommend that you do it in the maintenance window.

Note The `cef encap-sharing disable` command does not take effect in the SRv6 core.

Step 2 `router bgp` *as-number*

Example:

```
RP/0/RP0/CPU0:router(config)# router bgp 100
```

Specifies the autonomous system number and enters the BGP configuration mode, allowing you to configure the BGP routing process.

Step 3 `address-family {vpnv4 unicast | vpnv6 unicast | ipv4 unicast | ipv6 unicast}`

Example:

```
RP/0/RP0/CPU0:router(config-bgp)# address-family ipv4 unicast
address-family ipv4 unicast
  additional-paths receive
  additional-paths selection route-policy backup 1
  allocate-label all
!
```

Step 4 `additional-paths selection route-policy` *route-policy-name*

Example:

```
RP/0/RP0/CPU0:router(config-bgp-af)# additional-paths selection route-policy ap1
```

Configures extra paths selection mode for a prefix.

Note Use the `additional-paths selection` command with an appropriate route-policy to calculate backup paths and to enable Prefix-Independent Convergence (PIC) functionality.

The route-policy configuration is a prerequisite for configuring the additional-paths selection mode for a prefix. This is an example route-policy configuration to use with additional-selection command:

```
route-policy ap1
  set path-selection backup 1 install
end-policy
```

Configure BGP PIC Multipath

For multipath bgp-pic, configure the `route-policy` as following:

```
route-policy ap1
  set path-select backup 1 install multipath-protect [advertise]
!
```