



## Configure Topology-Independent Loop-Free Alternate (TI-LFA)

---

Topology-Independent Loop-Free Alternate (TI-LFA) uses segment routing to provide link, node, and Shared Risk Link Groups (SRLG) protection in topologies where other fast reroute techniques cannot provide protection.

- Classic Loop-Free Alternate (LFA) is topology dependent, and therefore cannot protect all destinations in all networks. A limitation of LFA is that, even if one or more LFAs exist, the optimal LFA may not always be provided.
- Remote LFA (RLFA) extends the coverage to 90-95% of the destinations, but it also does not always provide the most desired repair path. RLFA also adds more operational complexity by requiring a targeted LDP session to the RLFAs to protect LDP traffic.

TI-LFA provides a solution to these limitations while maintaining the simplicity of the IPFRR solution.

The goal of TI-LFA is to reduce the packet loss that results while routers converge after a topology change due to a link or node failure. Rapid failure repair (< 50 msec) is achieved through the use of pre-calculated backup paths that are loop-free and safe to use until the distributed network convergence process is completed.

The optimal repair path is the path that the traffic will eventually follow after the IGP has converged. This is called the post-convergence path. This path is preferred for the following reasons:

- Optimal for capacity planning — During the capacity-planning phase of the network, the capacity of a link is provisioned while taking into consideration that such link will be used when other links fail.
- Simple to operate — There is no need to perform a case-by-case adjustments to select the best LFA among multiple candidate LFAs.
- Fewer traffic transitions — Since the repair path is equal to the post-convergence path, the traffic switches paths only once.

The following topology illustrates the optimal and automatic selection of the TI-LFA repair path.

Figure 1: TI-LFA Repair Path

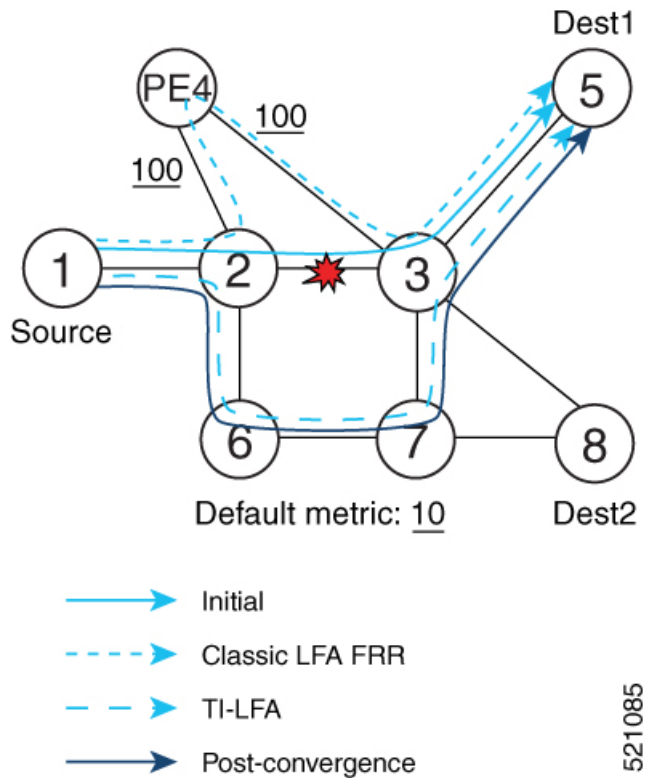

Node 2 protects traffic to destination Node 5.

With classic LFA, traffic would be steered to Node 4 after a failure of the protected link. This path is not optimal, since traffic is routed over edge node Node 4 that is connected to lower capacity links.

TI-LFA calculates a post-convergence path and derives the segment list required to steer packets along the post-convergence path without looping back.

In this example, if the protected link fails, the shortest path from Node 2 to Node 5 would be:

Node 2 → Node 6 → Node 7 → Node 3 → Node 5

Node 7 is the PQ-node for destination Node 5. TI-LFA encodes a single segment (prefix SID of Node 7) in the header of the packets on the repair path.

### TI-LFA Protection Types

TI-LFA supports the following protection:

- Link protection — The link is excluded during the post-convergence backup path calculation.
- Node protection — The neighbor node is excluded during the post convergence backup path calculation.
- Shared Risk Link Groups (SRLG) protection — SRLG refer to situations in which links in a network share a common fiber (or a common physical attribute). These links have a shared risk: when one link fails, other links in the group might also fail. TI-LFA SRLG protection attempts to find the post-convergence backup path that excludes the SRLG of the protected link. All local links that share any SRLG with the protecting link are excluded.

When you enable link protection, you can also enable node protection, SRLG protection, or both, and specify a tiebreaker priority in case there are multiple LFAs.

The following example illustrates the link, node, and SRLG protection types. In this topology, Node2 applies different protection models to protect traffic to Node7.

Figure 2: TI-LFA Protection Types

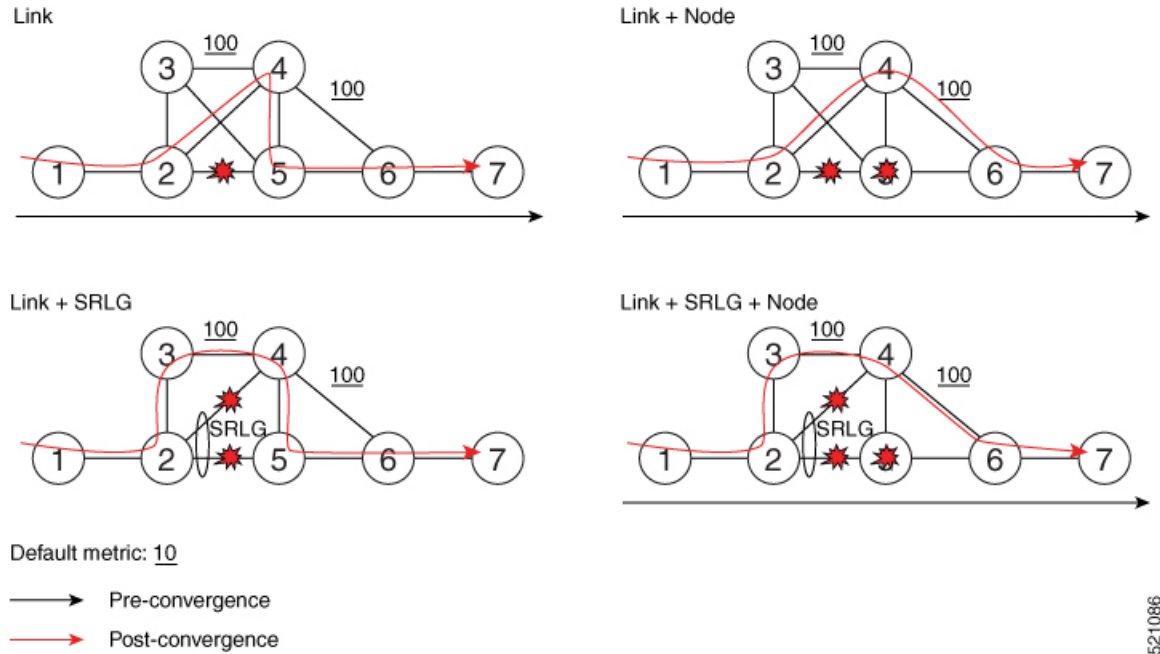

- [Limitations, on page 3](#)
- [Usage Guidelines and Limitations, on page 3](#)
- [Configuring TI-LFA for IS-IS, on page 4](#)
- [Configuring TI-LFA for OSPF, on page 6](#)
- [TI-LFA Node and SRLG Protection: Examples, on page 7](#)
- [Configuring Global Weighted SRLG Protection, on page 8](#)

521086

## Limitations

Only two backup labels are supported.

## Usage Guidelines and Limitations

The TI-LFA guidelines and limitations are listed below:

TI-LFA Functionality	IS-IS <sup>1</sup>	OSPFv2
<i>Protected Traffic Types</i>		
Protection for SR labeled traffic	Supported	Supported

TI-LFA Functionality	IS-IS <sup>1</sup>	OSPFv2
Protection of IPv4 unlabeled traffic	Supported (IS-ISv4)	Supported
Protection of IPv6 unlabeled traffic	Unsupported	N/A
<i>Protection Types</i>		
Link Protection	Supported	Supported
Node Protection	Supported	Supported
Local SRLG Protection	Supported	Supported
Weighted Remote SRLG Protection	Unsupported	Unsupported
Line Card Disjoint Protection	Unsupported	Unsupported
<i>Interface Types</i>		
Ethernet Interfaces	Supported	Supported
Ethernet Bundle Interfaces	Unsupported	Unsupported
TI-LFA over GRE Tunnel as Protecting Interface	Unsupported	Unsupported
<i>Additional Functionality</i>		
BFD-triggered	Unsupported	Unsupported
BFDv6-triggered	Unsupported	N/A
Prefer backup path with lowest total metric	Unsupported	Unsupported
Prefer backup path from ECMP set	Supported	Supported
Prefer backup path from non-ECMP set	Supported	Supported
Load share prefixes across multiple backups paths	Unsupported	Unsupported
Limit backup computation up to the prefix priority	Supported	Supported

<sup>1</sup> Unless specified, IS-IS support is IS-ISv4 and IS-ISv6

## Configuring TI-LFA for IS-IS

This task describes how to enable per-prefix Topology Independent Loop-Free Alternate (TI-LFA) computation to converge traffic flows around link, node, and SRLG failures.

### Before you begin

Ensure that the following topology requirements are met:

- Router interfaces are configured as per the topology.
- Routers are configured with IS-IS.

- Segment routing for IS-IS is configured. See [Enabling Segment Routing for IS-IS Protocol](#).

### Procedure

	Command or Action	Purpose
<b>Step 1</b>	<b>configure</b> <b>Example:</b> RP/0/RP0/CPU0:router# <b>configure</b>	Enters mode.
<b>Step 2</b>	<b>router isis <i>instance-id</i></b> <b>Example:</b> RP/0/RP0/CPU0:router(config)# <b>router isis</b> <b>1</b>	Enables IS-IS routing for the specified routing instance, and places the router in router configuration mode.  <b>Note</b> You can change the level of routing to be performed by a particular routing instance by using the <b>is-type</b> router configuration command.
<b>Step 3</b>	<b>interface <i>type interface-path-id</i></b> <b>Example:</b> RP/0/RP0/CPU0:router(config-isis)# <b>interface GigabitEthernet0/0/0/1</b>	Enters interface configuration mode.
<b>Step 4</b>	<b>address-family ipv4 [<i>unicast</i>]</b> <b>Example:</b> RP/0/RP0/CPU0:router(config-isis-if)# <b>address-family ipv4 unicast</b>	Specifies the IPv4 address family, and enters router address family configuration mode.
<b>Step 5</b>	<b>fast-reroute per-prefix</b> <b>Example:</b> RP/0/RP0/CPU0:router(config-isis-if-af)# <b>fast-reroute per-prefix</b>	Enables per-prefix fast reroute.
<b>Step 6</b>	<b>fast-reroute per-prefix ti-lfa</b> <b>Example:</b> RP/0/RP0/CPU0:router(config-isis-if-af)# <b>fast-reroute per-prefix ti-lfa</b>	Enables per-prefix TI-LFA fast reroute link protection.
<b>Step 7</b>	<b>fast-reroute per-prefix tiebreaker</b> <b>{<i>node-protecting</i>   <i>srlg-disjoint</i>} <i>index</i></b> <b><i>priority</i></b> <b>Example:</b>	Enables TI-LFA node or SRLG protection and specifies the tiebreaker priority. Valid <i>priority</i> values are from 1 to 255. The lower the <i>priority</i> value, the higher the priority of the rule. Link

	Command or Action	Purpose
	<pre>RP/0/RP0/CPU0:router(config-isis-if-af)# fast-reroute per-prefix tie-breaker srlg-disjoint index 100</pre>	<p>protection always has a lower priority than node or SRLG protection.</p> <p><b>Note</b> The same attribute cannot be configured more than once on an interface.</p> <p><b>Note</b> For IS-IS, TI-LFA node protection and SRLG protection can be configured on the interface or the instance.</p>

TI-LFA has been successfully configured for segment routing.

## Configuring TI-LFA for OSPF

This task describes how to enable per-prefix Topology Independent Loop-Free Alternate (TI-LFA) computation to converge traffic flows around link, node, and SRLG failures.



**Note** TI-LFA can be configured on the instance, area, or interface. When configured on the instance or area, all interfaces in the instance or area inherit the configuration.

### Before you begin

Ensure that the following topology requirements are met:

- Router interfaces are configured as per the topology.
- Routers are configured with OSPF.
- Segment routing for OSPF is configured. See [Enabling Segment Routing for OSPF Protocol](#).

### Procedure

	Command or Action	Purpose
<b>Step 1</b>	<p><b>configure</b></p> <p><b>Example:</b></p> <pre>RP/0/RP0/CPU0:router# configure</pre>	Enters mode.
<b>Step 2</b>	<p><b>router ospf process-name</b></p> <p><b>Example:</b></p> <pre>RP/0/RP0/CPU0:router(config)# router ospf 1</pre>	Enables OSPF routing for the specified routing process, and places the router in router configuration mode.

	Command or Action	Purpose
<b>Step 3</b>	<b>area</b> <i>area-id</i> <b>Example:</b> RP/0/RP0/CPU0:router (config-ospf) # <b>area</b> <b>1</b>	Enters area configuration mode.
<b>Step 4</b>	<b>interface</b> <i>type interface-path-id</i> <b>Example:</b> RP/0/RP0/CPU0:router (config-ospf-ar) # <b>interface GigabitEthernet0/0/0/1</b>	Enters interface configuration mode.
<b>Step 5</b>	<b>fast-reroute per-prefix</b> <b>Example:</b> RP/0/RP0/CPU0:router (config-ospf-ar-if) # <b>fast-reroute per-prefix</b>	Enables per-prefix fast reroute.
<b>Step 6</b>	<b>fast-reroute per-prefix ti-lfa</b> <b>Example:</b> RP/0/RP0/CPU0:router (config-ospf-ar-if) # <b>fast-reroute per-prefix ti-lfa</b>	Enables per-prefix TI-LFA fast reroute link protection.
<b>Step 7</b>	<b>fast-reroute per-prefix tiebreaker</b> <b>{ node-protecting   srlg-disjoint } index</b> <i>priority</i> <b>Example:</b> RP/0/RP0/CPU0:router (config-ospf-ar-if) # <b>fast-reroute per-prefix tie-breaker</b> <b>srlg-disjoint index 100</b>	Enables TI-LFA node or SRLG protection and specifies the tiebreaker priority. Valid <i>priority</i> values are from 1 to 255. The lower the <i>priority</i> value, the higher the priority of the rule. Link protection always has a lower priority than node or SRLG protection.  <b>Note</b> The same attribute cannot be configured more than once on an interface.

TI-LFA has been successfully configured for segment routing.

## TI-LFA Node and SRLG Protection: Examples

The following examples show the configuration of the tiebreaker priority for TI-LFA node and SRLG protection, and the behavior of post-convergence backup-path. These examples use OSPF, but the same configuration and behavior applies to IS-IS.

### Example: Enable link-protecting and node-protecting TI-LFA

```
router ospf 1
 area 1
  interface GigabitEthernet0/0/2/1
```

```

fast-reroute per-prefix
fast-reroute per-prefix ti-lfa
fast-reroute per-prefix tiebreaker node-protecting index 100

```

Both link-protecting and node-protecting TI-LFA backup paths will be computed. If the priority associated with the node-protecting tiebreaker is higher than any other tiebreakers, then node-protecting post-convergence backup paths will be selected, if it is available.

#### Example: Enable link-protecting and SRLG-protecting TI-LFA

```

router ospf 1
 area 1
  interface GigabitEthernet0/0/2/1
   fast-reroute per-prefix
   fast-reroute per-prefix ti-lfa
   fast-reroute per-prefix tiebreaker srlg-disjoint index 100

```

Both link-protecting and SRLG-protecting TI-LFA backup paths will be computed. If the priority associated with the SRLG-protecting tiebreaker is higher than any other tiebreakers, then SRLG-protecting post-convergence backup paths will be selected, if it is available.

#### Example: Enable link-protecting, node-protecting and SRLG-protecting TI-LFA

```

router ospf 1
 area 1
  interface GigabitEthernet0/0/2/1
   fast-reroute per-prefix
   fast-reroute per-prefix ti-lfa
   fast-reroute per-prefix tiebreaker node-protecting index 100
   fast-reroute per-prefix tiebreaker srlg-disjoint index 200

```

Link-protecting, node-protecting, and SRLG-protecting TI-LFA backup paths will be computed. If the priority associated with the node-protecting tiebreaker is highest from all tiebreakers, then node-protecting post-convergence backup paths will be selected, if it is available. If the node-protecting backup path is not available, SRLG-protecting post-convergence backup path will be used, if it is available.

## Configuring Global Weighted SRLG Protection

A shared risk link group (SRLG) is a set of links sharing a common resource and thus shares the same risk of failure. The existing loop-free alternate (LFA) implementations in interior gateway protocols (IGPs) support SRLG protection. However, the existing implementation considers only the directly connected links while computing the backup path. Hence, SRLG protection may fail if a link that is not directly connected but shares the same SRLG is included while computing the backup path. Global weighted SRLG protection feature provides better path selection for the SRLG by associating a weight with the SRLG value and using the weights of the SRLG values while computing the backup path.

To support global weighted SRLG protection, you need information about SRLGs on all links in the area topology. You can flood SRLGs for remote links using ISIS or manually configuring SRLGS on remote links.

#### Configuration Examples: Global Weighted SRLG Protection

There are three types of configurations that are supported for the global weighted SRLG protection feature.



- local SRLG with global weighted SRLG protection
- remote SRLG flooding
- remote SRLG static provisioning

This example shows how to configure the local SRLG with global weighted SRLG protection feature.

```
RP/0/RP0/CPU0:router(config)# srlg
RP/0/RP0/CPU0:router(config-srlg)# interface TenGigE0/0/0/0
RP/0/RP0/CPU0:router(config-srlg-if)# name group1
RP/0/RP0/CPU0:router(config-srlg-if)# exit
RP/0/RP0/CPU0:router(config-srlg)# interface TenGigE0/0/0/1
RP/0/RP0/CPU0:router(config-srlg-if)# name group1
RP/0/RP0/CPU0:router(config-srlg)# name group value 100
RP/0/RP0/CPU0:router(config)# router isis 1
RP/0/RP0/CPU0:router(config-isis)# address-family ipv4 unicast
RP/0/RP0/CPU0:router(config-isis-if-af)# fast-reroute per-prefix srlg-protection
weighted-global
RP/0/RP0/CPU0:router(config-isis-if-af)# fast-reroute per-prefix tiebreaker srlg-disjoint
index 1
RP/0/RP0/CPU0:router(config-isis)# interface TenGigE0/0/0/0
RP/0/RP0/CPU0:router(config-isis-if)# point-to-point
RP/0/RP0/CPU0:router(config-isis-if)# address-family ipv4 unicast
RP/0/RP0/CPU0:router(config-isis-if-af)# fast-reroute per-prefix
RP/0/RP0/CPU0:router(config-isis-if-af)# fast-reroute per-prefix ti-lfa
RP/0/RP0/CPU0:router(config-isis)# srlg
RP/0/RP0/CPU0:router(config-isis-srlg)# name group1
RP/0/RP0/CPU0:router(config-isis-srlg-name)# admin-weight 5000
```

This example shows how to configure the global weighted SRLG protection feature with remote SRLG flooding. The configuration includes local and remote router configuration. On the local router, the global weighted SRLG protection is enabled by using the **fast-reroute per-prefix srlg-protection weighted-global** command. In the remote router configuration, you can control the SRLG value flooding by using the **advertise application lfa link-attributes srlg** command. You should also globally configure SRLG on the remote router.

The local router configuration for global weighted SRLG protection with remote SRLG flooding is as follows:

```
RP/0/RP0/CPU0:router(config)# router isis 1
RP/0/RP0/CPU0:router(config-isis)# address-family ipv4 unicast
RP/0/RP0/CPU0:router(config-isis-if-af)# fast-reroute per-prefix srlg-protection
weighted-global
RP/0/RP0/CPU0:router(config-isis-if-af)# fast-reroute per-prefix tiebreaker srlg-disjoint
index 1
RP/0/RP0/CPU0:router(config-isis-if-af)# exit
RP/0/RP0/CPU0:router(config-isis)# interface TenGigE0/0/0/0
RP/0/RP0/CPU0:router(config-isis-if)# point-to-point
RP/0/RP0/CPU0:router(config-isis-if)# address-family ipv4 unicast
RP/0/RP0/CPU0:router(config-isis-if-af)# fast-reroute per-prefix
RP/0/RP0/CPU0:router(config-isis-if-af)# fast-reroute per-prefix ti-lfa
RP/0/RP0/CPU0:router(config-isis-if-af)# exit
RP/0/RP0/CPU0:router(config-isis)# srlg
RP/0/RP0/CPU0:router(config-isis-srlg)# name group1
RP/0/RP0/CPU0:router(config-isis-srlg-name)# admin-weight 5000
```

The remote router configuration for global weighted SRLG protection with remote SRLG flooding is as follows:

```
RP/0/RP0/CPU0:router(config)# srlg
RP/0/RP0/CPU0:router(config-srlg)# interface TenGigE0/0/0/0
```

```

RP/0/RP0/CPU0:router(config-srlg-if)# name group1
RP/0/RP0/CPU0:router(config-srlg-if)# exit
RP/0/RP0/CPU0:router(config-srlg)# interface TenGigE0/0/0/1
RP/0/RP0/CPU0:router(config-srlg-if)# name group1
RP/0/RP0/CPU0:router(config-srlg)# name group value 100
RP/0/RP0/CPU0:router(config-srlg)# exit
RP/0/RP0/CPU0:router(config)# router isis 1
RP/0/RP0/CPU0:(config-isis)# address-family ipv4 unicast
RP/0/RP0/CPU0:router(config-isis-af)# advertise application lfa link-attributes srlg

```

This example shows configuring the global weighted SRLG protection feature with static provisioning of SRLG values for remote links. You should perform these configurations on the local router.

```

RP/0/RP0/CPU0:router(config)# srlg
RP/0/RP0/CPU0:router(config-srlg)# interface TenGigE0/0/0/0
RP/0/RP0/CPU0:router(config-srlg-if)# name group1
RP/0/RP0/CPU0:router(config-srlg-if)# exit
RP/0/RP0/CPU0:router(config-srlg)# interface TenGigE0/0/0/1
RP/0/RP0/CPU0:router(config-srlg-if)# name group1
RP/0/RP0/CPU0:router(config-srlg)# name group value 100
RP/0/RP0/CPU0:router(config-srlg)# exit
RP/0/RP0/CPU0:router(config)# router isis 1
RP/0/RP0/CPU0:router(config-isis)# address-family ipv4 unicast
RP/0/RP0/CPU0:router(config-isis-if-af)# fast-reroute per-prefix srlg-protection
weighted-global
RP/0/RP0/CPU0:router(config-isis-if-af)# fast-reroute per-prefix tiebreaker srlg-disjoint
index 1
RP/0/RP0/CPU0:router(config-isis)# interface TenGigE0/0/0/0
RP/0/RP0/CPU0:router(config-isis-if)# point-to-point
RP/0/RP0/CPU0:router(config-isis-if)# address-family ipv4 unicast
RP/0/RP0/CPU0:router(config-isis-if-af)# fast-reroute per-prefix
RP/0/RP0/CPU0:router(config-isis-if-af)# fast-reroute per-prefix ti-lfa
RP/0/RP0/CPU0:router(config-isis)# srlg
RP/0/RP0/CPU0:router(config-isis-srlg)# name group1
RP/0/RP0/CPU0:router(config-isis-srlg-name)# admin-weight 5000
RP/0/RP0/CPU0:router(config-isis-srlg-name)# static ipv4 address 10.0.4.1 next-hop ipv4
address 10.0.4.2
RP/0/RP0/CPU0:router(config-isis-srlg-name)# static ipv4 address 10.0.4.2 next-hop ipv4
address 10.0.4.1

```