



User Guide for Cisco Prime Access Registrar, 6.0

Release 6.0
January 15, 2013

Americas Headquarters
Cisco Systems, Inc.
170 West Tasman Drive
San Jose, CA 95134-1706
USA
<http://www.cisco.com>
Tel: 408 526-4000
800 553-NETS (6387)
Fax: 408 527-0883

Text Part Number: OL-26928-01

THE SPECIFICATIONS AND INFORMATION REGARDING THE PRODUCTS IN THIS MANUAL ARE SUBJECT TO CHANGE WITHOUT NOTICE. ALL STATEMENTS, INFORMATION, AND RECOMMENDATIONS IN THIS MANUAL ARE BELIEVED TO BE ACCURATE BUT ARE PRESENTED WITHOUT WARRANTY OF ANY KIND, EXPRESS OR IMPLIED. USERS MUST TAKE FULL RESPONSIBILITY FOR THEIR APPLICATION OF ANY PRODUCTS.

THE SOFTWARE LICENSE AND LIMITED WARRANTY FOR THE ACCOMPANYING PRODUCT ARE SET FORTH IN THE INFORMATION PACKET THAT SHIPPED WITH THE PRODUCT AND ARE INCORPORATED HEREIN BY THIS REFERENCE. IF YOU ARE UNABLE TO LOCATE THE SOFTWARE LICENSE OR LIMITED WARRANTY, CONTACT YOUR CISCO REPRESENTATIVE FOR A COPY.

The Cisco implementation of TCP header compression is an adaptation of a program developed by the University of California, Berkeley (UCB) as part of UCB's public domain version of the UNIX operating system. All rights reserved. Copyright © 1981, Regents of the University of California.

NOTWITHSTANDING ANY OTHER WARRANTY HEREIN, ALL DOCUMENT FILES AND SOFTWARE OF THESE SUPPLIERS ARE PROVIDED "AS IS" WITH ALL FAULTS. CISCO AND THE ABOVE-NAMED SUPPLIERS DISCLAIM ALL WARRANTIES, EXPRESSED OR IMPLIED, INCLUDING, WITHOUT LIMITATION, THOSE OF MERCHANTABILITY, FITNESS FOR A PARTICULAR PURPOSE AND NONINFRINGEMENT OR ARISING FROM A COURSE OF DEALING, USAGE, OR TRADE PRACTICE.

IN NO EVENT SHALL CISCO OR ITS SUPPLIERS BE LIABLE FOR ANY INDIRECT, SPECIAL, CONSEQUENTIAL, OR INCIDENTAL DAMAGES, INCLUDING, WITHOUT LIMITATION, LOST PROFITS OR LOSS OR DAMAGE TO DATA ARISING OUT OF THE USE OR INABILITY TO USE THIS MANUAL, EVEN IF CISCO OR ITS SUPPLIERS HAVE BEEN ADVISED OF THE POSSIBILITY OF SUCH DAMAGES.

Cisco and the Cisco logo are trademarks or registered trademarks of Cisco and/or its affiliates in the U.S. and other countries. To view a list of Cisco trademarks, go to this URL: www.cisco.com/go/trademarks. Third-party trademarks mentioned are the property of their respective owners. The use of the word partner does not imply a partnership relationship between Cisco and any other company. (1110R)

Any Internet Protocol (IP) addresses used in this document are not intended to be actual addresses. Any examples, command display output, and figures included in the document are shown for illustrative purposes only. Any use of actual IP addresses in illustrative content is unintentional and coincidental.

User Guide for Cisco Prime Access Registrar, 6.0
© 2013 Cisco Systems, Inc. All rights reserved.



CONTENTS

About This Guide	xxxiii
How This Book Is Organized	xxxiii
Obtaining Documentation and Submitting a Service Request	xxxv
Related Documentation	xxxv
Notices	xxxv
OpenSSL/Open SSL Project	xxxv
License Issues	xxxv

CHAPTER 1

Overview	1-1
Cisco Prime Access Registrar Hierarchy	1-2
UserLists and Groups	1-2
Profiles	1-3
Scripts	1-3
Services	1-3
Session Management Using Resource Managers	1-4
Cisco Prime Access Registrar Directory Structure	1-5
Program Flow	1-5
Scripting Points	1-6
Client Scripting	1-6
Client or NAS Scripting Points	1-6
Authentication and/or Authorization Scripting Points	1-7
Session Management	1-8
Failover by the NAS and Session Management	1-9
Cross Server Session and Resource Management	1-9
Script Processing Hierarchy	1-11
RADIUS Protocol	1-12
Steps to Connection	1-13
Types of RADIUS Messages	1-13
Packet Contents	1-14
The Attribute Dictionary	1-15
Proxy Servers	1-15
Service and Ports Used in Cisco Prime AR	1-16
Secure Shell Service	1-16
Ports	1-16

CHAPTER 2

Using the aregcmd Commands 2-1

- General Command Syntax 2-1
 - View-Only Administrator Mode 2-2
 - ViewOnly Property 2-3
 - Configuration Objects 2-3
 - aregcmd Command Performance 2-3
 - RPC Bind Services 2-4
- aregcmd Commands 2-4
 - add 2-5
 - cd 2-5
 - delete 2-6
 - exit 2-6
 - filter 2-6
 - find 2-6
 - help 2-7
 - insert 2-7
 - login 2-7
 - logout 2-7
 - ls 2-8
 - next 2-8
 - prev 2-8
 - pwd 2-8
 - query-sessions 2-9
 - quit 2-9
 - release-sessions 2-9
 - reload 2-10
 - reset-stats 2-10
 - save 2-10
 - set 2-11
 - start 2-12
 - stats 2-12
 - status 2-14
 - stop 2-14
 - tacacs-stats 2-14
 - tacacs-reset-stats 2-15
 - trace 2-15
 - trace-file-count 2-16
 - unset 2-16
 - validate 2-17

OpenSSL Commands	2-17
ecparam	2-17
req	2-17
ca	2-17
aregcmd Command Logging	2-18
aregcmd Command Line Editing	2-18
aregcmd Error Codes	2-19

CHAPTER 3**Using the Graphical User Interface 3-1**

Launching the GUI	3-1
Disabling HTTP	3-2
Disabling HTTPS	3-2
Login Page	3-3
Logging In	3-3
Logging Out	3-4
Common Methodologies	3-4
Filtering Records	3-5
Editing Records	3-5
Deleting Records	3-6
Setting Record Limits per Page	3-6
Performing Common Navigations	3-6
Relocating Records	3-7
Dashboard	3-8
Sessions	3-9
Configuring Cisco Prime Access Registrar	3-9
RADIUS	3-10
Setting Up or Changing the Radius Properties	3-11
Profiles	3-11
Adding Profile Details	3-12
UserGroups	3-12
Adding UserGroup Details	3-14
UserList	3-14
Adding UserList Details	3-15
Users	3-15
Adding User Details	3-17
Scripts	3-17
Adding Script Details	3-19
Policies	3-19
Adding Policy Details	3-19

- Services **3-20**
 - Simple Services **3-20**
 - ServiceWithRS **3-25**
 - PEAP Service **3-26**
 - EAP Service **3-29**
 - Diameter Service **3-38**
 - Adding Diameter Service Details **3-41**
- Replication **3-43**
 - Adding Replication Details **3-44**
 - Adding the Replication Member Details **3-44**
- RADIUS Dictionary **3-45**
 - Adding Radius Dictionary Details **3-45**
- Vendor Dictionary **3-46**
 - Adding Vendor Dictionary Details **3-47**
- Vendor Attributes **3-47**
 - Adding Vendor Attributes **3-48**
- Vendors **3-49**
 - Adding Vendor Details **3-49**
- Translations **3-50**
 - Adding Translation Details **3-51**
- Translation Groups **3-51**
 - Adding Translation Group Details **3-52**
- DIAMETER **3-52**
 - General **3-53**
 - SessionManagement **3-54**
 - Applications **3-55**
 - Commands **3-57**
- Advanced **3-58**
 - Default **3-59**
 - BackingStore/ServerParam **3-63**
 - RemoteSessionServer **3-67**
 - SNMP **3-69**
 - DDNS **3-71**
 - ODBC DataSources **3-72**
 - Log **3-74**
 - Ports **3-75**
 - Interfaces **3-76**
 - Attribute Groups **3-77**
- Rules **3-78**
 - Setting Rules **3-79**

Session Managers	3-79
Adding Session Manager Details	3-82
Resource Manager	3-82
Adding Resource Manager Details	3-90
Network Resources	3-90
Clients	3-91
Adding Client Details	3-94
Remote Servers	3-94
LDAP	3-95
LDAP Accounting	3-99
Domain Authentication	3-102
ODBC/OCI	3-104
ODBC/OCI-Accounting	3-107
Others	3-109
Administration	3-113
Administrators	3-114
Adding Administrator Details	3-114
Statistics	3-115
Resetting Server Statistics	3-117
Diameter Statistics	3-118
TACACS Statistics	3-121
Backup and Restore	3-122
License Upload	3-123
Read-Only GUI	3-124

CHAPTER 4**Cisco Prime Access Registrar Server Objects** 4-1

Radius	4-2
UserLists	4-3
Users	4-4
HiddenAttributes Property	4-4
UserGroups	4-5
Policies	4-5
Clients	4-6
Vendors	4-9
Scripts	4-10
Services	4-11
Types of Services	4-12
Domain Authentication	4-13

EAP Services	4-13
File	4-14
Group	4-15
Java	4-16
LDAP	4-17
Local	4-17
ODBC	4-18
ODBC-Accounting	4-19
Prepaid Services	4-19
RADIUS	4-19
Radius Query	4-20
RADIUS-Session	4-24
Rex	4-24
WiMAX	4-25
Diameter	4-25
M3UA	4-30
Session Managers	4-31
Session Creation	4-35
Session Notes	4-35
Soft Group Session Limit	4-36
Session Correlation Based on User-Defined Attributes	4-37
Resource Managers	4-37
Types of Resource Managers	4-38
Gateway Subobject	4-39
Group-Session-Limit	4-39
Home-Agent	4-39
Home-Agent-IPv6	4-39
IP-Dynamic	4-39
IP-Per-NAS-Port	4-40
IPX-Dynamic	4-40
Session-Cache	4-41
Subnet-Dynamic	4-41
User-Session-Limit	4-42
USR-VPN	4-42
Dynamic-DNS	4-42
Remote-IP-Dynamic	4-43
Remote-User-Session-Limit	4-43
Remote-Group-Session-Limit	4-43
Remote-Session-Cache	4-43

Profiles	4-43
Attributes	4-44
Translations	4-44
TranslationGroups	4-45
Remote Servers	4-45
Types of Protocols	4-46
Domain Authentication	4-47
Dynamic DNS	4-48
LDAP	4-49
Map-Gateway	4-52
Sigtran	4-53
ODBC	4-54
ODBC-Accounting	4-55
OCI	4-56
OCI-Accounting	4-56
Prepaid-CRB	4-57
Prepaid-IS835C	4-57
RADIUS	4-57
SIGTRAN-M3UA	4-58
Rules	4-58
Advanced	4-58
RemoteODBCSessionServer	4-70
Using the RequireNASsBehindProxyBelnClientList Property	4-71
Advance Duplicate Detection Feature	4-72
Invalid EAP Packet Processing	4-72
Ports	4-73
Interfaces	4-73
Reply Messages	4-73
Attribute Dictionary	4-75
Types	4-75
Vendor Attributes	4-76
SNMP	4-76
Diameter	4-77
Configuring Diameter TransportManagement Properties	4-78
Configuring Diameter SessionManagement	4-80
Configuring Diameter Application	4-81
Configuring Diameter Commands	4-82
Configuring Diameter Dictionary	4-88

CHAPTER 5

Using the radclient Command 5-1

- radclient Command Syntax 5-1
- Working with Packets 5-2
 - Creating Packets 5-2
 - Creating CHAP Access-Request Packets 5-3
 - Viewing Packets 5-3
 - Sending Packets 5-3
 - Creating Empty Packets 5-4
 - Setting Packet Fields 5-4
 - Reading Packet Fields 5-5
 - Deleting Packets 5-5
- Attributes 5-5
 - Creating Attributes 5-5
 - Setting Multivalued Attributes 5-6
 - Viewing Attributes 5-6
 - Getting Attribute Information 5-7
 - Deleting Attributes 5-7
 - Using the radclient Command 5-7
 - Example 1 5-7
 - Example 2 5-8
 - Example 3 5-9
- Using radclient Test Commands 5-10
 - radclient Variables 5-10
 - Using timetest 5-10
 - Using callsPerSecond 5-11
 - Additional radclient Variables 5-12

CHAPTER 6

Configuring Local Authentication and Authorization 6-1

- Configuring a Local Service and UserList 6-1
 - Configuring a Local Service 6-2
 - Configuring a Userlist 6-3
 - Configuring Cisco Prime Access Registrar to Use the Local Service For AA 6-3
 - Activating the Configuration 6-4
- Troubleshooting the Local Service and UserList Configuration 6-4
 - Verifying the Configuration 6-4
 - Configuring Return Attributes and Check-Items 6-6
 - Configuring Per User Return Attributes 6-6
 - Configuring Per User Check-Items 6-7
 - Verifying the Per User Return Attributes and Check-Items Configuration 6-7

Configuring Profiles to Group Attributes	6-8
Configuring Return Attributes and Check-Items Using UserGroup	6-9
Return Attribute Precedence	6-10
aregcmd Command Performance	6-10
UserDefined1 Property	6-11
Access-Request Logging	6-11

CHAPTER 7**RADIUS Accounting 7-1**

Understanding RADIUS Accounting	7-1
Setting Up Accounting	7-2
Accounting Log File Rollover	7-2
FilenamePrefix	7-3
MaxFileSize	7-3
MaxFileAge	7-4
RolloverSchedule	7-4
UseLocalTimeZone	7-5
Oracle Accounting	7-5
Configuring Oracle Accounting	7-6
ODBC-Accounting Service	7-6
ODBC RemoteServers	7-6
Configuration Examples	7-8
Packet Buffering	7-9
When Using Packet Buffering	7-10
With Packet Buffering Disabled	7-10
Dynamic SQL Feature	7-10
LDAP Accounting	7-10
Configuring LDAP Accounting	7-11
LDAP-Accounting Service	7-11
LDAP RemoteServers	7-12
Configuration Examples	7-14
Configuring the LDAP Service for Accounting	7-15
Configuring an LDAP-Accounting RemoteServer	7-16
Setting LDAP-Accounting As Accounting Service	7-18
MySQL Support	7-19
Configuring MySQL	7-19
Example Configuration	7-20
Proxying Accounting Records	7-20
Configuring the Local Cisco Prime Access Registrar Server	7-21
Configuring the Local Accounting Service	7-21

- Configuring the Remote Accounting Service 7-21
- Configuring the Group Accounting Service 7-22
- Configuring the RemoteServer Object 7-22
- Accounting Log Examples 7-23
 - Accounting-Start Packet 7-23
 - Accounting Stop Packet 7-23
 - Trace of Successful Accounting 7-23
- Sample Error Messages 7-24

CHAPTER 8

Diameter 8-1

- Before You Begin 8-2
- Diameter Server Startup Log 8-2
- Diameter Stack Level Messages 8-3
 - Capabilities Exchange Message 8-3
 - Watchdog Message 8-4
 - Terminating Diameter User Session 8-4
- Configuring Authentication and Authorization for Diameter 8-4
 - Configuring Local Authentication and Authorization 8-5
 - Configuring a Local Service and UserList 8-5
 - Configuring External Authentication Service 8-6
- Configuring Diameter Accounting 8-6
 - Understanding Diameter Accounting 8-7
 - Setting Up Local Accounting 8-7
 - Setting up Oracle Accounting 8-7
 - Diameter Accounting Log Examples 8-7
 - Accounting Event Packet 8-7
 - Accounting Start Packet 8-7
 - Account Interim Packet 8-8
 - Accounting Stop Packet 8-8
 - Trace of Successful Accounting 8-8
- Configuring the Diameter Application in Cisco Prime AR 8-9
 - Importing Application Specific Cisco AVPs to Cisco Prime AR Internal Database 8-9
 - Configuring the Transport Management Properties 8-10
 - Registering Applications IDs 8-11
 - Configuring the Diameter Peers 8-12
 - Configure the Diameter Service 8-13
- Writing Diameter Application in Cisco Prime AR 8-17
 - Configuring rex script/service for Diameter 8-17
 - Scripting in Diameter 8-18

Diameter Environment Variables	8-18
Sample rex script/service	8-19
Traces/Logs	8-20
Diameter Routing Agent	8-21
Diameter Relay Agent	8-21
Diameter Proxy Agent	8-22
RoundRobin	8-22
FailOver	8-23
IMSI Range Based	8-23
Configuring Diameter Proxy	8-23
Configuring Cisco Prime AR to Demultiplex the Diameter CCR-T	8-26
Traces/Logs	8-28
Writing Diameter Proxy Extension Scripts	8-30
Sample Diameter Proxy Extension Script	8-30
Traces/Logs	8-31
Importing Diameter Command Codes	8-32
Support for SCTP including Multihoming	8-32

CHAPTER 9**Extensible Authentication Protocols 9-1**

EAP-AKA	9-2
Configuring EAP-AKA	9-2
Testing EAP-AKA with radclient	9-5
EAP-FAST	9-6
Configuring EAP-FAST	9-6
EAP-FAST Keystores	9-10
Testing EAP-FAST with radclient	9-10
PAC Provisioning	9-11
Authentication	9-12
Parameters Used for Certificate-Based Authentication	9-12
radclient Command Reference	9-13
PAC—Credential Export Utility	9-15
PAC Export	9-15
PAC Display	9-16
Syntax Summary	9-16
EAP-GTC	9-16
Configuring EAP-GTC	9-16
Testing EAP-GTC with radclient	9-17
EAP-LEAP	9-18
Configuring EAP-LEAP	9-18

- EAP-MD5 **9-19**
 - Configuring EAP-MD5 **9-19**
- EAP-Negotiate **9-20**
 - Configuring EAP-Negotiate **9-20**
 - Negotiating PEAP Tunnel Services **9-21**
 - Testing EAP-Negotiate with radclient **9-21**
- EAP-MSChapV2 **9-21**
 - Configuring EAP-MSChapV2 **9-21**
 - Testing EAP-MSChapV2 with radclient **9-22**
- EAP-SIM **9-23**
 - Configuring EAP-SIM **9-23**
- EAP-Transport Level Security (TLS) **9-27**
 - Configuring EAP-TLS **9-27**
 - Testing EAP-TLS with RSA or ECC Certificate using radclient **9-30**
 - Testing EAP-TLS with Client Certificates **9-30**
- EAP-TTLS **9-30**
 - Configuring EAP-TTLS **9-31**
 - Creating an EAP-TTLS Service **9-31**
 - Configuring an EAP-TTLS Authentication Service **9-35**
 - Testing EAP-TTLS with radclient **9-38**
 - Testing EAP-TTLS Using Legacy Methods **9-39**
 - Testing EAP-TTLS Using EAP Methods **9-39**
 - rehash-ca-certs Utility **9-40**
- radclient Command Reference **9-40**
 - eap-trace **9-41**
 - tunnel **9-41**
- Protected EAP **9-42**
 - PEAP Version 0 **9-42**
 - Configuring PEAP Version 0 **9-42**
 - Testing PEAP Version 0 with radclient **9-46**
 - Testing PEAP Version 0 with Client Certificates **9-46**
 - PEAP Version 1 **9-47**
 - Configuring PEAP Version 1 **9-47**
 - Testing PEAP Version 1 with radclient **9-49**
 - Testing PEAP Version 1 with Client Certificates **9-50**
- How to Configure Oracle, Mysql Accounting with the Buffering Option Enabled **9-50**
 - To Select the SQL Statement in Run Time Accounting **9-50**
 - Query **9-50**
 - Insert **9-51**

Update	9-51
Delete	9-51
Configuring Oracle, Mysql Accounting	9-52
How Suffix and Prefix Rules Work with Cisco Prime AR	9-53
Configuring Prefix and Suffix Policies	9-53
CRL Support for Cisco Prime Access Registrar	9-54
Configuring Certificate Validation Using CRL	9-55
Using Intermediate Certificates in Cisco Prime AR	9-55

CHAPTER 10**Using WiMAX in Cisco Prime Access Registrar 10-1**

WiMAX - An Overview	10-1
WiMAX in Cisco Prime Access Registrar	10-2
Direct Interaction Between the ASN GW and Cisco Prime Access Registrar	10-3
Interaction Between ASN GW and Cisco Prime Access Registrar Through HA	10-5
Prepaid and Hot-Lining	10-6
Configuring WiMAX in Cisco Prime Access Registrar	10-6
Configuring the Resource Manager for WiMAX	10-7
Configuring the Session Manager for WiMAX	10-8
Configuring the Query Service for WiMAX	10-8
Configuring WiMAX	10-9
WiMAX - OMA-DM Provisioning Support with BEK key	10-11
WiMax Lawful Interception (LI) Support in Cisco Prime AR	10-12
Configuring WiMax-Lawful Intercept	10-15

CHAPTER 11**Using Extension Points 11-1**

Determining the Goal of the Script	11-1
Writing the Script	11-2
Choosing the Type of Script	11-3
Request Dictionary Script	11-3
Response Dictionary Script	11-4
Environment Dictionary Script	11-4
Adding the Script Definition	11-4
Adding the Example Script Definition	11-5
Choosing the Scripting Point	11-5
Testing the Script	11-6
About the Tcl/Tk 8.3 Engine	11-6
Cisco Prime Access Registrar Scripts	11-6
ACMEOutgoingScript	11-7

AltigaIncomingScript	11-8
AltigaOutgoingScript	11-8
ANAAAOutgoing	11-8
AscendIncomingScript	11-8
AscendOutgoingScript	11-8
AuthorizePPP	11-8
AuthorizeService	11-8
AuthorizeSLIP	11-9
AuthorizeTelnet	11-9
CabletronIncoming	11-9
CabletronOutgoing	11-9
CiscoIncoming	11-9
CiscoOutgoing	11-9
CiscoWithODAPIIncomingScript	11-9
ExecCLIDRule	11-10
ExecDNISRule	11-10
ExecFilterRule	11-10
ExecNASIPRule	11-10
ExecRealmRule	11-10
ExecTimeRule	11-10
LDAPOutage	11-11
MapSourceIPAddress	11-11
ParseAAALocal	11-11
ParseAAASRealm	11-11
ParseAAALocal	11-11
ParseAAASRealm	11-12
ParseProxyHints	11-12
ParseServiceAndAAALocalHints	11-12
ParseServiceAndAAASRealmHints	11-12
ParseServiceAndAAALocalHints	11-12
ParseServiceAndAAASRealmHints	11-12
ParseServiceAndProxyHints	11-13
ParseServiceHints	11-13
ParseTranslationGroupsByCLID	11-13
ParseTranslationGroupsByDNIS	11-13
ParseTranslationGroupsByRealm	11-13
UseCLIDAsSessionKey	11-13
USRIncomingScript	11-13
USRIncomingScript-IgnoreAccountingSignature	11-14
USROutgoingScript	11-14

CHAPTER 12**Using Replication 12-1**

Replication Overview	12-1
How Replication Works	12-2
Replication Data Flow	12-3
Master Server	12-3
Slave Server	12-3
Security	12-4
Replication Archive	12-4
Ensuring Data Integrity	12-4
Transaction Data Verification	12-4
Transaction Order	12-5
Automatic Resynchronization	12-5
Full Resynchronization	12-5
Understanding Hot-Configuration	12-6
Replication's Impact on Request Processing	12-6
Replication Configuration Settings	12-6
RepType	12-7
RepTransactionSyncInterval	12-7
Master	12-7
Slave	12-7
RepTransactionArchiveLimit	12-8
RepIPAddress	12-8
RepPort	12-8
RepSecret	12-8
ReplsMaster	12-9
RepMasterIPAddress	12-9
RepMasterPort	12-9
Rep Members Subdirectory	12-9
Rep Members/Slave1	12-9
Name	12-9
IPAddress	12-9
Port	12-10
Setting Up Replication	12-10
Configuring The Master	12-10
Configuring The Member	12-11
Verifying the Configuration	12-12
Replication Example	12-13
Adding a User	12-13
Master Server's Log	12-13

- Member Server's Log 12-13
- Verifying Replication 12-14
 - Master Server's Log 12-14
 - Member Server's Log 12-14
- Using aregcmd -pf Option 12-14
 - Master Server's Log 12-15
 - Member Server's Log 12-15
- An Automatic Resynchronization Example 12-16
 - Master Server's Log 12-16
 - Member Server's Log 12-17
- Full Resynchronization 12-17
- Replication Setup with More Than One Slave 12-19
- Frequently Asked Questions 12-19
- Replication Log Messages 12-21
 - Information Log Messages 12-21
 - Warning Log Messages 12-22
 - Error Log Messages 12-23
 - Log Messages You Should Never See 12-25

CHAPTER 13

Using On-Demand Address Pools 13-1

- Cisco-Incoming Script 13-3
 - How the Script Works 13-3
 - CiscoWithODAPIncomingScript 13-3
- Vendor Type CiscoWithODAP 13-4
- Configuring Cisco Prime Access Registrar to Work with ODAP 13-5
 - Configuring Cisco Prime AR to work with ODAP 13-5
 - Configuring the ODAP Detailed Instructions 13-5
 - Setting Up an ODAP UserList 13-5
 - Adding ODAP Users 13-6
 - Setting Up an ODAP-Users Service 13-7
 - Setting Up an ODAP Accounting Service 13-8
 - Adding Session Managers 13-8
 - Setting Up Resource Managers 13-9
 - Configuring Session Managers 13-14
 - Configure Clients 13-15
 - Save Your Configuration 13-16

CHAPTER 14

Using Identity Caching 14-1

- Overview 14-1

Identity Caching Features	14-2
Configuring Cisco Prime Access Registrar for Identity Caching	14-3
Starting Identity Caching	14-6
XML Interface	14-8

CHAPTER 15**Using Trusted ID Authorization with SESM 15-1**

Trusted ID Operational Overview	15-1
Configuration Overview	15-2
Request Processing	15-2
Session Cache Life Cycle	15-3
Configuration Restrictions	15-3
Software Requirements	15-3
Installing Cisco Prime Access Registrar	15-4
Running the TrustedIdInstall Program	15-4
Using the TrustedIdInstall.bin GUI	15-4
Using the TrustedIdInstall Command Line	15-8
Configuring Cisco Prime Access Registrar for Trusted Identity with SESM	15-12
Configuring the RADIUS Ports	15-12
Configuring NAS Clients	15-13
Configuring AAA and SPE Services	15-13
Configuration Imported by TrustedIdInstall Program	15-14
/Radius	15-14
/radius/services/spe	15-14
/radius/services/trusted-id	15-14
/Radius/SessionManagers/session-cache/	15-14
/radius/ResourceManagers/session-cache	15-14
/radius/advanced/	15-15
/Radius/Scripts/ChangeServiceType	15-15
Configuring EAP-MD5 Authentication	15-15
Creating the CheckEap.tcl Script	15-15
Adding the CheckEap.tcl Script	15-16
Using the CheckEap.tcl Script	15-16
Adding the EAP-MD5 Authentication Service	15-17
Adding an LDAP Remote Server	15-17
Adding an LDAP Service	15-18
Saving the Configuration and Reloading the Server	15-19
Cisco SSG VSAs in Cisco Prime Access Registrar Dictionary	15-20

CHAPTER 16

Using Prepaid Billing 16-1

- Overview 16-2
- IS835C Prepaid Billing 16-2
 - Configuring IS835C Prepaid Billing 16-3
 - Setting Up a Prepaid Billing RemoteServer 16-3
 - Setting Up an IS835C Prepaid Service 16-4
 - Setting Up Local Authentication 16-5
 - Setting Up an Authentication Group Service 16-5
- CRB Prepaid Billing 16-7
 - Configuring CRB Prepaid Billing 16-8
 - Setting Up a Prepaid Billing RemoteServer 16-8
 - Setting Up a CRB Prepaid Service 16-9
 - Setting Up a Local Accounting Service 16-10
 - Setting Up a Local Authentication Service 16-12
 - Setting Up a Prepaid Accounting Group Service 16-12
 - Setting Up an Authentication Group Service 16-14
 - Configuring CRB Prepaid Billing for SSG 16-15
 - Generic Call Flow 16-18
 - Access-Request (Authentication) 16-19
 - Access-Accept (Authentication) 16-20
 - Access-Request (Authorization) 16-20
 - Access-Accept (Authorization) 16-21
 - Accounting-Start 16-22
 - Data Flow 16-22
 - Access-Request (Quota Depleted) 16-22
 - Accept-Accept (Quota Depleted) 16-23
 - Accounting Stop (Session End) 16-23
 - Accounting Response (Final Status) 16-23
 - Vendor-Specific Attributes 16-25
- Implementing the Prepaid Billing API 16-27

CHAPTER 17

Using Cisco Prime Access Registrar Server Features 17-1

- Incoming Traffic Throttling 17-2
 - MaximumIncomingRequestRate 17-2
 - MaximumOutstandingRequests 17-2
- Backing Store Parsing Tool 17-3
- Configurable Worker Threads Enhancement 17-4
- Session-Key Lookup 17-5

Query-Notify	17-6
Call Flow	17-7
Configuration Examples	17-8
Memory and Performance Impact	17-9
Support for Windows Provisioning Service	17-9
Call Flow	17-10
Example Configuration	17-10
Environment Variables	17-11
Master URL Fragments	17-11
Unsupported Features	17-12
Account Expiration and Renewal	17-12
Password Changing and Force Update	17-13
Command Completion	17-13
Service Grouping Feature	17-14
Configuration Example - AccountingGroupService	17-14
Summary of Events	17-17
Configuration Example 2 - AuthenticationGroupService	17-17
Summary of Events	17-20
SHA-1 Support for LDAP-Based Authentication	17-21
Remote LDAP Server Password Encryption	17-21
Dynamic Password Encryption	17-22
Logs	17-23
Dynamic Attributes	17-23
Object Properties with Dynamic Support	17-23
Dynamic Attribute Format	17-25
Tunneling Support Feature	17-25
Configuration	17-26
Example	17-26
Notes	17-26
Validation	17-26
xDSL VPI/VCI Support for Cisco 6400	17-27
Using User-Name/User-Password for Each Cisco 6400 Device	17-27
Format of the New User-Name Attribute	17-27
Apply Profile in Cisco Prime Access Registrar Database to Directory Users	17-28
User-Profile	17-28
User-Group	17-29
Example User-Profile and User-Group Attributes in Directory User Record	17-29
Directory Multi-Value Attributes Support	17-29
MultiLink-PPP (ML-PPP)	17-30

- Dynamic Updates Feature 17-31
- NAS Monitor 17-32
- Automatic Information Collection (arbug) 17-32
 - Running arbug 17-33
 - Files Generated 17-33
- Simultaneous Terminals for Remote Demonstration 17-34
- Support for RADIUS Check Item Attributes 17-34
 - Configuring Check Items 17-34
- User-Specific Attributes 17-35
- Packet of Disconnect 17-36
 - Configuring Packet of Disconnect 17-36
 - Configuring the Client Object 17-36
 - Configuring a Resource Manager for POD 17-37
 - Proxying POD Requests from External Servers 17-38
 - CLI Options for POD 17-38
 - query-sessions 17-38
 - release-sessions 17-39
- Configuring Change of Authorization Requests 17-39
 - Configuring the Client Object 17-40
- Dynamic DNS 17-41
 - Configuring Dynamic DNS 17-42
 - Testing Dynamic DNS with radclient 17-43
- Dynamic Service Authorization Feature 17-44
 - Configuring Dynamic Service Authorization Feature 17-44
 - Setting up the Environment Variable 17-45
- Remote Session Management 17-47
- Wx Interface Support for SubscriberDB Lookup 17-48
 - Configuration Examples 17-48
- Smart Grid Solution Management 17-50
- TACACS+ Support for AA 17-50
 - Configuration Example 17-51

CHAPTER 18

- Directing RADIUS Requests 18-1**
 - Configuring Policies and Rules 18-1
 - Configuring Policies 18-1
 - Configuring Rules 18-2
 - Wildcard Support 18-2
 - Script and Attribute Requirements 18-3

Validation	18-4
Known Anomalies	18-4
Routing Requests	18-4
Routing Requests Based on Realm	18-4
Routing Requests Based on DNIS	18-5
Routing Requests Based on CLID	18-6
Routing Requests Based on NASIP	18-7
Routing Requests Based on User-Name Prefix	18-8
Attribute Translation	18-9
Translations	18-9
TranslationGroups	18-9
Parsing Translation Groups	18-10
Time of Day Access Restrictions	18-11
Setting Time Ranges in ExecTimeRule	18-12
ExecTimeRule Example Configuration	18-12
Reducing Overhead Using Policies to Group Rules	18-13
Standard Scripts Used with Rules	18-15
ExecRealmRule	18-15
ExecDNISRule	18-16
ExecCLIDRule	18-16
ExecNASIPRule	18-17
ExecPrefixRule	18-17
ExecSuffixRule	18-18
Configuring Suffix and Prefix Policies	18-19
ExecTimeRule	18-20
ParseTranslationGroupsByRealm	18-20
ParseTranslationGroupsByDNIS	18-20
ParseTranslationGroupsByCLID	18-21
ParseTranslationGroupsByDNIS	18-21

CHAPTER 19**Wireless Support 19-1**

Mobile Node-Home Agent Shared Key	19-1
Use Case Example	19-1
Configuring User Attributes	19-2
3GPP2 Home Agent Support	19-3
Home-Agent Resource Manager	19-3
Load Balancing	19-3
Querying and Releasing Sessions	19-4
Access Request Requirements	19-5

New 3GPP2 VSAs in the Cisco Prime Access Registrar Dictionary 19-5

Session Correlation Based on User-Defined Attributes 19-5

Managing Multiple Accounting Start/Stop Messages 19-6

NULL Password Support 19-6

CHAPTER 20

Using LDAP 20-1

Configuring LDAP 20-1

 Configuring the LDAP Service 20-2

 MultipleServersPolicy 20-2

 RemoteServers 20-3

 Configuring an LDAP RemoteServer 20-3

 DNS Look Up and LDAP Rebind Interval 20-6

 LDAPToRadiusMappings 20-7

 LDAPToEnvironmentMappings 20-7

 LDAPToCheckItemMappings 20-7

 Setting LDAP As Authentication and Authorization Service 20-7

 Saving Your Configuration 20-7

 CHAP Interoperability with LDAP 20-8

 Allowing Special Characters in LDAP Usernames 20-8

 Dynamic LDAP Search Base 20-8

Analyzing LDAP Trace Logs 20-9

 Successful Bind Message 20-9

 Bind Failure Messages 20-9

 Login Failure Messages 20-10

Bind-Based Authentication for LDAP 20-11

CHAPTER 21

Using Open Database Connectivity 21-1

Oracle Software Requirements 21-2

Configuring ODBC/OCI 21-2

 Configuring an ODBC/OCI Service 21-6

 Configuring an ODBC/OCI RemoteServer 21-7

 ODBC Data Source 21-9

 SQL Definitions 21-9

 SQL Syntax Restrictions 21-10

 Specifying More Than One Search Key 21-10

 ODBCToRadiusMappings/OCIToRadiusMappings 21-11

 ODBCToEnvironmentMappings/OCIToEnvironmentMappings 21-11

ODBCToCheckItemMappings/OCIToCheckItemMappings 21-11

 Configuring an ODBC DataSource 21-11

Setting ODBC/OCI As Authentication and Authorization Service	21-12
Setting ODBC/OCI As Accounting Service	21-13
Saving Your Configuration	21-13
Oracle Stored Procedures	21-13
MySQL Support	21-15
MySQL Driver	21-15
Configuring a MySQL Datasource	21-15
Example Configuration	21-17

CHAPTER 22**SIGTRAN-M3UA 22-1**

Prerequisites to SIGTRAN-M3UA	22-2
Configuring EAP-AKA/EAP-SIM with SIGTRAN-M3UA	22-3
Configuring M3UA Service	22-10

CHAPTER 23**Using SNMP 23-1**

Overview	23-1
Supported MIBs	23-1
RADIUS-AUTH-CLIENT-MIB	23-2
RADIUS-AUTH-SERVER-MIB	23-2
RADIUS-ACC-CLIENT-MIB	23-2
RADIUS-ACC-SERVER-MIB	23-2
CISCO-DIAMETER-BASE-PROTOCOL-MIB	23-2
Diameter SNMP and Statistics Support	23-2
TACACS+ SNMP and Statistics Support	23-3
SNMP Traps	23-3
Supported Traps	23-3
carServerStart	23-4
carServerStop	23-4
carInputQueueFull	23-4
carInputQueueNotVeryFull	23-5
carOtherAuthServerNotResponding	23-5
carOtherAuthServerResponding	23-5
carOtherAccServerNotResponding	23-5
carOtherAccServerResponding	23-6
carAccountingLoggingFailure	23-6
carLicenseUsage	23-6
carDiameterPeerDown	23-7
carDiameterPeerUp	23-7
Configuring Traps	23-7

Directories Searched	23-7
Configuration File Types	23-8
Switching Configuration Files in Mid-File	23-8
Configuring Trap Recipient	23-9
Community String	23-9

CHAPTER 24

Enforcement of Licensing Models 24-1

TPS Licensing Features	24-1
Enforcement Rules	24-1
Notification Logs	24-2
Notification - SNMP Traps	24-2
TPS Logging Feature	24-3
Concurrent Session License Features	24-3
Sessions Enforcement Rules	24-4
Notification Logs	24-4
Notification - SNMP Traps	24-5
Session Logging Feature	24-5

CHAPTER 25

Backing Up the Database 25-1

Configuration	25-1
Command Line Utility	25-1
Recovery	25-2
mcdshadow Command Files	25-2

CHAPTER 26

Using the REX Accounting Script 26-1

Building and Installing the REX Accounting Script	26-1
Configuring the Rex Accounting Script	26-2
Specifying REX Accounting Script Options	26-4
Example Script Object	26-5

CHAPTER 27

Logging Syslog Messages 27-1

Syslog Messages	27-1
Example 1	27-2
Example 2	27-2
Configuring Message Logging (Solaris)	27-3
Configuring Message Logging (Linux)	27-4
Changing Log Directory	27-4
Configuring Syslog Daemon (syslogd)	27-5

Managing the Syslog File	27-5
Using a cron Program to Manage the Syslog Files	27-6
Server Up/Down Status Change Logging	27-6
Header Formats	27-6
Example Log Messages	27-7

CHAPTER 28**Troubleshooting Cisco Prime Access Registrar 28-1**

Gathering Basic Information	28-1
Troubleshooting Quick Checks	28-2
Disk Space	28-2
Resource Conflicts	28-2
No Co-Existence With Cisco Network Registrar	28-2
Port Conflicts	28-3
Server Running Sun SNMP Agent	28-3
Cisco Prime Access Registrar Log Files	28-3
Modifying File Sizes for Agent Server and MCD Server Logs	28-3
Using xtail to Monitor Log File Activity	28-4
Modifying the Trace Level	28-4
Installation and Server Process Start-up	28-5
aregcmd and Cisco Prime Access Registrar Configuration	28-5
Running and Stopped States	28-5
RADIUS Request Processing	28-7
Other Troubleshooting Techniques and Resources	28-7
aregcmd Stats Command	28-7
Core Files	28-8
radclient	28-8
Cisco Prime Access Registrar Replication	28-8
Checking AR Server Health Status	28-8

APPENDIX A**Cisco Prime Access Registrar Tcl, REX and Java Dictionaries A-1**

Tcl Attribute Dictionaries	A-1
Attribute Dictionary Methods	A-1
Tcl Environment Dictionary	A-4
REX Attribute Dictionary	A-5
Attribute Dictionary Methods	A-5
REX Environment Dictionary	A-11
REX Environment Dictionary Methods	A-11
Java Attribute Dictionary	A-13

- Java Attribute Dictionary Methods **A-13**
- Java Environment Dictionary **A-16**
 - Java Environment Dictionary Methods **A-16**
- Interface Extension **A-17**
 - Interface Extension Methods **A-18**
- Interface ExtensionforSession **A-18**
 - Interface Extensionforsession Methods **A-19**
- Interface Extensionwithinitialization **A-19**
 - Interface Extensionwithinitialization Methods **A-20**
- Interface ExtensionforSessionwithinitialization **A-20**
 - Interface Extensionforsessionwithinitialization Methods **A-20**
- Interface MarkerExtension **A-20**
 - Variables in the Marker Extension Interface **A-21**
- Class Sessionrecord **A-24**
 - Session Record Methods **A-24**

APPENDIX B

Environment Dictionary B-1

- Cisco Prime Access Registrar Environment Dictionary Variables **B-1**
 - Accepted-Profiles **B-1**
 - Accounting-Service **B-2**
 - Acquire-Dynamic-DNS **B-2**
 - Acquire-Group-Session-Limit **B-2**
 - Acquire-Home-Agent **B-2**
 - Acquire-IP-Dynamic **B-2**
 - Acquire-IPX-Dynamic **B-2**
 - Acquire-IP-Per-NAS-Port **B-2**
 - Acquire-Subnet-Dynamic **B-3**
 - Acquire-User-Session-Limit **B-3**
 - Acquire-USR-VPN **B-3**
 - Allow-Null-Password **B-3**
 - Authentication-Service **B-3**
 - Authorization-Service **B-3**
 - AuthorizationInfo **B-3**
 - BackingStore-Env-Vars **B-4**
 - Broadcast-Accounting-Packet **B-4**
 - Cache-Attributes-In-Session **B-4**
 - Current-Group-Count **B-4**
 - Cache-Outer-Identity **B-4**
 - Destination-IP-Address **B-4**
 - Destination-Port **B-4**

Dest-Translation-Type	B-5
Dest-Numbering-Plan	B-5
Dest-Encoding-Scheme	B-5
Dest-Nature-Of-Address	B-6
Dest-GT-Format	B-6
Disable-Accounting-On-Off-Broadcast	B-6
DSA-Response-Cache	B-7
Dynamic-DNS-HostName	B-7
Dynamic-Search-Filter	B-7
Dynamic-Search-Path	B-7
Dynamic-Search-Scope	B-7
Dynamic-Service-Loop-Limit	B-7
Dynamic-User-Password-Attribute	B-7
EAP-Actual-Identity	B-7
EAP-Authentication-Mode	B-8
Enforce-Traffic-Throttling	B-8
Generate-BEK	B-8
Group-Session-Limit	B-8
HLR-GlobalTitle-Address	B-8
HLR-Translated-IMSI	B-8
Ignore-Accounting-Signature	B-8
Incoming-Translation-Groups	B-9
Master-URL-Fragment	B-9
Misc-Log-Message-Info	B-9
Outgoing-Translation-Groups	B-9
Pager	B-9
Query-Service	B-9
Re-Accounting-Service	B-9
Re-Authentication-Service	B-10
Re-Authorization-Service	B-10
Realm	B-10
Reject-Reason	B-10
Remote-Server	B-10
Remove-Session-On-Acct-Stop	B-10
Remote-Servers-Tried	B-10
Request-Authenticator	B-11
Request-Type	B-11
Require-User-To-Be-In-Authorization-List	B-12
Response-Type	B-12
Retrace-Packet	B-12

- Send-PEAP-URI-TLV **B-12**
- Session-Key **B-12**
- Session-Manager **B-12**
- Session-Notes **B-13**
- Session-Service **B-13**
- Set-Session-Mgr-And-Key-Upon-Lookup **B-13**
- Skip-Session-Management **B-13**
- Skip-Overriding-Username-With-LDAP-UID **B-13**
- Skip-Overriding-UserName-With-PEAPIdentity **B-13**
- Source-IP-Address **B-13**
- Source-Port **B-15**
- Subnet-Size-If-No-Match **B-15**
- Trace-Level **B-15**
- Unavailable-Resource **B-15**
- Unavailable-Resource-Type **B-15**
- UserDefined1 **B-15**
- User-Authorization-Script **B-15**
- User-Group **B-16**
- User-Group-Session-Limit **B-16**
- User-Name **B-16**
- User-Profile **B-16**
- User-Session-Limit **B-16**
- Virtual-Server-Outgoing-Script **B-16**
- Windows-Domain-Groups **B-16**
- X509- Subject-Name **B-16**
- Internal Variables **B-17**

APPENDIX C

RADIUS Attributes C-1

- RADIUS Attributes **C-1**
 - Cisco Prime Access Registrar Attributes **C-1**
 - RADIUS Attributes Numeric List **C-4**
- Vendor-Specific Attributes **C-13**
 - 3GPP VSAs **C-13**
 - 3GPP2 VSAs **C-15**
 - ACC VSAs **C-22**
 - Altiga VSAs **C-27**
 - Ascend VSAs **C-30**
 - Bay Networks VSAs **C-45**
 - Cabletron VSAs **C-46**

Cisco Prime Access Registrar Internal VSAs	C-46
Cisco VSAs	C-48
Compatible VSAs	C-51
Microsoft VSAs	C-51
Nomadix VSAs	C-53
RedBack VSAs	C-53
RedCreek VSAs	C-56
TACACS+ VSAs	C-56
Telebit VSAs	C-59
Unisphere VSAs	C-59
USR VSAs	C-60
WiMax	C-86
WISPr	C-86
XML	C-87

GLOSSARY

INDEX



About This Guide

The *User Guide for Cisco Prime Access Registrar, 6.0* provides information about how to use Cisco Prime Access Registrar (Cisco Prime AR) 6.0. This preface contains the following sections:

- [How This Book Is Organized, page xxxiii](#)
- [Obtaining Documentation and Submitting a Service Request, page xxxv](#)
- [Related Documentation, page xxxv](#)
- [Notices, page xxxv](#)

How This Book Is Organized

The Cisco Prime AR User Guide is organized as follows:

[Chapter 1, “Overview,”](#) provides an overview of Cisco Prime AR.

[Chapter 2, “Using the aregcmd Commands,”](#) provides information about using **aregcmd** commands.

[Chapter 3, “Using the Graphical User Interface,”](#) provides information about using the Cisco Prime AR GUI.

[Chapter 4, “Cisco Prime Access Registrar Server Objects,”](#) provides information about Cisco Prime AR server objects.

[Chapter 5, “Using the radclient Command,”](#) provides information about using **radclient** commands to test Cisco Prime AR.

[Chapter 6, “Configuring Local Authentication and Authorization,”](#) provides information about how to configure local authentication and authorization and helpful examples.

[Chapter 7, “RADIUS Accounting,”](#) provides information about RADIUS accounting and how to configure Cisco Prime AR to perform accounting.

[Chapter 20, “Using LDAP,”](#) provides information about using an LDAP remote server with Cisco Prime AR.

[Chapter 8, “Diameter”](#) provides information about how to configure Cisco Prime AR to perform diameter authentication and authorization, and also provides information about Diameter Accounting.

[Chapter 9, “Extensible Authentication Protocols,”](#) provides information about Cisco Prime AR support of EAP authentication methods.

[Chapter 10, “Using WiMAX in Cisco Prime Access Registrar,”](#) provides information about Cisco Prime AR support for the WiMAX feature.

[Chapter 11, “Using Extension Points,”](#) provides information about how to use Cisco Prime AR scripting to customize your RADIUS server.

[Chapter 12, “Using Replication,”](#) provides information about how to use the replication feature.

[Chapter 13, “Using On-Demand Address Pools,”](#) provides information about using On-Demand Address Pools.

[Chapter 14, “Using Identity Caching,”](#) provides information about using the Identity Caching feature.

[Chapter 15, “Using Trusted ID Authorization with SESM,”](#) describes how to use Cisco Prime AR with SESM, and how to configure Cisco Prime AR to use the Trusted ID feature.

[Chapter 16, “Using Prepaid Billing,”](#) provides information about how to use the Cisco Prime AR prepaid billing feature.

[Chapter 17, “Using Cisco Prime Access Registrar Server Features,”](#) provides information about using Cisco Prime AR features.

[Chapter 18, “Directing RADIUS Requests,”](#) provides information about using the Cisco Prime AR Policy Engine.

[Chapter 19, “Wireless Support,”](#) provides information about Cisco Prime AR support for wireless features.

[Chapter 21, “Using Open Database Connectivity,”](#) provides information about a new type of RemoteServer object and a new service to support ODBC.

[Chapter 22, “SIGTRAN-M3UA,”](#) provides information about SIGTRAN-M3UA remote server and a service to support EAP-AKA/EAP-SIM authentication.

[Chapter 23, “Using SNMP,”](#) provides information about the SNMP MIB and Trap support offered by Cisco Prime AR.

[Chapter 24, “Enforcement of Licensing Models,”](#) provides information on the enforcement of Cisco Prime AR’s new license model—transactions per second(TPS) Licensing.

[Chapter 25, “Backing Up the Database,”](#) describes the Cisco Prime AR shadow backup facility, which ensures a consistent snapshot of Cisco Prime AR’s database for backup purposes.

[Chapter 26, “Using the REX Accounting Script,”](#) describes how to use the REX Accounting scripts.

[Chapter 27, “Logging Syslog Messages,”](#) provides information about logging messages via syslog and centralized error reporting for Cisco Prime AR.

[Chapter 28, “Troubleshooting Cisco Prime Access Registrar,”](#) provides information about techniques used when troubleshooting Cisco Prime AR and highlights common problems.

[Appendix A, “Cisco Prime Access Registrar Tcl, REX and Java Dictionaries,”](#) describes the Tcl and REX dictionaries that are used when writing Incoming or Outgoing scripts for use with Cisco Prime AR.

[Appendix B, “Environment Dictionary,”](#) describes the environment variables the scripts use to communicate with Cisco Prime AR or to communicate with other scripts.

[Appendix C, “RADIUS Attributes,”](#) lists the RFC 2865 RADIUS attributes with their names and values. An index is also provided.

Obtaining Documentation and Submitting a Service Request

For information on obtaining documentation, submitting a service request, and gathering additional information, see the monthly *What's New in Cisco Product Documentation*, which also lists all new and revised Cisco technical documentation, at:

<http://www.cisco.com/en/US/docs/general/whatsnew/whatsnew.html>

Subscribe to the *What's New in Cisco Product Documentation* as a Really Simple Syndication (RSS) feed and set content to be delivered directly to your desktop using a reader application. The RSS feeds are a free service and Cisco currently supports RSS Version 2.0.

Related Documentation

The following is a list of documentation for Cisco Prime AR 6.0. You can access the URLs listed for each document at www.cisco.com on the World Wide Web. We recommend that you refer to the documents in the following order:

Cisco Prime Access Registrar 6.0 Documentation Guide (OL-26927)

http://www.cisco.com/en/US/docs/net_mgmt/prime/access_registrar/6.0/roadmap/guide/PrintPDF/ardocgd.html

Notices

The following notices pertain to this software license.

OpenSSL/Open SSL Project

This product includes software developed by the OpenSSL Project for use in the OpenSSL Toolkit (<http://www.openssl.org/>).

This product includes cryptographic software written by Eric Young (eay@cryptsoft.com).

This product includes software written by Tim Hudson (tjh@cryptsoft.com).

License Issues

The OpenSSL toolkit stays under a dual license, i.e. both the conditions of the OpenSSL License and the original SSLeay license apply to the toolkit. See below for the actual license texts. Actually both licenses are BSD-style Open Source licenses. In case of any license issues related to OpenSSL please contact openssl-core@openssl.org.

OpenSSL License:

Copyright © 1998-2007 The OpenSSL Project. All rights reserved.

Redistribution and use in source and binary forms, with or without modification, are permitted provided that the following conditions are met:

1. Redistributions of source code must retain the copyright notice, this list of conditions and the following disclaimer.
2. Redistributions in binary form must reproduce the above copyright notice, this list of conditions, and the following disclaimer in the documentation and/or other materials provided with the distribution.
3. All advertising materials mentioning features or use of this software must display the following acknowledgment: “This product includes software developed by the OpenSSL Project for use in the OpenSSL Toolkit (<http://www.openssl.org/>)”.
4. The names “OpenSSL Toolkit” and “OpenSSL Project” must not be used to endorse or promote products derived from this software without prior written permission. For written permission, please contact openssl-core@openssl.org.
5. Products derived from this software may not be called “OpenSSL” nor may “OpenSSL” appear in their names without prior written permission of the OpenSSL Project.
6. Redistributions of any form whatsoever must retain the following acknowledgment:
 “This product includes software developed by the OpenSSL Project for use in the OpenSSL Toolkit (<http://www.openssl.org/>)”.

THIS SOFTWARE IS PROVIDED BY THE OpenSSL PROJECT “AS IS” AND ANY EXPRESSED OR IMPLIED WARRANTIES, INCLUDING, BUT NOT LIMITED TO, THE IMPLIED WARRANTIES OF MERCHANTABILITY AND FITNESS FOR A PARTICULAR PURPOSE ARE DISCLAIMED. IN NO EVENT SHALL THE OpenSSL PROJECT OR ITS CONTRIBUTORS BE LIABLE FOR ANY DIRECT, INDIRECT, INCIDENTAL, SPECIAL, EXEMPLARY, OR CONSEQUENTIAL DAMAGES (INCLUDING, BUT NOT LIMITED TO, PROCUREMENT OF SUBSTITUTE GOODS OR SERVICES; LOSS OF USE, DATA, OR PROFITS; OR BUSINESS INTERRUPTION) HOWEVER CAUSED AND ON ANY THEORY OF LIABILITY, WHETHER IN CONTRACT, STRICT LIABILITY, OR TORT (INCLUDING NEGLIGENCE OR OTHERWISE) ARISING IN ANY WAY OUT OF THE USE OF THIS SOFTWARE, EVEN IF ADVISED OF THE POSSIBILITY OF SUCH DAMAGE.

This product includes cryptographic software written by Eric Young (ey@cryptsoft.com). This product includes software written by Tim Hudson (tjh@cryptsoft.com).

Original SSLeay License:

Copyright © 1995-1998 Eric Young (ey@cryptsoft.com). All rights reserved.

This package is an SSL implementation written by Eric Young (ey@cryptsoft.com).

The implementation was written so as to conform with Netscapes SSL.

This library is free for commercial and non-commercial use as long as the following conditions are adhered to. The following conditions apply to all code found in this distribution, be it the RC4, RSA, lhash, DES, etc., code; not just the SSL code. The SSL documentation included with this distribution is covered by the same copyright terms except that the holder is Tim Hudson (tjh@cryptsoft.com).

Copyright remains Eric Young’s, and as such any Copyright notices in the code are not to be removed. If this package is used in a product, Eric Young should be given attribution as the author of the parts of the library used. This can be in the form of a textual message at program startup or in documentation (online or textual) provided with the package.

Redistribution and use in source and binary forms, with or without modification, are permitted provided that the following conditions are met:

1. Redistributions of source code must retain the copyright notice, this list of conditions and the following disclaimer.
2. Redistributions in binary form must reproduce the above copyright notice, this list of conditions and the following disclaimer in the documentation and/or other materials provided with the distribution.
3. All advertising materials mentioning features or use of this software must display the following acknowledgement:

“This product includes cryptographic software written by Eric Young (eay@cryptsoft.com)”.

The word ‘cryptographic’ can be left out if the routines from the library being used are not cryptography-related.

4. If you include any Windows specific code (or a derivative thereof) from the apps directory (application code) you must include an acknowledgement: “This product includes software written by Tim Hudson (tjh@cryptsoft.com)”.

THIS SOFTWARE IS PROVIDED BY ERIC YOUNG “AS IS” AND ANY EXPRESS OR IMPLIED WARRANTIES, INCLUDING, BUT NOT LIMITED TO, THE IMPLIED WARRANTIES OF MERCHANTABILITY AND FITNESS FOR A PARTICULAR PURPOSE ARE DISCLAIMED. IN NO EVENT SHALL THE AUTHOR OR CONTRIBUTORS BE LIABLE FOR ANY DIRECT, INDIRECT, INCIDENTAL, SPECIAL, EXEMPLARY, OR CONSEQUENTIAL DAMAGES (INCLUDING, BUT NOT LIMITED TO, PROCUREMENT OF SUBSTITUTE GOODS OR SERVICES; LOSS OF USE, DATA, OR PROFITS; OR BUSINESS INTERRUPTION) HOWEVER CAUSED AND ON ANY THEORY OF LIABILITY, WHETHER IN CONTRACT, STRICT LIABILITY, OR TORT (INCLUDING NEGLIGENCE OR OTHERWISE) ARISING IN ANY WAY OUT OF THE USE OF THIS SOFTWARE, EVEN IF ADVISED OF THE POSSIBILITY OF SUCH DAMAGE.

The license and distribution terms for any publicly available version or derivative of this code cannot be changed. i.e. this code cannot simply be copied and put under another distribution license [including the GNU Public License].



CHAPTER 1

Overview

The chapter provides an overview of the RADIUS server, including connection steps, RADIUS message types, and using Cisco Prime Access Registrar (Cisco Prime AR) as a proxy server.

Cisco Prime AR is a RADIUS (Remote Authentication Dial-In User Service) server that enables multiple dial-in Network Access Server (NAS) devices to share a common authentication, authorization, and accounting database.

Cisco Prime AR handles the following tasks:

- Authentication—determines the identity of users and whether they can be allowed to access the network
- Authorization—determines the level of network services available to authenticated users after they are connected
- Accounting—keeps track of each user's network activity
- Session and resource management—tracks user sessions and allocates dynamic resources

Using a RADIUS server allows you to better manage the access to your network, as it allows you to store all security information in a single, centralized database instead of distributing the information around the network in many different devices. You can make changes to that single database instead of making changes to every network access server in your network.

Cisco Prime AR also allows you to manage the complex interconnections of the new network elements in order to:

- adequately manage the traffic
- perform appropriate load balancing for desired load distribution
- allow binding of different protocol interfaces corresponding to a subscriber/network element

Service providers transform their 3G and 4G wireless networks with complex services, tiered charging, converged billing, and more by introducing increasing numbers and types of Diameter-based network elements. LTE and IMS networks are the most likely to implement these new network elements—including Policy and Charging Rules Functions (PCRF), Home Subscriber Servers (HSS), Mobility Management Entities (MME), Online Charging Systems (OCS), and others. As a result, as the traffic levels grow, these wireless networks are becoming more difficult to manage and scale without the Cisco Prime AR infrastructure.

This chapter contains the following sections:

- [Cisco Prime Access Registrar Hierarchy](#)
- [Cisco Prime Access Registrar Directory Structure](#)
- [Program Flow](#)
- [RADIUS Protocol](#)
- [Service and Ports Used in Cisco Prime AR](#)

Cisco Prime Access Registrar Hierarchy

Cisco Prime AR's operation and configuration is based on a set of *objects*. These objects are arranged in a hierarchical structure much like the Windows 95 Registry or the UNIX directory structure. Cisco Prime AR's objects can themselves contain subobjects, just as directories can contain subdirectories. These objects include the following:

- Radius—the root of the configuration hierarchy
- UserLists—contains individual UserLists which in turn contain users
- UserGroups—contains individual UserGroups
- Clients—contains individual Clients
- Vendors—contains individual Vendors
- Scripts—contains individual Scripts
- Services—contains individual Services
- SessionManagers—contains individual Session Managers
- ResourceManagers—contains individual Resource Managers
- Profiles—contains individual Profiles
- RemoteServers—contains individual RemoteServers
- Advanced—contains Ports, Interfaces, Reply Messages, and the Attribute dictionary

This section contains the following topics:

- [UserLists and Groups](#)
- [Profiles](#)
- [Scripts](#)
- [Services](#)
- [Session Management Using Resource Managers](#)

UserLists and Groups

Cisco Prime AR lets you organize your user community through the configuration objects **UserLists**, **users**, and **UserGroups**.

- Use **UserLists** to group users by organization, such as Company A and Company B. Each list contains the actual names of the users.
- Use **Users** to store information about particular users, such as name, password, group membership, base profile, and so on.

- Use **UserGroups** to group users by function, such as PPP, Telnet, or multiprotocol users. Groups allow you to maintain common authentication and authorization requirements in one place, and have them referenced by many users.

For more information about **UserLists** and **UserGroups**, see [UserLists and Groups](#) in Chapter 4, “Cisco Prime Access Registrar Server Objects.”

Profiles

Cisco Prime AR uses **Profiles** that allow you to group RADIUS attributes to be included in an Access-Accept packet. These attributes include values that are appropriate for a particular user class, such as PPP or Telnet user. The user’s base profile defines the user’s attributes, which are then added to the response as part of the authorization process.

Although you can use Group or Profile objects in a similar manner, choosing whether to use one rather than the other depends on your site. If you require some choice in determining how to authorize or authenticate a user session, then creating specific profiles, and specifying a group that uses a script to choose among the profiles is more flexible. In such a situation, you might create a default group and then write a script that selects the appropriate profile based on the specific request. The benefit to this technique is each user can have a single entry, and use the appropriate profile depending on the way they log in.

For more information about **Profiles**, see [Profiles](#) in Chapter 4, “Cisco Prime Access Registrar Server Objects.”

Scripts

Cisco Prime AR allows you to create scripts you can execute at various points within the processing hierarchy.

- Incoming scripts—enable you to read and set the attributes of the request packet, and set or change the Environment dictionary variables. You can use the environment variables to control subsequent processing, such as specifying the use of a particular authentication service.
- Outgoing scripts—enable you to modify attributes returned in the response packet.

For more information about **Scripts**, see [Scripts](#) in the Chapter 4, “Cisco Prime Access Registrar Server Objects.”

Services

Cisco Prime AR uses *Services* to let you determine how authentication, authorization, and/or accounting are performed.

For example, to use Services for authentication:

- When you want the authentication to be performed by the Cisco Prime AR RADIUS server, you can specify the **local** service. In this case you must specify a specific **UserList**.
- When you want the authentication performed by another server, which might run an independent application on the same or different host than your RADIUS server, you can specify either a **radius**, **ldap**, or **tacacs-udp** service. In this case, you must list these servers by name.

When you have specified more than one authentication service, Cisco Prime AR determines which one to use for a particular Access-Request by checking the following:

- When an incoming script has set the Environment dictionary variable **Authentication-Service** with the name of a Service, Cisco Prime AR uses that service.
- Otherwise, Cisco Prime AR uses the default authentication service. The default authentication service is a property of the **Radius** object.

Cisco Prime AR chooses the authentication service based on the variable **Authentication-Service**, or the default. The properties of that Service, specify many of the details of that authentication service, such as, the specific user list to use or the specific application (possibly remote) to use in the authentication process.

For more information about Services, see [Services](#) in the [Chapter 4, “Cisco Prime Access Registrar Server Objects.”](#)

Session Management Using Resource Managers

Cisco Prime AR lets you track user sessions, and/or allocate dynamic resources to users for the lifetime of their session. You can define one or more Session Managers, and have each one manage the sessions for a particular group or company.

Session Managers use Resource Managers, which in turn manage resources of a particular type as described below.

- IP-Dynamic—manages a pool of IP addresses and allows you to dynamically allocate IP addresses from that pool
- IP-Per-NAS-Port—allows you to associate ports to specific IP addresses, and thus ensure each NAS port always gets the same IP address
- IPX-Dynamic—manages a pool of IPX network addresses
- Group-Session-Limit—manages concurrent sessions for a group of users; that is, it keeps track of how many sessions are active and denies new sessions after the configured limit has been reached
- User-Session-Limit—manages per-user concurrent sessions; that is, it keeps track of how many sessions each user has and denies the user a new session after the configured limit has been reached
- USR-VPN—manages Virtual Private Networks (VPNs) that use USR NAS Clients.

For more information about Session Managers, see [Session Managers](#) in [Chapter 4, “Cisco Prime Access Registrar Server Objects.”](#)

If necessary, you can create a complex relationship between the Session Managers and the Resource Managers.

When you need to share a resource among Session Managers, you can create multiple Session Managers that refer to the same Resource Manager. For example, if one pool of IP addresses is shared by two departments, but each department has a separate policy about how many users can be logged in concurrently, you might create two Session Managers and three Resource Managers. One dynamic IP Resource Manager that is referenced by both Session Managers, and two concurrent session Resource Managers, one for each Session Manager.

In addition, Cisco Prime AR lets you pose queries about sessions. For example, you can query Cisco Prime AR about which session (and thus which NAS-Identifier, NAS-Port and/or User-Name) owns a particular resource, as well as query Cisco Prime AR about how many resources are allocated or how many sessions are active.

Cisco Prime Access Registrar Directory Structure

The installation process populates the `/opt/CSCOar` directory with the subdirectories listed in [Table 1-1](#).

Table 1-1 */opt/CSCOar Subdirectories*

Subdirectory	Description
<code>.system</code>	Contains ELF's, or binary SPARC executables that should not be run directly.
<code>bin</code>	Contains shell scripts and programs frequently used by a network administrator; programs that can be run directly.
<code>conf</code>	Contains configuration files.
<code>data</code>	Contains the <code>radius</code> directory, which contains session backing files; and the <code>db</code> directory, which contains configuration database files .
<code>examples</code>	Contains documentation, sample configuration scripts, and shared library scripts.
<code>lib</code>	Contains Cisco Prime AR software library files.
<code>logs</code>	Contains system logs and is the default directory for RADIUS accounting.
<code>odbc</code>	Contains Cisco Prime AR ODBC files.
<code>scripts</code>	Contains sample scripts that you can modify to automate configuration, and to customize your RADIUS server.
<code>temp</code>	Used for temporary storage.
<code>ucd-snmp</code>	Contains the UCD-SNMP software Cisco Prime AR uses.
<code>usrbin</code>	Contains a symbolic link that points to <code>bin</code> .

Program Flow

When a NAS sends a request packet to Cisco Prime AR with a name and password, Cisco Prime AR performs the following actions. [Table 1-2](#) describes the flow without regard to scripting points.

Table 1-2 *From Access-Request to Access-Accept*

Cisco Prime AR Server Action	Explanation
Receives an Access-Request	The Cisco Prime AR server receives an Access-Request packet from a NAS.
Determines whether to accept the request	The Cisco Prime AR server checks to see if the client's IP address is listed in <code>/Radius/Clients/<Name>/<IPAddress></code> .
Invokes the policy SelectPolicy if it exists	The Cisco Prime AR Policy Engine provides an interface to define and configure a policy and to apply the policy to the corresponding access-request packets.
Performs authentication and/or authorization	Directs the request to the appropriate service, which then performs authentication and/or authorization according to the type specified in <code>/Radius/Services/<Name>/<Type></code> .
Performs session management	Directs the request to the appropriate Session Manager.

Table 1-2 From Access-Request to Access-Accept (continued)

Cisco Prime AR Server Action	Explanation
Performs resource management for each Resource Manager in the SessionManager	Directs the request to the appropriate resource manager listed in /Radius/SessionManagers/<Name>/<ResourceManagers>/<Name> , which then allocates or checks the resource according to the type listed in /Radius/<ResourceManagers>/<Name>/<Type> .
Sends an Access-Accept	Creates and formats the response, and sends it back to the client (NAS).

Scripting Points

Cisco Prime AR lets you invoke scripts you can use to affect the Request, Response, or Environment dictionaries. This section contains the following topics:

- [Client Scripting](#)
- [Client or NAS Scripting Points](#)
- [Authentication and/or Authorization Scripting Points](#)

Client Scripting

Though, Cisco Prime AR allows external code (Tcl/C/C++/Java) to be used by means of a script, custom service, policy engine, and so forth, while processing request, response, or while working with the environment dictionaries, it shall not be responsible for the scripts used and will not be liable for any direct, indirect, incidental, special, exemplary, or consequential damages (including, but not limited to, procurement of substitute goods or services; loss of use, data, or profits; or business interruption) however caused and on any theory of liability, whether in contract, strict liability, or tort (including negligence or otherwise) arising in any way out of the use of the script.

Client or NAS Scripting Points

[Table 1-3](#) shows the location of the scripting points within the section that determines whether to accept the request from the client or NAS. Note, the scripting points are indicated with the asterisk (*) symbol.

Table 1-3 Client or NAS Scripting Points

Action	Explanation
Receives an Access-Request.	The Cisco Prime AR RADIUS server receives an Access-Request packet from a NAS.
Determines whether to accept the request.	The client's IP address listed in /Radius/Clients/<Name>/IPAddress .
*Executes the server's incoming script.	A script referred to in /Radius/IncomingScript .
*Executes the vendor's incoming script.	The vendor listed in /Radius/Clients/Name/Vendor , and is a script referred to in /Radius/Vendors/<Name>/IncomingScript .
*Executes the client's incoming script.	A script referred to in /Radius/Clients/<Name>/IncomingScript .

Table 1-3 Client or NAS Scripting Points (continued)

Action	Explanation
Determines whether to accept requests from this specific NAS.	<p>/Radius/Advanced/RequireNASsBehindProxyBeInClientList set to TRUE.</p> <p>The NAS's Identifier listed in /Radius/Clients/<Name>, or its NAS-IP-Address listed in /Radius/Clients/<Name>/IPAddress.</p>
If the client's IP address listed in /Radius/Clients/<Name>/IPAddress is different:	
*Executes the vendor's incoming script.	The vendor listed in /Radius/Clients/Name/Vendor , and is a script referred to in /Radius/Vendors/<Name>/IncomingScript .
*Executes the client's incoming script.	The client listed in the previous /Radius/Clients/Name , and is a script referred to in /Radius/Clients/Name/IncomingScript .

Authentication and/or Authorization Scripting Points

Table 1-4 shows the location of the scripting points within the section that determines whether to perform authentication and/or authorization.

Table 1-4 Authentication and Authorization Scripting Points

Action	Explanation
Determines Service to use for authentication and/or authorization.	<p>The Service name defined in the Environment dictionary variable Authentication-Service, and is the same as the Service defined in the Environment dictionary variable Authorization-Service.</p> <p>The Service name referred to by /Radius/DefaultAuthenticationService, and is the same as the Service defined in /Radius/DefaultAuthorizationService.</p>
Performs authentication and/or authorization.	<p>If the Services are the same, perform authentication and authorization.</p> <p>If the Services are different, just perform authentication.</p>
*Executes the Service's incoming script.	A script referred to in /Radius/Services/<Name>/IncomingScript .
Performs authentication and/or authorization.	Based on the Service type defined in /Radius/Services/<Name>/<Type> .
*Executes the Service's outgoing script.	A script referred to in /Radius/Services/<Name>/OutgoingScript .

Table 1-4 Authentication and Authorization Scripting Points (continued)

Action	Explanation
Determines whether to perform authorization.	The Service name defined in /Radius/DefaultAuthorizationService , if different than the Authentication Service.
*Executes the Service’s incoming script.	A script referred to in /Radius/Services/<Name>/IncomingScript .
Performs authorization.	Checks that the Service type is defined in /Radius/Services/<Name>/<Type> .
*Executes the Service’s outgoing script.	A script referred to in /Radius/Services/<Name>/OutgoingScript .

Session Management

The Session Management feature requires the client (NAS or proxy) to send all RADIUS accounting requests to the Cisco Prime AR server performing session management. (The only exception is if the clients are USR/3Com Network Access Servers configured to use the USR/3Com RADIUS resource management feature.) This information is used to keep track of user sessions, and the resources allocated to those sessions.

When another accounting RADIUS server needs this accounting information, the Cisco Prime AR server performing session management might proxy it to this second server.

The **count-session** **lr all** command helps to count the total sessions in Cisco Prime AR. The options are similar to the query-session command options. The query-session command displays cached attributes in addition to session details.

Table 1-5 describes how Cisco Prime AR handles session management.

Table 1-5 Session Management Processing

Action	Explanation
Determines whether to perform session management.	The session management defined in the Environment dictionary variable Session-Manager . The session management name referred to in /Radius/DefaultSessionManager .
Performs session management.	Selects Session Manager as defined in /Radius/SessionManagers/<Name> .

This section contains the following topics:

- [Failover by the NAS and Session Management](#)
- [Cross Server Session and Resource Management](#)

Failover by the NAS and Session Management

When a Network Access Server's primary RADIUS server is performing session management, and the NAS determines the server is not responding and begins sending requests to its secondary RADIUS server, the following occurs:

- The secondary server will not know about the current active sessions that are maintained on the primary server. Any resources managed by the secondary server must be distinct from those managed by the primary server, otherwise it will be possible to have two sessions with the same resources (for example, two sessions with the same IP address).
- The primary server will miss important information that allows it to maintain a correct model of what sessions are currently active (because the authentication and accounting requests are being sent to the secondary server). This means when the primary server comes back online and the NAS begins using it, its knowledge of what sessions are active will be out-of-date and the resources for those sessions are allocated even if they are free to allocate to someone else.

For example, the user-session-limit resource might reject new sessions because the primary server does not know some of the users using the resource logged out while the primary server was offline. It might be necessary to release sessions manually using the **aregcmd** command **release-session**.



Note

It might be possible to avoid this situation by having a disk drive shared between two systems with the second RADIUS server started up once the primary server has been determined to be offline. For more information on this setup, contact Technical Support.

Cross Server Session and Resource Management

Cisco Prime AR can manage sessions and resources across AAA Server boundaries. A session can be created by an Access-Request sent to Cisco Prime AR1, and it can be removed by an Accounting-Stop request sent to Cisco Prime AR2, as shown in [Figure 1-1](#). This enables accurate tracking of User and Group session limits across multiple AAA Servers, and IP addresses allocated to sessions are managed in one place.

Figure 1-1 Multiple Cisco Prime AR Server

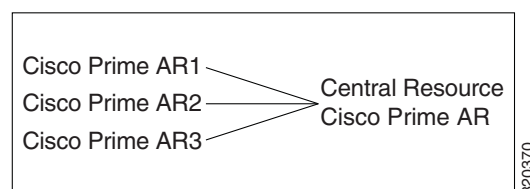

All resources that must be shared across multiple front line Cisco Prime ARs are configured in the Central Resource Cisco Prime AR. Resources that are not shared can still be configured at each front line Cisco Prime AR.

When the front line Cisco Prime AR receives the access-request, it does the regular AA processing. If the packet is not rejected and a Central Resource Cisco Prime AR is also configured, the front line Cisco Prime AR will proxy the packet¹ to the configured Central Resource Cisco Prime AR. If the Central

1. The proxy packet is actually a resource allocation request, not an Access Request.

Resource Cisco Prime AR returns the requested resources, the process continues to the local session management (if local session manager is configured) for allocating any local resources. If the Central Resource Cisco Prime AR cannot allocate the requested resource, the packet is rejected.

When the Accounting-Stop packet arrives at the frontline Cisco Prime AR, Cisco Prime AR does the regular accounting processing. Then, if the front line Cisco Prime AR is configured to use Central Resource Cisco Prime AR, a proxy packet will be sent to Central Resource Cisco Prime AR for it to release all the allocated resources for this session. After that, any locally allocated resources are released by the local session manager.

Session-Service Service Step and Radius-Session Service

A new Service step has been added in the processing of Access-Request and Accounting packets. This is an additional step after the AA processing for Access packet or Accounting processing for Accounting packet, but before the local session management processing. The Session-Service should have a service type of radius-session.

An environment variable Session-Service is introduced to determine the Session-Service dynamically. You can use a script or the rule engine to set the Session-Service environment variable.

Configure Front Line Cisco Prime Access Registrar

To use a Central Resource server, the DefaultSessionService property must be set or the Session-Service environment variable must be set through a script or the rule engine. The value in the Session-Service variable overrides the DefaultSessionService.

The configuration parameters for a Session-Service service type are the same as those for configuring a radius service type for proxy, except the service type is *radius-session*.

The configuration for a Session-Service Remote Server is the same as configuring a proxy server.

```
[ //localhost/Radius ]
  Name = Radius
  Description =
  Version = 6.0
  IncomingScript =
  OutgoingScript =
  DefaultAuthenticationService = local-users
  DefaultAuthorizationService = local-users
  DefaultAccountingService = local-file
  DefaultSessionService = Remote-Session-Service
  DefaultSessionManager = session-mgr-1

[ //localhost/Radius/Services ]
  Remote-Session-Service/
    Name = Remote-Session-Service
    Description =
    Type = radius-session
    IncomingScript =
    OutgoingScript =
    OutagePolicy = RejectAll
    OutageScript =
    MultipleServersPolicy = Failover
    RemoteServers/
      1. central-server

[ //localhost/Radius/RemoteServers ]
  central-server/
    Name = central-server
    Description =
    Protocol = RADIUS
```



```

IPAddress = 209.165.200.224
Port = 1645
ReactivateTimeInterval = 300000
SharedSecret = secret
Vendor =
IncomingScript =
OutgoingScript =
MaxTries = 3
InitialTimeout = 2000
AccountingPort = 1646

```

Configure Central Cisco Prime AR

Resources at the Central Resource server are configured the same way as local resources are configured. These resources are local resources from the Central Resource server's point of view.

Script Processing Hierarchy

For request packets, the script processing order is from the most general to the most specific. For response packets, the processing order is from the most specific to the most general.

[Table 1-6](#), [Table 1-7](#), and [Table 1-8](#) show the overall processing order and flow: (1-6) Incoming Scripts, (7-11) Authentication/Authorization Scripts, and (12-17) Outgoing Scripts.



Note

The client and the NAS can be the same entity, except when the immediate client is acting as a proxy for the actual NAS.

Table 1-6 Cisco Prime AR Processing Hierarchy for Incoming Scripts

Overall Flow Sequence	Incoming Scripts
1)	Radius.
2)	Vendor of the immediate client.
3)	Immediate client.
4)	Vendor of the specific NAS.
5)	Specific NAS.
6)	Service.

Table 1-7 Cisco Prime AR Processing Hierarchy for Authentication/Authorization Scripts

Overall Flow Sequence	Authentication/Authorization Scripts
7)	Group Authentication.
8)	User Authentication.
9)	Group Authorization.
10)	User Authorization.
11)	Session Management.

Table 1-8 Cisco Prime AR Processing Hierarchy for Outgoing Script

Overall Flow Sequence	Outgoing Scripts
12)	Service.
13)	Specific NAS.
14)	Vendor of the specific NAS.
15)	Immediate client.
16)	Vendor of the immediate client.
17)	Radius.

RADIUS Protocol

Cisco Prime AR is based on a client/server model, which supports AAA (authentication, authorization, and accounting). The *client* is the Network Access Server (NAS) and the *server* is Cisco Prime AR. The client passes user information on to the RADIUS server and acts on the response it receives. The *server*, on the other hand, is responsible for receiving user access requests, authenticating and authorizing users, and returning all of the necessary configuration information the client can then pass on to the user.

The protocol is a simple packet exchange in which the NAS sends a request packet to the Cisco Prime AR with a name and a password. Cisco Prime AR looks up the name and password to verify it is correct, determines for which dynamic resources the user is authorized, then returns an accept packet that contains configuration information for the user session (Figure 1-2).

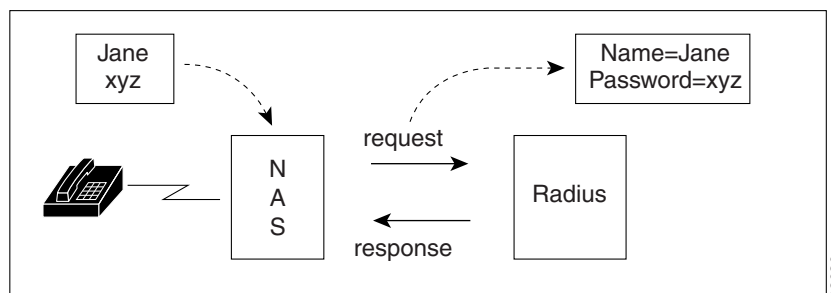
Figure 1-2 Packet Exchange Between User, NAS, and RADIUS

Cisco Prime AR can also reject the packet if it needs to deny network access to the user. Or, Cisco Prime AR can issue a challenge that the NAS sends to the user, who then creates the proper response and returns it to the NAS, which forwards the challenge response to Cisco Prime AR in a second request packet.

In order to ensure network security, the client and server use a *shared secret*, which is a string they both know, but which is never sent over the network. User passwords are also encrypted between the client and the server to protect the network from unauthorized access.

This section contains the following topics:

- [Steps to Connection](#)
- [Types of RADIUS Messages](#)

- [Proxy Servers](#)

Steps to Connection

Three participants exist in this interaction: the user, the NAS, and the RADIUS server.

Setting up the connection

To describe the receipt of an access request through the sending of an access response:

-
- Step 1** The user, at a remote location such as a branch office or at home, dials into the NAS, and supplies a name and password.
 - Step 2** The NAS picks up the call and begins negotiating the session.
 - a. The NAS receives the name and password.
 - b. The NAS formats this information into an Access-Request packet.
 - c. The NAS sends the packet on to the Cisco Prime AR server.
 - Step 3** The Cisco Prime AR server determines what hardware sent the request (NAS) and parses the packet.
 - a. It sets up the Request dictionary based on the packet information.
 - b. It runs any incoming scripts, which are user-written extensions to Cisco Prime AR. An incoming script can examine and change the attributes of the request packet or the environment variables, which can affect subsequent processing.
 - c. Based on the scripts or the defaults, it chooses a service to authenticate and/or authorize the user.
 - Step 4** Cisco Prime AR's authentication service verifies the username and password is in its database. Or, Cisco Prime AR delegates the authentication (as a proxy) to another RADIUS server, an LDAP, or TACACS server.
 - Step 5** Cisco Prime AR's authorization service creates the response with the appropriate attributes for the user's session and puts it in the Response dictionary.
 - Step 6** If you are using Cisco Prime AR session management at your site, the Session Manager calls the appropriate Resource Managers that allocate dynamic resources for this session.
 - Step 7** Cisco Prime AR runs any outgoing scripts to change the attributes of the response packet.
 - Step 8** Cisco Prime AR formats the response based on the Response dictionary and sends it back to the client (NAS).
 - Step 9** The NAS receives the response and communicates with the user, which might include sending the user an IP address to indicate the connection has been successfully established.
-

Types of RADIUS Messages

The client/server packet exchange consists primarily of the following types of RADIUS messages:

- Access-Request—sent by the client (NAS) requesting access
- Access-Reject—sent by the RADIUS server rejecting access
- Access-Accept—sent by the RADIUS server allowing access

- **Access-Challenge**—sent by the RADIUS server requesting more information in order to allow access. The NAS, after communicating with the user, responds with another Access-Request.

When you use RADIUS accounting, the client and server can also exchange the following two types of messages:

- **Accounting-Request**—sent by the client (NAS) requesting accounting
- **Accounting-Response**—sent by the RADIUS server acknowledging accounting

This section contains the following topics:

- [Packet Contents](#)
- [The Attribute Dictionary](#)

Packet Contents

The information in each RADIUS message is encapsulated in a UDP (User Datagram Protocol) data packet. A packet is a block of data in a standard format for transmission. It is accompanied by other information, such as the origin and destination of the data.

[Table 1-9](#) lists a description of the five fields in each message packet.

Table 1-9 RADIUS Packet Fields

Fields	Description
Code	Indicates message type: Access-Request, Access-Accept, Access-Reject, Access-Challenge, Accounting-Request, or Accounting-Response.
Identifier	Contains a value that is copied into the server's response so the client can correctly associate its requests and the server's responses when multiple users are being authenticated simultaneously.
Length	Provides a simple error-checking device. The server silently drops a packet if it is shorter than the value specified in the length field, and ignores the octets beyond the value of the length field.
Authenticator	Contains a value for a Request Authenticator or a Response Authenticator. The Request Authenticator is included in a client's Access-Request. The value is unpredictable and unique, and is added to the client/server shared secret so the combination can be run through a one-way algorithm. The NAS then uses the result in conjunction with the shared secret to encrypt the user's password.
Attribute(s)	Depends on the type of message being sent. The number of attribute/value pairs included in the packet's attribute field is variable, including those required or optional for the type of service requested.

The Attribute Dictionary

The Attribute dictionary contains a list of preconfigured authentication, authorization, and accounting attributes that can be part of a client's or user's configuration. The dictionary entries translate an attribute into a value Cisco Prime AR uses to parse incoming requests and generate responses. Attributes have a human-readable name and an enumerated equivalent from 1-255.

Sixty three standard attributes exist, which are defined in RFC 2138 and 2139. There also are additional vendor-specific attributes that depend on the particular NAS you are using.

Some sample attributes include:

- User-Name—the name of the user
- User-Password—the user's password
- NAS-IP-Address—the IP address of the NAS
- NAS-Port—the NAS port the user is dialed in to
- Framed Protocol—such as SLIP or PPP
- Framed-IP-Address—the IP address the client uses for the session
- Filter-ID—vendor-specific; identifies a set of filters configured in the NAS
- Callback-Number—the actual callback number.

Proxy Servers

Any one or all of the RADIUS server's three functions: authentication, authorization, or accounting can be subcontracted to another RADIUS server. Cisco Prime AR then becomes a *proxy server*. Proxying to other servers enables you to delegate some of the RADIUS server's functions to other servers.

You could use Cisco Prime AR to “proxy” to an LDAP server for access to directory information about users in order to authenticate them. [Figure 1-3](#) shows user `joe` initiating a request, the Cisco Prime AR server proxying the authentication to the LDAP server, and then performing the authorization and accounting processing in order to enable `joe` to log in.

Figure 1-3 Proxying to an LDAP Server for Authentication

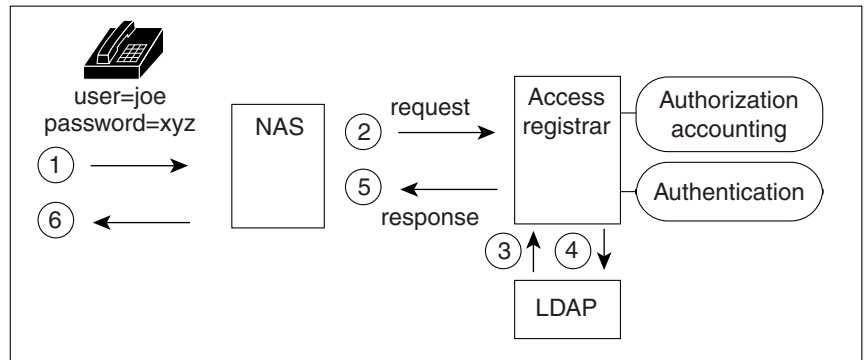

Service and Ports Used in Cisco Prime AR

Secure Shell Service

SSH Daemon(SSHD) is the daemon program which is used for ssh(1). It provides secure shell encrypted communications between two hosts over network.

In case of Cisco Prime AR, SSH is used to connect to Cisco Prime AR server and configure Cisco Prime AR using CLI.

Ports

The following table lists out the port numbers that are used for various services in Cisco Prime AR for AAA:

Table 1-10 Ports Used in Cisco Prime AR

Names	Description	Port Numbers	Service of the Ports	Access from Network Node	Configuration Setting	Protocol Name and Reference
AR AAA Service	The RADIUS packet listener uses these ports by default.	Solaris: 1645-udp Linux: 1812-udp	RADIUS AA	Network Access Server	You can change the default or define new RADIUS port numbers under <i>/Radius/Advanced/Ports</i> in the CLI and <i>Configuration > Advanced > Ports</i> in the GUI.	RADIUS AA (Authentication, and Authorization) service.
		Solaris: 1646-udp radacct Linux: 1813-udp radacct	RADIUS Accounting	Network Access Server	You can change the default or define new RADIUS port numbers under <i>/Radius/Advanced/Ports</i> in the CLI and <i>Configuration > Advanced > Ports</i> in the GUI.	RADIUS Accounting service. Refer to RFC 6733 for more information.
		3799/udp	RADIUS Dynamic Authorization (CoA/PoD)	Network Access Server	N/A	RADIUS Dynamic authorization which is used with (CoA/PoD) packet types.
AR AAA Service	The TACACS+ packet listener uses this port by default.	49/tcp	TACACS+	Network Access Server	You can change the default or define new RADIUS port numbers under <i>/Radius/Advanced/Ports</i> in the CLI and <i>Configuration > Advanced > Ports</i> in the GUI.	TACACS+ based on AAA service (Authentication, Authorization, and Accounting). Refer to RFC 1491 for more information.

Table 1-10 Ports Used in Cisco Prime AR

Names	Description	Port Numbers	Service of the Ports	Access from Network Node	Configuration Setting	Protocol Name and Reference
AR AAA Service	The DIAMETER packet listener uses these ports by default.	3868/tcp	DIAMETER	Network Access Server	You can enable or disable this service in <i>Radius/Advanced/Diameter/IsDiameterEnabled</i> .	DIAMETER AA Service (Authentication, and Authorization) by tcp protocol. Refer to RFC 4005 for more information.
		3868/sctp	DIAMETER	Network Access Server	You can enable or disable this service in <i>Radius/Advanced/Diameter/IsDiameterEnabled</i> .	DIAMETER AA Service (Authentication, and Authorization) by SCTP protocol.
AR MCD Server	MCD is used to store Cisco Prime AR configuration.	2786/tcp	MCD database Server	This service can be accessed from local host by Cisco Prime AR radius and server agent process.	N/A	Proprietary IPC mechanism.
AR Server Agent	AR Server Agent is used to log all the activities of Cisco Prime AR processes.	2785/tcp	Internal IPC mechanism	This service can be accessed from local host by Cisco Prime AR radius and server agent process.	N/A	Proprietary IPC mechanism.

Table 1-10 Ports Used in Cisco Prime AR

Names	Description	Port Numbers	Service of the Ports	Access from Network Node	Configuration Setting	Protocol Name and Reference
AR GUI Service	Cisco Prime AR GUI processes use these ports by default.	8080/tcp	AR HTTP service	This service is accessible from any end user desktop browser using http protocol.	You can change the default port numbers in editing the <i>server.xml</i> file.	Standard HTTP protocol
		8443/tcp	AR HTTPS service	This service is accessible from any end user desktop browser using https protocol.	You can change the default port numbers in editing the <i>server.xml</i> file.	Standard HTTPS protocol
		8005/tcp	Internally used by Apache Tomcat container	Local host	You can change the default port numbers in editing the <i>server.xml</i> file..	To shutdown Tomcat JVM service instance.
		8009/tcp	Apache Tomcat container AJP 1.3 Connector	Local host	You can change the default port numbers in editing the <i>server.xml</i> file.	Apache JServ protocol. AJP 1.3 Connector.
SNMP Master Agent	SNMP Packet listener supports these ports by default.	161/udp	Simple Net Management Protocol	This service is accessible from any network management host.	Refer to net-snmp documentation for more information.	SNMP MIBs server
		162/udp	Traps for SNMP	This service is accessible to any SNMP trap client when you want to use net-snmp snmptrap daemon as a SNMP trap server.	Refer to Configuring Traps for more information.	SNMP trap server



CHAPTER 2

Using the aregcmd Commands

This chapter describes how to use each of the **aregcmd** commands. The Cisco Prime AR **aregcmd** command is a command-line based configuration tool. It allows you to set any Cisco Prime Access Registrar (Cisco Prime AR) configurable option, as well as, start and stop the server and check statistics.

This chapter contains the following sections:

- [General Command Syntax](#)
- [aregcmd Commands](#)
- [aregcmd Command Logging](#)
- [aregcmd Command Line Editing](#)
- [aregcmd Error Codes](#)

General Command Syntax

Cisco Prime AR stores its configuration information in a hierarchy. Using the **aregcmd** command **cd** (change directory), you can move through this information in the same manner as you would through any hierarchical file system. Or you can supply full pathnames to these commands to affect another part of the hierarchy, and thus avoid explicitly using the **cd** command to change to that part of the tree.

- **aregcmd** command parsing is case *insensitive*, which means you can use upper or lowercase letters to designate elements. In addition, when you reference existing elements in the configuration, you need only specify enough of the element's name to distinguish it from the other elements at that level. For example, instead of entering **cd Administrators**, you can enter **cd ad** when no other element at the current level begins with **ad**.
- **aregcmd** command parsing is command-line order *dependent*; that is, the arguments are interpreted based on their position on the command line. To indicate an empty string as a place holder on the command line, use either single (') or double quotes ("). In addition, when you use any arguments that contain spaces, you must quote the arguments. For example, when you use the argument, "Local Users," you must enclose the phrase in quotes.

The **aregcmd** command can contain a maximum of 255 characters when specifying a parameter and 511 characters for the entire command.

The **aregcmd** command syntax is:

```
aregcmd [-C <clustername>] [-N <adminname>] [-P <adminpassword>] [-V]
[-f <scriptfile>] [-l <directoryname>] [-n] [<command> [<args>]] [-p] [-q] [-v]
```

- **-C**—Specifies the name of the cluster to log into by default

- **-N**—Specifies the name of the administrator
- **-P**—Specifies the password
- **-V**—Specifies view-only mode
- **-f**—Specifies a file that can contain a series of commands
- **-l**—Specifies a directory where the Cisco Prime AR license file is stored and returns information about licensed components
- **-n**—Turns off prefix mode
- **-p**—Specifies prefix mode
- **-q**—Turns off verbose mode
- **-v**—Specifies verbose mode

**Note**

The verbose (**-v**) and prefix (**-p**) modes are on by default when you run **aregcmd** interactively (for example, not entered on the command line or not running commands from a script file). Otherwise, verbose and prefix modes are off.

When you include a command (with the appropriate arguments) on the command line, **aregcmd** runs only that one command and saves any changes.

This section contains the following topics:

- [View-Only Administrator Mode](#)
- [Configuration Objects](#)
- [aregcmd Command Performance](#)

View-Only Administrator Mode

Previous releases of Cisco Prime AR provided only *super-user* administrative access. If you were able to log in to **aregcmd**, you could do anything to the system, including starting and stopping the system and changing the configuration. Cisco Prime AR provides view-only administrative access. View-only access restricts an administrator to only being able to observe the system and prevents that user from making changes.

View-only access can be encountered in three ways:

- Specific administrators can be restricted to view-only access whenever they log in.
- Administrators not restricted to view-only access can choose to start **aregcmd** in a view-only mode. This might be used when an administrator wants to ensure that he or she does not make any changes.
- When an administrator who is not view-only logs in to a slave server, they will be unable to make changes to any parts of the configuration other than **/Radius/Replication**, **/Radius/Advanced/Ports**, **/Radius/Advanced/Interfaces** or the properties in **/Radius/Advanced**. This is because the rest of the configuration is replicated from the master server and changes directly to the slave will cause problems.

**Note**

When a user logs in, the system determines whether a user's session is view-only or not. If the configuration is changed after a user has logged in, that change does not take effect until the affected user logs out and logs back in.

ViewOnly Property

The ViewOnly property has been added to the Administrators configuration. The default setting for the ViewOnly property is FALSE. The following shows the default setting for the **admin** user:

```
cd /Administrators/admin
```

```
[ //localhost/Administrators/admin ]
Name = admin
Description =
Password = <encrypted>
ViewOnly = FALSE
```

You can designate specific administrators to be view-only administrators by setting the new ViewOnly property to TRUE.

- If that property is set to TRUE, any time the administrator logs in to **aregcmd** the session will be in view-only mode.
- If set to FALSE, when the administrator logs in to a master server, the session will be full super-user capability.

If the administrator logs in to a slave, they only part of the configuration they will be able to modify is that part under **/Radius/Replication**, **/Radius/Advanced/Ports**, **/Radius/Advanced/Interfaces** or the properties in **/Radius/Advanced**.

When in a view-only session, the following commands will cause an error: **add**, **delete**, **set**, **unset**, **insert**, **validate**, **save**, **start**, **stop**, **reload**, **reset-stats**, **release-sessions**, and **trace**. The following error message will be displayed:

```
316 Command failed: session is ViewOnly
```

When in a slave server session, the following commands will cause an error when the object or property being operated on is not under **/Radius/Replication**, **/Radius/Advanced/Ports**, **/Radius/Advanced/Interfaces** or the properties in **/Radius/Advanced**: **add**, **delete**, **set**, **unset**, and **insert**. The following error message will be displayed:

```
317 Command failed: session is ViewOnly
```

Configuration Objects

The Cisco Prime AR **aregcmd** command lets you manipulate configuration objects, that define properties or the behavior of the RADIUS server, such as valid administrators and types of services. For descriptions of the those objects, see [Chapter 4, “Cisco Prime Access Registrar Server Objects.”](#)

aregcmd Command Performance

You can impact **aregcmd** command performance and server response time by having Cisco Prime AR userlists that contain more than 10,000 users. Cisco Prime AR userlists were not designed to contain 10,000 users in any one list.

If you must provide service for groups greater than 10000 users, Cisco recommends that you use an external data store such as an **LDAP directory** or an **Oracle database**. If you are unable to use an external data store, create multiple userlists instead, keeping each userlist under 10,000 users.

Multiple userlists require multiple services (one for each userlist), because a service cannot reference more than one userlist. The multiple services can then be combined using the Service Grouping feature with ResultRule, OR, as follows:

```
[ //localhost/Radius/Services/GroupService ]
  Name = GroupService
  Description =
  Type = group
  IncomingScript~ =
  OutgoingScript~ =
  ResultRule = OR
  GroupServices/
  1. UserService1
  2. UserService2
  3. UserService3
```

RPC Bind Services

The Cisco Prime AR server and the **aregcmd** CLI requires RPC services to be running before the server is started. If the RPC services are stopped, you must restart RPC services, then restart the Cisco Prime AR server.

Use the following commands to restart RPC services:

```
arserver stop
```

```
/etc/init.d/rpc start
```

```
arserver start
```

If RPC services are not running, the following message is displayed when you attempt to start aregcmd:

```
Login to aregcmd fails with the message:
400 Login failed
```

aregcmd Commands

This section contains the complete list of **aregcmd** commands. You can use them on the command line or insert them into scripts. The commands are listed alphabetically.

This section contains the following topics:

- [add](#)
- [cd](#)
- [delete](#)
- [exit](#)
- [filter](#)
- [find](#)
- [help](#)
- [insert](#)
- [login](#)
- [logout](#)

- [ls](#)
- [next](#)
- [prev](#)
- [pwd](#)
- [query-sessions](#)
- [quit](#)
- [release-sessions](#)
- [reload](#)
- [reset-stats](#)
- [save](#)
- [set](#)
- [start](#)
- [stats](#)
- [status](#)
- [stop](#)
- [tacacs-stats](#)
- [tacacs-reset-stats](#)
- [trace](#)
- [trace-file-count](#)
- [unset](#)
- [validate](#)

add

Use the **aregcmd** command **add** to create new elements in the configuration. The **add** command is context sensitive, which means the type of element added is determined by the current context, or the path specified as the first parameter. The **add** command has one required argument; the name of the element you wish to add. You can also provide other parameters, or you can supply this information after **aregcmd** has added the new element. The optional second argument is a description of the element.

The syntax is:

```
add [<path>/]<name> [...]
```

cd

Use the **aregcmd** command **cd** to change the working context, or level in the configuration hierarchy. When you use the **cd** command without any parameters, it returns you to the root of the tree. When you use the optional path argument, you can specify a new context. To change to a higher level in the tree hierarchy, use the “..” syntax (as you would in a UNIX file system). When you change to a new context, **aregcmd** displays the contents of the new location, when you are using the command in interactive mode, or if verbose mode is on.

The syntax is:

```
cd [<path>]
```

delete

Use the **aregcmd** command **delete** to remove an element from the configuration hierarchy. You cannot remove properties on an element; you can only remove entire elements. The **delete** command is recursive; that is, it will remove any subelements contained within an element being removed. When the element is in the current context, you need only provide the name of the element to be deleted. You can optionally provide a complete path to an element elsewhere in the configuration hierarchy.

The syntax is:

```
delete [<path>/]<name>
```

exit

Use the **aregcmd** command **exit** to terminate your **aregcmd** session. If you have any unsaved modifications, Cisco Prime AR asks if you want to save them before exiting. Any modifications you don't choose to save are lost.

The syntax is:

```
exit
```

filter

Use the **aregcmd** command **filter** to display a selected view of a list. You can use the **filter** command to present only the elements of a list that have properties equal to the value you specify. You can also use the **filter** command to restore the view of the list after it has been filtered.

When using the **filter** command, you must provide a property name and a value, and you can optionally provide the path to the list. Cisco Prime AR displays a list with only those elements that have a value equal to the specified value. When you want to filter the current context, you can omit the path argument.

The **filter** command is *sticky*, in that, after you have filtered a list, you must explicitly unfilter it before you can view the complete list again. To restore the unrestricted view of the list, use the **filter** command and specify the string **all**. To restore the list in current context, you can omit the pathname.

The syntax is:

```
filter [<path>] <property> <value>
```

or

```
filter [<path>] all
```

find

Use the **aregcmd** command **find** to locate a specific item in a list. The **find** command takes one required argument, which is a full or partial pathname. After you use the command, Cisco Prime AR displays a page beginning with the entry that most closely matches the pathname you provided.

The syntax is:

```
find <path>
```

help

Use the **aregcmd** command **help** (with no argument specified) to display a brief overview of the command syntax. When you specify the name of a command, Cisco Prime AR displays help for only that command.

The syntax is:

```
help [<command>]
```

insert

Use the **aregcmd** command **insert** to add an item anywhere in ordered list. The required parameters are the numeric index of the position in the list in which you want to insert the new item, and the item value. When the list to which you are adding is not the current context, you can specify the complete path to the position in the list by prepending the path for the list to the numeric index. After the new value has been inserted into the list, Cisco Prime AR appropriately renumbers the list.

The syntax is:

```
insert [<path>/]<index> <value>
```

This command applies to lists of servers by index and the Resource Managers list in Session Managers.

login

Use the **aregcmd** command **login** to connect to a cluster, which contains the RADIUS server and definition of the authorized administrators. When you do not specify the cluster, admin name, and password, **aregcmd** prompts you for them.

When you are currently logged in to a cluster, the **login** command allows you to connect to another cluster. When you have changes in the current cluster that you have not saved, **aregcmd** asks if you want to save them before logging into another cluster. Any changes you do not save are lost.

After you successfully log in, and if the server is running, Cisco Prime AR displays the cluster server's health. Note, to log in to a cluster, the Cisco Prime AR Server Agent for that cluster must be running.

The syntax is:

```
login [<cluster> [<name> [<password>]]]
```

logout

Use the **aregcmd** command **logout** to log out of the current cluster. After you log out, you have to log in to make any modifications to the configuration hierarchy, or to manage the server(s). When you have any unsaved modifications, Cisco Prime AR asks if you want to save them before logging out. Any modifications you do not choose to save are lost.

The syntax is:

```
logout
```

ls

Use the **aregcmd** command **ls** to list the contents of a level in the configuration hierarchy. This command works much like the UNIX **ls** command. When you use it without any parameters, it lists the items in the current context. When you specify a path, it lists the elements found in that context. When you use the **-R** argument, it recursively lists all of the elements in and below the specified (or current) context.

For similar commands, refer to the **next** and **prev** commands.

The syntax is:

```
ls [-R] [<path>]
```

next

Use the **aregcmd** **next** command to review the remaining pages produced from the **ls** command. Every time you use the **cd** command, it automatically invokes the **ls** command to display the contents of the location. When the output from the **ls** command is more than one page (a page is about 24 lines) in length, Cisco Prime AR displays only the first page.



Note

ls pages only user-added objects such as Users, UserLists, and attributes.

The **next** command takes an optional path and count. The path specifies the context in which you wish to see the next page and the count specifies the number of lines you wish to see. When you use the **next** command without the path, Cisco Prime AR uses the current context. When you do not specify a count, Cisco Prime AR uses the last count value you used with the **next** or **prev** command. If you never specify a count, Cisco Prime AR uses the default value, which is 20.

Note, the current page for a context is *sticky*. This means, for example, when you use the **next** command to view entries 20 through 30, until you use the **next** or **prev** command on the same context, you will continue to see these entries even if you use the **cd** command to change to a different context, then return to the original.

The syntax is:

```
next [<path>] [<count>]
```

prev

Use the **aregcmd** command **prev** to page backwards through the output of the **ls** command. It behaves much like the **next** command, in that it takes an optional path identifying a context to display and a count parameter indicating how many lines to display.

The syntax is:

```
prev [<path>] [<count>]
```

pwd

Use the **aregcmd** command **pwd** to display the absolute pathname of the current context (level in the configuration hierarchy).

The syntax is:

pwd

query-sessions

Use the **aregcmd** command **query-sessions** to query the server about the currently active user sessions. You can request information about all of the active sessions or just those sessions that match the type you specify.

The syntax is:

```
query-sessions <path> [all]
```

or

```
query-sessions <path> with-<type> <value> [send-CoA [with-profile <profile name>] ]
```

or

```
query-sessions <path> with-Attribute <name> <value> [send-CoA [with-profile <profile name>] ]
```

Where <path> is the path to the server, Session Manager, or Resource Manager to query and **with-<type>** is one of the following: **with-NAS**, **with-User**, **with-IP-Address**, **with-IPX-Network**, **with-USR-VPN**, **with-Key**, **with-ID** or **with-Age**. The optional [**with-profile** <profile name>] parameter indicates a profile name as configured in **/Radius/Profiles**.

The **query-sessions** command with an optional [**send-CoA**] at the end causes the Cisco Prime AR server to send a Change of Authorization (CoA) request to the client. The CoA request includes the CoA attributes configured for the client. When the optional profile name is also included in the command, the Cisco Prime AR server includes the attribute-value (AV) pairs from the corresponding profile in **/Radius/Profiles** in the CoA request.

quit

Use the **aregcmd** command **quit** to terminate your **aregcmd** session. You can use it interchangeably with the **exit** command.

The syntax is:

```
quit
```

When you quit the **aregcmd** command, if you have made changes, the Cisco Prime AR server asks if you want to save the changes. Any unsaved changes are lost.

release-sessions

Use the **aregcmd** command **release-sessions** to request the server to release one or more currently active user sessions. This command might be useful, for example, in the case where you have taken a NAS offline, however, the server believes user sessions for that NAS are still active.

The syntax is one of:

```
release-sessions <path> all
```

or

```
release-sessions <path> with-<type> <value> [send-pod] [send-notification]
```

or

release-sessions <path> **with-Attribute** <name> <value> [**send-pod**] [**send-notification**]

Where <path> is the path to the server, Session Manager, or Resource Manager to query and **with-<type>** is one of the following: **with-NAS**, **with-User**, **with-IP-Address**, **with-IPX-Network**, **with-USR-VPN**, **with-Key**, or **with-ID**.

The optional [**send-pod** <send notification>] parameter sends the disconnect packet to the NAS to clear sessions and an Accounting-Stop notification to the client listed in the session record.

The optional **with-Attribute** parameter enables release a session based on a specific attribute and value.

reload

Use the **aregcmd** command **reload** to stop the server (when it is running), and then immediately start the server, forcing it to reread its configuration information. When you have modified the configuration hierarchy, Cisco Prime AR asks you if you want to save your changes before restarting the server. You *must* save your changes in order for the reloaded server to be able to use them.

The syntax is:

reload

reset-stats

Use the **aregcmd** command **reset-stats** to reset all server statistics displayed with the **stats** command. The **reset-stats** command also resets SNMP counters.

The **reset-stats** command provides a way of resetting the server statistics without having to reload or restart the server.

The syntax is:

reset-stats

save

Use the **aregcmd** command **save** to validate the changes you made and commit them to the configuration database, if no errors are found.



Note

Using the **save** command does not automatically update the running server. To update the server, you must use the **reload** command.

The syntax is:

save

Table 2-1 lists the RADIUS server objects and the effect of Dynamic Updates upon them.

Table 2-1 Dynamic Updates Effect on Radius Server Objects

Object	Add	Modify or Delete
Radius	Yes	Yes
UserLists	Yes	Yes
UserGroups	Yes	Yes
Policies	Yes	Yes
Clients	Yes	Yes
Vendors	Yes	Yes
Scripts	Yes	Yes
Services	Yes	Yes
SessionManagers	Yes	No
ResourceManagers	Yes	No
Profiles	Yes	Yes
Rules	Yes	Yes
Translations	Yes	Yes
TranslationGroups	Yes	Yes
RemoteServers	Yes	No
Replication	Yes	Yes
Advanced	Yes	Yes
SNMP	No	No
Ports	No	No
Interfaces	No	No

set

Use the **aregcmd** command **set** to provide values for properties on existing configuration elements. You only need to provide the **set** command with the name of the property you wish to set (or just enough of the name to distinguish it from other properties) and the new value for that property. It also applies to the **Profiles** attribute list, the Rules attributes list, the enumeration list in the Attribute dictionary, and the **LDAPtoRadiusMappings** and **LDAPtoEnvironmentMappings** mappings.

The **set** command can also be used to order servers in a list. To specify a new position in a list for a server, use the **set** command and provide the numeric position of the server and the server's name.

The syntax is:

```
set [<path>/]<property> <value>
```

When the list is a list of servers by index, the syntax is:

```
set [<path>/]<index> <server name>
```



Note If the index is already in use, the old server name will be replaced by the new server name.

To remove a value from a property (make a property equal to NULL), use a pair of single or double quotes as the value, as shown below:

```
set <property> ""
```

When you need to set an attribute to a value that includes a space, you must double-quote the value, as in the following:

```
set Framed-Route "192.168.1.0/24 192.168.1.1"
```

start

Use the **aregcmd** command **start** to enable the server to handle requests. When the configuration hierarchy has been modified, Cisco Prime AR asks you if you want to save the changes before starting the server.

The syntax is:

```
start
```

stats

Use the **aregcmd** command **stats** to provide statistical information on the specified server. You can only issue this command when the server is running.

Note that **aregcmd** supports the **PAGER** environment variable. When the **aregcmd stats** command is used and the **PAGER** environment variable is set, the **stats** command output is displayed using the program specified by the **PAGER** environment variable.

The syntax is:

```
stats
```

The following is an example of the statistical information provided after you issue the **stats** command:

```
RemoteServer statistics for:ServerA, 209.165.201.1, port 1645
  active = TRUE
  maxTries = 3
  RTTAverage = 438ms
  RTTDeviation = 585ms
  TimeoutPenalty = 0ms
  totalRequestsPending = 0
  totalRequestsSent = 14
  totalRequestsOutstanding = 0
  totalRequestsTimedOut = 0
  totalRequestsAcknowledged = 14
  totalResponsesDroppedForNotInCache = 0
  totalResponsesDroppedForSignatureMismatch = 0
  totalRequestsDroppedAfterMaxTries = 0
  lastRequestTime = Mon Feb 18 17:19:46 2012
  lastAcceptTime = Mon Feb 18 17:18:11 2012
```

Table 2-2 lists the statistics displayed by the stats command and the meaning of the values.

Table 2-2 aregcmd stats Information

Stats Value	Meaning
RemoteServer statistics for:	Provides server's type, name, IP address, and port used
active	Indicates whether the server was active (not in a down state)
maxTries	Number of retry attempts to be made by the RemoteServer Object based on the RemoteServer's <i>maxTries</i> property setting
RTTAverage	Average round trip time since the last server restart
RTTDeviation	Indicates a standard deviation of the RTTAverage
TimeoutPenalty	Indicates any change made to the initial timeout default value
totalRequestsPending	Number of requests currently queued
totalRequestsSent	Number of requests sent since the last server restart Note totalRequestsSent should equal the sum of totalRequestsOutstanding and totalRequestsAcknowledged.
totalRequestsOutstanding	Number of requests currently proxied that have not yet returned
totalRequestsTimedOut	Number of requests that have timed out since last server restart or number requests not returned from proxy server within the [configured] initial timeout interval
totalRequestsAcknowledged	Number of responses received since last server restart
totalResponsesDroppedForNotInCache	Number of responses dropped because their ID did not match the ID of any Pending requests
totalResponsesDroppedForSignatureMismatch	Number of responses dropped because their response authenticator did not decode to the correct shared secret
totalRequestsDroppedAfterMaxTries	Number of requests dropped because no response was received after retrying the configured number of times. This value is different from totalRequestsTimedOut because using the default configuration values, no response within 2000 ms bumps the TimedOut counter, but it waits 14000 ms (2000 + 4000 + 8000) to bump this counter.

Table 2-2 *aregcmd stats Information (continued)*

Stats Value	Meaning
lastRequestTime	Date and time of last proxy request
lastAcceptTime	Date and time of last ACCEPT response to a client

status

Use the **aregcmd** command **status** to learn whether or not the specified server has been started. When the server is running, Cisco Prime AR displays its health.

The syntax is:

```
status
```

stop

Use the **aregcmd** command **stop** to cause the server to no longer accept requests.

The syntax is:

```
stop
```

tacacs-stats

Use the **aregcmd** command **tacacs-stats** to provide statistical information of TACACS+.

The syntax is:

```
tacacs-stats
```

The following is an example of the statistical information provided after you issue the **tacacs-stats** command:

```
Global Tacacs+ Statistics
  serverStartTime = Thu Jun 14 04:15:50 2012
  serverResetTime = Thu Jun 14 04:15:50 2012
  serverState = Running
  totalPacketsReceived = 34
  totalPacketsSent = 34
  totalRequests = 34
  totalResponses = 34
  totalAuthenticationRequests = 26
  totalAuthenticationAccepts = 2
  totalAuthenticationRejects = 2
  totalAuthenticationChallengeRequests = 6
  totalAuthenticationResponses = 26
  totalAuthorizationRequests = 8
  totalAccountingAccepts = 0
  totalAccountingRejects = 4
  totalAccountingResponses = 4
  totalPacketsInUse = 12
  totalPacketsDropped = 0
  totalPayloadDecryptionFailures = 0
```

See [TACACS Statistics](#) for more information.

tacacs-reset-stats

Use the **aregcmd** command **tacacs-reset-stats** to reset TACACS+ statistics displayed with the **stats** command. The **tacacs-reset-stats** command also resets SNMP counters.

The **tacacs-reset-stats** command provides a way of resetting the TACACS+ statistics without having to reload or restart the server.

The syntax is:

```
tacacs-reset-stats
```

trace

Use the **aregcmd** command **trace** to set the trace level in the specified server to a new value. The trace level governs how much information is displayed about the contents of a packet. When the trace level is zero, no tracing is performed. The higher the trace level, the more information displayed. The highest trace level currently used by the Cisco Prime AR server is trace level 5.



Note

Although the highest **trace** level supported by the Cisco Prime AR server is **trace** level 5, an extension point script might use a higher level. There is no harm in setting the **trace** to a level higher than 5.

The **trace** levels are inclusive, meaning that if you set **trace** to level 3, you will also get the information reported for **trace** levels 1 and 2. If you set trace level 4, you also get information reported for **trace** levels 1, 2, and 3.

When you do not specify a server, Cisco Prime AR sets the **trace** level for all of the servers in the current cluster. When you do not specify a value for the **trace** level, Cisco Prime AR displays the current value of the **trace** level. The default is 0.

The syntax for setting the **trace** level is:

```
trace [<server>] [<level>]
```

Table 2-3 lists the different **trace** levels and the information returned.

Table 2-3 Trace Levels and Information Returned

Trace Level	Information Returned by Trace Command
0	No trace performed
1	Reports when a packet is sent or received or when there is a change in a remote server's status.
2	Indicates the following: <ul style="list-style-type: none"> • Which services and session managers are used to process a packet • Which client and vendor objects are used to process a packet • Detailed remote server information for LDAP and RADIUS, such as sending a packet and timing out • Details about poorly formed packets • Details included in trace level 1

Table 2-3 Trace Levels and Information Returned (continued)

Trace Level	Information Returned by Trace Command
3	<p>Indicates the following:</p> <ul style="list-style-type: none"> • Error traces in TCL scripts when referencing invalid RADIUS attributes. • Which scripts have been executed • Details about local UserList processing • Details included in trace levels 1 and 2
4	<p>Indicates the following:</p> <ul style="list-style-type: none"> • Information about advanced duplication detection processing • Details about creating, updating, and deleting sessions • Trace details about all scripting APIs called • Details included in trace levels 1, 2, and 3
5	<p>Indicates the following:</p> <ul style="list-style-type: none"> • Details about use of the policy engine including: <ul style="list-style-type: none"> – Which rules were run – What the rules did – If the rule passed or failed – Detailed information about which policies were called • Details included in trace levels 1, 2, 3, and 4

trace-file-count

Use the **aregcmd** command **trace-file-count** to change the trace log file count dynamically without requiring a server reload. The syntax is:

```
trace-file-count n
```

Where *n* is a number that specifies the number of trace log files. This function is helpful for debugging situations when you do not want to perform a **reload**.

unset

Use the **aregcmd** command **unset** to remove items from an ordered list. Specify the numeric index of the element to remove. When the ordered list is not the current context, specify the path to the list before specifying the numeric index.

When you remove an item from the list, Cisco Prime AR renumbers the list.

The syntax is:

```
unset [<path>/]<index>
```

This command applies to lists of servers by index, the **Profiles** attribute list, the Rules Attributes list, the enumeration list in the Attribute dictionary, and the **LDAPtoRadiusMappings** and **LDAPtoEnvironmentMappings** mappings.

validate

Use the **aregcmd** command **validate** to check the consistency and validity of the specified server's configuration. If Cisco Prime AR discovers any errors, it displays them.

The syntax is:

```
validate
```

OpenSSL Commands

This section contains a list of **OpenSSL** commands. You can use them on the command line or insert them into scripts.

This section contains the following topics:

- [ecparam](#)
- [req](#)
- [ca](#)

ecparam

Use the **OpenSSL** command **ecparam** to manipulate or generate elliptical curve(EC) parameter files.

The syntax is:

```
ecparam
```

req

Use the **OpenSSL** command **req** to create and process certificate requests.

The syntax is:

```
req
```

ca

Use the **OpenSSL** command **ca** used to sign certificate requests and generate CRLs it also maintains a text database of issued certificates and their status.

The syntax is:

```
ca
```

aregcmd Command Logging

aregcmd now records the commands that are either entered interactively, on the command line, or executed in batch mode. The recorded commands are saved in the **aregcmd_log** file, which resides in the **logs** directory within the Cisco Prime AR installation directory.

For security reasons, **aregcmd** blocks out the actual password that is entered as part of the command and replaces it with `<passwd>`.

In interactive mode, **aregcmd** logs the actions that are taking place in the exit/logout dialog box. The action can be **save** or **not save** if the configuration database has been modified after the last execution of the **save** command.

In non-interactive (batch or command-line) mode, **aregcmd** replaces the empty field with a NULL string.

aregcmd is now installed as a **setgid** program where the group is set to **staff**. This allows a non-root user to run **aregcmd** while still being able to write to the **aregcmd_log** log file. During the installation of the Cisco Prime AR software, you are prompted whether you want to install **aregcmd** with **setuid/setgid** permissions. You must reply “yes” unless you only run **aregcmd** as user **root**.

The following is the format of an entry in the exit/logout dialog box when **not save** has been specified:

```
mm/dd/yyyy HH:MM:SS aregcmd Info Configuration 0 [<clustername> <username>] ( exit )
mm/dd/yyyy HH:MM:SS aregcmd Info Configuration 0 [<clustername> <username>] ( *** New
                                     config is not saved! ...proceed to logout.)
```

The following is sample output of an entry in the exit/logout dialog box when **not save** has been specified:

```
10/12/2012 16:18:56 aregcmd Info Configuration 0 [localhost admin] --> quit
10/12/2012 16:19:02 aregcmd Info Configuration 0 [localhost admin] --> *** New config is
                                     not saved! ...proceed to logout.
```

The following is the format of an entry in the exit/logout dialog box when **save** has been specified:

```
mm/dd/yyyy HH:MM:SS aregcmd Info Configuration 0 [<clustername> <username>] ( exit )
mm/dd/yyyy HH:MM:SS aregcmd Info Configuration 0 [<clustername> <username>] ( *** New
                                     config saved!...proceed to logout.)
```

aregcmd Command Line Editing

Commands entered at the **aregcmd** prompt can be edited with a subset of the standard EMACS-style keystrokes. In addition, the command history can be accessed using the arrow keys on the keyboard. Use the Up arrow to retrieve the previous command and the Down arrow to retrieve the next command. A description of the supported key strokes are shown in [Table 2-4](#).

Table 2-4 *aregcmd Command Line Editing Keystrokes*

Key Stroke	Description
Ctrl A	Go to the beginning of the line.
Ctrl B	Move back one character.
Ctrl D	Delete the character at the cursor.

Table 2-4 *aregcmd Command Line Editing Keystrokes (continued)*

Key Stroke	Description
Ctrl E	Go to the end of the line.
Ctrl F	Move forward one character.
Ctrl N	Retrieve the next line.
Ctrl P	Retrieve the previous line.

aregcmd Error Codes

Table 2-5 lists the error codes used in **aregcmd**.

Table 2-5 *aregcmd Error Codes*

Error Code	Meaning
200	OK
300	Command failed to parse; usually an unbalanced quotation
301	Unknown command; usually caused by a misspelled command
302	Ambiguous command; characters you have entered select more than one command
303	Not logged in; you have logged out of aregcmd and attempted another aregcmd command
304	Too few arguments
305	Too many arguments
306	Invalid argument
307	Object not found or path ambiguous; you have tried to set an unknown object or provided a partial name that matches multiple objects
308	Object already exists
309	Confirmation password did not match; when setting a user password, the re-entered password did not match the initial entry
310	Command failed; a generic response for a command that failed for a reason other than those listed here
311	Command is interactive; possibly due to attempting to batch mode with an interactive command
312	Validation failed; a new or modified object is not valid
313	Failed to reread; an error occurred while synchronizing changes from another aregcmd session; occurs only when using multiple aregcmd instances
314	Failed to open the pager; the PAGER environment variable is set to something that does not exist and the stats command is entered
315	Property is not modifiable; an administrator has attempted to modify a read-only property
316	Command failed: session is ViewOnly; an view-only administrator has attempted to modify a property

Table 2-5 *aregcmd Error Codes (continued)*

Error Code	Meaning
317	Command failed: server is a Replication Slave; an administrator has attempted to modify a replicated property on a slave of an SMDBR network
400	Login failed; an incorrect username or password was given during aregcmd log in
401	Unable to access server; aregcmd was unable to communicate with the radius process usually because the process is not running or is otherwise unresponsive
402	Login failed: version of aregcmd is incompatible with server; a new version of aregcmd has tried to connect with an older version of Cisco Prime AR
500	Internal error; a generic aregcmd error



CHAPTER 3

Using the Graphical User Interface

Cisco Prime Access Registrar (Cisco Prime AR) is a Remote Authentication Dial-In User Service (RADIUS) server that enables multiple dial-in Network Access Server (NAS) devices to share a common authentication, authorization, and accounting database.

This chapter describes how to use the standalone graphical user interface (GUI) of Cisco Prime AR to:

- Configure Cisco Prime Access Registrar
- Manage Network Resources managed by Cisco Prime AR
- Administer Cisco Prime AR related activities

The following topics help you to work with and understand the Cisco Prime AR GUI:

- [Launching the GUI](#)
- [Common Methodologies](#)
- [Dashboard](#)
- [Configuring Cisco Prime Access Registrar](#)
- [Network Resources](#)
- [Administration](#)
- [Read-Only GUI](#)

Launching the GUI

Cisco Prime AR requires you to use Microsoft Internet Explorer 8.0 SP1 (Windows 2000 and Windows XP). You start the GUI by pointing your browser to the Cisco Prime AR server and port 8080, as in the following:

```
http://ar_server_name:8080
```



Note

You can also use Mozilla Firefox 16.0 and Google Chrome 22.0 browsers to launch the Cisco Prime AR GUI.

To start a secure socket layer (SSL) connection, use **https** to connect to the Cisco Prime AR server and port 8443, as in the following:

```
https://ar_servr_name:8443
```

By default, both HTTP and HTTPS are enabled. The following sections describe how to disable HTTP and HTTPS:

- [Disabling HTTP](#)
- [Disabling HTTPS](#)

**Note**

For proper function of Cisco Prime AR GUI, the DNS name resolution for the server's hostname should be defined precisely.

Disabling HTTP

To disable HTTP access, you must edit the **server.xml** file in the **/cisco-ar/apache-tomcat-5.5.27/conf** directory. You must have root privileges to edit this file.

Use a text editor such as **vi** to open the **server.xml** file, and comment out lines 96-99. Use the **<!--** character sequence to begin a comment. Use the **-->** character sequence to end a comment.

The following are lines 93-99 of the **server.xml** file:

```
<!-- Define a non-SSL HTTP/1.1 Connector on port 8080 -->
  <!-- CHANGE MADE: Note: to disable HTTP, comment out this Connector -->
<Connector port="8080" maxHttpHeaderSize="8192"
    maxThreads="150 minSpare/Threads="25" maxSpareThreads="75"
    enableLookups="false" redirectPort="8443" acceptCount="100"
    connectionTimeout="20000" disableUploadTimeout="true" />
```

The following example shows these lines with beginning and ending comment sequences to disable HTTP:

```
<!-- Define a non-SSL HTTP/1.1 Connector on port 8080 -->
  <!-- CHANGE MADE: Note: to disable HTTP, comment out this Connector -->
<!--
<Connector className="org.apache.catalina.connector.http.HttpConnector"
    port="8080" minProcessors="5" maxProcessors="75"
    enableLookups="true" redirectPort="8443"
    acceptCount="10" debug="0" connectionTimeout="60000"/>
-->
```

After you modify the **server.xml** file, you must restart the Cisco Prime AR server for the changes to take effect. Use the following command line to restart the server:

```
/opt/CSCOAr/bin/arserver restart
```

Disabling HTTPS

To disable HTTPS access, you must edit the **server.xml** file in the **/cisco-ar/apache-tomcat-5.5.27/conf** directory. You must have root privileges to edit this file.

Use a text editor such as **vi** to open the **server.xml** file, and comment out lines 116-121. Use the **<!--** character sequence to begin a comment. Use the **-->** character sequence to end a comment.

The following are lines 111-121 of the **server.xml** file:

```
<!-- Define an SSL HTTP/1.1 Connector on port 8443 -->
  <!-- CHANGE MADE: enabled HTTPS.
```



```

    Note: to disable HTTPS, comment out this Connector -->
<Connector port="8443" maxHttpHeaderSize="8192"
    maxThreads="150" minSpareThreads="25" maxSpareThreads="75"
    enableLookups="true" disableUploadTimeout="true"
    acceptCount="100" scheme="https" secure="true"
    clientAuth="false"
    keystoreFile="/cisco-ar/certs/tomcat/server-cert.p12"
    keystorePass="cisco" keystoreType="PKCS12" sslProtocol="TLS" />
</Connector>

```

The following example shows these lines with beginning and ending comment sequences to disable HTTPS.

```

<!-- Define an SSL HTTP/1.1 Connector on port 8443 -->
<!-- CHANGE MADE: enabled HTTPS.
    Note: to disable HTTPS, comment out this Connector -->
<!--
<Connector className="org.apache.catalina.connector.http.HttpConnector"
    port="8443" minProcessors="5" maxProcessors="75"
    enableLookups="true"
    acceptCount="10" debug="0" scheme="https" secure="true">
    <Factory className="org.apache.catalina.net.SSLServerSocketFactory"
        keystoreFile="/cisco-ar/certs/tomcat/server-cert.p12"
        keystorePass="cisco" keystoreType="PKCS12"
        clientAuth="false" protocol="TLS" />
</Connector>
-->

```

After you modify the **server.xml** file, you must restart the Cisco Prime AR server for the changes to take effect. Use the following command line to restart the server:

```
/opt/CSCOar/bin/arserver restart
```

Login Page

The login page has fields for a username and password. This page displays when you first attempt to log in to the system, if a session times out, or after you log out of the system.

Logging In

Users who are configured as Administrators can log into the Cisco Prime AR server.

Logging in

To log into the Cisco Prime AR GUI:

-
- Step 1** Enter the relevant url in the browser. The Cisco Prime AR Login page is displayed.
 - Step 2** Enter the credentials in the provided fields.
 - Step 3** Click **Login**. The Cisco Prime AR main page is displayed.
-

**Note**

After installation of Cisco Prime AR server, when you log into the application for the first time, the application redirects to the change password page.

Refreshing the pages using the GUI

To stop the server (when it is running), and then immediately start the server, click the **Reload** link.

Restarting the GUI

To restart the Cisco Prime AR server, click the **Restart** link.

Applying different Themes for the GUI

To apply various themes for the Cisco Prime AR main page:

Step 1

Click the **Themes** link at the top right corner of the Cisco Prime AR main page.

Step 2

Choose a theme from the list that you want to apply for the main page. The selected theme will be applied for the Cisco Prime AR main page.

**Note**

If aregcmd interface is active, then it needs to be closed for restarting the Cisco Prime AR server.

Logging Out

To log out of the Cisco Prime AR GUI, click the **Logout** in the upper right portion of the Cisco Prime AR GUI window.

Common Methodologies

This section explains the operations that are common across the GUI interface of Cisco Prime AR. The functions explained in this section are referred throughout to this help system.

This section describes the following:

- [Filtering Records](#)
- [Deleting Records](#)
- [Setting Record Limits per Page](#)
- [Performing Common Navigations](#)
- [Relocating Records](#)

Filtering Records

To filter a record:

-
- Step 1** Navigate to the required page. For example, select **Configuration > Profile**. The Profile page is displayed.
 - Step 2** Enter the known details of the record in the **Filter** text box.
 - Step 3** Click **Go**. The matching records are displayed in the search criteria below.
 - Step 4** Click **Clear Filter** to clear the performed filter.
-

You can also perform the following:

- [Deleting Records](#)
- [Editing Records](#)
- [Setting Record Limits per Page](#)
- [Performing Common Navigations](#)
- [Relocating Records](#)

Editing Records

To edit the required records:

-
- Step 1** Navigate to the required page.
 - Step 2** Search for a record using the filter option, if required.
 - Step 3** Choose the required record that you want to edit.
 - Step 4** Click **Edit**. The selected record details are displayed in the appropriate page.
 - Step 5** Make the necessary changes.
 - Step 6** Click **Submit** or **Update** to save the details. The page is displayed with the updated details and a message is prompted. Otherwise click **Cancel** to return to the page without saving the details.
-

You can also perform the following:

- [Filtering Records](#)
- [Deleting Records](#)
- [Setting Record Limits per Page](#)
- [Performing Common Navigations](#)
- [Relocating Records](#)

Deleting Records

To delete a record:

-
- Step 1** Navigate to the required page. For example, choose **Configuration > Profile**. The Profile page is displayed.
 - Step 2** Search for a record using the filter option, if required.
 - Step 3** Choose the check box against the record that you want to delete.
 - Step 4** Click **Delete**. A message is displayed on successful deletion of the record.
-

You can also perform the following:

- [Filtering Records](#)
- [Editing Records](#)
- [Setting Record Limits per Page](#)
- [Performing Common Navigations](#)
- [Relocating Records](#)

Setting Record Limits per Page

To set the numbers of records to be displayed per page, select the record limit from the list available and click the **Go** button. The available denominations are **10, 25, 50, 100**, and **All**.





You can also perform the following:

- [Filtering Records](#)
- [Editing Records](#)
- [Deleting Records](#)
- [Performing Common Navigations](#)
- [Relocating Records](#)

Performing Common Navigations

On existence of more records that cannot be accommodated in a page, the records are displayed in multiple pages. [Table 3-1](#) describes the icons used for page navigation.

Table 3-1 Page Navigation Icons

Icons	Description
	To view the next page
	To return back to previous page
	To view the last page
	To return to the first page

You can also perform the following:

- [Filtering Records](#)
- [Editing Records](#)
- [Deleting Records](#)
- [Setting Record Limits per Page](#)
- [Relocating Records](#)

Relocating Records

Table 3-2 describes the icons used for relocating records.

Table 3-2 Icons for Relocating Records









Icons	Description
	To move a record from the Available List to the Selected List
	To move a record from the Selected List to the Available List
	To move all the records from the Available List to the Selected List
	To move all the records from the Selected List to the Available List
	To move the selected record one step above
	To move the selected record one step below

Table 3-2 *Icons for Relocating Records (continued)*

Icons	Description
	To move the selected record to the first position
	To move the selected record to the last position

You can also perform the following:

- [Filtering Records](#)
- [Editing Records](#)
- [Deleting Records](#)
- [Setting Record Limits per Page](#)
- [Performing Common Navigations](#)

Dashboard

The dashboard of the Cisco Prime AR GUI shows you the overview on the status on the server and user session details. It consists of the three tabs: **Server Status**, **User Sessions**, and **System Information**.

The **Server Status** provides the following details:

- AAA Server status— includes the AAA Process, Process ID, and Status.
- Health status of the AAA Server— the status of the AAA Server with respect to the performance condition is displayed.

The **User Sessions** consists of three graphs.

- Number of Sessions versus Duration in Weeks
- Number of Sessions versus Duration in Days

The Number of Sessions vs Duration in Weeks report provides the session details with respect to the number of weeks for which it is queried. The Number of Sessions vs Duration in Days report provides the session details with respect to the number of days for which it is queried. The Time(mins) vs Username report provides the accumulated time with respect to the selected username. This report can also be viewed in the form of chart and grid. Click the relevant icons below the graph to view the details in the respective formats.

The **System Information** tab consists of two graphs:

- Disk Availability for Cisco Prime AR Directory
- CPU Utilisation

The Disk Availability for Cisco Prime AR Directory report provides the details of the available disk space and used disk space in the Cisco Prime AR directory. When you hover the mouse on the pie chart, the details of the disk space are displayed. The CPU Utilisation report provides the utilization of the CPU for a specific time. The CPU usage is represented in kilobits per seconds.

Sessions

The Sessions feature of the dashboard helps you in viewing the records based on session id. [Table 3-3](#) lists and describes the various session views in the page.

Table 3-3 *Different Session Views*

Fields	Description
Release	To release the selected session details
Release All	To release all the records from the list
Send CoA	To send the CoA packet to the client device
SendPoD	To send the disconnect packet to the NAS to clear sessions and an Accounting-Stop notification to the client listed in the session record
Query All Sessions	To query all the sessions in the server

To view sessions details:

-
- Step 1** Choose **Dashboard > Sessions**. The Sessions page appears.
- Step 2** Choose the required session id to view **Release, Release All, Send CoA, Send PoD, and Query All Session** details. The session details are displayed as described in the above table.



Note You can locate the session id using the filter option. See [Filtering Records](#) for more details.

Configuring Cisco Prime Access Registrar

Cisco Prime AR's operation and configuration are based on a set of objects. On configuring the Cisco Prime AR major components, the server objects can be created. These objects include the following:

- [RADIUS](#)— the root of the configuration hierarchy
- [Profiles](#)—contains individual Profiles
- [UserGroups](#)—contains individual UserGroups
- [UserList](#)—contains individual UserLists which in turn contain users
- [Users](#)—contains individual authentication or authorization details of a user
- [Scripts](#)—contains individual Scripts
- [Clients](#)—contains individual Clients
- [Policies](#)—contains a set of rules applied to an Access-Request
- [Services](#)—contains individual Services

- **Replication**—maintains identical configurations on multiple machines simultaneously
- **RADIUS Dictionary**—passes information between a script and the RADIUS server, or between scripts running on a single packet
- **Vendor Dictionary**—allows to maintain the attributes of the vendor with respect to vendor id, vendor type and the attributes required to support the major NAS
- **Vendor Attributes**—communicates prepaid user balance information from the Cisco Prime AR server to the AAA client, and actual usage, either interim or total, between the NAS and the Cisco Prime AR server
- **Vendors**—contains individual Vendors
- **Translations**—adds new attributes to a packet or change an existing attribute from one value to another.
- **Translation Groups**—add translation groups for different user groups
- **Session Managers**—contains individual Session Managers
- **Resource Manager**—contains individual Resource Managers
- **Remote Servers**—contains individual Remote Servers
- **DIAMETER**—contains SessionManagement, Applications, and Commands
- **Advanced**—contains Ports, Interfaces, Reply Messages, and the Attribute dictionary
- **Rules**—allows to set rules for service selection

RADIUS

The **Radius** object is the root of the hierarchy. For each installation of the Cisco Prime AR server, there is one instance of the **Radius** object. You reach all other objects in the hierarchy from the **Radius**.

Table 3-4 lists and describes the fields in the Radius Properties page.



Note

Fields which are represented with the term “required” in the windows of the Cisco Prime AR GUI, denote mandatory input.

Table 3-4 *Radius Properties*

Fields	Description
Name	Required; must be unique in the list of servers in the cluster.
Version	Required; the currently installed version of Cisco Prime AR.
Description	Optional; description of the server.
DefaultSessionManager	Optional; Cisco Prime AR uses this property if none of the incoming scripts sets the environment dictionary variable Session-Manager .
IncomingScript	Optional; if there is a script, it is the first script Cisco Prime AR runs when it receives a request from any client and/or for any service.
OutgoingScript	Optional; if there is a script, it is the last script Cisco Prime AR runs before it sends a response to any client.

Table 3-4 *Radius Properties (continued)*

Fields	Description
DefaultAuthenticationService	Optional; Cisco Prime AR uses this property when none of the incoming scripts sets the environment dictionary variable Authentication-Service .
DefaultAuthorizationService	Optional; Cisco Prime AR uses this property when none of the incoming scripts sets the environment dictionary variable Authorization-Service .
DefaultAccountingService	Optional; Cisco Prime AR uses this property when none of the incoming scripts sets the environment dictionary variable Accounting-Service .
DefaultSessionService	Optional; Cisco Prime AR uses this property when none of the incoming scripts sets the environment dictionary variable Session-Service .

Setting Up or Changing the Radius Properties

To set or change the Radius properties:

-
- Step 1** Choose **Configuration > Radius**. The Radius Properties page appears.
 - Step 2** Specify the relevant details.
 - Step 3** Click **Save** to save the changes made to the Radius properties page.
- On successful setting up of the radius, a message is displayed.
-

Profiles

You use Profiles to group RADIUS attributes that belong together, such as attributes that are appropriate for a particular class of PPP or Telnet user. You can reference profiles by name from either the **UserGroup** or the **User** properties. Thus, if the specifications of a particular profile change, you can make the change in a single place and have it propagated throughout your user community.

Although you can use UserGroups or Profiles in a similar manner, choosing whether to use one rather than the other depends on your site. When you require some choice in determining how to authorize or authenticate a user session, then creating specific profiles, and creating a group that uses a script to choose among them is more flexible.

In such a situation, you might create a default group, and then write a script that selects the appropriate profile based on the specific request. The benefit to this technique is each user can have a single entry, and use the appropriate profile depending on the way they log in.

[Table 3-5](#) lists and describes the fields in the Add Profiles page.

Table 3-5 Profile Properties

Fields	Description
Name	Required; must be unique in the Profiles list.
Description	Optional; description of the profile.
RADIUS	Optional; set Radius, if the attribute and value needs to be defined for Radius.
VENDOR	Optional; set Vendor, if the attribute and value needs to be defined for Vendor.
Attribute Name	Optional; based on the Attribute Type selected, the attribute name is automated. Set the relevant name for the attribute type selected.
Value Attribute	Optional; set the value for the selected attribute. Click the Add button to save the details and list it in Radius and Value list. To navigate between the listed attributes, use the navigation option available adjacent to the list. See Relocating Records for more details. To delete the available attributes, select the relevant attribute and click the Delete button below.

Use the Profiles page for the following:

- [Filtering Records](#)
- [Adding Profile Details](#)
- [Editing Records](#)
- [Deleting Records](#)

Adding Profile Details

To add new profile details:

-
- Step 1** Choose **Configuration > Profiles**. The Profiles page is displayed.
 - Step 2** Click **Add**. The Add Profile page is displayed.
 - Step 3** Specify the required details.
 - Step 4** Click **Submit** to save the specified details in the Profiles page. Otherwise click **Cancel** to return to the Profiles page without saving the details. On successful creation of the profiles, the Profiles page is displayed else a respective error message is displayed.
-

UserGroups

The **UserGroups** objects allow you to maintain common authentication and authorization attributes in one location, and then have many users reference them. By having a central location for attributes, you can make modifications in one place instead of having to make individual changes throughout your user community.

For example, you can use several **UserGroups** to separate users by the services they use, such as a group specifying PPP and another for Telnet.

Table 3-6 lists and describes the fields in the Add User Groups page.

Table 3-6 *UserGroups Properties*

Fields	Description
General Properties tab	
Name	Required; must be unique in the UserGroup list.
Description	Optional; description of the group.
BaseProfile	Optional; when you set this to the name of a profile, Cisco Prime AR adds the properties in the Profile to the response dictionary as part of the authorization.
AuthenticationScript	Optional; when you set this property to the name of a script, you can use the Script to perform additional authentication checks to determine whether to accept or reject the user.
AuthorizationScript	Optional; when you set this property to the name of a script, you can use the script to add, delete, or modify the attributes of the Response dictionary.
Attribute List tab	
RADIUS	Optional; set Radius, if the attribute and value needs to be defined for Radius.
VENDOR	Optional; set Vendor, if the attribute and value needs to be defined for Vendor.
Attribute Name	Optional; based on the Attribute Type selected, the attribute name is automated. Set the relevant name for the attribute type selected.
Attribute Value	Optional; set the value for the selected attribute. Click the Add button to save the details and list it in Name and Value list. To navigate between the listed attributes, use the navigation option available adjacent to the list. See Relocating Records for more details. To delete the available attributes, select the relevant attribute and click the Delete button below.
CheckItems List tab	
RADIUS	Optional; set Radius, if the attribute and value needs to be defined for Radius.
VENDOR	Optional; set Vendor, if the attribute and value needs to be defined for Vendor.
Attribute Name	Optional; based on the Attribute Type selected, the attribute name is automated. Set the relevant name for the attribute type selected.
Attribute Value	Optional; set the value for the selected attribute. Click the Add button to save the details and list it in Check Name and Check Value list. To navigate between the listed attributes, use the navigation option available adjacent to the list. See Relocating Records for more details. To delete the available attributes, select the relevant attribute and click the Delete button below.

Use the User Groups page for the following:

- [Filtering Records](#)
- [Adding UserGroup Details](#)
- [Editing Records](#)
- [Deleting Records](#)

Adding UserGroup Details

To add new user groups details:

-
- Step 1** Choose **Configuration > UserGroups**. The User Groups page is displayed.
 - Step 2** Click **Add** to add new user group details. The Add UserGroup page is displayed.
 - Step 3** Specify the required details.
 - Step 4** Click **Submit** to save the specified details in the User Groups page. Otherwise click **Cancel** to return to the User Groups page without saving the details.

On successful creation of the user groups, the User Groups page is displayed else a respective error message is displayed.

UserList

The UserLists object contains all of the individual UserLists, which in turn, contain the specific users stored within Cisco Prime AR. Cisco Prime AR references each specific UserList by name from a Service whose type is set to local. When Cisco Prime AR receives a request, it directs it to a Service. When the Service has its type property set to local, the Service looks up the user's entry in the specific UserList and authenticates and/or authorizes the user against that entry.

You can have more than one UserList in the UserLists object. Therefore, use the UserLists object to divide your user community by organization. For example, you might have separate UserLists objects for Company A and B, or you might have separate UserLists objects for different departments within a company.

Using separate UserLists objects allows you to have the same name in different lists. For example, if your company has three people named Bob and they work in different departments, you could create a UserList for each department, and each Bob could use his own name. Using UserLists lets you avoid the problem of Bob1, Bob2, and so on.

If you have more than one UserList, Cisco Prime AR can run a script in response to requests. The script chooses the Service, and the Service specifies the actual UserList which contains the user. The alternative is dynamic properties.

[Table 3-7](#) lists and describes the fields in the Add User List page.

Table 3-7 User List Properties

Fields	Description
UserList Name	Required; must be unique.
Description	Optional; description of the user.

Use the User List page for the following:

- [Filtering Records](#)
- [Adding UserList Details](#)
- [Editing Records](#)
- [Deleting Records](#)

Adding UserList Details

To add new user list details:

-
- Step 1** Choose **Configuration** > **UserList**. The User List page is displayed.
- Step 2** Click **Add** to add new user list details. The Add UserList page is displayed.
- Step 3** Enter the required details.
- Step 4** Click **Submit** to save the specified details in the User List page. Otherwise click **Cancel** to return to the User List page without saving the details.

On successful creation of the user list, the User List page is displayed else a respective error message is displayed.



Note After adding a new user list, you can add users to the user list. See [Adding User Details](#) for more information.

Users

The user objects are created to hold the necessary details to authenticate or authorize a user. These users form the component of User Lists, where their details are stored within Cisco Prime AR. The users in local Userlist can have multiple profiles.



Note Usernames might not include the forward slash (/) character. If the Cisco Prime AR server receives an access request packet with a Username attribute containing a forward slash character and the Cisco Prime AR server uses an internal UserList to look up users, the server produces an error (AX_EINVAL) and might fail. If usernames require a forward slash, use a script to translate the slash to an acceptable, unused character.

Table 3-8 lists and describes the fields in the Add Users page.

Table 3-8 Users Properties

Fields	Description
General Properties tab	
Name	Required; must be unique.
Enabled	Required; must be checked to allow user access. If Enabled is not checked, user is denied access.
Allow Null Pwd	During authentication, if the Allow NULL Password environment variable is set to TRUE, user authentication is bypassed. By default, the Allow NULL Password environment variable is not set.
UserGroup	Use the drop-down list to select a UserGroup and use the properties specified in the UserGroup to authenticate and/or authorize the user. The default is none.
Password	Required; length must be between 0-253 characters.
Base Profile	Optional; use the drop-down list to select a Profile. If the service-type is not equal to Authenticate Only, Cisco Prime AR adds the properties in the Profile to the Response dictionary as part of the authorization. This field is optional for the CLI, but required for the GUI. Use the menu to select a profile other than the default None.
Confirm Password	Required; must match password.
User Defined	Optional; you can use this property to store notational information which you can then use to filter the UserList. This property also sets the environment variable for UserDefined.
Authentication Script	Optional; use the drop-down list to select the name of a script to perform additional authentication checks to determine whether to accept or reject the user. This field is optional for the CLI, but required for the GUI. Use the menu to select an Authentication Script other than the default None.
Authorization Script	Optional; use the drop-down list to select the name of a script to add, delete, or modify the attributes of the Response dictionary. This field is optional for the CLI, but required for the GUI. Use the menu to select an Authorization Script other than the default None.
Description	Optional; description of the user.
Attribute List tab	
RADIUS	Optional; set Radius, if the attribute and value needs to be defined for Radius.
VENDOR	Optional; set Vendor, if the attribute and value needs to be defined for Vendor.
Attribute Name	Optional; based on the Attribute Type selected, the attribute name is automated. Set the relevant name for the attribute type selected.
Attribute Value	Optional; set the value for the selected attribute. Click the Add button to save the details and list it in Name and Value list. To navigate between the listed attributes, use the navigation option available adjacent to the list. See Relocating Records for more details. To delete the available attributes, select the relevant attribute and click the Delete button below.

Table 3-8 Users Properties (continued)

Fields	Description
CheckItems List tab	
RADIUS	Optional; set Radius, if the attribute and value needs to be defined for Radius.
VENDOR	Optional; set Vendor, if the attribute and value needs to be defined for Vendor.
Attribute Name	Optional; based on the Attribute Type selected, the attribute name is automated. Set the relevant name for the attribute type selected.
Attribute Value	Optional; set the value for the selected attribute. Click the Add button to save the details and list it in Check Name and Check Value list. To navigate between the listed attributes, use the navigation option available adjacent to the list. See Relocating Records for more details. To delete the available attributes, select the relevant attribute and click the Delete button below.

Use the Users page for the following:

- [Filtering Records](#)
- [Adding User Details](#)
- [Editing Records](#)
- [Deleting Records](#)

Adding User Details

To add new user details:

-
- Step 1** Choose **Configuration > UserList**. The User List page is displayed.
 - Step 2** Click the user list name link. The Users page is displayed.
 - Step 3** Click **Add** to add new user details. The Add Users page is displayed.
 - Step 4** Specify the required details.
 - Step 5** Click **Submit** to save the specified details in the Users page. Otherwise click **Cancel** to return to the Users page without saving the details.

On successful creation of the user details, the Users page is displayed else a respective error message is displayed.

Scripts

The **Script** objects define the function Cisco Prime AR invokes whenever the **Script** is referenced by name from other objects in the configuration.

You can write three types of scripts:

- REX (RADIUS EXtension) scripts are written in C or C++, and thus are compiled functions that reside in shared libraries

- Tcl scripts are written in Tcl, and are interpreted functions defined in source files.
- Java scripts

For more information about scripts, see Chapter 12, “Using Extension Points.” of the *Cisco Prime Access Registrar 6.0 User Guide*.

Table 3-9 lists and describes the fields in the Add Scripts page.

Table 3-9 Script Object Properties

Fields	Description
Script Name	Required; must be unique in the Scripts list.
Language	Required; specify either REX, Tcl, or Java.
Description	Optional; description of the script.
File/Class Name	Required; specifies either a relative or absolute path. When you specify a relative path, the path must be relative to the \$INSTALL/scripts/radius/\$Language directory. When you specify an absolute path, the server must be able to reach it. For Java language scripts, the name of the class that implements the extension interface; the .class file should be placed in /cisco-ar/scripts/radius/java
Entry Point	Required; when not set, Cisco Prime AR uses the value specified in the Name property.
Init Entry Point	Optional; if set, it must be the name of the global symbol Cisco Prime AR should call when it initializes the shared library at system start up, and just before it unloads the shared library.
Init Entry Point Arg	Optional; when set, it provides the arguments to be passed to the InitEntryPoint in the environmental variable Arguments .

The **InitEntryPoint** properties allow you to perform initialization before processing and then cleanup before stopping the server. For example, when Cisco Prime AR unloads the script (when it stops the RADIUS server) it calls the **InitEntryPoint** again to allow it to perform any clean-up operations as a result of its initialization. One use of the function might be to allow the script to close an open Accounting log file before stopping the RADIUS server.



Note

When you use a Cisco Prime AR file service, Cisco Prime AR automatically closes any opened files. However, if you write scripts that manipulate files, you are responsible for closing them.



Note

If you have more than one extension point script (defined under **/Radius/Scripts**) using the same Java class, only one instance of the class is created and used for all the extension point scripts.

Use the Scripts page for the following:

- [Filtering Records](#)
- [Adding Script Details](#)
- [Editing Records](#)
- [Deleting Records](#)

Adding Script Details

To add new script details:

-
- Step 1** Choose **Configuration > Scripts**. The Scripts page is displayed.
 - Step 2** Click **Add** to add new scripts details. The Add Script page is displayed.
 - Step 3** Enter the required details.
 - Step 4** Click **Save** to save the specified details in the Scripts page. Otherwise click **Cancel** to return to the Scripts page without saving the details.
- On successful creation of the scripts, the Scripts page is displayed else a respective error message is displayed.
-

Policies

A Policy is a set of rules applied to an Access-Request.

[Table 3-10](#) lists and describes the fields in the Add Policies page.

Table 3-10 Policies Properties

Fields	Description
Name	Required; must be unique in the Policies list
Description	Optional; description of the Policy
Rules/Policies	Required; set the rules/policies to be grouped.
Operators	Required; set the operators to be grouped along with selected rules/policies. The selected rules and operators will be grouped and listed in the Grouping Box. To delete the available groups, select the relevant group from the Grouping list and click the Delete button below.

Use the Policies page for the following:

- [Filtering Records](#)
- [Adding Policy Details](#)
- [Editing Records](#)
- [Deleting Records](#)

Adding Policy Details

To add new policy details:

-
- Step 1** Choose **Configuration > Policies**. The Policies page is displayed.
 - Step 2** Click **Add** to add new policy details. The Add Policy page is displayed.

- Step 3** Specify the required details.
- Step 4** Click **Submit** to save the specified details in the Policies page. Otherwise click **Cancel** to return to the Policies page without saving the details.

On successful creation of the policies, the Policies page is displayed else a respective error message is displayed.

Services

Cisco Prime AR supports authentication, authorization, and accounting (AAA) services. In addition to the variety of built-in AAA services (specified in the **Type** property), Cisco Prime AR also enables you to add new AAA services through custom shared libraries.

This section lists the types of services available in Cisco Prime AR with their required and optional properties. The service you specify determines what additional information you must provide. The various types of services are:

- [Simple Services](#)
- [ServiceWithRS](#)
- [PEAP Service](#)
- [EAP Service](#)
- [Diameter Service](#)

Simple Services

Cisco Prime AR provides the following simple services:

- [Rex](#)
- [File](#)
- [Group](#)
- [Local](#)
- [Java](#)
- [WiMAX](#)
- [Radius Query](#)

Rex

Select rex service when a custom service needs to be created and a script for authentication, authorization, or accounting has to be used.

File

Select File type when local accounting is to be performed using a specific file. The files under the configuration will be saved in the configured name when the server is invoked even if the service is not being invoked by any request packets.

Cisco Prime AR flushes the accounting record to disk before it acknowledges the request packets. Based on the specified maximum file size and age, it closes the accounting file, moves it to a new name, and reopens the file as a new file. The file names are based on its creation and modification dates.

Group

A group service contains a list of references to other services and specifies whether the responses from each of the services should be handled as a logical AND or OR function, which is specified in the Result-Rule attribute of Group Services. The default value is AND.

When the Result-Rule attribute is set to AND or OR, each referenced service is accessed sequentially, and the Group Service waits for a response from the first referenced service before moving on to the next service (if necessary).

The ResultRule settings parallel-and and parallel-or are similar to the AND and OR settings except that they ask each referenced service to process the request simultaneously instead of asking each referenced server sequentially, thereby saving processing time.

Local

Select local services when authentication and authorization needs to be performed by Cisco Prime AR server using a specific UserList.

Java

Select Java service type when a custom service needs to be created and to use an extension point script to provide the service's functionality and handle both RADIUS and TACACS requests for authentication, authorization, or accounting.

WiMAX

Cisco Prime AR uses the Extensible Authentication Protocol (EAP) to enable the WiMAX feature. It captures the IP attributes and Mobility Keys that are generated during network access authentication.

Radius Query

Select this service type to query cached data through Radius Packets. It contains the list of session managers to be queried from and a list of (cached) attributes to be returned in the Access-Accept packet in response to a Radius Query request. It is initiated through an extension point script or through the Rule and Policy Engine by setting it to a new environment variable named Query-Service.

[Table 3-11](#) lists and describes the fields in the Add Simple Services List page. The fields listed below are the entire list of all the available types. The fields are displayed based on the type selected.

Table 3-11 Simple Service Properties

Fields	Description
Service Name	Required; must be unique in the Services list.
Incoming Script	Optional; name of script to run when the service starts.
Type	Required; must set it to a valid Cisco Prime AR service.
Outgoing Script	Name of script to run when the service ends.
Description	Optional; description of the service.

Table 3-11 Simple Service Properties (continued)

Fields	Description
Outage Script	Optional; if you set this property to the name of a script, Cisco Prime AR runs it when an outage occurs. This property allows you to create a script that notifies you when the RADIUS server detects a failure.
Outage Policy	Required; the default is RejectAll . This property defines how Cisco Prime AR handles requests if all servers listed in the RemoteServers properties are unavailable (that is, all remote RADIUS servers are not available). You must set it to one of the following: AcceptAll , DropPacket , or RejectAll .
Filename	Required; must be either a relative or an absolute path to the shared library containing the Service. When the pathname is relative, it must be relative to \$INSTALL/Scripts/Radius/rex .
EntryPoint	Required; must be set to the function's global symbol.
InitEntryPoint	Required; must be the name of the global symbol Cisco Prime AR should call when it initializes the shared library and just before it unloads the shared library. A rex service must have an InitEntryPoint even if the service only returns REX_OK.
InitEntryPointArgs	Optional; when set, it provides the arguments to be passed to the InitEntryPoint in the environmental variable Arguments .
FilenamePrefix	Required; a string that specifies where Cisco Prime AR writes the account records. It must be either a relative or absolute path. When you specify a relative path, it must be relative to the \$INSTALL/logs directory. When you specify an absolute path, the server must be able to reach it. The default is Accounting .
MaxFileAge	Optional; stored as a string, but is composed of two parts, a number and a units indicator (<n> <units>) in which the unit is one of: H, Hour, Hours, D, Day, Days, W, Week, Weeks. The default is one day.
RolloverSchedule	Indicates the exact time including the day of the month or day of the week, hour and minute to roll over the accounting log file.
MaxFileSize	Optional; stored as a string, but is composed of two parts, a number and a units indicator (<n> <units>) in which the unit is one of: K, kilobyte, or kilobytes, M, megabyte, or megabytes, or G, gigabyte, or gigabytes. The default is ten megabytes.
UseLocalTimeZone	When set to TRUE, indicates the accounting records' TimeStamp is in local time. When set to FALSE, the default, accounting records' TimeStamp is in GMT.
UserService	Required; name of service that can be used to authenticate
SessionManager	Required; select the required session manager from the available list.

Table 3-11 Simple Service Properties (continued)

Fields	Description
Result Rule	<p>When set to AND (the default), the response from the GroupService is positive if each of the services referenced return a positive result. The response is negative if any of the services reference return a negative result.</p> <p>When set to OR, the response from the GroupService is positive if any of the services referenced return a positive result. The response is negative if all the referenced services return a negative result.</p> <p>The settings parallel-AND or parallel-OR are similar to AND and OR settings, except that each referenced service processes requests simultaneously instead of asking each reference service sequentially to save processing time.</p>
InitEntryPoint	<p>Required; must be the name of the global symbol Cisco Prime AR should call when it initializes the shared library and just before it unloads the shared library.</p> <p>A rex service must have an InitEntryPoint even if the service only returns REX_OK.</p>
GroupServices	<p>Optional; use the GroupServices subdirectory to specify the subservices in an indexed list to provide specific ordering control of which services to apply first. Each subservice listed must be defined in the Services section of the Radius configuration and cannot be a of type group, eap-leap, or eap-md5.</p> <p>To navigate between the listed attributes, use the navigation option available adjacent to the list. See Relocating Records for more details.</p>
UserList	<p>Required; this object contains all of the individual UserLists, which in turn, contain the specific users stored within Cisco Prime AR. Cisco Prime AR references each specific UserList by name from a Service whose type is set to local.</p> <p>When Cisco Prime AR receives a request, it directs it to a Service. When the Service has its type property set to local, the Service looks up the user's entry in the specific UserList and authenticates and/or authorizes the user against that entry.</p>
Class name	Optional; set to the name of a class that implements the Extension interface.
InitializeArg	Optional; set to a string to be passed to the Initialize method if the class implements the optional ExtensionWithInitialization interface.
HARKKey	<p>Required; used as the base key to generate random HARKKey for all the HAs that are configured in Cisco Prime AR.</p> <p>By default, the value is <code>cisco112</code>. You can change this value.</p>
WimaxAuthenticationService	Required; a valid EAP service which can be used for WiMAX authentication. By default, this value is none.
HARKLifeTime	Required; used as time (in minutes) to regenerate the HARKKeys based on its lifetime.
WimaxSessionManager	Required; set a valid session manager which has HA and HA Cache as resource managers. By default, this value is none.

Table 3-11 Simple Service Properties (continued)

Fields	Description
WimaxQueryService	Required; set a valid RADIUS query service which is configured with WiMAX session manager. By default, this value is none.
WimaxPrepaidService	Optional; set a valid prepaid service to carry out the prepaid functionality of WiMAX. Otherwise this value is set to none.
AllowAAAToIncludeKeys	Optional; If this is set, the HAAA will include the hHA-RK-Key, hHA-RK-SPI and hHA-RK-Lifetime in the Access-Accept. Otherwise, those attributes will not be in the Access-Accept. By default this value is True.
RequiredMSK	Optional; If this is set, the MSK will be provided by the AAA server as a result of successful EAP-Authentication. By default, this value is False.
Attribute List tab	
Attribute type	Select either RADIUS or VENDOR . If Vendor is selected, specify the vendor type from the drop-down list. Select the attributes from the available list. To navigate between the listed attributes, use the navigation option available adjacent to the list. See Relocating Records for more details.
Session Manager tab	
Session Manager	Select the required session manager from the available list. To navigate between the listed attributes, use the navigation option available adjacent to the list. See Relocating Records for more details.

Use the Simple Services List page for the following:

- [Filtering Records](#)
- [Adding Simple Service Details](#)
- [Editing Records](#)
- [Deleting Records](#)

Adding Simple Service Details

To add new simple service details:

-
- Step 1** Choose **Configuration > Services > Simple**. The Services List(REX, FILE, LOCAL, GROUP, JAVA...) page is displayed.
 - Step 2** Click **Add** to add new simple service details. The Add Service page is displayed.
 - Step 3** Enter the required details.
 - Step 4** Click **Submit** to save the specified details in the Services List(REX, FILE, LOCAL, GROUP, JAVA...) page. Otherwise click **Cancel** to return to the Services List(REX, FILE, LOCAL, GROUP, JAVA...) page without saving the details.

On successful creation of the simple service properties, the Services List(REX, FILE, LOCAL, GROUP, JAVA...) page is displayed else a respective error message is displayed.

ServiceWithRS

The RemoteServers directory lists one or more remote servers to process access requests. The servers must also be listed in order under /Radius/RemoteServers. The order of the RemoteServers list determines the sequence for directing access requests when MultipleServersPolicy is set to RoundRobin mode. The first server in the list receives all access requests when MultipleServersPolicy is set to Failover mode.

The RemoteServers object can be used to specify the properties of the remote servers to which Services proxy requests. RemoteServers are referenced by name from the RemoteServers list in either the RADIUS, LDAP or TACACS-UDP Services.

[Table 3-12](#) lists and describes the fields in the Add ServiceWithRS List page.

Table 3-12 Remote Server Service Properties

Fields	Description
Service Name	Required; name of the remote server service
Incoming Script	Optional; name of script to run when the service starts
Type	Required; Remote service Type must be set to one of the following: domain-auth , ldap , ldap-accounting , odbc-accounting , odbc , oci-accounting , oci , prepaid , radius , or radius-session .
Outgoing Script	Optional; name of script to run when the service ends.
Outage Script	Optional; if you set this property to the name of a script, Cisco Prime AR runs it when an outage occurs. This property allows you to create a script that notifies you when the RADIUS server detects a failure.
Outage Policy	The default is RejectAll . This property defines how Cisco Prime AR handles requests if all servers listed in the RemoteServers properties are unavailable (that is, all remote RADIUS servers are not available). You must set it to one of the following: AcceptAll , DropPacket , or RejectAll .
Description (optional)	Optional; description of the remote server service
MultipleServers Policy	Required; must be set to either Failover or RoundRobin . When you set it to Failover , Cisco Prime AR directs requests to the first server in the list until it determines the server is offline. At which time, Cisco Prime AR redirects all requests to the next server in the list until it finds a server that is online. When you set it to RoundRobin , Cisco Prime AR directs each request to the next server in the RemoteServers list to share the resource load across all of the servers listed in the RemoteServers list.
RemoteServers	Select the required remote server from the available list. To navigate between the listed attributes, use the navigation option available adjacent to the list. See Relocating Records for more details.

Use the PEAP Services List page for the following:

- [Filtering Records](#)
- [Adding Remote Server Service Details](#)
- [Editing Records](#)

- [Deleting Records](#)

Adding Remote Server Service Details

To add new remote server service details:

-
- Step 1** Choose **Configuration > Services > ServiceWithRS**. The Services List (..with Remote Servers) page is displayed.
 - Step 2** Click **Add** to add new remote server service details. The Add ServiceWithRS page is displayed.
 - Step 3** Enter the required details.
 - Step 4** Click **Submit** to save the specified details in the Services List (..with Remote Servers) page. Otherwise, click **Cancel** to return to the Services List (..with Remote Servers) List page without saving the details.

On successful creation of the properties, the Services List (..with Remote Servers) page is displayed else a respective error message is displayed.

-

PEAP Service

Protected EAP (PEAP) is an authentication method designed to mitigate several weaknesses of EAP. PEAP leverages Industry standard authentication of the server using certificates TLS (RFC 2246) and creation of a secure session that can then be used to authenticate the client.

The PEAP protocol consists of two phases, an authentication handshake phase and a tunnel phase where another complete EAP authentication exchange takes place protected by the session keys negotiated by phase one. Cisco Prime AR supports the tunneling of other EAP methods within the PEAP phase two exchange.

Cisco Prime AR supports the two major existing variants of PEAP,

- [PEAP Version 0](#) (Microsoft PEAP)
- [PEAP Version 1](#) (Cisco Prime PEAP)

PEAP Version 0

PEAP Version 0 also called as Microsoft PEAP is described in IETF drafts (draft-kamath-pppext-peapv0-00.txt and draft-josefsson-pppext-eap-tls-eap-02.txt). This version of PEAP uses either EAP-MSChapV2 or EAP-SIM as an authentication method. The testing method used for this version of PEAP is radclient.

PEAP Version 1

PEAP Version 1 also called as Cisco Prime PEAP is described by IETF draft (draft-zhou-pppext-peapv1-00.txt). This version can use either EAP-GTC or EAP-SIM as an authentication method. The testing method used for this version of PEAP is radclient.

[Table 3-13](#) lists and describes the fields in the Add PEAP Services List page. The fields listed below are the entire list of all the available types. The fields are displayed based on the type selected.

Table 3-13 PEAP Service Properties

Fields	Description
Service Name	Required; service name
Incoming Script	Optional; script Cisco Prime AR server runs when it receives a request from a client.
Type	Required; must set it to a valid Cisco Prime AR service.
Outgoing Script	Optional; script Cisco Prime AR server runs before it sends a response to a client.
Maximum Message Size	Indicates the maximum length in bytes that a PEAP or EAP-TLS message can have before it is fragmented.
Server Certificate File	<p>Required; the full pathname of the file containing the server's certificate or certificate chain used during the TLS exchange. The pathname can be optionally prefixed with a special string that indicates the type of encoding used for the certificate. The two valid encoding prefixes are PEM and DER. If an encoding prefix is not present, the file is assumed to be in PEM format.</p> <p>The following example assumes that the subdirectory pki under /cisco-ar contains the server's certificate file. The file server-cert.pem is assumed to be in PEM format; note that the file extension .pem is not significant.</p> <p>set ServerCertificateFile PEM:/cisco-ar/pki/server-cert.pem</p>
Private Key Password	Required; the password used to protect the server's private key.
Server RSA Key File	Required; the full pathname of the file containing the server's RSA private key.
CRL Distribution URL	<p>Optional; The URL that Cisco Prime AR should use to retrieve the CRL. You can specify a URL that uses HTTP or LDAP.</p> <p>The following is an example for an HTTP URL: <http://crl.verisign.com/pca1.1.1.crl>.</p> <p>The following is an example for an LDAP URL: ldap://209.165.200.225:388/CN=development-CA,CN=acs-westcoast2,CN=CDP,CN=Public Key Services,CN=Services,CN=Configuration,DC=cisco,DC=com</p>
CA Certificate File	Optional; the full pathname of the file containing trusted CA certificates used for client verification. The file can contain more than one certificate, but all certificates must be in PEM format. DER encoding is not allowed.
Certificate Verification Mode	<p>Optional; specifies the type of verification used for client certificates. Must be set to one of RequireCertificate, None, or Optional.</p> <ul style="list-style-type: none"> RequireCertificate causes the server to request a client certificate and authentication fails if the client refuses to provide one. None will not request a client certificate. <p>Optional causes the server to request a client certificate but the client is allowed to refuse to provide one.</p>

Table 3-13 PEAP Service Properties (continued)

Fields	Description
CA Certificate Path	<p>Optional; the name of a directory containing trusted CA certificates (in PEM format) used for client verification. This parameter is optional, and if it is used there are some special preparations required for the directory it references.</p> <p>Each certificate file in this directory must contain exactly one certificate in PEM format. The server looks up the certificate files using the MD5 hash value of the certificate's subject name as a key. The directory must therefore also contain a set of symbolic links each of which points to an actual certificate file. The name of each symbolic link is the hash of the subject name of the certificate.</p> <p>For example, if a certificate file name ca-cert.pem is located in the CACertificatePath directory, and the MD5 hash of the subject name contained in ca-cert.path.pem is 1b96dd93, then a symbolic link named 1b96dd93 must point to the ca-cert.pem file.</p> <p>If there are subject name collisions such as multiple certificates with the same subject name, each link name must be indexed with a numeric extension as in 1b96dd93.0 and 1b96dd93.1.</p>
Verification Depth	Optional; specifies the maximum length of the certificate chain used for client verification.
Enable Session Cache	Optional; specifies whether TLS session caching (fast reconnect) is enabled or not. Set to True to enable session caching; otherwise set to False.
Tunnel Service	Required; must be the name of an existing EAP-MSCHAPv2 or EAP-SIM service.
Authentication Timeout	Required; specifies time (in seconds) to wait before an authentication request times out; defaults to 120.
Description (optional)	Optional; description of the PEAP service.
Session Timeout	<p>Optional; if TLS session caching (fast reconnect) is enabled, SessionTimeout specifies the maximum lifetime of a TLS session. Expired sessions are removed from the cache and will require a subsequent full authentication.</p> <p>SessionTimeout is specified as a string consisting of pairs of numbers and units, where units might be one of the following: M, Minute, Minutes, H, Hour, Hours, D, Day, Days, W, Week, Weeks, as in the following:</p> <p>Set SessionTimeout "1 Hour 45 Minutes"</p>
Enable WPS	Optional; When set to TRUE, enables Windows Provisioning Service (WPS) and provides two other properties, MasterURL and WPSGuestUserProfile. The default value is FALSE.
Master URL	Optional; when using WPS, specifies the URL of the provisioning server which is modified with the appropriate fragment and sent to the client.
WPS Guest User Profile	<p>Optional; when using WPS, specifies a profile to be used as a guest user profile; must be a valid profile under /Radius/Profiles.</p> <p>This profile is used for guests and users whose account has expired. This profile normally contains attributes denoting the VLAN-id of the guest network (which has the provisioning server alone) and might contain IP-Filters that would restrict the access of the guest (to only the provisioning server).</p>

Use the ServiceWithRS List page for the following:

- [Filtering Records](#)
- [Adding PEAP Service Details](#)
- [Editing Records](#)
- [Deleting Records](#)

Adding PEAP Service Details

To add new PEAP service details:

-
- Step 1** Choose **Configuration > Services > PEAP**. The PEAP Services List page is displayed.
- Step 2** Click **Add** to add new PEAP service details. The Add PEAP-Service page is displayed.
- Step 3** Specify the relevant PEAP service details.
- Step 4** Click **Submit** to save the specified details in the PEAP Services List page. Otherwise click **Cancel** to return to the PEAP Services List page without saving the details.
- On successful creation of the PEAP service properties, the PEAP Services List page is displayed else a respective error message is displayed.
-

EAP Service

Cisco Prime Access Registrar (Cisco Prime AR) supports the Extensible Authentication Protocol (EAP) to provide a common protocol for differing authentication mechanisms. It provides dynamic selection of the authentication mechanism at the time of authentication based on information transmitted in the Access-Request.

Cisco Prime AR supports the following EAP authentication methods:

- [EAP-AKA](#)
- [EAP-FAST](#)
- [EAP-GTC](#)
- [EAP-LEAP](#)
- [EAP-MD5](#)
- [EAP-Negotiate](#)
- [EAP-MSChapV2](#)
- [EAP-SIM](#)
- [EAP-Transport Level Security \(TLS\)](#)
- [EAP-TTLS](#)

EAP-AKA

Authentication and Key Agreement (AKA) is an EAP mechanism for authentication and session key distribution. It is used in the 3rd generation mobile networks Universal Mobile Telecommunications System (UMTS) and CDMA2000. AKA is based on symmetric keys, and typically runs in a UMTS Subscriber Identity Module (USIM), or a (Removable) User Identity Module ((R) UIM), similar to a smart card. EAP-AKA (Extensible Authentication Protocol Method for UMTS Authentication and Key Agreement) includes optional identity privacy support, optional result indications, and an optional fast reauthentication procedure. The EAP-AKA authentication service is extended to generate a Diameter message Multimedia-Authentication-Request (MAR), with the subscriber identity(IMSI), to the Home Subscriber Server (HSS) when it requires the authentication vectors. The HSS sends a Diameter Multimedia-Authentication-Answer (MAA) back containing the number of quintuplets.

EAP-FAST

EAP-FAST is an authentication method which uses the EAP-MSChapV2 method for credential provisioning and EAP-GTC for authentication. Credential provisioning typically occurs only during the client's initial EAP-FAST authentication. Subsequent authentications rely on the provisioned credential and will usually omit the provisioning step.

This authentication protocol is designed to address the performance shortcomings of prior TLS-based EAP methods while retaining features such as identity privacy and support for password-based protocols. The EAP-FAST protocol is described by the IETF draft (draft-cam-winget-eap-fast-00.txt).

EAP-GTC

This method defined in RFC 2284, is used for transmitting a username and password to an authentication server.

**Note**

It should not be used except as an authentication method for PEAP Version 1 because the password is not protected.

EAP-LEAP

The new AAA Cisco-proprietary protocol called Light Extensible Authentication Protocol (LEAP) supported by Cisco Prime AR, is a proprietary Cisco authentication protocol designed for use in IEEE 802.11 wireless local area network (WLAN) environments. Important features of LEAP include:

- Mutual authentication between the network infrastructure and the user
- Secure derivation of random, user-specific cryptographic session keys
- Compatibility with existing and widespread network authentication mechanisms (e.g., RADIUS)

**Note**

Cisco Prime AR supports a subset of EAP to support LEAP. This is not a general implementation of EAP for Cisco Prime AR.

The Cisco-Wireless or LEAP is an EAP authentication mechanism where the user password is hashed based on an MD4 algorithm.

EAP-MD5

This is another EAP authentication exchange. In EAP-MD5 there is a CHAP-like exchange and the password is hashed by a challenge from both client and server to verify the password. On successful verification, the connection proceeds, although the connection is periodically rechallenge (per RFC 1994).

EAP-Negotiate

This is a special service used to select at runtime the EAP service to be used to authenticate the client. It is configured with a list of candidate EAP services that represent the allowable authentication methods in preference order.

EAP-Negotiate is useful when the client population has deployed a mix of different EAP methods that must be simultaneously supported by Cisco Prime AR. EAP-Negotiate solves the problem of distinguishing client requirement by using the method negotiation feature of the EAP protocol.

EAP-MSChapV2

EAP-MSChapv2 encapsulates the MSChapV2 protocol (specified by RFC 2759) and can be used either as an independent authentication mechanism or as an inner method for PEAP Version 0 (recommended). This is based on draft-kamath-pppext-eap-mschapv2-00.txt, an informational IETF draft document.

EAP-SIM

An access point uses the Cisco Prime AR RADIUS server to perform EAP-SIM authentication of mobile clients. Cisco Prime AR must obtain authentication information from the HLR. Cisco Prime AR contacts the MAP gateway that performs the MAP protocol over SS7 to the HLR. The EAP-SIM authentication service is extended to generate a Diameter message Multimedia-Authentication-Request (MAR), with the subscriber identity (IMSI), to the HSS when it requires the authentication vectors. The HSS sends a Diameter Mutlimedia-Authentication-Answer (MAA) back containing the number of triplets.

EAP-Transport Level Security (EAP-TLS)

This is an authentication method (described in RFC 2716) which leverages TLS, described in RFC 2246, to achieve certificate-based authentication of the server and the client (optionally). It provides many of the same benefits as PEAP but differs in the lack of support for legacy authentication methods.

EAP-Transport Level Security (TLS)

This is an authentication method (described in RFC 2716) which leverages TLS, described in RFC 2246, to achieve certificate-based authentication of the server and the client (optionally). It provides many of the same benefits as PEAP but differs in the lack of support for legacy authentication methods.

EAP-TTLS

The Extensible Authentication Protocol Tunneled TLS (EAP-TTLS) is an EAP protocol that extends EAP-TLS. EAP- TTLS extends the authentication negotiation EAP-TLS by using the secure connection established by the TLS handshake to exchange additional information between client and server. It leverages TLS (RFC 2246) to achieve certificate-based authentication of the server (and optionally the client) and creation of a secure session that can then be used to authenticate the client using a legacy mechanism.

EAP-TTLS is a two-phase protocol. Phase 1 conducts a complete TLS session and derives the session keys used in Phase 2 to securely tunnel attributes between the server and the client. The attributes tunneled during Phase 2 can be used to perform additional authentication(s) via a number of different mechanisms.

The authentication mechanisms used during Phase 2 include PAP, CHAP, MS-CHAP, MS-CHAPv2, and EAP. If the mechanism is EAP, then several different EAP methods are possible.

[Table 3-14](#) lists and describes the fields in the Add EAP Services List page. The fields listed below are the entire list of all the available types. The fields are displayed based on the type selected.

Table 3-14 EAP Service Properties

Fields	Description
Service Name	Required; service name
Incoming Script	Optional script Cisco Prime AR server runs when it receives a request from a client.
Type	Required; must set it to a valid Cisco Prime AR service
Outgoing Script	Optional script Cisco Prime AR server runs before it sends a response to a client
Description (optional)	Optional; description of the PEAP service.
Authentication Timeout	Mandatory; specifies time (in seconds) to wait before an authentication request times out; defaults to 120.
UserService	Required; name of service that can be used to authenticate using cleartext passwords.
ServiceList	List of preconfigured EAP authentication services. To navigate between the listed attributes, use the navigation option available adjacent to the list. See Relocating Records for more details.
Maximum Message Size	Required; indicates the maximum length in bytes that a PEAP message can have before it is fragmented.
Server Certificate File	Required; the full pathname of the file containing the server's certificate or certificate chain used during the TLS exchange. The pathname can be optionally prefixed with a special string that indicates the type of encoding used for the certificate. The two valid encoding prefixes are PEM and DER. If an encoding prefix is not present, the file is assumed to be in PEM format.
Private Key Password	Required; the password used to protect the server's private key.
Server RSA Key File	<p>Required; the full pathname of the file containing the server's RSA private key. The pathname can be optionally prefixed with a special string that indicates the type of encoding used for the certificate. The two valid encoding prefixes are "PEM" and "DER". If an encoding prefix is not present, the file is assumed to be in PEM format.</p> <p>The following example assumes that the subdirectory pki under /cisco-ar contains the server's certificate file. The file server-key.pem is assumed to be in PEM format. The file extension .pem is not significant.</p> <p>set ServerRSAKeyFile PEM:/cisco-ar/pki/server-key.pem</p>
CRL Distribution URL	<p>Optional; enter the URL that Cisco Prime AR should use to retrieve the CRL. You can specify a URL that uses HTTP or LDAP.</p> <p>The following is an example for an HTTP URL: <http://crl.verisign.com/pca1.1.1.crl>.</p> <p>The following is an example for an LDAP URL: ldap://209.165.200.225:388/CN=development-CA,CN=acs-west-coast2,CN=CDP,CN=Public Key Services,CN=Services,CN=Configuration,DC=cisco,DC=com</p>

Table 3-14 EAP Service Properties (continued)

Fields	Description
CA Certificate File	Optional; the full pathname of the file containing trusted CA certificates used for client verification. The file can contain more than one certificate, but all certificates must be in PEM format. DER encoding is not allowed.
Certificate Verification Mode	The value is set to optional by default. If set to RequireCertificate, the client certificate will always be verified. If set to optional, client certificate verification happens optionally.
CA Certificate Path	<p>The name of a directory containing trusted CA certificates (in PEM format) used for client verification. This parameter is optional and if it is used there are some special preparations required for the directory it references.</p> <p>Each certificate file in this directory must contain exactly one certificate in PEM format. The server looks up the certificate files using the MD5 hash value of the certificate's subject name as a key. The directory must therefore also contain a set of symbolic links each of which points to an actual certificate file. The name of each symbolic link is the hash of the subject name of the certificate.</p> <p>For example, if a certificate file named ca-cert.pem is located in the CACertificatePath directory, and the MD5 hash of the subject name contained in ca-cert.path.pem is 1b96dd93, then a symbolic link named 1b96dd93 must point to ca-cert.pem.</p> <p>If there are subject name collisions such as multiple certificates with the same subject name, each link name must be indexed with a numeric extension as in 1b96dd93.0 and 1b96dd93.1.</p>
Verification Depth	Optional; specifies the maximum length of the certificate chain used for client verification.
Enable Session Cache	Optional; specifies whether TLS session caching (fast reconnect) is enabled or not. Set to True to enable session caching; otherwise set to False.
Session Timeout	<p>Required; if TLS session caching (fast reconnect) is enabled, SessionTimeout specifies the maximum lifetime of a TLS session. Expired sessions are removed from the cache and will require a subsequent full authentication.</p> <p>SessionTimeout is specified as a string consisting of pairs of numbers and units, where units might be one of the following: M, Minute, Minutes, H, Hour, Hours, D, Day, Days, W, Week, Weeks, as in the following:</p> <p>Set SessionTimeout "1 Hour 45 Minutes"</p>

Table 3-14 EAP Service Properties (continued)

Fields	Description
UseECCCertificate	Determines the applicability of the authentication mechanism in SmartGrid Solutions. When you select this check box, it can use the ECC, RSA, or combination of both certificate for certificate based verification. When you uncheck this check box, it can only use the RSA certificate for certificate based verification. The default location to fetch the certificate file is /cisco-ar/pki .
Authentication Service	Specifies the name of the EAP-GTC service used for authentication. The named service must have the UseLabels parameter set to True.
User Prompt	Optional string the client might display to the user; default is Enter password:” Use the set command to change the prompt, as in the following: set UserPrompt “Admin Password:”
UseLabels	Required; must be set to TRUE for EAP-FAST authentication and set to FALSE for PEAP authentication. Set to FALSE by default.
SystemID	Optional; string that identifies the sender of the MSChapV2 challenge message.
IsWindows7Client	Optional; must be set to TRUE for EAP-MSChapV2 authentication. Set to FALSE by default.
Authority Identifier	Required; a string that uniquely identifies the credential (PAC) issuer. The client uses this value to select the correct PAC to use with a particular server from the set of PACs it might have stored locally.
Authority Information	Required; a string that provides a descriptive text for this credential issuer. The value can be displayed to the client for identification purposes and might contain the enterprise or server names.
Credential Life Time	Optional; specifies the maximum lifetime of a Protected Access Credential (PAC). Clients that successfully authenticate with an expired PAC will be reprovisioned with a new PAC. CredentialLifetime is specified as a string consisting of pairs of numbers and units, where units might be one of the following: M, Minute, Minutes, H, Hour, Hours, D, Day, Days, W, Week, Weeks. Credentials that never expire should be specified as Forever.
Provision Service	Required; specifies the name of the EAP-MSChapV2 service used for provisioning.
Provision Mode	Required; specifies the TLS mode used for provisioning. Clients only support the default Anonymous mode.
Always Authenticate	Optional; indicates whether provisioning should always automatically rollover into authentication without relying on a separate session. Most environments, particularly wireless, will perform better when this parameter is set to True, the default value.

Table 3-14 EAP Service Properties (continued)

Fields	Description
SubscriberDBLookup	Specifies the type of communication with the HLR/HSS server. Based on the type selected, the communication happens with the HLR/HSS server using the diameter Wx interface, MAP protocol, or SIGTRAN-M3UA protocol. This field is displayed when you select the eap-sim option in the Type field.
Subscriber_DBLookup	Specifies the type of communication with the HLR/HSS server. Based on the type selected, the communication happens with the HLR/HSS server using the diameter Wx interface, SIGTRAN protocol, or SIGTRAN-M3UA protocol. This field is displayed when you select the eap-aka option in the Type field.
DestinationRealm	Required. Need to configure the Diameter Remote Server for the Realm. The role of the remote server should be Relay.
PreRequestTranslationScript	Optional. Cisco Prime AR server runs before sending the request to the Diameter remote server. The script can modify the Radius packet dictionaries.
PostRequestTranslationScript	Optional. Cisco Prime AR server runs before sending the request to the Diameter remote server. The script can modify the Diameter packet dictionaries.
PreResponseTranslationScript	Optional. Cisco Prime AR server runs after receiving the response from the Diameter remote server. The script can modify the Diameter packet dictionaries.
PostResponseTranslationScript	Optional. Cisco Prime AR server runs after receiving the response from the Diameter remote server. The script can modify the Radius packet dictionaries.
FetchAuthorizationInfo	When you select this check box, it fetches MSISDN from HLR.
General tab	
The details in the tab is displayed based on the eap-sim or eap-aka option you select in the Type field.	
MultipleServersPolicy	Required. Must be set to either Failover or RoundRobin. When set to Failover, Cisco Prime AR directs requests to the first server in the list until it determines the server is offline. At that time, Cisco Prime AR redirects all requests to the next server in the list until it finds a server that is online. When set to RoundRobin, Cisco Prime AR directs each request to the next server in the RemoteServers list to share the resource load across all of the servers listed in the RemoteServers list.
NumberOfTriplets	Required; number of triplets (1, 2, or 3) to use for authentication; default is 2.

Table 3-14 EAP Service Properties (continued)

Fields	Description
PseudonymSecret	<p>Required; the secret string that is used as the basis for protecting identities when identity privacy is enabled. This should be at least 16 characters long and have a value that is impossible for an outsider to guess. The default value is secret.</p> <p>Note It is very important to change PseudonymSecret from its default value to a more secure value when identity privacy is enabled for the first time.</p>
PseudonymRenewtime	<p>Required; specifies the maximum age a pseudonym can have before it is renewed. When the server receives a valid pseudonym that is older than this, it generates a new pseudonym for that subscriber. The value is specified as a string consisting of pairs of numbers and units, where the units might be of the following: M, Minute, Minutes, H, Hour, Hours, D, Day, Days, W, Week, Weeks. The default value is “24 Hours”.</p> <p>Examples are: “8 Hours”, “10 Hours 30 Minutes”, “5 D 6 H 10 M”</p>
PseudonymLifetime	<p>Required; specifies the maximum age a pseudonym can have before it is rejected by the server, forcing the subscriber to authenticate using its permanent identity. The value is specified as a string consisting of pairs of numbers and units, where the units might be one of the following: M, Minute, Minutes, H, Hour, Hours, D, Day, Days, W, Week, Weeks. It can also be Forever, in which case, pseudonyms do not have a maximum age. The default value is “Forever”.</p> <p>Examples are: “Forever”, “3 Days 12 Hours 15 Minutes”, “52 Weeks”</p>
ReauthenticationTimeout	<p>Required; specifies the time in seconds that reauthentication identities are cached by the server. Subscribers that attempt to reauthenticate using identities that are older than this value will be forced to use full authentication instead. The default value is 3600 (one hour).</p>
EnableReauthentication	<p>Optional; when True, the fast reauthentication option is enabled. The default value is False.</p>
UseProtectedResults	<p>Optional; enables or disables the use of protected results messages. Results messages indicate the state of the authentication but are cryptographically protected.</p>
ReauthenticationRealm	<p>Optional; this information will be supplied later.</p>
MaximumReauthentications	<p>Required; specifies the maximum number of times a reauthentication identity might be reused before it must be renewed. The default value is 16.</p>
TripletCacheTimeout	<p>Required; time in seconds an entry remains in the triplet cache. A zero (0) indicates that triplets are not cached. The maximum is 28 days; the default is 0 (no caching).</p>
Authentication Timeout	<p>Required; time in seconds to wait for authentication to complete. The default is 2 minutes; range is 10 seconds to 10 minutes.</p>

Table 3-14 EAP Service Properties (continued)

Fields	Description
UseSimDemoTriplets	Optional; set to TRUE to enable the use of demo triplets. This must be disabled for release builds.
AlwaysRequestIdentity	Optional; when True, enables the server to obtain the subscriber's identity via EAP/SIM messages instead of relying on the EAP messages alone. This might be useful in cases where intermediate software layers can modify the identity field of the EAP-Response/Identity message. The default value is False.
EnableIdentityPrivacy	Optional; when True, the identity privacy feature is enabled. The default value is False.
Generate3GPPCompliantPseudonym	Optional; the value is set to False by default. If set to TRUE then Cisco Prime AR generates a 12 octet 3GPP compliant pseudonym identity. The Pseudonym username identities are used to protect the privacy of subscriber identities.
SendReAuthIDInAccept	Optional; the value is set to False by default. When set to True, Cisco Prime AR sends SN-Fast-ReAuth-UserName (Starent VSA) in access-accept message.
Outage Script	Optional; if you set this property to the name of a script, Cisco Prime AR runs it when an outage occurs. This property allows you to create a script that notifies you when the RADIUS server detects a failure.
Remote Servers tab	
Attribute	Optional; list of remote RADIUS servers which are map gateways. The remote server type must be set to map-gateway. To navigate between the listed attributes, use the navigation option available adjacent to the list. See Relocating Records for more details.

Use the EAP Services List page for the following:

- [Filtering Records](#)
- [Adding EAP Service Details](#)
- [Editing Records](#)
- [Deleting Records](#)

Adding EAP Service Details

To add new EAP service details:

-
- Step 1** Choose **Configuration > Services > EAP**. The EAP Services List page is displayed.
 - Step 2** Click **Add** to add new EAP service details. The Add EAP-Service page is displayed.
 - Step 3** Enter the relevant details.
 - Step 4** Click **Submit** to save the specified details in the EAP Services List page. Otherwise click **Cancel** to return to the EAP Services List page without saving the details.

On successful creation of the EAP Service properties, the EAP Services List page is displayed else a respective error message is displayed.

Diameter Service

Proxy agents assist in routing Diameter messages using the Diameter routing table. Diameter proxy service works in tandem with the rule policy engine to perform the routing for multiple realms or applications. The following are the multiple peer policies supported by the proxy service:

- RoundRobin
- FailOver
- IMSI Range Based.

[Table 3-15](#) lists and describes the fields in the Add Diameter Services List page. The fields listed below are the entire list of all the available roles. The fields are displayed based on the role selected.

Table 3-15 *Diameter Service Properties*

Fields	Description
Name	Required; name of the Diameter server.
Realm	Required; realm of the route. Must be unique for a route table.
Incoming Script	Optional; enabled when role is set to Proxy or Local. When set, must be the name of a known incoming script. Cisco Prime AR runs the IncomingScript before proxying the diameter packet to the remote diameter server.
Outgoing Script	Optional; enabled when role is set to Proxy or Local. When set, must be the name of a known outgoing script. Cisco Prime AR runs the OutgoingScript after it receives the response from the remote Diameter server.
Authentication Service	Required; used when service is configured to process the diameter requests locally. Set to valid service of type (local/ldap/odbc) to authenticate the user. This field is displayed when you select the role type as 'Local' in the Role field.
AccountingService	Required; used when service is configured to process the accounting requests locally. Set to valid accounting service of type(file/odbc-accounting) to write the accounting records. This field is displayed when you select the role type as 'Local' in the Role field.
Description	Optional; description of the Diameter server.

Table 3-15 *Diameter Service Properties (continued)*

Fields	Description
Role	<p>Required; specifies the role that the diameter entity will play in resolving messages matching the realm.</p> <p>The role can be any one of the following:</p> <p>Relay - Application acting as a Relay Agent.</p> <p>Redirect - Application acting as a Redirect Agent.</p> <p>Proxy - Application acting as a Proxy Agent. When the role is set to Proxy, the IncomingScript and OutgoingScript points are enabled.</p> <p>Local - Application processes the requests locally. When the role is set to Local, the AuthenticationService and AccountingService are enabled.</p> <p>By default, the Proxy option is selected. However, you can select another option from the drop-down list.</p>
Type	Required; specifies the service type. The service type 'Diameter' is automatically displayed in this field.

PEER Statements

This is displayed when you select the 'Local', 'Relay', or 'Redirect' option in the Role field.

Name	Required; name of the peer.
Host Name	Required; the hostname or IP address of the peer. The hostname must exist in the client list for the route to be active.
Metric	Required; metric value for the peer entry. The higher the value the lower the preference. The highest value of preference is 0.
VendorSpecific	Required; the default is FALSE. If set to FALSE, the application is ordinary application and user is prompted to enter the ApplicationID. If set to TRUE, the application is a VendorSpecific Application. User is prompted to enter VendorSpecificApplicationID and VendorID.
VendorID	<p>Required; specifies the VendorID for the application.</p> <p>Example:</p> <pre>DIAMETER 3GPP Cx APPLICATION VendorSpecificApplicationID 16777216 VendorID 10415</pre>
VendorSpecificApplicationID	Required; specifies the integer value for the vendor specific application.
ApplicationID	Required; application used in the route. The application Id should be available in /Advanced/Diameter/Applications.

Applications

This is displayed when you select the 'Proxy' option in the Role field.

Name	Required; name of the application.
Description	The description of the application.

Table 3-15 *Diameter Service Properties (continued)*

Fields	Description
ApplicationID	Required; specifies the unique integer value for the application. It represents the application id of the Application used for load balancing the diameter messages.
EnableSticky	Required; default is FALSE. If set to True, the sticky entries for load balancing is enabled and the user is prompted to enter the values for StickySessionKey, StickyCreationCmdList, and StickyDeletionCmdList.
MultiplePeersPolicy	Required; must be set to RoundRobin, FailOver, or IMSIRangeBased. Policy used by the Cisco Prime AR server to load balance the peers.
StickySessionKey	Required; used as the sticky key for mapping the sticky sessions. Set the value to a valid AVP in order to use the sticky key for maintaining diameter sessions. This ensures that Cisco Prime AR maps the request to the same server for all the subsequent messages using the sticky key. For example, set StickyAVP "Session-Id". When the Cisco Prime AR server receives the CCR-I request, Cisco Prime AR extracts the Session-Id from the request packet, maps the Session to the peer configured in the list, and forwards the request to the chosen peer. Cisco Prime AR chooses the same peer for all the subsequent messages(CCR-Update/CCR-Terminate) with same Session-Id.
StickyCreationCmdList	Required; specifies the command list to create the sticky entries. Specify the list of ' ' separated command code, AVP name, and its value to create the sticky sessions. The following is the StickyCreationCmdList format: <commandcode1>::<AVPName1=Value1> <commandcode2<::<AVPName2=Value2> <commandcode3> For example, if the sticky session entries need to created based on command code '265' or based on command code '271' with Accounting-Record-Type value as 2, use the format below: Set StickyCreationCmdList "265 271:: Accounting-Record-Type=2"
StickyDeletionCmdList	Required; specifies the command list to delete the sticky entries. Specify the list of ' ' separated command code, AVP name, and its value to delete the sticky sessions. The following is the StickyDeletionCmdList format: <commandcode1>::<AVPName1=Value1> <commandcode2<::<AVPName2=Value2> <commandcode3> For example, if the sticky session entries need to deleted based on command code '271' with Accounting-Record-Type value as 4, use the format below: Set StickyDeletionCmdList "271:: Accounting-Record-Type=4"
PEER Definitions Proxy	
Name	Required; name of the peer.

Table 3-15 *Diameter Service Properties (continued)*

Fields	Description
Host Name	Required; hostname or IP address of the peer. The HostName must exist in the client list for the route to be active.
Metric	Required; metric value for this peer entry. The higher the value the lower the preference. The highest value of preference is 0.
Weight	Required; default value is 0. Specifies the weight percentage for which the service needs to load balance the peer. Note When you set the weight to a value other than 0, the weight should be in multiples of 10 and the sum of the weights configured in the peer list should be equal to 100.
IMSIRanges	Required; used for load balancing. The value is set to comma separated values of IMSI Ranges. For example, set IMSIRanges "112156000000001-112156001000000,112156010000001-112156011000000" Note Cisco Prime AR uses the AVP configured in StickyAVP property to check whether the IMSI is in valid range.
IsActive	Optional; if this is set to true, the new sessions will not go to the peer server. By default, this is set as false.

Use the Diameter Services List page for the following:

- [Filtering Records](#)
- [Adding Diameter Service Details](#)
- [Editing Records](#)
- [Deleting Records](#)

Adding Diameter Service Details

To add a new Diameter Service details:

-
- Step 1** Choose **Configuration > Services > Diameter**. The Diameter Services page is displayed.
 - Step 2** Click **Add** to add new Diameter service details. The Add DIAMETER- Services page is displayed.
 - Step 3** Specify the require details in the **PEER Statements**, **Applications**, and **PEER Definitions Proxy** specific sections.
 - Step 4** Click **Save DIAMETER Service** to save the specified details in the Diameter Services page. Otherwise click **Cancel** to return to the Diameter Services page without saving the details.

On successful creation of the Diameter Service properties, the Diameter Services page is displayed else a respective error message is displayed.

**Note**

You may need to enter **PEER Statements**, **Applications**, and **PEER Definitions Proxy** details based on the **Role** that you select in the DIAMETER-Services page.

Adding the PEER Statements Details

To add new PEER Statement details:

-
- Step 1** Click **Add** to add new PEER Statements details section. The fields specific to PEER Statements are displayed.
 - Step 2** Specify the required details.
 - Step 3** Click **Save** to save the specified details in the PEER Statements section. Otherwise click **Cancel** to return to the PEER Statements section without saving the details.

On successful creation of the Diameter Service properties, the Diameter Services page is displayed else a respective error message is displayed.

Adding the Applications Details

To add new Application details:

-
- Step 1** Click **Add** to add new Applications details in the Application List section. The fields specific to Applications are displayed.
 - Step 2** Specify the required details.
 - Step 3** Click **Save Appln** to save the specified details in the Application List section. Otherwise click **Cancel Appln** to return to the Application List section without saving the details.
-

Adding the PEER Definitions Proxy Details

To add PEER Definitions Proxy details:

-
- Step 1** Click **Add** to add new Proxy PEER Statements in the PEER Definitions Proxy section. The fields specific to Proxy PEER Statements are displayed.
- Step 2** Specify the required details.
- Step 3** Click **Save** to save the specified details in the Proxy PEER Statements section. Otherwise click **Cancel** to return to the Proxy PEER Statements section without saving the details.
-

Replication

The replication feature of Cisco Prime AR allows you to maintain identical configurations on multiple machines simultaneously. It eliminates the need to have administrators with multiple Cisco Prime AR installations, make the same configuration changes at each of their installations. Instead, only the master's configuration must be changed and the slave is automatically configured eliminating the need to make repetitive, error-prone configuration changes for each individual installation. In addition to enhancing server configuration management, using replication eliminates the need for a hot-standby machine.

Employing Cisco Prime AR's replication feature, both servers can perform RADIUS request processing simultaneously, eliminating wasted resources. It focuses on configuration maintenance only, not session information or installation-specific information.

[Table 3-16](#) lists and describes the fields in the Replication Details page.

Table 3-16 *Replication Properties*

Fields	Description
General Properties tab	
Replication Type	Indicates the type of replication
Transaction Sync Interval (in ms)	Duration between periodic transmission of the TransactionSync message expressed in milliseconds. The default is 60000 or 1 minute.
Transaction Archive Limit	The default setting is 100. The value set for RepTransactionArchiveLimit should be the same on the master and the slave.
Replication Secret	The value of this setting must be identical on both the master and the slave.
Is Master	On the master, set RepIsMaster to TRUE. On the slave, set it to FALSE.
Master IP Address	Specifies the IP Address of the master.
Master Port	Specifies the port to be used to send replication messages to the master.

Table 3-16 *Replication Properties (continued)*

Fields	Description
Replication IP Address	The value is set to the IP Address of the machine containing the Cisco Prime AR installation.
Replication Port	Defaults to port1645.
Replication Members tab	
Name	Name of the slave. The name must be unique.
IP Address	Indicates the IP Address of the slave.
Port	Port upon which the master will send replication messages to the slave.

Use the Replication Details page for the following:

- [Filtering Records](#)
- [Adding Replication Details](#)
- [Adding the Replication Member Details](#)
- [Editing Records](#)
- [Deleting Records](#)

Adding Replication Details

To add new replication details:

-
- Step 1** Choose **Configuration > Replication**. The Replication Details page is displayed.
 - Step 2** Specify the replication details.
 - Step 3** Enter the [Replication Member Details](#), if needed.
 - Step 4** Click **Save** to save the new replication details. Otherwise click **Reset** to restore the default values.

On successful creation of the replication details, a success message is displayed else a respective error message is displayed.

Adding the Replication Member Details

To add new replication member details:

-
- Step 1** Click the **Replication Members** tab. The List of Replication Members section is displayed.
 - Step 2** Enter the required details.
 - Step 3** Click **Submit** to save the new replication member details.
-

•

RADIUS Dictionary

The RADIUS dictionary passes information between a script and the RADIUS server, or between scripts running on a single packet.

[Table 3-17](#) lists and describes the fields in the Add Radius Attributes page. The fields listed below are the entire list of all the available types. The fields are displayed based on the type selected.

Table 3-17 RADIUS Dictionary Properties

Fields	Description
Name	Required; must be unique in the Radius dictionary list
Description	Optional; description of the attribute
Attribute	Required; must be a number between 1-255. It must be unique within the Attribute dictionary list.
Type	Required; type governs how the value is interpreted and printed.
Minimum	Set to zero
Maximum	Set to 253
Enum Number	Enums allow you to specify the mapping between the value and the strings. After you have established this mapping, Cisco Prime AR then replaces the number with the appropriate string. The min/max properties represent the lowest to highest values of the enumeration.
Enum Equivalent	The value can range from 1 through 255. Click the Add button to save the details and list it in the Enums list. To navigate between the listed attributes, use the navigation option available adjacent to the list. See Relocating Records for more details. To delete the available attributes, select the relevant attribute and click the Delete button below.
Tag	The tag number value can range from 0 through 31. The default value is zero.

Use the Radius Attributes page for the following:

- [Filtering Records](#)
- [Adding Radius Dictionary Details](#)
- [Editing Records](#)
- [Deleting Records](#)

Adding Radius Dictionary Details

To add new Radius dictionary details:

-
- Step 1** Choose **Configuration > Radius Dictionary**. The Radius Attributes page is displayed.
- Step 2** Click **Add** to add new Radius dictionary details. The Add RADIUS Dictionary page is displayed.
- Step 3** Enter the required details.

- Step 4** Click **Submit** to save the specified details in the Radius Attributes page. Otherwise click **Cancel** to return to the Radius Attributes page without saving the details.

On successful creation of the Radius Attributes, the Radius Attributes page is displayed else a respective error message is displayed.

•

Vendor Dictionary

The vendor dictionary allows the user to maintain the attributes of the vendor with respect to vendor id, vendor type and the attributes required to support the major NAS.

[Table 3-18](#) lists and describes the fields in the Add Vendor Dictionary page. The fields listed below are the entire list of all the available types. The fields are displayed based on the type selected.

Table 3-18 Vendor Dictionary Properties

Fields	Description
Name	Required; must be unique in the Vendor dictionary list
Description	Optional; description of the attribute
Vendor ID	Required; must be a valid number and unique within the entire attribute dictionary
Type	Required; type governs how the value is interpreted and printed.
Minimum	Optional; set to zero
Maximum	Optional; set to 253
Enum Number	Optional; enums allow you to specify the mapping between the value and the strings. After you have established this mapping, Cisco Prime AR then replaces the number with the appropriate string. The min/max properties represent the lowest to highest values of the enumeration.
Enum Equivalent	Optional; the value can range from 1 through 255. Click the Add button to save the details and list it in the Enums list. To navigate between the listed attributes, use the navigation option available adjacent to the list. See Relocating Records for more details. To delete the available attributes, select the relevant attribute and click the Delete button below.
Tag	Optional; the tag number value can range from 0 through 31. The default value is zero.
Vendor Size	Optional; set the vendor size to 8, 16, or 32 bit
HasSubAttributeLengthField	Optional; indicates that the value field of the attribute has the length field for the sub attribute.

Use the Vendor Dictionary page for the following:

- [Filtering Records](#)

- [Adding Vendor Dictionary Details](#)
- [Editing Records](#)
- [Deleting Records](#)

Adding Vendor Dictionary Details

To add new vendor dictionary details:

-
- Step 1** Choose **Configuration > Vendor Dictionary**. The Vendor Attributes page is displayed.
- Step 2** Click **Add** to add new Vendor dictionary details. The Add Vendor Dictionary page is displayed.
- Step 3** Enter the required details.
- Step 4** Click **Submit** to save the specified details in the Vendor Attributes page. Otherwise click **Cancel** to return to the Vendor Attributes page without saving the details.

On successful creation of the vendor dictionary details, the Vendor Attributes page is displayed else a respective error message is displayed.



Note After adding new vendor dictionary details, you can add vendor attributes details. Or you can also add vendor attributes details by clicking the link in the vendor dictionary list, see [Adding Vendor Attributes](#) for details.

Vendor Attributes

Vendor-specific attributes are included in specific RADIUS packets to communicate prepaid user balance information from the Cisco Prime AR server to the AAA client, and actual usage, either interim or total, between the NAS and the Cisco Prime AR server.

[Table 3-19](#) lists and describes the fields in the Add Vendor Attributes page.

Table 3-19 Vendor Attribute Properties

Fields	Description
Name	Required; must be unique in the Vendor attribute list
Description	Optional; description of the attribute
Attribute	Required; must be a valid number and unique within the entire attribute dictionary
Type	Required; type governs how the value is interpreted and printed.
Minimum	Optional; set to zero
Maximum	Optional; set to 253

Table 3-19 Vendor Attribute Properties (continued)

Fields	Description
Enum Number	Optional; enums allow you to specify the mapping between the value and the strings. After you have established this mapping, Cisco Prime AR then replaces the number with the appropriate string. The min/max properties represent the lowest to highest values of the enumeration.
Enum Equivalent	Optional; the value can range from 1 through 255. Click the Add button to save the details and list it in the Enums list. To navigate between the listed attributes, use the navigation option available adjacent to the list. See Relocating Records for more details. To delete the available attributes, select the relevant attribute and click the Delete button below.
Tag	Optional; the tag number value can range from 0 through 31. The default value is zero.

Use the Vendor Attributes page for the following:

- [Filtering Records](#)
- [Adding Vendor Attributes](#)
- [Editing Records](#)
- [Deleting Records](#)

Adding Vendor Attributes

To add new Vendor attributes:

-
- Step 1** Choose **Configuration > Vendor Dictionary**. The Vendor Attributes page is displayed.
 - Step 2** Click the Vendor name link. The Vendor Attributes page is displayed.
 - Step 3** Click **Add** to add new Vendor attributes. The Add Vendor Attributes page is displayed.
 - Step 4** Enter the required details.
 - Step 5** Click **Submit** to save the specified details in the Vendor Attributes page. Otherwise click **Cancel** to return to the Vendor Attributes page without saving the details.

On successful creation of the vendor attributes, the Vendor Attributes page is displayed else a respective error message is displayed.

Vendors

The **Vendor** object provides a central location for specifying all of the request and response processing a particular NAS or Proxy vendor requires. Depending on the vendor, it might be necessary to map attributes in the request from one set to another, or to filter out certain attributes before sending the response to the client. For more information about standard RADIUS attributes, see Appendix C, “RADIUS Attributes.” of *Cisco Prime Access Registrar, 6.0 User Guide*.



Note

When you have also set **/Radius/IncomingScript**, Cisco Prime AR runs that script before the vendor’s script. Conversely, when you have set a **/Radius/Outgoing** script, Cisco Prime AR runs the vendor’s script before that script.

Table 3-20 lists and describes the fields in the Add Vendor page.

Table 3-20 Vendor Properties

Fields	Description
Name	Required; must be unique in the Vendors list.
IncomingScript	Optional; when you specify an IncomingScript, Cisco Prime AR runs the script on all requests from clients that specify that vendor.
Description	Optional; description of the vendor.
OutgoingScript	Optional; when you specify an OutgoingScript, Cisco Prime AR runs the script on all responses to the Client.

Use the Vendors page for the following:

- [Filtering Records](#)
- [Adding Vendor Details](#)
- [Editing Records](#)
- [Deleting Records](#)

Adding Vendor Details

To add new Vendor details:

-
- Step 1** Choose **Configuration > Vendors**. The Vendors page is displayed.
 - Step 2** Click **Add** to add new Vendor details. The Add Vendor page is displayed.
 - Step 3** Enter the required details.
 - Step 4** Click **Submit** to save the specified details in the Vendors page. Otherwise click **Cancel** to return to the Vendors page without saving the details.

On successful creation of the vendor details, the Vendors page is displayed else a respective error message is displayed.

Translations

Translations add new attributes to a packet or change an existing attribute from one value to another. The **Translations** subdirectory lists all definitions of **Translations** the RADIUS server can apply to certain packets.

Under the **/Radius/Translations** directory, any translation to insert, substitute, or translate attributes can be added. The following is a sample configuration under the **/Radius/Translations** directory:

```
cd /Radius/Translations
Add T1
cd T1
Set DeleAttrs Session-Timeout,Called-Station-Id
cd Attributes
Set Calling-Station-Id 18009998888
```

DeleAttrs is the set of attributes to be deleted from the packet. Each attribute is comma separated and no spaces are allowed between attributes. All attribute value pairs under the attributes subdirectory are the attributes and values that are going to be added or translated to the packet.

Under the **/Radius/Translations/T1/Attributes** directory, inserted or translated attribute value pairs can be set. These attribute value pairs are either added to the packet or replaced with the new value.

If a translation applies to an Access-Request packet, by referencing the definition of that translation, the Cisco Prime AR server modifies the Request dictionary and inserts, filters and substitutes the attributes accordingly. You can set many translations for one packet and the Cisco Prime AR server applies these translations sequentially.



Note

Later translations can overwrite previous translations.

[Table 3-21](#) lists and describes the fields in the Add Translations page.

Table 3-21 *Translations Properties*

Fields	Description
General Properties tab	
Name	Required; must be unique in the Translations list.
Description	Optional; description of the Translation
Attribute Type	Optional; select either RADIUS or VENDOR . If Vendor is selected, specify the vendor type from the drop-down list. Select the attributes from the available list. To navigate between the listed attributes, use the navigation option available adjacent to the list. See Relocating Records for more details.
Attributes tab	
Attribute Type	Optional; select either RADIUS or VENDOR . If Vendor is selected, specify the vendor type from the drop-down list.
Attribute Name	Optional; based on the Attribute Type selected, the attribute name is automated. Set the relevant name for the attribute type selected.
Attribute Value	Optional; set the value for the selected attribute. Click the Add button to save the details and list it in Radius and Value list. To navigate between the listed attributes, use the navigation option available adjacent to the list. See Relocating Records for more details. To delete the available attributes, select the relevant attribute and click the Delete button below.

Use the Translations page for the following:

- [Filtering Records](#)
- [Adding Translation Details](#)
- [Editing Records](#)
- [Deleting Records](#)

Adding Translation Details

To add new translation details:

-
- Step 1** Choose **Configuration > Translations**. The Translations page is displayed.
 - Step 2** Click **Add** to add new translations details. The Add Translations page is displayed.
 - Step 3** Enter the required details.
 - Step 4** Click **Add Translation** to save the specified details in the Translations page. Otherwise click **Cancel** to return to the Translations page without saving the details.

On successful creation of the translation details, the Translations page is displayed else a respective error message is displayed.

Translation Groups

You can add translation groups for different user groups under **TranslationGroups**. All Translations under the Translations subdirectory are applied to those packets that fall into the groups. The groups are integrated with the Cisco Prime AR Rule engine.

The Cisco Prime AR Administrator can use any RADIUS attribute to determine the **Translation Group**. The incoming and outgoing translation group can be different translation groups. For example, you can set one translation group for incoming translations and one for outgoing translations.

Under the **/Radius/TranslationGroups** directory, translations can be grouped and applied to certain sets of packets, which are referred to in a rule. The following is a sample configuration under the **/Radius/TranslationGroups** directory:

```
cd /Radius/TranslationGroups
Add CiscoIncoming
cd CiscoIncoming
cd Translations
Set 1 T1
```

The translation group is referenced through the Cisco Prime AR Policy Engine in the **/Radius/Rules/<RuleName>/Attributes** directory. **Incoming-Translation-Groups** are set to a translation group (for example `CiscoIncoming`) and **Outgoing-Translation-Groups** to another translation group (for example `CiscoOutgoing`).

[Table 3-22](#) lists and describes the fields in the Add Translation Groups page.

Table 3-22 TranslationGroups Properties

Fields	Description
Name	Required; must be unique in the Translations list.
Description	Optional; description of the Translation Group.
Translations	Optional; lists of translation. To navigate between the listed attributes, use the navigation option available adjacent to the list. See Relocating Records for more details.

Use the Translation Groups page for the following:

- [Filtering Records](#)
- [Adding Translation Group Details](#)
- [Editing Records](#)
- [Deleting Records](#)

Adding Translation Group Details

To add new translation group details:

-
- Step 1** Choose **Configuration > TranslationGroups**. The Translation Groups page is displayed.
 - Step 2** Click **Add** to add new translation group details. The Add TranslationGroup page is displayed.
 - Step 3** Enter the required details.
 - Step 4** Click **Add TranslationGroup** to save the specified details in the Translation Groups page. Otherwise click **Cancel** to return to the Translation Groups page without saving the details.

On successful creation of the translation group details, the Translation Groups page is displayed else a respective error message is displayed.

DIAMETER

Diameter is a computer networking protocol for Authentication, Authorization and Accounting (AAA). It is a successor to RADIUS or an enhanced version of the RADIUS protocol. It includes numerous enhancements in all aspects, such as error handling and message delivery reliability. It extracts the essence of the AAA protocol from RADIUS and defines a set of messages that are general enough to be the core of the Diameter Base protocol. The various applications that require AAA functions can define their own extensions on top of the Diameter base protocol, and can benefit from the general capabilities provided by the Diameter base protocol.

The following sections can be used to configure diameter transportmanagement properties, sessionmanagement properties, add new application, commands associated with it and application specific AVPs:

- [General](#)

- [SessionManagement](#)
- [Applications](#)
- [Commands](#)

General

This section explains how to set Diameter general configuration such as product name, version, and transport management properties.

Setting General Diameter Parameters

[Table 3-23](#) lists and describes the fields in the General Diameter page.

Table 3-23 General Diameter Properties

Fields	Description
General section	
Product	Optional; name of the product.
AuthApplicationIdList	Specifies the list of AuthApplications that the Cisco Prime AR server registers to Diameter Base stack during start up. It is a combination of Auth ApplicationId's separated by colon.
Version	Optional; version number.
AcctApplicationIdList	Specifies the list of AcctApplications that the Cisco Prime AR server registers to Diameter Base stack during start up. It is a combination of Acct ApplicationId's separated by colon.
Transport Management section	
Identity	Required; identity of the system on which Diameter application is running. Must be set to a valid resolvable string.
Realm	Required; must be set to a valid Realm in the domain.
EnableIPV6	Required; if set to TRUE it enables IPV6 for the Diameter application.
WatchdogTimeout	Required; specifies the time interval between watch dog messages.
ReconnectInterval	Required; specifies the time interval between which Cisco Prime AR server attempts to connect to a disconnected peer. If set to 0, then no attempt will be made to connect to a disconnected peer.
MaxReconnections	Required; specifies the number of times Cisco Prime AR server tries to make a reconnection attempt. If set to 0, then no attempt will be made to reconnect.
RequestRetransmissionInterval	Required; the time for which retransmission of pending requests will be done. If set to 0, then no attempt will be made to retransmit.

Table 3-23 General Diameter Properties (continued)

Fields	Description
MaxRequestRetransmissionCount	Required, maximum number of times Cisco Prime AR server tries to retransmit a pending request. If set to 0, then no attempt will be made to retransmit.
Receive BufferSize	Required; initial size of buffer that is preallocated for message reception.
AdvertisedHostName	Optional, specifies the local hostname address that will be advertised by the Cisco Prime AR server to other peers during CER/CEA exchange. For example: AdvertisedHostNames = toby-ar1.cisco.com
TCPListenPort	Required; port number on which the Cisco Prime AR server listens for TCP peer connections.
SCTPListenPort	Required; port number on which the Cisco Prime AR server listens for SCTP peer connections.

Setting Up the General Diameter Parameters

To set up the general diameter parameters:

-
- Step 1** Choose **Configuration > Diameter > General**. The General Diameter page is displayed.
 - Step 2** Specify the required details.
 - Step 3** Click **Set** to save the specified details.

On successful creation of the general diameter parameters, a success message is displayed else a respective error message is displayed.

SessionManagement

Diameter Base protocol stack provides the functionality of SessionManagement. Base Stack maintains sessions separately for authentication and accounting messages. Session-Id AVP is used to identify the user session.

[Table 3-24](#) lists and describes the fields in the Session Management page.

Table 3-24 Session Management Properties

Fields	Description
Session Management section	
MaxNumberOfSessions	Required; specifies the maximum number of concurrent Diameter sessions the Cisco Prime AR server will maintain. These sessions include both Auth and Acct sessions.
AuthSessions section	

Table 3-24 Session Management Properties (continued)

Fields	Description
Session Management section	
EnableStatefulSessions	If set to TRUE, the server will enforce stateful sessions and the client will hint for stateful sessions. Default Value is TRUE. Set the property to FALSE to disable stateful sessions.
AuthSessionTimeout	Required; specifies the timeout in seconds before a session requires reauthentication.
LifeTimeTimeout	Required; specifies the timeout in seconds before a session is terminated regardless of whether the session has been re-authenticated.
GracePeriodTimeout	Required; specifies the grace period after the life timeout and before the full termination of the session.
AbortRetryTimeout	Required; specifies the timeout between the subsequent Abort Session Request (ASR) messages if the initial attempt fails.
AcctSessions section	
AcctSessionTimeout	Required; specifies the timeout in seconds before a session requires reauthentication.
InterimInterval	Required; specifies the interim interval dictated to the client if the entity is a server or hint to the server if the entity is a client.
RealTime	Required; RealTime value dictated to the client.

Setting Session Management Properties

To set up the session management properties:

- Step 1** Choose **Configuration > Diameter>SessionManagement**. The Session Management page is displayed.
- Step 2** Enter the required details and click **Set**.

On successful creation of the parameters, a success message is displayed else a respective error message is displayed.

Applications

A Diameter application is not a software application, but a protocol based on the Diameter base protocol (defined in RFC 6733). Each application is defined by an application identifier and can add new command codes and/or new mandatory AVPs.

When you click the Add button in the Applications page, the Application Details page is displayed. [Table 3-25](#) lists and describes the fields in the Application Details page.

Table 3-25 *Diameter Application Properties*

Fields	Description
Name	Required; name of the application.
Description	Optional; description of the application.
VendorSpecific	Required; the default is FALSE. If set to FALSE, the application is ordinary application and user is prompted to enter the ApplicationID. If set to TRUE, the application is a VendorSpecific Application. User is prompted to enter VendorSpecificApplicationID and VendorID.
AuthApplication	Required; if set to TRUE the application represents AuthApplication else it represents Accounting Application.
Application ID	Required; specifies the unique integer value for the application. The following are examples of Diameter application: NASREQ 1 Mobile-IP 2 Diameter Base Accounting 3 Note ApplicationId property must be set to 0 for Base Protocol.
VendorSpecificApplication-ID	Required; specifies the integer value for the vendor specific application.
VendorID	Required; specifies the VendorID for the application. Example: DIAMETER 3GPP Cx APPLICATION VendorSpecificApplicationID 16777216 VendorID 10415
ApplicationURI	Optional; specifies the URI of the Application. Eg: "ftp://ftp.ietf.org/internet-drafts/draft-ietf-aaa-diameter-nasreq-12.txt"
Commands	Required; an indexed list from 1 to <n>. Each entry in the list is the name of the command. It specifies the list of commands associated with the application. To navigate between the listed attributes, use the navigation option available adjacent to the list. See Relocating Records for more details.

Use the Applications page for the following:

- [Filtering Records](#)
- [Adding Diameter Application Details](#)
- [Commands](#)
- [Editing Records](#)
- [Deleting Records](#)

Adding Diameter Application Details

To add new Diameter application details:

-
- Step 1** Choose **Configuration > Diameter > Applications**. The Applications page is displayed.
 - Step 2** Click **Add**. The Application Details page is displayed.
 - Step 3** Enter the relevant details.
 - Step 4** Click **Add Application** to save the specified details in the Application Details page. Otherwise click **Cancel** to return to the Applications page without saving the details.
- On successful creation of the Applications details, a success message is displayed else a respective error message is displayed.
-

Commands

Each command in Diameter is associated with a command code. The command can be a request command or an answer command which is identified by the 'R' bit in the Command Flags field of the Diameter header.

When you click the Add button in the commands page, the Command Details page is displayed. [Table 3-26](#) lists and describes the fields in the Command Details page.

Table 3-26 *Diameter Commands Properties*

Fields	Description
Name	Required; name of the command.
Description	Optional; description of the command.
Command Code	Required; specifies the integer code of the command.
EnableProxyBit	Required; default is TRUE. When enabled it represents the message is proxiabile.
RequestFixed tab	Defines the fixed position of AVP in a request message.
RequestRequired tab	The AVP must be present and can appear anywhere in the request message.
RequestOptional tab	The AVP name in optional cannot evaluate to any avp name which is included in a fixed or required directory. The avp can appear anywhere in the request message.
AnswerFixed tab	Defines the fixed position of AVP in the answer message.
AnswerRequired tab	The AVP must present and can appear anywhere in the answer message.
AnswerOptional tab	The AVP name in optional cannot evaluate to any avp name which is included in a fixed or required directory. The avp can appear anywhere in the answer message.

You can click the Add button in the Command Details page to add the AVP details. [Table 3-27](#) lists and describes the fields displayed on clicking the **Add** button.

Table 3-27 Request/Answer Msg AVP Properties

Fields	Description
Name	Required; name of the AVP.
Description	Optional; description of the AVP.
Min	Specifies the minimum number of times AVP element may be present in a request. The default value is 0.
Max	Specifies the maximum number of times the element may present in a request. A value of zero implies AVP is not present in the request.

Adding Diameter Commands

To add the diameter commands:

-
- Step 1** Choose **Configuration > Diameter > Commands**. The Commands page is displayed.
 - Step 2** Click **Add**. The Add Commands page is displayed.
 - Step 3** Enter the relevant details.
 - Step 4** Click the required tab and click **Add** to enter the AVP details.
 - Step 5** Click **Save** to save the AVP details or click **Cancel** to exit the page without saving the details.
 - Step 6** Click **Add Command** to save the specified details in the Add Commands page. Otherwise click **Cancel** to return to the Commands page without saving the details.

The Commands page is displayed with the newly added details or a respective error message is displayed.

Advanced

Advanced objects allow configuring system-level properties and the Attribute dictionary. Under normal system operation, the system-level properties should not be changed.

The following list helps you in defining the system-level properties and attribute dictionary:

- [Default](#)
- [BackingStore/ServerParam](#)
- [RemoteSessionServer](#)
- [SNMP](#)
- [DDNS](#)
- [ODBC DataSources](#)

- [Log](#)
- [Ports](#)
- [Interfaces](#)
- [Attribute Groups](#)
- [Rules](#)

Default

This feature of GUI allows you in configuring the default values for other functionalities of GUI. The configurations set in this feature reflects on all the other features.

[Table 3-28](#) lists and describes the fields in the Default Advanced Details page.

Table 3-28 *Default Configuration Details*

Fields	Description
Default section	
AAAFileServiceSyncInterval	Required; specified in milliseconds, the default is 75. This property governs how often the file AAA service processes accounting requests and writes the accounting records to the file. You can lower the number to reduce the delay in acknowledging the Account-Request at the expense of more frequent flushing of the accounting file to disk. You can raise the number to reduce the cost of flushing to disk, at the expense of increasing the delays in acknowledging the Accounting-Requests . The default value was determined to provide a reasonable compromise between the two alternatives.
RemoteRadiusServerInterface	When set, specifies the local interface to bind to when creating the RemoteRadiusServer socket. If not set, the Cisco Prime AR binds to IPADDR_ANY.
MaximumNumberOfXML-Packets	Required when using identity caching. Indicates the maximum number of XML packets to be sent or received. The minimum value is 1 and the maximum is a 32-bit unsigned integer. The default is 1024.
MaximumODBCResultSize	Required; specifies maximum size in bytes for an ODBC mapping. This parameter affects both ODBC result sizes and the trace log buffer for tracing script calls that access any of the dictionaries. (Default value is 256.)
XMLUDPPacketSize	Required when using identity caching. Indicates the maximum size of XML packets to be sent or received. The minimum value is 1 and the maximum is a 32-bit unsigned integer. The default is 4096.
InitialBackgroundTimer-SleepTime	Required; the default is 5. This property specifies the amount of time the time queue should initially sleep before beginning processing. This property is only used for initial synchronization and should not be changed.

Table 3-28 Default Configuration Details (continued)

Fields	Description
RemoteLDAPServerThread- TimerInterval	Required; specified in milliseconds, the default is 10. This property governs how often the ldap RemoteServer thread checks to see if any results have arrived from the remote LDAP server. You can modify it to improve the throughput of the server when it proxies requests to a remote LDAP server.
AdvancedDuplicateDetec- tionMemoryInterval	Required when the Advanced Duplicate Detection feature is enabled. This property specifies how long (in milliseconds) Cisco Prime AR should remember a request. You must specify a number greater than zero. The default is 10,000.
RollingEncryptionKey- ChangePeriod	Used in conjunction with the session-cache ResourceManager, this property specifies the length of time a given EncryptionKey will be used before a new one is created. When the session-cache Resource-Manager caches User-Password attributes, Cisco Prime AR encrypts the User-Password so it is not stored in memory or persisted on disk in clear text. Cisco Prime AR uses up to 255 encryption keys, using a new one after each RollingEncryptionKeyChangePeriod expires. If RollingEncryptionKeyChangePeriod is set to <i>2 days</i> , Cisco Prime AR will create and begin using a new EncryptionKey every two days. The oldest key will be retired, and Cisco Prime AR will re-encrypt any User-Passwords that used the old key with the new key. This way, if the RollingEncryptionKeyChangePeriod is set to <i>1 day</i> , no key will be older than 255 days.
DefaultReturnedSubnetSize- IfNoMatch	Optional; used with the ODAP feature and reflects the returned size of the subnet if no matched subnet is found. There are three options to select if an exactly matched subnet does not exist: Bigger, Smaller, and Exact. The default is Bigger.
ODBCEnvironmentMultiVal- ueDelimiter	Optional; allows you to specify a character that separates multivalued attributes in the marker list when using Oracle (or ODBC) accounting
RemoteSigtranServerThread- TimerInterval	Required; specified in milliseconds, the default is 10. This property governs how often the sigtran RemoteServer thread checks to see if any results have arrived from the remote HLR/AuC server. You can modify it to improve the throughput of the server when it proxies requests to a remote sigtran server.
AdditionalNativeOracleEr- rors	Optional; 5 digit Oracle native error in order to disconnect the ODBC/OCI remote servers.

Table 3-28 *Default Configuration Details (continued)*

Fields	Description
AR Flags section	
HideSharedSecretAndPrivateKeys	<p>Optional; the default value is TRUE.</p> <p>The HideSharedSecretAndPrivateKeys property hides:</p> <ul style="list-style-type: none"> • The secret that is shared between a Radius Client and a Radius Server or between two radius servers in a radius proxy scenario. • The PrivateKeyPassword under the certificate-based EAP services. <p>When this property is set to TRUE, the following properties are displayed as <encrypted>:</p> <ul style="list-style-type: none"> • PrivateKeyPasswords in: <ul style="list-style-type: none"> – peap-v0 service – peap-v1 service – eap-tls service – eap-ttls service – eap-fast service • SharedSecret in: <ul style="list-style-type: none"> – RemoteServers of type radius – RemoteServers of type map-gateway – Clients object – Resource Manager of type usr-vpn under Gateway subobject • PseudonymSecret in eap-sim service • DynamicAuthSecret under DynamicAuthorizationServer subject in Clients object • RepSecret under Replication • Secret in /radius/advanced/DDNS/TSIGKeys <p>When the value for this property is set to FALSE, all the above properties are displayed in clear text.</p>
ListenForDynamicAuthorizationRequests	<p>Must be set to TRUE when using the Change of Authorization (CoA) feature or Packet of Disconnect (POD) feature. Default is FALSE.</p>
RequireNASsBehindProxyBeInClientList	<p>Optional; the default is FALSE. If you accept the default, Cisco Prime AR only uses the source IP address to identify the immediate client that sent the request. Leaving it FALSE is useful when this RADIUS Server should only know about the proxy server and should treat requests as if they came from the proxy server. This might be the case with some environments that buy bulk dial service from a third party and thus do not need to, or are unable to, list all of the NASs behind the third party's proxy server. When you set it to TRUE, you must list all of the NASs behind the Proxy in the Clients list.</p>

Table 3-28 Default Configuration Details (continued)

Fields	Description
UseAdvancedDuplicateDetection	Required; the default is FALSE. Set this property to TRUE when you want Cisco Prime AR to use a more robust duplicate request filtering algorithm.
DetectOutOfOrderAccountingPackets	<p>Optional; used to detect accounting packets that arrive out of sequential order. The default is FALSE. This property is useful when using accounting and session management in a RADIUS proxy service.</p> <p>When the DetectOutOfOrderAccountingPacket property is enabled (set to TRUE), a new <i>Class</i> attribute is included in all outgoing Accept packets. The value for this Class attribute will contain the session magic number. The client will echo this value in the accounting packets, and this will be used for comparison.</p> <p>The session magic number is a unique number created for all sessions when the session is created or reused and the DetectOutOfOrderAccountingPacket property is set to TRUE. The DetectOutOfOrderAccountingPacket property is used to detect out-of-order Accounting-Stop packets in roaming scenarios by comparing the session magic number value in the session with the session magic number value contained in the Accounting packet.</p> <p>The value of 0xffffffff is considered by the Cisco Prime AR server to be a wild card magic number. If any accounting stop packets contain the value of 0xffffffff, it will pass the session magic validation even if the session's magic number is something else.</p> <p>The format of the class attribute is as follows:</p> <p style="padding-left: 40px;"><4-byte Magic Prefix><4-byte server IP address><4-byte Magic value></p>
Java & EAP Parameters section	
ClasspathForJavaExtensions	<p>A string which is the classpath to be used to locate Java classes and jar files containing the classes required for loading the Java extensions, either Java extension points or services.</p> <p>Note The classpath will always contain the directory \$INSTALL-DIR/scripts/radius/java and all of the jar files in that directory.</p>
JavaVMOptions	A string that can contain options to be passed to the JRE upon startup. JavaVMOptions should be used only when requested by Cisco TAC.

Table 3-28 *Default Configuration Details (continued)*

Fields	Description
EapBadMessagePolicy	Set to one of two values: SilentDiscard (the default) or RejectFailure. When set to SilentDiscard, the Cisco Prime AR server silently discards and ignores bad EAP messages unless the protocol specification explicitly requires a failure message. When set to RejectFailure, the Cisco Prime AR server sends RADIUS Access-Rejects messages with embedded EAP-Failure in response to bad EAP messages as described in Internet RFC 3579.
CertificateDBPath	Required if you are using an LDAP RemoteServer and you want Cisco Prime AR to use SSL when communicating with that LDAP RemoteServer. This property specifies the path to the directory containing the client certificates to be used when establishing an SSL connection to an LDAP RemoteServer. This directory must contain the cert7.db and cert5.db certificates and the key3.db and key.db files database used by Netscape Navigator 3.x (and above) or the ServerCert.db certificate database used by Netscape 2.x servers.

Setting Default Configuration

To set up the default configuration details:

-
- Step 1** Choose **Configuration > Advanced > Default**. The Default Advanced Details page is displayed.
 - Step 2** Enter the relevant details.
 - Step 3** Click **Set** to save the specified details in the Default Advanced Details page. Otherwise, click **Reset** to restore the default values. On successful creation of the default configurations, a success message is displayed else a respective error message is displayed.
-

BackingStore/ServerParam

The Backing Store is a Parsing Tool which helps you in analyzing the session backing store files. It retrieves the information on Radius sessions, clears phantom sessions details manually and processes the binary log files information to user-readable format.

The Server parameters are set to configure objects to remote server using the relevant aregcmd commands.

Table 3-29 lists and describes the fields in the Backing/ServerParam Advanced Details page.

Table 3-29 BackingStore/ServerParameter Properties

Fields	Description
Backing Store section	
SessionBackingStoreSyncInterval	Sessions will be written to the backing store at this interval
PacketBackingStoreSyncInterval	The minimum value is 1 and the maximum is a 32-bit unsigned integer. The default is 75.
SessionBackingStorePruneInterval	<p>Required; specifies the sleep time interval of the session backing store pruning thread. The recommended and default value is 6 hours, but you can modify this based on the traffic patterns you experience.</p> <p>With SessionBackingStorePruneInterval set to 6 hours, pruning will occur 6 hours after you restart or reload the Cisco Prime AR server and recur every 6 hours.</p> <p>You can set a very low value for this property to make pruning continuous, but there might not be enough data accumulated for the pruning to occur and pruning might be less effective compared to the default setting.</p>
PacketBackingStorePruneInterval	<p>Required; specifies the sleep time interval of the packet backing store pruning thread. The recommended value is 6 hours, but you can modify this based on the traffic patterns you experience.</p> <p>When PacketBackingStorePruneInterval is set to 6 hours, pruning will occur 6 hours after you restart or reload the Cisco Prime AR server and recur every 6 hours.</p> <p>You can set a very low value for this property to make pruning continuous, but there might not be enough data accumulated for the pruning to occur and pruning might be less effective compared to the default setting.</p>
BackingStoreDiscThreshold	<p>Required; the default is 10 gigabytes. The value of BackingStoreDiscThreshold is made up of a number of units which can be K, kilobyte, or kilobytes, M, megabyte, or megabytes, or G, gigabyte, or gigabytes.</p> <p>BackingStoreDiscThreshold is used with session management and ODBC accounting and ensures that any data log files generated will not cross the BackingStoreDiscThreshold.</p>

Table 3-29 *BackingStore/ServerParameter Properties (continued)*

Fields	Description
SessionPurgeInterval	<p>Optional; the SessionPurgeInterval property determines the time interval at which to check for timed-out sessions. If no value is set, the session timeout feature is disabled. The checks are performed in the background when system resources are available, so checks might not always occur at the exact time set.</p> <p>The minimum recommended value for SessionPurgeInterval is 60 minutes. The SessionPurgeInterval value is comprised of a number and a units indicator, as in n units, where a unit is one of minutes, hours, days, or weeks.</p>
StaleSessionTimeout	<p>Required; the default value is “1 hour.” Specifies the time interval to maintain a session when a client does not respond to Accounting-Stop notification.</p> <p>When the Cisco Prime AR server does not receive an Accounting-Response from a client after sending an Accounting-Stop packet, Cisco Prime AR maintains the session for the time interval configured in this property before releasing the session.</p> <p>This property is stored as a string composed of two parts: a number and a unit indicator (<n> <units>) similar to the MaxFileAge property where the unit is one of: M, Minute, Minutes, H, Hour, Hours, D, Day, Days, W, Week, or Weeks.</p>
NumberOfRadiusIdentifiersPerSocket	<p>This represents the number of RADIUS Identifiers that Cisco Prime AR can use per source port, while proxying requests to remote servers.</p> <p>To use a different source port for every request that is proxied, you need to set the value of this property to one.</p>
EnableStickySessionCount	<p>Required; either True or False and the default value is True. When set to True, Cisco Prime AR displays the peer specific stats showing the number of sticky sessions associated with a peer for diameter proxy service in name_radius_log file.</p>
StickySessionCountInterval	<p>Required; specified in milliseconds and the default is 60000. When the EnableStickySessionCount is set to True, this field specifies how often the diameter proxy service will display the number of sticky sessions associated with a peer.</p>
StickySessionSyncInterval	<p>Required; specified in milliseconds and the default value is 500. Specifies how often the diameter proxy service will write the sticky sessions to a file located in /cisco-ar/temp/__sticky_sessions_store location.</p>

Table 3-29 BackingStore/ServerParameter Properties (continued)

Fields	Description
Server Parameters section	
MaximumNumberOfRadiusPackets	Required; the default is 8192. This is a critical property you should set high enough to allow for the maximum number of simultaneous requests. When more requests come in than there are packets allocated, Cisco Prime AR will drop those additional requests.
NumberOfRemoteUDPServerSocket	<p>Required; the default value for this property is 4.</p> <p>The NumberOfRemoteUDPServerSockets property allows you to configure the number of source ports used while proxying requests to a remote radius server. If the NumberOfRemoteUDPServerSockets property is set to a value n, all remote servers share and use n sockets.</p> <p>The NumberOfRemoteUDPServerSockets value comprises a number, as in n, where n should be less than or equal to the current process file descriptor limit divided by 2.</p> <p>Note By default, the Radius process supports up to 1024 file descriptors. To increase the file descriptors, stop the arserver; in the arserver script, specify the required value to "NUMBER_OF_FILE_DESCRIPTOR" and restart the server. The value for "NUMBER_OF_FILE_DESCRIPTOR" should be in the range between 1024 to 65535.</p>
MemoryLimitForRadiusProcess	This property is used to avoid crashing of the radius process.
UDPPacketSize	Required; the default is 4096. RFC 2138 specifies the maximum packet length can be 4096 bytes. Do not change this value.
PerPacketHeapSize	Required; the default is 6500. This property sets the size of the initial heap for each packet. The heap is the dynamic memory a request can use during its lifetime. By preallocating the heap size at the beginning of request processing, we can minimize the cost of memory allocations. If PerPacketHeapSize is too low, Cisco Prime AR will ask the system for memory more often. If PerPacketHeapSize is too high, Cisco Prime AR will allocate too much memory for the request causing the system to use more memory than required.
MinimumSocketBufferSize	Required; the default is 65536 (64 K). This property governs how deep the system's buffer size is for queueing UDP datagrams until Cisco Prime AR can read and process them. The default is probably sufficient for most sites. You can, however, raise or lower it as necessary.

Table 3-29 *BackingStore/ServerParameter Properties (continued)*

Fields	Description
MaximumOutstandingRequests	Optional; the default value for this property is 0. The MaximumOutstandingRequests property is used to limit the incoming traffic in terms of “requests processed”. Serves as a hard limit. The MaximumOutstandingRequests property comprises a number <i>n</i> , where <i>n</i> can be any nonzero value.
MaximumIncomingRequests	Optional; the default value for this property is 0.
ARIsCaseInsensitive	When set to FALSE, requires that you provide exact pathnames with regard to upper and lower case for all objects, subobjects, and properties. The default setting, TRUE, allows you to enter paths such as /rad/serv instead of /Rad/Serv . Note Cisco Prime AR always authenticates the RADIUS attribute User-Name with regard to upper and lower case, regardless of the setting of this flag.
KeyStores -> EAP-FAST section	
EnableDiameter	Optional; Either TRUE or FALSE; default is TRUE. Set to True when you want to use the Diameter protocol in Cisco Prime AR.
NumberOfKeys	Number (from 1-1024) that specifies the maximum number of keys stored for EAP-FAST.
RolloverPeriod	Specifies the amount of time between key updates.

Setting Server Parameters

To set up new server parameters:

-
- Step 1** Choose **Configuration > Advanced > Backing/ServerParam**. The Backing/ServerParam Advanced Details page is displayed.
 - Step 2** Specify the relevant details.
 - Step 3** Click **Set** to save the specified details in the Backing/ServerParamAdvanced Details page.

On successful creation of the server parameters, a success message is displayed else a respective error message is displayed.

RemoteSessionServer

Cisco Prime AR sessions can also be stored on a remote database. This improves the overall scalability of the number of sessions that Cisco Prime AR can simultaneously handle.

The remote session manager internally uses the following two ODBC remote servers:

- Internal-ODBC-Read-Server
- Internal-ODBC-Write-Server.

Configurations pertaining to these internal remoteservers can be done under the RemoteSessionServer section.

**Note**

Ensure that the length of fields such as Username, Session/Resource Manager name Session-Key, Query-Key and so on are limited to the value specified in the schema, while it is configured. Although the field length of entire session record is 3KB it is limited to 2KB. This is practically sufficient to hold all the session parameters as well as the cached attributes (if any). For more information about the schema, see section Remote Session Management of the *Cisco Prime Access Registrar 6.0 User Guide*: http://www.cisco.com/en/US/docs/net_mgmt/access_registrar/6.0/user/guide/features.html

**Note**

Remote session manager will work only with Oracle database.

Table 3-30 lists and describes the fields in the RemoteSessionServer Advanced Details page.

Table 3-30 RemoteSessionServer Properties

Fields	Description
RemoteSessionServer section	
ReactivateTimerInterval	Mandatory time interval (in milliseconds) to activate an inactive server; defaults to 300000 ms.
Timeout	Mandatory time interval (in seconds) to wait for SQL operation to complete; defaults to 15 seconds
DataSourceConnections	Mandatory number of connections to be established; defaults to 8
ODBCDataSource	Name of the ODBCDataSource to use and must refer to one entry in the list of ODBC datasources configured under /Radius/Advanced/ODBCDataSources . Mandatory; no default.
KeepAliveTimerInterval	Mandatory time interval (in milliseconds) to send a keepalive to keep the idle connection active; defaults to zero (0) meaning the option is disabled
MaximumBufferFileSize	Mandatory if BufferAccountingPackets is set to TRUE, determines the maximum buffer file size, defaults to 10 Megabyte)
CacheLimit	Default is 250000; This represents the overall limit on cache of all 'remote' session managers. This value is interpreted as the maximum number of packets that can be present in cache. When the number of sessions hits this limit, sessions will be 'cached out'. This cache out operation will continue, until the cache is at least 20% free.

Table 3-30 RemoteSessionServer Properties (continued)

Fields	Description
BufferAccountingPackets	Mandatory, TRUE or FALSE, determines whether to buffer the accounting packets to local file, defaults to TRUE which means that packet buffering is enabled. Note When set to TRUE, a constant flow of incoming accounting packets can fill the buffer backing store files in /cisco-ar/data/odbc beyond the size configured in MaximumBufferFileSize. Configure BackingStoreDiscThreshold in /Radius/Advanced when using ODBC accounting.
UseCacheIndex	Mandatory; If set to 1, it enables a fast cache based lookup index for the items in the database. This optimizes the number of queries to the database hence will improve performance, but limits the number of sessions that can be scaled. If set to 0, it disables fast cache based lookup index.

Setting RemoteSessionServer Details

To set a new RemoteSessionServer details:

-
- Step 1** Choose **Configuration > Advanced > RemoteSessionServer**. The RemoteSessionServer Advanced Details page appears.
 - Step 2** Specify the relevant details.
 - Step 3** Click **Set** to save the specified details in the RemoteSessionServer Advanced Details page.
- On successful creation of the RemoteSessionServer details, a success message is displayed else a respective error message is displayed.
-

SNMP

Cisco Prime AR provides SNMP MIB for users of network management systems. The supported MIBs enable the network management station to collect state and statistic information from a Cisco Prime AR server. It enables a standard SNMP management station to check the current state of the server as well as the statistics on each client or each proxy remote server. These messages contain information indicating that either the server was brought up or down or that the proxy remote server is down or has come back online.

[Table 3-31](#) lists and describes the fields in the SNMP Advanced Details page.

Table 3-31 SNMP Properties

Fields	Description
SNMP Info section	
InputQueueHighThreshold	An integer; default is 90.

Table 3-31 SNMP Properties (continued)

Fields	Description
InputQueueLowThreshold	An integer; default is 60.
Enabled	Either TRUE or FALSE; default is FALSE. To disable SNMP setting, uncheck the Enabled check box.
TracingEnabled	Either TRUE or FALSE; default is FALSE.
MasterAgentEnabled	Either TRUE or FALSE; default is TRUE.
RFC Compliance Info section	
AllowRejectAttrs	When AllowRejectAttrs is set to FALSE, Reply-Message attributes will not be passed in an Access Reject packet. When AllowRejectAttrs is set to TRUE, attributes will be allowed to pass in an Access Reject packet.
AllowEAPRejectAttrs	When AllowEAPRejectAttrs is set to FALSE, Reply-Message attributes will not be passed in an Access Reject packet if the packet contains EAP-Message attribute. When AllowEAPRejectAttrs is set to TRUE, attributes will be allowed to pass in an Access Reject packet even if the packet contains EAP-Message attribute.
Reply Messages section	
Default	Optional; when you set this property, Cisco Prime AR sends this value when the property corresponding to the reject reason is not set.
UnknownUser	Optional; when you set this property, Cisco Prime AR sends back this value in the Reply-Message attribute whenever Cisco Prime AR cannot find the user specified by User-Name .
UserNotEnabled	Optional; when you set this property, Cisco Prime AR sends back this value in the Reply-Message attribute whenever the user account is disabled.
UserPasswordInvalid	Optional; when you set this property, Cisco Prime AR sends back this value in the Reply-Message attribute whenever the password in the Access-Request packet did not match the password in the database.
UnableToAcquireResource	Optional; when you set this property, Cisco Prime AR sends back this value in the Reply-Message attribute whenever one of the Resource Managers was unable to allocate the resource for this request.
ServiceUnavailable	Optional; when you set this property, Cisco Prime AR sends back this value in the Reply-Message attribute whenever a service the request needs (such as a RemoteServer) is unavailable.
InternalError	Optional; when you set this property, Cisco Prime AR sends back this value in the Reply-Message attribute whenever an internal error caused the request to be rejected.
MalformedRequest	Optional; when you set this property, Cisco Prime AR sends back this value in the Reply-Message attribute whenever a required attribute (such as User-Name) is missing from the request.

Table 3-31 *SNMP Properties (continued)*

Fields	Description
ConfigurationError	Optional; when you set this property, Cisco Prime AR sends back this value in the Reply-Message attribute whenever the request is rejected due to a configuration error. For example, if a script sets an environment variable to the name of an object such as Authentication-Service , and that object does not exist in the configuration, the reason reported is ConfigurationError.
IncomingScriptFailed	Optional; when you set this property, Cisco Prime AR sends back this value in the Reply-Message attribute whenever one of the IncomingScripts fails to execute.
OutgoingScriptFailed	Optional; when you set this property, Cisco Prime AR sends back this value in the Reply-Message attribute whenever one of the OutgoingScripts fails to execute.
IncomingScriptRejectedRequest	Optional; when you set this property, Cisco Prime AR sends back this value in the Reply-Message attribute whenever one of the IncomingScripts rejects the Access-Request.
TerminationAction	Optional; when you set this property, Cisco Prime AR sends back this value in the Reply-Message attribute whenever Cisco Prime AR processes the Access-Request as a Termination-Action and is being rejected as a safety precaution.
OutgoingScriptRejectedRequest	Optional; when you set this property, Cisco Prime AR sends back this value in the Reply-Message attribute whenever one of the OutgoingScripts rejects the Access-Request.

Setting SNMP Details

To set up new SNMP details:

-
- Step 1** Choose **Configuration > Advanced > SNMP**. The SNMP Advanced Details page is displayed.
 - Step 2** Specify the relevant details.
 - Step 3** Click **Set** to save the specified details in the SNMP Advanced Details page.

On successful creation of the SNMP details, a success message is displayed else a respective error message is displayed.

DDNS

Cisco Prime AR supports Dynamic DNS Remote server. It is a method, protocol, or network that notifies the server to change the active DNS configuration of its configured hostnames, addresses or other information stored in DNS.

You can click the Add button in the DDNS Details page to enter the TSIGKeys details in the TSIGKeys Details section.

Table 3-32 lists and describes the fields in the TSIGKeys Details section.

Table 3-32 TSIGKeys Properties

Fields	Description
Name	Name of the TSIG Key.
Secret	Set to the same base64-encoded string as defined in the DNS server.
Description	Description of the TSIG Key

Use the DDNS Details page for the following:

- [Filtering Records](#)
- [Setting DDNS Details](#)
- [Adding the TSIGKeys for DDNS](#)
- [Editing Records](#)
- [Deleting Records](#)

Setting DDNS Details

To set up new DDNS details:

-
- Step 1** Choose **Configuration > Advanced > DDNS**. The DDNS Details page is displayed.
- Step 2** Check the **SynthesizeReverseZone** check box, and click **Set DDNS**.
-

Adding the TSIGKeys for DDNS

To add TSIGKeys details for DDNS:

-
- Step 1** Choose **Configuration > Advanced > DDNS**. The DDNS Details page is displayed.
- Step 2** Click **Add**. The TSIGKeys details section is displayed.
- Step 3** Enter the relevant details.
- Step 4** Click **Add** to save the specified details in the TSIGKeys Details section.

On successful creation of the TSIGKeys details, a success page is displayed else a respective error message is displayed.

ODBC DataSources

Cisco Prime AR uses ODBC as the datasource name to be used by the remote server. Multiple remote servers can use the same ODBCDataSource. Under the ODBCDataSource object definition, a list defines **ODBC.ini** filename/value pairs for a connection. The list includes a Type field and a Driver field, different for each Driver and Data Source, to indicate its Driver and Data Source. Cisco Prime AR supports only the Easysoft Open Source Oracle Driver.

Table 3-33 lists and describes the fields in the Add ODBC DataSources page.

Table 3-33 ODBCDataSource Properties

Fields	Description
Name	Name of the ODBCDataSource
Description	Optional; Description of the ODBC Data Source
Type	Required; must be Oracle_es
Driver	Required; liboarodbc.so (default value) Note This attribute is supported only for OBDC.
UserID	Required; database username (no default value)
Password	Optional; user password; shown encrypted
DataBase	Required; Oracle Client configuration database name (no default value)
Server	Set the name of the server
Port	Set the port details.

Use the ODBC DataSources page for the following:

- [Filtering Records](#)
- [Adding ODBC Data Source](#)
- [Log](#)
- [Editing Records](#)
- [Deleting Records](#)

Adding ODBC Data Source

To add new ODBC data source details:

-
- Step 1** Choose **Configuration > Advanced > ODBC DataSources**. The ODBC DataSources page is displayed.
 - Step 2** Click **Add** to add new ODBC data source details. The ODBC DataSources Details page is displayed.
 - Step 3** Enter the relevant details.
 - Step 4** Click **Submit** to save the specified details. Otherwise click **Cancel** to return to the ODBC DataSources page without saving the details.

The ODBC DataSources page is displayed with the newly added details and a success message is displayed else a respective error message is displayed.

Log

The log files defined in Cisco Prime AR assist you in identifying the issues related to it. Cisco Prime AR holds sets of log files to store information relevant to server agent processes, monitoring arserver utility, execution of aregcm commands, mcd internal database details, radius server processes and debug details of RADIUS request process.

Table 3-34 lists and describes the fields in the Log Files page.

Table 3-34 Log Details

Fields	Description
GUI Log Settings section	
LOG LEVEL	Select either debug level or Error.
MaxFileSize	Set the maximum size of the log file.
Advance Details section	
LogFileSize	<p>Required; the default is 1 megabyte. This property specifies the maximum size of the RADIUS server log file. The value for the LogFileSize field is a string composed of two parts; a number, and a units indicator (<n> <units>) in which the unit is one of: K, kilobyte, kilobytes, M, megabyte, megabytes, G, gigabyte, or gigabytes.</p> <p>The LogFileSize property does not apply to the config_mcd_1_log or agent_server_1_log files.</p> <p>Note This does not apply to the trace log.</p>
LogFileCount	<p>Required; the default is 2. This property specifies the number of log files to be kept on the system. A new log file is created when the log file size reaches LogFileCount.</p> <p>The LogFileCount property does not apply to the config_mcd_1_log or agent_server_1_log files.</p>
TraceFileSize	<p>Required; the default is 1 GB. This property specifies the size of the trace files to be kept on the system. A new trace file is created when the trace file size reaches TraceFileSize. The value for the TraceFileSize field is a string composed of two parts; a number, and a units indicator (<n> <units>) in which the unit is one of: K, kilobyte, kilobytes, M, megabyte, megabytes, G, gigabyte, or gigabytes.</p>
TraceFileCount	<p>Required; this value can be set from 1–100, and the default is 2. This property specifies the number of trace files to maintain. A value of 1 indicates that no file rolling occurs.</p>
LogServerActivity	<p>Required; the default is FALSE, which means Cisco Prime AR logs all responses except Access-Accepts and Access-Challenges. Accepting the default reduces the load on the server by reducing that amount of information it must log. Note, the client is probably sending accounting requests to an accounting server, so the Access-Accept requests are being indirectly logged. When you set it to TRUE, Cisco Prime AR logs all responses to the server log file.</p>
TraceLevel	Set the trace level.

Use the Log Files page for the following:

- [Filtering Records](#)
- [Viewing Log Details](#)
- [Downloading Log Details](#)
- [Setting Log Details](#)

Viewing Log Details

To view the log files:

-
- Step 1** Choose **Configuration > Advanced > Log**. The Log Files page is displayed.
- Step 2** Choose the appropriate radio button and click **View** to view the file.
-

Downloading Log Details

To download the log files:

-
- Step 1** Choose **Configuration > Advanced > Log**. The Log Files page is displayed.
- Step 2** Choose the appropriate radio button and click **Download** to download the file.
-

Setting Log Details

To set the log details:

-
- Step 1** Choose **Configuration > Advanced > Log**. The Log Files page is displayed.
- Step 2** Enter the relevant details and click **Set** to save the specified details.
-

Ports

The Ports list specifies which ports to listen to for requests. When you specify a port, Cisco Prime AR makes no distinction between the port used to receive Access-Requests and the port used to receive Accounting-Requests. Either request can come in on either port.

Most NASs send Access-Requests to port 1645 and Accounting-Requests to 1646, however, Cisco Prime AR does not check.

When you do not specify any ports, Cisco Prime AR reads the `/etc/services` file for the ports to use for access and accounting requests. If none are defined, Cisco Prime AR uses the standard ports (1645 and 1646).

Table 3-35 lists and describes the fields in the Ports page.

Table 3-35 Port Properties

Fields	Description
Port	Required; allows you to use ports other than the default, 1645 and 1646. You can use this option to configure Cisco Prime AR to use other ports,. If you add additional ports, however, Cisco Prime AR will use the added ports and no longer use ports 1645 and 1646. These ports can still be used by adding them to the list of ports to use.
Type	Set the port type.
Description	Optional; description of the port.

Use the Ports page for the following:

- [Filtering Records](#)
- [Adding Port Details](#)
- [Interfaces](#)
- [Editing Records](#)
- [Deleting Records](#)

Adding Port Details

To add new port details:

-
- Step 1** Choose **Configuration > Advanced > Port**. The Ports page is displayed.
- Step 2** Enter the relevant details and click **Add**. The new port details will be listed in the Ports page.
-

Interfaces

The Interfaces list specifies the interfaces on which the RADIUS server receives and sends requests. You specify an interface by its IP address.

- When you list an IP address, Cisco Prime AR uses that interface to send and receive Access-Requests.
- When no interfaces are listed, the server performs an interface discover and uses all interfaces of the server, physical and logical (virtual).



Note

The IP address format is enhanced to support both IPv4 and IPv6.

Use the interfaces page for the following:

- [Filtering Records](#)
- [Adding IP Addressing Interface](#)
- [Deleting Records](#)

Adding IP Addressing Interface

To add a new IP address interface to define an interface:

Step 1 Choose **Configuration > Advanced > Interfaces**. The Interfaces page is displayed.

Step 2 Enter the **IP Address** and click **Add**.

The Interfaces page is displayed with the newly added details and a success message is displayed else a respective error message is displayed.

Attribute Groups

The Attributes can be grouped using Cisco Prime AR Profile object. The attributes for a particular user group can be grouped under a profile and the attributes contained in the profiles will be returned in their access-accepts.

[Table 3-36](#) lists and describes the fields in the Attribute Groups Details page.

Table 3-36 *AttributeGroups Properties*

Fields	Description
Name	Name of the attribute group.
Description	Optional; description of the attribute group.
Attribute type	Select either RADIUS or VENDOR . If Vendor is selected, specify the vendor type from the drop-down list.
Attribute Name	Optional; based on the Attribute Type selected, the attribute name is automated. Set the relevant name for the attribute type selected. Click the Add button to save the details and list it in Attribute list. To navigate between the listed attributes, use the navigation option available adjacent to the list. See Relocating Records for more details. To delete the available attributes, select the relevant attribute and click the Delete button below.

Use the Attribute Groups page for the following:

- [Filtering Records](#)
- [Adding Attribute Group Details](#)
- [Rules](#)
- [Editing Records](#)
- [Deleting Records](#)

Adding Attribute Group Details

To add new attribute groups details:

Step 1 Choose **Configuration > Advanced > Attributes Groups**. The Attribute Groups page is displayed.

Step 2 Click **Add** to add new attribute group details. The Attribute Group Details page is displayed.

Step 3 Enter the relevant details.

Step 4 Click **Submit** to save the specified details in the Attribute Groups Details page. Otherwise click **Cancel** to return to the Attribute Groups page without saving the details.

The Attribute Groups page is displayed with the newly added details or a respective error message is displayed.

Rules

A Rule is a function that selects services based on all input information used by the function.

[Table 3-37](#) lists and describes the fields in the Add Rules List page.

Table 3-37 Rule Properties

Fields	Description
General Properties tab	
Name	Required; must be unique in the Rule list.
Description	Optional; description of the rule.
Type	Required; specifies the type of the rule which can be Radius or Diameter.
Script Name	Name of the script.
Attribute Details tab	
The fields displayed in the tab is displayed based on the type of the rule selected in the Type field.	
RADIUS	Optional; set Radius, if the attribute and value needs to be defined for Radius.
VENDOR	Optional; set Vendor, if the attribute and value needs to be defined for Vendor.
AttributeName	Optional; based on the Attribute Type selected, the attribute name is automated. Set the relevant name for the attribute type selected.
AttributeValue	Optional; set the value for the selected attribute. Click the Add button to save the details and list it in Name and Value list. To navigate between the listed attributes, use the navigation option available adjacent to the list. See Relocating Records for more details. To delete the available attributes, select the relevant attribute and click the Delete button below.

Use the Rules List page for the following:

- [Filtering Records](#)
- [Setting Rules](#)
- [Session Managers](#)
- [Editing Records](#)
- [Deleting Records](#)

Setting Rules

To set new rules:

-
- Step 1** Choose **Configuration > Rules**. The List of Rules page is displayed.
 - Step 2** Click **Add**. The Rules Details page is displayed.
 - Step 3** Enter the relevant details.
 - Step 4** Click **Submit** to save the specified details in the Rules Details page. Otherwise click **Cancel** to return to the List of Rules page without saving the details.

The List of Rules page is displayed with the newly added details or a respective error message is displayed.

Session Managers

You can use Session Managers to track user sessions. The Session Managers monitor the flow of requests from each NAS and detect the session state. When requests come through to the Session Manager, it creates sessions, allocates resources from appropriate Resource Managers, and frees and deletes sessions when users log out.

The Session Manager enables you to allocate dynamic resources to users for the lifetime of their session. You can define one or more Session Managers and have each one manage the sessions for a particular group or company.

**Note**

Session record size is limited by the operating system (OS) paging size (8 KB in Solaris and 4 KB in Linux). If a request triggers creation of a session that exceeds the OS paging size, the request will be dropped and the session will not be created.

**Note**

In this release of Cisco Prime AR, the memory capacity is enhanced to store more than 4 million active session's by storing the active session records in database server instead of storing it in the main memory. The capacity is dependent on the number of attributes that are being captured for each session.

**Note**

If the disk partition where Cisco Prime AR stores session backing store data (usually the disk partition where Cisco Prime AR is installed, such as **/opt/CSCOar**) is full, the subsequent packets that try to create sessions will be dropped and no sessions will be created due to lack of disk space.

Session Managers use Resource Managers, which in turn, manage a pool of resources of a particular type.

Table 3-38 lists and describes the fields in the Session Manager Details page.

Table 3-38 Session Manager Properties

Fields	Description
Name	Required; must be unique in the Session Managers list.
Description	Optional description of the Session Manager.
Type	Required; set to local or remote. Local is the traditional session manager that maintains sessions in memory and has good performance. The remote session manager operates on a remote ODBC database, and its performance is highly dependent on the performance of the ODBC database.
SessionKey	<p>SessionKey property is used to set the sessionkey value for the Session Manager.</p> <p>The SessionManager checks whether the environmental variable Session-Key is set or not. If the environmental variable is set, the server uses it as the sessionkey. If environmental variable Session-Key is not set then SessionManager gets the value configured in the SessionKey property under SessionManager.</p> <p>SessionKey can be a combination of attributes separated by colon. The values for those attributes are obtained from the RequestDictionary. If any one of the attribute that is configured for the sessionkey is not present in the RequestDictionary, Cisco Prime AR will drop the request.</p> <p>However, if Session-Key is not set, SessionManager uses NAS-Identifier and NAS-Port to create the sessionkey. An example configuration,</p> <pre>--> set SessionKey "User-Name:NAS-Port"</pre> <p>The following shows the sample configuration of sessionkey for Session Manager:</p> <pre>[//localhost/Radius/SessionManagers/session-mgr-1] Name = session-mgr-1 Description = IncomingScript = OutgoingScript = AllowAccountingStartToCreateSession = TRUE SessionTimeOut = PhantomSessionTimeOut = SessionKey = ResourceManagers/</pre>
AllowAccountingStartToCreateSession	<p>Set to TRUE by default; start the session when the Cisco Prime AR server receives an Access Accept or an Accounting-Start.</p> <p>When set to FALSE, start the session when the Cisco Prime AR server receives an Access Accept.</p>
IncomingScript	Optional; name of script to run when the service starts. This script is run as soon as the session is acquired in Cisco Prime AR.
OutgoingScript	Optional; script to be run just before the session is written to backing store.

Table 3-38 Session Manager Properties (continued)

Fields	Description
SessionTimeOut	<p>The SessionTimeOut property is optional; no value for this property means the session timeout feature is disabled.</p> <p>Used in conjunction with /Radius/Advanced/SessionPurgeInterval for the session timeout feature. Enables the session timeout feature for a Session Manager. If the SessionTimeOut property is set to a value under a session manager, all sessions that belong to that session manager will be checked for timeouts at each SessionPurgeInterval. If any sessions have timed out, they will be released, and all resources associated with those sessions are also released.</p> <p>The SessionTimeOut property determines the timeout for a session. If the time difference between the current time and the last update time is greater than this property's value, the session is considered to be stale. The last update time of the session is the time at which the session was created or updated.</p> <p>The SessionTimeOut value is comprised of a number and a units indicator, as in <i>n units</i>, where a unit is one of minutes, hours, days, or weeks. The default unit is 'days'.</p>
PhantomSessionTimeOut	<p>Optional; no value for this property means the phantom session timeout feature is disabled.</p> <p>The PhantomSessionTimeOut property is used in conjunction with /Radius/Advanced/SessionPurgeInterval to enable the phantom session timeout feature for Session Manager.</p> <p>If the PhantomSessionTimeOut property is set to a value under a session manager, all sessions that belong to that session manager will be checked for receipt of an Accounting-Start packet. Sessions that do not receive an Accounting-Start packet from creation until its timeout will be released.</p> <p>The PhantomSessionTimeOut value comprises a number and a units indicator, as in <i>n units</i>, where a unit is one of minutes, hours, days, or weeks. The default unit is 'days'.</p>
Resource Managers List	<p>Ordered list of Resource Managers. To navigate between the listed attributes, use the navigation option available adjacent to the list. See Relocating Records for more details.</p>
MemoryLimitForRadiusProcess	<p>This property is used to avoid crashing of the radius process. The default value is 3500 Megabytes. This property is under /radius/advanced. When the radius process uses memory more than the configured limit, further sessions are not created and Cisco Prime AR rejects further incoming requests.</p>
MemorySizeCheckInterval	<p>This property is used to avoid crashing of the radius process. This is used in conjunction with MemoryLimitForRadiusProcess. The default value is 5 minutes. MemorySizeCheckInterval is a hidden parameter in mcd database. To modify the default value, you need to export the mcd database. Typically, a separate thread is created to monitor the radius process memory usage for every 5 minutes.</p>

Use the Session Managers page for the following:

- [Filtering Records](#)
- [Adding Session Manager Details](#)
- [Editing Records](#)
- [Deleting Records](#)

Adding Session Manager Details

To add new session manager details:

-
- Step 1** Choose **Configuration > Session Managers**. The Session Managers page is displayed.
 - Step 2** Click **Add**. The Session Manager Details page is displayed.
 - Step 3** Enter the required details.
 - Step 4** Click **Add** to save the specified details in the Session Manager Details page. Otherwise click **Cancel** to return to the Session Managers page without saving the details.

The Session Managers page is displayed with the newly added details or a respective error message is displayed.

Resource Manager

Resource Managers allow you to allocate dynamic resources to user sessions. The following lists the different types of Resource Managers.

- **IP-Dynamic**—manages a pool of IP addresses that allows you to dynamically allocate IP addresses from a pool of addresses
- **IP-Per-NAS-Port**—allows you to associate ports to specific IP addresses, and thus ensure each NAS port always gets the same IP address
- **IPX-Dynamic**—manages a pool of IPX network addresses
- **Subnet-Dynamic**—manages a pool of subnet addresses
- **Group-Session-Limit**—manages concurrent sessions for a group of users; that is, it keeps track of how many sessions are active and denies new sessions after the configured limit has been reached
- **User-Session-Limit**—manages per-user concurrent sessions; that is, it keeps track of how many sessions each user has and denies the user a new session after the configured limit has been reached
- **Home-Agent**—manages a pool of on-demand IP addresses
- **USR-VPN**—manages Virtual Private Networks (VPNs) that use USR NAS Clients.
- **Home-Agent-IPv6**—manages a pool of on-demand IPv6 addresses
- **Remote-IP-Dynamic**—manages a pool of IP addresses that allows you to dynamically allocate IP addresses from a pool of addresses. It internally works with a remote ODBC database.

- **Remote-User-Session-Limit**—manages per-user concurrent sessions; that is, it keeps track of how many sessions each user has and denies the user a new session after the configured limit has been reached. It internally works with a remote ODBC database.
- **Remote-Group-Session-Limit**—manages concurrent sessions for a group of users; that is, it keeps track of how many sessions are active and denies new sessions after the configured limit has been reached. It internally works with a remote ODBC database.
- **Session Cache**—allows you to define the RADIUS attributes to store in cache.
- **Dynamic-DNS**—manages the DNS server.
- **Remote-Session-Cache**—allows you to define the RADIUS attributes to store in cache. It should be used with session manager of type 'remote'.

Each Resource Manager is responsible for examining the request and deciding whether to allocate a resource for the user, do nothing, or cause Cisco Prime AR to reject the request.

Table 3-39 lists and describes the fields in the Resource Manager Details page.

Table 3-39 Resource Manager Properties

Fields	Description
Resource Manager Name	Required; must be unique in the Resource Managers list.
Description (optional)	Optional; description of the Resource Manager.
Type	Required; must be either Dynamic-DNS , IP-Dynamic , IP-Per-NAS-Port , IPX-Dynamic , Session Cache , Subnet-Dynamic , Group-Session-Limit , Home-Agent , User-Session-Limit , USR-VPN , Home-Agent-IPv6 , Remote-IP-Dynamic , Remote-User-Session-Limit , Remote-Group-Session-Limit or Remote-Session-Cache . Based on the option selected, the fields displayed in the Resource Manager Details page varies.

The fields displayed in the Resource Manager Details page changes based on the option selected in the Type field. The following tables describe the fields in the Resource Manager Details page.

DYNAMIC-DNS

Table 3-40 lists and describes the fields in the Resource Manager Details page.

Table 3-40 DYNAMIC-DNS Properties

Fields	Description
General tab	
Max DNS TTLS	Set the maximum TTL of the DNS record.
DNS Host bytes	Set the number of bytes to be used to construct the reverse zone entry.
Forward Zone Name	Set the name of the forward zone. For a given Resource Manager you must decide which forward zone you will be updating for sessions the resource manager will manage.
Reverse Zone Name	Set the name of the reverse zone.
Forward Zone Server	Set the Server IP of the forward zone
Reverse Zone Server	Set the Server IP of the reverse zone

Table 3-40 *DYNAMIC-DNS Properties (continued)*

Fields	Description
Forward Zone TSIG KeyS	Server-wide security key to process all forward zone dynamic DNS updates. This is used if a ForwardZoneTSIGKey was not specified on the Resource Manager.
Reverse Zone TSIG Keys	Server-wide security key to process all reverse zone dynamic DNS updates. This is used if a ReverseZoneTSIGKey was not specified on the Resource Manager

GROUP-SESSION-LIMIT

[Table 3-41](#) lists and describes the fields in the Resource Manager Details page.

Table 3-41 *GROUP-SESSION-LIMIT Properties*

Fields	Description
Group Session Limit	Set the GroupSessionLimit property to the maximum number of concurrent sessions for all users.

REMOTE-GROUP-SESSION-LIMIT

[Table 3-42](#) lists and describes the fields in the Resource Manager Details page.

Table 3-42 *REMOTE-GROUP-SESSION-LIMIT Properties*

Fields	Description
Group Session Limit	Set the GroupSessionLimit property to the maximum number of concurrent sessions for all users.

HOME-AGENT

[Table 3-43](#) lists and describes the fields in the Resource Manager Details page.

Table 3-43 *HOME-AGENT Properties*

Fields	Description
HomeAgentIPAddresses tab	
Start	Required; must be an IP address.
End	Required; must be an IP address.

Click the **Add** button to save the details and list it in Start and End IP list. To navigate between the listed attributes, use the navigation option available adjacent to the list. See [Relocating Records](#) for more details. To delete the available attributes, select the relevant attribute and click the **Delete** button below.

HOME-AGENT-IPv6

[Table 3-44](#) lists and describes the fields in the Resource Manager Details page.

Table 3-44 HOME-AGENT-IPv6 Properties

Fields	Description
HomeAgentIPv6Addresses tab	
Start	Required; must be an IPv6 address.
End	Required; must be an IPv6 address.

Click the **Add** button to save the details and list it in Start and End IPv6 list. To navigate between the listed attributes, use the navigation option available adjacent to the list. See [Relocating Records](#) for more details. To delete the available attributes, select the relevant attribute and click the **Delete** button below.

IP-DYNAMIC

[Table 3-45](#) lists and describes the fields in the Resource Manager Details page.

Table 3-45 IP-DYNAMIC Properties

Fields	Description
General tab	
Reuse IP for same SessionKey and User	When set to TRUE, this property supports overlapping IP addresses between session managers for VPN users. Default value is FALSE.
Net Mask	Required; must be set to a valid net mask.
Allow Overlapped IP Addresses	When set to TRUE, this property supports overlapping IP addresses between session managers for VPN users. Default value is FALSE.
IP Addresses tab	
Start	Required; must be an IP address.
End	Required; must be an IP address.

Click the **Add** button to save the details and list it in Start and End IP list. To navigate between the listed attributes, use the navigation option available adjacent to the list. See [Relocating Records](#) for more details. To delete the available attributes, select the relevant attribute and click the **Delete** button below.

REMOTE-IP-DYNAMIC

[Table 3-46](#) lists and describes the fields in the Resource Manager Details page.

Table 3-46 REMOTE-IP-DYNAMIC Properties

Fields	Description
General tab	
Reuse IP for same SessionKey and User	When set to TRUE, this property supports overlapping IP addresses between session managers for VPN users. Default value is FALSE.
Net Mask	Required; must be set to a valid net mask.
Allow Overlapped IP Addresses	When set to TRUE, this property supports overlapping IP addresses between session managers for VPN users. Default value is FALSE.
IP Addresses tab	

Table 3-46 *REMOTE-IP-DYNAMIC Properties (continued)*

Fields	Description
Start	Required; must be an IP address.
End	Required; must be an IP address.

Click the **Add** button to save the details and list it in Start and End IP list. To navigate between the listed attributes, use the navigation option available adjacent to the list. See [Relocating Records](#) for more details. To delete the available attributes, select the relevant attribute and click the **Delete** button below.

IP-PER-NAS-PORT

[Table 3-47](#) lists and describes the fields in the Resource Manager Details page.

Table 3-47 *IP-PER-NAS-PORT Properties*

Fields	Description
General tab	
Net Mask	Required; if used, must be set to a valid net mask.
Allow Overlapped IP Addresses	When set to TRUE, this property supports overlapping IP addresses between session managers for VPN users. Default value is FALSE.
NAS	Required; must be the name of a known Client. This value must be the same as the NAS-Identifier attribute in the Access-Request packet.
IP Config tab	
Start	Required; must be an IP address.
End	Required; must be an IP address.
Port Config tab	
Start	Required; set the NAS port
End	Required; set the NAS port

Click the **Add** button to save the details and list it in Start and End IP list. To navigate between the listed attributes, use the navigation option available adjacent to the list. See [Relocating Records](#) for more details. To delete the available attributes, select the relevant attribute and click the **Delete** button below.

IPX-DYNAMIC

[Table 3-48](#) lists and describes the fields in the Resource Manager Details page.

Table 3-48 *IPX-DYNAMIC Properties*

Fields	Description
Networks tab	
Start	Required; must be an IP address.
End	Required; must be an IP address.

Click the **Add** button to save the details and list it in Start and End IP list. To navigate between the listed attributes, use the navigation option available adjacent to the list. See [Relocating Records](#) for more details. To delete the available attributes, select the relevant attribute and click the **Delete** button below.

SESSION-CACHE

[Table 3-49](#) lists and describes the fields in the Resource Manager Details page.

Table 3-49 *SESSION-CACHE Properties*

Fields	Description
General tab	
Overwrite Attributes	Specifies whether to overwrite the existing attributes if there are any in the session record.
Query Key	Required; set the QueryKey to the a RADIUS attribute you want to key on, such as Framed-IP-Address. A change made in Cisco Prime AR requires that this attribute not be an XML attribute, even if this session-cache resource manager is being used for an XML query. Note Any existing session-cache resource managers using an XML attribute for the Query Key must be changed to a RADIUS attribute that this XML attribute is mapped to under Query-Mappings.
Pending Removal Delay	Required; length of time information remains in the cache after the session ends (defaults to 10 seconds)
Query Mapping tab	
XML Attribute	Set the QueryKey property to the XML attribute you want to key on such as XML-Address-format-IPv4 and list all attributes to be cached in the AttributesToBeCached subdirectory.
Radius Attribute	Required; list of attribute pairs, mapping the XML attributes on the left-hand side to the RADIUS attribute on the right-hand side.
AttributeToBeCached tab	
RADIUS	Optional; set Radius, if the attribute needs to be defined for Radius.
VENDOR	Optional; set Vendor, if the attribute needs to be defined for Vendor. If Vendor is selected, specify the vendor type from the drop-down list.
Attribute Name	Required; use this subdirectory to provide a list of RADIUS attributes you want to store in cache

Click the **Add** button to save the details and list it in Start and End IP list. To navigate between the listed attributes, use the navigation option available adjacent to the list. See [Relocating Records](#) for more details. To delete the available attributes, select the relevant attribute and click the **Delete** button below.

SUBNET-DYNAMIC

[Table 3-50](#) lists and describes the fields in the Resource Manager Details page.

Table 3-50 *SUBNET-DYNAMIC Properties*

Fields	Description
Subnet Dynamic tab	
Net Mask	Required; must be set to the size of the managed subnets
Start	Required; must be an IP addresses
End	Required; must be an IP addresses

Click the **Add** button to save the details and list it in Start and End IP list. To navigate between the listed attributes, use the navigation option available adjacent to the list. See [Relocating Records](#) for more details. To delete the available attributes, select the relevant attribute and click the **Delete** button below.

USER-SESSION-LIMIT

[Table 3-51](#) lists and describes the fields in the Resource Manager Details page.

Table 3-51 *USER-SESSION-LIMIT Properties*

Fields	Description
User Session Limit	Set the user session limit property to the maximum number of concurrent sessions for a particular user

REMOTE-USER-SESSION-LIMIT

[Table 3-52](#) lists and describes the fields in the Resource Manager Details page.

Table 3-52 *REMOTE-USER-SESSION-LIMIT Properties*

Fields	Description
User Session Limit	Set the user session limit property to the maximum number of concurrent sessions for a particular user

USR-VPN

[Table 3-53](#) lists and describes the fields in the Resource Manager Details page.

Table 3-53 *USR-VPN Properties*

Fields	Description
General tab	
Identifier	Required; must be set to the VPN ID the USR NAS will use to identify a VPN.
Neighbor	Optional; if set, should be the IP address of the next hop router for the VPN.
Framed Routing	Optional; if set, should be RIP V2 Off or RIP V2 On if the USR NAS is to run RIP Version 2 for the user.
Gateway tab	
Name of Gateway	Required; name of the gateway.

Table 3-53 *USR-VPN Properties (continued)*

Fields	Description
Description (optional)	Optional; description of the gateway.
IP Address	Required; IP address of the gateway
Shared Secret	Required; must match the shared secret of the gateway.
Tunnel Refresh	Optional; if specified it is the number of seconds the tunnel stays active before a secure “keepalive” is exchanged between the tunnel peers in order to maintain the tunnel open.
Location ID	Optional; if specified it is a string indicating the physical location of the gateway. Click the Save button, to save the details.

To edit the gateway details, check the appropriate check box and click the **Edit** button. Enter new information in the editable fields and click the **Save** button. You can also delete the record using **Delete** button.

REMOTE-SESSION-CACHE

Table 3-54 lists and describes the fields in the Resource Manager Details page.

Table 3-54 *REMOTE-SESSION-CACHE Properties*

Fields	Description
General tab	
Overwrite Attributes	Specifies whether to overwrite the existing attributes if there are any in the session record.
Query Key	Required; set the QueryKey to the a RADIUS attribute you want to key on, such as Framed-IP-Address. A change made in Cisco Prime AR requires that this attribute not be an XML attribute, even if this session-cache resource manager is being used for an XML query. Note Any existing session-cache resource managers using an XML attribute for the Query Key must be changed to a RADIUS attribute that this XML attribute is mapped to under Query-Mappings.
Pending Removal Delay	Required; length of time information remains in the cache after the session ends (defaults to 10 seconds)
Remote Query Mapping tab	
XML Attribute	Set the QueryKey property to the XML attribute you want to key on such as XML-Address-format-IPv4 and list all attributes to be cached in the AttributesToBeCached subdirectory.
Radius Attribute	Required; list of attribute pairs, mapping the XML attributes on the left-hand side to the RADIUS attribute on the right-hand side.
RemoteAttributeToBeCached tab	
RADIUS	Optional; set Radius, if the attribute needs to be defined for Radius.

Table 3-54 REMOTE-SESSION-CACHE Properties (continued)

Fields	Description
VENDOR	Optional; set Vendor, if the attribute needs to be defined for Vendor. If Vendor is selected, specify the vendor type from the drop-down list.
Attribute Name	Required; use this subdirectory to provide a list of RADIUS attributes you want to store in cache

Use the Resource Manager List page for the following:

- [Filtering Records](#)
- [Adding Resource Manager Details](#)
- [Network Resources](#)
- [Editing Records](#)
- [Deleting Records](#)

Adding Resource Manager Details

To add new resource manager details:

-
- Step 1** Choose **Configuration > Resource Manager**. The Resource Manager List page is displayed.
- Step 2** Click **Add**. The Resource Manager Details page is displayed.
- Step 3** Enter the required details.
- Step 4** Click **Submit** to save the specified details in the Resource Manager Details page. Otherwise click **Cancel** to return to the Resource Manager List page without saving the details.

The Resource Manager List page is displayed with the newly added details or a respective error message is displayed.



Note

Resource Manager supports the following remote type session managers: remote-ip-dynamic, remote-session-cache, home-agent, remote-user-session-limit, home-agent-ipv6 and remote-group-session-limit.

Network Resources

Network Resources constitutes the maintenance and management of the details of the clients and remote servers. The clients IP address and shared secret details are maintained under clients, The management of server directory with use of remote server protocols details are maintained in remote server.

This section describes the following:

- [Clients](#)
- [Remote Servers](#)

Clients

All NASs and proxy clients that communicate directly with Cisco Prime AR must have an entry in the Clients list. This is required because NAS and proxy clients share a secret with the RADIUS server which is used to encrypt passwords and to sign responses.

[Table 3-55](#) lists and describes the fields in the Client Details page.

Table 3-55 *Client Properties*

Fields	Description
Name	Required and should match the Client identifier specified in the standard RADIUS attribute, NAS-Identifier . The name must be unique within the Clients list.
IncomingScript	Optional; you can use this property to specify a Script you can use to determine the services to use for authentication, authorization, and/or accounting.
OutgoingScript	Optional; you can use this property to specify a Script you can use to make any Client-specific modifications when responding to a particular Client.
Protocol	Required; set it to Radius, Diameter, or Tacacs-and-Radius .
Description	Optional description of the client.
Vendor	Optional; displays when the protocol is set to Diameter. When set, must be the name of a known Vendor.
Server Identity	Optional; displays when the protocol is set to Diameter. While exchanging the CER information in the client, Cisco Prime AR sends the configured server identity value as the origin-host value. When set, it takes precedence over the /Radius/Advance/Diameter/TransportManagement configuration.
HostName	Required; hostname or IP address of the diameter client.
Port	Required; port on which client connects with the Cisco Prime AR server.
SCTP-Enabled	Required; displays when the protocol is set to Diameter and indicates whether the connection will be an SCTP. If set to TRUE , SCTP will be used. If set to FALSE, TCP will be used.

Table 3-55 Client Properties (continued)

Fields	Description
Server Realm	Optional; displays when the protocol is set to Diameter. While exchanging the CER information in the client, Cisco Prime AR sends the configured server realm value as the origin-realms value. It takes precedence over the /Radius/Advance/Diameter/TransportManagement configuration.
General Properties tab	
IPAddress	<p>Required; must be a valid IP address and unique in the Clients list. Cisco Prime AR uses this property to identify the Client that sent the request, either using the source IP address to identify the immediate sender or using the NAS-IP-Address attribute in the Request dictionary to identify the NAS sending the request through a proxy.</p> <p>When a range is configured for a Client's IPAddress property, any incoming requests whose source address belongs to the range specified, will be allowed for further processing by the server. Similarly when a wildcard (an asterisk '*' in this case) is specified, any incoming requests whose source address matches the wildcard specification will be allowed. In both the cases, the configured client properties like SharedSecret, and Vendor are used to process the requests.</p> <p>You can specify a range of IP addresses using a hyphen as in:</p> <p style="padding-left: 40px;">100.1.2.11-20</p> <p>You can use an asterisk wildcard to match all numbers in an IP address octet as in:</p> <p style="padding-left: 40px;">100.1.2.*</p> <p>You can specify an IPAddress and a subnet mask together using Classless Inter-Domain Routing (CIDR) notation as in:</p> <p style="padding-left: 40px;">100.1.2.0/24</p> <p>You can use the IPAddress property to set a base address and use the NetMask property to specify the number of clients in the subnet range.</p>
Shared Secret	Required; must match the secret configured in the Client.
Type	Required; accept the default (NAS), or set it to ATM, Proxy, or NAS+Proxy.
Vendor	Optional; you can use this property when you need special processing for a specific vendor's NAS. To use this property, you must configure a Vendor object and include a script. Cisco Prime AR provides five Scripts you can use: one for Ascend, Cisco, Cabletron, Altiga, and one for USR. You can also provide your own Script.
NetMask	<p>Specifies the subnet mask used with the network address setting configured for the IPAddress property when configuring a range of IP addresses.</p> <p>This property is not used for a single client with an IP address only. The NetMask property is used to configure multiple clients when you configure a base IP address in the IPAddress property. You can set the NetMask property for a range of 256 clients using the following example:</p> <p style="padding-left: 40px;">set NetMask 255.255.255.0</p> <p>Note If you set the NetMask property, validation will fail if you attempt to specify a subnet mask using CIDR notation with the IPAddress property (described above).</p>

Table 3-55 Client Properties (continued)

Fields	Description
Enforce Traffic Throttling	By default, the value is set to FALSE. When set to TRUE, the traffic throttling check for the packet will be executed.
Dynamic Authorization tab	
Enable Dynamic Authorization	Optional; when set to TRUE, this property enables Change of Authorization (CoA) and Packet of Disconnect (PoD) features.
Shared Secret	Located under the DynamicAuthorizationServer subdirectory, this is the shared secret used for communicating CoA and PoD packets with the client.
Port	Located under the DynamicAuthorizationServer subdirectory, the default port is 3799.
InitialTimeout	Located under the DynamicAuthorizationServer subdirectory, the default is 5000.
MaxTries	Located under the DynamicAuthorizationServer subdirectory, the default is 3.
COA Attribute	This property is found under the DynamicAuthorizationServer subdirectory and points to a group of attributes to be included in a CoA request sent to this client. These attribute groups are created and configured under the AttributeGroups subdirectory in /Radius/Advanced .
POD Attribute	This property is found under the DynamicAuthorizationServer subdirectory and points to a group of attributes to be included in a POD request sent to this client. These attribute groups are created and configured under the AttributeGroups subdirectory in /Radius/Advanced .
Notification Properties tab	
Enable Notifications	Required; the default value is FALSE and indicates the client is not capable of receiving Accounting-Stop notifications from the Cisco Prime AR server. When set to TRUE, the client can receive Accounting-Stop notifications from the Cisco Prime AR server and additional properties must be configured under a new sub-directory named NotificationProperties.
InitialTimeout	Located under the NotificationProperties subdirectory, specifies the timeout value in milliseconds the Cisco Prime AR server waits for an Accounting-Response packet before attempting a retry (sending another Accounting-Stop packet to the client). Required when EnableNotifications is set to TRUE; the default value is 5000.
Port	Located under the NotificationProperties subdirectory, specifies the port used by the Cisco Prime AR server to receive Accounting-Stop packets. Required when EnableNotifications is set to TRUE; the default value is 1813.
MaxTries	Located under the NotificationProperties subdirectory, specifies the number of times the Cisco Prime AR server sends an Accounting-Stop packet to a client. Required when EnableNotifications is set to TRUE; the default value is 3.

Table 3-55 *Client Properties (continued)*

Fields	Description
Notification-Properties	When the EnableNotifications property is set to TRUE, this subdirectory contains additional properties required to support the Query-Notify feature.
NotificationAttributeGroup	Located under the NotificationProperties subdirectory, specifies the name of an attribute group under /Radius/Advanced/AttributeGroups that contains the attributes to be included when sending an the Accounting-Stop packet to this client. Required when EnableNotifications is set to TRUE; there is no default value. You must provide the name of a valid AttributeGroup and the named AttributeGroup must contain at least one valid attribute, or validation will fail.

Use the Clients page for the following:

- [Filtering Records](#)
- [Adding Client Details](#)
- [Editing Records](#)
- [Deleting Records](#)

Adding Client Details

To add new Client details:

-
- Step 1** Choose **Network Resources > Clients**. The Clients page is displayed.
 - Step 2** Click **Add** to add new client details. The Client Details page is displayed.
 - Step 3** Enter the required details in the General Properties, Dynamic Authorization, and Notification Properties tabs.
 - Step 4** Click **Save** to save the specified details in the Client Details page. Otherwise click **Cancel** to return to the Client page without saving the details.

The Client page is displayed with the newly added details or a respective error message is displayed.

Remote Servers

You can use the RemoteServers object to specify the properties of the remote servers to which Services proxy requests.

Cisco Prime AR provides the following RemoteServer protocol types:

- [LDAP](#)
- [LDAP Accounting](#)
- [Domain Authentication](#)
- [ODBC/OCI](#)
- [ODBC/OCI-Accounting](#)

- [Others](#)

LDAP

Specify the **ldap** service type when you want to use a particular LDAP remote server for authentication and/or authorization. When using LDAP for authentication and a local database for authorization, ensure that the usernames in both locations are identical with regard to case-sensitivity.

[Table 3-56](#) lists and describes the fields in the Add LDAP-RemoteServers Details page.

Table 3-56 LDAP Server Properties

Fields	Description
LDAP Properties tab	
Name	Required; name of the LDAP server
Host Name	Required; the LDAP server's hostname or IP address.
Port	Required; defaults to port 389.
Description	Description of the LDAP server.
Timeout	Required; the default is 15. The timeout property indicates how many seconds the RADIUS server will wait for a response from the LDAP server. Note Use InitialTimeout from above as a template, except this is timeout is specified in seconds.
Reactivate Time Interval	Required; the amount of time (in milliseconds) to wait before retrying a remote server that was offline. You must specify a number greater than zero. The default is 300,000 (5 minutes).
MaxReferrals	Required; must be a number equal to or greater than zero. This property indicates how many referrals are allowed when looking up user information. When you set this property to zero, no referrals are allowed. Cisco Prime AR manages referrals by allowing the RADIUS server's administrator to indicate an LDAP "referral attribute," which might or might not appear in the user information returned from an LDAP query. When this information is returned from a query, Cisco Prime AR assumes it is a referral and initiates another query based on the referral. Referrals can also contain referrals. Note This is an LDAP v2 referral property.
Referral Attribute	Required when you have specified a MaxReferrals value. This property specifies which LDAP attribute, returned from an LDAP search, to check for referral information. Note This is an LDAP v2 referral property.
Referral Filter	Required when you have specified a MaxReferral value. This is the filter Cisco Prime AR uses when processing referrals. When checking referrals, the information Cisco Prime AR finds in the referral itself is considered to be the search path and this property provides the filter. The syntax is the same as that of the Filter property. Note This is an LDAP v2 referral property.

Table 3-56 LDAP Server Properties (continued)

Fields	Description
Bind Name	Optional; the distinguished name (dn) to use when establishing a connection between the LDAP and RADIUS servers.
Bind Password	Optional; the password associated with the BindName .
Search Path	Required; the path that indicates where in the LDAP database to start the search for user information.
Limit Outstanding Requests	Required; the default is FALSE. Cisco Prime AR uses this property in conjunction with the MaxOutstandingRequests property to tune the RADIUS server's use of the LDAP server. When you set this property to TRUE, the number of outstanding requests for this RemoteServer is limited to the value you specified in MaxOutstandingRequests . When the number of requests exceeds this number, Cisco Prime AR queues the remaining requests, and sends them as soon as the number of outstanding requests drops to this number.
User Password Attribute	Required; this specifies which LDAP field the RADIUS server should check for the user's password.
Escape Spl.Character in UserName	FALSE by default
Datasource Connections	Specifies the number of concurrent connections to the LDAP server. The default value is 8.
Use SSL	A boolean field indicating whether you want Cisco Prime AR to use SSL (Secure Socket Layer) when communicating with this RemoteServer. When you set it to TRUE, be sure to specify the CertificateDBPath field in the Advanced section, and be sure the port you specified for this RemoteServer is the SSL port used by the LDAP server.
EnableKeepAlive	Default is FALSE. This is enabled to send a TCP keepalive to keep the idle connection active.
Filter	Required; this specifies the search filter Cisco Prime AR uses when querying the LDAP server for user information. When you configure this property, use the notation "%s" to indicate where the user ID should be inserted. For example, a typical value for this property is "(uid=%s)," which means that when querying for information about user joe, use the filter uid=joe.
Max Outstanding Requests	Required when you have set the LimitOutstandingRequests to TRUE. The number you specify, which must be greater than zero, determines the maximum number of outstanding requests allowed for this remote server.
Password Encryption Style	The default is None . You can also specify crypt , dynamic , SHA-1 , and SSHA-1 .
DNSLookup and LDAP RebindInterval	Specifies the timeout period after which the Cisco Prime AR server will attempt to resolve the LDAP hostname to IP address (DNS resolution); 0 by default

Table 3-56 LDAP Server Properties (continued)

Fields	Description
Search Scope	Specifies how deep to search within a search path; default is <i>SubTree</i> which indicates a search of the base object and the entire subtree of which the base object distinguished name is the highest object. <i>Base</i> indicates a search of the base object only. <i>OneLevel</i> indicates a search of objects immediately subordinate to the base object, but does not include the base object.
Use Binary Password Comparison	A boolean field that enables binary password comparison for authentication. This property when set to TRUE, enables binary password comparison. By default, this property is set to FALSE.
Use Bind Based Authentication	A boolean field that enables bind-based authentication with LDAP server. By default, this property is set to FALSE. When set to FALSE, it uses existing legacy authentication method. On setting this property to TRUE, the mappings LDAPToRadius, LDAP-ToEnvironment, and LDAPToCheckItem will not work.
LDAPToRadiusMappings tab	
LDAPAttribute	Set the value for the LDAP attribute
RadiusAttribute	A list of name/value pairs in which the name is the name of the ldap attribute to retrieve from the user record, and the value is the name of the RADIUS attribute to set to the value of the ldap attribute retrieved. For example, when the LDAPToRadiusMappings has the entry: FramedIPAddress = Framed-IP-Address , the RemoteServer retrieves the FramedIPAddress attribute from the ldap user entry for the specified user, uses the value returned, and sets the Response variable Framed-IP-Address to that value. Click the Add button to save the details and list it in the attribute list. To navigate between the listed attributes, use the navigation option available adjacent to the list. See Relocating Records for more details. To delete the available attributes, select the relevant attribute and click the Delete button below.
LDAPToCheckItems Mappings tab	
Attribute Type	Select either RADIUS or VENDOR . If Vendor is selected, specify the vendor type from the drop-down list.
LDAPAttribute	Set the value for the LDAP attribute

Table 3-56 LDAP Server Properties (continued)

Fields	Description
CheckedItems	<p>A list of LDAP <i>attribute/value</i> pairs which must be present in the RADIUS access request and must match, both name and value, for the check to pass.</p> <p>For example, when the LDAPToCheckItemMappings has the entry: group = User-Group, the Access Request must contain the attribute group, and it must be set to User-Group.</p> <p>Click the Add button to save the details and list it in the attribute list. To navigate between the listed attributes, use the navigation option available adjacent to the list. See Relocating Records for more details. To delete the available attributes, select the relevant attribute and click the Delete button below.</p>
LDAPToEnvironmentalMappings tab	
LDAPAttribute	Set the value for the LDAP attribute
EnvironmentalAttribute	<p>A list of name/value pairs in which the name is the name of the ldap attribute to retrieve from the user record, and the value is the name of the Environment variable to set to the value of the ldap attribute retrieved.</p> <p>For example, when the LDAPToEnvironmentMappings has the entry: group = User-Group, the RemoteServer retrieves the group attribute from the ldap user entry for the specified user, uses the value returned, and sets the Environment variable User-Group to that value.</p> <p>Click the Add button to save the details and list it in the attribute list. To navigate between the listed attributes, use the navigation option available adjacent to the list. See Relocating Records for more details. To delete the available attributes, select the relevant attribute and click the Delete button below.</p>

Use the LDAP-RemoteServers page for the following:

- [Filtering Records](#)
- [Adding LDAP Details](#)
- [LDAP Accounting](#)
- [Editing Records](#)
- [Deleting Records](#)

Adding LDAP Details

To add new LDAP details:

-
- Step 1** Choose **Network Resources > RemoteServers > LDAP**. The LDAP-RemoteServers page is displayed.
- Step 2** Click **Add** to add LDAP details. The LDAP-RemoteServers Details page is displayed.
- Step 3** Enter the required details in the tabs.
- Step 4** Click **Save LDAP Server** to save the specified details in the LDAP-RemoteServers Details page. The LDAP-RemoteServers page is displayed with the newly added details or a respective error message is displayed. Otherwise click **Cancel** to return to the LDAP-RemoteServers page without saving the details.
-

LDAP Accounting

Previous releases of Cisco Prime AR supported accessing user data from an LDAP server, but this feature was limited to performing authentication and authorization (AA). You could only write the accounting records to local file or oracle database or proxy to another RADIUS server. Cisco Prime AR supports writing accounting records into LDAP server enabling integration between billing systems and LDAP.

[Table 3-57](#) lists and describes the fields in the LDAPAcct RemoteServer Details page.

Table 3-57 LDAP Accounting Server Properties

Fields	Description
LDAP Acct Properties tab	
Name	Name of the remote server; this property is mandatory, and there is no default.
Description	Optional description of server.
HostName	Required; the LDAP server's hostname or IP address.
Port	Required; the default value is 389. Port the LDAP server is listening on.
Timeout	Mandatory time interval (in seconds) to wait for LADP-write operation to complete; defaults to 15 seconds.
ReactivateTimerInterval	Mandatory time interval (in milliseconds) to activate an inactive server; defaults to 300000 ms.

Table 3-57 LDAP Accounting Server Properties (continued)

Fields	Description
BindName	Optional; the distinguished name (dn) to use when establishing a connection between the LDAP and RADIUS servers.
EnableKeepAlive	Required; default is FALSE. This is enabled to send a TCP keepalive to keep the idle connection active.
Delimiter	Character used to separate the values of the attributes given in AttributeList property.
LDAPEnvironmentMulti-ValueDelimiter	Optional; allows you to specify a character that separates multi-valued attribute lists when using ldap-accounting.
BindPassword	Optional; the password associated with the BindName.
DnPath	Required; the path that indicates where in the LDAP database to start the write for user information.
EntryName	Required; this specifies the write entry name Cisco Prime AR uses when inserting the LDAP server for user information. When you configure this property, use the notation "%s" to indicate where the user ID should be inserted. For example, a typical value for this property is "(uid=%s)," which means that when inserting for information about user joe, use the entry name uid=joe.
LimitOutstandingRequests	Required; the default is FALSE. Cisco Prime AR uses this property in conjunction with the MaxOutstandingRequests property to tune the RADIUS server's use of the LDAP server. When you set this property to TRUE, the number of outstanding requests for this RemoteServer is limited to the value you specified in MaxOutstandingRequests . When the number of requests exceeds this number, Cisco Prime AR queues the remaining requests, and sends them as soon as the number of outstanding requests drops to this number.
MaxOutstandingRequests	Required when you have set the LimitOutstandingRequests to TRUE. The number you specify, which must be greater than zero, determines the maximum number of outstanding requests allowed for this remote server.
ObjectClass	Required; list of object classes which are all schemas defined in LDAP server. These schemas define required attributes and allowed attributes for an entry which is inserted from Cisco Prime AR.
DNSLookup and LDAPAcct RebindInterval	Specifies the timeout period after which the Cisco Prime AR server will attempt to resolve the LDAP hostname to IP address (DNS resolution).
Escape Spl.Character in UserName	FALSE by default.
AttributeList	List of comma-separated attribute names.
Datasource Connections	Mandatory number of connections to be established; defaults to 8.
UseLocalTimeZone	Optional; the default is FALSE. It determines the timezone of accounting records TimeStamp.

Table 3-57 LDAP Accounting Server Properties (continued)

Fields	Description
UseSSL	A boolean field indicating whether you want Cisco Prime AR to use SSL (Secure Socket Layer) when communicating with this RemoteServer. When you set it to TRUE, be sure to specify the CertificateDBPath field in the Advanced section, and be sure the port you specified for this RemoteServer is the SSL port used by the LDAP server.
Attributes to Write tab	
LDAPAcctAttribute	Set the LDAP Accounting attribute.
EnvironmentalAttribute	A list of name and value pairs in which the name is the name of the data store attribute to retrieve from the user record, and the value is the name of the RADIUS attribute to set to the value of the data store attribute retrieved. The data store attributes must match those defined in the external SQL file. Click the Add button to save the details and list it in the Attributes list. To navigate between the listed attributes, use the navigation option available adjacent to the list. See Relocating Records for more details. To delete the available attributes, select the relevant attribute and click the Delete button below.

Use the LDAP Acct-RemoteServers page for the following:

- [Filtering Records](#)
- [Adding LDAP Accounting Details](#)
- [Editing Records](#)
- [Deleting Records](#)

Adding LDAP Accounting Details

To add new LDAP accounting details:

-
- Step 1** Choose **Network Resources > RemoteServers > LDAP Accounting**. The LDAPAcct-RemoteServers page is displayed.
 - Step 2** Click **Add** to add LDAP accounting details. The LDAPAcct RemoteServer Details page is displayed.
 - Step 3** Enter the required details in the tabs.
 - Step 4** Click **Save LDAP Acct Server** to save the specified details in the LDAPAcct RemoteServer Details page. Otherwise click **Cancel** to return to the LDAPAcct-RemoteServers page without saving the details.

The LDAPAcct-RemoteServers page is displayed with the newly added details or a respective error message is displayed.

Domain Authentication

The Domain Authentication service type, domain-auth, is used with a Remote Server of the same type to provide support for authentication against Windows Domain Controller/Active Directory (WDC/AD).

You can click the **Add** button in the Domain Authentication-RemoteServers page to add new domain authentication details in the Domain Authentication-RemoteServers Details page. [Table 3-58](#) lists and describes the fields in the Domain Authentication-RemoteServers Details page.

Table 3-58 Domain Authentication Server Properties

Fields	Description
General Properties tab	
Name	Required; name of the domain authentication server.
Host Name	Required; hostname or IP address of the remote server.
Port	Required; port used for communication with WDC/AD; defaults to 2004.
Default Domain	Specifies the default domain for authentication if the user does not include a domain during log in. Otherwise, authentication is performed on the local domain.
Agent Connections	Required; default is 15. Represents the total number of connections Cisco Prime AR can open with the CSRA.
Description	Optional; description of the domain authentication server.
Timeout	Required; defaults to 15.
Reactivate Time Interval	Required; default is 300,000 milliseconds. Specifies the length of time to wait before attempting to reconnect if a thread is not connected to a data source.
Workstation	Optional; if a user has this workstation property set to some value, in Active Directory, then during authentication, AD will check with the CLI workstation value of Cisco Prime AR. Only if they match authentication will succeed. If this workstation value is not set in AD, no comparison with CLI workstation field happens.
Default Usergroup	User group to be used when no mapping is found in the list of maps in the GroupMap property or when there is no hit in the groups listed in GroupMaps. The DefaultUserGroup is used to authorize users that are authenticated by this domain-auth RemoteServer.
GroupMaps tab	

Table 3-58 Domain Authentication Server Properties (continued)

Fields	Description
AR UserGroup	Select a user group from the drop-down list.
AD UserGroups	<p>A list of groups to which the user belongs in the WDC/AD mapped to an internal group in the Cisco Prime AR server. Entries are of the form:</p> <ol style="list-style-type: none">1. "InternalGroup1 = ExternalGroup1, ExternalGroup2, ..."2. "InternalGroup2 = ExternalGroup3, ExternalGroup4, ..." <p>To configure group mappings, use the following syntax:</p> <pre>set 1 "Group1 = ExternalGroup1,ExternalGroup2, ExternalGroup3"</pre> <p>Click the Add button to save the details and list it in the attribute list. To navigate between the listed attributes, use the navigation option available adjacent to the list. See Relocating Records for more details. To delete the available attributes, select the relevant attribute and click the Delete button below.</p>

Use the Domain Authentication-RemoteServers page for the following:

- [Filtering Records](#)
- [Adding Domain Authentication Details](#)
- [ODBC/OCI](#)
- [Editing Records](#)
- [Deleting Records](#)

Adding Domain Authentication Details

To add new domain authentication details:

-
- Step 1** Choose **Network Resources > RemoteServers > Domain Authentication**. The Domain Authentication-RemoteServers page is displayed.
- Step 2** Click **Add** to add domain authentication details. The Domain Authentication-RemoteServers Details page is displayed.
- Step 3** Enter the required details in the tabs.
- Step 4** Click **Add Domain-Auth Server** to save the specified details in the Domain Authentication-RemoteServers Details page. Otherwise click **Cancel** to return to the Domain Authentication-RemoteServers page without saving the details.

The Domain Authentication-RemoteServers page is displayed with the newly added details or a respective error message is displayed.

ODBC/OCI

Specify **odbc** or **oci** when you want to use an ODBC or OCI service for authentication, authorization and accounting through an ODBC or OCI data store respectively. Use an ODBC or OCI service to authenticate and authorize an access requests by querying user information through ODBC or OCI and to insert accounting records into a data store through ODBC or OCI.



Note

The ODBC service supports MYSQL and Oracle database service and OCI supports Oracle with 10.2.0 to 11.2.0 Oracle client.

[Table 3-59](#) lists and describes the fields in the ODBC/OCI-RemoteServers Details page.

Table 3-59 ODBC/OCI Server Properties

Fields	Description
Name	Required; name of the ODBC/OCI Server.
Protocol	The type of remote server. You select the option ODBC or OCI from the dropdown list.

Table 3-59 ODBC/OCI Server Properties (continued)

Fields	Description
Datasource Connections	Required; default is 8. This represents the total number of connections Cisco Prime AR can open with the ODBC server; total number of threads Cisco Prime AR can create for the ODBC server.
ODBC Datasource Name	Required; name of the ODBCDataSource to use and must refer to one entry in the list of ODBC datasources configured under /Radius/Advanced/ODBCDataSources .
User Password Attribute	Set the user password.
SNMPTrapIP	The SNMP trap IP for the remote servers.
Description	Description of the ODBC Server
Timeout	Required; the default is 15. The timeout property indicates how many seconds the RADIUS server will wait for a response from the ODBC server. Note Use InitialTimeout from above as a template, except this is timeout is specified in seconds.
Reactivate Time Interval	Required; default is 300,000 milliseconds. Length of time to wait before attempting to reconnect if a thread is not connected to a data source.
Keep Alive Timer Interval	Mandatory time interval (in milliseconds) to send a keepalive to keep the idle connection active; defaults to zero (0) meaning the option is disabled
SNMPTrapPort	The SNMP trap port for the remote server; defaults to 1521.
SQL Definitions tab	
Name	SQLDefinition properties define the SQL you want to execute.
Description	Description of the SQL
Type	Cisco Prime AR supports only type query .
SQL	SQL query used to add, update or delete a record from a database
Execution SequenceNumber	Sequence number for SQLStatement execution, must be greater than zero (mandatory, no default)
Marker List	Defines all markers for the query. MarkerList uses the format UserName/SQL_DATA_TYPE.
RadiusMappings tab	
ODBC/OCI Attribute	Set the ODBC or OCI attribute

Table 3-59 ODBC/OCI Server Properties (continued)

Fields	Description
RADIUS Attribute	<p>A list of name and value pairs in which the name is the name of the data store attribute to retrieve from the user record, and the value is the name of the RADIUS attribute to set to the value of the data store attribute retrieved. The data store attributes must match those defined in the external SQL file.</p> <p>Click the Add button to save the details and list it in the Attributes list. To navigate between the listed attributes, use the navigation option available adjacent to the list. See Relocating Records for more details. To delete the available attributes, select the relevant attribute and click the Delete button below.</p>
CheckItemsMappings tab	
Attribute Type	Select either RADIUS or VENDOR . If Vendor is selected, specify the vendor type from the drop-down list.
ODBC/OCI Attribute	Set the ODBC or OCI attribute
CheckItem	<p>A list of ODBC attribute/value pairs.</p> <p>Click the Add button to save the details and list it in the Attributes list. To navigate between the listed attributes, use the navigation option available adjacent to the list. See Relocating Records for more details. To delete the available attributes, select the relevant attribute and click the Delete button below.</p>
EnvironmentalMappings tab	
ODBC/OCI Attribute	Set the ODBC or OCI attribute
Environmental Attribute	<p>A list of name/value pairs in which the name is the name of the data store attribute to retrieve from the user record, and the value is the name of the Environment variable to set to the value of the ODBC attribute retrieved.</p> <p>Click the Add button to save the details and list it in the Attributes list. To navigate between the listed attributes, use the navigation option available adjacent to the list. See Relocating Records for more details. To delete the available attributes, select the relevant attribute and click the Delete button below.</p>

Use the ODBC/OCI-RemoteServers page for the following:

- [Filtering Records](#)
- [Adding ODBC/OCI Details](#)
- [ODBC/OCI-Accounting](#)
- [Editing Records](#)
- [Deleting Records](#)

Adding ODBC/OCI Details

To add new ODBC or OCI details:

-
- Step 1** Choose **Network Resources > RemoteServers > ODBC/OCI**. The ODBC/OCI-RemoteServers page is displayed.
- Step 2** Click **Add** to add ODBC or OCI details. The ODBC/OCI-RemoteServers Details page is displayed.
- Step 3** Enter the required details.
- Step 4** Click **Add** to enter the SQL details in the **SQL Definitions** tab.
- Step 5** Click **Save** to save the specified details in the **SQL Definitions** tab or click **Cancel** to cancel the action.
- Step 6** Enter the required details in the tabs.
- Step 7** Click **Add Server** to save the specified details in the ODBC/OCI-RemoteServers Details page. Otherwise click **Cancel** to return to the ODBC/OCI-RemoteServers page without saving the details. The ODBC/OCI-RemoteServers page is displayed with the newly added details or a respective error message is displayed.
-

ODBC/OCI-Accounting

If you use the Oracle Accounting feature, you must configure an ODBC/OCI-Accounting RemoteServer object.

[Table 3-60](#) lists and describes the fields in the Add ODBC/OCI Accounting-RemoteServers page.

Table 3-60 ODBC/OCI Accounting Server Properties

Fields	Description
General Properties tab	
Name	Name of the remote server; this property is mandatory, and there is no default.
Protocol	The type of Accounting remote server. You can select the option <code>odbc-accounting</code> or <code>oci-accounting</code> from the drop-down list.
Datasource Connections	Mandatory number of connections to be established; defaults to 8
ODBC Datasource Name	Name of the ODBCDataSource to use and must refer to one entry in the list of ODBC datasources configured under /Radius/Advanced/ODBCDataSources . Mandatory; no default
Buffer Accounting Packets	Mandatory, TRUE or FALSE, determines whether to buffer the accounting packets to local file, defaults to TRUE which means that packet buffering is enabled. Note When set to TRUE, a constant flow of incoming accounting packets can fill the buffer backing store files in /cisco-ar/data/odbc beyond the size configured in <code>MaximumBufferSize</code> . Configure <code>BackingStoreDiscThreshold</code> in /Radius/Advanced when using ODBC accounting.
Max. Buffer Filesize	Mandatory if <code>BufferAccountingPackets</code> is set to TRUE, determines the maximum buffer file size, defaults to 10 Megabyte)

Table 3-60 ODBC/OCI Accounting Server Properties (continued)

Fields	Description
Backing Store Environment Variables	Optional; when BufferAccountingPackets is set to TRUE, contains a comma-separated list of environment variable names to be stored into a local file along with buffered packet. No default. Backing-StoreEnvironmentVariables can also be specified in scripts using the BackingStoreEnvironmentVariables environment variable.
Attribute List	List of comma-separated attribute names.
SNMPTrapIP	Optional; when set to a valid IP address, the traps (responding/not responding traps) for the ODBC/OCI Accounting server will have this IP address. This is used to identify the server. If the value is not set, SNMP traps use 255.255.255.255 as the IP address.
Description	Optional; description of server.
Timeout	Mandatory time interval (in seconds) to wait for SQL operation to complete; defaults to 15 seconds.
Reactivate Time Interval	Mandatory time interval (in milliseconds) to activate an inactive server; defaults to 300000 ms.
Keep Alive Timer Interval	Mandatory time interval (in milliseconds) to send a keepalive to keep the idle connection active; defaults to zero (0) meaning the option is disabled.
No. of Retries for Buffered Packet	Mandatory if BufferAccountingPackets is set to TRUE. A number greater than zero determines the number of attempts to be made to insert the buffered packet into Oracle. Defaults to 3.
Use Local Timezone	Set to TRUE or FALSE, determines the timezone of accounting records' TimeStamp (defaults to FALSE).
Delimiter	Character used to separate the values of the attributes given in AttributeList property.
SNMPTrapPort	Optional; when set to a valid port, the traps (responding/not responding traps) for the ODBC/OCI Accounting server will have this port. If the value is not set, SNMP traps use 1521 as the IP port.
SQL Definitions tab	
Name	Required; SQLDefinition properties define the SQL you want to execute.
Description	Description of the SQL
Type	Required; Cisco Prime AR supports insert, update and delete options.
SQL	Required; SQL query used to acquire the password
Execution SequenceNumber	Required; sequence number for SQLStatement execution, must be greater than zero (mandatory, no default)
Marker List	Required; defines all markers for the query. MarkerList uses the format UserName/SQL_DATA_TYPE.

Use the ODBC/OCI Accounting-RemoteServers page for the following:

- [Filtering Records](#)
- [Adding ODBC/OCI Accounting Details](#)
- [Others](#)
- [Editing Records](#)
- [Deleting Records](#)

Adding ODBC/OCI Accounting Details

To add new ODBC or OCI accounting details:

-
- Step 1** Choose **Network Resources > RemoteServers > ODBC/OCI Accounting**. The ODBC/OCI Accounting-RemoteServers page is displayed.
- Step 2** Click **Add** to add ODBC or OCI accounting details. The ODBC/OCI Accounting-RemoteServers Details page is displayed.
- Step 3** Enter the required details in the tabs.
- Step 4** Click **Add Accounting Server** to save the specified details in the ODBC/OCI Accounting-RemoteServers Details page. The ODBC/OCI Accounting-RemoteServers page is displayed with the newly added details or a respective error message is displayed. Otherwise click **Cancel** to return to the ODBC/OCI Accounting-RemoteServers page without saving the details.
-

Others

This feature of GUI allows you to set other specifications. The various types of protocols are:

- Radius
- Dynamic DNS
- Map-Gateway
- Prepaid-CRB
- Prepaid IS 835C
- Sigtran
- Sigtran-m3ua

[Table 3-61](#) lists and describes the fields in the Remote Server Details page. The fields listed below are the entire list of all the available protocols. The fields are displayed based on the type of protocol selected.

Table 3-61 *Other Server Properties*

Fields	Description
Name	Required; name of the server.
Description	Optional; description of the server.

Table 3-61 Other Server Properties (continued)

Fields	Description
Protocol	Required; the port to which Cisco Prime AR sends proxy requests. You must specify a number greater than zero. If there is no default port number, you must supply the correct port number for your remote server. If you set a port to zero, Cisco Prime AR sets the port to the default value for the type of remote server being configured.
IP Address	Required; this property specifies where to send the proxy request. It is the address of the remote server. You must set it to a valid IP address.
Port	By default, Cisco Prime AR listens on ports 1645.
ReactivateTimerInterval	Mandatory time interval (in milliseconds) to activate an inactive server; defaults to 300000 ms.
MaxTries	Number of times the server tries to send dynamic updates to a server.
Initial Timeout	Time, in milliseconds, that the server waits for a response before retrying a request.
SharedSecret	Required; the secret shared between the remote server and the RADIUS server.
Vendor	Optional; when set, must be the name of a known Vendor.
IncomingScript	Optional; when set, must be the name of a known incoming script. Cisco Prime AR runs the IncomingScript after it receives the response.
OutGoingScript	Optional; when set, must be the name of a known outgoing script. Cisco Prime AR runs the OutgoingScript just before it sends the proxy request to the remote server.
AccountingPort	Port where the RADIUS server sends accounting packets.
AcknowledgeAccounting	When ACKAccounting is TRUE, the Cisco Prime AR server waits for the Accounting-Response from the remote RADIUS server before sending the corresponding Accounting-Response to the client. When ACKAccounting is FALSE, the Cisco Prime AR server does not wait for the Accounting-Response and immediately returns an Accounting-Response to the client.
Accept Dynamic Authorization Requests	The value is set to False, by default.
MaxRename Retries	Number of times that the resource managers can try to add a host even if it detects that the host's name is already present. This controls the number of times Cisco Prime AR tries to modify a host's name to resolve a conflict on each failed update.
Trim HostName	Controls whether Cisco Prime AR trims the hostname string to the first period character. If this attribute is enabled, the hostname is truncated before the period. If disabled, the server retains the period characters in the hostname.

Table 3-61 Other Server Properties (continued)

Fields	Description
FwdZoneTSIG	Server-wide security key to process all forward zone dynamic DNS updates. This is used if a ForwardZoneTSIGKey was not specified on the Resource Manager.
ReverseZoneTSIG	Server-wide security key to process all reverse zone dynamic DNS updates. This is used if a ReverseZoneTSIGKey was not specified on the Resource Manager.
File Name	Name of the shared library provided by the billing server vendor, such as libprepaid.so
Connections	Number of threads the prepaid service and billing server can each use (default is 8).
HostName	Required; hostname of the remote server.
Local Sub System Number	Required; the default value for this property is 0. This represents the subsystem number used by SUA user.
CgPA Global Title Address	Required; represents the Global Title Address of CallingPartyAddress.
Set OPC In CgPA	Required; if it is set to TRUE, OPC will be used in CallingPartyAddress.
CdPAnumberingPlan	Required; used to specify the numbering plan of the called party. The default value is 7.
CgPAnumberingPlan	Required; used to specify the numbering plan of the calling party. The default value is 7.
Global Title Translation Script	This is used to specify the name of script which is responsible for translating IMSI to GTA.
SUA Configuration Filename	Required; used to specify the name of configuration file for SUA stack initialization.
Max Outstanding Requests	This represents the maximum outstanding request to HLR.
Timeout	Required; represents the how long the remote server should wait before marking the request as timedout.
Limit Outstanding Requests	Limits the outstanding request to HLR when it is set to TRUE.
SourceIPAddress	Required; name of the local IP address.
SourcePort	Required; specify the port number in which Cisco Prime AR is installed for M3UA transactions.
LocalSubSystemNumber	Required; the local sub system number is set as 149 by default.
DestinationPort	Required; specify the destination port number to which Cisco Prime AR connects.
IMSI Translation Script	Specify the scripting point that is used to modify the IMSI based on the requirement before sending the request to STP/HLR.
Timeout	Required; specify the time (in seconds) to wait before an authentication request times out; defaults to 120.
ReactivateTimerInterval	Required; specify the time interval (in milliseconds) to activate an inactive server; defaults to 300000 ms (which is 5 minutes).

Table 3-61 Other Server Properties (continued)



Fields	Description
Limit Outstanding Requests	<p>Cisco Prime AR uses this property in conjunction with the MaxOutstandingRequests property to tune the RADIUS server's use of the HLR. The default is FALSE.</p> <p>When you set this property to TRUE, the number of outstanding requests for this RemoteServer is limited to the value you specified in MaxOutstandingRequests. When the number of requests exceeds this number, Cisco Prime AR queues the remaining requests, and sends them as soon as the number of outstanding requests drops to this number.</p>
MaxOutstandingRequests	Required; specify the maximum number of outstanding requests allowed for this remote server.
MAP-Version	Required; specify the MAP version as 2 or 3 that HLR supports.
NetworkVariant	<p>Required; select the network variant switch.</p> <p> Note Cisco Prime AR supports only ITU value in 6.0 version.</p>
SubServiceField	Required; specify the type of network to which this SAP belongs. The possible options are INT and NAT which represents international network and national network respectively.
TCAPVariant	Required; specify the name of the tcap network variant switch. The possible options are ITU88, ITU92, or ITU96.
NetworkAppearance	Required; specify the network appearance code which ranges from 0-2147483647.
NetworkIndicator	Required; specify the network indicator used in SCCP address. The possible options are NAT and INT which represents international network and national network respectively.
RoutingIndicator	Required; specify the routing indicator. The possible options are RTE_GT or RTE_SSN which is used to route the packets for HLR.
MLCNumber	<p>Required; specify the MLC number which is required for M3UA service for fetching the MSISDN from the HLR. The MLC number is configured in E.164 format.</p> <p> Note MLC is a max-15 digit number.</p>
TrafficMode	Required; specify the traffic mode values for the HLR.
LoadShareMode	<p>Required; specify the load share mode for the HLR.</p> <p>When there is more than one associations with HLR, then the load sharing is set as Signaling Link Selection (SLS). SLS is done based on a simple round-robin basis.</p>
RoutingParameters	
OriginPointCode	Required; specify the originating point of a message in a signalling network. The value ranges from 0 - 16777215.

Table 3-61 Other Server Properties (continued)

Fields	Description
DestinationPointCode	Required; specify the destination address of a signalling point in a SS7 network.
RemoteSubSystemNumber	Required; specify the sub system number of the remote server. The RemoteSubSystemNumber is set as 6 by default.
OPCMask	Required; specify the wild card mask for the origin point code. The value ranges from 0 - 16777215.
DPCMask	Specify the wild card mask for the destination point code. The value ranges from 0 - 16777215.
ServiceIndicatorOctet	Specify the service identifier octet. The value ranges from 0 - 255.
RoutingContext	Required; specify the routing context which ranges from 0 - 16777215.

Use the RemoteServers page allows for the following:

- [Filtering Records](#)
- [Setting Other Specifications](#)
- [Editing Records](#)
- [Deleting Records](#)

Setting Other Specifications

To set up other specifications:

-
- Step 1** Select **Network Resources > RemoteServers > Others**. The RemoteServers page is displayed.
 - Step 2** Click **Add** to add other specifications. The Remote Server Details page is displayed.
 - Step 3** Enter the required details.
 - Step 4** Click **Add Radius Server** to save the specified details in the Remote Server Details page. Otherwise click **Cancel** to return to the RemoteServers page without saving the details.

The RemoteServers page is displayed with the newly added details or a respective error message is displayed.

Administration

Administration constitutes the maintenance and management of details specific administrator, various statistical data respective to the administrators, backing up and restoring server details, and license management of the server.

This section describes the following:

- [Administrators](#)

- [Statistics](#)
- [Diameter Statistics](#)
- [TACACS Statistics](#)
- [Backup and Restore](#)
- [License Upload](#)

Administrators

Cisco Prime AR provided *super-user* administrative access in which administrator can perform all tasks including starting and stopping the system and changing the configuration. Cisco Prime AR also provides view-only administrative access. View-only access restricts an administrator to only being able to observe the system and prevents that user from making changes.

[Table 3-62](#) lists and describes the fields in the Administrator Details page.

Table 3-62 Administrator Properties

Fields	Description
Name	Required; administrator's user ID.
Description	Optional; description of the administrator.
New Password	Required; encrypted password of the administrator.
Confirm New Password	Required; encrypted password of the administrator and must match Password.
View Only	Default value (FALSE) indicates that the administrator is able to modify the configuration. When set to TRUE, the administrator can only view the server configuration and set the change the server trace level.

Use the Administrators page for the following:

- [Filtering Records](#)
- [Adding Administrator Details](#)
- [Statistics](#)
- [Editing Records](#)
- [Deleting Records](#)

Adding Administrator Details

To add new Administrator details:

-
- Step 1** Choose **Administration > Administrators**. The Administrators page is displayed.
 - Step 2** Click **Add** to add administrator details. The Administrator Details page is displayed.
 - Step 3** Specify the required details.
 - Step 4** Click **Submit** to save the specified details in the Administrator Details page. Otherwise click **Cancel** to return to the Administrators page without saving the details.

The Administrators page is displayed with the newly added details or a respective error message is displayed.

Statistics

This feature provides statistical information on the specified server.

[Table 3-63](#) lists the statistics information and the meaning of the values.

Table 3-63 *aregcmd stats Information*

Stats Value	Meaning
serverStartTime	Indicates the start time of the server.
serverResetTime	Indicates the time when the server was reloaded.
serverStat	Indicates if the server is running or stopped.
totalPacketsInPool	Number of packets that can be accommodated in the pool.
totalPacketsReceived	Number of packets that are received by radius server.
totalPacketsSent	Number of packets that are sent by radius server.
totalRequests	Number of requests received by radius server. This includes access requests and accounting requests.
totalResponses	Number of responses sent by radius server. This includes access accepts/rejects and accounting responses.
totalAccessRequests	Number of access requests received/processed by radius server.
totalAccessAccepts	Number of access accepts sent by radius server.
totalAccessChallenges	Number of access challenges sent by radius server.
totalAccessRejects	Number of access rejects sent by radius server.
totalAccessResponses	Number of access responses sent by radius server.
totalAccountingRequests	Number of accounting requests received by radius server.
totalAccountingResponses	Number of accounting responses sent by radius server.

Table 3-63 *aregcmd stats Information (continued)*

Stats Value	Meaning
totalStatusServerRequests	Number of status server request received by radius server.
totalAscendIPAAAllocateRequests	Number of requests received related to Ascend IP address allocation.
totalAscendIPAAAllocateResponses	Number of responses sent related to Ascend IP Address Allocation.
totalAscendIPAReleaseRequests	Number of requests received related to Ascend IP Address release.
totalAscendIPAReleaseResponses	Number of responses sent related to Ascend IP Address release.
totalUSRNASRebootRequests	Number of user NAS reboot request received by radius server.
totalUSRNASRebootResponses	Number of user NAS reboot response sent by radius server.
totalUSRResourceFreeRequests	Number of user resource free request received by radius server.
totalUSRResourceFreeResponses	Number of user resource free response sent by radius server.
totalUSRQueryResourceRequests	Number of user query resource request received by radius server.
totalUSRQueryResourceResponses	Number of user query resource response sent by radius server.
totalUSRQueryReclaimRequests	Number of user query reclaim request received by radius server.
totalUSRQueryReclaimResponses	Number of user query reclaim response sent by radius server.
totalPacketsInUse	Number of packets that are being used.
totalPacketsDrained	Number of packets that are drained.
totalPacketsDropped	Number of packets that are dropped.
totalPayloadDecryptionFailures	Number of failures due to payloads decryption.
RemoteServer statistics for:	Provides server's type, name, IP address, and port used.
active	Indicates whether the server was active (not in a down state).
maxTries	Number of retry attempts to be made by the RemoteServer Object based on the RemoteServer's <i>maxTries</i> property setting .
RTTAverage	Average round trip time since the last server restart.
RTTDeviation	Indicates a standard deviation of the RTTAverage.

Table 3-63 *aregcmd stats Information (continued)*

Stats Value	Meaning
TimeoutPenalty	Indicates any change made to the initial timeout default value.
totalRequestsPending	Number of requests currently queued.
totalRequestsSent	Number of requests sent since the last server restart. Note totalRequestsSent should equal the sum of totalRequestsOutstanding and totalRequestsAcknowledged.
totalRequestsOutstanding	Number of requests currently proxied that have not yet returned
totalRequestsTimedOut	Number of requests that have timed out since last server restart or number requests not returned from proxy server within the [configured] initial timeout interval.
totalRequestsAcknowledged	Number of responses received since last server restart
totalResponsesDroppedForNotInCache	Number of responses dropped because their ID did not match the ID of any Pending requests.
totalResponsesDroppedForSignatureMismatch	Number of responses dropped because their response authenticator did not decode to the correct shared secret.
totalRequestsDroppedAfterMaxTries	Number of requests dropped because no response was received after retrying the configured number of times. This value is different from totalRequestsTimedOut because using the default configuration values, no response within 2000 ms bumps the TimedOut counter, but it waits 14000 ms (2000 + 4000 + 8000) to bump this counter.
lastRequestTime	Date and time of last proxy request.
lastAcceptTime	Date and time of last ACCEPT response to a client.

Resetting Server Statistics

To reset server statistics:

-
- Step 1** Choose **Administration > Statistics**. The Radius Server Statistics page is displayed.
 - Step 2** Click **Reset** to reset all the radius server statistics.
-

Diameter Statistics

Cisco Prime AR supports statistic of Diameter messages through the CLI/GUI and SNMP. The existing 'stats' module has been extended to include additional counters related to Diameter. The diameter statistics includes peer statistics and global summary statistics details on the specified server.

Table 3-64 and Table 3-65 lists the statistics information and the meaning of the values. The statistical information in Table 3-65 is displayed based on the peer selected.

Table 3-64 *Diameter stats Information*

Metric	Value
Diameter Statistics	
serverStartTime	The start time of the server.
serverResetTime	The reset time of the server.
serverState	The state of the server.
cdbpLocalStatsTotalUpTime	The total time for which the Diameter server is up.
cdbpLocalResetTime	The time elapsed since a server was reset.
cdbpLocalStatsTotalPacketsIn	The total number of packets received by a Diameter Base protocol.
cdbpLocalStatsTotalPacketsOut	The total number of packets transmitted by a Diameter Base protocol.
Peer	The name of the peer. You can select a peer from the drop-down list.

Table 3-65 *Diameter peer stats Information*

Metric	Value
Diameter Peers	
Stats for the Remote Server	The name of the selected peer.
ipaddress	The IP address of the peer.
port	The port of the peer.
cdbpPeerStatsState	Indicates the connection state in the Peer State Machine of the peer with which the Diameter server is communicating.
cdbpPeerStatsASAsOut	Number of Abort-Session-Answer messages that are sent to the peer.
cdbpPeerStatsACRsIn	Number of Accounting-Request messages that are received from the peer
cdbpPeerStatsACRsOut	Number of Accounting-Request messages that are sent to the peer.
cdbpPeerStatsACAsIn	Number of Accounting-Answer messages that are received from the peer.

Table 3-65 *Diameter peer stats Information (continued)*

Metric	Value
cdbpPeerStatsACAsOut	Number of Accounting-Answer messages that are sent to the peer.
cdbpPeerStatsCERsIn	Number of Capabilities-Exchange-Request messages received from the peer.
cdbpPeerStatsCERsOut	Number of Capabilities-Exchange-Request messages sent to the peer.
cdbpPeerStatsCEAsIn	Number of Capabilities-Exchange-Answer messages received from the peer.
cdbpPeerStatsCEAsOut	Number of Capabilities-Exchange-Answer messages sent to the peer.
cdbpPeerStatsDWRsIn	Number of Device-Watchdog-Request messages received from the peer.
cdbpPeerStatsStateDuration	Represents the Peer state duration.
cdbpPeerStatsDWRsOut	Number of Device-Watchdog-Request messages sent to the peer.
cdbpPeerStatsDWAsIn	Number of Device-Watchdog-Answer messages received from the peer.
cdbpPeerStatsDWAsOut	Number of Device-Watchdog-Answer messages sent to the peer.
cdbpPeerStatsDPRsIn	Number of Disconnect-Peer-Request messages received from the peer.
cdbpPeerStatsDPRsOut	Number of Disconnect-Peer-Request messages sent to the peer.
cdbpPeerStatsDPAsIn	Number of Disconnect-Peer-Answer messages received from the peer.
cdbpPeerStatsDPAsOut	Number of Disconnect-Peer-Answer messages sent to the peer.
cdbpPeerStatsRARsIn	Number of Re-Auth-Request messages that are received from the peer.
cdbpPeerStatsRARsOut	Number of Re-Auth-Request messages that are sent to the peer.
cdbpPeerStatsRAAsIn	Number of Re-Auth-Answer messages that are received from the peer.
cdbpPeerStatsRAAsOut	Number of Re-Auth-Answer messages that are sent to the peer.
cdbpPeerStatsSTRsIn	Number of Session-Termination-Request messages that are received from the peer.
cdbpPeerStatsSTRsOut	Number of Session-Termination-Request messages that are sent to the peer.
cdbpPeerStatsSTAsIn	Number of Session-Termination-Answer messages that are received from the peer.

Table 3-65 *Diameter peer stats Information (continued)*

Metric	Value
<code>cdbpPeerStatsSTAsOut</code>	Number of Session-Termination-Answer messages that are sent to the peer.
<code>cdbpPeerStatsDWReqTimer</code>	The interval between the packets that are sent to the peers.
<code>cdbpPeerstatsRedirectEvents</code>	Number of redirects that are sent from a peer.
<code>cdbpPeerStatsAccDupRequests</code>	Number of duplicate Diameter Accounting-Request packets.
<code>cdbpPeerStatsMalformedReqsts</code>	Number of malformed diameter packets that are received.
<code>cdbpPeerStatsAccsNotRecorded</code>	Number of Diameter Accounting-Request packets that are received and responded but not recorded.
<code>cdbpPeerStatsWhoInitDisconnect</code>	Indicates whether the host or peer initiated the disconnect.
<code>cdbpPeerStatsAccRetrans</code>	Number of Diameter Accounting-Request packets that are retransmitted to the Diameter server.
<code>cdbpPeerStatsTotalRetrans</code>	Number of diameter packets that are retransmitted to the Diameter server. This does not include the Diameter Accounting-Request packets that are retransmitted.
<code>cdbpPeerStatsAccPendReqstsOut</code>	Number of Diameter Accounting-Request packets that are sent to the peer which have not yet timed out or received a response. This variable is incremented when an Accounting-Request is sent to the server and decremented due to receipt of an Accounting-Response, a timeout or a retransmission.
<code>cdbpPeerStatsAccReqstsDropped</code>	Number of Accounting-Requests to the server that are dropped.
<code>cdbpPeerStatsHByHDropMessages</code>	An answer message that is received with an unknown hop-by-hop identifier. This does not include the accounting requests that are dropped.
<code>cdbpPeerStatsEToEDupMessages</code>	The duplicate answer messages that are locally consumed. This does not include duplicate accounting requests that are received.
<code>cdbpPeerStatsUnknownTypes</code>	Number of Diameter packets of unknown type that are received from the peer.
<code>cdbpPeerStatsProtocolErrors</code>	Number of protocol errors that are returned to peer, but not including the redirects.
<code>cdbpPeerStatsTransientFailures</code>	Indicates the transient failure count.

Table 3-65 Diameter peer stats Information (continued)

Metric	Value
cdbpPeerStatsDWCurentStatus	Indicates the connection status of the peer.
cdbpPeerStatsTransportDown	Number of unexpected transport failures.
cdbpPeerStatsTimeoutConnAtmpts	Number of times the server attempts to connect to a peer when there is no transport connection with the peer. This is reset on disconnection.
cdbpPeerStatsASRsIn	Number of Abort-Session-Request messages that are received from the peer.
cdbpPeerStatsASRsOut	Number Abort-Session-Request messages that are sent to the peer.
cdbpPeerStatsASAsIn	Number of Abort-Session-Answer messages that are received from the peer.

Select the required peer from the Client drop-down list and click the **Show Peer Stats** button to view the diameter statistics of the peer. Click the **Reset** button, to reset all the diameter statistics of the peer.

TACACS Statistics

Cisco Prime AR supports CISCO-AAA-SERVER-MIB to describe the statistics of TACACS+ protocol. This is supported through CLI/GUI and SNMP.

Table 3-66 lists the statistics information and the meaning of the values.

Table 3-66 TACACS stats Information

Metric	Value
TACACS Statistics	
serverStartTime	The start time of the server.
serverResetTime	The reset time of the server.
serverState	The state of the server.
totalPacketsReceived	Number of packets that are received by a TACACS+ protocol irrespective of the type of Authentication and Accounting.
totalPacketsSent	Number of packets that are sent by a TACACS+ protocol irrespective of the type of Authentication and Accounting.
totalRequests	Number of packet requests that are received by a TACACS+ protocol irrespective of the type of Authentication and Accounting.
totalResponses	Number of packet responses that are sent by a TACACS+ protocol irrespective of the type of Authentication and Accounting.

Table 3-66 TACACS stats Information (continued)

Metric	Value
totalAuthenticationRequests	Number of authentication requests that are received by Cisco Prime AR.
totalAuthenticationAccepts	Number of authentication requests that are accepted by Cisco Prime AR.
totalAuthenticationRejects	Number of authentication requests that are rejected by Cisco Prime AR.
totalAuthenticationChallenges	Number of authentication challenges that are faced by Cisco Prime AR.
totalAuthenticationResponses	Number of authentication responses that are sent by Cisco Prime AR.
totalAccountingRequests	Number of accounting requests that are received by Cisco Prime AR.
totalAccountingAccepts	Number of accounting requests that are accepted by Cisco Prime AR.
totalAccountingRejects	Number of accounting requests that are rejected by Cisco Prime AR.
totalAccountingResponses	Number of accounting requests that are sent by Cisco Prime AR.
totalPayloadDecryptionFailures	Number of packets that are not decrypted by Cisco Prime AR.
totalPacketsDropped	Number of packets that are dropped by Cisco Prime AR. The packets are dropped, which are invalid and do not fulfill the parsing conditions.

Backup and Restore

To backup and restore the server details, Choose **Administration > Backup & Restore**. The Backup page is displayed with the list of recently backed up details of the server with the date and time. This option allows you to take a backup of the database, sessions, and scripts, and stores it in `/cisco-ar/backup` directory.

Backup Server Details

To backup the server details:

-
- Step 1** Choose **Administration > Backup & Restore**. The Backup page is displayed.
 - Step 2** Click **Backup** to take a backup of the database, sessions, and scripts, and stores it in `/cisco-ar/backup` directory. The details will be backed up and appended to the backup list and displayed in the Backup page.
-

Restoring Server Details

To restore the backed-up server details:

-
- Step 1** Choose **Administration > Backup & Restore**. The Backup page is displayed.
 - Step 2** Choose the record from the backup list.
 - Step 3** Click **Restore**. The details of the selected back up file will be restored successfully.
-

License Upload

Cisco Prime AR license information are uploaded using the Upload feature. To upload the license file, Choose **Administration > License Upload**. The Cisco Prime AR License - Upload page appears. Click the **Browse** button, to locate the license file. The file selector dialog box appears. Choose the file. To upload the license file, click the **Upload** button. To clear the text in the field, click the **Reset** button.

Uploading License File

To upload the Cisco Prime AR license file:

-
- Step 1** Choose **Administration > License Upload**. The Cisco Prime AR License-Upload page is displayed.
 - Step 2** Click **Browse** to locate the license file. The File Upload dialog box is displayed.
 - Step 3** Choose the required file.
 - Step 4** Click **Upload**. The selected file will be uploaded in `/cisco-ar/license` directory.



Note You need to ensure that the license file that you want to upload should be in **.lic** format.

- Step 5** Click **Reset** to clear the text in the Select the File field, if you want to clear the selected path.
-

Read-Only GUI

Cisco Prime AR provides a read-only GUI that enables an administrator to observe the system but prevents that administrator from making changes.

When you configure a user to be an administrator, check the View-Only check box to limit the administrator to view-only operation. You can also use the CLI by setting the View-Only property to TRUE under /Administrator/admin_name.

When using the Read-Only GUI, the Configuration, Network Resources and Administration sections are displayed as same as a fully-enabled administrator. The details of these sections are displayed in text format and cannot be edited.



CHAPTER 4

Cisco Prime Access Registrar Server Objects

This chapter describes the objects you use to configure and operate your Cisco Prime AR RADIUS server.

Cisco Prime Access Registrar (Cisco Prime AR) is configured and operated through a set of *objects*. These objects are arranged in a hierarchy, with some of the objects containing subobjects; just as in a UNIX file system, in which directories can contain subdirectories. All of the objects, except those that are merely lists, contain properties that define the attributes or behavior of the object.

This chapter describes the following Cisco Prime AR objects:

- [Radius](#)— root of the configuration hierarchy
- [UserLists](#)—contains individual UserLists, which in turn contain users
- [UserGroups](#)—contains individual UserGroups
- [Policies](#)—contains individual Policies
- [Clients](#)—contains individual Clients
- [Vendors](#)—contains individual Vendors
- [Scripts](#)—contains individual Scripts
- [Services](#)—contains individual Services
- [Session Managers](#)—contains individual Session Managers
- [Resource Managers](#)—contains individual Resource Managers
- [Profiles](#)—contains individual Profiles
- [Rules](#)—contains individual Rules
- [Translations](#)—contains individual Translations
- [TranslationGroups](#)—contains individual Translation Groups
- [Remote Servers](#)—contains individual RemoteServers
- [Advanced](#)—contains advanced properties, Ports, Interfaces, Reply Messages, and the Attribute dictionary

Radius

The **Radius** object is the root of the hierarchy. For each installation of the Cisco Prime AR server, there is one instance of the **Radius** object. You reach all other objects in the hierarchy from the **Radius**.

The following is a listing of the RADIUS server object:

```
[ //localhost/Radius ]
  Name = Radius
  Description =
  Version = 1.7R0
  IncomingScript~ =
  OutgoingScript~ =
  DefaultAuthenticationService~ = local-users
  DefaultAuthorizationService~ = local-users
  DefaultAccountingService~ = local-file
  DefaultSessionService~ =
  DefaultSessionManager~ = session-mgr-1
  UserLists/
  UserGroups/
  Policies/
  Clients/
  Vendors/
  Scripts/
  Services/
  SessionManagers/
  ResourceManagers/
  Profiles/
  Rules/
  Translations/
  TranslationGroups/
  RemoteServers/
  Advanced/
  Replication/
```

Table 4-1 lists the **Radius** properties. You can set or change Radius properties using the Cisco Prime AR **aregcmd** commands.



Note

When a field is listed as required, it means a value must be supplied; that is, the value must be set. You can use the default (if it is supplied) or you can change it to something else, but you cannot unset it. You *must* supply values for the required fields and for which no defaults exist.

Table 4-1 Radius Properties

Property	Description
Name	Required; must be unique in the list of servers in the cluster
Description	Optional description of the server
Version	Required; the currently installed version of Cisco Prime AR
IncomingScript	Optional; if there is a script, it is the first script Cisco Prime AR runs when it receives a request from any client and/or for any service
OutgoingScript	Optional; if there is a script, it is the last script Cisco Prime AR runs before it sends a response to any client

Table 4-1 Radius Properties (continued)

Property	Description
DefaultAuthenticationService	Optional; Cisco Prime AR uses this property when none of the incoming scripts sets the environment dictionary variable Authentication-Service .
DefaultAuthorizationService	Optional; Cisco Prime AR uses this property when none of the incoming scripts sets the environment dictionary variable Authorization-Service .
DefaultAccountingService	Optional; Cisco Prime AR uses this property when none of the incoming scripts sets the environment dictionary variable Accounting-Service .
DefaultSessionService	Optional; Cisco Prime AR uses this property when none of the incoming scripts sets the environment dictionary variable Session-Service .
DefaultSessionManager	Optional; Cisco Prime AR uses this property if none of the incoming scripts sets the environment dictionary variable Session-Manager .

The remaining Cisco Prime AR objects are sub-objects of the **Radius** object.

UserLists

The **UserLists** object contains all of the individual UserLists, which in turn, contain the specific users stored within Cisco Prime AR. Cisco Prime AR references each specific UserList by **name** from a Service whose type is set to **local**. When Cisco Prime AR receives a request, it directs it to a Service. When the Service has its type property set to **local**, the Service looks up the user's entry in the specific UserList and authenticates and/or authorizes the user against that entry.



Note

Username might not include the forward slash (/) character. If the Cisco Prime AR server receives an access request packet with a User-Name attribute containing a forward slash character and the Cisco Prime AR server uses an internal UserList to look up users, the server produces an error (AX_EINVAL) and might fail. If usernames require a forward slash, use a script to translate the slash to an acceptable, unused character.

You can have more than one UserList in the **UserLists** object. Therefore, use the **UserLists** object to divide your user community by organization. For example, you might have separate **UserLists** objects for Company A and B, or you might have separate **UserLists** objects for different departments within a company.

Using separate **UserLists** objects allows you to have the same name in different lists. For example, if your company has three people named `Bob` and they work in different departments, you could create a UserList for each department, and each Bob could use his own name. Using UserLists lets you avoid the problem of `Bob1`, `Bob2`, and so on.

If you have more than one UserList, you can have a script Cisco Prime AR can run in response to requests. The script chooses the Service, and the Service specifies the actual UserList which contains the user. The alternative is dynamic properties.

The subobjects are the Users listed by name. [Table 4-2](#) lists the **UserLists** object properties.

Table 4-2 *UserLists Properties*

Property	Description
Name	Required; must be unique in UserLists.
Description	Optional description of the UserList.

Users

The **Users** object contains all of the information necessary to authenticate a user or authorize a user. Users in local UserLists can have multiple profiles. [Table 4-3](#) lists the **Users** object properties.

Table 4-3 *Users Properties*

Property	Description
Name	Required; must be unique in the specific UserList.
Description	Optional description of the user.
Password	Required; length must be between 0-253 characters.
Enabled	Required; default is TRUE, which means the user is allowed access. Set to FALSE to cause Cisco Prime AR to deny the user access.
Group (Overridden by User-Group)	Optional; when you set this to the name of a UserGroup, Cisco Prime AR uses the properties specified in that UserGroup to authenticate and/or authorize the user.
BaseProfile (Overridden by User-Profile)	Optional; when you set this to the name of a Profile and the service-Type is not equal to Authenticate Only, Cisco Prime AR adds the properties in the Profile to the Response dictionary as part of the authorization.
AuthenticationScript	Optional; when you set this property to the name of a script, you can use the script to perform additional authentication checks to determine whether to accept or reject the user.
AuthorizationScript	Optional; when you set this property to the name of a script, you can use the script to add, delete, or modify the attributes of the Response dictionary.
UserDefined1	Optional; you can use this property to store notational information which you can then use to filter the UserList. This property also sets the environment variable for UserDefined1.

HiddenAttributes Property

The HiddenAttributes property in the user object provides a concatenation of all user-level reply attributes. The Cisco Prime AR server uses the HiddenAttributes property to construct and populate a virtual attributes directory.

The HiddenAttributes property is, in fact, hidden. It is not displayed and cannot be set or modified using **aregcmd**, but when an administrator issues a **save**, all values from the user's Attributes directory go into the HiddenAttributes property and the persistent storage.

The attributes are added in a replace-if-present-add-if-not manner as used in the UserGroup-Base-Profile and User-Base-Profile.

The order of application of the attributes is as follows:

- UserGroup Base Profile
- UserGroup Attributes
- User Base Profile
- User Attributes

UserGroups

The **UserGroups** objects allow you to maintain common authentication and authorization attributes in one location, and then have many users reference them. By having a central location for attributes, you can make modifications in one place instead of having to make individual changes throughout your user community.

For example, you can use several **UserGroups** to separate users by the services they use, such as a group specifying PPP and another for Telnet.

[Table 4-4](#) lists the **UserGroups** properties.

Table 4-4 *UserGroups Properties*

Property	Description
Name	Required; must be unique in the UserGroup list.
Description	Optional description of the group.
BaseProfile	Optional; when you set this to the name of a Profile, Cisco Prime AR adds the properties in the Profile to the response dictionary as part of the authorization.
AuthenticationScript	Optional; when you set this property to the name of a Script, you can use the Script to perform additional authentication checks to determine whether to accept or reject the user.
AuthorizationScript	Optional; when you set this property to the name of a Script, you can use the Script to add, delete, or modify the attributes of the Response dictionary.

Policies

A Policy is a set of rules applied to an Access-Request. If you are using **Policies**, the first one that must be created is SelectPolicy.

[Table 4-5](#) lists the properties required for a given **Policy**.

Table 4-5 *Policies Properties*

Property	Description
Name	Required; must be unique in the Policies list
Description	Optional description of the Policy
Grouping	Optional grouping of rules

Clients

All NASs and proxy clients that communicate directly with Cisco Prime AR must have an entry in the **Clients** list. This is required because NAS and proxy clients share a secret with the RADIUS server which is used to encrypt passwords and to sign responses. [Table 4-6](#) lists the **Client** object properties.

Table 4-6 RADIUS Client Properties

Property	Description
Name	Required and should match the Client identifier specified in the standard RADIUS attribute, NAS-Identifier . The name must be unique within the Clients list.
Description	Optional description of the client.
Protocol	Required; specifies the client protocol which can be Radius, Diameter, or Tacacs-and-Radius.
IPAddress	<p>Required; must be a valid IP address and unique in the Clients list. Cisco Prime AR uses this property to identify the Client that sent the request, either using the source IP address to identify the immediate sender or using the NAS-IP-Address or NAS-IPv6-Address attribute in the Request dictionary to identify the NAS sending the request through a proxy.</p> <p>When a range is configured for a Client's IPAddress property, any incoming requests whose source address belongs to the range specified, will be allowed for further processing by the server. Similarly when a wildcard (an asterisk '*' in this case) is specified, any incoming requests whose source address matches the wildcard specification will be allowed. In both the cases, the configured client properties like SharedSecret, and Vendor are used to process the requests.</p> <p>You can specify a range of IP addresses using a hyphen as in:</p> <pre>100.1.2.11-20</pre> <p>You can use an asterisk wildcard to match all numbers in an IP address octet as in:</p> <pre>100.1.2.*</pre> <p>You can specify an IPAddress and a subnet mask together using Classless Inter-Domain Routing (CIDR) notation as in:</p> <pre>100.1.2.0/24</pre> <p>You can use the IPAddress property to set a base address and use the NetMask property to specify the number of clients in the subnet range.</p> <p>The IP address format is enhanced to support IPv6 apart from IPv4.</p> <p>You can use an asterisk wildcard to match all numbers in an IP address octet as in:</p> <pre>1124:1124:1124:1124:*:*:*</pre> <p>Note The IPv6 address must be in standard notation.</p>

Table 4-6 RADIUS Client Properties (continued)

Property	Description
SharedSecret	Required; must match the secret configured in the Client.
Type	Required; accept the default (NAS), or set it to ATM, Proxy, or NAS+Proxy.
Vendor	Optional; you can use this property when you need special processing for a specific vendor's NAS. To use this property, you must configure a Vendor object and include a Script. Cisco Prime AR provides five Scripts you can use: one for Ascend, Cisco, Cabletron, Altiga, and one for USR. You can also provide your own Script.
IncomingScript	Optional; you can use this property to specify a Script you can use to determine the services to use for authentication, authorization, and/or accounting.
OutgoingScript	Optional; you can use this property to specify a Script you can use to make any Client-specific modifications when responding to a particular Client.
EnableDynamicAuthorization	Optional; when set to TRUE, this property enables Change of Authorization and Packet of Disconnect features.
DynamicAuthorizationServer	This subdirectory is only present in a client with EnableDynamicAuthorization set to TRUE and contains properties required for CoA and PoD requests.
Port	Located under the DynamicAuthorizationServer subdirectory, the default port is 3799.
InitialTimeout	Located under the DynamicAuthorizationServer subdirectory, the default is 5000.
MaxTries	Located under the DynamicAuthorizationServer subdirectory, the default is 3.
DynamicAuthSharedSecret	Located under the DynamicAuthorizationServer subdirectory, this is the shared secret used for communicating CoA and PoD packets with the client.
PODAttributeGroup	This property is found under the DynamicAuthorizationServer subdirectory and points to a group of attributes to be included in a POD request sent to this client. These attribute groups are created and configured under the AttributeGroups subdirectory in /Radius/Advanced .
COAAttributeGroup	This property is found under the DynamicAuthorizationServer subdirectory and points to a group of attributes to be included in a CoA request sent to this client. These attribute groups are created and configured under the AttributeGroups subdirectory in /Radius/Advanced .

Table 4-6 RADIUS Client Properties (continued)

Property	Description
NetMask	<p>Specifies the subnet mask used with the network address setting configured for the IPAddress property when configuring a range of IP addresses.</p> <p>This property is not used for a single client with an IP address only. The NetMask property is used to configure multiple clients when you configure a base IP address in the IPAddress property. You can set the NetMask property for a range of 256 clients using the following example:</p> <pre>set NetMask 255.255.255.0</pre> <p>When the NetMask property indicates a pool of 256 address (255.255.255.0), the range of addresses reserved for clients is 0-255, as in 100.1.1.0-100.1.1.255.</p> <p>Note If you set the NetMask property, validation will fail if you attempt to specify a subnet mask using CIDR notation with the IPAddress property (described above).</p>
EnableNotifications	<p>Required; the default value is FALSE and indicates the client is not capable of receiving Accounting-Stop notifications from the Cisco Prime AR server.</p> <p>When set to TRUE, the client can receive Accounting-Stop notifications from the Cisco Prime AR server and additional properties must be configured under a new sub-directory named NotificationProperties.</p>
NotificationProperties	<p>When the EnableNotifications property is set to TRUE, this subdirectory contains additional properties required to support the Query-Notify feature.</p>
Port	<p>Located under the NotificationProperties subdirectory, specifies the port used by the Cisco Prime AR server to receive Accounting-Stop packets. Required when EnableNotifications is set to TRUE; the default value is 1813.</p>
InitialTimeout	<p>Located under the NotificationProperties subdirectory, specifies the timeout value in milliseconds the Cisco Prime AR server waits for an Accounting-Response packet before attempting a retry (sending another Accounting-Stop packet to the client).</p> <p>Required when EnableNotifications is set to TRUE; the default value is 5000.</p>
MaxTries	<p>Located under the NotificationProperties subdirectory, specifies the number of times the Cisco Prime AR server sends an Accounting-Stop packet to a client.</p> <p>Required when EnableNotifications is set to TRUE; the default value is 3.</p>

Table 4-6 RADIUS Client Properties (continued)

Property	Description
NotificationAttributeGroup	<p>Located under the NotificationProperties subdirectory, specifies the name of an attribute group under /Radius/Advanced/AttributeGroups that contains the attributes to be included when sending an the Accounting-Stop packet to this client.</p> <p>Required when EnableNotifications is set to TRUE; there is no default value. You must provide the name of a valid AttributeGroup and the named AttributeGroup must contain at least one valid attribute, or validation will fail.</p>
EnforceTrafficThrottling	<p>Required; the default value is TRUE and indicates enforce traffic throttling for this client. This property is under /Radius/Advanced/MaximumOutstanding/IncomingRequests.</p> <p>When set to FALSE, the traffic throttling for the packet coming from this client is bypassed.</p>

[Table 4-7](#) describes the Diameter client properties.

Table 4-7 Diameter Client Properties

Property	Description
Name	Required; must be unique in the client list.
Description	Optional; description of the client.
Protocol	Required; specifies the client protocol which can be Radius or Diameter.
HostName	Required; hostname or IP address of the Diameter client.
Vendor	Optional; you can use this property when you need special processing for a specific vendor's peer.
IncomingScript	Optional; specifies a script that you can use to make client-specific modifications when a request is received from a client.
OutgoingScript	Optional; specifies a script that you can use to make any client-specific modifications when responding to a particular client.
Port	Required; port on which the client connects with Cisco Prime AR server.
SCTP-Enabled	Required, default value is False. If set to TRUE, SCTP will be used to establish the connection with the peer else TCP will be used.

Vendors

The **Vendor** object provides a central location for specifying all of the request and response processing a particular NAS or Proxy vendor requires. Depending on the vendor, it might be necessary to map attributes in the request from one set to another, or to filter out certain attributes before sending the response to the client. For more information about standard RADIUS attributes, see [Appendix C, "RADIUS Attributes."](#)

**Note**

When you have also set **/Radius/IncomingScript**, Cisco Prime AR runs that script before the vendor's script. Conversely, when you have set a **/Radius/Outgoing** script, Cisco Prime AR runs the vendor's script before that script.

Table 4-8 lists the **Vendor** object properties.

Table 4-8 Vendor Properties

Property	Description
Name	Required; must be unique in the Vendors list.
Description	Optional description of the vendor.
IncomingScript	Optional; when you specify an IncomingScript, Cisco Prime AR runs the script on all requests from clients that specify that vendor.
OutgoingScript	Optional; when you specify an OutgoingScript, Cisco Prime AR runs the script on all responses to the Client.

Scripts

The **Script** objects define the function Cisco Prime AR invokes whenever the **Script** is referenced by name from other objects in the configuration.

You can write three types of scripts:

- REX (RADIUS EXtension) scripts are written in C or C++, and thus are compiled functions that reside in shared libraries
- Tcl scripts are written in Tcl, and are interpreted functions defined in source files.
- Java scripts

**Note**

For more information about how to write scripts and how to incorporate them into Cisco Prime AR, see [Chapter 11, "Using Extension Points."](#)

**Note**

Cisco is not liable for scripts developed by clients. See [Client Scripting](#) in [Chapter 1, "Overview."](#)

Table 4-9 lists the **Script** object properties.

Table 4-9 Script Object Properties

Property	Description
Name	Required; must be unique in the Scripts list.
Description	Optional description of the script.
Language	Required; specify either REX, Tcl, or Java.

Table 4-9 Script Object Properties (continued)

Property	Description
Filename	Required; specifies either a relative or absolute path. When you specify a relative path, the path must be relative to the \$INSTALL/scripts/radius/\$Language directory. When you specify an absolute path, the server must be able to reach it.
EntryPoint	Optional; when not set, Cisco Prime AR uses the value specified in the Name property.
InitEntryPoint	Optional; if set, it must be the name of the global symbol Cisco Prime AR should call when it initializes the shared library at system start up, and just before it unloads the shared library.
InitEntryPointArg	Optional; when set, it provides the arguments to be passed to the InitEntryPoint in the environmental variable Arguments .
ClassName	For Java language scripts, the name of the class that implements the extension interface; the .class file should be placed in /cisco-ar/scripts/radius/java
InitializeArg	Optional for Java language scripts; set to a string to be passed to the Initialize method if the class implements the optional ExtensionWithInitialization interface.

The **InitEntryPoint** properties allow you to perform initialization before processing and then cleanup before stopping the server. For example, when Cisco Prime AR unloads the script (when it stops the RADIUS server) it calls the **InitEntryPoint** again to allow it to perform any clean-up operations as a result of its initialization. One use of the function might be to allow the script to close an open Accounting log file before stopping the RADIUS server.

**Note**

When you use a Cisco Prime AR file service, Cisco Prime AR automatically closes any opened files. However, if you write scripts that manipulate files, you are responsible for closing them.

**Note**

If you have more than one extension point script (defined under **/Radius/Scripts**) using the same Java class, only one instance of the class is created and used for all the extension point scripts.

Services

Cisco Prime AR supports authentication, authorization, and accounting (AAA) services. In addition to the variety of built-in AAA services (specified in the **Type** property), Cisco Prime AR also enables you to add new AAA services through custom shared libraries.

[Table 4-10](#) lists the common **Services** properties. There are additional properties depending on the type of service.

Table 4-10 Common Service Properties

Property	Description
Name	Required; must be unique in the Services list.
Description	Optional description of the service.
Type	Required, must set it to a valid Cisco Prime AR service.
OutagePolicy	Required; the default is RejectAll . This property defines how Cisco Prime AR handles requests if all servers listed in the RemoteServers properties are unavailable (that is, all remote RADIUS servers are not available). You must set it to one of the following: AcceptAll , DropPacket , or RejectAll .
OutageScript	Optional; if you set this property to the name of a script, Cisco Prime AR runs it when an outage occurs. This property allows you to create a script that notifies you when the RADIUS server detects a failure.

**Note**

OutagePolicy also applies to Accounting-Requests. If an Accounting-Request is directed to an unavailable Service, then the values in [Table 4-11](#) apply.

Table 4-11 OutagePolicy Request Packets

Property	Description	Accounting-Request Description
AcceptAll	Continues processing the packet as if the Service was successful.	The Accounting-Request will continue through the server and a response will be sent.
DropPacket	Immediately drops the packet, no further processing, and does not send any response to the client for this packet.	The packet will be discarded and it will not be processed any further.
RejectAll	Rejects the packet, but continues processing it and sends the client a reject response.	The request will be dropped and no more processing will be done.

Types of Services

This section lists the types of services available in Cisco Prime AR with their required and optional properties. The service you specify determines what additional information you must provide.

This section contains the following topics:

- [Domain Authentication](#)
- [EAP Services](#)
- [File](#)
- [Group](#)
- [Java](#)
- [LDAP](#)

- Local
- ODBC
- ODBC-Accounting
- Prepaid Services
- RADIUS
- Radius Query
- RADIUS-Session
- Rex
- WiMAX
- Diameter
- M3UA

Domain Authentication

The Domain Authentication service type, domain-auth, is used with a Remote Server of the same type to provide support for authentication against Windows Domain Controller/Active Directory (WDC/AD). The following example lists the default configuration for a domain-auth service which are all common service properties described in [Table 4-10](#):

```
[ //localhost/Radius/Services/wdc ]
  Name = wdc
  Description =
  Type = domain-auth
  IncomingScript~ =
  OutgoingScript~ =
  OutagePolicy~ = RejectAll
  OutageScript~ =
  MultipleServersPolicy = Failover
  RemoteServers/
```

EAP Services

Cisco Prime AR supports Extensible Authentication Protocol (EAP) and Protected EAP (PEAP) to provide a common protocol for differing authentication mechanisms. EAP enables the dynamic selection of the authentication mechanism at authentication time based on information transmitted in the Access-Request. Cisco Prime AR provides the following EAP services:

- EAP-FAST
- EAP-GTC
- EAP-LEAP
- EAP-MD5
- EAP-MSChapV2
- EAP-Negotiate
- EAP-SIM
- EAP-Transport Level Security (TLS)
- EAP-Tunneled TLS (TTLS)

- PEAP Version 0 (Microsoft PEAP)
- PEAP Version 1 (Cisco PEAP)

See [Chapter 9, “Extensible Authentication Protocols,”](#) for detailed information about properties used in EAP-type services.

File

Specify the **file** service when you want Cisco Prime AR’s RADIUS Server to perform local accounting using a specific file. Every **file** Service in your configuration will cause a file with the configured name to be created when the server is started, even if the service is not being invoked by any request packets. [Table 4-12](#) lists the properties used for a **file** service.

Table 4-12 File Service Properties

Property	Description
Type	Required; must be set to group for a group service.
IncomingScript	Name of script to run when the service starts.
OutgoingScript	Name of script to run when the service ends.
OutagePolicy	Required; the default is RejectAll . This property defines how Cisco Prime AR handles requests if all servers listed in the RemoteServers properties are unavailable (that is, all remote RADIUS servers are not available). You must set it to one of the following: AcceptAll , DropPacket , or RejectAll .
OutageScript	Optional; if you set this property to the name of a script, Cisco Prime AR runs it when an outage occurs. This property allows you to create a script that notifies you when the RADIUS server detects a failure.
FilenamePrefix	Required; a string that specifies where Cisco Prime AR writes the account records. It must be either a relative or absolute path. When you specify a relative path, it must be relative to the \$INSTALL/logs directory. When you specify an absolute path, the server must be able to reach it. The default is Accounting .
MaxFileSize	Optional; stored as a string, but is composed of two parts, a number and a units indicator (<n> <units>) in which the unit is one of: K, Kilobyte, Kilobytes, M, Megabyte, Megabytes, G, Gigabyte, Gigabytes. The default is ten megabytes.
MaxFileAge	Optional; stored as a string, but is composed of two parts, a number and a units indicator (<n> <units>) in which the unit is one of: H, Hour, Hours, D, Day, Days, W, Week, Weeks. The default is one day.
RolloverSchedule	Indicates the exact time including the day of the month or day of the week, hour and minute to roll over the accounting log file.
UseLocalTimeZone	When set to TRUE, indicates the accounting records' TimeStamp is in local time. When set to FALSE, the default, accounting records' TimeStamp is in GMT.

Cisco Prime AR opens the file when it starts the RADIUS server and closes the file when you stop the server. You can depend on Cisco Prime AR flushes the accounting record to disk before it acknowledges the request.

Based on the maximum file size and age you have specified, Cisco Prime AR closes the accounting file, moves it to a new name, and reopens the file as a new file. The name Cisco Prime AR gives this accounting file depends on its creation and modification dates.

- If the file was created and modified on the same date, the filename is **FileNamePrefix-`<yyyymmdd>-<n>.log`**. The date is displayed as year, month, day, number.
- If the file was created on one day and modified on another, the filename is **FileNamePrefix-`<yyyymmdd>-<yyyymmdd>-<n>.log`**. The dates are creation, modification, and number.

Group

A group service contains a list of references to other services and specifies whether the responses from each of the services should be handled as a logical AND or a logical OR function. You specify AND or OR in the Result-Rule attribute of Group Services. The default value is AND.

Table 4-13 lists the properties used to configure a **group** service.

Table 4-13 Group Service Properties

Property	Description
Type	Required; must set it to group.
IncomingScript	Optional; name of script to run when the service starts.
OutgoingScript	Optional; name of script to run when the service ends.
ResultRule	<p>When set to AND (the default), the response from the GroupService is positive if each of the services referenced return a positive result. The response is negative if any of the services reference return a negative result.</p> <p>When set to OR, the response from the GroupService is positive if any of the services referenced return a positive result. The response is negative if all the referenced services return a negative result.</p> <p>The settings parallel-AND or parallel-OR are similar to AND and OR settings, except that each referenced service processes requests simultaneously instead of asking each reference service sequentially to save processing time.</p>
GroupServices	Use the GroupServices subdirectory to specify the subservices in an indexed list to provide specific ordering control of which services to apply first. Each subservice listed must be defined in the Services section of the Radius configuration and cannot be a of type group, eap-leap, or eap-md5.

If Result-Rule is set to AND, the response from the Group Service is positive if each of the services referenced return a positive result. The response is negative if any of the services reference return a negative result. If Result-Rule is set to OR, the response from the Group Service is positive if any of the services referenced return a positive result. The response is negative if all the referenced services return a negative result.

When the Result-Rule attribute is set to AND or OR, each referenced service is accessed sequentially, and the Group Service waits for a response from the first referenced service before moving on to the next service (if necessary). If a service takes a long time to respond, that causes a delay in sending the request to the next referenced server.

The ResultRule settings parallel-and and parallel-or are similar to the AND and OR settings except that they ask each referenced service to process the request simultaneously instead of asking each referenced server sequentially, thereby saving processing time.

A parallel-and setting might respond with its own reply as soon as it receives a negative response, but otherwise must wait for all responses before it can respond with a positive reply. Likewise, a parallel-or might respond as soon as it receives a positive response, but otherwise must wait for all responses before it can reply with a negative response.

If a service referenced from a Group Service is of type RADIUS and if Accounting-Requests are being processed by the Group Service, setting the AckAccounting property in the remote server will affect the behavior of the parallel-or Group Service. This is because if AckAccounting is set to FALSE, the RADIUS Remote Server will not wait for the response from the remote server but returns a response immediately. Since the Group Service is set to parallel-or, after it receives the response from the RADIUS service, it is free to send a response itself. This will have the effect that a response is sent very quickly from the Group Service acknowledging the Accounting-Request and responses from the other referenced services are handled as they arrive.

Note that since AckAccounting was set to FALSE, there is no guarantee that the Remote Server successfully processed the request. Since it is a RADIUS Remote Server, the Cisco Prime AR server attempts for MaxTries to send the request to the server and to get back an acknowledgement, but if that fails, there will be no indication to the client about that event. The acknowledgement to the client has been sent long before.

Java

Specify the **java** service type when you want to create a custom service and use a script for authentication, authorization, or accounting. [Table 4-14](#) lists the properties required to configure a java service.

A java service uses an extension point script to provide the service's functionality and handles both RADIUS and TACACS requests for authentication, authorization, and accounting.

Table 4-14 Java Service Properties

Property	Description
Type	Required; must set it to java.
IncomingScript	Name of script to run when the service starts.
OutgoingScript	Name of script to run when the service ends.
OutagePolicy	Required; the default is RejectAll . This property defines how Cisco Prime AR handles requests if all servers listed in the RemoteServers properties are unavailable (that is, all remote RADIUS servers are not available). You must set it to one of the following: AcceptAll , DropPacket , or RejectAll .
OutageScript	Optional; if you set this property to the name of a script, Cisco Prime AR runs it when an outage occurs. This property allows you to create a script that notifies you when the RADIUS server detects a failure.
ClassName	Set to the name of a class that implements the Extension interface.
InitializeArg	Optional; set to a string to be passed to the Initialize method if the class implements the optional ExtensionWithInitialization interface.

LDAP

Specify the **ldap** service type when you want to use a particular LDAP remote server for authentication and/or authorization. [Table 4-15](#) lists the properties used to configure an LDAP service.

When using LDAP for authentication and a local database for authorization, ensure that the usernames in both locations are identical with regard to case sensitivity.

Table 4-15 LDAP Service Properties

Property	Description
Type	Required, must set it to ldap
IncomingScript	Name of script to run when the service starts.
OutgoingScript	Name of script to run when the service ends.
OutagePolicy	Required; the default is RejectAll . This property defines how Cisco Prime AR handles requests if all servers listed in the RemoteServers properties are unavailable (that is, all remote RADIUS servers are not available). You must set it to one of the following: AcceptAll , DropPacket , or RejectAll .
OutageScript	Optional; if you set this property to the name of a script, Cisco Prime AR runs it when an outage occurs. This property allows you to create a script that notifies you when the RADIUS server detects a failure.
MultipleServersPolicy	Required; must be set to either Failover or RoundRobin . When you set it to Failover , Cisco Prime AR directs requests to the first server in the list until it determines the server is offline. At which time, Cisco Prime AR redirects all requests to the next server in the list until it finds a server that is online. When you set it to RoundRobin , Cisco Prime AR directs each request to the next server in the RemoteServers list to share the resource load across all of the servers listed in the RemoteServers list.
RemoteServers	Required; an indexed list from 1 to <n>. Each entry in the list is the name of a RemoteServer.

Local

Specify **local** when you want the Cisco Prime AR server to perform the authentication and authorization using a specific UserList. For more information, see the “[UserLists](#)” section on page 4-3. [Table 4-16](#) lists the properties used to configure a **local** service.

Table 4-16 Local Service Properties

Property	Description
Type	Required, must set it to local .
IncomingScript	Optional; name of script to run when the service starts.
OutgoingScript	Optional; name of script to run when the service ends.

Table 4-16 Local Service Properties (continued)

Property	Description
OutagePolicy	Required; the default is RejectAll . This property defines how Cisco Prime AR handles requests if all servers listed in the RemoteServers properties are unavailable (that is, all remote RADIUS servers are not available). You must set it to one of the following: AcceptAll , DropPacket , or RejectAll .
OutageScript	Optional; if you set this property to the name of a script, Cisco Prime AR runs it when an outage occurs. This property allows you to create a script that notifies you when the RADIUS server detects a failure.
UserLists	Required; this object contains all of the individual UserLists, which in turn, contain the specific users stored within Cisco Prime AR. Cisco Prime AR references each specific UserList by name from a Service whose type is set to local . When Cisco Prime AR receives a request, it directs it to a Service. When the Service has its type property set to local , the Service looks up the user's entry in the specific UserList and authenticates and/or authorizes the user against that entry.

ODBC

Specify **odbc** when you want to use an ODBC service for authentication, authorization and accounting through an ODBC data store. Use an ODBC service to authenticate and authorize an access requests by querying user information through ODBC and to insert accounting records into a data store through ODBC. [Table 4-17](#) lists the properties used to configure an ODBC service.

Table 4-17 ODBC Service Properties

Property	Description
Type	Required; must set it to odbc .
IncomingScript	Optional; name of script to run when the service starts.
OutgoingScript	Optional; name of script to run when the service ends.
OutagePolicy	Required; the default is RejectAll . This property defines how Cisco Prime AR handles requests if all servers listed in the RemoteServers properties are unavailable (that is, all remote RADIUS servers are not available). You must set it to one of the following: AcceptAll , DropPacket , or RejectAll .
OutageScript	Optional; if you set this property to the name of a script, Cisco Prime AR runs it when an outage occurs. This property allows you to create a script that notifies you when the RADIUS server detects a failure.

Table 4-17 ODBC Service Properties (continued)

Property	Description
MultipleServersPolicy	<p>Required; must be set to either Failover or RoundRobin.</p> <p>When you set it to Failover, Cisco Prime AR directs requests to the first server in the list until it determines the server is offline. At which time, Cisco Prime AR redirects all requests to the next server in the list until it finds a server that is online.</p> <p>When you set it to RoundRobin, Cisco Prime AR directs each request to the next server in the RemoteServers list to share the resource load across all of the servers listed in the RemoteServers list.</p>
RemoteServers	Required; an indexed list from 1 to <n>. Each entry in the list is the name of a RemoteServer.

ODBC-Accounting

If you use the Oracle Accounting feature, you must configure an ODBC-Accounting RemoteServer object. See [Configuring an ODBC/OCI RemoteServer, page 21-7](#), for more information on ODBC-Accounting RemoteServer.

Prepaid Services

Cisco Prime Access Registrar (Cisco Prime AR) supports two types of prepaid billing, IS835C and Cisco Real-time Billing (CRB), a Cisco proprietary solution. See [IS835C Prepaid Billing, page 16-2](#) for more information on Prepaid -IS835C. See [CRB Prepaid Billing, page 16-7](#) for more information on Prepaid-CRB.

RADIUS

Specify the **radius** service type when you want to use a particular RADIUS remote server for authentication and authorization. [Table 4-18](#) lists the properties used to configure a RADIUS service.

Table 4-18 RADIUS Service Properties

Property	Description
Type	Required; must set it to radius .
IncomingScript	Optional; name of script to run when the service starts.
OutgoingScript	Optional; name of script to run when the service ends.
OutagePolicy	Required; the default is RejectAll . This property defines how Cisco Prime AR handles requests if all servers listed in the RemoteServers properties are unavailable (that is, all remote RADIUS servers are not available). You must set it to one of the following: AcceptAll , DropPacket , or RejectAll .
OutageScript	Optional; if you set this property to the name of a script, Cisco Prime AR runs it when an outage occurs. This property allows you to create a script that notifies you when the RADIUS server detects a failure.

Table 4-18 RADIUS Service Properties (continued)

Property	Description
MultipleServersPolicy	<p>Required; must be set to either Failover or RoundRobin.</p> <p>When you set it to Failover, Cisco Prime AR directs requests to the first server in the list until it determines the server is offline. At which time, Cisco Prime AR redirects all requests to the next server in the list until it finds a server that is online.</p> <p>When you set it to RoundRobin, Cisco Prime AR directs each request to the next server in the RemoteServers list to share the resource load across all of the servers listed in the RemoteServers list.</p>
RemoteServers	Required; an indexed list from 1 to <n>. Each entry in the list is the name of a RemoteServer.

Radius Query

Cisco Prime AR supports a new service type called radius-query that can be used to query cached data through Radius packets. This radius-query service contains a list of session managers to be queried from and a list of (cached) attributes to be returned in the Access-Accept packet in response to a Radius Query request. Cisco Prime AR also supports caching and querying of multivalued attributes.

The Radius Query service should be selected through an extension point script or through the Rule and Policy Engine by setting it to a new environment variable named Query-Service. The reason for this is that the Radius Query request comes in as an Access-Request and the server has no way of knowing whether it is a Radius Query request or normal authentication request. Setting the Query-Service environment variable tells the Cisco Prime AR server that the request is a Radius Query request so the Cisco Prime AR server can process the request with the radius-query service set in the Query-Service environment variable.

When a Radius Query service is selected to process an Access-Request, it queries the configured list of Session Managers for a matching record using the QueryKey value configured in the session-cache Resource Manager referenced under these Session Managers as key. If a matching record is found, an Access-Accept containing a list of cached attributes present (based on the configuration) in the matched record is sent back to the client. If the session cache contains a multivalued attribute, all values of that attribute are returned in the response as a multivalued attribute. If there is no matching record, an Access-Reject packet is sent to the client.

Cisco Prime AR introduces scripting points at the Session Manager level along with automated programmable interfaces (APIs) to access cached information present in the session record. You can use these scripting points and APIs to write extension point scripts to modify the cached information.

The following example shows the default configuration of a radius-query service:

```
[ //localhost/Radius/Services/radius-query ]
  Name = radius-query
  Description =
  Type = radius-query
  IncomingScript~ =
  OutgoingScript~ =
  SessionManagersToBeQueried/
  AttributesToBeReturned/
```

Table 4-19 lists the properties used to configure a Radius Query service.

Table 4-19 Radius Query Service Properties

Property	Description
Type	Required; must set it to radius query .
IncomingScript	Optional; name of script to run before this service starts processing on the request.
OutgoingScript	Optional; name of script to run after this service completes processing on the request.
SessionManagersToBeQueried	Lists Session Managers to be queried for the target record. If this list is empty, all Session Managers having session-cache Resource Managers will be queried for the target record. Otherwise, only those SessionManagers configured under SessionManagerToBeQueried are queried. If the targeted record is found in a Session Manager, the query stops and the response is returned to the client.
AttributesToBeReturned	Lists attributes to be returned if present in a matched record. If this list is empty, all attributes cached in a matched session are returned. If a configured attribute is not present in the matched record, that attribute is ignored. Note The User-Password attribute will not be returned in query responses and cannot be configured under AttributesToBeReturned.

When an Access-Request packet is received by the Cisco Prime AR server, the session-cache Resource Manager caches the configured attributes in the session with the configured QueryKey as the key to the cached data. In the TAL solution, the QueryKey will usually be Framed-IP-Address. If an Accounting-Requestor Accounting-Start packet is received for the same session, the cached data is updated if necessary. If there is a multivalued attribute in the Access-Request packet or Accounting-Request packet, the Cisco Prime AR server caches all the values of that attributes.

In TAL, when the SSG receives an IP packet originating from a user unknown to the SSG, it sends an Access-Request packet to the Cisco Prime AR server in which the User-Name and Framed-IP-Address attributes both contain the user's source IP address, and the Service-Type is set to Outbound, among other attributes. These attributes and their values distinguish Radius Query requests from normal authentication requests in TAL.



Note

In solutions other than TAL, the criterion that distinguishes Radius Query requests from normal authentication requests might be different.

A new environment variable, Query-Service, can be set to the name of a radius-query service, in an extension point script, or through the Rule and Policy engine so the Cisco Prime AR server knows the current request is a Radius Query request and processes it with the radius-query service value set in the Query-Service environment variable.

API Calls

Cisco Prime AR provides several new API calls you can use to get, put, and delete the cached attributes present in the session record.

The entry point function changes slightly to take a fifth argument which is a pointer to a structure containing the new API calls:

```
typedef int (REXAPI * RexEntryPointFunction)
(
    int iScriptingPoint,
    rex_AttributeDictionary_t* pRequest,
    rex_AttributeDictionary_t* pResponse,
    rex_EnvironmentDictionary_t* pRadius,
    rex_SessionRecord_t* pSession
);
```

However, you can continue to write extension point scripts with four arguments as well, for example without the pSession argument.

The following are API calls and their functionality. All these API calls fail gracefully when they are invoked from any scripting point other than the Session Manager scripting points.

const char* get

```
const char* get(
    rex_SessionRecord_t* pSession,
    const char* pszAttribute,
    int <iIndex>,
    abool_t* <pbMore>
)
```

This API returns the value of the <iIndex>'d instance of the attribute cached in the session, represented as a string. When the session does not contain the attribute, an empty string is returned. When <pbMore> is non-zero, this method sets <pbMore> to TRUE when more instances of the same attribute exist after the one returned and to FALSE otherwise. This can be used to determine whether another call to get() method should be made to retrieve other instances of the same attribute.

abool_t put

```
abool_t put(
    rex_SessionRecord_t* pSession,
    const char* pszAttribute,
    const char* <pszValue>,
    int <iIndex>
)
```

When <iIndex> equals the special value REX_REPLACE, this method replaces any existing instances of <pszAttribute> with a single value in the session. When <iIndex> equals the special value REX_APPEND, it appends a new instance of <pszAttribute> to the end of the list of existing instances of <pszAttribute>. When <iIndex> equals the special value REX_AUGMENT, this method only puts <pszAttribute> when it does not already exist. Otherwise, a new instance of <pszAttribute> is inserted/replaced at the position indicated. This method returns TRUE if it is able to cache the attribute successfully and FALSE otherwise.

abool_t remove

```
abool_t remove(
    rex_SessionRecord_t* pSession,
    const char* pszAttribute,
    int <iIndex>
)
```

This method removes the <pszAttribute> from the session. When <iIndex> equals the special value REX_REMOVE_ALL, this method removes any existing instances of <pszAttribute>. Otherwise, it removes the instance of <pszAttribute> at the position indicated. It returns FALSE when <pszAttribute> is not present at any index in the session record and returns TRUE otherwise.

rex_SessionInfo_t*

```
rex_SessionInfo_t* getSessionInfo(rex_SessionRecord_t* pSession )
```

This method returns the pointer to a structure that contains the other session-related information, like Session Id, Session Start time, Session Last Accessed Time, present in the session record. The structure that holds this information will appear as follows:

```
typedef struct rex_SessionInfo_s
{
    auint32_t iSessionId;
    auint32_t tSessionStartTime;
    auint32_t tSessionLastAccessedTime;
} rex_SessionInfo_t;
```

Tcl API calls

To use the extension point scripts written in Tcl, define the procedure at the session manager level as shown below:

```
proc test { request response environ session } {
}
```

There is a fourth argument *session* that needs to be passed to the Tcl procedure and the API calls that are intended to operate on the session record need to use this *session* dictionary.

API calls in Tcl have the same meaning with same number arguments and return values as described in Rex. The only difference is that the API `getSessionInfo` will not return a structure as in Rex but it will return the info as a string, as in the following example:

```
Session-ID=1, Session-Start-Time=1102099334, Session-Last-Accessed-Time=1102099334
```

Java API calls

There are two new interfaces `ExtensionForSession` and `ExtensionForSessionWithInitialization` and the customers wishing to use the extension point scripts written in Java at the session manager level needs to implement one of these interfaces.

The `runExtension` method of these interfaces will look as below:

```
public int runExtension
( int iExtensionPoint,
  AttributeDictionary request,
  AttributeDictionary response,
  EnvironmentDictionary environment,
  SessionRecord session
);
```

API calls that are intended to operate on session record needs to use this 'session' dictionary.

API calls in Java have the same meaning with same number arguments and return values as described in Rex. The only difference is that the API `getSessionInfo` will not return a structure as in Rex but it will return the info as a string. For example:

```
Session-ID=1, Session-Start-Time=1102099334, Session-Last-Accessed-Time=1102099334
```

Existing scripts written in any of these three languages will not be affected with the introduction of the new 'session dictionary' argument. And the customers can use a script with any number of arguments (i.e with or without the last 'session dictionary' argument) at any extension point script. If there is no session to operate on, for example when the customer is trying to use session dictionary argument at an extension point other than session manager's, the Cisco Prime AR gracefully returns an error logging the appropriate message.

The simple *replace or add if it does not exist* model can still be used for simple modifications as before without the need to write a script. If the cached attributes are updated in the IncomingScript and if customers do not want them to be touched or updated again when the processing reaches session-cache resource manager, they can set the OverwriteAttributes property of the session-cache resource manager to FALSE so that the session-cache resource manager will not operate on this packet.

RADIUS-Session

A new Service step has been added in the processing of Access-Request and Accounting packets. This is an additional step after the AA processing for Access packet or Accounting processing for Accounting packet, but before the local session management processing. The Session-Service should have a service type of radius-session.

An environment variable Session-Service is introduced to determine the Session-Service dynamically. You can use a script or the rule engine to set the Session-Service environment variable. See [Cross Server Session and Resource Management, page 1-9](#) for more information on RADIUS-Session.

Rex

Specify the **rex** service type when you want to create a custom service and use a script for authentication, authorization, or accounting. [Table 4-20](#) lists the properties required to configure a **rex** service.

Table 4-20 *rex Service Properties*

Property	Description
Type	Required; must be set to rex .
IncomingScript	Optional; name of script to run when the service starts.
OutgoingScript	Optional; name of script to run when the service ends.
OutagePolicy	Required; the default is RejectAll . This property defines how Cisco Prime AR handles requests if all servers listed in the RemoteServers properties are unavailable (that is, all remote RADIUS servers are not available). You must set it to one of the following: AcceptAll , DropPacket , or RejectAll .
OutageScript	Optional; if you set this property to the name of a script, Cisco Prime AR runs it when an outage occurs. This property allows you to create a script that notifies you when the RADIUS server detects a failure.
Filename	Required; must be either a relative or an absolute path to the shared library containing the Service. When the pathname is relative, it must be relative to \$INSTALL/Scripts/Radius/rex .
EntryPoint	Required; must be set to the function's global symbol.
InitEntryPoint	Required; must be the name of the global symbol Cisco Prime AR should call when it initializes the shared library and just before it unloads the shared library. Note A rex service must have an InitEntryPoint even if the service only returns REX_OK.
InitEntryPointArgs	Optional; when set, it provides the arguments to be passed to the InitEntryPoint in the environmental variable Arguments .

For more information about scripting, see [Chapter 11, “Using Extension Points.”](#) For more information about using the REX Attribute dictionary, see [Appendix A, “Cisco Prime Access Registrar Tcl, REX and Java Dictionaries.”](#)

WiMAX

Cisco Prime AR uses the Extensible Authentication Protocol (EAP) to enable the WiMAX feature. It also caches the IP attributes and Mobility Keys that are generated during network access authentication. To enable caching of the WiMAX attributes, you must configure the respective resource managers. See [WiMAX in Cisco Prime Access Registrar, page 10-2](#), for more information on WiMAX.

Diameter

Diameter works with the rule policy engine to perform the routing for multiple peers. The following are the multiple peer policies supported with the proxy service to route the traffic:

- RoundRobin
- FailOver
- IMSI Range Based

For more information, refer [Diameter Proxy Agent, page 8-22](#).

The following configuration is used to add Diameter proxy:

```
[ //localhost/Radius/Services/dia-proxy ]
Name = diameter-proxy
  Description =
  Type = diameter
  Realm = cisco.com
  Role = Proxy
  IncomingScript~ =
  OutgoingScript~ =
  Applications/
    Entries 1 to 1 from 1 total entries
    Current filter: <all>

NASREQ/
  Name = NASREQ
  Description =
  IsVendorSpecific = FALSE
  ApplicationID = 1
  StickySessionKey = Session-Id#1
  StickyCreationCmdList = 265||271::Accounting-Record-Type=2
  StickyDeletionCmdList = 275||271::Accounting-Record-Type=4
  DeMultiplexCCTerminateRequest = FALSE
  MultiplePeersPolicy = RoundRobin
  Peers/
    Entries 1 to 1 from 1 total entries
    Current filter: <all>

  hss1/
    Name = hss1
    HostName = gordon-ar1
    Metric = 2
    Weight = 0
    IMSIRanges =
```

The following configuration is used to add Diameter local:

```
[ //localhost/Radius/Services/dia-local ]
  Name = dia-local
  Description =
  Type = diameter
  Realm = abc.com
  Role = Local
  IncomingScript~ =
  OutgoingScript~ =
  AuthenticationService = local-users
  AccountingService = local-file
  Peers/
    Entries 1 to 1 from 1 total entries
    Current filter: <all>

    murdcoh-ar1/
      Name = murdcoh-ar1
      HostName = murdoch-ar1
      IsVendorSpecific = FALSE
      ApplicationID = 1
      Metric = 2
```

The following configuration is used to add Diameter relay:

```
[ //localhost/Radius/Services/dia-relay ]
  Name = dia-relay
  Description =
  Type = diameter
  Realm = abc.com
  Role = relay
  Peers/
    Entries 1 to 1 from 1 total entries
    Current filter: <all>

    hss1/
      Name = hss1
      HostName = 10.77.240.69
      IsVendorSpecific = FALSE
      ApplicationID = 1
      Metric = 2
```

The following configuration is used to add Diameter redirect:

```
[ //localhost/Radius/Services/dia-redirect ]
  Name = dia-relay
  Description =
  Type = diameter
  Realm = abc.com
  Role = redirect
  Peers/
    Entries 1 to 1 from 1 total entries
    Current filter: <all>

    redirectserver/
      Name = redirectserver
      HostName = 10.77.240.69
      IsVendorSpecific = FALSE
      ApplicationID = 1
      Metric = 2
```

Table 4-21 describes the Diameter Service properties.

Table 4-21 Diameter Service Properties

Property	Description
Name	Required; name of the Diameter server.
Realm	Required; realm of the route. Must be unique for a route table.
Incoming Script	Optional; enabled when role is set to Proxy or Local. When set, must be the name of a known incoming script. Cisco Prime AR runs the IncomingScript before proxying the diameter packet to the remote diameter server.
Outgoing Script	Optional; enabled when role is set to Proxy or Local. When set, must be the name of a known outgoing script. Cisco Prime AR runs the OutgoingScript after it receives the response from the remote Diameter server.
Description	Optional; description of the Diameter server.
Role	Required; specifies the role that the diameter entity will play in resolving messages matching the realm. The role can be any one of the following: Relay - Application acting as a Relay Agent. Redirect - Application acting as a Redirect Agent. Proxy - Application acting as a Proxy Agent. When the role is set to Proxy, the IncomingScript and OutgoingScript points are enabled. Local - Application processes the requests locally. When the role is set to Local, the AuthenticationService and AccountingService are enabled. By default, the Proxy option is selected. However, you can select another option from the drop-down list.
AuthenticationService	Required; used when service is configured to process the diameter requests locally. Set to valid service of type (local/ldap/odbc) to authenticate the user. This field is displayed when you select the role type as 'Local' in the Role field.
AccountingService	Required; used when service is configured to process the accounting requests locally. Set to valid accounting service of type(file/odbc-accounting) to write the accounting records. This field is displayed when you select the role type as 'Local' in the Role field.
Type	Required; specifies the service type. The service type 'Diameter' is automatically displayed in this field.

Peer Definitions tab

This tab is displayed when you select the 'Local', 'Relay', or 'Redirect' option in the Role field.

Name	Required; name of the peer.
Host Name	Required; the hostname or IP address of the peer. The hostname must exist in the client list for the route to be active.
Metric	Required; metric value for the peer entry. The higher the value the lower the preference. The highest value of preference is 0.

Table 4-21 *Diameter Service Properties (continued)*

Property	Description
VendorSpecific	Required; the default is FALSE. If set to FALSE, the application is ordinary application and user is prompted to enter the ApplicationID. If set to TRUE, the application is a VendorSpecific Application. User is prompted to enter VendorSpecificApplicationID and VendorID.
VendorID	Required; specifies the VendorID for the application. Example: DIAMETER 3GPP Cx APPLICATION VendorSpecificApplicationID 16777216 VendorID 10415
VendorSpecificApplicationID	Required; specifies the integer value for the vendor specific application.
ApplicationID	Required; application used in the route. The application Id should be available in /Advanced/Diameter/Applications.

Applications tab

This tab is displayed when you select the 'Proxy' option in the Role field.

Name	Required; name of the application.
Description	The description of the application.
ApplicationID	Required; specifies the unique integer value for the application. It represents the applicationid of the Application used for load balancing the diameter messages.
EnableSticky	Required; default is FALSE. If set to True, the sticky entries for load balancing is enabled and the user is prompted to enter the values for StickySessionKey, StickyCreationCmdList, and StickyDeletionCmdList.
DeMultiplexCCTerminateRequest	Optional; default is FALSE. If set to True, Cisco Prime AR generates and sends multiple Credit Control Update (CCR-U) requests corresponding to an incoming diameter Credit Control Termination (CCR-T) request, while proxying Gy messages between the Gateway GPRS Support Node (GGSN) and Online charging system (OCS). The CCR-U requests are generated based on the number of RGs present in CCR-T message. For more information, see Configuring Cisco Prime AR to Demultiplex the Diameter CCR-T, page 8-26 .
MultiplePeersPolicy	Required; must be set to RoundRobin, FailOver, or IMSIRangeBased. Policy used by the Cisco Prime AR server to load balance the peers.

Table 4-21 *Diameter Service Properties (continued)*

Property	Description
StickySessionKey	<p>Required; used as the sticky key for mapping the sticky sessions. Set the value to a valid AVP in order to use the sticky key for maintaining diameter sessions. This ensures that Cisco Prime AR maps the request to the same server for all the subsequent messages using the sticky key. For example, set StickyAVP "Session-Id".</p> <p>When the Cisco Prime AR server receives the CCR-I request, Cisco Prime AR extracts the Session-Id from the request packet, maps the Session to the peer configured in the list, and forwards the request to the chosen peer. Cisco Prime AR chooses the same peer for all the subsequent messages(CCR-Update/CCR-Terminate) with same Session-Id.</p>
StickyCreationCmdList	<p>Required; specifies the command list to create the sticky entries.Specify the list of ' ' separated command code, AVP name, and its value to create the sticky sessions.</p> <p>The following is the StickyCreationCmdList format:</p> <pre><commandcode1>::<AVPName1=Value1> <commandcode2<::<AVPName2=Value2> <commandcode3></pre> <p>For example, if the sticky session entries need to created based on command code '265' or based on command code '271' with Accounting-Record-Type value as 2, use the format below:</p> <pre>Set StickyCreationCmdList "265 271:: Accounting-Record-Type=2"</pre>
StickyDeletionCmdList	<p>Required; specifies the command list to delete the sticky entries.Specify the list of ' ' separated command code, AVP name, and its value to delete the sticky sessions.</p> <p>The following is the StickyDeletionCmdList format:</p> <pre><commandcode1>::<AVPName1=Value1> <commandcode2<::<AVPName2=Value2> <commandcode3></pre> <p>For example, if the sticky session entries need to deleted based on command code '271' with Accounting-Record-Type value as 4, use the format below:</p> <pre>Set StickyDeletionCmdList "271:: Accounting-Record-Type=4"</pre>
Peer Definitions Proxy tab	
Name	Required; name of the peer.
Host Name	Required; hostname or IP address of the peer. The HostName must exist in the client list for the route to be active.
Metric	Required; metric value for this peer entry. The higher the value the lower the preference. The highest value of preference is 0.

Table 4-21 Diameter Service Properties (continued)

Property	Description
Weight	Required; default value is 0. Specifies the weight percentage for which the service needs to load balance the peer. Note When you set the weight to a value other than 0, the weight should be in multiples of 10 and the sum of the weights configured in the peer list should be equal to 100.
IMSIRanges	Required; used for load balancing. The value is set to comma separated values of IMSI Ranges. For example, set IMSIRanges “11215600000001-112156001000000,112156010000001-112156011000000” Note Cisco Prime AR uses the AVP configured in StickyAVP property to check whether the IMSI is in valid range.

M3UA

Cisco Prime AR supports the M3UA service, which is used to fetch MSISDN from IMSI through RADIUS Packets. The M3UA service sends a SendRoutingInfoForLCS(SRIForLCS) request that contains the IMSI information to the remote HLR. The HLR sends the MSISDN in response. To fetch the MSISDN information from IMSI, you need to configure the SIGTRAN-M3UA remote server where Cisco Prime AR is installed, see [Configuring M3UA Service](#) for more information.

The M3UA service checks for IMSI environment variable to fetch the MSISDN information. If there is no IMSI environment variable set, then the **User-Name** in the Radius **Access-Request** is used as IMSI to fetch the MSISDN information. The fetched MSISDN is copied to the [AuthorizationInfo](#) environment variable where you can write a script to copy the environment variable to any attribute of your choice.



Note

M3UA service supports fetching the MSISDN only through SIGTRAN-M3UA interface.

The following shows an example configuration of M3UA service:

```
[ //localhost/Radius/Services/FetchMSISDN ]
  Name = FetchMSISDN
  Description =
  Type = m3ua
  IncomingScript~ =
  OutgoingScript~ =
  OutageScript~ =
  OutagePolicy~ = RejectAll
  RemoteServers/
```

Table 4-22 M3UA Properties

Property	Description
Type	Required; must set to M3UA service.
IncomingScript	Optional; when set, must be the name of a known incoming script. Cisco Prime AR runs the IncomingScript after it receives the response.

Table 4-22 M3UA Properties (continued)

Property	Description
OutgoingScript	Optional; when set, must be the name of a known outgoing script. Cisco Prime AR runs the OutgoingScript just before it sends the proxy request to the remote server.
OutagePolicy	Required; the default is RejectAll. This property defines how Cisco Prime AR handles requests if all servers listed in the RemoteServers properties are unavailable (that is, all remote RADIUS servers are not available). You must set it to one of the following: AcceptAll, DropPacket, or RejectAll.
OutageScript	Optional; set this property to the name of a script. Cisco Prime AR runs the script when an outage occurs. It allows you to create a script that notifies you when the RADIUS server detects a failure.
RemoteServers	Required; an indexed list from 1 to <n>. Each entry in the list is the name of a RemoteServer of type SIGTRAN-M3UA.

Session Managers

You can use Session Managers to track user sessions. The Session Managers monitor the flow of requests from each NAS and detect the session state. When requests come through to the Session Manager, it creates sessions, allocates resources from appropriate Resource Managers, and frees and deletes sessions when users log out.

The Session Manager enables you to allocate dynamic resources to users for the lifetime of their session. You can define one or more Session Managers and have each one manage the sessions for a particular group or company.



Note

Session record size is limited by the operating system (OS) paging size (8 KB in Solaris and 4 KB in Linux). If a request triggers creation of a session that exceeds the OS paging size, the request will be dropped and the session will not be created.



Note

In this release of Cisco Prime AR, the memory capacity is enhanced to store more than 4 million active sessions by storing the active session records in database server instead of storing it in the main memory. The capacity is dependent on the number of attributes that are being captured for each session.



Note

If the disk partition where Cisco Prime AR stores session backing store data (usually the disk partition where Cisco Prime AR is installed, such as `/opt/CSCOar`) is full, the subsequent packets that try to create sessions will be dropped and no sessions will be created due to lack of disk space.

Session Managers use Resource Managers, which in turn, manage a pool of resources of a particular type. [Table 4-23](#) lists the Session Manager properties.

Cisco Prime AR adds IncomingScript, OutGoingScript, and SessionKey properties. The IncomingScript is run as soon as the session is acquired. The OutGoingScript is run just before the session is written to backing store. The SessionKey property sets the session key value for the Session Manager.

Table 4-23 Session Manager Properties

Property	Description
Name	Required; must be unique in the Session Managers list.
Description	Optional description of the Session Manager.
Type	Set to local or remote. Local is the traditional session manager that maintains sessions in memory and has good performance. The remote session manager operates on a remote ODBC database, and its performance is highly dependent on the performance of the ODBC database.
IncomingScript	Optional; name of script to run when the service starts. This script is run as soon as the session is acquired in Cisco Prime AR.
OutgoingScript	Optional; script to be run just before the session is written to backing store.
SessionTimeout	<p>The SessionTimeout property is optional; no value for this property means the session timeout feature is disabled.</p> <p>Used in conjunction with /Radius/Advanced/SessionPurgeInterval for the session timeout feature. Enables the session timeout feature for a Session Manager. If the SessionTimeout property is set to a value under a session manager, all sessions that belong to that session manager will be checked for timeouts at each SessionPurgeInterval. If any sessions have timed out, they will be released, and all resources associated with those sessions are also released.</p> <p>The SessionTimeout property determines the timeout for a session. If the time difference between the current time and the last update time is greater than this property's value, the session is considered to be stale. The last update time of the session is the time at which the session was created or updated.</p> <p>The SessionTimeout value is comprised of a number and a units indicator, as in <i>n units</i>, where a unit is one of minutes, hours, days, or weeks. The default unit is 'days'.</p>
AllowAccountingStartToCreateSession	<p>Set to TRUE by default; start the session when the Cisco Prime AR server receives an Access Accept or an Accounting-Start.</p> <p>When set to FALSE, start the session when the Cisco Prime AR server receives an Access Accept.</p>
Resource Managers	Ordered list of Resource Managers.

Table 4-23 Session Manager Properties (continued)

Property	Description
PhantomSessionTimeOut	<p>Optional; no value for this property means the phantom session timeout feature is disabled.</p> <p>The PhantomSessionTimeOut property is used in conjunction with /Radius/Advanced/SessionPurgeInterval to enable the phantom session timeout feature for Session Manager.</p> <p>If the PhantomSessionTimeOut property is set to a value under a session manager, all sessions that belong to that session manager will be checked for receipt of an Accounting-Start packet. Sessions that do not receive an Accounting-Start packet from creation until its timeout will be released.</p> <p>The PhantomSessionTimeOut value comprises a number and a units indicator, as in <i>n</i> units, where a unit is one of minutes, hours, days, or weeks. The default unit is 'days'</p>
MemoryLimitForRadiusProcess	<p>This property is used to avoid crashing of the radius process. The default value is 3500 Megabytes. This property is under /radius/advanced.</p> <p>When the radius process uses memory more than the configured limit, further sessions are not created and Cisco Prime AR rejects further incoming requests.</p>

Table 4-23 Session Manager Properties (continued)

Property	Description
MemorySizeCheckInterval	This property is used to avoid crashing of the radius process. This is used in conjunction with MemoryLimitForRadiusProcess . The default value is 5 minutes. MemorySizeCheckInterval is a hidden parameter in mcd database. To modify the default value, you need to export the mcd database. Typically, a separate thread is created to monitor the radius process memory usage for every 5 minutes.
SessionKey	<p>SessionKey property is used to set the sessionkey value for the Session Manager.</p> <p>The SessionManager checks whether the environmental variable Session-Key is set or not. If the environmental variable is set, the server uses it as the sessionkey. If environmental variable Session-Key is not set then SessionManager gets the value configured in the SessionKey property under SessionManager.</p> <p>SessionKey can be a combination of attributes separated by colon. The values for those attributes are obtained from the RequestDictionary. If any one of the attribute that is configured for the sessionkey is not present in the RequestDictionary, Cisco Prime AR will drop the request.</p> <p>However, if Session-Key is not set, SessionManager uses NAS-Identifier and NAS-Port to create the sessionkey. An example configuration,</p> <pre>--> set SessionKey "User-Name:NAS-Port"</pre> <p>The following shows the sample configuration of sessionkey for Session Manager:</p> <pre>[//localhost/Radius/SessionManagers/session-mgr-1] Name = session-mgr-1 Description = IncomingScript = OutgoingScript = AllowAccountingStartToCreateSession = TRUE SessionTimeOut = PhantomSessionTimeOut = SessionKey = ResourceManagers/</pre>

You can manage sessions with the two **aregcmd** session management commands: **query-sessions** and **release-sessions**. For more information about these two commands, see the [query-sessions, page 2-9](#) and the [release-sessions, page 2-9](#).

This section contains the following topics:

- [Session Creation](#)
- [Session Notes](#)
- [Soft Group Session Limit](#)
- [Session Correlation Based on User-Defined Attributes](#)

Session Creation

Cisco Prime AR Sessions can be created by two types of RADIUS packets:

- Access-Requests
- Accounting-Requests with an **Acct-Status-Type** attribute with a value of **Start**.

This allows Cisco Prime AR to monitor Sessions even when it is not allocating resources. For example, when Cisco Prime AR is being used as an “Accounting-Only” server (only receiving Accounting requests), it can create a Session for each Accounting “Start” packet it successfully processes. The corresponding Accounting “Stop” request will clean up the Session. Note, if a Session already exists for that NAS/NAS-Port/User (created by an Access-Request), Cisco Prime AR will not create a new one.

When you do not want Cisco Prime AR to create Sessions for Accounting “Start” requests, simply set the **AllowAccountingStartToCreateSession** property on the SessionManager to FALSE.

Session Notes

Session Notes are named text messages attached to a Session and are stored with the Session data, including resources allocated for a specific user session. This data, including Session Notes, can be retrieved and viewed using the **aregcmd** command **query-sessions**.

--> **query-sessions /Radius/SessionManagers/session-mgr-2**

```
sessions for /Radius/SessionManagers/session-mgr-2:
S257 NAS: localhost, NAS-Port:1, User-Name: user1, Time: 00:00:08,
  IPX 0x1, GSL 1, USL 1, NOTES: "Date" "Today is 12/14/98.", "Requested
  IP Address" "1.2.3.4", "Framed-IP-Address" "11.21.31.4"
```

Session Notes can be created by Scripts using the Environment dictionary passed into each or by the Cisco Prime AR server. When more than one Session Note is added, the **Session-Notes** entry should be a comma-separated list of entry names.

Performing a TCL Script

To perform a TCL script:

-
- Step 1** The Script should create an Environment dictionary entry using the Session Note name as the entry name, and the Session Note text as the entry value. For example:

```
$environ put "Date" "Today is 12/15/08"
$environ put "Request IP Address" "1.2.3.4"
```

- Step 2** The Script should create or set an Environment dictionary entry with the name **Session-Notes** with a value that contains the name of the entries created. For example:

```
$environ put "Session-Notes" "Date, Requested_IP_Address"
```

Performing a REX Script

To perform a REX script:

-
- Step 1** The Script should create an Environment dictionary entry using the Session Note name as the entry name, and the Session Note text as the entry value. For example:

```
pEnviron-->put(pEnviron, Date, "Today is 12/15/08.");
pEnviron-->put(pEnviron, Request_IP_Address, "1.2.3.4");
```

- Step 2** The Script should create/set an Environment dictionary entry with the name **Session-Notes** with a value that contains the name of the first entry created. For example:

```
pEnviron-->put (pEnviron, "Session-Notes", "Date, Requested_IP_Address");
```

**Note**

Scripts creating Session Notes must be executed before the Session Management step takes place while processing a packet.

Cisco Prime AR will automatically create a Session Note if a packet is passed to a SessionManager and it already contains a **Framed-IP-Address** attribute in the packet's Response dictionary. This IP address could come from a Profile, RemoteServer response, or from a previously executed script. For example, a Session output containing Session Notes when using the **aregcmd** command **query-session** would be as follows:

```
sessions for /Radius/SessionManagers/session-mgr-2:
  S257 NAS: localhost, NAS-Port:1, User-Name: user1, Time: 00:00:08,
  IPX 0x1, GSL 1, USL 1, NOTES: "Date" "Today is 12/14/08.", "Requested
  IP Address" "1.2.3.4", "Framed-IP-Address" "11.21.31.4"
```

Session Notes are also copied into the Environment dictionary after Session Management. The **Session-Notes** Environment dictionary entry will contain the names of all the Environment dictionary entries containing Session Notes.

In Cisco Prime AR, a major command is introduced—**count-sessions**. The **count-session lr all** command helps to count the total sessions in Cisco Prime AR. The options are similar to the **query-session** command options. The **query-session** command displays cached attributes in addition to session details.

Soft Group Session Limit

Two new environment variables, **Group-Session-Limit** and **Current-Group-Count** (see rex.h), are set if the group session limit resource is allocated for a packet. These variables allow a script to see how close the group is to its session limit; one way to use this information is to implement a script-based soft limit. For example, you could use the Class attribute to mark sessions that have exceeded a soft limit of 80% -- as hard coded in the script (in a Tcl script called from /Radius/OutgoingScript):

```
set softlimit [ expr 0.8 * [ $environ get Group-Session-Limit ] ]
if { [ $environ get Current-Group-Count ] < $softlimit } {
  $response put Class 0
} else {
  $response put Class 1
}
```

**Note**

The soft limit itself is hard coded in the script; soft limits are not directly supported in the server. The action to be taken when the soft limit is exceeded (for example, Class = 1, and then the accounting software branches on the value of Class) is also the responsibility of the script and/or external software.

Session Correlation Based on User-Defined Attributes

All the session objects are maintained in one dictionary keyed by a string. You can define the keying material to the session dictionary through a newly introduced environment variable, **Session-Key**.

If the **Session-Key** is presented at the time of session manager process, it will be used as the key to the session object for this session. The **Session-Key** is of type string. By default, the **Session-Key** is not set. Its value should come from attributes in the incoming packet and is typically set by scripts. For example, CLID can be used to set the value of **Session-Key**.

Use the function `UseCLIDAsSessionKey` as defined in the script `rexscript.c` to specify that the **Calling-Station-Id** attribute that should be used as the session key to correlate requests for the same session. This is a typical case for 3G mobile user session correlation. You can provide your own script to define other attributes as the session key.

In the absence of the **Session-Key** variable, the key to the session will be created based on the string concatenated by the value of the **NAS-Identifier** and the **NAS-Port**.

There is a new option *with-key* available in `aregcmd` for query-sessions and release-sessions to access sessions by **Session-Key**.

Resource Managers

Resource Managers allow you to allocate dynamic resources to user sessions. The following lists the different types of Resource Managers.

- **IP-Dynamic**—manages a pool of IP addresses that allows you to dynamically allocate IP addresses from a pool of addresses
- **IP-Per-NAS-Port**—allows you to associate ports to specific IP addresses, and thus ensure each NAS port always gets the same IP address
- **IPX-Dynamic**—manages a pool of IPX network addresses
- **Subnet-Dynamic**—manages a pool of subnet addresses
- **Group-Session-Limit**—manages concurrent sessions for a group of users; that is, it keeps track of how many sessions are active and denies new sessions after the configured limit has been reached
- **User-Session-Limit**—manages per-user concurrent sessions; that is, it keeps track of how many sessions each user has and denies the user a new session after the configured limit has been reached
- **Home-Agent**—manages a pool of on-demand IP addresses
- **USR-VPN**—manages Virtual Private Networks (VPNs) that use USR NAS Clients.
- **Home-Agent-IPv6**—manages a pool of on-demand IPv6 addresses
- **Remote-IP-Dynamic**—manages a pool of IP addresses that allows you to dynamically allocate IP addresses from a pool of addresses. It internally works with a remote ODBC database.
- **Remote-User-Session-Limit**—manages per-user concurrent sessions; that is, it keeps track of how many sessions each user has and denies the user a new session after the configured limit has been reached. It internally works with a remote ODBC database.
- **Remote-Group-Session-Limit**—manages concurrent sessions for a group of users; that is, it keeps track of how many sessions are active and denies new sessions after the configured limit has been reached. It internally works with a remote ODBC database.

Each Resource Manager is responsible for examining the request and deciding whether to allocate a resource for the user, do nothing, or cause Cisco Prime AR to reject the request.

Table 4-24 lists the Resource Manager properties.

Table 4-24 Resource Manager Properties

Property	Description
Name	Required; must be unique in the Resource Managers list.
Description	Optional; description of the Resource Manager.
Type	Required; must be either Dynamic-DNS , IP-Dynamic , IP-Per-NAS-Port , IPX-Dynamic , Session Cache , Subnet-Dynamic , Group-Session-Limit , Home-Agent , User-Session-Limit , USR-VPN , Home-Agent-IPv6 , Remote-IP-Dynamic , Remote-User-Session-Limit , Remote-Group-Session-Limit or Remote-Session-Cache .

Types of Resource Managers

A number of different types of Resource Managers exist that allow you to manage IP addresses dynamically or statically, limit sessions on a per group or per user basis, or manage a Virtual Private Network. See [Appendix A, “Cisco Prime Access Registrar Tcl, REX and Java Dictionaries,”](#) for information on how to override these individual Resource Managers.



Note

Resource Manager supports the following remote type session managers: `remote-ip-dynamic`, `remote-session-cache`, `home-agent`, `remote-user-session-limit`, `home-agent-ipv6` and `remote-group-session-limit`.

This section contains the following topics:

- [Gateway Subobject](#)
- [Group-Session-Limit](#)
- [Home-Agent](#)
- [Home-Agent-IPv6](#)
- [IP-Dynamic](#)
- [IP-Per-NAS-Port](#)
- [IPX-Dynamic](#)
- [Session-Cache](#)
- [Subnet-Dynamic](#)
- [User-Session-Limit](#)
- [USR-VPN](#)
- [Dynamic-DNS](#)
- [Remote-IP-Dynamic](#)
- [Remote-User-Session-Limit](#)
- [Remote-Group-Session-Limit](#)
- [Remote-Session-Cache](#)

Gateway Subobject

The **Gateway** subobject includes a list of names of the Frame Relay Gateways for which to encrypt the session key.

If you use this Resource Manager, supply the information listed in [Table 4-25](#).

Table 4-25 Gateway Properties

Property	Description
Name	Required; must be unique in the Gateways list.
Description	Optional description of the gateway.
IPAddress	Required; IP address of the gateway.
SharedSecret	Required; must match the shared secret of the gateway.
TunnelRefresh	Optional; if specified it is the number of seconds the tunnel stays active before a secure “keepalive” is exchanged between the tunnel peers in order to maintain the tunnel open.
LocationID	Optional; if specified it is a string indicating the physical location of the gateway.

Group-Session-Limit

Group-Session-Limit allows you to manage concurrent sessions for a group of users; that is, it keeps track of how many sessions are active and denies new sessions after the configured limit has been reached.

When you use this Resource Manager, you must set the GroupSessionLimit property to the maximum number of concurrent sessions for all users.

Home-Agent

Home-Agent is a new resource manager that supports dynamic HA assignment. You configure the home-agent resource manager with a list of IP addresses. The Cisco Prime AR server assigns those addresses to clients whose request dictionary has the right attributes to indicate that an assignment should be done. This is similar to the **ip-dynamic** resource manager.

Unlike the **ip-dynamic** resource manager, HAs are not exclusively allocated to an individual session but are shared among a set of sessions.

Detailed configuration information for the Home-Agent resource manager is found in [Chapter 19, “Wireless Support.”](#) When you use this Resource Manager, you must set the Home-Agent-IPAddresses property to a single IP address or a range of IP addresses.

Home-Agent-IPv6

Home-Agent-IPv6 is a new resource manager used to configure IPv6 address.

IP-Dynamic

IP-Dynamic allows you to manage a pool of IP addresses from which you dynamically allocate IP addresses.

When you use the IP-Dynamic Resource Manager, provide values for the properties listed in [Table 4-26](#).

Table 4-26 IP-Dynamic Properties

Property	Description
NetMask	Required; must be set to a valid net mask.
IPAddresses	Required; must be a list of IP address ranges.
AllowOverlappedIPAddresses	When set to TRUE, this property supports overlapping IP addresses between session managers for VPN users. Default value is FALSE.
ReuseIPForSameSessionKeyAndUse r	When set to FALSE, this property does not reuse IP address resources for a session. Default value is TRUE.

IP-Per-NAS-Port

IP-Per-NAS-Port allows you to associate specific IP addresses with specific NAS ports and thus ensures each NAS port always gets the same IP address.

When you use this Resource Manager, provide values for the properties listed in [Table 4-27](#).



Note

You must have the same number of IP addresses and ports.

Table 4-27 IP-Per-NAS-Port Properties

Property	Description
NetMask	Required; if used, must be set to a valid net mask.
NAS	Required; must be the name of a known Client. This value must be the same as the NAS-Identifier attribute in the Access-Request packet.
IPAddresses	Required; must be a list of IP address ranges.
NASPorts	Required list of NAS ports.

IPX-Dynamic

An **IPX-Dynamic** Resource Manager allows you to dynamically manage a pool of IPX networks. When you use the IPX-Dynamic Resource Manager, you must set the Networks property to a valid set of numbers which correspond to your networks.



Note

You cannot use IPX network number 0x0. If you attempt to configure a Resource Manager with an IPX network number of 0x0, validation will fail.

Session-Cache

The **session-cache** Resource Manager supports the Identity Cache feature. You use session-cache Resource Managers to define the RADIUS attributes to store in cache. Set the QueryKey property to the XML attribute you want to key on such as XML-Address-format-IPv4 and list all attributes to be cached in the AttributesToBeCached subdirectory. Use the QueryMappings subdirectory to map XML attributes to RADIUS attributes.

Table 4-28 Session-Cache Resource Manager Properties

Property	Description
QueryKey	Required; set the QueryKey to the a RADIUS attribute you want to key on, such as Framed-IP-Address. A change made in Cisco Prime AR requires that this attribute not be an XML attribute, even if this session-cache resource manager is being used for an XML query. Note Any existing session-cache resource managers using an XML attribute for the Query Key must be changed to a RADIUS attribute that this XML attribute is mapped to under QueryMappings.
PendingRemovalDelay	Required; length of time information remains in the cache after the session ends (defaults to 10 seconds)
AttributesToBeCached	Required; use this subdirectory to provide a list of RADIUS attributes you want to store in cache
QueryMappings	Required; list of attribute pairs, mapping the XML attributes on the left-hand side to the RADIUS attribute on the right-hand side.



Note

Session record size is limited by the operating system (OS) paging size (8 KB in Solaris and 4 KB in Linux). If a request triggers creation of a session that exceeds the OS paging size, the request will be dropped and the session will not be created.

If the disk partition where Cisco Prime AR stores session backing store data (usually the disk partition where Cisco Prime AR is installed, such as **/opt/CSCOAr**) is full, the subsequent packets that try to create sessions will be dropped and no sessions will be created due to lack of disk space.

Subnet-Dynamic

The **subnet-dynamic** Resource Manager supports the On Demand Address Pool feature. You use subnet-dynamic resource managers to provide pools of subnet addresses. Following is an example of the configuration of a subnet dynamic resource manager:

```
/Radius/ResourceManagers/newResourceMgr
Name = newResourceMgr
Description =
Type = subnet-dynamic
Subnet-Mask = 255.255.255.0
SubnetAddresses/
  10.1.0.0-10.1.10.0
  11.1.0.0-11.1.10.0
```

When you use the subnet-dynamic Resource Manager, provide values for the properties listed in [Table 4-29](#).

Table 4-29 Subnet-Dynamic Properties

Property	Description
Type	Required
Subnet mask	Required; must be set to the size of the managed subnets
SubnetAddresses	Required; must be a valid range of IP addresses

User-Session-Limit

User-Session-Limit allows you to manage per-user concurrent sessions; that is, it keeps track of how many sessions each user has and denies the user a new session after the configured limit has been reached.

When you use the user-session-limit Resource Manager, set the user-session-limit property to the maximum number of concurrent sessions for a particular user.

USR-VPN

USR-VPN allows you to set up a Virtual Private Network (VPN) using a US Robotics NAS.

When you use this Resource Manager, provide values for the properties listed in [Table 4-30](#).

Table 4-30 USR-VPN Properties

Property	Description
Identifier	Required; must be set to the VPN ID the USR NAS will use to identify a VPN.
Neighbor	Optional; if set, should be the IP address of the next hop router for the VPN.
FramedRouting	Optional; if set, should be RIP V2 Off or RIP V2 On if the USR NAS is to run RIP Version 2 for the user.
Gateways	Required to set up a tunnel between the NAS and the Gateways.

Dynamic-DNS

Cisco Prime AR supports the Dynamic DNS protocol providing the ability to update DNS servers.

When you use this Resource Manager, provide values for the properties listed in [Table 4-31](#).

Table 4-31 DYNAMIC-DNS Properties

Fields	Description
Max DNS TTLS	Set the maximum TTL of the DNS record.
DNS Host bytes	Set the number of bytes to be used to construct the reverse zone entry.

Table 4-31 DYNAMIC-DNS Properties (continued)

Fields	Description
Forward Zone Name	Set the name of the forward zone. For a given Resource Manager you must decide which forward zone you will be updating for sessions the resource manager will manage.
Reverse Zone Name	Set the name of the reverse zone.
Forward Zone Server	Set the Server IP of the forward zone
Reverse Zone Server	Set the Server IP of the reverse zone
Forward Zone TSIG KeyS	Server-wide security key to process all forward zone dynamic DNS updates. This is used if a ForwardZoneTSIGKey was not specified on the Resource Manager.
Reverse Zone TSIG Keys	Server-wide security key to process all reverse zone dynamic DNS updates. This is used if a ReverseZoneTSIGKey was not specified on the Resource Manager

Remote-IP-Dynamic

The configuration is same as IP-Dynamic but internally it works with a remote ODBC database.

Remote-User-Session-Limit

The configuration is same as User-Session-Limit but internally it works with a remote ODBC database.

Remote-Group-Session-Limit

The configuration is same as Group-Session-Limit but internally it works with a remote ODBC database.

Remote-Session-Cache

The configuration is same as Session-Cache but it should be used with session manager of type remote.

Profiles

You use Profiles to group RADIUS attributes that belong together, such as attributes that are appropriate for a particular class of PPP or Telnet user. You can reference profiles by name from either the **UserGroup** or the **User** properties. Thus, if the specifications of a particular profile change, you can make the change in a single place and have it propagated throughout your user community.

Although you can use UserGroups or Profiles in a similar manner, choosing whether to use one rather than the other depends on your site. When you require some choice in determining how to authorize or authenticate a user session, then creating specific profiles, and creating a group that uses a script to choose among them is more flexible.

In such a situation, you might create a default group, and then write a script that selects the appropriate profile based on the specific request. The benefit to this technique is each user can have a single entry, and use the appropriate profile depending on the way they log in.

Table 4-32 lists the **Profile** properties.

Table 4-32 Profile Properties

Property	Description
Name	Required; must be unique in the Profiles list.
Description	Optional; description of the profile.
Attributes	Profiles include specific RADIUS attributes that Cisco Prime AR returns in the Access-Accept response.

Attributes

Attributes are specific RADIUS components of requests and responses defined in the Request and Response Attribute dictionaries. Use the **aregcmd** command **set** to assign values to attributes.

For a complete list of the attributes, see [Appendix C, “RADIUS Attributes.”](#) When setting a value for a STRING-type attribute such as Connect-Info (which starts with an integer), you must use the hexadecimal representation of the integer. For example, to set the attribute Connect-Info to a value of 7:7, use a set command like the following:

```
set Connect-Info 37:3A:37
```

Translations

Translations add new attributes to a packet or change an existing attribute from one value to another. The **Translations** subdirectory lists all definitions of **Translations** the RADIUS server can apply to certain packets.

Under the **/Radius/Translations** directory, any translation to insert, substitute, or translate attributes can be added. The following is a sample configuration under the **/Radius/Translations** directory:

```
cd /Radius/Translations
Add T1
cd T1
Set DeleAttrs Session-Timeout, Called-Station-Id
cd Attributes
Set Calling-Station-Id 18009998888
```

DeleAttrs is the set of attributes to be deleted from the packet. Each attribute is comma separated and no spaces are allowed between attributes. All attribute value pairs under the attributes subdirectory are the attributes and values that are going to be added or translated to the packet.

Under the **/Radius/Translations/T1/Attributes** directory, inserted or translated attribute value pairs can be set. These attribute value pairs are either added to the packet or replaced with the new value.

If a translation applies to an Access-Request packet, by referencing the definition of that translation, the Cisco Prime AR server modifies the Request dictionary and inserts, filters and substitutes the attributes accordingly. You can set many translations for one packet and the Cisco Prime AR server applies these translations sequentially.



Note

Later translations can overwrite previous translations.

Table 4-33 lists the Translation properties.

Table 4-33 Translations Properties

Property	Description
Name	Required; must be unique in the Translations list.
Description	Optional; description of the Translation
DeleteAttrs	Optional; lists attributes to be filtered out

TranslationGroups

You can add translation groups for different user groups under **TranslationGroups**. All Translations under the Translations subdirectory are applied to those packets that fall into the groups. The groups are integrated with the Cisco Prime AR Rule engine.

The Cisco Prime AR Administrator can use any RADIUS attribute to determine the **Translation Group**. The incoming and outgoing translation group can be different translation groups. For example, you can set one translation group for incoming translations and one for outgoing translations.

Under the **/Radius/TranslationGroups** directory, translations can be grouped and applied to certain sets of packets, which are referred to in a rule. The following is a sample configuration under the **/Radius/TranslationGroups** directory:

```
cd /Radius/TranslationGroups
Add CiscoIncoming
cd CiscoIncoming
cd Translations
Set 1 T1
```

The translation group is referenced through the Cisco Prime AR Policy Engine in the **/Radius/Rules/<RuleName>/Attributes** directory. **Incoming-Translation-Groups** are set to a translation group (for example `CiscoIncoming`) and **Outgoing-Translation-Groups** to another translation group (for example `CiscoOutgoing`). Table 4-34 lists the Translation Group properties.

Table 4-34 TranslationGroups Properties

Property	Description
Name	Required; must be unique in the Translations list.
Description	Optional; description of the Translation Group
Translations	Lists of translation

Remote Servers

You can use the **RemoteServers** object to specify the properties of the remote servers to which Services proxy requests. **RemoteServers** are referenced by name from the **RemoteServers** list in either the **radius**, **ldap** or **tacacs-udp** Services.

Table 4-35 lists the common **RemoteServers** properties.

Table 4-35 Common RemoteServer Properties

Property	Description
Name	Required; must be unique in the RemoteServers list.
Description	Optional; description of the remote server.
Protocol	Required; specifies the remote server protocol which can be radius , ldap , or tacacs-udp .
IPAddress	Required; this property specifies where to send the proxy request. It is the address of the remote server. You must set it to a valid IP address. The IP address format is enhanced to support IPv6 apart from IPv4 only for the RADIUS type remote server.
Port	Required; the port to which Cisco Prime AR sends proxy requests. You must specify a number greater than zero. If there is no default port number, you must supply the correct port number for your remote server. If you set a port to zero, Cisco Prime AR sets the port to the default value for the type of remote server being configured. For example, the following remote servers have these default port values: dynamic-dns—53 radius—1645 ldap—389 accounting—1646
ReactivateTimerInterval	Required; the amount of time (in milliseconds) to wait before retrying a remote server that was offline. You must specify a number greater than zero. The default is 300,000 (5 minutes).

Types of Protocols

The Remote Server protocol you specify determines what additional information you must provide. The following are the protocols available in Cisco Prime AR with their required and optional fields.

Cisco Prime AR provides the following RemoteServer protocol types:

- [Domain Authentication](#)
- [Dynamic DNS](#)
- [LDAP](#)
- [Map-Gateway](#)
- [Sigtran](#)
- [ODBC](#)
- [ODBC-Accounting](#)
- [OCI](#)
- [OCI-Accounting](#)
- [Prepaid-CRB](#)

- [Prepaid-IS835C](#)
- [RADIUS](#)
- [SIGTRAN-M3UA](#)
- [Rules](#)

Domain Authentication

The domain-auth Remote Server is used with the Windows Domain Authentication feature. Cisco Prime AR supports the Windows Domain Controller/Active Directory (WDC/AD) and enables you to authenticate users present in a WDC/AD using the CiscoSecure Remote Agent (CSRA).



Note

To get the CiscoSecure Remote Agent software package, please send an email to ar-tme@cisco.com.

During authentication, the user credentials are sent to the CSRA, which authenticates the credentials with the WDC/AD. The user optionally can specify the domain name along with their UserID when they log in. If the domain is not specified, authentication is first performed with the local WDC/AD (default domain as specified in the remote server configuration), then with all the other trusted domain controllers, one by one until the user is found in any of the trusted WDC/ADs.

This *failover* to other domains is taken care by the local (default) WDC/AD. The local WDC/AD maintains a list of trusted domains and when the user is not found in the local AD, the WDC queries the trusted WDC/ADs, to see if any one of those had the user in it. If any of the WDC/ADs has the user, those credentials would be used to authenticate the user.

The WDC/AD authentication stops at the first *hit* and does not check other domains even if the user credentials do not match (resulting in an authentication failure). When a domain is specified, authentication is performed only on that domain. This domain should be either the local WDC/AD or one of the trusted WDC/ADs.

A 128-bit Blowfish (variant) encryption algorithm secures the communication between the Cisco Prime AR and CSRA. The session key for this encryption is negotiated when the connection is established.

The following is the default configuration of a domain-auth Remote Server.

```
[ //localhost/Radius/RemoteServers/domain-auth ]
  Name = newone
  Description =
  Protocol = domain-auth
  HostName =
  Port = 2004
  ReactivateTimerInterval = 300000
  DefaultDomain =
  Timeout = 15
  AgentConnections = 15
  DefaultUserGroup =
  GroupMaps/
```

Table 4-36 lists and defines the domain-auth RemoteServer properties.

Table 4-36 Domain Authentication RemoteServer Properties

Property	Description
HostName	Required; hostname or IP address of the remote server.
Port	Required; port used for communication with WDC/AD; defaults to 2004.

Table 4-36 Domain Authentication RemoteServer Properties (continued)

Property	Description
ReactivateTimerInterval	Required; default is 300,000 milliseconds. Specifies the length of time to wait before attempting to reconnect if a thread is not connected to a data source.
DefaultDomain	Species the default domain for authentication if the user does not include a domain during log in. Otherwise, authentication is performed on the local domain.
Timeout	Required; defaults to 15.
AgentConnections	Required; default is 15. Represents the total number of connections Cisco Prime AR can open with the CSRA.
DefaultUserGroup	User group to be used when no mapping is found in the list of maps in the GroupMap property or when there is no hit in the groups listed in GroupMaps. The DefaultUserGroup is used to authorize users that are authenticated by this domain-auth RemoteServer.
GroupMaps	A list of groups to which the user belongs in the WDC/AD mapped to an internal group in the Cisco Prime AR server. Entries are of the form: <ol style="list-style-type: none"> 1. "InternalGroup1 = ExternalGroup1, ExternalGroup2, ..." 2. "InternalGroup2 = ExternalGroup3, ExternalGroup4, ..." To configure group mappings, use the following syntax: <p style="text-align: center;">set 1 "Group1 = ExternalGroup1,ExternalGroup2, ExternalGroup3"</p>

Users can optionally be authorized using WDC/AD using a list of groups the user belongs to in WDC/AD. This list of groups is mapped to an internal group in the Cisco Prime AR server using the GroupMaps property. An optional default group can also be configured using the DefaultUserGroup property.

When a hit is made, the corresponding group is taken, even if there might be a better match further down the list. For example, if the user is part of groups A, B, C, and D, and if a map for Groups A, B, and C is listed before a map for Groups A, B, C, and D, the map for Groups A, B, and C will be taken. This requires the administrator to configure more specific mapping before the general mapping.

The list of groups from the WDC/AD is copied to a new environment variable named Windows-Domain-Groups to permit mapping to a more appropriate group at the next relevant scripting point.

Dynamic DNS

The **dynamic-dns** RemoteServer is used with the Dynamic DNS feature. The following is the default configuration of a dynamic-dns RemoteServer.

```
[ //localhost/Radius/RemoteServers/ddns ]
  Name = ddns
  Description =
  Protocol = dynamic-dns
  IPAddress =
  Port = 53
  MaxTries = 3
  InitialTimeout = 2000
```

```

MaxDNSRenamingRetries = 3
TrimHostName = TRUE
ForwardZoneTSIGKey =
ReverseZoneTSIGKey =

```

Table 4-37 lists and defines the dynamic-dns RemoteServer properties.

Table 4-37 Dynamic-DNS RemoteServer Properties

Property	Description
IPAddress	The IPAddress address of the DNS server
Port	Port 53 is the port that most DNS servers will use as a default
MaxTries	Number of times the server tries to send dynamic updates to a DNS server
InitialTimeout	Time, in milliseconds, that the server waits for a response before retrying a dynamic DNS request
MaxRenamingRetries	Number of times that the dynamic-dns resource managers can try to add a host in DNS even if it detects that the host's name is already present. This controls the number of times Cisco Prime AR tries to modify a host's name to resolve a conflict on each failed update.
TrimHostName	Controls whether Cisco Prime AR trims the hostname string to the first period character (used to update dynamic DNS update records and to return the hostname option to clients). If this attribute is enabled, the hostname is truncated before the period. If disabled, the server retains the period characters in the hostname.
ForwardZoneTSIGKey	Server-wide security key to process all forward zone dynamic DNS updates. This is used if a ForwardZoneTSIGKey was not specified on the Resource Manager.
ForwardZoneTSIGKey	Server-wide security key to process all forward zone dynamic DNS updates. This is used if a ForwardZoneTSIGKey was not specified on the Resource Manager.
ReverseZoneTSIGKey	Server-wide security key to process all reverse zone dynamic DNS updates. This is used if a ReverseZoneTSIGKey was not specified on the Resource Manager.

LDAP

ldap specifies an LDAP server. When you specify the **ldap** protocol, provide the information listed in Table 4-38.

For any LDAP remote service, the server might perform the environment mappings at any time. This means that if the service is set to either authentication and authorization, authentication-only, or authorization-only, environment mappings will take place. RADIUS mappings will take place only if the service is set to perform authorization. Checkitem mappings will take place only if the service is set to perform authentication. Previously environment mappings only occurred when the service was set for both authentication and authorization. RADIUS mappings, environment mappings, and checkitem mappings will not take place, if bind-based authentication is enabled.

Table 4-38 *Idap RemoteServer Properties*

Property	Description
Port	Required; defaults to port 389.
Timeout	Required; the default is 15. The timeout property indicates how many seconds the RADIUS server will wait for a response from the LDAP server. Note Use InitialTimeout from above as a template, except this is timeout is specified in seconds.
HostName	Required; the LDAP server's hostname or IP address.
BindName	Optional; the distinguished name (dn) to use when establishing a connection between the LDAP and RADIUS servers.
BindPassword	Optional; the password associated with the BindName .
SearchPath (Overridden by Search-Path environment variable)	Required; the path that indicates where in the LDAP database to start the search for user information.
Filter	Required; this specifies the search filter Cisco Prime AR uses when querying the LDAP server for user information. When you configure this property, use the notation "%s" to indicate where the user ID should be inserted. For example, a typical value for this property is "(uid=%s)," which means that when querying for information about user joe, use the filter uid=joe.
UserPasswordAttribute	Required; this specifies which LDAP field the RADIUS server should check for the user's password.
LimitOutstandingRequests	Required; the default is FALSE. Cisco Prime AR uses this property in conjunction with the MaxOutstandingRequests property to tune the RADIUS server's use of the LDAP server. When you set this property to TRUE, the number of outstanding requests for this RemoteServer is limited to the value you specified in MaxOutstandingRequests . When the number of requests exceeds this number, Cisco Prime AR queues the remaining requests, and sends them as soon as the number of outstanding requests drops to this number.
MaxOutstandingRequests	Required when you have set the LimitOutstandingRequests to TRUE. The number you specify, which must be greater than zero, determines the maximum number of outstanding requests allowed for this remote server.

Table 4-38 Idap RemoteServer Properties (continued)

Property	Description
MaxReferrals	<p>Required; must be a number equal to or greater than zero. This property indicates how many referrals are allowed when looking up user information. When you set this property to zero, no referrals are allowed.</p> <p>Cisco Prime AR manages referrals by allowing the RADIUS server's administrator to indicate an LDAP "referral attribute," which might or might not appear in the user information returned from an LDAP query. When this information is returned from a query, Cisco Prime AR assumes it is a referral and initiates another query based on the referral. Referrals can also contain referrals.</p> <p>Note This is an LDAP v2 referral property.</p>
ReferralAttribute	<p>Required when you have specified a MaxReferrals value. This property specifies which LDAP attribute, returned from an LDAP search, to check for referral information.</p> <p>Note This is an LDAP v2 referral property.</p>
ReferralFilter	<p>Required when you have specified a MaxReferral value. This is the filter Cisco Prime AR uses when processing referrals. When checking referrals, the information Cisco Prime AR finds in the referral itself is considered to be the search path and this property provides the filter. The syntax is the same as that of the Filter property.</p> <p>Note This is an LDAP v2 referral property.</p>
PasswordEncryptionStyle	The default is None . You can also specify crypt, dynamic, SHA-1, and SSHA-1 .
EscapeSpecialCharInUserName	FALSE by default
DNSLookupAndLDAPRebindInterval	Specifies the timeout period after which the Cisco Prime AR server will attempt to resolve the LDAP hostname to IP address (DNS resolution); 0 by default
DataSourceConnections	Specifies the number of concurrent connections to the LDAP server. The default value is 8.
SearchScope	<p>Specifies how deep to search within a search path; default is <i>SubTree</i> which indicates a search of the base object and the entire subtree of which the base object distinguished name is the highest object.</p> <p><i>Base</i> indicates a search of the base object only.</p> <p><i>OneLevel</i> indicates a search of objects immediately subordinate to the base object, but does not include the base object.</p>

Table 4-38 *Idap RemoteServer Properties (continued)*

Property	Description
LDAPToRadiusMappings	<p>Optional; a list of name/value pairs in which the name is the name of the ldap attribute to retrieve from the user record, and the value is the name of the RADIUS attribute to set to the value of the ldap attribute retrieved.</p> <p>For example, when the LDAPToRadiusMappings has the entry: FramedIPAddress = Framed-IP-Address, the RemoteServer retrieves the FramedIPAddress attribute from the ldap user entry for the specified user, uses the value returned, and sets the Response variable Framed-IP-Address to that value.</p>
LDAPToEnvironmentMappings	<p>Optional; a list of name/value pairs in which the name is the name of the ldap attribute to retrieve from the user record, and the value is the name of the Environment variable to set to the value of the ldap attribute retrieved.</p> <p>For example, when the LDAPToEnvironmentMappings has the entry: group = User-Group, the RemoteServer retrieves the group attribute from the ldap user entry for the specified user, uses the value returned, and sets the Environment variable User-Group to that value.</p>
LDAPToCheckItemMappings	<p>Optional; a list of LDAP <i>attribute/value</i> pairs which must be present in the RADIUS access request and must match, both name and value, for the check to pass.</p> <p>For example, when the LDAPToCheckItemMappings has the entry: group = User-Group, the Access Request must contain the attribute group, and it must be set to User-Group.</p>
UseSSL	<p>A boolean field indicating whether you want Cisco Prime AR to use SSL (Secure Socket Layer) when communicating with this RemoteServer. When you set it to TRUE, be sure to specify the CertificateDBPath field in the Advanced section, and be sure the port you specified for this RemoteServer is the SSL port used by the LDAP server.</p>
UseBinaryPasswordComparison	<p>A boolean field that enables binary password comparison for authentication. This property when set to TRUE, enables binary password comparison. By default, this property is set to FALSE.</p>
UseBindBasedAuthentication	<p>A boolean field that enables bind-based authentication with LDAP server. This property when set to TRUE, enables bind-based authentication. By default, this property is set to FALSE. When set to FALSE, it uses existing legacy authentication method.</p>

Map-Gateway

The following is the default configuration of a map gateway RemoteServer.

```
[ //localhost/Radius/RemoteServers/map-gateway ]
  Name = map-gateway
  Description =
  Protocol = map-gateway
  IPAddress =
  Port = 0
```

```

ReactivateTimerInterval = 300000
SharedSecret =
MaxTries = 3
InitialTimeout = 2000

```

Sigtran

The following is the default configuration of a Sigtran RemoteServer.

```

[ //localhost/Radius/RemoteServers/rs ]
Name = rs
Description =
Protocol = sigtran
HostName =
LocalSubSystemNumber =
CgPAGlobalTitleAddress =
SetOPCInCgPA =
GlobalTitleTranslationScript~ =
SUAConfigurationFilename =
ReactivateTimerInterval =
Timeout = 5000
LimitOutstandingRequests = FALSE
MaxOutstandingRequests = 0

```



Note

The RPM packages such as lksctp-tools-1.0.10-1, lksctp-tools-doc-1.0.10-1 and lksctp-tools-devel-1.0.10-1 should be installed in Linux 5.3 before configuring sigtran remote server which eventually adds the sctp libs (libsctp.so.1.0.10).

The following files can be downloaded from <http://lksctp.sourceforge.net/>

- lksctp-tools-1.0.10-1.i386.rpm
- lksctp-tools-devel-1.0.10-1.i386.rpm
- lksctp-tools-doc-1.0.10-1.i386.rpm

Cisco Prime AR supports only:

- one object of Remoteserver with protocol type "sigtran"
- MAP version 3 (3GPP TS 29.002 V6.4.0 (2003-12)) and ITU Q.773 TCAP

Only one Quintets is fetched from HLR. The ITU TCAP continue message is not supported.

[Table 4-39](#) lists and defines the Sigtran RemoteServer properties.

Table 4-39 Sigtran RemoteServer Properties

Property	Description
HostName	Required; represents the IP address of remote Signalling Gateway specified in the SUAConfiguration file.
LocalSubSystemNumber	Required; the default value for this property is 0. This represents the subsystem number used by SUA user.
CgPAGlobalTitleAddress	Required; represents the Global Title Address of CallingPartyAddress.
SetOPCInCgPA	Required; if it is set to TRUE, OPC will be used in CallingPartyAddress.

Table 4-39 Sigtran RemoteServer Properties (continued)

Property	Description
GlobalTitleTranslationScript	This is used to specify the name of script which is responsible for translating IMSI to GTA.
SUAConfigurationFilename	Required; used to specify the name of configuration file for SUA stack initialization.
ReactivateTimerInterval	Required; represents the reactivate time interval to re-connect after failure.
Timeout	Required; represents the how long the remote server should wait before marking the request as timedout.
LimitOutstandingRequests	Limits the outstanding request to HLR when it is set to TRUE.
MaxOutstandingRequests	This represents the maximum outstanding request to HLR.

**Note**

You should restart the Cisco Prime AR server, if you change any SIGTRAN related configuration.

ODBC

odbc specifies an ODBC server. Cisco Prime AR provides a RemoteServer object (and a service) to support Open Database Connectivity (ODBC), an open specification that provides application developers a vendor-independent API with which to access data sources. [Table 4-40](#) lists the **odbc** server attributes.

For any ODBC remote service, the server might perform the environment mappings at any time. This means that if the service is set to either authentication and authorization, authentication-only, or authorization-only, environment mappings will take place. RADIUS mappings will take place only if the service is set to perform authorization. Checkitem mappings will take place only if the service is set to perform authentication. Previously environment mappings only occurred when the service was set for both authentication and authorization.

Table 4-40 odbc Properties

Property	Description
Timeout	Required; the default is 15. The timeout property indicates how many seconds the RADIUS server will wait for a response from the LDAP server. Note Use InitialTimeout from above as a template, except this is timeout is specified in seconds.
Protocol	Must be set to odbc .
ReactivateTimerInterval	Required; default is 300,000 milliseconds. Length of time to wait before attempting to reconnect if a thread is not connected to a data source.
Data Source Connections	Required; default is 8. This represents the total number of connections Cisco Prime AR can open with the ODBC server; total number of threads Cisco Prime AR can create for the ODBC server.

Table 4-40 *odbc Properties (continued)*

Property	Description
ODBCDataSource	Required; defines all items required for the odbc.ini file. The Cisco Prime AR server automatically creates the odbc.ini file based on these settings.
SQLDefinition	<p>SQLDefinition properties define the SQL you want to execute.</p> <p>Type—query (Cisco Prime AR supports only type query).</p> <p>SQL—SQL query used to acquire the password</p> <p>UserPasswordAttribute—Defines the database column name for the user's password.</p> <p>MarkerList—Defines all markers for the query. MarkerList uses the format UserName/SQL_DATA_TYPE.</p>
ODBCToRadiusMappings	<p>Optional; a list of name/value pairs in which the name is the name of the odbc attribute to retrieve from the user record, and the value is the name of the RADIUS attribute to set to the value of the odbc attribute retrieved.</p> <p>For example, when the ODBCToRadiusMappings has the entry: FramedIPAddress = Framed-IP-Address, the RemoteServer retrieves the FramedIPAddress attribute from the odbc user entry for the specified user, uses the value returned, and sets the Response variable Framed-IP-Address to that value.</p>
ODBCToEnvironmentMappings	<p>Optional; a list of name/value pairs in which the name is the name of the odbc attribute to retrieve from the user record, and the value is the name of the Environment variable to set to the value of the odbc attribute retrieved.</p> <p>For example, when the ODBCToEnvironmentMappings has the entry: group = User-Group, the RemoteServer retrieves the group attribute from the odbc user entry for the specified user, uses the value returned, and sets the Environment variable User-Group to that value.</p>
ODBCToCheckItemMappings	<p>Optional; a list of ODBC <i>attribute/value</i> pairs which must be present in the RADIUS access request and must match, both name and value, for the check to pass.</p> <p>For example, when the ODBCToCheckItemMappings has the entry: group = User-Group, the Access Request must contain the attribute group, and it must be set to User-Group.</p>

ODBC-Accounting

If you use the Oracle Accounting feature, you must configure an ODBC-Accounting RemoteServer object. [Table 4-41](#) lists and defines the ODBC-Accounting RemoteServer properties.

Table 4-41 ODBC-Accounting RemoteServer Properties

Property	Description
Name	Name of the remote server; this property is mandatory, and there is no default
Description	Optional description of server
Protocol	Must be set to odbc-accounting
ReactivateTimerInterval	Mandatory time interval (in milliseconds) to activate an inactive server; defaults to 300000 ms.
Timeout	Mandatory time interval (in seconds) to wait for SQL operation to complete; defaults to 15 seconds
DataSourceConnections	Mandatory number of connections to be established; defaults to 8
ODBCDataSource	Name of the ODBCDataSource to use and must refer to one entry in the list of ODBC datasources configured under /Radius/Advanced/ODBCDataSources . Mandatory; no default
KeepAliveTimerInterval	Mandatory time interval (in milliseconds) to send a keepalive to keep the idle connection active; defaults to zero (0) meaning the option is disabled
BufferAccountingPackets	Mandatory, TRUE or FALSE, determines whether to buffer the accounting packets to local file, defaults to TRUE which means that packet buffering is enabled. Note When set to TRUE, a constant flow of incoming accounting packets can fill the buffer backing store files in /cisco-ar/data/odbc beyond the size configured in MaximumBufferFileSize . Configure BackingStoreDiscThreshold in /Radius/Advanced when using ODBC accounting. See Advanced, page 4-58 for information about how to configure BackingStoreDiscThreshold .
MaximumBufferFileSize	Mandatory if BufferAccountingPackets is set to TRUE, determines the maximum buffer file size, defaults to 10 Megabyte)
NumberOfRetriesForBufferdPacket	Mandatory if BufferAccountingPackets is set to TRUE. A number greater than zero determines the number of attempts to be made to insert the buffered packet into Oracle. Defaults to 3.

OCI

OCI service can be used to authenticate and authorize an access request by querying user information through OCI and to insert accounting records into a data store through OCI. For more information on OCI server properties, see [ODBC/OCI, page 3-104](#).

OCI-Accounting

If you use the Oracle Accounting feature, you must configure an OCI-Accounting RemoteServer object. For more information, see [ODBC/OCI-Accounting, page 3-107](#).

Prepaid-CRB

The following is the default configuration of a prepaid-crb RemoteServer. The Filename property is the name of the required shared library provided by the billing vendor. See [CRB Prepaid Billing, page 16-7](#) for more information on Prepaid -CRB.

```
[ //localhost/Radius/RemoteServers/prepaid-crb ]
  Name = prepaid-crb
  Description =
  Protocol = prepaid-crb
  IPAddress =
  Port = 0
  Filename =
  Connections = 8
```

Prepaid-IS835C

The following is the default configuration of a prepaid-is835c RemoteServer. The Filename property is the name of the required shared library provided by the billing vendor. See [IS835C Prepaid Billing, page 16-2](#) for more information on Prepaid -IS835C.

```
[ //localhost/Radius/RemoteServers/prepaid-is835c ]
  Name = prepaid-is835c
  Description =
  Protocol = prepaid-is835c
  IPAddress =
  Port = 0
  Filename =
  Connections = 8
```

RADIUS

radius specifies a RADIUS server. When you specify the **radius** protocol, supply the information in [Table 4-42](#).

Table 4-42 RADIUS Properties

Property	Description
SharedSecret	Required; the secret shared between the remote server and the RADIUS server.
IncomingScript	Optional; when set, must be the name of a known incoming script. Cisco Prime AR runs the IncomingScript after it receives the response.
OutgoingScript	Optional; when set, must be the name of a known outgoing script. Cisco Prime AR runs the OutgoingScript just before it sends the proxy request to the remote server.
Vendor	Optional; when set, must be the name of a known Vendor.
MaxTries	Required; the number of times to send a proxy request to a remote server before deciding the server is offline. You must specify a number greater than zero. The default is 3.

Table 4-42 RADIUS Properties (continued)

Property	Description
InitialTimeout	Required: represents the number of milliseconds used as a timeout for the first attempt to send a specific packet to a remote server. For each successive retry on the same packet, the previous timeout value used is doubled. You must specify a number greater than zero. The default value is 2000 (or 2 seconds).
ACKaccounting	When ACKAccounting is TRUE, the Cisco Prime AR server waits for the Accounting-Response from the remote RADIUS server before sending the corresponding Accounting-Response to the client. When ACKAccounting is FALSE, the Cisco Prime AR server does not wait for the Accounting-Response and immediately returns an Accounting-Response to the client.

SIGTRAN-M3UA

Cisco Prime AR supports SIGTRAN-M3UA to fetch the authentication vectors from HLR, which is required for EAP-AKA/EAP-SIM authentication. For more information on SIGTRAN-M3UA protocol, see [Chapter 22, “SIGTRAN-M3UA”](#).

Rules

A Rule is a function that selects services based on all input information used by the function.

Advanced

Advanced objects let you configure system-level properties and the Attribute dictionary. Under normal system operation, you should not need to change the system-level properties.



Note

The notation *required* means Cisco Prime AR needs a value for this property. For most of these properties, you can use system defaults.

[Table 4-43](#) lists the **Advanced** properties.

Table 4-43 **Advanced Object Properties**

Property	Description
LogServerActivity	Required; the default is FALSE, which means Cisco Prime AR logs all responses except Access-Accepts and Access-Challenges. Accepting the default reduces the load on the server by reducing that amount of information it must log. Note, the client is probably sending accounting requests to an accounting server, so the Access-Accept requests are being indirectly logged. When you set it to TRUE, Cisco Prime AR logs all responses to the server log file.
MaximumNumberOfRadiusPackets	Required; the default is 8192. This is a critical property you should set high enough to allow for the maximum number of simultaneous requests. When more requests come in than there are packets allocated, Cisco Prime AR will drop those additional requests.
PerPacketHeapSize	Required; the default is 6500. This property sets the size of the initial heap for each packet. The heap is the dynamic memory a request can use during its lifetime. By preallocating the heap size at the beginning of request processing, we can minimize the cost of memory allocations. If PerPacketHeapSize is too low, Cisco Prime AR will ask the system for memory more often. If PerPacketHeapSize is too high, Cisco Prime AR will allocate too much memory for the request causing the system to use more memory than required.
UDPPacketSize	Required; the default is 4096. RFC 2138 specifies the maximum packet length can be 4096 bytes. Do not change this value.
RequireNASsBehindProxyBeInClientList	Required; the default is FALSE. If you accept the default, Cisco Prime AR only uses the source IP address to identify the immediate client that sent the request. Leaving it FALSE is useful when this RADIUS Server should only know about the proxy server and should treat requests as if they came from the proxy server. This might be the case with some environments that buy bulk dial service from a third party and thus do not need to, or are unable to, list all of the NASs behind the third party's proxy server. When you set it to TRUE, you must list all of the NASs behind the Proxy in the Clients list. For more information about this property, see Using the RequireNASsBehindProxyBeInClientList Property, page 4-71 .

Table 4-43 Advanced Object Properties (continued)

Property	Description
AAAFServiceSyncInterval	Required; specified in milliseconds, the default is 75. This property governs how often the file AAA service processes accounting requests and writes the accounting records to the file. You can lower the number to reduce the delay in acknowledging the Account-Request at the expense of more frequent flushing of the accounting file to disk. You can raise the number to reduce the cost of flushing to disk, at the expense of increasing the delays in acknowledging the Accounting-Requests . The default value was determined to provide a reasonable compromise between the two alternatives.
SessionBackingStoreSynchronizationInterval	Required; specified in milliseconds, the default is 100. If you change this value it must be a number greater than zero. This property governs how often the Session Manager backing store writes updated session information to disk. You can lower the number to reduce the delay in acknowledging requests at the expense of more frequent flushing of the file containing the session data to disk. You can raise the number to reduce the cost of flushing to disk at the expense of increasing delays in acknowledging requests. The default value was determined to provide a reasonable compromise between the two alternatives.
BackingStoreDiscThreshold	Required; the default is 10 gigabytes. The value of BackingStoreDiscThreshold is made up of a number of units which can be K, kilobyte, or kilobytes, M, megabyte, or megabytes, or G, gigabyte, or gigabytes. BackingStoreDiscThreshold is used with session management and ODBC accounting and ensures that any data log files generated will not cross the BackingStoreDiscThreshold.
SessionBackingStorePruneInterval	Required; specifies the sleep time interval of the session backing store pruning thread. The recommended and default value is 6 hours, but you can modify this based on the traffic patterns you experience. With SessionBackingStorePruneInterval set to 6 hours, pruning will occur 6 hours after you restart or reload the Cisco Prime AR server and recur every 6 hours. You can set a very low value for this property to make pruning continuous, but there might not be enough data accumulated for the pruning to occur and pruning might be less effective compared to the default setting.

Table 4-43 Advanced Object Properties (continued)

Property	Description
PacketBackingStorePruneInterval	<p>Required; specifies the sleep time interval of the packet backing store pruning thread. The recommended value is 6 hours, but you can modify this based on the traffic patterns you experience.</p> <p>When PacketBackingStorePruneInterval is set to 6 hours, pruning will occur 6 hours after you restart or reload the Cisco Prime AR server and recur every 6 hours.</p> <p>You can set a very low value for this property to make pruning continuous, but there might not be enough data accumulated for the pruning to occur and pruning might be less effective compared to the default setting.</p>
RemoteLDAPServiceThreadTimerInterval	<p>Required; specified in milliseconds, the default is 10. This property governs how often the ldap RemoteServer thread checks to see if any results have arrived from the remote LDAP server. You can modify it to improve the throughput of the server when it proxies requests to a remote LDAP server.</p>
InitialBackgroundTimerSleepTime	<p>Required; the default is 5. This property specifies the amount of time the time queue should initially sleep before beginning processing. This property is only used for initial synchronization and should not be changed.</p>
MinimumSocketBufferSize	<p>Required; the default is 65536 (64 K). This property governs how deep the system's buffer size is for queueing UDP datagrams until Cisco Prime AR can read and process them. The default is probably sufficient for most sites. You can, however, raise or lower it as necessary.</p>
CertificateDBPath	<p>Required if you are using an LDAP RemoteServer and you want Cisco Prime AR to use SSL when communicating with that LDAP RemoteServer. This property specifies the path to the directory containing the client certificates to be used when establishing an SSL connection to an LDAP RemoteServer. This directory must contain the cert7.db and cert5.db certificates and the key3.db and key.db files database used by Netscape Navigator 3.x (and above) or the ServerCert.db certificate database used by Netscape 2.x servers.</p>

Table 4-43 Advanced Object Properties (continued)

Property	Description
LogFileSize	<p>Required; the default is 1 Megabyte. This property specifies the maximum size of the RADIUS server log file. The value for the LogFileSize field is a string composed of two parts; a number, and a units indicator (<n> <units>) in which the unit is one of: K, kilobyte, kilobytes, M, megabyte, megabytes, G, gigabyte, or gigabytes.</p> <p>The LogFileSize property does not apply to the config_mcd_1_log or agent_server_1_log files. See Modifying File Sizes for Agent Server and MCD Server Logs, page 28-3 to configure these files.</p> <p>Note This does not apply to the trace log.</p>
LogFileCount	<p>Required; the default is 2. This property specifies the number of log files to be kept on the system. A new log file is created when the log file size reaches LogFileCount.</p> <p>The LogFileCount property does not apply to the config_mcd_1_log or agent_server_1_log files. See Modifying File Sizes for Agent Server and MCD Server Logs, page 28-3 to configure these files.</p>
TraceFileSize	<p>Required; the default is 1 GB. This property specifies the size of the trace files to be kept on the system. A new trace file is created when the trace file size reaches TraceFileSize. The value for the TraceFileSize field is a string composed of two parts; a number, and a units indicator (<n> <units>) in which the unit is one of: K, kilobyte, kilobytes, M, megabyte, megabytes, G, gigabyte, or gigabytes.</p>
TraceFileCount	<p>Required; this value can be set from 1-100, and the default is 2. This property specifies the number of trace files to maintain. A value of 1 indicates that no file rolling occurs.</p>
UseAdvancedDuplicateDetection	<p>Required; the default is FALSE. Set this property to TRUE when you want Cisco Prime AR to use a more robust duplicate request filtering algorithm. For more information on this property, see Advance Duplicate Detection Feature, page 4-72.</p>
AdvancedDuplicateDetectionMemoryInterval	<p>Required when the Advanced Duplicate Detection feature is enabled. This property specifies how long (in milliseconds) Cisco Prime AR should remember a request. You must specify a number greater than zero. The default is 10,000.</p>

Table 4-43 Advanced Object Properties (continued)

Property	Description
DetectOutOfOrderAccountingPackets	<p>Optional; used to detect accounting packets that arrive out of sequential order. The default is FALSE. This property is useful when using accounting and session management in a RADIUS proxy service.</p> <p>When the DetectOutOfOrderAccountingPacket property is enabled (set to TRUE), a new <i>Class</i> attribute is included in all outgoing Accept packets. The value for this Class attribute will contain the session magic number. The client will echo this value in the accounting packets, and this will be used for comparison.</p> <p>The session magic number is a unique number created for all sessions when the session is created or reused and the DetectOutOfOrderAccountingPacket property is set to TRUE. The DetectOutOfOrderAccountingPacket property is used to detect out-of-order Accounting-Stop packets in roaming scenarios by comparing the session magic number value in the session with the session magic number value contained in the Accounting packet.</p> <p>The value of 0xffffffff is considered by the Cisco Prime AR server to be a wild card magic number. If any accounting stop packets contain the value of 0xffffffff, it will pass the session magic validation even if the session's magic number is some thing else.</p> <p>The format of the class attribute is as follows:</p> <pre><4-byte Magic Prefix><4-byte server IP address><4-byte Magic value></pre>
DefaultReturnedSubnetSizeIfNoMatch	<p>Optional; used with the ODAP feature and reflects the returned size of the subnet if no matched subnet is found. There are three options to select if an exactly matched subnet does not exist: Bigger, Smaller, and Exact. The default is Bigger.</p>
ClasspathForJavaExtensions	<p>A string which is the classpath to be used to locate Java classes and jar files containing the classes required for loading the Java extensions, either Java extension points or services.</p> <p>Note The classpath will always contain the directory \$INSTALLDIR/scripts/radius/java and all of the jar files in that directory.</p>
JavaVMOptions	<p>A string that can contain options to be passed to the JRE upon startup. JavaVMOptions should be used only when requested by Cisco TAC.</p>
MaximumODBCResultSize	<p>Specifies maximum size in bytes for an ODBC mapping. This parameter affects both ODBC result sizes and the trace log buffer for tracing script calls that access any of the dictionaries. (Default value is 256.)</p>

Table 4-43 Advanced Object Properties (continued)

Property	Description
ARIsCaseInsensitive	<p>When set to FALSE, requires that you provide exact pathnames with regard to upper and lower case for all objects, subobjects, and properties. The default setting, TRUE, allows you to enter paths such as <code>/rad/serv</code> instead of <code>/Rad/Serv</code>.</p> <p>Note Cisco Prime AR always authenticates the RADIUS attribute User-Name with regard to upper and lower case, regardless of the setting of this flag.</p>
RemoteRadiusServerInterface	When set, specifies the local interface to bind to when creating the RemoteRadiusServer socket. If not set, the Cisco Prime AR binds to IPADDR_ANY.
ODBCEnvironmentMultiValueDelimiter	Optional; allows you to specify a character that separates multivalued attributes in the marker list when using Oracle (or ODBC) accounting
PacketBackingStoreSyncInterval	The minimum value is 1 and the maximum is a 32-bit unsigned integer. The default is 75.
ListenForDynamicAuthorizationRequests	Must be set to TRUE when using the Change of Authorization (CoA) feature or Packet of Disconnect (POD) feature. Default is FALSE.
MaximumNumberOfXMLPackets	Required when using identity caching. Indicates the maximum number of XML packets to be sent or received. The minimum value is 1 and the maximum is a 32-bit unsigned integer. The default is 1024.
XMLUDPPacketSize	Required when using identity caching. Indicates the maximum size of XML packets to be sent or received. The minimum value is 1 and the maximum is a 32-bit unsigned integer. The default is 4096.
RollingEncryptionKeyChangePeriod	Used in conjunction with the session-cache ResourceManager, this property specifies the length of time a given EncryptionKey will be used before a new one is created. When the session-cache ResourceManager caches User-Password attributes, Cisco Prime AR encrypts the User-Password so it is not stored in memory or persisted on disk in clear text. Cisco Prime AR uses up to 255 encryption keys, using a new one after each RollingEncryptionKeyChangePeriod expires. If RollingEncryptionKeyChangePeriod is set to <i>2 days</i> , Cisco Prime AR will create and begin using a new EncryptionKey every two days. The oldest key will be retired, and Cisco Prime AR will re-encrypt any User-Passwords that used the old key with the new key. This way, if the RollingEncryptionKeyChangePeriod is set to <i>1 day</i> , no key will be older than 255 days.

Table 4-43 *Advanced Object Properties (continued)*

Property	Description
SessionPurgeInterval	<p>Optional; the SessionPurgeInterval property determines the time interval at which to check for timed-out sessions. If no value is set, the session timeout feature is disabled. The checks are performed in the background when system resources are available, so checks might not always occur at the exact time set.</p> <p>The minimum recommended value for SessionPurgeInterval is 60 minutes. The SessionPurgeInterval value is comprised of a number and a units indicator, as in n units, where a unit is one of minutes, hours, days, or weeks.</p>
EapBadMessagePolicy	<p>Set to one of two values: SilentDiscard (the default) or RejectFailure.</p> <p>When set to SilentDiscard, the Cisco Prime AR server silently discards and ignores bad EAP messages unless the protocol specification explicitly requires a failure message.</p> <p>When set to RejectFailure, the Cisco Prime AR server sends RADIUS Access-Rejects messages with embedded EAP-Failure in response to bad EAP messages as described in Internet RFC 3579.</p>
StaleSessionTimeout	<p>Required; the default value is “1 hour.” Specifies the time interval to maintain a session when a client does not respond to Accounting-Stop notification.</p> <p>When the Cisco Prime AR server does not receive an Accounting-Response from a client after sending an Accounting-Stop packet, Cisco Prime AR maintains the session for the time interval configured in this property before releasing the session.</p> <p>This property is stored as a string composed of two parts: a number and a unit indicator (<n> <units>) similar to the MaxFileAge property where the unit is one of: M, Minute, Minutes, H, Hour, Hours, D, Day, Days, W, Week, or Weeks.</p>
Ports/	<p>Optional; allows you to use ports other than the default, 1645 and 1646. You can use this option to configure Cisco Prime AR to use other ports,. If you add additional ports, however, Cisco Prime AR will use the added ports and no longer use ports 1645 and 1646. These ports can still be used by adding them to the list of ports to use. For more information, see Ports, page 4-73.</p>
Interfaces	<p>Optional; see Interfaces, page 4-73</p>
ReplyMessages	<p>Optional; see Reply Messages, page 4-73.</p>
AttributeDictionary	<p>Optional; see Attribute Dictionary, page 4-75.</p>
SNMP	<p>Optional; see SNMP, page 4-76.</p>

Table 4-43 Advanced Object Properties (continued)

Property	Description
RFC Compliance/	<p>Optional; enables you to modify the Cisco Prime AR server to behave in a way that might deviate from RFC compliance in a special use case scenario.</p> <p>When AllowRejectAttrs is set to FALSE, Reply-Message attributes will not be passed in an Access Reject packet. When AllowRejectAttrs is set to TRUE, attributes will be allowed to pass in an Access Reject packet.</p> <p>When AllowEAPRejectAttrs is set to FALSE, Reply-Message attributes will not be passed in an Access Reject packet if the packet contains EAP-Message attribute. When AllowEAPRejectAttrs is set to TRUE, attributes will be allowed to pass in an Access Reject packet even if the packet contains EAP-Message attribute.</p> <p>Note Changing the state of either of these properties requires you to reload the Cisco Prime AR server.</p>
DDNS	This subdirectory holds the SynthesizeReverseZone property and a list of Transaction Signatures (TSIG) keys.
SynthesizeReverseZone	This property exists under DDNS and controls whether Cisco Prime AR automatically generates the name of the reverse zone (in-addr.arpa) that is updated with PTR records. If this attribute is enabled and the resource manager does not have an explicit ReverseZoneName property configured, the server uses the IP address and DNSHostBytes property to generate the reverse zone name. The default value is TRUE.
ODBCDataSources	A list of ODBC data sets and their associated environments including operating system, DBMS, and network platform used to access the DBMS an application wants to access. Required when using Oracle (or ODBC) accounting.
AttributeGroups	Includes a Default subdirectory with an Attributes subdirectory that contains commonly-used attributes for Change of Authorization (CoA) and Packet of Disconnect (POD). You can add new attributes to the default group or create a new group as necessary.
KeyStores	<p>Used to protect the security and integrity of the PACs it issues.</p> <ul style="list-style-type: none"> • NumberOfKeys—Number (from 1-1024) that specifies the maximum number of keys stored for EAP-FAST. • RolloverPeriod—Specifies the amount of time between key updates.

Table 4-43 Advanced Object Properties (continued)

Property	Description
NumberOfRemoteUDPServerSockets	<p>Required; the default value for this property is 4.</p> <p>The NumberOfRemoteUDPServerSockets property allows you to configure the number of source ports used while proxying requests to a remote radius server. If the NumberOfRemoteUDPServerSockets property is set to a value n, all remote servers share and use n sockets.</p> <p>The NumberOfRemoteUDPServerSockets value comprises a number, as in n, where n should be less than or equal to the current process file descriptor limit divided by 2.</p> <p> Note By default, the Radius process supports up to 1024 file descriptors. To increase the file descriptors, stop the arserver; in the arserver script, specify the required value to "NUMBER_OF_FILE_DESCRIPTORs" and restart the server. The value for "NUMBER_OF_FILE_DESCRIPTORs" should be in the range between 1024 to 65535.</p>
NumberofRadiusIdentifiersPerSocket	<p>This represents the number of RADIUS Identifiers that Cisco Prime AR can use per source port, while proxying requests to remote servers.</p> <p>To use a different source port for every request that is proxied, you need to set the value of this property to one.</p>
MaximumIncomingRequestRate	<p>Optional; the default value for this property is 0.</p> <p>The MaximumIncomingRequestRate property is used to limit the incoming traffic in terms of "allowed requests per second". Serves as a soft limit.</p> <p>The MaximumIncomingRequestRate property comprises a number n, where n can be any nonzero value.</p>

Table 4-43 Advanced Object Properties (continued)

Property	Description
HideSharedSecretAndPrivateKeys	<p>Required; the default value is TRUE.</p> <p>The HideSharedSecretAndPrivateKeys property hides:</p> <ul style="list-style-type: none"> • The secret that is shared between a Radius Client and a Radius Server or between two radius servers in a radius proxy scenario. • The PrivateKeyPassword under the certificate-based EAP services. <p>When this property is set to TRUE, the following properties are displayed as <encrypted>:</p> <ul style="list-style-type: none"> • PrivateKeyPasswords in: <ul style="list-style-type: none"> – peap-v0 service – peap-v1 service – eap-tls service – eap-ttls service – eap-fast service • SharedSecret in: <ul style="list-style-type: none"> – RemoteServers of type radius – RemoteServers of type map-gateway – Clients object – Resource Manager of type usr-vpn under Gateway subobject • PseudonymSecret in eap-sim service • DynamicAuthSecret under DynamicAuthorizationServer subject in Clients object • RepSecret under Replication • Secret in /radius/advanced/DDNS/TSIGKeys <p>When the value for this property is set to FALSE, all the above properties are displayed in clear text.</p>
MaximumOutstandingRequests	<p>Optional; the default value for this property is 0.</p> <p>The MaximumOutstandingRequests property is used to limit the incoming traffic in terms of “requests processed”. Serves as a hard limit.</p> <p>The MaximumOutstandingRequests property comprises a number <i>n</i>, where <i>n</i> can be any nonzero value.</p>
Diameter	Required; See Diameter, page 4-77

Table 4-43 Advanced Object Properties (continued)

Property	Description
TPSSamplingPeriodInSecs	This represents the sampling period in seconds. The minimum sampling period is set to 5. The default is 30.
LogTPSActivity	When set to true this property enables to log in the TPS usage in a CSV file. The TPS is logged in the following format: <code><mm-dd-yyyy>, <hh:mm:ss>, <tps-value></code> For example, 04-01-2012, 12:00:01, 102 The default is False.
TPSLogFilenamePrefix	This represents the prefix of the CSV file which will be available in the logs directory of Cisco Prime AR. The following represents the CSV filename format: <code><user-prefix>-<mm-dd-yyyy>.csv</code> tps-04-01-2012.csv
TPSLogFileCount	Configures the number of TPS Sampling log files to be maintained in the repository. The default value is 2.
AdditionalNativeOracleErrors	Optional; used to disconnect ODBC Remote Servers when configured native Oracle Error has occurred (which are not considered as connection errors). You must specify Native Errors as comma (,) separated integer values. For example, 04/14/2011 11:06:43.692: Log: ODBC client (DataSource 'CVOracleAcctDb', Connection 6): SQLExecute failed: SQLState:HY000 NativeError:12152 ErrorText:[Easysoft][Oracle]ORA-12152: TNS:unable to send break message 04/14/2011 10:44:59.388: Log: ODBC client (DataSource 'CVOracleAcctDb', Connection 3): SQLExecute failed: SQLState:HY000 NativeError:3114 ErrorText:[Easysoft][Oracle]ORA-03114: not connected to ORACLE For the above examples, the Native Errors need to be configured as follows: --> set AdditionalNativeOracleErrors 12152,3114 When any one of the Native Errors 12152 or 3114 occurs, Cisco Prime AR disconnects the ODBC Remote Server.

This section contains the following topics:

- [RemoteODBCSessionServer](#)
- [Using the RequireNASsBehindProxyBeInClientList Property](#)
- [Advance Duplicate Detection Feature](#)
- [Invalid EAP Packet Processing](#)
- [Ports](#)
- [Interfaces](#)
- [Reply Messages](#)
- [Attribute Dictionary](#)
- [SNMP](#)
- [Diameter](#)

RemoteODBCSessionServer

The following is an example of theRemoteODBCSessionServer configuration:

```
--> cd /Radius/Advanced/RemoteODBCSessionServer/

[ //localhost/Radius/Advanced/RemoteODBCSessionServer ]
  ReactivateTimerInterval = 300000
  Timeout = 15
  DataSourceConnections = 8
  ODBCDataSource =
  KeepAliveTimerInterval = 0
  BufferAccountingPackets = TRUE
  MaximumBufferFileSize = "10 Megabytes"
  CacheLimit = 250000
  UseCacheIndex = 0
```

Table 4-44 lists and defines the RemoteODBCSessionServer properties.

Table 4-44 RemoteODBCSessionServer Properties

Property	Description
ReactivateTimerInterval	Mandatory time interval (in milliseconds) to activate an inactive server; defaults to 300000 ms
Timeout	Mandatory time interval (in seconds) to wait for SQL operation to complete; defaults to 15 seconds
DataSourceConnections	Mandatory number of connections to be established; defaults to 8
ODBCDataSource	Name of the ODBCDataSource to use and must refer to one entry in the list of ODBC datasources configured under /Radius/Advanced/ODBCDataSources . Mandatory; no default
KeepAliveTimerInterval	Mandatory time interval (in milliseconds) to send a keepalive to keep the idle connection active; defaults to zero (0) meaning the option is disabled

Table 4-44 RemoteODBCSessionServer Properties (continued)

Property	Description
BufferAccountingPackets	<p>Mandatory, TRUE or FALSE, determines whether to buffer the accounting packets to local file, defaults to TRUE which means that packet buffering is enabled.</p> <p>Note When set to TRUE, a constant flow of incoming accounting packets can fill the buffer backing store files in <code>/cisco-ar/data/odbc</code> beyond the size configured in <code>MaximumBufferFileSize</code>. Configure <code>BackingStoreDiscThreshold</code> in Radius/Advanced when using ODBC accounting. See Advanced, page 4-58 for information about how to configure <code>BackingStoreDiscThreshold</code>.</p>
MaximumBufferFileSize	Mandatory if <code>BufferAccountingPackets</code> is set to TRUE, determines the maximum buffer file size, defaults to 10 Megabyte)
CacheLimit	Default is 250000; This represents the overall limit on cache of all 'remote' session managers. This value is interpreted as the maximum number of packets that can be present in cache. When the number of sessions hits this limit, sessions will be 'cached out'. This cache out operation will continue, until the cache is at least 20% free.
UseCacheIndex	<p>If set to 1, it enables a fast cache based lookup index for the items in the database. This optimizes the number of queries to the database hence will improve performance, but limits the number of sessions that can be scaled.</p> <p>If set to 0, it disables fast cache based lookup index.</p>

**Note**

Remote session manager will work only with Oracle database.

Using the RequireNASsBehindProxyBeInClientList Property

You can use the property **RequireNASsBehindProxyBeInClientList** to require NASs that send requests indirectly through a proxy to be listed in the Clients list or to allow the proxy to represent them all.

- When you want to ensure the proxy is only sending requests from NASs known to this server, set the property to TRUE, and list all of the NASs using this proxy. This increases memory usage.
- When it is impossible to know all of the NASs using this proxy or when you do not care, set the property to FALSE. Cisco Prime AR will use the proxy's IP address to identify the origin of the request.

Advance Duplicate Detection Feature

Cisco Prime AR automatically detects and handles duplicate requests it is currently working on. It also provides an optional, more complex mechanism to handle duplicate requests that can be received by the server after it has completed processing the original request. These duplicate requests can consume extra processing power, and, if received out of order (as RADIUS is a UDP-based protocol) might cause Session Management problems.

One solution is the Advanced Duplicate Detection feature which causes Cisco Prime AR to *remember* requests it has seen, as well as the response sent to that request, for a configurable amount of time.

To enable this feature, perform the following:

- Set the **UseAdvancedDuplicateDetection** property in the **/Radius/Advanced** section of the configuration to **TRUE**.
- Set the **AdvancedDuplicateDetectionMemoryInterval** in the **/Radius/Advanced** section to specify how long (in milliseconds) Cisco Prime AR should remember a request.



Note

Enabling this feature causes Cisco Prime AR to keep more of its preallocated packet buffers in use for a longer period of time. The number of preallocated buffers is controlled by the **MaximumNumberOfRadiusPackets** property in the **/Radius/Advanced** section of the configuration. This property might need to be increased (which will increase the amount of memory used by Cisco Prime AR) when the Advanced Duplicate Detection feature is enabled.

Invalid EAP Packet Processing

Cisco Prime AR has been enhanced to implement *fatal error* packet handling for Extensible Authentication Protocol (EAP) messages as described in section 2.2 of Internet RFC 3579 which states the following:

A RADIUS server determining that a fatal error has occurred must send an Access-Reject containing an EAP-Message attribute encapsulating EAP-Failure.

Because this enhancement is a deviation from various EAP specifications, you must explicitly enable this feature through a new configuration property in **/Radius/Advanced** named *EapBadMessagePolicy*.

You can set the *EapBadMessagePolicy* property to one of two values: *SilentDiscard* (the default) or *RejectFailure*. When set to *SilentDiscard*, the Cisco Prime AR server silently discards and ignores bad EAP messages unless the protocol specification explicitly requires a failure message. When set to *RejectFailure*, the Cisco Prime AR server sends RADIUS Access-Rejects messages with embedded EAP-Failure in response to bad EAP messages as described in Internet RFC 3579.

The implementation of EAP authentication methods in Cisco Prime AR behaves as described in Internet RFC 2284 (EAP) and related EAP method specifications. These specify *silent discard* as the standard way to handle all EAP error conditions. Any EAP response message from the client that contains an error or is received in an invalid authenticator state is discarded and there is no error response.

In a configuration where EAP requests are proxied between RADIUS servers using RADIUS messages (EAP over RADIUS), the silent discard of an EAP message means that no RADIUS response message is sent back to the originating RADIUS server. Because of this, the RADIUS server originating the request eventually declares the destination RADIUS server *dead* and fails over to a backup server (if so configured).

Ports

The Ports list specifies which ports to listen to for requests. When you specify a port, Cisco Prime AR makes no distinction between the port used to receive Access-Requests and the port used to receive Accounting-Requests. Either request can come in on either port.

Most NASs send Access-Requests to port 1645 and Accounting-Requests to 1646, however, Cisco Prime AR does not check.

When you do not specify any ports, Cisco Prime AR reads the `/etc/services` file for the ports to use for access and accounting requests. If none are defined, Cisco Prime AR uses the standard ports (1645 and 1646).

Interfaces

The Interfaces list specifies the interfaces on which the RADIUS server receives and sends requests. You specify an interface by its IP address.

- When you list an IP address, Cisco Prime AR uses that interface to send and receive Access-Requests.
- When no interfaces are listed, the server performs an interface discover and uses all interfaces of the server, physical and logical (virtual).



Note

The IP address format is enhanced to support both IPv4 and IPv6.

Reply Messages

The Reply Messages list allows you to choose the reply message based on the reason the request was rejected. Each of the following properties (except **Default**) corresponds to a reason why the packet was rejected. The Reply Message properties allows you to substitute your own text string for the defined errors. After you set the property (with the **set** command) and the reason occurs, Cisco Prime AR sends the NAS that message in the Access-Reject packet as a **Reply-Message** attribute.

You might want to substitute your own messages to prevent users from getting too much information about why their requests failed. For example, you might not want users to know the password was invalid to prevent hackers from accessing your system. In such a case, you might specify the text string “unauthorized access” for the property **UserPasswordInvalid**.

Table 4-45 lists the **Reply Message** properties.

Table 4-45 Reply Message Properties

Property	Description
Default	Optional; when you set this property, Cisco Prime AR sends this value when the property corresponding to the reject reason is not set.
UnknownUser	Optional; when you set this property, Cisco Prime AR sends back this value in the Reply-Message attribute whenever Cisco Prime AR cannot find the user specified by User-Name .

Table 4-45 Reply Message Properties (continued)

Property	Description
UserNotEnabled	Optional; when you set this property, Cisco Prime AR sends back this value in the Reply-Message attribute whenever the user account is disabled.
UserPasswordInvalid	Optional; when you set this property, Cisco Prime AR sends back this value in the Reply-Message attribute whenever the password in the Access-Request packet did not match the password in the database.
UnableToAcquireResource	Optional; when you set this property, Cisco Prime AR sends back this value in the Reply-Message attribute whenever one of the Resource Managers was unable to allocate the resource for this request.
ServiceUnavailable	Optional; when you set this property, Cisco Prime AR sends back this value in the Reply-Message attribute whenever a service the request needs (such as a RemoteServer) is unavailable.
InternalError	Optional; when you set this property, Cisco Prime AR sends back this value in the Reply-Message attribute whenever an internal error caused the request to be rejected.
MalformedRequest	Optional; when you set this property, Cisco Prime AR sends back this value in the Reply-Message attribute whenever a required attribute (such as User-Name) is missing from the request.
ConfigurationError	Optional; when you set this property, Cisco Prime AR sends back this value in the Reply-Message attribute whenever the request is rejected due to a configuration error. For example, if a script sets an environment variable to the name of an object such as Authentication-Service , and that object does not exist in the configuration, the reason reported is ConfigurationError.
IncomingScriptFailed	Optional; when you set this property, Cisco Prime AR sends back this value in the Reply-Message attribute whenever one of the IncomingScripts fails to execute.
OutgoingScriptFailed	Optional; when you set this property, Cisco Prime AR sends back this value in the Reply-Message attribute whenever one of the OutgoingScripts fails to execute.
IncomingScriptRejectedRequest	Optional; when you set this property, Cisco Prime AR sends back this value in the Reply-Message attribute whenever one of the IncomingScripts rejects the Access-Request.
OutgoingScriptRejectedRequest	Optional; when you set this property, Cisco Prime AR sends back this value in the Reply-Message attribute whenever one of the OutgoingScripts rejects the Access-Request.
TerminationAction	Optional; when you set this property, Cisco Prime AR sends back this value in the Reply-Message attribute whenever Cisco Prime AR processes the Access-Request as a Termination-Action and is being rejected as a safety precaution.

Attribute Dictionary

The Attribute dictionary allows you to specify the attributes to the RADIUS server. Cisco Prime AR comes with the standard RADIUS attributes (as defined by the RFC 2865) as well as the attributes required to support the major NASs. For more information about the standard attributes, see [Appendix C, “RADIUS Attributes.”](#)

All RADIUS requests and responses consist of one or more *attributes*, such as the user’s name, the user’s password, the type of service the NAS should provide to the user, or the IP address the user should use for the session.

In the request and response packets, an attribute is composed of a number (between 1-255) that specifies the type of attribute to use, a length that specifies the entire attribute length, and a value. How the value is interpreted depends on its type. When it is a username, the value is a string. When it is the NAS’s IP address, the value is an IP address, and so on.

[Table 4-46](#) lists the Attribute dictionary properties.

Table 4-46 *Attribute Dictionary Properties*

Property	Description
Name	Required; must be unique in the Attribute dictionary list within the same context. Although it should be an attribute defined in the RFC, the name can be any attribute defined by your client. The NAS typically comes with a list of attributes it uses. Attributes are referenced in the Profile and by Scripts by this name. The accounting file service also uses this name when printing the attribute.
Description	Optional description of the attribute.
Attribute	Required; must be a number between 1-255. It must be unique within the Attribute dictionary list.
Type	Required; must be set to one of the types listed in Table 4-47 . The type governs how the value is interpreted and printed.

Types

Types are required and must be one of the following listed in [Table 4-47](#).

Table 4-47 *Types Attributes*

Property	Description
UNDEFINED	Treated as a sting of binary bytes.
UINT32	Unsigned 32-bit integer.
STRING	Character string.
IPADDR	A valid IP address in dotted-decimal format.
CHAP_PASS WORD	17-byte value representing the password.

Table 4-47 *Types Attributes (continued)*

Property	Description
ENUM	Enums allow you to specify the mapping between the value and the strings. After you have established this mapping, Cisco Prime AR then replaces the number with the appropriate string. The min/max properties represent the lowest to highest values of the enumeration.
VENDOR_SPECIFIC	Vendor Specific Attribute (VSAs) are a special class of attribute. VSAs were created to extend the standard 256 attributes to include attributes required by specific manufacturers. VSAs add new capabilities for the value field in an attribute. Rather than being a simple integer string, or IP address, the value of a VSA can be one or more subattributes whose meaning depends on the vendor's definition. The Vendors list allows you to add, delete, or modify the definitions of the vendors and the subattributes they specify.

Vendor Attributes

Table 4-48 lists the **Vendor** properties.

Table 4-48 *Vendor Properties*

Property	Description
Name	Required; must be unique in the Vendors attribute list.
Description	Optional; description of the subattribute list.
VendorID	Required; must be a valid number and unique within the entire attribute dictionary.
Type	Required; must be one of the following: UNDEFINED, UINT32, STRING, IPADDR, CHAP_PASSWORD, ENUM, or SUB_ATTRIBUTES.

SNMP

Table 4-49 lists the five properties of the SNMP directory.

Table 4-49 *SNMP Properties*

Property	Description
Enabled	Either TRUE or FALSE; default is FALSE
TracingEnabled	Either TRUE or FALSE; default is FALSE
InputQueueHighThreshold	An integer; default is 90
InputQueueLowThreshold	An integer; default is 60
MasterAgentEnabled	Either TRUE or FALSE; default is TRUE

If Enabled and MasterAgentEnabled are both TRUE, **arservagt** will start and stop the SNMP daemon (**snmpd**). If either of these properties is FALSE, if the Cisco Prime AR server is not using SNMP or if your site uses a different master agent, **arservagt** will not start your master agent.

Diameter

This section explains how to configure Diameter general configuration and transport management.

Change the directory to **/Radius/Advanced/Diameter**.

```
//localhost/Radius/Advanced/Diameter
  General/
  TransportManagement/
```

The following configuration is used to configure Diameter general configuration like Product name and Version.

```
[ //localhost/Radius/Advanced/Diameter/General ]
  Product = Cisco Prime Access Registrar
  Version = 6.0
  AuthApplicationIdList = 1
  AcctApplicationIdList = 3
```

Table 4-50 describes the Diameter general properties.

Table 4-50 *Diameter General Properties*

Property	Description
Product	Optional; name of the product.
Version	Optional; version number.

Table 4-50 Diameter General Properties (continued)

Property	Description
AuthApplicationIdList	<p>Specifies the list of AuthApplications that the Cisco Prime AR server registers to Diameter Base stack during start up. It is a combination of Auth ApplicationId's separated by colon.</p> <p>For example:</p> <p>For Registering NASREQApplication,</p> <p style="padding-left: 40px;">--> set AuthApplicationIdList 1</p> <p>For Registering applications with id's 1 and 5,</p> <p style="padding-left: 40px;">--> set AuthApplicationIdList 1:5</p> <p>Note The Auth ApplicationIds that are configured should be present in /Radius/Advanced/Diameter/Applications section.</p>
AcctApplicationIdList	<p>Specifies the list of AcctApplications that the Cisco Prime AR server registers to Diameter Base stack during start up. It is a combination of Acct ApplicationId's separated by colon.</p> <p>For example:</p> <p>For Registering BaseAccountingApplication,</p> <p style="padding-left: 40px;">--> set AcctApplicationIdList 3</p> <p>Note The AcctApplicationId's that are configured should be present in /Radius/Advanced/Diameter/Applications section.</p>

Configuring Diameter TransportManagement Properties

The following example shows the Diameter transport management configuration:

```
[ //localhost/Radius/Advanced/Diameter/TransportManagement ]
Identity = toby-ar1.cisco.com
Realm = cisco.com
TCPListenPort = 3868
SCTPListenPort = 3868
EnableIPV6 = FALSE
WatchdogTimeout = 500
ReconnectInterval = 500
MaxReconnections = 3
RequestRetransmissionInterval = 100
MaxRequestRetransmissionCount = 3
ReceiveBufferSize = 2048
AdvertisedHostNames = toby-ar1.cisco.com
```

Table 4-51 describes the Diameter transport management properties.

Table 4-51 Diameter TransportManagement Properties

Property	Description
Identity	Required; identity of the system on which Diameter application is running. Must be set to a valid resolvable string.
Realm	Required; must be set to a valid Realm in the domain.
TCPListenPort	Required; port number on which Cisco Prime AR server listens for TCP peer connections.
SCTPListenPort	Required; port number on which Cisco Prime AR server listens for SCTP peer connections.
EnableIPv6	Required; if set to TRUE it enables IPV6 for the Diameter application.
WatchdogTimeout	Required; specifies the time interval between watch dog messages.
ReconnectInterval	Required; specifies the time interval between which Cisco Prime AR server attempts to connect to a disconnected peer. If set to 0, then no attempt will be made to connect to a disconnected peer.
MaxReconnections	Required; specifies the number of times Cisco Prime AR server tries to Make a reconnection attempt. If set to 0, then no attempt will be made to reconnect.
RequestRetransmissionInterval	Required; the time for which retransmission of pending requests will be done. If set to 0, then no attempt will be made to retransmit.
MaxRequestRetransmissionCount	Required, maximum number of times Cisco Prime ARserver tries to retransmit a pending request. If set to 0, then no attempt will be made to retransmit.
ReceiveBufferSize	Required; intial size of buffer that is preallocated for message reception.
AdvertisedHostNames	Optional; specifies the local hostname address that will be advertised by the Cisco Prime AR server to other peers during CER/CEA exchange. For example: AdvertisedHostNames = toby-ar1.cisco.com

Configuring Diameter SessionManagement

The following example shows the Diameter session management configuration:

```
//localhost/Radius/Advanced/Diameter/SessionManagement ]
  MaxSessions = 10000
  AuthSessions/
  AcctSessions/
  AuthSessions/
  EnableStatefulSessions = TRUE
  AuthSessionTimeout = 5
  LifeTimeTimeout = 360
  GracePeriodTimeout = 30
  AbortRetryTimeout = 20
  AcctSessions/
  AcctSessionTimeOut = 30
  InterimInterval = 5
  RealTime = 0
```

Table 4-52 describes the Diameter SessionManagement properties.

Table 4-52 Diameter SessionManagement Properties

Property	Description
MaxSessions	Required; specifies the maximum number of concurrent Diameter sessions Cisco Prime AR server will maintain. These sessions include both Auth and Acct sessions.
AuthSessions/EnableStatefulSessions	If set to TRUE, the server will enforce stateful sessions and the client will hint for stateful sessions. Default Value is TRUE. Set the property to FALSE to disable stateful sessions.
AuthSessionTimeout	Required; specifies the timeout in seconds before a session requires reauthentication.
LifeTimeTimeout	Required; specifies the timeout in seconds before a session is terminated regardless of whether the session has been reauthenticated.
GracePeriodTimeout	Required; specifies the grace period after the life timeout and before the full termination of the session.
AbortRetryTimeout	Required; specifies the timeout between the subsequent Abort Session Request (ASR) messages if the initial attempt fails.
AcctSessions/AcctSessionTimeOut	Required; specifies the the timeout in seconds before a session requires reauthentication.
InterimInterval	Required; specifies the interim interval dictated to the client if the entity is a server or hint to the server if the entity is a client.
RealTime	Required; RealTime value dictated to the client.

Configuring Diameter Application

Table 4-53 describes the Diameter Application properties.

Table 4-53 Diameter Application Properties

Property	Description
Name	Required; name of the application.
Description	Optional; description of the application.
IsVendorSpecific	Required; the default is FALSE. If set to FALSE, the application is ordinary application. If set to TRUE, the application is a VendorSpecific Application.
IsAuthApplication	Required; if set to TRUE the application represents AuthApplication else it represents Accounting Application.
Application ID	Required; specifies the unique integer value for the application. The following are examples of Diameter application: NASREQ 1 Mobile-IP 2 Diameter Base Accounting 3 Note ApplicationId property must be set to 0 for Base Protocol.
VendorSpecificApplicationID	Required; specifies the integer value for the vendor specific application.
VendorID	Required; specifies the VendorID for the application. Example: DIAMETER 3GPP Cx APPLICATION VendorSpecificApplicationID 16777216 VendorID 10415
ApplicationURI	Optional; specifies the URI of the Application. Eg: "ftp://ftp.ietf.org/internet-drafts/draft-ietf-aaa-diameter-nasreq-12.txt"
Commands	Required; an indexed list from 1 to <n>. Each entry in the list is the name of the command. It specifies the list of commands associated with the application.

Configuring the Diameter Application

To configure the Diameter application:

- Step 1** Move to `//localhost/Radius/Advanced/Diameter/Applications` directory:
- Step 2** Add the application you want to add (eg: NASREQ).

```
add NASREQ
```

```
Added NASREQ
```

cd NASREQ

```
[ //localhost/Radius/Advanced/Diameter/Applications/NASREQ ]
  Name = NASREQ
  Description =
  IsAuthApplication = TRUE
  IsVendorSpecific = FALSE
  ApplicationID =
  ApplicationURI =
  Commands/
```

Step 3 Set the ApplicationId and ApplicationURI .

set ApplicationId 1

```
Set ApplicationId 1
```

```
set ApplicationURL "ftp://ftp.ietf.org/internet-drafts/draft-ietf-aaa-diameter-nasreq-12.txt"
```

Step 4 Add the list of commands for this application.

cd commands/

```
Set 1 AA
```

Configuring Diameter Commands

Table 4-54 describes the Diameter Application properties.

Table 4-54 *Diameter Command Properties*

Property	Description
Name	Required; name of the command.
CommandCode	Required; specifies the integer code of the command.
EnableProxyBit	Required; default is TRUE . When enabled it represents the message is proxiabile.

Table 4-54 Diameter Command Properties (continued)

Property	Description
RequestMsgAVPs /	<p>The RequestMsgAVPs define the placement of AVPs within the request command. This contains three sub directories: Fixed, Required and Optional.</p> <p>Fixed - Defines the fixed position of AVP in a request message</p> <p>Required - The AVP must be present and can appear anywhere in the request message.</p> <p>Optional - The AVP name in optional cannot evaluate to any avp name which is included in a fixed or required directory. The avp can appear anywhere in the request message.</p> <p>For example:</p> <pre>cd Fixed/ Add Session-Id cd Session-Id/ Name = Session-Id Description = Min = 0 Max = 1</pre> <p>where:</p> <p>Min is the minimum number of times AVP element may be present in a request. The default value is 0.</p> <p>Max is the maximum number of times the element may present in a request. A value of zero implies AVP is not present in the request.</p>
AnswerMsgAVPs/	<p>The AnswerMsgAVPs define the placement of AVP's within the answer command. This contains three sub directories: Fixed, Required and Optional.</p> <p>Fixed - Defines the fixed position of AVP in the answer message.</p> <p>Required - The AVP must present and can appear anywhere in the answer message.</p> <p>Optional - The AVP name in optional cannot evaluate to any avp name which is included in a fixed or required directory. The avp can appear anywhere in the answer message.</p>

Configuring the Diameter Commands

To configure the Diameter commands:

Step 1 Change to `/Radius/Advanced/Diameter/Commands`.

Step 2 Add AA command.

```
add AA
```

```
[ //localhost/Radius/Advanced/Diameter/Commands ]
```

```
cd AA/
```

```
cd AA/
```

Step 3 Set the properties for AA command.

```
[ //localhost/Radius/Advanced/Diameter/Commands/AA ]
  Name = AA
  Description =
  CommandCode =
  EnableProxyBit = TRUE
  RequestMsgAVPs/
  AnswerMsgAVPs/
```

set CommandCode 265

```
Set CommandCode 265
```

set EnableProxyBit TRUE

```
Set EnableProxyBit TRUE
```

Step 4 Configure the RequestMsgAVP's for the command.

cd RequestMsgAVPs/

```
[ //localhost/Radius/Advanced/Diameter/Commands/AA/RequestMsgAVPs ]
  Fixed/
  Required/
  Optional/
```

Add Fixed AVP's for the request message.

Add Fixed AVP's

```
cd Fixed/
```

add Session-Id

```
Added Session-Id
```

cd Session-Id/

```
[ //localhost/Radius/Advanced/Diameter/Commands/AA/RequestMsgAVPs/Fixed/Session-Id ]
  Name = Session-Id
  Description =
  Min = 0
  Max =
```

Maximum and Minimum property specifies the multiplicity of the AVP Inside a request (or response). Similarly add the required and Optional AVP's.

Step 5 Configure AnswerMsgAVP's similar to step 3.

cd AnswerMsgAVPs/

```
[ //localhost/Radius/Advanced/Diameter/Commands/AA/AnswerMsgAVPs ]
  Fixed/
  Required/
  Optional/
```

The following shows an example of NASREQ application configuration:

```
[ //localhost/Radius/Advanced/Diameter/Applications/NASREQ ]
  Name = NASREQ
  Description =
  IsAuthApplication = TRUE
  IsVendorSpecific = FALSE
  ApplicationID = 1
  ApplicationURI =
  ftp://ftp.ietf.org/internet-drafts/draft-ietf-aaa-diameter-nasreq-12.txt
  Commands/
  1. AA
```

The following shows an example of the AA command configuration:

```
[ //localhost/Radius/Advanced/Diameter/Commands ]
  Entries 1 to 1 from 1 total entries
  Current filter: <all>

[ //localhost/Radius/Advanced/Diameter/Commands/AA ]
  Name = AA
  Description =
  CommandCode = 265
  EnableProxyBit = TRUE
  RequestMsgAVPs/
  Fixed/
  Entries 1 to 1 from 1 total entries
  Current filter: <all>

  Session-Id/
  Name = Session-Id
  Description =
  Min = 1
  Max = 1
  Required/
  Entries 1 to 7 from 7 total entries
  Current filter: <all>

  Auth-Application-Id/
  Name = Auth-Application-Id
  Description =
  Min = 1
  Max = 1
  Auth-Request-Type/
  Name = Auth-Request-Type
  Description =
  Min = 1
  Max = 1
  Destination-Realm/
  Name = Destination-Realm
  Description =
  Min = 1
  Max = 1
  Origin-Host/
  Name = Origin-Host
  Description =
  Min = 1
  Max = 1
  Origin-Realm/
  Name = Origin-Realm
  Description =
  Min = 1
  Max = 1
  User-Name/
  Name = User-Name
```

```

        Description =
        Min = 0
        Max = 1
    User-Password/
        Name = User-Password
        Description =
        Min = 0
        Max = 1
Optional/
    Entries 1 to 42 from 42 total entries
    Current filter: <all>

    ARAP-Password/
        Name = ARAP-Password
        Description =
        Min = 0
        Max = 1
    ARAP-Security/
        Name = ARAP-Security
        Description =
        Min = 0
        Max = 1
    ARAP-Security-Data/
        Name = ARAP-Security-Data
        Description =
        Min = 0
        Max = 100
    Auth-Grace-Period/
        Name = Auth-Grace-Period
        Description =
        Min = 0
        Max = 1
    Auth-Session-State/
        Name = Auth-Session-State
        Description =
        Min = 0
        Max = 1
    Authorization-Lifetime/
        Name = Authorization-Lifetime
        Description =
        Min = 0
        Max = 1
AnswerMsgAVPs/
    Fixed/
        Entries 1 to 1 from 1 total entries
        Current filter: <all>

        Session-Id/
            Name = Session-Id
            Description =
            Min = 1
            Max = 1
    Required/
        Entries 1 to 5 from 5 total entries
        Current filter: <all>

        Auth-Application-Id/
            Name = Auth-Application-Id
            Description =
            Min = 1
            Max = 1
        Auth-Request-Type/
            Name = Auth-Request-Type
            Description =

```



```
    Min = 1
    Max = 1
Origin-Host/
    Name = Origin-Host
    Description =
    Min = 1
    Max = 1
Origin-Realm/
    Name = Origin-Realm
    Description =
    Min = 1
    Max = 1
Result-Code/
    Name = Result-Code
    Description =
    Min = 1
    Max = 1
Optional/
    Entries 1 to 59 from 59 total entries
    Current filter: <all>

Acct-Interim-Interval/
    Name = Acct-Interim-Interval
    Description =
    Min = 0
    Max = 1
ARAP-Challenge-Response/
    Name = ARAP-Challenge-Response
    Description =
    Min = 0
    Max = 1
ARAP-Features/
    Name = ARAP-Features
    Description =
    Min = 0
    Max = 1
ARAP-Security/
    Name = ARAP-Security
    Description =
    Min = 0
    Max = 1
ARAP-Security-Data/
    Name = ARAP-Security-Data
    Description =
    Min = 0
    Max = 100
ARAP-Zone-Access/
    Name = ARAP-Zone-Access
    Description =
    Min = 0
    Max = 1
Auth-Grace-Period/
    Name = Auth-Grace-Period
    Description =
    Min = 0
    Max = 1
```

```

Auth-Session-State/
  Name = Auth-Session-State
  Description =
  Min = 0
  Max = 1
Authorization-Lifetime/
  Name = Authorization-Lifetime
  Description =
  Min = 0
  Max = 1

```

Configuring Diameter Dictionary

The Diameter dictionary contains a list of application specific AVPs.

[Table 4-55](#) describes the Diameter BaseProtocol AVP Properties.

Table 4-55 *Diameter BaseProtocol AVP Properties*

Property	Description
Name	Required; name of the application specific AVPs.
Description	Optional; description of the application specific AVPs.
IsVendorSpecific	Required; default is FALSE. If set to FALSE, the application is ordinary application and user is prompted to enter ApplicationID. If set to TRUE, the application is a VendorSpecific Application. User is prompted to enter VendorSpecificApplicationID and VendorID.
ApplicationID	Required; specifies the unique integer value for the application. Note The Application ID must be set to 0 for BaseProtocol AVPs.
VendorSpecificApplicationID	Required, Specifies the integer value for the vendor specific application.
VendorID	Required, specifies the VendorID for the application.
AVPS/	Specifies the list of application specific avps. Example: <pre>Accounting-Realtime-Required/ Name = Accounting-Realtime-Required Description = Attribute = 483 Mandatory = Must May-Encrypt = Yes Protected = MustNot Type = UINT32 Min = 0 Max = 253</pre> Refer Table 4-56 for the description of AVP properties.

Table 4-56 lists the application specific AVP properties.

Table 4-56 AVP Properties

Property	Description
Attribute	Specifies the integer value for the AVP.
Mandatory	Specifies whether the mandatory bit of this AVP should or should not be set.
May-Encrypt	If set to 'yes' then the AVP will be sent encrypted if the connection uses CMS security.
Protected	Specifies whether the protected bit of this AVP should or should not be set.
Type	Specifies the type of the Diameter AVP.

Configure the Diameter Dictionary

To configure the Diameter Dictionary:

Step 1 Change to **/Radius/Advanced/Diameter/Diameter Dictionary**.

Step 2 Add BaseProtocolAVPs.

```
add BaseProtocolAVPs
```

```
[ //localhost/Radius/Advanced/Diameter/Diameter Dictionary ]
```

```
cd BaseProtocolAVPs/
```

Step 3 Set the properties for BaseProtocolAVPs.

```
[ //localhost/Radius/Advanced/Diameter/Diameter Dictionary/BaseProtocolAVPs ]
Name = BaseProtocolAVPs
Description =
IsVendorSpecific = FALSE
ApplicationID = 0
AVPs/
```

```
set IsVendorSpecific "FALSE"
```

```
set IsVendorSpecific "FALSE"
```

```
set ApplicationID 0
```

```
set ApplicationID 0
```

Step 4 Configure the application specific AVPs.

```
cd AVPs/
```

```
add User-Name
```

Step 5 Configure User-Name AVP type and number**--> cd User-Name/**

```
[ //localhost/Radius/Advanced/Diameter/Diameter Dictionary/BaseProtocolAVPs/AVPs/User-Name
]
  Name = User-Name
  Description =
  Attribute = 1
  Mandatory = MustNot
  May-Encrypt = No
  Protected = MustNot
  Type = UTF8_STRING
  Min = 0
  Max = 253
```

set Attribute 1

```
set Attribute 1
```

set Type UTF8_STRING

```
set Type UTF8_STRING
```

The following is an example of Diameter BaseProtocol AVPs:

```
[ //localhost/Radius/Advanced/Diameter/Diameter Dictionary/BaseProtocolAVPs ]
  Name = BaseProtocolAVPs
  Description =
  IsVendorSpecific = FALSE
  ApplicationID = 0
  AVPs/
    Entries 1 to 55 from 55 total entries
    Current filter: <all>

    Accounting-Realtime-Required/
      Name = Accounting-Realtime-Required
      Description =
      Attribute = 483
      Mandatory = Must
      May-Encrypt = Yes
      Protected = MustNot
      Type = UINT32
      Min = 0
      Max = 253

    Accounting-Record-Number/
      Name = Accounting-Record-Number
      Description =
      Attribute = 485
      Mandatory = Must
      May-Encrypt = Yes
      Protected = MustNot
      Type = UINT32
      Min = 0
      Max = 253

    Accounting-Record-Type/
      Name = Accounting-Record-Type
      Description =
      Attribute = 480
      Mandatory = Must
      May-Encrypt = Yes
      Protected = MustNot
      Type = ENUM
```

```
Min = 0
Max = 253
Enums/
  1 = "Event Record"
  2 = "Start Record"
  3 = "Interim Record"
  4 = "Stop Record"
Accounting-Session-Id/
  Name = Accounting-Session-Id
  Description =
  Attribute = 44
  Mandatory = Must
  May-Encrypt = Yes
  Protected = May
  Type = STRING
  Min = 0
  Max = 253
Accounting-Sub-Session-Id/
  Name = Accounting-Sub-Session-Id
  Description =
  Attribute = 287
  Mandatory = Must
  May-Encrypt = Yes
  Protected = May
  Type = UINT64
  Min = 0
  Max = 253
```



CHAPTER 5

Using the radclient Command

This chapter describes how to use **radclient**, a RADIUS server test tool you run from the command line to test your Cisco Prime AR RADIUS server. You can use **radclient** to create packets, send them to a specific server, and examine the response.

Because the **radclient** command is Tcl-based, you can use it interactively or you can execute it as a Tcl script file.

To run the **radclient** command, enter:

```
radclient
```

After you enter the **radclient** command, you must log in to the RADIUS server and provide an administrator's username, such as admin, and the administrator's password.

This chapter contains the following sections:

- [radclient Command Syntax](#)
- [Working with Packets](#)
- [Attributes](#)
- [Using radclient Test Commands](#)

radclient Command Syntax

The **radclient** command syntax is:

```
radclient [-C <clustername>] [-N <adminname>] [-P <adminpassword>] [-i] [-n]  
[-p <load_path>] [-v] [-z debug_flags] [-I flag]
```

Valid flags are:

- **-C** <clustername>
- **-N** <adminname>
- **-P** <adminpassword>
- **-i**—Forces interactive mode
- **-n**—Skips loading **radclient.tcl**
- **-p** <path>—Specifies the load_path
- **-s**—Uses default cluster, admin user, and password

If you delete the admin user or modify the admin user's password, this option will no longer work.

- **-S <file>**—Sources specified file
- **-v**—Prints version and exits
- **-I <0 or 1>**—Enables to set as IPv4 or IPv6 client. *0* specifies IPv4 client and *1* specifies IPv6 client
- **-z debug_flags**—Specify debug levels. Debug flags must be of the format *X=n*, where *X* is the letter corresponding to the type of debug information you want to see, and *n* is the value. The higher the value, the more output. *X* can also be a string or a range of letters.

For example, the following command line sets the debug levels for A, B, and C to 3:

```
radclient -z ABC=3
```

The following example command line sets the debug levels for everything between A and Z inclusive and 1 to 5:

```
radclient -z A-Zl=5
```

Working with Packets

Using the **radclient** command, you can create packets (default or specific packets), view packets, send packets, read the value of packets, and delete packets.

This section contains the following topics:

- [Creating Packets](#)
- [Creating CHAP Access-Request Packets](#)
- [Viewing Packets](#)
- [Sending Packets](#)
- [Creating Empty Packets](#)
- [Setting Packet Fields](#)
- [Reading Packet Fields](#)
- [Deleting Packets](#)

Creating Packets

To create a basic RADIUS Access-Request packet, use the **radclient** command **simple**. This function creates a packet and fills in basic attributes. The syntax of the **simple** command is:

```
simple <user_name> <user_password>
```

For example, to create an Access-Request packet for user **bob** whose password is **bigDog**, enter:

```
simple bob bigDog
```

```
p001
```

The **radclient** command responds with `p001`, which is the identifier (name) of the newly created packet.

Creating CHAP Access-Request Packets

To create a CHAP Access-Request packet, use the **radclient** command **simple_chap**. The syntax of the **simple_chap** command is:

```
simple_chap <user_name> <user_password> <use_challenge>
```

<use_challenge> is a boolean that indicates whether to use the **CHAP-Challenge** attribute.

For example, to create a CHAP packet and use a *<use_challenge>*, enter:

```
simple_chap bob bigDog 1
```

```
p002
```

Viewing Packets

To view a packet or any other object, enter the object identifier at the **radclient** prompt. For example, to display packet `p001`, enter:

```
p001
```

```
Packet: code=Access-Request,id=0,length=0, attributes =  
User-Name = bob  
User-Password = bigDog  
NAS-Identifier = localhost  
NAS-Port = 0
```

Sending Packets

To send a packet, specify the packet identifier and enter the word **send**.

```
p001 send
```

You can optionally specify the host and port to which to send the packet. The default host is **localhost**, and the default port is **1645**.

When you want to send a packet to a different host and different port, you must specify them on the command line. For example, to send a packet to the RADIUS server `amazon`, at port number `1812`, enter:

```
p001 send amazon 1812
```

```
p002
```

When Cisco Prime AR receives a response to the packet you sent, it prints the response packet's object identifier before the **radclient** prompt returns.

The TCL variable *tries* determines how many times **radclient** retries to send the packet.

Creating Empty Packets

You can use **radclient** to create empty packets, then modify the packets to contain the appropriate fields. To create an empty packet, the syntax is:

```
packet <packet-type>
```

The optional *<packet-type>* argument can be the numerical RADIUS packet type identifier, such as 2, or the string representation, such as `Access-Accept`:

```
packet 2
```

```
p00d
```

```
p00d
```

```
Packet: code = Access-Accept, id = 0, length = 0, attributes =
```

Setting Packet Fields

You can modify the value of a packet field using the following syntax:

```
<packet-identifier> set <field> <value>
```

<packet-identifier> is the packet number, such as `p001`.

<field> is the packet field you want to modify and can be one of the following:

- `attrib`—Set attributes in the packet; *<value>* is the attribute identifier.
- `code`—The packet type (such as `Access-Request`); *<value>* is either a numeric packet-type or the string representation (for example, 1 or `Access Request`).
- `identifier`—Set the packet ID; *<value>* is the numeric ID.
- `length`—Set the packet length; *<value>* is the numeric length.
- `requestAuthenticator`—Set the request authenticator; *<value>* is a hex string with a colon separating each byte.

<value> is either a numeric packet-type, the string representation, or the hex string with a colon separating each byte.

For example, to set the identifier field to 99, enter:

```
p001 set identifier 99
```

```
99
```

```
p001
```

```
Packet: code = Access-Request, id = 99, length = 0, attributes =
  User-Name = bob
  User-Password = bigDog
  NAS-Identifier = localhost
  NAS-Port = 0
```

Reading Packet Fields

You can read (**get**) the value of any of the packet fields by using the syntax:

```
<packet-identifier> get <attrib>
```

For example, to **get** the **identifier** field, enter:

```
p001 get identifier
```

99

Deleting Packets

When you are writing long-running or iterating scripts, you might want to conserve memory by deleting packets when you are finished with them.

To delete a packet, enter:

```
<packet-identifier> delete
```

To delete all resources referred to by the packet `p001`, enter:

```
p001 delete
```

Attributes

Using the **radclient** command you can create specific RFC-defined attributes of requests and responses.

This section contains the following topics:

- [Creating Attributes](#)
- [Setting Multivalued Attributes](#)
- [Viewing Attributes](#)
- [Getting Attribute Information](#)
- [Deleting Attributes](#)
- [Using the radclient Command](#)

Creating Attributes

To create an attribute object, the syntax is:

```
<attrib> name <value>
```

<attrib> is a recognized RADIUS attribute name. <value> is the value of the attribute.

For example, to create the attribute **User-Name** and set its value to `bob`, enter:

```
attrib User-Name bob
```

a001

**Note**

a001 is the object identifier for the newly created attribute.

Setting Multivalued Attributes

Cisco Prime AR supports setting multivalued attributes (MVAs) in **radclient**. Use the set **mattrib** command to set multivalued attributes, as shown in the following example:

```
simple bob bob
```

```
p001
```

```
attrib cisco-avpair blah
```

```
a005
```

```
attrib cisco-avpair boo
```

```
a006
```

```
p001 set mattrib a005
```

```
p001
```

```
Packet: code = Access-Request, id = 0, length = 0, attributes =
User-Name = bob
User-Password = bob
NAS-Identifier = localhost
NAS-Port = 1
Cisco-AVPair = blah
```

```
p001 set mattrib a006
```

```
p001
```

```
Packet: code = Access-Request, id = 0, length = 0, attributes =
User-Name = bob
User-Password = bob
NAS-Identifier = localhost
NAS-Port = 1
Cisco-AVPair = blah
Cisco-AVPair = boo
```

Viewing Attributes

To view an attribute, or any other object, type the object identifier at the **radclient** prompt. For example, to display attribute **a001** created in the example above, enter:

```
a001
```

```
User-Name = bob
```

Getting Attribute Information

You can get the name and value of an attribute in various formats:

- `get name`—gets the name as a string
- `get value`—gets the value as a string
- `get type`—gets the name as an integer
- `get valueAsInt`—gets the value as an integer
- `get valueAsIPAddress`—gets the value as an IP address.

The following examples show how to get an attribute's name, type, value, and value as integer:

```
a001 get name
```

```
User-Name
```

```
a001 get type
```

```
1
```

```
a001 get value
```

```
bob
```

```
a001 get valueAsInt
```

```
a001: the value is not an int
```

Deleting Attributes

When you are writing long running or iterating scripts, you might want to conserve memory by deleting attributes when you are finished with them (be sure not to delete attributes being referred to by other objects, like packets.)

To delete all resources referred to by the attribute `a001`, enter:

```
a001 delete
```

Using the radclient Command

The following three examples show how to use **radclient** to create, send, and modify packets.

Example 1

This example creates an Access-Request packet for user `jane` with password `jane`, and sends it to the default RADIUS server (**localhost**).

```
simple jane jane
```

```
p001
```

The command **simple jane jane** creates the packet; the packet object identifier is **p001**. When you enter the packet object identifier, **radclient** displays the contents of the packet.

```
p001
```

```
Packet: code = Access-Request, id = 0, length = 0, attributes =
  User-Name = jane
  User-Password = jane
  NAS-Identifier = localhost
  NAS-Port = 0
```

When you enter the packet identifier and the command **send**, **radclient** sends the packet to the RADIUS server and prints the response packet object identifier.

```
p001 send
```

```
p002
```

When you enter the packet object identifier of the response, **radclient** displays the contents of the response packet.

```
p002
```

```
Packet: code = Access-Accept, id = 1, length = 38, attributes =
  Login-IP-Host = 204.253.96.3
  Login-Service = Telnet
  Login-TCP-Port = 541
```

Example 2

The following example creates a simple Access-Request packet, then adds other attributes to it.

```
simple jane jane
```

```
p003
```

The command line above shows creation of the packet **p003** using user-ID **jane** and password **jane**.

```
attrib Service-Type Framed
```

```
a00c
```

The line above shows creating the **Service-Type** attribute (with the object identifier **a00c**).

```
a00c
```

```
Service-Type = Framed
```

Entering the attribute object identifier **a00c** displays the attribute object.

```
p003 set attrib a00c
```

The line above adds the newly set attribute to the packet. The following line creates another attribute.

```
attrib NAS-Port 99
```

```
a00d
```

a00d

```
NAS-Port = 99
```

p003 set attrib a00d

The same steps add the **NAS-Port** attribute to the packet, and finally, the packet contents are displayed.

p003

```
Packet: code = Access-Request, id = 0, length = 0, attributes =  
User-Name = jane  
User-Password = jane  
NAS-Identifier = localhost  
Service-Type = Framed  
NAS-Port = 99
```

Example 3

Example 3 performs the same tasks as [Example 2](#) using the command substitution feature of Tcl which allows you to use the results of one command as an argument to another command. Square brackets invoke command substitution. The statement inside the brackets is evaluated, and the result is used in place of the bracketed command.

simple jane jane

```
p004
```

p004 set attrib [attrib Service-Type Framed]

p004 set attrib [attrib NAS-Port 99]

p004

```
Packet: code = Access-Request, id = 0, length = 0, attributes =  
User-Name = jane  
User-Password = jane  
NAS-Identifier = localhost  
Service-Type = Framed  
NAS-Port = 99
```

Using radclient Test Commands

You can use the **radclient** commands **timetest** and **callsPerSecond** to test the RADIUS server.

This section contains the following topics:

- [radclient Variables](#)
- [Using timetest](#)
- [Using callsPerSecond](#)
- [Additional radclient Variables](#)

radclient Variables

You control how **timetest** and **callsPerSecond** work using **radclient** variables. To set a **radclient** variable, use the **set** command as follows:

```
set variable value
```

[Table 5-1](#) lists the **radclient** variables used in **timetest** and **callsPerSecond** and their description.

Table 5-1 radclient Variables

Variable	Description
host	Destination host to send the packets (default is localhost)
num_packets	Number of packets to send at once (default is 256)
num_users	Modulus for the username pattern (default is 10000)
port	Port where radclient sends access-request packets (default is 1645). Changing this port does not affect the <code>accounting_port</code> .
retry_timeout	Length of time to wait after a timeout occurs before retrying
secret	Shared secret configured on the RADIUS server for the client (default is secret)
timeout	Length of time to wait before a timeout occurs
tries	Number of times to attempt to send
UserNamePattern	Pattern of the usernames (default is user%d%%PPP)
UserPasswordPattern	Pattern of the user passwords (default is user%d)

Using timetest

The **timetest** command sends a number of requests to the RADIUS server then waits for a response. When a response arrives, **timetest** immediately sends another request. **timetest** can keep up to 256 requests outstanding all the time.

The syntax of the **timetest** command is:

```
timetest <testtype> [<cycles> [<repetitions> [<starting user number> [<increment user number>]]]]
```

[Table 5-2](#) lists the applicable test types.

Table 5-2 Test Types

Test Type	Description
1	Access-Request
2	Access-Request + Accounting-Start + Accounting-Stop
3	Accounting-Start + Accounting-Stop
4	Ascend-IPA-Allocate + Ascend-IPA-Release
5	Access-Request + Ascend-IPA-Allocate + Ascend-IPA-Release
6	Access-Request + Ascend-IPA-Allocate + Accounting-Start + Ascend-IPA-Release + Accounting-Stop
7	Access-Request + USR-Resource-Free-Request
8	LEAP Identity + LEAP-Challenge Response + LEAP Challenge
9	LEAP Identity + LEAP-Challenge Response + LEAP Challenge + Accounting-Start + Accounting-Stop
10	Access-Request + Accounting-Start + Accounting-Stop with Home-Agent request
11	Access-Request + Accounting-Start + Accounting-Stop with ODAP request

Consider this **timetest** example with **radclient** variables set to the following:

```

host—1.1.1.2
port—1812
secret—cisco
UserNamePattern—user%d
UserPasswordPattern—puser%d
num_users—100,000
num_packets—128

```

In this example, **timetest** sends packets directly to the host at IP address 1.1.1.2 on port 1812 with a shared secret `cisco`. There are 100,000 users in the server's user database with the name pattern `user#` and password pattern `puser#`, where `#` ranges from 0-99,999, inclusive. The number of outstanding requests are limited to 128.

Before starting the timing test, **timetest** sends an Accounting-On packet to the AAA Server and waits for a response to make sure that any session management being performed on the AAA Server is reset before running the test. After a response is received, the **timetest** can begin.

Using callsPerSecond

The **callsPerSecond** command is a smart throttle that sends packets at a rate you set. If you set **callsPerSecond** to two transactions per second (TPS), **callsPerSecond** sends a packet every 0.5 seconds.

The syntax of the **callsPerSecond** command is:

```

callsPerSecond <callsPerSecond> <testtype> [<cycles> [<repetitions> [<starting user number>
[<increment user number>]]]]

```

Additional radclient Variables

Table 5-3 lists additional **radclient** variables and their description.

Table 5-3 Additional radclient Variables

Variable	Description
accounting_port	Port where the RADIUS server sends accounting packets (default is 1646). Note Changing accounting_port value does not affect the authentication port.
host	Name of host where Cisco Prime AR is installed
ignore_signature_errs	Causes server to ignore signature in the response
load_path	Search path to load source files with user processes
NASIdentifier	Value to set NAS-Identifier attribute
NASIPAddress	Value to set NAS-IP-Address attribute
NASPort	Value to set NAS-Port attribute
num_packets	Number of packets to send at once (default is 256)
num_users	Modulus for the username pattern (default is 10000)
port	Port where radclient sends access-request packets (default is 1645). Changing this port does not affect the accounting_port.
retry_timeout	Length of time to wait before attempting a retry
secret	Shared secret configured on the RADIUS server for the client (default is secret)
tclDefaultLibrary	Tclsh default library
tcl_patchLevel	Tclsh version with patch level
tcl_pkgPath	Tclsh install path
tcl_traceExec	Tclsh boolean to activate tracing
tcl_platform	Tclsh platform array
tcl_version	Tclsh version
tries	Number of retry attempts
UserNamePattern	Pattern of the usernames (default is user%d%%PPP)
UserPasswordPattern	Pattern of the user passwords (default is user%d)
verbose	Verbose flag for Tclsh



CHAPTER 6

Configuring Local Authentication and Authorization

Cisco Prime Access Registrar (Cisco Prime AR) allows user information to be stored in its own internal database or external stores such as an LDAP directory or Oracle database. This chapter describes how to configure Cisco Prime AR to perform authentication and authorization using the Cisco Prime AR internal database and how to verify and troubleshoot a local service and userlist configuration.

In RADIUS, an Access Request packet is a request for authentication and authorization(AA). Authentication checks username and password credentials, while authorization typically involves returning the correct information to allow the service a user is authorized to have. Cisco Prime AR performs AA and returns the appropriate RADIUS attributes in an Access Accept packet.

This chapter contains the following sections:

- [Configuring a Local Service and UserList](#)
- [Troubleshooting the Local Service and UserList Configuration](#)
- [aregcmd Command Performance](#)
- [UserDefined1 Property](#)
- [Access-Request Logging](#)

Configuring a Local Service and UserList

Cisco Prime AR uses services configured under **/Radius/Services** to process RADIUS requests. To process RADIUS access requests locally, you must configure a service and set its type to **local**. A local service references an Cisco Prime AR userlist.

The following sections show the commands you enter and the expected responses from the Cisco Prime AR server to do the following:

- [Configuring a Local Service](#)
- [Configuring a Userlist](#)
- [Configuring Cisco Prime Access Registrar to Use the Local Service For AA](#)
- [Activating the Configuration](#)

Throughout this chapter, the **aregcmd** commands you enter are shown in **bold** font, and the server responses are shown in smaller plain font as shown in the following:

command you enter

server response

Configuring a Local Service

Cisco Prime AR maintains **Services** under **/Radius**.

To configure a local service:

Step 1 Use the **add** command at **/Radius/Services** to create a Service.

cd /Radius/Services

[//localhost/Radius/Services]

add SouthBay

Added SouthBay

Step 2 Change directory to the new service and set its type to local.

cd SouthBay

[//localhost/Radius/Services/SouthBay]

set type local

Set Type local

Step 3 Use the **set** command to associate a userlist with the service.

set userlist SouthUsers

Set UserList SouthUsers

Configuring a Userlist

Cisco Prime AR maintains **UserLists** under **/Radius**.

To configure a userlist:

-
- Step 1** Use the **add** command at **/Radius/UserLists** to create a userlist.

```
cd /Radius/UserLists  
  
[ //localhost/Radius/UserLists ]
```

```
add SouthUsers  
  
Added SouthUsers
```

- Step 2** Change directory to the userlist and add users.

```
cd SouthUsers  
  
[ //localhost/Radius/UserLists/SouthUsers ]
```

```
add user1  
  
Added user1
```

- Step 3** Change directory to each user you add and set the user's password.

```
cd user1  
  
[ //localhost/Radius/UserLists/SouthUsers/user1 ]
```

```
set Password test  
  
Retype password to confirm:  
  
Set Password <encrypted>
```

Configuring Cisco Prime Access Registrar to Use the Local Service For AA

To configure Cisco Prime AR to use the local service for authentication and authorization, enter commands to set the **DefaultAuthenticationService** and **DefaultAuthenticationService** to the service you created, as shown in the following:

```
cd /Radius  
  
[ //localhost/Radius ]
```

```
set DefaultAuthenticationService SouthBay
```

```
Set DefaultAuthenticationService SouthBay
```

```
set DefaultAuthorizationService SouthBay
```

```
Set DefaultAuthorizationService SouthBay
```

Activating the Configuration

To activate the configuration changes you have made, enter the **save** command:

```
save
```

```
Validating //localhost...
```

```
Saving //localhost...
```

After you issue the **save** command, Cisco Prime AR attempts to validate the configuration, checks for all required properties, and ensures there are no logic errors. If the validation is successful, Cisco Prime AR saves the configuration to the MCD database.

Troubleshooting the Local Service and UserList Configuration

Before you begin troubleshooting, ensure that the current configuration is valid and active. To ensure that any configuration changes you have made are valid and stored in the database, you must issue the **save** command.

```
save
```

```
Validating //localhost...
```

```
Saving //localhost...
```

To ensure that the current configuration is active, issue the **reload** command.

```
reload
```

```
Reloading Server 'Radius'...
```

```
Server 'Radius' is Running, its health is 10 out of 10
```

Verifying the Configuration

To verify the configuration changes you have made:

Step 1 Check to see that the UserList exists under the service.

```
Is /Radius/Services/SouthBay
```

```
[ /Radius/Services/SouthBay ]
  Name = SouthBay
  Description =
  Type = local
  IncomingScript~ =
  OutgoingScript~ =
  OutagePolicy~ = RejectAll
  OutageScript~ =
  UserList = SouthUsers
```

Step 2 Check to see that user **user1** exists under the SouthUsers userlist.

ls /Radius/UserLists/SouthUsers

```
[ /Radius/UserLists/SouthUsers ]
  Entries 1 to 1 from 1 total entries
  Current filter: <all>
  Name = SouthUsers
  Description =
  user1/
```

Step 3 Turn on debugging.

trace /r 5

```
Traced "/Radius: Trace level is set to 5"
```

Step 4 Use **radclient** to send an Access-Request for user **user1**.

simple user1 test

The debugging output will be sent to the file **name_radius_1_log** in the **/opt/CSCOAr/logs** directory. The following example shows items you should expect in a successful Access-Request.



Note Lines of interest are in **bold font**.

```
11/12/2012 18:34:35: P1144: Packet received from 127.0.0.1
11/12/2012 18:34:35: P1144: Trace of Access-Request packet
11/12/2012 18:34:35: P1144:   identifier = 4
11/12/2012 18:34:35: P1144:   length = 62
11/12/2012 18:34:35: P1144:   reqauth = f5:37:f7:04:99:85:c7:63:8f:bc:f4:44:ab:03:4e:1a
11/12/2012 18:34:35: P1144:   User-Name = user1
11/12/2012 18:34:35: P1144:   User-Password = 59:fb:2e:a9:34:de:0e:15:60:8d:4b:64:77:6a:57:d8
11/12/2012 18:34:35: P1144:   NAS-Port = 2
11/12/2012 18:34:35: P1144:   NAS-Identifier = localhost
11/12/2012 18:34:35: P1144: Using Client: localhost (127.0.0.1)
11/12/2012 18:34:35: P1144: Using NAS: localhost (127.0.0.1)
11/12/2012 18:34:35: P1144: Request is directly from a NAS: TRUE
11/12/2012 18:34:35: P1144: Authenticating and Authorizing with Service SouthBay
11/12/2012 18:34:35: P1144: Getting User user1's UserRecord from UserList SouthUsers
11/12/2012 18:34:35: P1144: User user1's password matches
11/12/2012 18:34:35: P1144: No default Remote Session Service defined.
11/12/2012 18:34:35: P1144: Trace of Access-Accept packet
11/12/2012 18:34:35: P1144:   identifier = 4
11/12/2012 18:34:35: P1144:   length = 20
11/12/2012 18:34:35: P1144:   reqauth = 36:88:34:0c:cc:ea:9e:d8:6d:f5:14:f7:ab:26:e7:f6
11/12/2012 18:34:35: P1144: Sending response to 127.0.0.1
11/12/2012 18:34:35: Log: Request from localhost (127.0.0.1): User user1 accepted
```

The following example shows a trace for an unsuccessful Access-Request due to an invalid password.



Note Lines of interest are in **bold font**.

```
11/12/2012 19:05:13: P1527: Packet received from 127.0.0.1
11/12/2012 19:05:13: P1527: Trace of Access-Request packet
11/12/2012 19:05:13: P1527:11/12/2012 19:05:13: P1527:11/12/2012 19:05:13: P1527:
11/12/2012 19:05:13: P1527:11/12/2012 19:05:13: P1527:
11/12/2012 19:05:13: P1527:11/12/2012 19:05:13: P1527:11/12/2012 19:05:13: P1527: Using Client: localhost
(127.0.0.1)
11/12/2012 19:05:13: P1527: Using NAS: localhost (127.0.0.1)
11/12/2012 19:05:13: P1527: Request is directly from a NAS: TRUE
11/12/2012 19:05:13: P1527: Authenticating and Authorizing with Service SouthBay
11/12/2012 19:05:13: P1527: Getting User user1's UserRecord from UserList SouthUsers
11/12/2012 19:05:13: P1527: User user1's password does not match
11/12/2012 19:05:13: P1527: Rejecting request
11/12/2012 19:05:13: P1527: Rejecting request
11/12/2012 19:05:13: P1527: Trace of Access-Reject packet
11/12/2012 19:05:13: P1527:11/12/2012 19:05:13: P1527:11/12/2012 19:05:13: P1527:
11/12/2012 19:05:13: P1527:11/12/2012 19:05:13: P1527: Sending response to 127.0.0.1
11/12/2012 19:05:13: Log: Request from localhost (127.0.0.1): User user1 rejected (UserPasswordInvalid)
```

If a user's password is invalid, reset the password to ensure it was entered correctly. Also check that the shared secret being used by the RADIUS client and the Cisco Prime AR server match.

Configuring Return Attributes and Check-Items

Cisco Prime AR supports RADIUS check item attributes at the user and group levels. You can configure Cisco Prime AR to check for attributes that must be present or attributes that must not be present in the Access-Request packet for successful authentication. For a complete list of attributes supported in Cisco Prime AR, see [Appendix C, "RADIUS Attributes"](#).

When using check item attributes, Cisco Prime AR rejects Access-Requests if either of the following conditions exist:

- Any configured check item attributes are not present in the Access-Request packet
- Any Access-Request packet's check item attribute values do not match with those configured check item attribute values

This section contains the following topics:

- [Configuring Per User Return Attributes](#)
- [Configuring Per User Check-Items](#)
- [Verifying the Per User Return Attributes and Check-Items Configuration](#)
- [Configuring Return Attributes and Check-Items Using UserGroup](#)

Configuring Per User Return Attributes

User return attributes are attributes that are specific for a given user each time they log in. To configure a user's return attributes, change directory to the user's Attributes subdirectory and configure the desired attributes.

```
cd /Radius/UserLists/SouthUsers/User1/Attributes
```



```
[ //localhost/Radius/UserLists/SouthUsers/user1/Attributes ]
```

set Session-Timeout 60

```
Set Session-Timeout 60
```

set Callback-Number 5551124

```
Set Callback-Number 5551124
```

Configuring Per User Check-Items

Check Items are a way to check that certain attribute/values exist in a user's access-request. If the attribute/values are not present in the access-request, the Cisco Prime AR server rejects the access-request.

To check that an access-request for `user1` has the `Calling-Station-Id` attribute set to `5555678`, enter the following:

cd /Radius/UserLists/SouthUsers/User1/CheckItems

```
[ //localhost/Radius/UserLists/SouthUsers/user1/CheckItems ]
```

set Calling-Station-Id 5555678

```
Set Calling-Station-Id 5555678
```

Be sure to **save** your configuration to preserve your changes.

Verifying the Per User Return Attributes and Check-Items Configuration

A successful request will produce a trace similar to the following:

```
11/12/2012 14:08:07: P1539: Packet received from 127.0.0.1
11/12/2012 14:08:07: P1539: Trace of Access-Request packet
11/12/2012 14:08:07: P1539:   identifier = 1
11/12/2012 14:08:07: P1539:   length = 71
11/12/2012 14:08:07: P1539:   reqauth = d6:86:c5:1e:0e:a0:20:4f:9a:1a:2c:35:27:16:12:36
11/12/2012 14:08:07: P1539:   User-Name = user1
11/12/2012 14:08:07: P1539:   User-Password = 99:dc:4a:22:ef:f6:8b:90:a2:3a:50:f0:a6:03:6e:b3
11/12/2012 14:08:07: P1539:   NAS-Port = 1
11/12/2012 14:08:07: P1539:   Calling-Station-Id = 5555678
11/12/2012 14:08:07: P1539:   NAS-Identifier = localhost
11/12/2012 14:08:07: P1539: Using Client: localhost (127.0.0.1)
11/12/2012 14:08:07: P1539: Using NAS: localhost (127.0.0.1)
11/12/2012 14:08:07: P1539: Request is directly from a NAS: TRUE
11/12/2012 14:08:07: P1539: Authenticating and Authorizing with Service SouthBay
11/12/2012 14:08:07: P1539: Getting User user1's UserRecord from UserList SouthUsers
11/12/2012 14:08:07: P1539: User user1's password matches
11/12/2012 14:08:07: P1539: Processing User user1's check items
11/12/2012 14:08:07: P1539: Merging User user1's Attributes into response Dictionary
11/12/2012 14:08:07: P1539: Merging attributes into the Response Dictionary:
11/12/2012 14:08:07: P1539:   Adding attribute Callback-Number, value = 5551124
11/12/2012 14:08:07: P1539:   Adding attribute Session-Timeout, value = 60
```

```

11/12/2012 14:08:07: P1539: No default Remote Session Service defined.
11/12/2012 14:08:07: P1539: Trace of Access-Accept packet
11/12/2012 14:08:07: P1539:     identifier = 1
11/12/2012 14:08:07: P1539:     length = 35
11/12/2012 14:08:07: P1539:     reqauth = cc:2d:51:71:b5:49:0e:e6:f1:eb:1c:61:51:7a:f1:cb
11/12/2012 14:08:07: P1539:     Callback-Number = 5551124
11/12/2012 14:08:07: P1539:     Session-Timeout = 60
11/12/2012 14:08:07: P1539: Sending response to 127.0.0.1
11/12/2012 14:08:07: Log: Request from localhost (127.0.0.1): User user1 accepted

```

Configuring Profiles to Group Attributes

You can use the Cisco Prime AR profile object to group attributes. For example, you might want to group attributes for all PPP users. All PPP users could then be assigned the profile and the attributes contained in the profile would be returned in their access-accepts.

To configure profiles to group attributes:

-
- Step 1** Change directory to **/Radius/Profiles** and add a profile.

```
cd /Radius/Profiles
```

```
[ //localhost/Radius/Profiles ]
```

```
add PPP-Profile
```

```
Added PPP-Profile
```

- Step 2** Change directory to the new profile, then change directory to the profile's Attributes subdirectory.

```
cd PPP-Profile
```

```
[ //localhost/Radius/Profiles/PPP-Profile ]
```

```
cd Attributes
```

```
[ //localhost/Radius/Profiles/PPP-Profile/Attributes ]
```

- Step 3** Configure the desired attributes for the profile.

```
set Service-Type Framed
```

```
Set Service-Type Framed
```

```
set Framed-Protocol PPP
```

```
Set Framed-Protocol PPP
```

**Note**

When you need to set an attribute to a value that includes a space, you must double-quote the value, as in the following: *set Framed-Route* “192.168.1.0/24 192.168.1.1”

Step 4 Assign the profile to a user by setting the user’s BaseProfile attribute to the desired profile.

```
cd /Radius/UserLists/SouthUsers/User1
```

```
[ //localhost/Radius/UserLists/SouthUsers/user1 ]
```

```
set BaseProfile PPP-Profile
```

```
Set BaseProfile PPP-Profile
```

Configuring Return Attributes and Check-Items Using UserGroup

A profile can also be assigned to a UserGroup. You assign a profile to a group by setting the group’s BaseProfile attribute to the desired profile.

To configure return attributes and check-items using usergroup:

Step 1 Change directory to **/Radius/UserGroups** and add a UserGroup.

```
cd /Radius/UserGroups
```

```
[ //localhost/Radius/UserGroups ]
```

```
add PPP-Group
```

```
Added PPP-Group
```

Step 2 Change directory to the new UserGroup and add Return Attributes.

```
cd PPP-Group
```

```
[ //localhost/Radius/UserGroups/PPP-Group ]
```

```
cd Attributes
```

```
[ //localhost/Radius/UserGroups/PPP-Group/Attributes ]
```

```
set Service-Type Outbound
```

```
Set Service-Type Outbound
```

Step 3 Change directory to the UserGroups’ Check-Items subdirectory and add CheckItems.

```
cd ../CheckItems/
```

```
[ //localhost/Radius/UserGroups/PPP-Group/CheckItems ]
```

```
set Service-Type Framed
```

```
Set Service-Type Framed
```

Step 4 Assign the UserGroup to a User.

```
cd /Radius/UserLists/SouthUsers/User2
```

```
[ //localhost/Radius/UserLists/SouthUsers/user2 ]
```

```
set Group PPP-Group
```

```
Set Group PPP-Group
```

Return Attribute Precedence

Because there are multiple ways of returning attributes, you might at some time have an attribute clash. In case of an attribute clash, the attribute precedence is as follows (from highest to lowest):

1. User attribute
2. User profile
3. UserGroup attribute
4. UserGroup profile

aregcmd Command Performance

You can impact **aregcmd** command performance and server response time by having Cisco Prime AR userlists that contain more than 10,000 users. Cisco Prime AR userlists were not designed to contain 10,000 users in any one list.

If you must provide service for groups greater than 10000 users, Cisco recommends that you use an external data store such as an LDAP directory or an Oracle database. If you are unable to use an external data store, create multiple userlists instead, keeping each userlist under 10,000 users.

Multiple userlists require multiple services (one for each userlist), because a service cannot reference more than one userlist. The multiple services can then be combined using the Service Grouping feature with ResultRule, OR, as follows:

```
[ //localhost/Radius/Services/GroupService ]
  Name = GroupService
  Description =
  Type = group
  IncomingScript~ =
  OutgoingScript~ =
  ResultRule = OR
```

```

GroupServices/
1. UserService1
2. UserService2
3. UserService3

```

UserDefined1 Property

The UserDefined1 property of a user object is a free text field. You can use the UserDefined1 property to store additional user information much like the Description property, but its most powerful use is to pass information to an extension point script. The value set in the UserDefined1 property is automatically set to the environment variable of the same name during authentication. Any extension point script that subsequently runs has access the value in that property.

```

[ //localhost/Radius/UserLists/Default/bob ]
  Name = bob
  Description =
  Password = <encrypted>
  AllowNullPassword = FALSE
  Enabled = TRUE
  Group~ =
  BaseProfile~ =
  AuthenticationScript~ =
  AuthorizationScript~ =
  UserDefined1 =
  Attributes/
  CheckItems/

```

Access-Request Logging

By default, Cisco Prime AR logs all dropped and rejected requests in the name_radius_1_log file. The following are examples of log entries for dropped or rejected requests.

```

11/12/2012 17:38:11 name/radius/1 Warning Protocol 0 Request from localhost (127.0.0.1):
User user1 rejected (UserPasswordInvalid)
11/12/2012 18:05:12 name/radius/1 Warning Protocol 0 Packet from 128.107.132.106: that
address is not in the Clients list <unknown user>

```

To log all accepted requests as well, set the LogServerActivity advanced property to TRUE:

```
set /Radius/Advanced/LogServerActivity TRUE
```

```
Set /Radius/Advanced/LogServerActivity TRUE
```

```
save
```

```
Validating //localhost...
```

```
Saving //localhost...
```

reload

```
Reloading Server 'Radius'...
```

```
Server 'Radius' is Running, its health is 10 out of 10
```

```
Access-Accept packets are now logged as well:
```

```
11/12/2012 18:22:32 name/radius/1 Activity Protocol 0 Request from localhost (127.0.0.1):  
User user2 accepted
```



CHAPTER 7

RADIUS Accounting

This chapter describes RADIUS Accounting in Cisco Prime Access Registrar (Cisco Prime AR) as defined in Internet RFC 2866.

This chapter contains the following sections:

- [Understanding RADIUS Accounting](#)
- [Setting Up Accounting](#)
- [Oracle Accounting](#)
- [LDAP Accounting](#)
- [MySQL Support](#)
- [Proxying Accounting Records](#)
- [Accounting Log Examples](#)
- [Sample Error Messages](#)

Understanding RADIUS Accounting

RADIUS accounting is the process of collecting and storing the information contained in

- Accounting-Start and
- Accounting-Stop messages.

Internet RFC 2866 describes the protocol for sending accounting information between a Network Access Server (NAS) and a RADIUS server (or shared accounting server).



Note

Cisco Prime AR uses UDP port number 1646 as its default port for RADIUS accounting messages. RFC 2866 defines UDP port number 1813 as the accounting port number.

When a NAS that uses accounting begins a session, it sends an Accounting-Start packet describing the type of service and the user being connected to the Cisco Prime AR server. When the session ends, the NAS sends the RADIUS server an Accounting Stop packet describing the type of service that was delivered. The Accounting Stop packet might also contain statistics such as elapsed time, input and output octets, or input and output packets.

Setting Up Accounting

To configure Cisco Prime AR to perform accounting, you must do the following:

1. Create a service
2. Set the service type to file
3. Set the `DefaultAccountingService` field in `/Radius` to the name of the service you created

After you **save** and **reload** the Cisco Prime AR server configuration, the Cisco Prime AR server writes accounting messages to the **accounting.log** file in the `/opt/CSCOar/logs` directory. The Cisco Prime AR server stores information in the **accounting.log** file until a rollover event occurs. A rollover event is caused by the **accounting.log** file exceeding a pre-set size, a period of time transpiring, or on a scheduled date.

When the rollover event occurs, the data in **accounting.log** is stored in a file named by the prefix *accounting*, a date stamp (*yyyymmdd*), and the number of rollovers for that day. For example, **accounting-20121107-14** would be the 14th rollover on November 07, 2012.

The following shows the properties for a service called CiscoAccounting:

```
[ //localhost/Radius/Services/CiscoAccounting ]
  Name = CiscoAccounting
  Description =
  Type = file
  IncomingScript~ =
  OutgoingScript~ =
  OutagePolicy~ = RejectAll
  OutageScript~ =
  FilenamePrefix = accounting
  MaxFileSize = "10 Megabytes"
  MaxFileAge = "1 Day"
  RolloverSchedule =
  UseLocalTimeZone = FALSE
```

Accounting Log File Rollover

The Cisco Prime AR accounting functionality provides flexibility in managing the accounting log. You can configure the Cisco Prime AR server to rollover the accounting log using any combination of the following Cisco Prime AR accounting service properties:

- `MaxFileSize`—Indicates the maximum size of the accounting log file in KB, MB, or GB
- `MaxFileAge`—Indicates the maximum age of the log file in minutes, hours, days, or weeks
- `RolloverSchedule`—Indicates the exact time including the day of the month or day of the week, hour and minute to roll over the accounting log file

You can configure an accounting service using any combination of `MaxFileSize`, `MaxFileAge`, and `RolloverSchedule`. For example, you might configure `RolloverSchedule` and `MaxFileAge` at the same time. This would be useful if you wanted to have an age-based rollover, but also synchronize to an absolute clock at specified times. The following would set a rollover every twelve hours at 11:59 and 12:59.

```
set MaxFileAge "12 H"
```

```
set RolloverSchedule "59 11,12 * * *"
```

You might also consider scheduling `MaxFileAge` to be six minutes and set `RolloverSchedule` to the top of the hour. The following would create ten six-minute long files starting anew every hour.

```
set MaxFileAge "6 Minutes"
```

```
set RolloverSchedule "0 * * * *"
```

Although you specify an exact time with the `RolloverSchedule` property, the Cisco Prime AR server only checks the rollover schedule when an accounting event occurs. If your Cisco Prime AR server receives a steady flow of packets (at least one per minute), the times you specify are accurate. However, if the Cisco Prime AR server does not receive any packets for a period of time, no rollovers will occur until the next packet is received. The same is true for `MaxFileAge` and `MaxFileSize`.

Based on the maximum file size and the age specified, Cisco Prime AR closes the accounting file, moves it to a new name, and reopens the file as a new file. The name given to this accounting file depends on its creation and modification dates.

For example, if the file was created and modified on the same date, the filename will be of the format `FileNamePrefix-<yyyymmdd>-<n>.log`, and the suffix will have year, month, day, and number. If the file was created on some day and modified on another, the filename will be of the format `FileNamePrefix-<yyyymmdd>-<yyyymmdd>-<n>.log`, and the suffix will have creation date, modification date, and number.

This section contains the following topics:

- [FilenamePrefix](#)
- [MaxFileSize](#)
- [MaxFileAge](#)
- [RolloverSchedule](#)
- [UseLocalTimeZone](#)

FilenamePrefix

The `FileNamePrefix` property enables you to specify a path to the file system in which you store the log files. If you do not manage your log files regularly, they might use the system resources, which will affect the performance of the Cisco Prime AR server.

Cisco recommends that you store the log files in a file system different from the file system where you installed the Cisco Prime AR software by specifying the path in the `FilenamePrefix` property. By doing so the Cisco Prime AR server continues to run, even if the accounting logs fill the file system.

The following example specifies the `/usr/arlogs/accounting` as the `FilenamePrefix`:

```
set /Radius/Services/CiscoAccounting/FilenamePrefix /usr/arlogs/accounting
```

You can also set up a *cron job* to check the size of the log files and mail the administrator if the file system is full.

MaxFileSize

Use `MaxFileSize` to indicate the maximum size of the `accounting.log` file in minutes, hours, days, or weeks. `MaxFileAge` measures the age of the `accounting.log` file from the time the previous file rollover occurred.

You can specify the following (case insensitive) file sizes:

- K, Kilobytes, Kilobytes
- M, Megabyte, Megabytes
- G, Gigabyte, Gigabytes

The following are examples of valid commands to set MaxFileSize:

```
set MaxFileSize "500 kilobytes"
```

The example above sets a MaxFileSize of 500 kilobytes

```
set maxfilesize "1 G"
```

The example above sets a MaxFileSize of one gigabyte

```
set maxfilesize "200 megabyte"
```

The example above sets a MaxFileSize of 200 megabytes

MaxFileAge

Use MaxFileAge to indicate the maximum age of the log file in minutes, hours, days, or weeks. MaxFileAge measures the age of the **accounting.log** file from the time the previous file rollover occurred.

You can specify the following (case insensitive) periods of time:

- M, Minute, or Minutes preceded by a number from 0 to 59
- H, Hour, or Hours preceded by a number from 0 to 12
- D, Day, or Days preceded by a number from 1 to 31
- W, Week, or Weeks preceded by a number from 1 to 52

The following are examples of valid commands to set MaxFileAge:

```
set MaxFileAge "6 Minutes"
```

The example above sets a MaxFileAge of 6 minutes.

```
set maxfileage "2 d"
```

The example above sets a MaxFileAge of two days.

```
set maxfileage "1 H"
```

The example above sets a MaxFileAge of one hour.

RolloverSchedule

You set RolloverSchedule using the following crontab-style time format:

```
minute hour "day of month" "month of year" "day of week"
```

Where:

- Minute is a value from 0-59

- Hour is a value from 0-12
- Day (of the month) is a value from 1-31
- Month is a value from 1-12
- Day (of the week) is a value from 0-6, where 0 is Sunday

UseLocalTimeZone

When set to TRUE, the Cisco Prime AR server stores the accounting records in the log using the local system time. When set to FALSE (the default), Cisco Prime AR stores the accounting records in the log using Greenwich Mean Time (GMT).

Oracle Accounting

Previous releases of Cisco Prime AR supported accessing user data from an Oracle database using Open Database Connectivity (ODBC), but this feature was limited to performing authentication and authorization (AA). You could only write the accounting records to local file or proxy to another RADIUS server.

Cisco Prime AR supports writing accounting records into Oracle database enabling integration between billing systems and Oracle.

- Cisco Prime AR adds a new type of service and remote server called *odbc-accounting* that enables inserting accounting records into Oracle.
- You can write accounting records into Oracle by referring this service in **/Radius/DefaultAccountingService** or in the Accounting-Service environment variable.

There is no specified schema structure to use the Oracle accounting feature. You can use your own table design and configure insert statements using standard SQL in the Cisco Prime AR configuration. The Cisco Prime AR server executes the insert statements to write the accounting record into Oracle. This feature is similar to the existing ODBC feature which performs authentication and authorization.

To improve latency for writing accounting records into database, packet buffering can be used. This option is enabled using the *BufferAccountingPackets* property under the *odbc-accounting* remote server definition.



Note

Cisco Prime AR supports Oracle 10g client and 11g server.



Note

For more information about dynamic SQL feature, see [Dynamic SQL Feature, page 7-10](#).

This section contains the following topics:

- [Configuring Oracle Accounting](#)
- [Packet Buffering](#)
- [Dynamic SQL Feature](#)

Configuring Oracle Accounting

To use the Oracle accounting feature,

- you must configure a service of type *odbc-accounting* under **/Radius/Services**.
- you must also configure at least one remote servers of type *odbc-accounting* under **/Radius/RemoteServers**.

This section contains the following topics:

- [ODBC-Accounting Service](#)
- [Configuring Oracle Accounting](#)
- [ODBC RemoteServers](#)
- [Configuration Examples](#)
- [Packet Buffering](#)
- [Dynamic SQL Feature](#)

ODBC-Accounting Service

The following is an example of an ODBC-Accounting service:

```
[ //localhost/Radius/Services/oracle_accounting ]
  Name = oracle_accounting
  Description =
  Type = odbc-accounting
  IncomingScript~ =
  OutgoingScript~ =
  OutagePolicy~ = RejectAll
  OutageScript~ =
  MultipleServersPolicy = Failover
  RemoteServers/
    1. accounting_server
```

ODBC RemoteServers

Create a remote server under **/Radius/RemoteServers**, and set its protocol to *odbc-accounting*. The following is an example of an ODBC-Accounting RemoteServer's configuration:

```
[ //localhost/Radius/RemoteServers/accounting_server ]
  Name = accounting_server
  Description =
  Protocol = odbc-accounting
  ReactivateTimerInterval = 300000
  Timeout = 15
  DataSourceConnections = 8
  ODBCDataSource =
  KeepAliveTimerInterval = 0
  BufferAccountingPackets = TRUE
  MaximumBufferFileSize = "10 Megabytes"
  NumberOfRetriesForBufferedPacket = 3
  BackingStoreEnvironmentVariables =
  UseLocalTimeZone = FALSE
  AttributeList =
  Delimiter =
  SQLDefinition/
```

Table 7-1 describes the ODBC RemoteServer properties.

Table 7-1 ODBC RemoteServer Properties

Property	Description
Name	Name of the remote server; this property is mandatory, and there is no default
Description	Optional description of server
Protocol	Must be set to <code>odbc-accounting</code>
ReactivateTimerInterval	Mandatory time interval (in milliseconds) to activate an inactive server; defaults to 300000 ms.
Timeout	Mandatory time interval (in seconds) to wait for SQL operation to complete; defaults to 15 seconds
DataSourceConnections	Mandatory number of connections to be established; defaults to 8
ODBCDataSource	Name of the ODBCDataSource to use and must refer to one entry in the list of ODBC datasources configured under /Radius/Advanced/ODBCDataSources . Mandatory; no default
KeepAliveTimerInterval	Mandatory time interval (in milliseconds) to send a keepalive to keep the idle connection active; defaults to zero (0) meaning the option is disabled
BufferAccountingPackets	Mandatory, TRUE or FALSE, determines whether to buffer the accounting packets to local file, defaults to TRUE which means that packet buffering is enabled
MaximumBufferFileSize	Mandatory if BufferAccountingPackets is set to TRUE, determines the maximum buffer file size, defaults to 10 Megabyte)
NumberOfRetriesForBufferedPacket	Mandatory if BufferAccountingPackets is set to TRUE. A number greater than zero determines the number of attempts to be made to insert the buffered packet into Oracle. Defaults to 3.
BackingStoreEnvironmentVariables	Optional; when BufferAccountingPackets is set to TRUE, contains a comma-separated list of environment variable names to be stored into a local file along with buffered packet. No default. BackingStoreEnvironmentVariables can also be specified in scripts using the BackingStoreEnvironmentVariables environment variable.
UseLocalTimeZone	Set to TRUE or FALSE, determines the timezone of accounting records' TimeStamp (defaults to FALSE).
AttributeList	List of comma-separated attribute names.
Delimiter	Character used to separate the values of the attributes given in AttributeList property.
SQLDefinition	List of insert, update and delete statements to be executed to insert, update and delete the accounting record.

It is mandatory to set MaximumBufferFileSize property if BufferAccountingPackets property is set to TRUE. MaximumBufferFileSize can be specified in Kilobytes, Megabytes and Gigabytes. All values "512 kilobytes", "512 k", "512 KB" are valid for specifying 512 kilobytes.

If buffering is enabled, incoming packets will be accepted and logged to local file until the configured buffer file size is reached even if the database is offline. Attempts to insert them into Oracle will be made when database becomes available. This remote server will be marked as down only when the buffer gets

full. So, having two odbc-accounting remote servers in the service, first one with buffering enabled and multiple server policy of FailOver will make the other remote servers to receive packets only when the first remote server's buffer gets full.

AttributeList is to specify the list of attribute names separated with comma. When this 'AttributeList' is given in the MarkerList, these attributes' values will be appended together with delimiter specified in 'Delimiter' property and will be supplied as input to that marker.

Attributes from the Cisco Prime AR environment and request dictionaries can be specified in the MarkerList. Request dictionary will be looked up first for the attributes. Other than the standard attributes in the Cisco Prime AR dictionaries, two new marker variables are supported inside the marker list. They are,

- **TimeStamp**—Used to insert the timestamp into Oracle from Cisco Prime AR. Specifying this will supply the timestamp of that accounting record as a value to the insert statement. Time zone of this timestamp will be local if UseLocalTimeZone property is set to TRUE, otherwise GMT. This functionality could also be achieved by employing a trigger on the accounting table in the database. However, using this marker variable is recommended because the use of triggers negatively affects performance.

The format of the timestamp marker variable supplied by Cisco Prime AR is *YYYYMMDDHH24MMSS*. For example, a timestamp of 20121107211050 represents 21:10:50, November 07, 2012.

- **RawAcctRecord**—Used to insert the entire accounting record into the database as a single text field. Contents of this will be whatever is sent by the NAS in the accounting packet and the format is *name=value* pairs delimited with the string specified in Delimiter property. If the delimiter property is not set, the default delimiter is a new line character. RawAcctRecord can be used with the other marker variables.

If multivalued attributes are specified in the marker list, the multiple values are concatenated together with delimiters, and the resulting value will be passed to the insert statement. This delimiter can be specified using the ODBCEnvironmentMultiValueDelimiter property under **/Radius/Advanced**.

Configuration Examples

This section provides common Oracle accounting configuration examples most likely to be used.

This section contains the following topics:

- [Inserting Selected Attributes into Separate Columns](#)
- [Inserting Complete Accounting Packets into One Column](#)
- [Inserting Selected Attributes into One Column](#)
- [Updating Selected Attributes](#)
- [Deleting Selected Attributes](#)

Inserting Selected Attributes into Separate Columns

Use the following SQL and MarkerList properties statement to insert selected attributes into separate Oracle columns. The Oracle table definition will have separate columns for each attribute.

```
SQL: "insert into ar_acct (username,nasinfo,packet_type,timestamp) values (?, ?, ?, ?)"
MarkerList: "UserName/SQL_CHAR NAS-Identifier/SQL_CHAR Acct-Status-Type/SQL_CHAR
TimeStamp/SQL_TIMESTAMP"
```

In this example, all the column data types are CHAR/VARCHAR except the timestamp which is DATE. If packet buffering option is disabled, instead of TimeStamp marker, you can also use Oracle's **sysdate** as a value for the timestamp column. The insert statement will look like the following:

```
"insert into ar_acct (username,nasinfo,packet_type,timestamp) values (?, ?, ?, sysdate)"
```

Inserting Complete Accounting Packets into One Column

Use SQL and MarkerList properties in the SQLStatement like the following to insert the complete accounting packet into one Oracle column.

```
SQL: "insert into ar_acct (timestamp,raw_packet) values (?,?)"
MarkerList: "TimeStamp/SQL_TIMESTAMP RawAcctRecord/SQL_VARCHAR"
```

Inserting Selected Attributes into One Column

To insert selected attribute values into one Oracle column delimited by a comma (,), you must configure the AttributeList and Delimiter properties of the odbc-accounting RemoteServer object like the following:

```
AttributeList = "NAS-Identifier,NAS-Port,Acct-Status-Type,Acct-Session-Id"
Delimiter = ,
```

The SQL and MarkerList properties in the SQLStatement will look like the following:

```
SQL: "insert into ar_acct (username,timestamp,attributes) values (?, ?, ?)"
MarkerList: "UserName/SQL_CHAR TimeStamp/SQL_TIMESTAMP AttributeList/SQL_VARCHAR"
```

Updating Selected Attributes

Use the following SQL and MarkerList properties statement to update the selected attributes:

```
SQL: "update arusers_acct set acct_status_type='stop' where username=? and
acct_status_type=?"
MarkerList: "UserName/SQL_CHAR Acct-Status-Type/SQL_CHAR"
```

Deleting Selected Attributes

Use the following SQL and MarkerList properties statement to delete the selected attributes:

```
SQL = "delete from arusers_acct where username=?"
MarkerList = UserName/SQL_CHAR
```

Packet Buffering

You can optionally use packet buffering to improve latency when writing accounting records into the database. To enable packet buffering,

- set the BufferAccountingPackets property in the odbc-accounting remote server to TRUE.

This section contains the following topics:

- [When Using Packet Buffering](#)
- [With Packet Buffering Disabled](#)

When Using Packet Buffering

When `BufferAccountingPackets` is set to `TRUE`, the Cisco Prime AR server's Accounting-Response is returned as soon as the accounting record is successfully written to the local file. To accomplish the queuing of accounting records to a local file, a variant of the existing session backing store is used.

- **Buffered packets** will be inserted into Oracle by a set of background worker threads. The Cisco Prime AR server tries to insert the buffered packet into Oracle for the number of retries configured in the `NumberOfRetriesForBufferedPacket` property (remote `odbc` accounting server definition). After the configured number of retries, the buffered packets are discarded from the local file.
- **Incoming packets** will be buffered to local file until the configured `MaximumBufferFileSize` is reached. After this limit is reached, no more packets will be addressed. When the database is offline, this remote server will continue to take incoming packets until `MaximumBufferFileSize` reaches. Cisco Prime AR tries to insert these buffered packets when database becomes available.

When using packet buffering, the Cisco Prime AR server can process more incoming packets and can reduce the bottleneck that could occur if the number of simultaneous incoming packets is large and the number of connections to the database is less.

With Packet Buffering Disabled

When `BufferAccountingPackets` is set to `FALSE`, Accounting-Response is returned after writing the accounting record into Oracle. Oracle write timing is immediate.

- Incoming packets are acknowledged by the remote server only after completing the write into Oracle.
- When the database is offline, no incoming packets are addressed. A slow database server impacts the packet processing rate.

Dynamic SQL Feature

Using this feature, you can choose the list of SQL statements and the sequence in which the SQL statements need to be executed during run time. This is done through the usage of scripting points.

The `SQL-Sequence` variable is provided in the Environment Dictionary and it takes the list of SQL statement names and separates each statement name by a semicolon (;). For example, the SQL statement names 'sql3', 'sql4', and 'sql5' are denoted as `sql3;sql4;sql5;`.

While being processed, the packet will be checked for the status of the `SQL-Sequence` variable. If the variable is set, the list of SQL statements will be executed in the order specified. Even if one of the SQL statements is not found in the configured list of SQL statements, the packet processing fails.

When configured for packet buffering, the `BackingStore` variable in the Environment Dictionary should have the `SQL-Sequence` variable in order to buffer the `SQL-Sequence` variable along with the packet information.

LDAP Accounting

Previous releases of Cisco Prime AR, supported accessing user data from an LDAP server, but this feature was limited to performing authentication and authorization (AA). You can only write the accounting records to local file or Oracle database or proxy to another RADIUS server.

Cisco Prime AR supports writing accounting records into LDAP server enabling integration between billing systems and LDAP.

- Cisco Prime AR adds a new type of service and remote server called `ldap-accounting` that enables inserting accounting records into LDAP.
- You can write accounting records into LDAP by referring this service in `/Radius/DefaultAccountingService` or in the `Accounting-Service` environment variable.

There is no specified schema structure to use the LDAP accounting feature. You can use your own object class design and configure, insert data using `AttributesToWrite` object in the Cisco Prime AR configuration. The Cisco Prime AR server inserts all configured attributes to write the accounting record into LDAP server. This feature is similar to the existing LDAP feature which performs authentication and authorization.



Note

Cisco Prime AR supports LDAP version 3 client and LDAP version 3 server.

Configuring LDAP Accounting

To use the `ldap-accounting` feature,

- you must configure a service of type `ldap-accounting` under `/Radius/Services`.
- You must also configure at least one remote servers of type `ldap-accounting` under `/Radius/RemoteServers`.

This section contains the following topics:

- [LDAP-Accounting Service](#)
- [LDAP RemoteServers](#)
- [Configuration Examples](#)
- [Configuring the LDAP Service for Accounting](#)
- [Configuring an LDAP-Accounting RemoteServer](#)
- [Setting LDAP-Accounting As Accounting Service](#)

LDAP-Accounting Service

The following is an example of the LDAP-Accounting service:

```
[ //localhost/Radius/Services/ldap_accounting ]
  Name = ldap_accounting
  Description =
  Type = ldap-accounting
  IncomingScript~ =
  OutgoingScript~ =
  OutagePolicy~ = RejectAll
  OutageScript~ =
  MultipleServersPolicy = Failover
  RemoteServers/
    1. accounting_server
```

LDAP RemoteServers

Create a remote server under **/Radius/RemoteServers**, and set its protocol to `ldap-accounting`. The following is an example of an LDAP-Accounting RemoteServer's configuration:

```
[ //localhost/Radius/RemoteServers/accounting_server ]
  Name = accounting_server
  Description =
  Protocol = ldap-accounting
  Port = 389
  ReactivateTimerInterval = 300000
  Timeout = 15
  HostName =
  BindName =
  BindPassword =
  UseSSL = FALSE
  EnableKeepAlive = FALSE
  DnPath~ =
  EntryName~ = (uid=%s)
  ObjectClass =
  AttributeList =
  Delimiter =
  LDAPEnvironmentMultiValueDelimiter =
  LimitOutstandingRequests = FALSE
  MaxOutstandingRequests = 0
  EscapeSpecialCharInUserName = FALSE
  DNSLookupAndLDAPRebindInterval =
  DataSourceConnections = 1
  UseLocalTimeZone = FALSE
  AttributesToWrite/
```

Table 7-2 lists the properties of LDAP-Accounting RemoteServer.

Table 7-2 LDAP-Accounting RemoteServer Properties

Fields	Description
Name	Name of the remote server; this property is mandatory and there is no default.
Description	Optional description of server.
Protocol	Must be set to <code>ldap-accounting</code> .
ReactivateTimerInterval	Mandatory time interval (in milliseconds) to activate an inactive server; defaults to 300000 ms.
Timeout	Mandatory time interval (in seconds) to wait for LDAP-write operation to complete; defaults to 15 seconds.
DataSourceConnections	Mandatory number of connections to be established; defaults to 8.
EnableKeepAlive	Required; default is FALSE. This is enabled to send a TCP keepalive to keep the idle connection active.
HostName	Required; the LDAP server's hostname or IP address.
BindName	Optional; the distinguished name (dn) to use when establishing a connection between the LDAP and RADIUS servers.
BindPassword	Optional; the password associated with the BindName .
DnPath	Required; the path that indicates where in the LDAP database to start the write for user information.

Table 7-2 LDAP-Accounting RemoteServer Properties (continued)

Fields	Description
EntryName	Required; this specifies the write entry name Cisco Prime AR uses when inserting the LDAP server for user information. When you configure this property, use the notation "%s" to indicate where the user ID should be inserted. For example, a typical value for this property is "(uid=%s)," which means that when inserting for information about user joe, use the fentry name uid=joe.
UseLocalTimeZone	Optional; the default is FALSE. It determines the timezone of accounting records TimeStamp.
AttributeList	List of comma-separated attribute names.
Delimiter	Character used to separate the values of the attributes given in AttributeList property.
AttributesToWrite	List of inserts to be executed to insert the accounting record.
ObjectClass	Required; list of object classes which are all schemas defined in LDAP server. These schemas define required attributes and allowed attributes for an entry which is inserted from Cisco Prime AR.
LDAPEnvironmentMultiValue Delimiter	Optional; allows you to specify a character that separates multi-valued attribute lists when using ldap-accounting.
LimitOutstandingRequests	Required; the default is FALSE. Cisco Prime AR uses this property in conjunction with the MaxOutstandingRequests property to tune the RADIUS server's use of the LDAP server. When you set this property to TRUE, the number of outstanding requests for this RemoteServer is limited to the value you specified in MaxOutstandingRequests . When the number of requests exceeds this number, Cisco Prime AR queues the remaining requests, and sends them as soon as the number of outstanding requests drops to this number.
MaxOutstandingRequests	Required when you have set the LimitOutstandingRequests to TRUE. The number you specify, which must be greater than zero, determines the maximum number of outstanding requests allowed for this remote server.
EscapeSpecialCharInUserName	FALSE by default.
UseSSL	A boolean field indicating whether you want Cisco Prime AR to use SSL (Secure Socket Layer) when communicating with this RemoteServer. When you set it to TRUE, be sure to specify the CertificateDBPath field in the Advanced section, and be sure the port you specified for this RemoteServer is the SSL port used by the LDAP server.

AttributeList is to specify the list of attribute names separated with comma. When this 'AttributeList' is given in the 'AttributesToWrite' object, these attribute values will be appended together with delimiter specified in 'Delimiter' property and will be supplied as input to that ldap field name.

Attributes from the Cisco Prime AR environment and request dictionaries can be specified in the 'AttributesToWrite' object. Request dictionary will be looked up first for the attributes. Other than the standard attributes in the Cisco Prime AR dictionaries, two new variables are supported inside the 'AttributesToWrite' object. They are:

- **TimeStamp**—Used to insert the timestamp into LDAP server from Cisco Prime AR. Specifying this will supply the timestamp of that accounting record as a value to the insert. Time zone of this timestamp will be local if UseLocalTimeZone property is set to TRUE, otherwise GMT. This functionality could also be achieved by employing a trigger on the accounting object class in the server.

The format of the timestamp variable supplied by Cisco Prime AR is *YYYYMMDDHH24MMSS*. For example, a timestamp of 20121107211050 represents 21:10:50, November 07, 2012.

- **RawAcctRecord**—Used to insert the entire accounting record into the database as a single text field. Contents of this will be whatever is sent by the NAS in the accounting packet and the format is name=value pairs delimited with the string specified in Delimiter property. If the delimiter property is not set, the default delimiter is a ‘;’ character. RawAcctRecord can be used with the other variables.

If multivalued attributes are specified in the attribute list, the multiple values are concatenated together with delimiters, and the resulting value will be passed to the insert statement. This delimiter can be specified using the LDAPEnvironmentMultiValueDelimiter property.

Configuration Examples

This section provides common LDAP accounting configuration examples most likely to be used.

This section contains the following topics:

- [Inserting Selected Attributes into Separate LDAP Field](#)
- [Inserting Complete Accounting Packets into One Field](#)
- [Inserting Selected Attributes into One Field](#)

Inserting Selected Attributes into Separate LDAP Field

Use the following ObjectClass property and ‘AttributesToWrite’ object properties statement to insert selected attributes into separate LDAP schema. The LDAP schema definition will have separate fields for each attribute.

```
[//localhost/Radius/RemoteServers/accounting-server/AttributesToWrite ]
  sn = timestamp
  uid = username
```

Inserting Complete Accounting Packets into One Field

Use ObjectClass and ‘AttributesToWrite’ object properties in the ldap-accounting remote server like the following to insert the complete accounting packet into one LDAP field.

```
[ //localhost/Radius/RemoteServers/accounting-server/AttributeWrites ]
  seealso = rawacctrecord
  uid = username
```

Inserting Selected Attributes into One Field

To insert selected attribute values into one LDAP field delimited by a comma (,), you must configure the AttributeList and Delimiter properties of the ldap-accounting RemoteServer object like the following:

```
AttributeList = User-Name,NAS-Port,Acct-Session-Id
Delimiter = ,
AttributeWrites/
telephonenumber = attributelist
```

```
uid = username
```

Configuring the LDAP Service for Accounting

You configure an LDAP-Accounting service under /Radius/Services. When you define an LDAP-Accounting service under /Radius/Services, you must set its type to ldap-accounting.

```
[ //localhost/Radius/Services/AR-LDAP-ACCT ]
  Name = AR-LDAP-ACCT
  Description =
  Type = ldap-accounting
  IncomingScript~ =
  OutgoingScript~ =
  OutagePolicy~ = RejectAll
  OutageScript~ =
  MultipleServersPolicy = Failover
  Remoteservers/
```

Table 7-3 LDAP-Accounting Service Properties

Fields	Description
Name	Required; inherited from the upper directory.
Description	An optional description of the service.
Type	Must be set to LDAP for LDAP service.
IncomingScript	Optional.
OutgoingScript	Optional.
OutagePolicy	Required; must be set to AcceptAll or Drop Packet, or defaults to RejectAll.
OutageScript	Optional. if you set this property to the name of a script, Cisco Prime AR runs it when an outage occurs. This property allows you to create a script that notifies you when the RADIUS server detects a failure.
MultipleServersPolicy	Required; must be set to RoundRobin or defaults to Failover.
RemoteServers	Required; list of one or more remote servers defined under /Radius/Services/LDAP/RemoteServers. These servers must be listed in.

This section contains the following topics:

- [MultipleServersPolicy](#)
- [RemoteServers](#)

MultipleServersPolicy

Use the MultipleServersPolicy property to configure the LDAP remote servers in RoundRobin mode, or the default Failover mode applies. When set to Failover, Cisco Prime AR directs requests to the first server in the /Radius/Services/LDAP/RemoteServers list. If that server should fail or go offline, Cisco Prime AR redirects all requests to the next server in the list. The process continues until Cisco Prime AR locates an online server.

When set to RoundRobin, Cisco Prime AR directs each request to the next server in the RemoteServers list to share the resource load across all listed servers.

RemoteServers

Use the RemoteServers directory to list one or more remote servers to process access requests. The servers must also be listed in order under **/Radius/RemoteServers**.

The order of the RemoteServers list determines the sequence for directing access requests when MultipleServersPolicy is set to RoundRobin mode. The first server in the list receives all access requests when MultipleServersPolicy is set to Failover mode.

Configuring an LDAP-Accounting RemoteServer

Use the **aregcmd** command **add** to add LDAP servers under **/Radius/RemoteServers**. You must configure an LDAP RemoteServer object for each RemoteServer object you list under **/Radius/Services/LDAP/RemoteServers**.

The Name, Protocol, Port, HostName, BindName, BindPassword, DnPath, and EntryName properties must be configured to use an LDAP remote server.

Table 7-4 LDAP Remote Server Properties

Fields	Description
Name	Name of the remote server; this property is mandatory and there is no default.
Description	Optional description of server.
Protocol	Must be set to ldap-accounting.
ReactivateTimerInterval	Mandatory time interval (in milliseconds) to activate an inactive server; defaults to 300000 ms.
Timeout	Mandatory time interval (in seconds) to wait for LADP-write operation to complete; defaults to 15 seconds
DataSourceConnections	Mandatory number of connections to be established; defaults to 8.
EnableKeepAlive	Mandatory field which is enabled to send a TCP keepalive to keep the idle connection active; defaults to FALSE meaning the option is disabled.
HostName	Required; the LDAP server's hostname or IP address.
BindName	Optional; the distinguished name (dn) to use when establishing a connection between the LDAP and RADIUS servers.
BindPassword	Optional; the password associated with the BindName .
DnPath	Required; the path that indicates where in the LDAP database to start the write for user information.
EntryName	Required; this specifies the write entry name Cisco Prime AR uses when inserting the LDAP server for user information. When you configure this property, use the notation "%s" to indicate where the user ID should be inserted. For example, a typical value for this property is "(uid=%s)," which means that when inserting for information about user joe, use the fentry name uid=joe.

Table 7-4 LDAP Remote Server Properties (continued)

Fields	Description
UseLocalTimeZone	Set to TRUE or FALSE, determines the timezone of accounting records' TimeStamp (defaults to FALSE).
AttributeList	List of comma-separated attribute names.
Delimiter	Character used to separate the values of the attributes given in AttributeList property.
AttributesToWrite	List of inserts to be executed to insert the accounting record.
ObjectClass	Required; list of object classes which are all schemas defined in LDAP server. These schemas define required attributes and allowed attributes for an entry which is inserted from Cisco Prime AR.
LDAPEnvironmentMultiValue Delimiter	Optional; allows you to specify a character that separates multi-valued attribute lists when using ldap-accounting.
LimitOutstandingRequests	Required; the default is FALSE. Cisco Prime AR uses this property in conjunction with the MaxOutstandingRequests property to tune the RADIUS server's use of the LDAP server. When you set this property to TRUE, the number of outstanding requests for this RemoteServer is limited to the value you specified in MaxOutstandingRequests . When the number of requests exceeds this number, Cisco Prime AR queues the remaining requests, and sends them as soon as the number of outstanding requests drops to this number.
MaxOutstandingRequests	Required when you have set the LimitOutstandingRequests to TRUE. The number you specify, which must be greater than zero, determines the maximum number of outstanding requests allowed for this remote server.
EscapeSpecialCharInUserName	FALSE by default.
UseSSL	A boolean field indicating whether you want Cisco Prime AR to use SSL (Secure Socket Layer) when communicating with this RemoteServer. When you set it to TRUE, be sure to specify the CertificateDBPath field in the Advanced section, and be sure the port you specified for this RemoteServer is the SSL port used by the LDAP server.

DNS Look Up and LDAP Rebind Interval

Cisco Prime AR provides a DNS Look-up and LDAP Rebind feature that enables you to use a smart DNS server for LDAP hostname resolution, allows you to query a DNS server at set intervals to resolve the LDAP hostname, and optionally rebind to the LDAP server, if necessary.

When you configure Cisco Prime AR to use an LDAP directory server, you can specify the hostname of the LDAP directory server. The hostname can be a qualified or an unqualified name. You can also specify a timeout period after which Cisco Prime AR will again resolve the hostname. If the IP address returned is different from the previous, Cisco Prime AR establishes a new LDAP bind connection.

The `DNSLookupAndLDAPRebindInterval` property specifies the timeout period after which the Cisco Prime AR server will attempt to resolve the LDAP hostname to IP address (DNS resolution). When you do not modify `DNSLookupAndLDAPRebindInterval`, the default value zero indicates the server will perform normal connection and binding only at start-up time or during a reload. Unless you change the default to a value greater than zero, the server will not perform periodic DNS lookups.

Cisco Prime AR maintains and uses the existing bind connection until a new one is established to minimize any performance impact during the transfer. Cisco Prime AR ensures that no requests are dropped or lost during the transfer to a new LDAP binding.

Set the `DNSLookupAndLDAPRebindInterval` using a numerical value and the letter H for hours or M for minutes, such as in the following examples:

```
set DNSLookupAndLDAPRebindInterval 15M—performs DNS resolution every 15 minutes
```

**Note**

We recommend that you do not set `DNSLookupAndLDAPRebindInterval` to a value less than 15 minutes to minimize its effect on server performance.

```
set DNSLookupAndLDAPRebindInterval 1h—performs DNS resolution every hour
```

Configuring the DNS Look-up and LDAP Rebind

To configure the DNS Look-up and LDAP Rebind:

- Step 1** Log in to the Cisco Prime AR server, and use `aregcmd` to navigate to `//localhost/Radius/Remoteservers`. If necessary, add the LDAP server, or change directory to it.

```
cd /Radius/RemoteServers/ldap-serv1/
```

- Step 2** Set the `DNSLookupAndLDAPRebindInterval` property to the interval time desired.

```
set DNSLookupAndLDAPRebindInterval 30 M
```

LDAP Rebind Failures

Cisco Prime AR records any name resolution failures, bind successes and failures, and the destination hostname and IP address in the log file. At trace level 3, Cisco Prime AR also logs the time of any new bind connections and the closing of any old bind connections.

If either the name resolution or bind attempt fail, Cisco Prime AR continues using the existing bind connection until the timeout has expired again. If there is no existing bind connection, Cisco Prime AR marks the remote server object as *down*.

Setting LDAP-Accounting As Accounting Service

Use `aregcmd` to configure the LDAP-accounting Service as the default accounting service under `/Radius` as in the following:

```
set DefaultAccountingService AR-LDAP-ACCT
```

MySQL Support

Cisco Prime AR provides support for MySQL to query user records from a MySQL database using odbc interface and enables you to write accounting records into MySQL database using odbc-accounting. Cisco Prime AR has been tested with MySQL 5.0.90 and MyODBC 3.51.27 (reentrant).

For the Cisco Prime AR server to use MySQL, you must create and configure an ODBCDataSource object of type myodbc and a RemoteServer object set to protocol odbc.

**Note**

For more information about dynamic SQL feature, see [Dynamic SQL Feature, page 7-10](#).

This section contains the following topics:

- [Configuring MySQL](#)
- [Example Configuration](#)

Configuring MySQL

To configure the Cisco Prime AR server to query records from a MySQL database:

-
- Step 1** Log in to the Cisco Prime AR server and launch **aregcmd**.
Log in as a user with administrative rights such as user **admin**.
- Step 2** Change directory to the **/Radius/Advanced/ODBCDataSources** and add a new ODBCDataSource.
- ```
cd /Radius/Advanced/ODBCDataSources
add mysql
```
- Step 3** Set the new ODBCDataSource type to myodbc.
- ```
cd mysql  
set type myodbc
```
- Step 4** Set the Driver property to the path of the MyODBC library.
- Step 5** Set the UserID property to a valid username for the MyODBC database and provide a valid password for this user.
- Step 6** Provide a DataBase name and the name of the Cisco Prime AR RemoteServer object to associate with the ODBCDataSource.
- Step 7** Change directory to **/Radius/RemoteServers** and add a RemoteServer object to associate with the new ODBCDataSource.
- ```
cd /Radius/RemoteServers
add mysql
```
- Step 8** Change directory to the new RemoteServer and set its protocol to odbc-accounting.
- ```
cd mysql
```

set protocol odbc-accounting

Step 9 Set the ODBCDataSource property to the name of the ODBCDataSource to associate with this RemoteServer object.

set ODBCDataSource mysql

Example Configuration

The following shows an example configuration for a MySQL ODBC data source.

```
[ //localhost/Radius/Advanced/ODBCDataSources/mysql ]
Name = mysql
Type = myodbc
Driver = /tmp/libmyodbc3_r.so
UserID = mysql
Password = <encrypted>
DataBase = test
Server = mysql-a
Port = 3306
```

The following shows an example configuration for a RemoteServer

```
Name = odbc-accounting
Description =
Protocol = odbc-accounting
ReactivateTimerInterval = 300000
Timeout = 15
DataSourceConnections = 8
ODBCDataSource =
KeepAliveTimerInterval = 0
BufferAccountingPackets = TRUE
MaximumBufferFileSize = "10 Megabytes"
NumberOfRetriesForBufferedPacket = 3
BackingStoreEnvironmentVariables =
UseLocalTimeZone = FALSE
AttributeList =
Delimiter =
SQLDefinition/
ODBCToRadiusMappings/
ODBCToEnvironmentMappings/
ODBCToCheckItemMappings/
```

Proxying Accounting Records

You can configure Cisco Prime AR to store accounting records locally and to proxy the accounting records to a remote RADIUS server thereby maintaining multiple accounting logs.

This section contains the following topics:

- [Configuring the Local Cisco Prime Access Registrar Server](#)
- [Configuring the RemoteServer Object](#)

Configuring the Local Cisco Prime Access Registrar Server

This type of setup requires you to configure the following on the local Cisco Prime AR server:

- A local accounting service of type file
- A remote accounting service of type radius
- An accounting service of type group
- A RemoteServer object

This section contained the following topics:

- [Configuring the Local Accounting Service](#)
- [Configuring the Remote Accounting Service](#)
- [Configuring the Group Accounting Service](#)

Configuring the Local Accounting Service

The following example shows the configuration required for a local accounting service. This service must be of type file.

```
[//localhost/Radius/Services/accserv1/ ]
  Name = accserv1
  Description =
  Type = file
  IncomingScript~ =
  OutgoingScript~ =
  OutagePolicy~ = RejectAll
  OutageScript~ =
  FilenamePrefix = accounting
  MaxFileSize = "10 Megabytes"
  MaxFileAge = "1 Day"
  RolloverSchedule =
  UseLocalTimeZone = FALSE
```

Configuring the Remote Accounting Service

The following example shows the configuration required for a remote accounting service. This service must be of type *radius*, and the name of the remote server must be listed under the RemoteServers subdirectory.

```
[//localhost/Radius/Services/accserv2/
  Name = accserv2
  Description =
  Type = radius
  IncomingScript~ =
  OutgoingScript~ =
  OutagePolicy~ = RejectAll
  OutageScript~ =
  MultipleServersPolicy = Failover
  RemoteServers/
    1. RemoteRADIUS
```

Configuring the Group Accounting Service

The following example shows the configuration required for a grouping accounting service. This service must be of type `group` and the local and remote accounting services, `accserv1` and `accserv2` in the previous examples, should be added under the `GroupServices` subdirectory.

The `CiscoAccounting` service groups these two services. The type property should be set to `group`. The services `accserv1` and `accserv2` should be added under `GroupServices` subdirectory of `CiscoAccounting` service.

```
[//localhost/Radius/Services/GroupAccounting/
  Name = GroupAccounting
  Description =
  Type = group
  IncomingScript~ =
  OutgoingScript~ =
  RolloverSchedule =
  ResultRule = AND
  GroupServices/
    1. accserv1
    2. accserv2
```

Refer to [Service Grouping Feature, page 17-14](#), for more information about the Cisco Prime AR Service Grouping feature.

Configuring the RemoteServer Object

The following example shows the configuration required for the `RemoteServer` object in the local Cisco Prime AR server.

```
[ //localhost/Radius/RemoteServers ]
  Entries 1 to 1 from 1 total entries
  Current filter: <all>

  RemoteRADIUS/
    Name = RemoteRADIUS
    Description =
    Protocol = radius
    IPAddress = aa.bb.cc.dd
    Port = 1645
    ReactivateTimerInterval = 300000
    SharedSecret = secret
    Vendor =
    IncomingScript~ =
    OutgoingScript~ =
    MaxTries = 3
    InitialTimeout = 2000
    AccountingPort = 1646
    ACKAccounting = TRUE
```

If the `ACKAccounting` property is set to `FALSE`, Cisco Prime AR disregards the accounting acknowledgement and continues with the packet processing rather than waiting for the accounting acknowledgement from the Remote server.

The group service, `CiscoAccounting` in this example, should be defined as the default accounting service for any accounting packets received by the local Cisco Prime AR server, as in the following:

```
set /Radius/DefaultAccountingService CiscoAccounting
```

Accounting Log Examples

This section provides examples of accounting log information recorded in an accounting log file. This section contains the following topics:

- [Accounting-Start Packet](#)
- [Accounting Stop Packet](#)
- [Trace of Successful Accounting](#)

Accounting-Start Packet

The Accounting-Start packet describes the type of service and the user attempting to login.

```
Tue, 06 Dec 2011 12:32:17.036
  User-Name = bob
  NAS-Port = 1
  Framed-IP-Address = 1.1.1.1
  Class = yahoo.com
  NAS-Identifier = localhost
  Acct-Status-Type = Start
  Acct-Session-Id = 1
```

Accounting Stop Packet

When the session ends, the NAS sends an Accounting Stop packet that describe the type of service that was delivered. The Accounting Stop packet might also contain statistics such as elapsed time, input and output octets, or input and output packets.

```
Tue, 06 Dec 2011 12:32:17.036
  User-Name = bob
  NAS-Port = 1
  Framed-IP-Address = 1.1.1.1
  Class = yahoo.com
  NAS-Identifier = localhost
  Acct-Status-Type = Stop
  Acct-Session-Id = S209524
```

Trace of Successful Accounting

The following is a trace example of a a successful accounting sequence.

```
11/12/2012 11/12/2012 21:27:58: P6699: Packet received from 10.1.9.204
11/12/2012 21:27:58: P6699: Trace of Accounting-Request packet
11/12/2012 21:27:58: P6699:   identifier = 127
11/12/2012 21:27:58: P6699:   length = 45
11/12/2012 21:27:58: P6699:   reqauth = ed:d6:a6:ae:57:09:b8:55:a8:d4:c4:0d:f7:be:06:2a
11/12/2012 21:27:58: P6699:   User-Name = bob
11/12/2012 21:27:58: P6699:   NAS-Identifier = localhost
11/12/2012 21:27:58: P6699:   Acct-Status-Type = Start
11/12/2012 21:27:58: P6699:   Acct-Session-Id = 1
11/12/2012 21:27:58: P6699: Using Client: cubone (10.1.9.204)
11/12/2012 21:27:58: P6699: Using NAS: localhost (127.0.0.1)
11/12/2012 21:27:58: P6699: Request is directly from a NAS: FALSE
```

```

11/12/2012 21:27:58: P6699: Running NAS localhost (127.0.0.1) IncomingScript: Pa seServiceHints
11/12/2012 21:27:58: P6699:      Rex: environ->get( "Request-Type" ) -> "Accounting-Request"
11/12/2012 21:27:58: P6699:      Rex: environ->get( "User-Name" ) -> ""
11/12/2012 21:27:58: P6699:      Rex: request->get( "User-Name", 0 ) -> "bob"
11/12/2012 21:27:58: P6699: Accounting with Service accserv1
11/12/2012 21:27:58: P6699: Trace of Accounting-Response packet
11/12/2012 21:27:58: P6699:      identifier = 127
11/12/2012 21:27:58: P6699:      length = 20
11/12/2012 21:27:58: P6699:      reqauth = a6:40:45:02:4c:8b:6f:00:4f:18:4a:b8:fe:28:9d:f4
11/12/2012 21:27:58: P6699: Sending response to 10.1.9.204

```

Sample Error Messages

The following are sample accounting error messages:

Error message logged in name_radius_1_log file when the disk is full and AR is trying to record an accounting request.

```

05/15/2012 2:52:29 name/radius/1 Error System 0 Failed to write records to the accounting
report file '/usr/accounting.log' - accounting records lost

```



Note

An Accounting-Response packet is sent only if the accounting record is written to the file in the disk. If the disk is full, an Accounting-Response packet is not sent.

Error message logged in name_radius_1_log file when the path specified in the FilenamePrefix property is not valid.

```

05/15/2012 4:11:12 name/radius/1 Error Configuration 0 Error in property
/Radius/Services/CiscoAccounting/FilenamePrefix: Unable to write to the specified report
file prefix (/tmp/AR/accounting)

```



CHAPTER 8

Diameter

Diameter is a networking protocol which is derived from RADIUS protocol. It is considered to be the next generation Authentication, Authorization, and Accounting (AAA) protocol. This is the other core protocol used in the IP Multimedia Subsystem (IMS) architecture for IMS Entities to exchange AAA related information. Cisco Prime AR supports Diameter Applications based on the Diameter Base Protocol defined in RFC 6733.

Diameter is composed of a base protocol and a set of applications which allows it to extend its services to new access technologies. The base protocol provides basic mechanisms for reliable transport, message delivery, and error handling. Each application is defined by an application identifier and associated with commands. Each command is defined with mandatory Attribute Value Pairs (AVPs) and non-mandatory AVPs including vendor-specific AVPs.

The base protocol must be used in conjunction with a Diameter application. Each application relies on the services of the base protocol to support a specific type of network access.

The following is the list of applications supported by Cisco Prime AR:

- Diameter Network Access Server Application (NASREQ, RFC 4005)
- Diameter Base Accounting (RFC 6733)

This chapter contains the following sections:

- [Before You Begin](#)
- [Diameter Server Startup Log](#)
- [Diameter Stack Level Messages](#)
- [Configuring Authentication and Authorization for Diameter](#)
- [Configuring Diameter Accounting](#)
- [Configuring the Diameter Application in Cisco Prime AR](#)
- [Writing Diameter Application in Cisco Prime AR](#)
- [Diameter Routing Agent](#)
- [Support for SCTP including Multihoming](#)

Before You Begin

Each Diameter application is identified by the unique application id and the set of commands associated with it and application specific AVPs. Cisco Prime AR requires addition of Diameter BaseApplication, NASREQApplication, and BaseAccounting Application to perform Diameter Authentication and Accounting.

To configure the BaseApplication, NASREQApplication, and BaseAccounting Application in Cisco Prime AR, follow the below steps in order from `/opt/CSCOAr/bin/` directory:

-
- Step 1** Execute the below command to import Diameter BaseApplication AVPs:
- ```
./aregcmd -s -f /cisco-ar/examples/cli/add-BaseProtocolAVPs.rc
```
- Step 2** Execute the below command to import Diameter BASEApplication:
- ```
./aregcmd -s -f /cisco-ar/examples/cli/add-BaseApplication.rc
```
- Step 3** Execute the below command to import Diameter NASREQApplication AVPs:
- ```
./aregcmd -s -f /cisco-ar/examples/cli/add-NASREQAVPs.rc
```
- Step 4** Execute the below command to import Diameter NASREQApplication:
- ```
./aregcmd -s -f /cisco-ar/examples/cli/add-NASREQApplication.rc
```
- Step 5** Execute the below command to import Diameter BaseAccounting application:
- ```
./aregcmd -s -f /cisco-ar/examples/cli/add-BaseAccountingApplication.rc
```

For registering NASREQApplication, configure `/Radius/Advanced/Diameter/General/AuthApplicationIdList` to 1.

For registering BaseAccounting, configure `/Radius/Advanced/Diameter/General/AcctApplicationIdList` to 3.

---

## Diameter Server Startup Log

When Cisco Prime AR starts, Diameter server also starts.

The log file shows the following:

```
09/30/2012 6:38:47.419 name/radius/1 Info Server 0 Diameter Server Started
09/30/2012 6:38:47.437 name/radius/1 Info Protocol 0 Starting diameter core
09/30/2012 6:38:47.447 name/radius/1 Info Protocol 0 Product : Cisco
Prime Access Registrar
09/30/2012 6:38:47.447 name/radius/1 Info Protocol 0 Version : 6
09/30/2012 6:38:47.447 name/radius/1 Info Protocol 0 Vendor Id : 0
09/30/2012 6:38:47.447 name/radius/1 Info Protocol 0 Auth Application : 0
09/30/2012 6:38:47.447 name/radius/1 Info Protocol 0 Auth Application : 1
09/30/2012 6:38:47.447 name/radius/1 Info Protocol 0 Acct Application : 3
09/30/2012 6:38:47.447 name/radius/1 Info Protocol 0 Dictionary :
/cisco-ar/conf/diadictionary.xml
09/30/2012 6:38:47.447 name/radius/1 Info Protocol 0 Identity :
10.81.79.43
09/30/2012 6:38:47.447 name/radius/1 Info Protocol 0 Realm : abc.com
09/30/2012 6:38:47.447 name/radius/1 Info Protocol 0 TCP Listen : 3868
09/30/2012 6:38:47.447 name/radius/1 Info Protocol 0 SCTP Listen : 3868
09/30/2012 6:38:47.447 name/radius/1 Info Protocol 0 Watch-Dog timeout : 500
09/30/2012 6:38:47.447 name/radius/1 Info Protocol 0 Use IPv6 : 0
```



```

09/30/2012 6:38:47.447 name/radius/1 Info Protocol 0 Re-transmission Int : 8
09/30/2012 6:38:47.447 name/radius/1 Info Protocol 0 Max Re-trans Int : 3
09/30/2012 6:38:47.447 name/radius/1 Info Protocol 0 Recv Buffer Size : 20480
09/30/2012 6:38:47.448 name/radius/1 Info Protocol 0 Hostnames Used :
10.81.79.43
09/30/2012 6:38:47.448 name/radius/1 Info Protocol 0 Dumping Peer Table
09/30/2012 6:38:47.448 name/radius/1 Info Protocol 0 Expire Time 1
09/30/2012 6:38:47.448 name/radius/1 Info Protocol 0 Peer : Host = 10.77.240.54,
Port = 3868, Server-Identity = , Server-Realm = , TLS = 0
09/30/2012 6:38:47.448 name/radius/1 Info Protocol 0 Peer : Host = 10.77.240.53,
Port = 3868, Server-Identity = , Server-Realm = , TLS = 0
09/30/2012 6:38:47.448 name/radius/1 Info Protocol 0 Dumping Route Table
09/30/2012 6:38:47.448 name/radius/1 Info Protocol 0 Exp Time : 0
09/30/2012 6:38:47.448 name/radius/1 Info Protocol 0 Route : Realm =
dia.com, Action = 2, Redirect-Usage = 0
09/30/2012 6:38:47.448 name/radius/1 Info Protocol 0
Application Id=1, Vendor=0
09/30/2012 6:38:47.449 name/radius/1 Info Protocol 0 Server
= 10.77.240.53, metric = 2
09/30/2012 6:38:47.449 name/radius/1 Info Protocol 0 Auth Stateful Auth : stateful
09/30/2012 6:38:47.449 name/radius/1 Info Protocol 0 Auth Session(T) : 30
09/30/2012 6:38:47.449 name/radius/1 Info Protocol 0 Auth Lifetime(T) : 360
09/30/2012 6:38:47.449 name/radius/1 Info Protocol 0 Auth Grace(T) : 30
09/30/2012 6:38:47.450 name/radius/1 Info Protocol 0 Auth Abort(T) : 20
09/30/2012 6:38:47.450 name/radius/1 Info Protocol 0 Acct Session(T) : 30
09/30/2012 6:38:47.450 name/radius/1 Info Protocol 0 Acct Interim Int : 5
09/30/2012 6:38:47.450 name/radius/1 Info Protocol 0 Acct Real-Time : 0
09/30/2012 6:38:47.450 name/radius/1 Info Protocol 0 Debug Log : enabled
09/30/2012 6:38:47.450 name/radius/1 Info Protocol 0 Trace Log : enabled
09/30/2012 6:38:47.450 name/radius/1 Info Protocol 0 Info Log : enabled
09/30/2012 6:38:47.450 name/radius/1 Info Protocol 0 Console Log : enabled
09/30/2012 6:38:47.450 name/radius/1 Info Protocol 0 Syslog Log : disabled

```

## Diameter Stack Level Messages

The following are the stack level messages that are exchanged between the diameter peers:

- [Capabilities Exchange Message](#)
- [Watchdog Message](#)

## Capabilities Exchange Message

When Diameter peers establish a transport connection to Cisco Prime AR, they will exchange the Capabilities Exchange messages. This message allows the discovery of a peer's identity and its capabilities (protocol version number, supported Diameter applications, security mechanisms, etc.)

The log file shows the following:

```

09/30/2012 6:38:57.525 name/radius/1 Info Protocol 0 Peer Capabilities
09/30/2012 6:38:57.525 name/radius/1 Info Protocol 0 Hostname :
10.77.240.54
09/30/2012 6:38:57.525 name/radius/1 Info Protocol 0 Realm : cisco.in
09/30/2012 6:38:57.525 name/radius/1 Info Protocol 0 Host IP : type=1,
10.77.240.150
09/30/2012 6:38:57.525 name/radius/1 Info Protocol 0 VendorId : 11
09/30/2012 6:38:57.525 name/radius/1 Info Protocol 0 Product Name : Cisco
Prime Access Registrar

```

```

09/30/2012 6:38:57.525 name/radius/1 Info Protocol 0 Orig State :
1094807040
09/30/2012 6:38:57.525 name/radius/1 Info Protocol 0 Auth Application Id : 1
09/30/2012 6:38:57.525 name/radius/1 Info Protocol 0 Acct Application Id : 3
09/30/2012 6:38:57.525 name/radius/1 Info Protocol 0 Inband Sec : 0
09/30/2012 6:38:57.525 name/radius/1 Info Protocol 0 Firmware Ver : 1
09/30/2012 6:38:57.526 name/radius/1 Info Protocol 0 Statistics for the peer
10.77.240.54 is sent with code value 505
09/30/2012 6:38:57.526 name/radius/1 Info Protocol 0 Statistics for the peer
10.77.240.54 is sent with code value 508

```

## Watchdog Message

The Device-Watchdog-Request and Device-Watchdog-Answer messages are used to proactively detect transport failures. Device Watchdog message time interval is configurable in Cisco Prime AR.

The log file shows the following:

```

10/07/2012 10:44:15.143: Log: Watchdog msg from [thomas.cisco.com.cisco1.com],
state=1254936955, time=1254937455.

```

## Terminating Diameter User Session

In Cisco Prime AR, Diameter Session management is independent of Diameter accounting. Session termination is conveyed by a specific Session-Termination message rather than an Accounting Stop message.

The log file shows the following:

```

10/07/2012 10:37:39.299: Log: *** Session termination request received ***
10/07/2012 10:37:39.299: Log: Session id=thomas.cisco.com.cisco1.com;(;H;
10/07/2012 10:37:39.299: Log: From Host: thomas.cisco.com
10/07/2012 10:37:39.299: Log: From Realm: cisco1.com
10/07/2012 10:37:39.299: Log: From User: invaliduser
10/07/2012 10:37:39.299: Log: Termination Cause: 5003
10/07/2012 10:37:39.299: Log: Auth Application Id: 1
10/07/2012 10:37:39.300: Log: Session disconnect for Session-Id:
thomas.cisco.com.cisco1.com;1254936955;124122

```



### Note

In Cisco Prime AR, session management does not support Diameter messages. Diameter base stack (RFC 6733) will maintain the session.

## Configuring Authentication and Authorization for Diameter

This section describes how to configure Cisco Prime AR to perform authentication and authorization and how to configure a local service and userlist.

See [Table 4-7](#) for more information on Diameter client properties.

This section contains the following topics:

- [Configuring Local Authentication and Authorization](#)
- [Configuring External Authentication Service](#)

## Configuring Local Authentication and Authorization

In Diameter, an AA-Request packet is a request for authentication and authorization. Authentication checks username and password credentials, while authorization typically involves returning the correct information to allow the service a user is authorized to have. Cisco Prime AR performs AA and returns the appropriate Diameter attributes in an AA-Answer packet.

For adding a Diameter peer in Cisco Prime AR, configure a new entry in the clients (including Policy and Charging Rules Functions (PCRF), Home Subscriber Servers (HSS), Mobility Management Entities (MME), Online Charging Systems (OCS), and others) and remote server object.

The following shows an example configuration for adding a Diameter peer (NAS/Client) in Cisco Prime AR.

```
Name = diameter-client
Description =
Protocol = diameter
HostName = 10.81.79.42
 Vendor =
IncomingScript~ =
OutgoingScript~ =
Port = 3868
SCTP-Enabled = FALSE

[//localhost/Radius/Services/dia-local]
Name = dia-local
Description =
Type = diameter
Realm = abc.com
Role = Local
AuthenticationService = local-users
AccountingService = local-file
Peers/

DefaultAuthenticationService~ = dia-local
DefaultAuthorizationService~ = dia-local
```



### Note

You should restart the Cisco Prime AR server if you change any Diameter specific configuration.

See [Table 4-7](#) and [Table 4-21](#) for more details.

## Configuring a Local Service and UserList

See “[Configuring a Local Service and UserList](#)” section on page 6-1 for more information on how to configure a local service and user list.

The following messages are logged in the trace file at the time of authenticating a valid user:

```
06/03/2012 7:26:00.138: P195: Diameter Packet received from 10.81.79.42
06/03/2012 7:26:00.139: P195: Trace of Diameter-Access-Request packet
06/03/2012 7:26:00.139: P195: Session-Id = .;1096298391;16
06/03/2012 7:26:00.139: P195: Auth-Application-Id = 1
06/03/2012 7:26:00.139: P195: Origin-Host = 10.81.79.42
06/03/2012 7:26:00.139: P195: Origin-Realm = abc1.com
06/03/2012 7:26:00.139: P195: Destination-Realm = abc.com
06/03/2012 7:26:00.139: P195: Auth-Request-Type = 3
06/03/2012 7:26:00.139: P195: User-Name = bob
06/03/2012 7:26:00.139: P195: Using Client: murdoch
06/03/2012 7:26:00.139: P195: Authenticating and Authorizing with Service dia-local
```

```

06/03/2012 7:26:00.139: P195: Calling Service local-users for authentication and
authorization
06/03/2012 7:26:00.139: P195: Getting User bob's UserRecord from UserList Default
06/03/2012 7:26:00.140: P195: user list user bob's password matches
06/03/2012 7:26:00.140: P195: Trace of Diameter-Access-Accept
06/03/2012 7:26:00.140: P195: Auth-Application-Id = 1
06/03/2012 7:26:00.140: P195: User-Name = bob
06/03/2012 7:26:00.140: P195: Auth-Request-Type = 3
06/03/2012 7:26:00.140: P195: Result-Code = 2001

```

The following messages are logged in the trace file at the time of authenticating an invalid user:

```

10/02/2012 22:54:58.512: P74: Diameter Packet received from 10.81.79.42
10/02/2012 22:54:58.512: P74: Trace of Diameter-Access-Request packet
10/02/2012 22:54:58.512: P74: Session-Id = .;1096298391;1
10/02/2012 22:54:58.512: P74: Auth-Application-Id = 1
10/02/2012 22:54:58.512: P74: Auth-Request-Type = 3
10/02/2012 22:54:58.512: P74: Destination-Realm = abc.com
10/02/2012 22:54:58.512: P74: Origin-Host = 10.81.79.42
10/02/2012 22:54:58.512: P74: Origin-Realm = abc1.com
10/02/2012 22:54:58.512: P74: User-Name = james
10/02/2012 22:54:58.512: P74: Tracing the packet after running the rules and policies
10/02/2012 22:54:58.512: P74: Trace of Diameter-Access-Request packet
10/02/2012 22:54:58.512: P74: Session-Id = .;1096298391;1
10/02/2012 22:54:58.512: P74: Auth-Application-Id = 1
10/02/2012 22:54:58.512: P74: Auth-Request-Type = 3
10/02/2012 22:54:58.512: P74: Destination-Realm = abc.com
10/02/2012 22:54:58.512: P74: Origin-Host = 10.81.79.42
10/02/2012 22:54:58.512: P74: Origin-Realm = abc1.com
10/02/2012 22:54:58.512: P74: User-Name = james
10/02/2012 22:54:58.512: P74: Using Client: murdoch
10/02/2012 22:54:58.512: P74: Authenticating and Authorizing with Service dia-local
10/02/2012 22:54:58.512: P74: Calling Service local-users for authentication and
authorization
10/02/2012 22:54:58.512: P74: Getting User jame's UserRecord from UserList Default
10/02/2012 22:54:58.513: P74: Failed to get User jame's UserRecord from UserList
Default
10/02/2012 22:54:58.513: P74: Trace of Diameter-Access-Reject
10/02/2012 22:54:58.513: P74: Auth-Application-Id = 1
10/02/2012 22:54:58.513: P74: User-Name = james
10/02/2012 22:54:58.513: P74: Auth-Request-Type = 3
10/02/2012 22:54:58.513: P74: Result-Code = 4001

```

## Configuring External Authentication Service

See [Table 4-17](#) for more information on how to configure external authentication service.

## Configuring Diameter Accounting

This section describes Diameter Accounting in Cisco Prime AR as defined in Internet RFC 6733. This section explains the following:

- [Understanding Diameter Accounting](#)
- [Setting Up Local Accounting](#)
- [Diameter Accounting Log Examples](#)

## Understanding Diameter Accounting

Diameter Accounting is the process of collecting and storing the information contained in Accounting-Event, Accounting-Start, and Accounting-Interim and Accounting-Stop messages. Internet RFC 6733 describes the protocol for sending accounting information between a Network Access Server (NAS) and a DIAMETER server.

**Note**

Cisco Prime AR uses TCP port number 3868 as its default port for Diameter accounting messages. Accounting/Authentication port number is configurable in Cisco Prime AR.

## Setting Up Local Accounting

See [Chapter 7, “Setting Up Accounting”](#) for more information.

## Setting up Oracle Accounting

See [Chapter 7, “Oracle Accounting”](#) for more information.

## Diameter Accounting Log Examples

This section provides examples of Diameter accounting information recorded in an accounting log file.

### Accounting Event Packet

```
Tue, 20 Oct 2012 15:27:18.340
 Session-Id = thomas.cisco.com.cisco1.com;1256052431;900083
 Origin-Host = thomas.cisco.com
 Origin-Realm = cisco1.com
 Destination-Realm = cisco.com
 Accounting-Record-Type = 1
 Accounting-Record-Number = 1
 Acct-Application-Id = 3
 Accounting-Sub-Session-Id = 1
 Acct-Interim-Interval = 5
 Accounting-Realtime-Required = 0
 Origin-State-Id = 1256052431
```

### Accounting Start Packet

```
Tue, 20 Oct 2012 15:49:57.086
 Session-Id = thomas.cisco.com.cisco1.com;1256053789;847161
 Origin-Host = thomas.cisco.com
 Origin-Realm = cisco1.com
 Destination-Realm = cisco.com
 Accounting-Record-Type = 2
 Accounting-Record-Number = 1
 Acct-Application-Id = 3
 Accounting-Sub-Session-Id = 1
 Acct-Interim-Interval = 5
 Accounting-Realtime-Required = 0
```

```
Origin-State-Id = 1256053789
```

## Account Interim Packet

```
Tue, 20 Oct 2012 15:50:12.338
Session-Id = thomas.cisco.com.cisco1.com;1256053789;847161
Origin-Host = thomas.cisco.com
Origin-Realm = cisco1.com
Destination-Realm = cisco.com
Accounting-Record-Type = 3
Accounting-Record-Number = 4
Acct-Application-Id = 3
Accounting-Sub-Session-Id = 1
Acct-Interim-Interval = 5
Accounting-Realtime-Required = 1
Origin-State-Id = 1256053789
```

## Accounting Stop Packet

```
Tue, 20 Oct 2012 15:50:18.116
Session-Id = thomas.cisco.com.cisco1.com;1256053789;847161
Origin-Host = thomas.cisco.com
Origin-Realm = cisco1.com
Destination-Realm = cisco.com
Accounting-Record-Type = 4
Accounting-Record-Number = 6
Acct-Application-Id = 3
Accounting-Sub-Session-Id = 1
Acct-Interim-Interval = 5
Accounting-Realtime-Required = 1
Origin-State-Id = 1256053789
```

## Trace of Successful Accounting

The following is a trace example of a successful accounting sequence:

```
10/02/2012 12:05:03.146: P161: Trace of Diameter-Accounting-Request packet
10/02/2012 12:05:03.146: P161: Session-Id =
10.81.79.42.cisco5.com;1317577008;898336
10/02/2012 12:05:03.146: P161: Accounting-Record-Number = 1
10/02/2012 12:05:03.146: P161: Accounting-Record-Type = 2
10/02/2012 12:05:03.146: P161: Destination-Realm = abc.com
10/02/2012 12:05:03.146: P161: Origin-Host = 10.81.79.42
10/02/2012 12:05:03.146: P161: Origin-Realm = cisco5.com
10/02/2012 12:05:03.146: P161: Accounting-Realtime-Required = 0
10/02/2012 12:05:03.146: P161: Accounting-Sub-Session-Id = 1
10/02/2012 12:05:03.146: P161: Acct-Application-Id = 3
10/02/2012 12:05:03.146: P161: Acct-Interim-Interval = 5
10/02/2012 12:05:03.146: P161: Origin-State-Id = 1317577008
10/02/2012 12:05:03.146: P161: Tracing the packet after running the rules and policies
10/02/2012 12:05:03.146: P161: Trace of Diameter-Accounting-Request packet
10/02/2012 12:05:03.146: P161: Session-Id =
10.81.79.42.cisco5.com;1317577008;898336
10/02/2012 12:05:03.146: P161: Accounting-Record-Number = 1
10/02/2012 12:05:03.146: P161: Accounting-Record-Type = 2
10/02/2012 12:05:03.146: P161: Destination-Realm = abc.com
10/02/2012 12:05:03.147: P161: Origin-Host = 10.81.79.42
10/02/2012 12:05:03.147: P161: Origin-Realm = cisco5.com
10/02/2012 12:05:03.147: P161: Accounting-Realtime-Required = 0
```

```

10/02/2012 12:05:03.147: P161: Accounting-Sub-Session-Id = 1
10/02/2012 12:05:03.147: P161: Acct-Application-Id = 3
10/02/2012 12:05:03.147: P161: Acct-Interim-Interval = 5
10/02/2012 12:05:03.147: P161: Origin-State-Id = 1317577008
10/02/2012 12:05:03.147: P161: Using Client: murdoch
10/02/2012 12:05:03.147: P161: Accounting with Service dia-local
10/02/2012 12:05:03.147: P161: Calling Service local-file for accounting
10/02/2012 12:05:03.123: P161: Trace of Diameter-Accounting-Response packet
10/02/2012 12:05:03.123: P161: Session-Id =
10.81.79.42.cisco5.com;1317577008;898336
10/02/2012 12:05:03.123: P161: Result-Code = 2001
10/02/2012 12:05:03.123: P161: Origin-Host = 10.77.247.117
10/02/2012 12:05:03.123: P161: Origin-Realm = abc.com
10/02/2012 12:05:03.123: P161: Accounting-Record-Type = 2
10/02/2012 12:05:03.123: P161: Accounting-Record-Number = 1
10/02/2012 12:05:03.123: P161: Acct-Application-Id = 3
10/02/2012 12:05:03.123: P161: Accounting-Sub-Session-Id = 1
10/02/2012 12:05:03.123: P161: Error-Reporting-Host = 10.77.247.117
10/02/2012 12:05:03.123: P161: Accounting-Realtime-Required = 1
10/02/2012 12:05:03.123: P161: Acct-Interim-Interval = 5
10/02/2012 12:05:03.123: P161: Origin-State-Id = 1317576779

```

## Configuring the Diameter Application in Cisco Prime AR

For proxying a diameter application message in Cisco Prime AR, ensure that you do the following:

- [Importing Application Specific Cisco AVPs to Cisco Prime AR Internal Database](#)
- [Configuring the Transport Management Properties](#)
- [Registering Applications IDs](#)
- [Configuring the Diameter Peers](#)
- [Configure the Diameter Service](#)

## Importing Application Specific Cisco AVPs to Cisco Prime AR Internal Database

You need to import the diameter application specific command codes and AVPs to the Cisco Prime AR internal database. The following is an example for importing Gy application command codes and AVPs. Ensure that you execute the following commands in the specified order to import the Diameter AVPs for BASE, NASREQ, and Gy applications.

```

/cisco-ar/bin/aregcmd -s -f /cisco-ar/examples/cli/add-BaseProtocolAVPs.rc
/cisco-ar/bin/aregcmd -s -f /cisco-ar/examples/cli/add-BaseApplication.rc
/cisco-ar/bin/aregcmd -s -f /cisco-ar/examples/cli/add-NASREQAVPs.rc
/cisco-ar/bin/aregcmd -s -f /cisco-ar/examples/cli/add-NASREQApplication.rc
/cisco-ar/bin/aregcmd -s -f /cisco-ar/examples/cli/add-BaseAccountingApplication.rc
/cisco-ar/bin/aregcmd -s -f /cisco-ar/examples/cli/Common-Gx-Gxx-Gy-Rx-S9.rc
/cisco-ar/bin/aregcmd -s -f /cisco-ar/examples/cli/Common-Gx-Gy-Gxx-S9-S6-Rx.rc
/cisco-ar/bin/aregcmd -s -f /cisco-ar/examples/cli/Common-Cx-Gx-S9-Gy.rc
/cisco-ar/bin/aregcmd -s -f /cisco-ar/examples/cli/Common-Cx-Wx-Sh-Gy.rc
/cisco-ar/bin/aregcmd -s -f /cisco-ar/examples/cli/Common-Gx-Gxx-S9-Gy.rc
/cisco-ar/bin/aregcmd -s -f /cisco-ar/examples/cli/Common-Gx-Rx-Gy-S9.rc
/cisco-ar/bin/aregcmd -s -f /cisco-ar/examples/cli/Common-Gxx-S9-Gy.rc
/cisco-ar/bin/aregcmd -s -f /cisco-ar/examples/cli/Common-Gy-Cx-Sh.rc
/cisco-ar/bin/aregcmd -s -f /cisco-ar/examples/cli/Common-Gy-Gx-S9.rc

```

```

/cisco-ar/bin/aregcmd -s -f /cisco-ar/examples/cli/Common-Gy-S6.rc
/cisco-ar/bin/aregcmd -s -f /cisco-ar/examples/cli/Common-Gy-S6-Sh.rc
/cisco-ar/bin/aregcmd -s -f
/cisco-ar/examples/cli/add-CreditControl-Gy-ApplicationAVPs.rc
/cisco-ar/bin/aregcmd -s -f /cisco-ar/examples/cli/add-CreditControl-Gy-Application.rc

Server 'Radius' is Running, its health is 10 out of 10

```

## Configuring the Transport Management Properties

You need to log into the aregcmd using the CLI interface and configure the Transport Management properties in the **Radius/Advanced/Diameter/**.

```

/opt/CSCOar/bin/./aregcmd -s
Cisco Prime Access Registrar Configuration Utility
Copyright (C) 1995-2012 by Cisco Systems, Inc. All rights reserved. Logging in to
localhost
[//localhost]
LicenseInfo = AR-DRN-2000TPS 5.1(2000TPS:expires on 1-Feb-2012) Radius/
Administrators/
Server 'Radius' is Running, its health is 10 out of 10
--> cd Radius/Advanced/Diameter/
--> cd TransportManagement/
[//localhost/Radius/Advanced/Diameter/TransportManagement]
Identity =
Realm =
TCPListenPort = 3868
SCTPListenPort = 3868
EnableIPv6 = FALSE
WatchdogTimeout = 500
ReconnectInterval = 500
MaxReconnections = 3
RequestRetransmissionInterval = 100
MaxRequestRetransmissionCount = 3
ReceiveBufferSize = 2048
AdvertisedHostName/

```

You need to set the Identity and AdvertisedHostName properties to IP Address or hostname of the machine in which Cisco Prime AR is installed.

```

--> set Identity 10.77.240.69
Set Identity 10.77.240.69

--> cd AdvertisedHostName
set 1 10.77.240.69
Set 1 10.77.240.69
Set the Realm in which Cisco Prime Access Registrar server is present.
--> set Realm cisco.com
Set Realm cisco.com

Save the configuration

--> save

Validating //localhost...
Saving //localhost...

ls
Identity = 10.77.240.69
Realm = cisco.com

```



```

TCPListenPort = 3868
SCTPListenPort = 3868
EnableIPv6 = FALSE
WatchdogTimeout = 500
ReconnectInterval = 500
MaxReconnections = 3
RequestRetransmissionInterval = 100
MaxRequestRetransmissionCount = 3
ReceiveBufferSize = 2048
AdvertisedHostName/
1. 10.77.240.69

```

The description for these properties is available at:

[http://www.cisco.com/en/US/docs/net\\_mgmt/access\\_registrar/5.1/user/guide/objects.html#wp1145662](http://www.cisco.com/en/US/docs/net_mgmt/access_registrar/5.1/user/guide/objects.html#wp1145662)



#### Note

Cisco Prime AR can only listen to one port for diameter connections. In the above configuration, the port number is 3868. All of the diameter clients must use this port number to communicate with the Cisco Prime AR.

## Registering Applications IDs

You need to register the applications IDs for which Cisco Prime AR needs to route the Diameter Messages.

### Registering the Gy application to a diameter stack

To register the Gy application to a diameter stack,

**Step 1** Move to the `//localhost/Radius/Advanced/Diameter/General` directory.

```

[//localhost/Radius/Advanced/Diameter]
IsDiameterEnabled = TRUE
General/
TransportManagement/
SessionManagement/
Applications/
Commands/
Diameter Dictionary/

--> cd General/

[//localhost/Radius/Advanced/Diameter/General]
Product = Cisco Prime Access Registrar
Version = 6.0
AuthApplicationIdList =
AcctApplicationIdList =

```

The description for these properties is available at

[http://www.cisco.com/en/US/docs/net\\_mgmt/access\\_registrar/6.0/user/guide/objects.html#wp1145646](http://www.cisco.com/en/US/docs/net_mgmt/access_registrar/6.0/user/guide/objects.html#wp1145646)

**Step 2** Set the `AuthApplicationIdList` to list of colon separated values of Application Ids.

```

--> set AuthApplicationIdList "4"

Set AuthApplicationIdList 4

```

## Configuring the Diameter Peers

You need to configure the Diameter Peers such as clients and servers in the **/Radius/Clients** directory. The following is an example for configuring the Diameter Peers such as GGSN and OCS:

```

ggsn/
 Name = ggsn
 Description =
 Protocol = diameter
 HostName = GGSN-Gy
 Vendor =
 IncomingScript~ =
 OutgoingScript~ =
 Port = 3868
 SCTP-Enabled = FALSE
 Server-Identity =
 Server-Realm =

ocs/
 Name = ocs
 Description =
 Protocol = diameter
 HostName = 192.168.30.88
 Vendor =
 IncomingScript~ =
 OutgoingScript~ =
 Port = 50301
 SCTP-Enabled = FALSE
 Server-Identity =
 Server-Realm =

ocs1/
 Name = ocs1
 Description =
 Protocol = diameter
 HostName = 192.168.30.86
 Vendor =
 IncomingScript~ =
 OutgoingScript~ =
 Port = 60301
 SCTP-Enabled = FALSE
 Server-Identity =
 Server-Realm =

```

The description for these properties is available at:

[http://www.cisco.com/en/US/docs/net\\_mgmt/access\\_registrar/6.0/user/guide/objects.html#wp1145646](http://www.cisco.com/en/US/docs/net_mgmt/access_registrar/6.0/user/guide/objects.html#wp1145646)



### Note

In order to resolve the hostnames and get the IP addresses, the Cisco Prime AR should either be configured with a DNS server IP, or the client's hostnames and IP addresses should be included in the `/etc/hosts` file.

```

Do not remove the following line, or various programs
that require network functionality will fail.
127.0.0.1 Cisco Prime AR localhost.localdomain localhost
172.16.29.7 GGSN-Gy
::1 localhost6.localdomain6 localhost6

```

## Configure the Diameter Service

To configure the Diameter Service to route the Diameter Messages based on the Realm,

**Step 1** Add a Service of type diameter in /Radius/Services/.

```
--> cd /Radius/Services/
--> add dia-proxy

Added dia-proxy

--> cd dia-proxy

[//localhost/Radius/Services/dia-proxy]
 Name = dia-proxy
 Description =
 Type =
--> set Type diameter

Set Type diameter
```

**Step 2** Set role as Proxy and realm to which Cisco Prime AR needs to route the diameter messages.

```
--> ls

[//localhost/Radius/Services/dia-proxy]
 Name = dia-proxy
 Description =
 Type = diameter
 Realm = abc.com
 Role = Local
 IncomingScript~ =
 OutgoingScript~ =
 AuthenticationService =
 AccountingService =
 Peers/

Set the Role as proxy
--> set Role Proxy

Set Role Proxy

--> set Realm mcprealm.com

Set Realm mcprealm.com
```

**Step 3** Add a Gy application.

```
--> ls

[//localhost/Radius/Services/dia-proxy]
 Name = dia-proxy
 Description =
 Type = diameter
 Realm = mcprealm.com
 Role = Proxy
 IncomingScript~ =
 OutgoingScript~ =
 Applications/

--> cd Applications/
```

```
[//localhost/Radius/Services/dia-proxy/Applications]
 Entries 0 to 0 from 0 total entries
 Current filter: <all>

--> add Gy

Added Gy

--> cd Gy/

[//localhost/Radius/Services/dia-proxy/Applications/Gy]
 Name = Gy
 Description =
 ApplicationID =
 DeMultiplexCCTerminateRequest = FALSE
 EnableSticky = FALSE
 MultiplePeersPolicy = Failover
 Peers/
```

**Step 4** Set the application ID as 4 for Gy application and configure the sticky properties.

```
--> set ApplicationID 4

Set ApplicationID 4

--> set EnableSticky TRUE

Set EnableSticky TRUE

--> ls

[//localhost/Radius/Services/dia-proxy/Applications/Gy]
 Name = Gy
 Description =
 ApplicationID = 4
 DeMultiplexCCTerminateRequest = FALSE
 EnableSticky = TRUE
 StickySessionKey =
 StickyCreationCmdList =
 StickyDeletionCmdList =
 MultiplePeersPolicy = Failover
 Peers/

--> set StickySessionKey Session-Id#1

Set StickySessionKey Session-Id#1

--> set StickyCreationCmdList 272

Set StickyCreationCmdList 272

--> set StickyDeletionCmdList 272::CC-Request-Type=3

Set StickyDeletionCmdList 272::CC-Request-Type=3

--> set MultiplePeersPolicy RoundRobin

Set MultiplePeersPolicy RoundRobin

--> ls

[//localhost/Radius/Services/dia-proxy/Applications/Gy]
 Name = Gy
```

```

Description =
ApplicationID = 4
DeMultiplexCCTerminateRequest = FALSE
EnableSticky = TRUE
StickySessionKey = Session-Id#1
StickyCreationCmdList = 272
StickyDeletionCmdList = 272::CC-Request-Type=3
MultiplePeersPolicy = RoundRobin
Peers/

```

**Step 5** Add the OCS peers to which Cisco Prime AR needs to load balance the diameter Gy messages matching the Destination-Realm mcprealm.com.

```

--> cd Peers/

[//localhost/Radius/Services/dia-proxy/Applications/Gy/Peers]
 Entries 0 to 0 from 0 total entries
 Current filter: <all>

--> add ocs1

Added ocs1

--> cd ocs1/

[//localhost/Radius/Services/dia-proxy/Applications/Gy/Peers/ocs1]
 Name = ocs1
 HostName =
 Metric = 2
 Weight = 0
 IMSIRanges =

--> set HostName 192.168.30.88

Set HostName 192.168.30.88

--> cd ..

[//localhost/Radius/Services/dia-proxy/Applications/Gy/Peers]
 Entries 1 to 1 from 1 total entries
 Current filter: <all>

 ocs1/

--> add ocs2

Added ocs2

--> cd ocs2/

[//localhost/Radius/Services/dia-proxy/Applications/Gy/Peers/ocs2]
 Name = ocs2
 HostName =
 Metric = 2
 Weight = 0
 IMSIRanges =

--> set HostName 192.168.30.86

Set HostName 192.168.30.86

```

**Step 6** Save the configuration details.

```
--> save
Validating //localhost...
Saving //localhost...
```

**Step 7** Set DefaultAuthenticationService and DefaultAuthorizationService in /Radius directory.

```
--> set DefaultAuthenticationService dia-proxy

Set DefaultAuthenticationService dia-proxy

--> set DefaultAuthorizationService dia-proxy

Set DefaultAuthorizationService dia-proxy

--> save
Validating //localhost...
Saving //localhost...

--> exit

--> exit
Logging out of localhost...
```

**Step 8** Restart the Cisco Prime AR server.

```
/cisco-ar/bin/arserver restart
```

---

The following illustrates the diameter proxy service configuration for Gy application which load balances the diameter Gy (App ID =4) messages to the remote peers ocs1(192.168.30.88) and ocs2(192.168.30.86).

```
[//localhost/Radius/Services/dia-proxy]
 Name = dia-proxy
 Description =
 Type = diameter
 Realm = mcprealm.com
 Role = proxy
 IncomingScript~ =
 OutgoingScript~ =
 Applications/
 Entries 1 to 1 from 1 total entries
 Current filter: <all>

 Gy/
 Name = Gy
 Description =
 ApplicationID = 4
 DeMultiplexCCTerminateRequest = FALSE
 EnableSticky = TRUE
 StickySessionKey = Session-Id#1
 StickyCreationCmdList = 272
 StickyDeletionCmdList = 272::CC-Request-Type=3
 MultiplePeersPolicy = RoundRobin
 Peers/
 Entries 1 to 2 from 2 total entries
 Current filter: <all>

 ocs1/
 Name = ocs
 HostName = 192.168.30.88
 Metric = 2
 Weight = 0
 IMSIRanges =
```

```

ocs2/
 Name = ocs2
 HostName = 192.168.30.86
 Metric = 3
 Weight = 0
 IMSIRanges =

```

The description for these properties is available at :

[http://www.cisco.com/en/US/docs/net\\_mgmt/access\\_registrar/6.0/user/guide/objects.html#wp1145646](http://www.cisco.com/en/US/docs/net_mgmt/access_registrar/6.0/user/guide/objects.html#wp1145646)

## Writing Diameter Application in Cisco Prime AR

Cisco Prime AR supports extensibility by allowing users to create new:

- authentication/authorization applications
- accounting applications
- command codes
- AVP's

This section contains the following topics:

- [Configuring rex script/service for Diameter](#)
- [Scripting in Diameter](#)
- [Diameter Environment Variables](#)
- [Sample rex script/service](#)
- [Traces/Logs](#)

## Configuring rex script/service for Diameter

To configure script/service for diameter using aregcmd:

- Step 1** Add application specific AVPs in **//localhost/Radius/Advanced/Diameter/Diameter Dictionary** other than Base stack AVPs.

```

[//localhost/Radius/Advanced/Diameter/Diameter Dictionary/CiscoAVPS]
 Name = CiscoAVPS
 Description =
 IsVendorSpecific = FALSE
 ApplicationID =
 AVPs/

```

- Step 2** Add a new command in **//localhost/Radius/Advanced/Diameter/Commands/** and specify the Request and Answers messages rules.

```

[//localhost/Radius/Advanced/Diameter/Commands/CiscoCmd]
 Name = CiscoCmd
 Description =
 CommandCode = 402
 EnableProxyBit = FALSE
 RequestMsgAVPs/
 AnswerMsgAVPs/

```

- Step 3** Add a new application in `//localhost/Radius/Advanced/Diameter/Applications/` and specify the commands used by the application.

```
[//localhost/Radius/Advanced/Diameter/Applications/Ciscoapp]
 Name = Ciscoapp
 Description =
 IsAuthApplication = TRUE
 IsVendorSpecific = FALSE
 ApplicationID = 12
 ApplicationURI =
 Commands/
```

- Step 4** Write a rex script (C/C++) and add it in the scripting point or rex service.

```
[//localhost/Radius/Services/diaservice]
 Name = diaservice
 Description =
 Type = rex
 IncomingScript~ =
 OutgoingScript~ =
 OutagePolicy~ = RejectAll
 OutageScript~ =
 Filename = librexscript.so
 EntryPoint = DiaService
 InitEntryPoint =
 InitEntryPointArgs =
```

Refer [Sample rex script/service, page 8-19](#).

## Scripting in Diameter

Cisco Prime AR supports 'rex' scripts for Diameter protocol. The script can be configured only as the server incoming script. The commands available for scripting are restricted to 'get' and 'put' on the dictionaries. While setting a value to an attribute, the following convention needs to be followed "<type number>,<value>". For example, if a 'Class' attribute needs to be added to the response dictionary with value as "classvalue", then set it as follows in the script:

**pResponse->put( pResponse, "Class", "1,classvalue", REX\_REPLACE );**

The following is the list of supported scripting types with the respective type numbers:

```
AVP_STRING_TYPE = 1
AVP_ADDRESS_TYPE = 2
AVP_INTEGER32_TYPE = 3
AVP_UINT32_TYPE = 4
AVP_UTF8_STRING_TYPE = 6
AVP_ENUM_TYPE = 7
AVP_TIME_TYPE = 11
```

Setting response attributes via a script is the only mechanism to add authorization attributes for Diameter requests.

## Diameter Environment Variables

This section lists the environment variables that you can use in scripts for Diameter messages.



Table 8-1 lists the Diameter Environment variables and descriptions.

**Table 8-1 Diameter Environment Variables**

| Variable                | Description                                                                                                                                                                                                                                                                                         |
|-------------------------|-----------------------------------------------------------------------------------------------------------------------------------------------------------------------------------------------------------------------------------------------------------------------------------------------------|
| Request-Type            | String value.                                                                                                                                                                                                                                                                                       |
| Response-Type           | Get/Set the request and response type for diameter packet.<br><b>Sample Values</b><br>Diameter-Access-Request<br>Diameter-Access-Accept<br>Diameter-Access-Reject<br>Diameter-Accounting-Request<br>Diameter-Accounting-Response<br>Diameter-Proxy-Request<br>Diameter-Proxy-Answer                 |
| Diameter-Application-Id | String value.<br>Get the application id for the packet. For setting in response, need to use Auth-Application-id or Acct-Application-id AVPs.<br>In Accounting type packet, use Acct-Application-Id AVP to get the application id.<br><b>Sample Values</b><br>1 ( NASREQ )<br>3 ( Base Accounting ) |
| Diameter-Command-Code   | String value.<br>Get command code for the diameter packet. It will work only for the access-request packet, not for the accounting request.<br><b>Sample Values</b><br>265 ( AA-Request )                                                                                                           |

## Sample rex script/service

```
int REXAPI DiaService(int iScriptingPoint,
 rex_AttributeDictionary_t* pRequest,
 rex_AttributeDictionary_t* pResponse,
 rex_EnvironmentDictionary_t* pEnviron)
{
 if(iScriptingPoint == REX_START_SERVICE || iScriptingPoint == REX_STOP_SERVICE)
 return REX_OK;
 int iRetVal = REX_ERROR;
 const char* pszRequestType = pEnviron->get(pEnviron, "Request-Type");
 const char* pszAppId = pEnviron->get(pEnviron, "Diameter-Application-Id");
 const char* pszCmdCode = pEnviron->get(pEnviron, "Diameter-Command-Code");
 if(!(pszRequestType && pszAppId && pszCmdCode))
 return iRetVal;
 // check the request type, Application id and command code
 /*
 Request / Response types
```

```

Diameter-Access-Request
Diameter-Access-Accept
Diameter-Access-Reject
Diameter-Accounting-Request
Diameter-Accounting-Response
*/
 if((strcmp(pszRequestType, "Diameter-Access-Request") == 0) && (strcmp(
pszAppId,"1") ==0) && (strcmp(pszCmdCode,"265\
")== 0))
 {
// our application
// example how to get DiaAttrib from the packet.
 const char* pszSessionId = pRequest ->get(pRequest,"Session-Id",0,0);
// print in trace
 if(pszSessionId)
 pEnviron->trace(pEnviron, 5, "Diameter Session Id: %s", pszSessionId);
// example: how to add dia attrib in response packet
 pResponse->put(pResponse, "Calling-Station-Id", "1,00-01-02-03-05", REX_APPEND);
 pEnviron->put(pEnviron, "Response-Type", "Diameter-Access-Accept");
 iRetVal = REX_OK;
 }
return iRetVal;
}

```

## Traces/Logs

```

09/30/2012 11:13:46.830: P88: Diameter Packet received from 10.81.79.59
09/30/2012 11:13:46.830: P88: Trace of Diameter-Access-Request packet
09/30/2012 11:13:46.830: P88: Session-Id = .;1096298391;15
09/30/2012 11:13:46.830: P88: Auth-Application-Id = 1
09/30/2012 11:13:46.830: P88: Origin-Host = 10.81.79.59
09/30/2012 11:13:46.830: P88: Origin-Realm = xyz.com
09/30/2012 11:13:46.830: P88: Destination-Realm = abc.com
09/30/2012 11:13:46.830: P88: Auth-Request-Type = 1
09/30/2012 11:13:46.830: P88: User-Name = bob
09/30/2012 11:13:46.830: P88: Tracing the packet after running the rules and policies
09/30/2012 11:13:46.830: P88: Trace of Diameter-Access-Request packet
09/30/2012 11:13:46.830: P88: Session-Id = .;1096298391;15
09/30/2012 11:13:46.830: P88: Auth-Application-Id = 1
09/30/2012 11:13:46.830: P88: Origin-Host = 10.81.79.59
09/30/2012 11:13:46.830: P88: Origin-Realm = xyz.com
09/30/2012 11:13:46.830: P88: Destination-Realm = abc.com
09/30/2012 11:13:46.830: P88: Auth-Request-Type = 1
09/30/2012 11:13:46.830: P88: User-Name = bob
09/30/2012 11:13:46.830: P88: Using Client: molly
09/30/2012 11:13:46.830: P88: Authenticating and Authorizing with Service
dia-rex-service
09/30/2012 11:13:46.830: P88: Rex: environ->get("Request-Type") ->
"Diameter-Access-Request"
09/30/2012 11:13:46.830: P88: Rex: environ->get("Diameter-Application-Id") ->
"1"
09/30/2012 11:13:46.830: P88: Rex: environ->get("Diameter-Command-Code") ->
"265"
09/30/2012 11:13:46.830: P88: Rex: request->get("Session-Id", 0) ->
".;1096298391;15"
09/30/2012 11:13:46.830: P88: Diameter Session Id: .;1096298391;15
09/30/2012 11:13:46.830: P88: Rex: response->put("Calling-Station-Id",
"1,00-01-02-03-05", 0) -> TRUE
09/30/2012 11:13:46.831: P88: Rex: environ->put("Response-Type",
"Diameter-Access-Accept") -> TRUE
09/30/2012 11:13:46.831: P88: Trace of Diameter-Access-Accept
09/30/2012 11:13:46.831: P88: Calling-Station-Id = 00-01-02-03-05

```

```
09/30/2012 11:13:46.831: P88: Auth-Application-Id = 1
09/30/2012 11:13:46.831: P88: User-Name = bob
09/30/2012 11:13:46.831: P88: Auth-Request-Type = 3
09/30/2012 11:13:46.831: P88: Result-Code = 2001
```

## Diameter Routing Agent

Service providers transform their 3G and 4G wireless networks with complex services, tiered charging, converged billing, and more by introducing increasing numbers and types of Diameter-based network elements. LTE and IMS networks are the most likely to implement these new network elements—including Policy and Charging Rules Functions (PCRF), Home Subscriber Servers (HSS), Mobility Management Entities (MME), Online Charging Systems (OCS), and others. As a result, as the traffic levels grow, these wireless networks are becoming more difficult to manage and scale without the Cisco Prime AR infrastructure.

The following sections describes the types of diameter agent and how to import the diameter command codes.

- [Diameter Relay Agent](#)
- [Diameter Proxy Agent](#)
- [Importing Diameter Command Codes](#)

## Diameter Relay Agent

Relay agent is used to forward a request to the appropriate peer based on the information included in the request. As the relay agent collects the requests from different realms to a specific realm, the configurations of network access servers for every Diameter server change is not required.

The following is an example for Diameter Relay Agent configuration:

```
[//localhost/Radius/Services/dia-relay]
[dia-relay]
Name = dia-relay
Description =
Type = diameter
Realm = cisco.com
Role = relay
Peers/
 Entries 1 to 1 from 1 total entries
 Current filter: <all>

53/
Name = 53
HostName = 10.77.240.53
IsVendorSpecific = tRUE
VendorSpecificApplicationID = 16777219
VendorID = 10415
Metric = 1
```

## Diameter Proxy Agent

Proxy agents assist in routing Diameter messages using the Diameter routing table. The messages can be modified to implement policy enforcement. A proxy agent can also be used in forwarding messages, but unlike a relay agent, a proxy agent will modify the message content to provide value added services, enforce rules on different messages or to perform tasks for a specific realm. Figure 8-1 explains the message forwarding process to another domain by a proxy agent.

**Figure 8-1** Diameter Proxy Agent

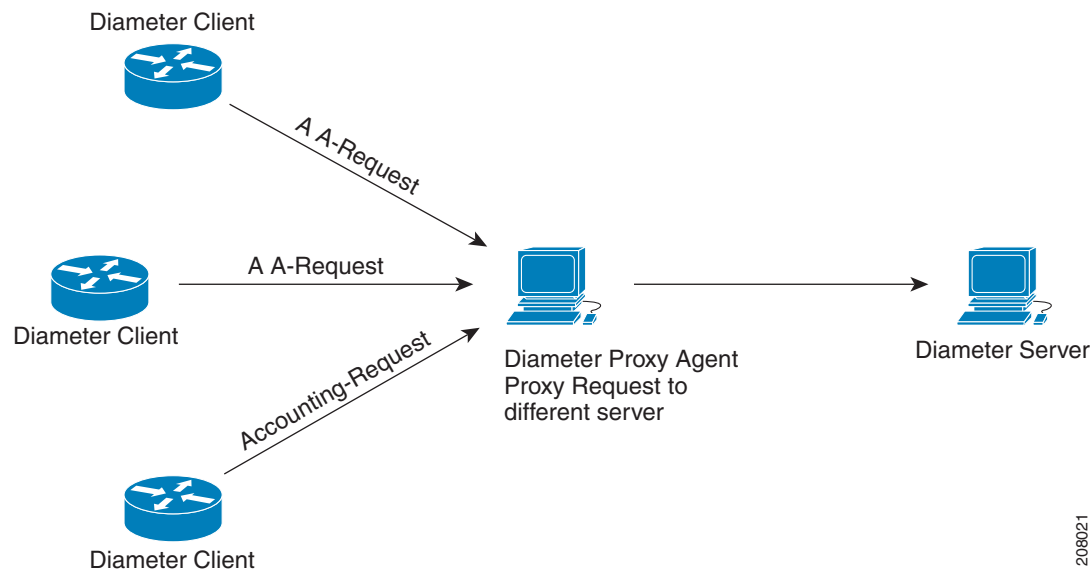

208021

Diameter proxy service works in tandem with the rule policy engine to perform the routing for multiple realms or applications. The following are the multiple peer policies supported by the proxy service:

- [RoundRobin](#)
- [FailOver](#)
- [IMSI Range Based](#)

## RoundRobin

In proxy mode, Cisco Prime AR allows distribution of incoming traffic to remote peers using equal weight-based load balancing or differential weight-based load balancing.

In the equal weight-based load balancing, all peers are assigned an equal weight. Cisco Prime AR uniformly shares the incoming load across all of the servers in the Peers list.

In differential weight-based load balancing, a unique weight is assigned to each peer in the service. Cisco Prime AR sends the incoming load to the peers in proportion to the weight configured in the peer list. By default, the weight of remote peer is set to 0. The weights need to be configured as multiples of 10 and the sum of the weights configured in the peer list should be equal to 100. Currently, in weight-based load balancing, Cisco Prime AR supports a maximum of ten peers.

For example, if you have two remote peers with the weights configured in the ratio of 50:50, both the remote peers will receive an equal number of requests. If you have two remote peers with weights configured in the ratio of 70:30, Cisco Prime AR will send 70% of the incoming traffic to one peer and the remaining 30% to another peer for the service. For configuration details, see [Configuring Diameter Proxy, page 8-23](#).

## FailOver

When Failover mode is selected, Cisco Prime AR directs requests to the first peer in the list which has the least metric value. The requests are sent to this peer until the peer is online. If the first peer goes down, Cisco Prime AR redirects all requests to the next peer in the list until with lesser metric value coming back online. When the first peer goes down, Cisco Prime AR redirects all requests to the next online peer that has the second least metric value. If the first peer comes back online, the requests are sent again to the first peer. For configuration details, see [Configuring Diameter Proxy, page 8-23](#).

## IMSI Range Based

When the International Mobile Subscriber Identity (IMSI) range mode is selected, Cisco Prime AR determines which peers have to take the incoming requests based on the IMSI range configured in the proxy service. The sticky session key must be configured to an AVP that contains the IMSI. In the proxy service, mappings are created between the peers and the IMSI ranges based on which the received packets are directed through the mapped peer.

For example, consider the peers, peer1, peer2, and peer3 with their IMSI range 10000000000000-20000000000000, 20000000000001-30000000000000, and 300000000000001-400000000000000 respectively. When a request with 25000000000000 as IMSI range is received, the request is automatically forwarded to peer2.

## Configuring Diameter Proxy

Cisco Prime AR server acts as a proxy agent when you set the role as proxy for a particular realm. In the peer list, you have to configure which application messages need to be proxied and to whom. In the example below, the Base, NASREQ messages and Accounting messages are proxied to gordan-ar1.cisco.com system.

Cisco Prime AR provides two scripting points for modifying the proxy packet. IncomingScript point will run for proxy-request message, OutgoingScript point will run for proxy-response messages specific to the given realm.

See [Table 4-21](#) for more information on Diameter Service properties.

```
[//localhost/Radius/Services/diameter-proxy]
Name = diameter-proxy
Description =
Type = diameter
Realm = cisco.com
Role = Proxy
IncomingScript~ =
OutgoingScript~ =
Applications/
Entries 1 to 1 from 1 total entries
Current filter: <all>

NASREQ/
Name = NASREQ
```

```

Description =
IsVendorSpecific = FALSE
ApplicationID = 1
StickyAVP = Session-Id
MultiAVPPosition = 1
StickyCreationCmdList = 265||271::Accounting-Record-Type=2
StickyDeletionCmdList = 275||271::Accounting-Record-Type=4
StickyTimeout = 10000
UseIMSIRangeBasedLoadBalancing = FALSE
MultiplePeersPolicy = RoundRobin
Peers/
Entries 1 to 1 from 1 total entries
Current filter: <all>

hss1/
Name = hss1
HostName = gordon-ar1
Metric = 2
Weight = 0
IMSIRange =

```

The following configuration is an example of the differential weight-based load balancing for the peers with weights configured in the ratio of 70:30. For every 10 requests the Cisco Prime AR has received for S6 Application(16777251), it distributes 7 to hss1 and 3 to hss2.

```

[//localhost/Radius/Services/diameter-proxy]
Name = diameter-proxy
Description =
Type = diameter
Realm = cisco.com
Role = Proxy
IncomingScript~ =
OutgoingScript~ =
Applications/
Entries 1 to 1 from 1 total entries
Current filter: <all>

S6Application/
Name = S6Application
Description =
IsVendorSpecific = FALSE
ApplicationID = 16777251
EnableSticky = FALSE
MultiplePeersPolicy = RoundRobin
Peers/
Entries 1 to 1 from 1 total entries
Current filter: <all>

hss1/
Name = hss1
HostName = gordon-ar1
Metric = 2
Weight = 70
hss2/
Name = hss2
HostName = henry-ar1
Metric = 1
Weight = 30

```

The following is an example for FailOver configuration:

```
[//localhost/Radius/Services/dia-failover]
Name = dia-failover
Description =
Type = diameter
Realm = cisco.com
Role = Proxy
IncomingScript~ =
OutgoingScript~ =
Applications/
Entries 1 to 1 from 1 total entries
Current filter: <all>

NASREQ/
Name = NASREQ
Description =
ApplicationID = 1
EnableSticky = FALSE
MultiplePeersPolicy = Failover
Peers/
Entries 1 to 3 from 3 total entries
Current filter: <all>

ocs1/
Name = ocs1
HostName = 10.77.240.69
Metric = 1
Weight = 0
IMSIRanges =
ocs2/
Name = ocs2
HostName = 10.77.240.70
Metric = 2
Weight = 0
IMSIRanges =
ocs3/
Name = ocs3
HostName = 10.77.240.80
Metric = 3
Weight = 0
IMSIRanges =
```

The following is an example for IMSI Range Based configuration:

```
[//localhost/Radius/Services/dia-imsi]
Name = dia-imsi
Description =
Type = diameter
Realm = epc.com
Role = Proxy
IncomingScript~ =
OutgoingScript~ =
Applications/
Entries 1 to 1 from 1 total entries
Current filter: <all>

NASREQ/
Name = NASREQ
Description =
ApplicationID = 1
EnableSticky = TRUE
StickySessionKey = Subscription-Id<Subscription-Id-Data>#1
StickyCreationCmdList = 275::Accounting-Record-Type=2
```

```
StickyDeletionCmdList = 275::Accounting-Record-Type=4
MultiplePeersPolicy = IMSIRangeBased
Peers/
Entries 1 to 2 from 2 total entries
Current filter: <all>

hss1/
Name = hss1
HostName = 10.77.240.69
Metric = 2
Weight = 0
IMSIRanges = 1000-2000
hss2/
Name = hss2
HostName = 10.77.240.70
Metric = 1
Weight = 0
IMSIRanges = 4000-6000
```

**Note**

---

The AVPs names entered in the StickySessionKey are case-sensitive. These AVPs should be available in the Cisco Prime AR Diameter Dictionary.

---

## Configuring Cisco Prime AR to Demultiplex the Diameter CCR-T

Cisco Prime AR server generates and sends multiple Credit Control Update (CCR-U) requests corresponding to an incoming diameter Credit Control Termination (CCR-T) request, while proxying Gy messages between the Gateway GPRS Support Node (GGSN) and Online charging system (OCS).

Cisco Prime AR server generates a new hop-to-hop and end-to-end diameter identifier for every CCR-U generated. The CC-Request-Number is incremented sequentially, from what the GGSN sends in the Credit Control Terminate Request (CCR-T), for each of the CCR-U generated.

Cisco Prime AR internally maintains a list of Rating Group (RG) values for which OCS sends Credit Control Update Answer (CCA-U) with Result-Code AVP value as Credit-Limit-Reached. While de-multiplexing the CCR-T request into several CCR-U, the RGs that expired are skipped. Also, Cisco Prime AR maintains the state of each CCR-U/CCA-U transaction with OCS and adds an appropriate result-code in the Multiple Service Credit Control (MSCC) AVP while sending the CCA-T response to the GGSN. Cisco Prime AR server waits until all the CCR-U transactions are completed (response received or time-out) before forwarding the CCR-T to GGSN. However, it will initiate the CCR-U (for each RG) in parallel to the OCS. During the time-out interval, if there is no response from OCS, Cisco Prime AR sends a response message to GGSN indicating failure in the delivery. [Figure 8-2](#) explains the message flow process from GGSN to OCS through Cisco Prime AR.



Figure 8-2 Message Flow between GGSN and OCS

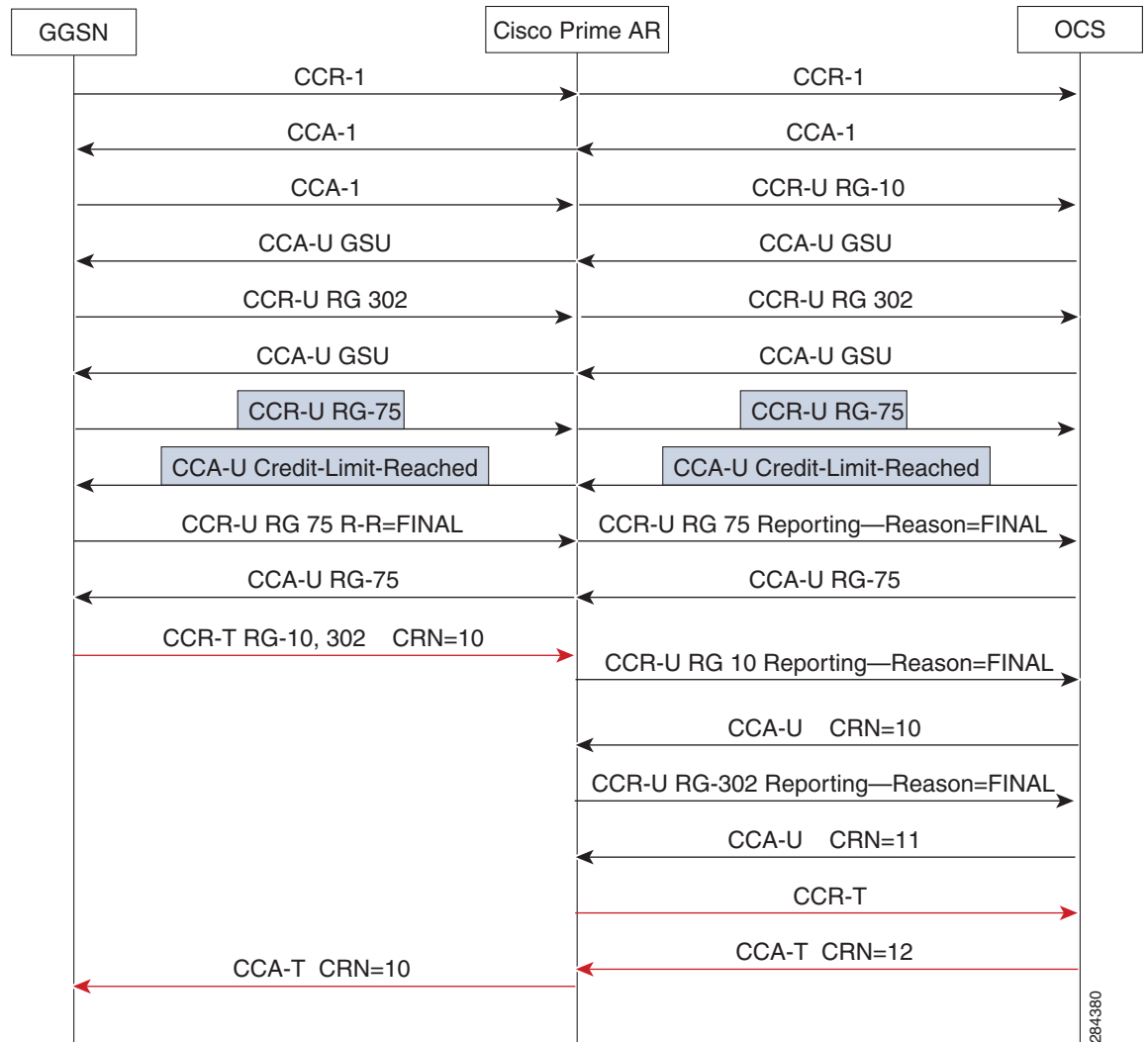

The following is an example configuration for demultiplexing the Diameter Credit Control Terminate Request:

```

[//localhost/Radius/Services/Gy-dia-service]
Name = Gy-dia-service
Description =
Type = diameter
Realm = ggsn.com
Role = Proxy
IncomingScript~ =
OutgoingScript~ =
Applications/
 Entries 1 to 1 from 1 total entries
 Current filter: <all>
 Gy/
 Name = Gy
 Description =
 IsVendorSpecific = FALSE
 ApplicationID = 4

```

```

EnableSticky = FALSE
DeMultiplexCCTerminateRequest = TRUE
MultiplePeersPolicy = Failover
Peers/
 Entries 1 to 1 from 1 total entries
 Current filter: <all>
 OCS/
 Name = OCS
 HostName = ocs.it.com
 Metric = 2
 Weight = 0

```

## Traces/Logs

### Round Robin Load Balancing Traces:

```

06/03/2012 8:54:54.193: P199: Diameter Packet received from 10.81.79.42
06/03/2012 8:54:54.193: P199: Trace of Diameter-Proxy-Request packet
06/03/2012 8:54:54.193: P199: Command code = 265
06/03/2012 8:54:54.193: P199: Session-Id = .;1096298391;1
06/03/2012 8:54:54.193: P199: Auth-Application-Id = 1
06/03/2012 8:54:54.193: P199: Origin-Host = 10.81.79.42
06/03/2012 8:54:54.193: P199: Origin-Realm = abc1.com
06/03/2012 8:54:54.193: P199: Destination-Realm = cisco.com
06/03/2012 8:54:54.193: P199: Auth-Request-Type = 3
06/03/2012 8:54:54.193: P199: User-Name = bob
06/03/2012 8:54:54.193: P199: User-Name = jane
06/03/2012 8:54:54.193: P199: <Vendor-Specific-Application-Id>
06/03/2012 8:54:54.193: P199: Command code = 265
06/03/2012 8:54:54.193: P199: Vendor-Id = 3000
06/03/2012 8:54:54.193: P199: Acct-Application-Id = 3
06/03/2012 8:54:54.193: P199: </Vendor-Specific-Application-Id>
06/03/2012 8:54:54.193: P199: <Vendor-Specific-Application-Id>
06/03/2012 8:54:54.193: P199: Command code = 265
06/03/2012 8:54:54.193: P199: Vendor-Id = 195
06/03/2012 8:54:54.193: P199: Acct-Application-Id = 3
06/03/2012 8:54:54.193: P199: </Vendor-Specific-Application-Id>
06/03/2012 8:54:54.193: P199: <Subscription-Id>
06/03/2012 8:54:54.193: P199: Command code = 265
06/03/2012 8:54:54.193: P199: Subscription-Id-Data = 1959999
06/03/2012 8:54:54.193: P199: Subscription-Id-Type = 0
06/03/2012 8:54:54.193: P199: </Subscription-Id>
06/03/2012 8:54:54.194: P199: <Subscription-Id>
06/03/2012 8:54:54.194: P199: Command code = 265
06/03/2012 8:54:54.194: P199: Subscription-Id-Data = 112456
06/03/2012 8:54:54.194: P199: Subscription-Id-Type = 1
06/03/2012 8:54:54.194: P199: </Subscription-Id>
06/03/2012 8:54:54.194: P199: Route-Record = 10.77.240.72
06/03/2012 8:54:54.194: P199: Processing the diameter proxy packet
06/03/2012 8:54:54.194: P199: Using Client: murdoch
06/03/2012 8:54:54.194: P199: Authenticating and Authorizing with Service dia-proxy
06/03/2012 8:54:54.194: P199: Service dia-proxy: Enabled Sticky
06/03/2012 8:54:54.194: P199: Service dia-proxy: Using Round Robin Load Balancing
06/03/2012 8:54:54.194: P199: Service dia-proxy: Setting the sticky entry to bob
06/03/2012 8:54:54.194: P199: Service dia-proxy: Sending request to remote peer
9,10.77.240.69
06/03/2012 8:54:54.195: Log: Destination peer changed based on Destination-Host AVP
06/03/2012 8:54:54.198: P200: Diameter Packet received from 10.77.240.69
06/03/2012 8:54:54.198: P200: Trace of Diameter-Proxy-Answer packet
06/03/2012 8:54:54.198: P200: Command code = 265
06/03/2012 8:54:54.198: P200: Session-Id = .;1096298391;1
06/03/2012 8:54:54.198: P200: Auth-Application-Id = 1

```

```

06/03/2012 8:54:54.198: P200: Auth-Request-Type = 3
06/03/2012 8:54:54.198: P200: Result-Code = 2001
06/03/2012 8:54:54.198: P200: Origin-Host = 10.77.240.69
06/03/2012 8:54:54.198: P200: Origin-Realm = cisco.com
06/03/2012 8:54:54.198: P200: User-Name = bob
06/03/2012 8:54:54.198: P200: Auth-Grace-Period = 30
06/03/2012 8:54:54.198: P200: Auth-Session-State = 0
06/03/2012 8:54:54.198: P200: Session-Timeout = 1000
06/03/2012 8:54:54.198: P200: Authorization-Lifetime = 360

```

#### FailOver Traces:

```

06/03/2012 15:12:19.500: P200: Diameter Packet received from 10.81.79.42
06/03/2012 15:12:19.500: P200: Trace of Diameter-Proxy-Request packet
06/03/2012 15:12:19.500: P200: Command code = 265
06/03/2012 15:12:19.500: P200: Session-Id = .;1096298391;1
06/03/2012 15:12:19.501: P200: Auth-Application-Id = 1
06/03/2012 15:12:19.501: P200: Origin-Host = 10.81.79.42
06/03/2012 15:12:19.501: P200: Origin-Realm = abc1.com
06/03/2012 15:12:19.501: P200: Destination-Realm = cisco.com
06/03/2012 15:12:19.501: P200: Auth-Request-Type = 3
06/03/2012 15:12:19.501: P200: User-Name = bob
06/03/2012 15:12:19.501: P200: User-Name = jane
06/03/2012 15:12:19.501: P200: <Vendor-Specific-Application-Id>
06/03/2012 15:12:19.501: P200: Command code = 265
06/03/2012 15:12:19.501: P200: Vendor-Id = 3000
06/03/2012 15:12:19.501: P200: Acct-Application-Id = 3
06/03/2012 15:12:19.501: P200: </Vendor-Specific-Application-Id>
06/03/2012 15:12:19.501: P200: <Vendor-Specific-Application-Id>
06/03/2012 15:12:19.501: P200: Command code = 265
06/03/2012 15:12:19.501: P200: Vendor-Id = 195
06/03/2012 15:12:19.502: P200: Acct-Application-Id = 3
06/03/2012 15:12:19.502: P200: </Vendor-Specific-Application-Id>
06/03/2012 15:12:19.502: P200: <Subscription-Id>
06/03/2012 15:12:19.502: P200: Command code = 265
06/03/2012 15:12:19.502: P200: Subscription-Id-Data = 1959999
06/03/2012 15:12:19.502: P200: Subscription-Id-Type = 0
06/03/2012 15:12:19.502: P200: </Subscription-Id>
06/03/2012 15:12:19.502: P200: <Subscription-Id>
06/03/2012 15:12:19.502: P200: Command code = 265
06/03/2012 15:12:19.502: P200: Subscription-Id-Data = 112456
06/03/2012 15:12:19.502: P200: Subscription-Id-Type = 1
06/03/2012 15:12:19.502: P200: </Subscription-Id>
06/03/2012 15:12:19.502: P200: Route-Record = 10.77.240.72
06/03/2012 15:12:19.502: P200: Processing the diameter proxy packet
06/03/2012 15:12:19.503: P200: Using Client: murdoch
06/03/2012 15:12:19.503: P200: Authenticating and Authorizing with Service dia-proxy
06/03/2012 15:12:19.657: P201: Diameter Packet received from 10.81.79.51
06/03/2012 15:12:19.657: P201: Trace of Diameter-Proxy-Answer packet
06/03/2012 15:12:19.657: P201: Command code = 265
06/03/2012 15:12:19.657: P201: Session-Id = .;1096298391;1
06/03/2012 15:12:19.657: P201: Auth-Application-Id = 1
06/03/2012 15:12:19.657: P201: Auth-Request-Type = 3
06/03/2012 15:12:19.657: P201: Result-Code = 2001
06/03/2012 15:12:19.657: P201: Origin-Host = 10.81.79.51
06/03/2012 15:12:19.657: P201: Origin-Realm = cisco.com
06/03/2012 15:12:19.658: P201: User-Name = bob
06/03/2012 15:12:19.658: P201: Auth-Grace-Period = 30
06/03/2012 15:12:19.658: P201: Auth-Session-State = 1
06/03/2012 15:12:19.658: P201: Session-Timeout = 30
06/03/2012 15:12:19.658: P201: Authorization-Lifetime = 29

```

### IMSI Range Based Load Balancing Traces:

```

09/30/2012 18:43:21.357: P159: Trace of Diameter-Proxy-Request packet
09/30/2012 18:43:21.357: P158: Auth-Application-Id = 1
09/30/2012 18:43:21.357: P159: Command code = 265
09/30/2012 18:43:21.357: P158: Auth-Request-Type = 3
09/30/2012 18:43:21.357: P159: Session-Id = .;1096298391;9
09/30/2012 18:43:21.357: P158: Origin-Host = 10.77.240.69
09/30/2012 18:43:21.357: P159: Auth-Application-Id = 1
09/30/2012 18:43:21.357: P158: Origin-Realm = cisco.com
09/30/2012 18:43:21.357: P159: Auth-Request-Type = 3
09/30/2012 18:43:21.357: P158: Result-Code = 2001
09/30/2012 18:43:21.357: P159: Destination-Realm = dia.com
09/30/2012 18:43:21.357: P158: User-Name = bob
09/30/2012 18:43:21.357: P159: Origin-Host = 10.77.240.54
09/30/2012 18:43:21.357: P159: Origin-Realm = cisco.in
09/30/2012 18:43:21.357: P159: User-Name = 112156000000001
09/30/2012 18:43:21.357: P159: Route-Record = 10.77.247.117
09/30/2012 18:43:21.358: P159: Authenticating and Authorizing with Service dia-proxy
09/30/2012 18:43:21.358: P160: Origin-Host = 10.77.240.69
09/30/2012 18:43:21.358: P160: Origin-Realm = cisco.com
09/30/2012 18:43:21.358: P159: Service dia-proxy: Enabled Sticky
09/30/2012 18:43:21.358: P160: Result-Code = 2001
09/30/2012 18:43:21.358: P159: Service dia-proxy: IMSI 112156000000001 found in configured
IMSI Ranges for peer 10.77.240.69
09/30/2012 18:43:21.358: P159: Service dia-proxy: Using IMSI Range Based Load Balancing
09/30/2012 18:43:21.358: P159: Service dia-proxy: Setting the sticky entry to
112156000000001
09/30/2012 18:43:21.358: P159: Service dia-proxy: Sending request to remote peer
10.77.240.69
09/30/2012 18:43:21.358: Log: Destination peer changed based on Destination-Host AVP
09/30/2012 18:43:21.359: P159: Trace of Diameter-Proxy-Answer packet
09/30/2012 18:43:21.359: P159: Command code = 265
09/30/2012 18:43:21.359: P159: Session-Id = .;1096298391;9
09/30/2012 18:43:21.359: P159: Auth-Application-Id = 1
09/30/2012 18:43:21.359: P159: Auth-Request-Type = 3
09/30/2012 18:43:21.359: P159: Origin-Host = 10.77.240.69
09/30/2012 18:43:21.359: P159: Origin-Realm = cisco.com
09/30/2012 18:43:21.359: P159: Result-Code = 2001
09/30/2012 18:43:21.359: P159: User-Name = bob

```

## Writing Diameter Proxy Extension Scripts

During the Diameter proxy process, Cisco Prime AR uses the extension point scripting to modify the packets. Scripting is supported using C and C++ (rex).

See [Configuring rex script/service for Diameter](#) for more details.



### Note

Use the request dictionary for modifying (get, put, remove) the AVPs. The AVPs names are case sensitive.

## Sample Diameter Proxy Extension Script

The following is an example of the sample diameter proxy extension script.

```

int REXAPI DiaProxyIN(int iScriptingPoint,
 rex_AttributeDictionary_t* pRequest,
 rex_AttributeDictionary_t* pResponse,
 rex_EnvironmentDictionary_t* pEnviron)
{

```

```

do
{
const char* pszAppId = pEnviron->get(pEnviron, "Diameter-Application-Id" \
);
const char* pszCmdCode= pEnviron->get(pEnviron, "Diameter-Command-Code" \
);
if(!(pszAppId && pszCmdCode))
break;
if((strcmp(pszAppId, "1") ==0) && (strcmp(pszCmdCode, "265")== 0))
{
// NASREQ Proxy Request
if(pRequest->containsKey(pRequest, "User-Name"))
{
const char* pUsername = pRequest->get(pRequest, "User-Name", 0, \
0);
pRequest->put(pRequest, "User-Name", "1,Milton", REX_REPLACE);
pRequest->put(pRequest, "Class", "1,00-01-02-03-05", REX_APPEND \
);
pRequest->remove(pRequest, "Authorization-Lifetime", 0);
}
else
pEnviron->trace(pEnviron, 5, "User-Name not found in Request \
packet ");
}
}while(0);
return REX_OK;
}

```

## Traces/Logs

```

05/07/2012 0:26:26.750: P74: Diameter Packet received from spencer-ar1.cisco.com
05/07/2012 0:26:26.750: P74: Trace of Diameter-Proxy-Request packet
05/07/2012 0:26:26.750: P74: Command code = 265
05/07/2012 0:26:26.751: P74: Session-Id =
spencer-ar1.cisco.com.cisco1.com;1273217178;706980
05/07/2012 0:26:26.751: P74: Auth-Application-Id = 1
05/07/2012 0:26:26.751: P74: Origin-Host = spencer-ar1.cisco.com
05/07/2012 0:26:26.751: P74: Origin-Realm = cisco1.com
05/07/2012 0:26:26.751: P74: Destination-Realm = abc.com
05/07/2012 0:26:26.751: P74: Auth-Request-Type = 3
05/07/2012 0:26:26.751: P74: User-Name = bob
05/07/2012 0:26:26.751: P74: Authorization-Lifetime = 49
05/07/2012 0:26:26.751: P74: Route-Record = toby-ar1.cisco.com
05/07/2012 0:26:26.751: P74: Processing the diameter proxy packet
05/07/2012 0:26:26.751: P74: Running Diameter Proxy Script: diaproxyin
05/07/2012 0:26:26.751: P74: Rex: environ->get("Diameter-Application-Id") -> "1"
05/07/2012 0:26:26.751: P74: Rex: environ->get("Diameter-Command-Code") -> "265"
05/07/2012 0:26:26.751: P74: Rex: request->containsKey("User-Name") -> TRUE
05/07/2012 0:26:26.751: P74: Rex: request->get("User-Name", 0) -> "bob"
05/07/2012 0:26:26.751: P74: Rex: request->put("User-Name", "1,Milton", 0) -> TRUE
05/07/2012 0:26:26.751: P74: Rex: request->put("Class", "1,00-01-02-03-05", 0) ->
TRUE
05/07/2012 0:26:26.751: P74: Rex: request->remove("Authorization-Lifetime") -> TRUE
05/07/2012 0:26:26.751: P74: After the alteration...
05/07/2012 0:26:26.751: P74: Trace of Diameter-Proxy-Request packet
05/07/2012 0:26:26.751: P74: Command code = 265
05/07/2012 0:26:26.751: P74: Session-Id =
spencer-ar1.cisco.com.cisco1.com;1273217178;706980
05/07/2012 0:26:26.751: P74: Auth-Application-Id = 1
05/07/2012 0:26:26.751: P74: Origin-Host = spencer-ar1.cisco.com
05/07/2012 0:26:26.751: P74: Origin-Realm = cisco1.com

```

```

05/07/2012 0:26:26.751: P74: Destination-Realm = abc.com
05/07/2012 0:26:26.751: P74: Auth-Request-Type = 3
05/07/2012 0:26:26.751: P74: User-Name = Milton
05/07/2012 0:26:26.751: P74: Route-Record = toby-ar1.cisco.com
05/07/2012 0:26:26.751: P74: Class = 00-01-02-03-05
05/07/2012 0:26:26.760: P75: Diameter Packet received from donald-ar1.cisco.com
05/07/2012 0:26:26.760: P75: Trace of Diameter-Proxy-Answer packet
05/07/2012 0:26:26.760: P75: Command code = 265
05/07/2012 0:26:26.760: P75: Session-Id =
spencer-ar1.cisco.com.cisco1.com;1273217178;706980
05/07/2012 0:26:26.760: P75: Auth-Application-Id = 1
05/07/2012 0:26:26.760: P75: Auth-Request-Type = 3
05/07/2012 0:26:26.760: P75: Result-Code = 2001
05/07/2012 0:26:26.760: P75: Origin-Host = donald-ar1.cisco.com
05/07/2012 0:26:26.760: P75: Origin-Realm = abc.com
05/07/2012 0:26:26.760: P75: User-Name = aantoniim
05/07/2012 0:26:26.760: P75: Auth-Grace-Period = 30
05/07/2012 0:26:26.760: P75: Auth-Session-State = 0
05/07/2012 0:26:26.760: P75: Session-Timeout = 300
05/07/2012 0:26:26.761: P75: Processing the diameter proxy packet
05/07/2012 0:26:26.761: P75: Running Diameter Proxy Script: diaproxyout
05/07/2012 0:26:26.761: P75: Rex: request->get("User-Name", 0) -> "aantoniim"
05/07/2012 0:26:26.761: P75: After the alteration...
05/07/2012 0:26:26.761: P75: Trace of Diameter-Proxy-Answer packet
05/07/2012 0:26:26.761: P75: Command code = 265
05/07/2012 0:26:26.761: P75: Session-Id =
spencer-ar1.cisco.com.cisco1.com;1273217178;706980
05/07/2012 0:26:26.761: P75: Auth-Application-Id = 1
05/07/2012 0:26:26.761: P75: Auth-Request-Type = 3
05/07/2012 0:26:26.761: P75: Result-Code = 2001
05/07/2012 0:26:26.761: P75: Origin-Host = donald-ar1.cisco.com
05/07/2012 0:26:26.761: P75: Origin-Realm = abc.com
05/07/2012 0:26:26.761: P75: User-Name = aantoniim
05/07/2012 0:26:26.761: P75: Auth-Grace-Period = 30
05/07/2012 0:26:26.761: P75: Auth-Session-State = 0

```

## Importing Diameter Command Codes

To import the command codes:

- 
- Step 1** Import the Application command code for AVP's using `/cisco-ar/bin/aregcmd -sf` command. The S6a, Gx, and Gy command codes are available in `/cisco-ar/examples/cli` directory. For example, `/cisco-ar/examples/cli/add-3Gpp-Gx-ApplicationAVPs.rc`.
  - Step 2** Import the Application using `/cisco-ar/bin/aregcmd -sf` command. For example, `/cisco-ar/examples/cli/add-3Gpp-Gx-Application.rc`.
  - Step 3** Restart the Cisco Prime AR server.
- 

## Support for SCTP including Multihoming

Cisco Prime AR release enhances the diameter support to the more reliable transport mechanism such as SCTP with multi-homing.

In a SCTP connection, each of the two endpoints during an SCTP association setup can specify multiple points of attachment. Having multiple interfaces allows the data to be automatically sent to alternate addresses when failures occur. Using this support, the Cisco Prime AR runs successfully even when a failure occurs in any of the multiple interfaces.

```
[//localhost/Radius/advanced/diameter/transportManagement]
 Identity = localhost
 Realm = abc.com
 TCPListenPort = 3868
 SCTPListenPort = 3868
 EnableIPV6 = FALSE
 WatchdogTimeout = 500
 ReconnectInterval = 500
 MaxReconnections = 3
 RequestRetransmissionInterval = 100
 MaxRequestRetransmissionCount = 3
 ReceiveBufferSize = 2048
 AdvertisedHostName/

--> cd AdvertisedHostName
--> add 1 10.77.240.135
--> add 2 10.77.240.136
--> add 3 10.77.240.137
--> ls
[//localhost/Radius/advanced/diameter/transportManagement/AdvertisedHostName]
1. 10.77.240.135
2. 10.77.240.136
3. 10.77.240.137
```

**Note**

The number of AVPs should be set greater than or equal to the number of AdvertisedHostName in order to exchange the capabilities between peers.







## CHAPTER 9

# Extensible Authentication Protocols

---

Cisco Prime Access Registrar (Cisco Prime AR) supports the Extensible Authentication Protocol (EAP) to provide a common protocol for differing authentication mechanisms. EAP enables the dynamic selection of the authentication mechanism at authentication time based on information transmitted in the Access-Request. (This type of EAP authentication mechanism is called an authentication exchange.)

Extensible Authentication Protocols (EAP) provide for support of multiple authentication methods. Cisco Prime AR supports the following EAP authentication methods:

- [EAP-AKA](#)
- [EAP-FAST](#)
- [EAP-GTC](#)
- [EAP-LEAP](#)
- [EAP-MD5](#)
- [EAP-Negotiate](#)
- [EAP-MSChapV2](#)
- [EAP-SIM](#)
- [EAP-Transport Level Security \(TLS\)](#)
- [EAP-TTLS](#)
- [Protected EAP](#)
  - [PEAP Version 0 \(Microsoft PEAP\)](#)
  - [PEAP Version 1 \(Cisco PEAP\)](#)

In general, you enable each EAP method by creating and configuring a service of the desired type. Use the **radclient** test tool to confirm that the EAP service has been properly configured and is operational.

Both versions of Protected EAP (PEAP) are able to use other EAP methods as the authentication mechanism that is protected by PEAP encryption. For PEAP Version 0, the supported authentication methods are EAP-MSChapV2, EAP-SIM, EAP-TLS and EAP-Negotiate. For PEAP Version 1, the supported authentication methods are EAP-GTC, EAP-SIM, EAP-TLS and EAP-Negotiate.

The PEAP protocol consists of two phases: an authentication handshake phase and a tunnel phase where another complete EAP authentication exchange takes place protected by the session keys negotiated by phase one. Cisco Prime AR supports the tunneling of other EAP methods within the PEAP phase two exchange.

## EAP-AKA

Authentication and Key Agreement (AKA) is an EAP mechanism for authentication and session key distribution. It is used in the 3rd generation mobile networks Universal Mobile Telecommunications System (UMTS) and CDMA2000. AKA is based on symmetric keys, and typically runs in a UMTS Subscriber Identity Module (USIM), or a (Removable) User Identity Module ((R) UIM), similar to a smart card. EAP-AKA (Extensible Authentication Protocol Method for UMTS Authentication and Key Agreement) includes optional identity privacy support, optional result indications, and an optional fast reauthentication procedure.

In support of EAP-AKA, the following features are supported:

- support of MAP protocol over SIGTRAN
- support of HLR and/or HSS (3GPP compliant)
- Wx interface
- Support M3UA-SIGTRAN over IP

For more information on Wx Interface Support, see the [Wx Interface Support for SubscriberDB Lookup, page 17-48](#).

Cisco Prime AR server supports migration to a converged IP Next Generation Networks (IP NGN) by supporting SS7 and SIGTRAN (SS7 over IP) for HLR communication to enable the seamlessly transition to next-generation IP-based signaling networks.

Cisco Prime AR supports M3UA-SIGTRAN to fetch the authentication vectors from HLR for EAP-AKA authentication, See [SIGTRAN-M3UA](#) for more information.

EAP-AKA is based on rfc-4187 (<http://www.ietf.org/rfc/rfc4187.txt>). This document specifies the details of the algorithms and messages.

This section contains the following topics:

- [Configuring EAP-AKA, page 9-2](#)
- [Testing EAP-AKA with radclient, page 9-5](#)

## Configuring EAP-AKA

You can use `aregcmd` to create and configure a service of type `eap-aka`.

[Table 9-1](#) lists and describes the EAP-AKA service properties.

**Table 9-1 EAP-AKA Service Properties**

| Property              | Description                                                                                                                                                                                                                                                                                           |
|-----------------------|-------------------------------------------------------------------------------------------------------------------------------------------------------------------------------------------------------------------------------------------------------------------------------------------------------|
| AlwaysRequestIdentity | When True, enables the server to obtain the subscriber's identity via EAP/AKA messages instead of relying on the EAP messages alone. This might be useful in cases where intermediate software layers can modify the identity field of the EAP-Response/Identity message. The default value is False. |
| EnableIdentityPrivacy | When True, the identity privacy feature is enabled. The default value is False.                                                                                                                                                                                                                       |

**Table 9-1 EAP-AKA Service Properties (continued)**

| Property                 | Description                                                                                                                                                                                                                                                                                                                                                                                                                                                                                                                                         |
|--------------------------|-----------------------------------------------------------------------------------------------------------------------------------------------------------------------------------------------------------------------------------------------------------------------------------------------------------------------------------------------------------------------------------------------------------------------------------------------------------------------------------------------------------------------------------------------------|
| PseudonymSecret          | <p>The secret string that is used as the basis for protecting identities when identity privacy is enabled. This should be at least 16 characters long and have a value that is impossible for an outsider to guess. The default value is secret.</p> <p><b>Note</b> It is very important to change PseudonymSecret from its default value to a more secure value when identity privacy is enabled for the first time.</p>                                                                                                                           |
| PseudonymRenewtime       | <p>Specifies the maximum age a pseudonym can have before it is renewed. When the server receives a valid pseudonym that is older than this, it generates a new pseudonym for that subscriber. The value is specified as a string consisting of pairs of numbers and units, where the units might be of the following: M, Minute, Minutes, H, Hour, Hours, D, Day, Days, W, Week, Weeks. The default value is "24 Hours".</p> <p>Examples are: "8 Hours", "10 Hours 30 Minutes", "5 D 6 H 10 M"</p>                                                  |
| PseudonymLifetime        | <p>Specifies the maximum age a pseudonym can have before it is rejected by the server, forcing the subscriber to authenticate using its permanent identity. The value is specified as a string consisting of pairs of numbers and units, where the units might be one of the following: M, Minute, Minutes, H, Hour, Hours, D, Day, Days, W, Week, Weeks. It can also be Forever, in which case, pseudonyms do not have a maximum age. The default value is "Forever".</p> <p>Examples are: "Forever", "3 Days 12 Hours 15 Minutes", "52 Weeks"</p> |
| EnableReauthentication   | <p>When True, the fast reauthentication option is enabled. The default value is False.</p>                                                                                                                                                                                                                                                                                                                                                                                                                                                          |
| MaximumReauthentications | <p>Specifies the maximum number of times a reauthentication identity might be reused before it must be renewed. The default value is 16.</p>                                                                                                                                                                                                                                                                                                                                                                                                        |
| ReauthenticationTimeout  | <p>Specifies the time in seconds that reauthentication identities are cached by the server. Subscribers that attempt to reauthenticate using identities that are older than this value will be forced to use full authentication instead. The default value is 3600 (one hour).</p>                                                                                                                                                                                                                                                                 |
| ReauthenticationRealm    | <p>Optional. If you configure the realm, this value is appended to the FastReauthenticationUserId.</p>                                                                                                                                                                                                                                                                                                                                                                                                                                              |
| AuthenticationTimeout    | <p>Time in seconds to wait for authentication to complete. The default is 2 minutes; range is 10 seconds to 10 minutes.</p>                                                                                                                                                                                                                                                                                                                                                                                                                         |
| QuintetGenerationScript~ | <p>Optional. If the script is set, the custom scripting point can be used to read the quintets from a flat file or generate quintets instead of fetching the quintets from HLR. If the script is not set, the Cisco Prime AR sends the request to HLR configured in remote server to fetch the quintets.</p>                                                                                                                                                                                                                                        |
| UseProtectedResults      | <p>Enables or disables the use of protected results messages. Results messages indicate the state of the authentication but are cryptographically protected.</p>                                                                                                                                                                                                                                                                                                                                                                                    |
| TripletCacheTimeout      | <p>Required; timeout value of triplet cache.</p>                                                                                                                                                                                                                                                                                                                                                                                                                                                                                                    |

**Table 9-1 EAP-AKA Service Properties (continued)**

| Property               | Description                                                                                                                                                                                                                                                                                                                                                                          |
|------------------------|--------------------------------------------------------------------------------------------------------------------------------------------------------------------------------------------------------------------------------------------------------------------------------------------------------------------------------------------------------------------------------------|
| Subscriber_DBLookup    | Required. Must be set to either DIAMETER or SIGTRAN-M3UA.<br><br>When set to DIAMETER, the HSS lookup happens using the Diameter Wx Interface. You need to configure the DestinationRealm to send the Diameter packets to the RemoteServer.<br><br>When set to SIGTRAN-M3UA, the HLR/HSS lookup happens using the SIGTRAN protocol. You need to configure the SIGTRAN remote server. |
| FetchAuthorizationInfo | Required. When set True, it fetches MSISDN from HLR.<br><br>This field is displayed when you set Subscriber_DBLookup as SIGTRAN-M3UA.                                                                                                                                                                                                                                                |
| IncomingScript~        | Optional script Cisco Prime AR server runs when it receives a request from a client for an EAP-AKA/EAP-SIM service.                                                                                                                                                                                                                                                                  |
| OutgoingScript~        | Optional script Cisco Prime AR server runs before it sends a response to a client using an EAP-AKA/EAP-SIM service.                                                                                                                                                                                                                                                                  |
| OutageScript~          | Optional. If set to the name of a script, Cisco Prime AR runs the script when an outage occurs. This property allows you to create a script that notifies you when the server detects a failure.                                                                                                                                                                                     |
| RemoteServers          | Remote server which can provide the service.                                                                                                                                                                                                                                                                                                                                         |

To enable EAP-AKA authentication:

**Step 1** Launch **aregcmd** and create an EAP-AKA service.

```
cd /Radius/Services
add eap-aka-service
```

**Step 2** Change directory to the service and set its type to eap-aka.

```
cd eap-aka-service
set Type eap-aka
```

The following example shows the default configuration for an EAP-AKA service:

```
[//localhost/Radius/Services/test]
 Name = test
 Description =
 Type = eap-aka
 AlwaysRequestIdentity = False
 EnableIdentityPrivacy = False
 PseudonymSecret = <encrypted>
 PseudonymRenewtime = "24 Hours"
 PseudonymLifetime = Forever
 Generate3GPPCompliantPseudonym = False
 EnableReauthentication = False
```

```

MaximumReauthentications = 16
ReauthenticationTimeout = 3600
ReauthenticationRealm =
AuthenticationTimeout = 120
QuintetGenerationScript~ =
UseProtectedResults = False
SendReAuthIDInAccept = False
SubscriberDBLookup = SIGTRAN-M3UA
FetchAuthorizationInfo = FALSE
MultipleServersPolicy = Failover
IncomingScript~ =
OutgoingScript~ =
OutageScript~ =
RemoteServers/

```

The following example shows the default configuration for an EAP-AKA Wx service:

```

[//localhost/Radius/Services/eap-aka-wx]
Name = eap-aka-wx
Description =
Type = eap-aka
AlwaysRequestIdentity = False
EnableIdentityPrivacy = False
PseudonymSecret = <encrypted>
PseudonymRenewtime = "24 Hours"
PseudonymLifetime = Forever
Generate3GPPCompliantPseudonym = False
EnableReauthentication = False
MaximumReauthentications = 16
ReauthenticationTimeout = 3600
ReauthenticationRealm =
AuthenticationTimeout = 120
QuintetGenerationScript~ =
UseProtectedResults = False
SendReAuthIDInAccept = False
SubscriberDBLookup = Diameter
DestinationRealm = mpc.com
PreRequestTranslationScript~ =
PostRequestTranslationScript~ =
PreResponseTranslationScript~ =
PostResponseTranslationScript~ =

```

## Testing EAP-AKA with radclient

To test the EAP-AKA service, launch **radclient** and use the **simple\_eap\_aka\_test** command. The **simple\_eap\_aka\_test** command sends an Access-Request for the designated user with the user's secret key and sequence number.

The response packet should indicate an Access-Accept if authentication was successful. View the response packet to ensure the authentication was successful.

```
simple_eap_aka_test bob secret 2
```

To test from radclient, you have to configure **/cisco-ar/conf/imsi.conf** file on radius server and reload the server. This file content should have imsi users in the format below:

```
<username>:<secret>:<sequence number>
```

For example:

```
bob:bob:1
```

# EAP-FAST

Cisco Prime AR supports the EAP-FAST authentication method. EAP-FAST uses the EAP-MSChapV2 method for credential provisioning and EAP-GTC for authentication. Credential provisioning typically occurs only during the client's initial EAP-FAST authentication. Subsequent authentications rely on the provisioned credential and will usually omit the provisioning step.

EAP-FAST is an authentication protocol designed to address the performance shortcomings of prior TLS-based EAP methods while retaining features such as identity privacy and support for password-based protocols. The EAP-FAST protocol is described by the IETF draft *draft-cam-winget-eap-fast-00.txt*.

The EAP-FAST credential is known as a Protected Access Credential (PAC) and contains information used to secure the authentication operations. Parts of the PAC are encrypted by the server and are not visible to other entities. Clients are expected to securely store PACs locally for use during authentication.

Configuring EAP-FAST involves creating and configuring the required EAP-MSChapV2 and EAP-GTC services as well as the EAP-FAST service with the appropriate parameters.

You can use the **radclient** test tool to confirm that the EAP services are properly configured and operational.

This section contains the following topics:

- [Configuring EAP-FAST](#)
- [EAP-FAST Keystores](#)
- [Testing EAP-FAST with radclient](#)
- [Parameters Used for Certificate-Based Authentication](#)
- [PAC—Credential Export Utility](#)

## Configuring EAP-FAST

You can use **aregcmd** to create and configure a service of type *eap-fast*.

To enable EAP-FAST:

---

**Step 1** Launch **aregcmd** and create an EAP-FAST service.

```
cd /Radius/Services
add eap-fast-service
```

**Step 2** Change directory to the service and set its type to *eap-fast*.

```
cd eap-fast-service
set type eap-fast
```

**Step 3** Set the AuthorityIdentifier:

```
set AuthorityIdentifier authority-identifier
```

**Step 4** : Set the AuthorityInformation:

**set AuthorityInformation *authority-information***

**Step 5** : Set the AuthenticationService:

**set AuthenticationService *eap-gtc-service***

**Step 6** :Set the ProvisionService:

**set ProvisionService *eap-mschapv2-service***

The follow example shows the default configuration for an EAP-FAST service:

```
[//localhost/Radius/Services/eap-fast-service]
Name = eap-fast-service
Description =
Type = eap-fast
IncomingScript~ =
OutgoingScript~ =
MaximumMessageSize = 1024
PrivateKeyPassword = <encrypted>
ServerCertificateFile = /opt/CSCOar/pki/server-cert.pem
ServerKeyFile = /opt/CSCOar/pki/server-key.pem
CACertificateFile = /opt/CSCOar/pki/root-cert.pem
CACertificatePath = /opt/CSCOar/pki
CRLDistributionURL =
ClientVerificationMode = Optional
VerificationDepth = 4
EnableSessionCache = true
UseECCCertificates = true
SessionTimeout = "5 Minutes"
AuthenticationTimeout = 120
```

Table 9-2 lists and describes the EAP-FAST service properties.

**Table 9-2 EAP-FAST Service Properties**

| Property             | Description                                                                                                                                                                                                                                                                                                                                                        |
|----------------------|--------------------------------------------------------------------------------------------------------------------------------------------------------------------------------------------------------------------------------------------------------------------------------------------------------------------------------------------------------------------|
| IncomingScript       | Optional script Cisco Prime AR server runs when it receives a request from a client for EAP-FAST service.                                                                                                                                                                                                                                                          |
| OutgoingScript       | Optional script Cisco Prime AR server runs before it sends a response to a client using EAP-FAST.                                                                                                                                                                                                                                                                  |
| AuthorityIdentifier  | A string that uniquely identifies the credential (PAC) issuer. The client uses this value to select the correct PAC to use with a particular server from the set of PACs it might have stored locally.<br><br>Ensure that the AuthorityIdentifier is globally unique and that it does not conflict with identifiers used by other EAP-FAST servers or PAC issuers. |
| AuthorityInformation | A string that provides a descriptive text for this credential issuer. The value can be displayed to the client for identification purposes and might contain the enterprise or server names.                                                                                                                                                                       |
| MaximumMessageSize   | Indicates the maximum length in bytes that a PEAP or EAP-TLS message can have before it is fragmented.                                                                                                                                                                                                                                                             |
| PrivateKeyPassword   | The password used to protect the server's private key.                                                                                                                                                                                                                                                                                                             |

Table 9-2 EAP-FAST Service Properties (continued)

| Property              | Description                                                                                                                                                                                                                                                                                                                                                                                                                                                                                                                                                                                                                                                                                                                                                                                                                                                                                                                                                                                                                                                                                                                                          |
|-----------------------|------------------------------------------------------------------------------------------------------------------------------------------------------------------------------------------------------------------------------------------------------------------------------------------------------------------------------------------------------------------------------------------------------------------------------------------------------------------------------------------------------------------------------------------------------------------------------------------------------------------------------------------------------------------------------------------------------------------------------------------------------------------------------------------------------------------------------------------------------------------------------------------------------------------------------------------------------------------------------------------------------------------------------------------------------------------------------------------------------------------------------------------------------|
| ServerCertificateFile | The full pathname of the file containing the server's certificate or certificate chain used during the TLS exchange. The pathname can be optionally prefixed with a special string that indicates the type of encoding used for the certificate. The two valid encoding prefixes are PEM and DER. If an encoding prefix is not present, the file is assumed to be in PEM format.                                                                                                                                                                                                                                                                                                                                                                                                                                                                                                                                                                                                                                                                                                                                                                     |
| ServerKeyFile         | <p>The full pathname of the file containing the server's RSA or ECC private key. The pathname can be optionally prefixed with a special string that indicates the type of encoding used for the certificate. The two valid encoding prefixes are "PEM" and "DER". If an encoding prefix is not present, the file is assumed to be in PEM format.</p> <p>The following example assumes that the subdirectory <b>pki</b> under <b>/cisco-ar</b> contains the server's certificate file. The file <b>server-key.pem</b> is assumed to be in PEM format. The file extension <b>.pem</b> is not significant.</p> <p style="text-align: center;"><b>set ServerKeyFile PEM:/cisco-ar/pki/server-key.pem</b></p>                                                                                                                                                                                                                                                                                                                                                                                                                                             |
| CACertificateFile     | The full pathname of the file containing trusted CA certificates used for client verification. The file can contain more than one certificate, but all certificates must be in PEM format. DER encoding is not allowed.                                                                                                                                                                                                                                                                                                                                                                                                                                                                                                                                                                                                                                                                                                                                                                                                                                                                                                                              |
| CACertificatePath     | <p>The name of a directory containing trusted CA certificates (in PEM format) used for client verification. This parameter is optional, and if it is used there are some special preparations required for the directory it references.</p> <p>Each certificate file in this directory must contain exactly one certificate in PEM format. The server looks up the certificate files using the MD5 hash value of the certificate's subject name as a key. The directory must therefore also contain a set of symbolic links each of which points to an actual certificate file. The name of each symbolic link is the hash of the subject name of the certificate.</p> <p>For example, if a certificate file named <b>ca-cert.pem</b> is located in the CACertificatePath directory, and the MD5 hash of the subject name contained in <b>ca-cert.path.pem</b> is 1b96dd93, then a symbolic link named 1b96dd93 must point to <b>ca-cert.pem</b>.</p> <p>If there are subject name collisions such as multiple certificates with the same subject name, each link name must be indexed with a numeric extension as in 1b96dd93.0 and 1b96dd93.1.</p> |
| CRLDistributionURL    | <p>Optional. Enter the URL that Cisco Prime AR should use to retrieve the CRL. You can specify a URL that uses HTTP or LDAP.</p> <p>The following is an example for an HTTP URL: &lt;<br/> <pre>//crl.verisign.com/pca1.1.1.crl&gt;.</pre> </p> <p>The following is an example for an LDAP URL:<br/> <pre>ldap://209.165.200.225:388/CN=development-CA,CN=acs-westcoast2,CN=CDP,CN=Public Key Services,CN=Services,CN=Configuration,DC=cisco,DC=com</pre> </p>                                                                                                                                                                                                                                                                                                                                                                                                                                                                                                                                                                                                                                                                                       |



**Table 9-2 EAP-FAST Service Properties (continued)**

| Property               | Description                                                                                                                                                                                                                                                                                                                                                                                                                                                                                                                             |
|------------------------|-----------------------------------------------------------------------------------------------------------------------------------------------------------------------------------------------------------------------------------------------------------------------------------------------------------------------------------------------------------------------------------------------------------------------------------------------------------------------------------------------------------------------------------------|
| ClientVerificationMode | <p>Specifies the type of verification used for client certificates. Must be set to one of RequireCertificate, None, or Optional.</p> <ul style="list-style-type: none"> <li>RequireCertificate causes the server to request a client certificate and authentication fails if the client refuses to provide one.</li> <li>None will not request a client certificate.</li> <li>Optional causes the server to request a client certificate but the client is allowed to refuse to provide one.</li> </ul>                                 |
| VerificationDepth      | <p>Specifies the maximum length of the certificate chain used for client verification.</p>                                                                                                                                                                                                                                                                                                                                                                                                                                              |
| UseECCCertificates     | <p>Determines the applicability of the authentication mechanism in SmartGrid Solutions, see the <a href="#">Smart Grid Solution Management, page 17-50</a> for more information.</p> <p>When UseECCCertificates is set to True, it can use the ECC, RSA, or combination of both certificate for certificate based verification.</p> <p>When UseECCCertificates is set to False, it can only use the RSA certificate for certificate based verification. The default location to fetch the certificate file is <b>/cisco-ar/pki</b>.</p> |
| EnableSessionCache     | <p>Specifies whether TLS session caching (fast reconnect) is enabled or not. Set to True to enable session caching; otherwise set to False.</p>                                                                                                                                                                                                                                                                                                                                                                                         |
| SessionTimeout         | <p>If TLS session caching (fast reconnect) is enabled, SessionTimeout specifies the maximum lifetime of a TLS session. Expired sessions are removed from the cache and will require a subsequent full authentication.</p> <p>SessionTimeout is specified as a string consisting of pairs of numbers and units, where units might be one of the following: M, Minute, Minutes, H, Hour, Hours, D, Day, Days, W, Week, Weeks, as in the following:</p> <p style="text-align: center;"><b>Set SessionTimeout “1 Hour 45 Minutes”</b></p>   |
| AuthenticationTimeout  | <p>Mandatory; specifies time (in seconds) to wait before an authentication request times out; defaults to 120.</p>                                                                                                                                                                                                                                                                                                                                                                                                                      |
| CredentialLifetime     | <p>Specifies the maximum lifetime of a Protected Access Credential (PAC). Clients that successfully authenticate with an expired PAC will be reprovisioned with a new PAC.</p> <p>CredentialLifetime is specified as a string consisting of pairs of numbers and units, where units might be one of the following: M, Minute, Minutes, H, Hour, Hours, D, Day, Days, W, Week, Weeks. Credentials that never expire should be specified as Forever.</p>                                                                                  |
| AuthenticationService  | <p>Specifies the name of the EAP-GTC service is used for authentication. The named service must have the UseLabels parameter set to True.</p>                                                                                                                                                                                                                                                                                                                                                                                           |
| ProvisionMode          | <p>Specifies the TLS mode used for provisioning. Clients only support the default Anonymous mode.</p>                                                                                                                                                                                                                                                                                                                                                                                                                                   |

**Table 9-2** EAP-FAST Service Properties (continued)

| Property           | Description                                                                                                                                                                                                                                         |
|--------------------|-----------------------------------------------------------------------------------------------------------------------------------------------------------------------------------------------------------------------------------------------------|
| ProvisionService   | Specifies the name of the EAP-MSChapV2 service used for provisioning.                                                                                                                                                                               |
| AlwaysAuthenticate | Indicates whether provisioning should always automatically rollover into authentication without relying on a separate session. Most environments, particularly wireless, will perform better when this parameter is set to True, the default value. |

**Note**

Cisco Prime AR verifies the certificate during the TLS-based authentication. CRL validation is done before accepting a client certificate during the TLS authentication.

## EAP-FAST Keystores

The EAP-FAST service manages a set of keys used to protect the security and integrity of the PACs it issues. The keys are stored in **/Radius/Advanced/KeyStores/EAP-FAST** and are maintained automatically requiring minimal administration. Administrators can specify the maximum number of keys that are stored and the frequency of key updates.

The following is the default KeyStores settings:

```
[//localhost/Radius/Advanced/KeyStores/EAP-FAST]
 NumberOfKeys = 256
 RolloverPeriod = "1 Week"
```

Table 9-3 defines the KeyStores properties.

**Table 9-3** KeyStores Properties

| Property       | Description                                                                         |
|----------------|-------------------------------------------------------------------------------------|
| NumberOfKeys   | Number (from 1-1024) that specifies the maximum number of keys stored for EAP-FAST. |
| RolloverPeriod | Specifies the amount of time between key updates.                                   |

## Testing EAP-FAST with radclient

There are two distinct phases to testing EAP-FAST: provisioning and authentication. In the instructions below, Step 2 and Step 3 test provisioning and Steps 4 and Step 5 test authentication. At least one successful provisioning phase must be completed prior to testing authentication. Testing EAP-FAST with **radclient** requires that the EAP-MSChapV2 and EAP-GTC services be configured and functional.

The following instructions and examples assume that the AlwaysAuthenticate parameter has been set to False for testing purposes. This permits the provisioning and authentication steps to be tested separately. Most installations will set AlwaysAuthenticate to True for production use, and **radclient** works with that setting, but might display extra error messages that you can ignore.

To test EAP-FAST using **radclient**:

---

**Step 1** Start `radclient`.

```
cd /cisco-ar/usrbin
./radclient -s
```

**Step 2** Specify the inner provisioning method

```
tunnel eap-mschapv2
```

The only allowable method for provisioning is `eap-mschapv2`.

**Step 3** Provision a new PAC:

```
simple_eap_fast_test user-name password
```

**Step 4** Specify the inner authentication method.

```
tunnel eap-gtc
```

The only allowable method for authentication is `eap-gtc`.

**Step 5** Authenticate using the PAC.

```
simple_eap_fast_test user-name password
```

---

The `simple_eap_fast_test` command passes its arguments to the inner authentication mechanism which in turn treats the arguments as a username and a password. The command in Step 3 should result in provisioning a new PAC, and Step 5 should result in successful authentication using that PAC.

## PAC Provisioning

The following example provisions a PAC for user bob.

```
pac show
```

```
No PAC(s) available to show
```

```
tunnel eap-mschapv2
```

```
PEAP tunnel method is eap-mschapv2
EAP-FAST tunnel method is eap-mschapv2
```

```
simple_eap_fast_test bob bob
```

```
EAP-FAST authentication status:
 [0x0e07] TLS authentication succeeded
Response to EAP-FAST message was not an Access-Accept
p012
```

```
pac show
```

```
PAC 1 version 1 (219 bytes)
```

```

A-ID : Cisco Prime AR
A-ID-Info : Cisco Prime Access Registrar
I-ID : bob
Expires : Never (0)
Key# : 12
TLV 1 : PAC-Key (1) mandatory (32 bytes)
TLV 2 : PAC-Opaque (2) mandatory (120 bytes)
TLV 3 : PAC-Info (9) mandatory (51 bytes)

```

In this example the **simple\_eap\_fast\_test** command indicates that it did not receive an `AccessAccept`. This is normal because the provisioning step always results in an `AccessReject` even when a new PAC has been successfully provisioned. The last **pac show** command displayed some status information from the new PAC and is used to verify that provisioning succeeded and authentication can now be tested. The PAC information displayed will vary and depends on how EAP-FAST is configured.

## Authentication

The following example authenticates user bob (continuing from the [PAC Provisioning](#) example).

### tunnel eap-gtc

```

PEAP tunnel method is eap-gtc
EAP-FAST tunnel method is eap-gtc

```

### simple\_eap\_fast\_test bob bob

```

EAP-FAST authentication status :
 [0x0e07] TLS authentication succeeded
SUCCESS : Correctly formatted Session Keys received from the server
p01e

```

In this example, the `EAP_FAST` authentication using the PAC from the previous provisioning step succeeded. The `AccessAccept` packet received from Cisco Prime AR can be displayed to confirm that it contains the expected attributes including the MS-MPPE session keys.

## Parameters Used for Certificate-Based Authentication

EAP-FAST might optionally use RSA or ECC certificates to securely create the tunnel that is used for PAC provisioning. However, the Cisco client does not support the use of certificates and the following parameters will be ignored and should be left at their default values:

- PrivateKeyPassword
- ServerCertificateFile
- ServerKeyFile
- CACertificateFile
- CACertificatePath
- ClientVerificationMode
- VerificationDepth
- UseECCCertificates
- EnableSessionCache

- SessionTimeout

The parameters for configuring certificate-based operation are identical to those used for PEAP and EAP-TLS.

Table 9-4 describes the parameters used for certificate-based authentication.

**Table 9-4 Certificate-Based Authentication Parameters**

| Parameter             | Description                                                                                                                                                                                                                                                                                                                        |
|-----------------------|------------------------------------------------------------------------------------------------------------------------------------------------------------------------------------------------------------------------------------------------------------------------------------------------------------------------------------|
| AuthorityIdentifier   | A string that uniquely identifies the credential (PAC) issuer. The client uses this value to select the correct PAC to use with a particular server from the set of PACs it might have stored locally. Care should be taken to ensure that the AuthorityIdentifier is globally unique, that is, is distinct from other PAC issuers |
| AuthorityInformation  | A string that provides some descriptive text for this credential issuer. The value can be displayed to the client for identification purposes. It can contain the enterprise and/or server names.                                                                                                                                  |
| MaximumMessageSize    | Indicates the maximum length in bytes that a EAP-FAST message can have before it is fragmented. If certificates are not used for authentication, fragmentation should not be an issue.                                                                                                                                             |
| AuthenticationTimeout | Indicates the maximum number of seconds before an authentication operation times out and is rejected.                                                                                                                                                                                                                              |
| CredentialLifetime    | Specifies the maximum lifetime of a PAC (Protected Access Credential). Clients that successfully authenticate with an expired PAC will be reprovisioned with a new PAC.                                                                                                                                                            |
| AuthenticationService | Specifies the name of the EAP-GTC service that is used for authentication. The named service must have the UseLabels parameter set to True.                                                                                                                                                                                        |
| ProvisionMode         | Specifies the TLS mode that is used for provisioning. As of this writing, clients only support the default Anonymous mode.                                                                                                                                                                                                         |
| ProvisionService      | Specifies the name of the EAP-MSChapV2 service that is used for provisioning.                                                                                                                                                                                                                                                      |
| AlwaysAuthenticate    | Indicates whether provisioning should always automatically rollover into authentication without relying on a separate session. Most environments, particularly wireless, will perform better when this parameter is set to True (the default value).                                                                               |

## radclient Command Reference

This section describes the **radclient** commands you can use to test EAP-FAST.

### eap-trace

Use the **eap-trace** command to display additional client protocol trace information for EAP methods. Level is a number from 1 to 5 inclusively. Level 5 shows detailed hex dumps of all messages, level 4 shows a message trace without hex dumps, and levels 3 and below show status and error information. To turn off trace displays, set the level to 0.

Set the trace level for all EAP methods.

**eap-trace level**

For example, the following command sets the trace level to 4 for all EAP methods.

```
eap-trace 4
```

Set the trace level for the specified EAP method.

```
eap-trace method level
```

The following example sets the trace level to 5 for EAP-FAST only. The trace level for other EAP methods is not affected.

```
eap-trace eap-fast 5
```



**Note**

---

The **eap-trace** command is for client-side trace information only and is independent of the server trace level that can be set using **aregcmd**.

---

## tunnel

The **tunnel** command is used to specify the inner provisioning and authentication methods for EAP-FAST. The specified EAP method type must agree with the server's configured methods or authentication will fail.

```
tunnel eap-method
```

For EAP-FAST provisioning, the only allowable tunnel method is eap-mchapv2. For EAP-FAST authentication, the only allowable tunnel method is eap-gtc.

## simple\_eap\_fast\_test

The arguments are passed to the inner authentication method as its authentication parameters. If a PAC is not present, the tunnel method should be eap-mschapv2 and provisioning will occur. If a PAC is present, the tunnel method should be eap-gtc and authentication will occur.

```
simple_eap_fast_test username password
```

There are also variants for the **simple** test command for other EAP methods as shown in the following examples:

```
simple_eap_mschapv2_test bob bob
```

```
simple_eap_gtc_test bob bob
```

## pac

The **pac** command is used display, save, and delete PACs that are received from the server during testing. **radclient** maintains a cache of PACs that it knows about and that can be used for authentication testing. The current PAC cache can be displayed with the **pac show** command. PACs created during a test session can be stored to files with the **pac save** command, and reloaded in another session with the **pac load** command. The contents of the PAC cache are completely deleted with **pac delete**. If the optional parameter cache is included, PACs are also erased from disk.

```
pac load | save | show { hex } | delete { cache }
```

The **pac show** command displays the currently cached PACs. If the optional parameter *hex* is included, additional detailed information including hex dumps are included in the display output.

```
pac show { hex }
```

The **pac load** command loads any previously saved PACs from disk into the active cache.

The **pac save** command saves all PACs from the active cache to disk. Any previously existing PACs for the same user will be over-written.

The **pac delete** command deletes all PACs from the active cache. If the optional cache parameter is included then PACs are also erased from disk.

```
pac delete { cache }
```

## PAC—Credential Export Utility

You can manually provision EAP-FAST PACs to clients and avoid the use of the protocol provisioning phase. This might be desirable from a security perspective since the default provisioning protocol uses an anonymous (unauthenticated) method to construct the tunnel used to download the PAC to the client.

Manual provisioning involves exporting a PAC from Cisco Prime AR to a file which is then copied to the client machine and used by the import utility. After a PAC has been manually imported, the client should be able to authenticate via EAP-FAST while bypassing the initial provisioning phase. Care should be taken while storing and transporting PAC files since they contain information that potentially allows a client to authenticate via EAP-FAST.

PACs are exported from Cisco Prime AR via the **pac** command which is a new utility for this release. (Note that this **pac** command is a standalone executable which is different from the Radclient **pac** command.) The **pac** command has two capabilities:

- Exports a PAC to a file
- Displays information about an existing PAC file

### PAC Export

Use the **pac export** command to create a new PAC file. In the following example, *eap-fast* is the name of the Cisco Prime AR service configured for EAP-FAST authentication, *bob* is the name of the user this PAC will be used for, and *password* is the password used to derive a key for encrypting the resulting file. (This password is not the same as the administrator's password). The PAC file will be named **bob.pac** by default. You can use the **-f** option to give the file a different name.

```
pac -s export eap-fast bob password
```

If you omit the password parameter, a default password will be used.

**Note**

---

Using the default password is strongly discouraged for security reasons.

---

## PAC Display

Use the **pac show** command to display information about a PAC file. In the following example, **bob.pac** is the name of the PAC file and *password* is the password used to decrypt the file contents.

```
pac -s show bob.pac password
```

## Syntax Summary

The complete **pac** command syntax is as follows:

```
pac { options } export <service-name> <user-name> <file-password>
```

```
pac { options } show <file-name> file-<password>
```

Where:

- C <cluster>—Specifies the cluster to be used.
- N <user>—Specifies the user.
- P <user-password>—Specifies the password to be used.
- s —Logs in using defaults
- v—Enables verbose output
- f—Exports file name (default = {user-name}.pac)

## EAP-GTC

EAP-GTC, defined in RFC 2284, is a simple method for transmitting a user's name and password to an authentication server. EAP-GTC should not be used except as an authentication method for PEAP Version 1 because the password is not protected.

This section contains the following topics:

- [Configuring EAP-GTC](#)
- [Testing EAP-GTC with radclient](#)

## Configuring EAP-GTC

[Table 9-5](#) lists and describes the EAP-GTC specific properties for EAP-GTC authentication.

**Table 9-5** EAP-GTC Properties

| Property    | Description                                                                           |
|-------------|---------------------------------------------------------------------------------------|
| UserService | Required; name of service that can be used to authenticate using cleartext passwords. |



**Table 9-5 EAP-GTC Properties (continued)**

| Property   | Description                                                                                                                                                                                            |
|------------|--------------------------------------------------------------------------------------------------------------------------------------------------------------------------------------------------------|
| UserPrompt | Optional string the client might display to the user; default is Enter password:” Use the <b>set</b> command to change the prompt, as in the following:<br><br><b>set UserPrompt “Admin Password:”</b> |
| UseLabels  | Required; must be set to TRUE for EAP-FAST authentication and set to FALSE for PEAP authentication. Set to FALSE by default.                                                                           |

To enable EAP-GTC, use **aregcmd** to create and configure a service of type *eap-gtc*

**Step 1** Launch **aregcmd** and create an EAP-GTC service.

```
cd /Radius/Services
add eap-gtc-service
```

**Step 2** Change directory to the service and set its type to eap-gtc.

```
cd eap-gtc-service
set type eap-gtc
```

The follow example shows the default configuration for an EAP-GTC service:

```
[//localhost/Radius/Services/eap-gtc-service]
Name = eap-gtc
Description =
Type = eap-gtc
IncomingScript~ =
OutgoingScript~ =
AuthenticationTimeout = 120
UserService =
UserPrompt = "Enter password:"
UseLabels = False
```

**Step 3** Set the service’s UserService to local-users or another local authentication service that is able to authenticate using clear-text passwords.

```
set UserService local-users
```

**Step 4** If configuring for EAP-FAST, set the UseLabels property to TRUE.

## Testing EAP-GTC with radclient

To test the EAP-GTC service, launch **radclient** and use the **simple\_eap\_gtc\_test** command. The **simple\_eap\_gtc\_test** command sends an Access-Request for the designated user with the user’s password.

The response packet should indicate an Access-Accept if authentication was successful. View the response packet to ensure the authentication was successful.

#### **simple\_eap\_gtc\_test bob bob**

```
Packet: code = Access-Accept, id = 2, length = 104, attributes =
 Service-Type = Framed
 Framed-Protocol = PPP
 Framed-IP-Address = 192.168.0.0
 Framed-IP-Netmask = 255.255.255.0
 Framed-Routing = None
 Framed-MTU = 1500
 Framed-Compression = VJ TCP/IP header compression
 Framed-IPX-Network = 1
 EAP-Message = 03:01:00:04
 Ascend-Idle-Limit = 1800
 Message-Authenticator = d3:4e:b1:7e:2d:0a:ed:8f:5f:72:e0:01:b4:ba:c7:e0
```

## EAP-LEAP

Cisco Prime AR supports the new AAA Cisco-proprietary protocol called Light Extensible Authentication Protocol (LEAP), a proprietary Cisco authentication protocol designed for use in IEEE 802.11 wireless local area network (WLAN) environments. Important features of LEAP include:

- Mutual authentication between the network infrastructure and the user
- Secure derivation of random, user-specific cryptographic session keys
- Compatibility with existing and widespread network authentication mechanisms (e.g., RADIUS)
- Computational speed



#### **Note**

Cisco Prime AR supports a subset of EAP to support LEAP. This is not a general implementation of EAP for Cisco Prime AR.

The Cisco-Wireless or Lightweight Extensible Authentication Protocol is an EAP authentication mechanism where the user password is hashed based on an MD4 algorithm and verified by a challenge from both client and server.

## Configuring EAP-LEAP

You can use **aregcmd** to create and configure a service of type **eap-leap**. When you create an EAP-LEAP service type, you must also specify a UserService to perform AAA service. The UserService can be any configured authentication service.

To enable EAP-LEAP:

**Step 1** Launch **aregcmd** and create an EAP-LEAP service.

```
cd /Radius/Services
```

```
add eap-leap-service
```

**Step 2** Set the service type to **eap-leap**.

```
cd eap-leap-service
```

```
set type eap-leap
```

```
[//localhost/Radius/Services/eap-leap-service]
Name = newone
Description =
Type =
IncomingScript~ =
OutgoingScript~ =
AuthenticationTimeout = 120
UserService =
```

**Step 3** Set the `UserService` property to a configured authentication service.

---

## EAP-MD5

Cisco Prime AR supports EAP-MD5, or MD5-Challenge, another EAP authentication exchange. In EAP-MD5 there is a CHAP-like exchange and the password is hashed by a challenge from both client and server to verify the password is correct. After verified correct, the connection proceeds, although the connection is periodically re-challenged (per RFC 1994).

## Configuring EAP-MD5

Specify type **eap-md5** when you create an EAP-MD5 service. When you create an EAP-MD5 service type, you must also specify a `UserService` to perform AAA service. The `UserService` can be any configured authentication service.

You can use **aregcmd** to create and configure a service of type **eap-md5**. When you create an EAP-MD5 service type, you must also specify a `UserService` to perform AAA service. The `UserService` can be any configured authentication service.

To enable EAP-MD5:

---

**Step 1** Launch **aregcmd** and create an EAP-LEAP service.

```
cd /Radius/Services
```

```
add eap-md5-service
```

**Step 2** Set the service type to **eap-md5**.

```
cd eap-md5-service
```

```
set type eap-md5
```

```
[//localhost/Radius/Services/eap-md5-service]
Name = newone
Description =
Type =
IncomingScript~ =
```

```

OutgoingScript~ =
AuthenticationTimeout = 120
UserService =

```

**Step 3** Set the `UserService` property to a configured authentication service.

---

## EAP-Negotiate

EAP-Negotiate is a special service used to select at runtime the EAP service to be used to authenticate the client. EAP-Negotiate is configured with a list of candidate EAP services that represent the allowable authentication methods in preference order. When an EAP session begins, the EAP-Negotiate service tries the first service in the list. If the client does not support that method, it will respond with an EAP-Nak message which triggers EAP-Negotiate to try the next method on the list until a valid method is found or the list is exhausted in which case authentication fails.

EAP-Negotiate is useful when the client population has deployed a mix of different EAP methods that must be simultaneously supported by Cisco Prime AR. It can be difficult or impossible to reliably distinguish which clients require which methods simply by examining RADIUS attributes or other packet properties. EAP-Negotiate solves this problem by using the method negotiation feature of the EAP protocol. Negotiation can be used to select the primary EAP method used for authentication and also to select the inner method for PEAP.

This section contains the following topics:

- [Configuring EAP-Negotiate](#)
- [Negotiating PEAP Tunnel Services](#)
- [Testing EAP-Negotiate with radclient](#)

## Configuring EAP-Negotiate

You may first use **aregcmd** to create and configure the EAP services that will be used for authentication, then create and configure a service of type `eap-negotiate`.

To enable EAP-Negotiate:

---

**Step 1** Launch **aregcmd** and create an EAP-LEAP service.

```

cd /Radius/Services
add eap-negotiate-service

```

**Step 2** Set the service type to **eap-negotiate**.

```

cd eap-negotiate-service
set type eap-negotiate

[//localhost/Radius/Services/negotiate]
Name = negotiate
Description =
Type = eap-negotiate
IncomingScript~ =

```

```
OutgoingScript~ =
AuthenticationTimeout = 120
ServiceList =
```

**Step 3** Set the ServiceList property to a list of preconfigured EAP authentication services.

The ServiceList property lists the names of the EAP services that can be negotiated with this instance of EAP-Negotiate. The ServiceList property is a space-separated list and must consist of valid EAP service name, *not service types*, in preference order from left to right. Each service and type on the list must be unique; duplicates are not allowed.

```
set ServiceList "eap-leap-service eap-md5-service peap-v1-service"
```

---

## Negotiating PEAP Tunnel Services

EAP-Negotiate can also be used to negotiate the inner tunnel service used for phase two of PEAP-V0 or PEAP-V1. To do this, create and configure a service of type eap-negotiate. The ServiceList can only contain services that are legal for the version of PEAP that it is used with. Set the PEAP service's TunnelService parameter to the name of the eap-negotiate service.



### Note

Not all supplicants support negotiation of the PEAP inner method. EAP-Negotiate can only be used with supplicants that can use EAP-Nak to reject an unsupported inner method.

---

## Testing EAP-Negotiate with radclient

You can test EAP-Negotiate using the same **radclient** commands used to test the other EAP services. For example, you can use the commands for testing eap-leap and peap-v1.

## EAP-MSChapV2

EAP-MSChapv2 is based on **draft-kamath-pppext-eap-mschapv2-00.txt**, an informational IETF draft document. EAP-MSChapv2 encapsulates the MSChapV2 protocol (specified by RFC 2759) and can be used either as an independent authentication mechanism or as an inner method for PEAP Version 0 (recommended).

This section contains the following topics:

- [Configuring EAP-MSChapV2](#)
- [Testing EAP-MSChapV2 with radclient](#)

## Configuring EAP-MSChapV2

To enable EAP-MSChapv2, use **aregcmd** to create and configure a service of type *eap-mschapv2*

---

**Step 1** Launch **aregcmd** and create an EAP-MSChapV2 service.

```
cd /Radius/Services
add eap-mschapv2
```

**Note**

---

This example named the service eap-mschapv2, but you can use any valid name for your service.

---

**Step 2** Set the service's type to eap-mschapv2.

```
cd eap-mschapv2
set Type eap-mschapv2
```

```
[//localhost/Radius/Services/eap-mschapv2]
Name = eap-mschapv2
Description =
Type = eap-mschapv2
IncomingScript~ =
OutgoingScript~ =
AuthenticationTimeout = 120
UserService =
SystemID =
```

**Step 3** Set the service's UserService to local-users or another local authentication service that is able to authenticate using MSChapV2.

```
set UserService local-users
```

**Step 4** You might (optionally) set a string for System ID that identifies the sender of the MSChapV2 challenge message, as in the following:

```
set SystemID system_ID_string
```

---

## Testing EAP-MSChapV2 with radclient

To test the EAP-MSChapVersion 2 service using **radclient**:

---

**Step 1** Launch **radclient**.

**Step 2** Use the **simple\_eap\_mschapv2\_test** command to authenticate using EAP-MSChapV2, as in the following:

```
simple_eap_mschapv2_test bob bob
```

```
p006
```

The **simple\_eap\_mschapv2\_test** command above sends an Access-Request for user bob with the user's password. The response packet should indicate an Access-Accept if authentication was successful.

**Step 3** View the response packet to ensure the authentication was successful.

```
p006
```

```
Packet: code = Access-Accept, id = 4, length = 104, attributes =
```

```

Service-Type = Framed
Framed-Protocol = PPP
Framed-IP-Address = 192.168.0.0
Framed-IP-Netmask = 255.255.255.0
Framed-Routing = None
Framed-MTU = 1500
Framed-Compression = VJ TCP/IP header compression
Framed-IPX-Network = 1
EAP-Message = 03:01:00:04
Ascend-Idle-Limit = 1800
Message-Authenticator = 27:90:7e:20:78:34:43:2e:9d:cd:a8:75:82:53:03:65

```

## EAP-SIM

Cisco Prime AR supports EAP-SIMv16. In a GSM network a subscriber is issued a *smart card* called the subscriber identity module (SIM) that contains a secret key (Ki) and an International Mobile Subscriber Identity (IMSI). The key (Ki) is also stored in the GSM authentication center located with the Home Location Registry (HLR).

An access point uses the Cisco Prime AR RADIUS server to perform EAP-SIM authentication of mobile clients. Cisco Prime AR must obtain authentication information from the HLR. Cisco Prime AR contacts the MAP gateway that performs the MAP protocol over SS7 to the HLR, see [SIGTRAN-M3UA](#) for more information.

In support of EAP-SIM, the Wx Interface feature will be supported. For more information on Wx Interface Support, see the [Wx Interface Support for SubscriberDB Lookup](#), page 17-48.

## Configuring EAP-SIM

You can use **aregcmd** to create and configure a service of type *eap-sim*.

[Table 9-6](#) lists and describes the EAP-SIM specific properties.

**Table 9-6** EAP-SIM Service Properties

| Property              | Description                                                                                                                                                                                                                                                                                           |
|-----------------------|-------------------------------------------------------------------------------------------------------------------------------------------------------------------------------------------------------------------------------------------------------------------------------------------------------|
| AlwaysRequestIdentity | When True, enables the server to obtain the subscriber's identity via EAP/AKA messages instead of relying on the EAP messages alone. This might be useful in cases where intermediate software layers can modify the identity field of the EAP-Response/Identity message. The default value is False. |
| EnableIdentityPrivacy | When True, the identity privacy feature is enabled. The default value is False.                                                                                                                                                                                                                       |

Table 9-6 EAP-SIM Service Properties (continued)

| Property                 | Description                                                                                                                                                                                                                                                                                                                                                                                                                                                                                                                                         |
|--------------------------|-----------------------------------------------------------------------------------------------------------------------------------------------------------------------------------------------------------------------------------------------------------------------------------------------------------------------------------------------------------------------------------------------------------------------------------------------------------------------------------------------------------------------------------------------------|
| PseudonymSecret          | <p>The secret string that is used as the basis for protecting identities when identity privacy is enabled. This should be at least 16 characters long and have a value that is impossible for an outsider to guess. The default value is secret.</p> <p><b>Note</b> It is very important to change PseudonymSecret from its default value to a more secure value when identity privacy is enabled for the first time.</p>                                                                                                                           |
| PseudonymRenewtime       | <p>Specifies the maximum age a pseudonym can have before it is renewed. When the server receives a valid pseudonym that is older than this, it generates a new pseudonym for that subscriber. The value is specified as a string consisting of pairs of numbers and units, where the units might be of the following: M, Minute, Minutes, H, Hour, Hours, D, Day, Days, W, Week, Weeks. The default value is "24 Hours".</p> <p>Examples are: "8 Hours", "10 Hours 30 Minutes", "5 D 6 H 10 M"</p>                                                  |
| PseudonymLifetime        | <p>Specifies the maximum age a pseudonym can have before it is rejected by the server, forcing the subscriber to authenticate using its permanent identity. The value is specified as a string consisting of pairs of numbers and units, where the units might be one of the following: M, Minute, Minutes, H, Hour, Hours, D, Day, Days, W, Week, Weeks. It can also be Forever, in which case, pseudonyms do not have a maximum age. The default value is "Forever".</p> <p>Examples are: "Forever", "3 Days 12 Hours 15 Minutes", "52 Weeks"</p> |
| EnableReauthentication   | <p>When True, the fast reauthentication option is enabled. The default value is False.</p>                                                                                                                                                                                                                                                                                                                                                                                                                                                          |
| MaximumReauthentications | <p>Specifies the maximum number of times a reauthentication identity might be reused before it must be renewed. The default value is 16.</p>                                                                                                                                                                                                                                                                                                                                                                                                        |
| ReauthenticationTimeout  | <p>Specifies the time in seconds that reauthentication identities are cached by the server. Subscribers that attempt to reauthenticate using identities that are older than this value will be forced to use full authentication instead. The default value is 3600 (one hour).</p>                                                                                                                                                                                                                                                                 |
| ReauthenticationRealm    | <p>Optional. If you configure the realm, this value is appended to the FastReauthenticationUserId.</p>                                                                                                                                                                                                                                                                                                                                                                                                                                              |
| AuthenticationTimeout    | <p>Time in seconds to wait for authentication to complete. The default is 2 minutes; range is 10 seconds to 10 minutes.</p>                                                                                                                                                                                                                                                                                                                                                                                                                         |
| QuintetGenerationScript~ | <p>Optional. If the script is set, the custom scripting point can be used to read the quintets from a flat file or generate quintets instead of fetching the quintets from HLR. If the script is not set, the Cisco Prime AR sends the request to HLR configured in remote server to fetch the quintets.</p>                                                                                                                                                                                                                                        |
| UseProtectedResults      | <p>Enables or disables the use of protected results messages. Results messages indicate the state of the authentication but are cryptographically protected.</p>                                                                                                                                                                                                                                                                                                                                                                                    |
| TripletCacheTimeout      | <p>Required; timeout value of triplet cache.</p>                                                                                                                                                                                                                                                                                                                                                                                                                                                                                                    |



**Table 9-6 EAP-SIM Service Properties (continued)**

| Property               | Description                                                                                                                                                                                                                                                                                                                                                                          |
|------------------------|--------------------------------------------------------------------------------------------------------------------------------------------------------------------------------------------------------------------------------------------------------------------------------------------------------------------------------------------------------------------------------------|
| SubscriberDBLookup     | Required. Must be set to either DIAMETER or SIGTRAN-M3UA.<br><br>When set to DIAMETER, the HSS lookup happens using the Diameter Wx Interface. You need to configure the DestinationRealm to send the Diameter packets to the RemoteServer.<br><br>When set to SIGTRAN-M3UA, the HLR/HSS lookup happens using the SIGTRAN protocol. You need to configure the SIGTRAN remote server. |
| FetchAuthorizationInfo | Required. When set True, it fetches MSISDN from HLR.<br><br>This field is displayed when you set Subscriber_DBLookup as SIGTRAN-M3UA.                                                                                                                                                                                                                                                |
| IncomingScript~        | Optional script Cisco Prime AR server runs when it receives a request from a client for an EAP-AKA/EAP-SIM service.                                                                                                                                                                                                                                                                  |
| OutgoingScript~        | Optional script Cisco Prime AR server runs before it sends a response to a client using an EAP-AKA/EAP-SIM service.                                                                                                                                                                                                                                                                  |
| OutageScript~          | Optional. If set to the name of a script, Cisco Prime AR runs the script when an outage occurs. This property allows you to create a script that notifies you when the server detects a failure.                                                                                                                                                                                     |
| RemoteServers          | Remote server which can provide the service.                                                                                                                                                                                                                                                                                                                                         |

To enable EAP-SIM authentication using `argcmd`:

**Step 1** Launch `argcmd` and create an EAP-SIM service.

```
cd /Radius/Services
add eap-sim-service
```

**Step 2** Change directory to the service and set its type to `eap-sim`.

```
cd eap-sim-service
set Type eap-sim

[//localhost/Radius/Services/EAP-SIM]
Name = EAP-SIM
Description =
Type = eap-sim
NumberOfTriplets = 2
UseSimDemoTriplets = False
AlwaysRequestIdentity = False
EnableIdentityPrivacy = False
PseudonymSecret = <encrypted>
PseudonymRenewtime = "24 Hours"
PseudonymLifetime = Forever
Generate3GPPCompliantPseudonym = False
EnableReauthentication = False
MaximumReauthentications = 16
ReauthenticationTimeout = 3600
ReauthenticationRealm =
```

```

TripletCacheTimeout = 120
AuthenticationTimeout = 120
UseProtectedResults = False
SendReAuthIDInAccept = False
SubscriberDBLookup = SIGTRAN-M3UA
FetchAuthorizationInfo = FALSE
MultipleServersPolicy = Failover
IncomingScript~ =
OutgoingScript~ =
OutageScript~ =
RemoteServers/

[//localhost/Radius/Services/eap-sim-wx]
Name = eap-sim-wx
Description =
Type = eap-sim
NumberOfTriplets = 2
UseSimDemoTriplets = False
AlwaysRequestIdentity = False
EnableIdentityPrivacy = False
PseudonymSecret = <encrypted>
PseudonymRenewtime = "24 Hours"
PseudonymLifetime = Forever
Generate3GPPCompliantPseudonym = False
EnableReauthentication = False
MaximumReauthentications = 16
ReauthenticationTimeout = 3600
ReauthenticationRealm =
TripletCacheTimeout = 120
AuthenticationTimeout = 120
UseProtectedResults = False
SendReAuthIDInAccept = False
SubscriberDBLookup = DIiameter
DestinationRealm = hss.com
PreRequestTranslationScript~ =
PostRequestTranslationScript~ =
PreResponseTranslationScript~ =
PostResponseTranslationScript~

```

**Note**

---

The EAP-SIM property `OutagePolicy` present in earlier versions of Cisco Prime AR is no longer part of the EAP-SIM configuration.

---

To enable EAP-SIM authentication using **radclient**:

---

- Step 1** Create an EAP-SIM service.
- Step 2** Change directory to the service and set its type to `eap-sim`.
- Step 3** Execute the below command in `radclient` to set session keys in the server.

```
simple_eap_sim_test 987456321123654 secret
```

**Note**

---

The IMSI number that is stored in HLR is used for EAP-SIM authentication.

---

**Step 4** Enter the server name in which the session key is created to view the *eap-sim* service details.

### p006

```
Packet: code = Access-Accept, id = 3, length = 207, attributes =
User-Name = 987456321123654
MS-MPPE-Send-Key =
9c:56:e5:36:9f:fe:84:a2:26:16:80:0a:13:74:fb:b7:87:30:00:5c:45:99:ea:78:af:7d:ae:37:0e
:b1:3a:2e:2b:b1:c8:4f:20:39:33:04:eb:dc:ba:27:e7:6f:56:08:21:56
EAP-Message = 03:02:00:04
Cisco-AVPair = auth-algo-type=eap-sim
MS-MPPE-Recv-Key =
8b:27:42:c5:47:79:ce:6a:41:ae:34:1f:15:2f:cf:b8:ee:18:e7:b5:1c:64:41:26:f7:4b:bc:53:bd
:54:57:70:a3:3b:df:78:9e:34:33:47:b3:a2:ff:4e:f1:fe:6f:8f:ee:aa
Message-Authenticator = 45:02:01:97:55:3d:bc:80:34:76:a4:5a:6b:29:ac:bc
```

## EAP-Transport Level Security (TLS)

EAP-Transport Level Security (EAP-TLS), described in RFC 2716, is an authentication method designed to mitigate several weaknesses of EAP. EAP-TLS leverages TLS, described in RFC 2246, to achieve certificate-based authentication of the server and (optionally) the client. EAP-TLS provides many of the same benefits as PEAP but differs from it in the lack of support for legacy authentication methods.

This section contains the following topics:

- [Configuring EAP-TLS](#)
- [Testing EAP-TLS with RSA or ECC Certificate using radclient](#)
- [Testing EAP-TLS with Client Certificates](#)

## Configuring EAP-TLS

You can use **aregcmd** to create and configure a service of type *eap-tls*. [Table 9-7](#) describes the EAP-TLS configuration properties:

**Table 9-7** EAP-TLS Service Properties

| Property           | Description                                                                                             |
|--------------------|---------------------------------------------------------------------------------------------------------|
| IncomingScript     | Optional script Cisco Prime AR server runs when it receives a request from a client for EAP-TLS service |
| OutgoingScript     | Optional script Cisco Prime AR server runs before it sends a response to a client using EAP-TLS         |
| MaximumMessageSize | Indicates the maximum length in bytes that a PEAP or EAP-TLS message can have before it is fragmented.  |
| PrivateKeyPassword | The password used to protect the server's private key.                                                  |

Table 9-7 EAP-TLS Service Properties (continued)

| Property              | Description                                                                                                                                                                                                                                                                                                                                                                                                                                                                                                                                                                                                                                                                                                                                                                                                                                                                                                                                                                                                                                                                                                                                          |
|-----------------------|------------------------------------------------------------------------------------------------------------------------------------------------------------------------------------------------------------------------------------------------------------------------------------------------------------------------------------------------------------------------------------------------------------------------------------------------------------------------------------------------------------------------------------------------------------------------------------------------------------------------------------------------------------------------------------------------------------------------------------------------------------------------------------------------------------------------------------------------------------------------------------------------------------------------------------------------------------------------------------------------------------------------------------------------------------------------------------------------------------------------------------------------------|
| ServerCertificateFile | The full pathname of the file containing the server's certificate or certificate chain used during the TLS exchange. The pathname can be optionally prefixed with a special string that indicates the type of encoding used for the certificate. The two valid encoding prefixes are PEM and DER. If an encoding prefix is not present, the file is assumed to be in PEM format.                                                                                                                                                                                                                                                                                                                                                                                                                                                                                                                                                                                                                                                                                                                                                                     |
| ServerKeyFile         | <p>The full pathname of the file containing the server's RSA or ECC private key. The pathname can be optionally prefixed with a special string that indicates the type of encoding used for the certificate. The two valid encoding prefixes are "PEM" and "DER". If an encoding prefix is not present, the file is assumed to be in PEM format.</p> <p>The following example assumes that the subdirectory <b>pki</b> under <b>/cisco-ar</b> contains the server's certificate file. The file <b>server-key.pem</b> is assumed to be in PEM format. The file extension <b>.pem</b> is not significant.</p> <p style="text-align: center;"><b>set ServerKeyFile PEM:/cisco-ar/pki/server-key.pem</b></p>                                                                                                                                                                                                                                                                                                                                                                                                                                             |
| CACertificateFile     | The full pathname of the file containing trusted CA certificates used for client verification. The file can contain more than one certificate, but all certificates must be in PEM format. DER encoding is not allowed.                                                                                                                                                                                                                                                                                                                                                                                                                                                                                                                                                                                                                                                                                                                                                                                                                                                                                                                              |
| CACertificatePath     | <p>The name of a directory containing trusted CA certificates (in PEM format) used for client verification. This parameter is optional, and if it is used there are some special preparations required for the directory it references.</p> <p>Each certificate file in this directory must contain exactly one certificate in PEM format. The server looks up the certificate files using the MD5 hash value of the certificate's subject name as a key. The directory must therefore also contain a set of symbolic links each of which points to an actual certificate file. The name of each symbolic link is the hash of the subject name of the certificate.</p> <p>For example, if a certificate file named <b>ca-cert.pem</b> is located in the CACertificatePath directory, and the MD5 hash of the subject name contained in <b>ca-cert.path.pem</b> is 1b96dd93, then a symbolic link named 1b96dd93 must point to <b>ca-cert.pem</b>.</p> <p>If there are subject name collisions such as multiple certificates with the same subject name, each link name must be indexed with a numeric extension as in 1b96dd93.0 and 1b96dd93.1.</p> |
| CRLDistributionURL    | <p>Optional. The URL that Cisco Prime AR should use to retrieve the CRL. You can specify a URL that uses HTTP or LDAP.</p> <p>The following is an example for an HTTP URL:<br/>&lt;http://crl.verisign.com/pca1.1.1.crl&gt;.</p> <p>The following is an example for an LDAP URL:<br/>ldap://209.165.200.225:388/CN=development-CA,CN=acs-westcoast2,CN=CDP,CN=Public Key Services,CN=Services,CN=Configuration,DC=cisco,DC=com</p>                                                                                                                                                                                                                                                                                                                                                                                                                                                                                                                                                                                                                                                                                                                   |

**Table 9-7 EAP-TLS Service Properties (continued)**

| Property               | Description                                                                                                                                                                                                                                                                                                                                                                                                                                                                                                                       |
|------------------------|-----------------------------------------------------------------------------------------------------------------------------------------------------------------------------------------------------------------------------------------------------------------------------------------------------------------------------------------------------------------------------------------------------------------------------------------------------------------------------------------------------------------------------------|
| ClientVerificationMode | Specifies the type of verification used for client certificates. Must be set to one of RequireCertificate, None, or Optional. <ul style="list-style-type: none"> <li>RequireCertificate causes the server to request a client certificate and authentication fails if the client refuses to provide one.</li> <li>None will not request a client certificate.</li> <li>Optional causes the server to request a client certificate but the client is allowed to refuse to provide one.</li> </ul>                                  |
| VerificationDepth      | Specifies the maximum length ( <b>in bytes?</b> ) of the certificate chain used for client verification.                                                                                                                                                                                                                                                                                                                                                                                                                          |
| UseECCCertificates     | Determines the applicability of the authentication mechanism in SmartGrid Solutions, see the <a href="#">Smart Grid Solution Management, page 17-50</a> for more information.<br><br>When UseECCCertificates is set to True, it can use the ECC, RSA, or combination of both certificate for certificate based verification.<br><br>When UseECCCertificates is set to False, it can only use the RSA certificate for certificate based verification. The default location to fetch the certificate file is <b>/cisco-ar/pki</b> . |
| EnableSessionCache     | Specifies whether TLS session caching (fast reconnect) is enabled or not. Set to True to enable session caching; otherwise set to False.                                                                                                                                                                                                                                                                                                                                                                                          |
| SessionTimeout         | If TLS session caching (fast reconnect) is enabled, SessionTimeout specifies the maximum lifetime of a TLS session. Expired sessions are removed from the cache and will require a subsequent full authentication.<br><br>SessionTimeout is specified as a string consisting of pairs of numbers and units, where units might be one of the following: M, Minute, Minutes, H, Hour, Hours, D, Day, Days, W, Week, Weeks, as in the following:<br><br><b>Set SessionTimeout “1 Hour 45 Minutes”</b>                                |
| AuthenticationTimeout  | Mandatory; specifies time (in seconds) to wait before an authentication request times out; defaults to 120.                                                                                                                                                                                                                                                                                                                                                                                                                       |

To enable EAP-TLS authentication:

**Step 1** Launch **aregcmd** and create an EAP-TLS service.

```
cd /Radius/Services
add eap-tls-service
```

**Step 2** Change directory to the service and set its type to eap-tls.

```
cd eap-tls-service
set Type eap-tls
```

```
[//localhost/Radius/Services/eap-tls-service]
Name = eap-tls-service
```

```

Description =
Type = eap-tls
IncomingScript~ =
OutgoingScript~ =
MaximumMessageSize = 1024
PrivateKeyPassword = <encrypted>
ServerCertificateFile = /opt/CSCOar/pki/server-cert.pem
ServerKeyFile = /opt/CSCOar/pki/server-key.pem
CACertificateFile = /opt/CSCOar/pki/root-cert.pem
CACertificatePath = /opt/CSCOar/pki
CRLDistributionURL =
ClientVerificationMode = Optional
VerificationDepth = 4
EnableSessionCache = true
UseECCCertificates = true
SessionTimeout = "5 Minutes"
AuthenticationTimeout = 120

```

**Note**

---

Cisco Prime AR verifies the certificate during the TLS-based authentication. CRL validation is done before accepting a client certificate during the TLS authentication.

---

## Testing EAP-TLS with RSA or ECC Certificate using radclient

To test the EAP-TLS service, launch **radclient** and use the **simple\_eap\_tls\_test** command, as in the following:

```
simple_eap_tls_test arg1
```

The argument is arbitrary for the **simple\_eap\_tls\_test** command and can be anything. You can either select RSA or ECC client certificates using this argument.

## Testing EAP-TLS with Client Certificates

You can test EAP-TLS using client certificates verified by the server during the TLS exchange. The client certificate file and RSA or ECC key file must reside in **/cisco-ar/pki** and be named **client-cert.pem** and **client-key.pem** respectively. Both files must be in PEM format.

## EAP-TTLS

Cisco Prime AR supports the Extensible Authentication Protocol Tunneled TLS (EAP-TTLS). EAP-TTLS is an EAP protocol that extends EAP-TLS. In EAP-TLS, a TLS handshake is used to mutually authenticate a client and server. EAP-TTLS extends this authentication negotiation by using the secure connection established by the TLS handshake to exchange additional information between client and server.

EAP-TTLS leverages TLS (RFC 2246) to achieve certificate-based authentication of the server (and optionally the client) and creation of a secure session that can then be used to authentication the client using a legacy mechanism. EAP-TTLS provides several benefits:

- Industry standard authentication of the server using certificates (TLS)
- Standardized method for session key generation using TLS PRF
- Strong mutual authentication
- Identity privacy
- Fast reconnect using TLS session caching
- EAP message fragmentation
- Secure support for legacy client authentication methods

EAP-TTLS is a two-phase protocol. Phase 1 conducts a complete TLS session and derives the session keys used in Phase 2 to securely tunnel attributes between the server and the client. The attributes tunneled during Phase 2 can be used to perform additional authentication(s) via a number of different mechanisms.

The authentication mechanisms that can be used during Phase 2 include PAP, CHAP, MS-CHAP, MS-CHAPv2, and EAP. If the mechanism is EAP, then several different EAP methods are possible.

The Phase 2 authentication can be performed by the local AAA Server (the same server running EAP-TTLS) or it can be forwarded to another server (known as the home AAA Server). In the latter case, the home server has no involvement in the EAP-TTLS protocol and can be any AAA service that understands the authentication mechanism in use and is able to authenticate the user. It is not necessary for the home server to understand EAP-TTLS.

This section contains the following topics:

- [Configuring EAP-TTLS](#)
- [Testing EAP-TTLS with radclient](#)

## Configuring EAP-TTLS

Configuring EAP-TTLS involves two major tasks:

1. Configuring the TLS parameters used for Phase 1
2. Selecting the Phase 2 authentication methods and specifying whether authentication is performed locally or forwarded to the home server.

If authentication is forwarded, the configuration must include the identity of the remote home server and its shared secret.

You configure EAP-TTLS using the **aregcmd** CLI to create the appropriate services and specify their parameters. Use the **radclient** test tool to confirm that the services have been properly configured and are operational.

## Creating an EAP-TTLS Service

You can use **aregcmd** to create and configure a service of type *eap-ttls*. [Table 9-8](#) describes the EAP-TTLS configuration properties:

**Table 9-8 EAP-TTLS Service Properties**

| Property              | Description                                                                                                                                                                                                                                                                                                                                                                                                                                                                                                                                                                                                                                                                      |
|-----------------------|----------------------------------------------------------------------------------------------------------------------------------------------------------------------------------------------------------------------------------------------------------------------------------------------------------------------------------------------------------------------------------------------------------------------------------------------------------------------------------------------------------------------------------------------------------------------------------------------------------------------------------------------------------------------------------|
| IncomingScript        | Optional script Cisco Prime AR server runs when it receives a request from a client for EAP-TTLS service.                                                                                                                                                                                                                                                                                                                                                                                                                                                                                                                                                                        |
| OutgoingScript        | Optional script Cisco Prime AR server runs before it sends a response to a client using EAP-TTLS.                                                                                                                                                                                                                                                                                                                                                                                                                                                                                                                                                                                |
| MaximumMessageSize    | Indicates the maximum length in bytes that a PEAP or EAP-TLS message can have before it is fragmented.                                                                                                                                                                                                                                                                                                                                                                                                                                                                                                                                                                           |
| PrivateKeyPassword    | The password used to protect the server's private key.                                                                                                                                                                                                                                                                                                                                                                                                                                                                                                                                                                                                                           |
| ServerCertificateFile | The full pathname of the file containing the server's certificate or certificate chain used during the TLS exchange. The pathname can be optionally prefixed with a special string that indicates the type of encoding used for the certificate. The two valid encoding prefixes are PEM and DER. If an encoding prefix is not present, the file is assumed to be in PEM format.                                                                                                                                                                                                                                                                                                 |
| ServerKeyFile         | <p>The full pathname of the file containing the server's RSA or ECC private key. The pathname can be optionally prefixed with a special string that indicates the type of encoding used for the certificate. The two valid encoding prefixes are "PEM" and "DER". If an encoding prefix is not present, the file is assumed to be in PEM format.</p> <p>The following example assumes that the subdirectory <b>pki</b> under <b>/cisco-ar</b> contains the server's certificate file. The file <b>server-key.pem</b> is assumed to be in PEM format. The file extension <b>.pem</b> is not significant.</p> <pre><b>set ServerKeyFile PEM:/cisco-ar/pki/server-key.pem</b></pre> |
| CACertificateFile     | <p>The full pathname of the file containing trusted CA certificates used for client verification. The file can contain more than one certificate, but all certificates must be in PEM format.</p> <p><b>Note</b> DER encoding is not allowed.</p>                                                                                                                                                                                                                                                                                                                                                                                                                                |



Table 9-8 EAP-TTLS Service Properties (continued)

| Property               | Description                                                                                                                                                                                                                                                                                                                                                                                                                                                                                                                                                                                                                                                                                                                                                                                                                                                                                                                                                                                                                                                                                                                                                                                                                                                                                 |
|------------------------|---------------------------------------------------------------------------------------------------------------------------------------------------------------------------------------------------------------------------------------------------------------------------------------------------------------------------------------------------------------------------------------------------------------------------------------------------------------------------------------------------------------------------------------------------------------------------------------------------------------------------------------------------------------------------------------------------------------------------------------------------------------------------------------------------------------------------------------------------------------------------------------------------------------------------------------------------------------------------------------------------------------------------------------------------------------------------------------------------------------------------------------------------------------------------------------------------------------------------------------------------------------------------------------------|
| CACertificatePath      | <p>The name of a directory containing trusted CA certificates (in PEM format) used for client verification. This parameter is optional, and if used, there are some special preparations required for the directory it references.</p> <p>Each certificate file in this directory must contain exactly one certificate in PEM format. The server looks up the certificate files using the MD5 hash value of the certificate's subject name as a key. The directory must therefore also contain a set of symbolic links each of which points to an actual certificate file. The name of each symbolic link is the hash of the subject name of the certificate.</p> <p>For example, if a certificate file named <b>ca-cert.pem</b> is located in the CACertificatePath directory, and the MD5 hash of the subject name contained in <b>ca-cert.path.pem</b> is 1b96dd93, then a symbolic link named 1b96dd93 must point to <b>ca-cert.pem</b>.</p> <p>If there are subject name collisions such as multiple certificates with the same subject name, each link name must be indexed with a numeric extension as in 1b96dd93.0 and 1b96dd93.1.</p> <p>See <a href="#">rehash-ca-certs Utility</a>, page 9-40 for information about how to create the required certificate file hash links.</p> |
| CRLDistributionURL     | <p>Optional. The URL that Cisco Prime AR should use to retrieve the CRL. You can specify a URL that uses HTTP or LDAP.</p> <p>The following is an example for an HTTP URL:<br/>&lt;http://crl.verisign.com/pca1.1.1.crl&gt;.</p> <p>The following is an example for an LDAP URL:<br/>ldap://209.165.200.225:388/CN=development-CA,CN=acs-westcoast2,CN=CDP,CN=Public Key Services,CN=Services,CN=Configuration,DC=cisco,DC=com</p>                                                                                                                                                                                                                                                                                                                                                                                                                                                                                                                                                                                                                                                                                                                                                                                                                                                          |
| ClientVerificationMode | <p>Specifies the type of verification used for client certificates. Must be set to one of RequireCertificate, None, or Optional.</p> <ul style="list-style-type: none"> <li>• RequireCertificate causes the server to request a client certificate and authentication fails if the client refuses to provide one.</li> <li>• None will not request a client certificate.</li> <li>• Optional causes the server to request a client certificate but the client is allowed to refuse to provide one.</li> </ul>                                                                                                                                                                                                                                                                                                                                                                                                                                                                                                                                                                                                                                                                                                                                                                               |
| VerificationDepth      | <p>Specifies the maximum length of the certificate chain used for client verification.</p>                                                                                                                                                                                                                                                                                                                                                                                                                                                                                                                                                                                                                                                                                                                                                                                                                                                                                                                                                                                                                                                                                                                                                                                                  |

**Table 9-8 EAP-TTLS Service Properties (continued)**

| <b>Property</b>       | <b>Description</b>                                                                                                                                                                                                                                                                                                                                                                                                                                                                                                                      |
|-----------------------|-----------------------------------------------------------------------------------------------------------------------------------------------------------------------------------------------------------------------------------------------------------------------------------------------------------------------------------------------------------------------------------------------------------------------------------------------------------------------------------------------------------------------------------------|
| UseECCCertificates    | <p>Determines the applicability of the authentication mechanism in SmartGrid Solutions, see the <a href="#">Smart Grid Solution Management, page 17-50</a> for more information.</p> <p>When UseECCCertificates is set to True, it can use the ECC, RSA, or combination of both certificate for certificate based verification.</p> <p>When UseECCCertificates is set to False, it can only use the RSA certificate for certificate based verification. The default location to fetch the certificate file is <b>/cisco-ar/pki</b>.</p> |
| EnableSessionCache    | <p>Specifies whether TLS session caching (fast reconnect) is enabled or not. Set to True to enable session caching; otherwise set to False.</p>                                                                                                                                                                                                                                                                                                                                                                                         |
| SessionTimeout        | <p>If TLS session caching (fast reconnect) is enabled, SessionTimeout specifies the maximum lifetime of a TLS session. Expired sessions are removed from the cache and require a subsequent full authentication.</p> <p>SessionTimeout is specified as a string consisting of pairs of numbers and units, where units might be one of the following: M, Minute, Minutes, H, Hour, Hours, D, Day, Days, W, Week, Weeks, as in the following:</p> <p style="text-align: center;"><b>Set SessionTimeout “1 Hour 45 Minutes”</b></p>        |
| AuthenticationTimeout | <p>Mandatory; specifies time (in seconds) to wait before an authentication request times out. The default is 120.</p>                                                                                                                                                                                                                                                                                                                                                                                                                   |
| AuthenticationService | <p>Mandatory; specifies the authentication service to use to authenticate users. See <a href="#">Configuring an EAP-TTLS Authentication Service, page 9-35</a> for more information.</p> <p><b>Note</b> The authentication service must exist before you can save the EAP-TTLS service configuration.</p>                                                                                                                                                                                                                               |

To enable EAP-TTLS authentication:

**Step 1** Launch **aregcmd** and create an EAP-TTLS service.

```
cd /Radius/Services
```

```
add eap-ttls-service
```

**Step 2** Change directory to the service and set its type to eap-ttls.

```
cd eap-ttls-service
```

```
set Type eap-ttls
```

```
[//localhost/Radius/Services/eap-ttls-service]
Name = eap-ttls-service
Description =
Type = eap-ttls
IncomingScript~ =
OutgoingScript~ =
MaximumMessageSize = 1024
PrivateKeyPassword = <encrypted>
ServerCertificateFile = /opt/CSCOar/pki/server-cert.pem
ServerKeyFile = /opt/CSCOar/pki/server-key.pem
CACertificateFile = /opt/CSCOar/pki/root-cert.pem
CACertificatePath = /opt/CSCOar/pki
CRLDistributionURL =
ClientVerificationMode = Optional
VerificationDepth = 4
EnableSessionCache = true
UseECCCertificates = true
SessionTimeout = "5 Minutes"
AuthenticationTimeout = 120
```

**Note**

Cisco Prime AR verifies the certificate during the TLS-based authentication. CRL validation is done before accepting a client certificate during the TLS authentication.

## Configuring an EAP-TTLS Authentication Service

The EAP-TTLS service can authenticate users with either a legacy method such as PAP, CHAP, MSCHAP, or MSCHAPv2 or with an EAP method such as EAP-MSCHAPv2 or EAP-GTC. The authentication can be performed by the local server (the same server running EAP-TTLS) or it can be forwarded to a remote AAA Server (the home server for the user's domain).

This section provides examples of several different ways to configure an EAP-TTLS authentication service. The following examples assume that you are using aregcmd and have already created the EAP-TTLS service.

**Note**

After you make a configuration change, you must save the configuration before it can be used.

### Authenticating Local Users with a Legacy Method

You can use a service like the local-users service (created as part of the example configuration) to authenticate users in the local UserList.

```
set AuthenticationService local-users
```

This service can be used to authenticate using PAP, CHAP, MSCHAP, and MSCHAPv2.

### Authenticating Users with EAP-MSChapV2

This example uses a service named eap-mschapv2 for authentication. Attempts to authenticate using any other method than EAP-MSChapV2 (assuming the service type is also eap-mschapv2) will fail.

```
set AuthenticationService eap-mschapv2
```

### Authenticating Users with EAP Negotiate

You can use the EAP-negotiate method to authenticate using more than one EAP type. The following example defines an EAP service named eap-negotiate that can negotiate EAP-MSChapV2 or EAP-GTC then configures an EAP-TTLS service to authenticate using that service.

To configure an EAP-TTLS service to authenticate using eap-negotiate:

- 
- Step 1** Create a service of type *eap-negotiate*.
- ```
cd /Radius/Services
add eap-nego
cd eap-nego
set Type eap-negotiate
set ServiceList "eap-mschapv2 eap-gtc"
```
- Step 2** Configure the EAP-TTLS AuthenticationService.
- ```
cd /Radius/Services/eap-ttls
set AuthenticationService eap-nego
```
- 

### Authenticating Users with Legacy and EAP Methods

You can configure EAP-TTLS to authenticate using both legacy and EAP methods with a Group service using an OR result rule. A configuration like that shown in the following example first attempts to authenticate with the eap-negotiate service. If that fails, the server attempts to authenticate with the local-users service.

To authenticate with the eap-negotiate service;

- 
- Step 1** Create the Group service
- ```
cd /Radius/Services
add local-or-eap
cd local-or-eap
set Type group
set ResultRule OR
cd GroupServices
add 1 eap-negotiate
add 2 local-users
```
- Step 2** Configure the EAP-TTLS AuthenticationService.
- ```
cd /Radius/Services/eap-ttls
set AuthenticationService local-or-eap
```
- 

### Authenticating Using a Remote AAA Server

You can configure an EAP-TTLS service to forward authentication to a remote AAA Server known (or the home server). The following configures a RADIUS service to use a remote server, then configures EAP-TTLS to use that service for authentication.

The first step in the following example configures a remote RADIUS server (aaa-remote) with its IP address and the shared secret that it shares with the local server. You might also specify other important parameters such as ports, timeouts, and maximum number of retries. See [Services, page 4-11](#), for information about configuring RADIUS services.

To configure a remote RADIUS server (aaa-remote) with its IP address and a shared secret:

- 
- Step 1** Configure a remote AAA Server.
- ```
cd /Radius/RemoteServers
add aaa-remote
cd aaa-remote
set Protocol Radius
set IPAddress 10.1.2.3
set SharedSecret secret
```

The following step configures a RADIUS service to use the remote server created in the previous step. You might also configure other important parameters such as the failover strategy. See [Services, page 4-11](#), for information about configuring RADIUS services.

Step 2 Configure an AAA service.

```
cd /Radius/Services
add home
cd home
set Type Radius
cd RemoteServers
add 1 aaa-remote
```

Step 3 Configure the EAP-TTLS AuthenticationService:

```
cd /Radius/Services/eap-ttls
set AuthenticationService home
```

Other configurations are also possible. For example, a group service can be used to perform some authentications locally and forward others to a remote server.

Testing EAP-TTLS with radclient

To test the EAP-TLS service, launch **radclient** and use the **simple_eap_ttls_test** command. The **simple_eap_ttls_test** command has the following syntax:

```
simple_eap_ttls_test identity password { method }
```

Where:

identity is the user's name.

password is the user's password

method is one of: PAP, CHAP, MSChap, MSChapV2, or PEAP.



Note If the method parameter is EAP, the **tunnel** command must be used to specify the EAP method type.

Testing EAP-TTLS Using Legacy Methods

To authenticate a user using EAP-TTLS with PAP:

Step 1 Launch **radclient**.

```
cd /cisco-ar/usrbin
./radclient -s
```

Step 2 Authenticate using EAP-TTLS PAP.

```
simple_eap_tls_test bob bob pap
```

The following commands show how to test the other valid legacy methods.

```
simple_eap_tls_test bob bob chap
simple_eap_tls_test bob bob mschap
simple_eap_tls_test bob bob mschapv2
```

Testing EAP-TTLS Using EAP Methods

The following example uses EAP-TTLS with EAP-MSChapV2 as the Phase 2 method to authenticate a user named bob whose password is bob (from the example configuration). Issue the **tunnel** command to specify the Phase 2 EAP method, then issue the **simple_eap_tls_test** command with eap as a method type.

To authenticate a user using EAP-TTLS with EAP-MSChapV2 as the Phase 2 method:

Step 1 Launch **radclient**

```
cd /cisco-ar/usrbin
./radclient -s
```

Step 2 Authenticate using EAP-TTLS and EAP-MSChapV2.

```
tunnel eap-mschapv2
simple_eap_tls_test bob bob eap
```

To test with a different EAP method, use the **tunnel** command to specify the method as shown in the following command to specify EAP-TLS.

```
tunnel eap-tls
simple_eap_tls_test bob bob eap
```

rehash-ca-certs Utility

The **rehash-ca-certs** utility works with the `CACertificatePath` property and enables you to create the required certificate file hash links (similar to those used with PEAP and EAP-TLS). The **rehash-ca-certs** utility is only used when the server is validating certificates from the client (which is optional and not a common case for EAP-TTLS).

The syntax for the **rehash-ca-certs** utility is:

```
rehash-ca-certs { -v } path1 { path2 ... pathn }
```

Each directory path specified on the command line is scanned by the **rehash-ca-certs** utility for filenames with the **pem** extension (such as **ca-cert.pem**) and the appropriate hash link is created as described above. Before creating links, **rehash-ca-certs** first removes all existing links in the directory, so each invocation creates fresh links. The `-v` option enables verbose output.

The following is an example of the **rehash-ca-certs** utility:

```
./rehash-ca-certs ../pki  
  
start rehashing ../pki  
client-key.pem does not contain a PEM certificate  
finished rehashing
```

The **rehash-ca-certs** utility warns about PEM files that do not contain certificates. On Cisco Prime Access Registrar, intermediate/chained certificates cannot be imported.

To run Cisco Prime AR on Solaris with PEAP authentication:

-
- Step 1** Add both root and intermediate CA in the directory `/opt/CSCOAr/pki` (as configured for `CACertificatePath` in the service `NYU-NetIDs-PEAPService`).
- Step 2** Change the directory to `pki`:
- ```
cd /opt/CSCOAr/pki
```
- Step 3** run `/opt/CSCOAr/bin/rehash-ca-certs`
- Step 4** Stop ARserver and restart.
- 

## radclient Command Reference

This section provides a summary of the **radclient** commands you can use to test PEAP and EAP-TLS. It contains the following topics:

- [eap-trace](#)
- [tunnel](#)



## eap-trace

Use the **eap-trace** command to display additional client protocol trace information for EAP methods. Set the level to a number from 1 to 5 inclusively. Level 5 shows detailed hexadecimal dumps of all messages. Level 4 shows a message trace without hexadecimal dumps. Levels 3 and below show status and error information. To turn off trace displays, set the level to 0.

Use **eap-trace level** to set the trace level for all EAP methods. The following example command sets the trace level to 4 for all EAP methods:

```
eap-trace 4
```

Use **eap-trace method level** to set the trace level for the specified EAP method. The following example command sets the trace level to 5 for PEAP Version0 only. The trace level for other EAP methods is not affected.

```
eap-trace peap-v0 5
```

**Note**

---

The **eap-trace** command is for client-side trace information only and is independent of the server trace level you set using **aregcmd**.

---

## tunnel

Use the **tunnel** command to specify the inner authentication method for PEAP. The specified EAP method type must agree with the server's configured authentication method or authentication will fail.

```
tunnel eap-method
```

For PEAP Version 0, the allowable tunnel methods are EAP-MSCHAPV2 and EAP-SIM. For PEAP Version 1, the allowable tunnel methods are EAP-GTC and EAP-SIM.

```
simple_eap_mschapv2_test username password
```

```
simple_eap_gtc_test username password
```

```
simple_eap_peapv0_test arg1 arg2
```

The arguments are passed to the inner authentication method as its authentication parameters. For EAP-MSChapv2 the arguments are username and password; for EAP-SIM they are IMSI and key.

```
simple_eap_peapv1_test arg1 arg2
```

The arguments are passed to the inner authentication method as its authentication parameters. For EAP-GTC the arguments are username and password; for EAP-SIM they are IMSI and key.

```
simple_eap_tls_test arg1
```

# Protected EAP

Protected EAP (PEAP) is an authentication method designed to mitigate several weaknesses of EAP. PEAP leverages TLS (RFC 2246) to achieve certificate-based authentication of the server (and optionally the client) and creation of a secure session that can then be used to authenticate the client. PEAP provides several benefits:

- Industry standard authentication of the server using certificates (TLS)
- Standardized method for session key generation using TLS PRF
- Strong mutual authentication
- Identity privacy
- Fast reconnect using TLS session caching
- EAP message fragmentation
- Secure support for legacy client authentication methods

Cisco Prime AR supports the two major existing variants of PEAP, PEAP Version 0 (Microsoft PEAP) and PEAP Version 1 (Cisco PEAP). PEAP Version 0 is described in IETF drafts, **draft-kamath-pppext-peapv0-00.txt** and **draft-josefsson-pppext-eap-tls-eap-02.txt**. This version of PEAP can use either EAP-MSChapV2 or EAP-SIM as an authentication method. PEAP Version 1 is described by IETF draft **draft-zhou-pppext-peapv1-00.txt**. PEAP Version 1 can use either EAP-GTC or EAP-SIM as an authentication method.

This section contains the following topics:

- [PEAP Version 0](#)
- [PEAP Version 1](#)

## PEAP Version 0

This section describes configuring PEAP Version 0 and testing it with **radclient**.

### Configuring PEAP Version 0

You can use **aregcmd** to create and configure a service of type *peap-v0*. [Table 9-9](#) describes the PEAP service properties for PEAP Version 0.

**Table 9-9** PEAP Version 0 Service Properties

| Property           | Description                                                                                              |
|--------------------|----------------------------------------------------------------------------------------------------------|
| IncomingScript     | Optional script Cisco Prime AR server runs when it receives a request from a client for PEAP-v0 service. |
| OutgoingScript     | Optional script Cisco Prime AR server runs before it sends a response to a client using PEAP-v0          |
| MaximumMessageSize | Indicates the maximum length in bytes that a PEAP or EAP-TLS message can have before it is fragmented.   |
| PrivateKeyPassword | The password used to protect the server's private key.                                                   |

Table 9-9 PEAP Version 0 Service Properties (continued)

| Property              | Description                                                                                                                                                                                                                                                                                                                                                                                                                                                                                                                                                                                                                                                                                                                                                                                                                                                                                                                                                                                                                                                                                                                                                  |
|-----------------------|--------------------------------------------------------------------------------------------------------------------------------------------------------------------------------------------------------------------------------------------------------------------------------------------------------------------------------------------------------------------------------------------------------------------------------------------------------------------------------------------------------------------------------------------------------------------------------------------------------------------------------------------------------------------------------------------------------------------------------------------------------------------------------------------------------------------------------------------------------------------------------------------------------------------------------------------------------------------------------------------------------------------------------------------------------------------------------------------------------------------------------------------------------------|
| ServerCertificateFile | <p>The full pathname of the file containing the server's certificate or certificate chain used during the TLS exchange. The pathname can be optionally prefixed with a special string that indicates the type of encoding used for the certificate. The two valid encoding prefixes are PEM and DER. If an encoding prefix is not present, the file is assumed to be in PEM format.</p> <p>The following example assumes that the subdirectory <b>pki</b> under <b>/cisco-ar</b> contains the server's certificate file. The file <b>server-cert.pem</b> is assumed to be in PEM format; note that the file extension <b>.pem</b> is not significant.</p> <pre>set ServerCertificateFile PEM:/cisco-ar/pki/server-cert.pem</pre>                                                                                                                                                                                                                                                                                                                                                                                                                             |
| CACertificateFile     | <p>The full pathname of the file containing trusted CA certificates used for client verification. The file can contain more than one certificate, but all certificates must be in PEM format. DER encoding is not allowed.</p>                                                                                                                                                                                                                                                                                                                                                                                                                                                                                                                                                                                                                                                                                                                                                                                                                                                                                                                               |
| CACertificatePath     | <p>The name of a directory containing trusted CA certificates (in PEM format) used for client verification. This parameter is optional, and if it is used there are some special preparations required for the directory it references.</p> <p>Each certificate file in this directory must contain exactly one certificate in PEM format. The server looks up the certificate files using the MD5 hash value of the certificate's subject name as a key. The directory must therefore also contain a set of symbolic links each of which points to an actual certificate file. The name of each symbolic link is the hash of the subject name of the certificate.</p> <p>For example, if a certificate file name <b>ca-cert.pem</b> is located in the CACertificatePath directory, and the MD5 hash of the subject name contained in <b>ca-cert.path.pem</b> is 1b96dd93, then a symbolic link named 1b96dd93 must point to the <b>ca-cert.pem</b> file.</p> <p>If there are subject name collisions such as multiple certificates with the same subject name, each link name must be indexed with a numeric extension as in 1b96dd93.0 and 1b96dd93.1.</p> |
| CRLDistributionURL    | <p>Optional. The URL that Cisco Prime AR should use to retrieve the CRL. You can specify a URL that uses HTTP or LDAP.</p> <p>The following is an example for an HTTP URL:<br/>&lt;http://crl.verisign.com/pca1.1.1.crl&gt;.</p> <p>The following is an example for an LDAP URL:<br/>ldap://209.165.200.225:388/CN=development-CA,CN=acs-westcoast2,CN=CDP,CN=Public Key Services,CN=Services,CN=Configuration,DC=cisco,DC=com</p>                                                                                                                                                                                                                                                                                                                                                                                                                                                                                                                                                                                                                                                                                                                           |

**Table 9-9 PEAP Version 0 Service Properties (continued)**

| Property               | Description                                                                                                                                                                                                                                                                                                                                                                                                                                                                                                                             |
|------------------------|-----------------------------------------------------------------------------------------------------------------------------------------------------------------------------------------------------------------------------------------------------------------------------------------------------------------------------------------------------------------------------------------------------------------------------------------------------------------------------------------------------------------------------------------|
| ClientVerificationMode | <p>Specifies the type of verification used for client certificates. Must be set to one of RequireCertificate, None, or Optional.</p> <ul style="list-style-type: none"> <li>RequireCertificate causes the server to request a client certificate and authentication fails if the client refuses to provide one.</li> <li>None will not request a client certificate.</li> <li>Optional causes the server to request a client certificate but the client is allowed to refuse to provide one.</li> </ul>                                 |
| VerificationDepth      | <p>Specifies the maximum length of the certificate chain used for client verification.</p>                                                                                                                                                                                                                                                                                                                                                                                                                                              |
| UseECCCertificates     | <p>Determines the applicability of the authentication mechanism in SmartGrid Solutions, see the <a href="#">Smart Grid Solution Management, page 17-50</a> for more information.</p> <p>When UseECCCertificates is set to True, it can use the ECC, RSA, or combination of both certificate for certificate based verification.</p> <p>When UseECCCertificates is set to False, it can only use the RSA certificate for certificate based verification. The default location to fetch the certificate file is <b>/cisco-ar/pki</b>.</p> |
| EnableSessionCache     | <p>Specifies whether TLS session caching (fast reconnect) is enabled or not. Set to True to enable session caching; otherwise set to False.</p>                                                                                                                                                                                                                                                                                                                                                                                         |
| SessionTimeout         | <p>If TLS session caching (fast reconnect) is enabled, SessionTimeout specifies the maximum lifetime of a TLS session. Expired sessions are removed from the cache and will require a subsequent full authentication.</p> <p>SessionTimeout is specified as a string consisting of pairs of numbers and units, where units might be one of the following: M, Minute, Minutes, H, Hour, Hours, D, Day, Days, W, Week, Weeks, as in the following:</p> <p style="text-align: center;"><b>Set SessionTimeout “1 Hour 45 Minutes”</b></p>   |
| AuthenticationTimeout  | <p>Mandatory; specifies time (in seconds) to wait before an authentication request times out; defaults to 120.</p>                                                                                                                                                                                                                                                                                                                                                                                                                      |
| TunnelService          | <p>Mandatory; must be the name of an existing EAP-MSCHAPv2 or EAP-SIM service for PEAP Version 0.</p>                                                                                                                                                                                                                                                                                                                                                                                                                                   |
| EnableWPS              | <p>When set to TRUE, enables Windows Provisioning Service (WPS) and provides two other properties, MasterURL and WPSGuestUserProfile. The default value is FALSE.</p>                                                                                                                                                                                                                                                                                                                                                                   |

**Table 9-9 PEAP Version 0 Service Properties (continued)**

| Property            | Description                                                                                                                                                                                                                                                                                                                                                                                                                                           |
|---------------------|-------------------------------------------------------------------------------------------------------------------------------------------------------------------------------------------------------------------------------------------------------------------------------------------------------------------------------------------------------------------------------------------------------------------------------------------------------|
| MasterURL           | When using WPS, specifies the URL of the provisioning server which is modified with the appropriate fragment and sent to the client.                                                                                                                                                                                                                                                                                                                  |
| WPSGuestUserProfile | When using WPS, specifies a profile to be used as a guest user profile; must be a valid profile under <b>/Radius/Profiles</b> .<br><br>This profile is used for guests and users whose account has expired. This profile normally contains attributes denoting the VLAN-id of the guest network (which has the provisioning server alone) and might contain IP-Filters that would restrict the access of the guest (to only the provisioning server). |

To enable PEAP Version 0:

**Step 1** Launch **aregcmd** and create a PEAP Version 0 service.

```
cd /Radius/Services
add peap-v0-service
```

**Step 2** Set the service's type to peap-v0.

```
cd peap-v0-service
set Type peap-v0
```

```
//localhost/Radius/Services/eap-peap-v0-service]
Name = eap-peap-v0-service
Description =
Type = eap-peap-v0
IncomingScript~ =
OutgoingScript~ =
MaximumMessageSize = 1024
PrivateKeyPassword = <encrypted>
ServerCertificateFile = /opt/CSCOar/pki/server-cert.pem
ServerKeyFile = /opt/CSCOar/pki/server-key.pem
CACertificateFile = /opt/CSCOar/pki/root-cert.pem
CACertificatePath = /opt/CSCOar/pki
CRLDistributionURL =
ClientVerificationMode = Optional
VerificationDepth = 4
EnableSessionCache = true
UseECCCertificates = true
SessionTimeout = "5 Minutes"
AuthenticationTimeout = 120
EnableWPS = FALSE
```

**Step 3** Set the service's TunnelService property to the name of an existing EAP-MSCHAPV2 or EAP-SIM service.

```
set TunnelService name_of_EAP-MSCHAPv2_service

or
```

```
set TunnelService name_of_EAP-SIM_service
```

---

**Note**

Cisco Prime AR verifies the certificate during the TLS-based authentication. CRL validation is done before accepting a client certificate during the TLS authentication.

---

## Testing PEAP Version 0 with radclient

To test the PEAP Version 0:

**Step 1** Launch **radclient**.

**Step 2** Specify the inner authentication method, **eap-mschapv2** or **eap-sim**, as in the following.

```
tunnel eap-mschapv2
```

*or*

```
tunnel eap-sim
```

**Step 3** Use the **simple\_eap\_peapv0\_test** command to authenticate using PEAP Version 0, as in the following:

```
simple_eap_peapv0_test arg1 arg2
```

The **simple\_eap\_peapv0\_test** command passes its arguments to the inner authentication mechanism which treats the arguments as either a username and a password (for **eap-mschapv2**) or as an IMSI and a key (for **eap-sim**).

---

The following example tests PEAP Version 0 with EAP-MSCHAPV2 as the inner authentication mechanism using username bob and password bob:

```
tunnel eap-mschapv2
```

```
simple_eap_peapv0_test bob bob
```

The following example tests PEAP Version 0 with EAP-SIM as the inner authentication mechanism using IMSI 1124567891 and key 0112456789ABCDEF:

```
tunnel eap-sim
```

```
simple_eap_peapv0_test 1124567891 0112456789ABCDEF
```

---

## Testing PEAP Version 0 with Client Certificates

You can test PEAP Version 0 using client certificates verified by the server during the TLS exchange. The client certificate file and RSA or ECC key file must reside in **/cisco-ar/pki** and be named **client-cert.pem** and **client-key.pem** respectively. Both files must be in PEM format.

## PEAP Version 1

This section describes configuring PEAP Version 1 and testing it with **radclient**.

### Configuring PEAP Version 1

You can use **aregcmd** to create and configure a service of type *peap-v1*. Table 9-10 describes the PEAP service properties for both PEAP Version 1.

**Table 9-10 PEAP Version 1 Service Properties**

| Property              | Description                                                                                                                                                                                                                                                                                                                                                                                                                                                                                                                                                                                                                                                                                                                                                                                                                                                                                                                                                                                                                                                                                                                                                   |
|-----------------------|---------------------------------------------------------------------------------------------------------------------------------------------------------------------------------------------------------------------------------------------------------------------------------------------------------------------------------------------------------------------------------------------------------------------------------------------------------------------------------------------------------------------------------------------------------------------------------------------------------------------------------------------------------------------------------------------------------------------------------------------------------------------------------------------------------------------------------------------------------------------------------------------------------------------------------------------------------------------------------------------------------------------------------------------------------------------------------------------------------------------------------------------------------------|
| IncomingScript        | Optional script Cisco Prime AR server runs when it receives a request from a client for PEAP-v1 service.                                                                                                                                                                                                                                                                                                                                                                                                                                                                                                                                                                                                                                                                                                                                                                                                                                                                                                                                                                                                                                                      |
| OutgoingScript        | Optional script Cisco Prime AR server runs before it sends a response to a client using PEAP-v1.                                                                                                                                                                                                                                                                                                                                                                                                                                                                                                                                                                                                                                                                                                                                                                                                                                                                                                                                                                                                                                                              |
| MaximumMessageSize    | Indicates the maximum length in bytes that a PEAP or EAP-TLS message can have before it is fragmented.                                                                                                                                                                                                                                                                                                                                                                                                                                                                                                                                                                                                                                                                                                                                                                                                                                                                                                                                                                                                                                                        |
| PrivateKeyPassword    | The password used to protect the server's private key.                                                                                                                                                                                                                                                                                                                                                                                                                                                                                                                                                                                                                                                                                                                                                                                                                                                                                                                                                                                                                                                                                                        |
| ServerCertificateFile | The full pathname of the file containing the server's certificate or certificate chain used during the TLS exchange. The pathname can be optionally prefixed with a special string that indicates the type of encoding used for the certificate. The two valid encoding prefixes are PEM and DER. If an encoding prefix is not present, the file is assumed to be in PEM format.                                                                                                                                                                                                                                                                                                                                                                                                                                                                                                                                                                                                                                                                                                                                                                              |
| CACertificateFile     | The full pathname of the file containing trusted CA certificates used for client verification. The file can contain more than one certificate but all certificates must be in PEM format. DER encoding is not allowed.                                                                                                                                                                                                                                                                                                                                                                                                                                                                                                                                                                                                                                                                                                                                                                                                                                                                                                                                        |
| CACertificatePath     | <p>The name of a directory containing trusted CA certificates (in PEM format) used for client verification. This parameter is optional, and if it is used there are some special preparations required for the directory it references.</p> <p>Each certificate file in this directory must contain exactly one certificate in PEM format. The server looks up the certificate files using the MD5 hash value of the certificate's subject name as a key. The directory must therefore also contain a set of symbolic links each of which points to an actual certificate file. The name of each symbolic link is the hash of the subject name of the certificate.</p> <p>For example, if a certificate file named <b>ca-cert.pem</b> is located in the CACertificatePath directory, and the MD5 hash of the subject name contained in <b>ca-cert.path.pem</b> is 1b96dd93, then a symbolic link named 1b96dd93 must point to the <b>ca-cert.pem</b> file.</p> <p>If there are subject name collisions such as multiple certificates with the same subject name, each link name must be indexed with a numeric extension as in 1b96dd93.0 and 1b96dd93.1.</p> |

Table 9-10 PEAP Version 1 Service Properties (continued)

| Property               | Description                                                                                                                                                                                                                                                                                                                                                                                                                                                                                                                             |
|------------------------|-----------------------------------------------------------------------------------------------------------------------------------------------------------------------------------------------------------------------------------------------------------------------------------------------------------------------------------------------------------------------------------------------------------------------------------------------------------------------------------------------------------------------------------------|
| CRLDistributionURL     | <p>Optional. The URL that Cisco Prime AR should use to retrieve the CRL. You can specify a URL that uses HTTP or LDAP.</p> <p>The following is an example for an HTTP URL:<br/>&lt;http://crl.verisign.com/pca1.1.1.crl&gt;.</p> <p>The following is an example for an LDAP URL:<br/>ldap://209.165.200.225:388/CN=development-CA,CN=acs-westcoast2,CN=CDP,CN=Public Key Services,CN=Services,CN=Configuration,DC=cisco,DC=com</p>                                                                                                      |
| ClientVerificationMode | <p>Specifies the type of verification used for client certificates. Must be set to one of RequireCertificate, None, or Optional.</p> <ul style="list-style-type: none"> <li>RequireCertificate causes the server to request a client certificate and authentication fails if the client refuses to provide one.</li> <li>None will not request a client certificate.</li> <li>Optional causes the server to request a client certificate but the client is allowed to refuse to provide one.</li> </ul>                                 |
| VerificationDepth      | Specifies the maximum length of the certificate chain used for client verification.                                                                                                                                                                                                                                                                                                                                                                                                                                                     |
| UseECCCertificates     | <p>Determines the applicability of the authentication mechanism in SmartGrid Solutions, see the <a href="#">Smart Grid Solution Management, page 17-50</a> for more information.</p> <p>When UseECCCertificates is set to True, it can use the ECC, RSA, or combination of both certificate for certificate based verification.</p> <p>When UseECCCertificates is set to False, it can only use the RSA certificate for certificate based verification. The default location to fetch the certificate file is <b>/cisco-ar/pki</b>.</p> |
| EnableSessionCache     | Specifies whether TLS session caching (fast reconnect) is enabled or not. Set to True to enable session caching; otherwise set to False.                                                                                                                                                                                                                                                                                                                                                                                                |
| SessionTimeout         | <p>If TLS session caching (fast reconnect) is enabled, SessionTimeout specifies the maximum lifetime of a TLS session. Expired sessions are removed from the cache and will require a subsequent full authentication.</p> <p>SessionTimeout is specified as a string consisting of pairs of numbers and units, where units might be one of the following: M, Minute, Minutes, H, Hour, Hours, D, Day, Days, W, Week, Weeks, as in the following:</p> <p style="text-align: center;"><b>Set SessionTimeout “1 Hour 45 Minutes”</b></p>   |
| AuthenticationTimeout  | Mandatory; specifies time (in seconds) to wait before an authentication request times out; defaults to 120.                                                                                                                                                                                                                                                                                                                                                                                                                             |
| TunnelService          | Mandatory; must be the name of an existing EAP-GTC or EAP-SIM service for PEAP Version 0.                                                                                                                                                                                                                                                                                                                                                                                                                                               |



To enable PEAP Version 1:

---

**Step 1** Launch **aregcmd** and create a PEAP Version 1 service.

```
cd /Radius/Services
add peap-v1-service
```

**Step 2** Set the service's type to peap-v1.

```
cd peap-v1-service
set Type peap-v1
```

```
//localhost/Radius/Services/eap-peap-v1-service]
Name = eap-peap-v1-service
Description =
Type = eap-peap-v1
IncomingScript~ =
OutgoingScript~ =
MaximumMessageSize = 1024
PrivateKeyPassword = <encrypted>
ServerCertificateFile = /opt/CSCOar/pki/server-cert.pem
ServerKeyFile = /opt/CSCOar/pki/server-key.pem
CACertificateFile = /opt/CSCOar/pki/root-cert.pem
CACertificatePath = /opt/CSCOar/pki
CRLDistributionURL =
ClientVerificationMode = Optional
VerificationDepth = 4
EnableSessionCache = true
UseECCCertificates = true
SessionTimeout = "5 Minutes"
AuthenticationTimeout = 120
```

**Step 3** Set the service's TunnelService property to the name of an existing EAP-GTC or EAP-SIM service.

```
set TunnelService name_of_EAP-GTC_service

or

set TunnelService name_of_EAP-SIM_service
```

---

## Testing PEAP Version 1 with radclient

To test the PEAP Version 1:

---

**Step 1** Launch **radclient**.

**Step 2** Specify the inner authentication method, EAP-GTC or EAP-SIM, as in the following.

```
tunnel eap-gtc

or

tunnel eap-sim
```

**Step 3** Use the `simple_eap_peapv1_test` command to authenticate using PEAP Version 1, as in the following:

```
simple_eap_peapv1_test arg1 arg2
```

The `simple_eap_peapv1_test` command passes its arguments to the inner authentication mechanism which treats the arguments as either a username and a password (for EAP-GTC) or as an IMSI and a key (for EAP-SIM).

---

## Testing PEAP Version 1 with Client Certificates

You can test PEAP Version 1 using client certificates verified by the server during the TLS exchange. The client certificate file and RSA or ECC key file must reside in `/cisco-ar/pki` and be named `client-cert.pem` and `client-key.pem` respectively. Both files must be in PEM format.

# How to Configure Oracle, Mysql Accounting with the Buffering Option Enabled

Cisco Prime AR provides support for MySQL to query user records from Oracle database using sql interface and enables you to write accounting records into Oracle database. You can use insert, update, and delete queries to

- add new details into database.
- modify the existing details in the database.
- remove the outdated details from the database.

## To Select the SQL Statement in Run Time Accounting

Cisco Prime AR provides support to query user account details from SQL database and enables you to add, delete, and update accounting details into SQL when using Oracle accounting.

You can execute the following SQL statements to perform various actions:

- [Query](#)
- [Insert](#)
- [Update](#)
- [Delete](#)
- [Configuring Oracle, Mysql Accounting](#)

## Query

You can query the accounting details from Oracle by referring this service in `/Radius/DefaultAuthenticationService` and in `/Radius/DefaultAuthorization`.

The following example is an SQL statement used for Authentication and Authorization of the subscribed users. You can use the SQL and MarkerList properties statement to query the selected attributes from Oracle.

```
sql1/
 Name = sql1
 Description =
 Type = query
 SQL = "select password , username from arusers where username = ?"
 ExecutionSequenceNumber = 1
 MarkerList = UserName/SQL_CHAR
```

## Insert

You can insert user details into SQL database by Oracle accounting. This service is used by referring the **/Radius/DefaultAccountingService** or **Accounting-Service** environment variable.

For instance, you can use the following SQL and MarkerList properties statement to insert the selected attributes:

```
sql1/
 Name = sql1
 Description =
 Type = insert
 SQL = "insert into sql_test (username,nas) values (?,?)"
 ExecutionSequenceNumber = 1
 MarkerList = "UserName/SQL_CHAR NAS-Identifier/SQL_CHAR"
```

## Update

You can easily modify the details in an SQL table with the UPDATE statement.

For example, you can use the following SQL and MarkerList properties statement to update the selected attributes:

```
sql2/
 Name = sql2
 Description =
 Type = update
 SQL = "update sql_test set packet='stop' where username=?"
 ExecutionSequenceNumber = 2
 MarkerList = UserName/SQL_CHAR
```

## Delete

You can remove the unnecessary records from SQL database using DELETE statement.

For example, you can use the following SQL and MarkerList properties statement to delete the selected attributes:

```
sql/
 Name = sql
 Description =
 Type =delete
 SQL = "delete from arusers_acct where username=?"
 ExecutionSequenceNumber = 1
 MarkerList = UserName/SQL_CHAR
```

## Configuring Oracle, Mysql Accounting

The following script describes you how to configure Oracle, Mysql accounting with the buffering option enabled:

```
[//localhost/Radius/Services/oracle-acc]
 Name = oracle-acc
 Description =
 Type = oci-accounting
 IncomingScript~ = sql
 OutgoingScript~ =
 OutagePolicy~ = RejectAll
 OutageScript~ =
 MultipleServersPolicy = Failover
 RemoteServers/

[//localhost/Radius/Services/oracle-acc/RemoteServers]
 1. oracle-acc

[//localhost/Radius/RemoteServers/oracle-acc]
 Name = oracle-acc
 Description =
 Protocol = oci-accounting
 ReactivateTimerInterval = 300000
 Timeout = 15
 DataSourceConnections = 8
 ODBCDataSource = oracle
 SNMPTrapIP =
 SNMPTrapPort = 1521
 KeepAliveTimerInterval = 0
 BufferAccountingPackets = TRUE
 MaximumBufferFileSize = "10 Megabytes"
 NumberOfRetriesForBufferedPacket = 3
 BackingStoreEnvironmentVariables =
 UseLocalTimeZone = FALSE
 AttributeList =
 Delimiter =
 SQLDefinition/

[//localhost/Radius/Advanced/ODBCDataSources/oracle]
 Name = oracle
 Description =
 Type = oracle_oci
 UserID = scott
 Password = <encrypted>
 DataBase = ORCL

[//localhost/Radius/Scripts/sql]
 Name = sql
 Description =
 Language = tcl
 Filename = sql.tcl
 EntryPoint = sqltest
 InitEntryPoint =
 InitEntryPointArgs =
```

### Script

The script statements are executed based on the IP address that you specified in the query. Here is a sample script to select the SQL statements.

```
proc sqltest {request response environ} {
```

```

set nas [$request get NAS-Identifier]
if { [string compare $nas 1.1.1.1] == 0 } {
 $enviro put SQL-Sequence "sql1"
 $enviro put BackingStore-Env-Vars "SQL-Sequence"
}
if { [string compare $nas 1.1.1.2] == 0 } {
 $enviro put SQL-Sequence "sql2"
 $enviro put BackingStore-Env-Vars "SQL-Sequence"
}
if { [string compare $nas 1.1.1.3] == 0 } {
 $enviro put SQL-Sequence "sql3"
 $enviro put BackingStore-Env-Vars "SQL-Sequence"
}
if { [string compare $nas 1.1.1.4] == 0 } {
 $enviro put SQL-Sequence "sql4"
 $enviro put BackingStore-Env-Vars "SQL-Sequence"
}
}
}

```

## How Suffix and Prefix Rules Work with Cisco Prime AR

Cisco Prime AR includes several scripts that you can use with the rules. The following are the most commonly used rules:

- Prefix Rule, See [ExecPrefixRule, page 18-17](#) for more information
- Suffix Rule, See [ExecSuffixRule, page 18-18](#) for more information

### Configuring Prefix and Suffix Policies

To configure prefix and suffix policies in Cisco Prime AR in order to provide authentication and authorization services for the subscribed users:

- Step 1** Activate the Policy Engine by configuring **SelectPolicy**. This script explains you how to set a suffix and prefix policy in the grouping list.

```

--> cd selectPolicy/

[//localhost/Radius/Policies/SelectPolicy]
 Name = SelectPolicy
 Description =
 Grouping = suffixrule&prefixrule

```

- Step 2** Run the configuration rules for Prefix and Suffix.

- Step 3** Set Script = ExecSuffixRule in the prefix rule configuration.

```

[//localhost/Radius/Rules]
 Entries 1 to 2 from 2 total entries
 Current filter: <all>

prefixrule/
 Name = prefixrule
 Description =
 Type = radius
 Script~ = ExecPrefixRule
 Attributes/
 Authentication-Service = local-users
 Authorization-Service = local-users

```

```

Delimiters = @#%$/
Prefix = cisco
StripPrefix = no

```

**Step 4** Specify Script = ExecRealmRule in the suffix configuration to scan.

```

suffixrule/
Name = suffixrule
Description =
Type = radius
Script~ = ExecRealmRule
Attributes/
Realm = @cisco.com

```

## CRL Support for Cisco Prime Access Registrar

Cisco Prime AR checks for various certificates for validation purposes in its authentication services. The client sends a certificate along with the access-challenge to Cisco Prime AR. Cisco Prime AR verifies the validity of the certificate and approves the request if the certificate is valid. For certificate validation, Cisco Prime AR uses an advanced verification mechanism, which uses Certificate Revocation Lists (CRLs).

A CRL, which uses the X.509 certification format, is the signed data structure that the certificate authority (CA) issues periodically. It contains a list of the serial numbers and the timestamp of the revoked certificates. These revoked certificates are not valid and Cisco Prime AR rejects any request that comes with these certificates. The CRLs are available in a public repository in Cisco Prime AR.

A certificate can be revoked because of the following reasons:

- Expiration of the validity period.
- Change in the name of the user to whom the certificate is issued.
- Change in the association between the CA and the user.
- Loss of the private key that is associated with the certificate.

Cisco Prime AR uses the Lightweight Dynamic Authentication Protocol (LDAP) and HTTP for validating the certificates using CRL. The **CRLDistributionURL** in the TLS based EAP authentication services, is used for the CRL support in Cisco Prime AR. When you configure this property, Cisco Prime AR fetches the CRL from the specified URL, at the startup. A background thread in Cisco Prime AR keeps track of these CRLs. When any of the CRLs expires, Cisco Prime AR fetches the latest version of CRL using the specified URL. Each CRL contains the information related to its expiry.

Cisco Prime AR places all the CRLs in a CRL store. It uses these CRLs while it does a TLS authentication for certificate validation. During an authentication service, the certificate verifier in Cisco Prime AR checks for the validity of the certificate against the CRL issued by the CA that signed the certificate. It looks for the serial number of the certificate in the list of revoked certificates in the appropriate CRL. If it finds a match in the CRL, it compares the revocation time that is encoded in the CRL against the current time. If the current time is later than the revocation time, Cisco Prime AR considers the certificate invalid.

This section contains the following topics:

- [Configuring Certificate Validation Using CRL](#)
- [Using Intermediate Certificates in Cisco Prime AR](#)

**Note**

Cisco Prime AR uses the **CRLDistributionURL** property in the following services:

**eap-tls**  
**eap-ttls**  
**eap-fast**  
**peap-v0**  
**peap-v1**

## Configuring Certificate Validation Using CRL

Cisco Prime AR uses the **CRLDistributionURL** property for the certificate validation using CRLs. The following shows a sample configuration for the certificate verification using CRLs in Cisco Prime AR:

```
//localhost/Radius/Services/eap-ttls-service]
Name = eap-ttls-service
Description =
Type = eap-ttls
IncomingScript~ =
OutgoingScript~ =
MaximumMessageSize = 1024
PrivateKeyPassword = <encrypted>
ServerCertificateFile = /opt/CSCOar/pki/server-cert.pem
ServerKeyFile = /opt/CSCOar/pki/server-key.pem
CACertificateFile = /opt/CSCOar/pki/root-cert.pem
CACertificatePath = /opt/CSCOar/pki
CRLDistributionURL =
ClientVerificationMode = Optional
VerificationDepth = 4
EnableSessionCache = true
UseECCCertificates = true
SessionTimeout = "5 Minutes"
AuthenticationTimeout = 120
```

Table 9-8 describes the properties in this sample configuration.

## Using Intermediate Certificates in Cisco Prime AR

The `rehash-ca-certs` utility can be used to import intermediate certificates in Cisco Prime AR. See [rehash-ca-certs Utility, page 9-40](#) for information about how to create the required certificate file hash links.

To import intermediate certificates in Cisco Prime AR:

- 
- Step 1** Copy the Root CA, Intermediate CA of the client to a directory.
  - Step 2** Run `/opt/CSCOar/bin/rehash-ca-certs -v <path of the client certificate store>`  
The utility creates the required hash links to maintain the chain between the Root CA certificate and Intermediate CA certificates.
  - Step 3** Set the `CACertificateFile` property in EAP service to the path where Root CA Certificate of the client is stored.
  - Step 4** Restart the Cisco Prime AR server.
-

The following shows an example to import intermediate certificates in Cisco Prime AR:

**Step 1** Copy the Client Root CA and Intermediate CA Certificate in **/cisco-ar/certs/wimax/** directory.

```
cp /tmp/wimax_device_root.pem /cisco-ar/certs/wimax/
cp /tmp/wimax_device_root_ca1.pem /cisco-ar/certs/wimax/
/opt/CSCOar/bin/rehash-ca-certs -v /cisco-ar/certs/wimax/
```

**Step 2** Enter in to aregcmd.

```
/opt/CSCOar/bin/aregcmd -s
```

a. Configure the eap service which uses these client certificates.

```
cd Radius/Services/eap-ttls
```

```
//localhost/Radius/Services/eap-ttls-service]
Name = eap-ttls-service
Description =
Type = eap-ttls
IncomingScript~ =
OutgoingScript~ =
MaximumMessageSize = 1024
PrivateKeyPassword = <encrypted>
ServerCertificateFile = /opt/CSCOar/pki/server-cert.pem
ServerKeyFile = /opt/CSCOar/pki/server-key.pem
CACertificateFile = /opt/CSCOar/pki/root-cert.pem
CACertificatePath = /opt/CSCOar/pki
CRLDistributionURL =
ClientVerificationMode = Optional
VerificationDepth = 4
EnableSessionCache = true
UseECCCertificates = true
SessionTimeout = "5 Minutes"
AuthenticationTimeout = 120
```

```
set CACertificateFile PEM:/opt/CSCOar/pki/wimax_device_root.pem
```

```
Set CACertificateFile PEM:/opt/CSCOar/pki/wimax_device_root.pem
```

**Step 3** Save the configuration.

```
save
```

**Step 4** Restart the arserver.

```
/opt/CSCOar/bin/arserver restart
```





## CHAPTER 10

# Using WiMAX in Cisco Prime Access Registrar

---

Cisco Prime Access Registrar (Cisco Prime AR) supports Worldwide Interoperability for Microwave Access (WiMAX) technology. This feature support in Cisco Prime AR complies with the WiMAX forum NWG\_R1\_V1.3.1-Stage-3 specifications.

This chapter contains the following sections:

- [WiMAX - An Overview](#)
- [WiMAX in Cisco Prime Access Registrar](#)

## WiMAX - An Overview

WiMAX is a standards-based wireless technology that offers high throughput broadband connections over long distances. WiMAX can be used for a number of applications, including “last mile” broadband connections, fixed and mobile cellular service, hotspots and cellular backhaul, and high-speed enterprise connectivity for business. WiMAX is based on the IEEE 802.16d standard for fixed wireless, and the 802.16e standard for mobile wireless. This standard is appealing to customers because it allows mass production of chipsets that reduce CPE costs, ensures multi-vendor interoperability, and reduces investment risk for operators.

The architectural framework of a WiMAX network consists of the Access Service Network (ASN), the Connectivity Service Network (CSN), and a AAA Server. An Access Service Network is a set of network functions that provide radio access to a WiMAX subscriber. The ASN typically provides functions such as network discovery and selection, connectivity service between the MSS and CSN, Radio Resource Management, Multicast and Broadcast Control, Intra-ASN mobility, Paging, and Location Management. The WiMAX architecture consists of both mobile and fixed subscribers, as well as the ASN and CSN.

A CSN is defined as a set of network functions that provide IP connectivity services to the WiMAX subscribers. CSN might comprise network elements such as Routers, Home Agent, AAA proxy/servers, user databases, Policy Servers, Content Service Gateways, Service Selection Gateways, and interworking gateway devices.

The Access Service Network is connected to a home network HCSN (Home Connectivity Service Network) via at least one visited network (Visited Connectivity Service Network VCSN) or intermediate network.

The Visited CSN plays the role of a AAA proxy. During all AAA interaction the VCSN AAA server acts as a RADIUS proxy transporting RADIUS packets between the ASN and the HCSN.

Figure 10-1 describes the network reference model of a typical WiMAX scenario.

Figure 10-1 WiMAX Network Reference Model

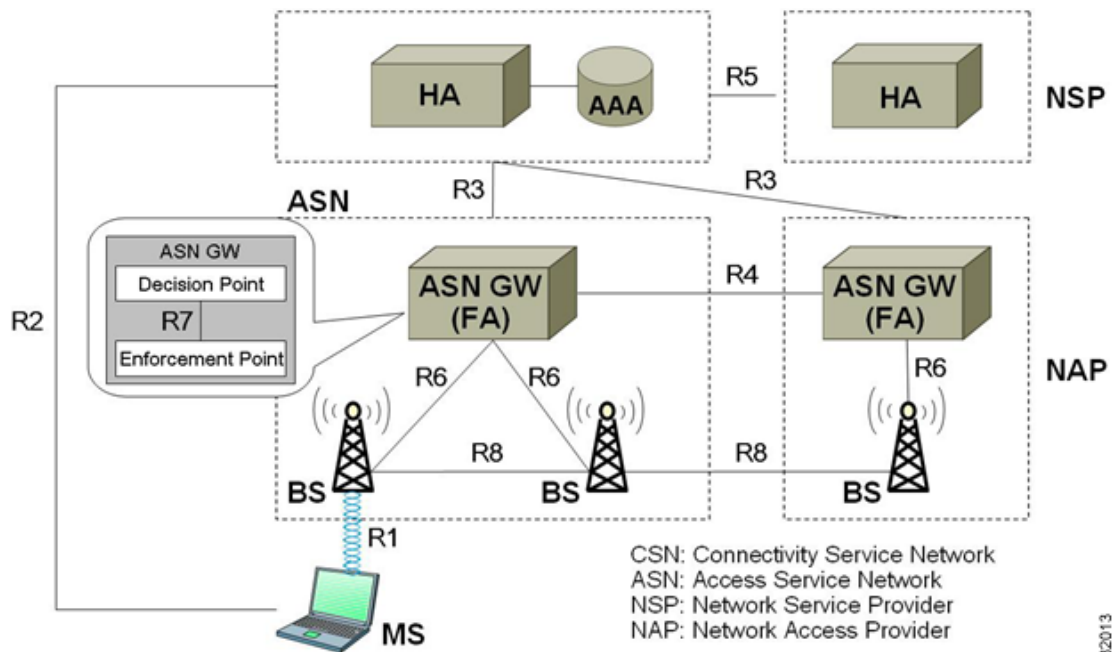

## WiMAX in Cisco Prime Access Registrar

Cisco Prime AR uses the Extensible Authentication Protocol (EAP) to enable the WiMAX feature. It also caches the IP attributes and Mobility Keys that are generated during network access authentication. To enable caching of the WiMAX attributes, you must configure the respective resource managers. See [Configuring the Resource Manager for WiMAX, page 10-7](#), for information on configuring resource manager. Figure 10-2 shows the WiMAX workflow in Cisco Prime AR.

Figure 10-2 WiMAX Workflow

### WIMAX FORUM NWG - Mobile WIMAX NRM ( Network Reference Model )

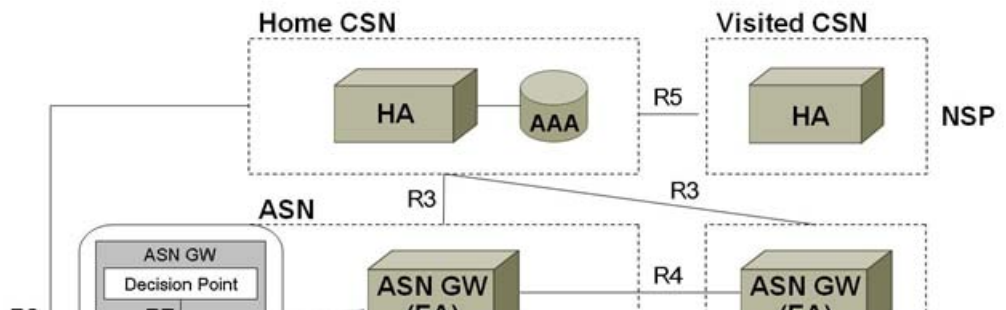

The WiMAX workflow in Cisco Prime AR includes:

- Direct interaction between the ASN GW and Cisco Prime AR
- Interaction between the ASN GW and Cisco Prime AR through the HA

This section contains the following topics:

- [Direct Interaction Between the ASN GW and Cisco Prime Access Registrar](#)
- [Interaction Between ASN GW and Cisco Prime Access Registrar Through HA](#)
- [Prepaid and Hot-Lining](#)

## Direct Interaction Between the ASN GW and Cisco Prime Access Registrar

When the mobile node (MN) sends a RADIUS request to the ASN GW, it forwards this request to the CSN. If it is VCSN, the VAAA proxies the request with Visited HA address in the Access Request to HAAA. The HAAA initiates an authentication using the EAP service, **for example, eap-ttls**. The initial Access-Request containing the WiMAX capability and NAS-Port-Type (Type:61) attributes indicate that the specified flow is for a WiMAX request from ASN GW. Cisco Prime AR redirects this request to the WiMAX service that you configure. The WiMAX service redirects the request to the EAP-based Wimax-Authentication-Service for authentication. Upon successful authentication, the WiMAX service redirects the request to Wimax-Session-Manager to allocate the home agent. Subsequently, Cisco Prime AR generates the appropriate keys based on the Extended Master Session Key (EMSK) and records the generated keys in the session cache resource manager as configured, before sending Access-Accept to the ASN GW.

If there is no VCSN, then the HAAA will send the Access-Accept to ASNGW. Otherwise, the HAAA sends the Access-Accept to VAAA. The VAAA then generates the visited HA-RK Key with SPI and Lifetime and sends the access-accept to ASNGW.

The authentication methods followed by Cisco Prime AR are:

- User-only
- Device-only
- Single-EAP Device or User authentication



---

**Note**

Cisco Prime AR 4.2 does not support Double-EAP authentication.

---

Cisco Prime AR uses the following values to identify the service-type:

- Framed—for initial authentication
- Authenticate-Only—for reauthentication
- Authorize-Only—for prepaid request



---

**Note**

Prepaid attributes can also be sent in the initial authentication.

---

The attributes contained in this flow are listed in [Table 10-1](#). For detailed information on the attributes refer to the WiMAX forum NWG\_R1\_V1.3.1-Stage-3 specifications document.

**Table 10-1**      **Attributes: ASN GW-Cisco Prime AR Flow**

| <b>Attribute</b>                | <b>Description</b>                                                                                                                                                                                                                                                                                                                |
|---------------------------------|-----------------------------------------------------------------------------------------------------------------------------------------------------------------------------------------------------------------------------------------------------------------------------------------------------------------------------------|
| User-Name                       | Must be present. This attribute gets the NAI from the EAP-Response/Identity.                                                                                                                                                                                                                                                      |
| Service-Type                    | Must be present and the value is Framed, Authenticate-Only or Authorize-Only.                                                                                                                                                                                                                                                     |
| WiMAX Capability                | This attribute is chosen by the ASN GW. The request to the Cisco Prime AR is provided through the WiMAX-Capability attribute. The server might respond with the chosen WiMAX Capability.                                                                                                                                          |
| NAS-Port-Type                   | The request must contain this attribute with the value 27. This indicates Wireless IEEE 802.16 port when coming from a WiMAX ASN.                                                                                                                                                                                                 |
| Calling-Station-ID              | The request must contain this attribute with the value set to the MAC address of the device in binary format.                                                                                                                                                                                                                     |
| Device-Authentication-Indicator | The request might contain this attribute to indicate whether the device authentication was performed or not and the result of the action.                                                                                                                                                                                         |
| CUI                             | The NAS might intimate the support for CUI by sending the CUI attribute with the value 'null'.                                                                                                                                                                                                                                    |
| GMT-Time-Zone-Offset            | The request must contain the offsets in seconds from the GMT at the NAS.                                                                                                                                                                                                                                                          |
| Framed-IP-Address               | This is the CMIPv4 Home address to be assigned to the MN. If this attribute is not present then the Home address is derived by the ASN from MIP procedures or through DHCP.                                                                                                                                                       |
| WiMax-Session-ID                | This attribute shall not be present in the initial authentication. The value is a unique identifier in the home realm for this session as set by the HAAA(Cisco Prime AR) in the Access-Accept, when the authentication is successful and it will be included in all subsequent requests from the NAS, such as online accounting. |
| MSK                             | The MSK shall be provided by the AAA Server as a result of successful EAP-authentication.<br><br>MSK can be transmitted using either the MS-MPPE-Keys or the MSK attribute.                                                                                                                                                       |
| Packet-Flow-Descriptor          | The pre-provisioned service flow which might be present in the Access-Accept packet.                                                                                                                                                                                                                                              |
| QoS-Descriptor                  | The pre-provisioned service flow which might be present in the Access-Accept packet, if configured in Cisco Prime AR.                                                                                                                                                                                                             |

**Table 10-1** *Attributes: ASN GW-Cisco Prime AR Flow (continued)*

| Attribute             | Description                                                                                                                                              |
|-----------------------|----------------------------------------------------------------------------------------------------------------------------------------------------------|
| BS-ID                 | Might be present in the Access-Request packet which will identify NAP-ID base station. If both NAP-ID and BS-ID are present, the NAP-ID will be ignored. |
| Acct-Interim-Interval | Sent in the Access-Accept packet. It indicates the accounting update intervals.                                                                          |

Cisco Prime AR generates a few more attributes upon successful authentication. These attributes are described in [Table 10-2](#).

**Table 10-2** *Additional Attributes: ASN-GW Cisco Prime AR Flow*

| Attribute       | Description                                                               |
|-----------------|---------------------------------------------------------------------------|
| hHA-IP-MIP4     | The IP address of the home HA allocated for the incoming request.         |
| vHA-IP-MIP4     | The IP address of the visited HA. To be used by the PMIP4 client.         |
| MN-hHA-MIP4-KEY | The MN-hHA key is used for MIP4 procedures.                               |
| MN-hHA-MIP4-SPI | The SPI associated with the MN-hHA-MIP4-KEY.                              |
| MN-vHA-MIP4-KEY | The MN-vHA key is used for MIP4 procedures.                               |
| MN-vHA-MIP4-SPI | The SPI associated with the MN-vHA-MIP4-KEY.                              |
| FA-RK-KEY       | The FA-RK key will be used at ASN GW to derive MN-FA for MIP4 procedures. |

**Note**

A policy engine can parse the NAI decoration and conclude the type of authentication method for the incoming access-request for passing on to WiMAX service.

## Interaction Between ASN GW and Cisco Prime Access Registrar Through HA

After Cisco Prime AR returns the Access-Accept to the ASN GW, the mobile node, which initially sent the request, sends a registration request to the ASN GW. The ASN GW receives this request and sends an Access-Request to the HA. A Query-Request will be sent to the Cisco Prime AR by HA to receive the security context for authenticating the FA.

Cisco Prime AR identifies the request as HA query request, if:

- the WiMAX mobility attribute is present
- the NAS-Port-Type attribute is absent

Cisco Prime AR checks for a valid session in the session cache based on NAI and sends an Access-Accept to the HA.

**Table 10-3 HAAA Cached Attributes**

| Attribute                     | Description                                                                                                                               |
|-------------------------------|-------------------------------------------------------------------------------------------------------------------------------------------|
| Pseudo Identity               | As received from the MS in the NAI in the EAP-Response/Identity. The HAAA is required to correlate this to the true identity of the user. |
| NAS-ID/NAS-IP address         | One or both of these parameters are cached by the HAAA. This is required to locate the serving NAS.                                       |
| Framed-IP Address             | The IP address allocated to the user session. This information is useful in identifying the session during AAA dynamic procedures.        |
| MIP-RK, hHA-RK, FA-RK, MN-hHA | Mobility keys generated during network access authentication. These keys are cached and used by the network for mobility authentication.  |
| hHA-IP address                | The IP address of the home HA assigned to the MS.                                                                                         |

**Table 10-4 VAAA Cached Attributes**

| Attribute                                   | Description                                                                                                                              |
|---------------------------------------------|------------------------------------------------------------------------------------------------------------------------------------------|
| vHA-RK, vHA-RK-SPI, vHA-RK Lifetime, MN-vHA | Mobility keys generated during network access authentication. These keys are cached and used by the network for mobility authentication. |
| vHA-IP address                              | The IP address of the visited HA assigned to the MS.                                                                                     |

**Note**

Cisco Prime AR responds with the correct keys back to the HA based on the NAI in **User-Name** attribute. Cisco Prime AR returns an Access-Reject if it does not find a valid session for the NAI during the user authentication and authorization or if there are other errors.

## Prepaid and Hot-Lining

Cisco Prime AR supports prepaid and hot-lining flows for WiMAX. These are supported by the existing mechanisms.

## Configuring WiMAX in Cisco Prime Access Registrar

A new service type named **wimax** will be used for the WiMAX feature in Cisco Prime AR. **aregcmd** command is used to configure WiMAX in Cisco Prime AR. WiMAX service contains—Session Manager (with a session-cache resource manager and HA resource manager), Query Service that is connected to the session manager configured for this service, and Prepaid Service, which are required to connect all the flows appearing in Cisco Prime AR for WiMAX. This service will be used as a container for the new key generation modules and the existing modules such as EAP services.

Configuring WiMAX in Cisco Prime AR involves configuration of:

- Resource Manager for WiMAX
- Session Manager for WiMAX
- Query Service for WiMAX
- WiMAX properties

This section contains the following topics:

- [Configuring the Resource Manager for WiMAX](#)
- [Configuring the Session Manager for WiMAX](#)
- [Configuring the Query Service for WiMAX](#)
- [Configuring WiMAX](#)
- [Configuring WiMAX](#)

## Configuring the Resource Manager for WiMAX

You must configure the following two Resource Managers:

- HA (home-agent or home-agent-ipv6)
- HA Cache (session-cache)

The HA Resource Manager must contain the IP ranges covering all the HA IP addresses that are to be assigned in round-robin. You must configure the HA Cache Resource Manager to cache the mobility keys ([Table 10-3](#)).



### Note

The HA Resource Manager allocates the IP addresses to the HA. If you do not configure the HA Resource Manager properly, Cisco Prime AR will not generate some of the keys, which result in an Access-Reject by the NAS.

The following shows the sample configuration for HA:

```
[/Radius/ResourceManagers/HA]
Name = HA
Description =
Type = home-agent
Home-Agent-IPAddresses/
Entries 1 to 1 from 1 total entries
Current filter: <all>
209.165.200.225-209.165.200.254/
```

The following shows the sample configuration for HA Cache in HAAA:

```
[/Radius/ResourceManagers/HA-Cache]
Name = HA-Cache
Description =
Type = session-cache
OverwriteAttributes = TRUE
QueryKey = User-Name
PendingRemovalDelay = 10
AttributesToBeCached/
 1. WiMax-Session-ID
 2. hHA-RK-Key
 3. hHA-RK-SPI
 4. MN-hHA-MIP4-Key
 5. hHA-RK-Lifetime
```

## 6. MIP-RK

The following shows the sample configuration for HA Cache in VAAA:

```
[/Radius/ResourceManagers/HA-Cache]
Name = HA-Cache
Description =
Type = session-cache
OverwriteAttributes = TRUE
QueryKey = User-Name
PendingRemovalDelay = 10
AttributesToBeCached/
 1. vHA-RK-Key
 2. vHA-RK-SPI
 3. MN-vHA-MIP4-Key
 4. vHA-RK-Lifetime
```

When the OverwriteAttributes value is set as TRUE, the newly generated mobility keys will be cached with the session record. By default, the value is FALSE.

The HA-RK-Lifetime attribute type must be of type STRING instead of UINT32 under `/Radius//advanced/attribute\ dictionary/vendor-Specific/vendors/wimax/subAttribute\ Dictionary`.

**Note**

For generating RRQ-MN-HA key, we must configure MIP-RK in the AttributesToBeCached list.

## Configuring the Session Manager for WiMAX

Before configuring WiMAX service, you must configure a session manager for WiMAX with a HA and session cache resource manager. The following shows an example configuration of a session manager with HA and session cache resource managers.

```
[/Radius/SessionManagers/session-mgr-2]
Name = session-mgr-2
Description =
IncomingScript =
OutgoingScript =
AllowAccountingStartToCreateSession = FALSE
SessionTimeOut =
PhantomSessionTimeOut =
SessionKey =
ResourceManagers/
 1. HA-Cache
 2. HA
```

**Note**

If a default session manager is configured with the same key as that of the WiMAX session manager, the incoming WiMAX request will fail.

## Configuring the Query Service for WiMAX

When you configure a query service for the WiMAX service in Cisco Prime AR, you must refer it to the WiMAX Session Manager that you created. While configuring WiMAX, you must refer the **WiMAX-Query-Service** parameter to a valid Query Service.

You must configure the Query key as the **User-Name** attribute, which contains the NAI. You must also configure the query service to return all the relevant mobility keys as described in [Table 10-5](#).



**Table 10-5**      **Mobility Keys**

| Key         | Generated By         | Used At                   |
|-------------|----------------------|---------------------------|
| MN-HA-CMIP4 | MN and HAAA          | HA and MN                 |
| MN-HA-PMIP4 | MN and HAAA          | HA and PMIP4 client       |
| MN-HA-CMIP6 | MN and HAAA          | MN and HA                 |
| FA-RK       | MN and HAAA          | MN and Authenticator      |
| MN-FA       | MN and Authenticator | FA and MN or PMIP4 client |
| HA-RK       | HAAA or VAAA         | HA and Authenticator      |
| FA-HA       | HA and Authenticator | HA and FA                 |

The following shows a sample configuration for a WiMAX Query Service:

```
[../haQueryService]
Name = haQueryService
Description =
Type = radius-query
IncomingScript~ =
OutgoingScript~ =
SessionManagersToBeQueried/
1. session-mgr-2
AttributesToBeReturned/
1. WiMax-Session-ID
2. HA-RK-Key
```

**Note**

If AttributesToBeReturned is not configured, all the cached attributes will be returned.

## Configuring WiMAX

When you configure the WiMAX service under **/Radius/Services**, you must set its type to **wimax** and provide the following configuration options:

```
[//localhost/Radius/Services/wimax]
Name = WiMAX
Description =
Type = WiMAX
IncomingScript~ =
OutgoingScript~ =
OutagePolicy~ = RejectAll
OutageScript~ =
HA-RK-Key = cisco112
HA-RK-LifeTime = 60
WiMAX-Authentication-Service = None
WiMAX-Session-Manager = None
WiMAX-Query-Service = None
WiMAX-Prepaid-Service = None
Allow-HAAA-To-Include-Keys = TRUE
Require-MSK = False
```

The syntax to generate the a WiMAX request from radclient is

**simple\_wimax\_asn\_test bob(username) bob(password)**

**Table 10-6** WiMAX Service Parameters

| Parameter                    | Description                                                                                                                                                                                                                                                   |
|------------------------------|---------------------------------------------------------------------------------------------------------------------------------------------------------------------------------------------------------------------------------------------------------------|
| Name                         | Required; inherited from the upper directory.                                                                                                                                                                                                                 |
| Description                  | An optional description of the service.                                                                                                                                                                                                                       |
| Type                         | Must be set to <b>wimax</b> for WiMAX service.                                                                                                                                                                                                                |
| IncomingScript               | Optional.                                                                                                                                                                                                                                                     |
| OutgoingScript               | Optional.                                                                                                                                                                                                                                                     |
| OutagePolicy                 | Required; must be set to AcceptAll or Drop Packet, or defaults to RejectAll.                                                                                                                                                                                  |
| OutageScript                 | Optional. if you set this property to the name of a script, Cisco Prime AR runs it when an outage occurs. This property allows you to create a script that notifies you when the RADIUS server detects a failure.                                             |
| HA-RK-Key                    | Used as the base key to generate random HA-RK-Key for all the HAs that are configured in Cisco Prime AR.<br><br>By default, the value is <code>cisco112</code> . You can change this value.                                                                   |
| HA-RK-LifeTime               | Used as time (in minutes) to regenerate the HA-RK-Keys based on its lifetime.                                                                                                                                                                                 |
| WiMAX-Authentication-Service | A valid eap service which can be used for WiMAX authentication. By default, this value is <code>none</code> .<br><br>For VAAA, it should be configured with valid radius proxy service.                                                                       |
| WiMAX-Session-Manager        | A valid session manager which has HA and HA Cache as resource managers. By default, this value is <code>none</code> .                                                                                                                                         |
| WiMAX-Query-Service          | A valid RADIUS query service configured with WiMAX session manager. By default, this value is <code>none</code> .                                                                                                                                             |
| WiMAX-Prepaid-Service        | A valid prepaid service can be given to carry out the prepaid functionality of WiMAX. Otherwise this value is set to <code>none</code> .                                                                                                                      |
| Allow-HAAA-To-Include-Keys   | If this is set, the HAAA will include the <code>hHA-RK-Key</code> , <code>hHA-RK-SPI</code> and <code>hHA-RK-Lifetime</code> in the Access-Accept. Otherwise, those attributes will not be in the Access-Accept. By default this value is <code>True</code> . |
| Require-MSK                  | If this is set, the MSK will be provided by the AAA server as a result of successful EAP-Authentication. By default, this value is <code>False</code> .                                                                                                       |

## WiMAX - OMA-DM Provisioning Support with BEK key

In addition to WiMax subscriber authentication, the Cisco Prime AR generates and caches the Bootstrap Encryption Key (BEK) when it receives the authentication request from the unprovisioned WiMax subscriber/device. Cisco Prime AR can identify the unprovisioned device either by looking the special pattern in Access-Request or by performing explicit database lookup.

The BEK key derived from EMSK is calculated as follows:

BEK = the 16 most significant (leftmost) octets of HMAC-SHA256(EMSK, "bek@wimaxforum.org").

When Cisco Prime AR receives the accounting start packet for the unprovisioned device,

1. IP, MAC address, and BEK of the unprovisioned device notifies the OMA-DM server to initiate the provisioning.
2. Cisco Prime AR maintains the IP address to MAC address association using web-service until it receives the provisioning complete message from the OMA-DM server.

The Backend Portal queries the Cisco Prime AR web-service for this unprovisioned device MAC address by giving the device IP address and also the OMA-DM server request the Cisco Prime AR web-service to validate the MAC to IP address association

The communication between Cisco Prime AR and OMA-DM/Portal server is through web-service by using SOAP over HTTPS. It is assumed that the OMA-DM server (or a mediation function) will have a web-service using which AR can communicate.

### Configuring the WiMax-Provisioning

To configure WiMax provisioning:

**Step 1** Configure a script object, such as wimax-provision.

```
[//localhost/Radius/Scripts/wimax-provision]
 Name = wimax-provision
 Description =
 Language = rex

--> set FileName to 'libProvisioning.so'
set FileName /cisco-ar/scripts/radius/rex/libProvisioning.so

--> set EntryPoint 'ProvisionedDeviceLookup'
set EntryPoint ProvisionedDeviceLookup

--> set InitEntryPoint 'InitializeProvisioning'
set InitEntryPoint InitializeProvisioning

--> set InitEntryPointArgs to 'ldap:wimax'
set InitEntryPointArgs ldap:wimax
```

**ls**

```
[//localhost/Radius/Scripts/wimax-provision]
 Name = wimax-provision
 Description =
 Language = rex
 Filename = /cisco-ar/scripts/radius/rex/libProvisioning.so
 EntryPoint = ProvisionedDeviceLookup
```

```
InitEntryPoint = InitializeProvisioning
InitEntryPointArgs = ldap:wimax
```

The file `libProvisioning.so` is come up with Cisco Prime AR kit. You have to copy it into `/cisco-ar/scripts/radius/rex` path. Entrypoint `ProvisionedDeviceLookup` literally looks up a datastore to check if the user is provisioned. `InitEntryPoint 'InitializeProvisioning'` takes care of all initialization work for entry point. `InitEntryPointArgs 'ldap-wimax'` says the user look up to be performed against `ldap` datasotre. Oracle datastore can also be used wherein you have to give this property to `'oracle:wimax'`.

**Step 2** Configure the configured script object to the server's incoming scripting point.

```
set IncomingScript wimax-provision
```

```
ls
```

```
[//localhost/Radius]
Name = Radius
Description =
Version = 5.0.0
IncomingScript~ = provision
OutgoingScript~ =
```

**Step 3** Webclient setup

Create a script object which calls the Cisco Prime AR's `wimax-provisioing` webservice.

```
[//localhost/Radius/Scripts/WebServicecall]
Name = WebServicecall
Description =
Language = rex
Filename = libProvisioning.so
EntryPoint = WebServiceCall
InitEntryPoint =
InitEntryPointArgs =
```

Entry point should be set to `WebServiceCall`.

**Step 4** Save the configuration:

```
save
```

**Step 5** Reload the configuration:

```
reload
```

## WiMax Lawful Interception (LI) Support in Cisco Prime AR

Cisco Prime AR provides support for Intercept Access Point (IAP) for receiving the intercept/monitoring request for the subscriber whose “Access Associated” Communications Identifying Information (AA CmII) is to be intercepted and delivered to a Law Interception Server (LIS).

Cisco Prime AR supports the following intercept request from LIS:

- ProvisionTarget - To start monitoring the target user
- DeprovisionTarget - To stop monitoring the target user
- LinkUpdate - To query the target user in monitored list
- ListTarget – To list all the users that are currently being monitored

#### Initiating Monitoring Process

When the “ProvisionTarget” request is received from LIS, Cisco Prime AR adds the respective user in monitoring list and starts monitoring the user events.

Table 10-7 lists the events of the target user that are reported to LIS:

**Table 10-7 Targeted User Events**

| Events         | Attributes                                                                                                                                                                                                                                                                                                                                                                                                                       |
|----------------|----------------------------------------------------------------------------------------------------------------------------------------------------------------------------------------------------------------------------------------------------------------------------------------------------------------------------------------------------------------------------------------------------------------------------------|
| Access Attempt | <ul style="list-style-type: none"> <li>• Case Identity (M)</li> <li>• IAP System Identity (M)</li> <li>• Time Stamp (M)</li> <li>• Subscriber Identity (M)</li> <li>• Access Method (C)</li> <li>• Network Access Node Identity (C)</li> <li>• Protocol Signal (O)</li> </ul>                                                                                                                                                    |
| Access-Accept  | <ul style="list-style-type: none"> <li>• Case Identity (M)</li> <li>• IAP System Identity (M)</li> <li>• Time Stamp (M)</li> <li>• Subscriber Identity (M)</li> <li>• Access Method (C)</li> <li>• Network Access Node Identity (C)</li> <li>• IP address (C)</li> <li>• Access Session Identity (M)</li> <li>• Access Session Characteristics (C)</li> <li>• Location information (C)</li> <li>• Protocol Signal (O)</li> </ul> |
| Access-Failed  | <ul style="list-style-type: none"> <li>• Case Identity (M)</li> <li>• IAP System Identity (M)</li> <li>• Time Stamp (M)</li> <li>• Subscriber Identity (M)</li> <li>• IP Address (C)</li> <li>• Reason for Termination (C)</li> <li>• Protocol Signal (O)</li> </ul>                                                                                                                                                             |

**Table 10-7 Targeted User Events (continued)**

| Events               | Attributes                                                                                                                                                                                                                                                                                                  |
|----------------------|-------------------------------------------------------------------------------------------------------------------------------------------------------------------------------------------------------------------------------------------------------------------------------------------------------------|
| Access-Session-Start | <ul style="list-style-type: none"> <li>• Case Identity (M)</li> <li>• IAP System Identity (M)</li> <li>• Time Stamp (M)</li> <li>• Subscriber Identity (M)</li> <li>• Access Session Identity (M)</li> <li>• IP Address (C)</li> <li>• Protocol Signal (O)</li> </ul>                                       |
| Access-Session-End   | <ul style="list-style-type: none"> <li>• Case Identity (M)</li> <li>• IAP System Identity (M)</li> <li>• Time Stamp (M)</li> <li>• Subscriber Identity (M)</li> <li>• Access Session Identity (M)</li> <li>• IP Address (C)</li> <li>• Reason for Termination (C)</li> <li>• Protocol Signal (O)</li> </ul> |
| Access-Rejected      | <ul style="list-style-type: none"> <li>• Case Identity (M)</li> <li>• IAP System Identity (M)</li> <li>• Time Stamp (M)</li> <li>• Subscriber Identity (M)</li> <li>• IP address(C)</li> <li>• Reason for Termination(C)</li> <li>• Protocol Signal (O)</li> </ul>                                          |

**Note**

The attribute with (M) represents mandatory, (O) represents optional, (C) represents conditionally available.

**Stopping Monitoring Process**

On receiving the DeprovisionTarget request from LIS, the target user is removed from the monitoring list.

**Querying Target User Events**

On receiving the LinkUpdate request on target user from LIS, the target user details are checked in the monitoring list and message is sent to LIS as listed below:

- If the specified user is not currently being monitored, a reply with reason-code indicating that the user is currently not targeted is sent.
- If the specified user is currently being targeted and is not logged into the network, a reply with status stating that the user is “inactive” in the network is sent.

- If the specified user is currently being targeted and is logged into the network, a reply with the following attributes is sent:
  - Case Identity (M)
  - IAP System Identity (M)
  - Time Stamp (M)
  - Subscriber Identity (M)
  - Access Method (C)
  - Network Access Node Identity (C)
  - IP address (C)
  - Access Session Identity (M)
  - Access Session Characteristics (C)
  - Location information (C)
  - Protocol Signal (O)

### Viewing Monitored Users

On receiving the ListTarget request from LIS, a list of users that are currently being monitored are sent to LIS. The reply will contain a surveillance-target-count attribute indicating the count of the number of users being targeted and multiple instances of surveillance-target-identifier attribute having the real identifiers.

Each request from the LIS contains a transaction-id which is copied on to the reply from Cisco Prime AR. For each request type there is an appropriate response type with appropriate return data. They are as follows:

- ProvisionTargetResult - an acknowledgement for the ProvisionTarget request with the same transaction id
- DeprovisionTargetResult - an acknowledgement for the DeprovisionTarget request with the same transaction id
- LinkUpdateResult - for LinkUpdate, see [Querying Target User Events](#)
- ListTargetResult - for ListTarget, see [Viewing Monitored Users](#)

## Configuring WiMax-Lawful Intercept

Two scripts which are LawfulIntercept and RexLiScript are to be configured to run LawfulIntercept service in Cisco Prime AR. LawfulIntercept script should be configured in the server's incoming scripting point which is used to check the provisioned status of the user in the incoming access request. If the user is provisioned in the data store, Virtual-Server-Outgoing-Script will be executed after the server's outgoingscripting point.

InitEntryPoint of LawfulIntercept script writes the targeted list of users to a file while the server is stopping and reads the targeted users back to data store while the server is starting.

RexLiScript is configured in Virtual-Server-Outgoing-Script that sends events of the provisioned users to the LI service client.

### Configuring the WiMax-Lawful Intercept

To configure WiMax-Lawful Intercept:

**Step 1** Create the RexLiScript script object that will be set in Virtual-Server-Outgoing-Script point.

```
[//localhost/Radius/Scripts/virtual]
 Name = virtual
 Description =
 Language = rex
 Filename = libLiScript.so
 EntryPoint = RexLiScript
 InitEntryPoint = InitRexLiScript
 InitEntryPointArgs =
```

**Step 2** Create the LawfulIntercept script object.

```
[//localhost/Radius/Scripts/LiScript]
 Name = LiScript
 Description =
 Language = Rex
 Filename = libLiScript.so
 EntryPoint = LawfulIntercept
 InitEntryPoint = RexInitialize
 InitEntryPointArgs = virtual
```

**Step 3** set LawfulIntercept script object to ServerIncoming scripting point;

```
[//localhost/Radius]
 IncomingScript~ = LiScript
```



**Note**

The file 'libLiScript.so' comes up with Cisco Prime AR kit. You have to copy it into /cisco-ar/scripts/radius/rex/ path.

**Step 4** Save the configuration:

**save**

**Step 5** Reload the configuration:

**reload**





# CHAPTER 11

## Using Extension Points

---

This chapter describes how to use Cisco Prime Access Registrar (Cisco Prime AR) scripting to customize your RADIUS server. You can write scripts to affect the way Cisco Prime AR handles and responds to requests and to change the behavior of Cisco Prime AR after a script is run.

All scripts reference the three dictionaries listed below, which are data structures that contain key/value pairs.

- **Request dictionary**—contains all of the attributes from the access-request or other incoming packets, such as the username, password, and service hints.
- **Response dictionary**—contains all of the attributes in the access-accept or other response packets. As these are the attributes the server sends back to the NAS, you can use this dictionary to add or remove attributes.
- **Environment dictionary**—contains well-known keys whose values enable scripts to communicate with Cisco Prime AR or to communicate with other scripts.

This chapter contains the following sections:

- [Determining the Goal of the Script](#)
- [Writing the Script](#)
- [Adding the Script Definition](#)
- [About the Tcl/Tk 8.3 Engine](#)
- [Cisco Prime Access Registrar Scripts](#)



**Note**

Cisco is not liable for scripts developed by clients. See [Client Scripting, page 1-6](#) in “Overview”.

---

## Determining the Goal of the Script

The goal of the script and its scripting point are tied together. For example, when you want to create a script that performs some special processing of a username before it is processed by the Cisco Prime AR server, you would reference this script as an *incoming* script.

When on the other hand, you would like to affect the response, such as setting a specific timeout when there is not one, you would reference the script as an *outgoing* script.

In order to be able to create a script, you need to understand the way Cisco Prime AR processes client requests. Cisco Prime AR processes requests and responses in a hierarchical fashion; incoming requests are processed from the most general to the most specific levels, whereas, outgoing responses are processed from the most specific to the most general levels. Extension points are available at each level.

An incoming script can be referenced at each of the following extension points:

- RADIUS server
- Vendor (of the immediate client)
- Client (individual NAS)
- NAS-Vendor-Behind-the-Proxy
- Client-Behind-the-Proxy
- Remote Server (of type RADIUS)
- Service

An authentication or authorization script can be referenced at each of the following extension points:

- Group Authentication
- User Authentication
- Group Authorization
- User Authorization

The outgoing script can be referenced at each of the following extension points:

- Service
- Client-Behind-the-Proxy
- NAS-Vendor-Behind-the-Proxy
- Client (individual NAS)
- NAS Vendor
- RADIUS server

## Writing the Script

You can write scripts in either Tcl or as shared libraries using C or C++. In this section, the scripts are shown in Tcl.

### Writing the Script

To write a script:

- 
- Step 1** Create the Tcl source file using an editor.
- Step 2** Give it a name.
- Step 3** Define one or more procedures, using the following syntax:
- ```
proc name {request response environment}
{Body}
```
- Step 4** Create the body of the script.

- Step 5** Save the file and copy it to the `/opt/CSCOar/scripts/radius/tcl` directory, or to the location you chose when you installed Cisco Prime AR.
-

Choosing the Type of Script

When you create a script, you can use any one or all of the three dictionaries: Request, Response, or Environment. Here is what each dictionary does it for you,

- When you use the Request dictionary, you can modify the contents of a NAS request. Scripts that use the Request dictionary are usually employed as incoming scripts.
- When you use the Response dictionary, you can modify what the server sends back to the NAS. These scripts are consequently employed as outgoing scripts.
- When you use the Environment dictionary, you can do the following:
 - Affect the behavior of the server after the script is run. For example, you can use the Environment dictionary to decide which of the multiple services to use for authorization, authentication, and accounting.
 - Communicate among scripts, as the scripts all share these three dictionaries. For example, when a script changes a value in the Environment dictionary, the updated value can be used in a subsequent script.

The following sections show scripts examples of all the three dictionaries:

- [Request Dictionary Script](#)
- [Response Dictionary Script](#)
- [Environment Dictionary Script](#)

Request Dictionary Script

The Request Dictionary script is referenced from the server's IncomingScript scripting point. It checks to see whether the request contains a **NAS-Identifier** or a **NAS-IP-Address**. When it does not, it sets the **NAS-IP-Address** from the request's source IP address.

```
proc MapSourceIPAddress {request response environment}
{
    if { ! ( [ $request containsKey NAS-Identifier ] ||
            [ $request containsKey NAS-IP-Address ] ) } {
        $request put NAS-IP-Address [ $environment get Source-IP-Address ]
    }
}
```

Tcl scripts interpret **\$request** arguments as active commands that can interpret strings from the Request dictionary, which contains keys and values.

The **containsKey** method has the syntax: `<$dict> containsKey <attribute>`. In this example, `<$dict>` refers to the Request dictionary and the attributes **NAS-identifier** and **NAS-IP-Address**. The **containsKey** method returns **1** when the dictionary contains the attribute, and **0** when it does not. Using the **containsKey** method prevents you from overwriting an existing value.

The **put** method has the syntax: `<$dict> put <attribute value>[<index>]`. In this example, `<$request>` refers to the Request dictionary and the attribute is **NAS-IP-Address**. The **put** method sets the NAS's IP address attribute.

The **get** method has the syntax: `<$dict> get <attribute>`. In this example, `<$dict>` refers to the Environment dictionary and `<attribute>` is the **Source-IP-Address**. The **get** method returns the value of the attribute from the environment dictionary.

For a list of the methods you can use with scripts, see [Appendix A, “Cisco Prime Access Registrar Tcl, REX and Java Dictionaries.”](#) They include **get**, **put**, and others.

Response Dictionary Script

This script is referenced from either the user record for users whose sessions are always PPP, or from the script, **AuthorizeService**, which checks the request to determine which service is desired. The script merges the Profile named **default-PPP-users** into the Response dictionary.

```
proc AuthorizePPP {request response environment}
{
    $response addProfile default-PPP-users
```

The **addProfile** method has the syntax: `<$dict> addProfile <profile>[<mode>]`. In this example, `<$dict>` refers to the Response dictionary and the profile is **default-PPP-users**. The script copies all of the attributes of the Profile `<profile>` into the dictionary.

Environment Dictionary Script

This script is referenced from the NAS Incoming Script scripting point. It looks for a realm name on the username attribute to determine which AAA services should be used for the request. When it finds `@radius`, it selects a set of AAA services that will proxy the request to a remote RADIUS server. When it finds `@tacacs`, it selects the Authentication Service that will proxy the request to a TACACS server for authentication. For all of the remaining usernames, it uses the default Service (as specified in the configuration by the administrator).

Note the function, **regsub**, is a Tcl function.

```
proc ParseProxyHints {request response environment} {
    set userName [ $request get User-Name ]
    if { [ regsub "@radius" $userName "" newUserNames ] } {
        $request put User-Name $newUserNames
        $radius put Authentication-Service "radius-proxy"
        $radius put Authorization-Service "radius-proxy"
        $radius put Accounting-Service "radius-proxy"
    } else {
        if { [ regsub "@tacacs" $userName "" newUserNames ] } {
            $request put User-Name
            $radius put Authentication-Service "tacacs-client"
```

Adding the Script Definition

After you have written the script, you must add the script definition to the Cisco Prime AR's script **Configuration** directory so it can be referenced. Adding the script definition involves:

- Specifying the script definition; it must include the following:
 - **Name**—used in other places in the configuration to refer to the script. It must be unique among all other scripts.
 - **Language**—can be either Tcl or REX (shared libraries)
 - **Filename**—the name you used when you created the file

- **EntryPoint**—the function name.

The **Name** and the **EntryPoint** can be the same name, however they do not have to be.

- Choosing a scripting point; nine exist for incoming and outgoing scripts. These include:
 - the server
 - the vendor of the immediate client
 - the immediate client
 - the vendor of the specific NAS
 - the specific NAS
 - the service (rex or tcl)
 - the group (only AA scripts)
 - the user record (only AA scripts)
 - remote server (only type RADIUS)

The rule of thumb to use in determining where to add the script is the most general scripts should be on the outermost points, whereas the most specific scripts should be on the innermost points.

Note

The client and the NAS are the same entity, unless the immediate client is acting as a proxy for the actual NAS.

This section contains the following topics:

- [Adding the Example Script Definition](#)
- [Choosing the Scripting Point](#)
- [Testing the Script](#)

Adding the Example Script Definition

In the server configuration a **Scripts** directory exists. You must add the script you created to this directory. To add the **ParseProxyHints** script to the Cisco Prime AR server, enter the following command and supply the following information:

```
Name=ParseProxyHints
Description=ParseProxyHints
Language=tcl
Filename=ParseProxyHints
Entrypoint=ParseProxyHints
```

```
aregcmd add /Radius/Scripts/ParseProxyHints ParseProxyHints tcl ParseProxyHints
ParseProxyHints
```

Choosing the Scripting Point

As the example script, **ParseProxyHints**, applies to a specific NAS (NAS1), the entry point should be that NAS. To specify the script at this scripting point, enter:

```
aregcmd set /Radius/Clients/NAS1/IncomingScript ParseProxyHints
```

Testing the Script

To test the script, you can use the **radclient** command, which lets you create and send packets. For more information about the **radclient** command, see [Chapter 2, “Using the aregcmd Commands.”](#)

About the Tcl/Tk 8.3 Engine

Cisco Prime AR uses Tcl engine is version Tcl/Tk8.3. Since the Tcl/Tk8.3 engine supports a multi-threading application environment, it can achieve much better performance than Tcl/Tk7.6.

Tcl/Tk8.3 also performs *byte-compile*, so no runtime interpretation is required.

Cisco Prime Access Registrar Scripts

The Cisco Prime AR scripts are stored in `/localhost/Radius/Scripts`. Most of the scripts are written in the RADIUS Extension language (REX). Some scripts are provided in both REX and Tcl. The scripts written in Tcl all begin with the letter **t** followed by their functional name. The Tcl scripts are listed below:

- tACMEOutgoingScript
- tAuthorizePPP
- tAuthorizeService
- tAuthorizeTelnet
- tMapSourceIPAddress
- tParseAARealm
- tParseAASRealm
- tParseProxyHints
- tParseServiceAndAARealmHints
- tParseServiceAndAAASRealmHints
- tParseServiceAndAARRealmHints
- tParseServiceAndAASRealmHints
- tParstServiceAndProxyHints
- tParseServiceHints

This section contains the following topics:

- [ACMEOutgoingScript](#)
- [AltigaIncomingScript](#)
- [AltigaOutgoingScript](#)
- [ANAAAOutgoing](#)
- [AscendIncomingScript](#)
- [AscendOutgoingScript](#)
- [AuthorizePPP](#)
- [AuthorizeService](#)
- [AuthorizeSLIP](#)
- [AuthorizeTelnet](#)
- [CabletronIncoming](#)

- [CabletronOutgoing](#)
- [CiscoIncoming](#)
- [CiscoOutgoing](#)
- [CiscoWithODAPIncomingScript](#)
- [ExecCLIDRule](#)
- [ExecDNISRule](#)
- [ExecFilterRule](#)
- [ExecNASIPRule](#)
- [ExecRealmRule](#)
- [ExecTimeRule](#)
- [LDAPOutage](#)
- [MapSourceIPAddress](#)
- [ParseAAAR realm](#)
- [ParseAAAS realm](#)
- [ParseAAR realm](#)
- [ParseAAS realm](#)
- [ParseProxyHints](#)
- [ParseServiceAndAAAR realm Hints](#)
- [ParseServiceAndAAAS realm Hints](#)
- [ParseServiceAndAAR realm Hints](#)
- [ParseServiceAndAAS realm Hints](#)
- [ParseServiceAndProxyHints](#)
- [ParseServiceHints](#)
- [ParseTranslationGroupsByCLID](#)
- [ParseTranslationGroupsByDNIS](#)
- [ParseTranslationGroupsByRealm](#)
- [UseCLIDAsSessionKey](#)
- [USRIncomingScript](#)
- [USRIncomingScript-IgnoreAccountingSignature](#)
- [USROutgoingScript](#)

ACMEOutgoingScript

ACMEOutgoingScript is referenced from Vendor ACME for the outgoing script. If the Cisco Prime AR server accepts this Access-Request and the response does not yet contain a Session-Timeout, set it to 3600 seconds.

AltigaIncomingScript

AltigaIncomingScript maps Altiga-proprietary attributes to Cisco Prime AR's global attribute space.

AltigaOutgoingScript

AltigaOutgoingScript maps Altiga attributes from Cisco Prime AR's global attribute space to the appropriate Altiga-proprietary attributes.

ANAAAOutgoing

ANAAAOutgoing can be referenced from either the client or vendor outgoing scripting point to be used in HRPD/EV-DO networks where Cisco Prime AR is the Access Network (AN) AAA server.

ANAAAOutgoing checks to see if the response contains the Callback-Id attribute. If the response contains the Callback-Id attribute and the value is less than 253 characters, ANAAAOutgoing prefixes a zero (0) to the value. For example, it changes "112" into "0112." The ANAAAOutgoing script always returns REX_OK.

AscendIncomingScript

AscendIncomingScript maps Ascend-proprietary attributes to Cisco Prime AR's global attribute space.

AscendOutgoingScript

AscendOutgoingScript maps Ascend attributes from Cisco Prime AR's global attribute space to the appropriate Ascend-proprietary attributes.

AuthorizePPP

AuthorizePPP is referenced from either the use record for users who's sessions are always PPP or from the from the script AuthorizeService, which checks the request to determine which service is desired. This script merges in the Profile named "default-PPP-users" into the response dictionary.

AuthorizeService

AuthorizeService is referenced from user record for users who's sessions might be PPP, SLIP or Telnet depending on how they are connecting to the NAS. This script checks the request to determine which service is desired. If it is telnet, it calls the script AuthorizeTelnet. If it is PPP, it calls the script AuthorizePPP. If it is SLIP, it calls the script AuthorizeSLIP. If it is none of these, it rejects the request.

AuthorizeSLIP

AuthorizeSLIP is referenced from either the user record for users who's sessions are always SLIP or from the from the script AuthorizeService, which checks the request to determine which service is desired. This script merges in the Profile named "default-SLIP-users" into the response dictionary.

AuthorizeTelnet

AuthorizeTelnet is referenced from either the user record for users who's sessions are always telnet or from the from the script AuthorizeService, which checks the request to determine which service is desired. This script merges in the Profile named "default-Telnet-users" into the response dictionary.

CabletronIncoming

CabletronIncoming maps Cabletron-proprietary attributes to Cisco Prime AR's global attribute space.

CabletronOutgoing

Use CabletronOutgoing to map Cisco-proprietary attributes from Cisco Prime AR's global attribute space to the appropriate Cabletron-proprietary attributes.

CiscoIncoming

Use CiscoIncoming to map Cisco-proprietary attributes to Cisco Prime AR's global attribute space.

CiscoOutgoing

Use CiscoOutgoing to map Cisco-proprietary attributes from Cisco Prime AR's global attribute space to the appropriate Cabletron-proprietary attributes.

CiscoWithODAPIncomingScript

Use CiscoWithODAPIncomingScript to map Cisco-proprietary attributes to Cisco Prime AR's global attribute space and to map ODAP requests to the appropriate services and session managers.

CiscoWithODAPIncomingScript checks the incoming NAS-Identifier sent by the client. If the NAS-Identifier does not equal odap-dhcp, the request is not an ODAP request. If the request is not an ODAP request, the script does no more ODAP-specific processing, and calls CiscoIncomingScript to allow it to process the request.

If the request is an ODAP request, CiscoWithODAPIncomingScript removes the NAS-Identifier attribute because it is no longer required. The script then sets the Authentication-Service and the Authorization-Service to odap-users and sets the Accounting-Service to odap-accounting.

ExecCLIDRule

ExecCLIDRule is referenced from the policy engine to determine the authentication and authorization service and policy based on the CLID set in the policy engine.

ExecDNISRule

ExecDNISRule is referenced from the policy engine to determine the authentication and authorization service and policy based on the DNIS set in the policy engine.

ExecFilterRule

ExecFilterRule is referenced from the policy engine to determine whether a user packet should be rejected or not based on whether a special character like "*", "/", "\" or "?" shows up in the packet.

ExecNASIPRule

ExecNASIPRule is referenced from the policy engine to enable configuration of policies based on the incoming NAS-IP-Address. You can configure two attributes, *client-ip-address* and *subnetmask*, to match the incoming NAS-IP-Address and its subnet mask. If the attributes match, ExecNASIPRule sets the environment variables (if they are configured in that rule).

ExecRealmRule

ExecRealmRule is referenced from the policy engine to determine the authentication and authorization service and policy based on the realm set in the policy engine.

ExecTimeRule

ExecTimeRule either rejects or accepts Access Request packets based on the time range specified in a user's login profile. You can configure the TimeRange and AcceptedProfile attributes.

The format for the TimeRange is to set the allowable days followed by the allowable times, as in:

TimeRange = dateRange, timeRange

The dateRange can be in the form of a date, a range of allowable dates, a day, or a range of allowable days. The timeRange should be in the form of hh:mm-hh:mm.

Here are a few examples:

mon-fri,09:00-17:00

Allows access Monday through Friday from 9 AM until 5 PM.

mon,09:00-17:00;tue-sat,12:00-13:00

Allows access on Monday from 9 AM until 5 PM and from 12 noon until 1 PM on Tuesday through Saturday

mon,09:00-24:00;tue,00:00-06:00

Allows access on Monday from 9 AM until Tuesday at 6 AM

1-13,10-17:00; 15,00:00-24:00

Allows access from the first of the month until the thirteenth of the month from 10 AM until 5 PM and all day on the fifteenth of the month

LDAPOutage

LDAPOutage is referenced from LDAP Services as OutageScript. LDAPOutage logs when the LDAP binding is lost.

MapSourceIPAddress

MapSourceIPAddress is referenced from the Cisco Prime AR server's IncomingScript scripting point. MapSourceIPAddress checks to see if the request contains either a NAS-Identifier or a NAS-IP-Address. If not, this script sets the NAS-IP-Address from the request's source IP address.

The Tcl version of this script is tMapSourceIPAddress.

ParseAAALealm

ParseAAALealm is referenced from the NAS IncomingScript scripting point. It looks for a realm name on the username attribute as a hint of which AAA service should be used for this request. If @<realm> is found, the AAA service is selected which has the same name as the realm.

ParseAAASRealm

ParseAAASRealm is referenced from the NAS incoming script extension point. ParseAAASRealm looks for a realm name on the username attribute as a hint of which AAA service and which SessionManager should be used for this request. If @<realm> is found, the AAA service and SessionManager which have the same name as the realm are selected.

ParseAARealm

ParseAARealm is referenced from the NAS IncomingScript scripting point. It looks for a realm name on the username attribute as a hint of which authentication and authorization service should be used for this request. If @<realm> is found, it selects the AA service that has the same name as the realm and the DefaultAccountingService (as specified in the configuration by the administrator).

The Tcl version of this script is named tParseAARealm.

ParseAASRealm

ParseAASRealm is referenced from the NAS IncomingScript scripting point. It looks for a realm name on the username attribute as a hint of which AA service and which SessionManager should be used for this request. If @<realm> is found, the AA service and the SessionManager which have the same name as the realm are selected. The Accounting service will be the DefaultAccountingService (as specified in the configuration by the administrator).

The Tcl version of this script is named tParseAASRealm.

ParseProxyHints

ParseProxyHints is referenced from the NAS IncomingScript scripting point. It looks for a realm name on the username attribute as a hint of which AAA services should be used for this request. If @radius is found, a set of AAA services is selected which will proxy the request to a remote radius server. If @tacacs is found, the AuthenticationService is selected that will proxy the request to a tacacs server for authentication. For any services not selected, the default service (as specified in the configuration by the administrator) will be used.

The Tcl version of this script is named tParseProxyHints.

ParseServiceAndAAAR realmHints

ParseServiceAndAAAR realmHints is referenced from the NAS IncomingScript scripting point. It calls both ParseServiceHints and ParseAAAR realm.

The Tcl version of this script is named tParseServiceAndAAAR realmHints.

ParseServiceAndAAASRealmHints

ParseServiceAndAAASRealmHints is referenced from the NAS IncomingScript scripting point. It calls both ParseServiceHints and ParseAAASRealm.

The Tcl version of this script is named tParseServiceAndAAASRealmHints.

ParseServiceAndAAR realmHints

ParseServiceAndAAR realmHints is referenced from the NAS IncomingScript scripting point. It calls both ParseServiceHints and ParseAAR realm.

The Tcl version of this script is named tParseServiceAndAAR realmHints.

ParseServiceAndAASRealmHints

ParseServiceAndAASRealmHints is referenced from the NAS IncomingScript scripting point. It calls both ParseServiceHints and ParseAASRealm.

The Tcl version of this script is named tParseServiceAndAASRealmHints.

ParseServiceAndProxyHints

ParseServiceAndProxyHints is referenced from the NAS IncomingScript scripting point. It calls both ParseServiceHints and ParseProxyHints.

The Tcl version of this script is named tParseServiceAndProxyHints.

ParseServiceHints

ParseServiceHints is referenced from the NAS IncomingScript scripting point. Check to see if we are given a hint of the service type or the realm. If so, set the appropriate attributes in the request or radius dictionary to record the hint and rewrite the username to remove the hint.

The Tcl version of this script is named tParseServiceHints.

ParseTranslationGroupsByCLID

ParseTranslationGroupsByCLID is referenced from the policy engine to determine the incoming and outgoing translation groups based on CLID set in the policy engine so that the attributes can be added and/or filtered out by the configuration data set in MCD.

ParseTranslationGroupsByDNIS

ParseTranslationGroupsByDNIS is referenced from the policy engine to determine the incoming and outgoing translation groups based on realm set in the policy engine so that the attributes can be added/filtered out by the configuration data set in MCD.

ParseTranslationGroupsByRealm

ParseTranslationGroupsByRealm is referenced from the policy engine to determine the incoming and outgoing translation groups based on the realm set in the policy engine.

ParseTranslationGroupsByRealm allows the attributes to be added or filtered out by the configuration data set in MCD.

UseCLIDAsSessionKey

UseCLIDAsSessionKey is used to specify that the Calling-Station-Id attribute should be used as the session key to correlate requests for the same session. This is a typical case for 3G mobile user session correlation.

USRIncomingScript

USRIncomingScript maps USR-proprietary attributes to Cisco Prime AR's global attribute space.

USRIncomingScript-IgnoreAccountingSignature

USRIncomingScript-IgnoreAccountingSignature maps USR-proprietary attributes to Cisco Prime AR's global attribute space and sets a flag to ignore the signature on Accounting-Request packets. Earlier versions of the USR RADIUS client did not correctly sign Accounting-Request packets.

USROutgoingScript

USROutgoingScript maps USR attributes from Cisco Prime AR's global attribute space to the appropriate USR-proprietary attributes.



CHAPTER 12

Using Replication

This chapter provides information about how to use the replication feature in Cisco Prime Access Registrar (Cisco Prime AR).

This chapter contains the following sections:

- [Replication Overview](#)
- [How Replication Works](#)
- [Replication Configuration Settings](#)
- [Setting Up Replication](#)
- [Replication Example](#)
- [Full Resynchronization](#)
- [Replication Setup with More Than One Slave](#)
- [Frequently Asked Questions](#)
- [Replication Log Messages](#)



Note

When using replication, use the **aregcmd** command-line interface to make configuration changes to the Cisco Prime AR server. Replication is not supported when using the GUI.

Replication Overview

Cisco Prime AR replication feature can maintain identical configurations on multiple machines simultaneously. When replication is properly configured, changes an administrator makes on the primary or *master* machine are propagated by Cisco Prime AR to a secondary or *slave* machine.

Replication eliminates the need to have administrators with multiple Cisco Prime AR installations make the same configuration changes at each of their installations. Instead, only the master's configuration need be changed and the slave is automatically configured eliminating the need to make repetitive, error-prone configuration changes for each individual installation. In addition to enhancing server configuration management, using replication eliminates the need for a hot-standby machine.

Using a hot-standby machine is a common practice to provide more fault-tolerance where a fully-installed and configured system stands ready to takeover should the primary machine fail. However, a system setup for hot-standby is essentially an idle machine only used when the primary

system fails. Hot-standby or secondary servers are expensive resources. Employing Cisco Prime AR's replication feature, both servers can perform RADIUS request processing simultaneously, eliminating wasted resources.

The replication feature focuses on configuration maintenance only, not session information or installation-specific information such as Administrator, Interface, Replication or Advanced machine-specific configuration changes. These configuration items are not replicated because they are specific to each installation and are not likely to be identical between master and slave. While changes to Session Managers, Resource Manager, and Remote Servers are replicated to the slave and stored in the slave's configuration database, they are not hot-configured on the slave (see Hot Configuration Detailed below for more information)

Changes should be made only on the master server. Making changes on a slave server will not be replicated and might result in an unstable configuration on the slave. Any changes made using replication will not be reflected in existing **aregcmd** sessions. **aregcmd** only loads its configuration at start up; it is not dynamically updated. For example, if **aregcmd** is running on the slave, and on the master **aregcmd** is used to add a client, the new client, while correctly replicated and hot-configured, will not be visible in the slave's **aregcmd** until **aregcmd** is exited and restarted.

When there is a configuration change, the master server propagates the change set to all member servers over the network. All member servers have to update their configuration after receiving the change set notifications from master server. Propagating the change set to a member server involves multiple packet transfer from the master server to the member because the master server has to convey all the configuration changes to the member. The number of packets to be transferred depends on the size of the change set.

After receiving a change set notification, the member server will go offline before applying the change set received from master server. This state is indicated by the log message `Radius Server is offline` in **name_radius_1_log** file. When the change set is successfully applied, the member server goes up automatically. This is indicated by the log message `Radius Server is online` in **name_radius_1_log** file. When the member server goes offline to apply the change set, no incoming packets are processed.

Due to the number of packets to be transferred in the change set and the amount of time the member server will be offline updating its database points, Cisco recommends that you use multiple **save** commands rather than a large configuration change with one **save** command. You can also minimize the number of changes that occur in a replication interval by modifying either the `RepTransactionArchiveLimit` or the `RepTransactionSyncInterval`, or both of these properties. For example, instead of using the default value of 100 for the `RepTransactionArchiveLimit`, you might change it to 20.

Note

The IP address format is enhanced to support both IPv4 and IPv6.

How Replication Works

The following sections describe the flow of a simple replication as it occurs under normal conditions:

- [Replication Data Flow](#)
- [Security](#)
- [Replication Archive](#)
- [Ensuring Data Integrity](#)
- [Full Resynchronization](#)

- [Understanding Hot-Configuration](#)
- [Replication's Impact on Request Processing](#)

Replication Data Flow

The following sections describe data flow on the master server and the slave server:

- [Master Server](#)
- [Slave Server](#)

Master Server

The master server or primary server is the fully configured machine that is used to archive all the transactions that taken place in Cisco Prime AR.

Performing the Data Flow for the Master Server

To perform data flow for the master server:

-
- Step 1** The administrator makes a change to the master server's configuration using the **aregcmd** command line interface (CLI) and issues a **save** command.
 - Step 2** After the changes are successfully validated, the changes are stored in the Cisco Prime AR database.
 - Step 3** **aregcmd** then notifies the Cisco Prime AR server executing on the master of the configuration change.
 - Step 4** The Cisco Prime AR server then updates its version of the configuration stored in memory. (This is called *hot-config* because it happens while the server is running and processing requests.)
 - Step 5** The Cisco Prime AR server first copies the changes pertaining to the **aregcmd save**, also known as a transaction to its replication archive, then transmits the transaction to the slave server for processing.
 - Step 6** In **aregcmd**, the prompt returns indicating that the **save** has completed successfully, the transaction has been archived, and the transaction has been transmitted to the slaves.
-

Slave Server

The slave server or secondary server is a fully-installed and configured system stands ready to takeover when the primary machine fails.

Performing Data Flow for the Slave Server

To perform data flow for the slave server:

-
- Step 1** When the slave server receives the transaction, its contents are verified.
 - Step 2** After verification, the changes are applied to the slave server's database.
 - Step 3** The changes are then applied (hot-configured) in the slave server's in-memory configuration.
 - Step 4** The transaction is written to the slave server's replication archive.
-

Security

Replication has two primary security concerns:

1. Security of the transactions transmitted to the slave server
2. Storage of transactions in the replication archive

Both of these concerns use shared secret (MD5) encryption via the shared secret specified in the replication configuration on both master and slave servers. Replication data transmitted between master and slave is encrypted at the source and decrypted at the destination the same way as standard RADIUS packets between Cisco Prime AR's clients and the Cisco Prime AR server. Transactions written to the replication archive are also encrypted in the same manner and decrypted when read from the replication archive.

Replication Archive

The replication archive serves two primary purposes:

- To provide persistent, or saved, information regarding the last successful transaction
- To persist transactions in case the slave server requires re synchronization (see Ensuring Data Integrity below for more information on re synchronization).

The replication archive is simply a directory located in `../CSCOAr/data/archive`. Each transaction replicated by the master is written to this directory as a single file. The name of each transaction file is of the form `txn#####` where `#####` is the unique transaction number assigned by the master server. The replication archive size, that is the number of transaction files it might contain, is configured in the Replication configuration setting of `TransactionArchiveLimit`. When the `TransactionArchive` limit is exceeded, the oldest transaction file is deleted.

Ensuring Data Integrity

Cisco Prime AR's configuration replication feature ensures data integrity through transaction data verification, transaction ordering, automatic resynchronization and manual full-resynchronization. With the single exception of a manual full-resynchronization, each of the following techniques help to automatically ensure that master and slave servers contain identical configurations. A detailed description of each technique follows. This section contains the following topics:

- [Transaction Data Verification](#)
- [Transaction Order](#)
- [Automatic Resynchronization](#)

Transaction Data Verification

When the master prepares a transaction for replication to a slave, the master calculates a 2's complement Cyclic Redundancy Check (CRC) for each element (individual configuration change) in the transaction and for the entire transaction and includes these CRC values in the transmitted transaction. When the slave receives the transaction, the slave calculates a CRC for each transaction element and for the entire transaction and compares its own calculated values with those sent with the message. If a discrepancy occurs from these comparisons, the transaction element or the entire transaction is discarded and a re-transmission of that particular transaction element or the entire transaction is requested by the slave from the master. This process is called automatic resynchronization. (described in more detail below)

Transaction Order

When the master prepares a transaction for replication, it assigns the transaction a unique transaction number. This number is used to ensure the transactions are processed by the slave in exactly the same order as they were processed on the master. Transactions are order dependent. Since the functionality of Cisco Prime AR's configuration replication feature is to maintain identical configurations between master and slave, if transaction order were not retained, master and slave would not contain identical configurations. Consider where two transactions modify the same thing (a defined client's IP address for example). If the first transaction was a mistake and the second was the desired result, the client configuration on the master would contain the second setting; however, if the transactions were processed in the reverse order on the slave, the client configuration on the slave would contain the mistaken IP Address. This example illustrates the critical need for transaction ordering to ensure data integrity.

Automatic Resynchronization

Automatic Resynchronization is the most significant feature with respect to data integrity. This feature ensures the configurations on both the master and slave are identical. If they are not, this feature automatically corrects the problem.

When the master and slave start-up, they determine the transaction number of the last replication transaction from their respective replication archives. The master immediately begins periodic transmission of a TransactionSync message to the slave. This message informs the slave of the transaction number of the transaction that the master last replicated.

If the transaction number in the TransactionSync message does not match the transaction number of the last received transaction in the slave's archive, then the slave will request resynchronization from the master. The resynchronization request sent by the slave will include the slave's last received transaction number.

The master will respond by retransmitting each transaction since the last transaction number indicated by the slave in the resynchronization request. The master obtains these transactions from its replication archive.

Should the slave's last received transaction number be less than the lowest transaction number in the master's replication archive, then automatic resynchronization cannot occur as the master's replication archive does not contain enough history to synchronize the slave. In this case, the slave must be resynchronized with a full-resynchronization.

Full Resynchronization

Full Resynchronization means that the slave has missed more transactions than are stored in the master's replication archive and cannot be resynchronized automatically. There is no automatic full-resynchronization mechanism in Cisco Prime AR's configuration replication feature. To perform a full resynchronization, see the *Cisco Prime Access Registrar User's Guide, 6.0*.

Understanding Hot-Configuration

Hot-Configuration is the process of reflecting configuration changes made to Cisco Prime AR's internal configuration database in the in-memory configuration of the executing Cisco Prime AR server.

Hot-Configuration is accomplished without interruption of RADIUS request processing. For example, if an administrator uses **aregcmd** to configure a new client and issues a **save** command, when the prompt returns, the newly configured client can send requests to Cisco Prime AR.

Hot-Configuration minimizes the down-time associated with having to restart an Cisco Prime AR server to put configuration changes into effect. With the Hot-Configuration feature, a restart is only necessary when a Session Manager, Resource Manager or Remote Server configuration is modified. These configuration elements might not be hot-configured because they maintain state (an active session, for example) and cannot be modified without losing the state information they maintain. Changes to these configuration elements require a restart of Cisco Prime AR to put them into effect.

Hot-Configuration is not associated with the replication feature. Hot-Configuration's only connection to the replication feature is that when a change is replicated to the slave, the slave is hot-configured to reflect the replicated change as if an administrator had used **aregcmd** to make the changes directly on the slave server.

Replication's Impact on Request Processing

The replication feature was designed to perform replication of transactions with minimal impact on RADIUS request processing. When a transaction is received by a slave, RADIUS requests are queued while the transaction is applied to the slave. After the transaction is complete, RADIUS request processing resumes.

The impact on RADIUS request processing is a direct result of the size of a transaction. The smaller the transaction the lesser the impact, and the larger the transaction, the greater the impact. In other words, when making changes to the master, frequent saves are better than making lots of changes and then saving. Each change is one transaction element and all changes involved in a **save** comprise a single transaction with one element per change. Since the replication feature only impacts RADIUS request processing when changes are made, the impact under normal operation (when changes are not being made) is virtually unmeasurable.

Replication Configuration Settings

This section describes each replication configuration setting. In **aregcmd**, replication settings are found in **//localhost/Radius/Replication**. This section contains the following topics:

- [RepType](#)
- [RepTransactionSyncInterval](#)
- [RepTransactionArchiveLimit](#)
- [RepIPAddress](#)
- [RepPort](#)
- [RepSecret](#)
- [RepIsMaster](#)
- [RepMasterIPAddress](#)
- [RepMasterPort](#)

- [Rep Members Subdirectory](#)
- [Rep Members/Slave1](#)
- [Name](#)
- [IPAddress](#)
- [Port](#)

RepType

RepType indicates the type of replication. The choices available are SMDBR and NONE.

When RepType is set to NONE, replication is disabled. To enable replication, set RepType to SMDBR for Single Master DataBase Replication. RepType must be set to SMDBR on both the master and slave servers.

RepTransactionSyncInterval

Master

On the master server, RepTransactionSyncInterval is the duration between periodic transmission of the TransactionSync message expressed in milliseconds. The default is 60000 or 1 minute.

The purpose of RepTransactionSyncInterval is to indicate how frequently to check for an out-of-sync condition between the master and slave servers. When the slave received the TransactionSync message, it uses its contents to determine if it needs to resynchronize with the master.

The larger the setting for RepTransactionSyncInterval, the longer the period of time between out-of-sync detection. However, if RepTransactionSyncInterval is set too small, the slave can frequently request resynchronization when it is not really out of sync. If the duration is too small, the slave cannot completely receive a transaction before it receives the TransactionSync message. In this case, the servers will remain synchronized, but there will be unnecessary excess traffic that could affect performance.



Note

Cisco recommends that you use smaller values for the RepTransactionSyncInterval to limit the time a slave server is offline applying change sets during automatic resynchronization.

Slave

On the slave, RepTransactionSyncInterval is used to determine if the slave has lost contact with the master and to alert administrators of a possible loss of connectivity between the master and slave. If the elapsed time since the last received TransactionSync message exceeds the setting of RepTransactionSyncInterval, the slave writes a log message indicating that it might have lost contact with the master. This log message is repeated each TransactionSyncInterval until a TransactionSync message is received.

RepTransactionArchiveLimit

On both master and slave, the RepTransactionArchiveLimit setting determines how many transactions can be stored in the archive. The default setting is 100. When the limit is exceeded, the oldest transaction file is deleted. If a slave requires resynchronization and the last transaction it received is no longer in the archive, a full resynchronization will be necessary to bring the slave back in sync with the master.

**Note**

The value set for RepTransactionArchiveLimit should be the same on the master and the slave.

An appropriate value for RepTransactionArchiveLimit depends upon how much hard disk space an administrator can provide for resynchronization. If this value is large, say 10,000, then the last 10,000 transactions will be stored in the archive. This is like saying the last 10,000 saves from **aregcmd** will be stored in the archive. Large values are best. The size of each transaction depends upon how many configuration changes were included in the transaction, so hard disk space usage is difficult to estimate.

**Note**

Cisco recommends that you use smaller values for the RepTransactionArchiveLimit to limit the time a slave server is offline applying change sets during automatic resynchronization.

If the slave should go down or otherwise be taken off line, the value of RepTransactionArchiveLimit and the frequency of **aregcmd** saves will determine how long the slave can be offline before a full-resynchronization will be required.

There are two reasons why a slave server should have an archive:

1. The slave must save the last received transaction for resynchronization purposes (at a minimum).
2. Should the master go down, the slave can then be configured as the master and provide resynchronization services to other slaves.

RepIPAddress

The RepIPAddress value is set to the IP Address of the machine containing the Cisco Prime AR installation.

**Note**

The IP address format is enhanced to support both IPv4 and IPv6.

RepPort

The RepPort is the port used to receive of replication messages. In most cases, the default value (1645) is sufficient. If another port is to be used, the interfaces must exist in the machine.

RepSecret

RepSecret is the replication secret shared between the master and slave. The value of this setting must be identical on both the master and the slave.

RepIsMaster

The RepIsMaster setting indicates whether the machine is a master or a slave. On the master, set RepIsMaster to TRUE. On the slave set it to FALSE. Only the master can have this value set to TRUE and there can be only one master.

RepMasterIPAddress

RepMasterIPAddress specifies the IP Address of the master. On the master, set RepMasterIPAddress to the same value used in RepIPAddress above. On the slave, RepMasterIPAddress must be set to the IP Address of the master.

**Note**

The IP address format is enhanced to support both IPv4 and IPv6.

RepMasterPort

RepMasterPort is the port to use to send replication messages to the master. In most cases, the default value (1645) is sufficient; however, if another is to be used, the interfaces must exist in the machine.

Rep Members Subdirectory

The Rep **Members**\ subdirectory contains the list of slaves to which the master will replicate transactions.

Rep Members/Slave1

Each slave is added much like a client is added. Each slave must have a configuration in the Rep Members directory to be considered part of the *replication network* by the master. The master will not transmit any messages or replications to servers not in this list, and any communication received by a server not in this list will be ignored.

**Note**

Although it is possible to configure multiple slaves with the same master, we have only considered a single-master/single-slave configuration. This is the recommended configuration.

Name

This is the name of the slave. The name must be unique.

IPAddress

This is the IP Address of the slave.

**Note**

The IP address format is enhanced to support both IPv4 and IPv6.

Port

This is the port upon which the master will send replication messages to the slave.

Setting Up Replication

This section provides step-by-step instructions about how to configure replication on both the master and member servers. The following section, “[Replication Example](#)” section on page 12-13, shows an example of replication configuration.

If possible, open an **xterm** window on both the master and member. In each of these windows, change directory to **\$INSTALL/logs** and run **xtail** to watch the logs. This allows you to watch replication log messages as they occur. If you are using a system which had a previous installation of Cisco Prime AR, delete all files located in the **\$INSTALL/data/archive** directory if it is present on either the master or member systems. This section contains the following topics:

- [Configuring The Master](#)
- [Configuring The Member](#)
- [Verifying the Configuration](#)

Configuring The Master

On the master server, **RepTransactionSyncInterval** is the duration between periodic transmission of the **TransactionSync** message expressed in milliseconds. The default is 60000 or 1 minute.

Configuring the Master Server for Replication

To configure the master server for replication:

-
- Step 1** On the machine which is to be the master, using **aregcmd**, navigate to **//localhost/Radius/Replication**
- Step 2** Set the **RepType** to **SMDBR**:
- ```
set RepType SMDBR
```
- Step 3** Set the **RepIPAddress** to the IP address of the master:
- ```
set RepIPAddress 192.168.1.1
```
- Step 4** Set the **RepSecret** to **MySecret**:
- ```
set RepSecret MySecret
```
- Step 5** Set **RepIsMaster** to **TRUE**:
- ```
set RepIsMaster TRUE
```

Step 6 Set RepMasterIPAddress to the same value used in step 3:

```
set RepMasterIPAddress 192.168.1.1
```

Step 7 Change directory to **/Radius/Advanced** and set the **MaximumNumberOfRadiusPackets** property to 8192:

```
cd /Radius/Advanced
```

```
set MaximumNumberOfRadiusPackets 8192
```

Step 8 Change directory to **Rep Members**:

```
cd "rep members"
```



Note You must enclose Rep Members in quotes due to the space in the name.

Step 9 Add **member1**:

```
add member1
```

Step 10 Change directory to **member1**:

```
cd member1
```

Step 11 Set the IPAddress to the IP Address of the machine to be the member:

```
set IPAddress 192.168.1.2
```



Note The RepPort and RepMasterPort properties on the Master must correspond to one of the ports configured in **/Radius/Advanced/Ports**, if one is configured. Otherwise, the default values for the RepPort and RepMasterPort properties are sufficient.

Step 12 Save the configuration:

```
save
```

Step 13 Reload the configuration:

```
reload
```

Configuring The Member

On the slave, RepTransactionSyncInterval is used to determine if the slave has lost contact with the master and to alert administrators of a possible loss of connectivity between the master and slave.

Configuring the Member Server for Replication

To configure the member server for replication:

Step 1 On the machine which is to be the member, using **aregcmd**, navigate to **//localhost/Radius/Replication**.

Step 2 Set the RepType to SMDBR.

```
set RepType SMDBR
```

Step 3 Set the RepIPAddress to the IP address of the member.

```
set RepIPAddress 192.168.1.2
```

Step 4 Set the RepSecret to MySecret.

```
set RepSecret MySecret
```

Step 5 Set RepMasterIPAddress to IP Address of the master (the same value used in Step 3 on page 8-1).

```
set RepMasterIPAddress 192.168.1.1
```

Step 6 Change directory to **/Radius/Advanced** and set the **MaximumNumberOfRadiusPackets** property to 8192.

```
cd /Radius/Advanced
```

```
set MaximumNumberOfRadiusPackets 8192
```

Step 7 If the Master has been configured to use a port other than the well-known (and default) RADIUS ports, configure each Member to use the same port.



Note The RepPort and RepMasterPort properties on the Master must correspond to one of the ports configured in **/Radius/Advanced/Ports**, if one is configured. Otherwise, the default values for the RepPort and RepMasterPort properties are sufficient.

Step 8 Save the configuration:

```
save
```

Step 9 Reload the configuration:

```
reload
```

Verifying the Configuration

After both servers have successfully started, use **aregcmd** to make a small change to be replicated to the member server which you can easily verify. We recommend setting the description in **//localhost/Radius** to something like *Test1*. After you issue an **aregcmd save** and the prompt returns, run **aregcmd** on the member server and change directory to **//localhost/Radius**. Ensure that the description is set to Test1. If this was successful, then replication is properly configured and functional.

Replication Example

This section provides an example of replication and shows the actions that occur.

Adding a User

The **Users** object contains all of the information necessary to authenticate a user or authorize a user. Users in local UserLists can have multiple profiles. On the master server, use **aregcmd** to add a new user to the default user list.

Adding a New User

To add a new user:

-
- Step 1** Change directory to `//localhost/Radius/UserLists/Default`.
- Step 2** Enter the following:
- ```
add testuser
```
- Step 3** Change directory to `testuser`.
- ```
cd testuser
```
- Step 4** Set the password for `testuser`.
- ```
set password testuser
```
- Step 5** Confirm the password by entering `testuser` again.
- Step 6** Enter `save` to save the configuration.
- 

## Master Server's Log

The log on the master shows the following:

```
*** ./name_radius_1_log ***
10/23/2008 23:17:07 name/radius/1 Info Server 0 Initiating Replication of Transaction
1 with 2 Elements.
10/23/2008 23:17:07 name/radius/1 Info Server 0 Replication Transaction #1 With 2
Elements Initiated
```

## Member Server's Log

The log on the member shows the following:

```
*** ./name_radius_1_log ***
10/23/2008 23:15:18 name/radius/1 Info Server 0 Radius Server is On-Line
10/23/2008 23:17:12 name/radius/1 Info Server 0 Committing Replication of Transaction
1 with 2 Elements.
10/23/2008 23:17:16 name/radius/1 Info Server 0 Replication Transaction #1 With 2
Elements Committed.
```

## Verifying Replication

You can use one of two methods to verify that the new user `testuser` was properly replicated to the member:

- Run **aregcmd** on the member and look at the default `userlist` to see if it is there.
- Run **radclient** on the member and enter **simple testuser testuser** to create a simple access request packet (p001).

Enter **p001 send** to send it. When it returns with p002, enter **p002** to see if it is an Access Accept packet or an Access Reject packet. If it is an Access Accept, the user was properly replicated to the member. Using **radclient** is the recommended method to validate that a user was properly replicated.

On the Master, use **aregcmd** to delete the user from the default user list and save the user list.

## Master Server's Log

The log on the master shows the following:

```
*** ./name_radius_1_log ***
10/23/2008 23:20:48 name/radius/1 Info Server 0 Initiating Replication of Transaction
2 with 1 Elements.
10/23/2008 23:20:48 name/radius/1 Info Server 0 Replication Transaction #2 With 1
Elements Initiated
```

## Member Server's Log

The log on the member shows the following:

```
*** ./name_radius_1_log ***
10/23/2008 23:20:53 name/radius/1 Info Server 0 Committing Replication of Transaction
2 with 1 Elements.
10/23/2008 23:20:57 name/radius/1 Info Server 0 Replication Transaction #2 With 1
Elements Committed.
```

Repeat the validation procedure above to ensure the user `testuser` is no longer present on the member.

## Using aregcmd -pf Option

Cisco Prime AR's replication feature works well using **aregcmd** input files. An **aregcmd** input file contains a list of **aregcmd** commands. For example, if the initial configuration of Cisco Prime AR were constructed in an input file, the master and member could be configured for replication first, then the input file applied to the master will be automatically replicated to the member.

### Using aregcmd -pf Option

To illustrate replication using an **aregcmd** input file:

---

**Step 1** Create a text file called **add5users** with the following commands:

```
add /Radius/UserLists/Default/testuser1
cd /Radius/UserLists/Default/testuser1
```

```
set password testuser1
add /Radius/UserLists/Default/testuser2
cd /Radius/UserLists/Default/testuser2
set password testuser2
add /Radius/UserLists/Default/testuser3
cd /Radius/UserLists/Default/testuser3
set password testuser3
add /Radius/UserLists/Default/testuser4
cd /Radius/UserLists/Default/testuser4
set password testuser4
add /Radius/UserLists/Default/testuser5
cd /Radius/UserLists/Default/testuser5
set password testuser5
save
```

**Step 2** On the master server, run the following command:

```
aregcmd -pf add5users
```

---

## Master Server's Log

The log on the master shows the following:

```
*** ./name_radius_1_log ***
10/23/2008 23:27:08 name/radius/1 Info Server 0 Initiating Replication of Transaction
3 with 10 Elements.
10/23/2008 23:27:08 name/radius/1 Info Server 0 Replication Transaction #3 With 10
Elements Initiated
```

## Member Server's Log

The log on the member shows the following:

```
*** ./name_radius_1_log ***
10/23/2008 23:27:12 name/radius/1 Info Server 0 Committing Replication of Transaction
3 with 10 Elements.
10/23/2008 23:27:17 name/radius/1 Info Server 0 Replication Transaction #3 With 10
Elements Committed.
```

When the prompt returns, go to the member and use **aregcmd** to view the **/radius/defaults/userlist**. There should be five users there named *testuser1* through *testuser5*.

## An Automatic Resynchronization Example

This example will illustrate resynchronization of the member. This will be accomplished by stopping the member, making changes on the master, then restarting the member forcing a resynchronization.

### Performing Resynchronization of the Member

To perform resynchronization of the member:

---

**Step 1** At the member, stop the Cisco Prime AR server:

```
/etc/init.d/arservagt stop
```

At the master, run **aregcmd** and change directory to **/radius/userlist/default**.

```
cd /radius/userlist/default
```

**Step 2** Enter the following:

```
add foouser
```

**Step 3** Change directory to **foouser**.

```
cd foouser
```

**Step 4** Set the password for **foouser**.

```
set password foouser
```

**Step 5** Confirm the password by entering **foouser** again.

**Step 6** Save the configuration:

```
save
```

---

## Master Server's Log

The log on the master shows the following:

```
*** ./name_radius_1_log ***
10/23/2008 23:31:02 name/radius/1 Info Server 0 Initiating Replication of Transaction
5 with 2 Elements.
10/23/2008 23:31:02 name/radius/1 Info Server 0 Replication Transaction #5 With2
Elements Initiated
```

On the member, run **/etc/init.d/arservagt start**. Notice the following log messages in the Master's log:

```
*** ./name_radius_1_log ***
10/23/2008 23:33:19 name/radius/1 Info Server 0 Resynchronizing member1.
```

## Member Server's Log

The log on the member shows the following:

```
*** ./name_radius_1_log ***
11/07/2008 23:33:14 name/radius/1 Info Server 0 Radius Server is Off-Line
11/07/2008 23:33:14 name/radius/1 Info Server 0 Starting Replication Manager
11/07/2008 23:33:24 name/radius/1 Info Server 0 Master Selected As Partner (DEFAULT)
11/07/2008 23:33:24 name/radius/1 Info Server 0 Radius Server is Off-Line
11/07/2008 23:33:24 name/radius/1 Warning Server 0 Requesting resynchronization from
Master: Last Txn#3
11/07/2008 23:33:24 name/radius/1 Info Server 0 Resynchronization from Master in
progress.
11/07/2008 23:33:24 name/radius/1 Info Server 0 Committing Replication of Transaction
4 with 2 Elements.
11/07/2008 23:33:28 name/radius/1 Info Server 0 Replication Transaction #4 With 2
Elements Committed.
11/07/2008 23:33:28 name/radius/1 Info Server 0 Radius Server is On-Line
```

As the log above shows, when the member started up, it validated its last received transaction number (#3) with the master's last replicated transaction number (#4). They did not match because a replication was initiated by the master which was not received by the member (because the member was stopped). When the member detected this discrepancy, the member made a resynchronization request to the master. The master responded by transmitting the missed transaction (#4) to the member. After it received and processed the retransmitted transaction, the member determined that it was then synchronized with the master and placed itself in an online status.

## Full Resynchronization

Full Resynchronization means that the member has missed more transactions than are stored in the master's replication archive and can not be resynchronized automatically. There is no automatic full-resynchronization mechanism in Cisco Prime AR's configuration replication feature. If a full resynchronization is required, you must export the master server's database and update the member configuration.



### Note

Before beginning, ensure there are no **aregcmd** sessions logged into the master server.

### Performing a Manual Full-resynchronization

To perform a manual full-resynchronization:

- 
- Step 1** On the master server, stop the Cisco Prime AR server agent using the following command:
- ```
/etc/init.d/arserver stop
```
- Step 2** On the master server, change directory to **\$INSTALL/data/db**.
- Step 3** Create a tarfile made up of the three database files, **mcddb.d01**, **mcddb.d02**, and **mcddb.d03**.
- ```
tar cvf /tmp/db.tar mcddb.d0*
```
- Step 4** Create a tarfile of the archive.
- ```
tar cvf /tmp/archive.tar $INSTALL/data/archive
```
- Step 5** On the master server, start the Cisco Prime AR server agent using the following command:

/etc/init.d/arserver start

Step 6 On each member server requiring resynchronization, perform the following:

- a. On the member server, stop the Cisco Prime AR server agent using the following command:

/etc/init.d/arserver stop

- b. Copy the tarfiles (**db.tar** and **archive.tar**) to **/tmp**.
 c. Change directory to **\$INSTALL/data/db**, then untar the compressed database files.

cd \$INSTALL/data/db

tar xvf /tmp/db.tar

- d. Rebuild the key files using the following command:

\$INSTALL/bin/keybuild mcddb



Note This step might take several minutes.

- e. Untar the archive.

cd \$INSTALL/data/archive

tar xvf /tmp/archive.tar

- f. As a safety check, run the following UNIX command to verify the integrity of the database.

\$INSTALL/bin/dbcheck mcddb



Note You must be user **root** to run **dbcheck**.

No errors should be detected.

- g. Start the Cisco Prime AR server agent using the following command:

/etc/init.d/arserver start



Note After you start the member server with the master server's database, you will probably see messages such as the following:

```
11/07/2008 23:21:23 name/radius/1 Error Server 0 TXN_SYNC: Failed to get master's
socket handle.
```

```
11/07/2008 23:21:49 name/radius/1 Warning Server 0 TXN_SYNC Received by Master from
unknown member 10.1.9.74. Validation Failed
```

These messages will likely continue until you complete steps **h** and **i**.

- h. Change directory to **//radius/replication** and change the following attributes:

- Change the RepIPAddress to that of the member.
- Change RepIsMaster to FALSE.

- Remove any entries under Rep Members.
- i. Save and reload the configuration.

save

```
Validating //localhost...  
Saving //localhost...
```

reload

The member will start up and show online status in the log after it has verified it is synchronized with the master.

Replication Setup with More Than One Slave

When replication is setup with more than one slave, Cisco Prime AR's replication feature ensures that all the servers maintain identical configuration. This is done by forming a communication mesh. This mesh is formed by every server choosing two partners for itself from the replication setup. The servers tend to receive/send configuration updates from/to its partners. This ensures that all the servers maintain identical configuration inspite of minimal communication failures.

When bringing up a replication setup, Cisco Prime AR server comes up first and then initiates a partner sync request to all its replication members as visible from the configuration. So, a slave server will initiate partner sync to its master only. This is because master server is the only server visible to the slave server from the configuration. The master server will then broadcast the partner syncs that it has received, to all its replication members (slaves). Based on the sync messages sent by the master to this server, the evaluation of workload happens. The partner selection is based on the workload evaluation. Choosing the partners based on workload, ensures that the workload is equally distributed across the partner network.

The partners are selected based on the count of partner syncs received from the master:

- If partner syncs that have been received is one, choose the master as a partner.
- If partner syncs that have been received is two, choose the master and the other replication server as partners.
- If partner syncs that have been received is greater than two, perform a workload evaluation on the partners. Identify two servers that do not have two partners and choose them as partners.

Frequently Asked Questions

Question: When I do a **save** in **aregcmd** and the validation fails, is anything replicated?

Answer: No; replication does not occur until **aregcmd** successfully saves the changes.

Question: Can I specify multiple masters with the same members?

Answer: No; the replication feature was designed to be used with a single-master. Also, it is not possible to specify more than one master in a member's configuration.

Question: Do I have to configure the master as a client on the member servers?

Answer: No. In-fact, it would be erroneous to do so. With the exception of Administrators, Interfaces, Replication, and Advanced machine-specific settings, the configuration between master and member must be identical. The replication feature's purpose is to maintain that relationship. Altering configuration settings on the member which are managed by the master will likely result in an unstable and possibly non-operational server.

Question: What configuration elements are replicated and what are not?

Answer: With the exception of Administrators, Interfaces, Replication, and Advanced machine-specific settings, all other settings are replicated.

Question: What configuration elements are hot-configured and what are not?

Answer: Session Managers, Resource Managers and Remote servers are not hot-configured because they maintain state, such as an active session, and cannot be manipulated dynamically.

Question: What is an appropriate TransactionSyncInterval setting?

Answer: This depends upon how long you want to allow an out-of-sync condition to persist. The shorter the interval, the more often an out-of-sync condition is checked. However, this results in added network traffic, additional processing by Cisco Prime AR and, if the interval is too small, frequent unnecessary resynchronization requests. The default value of 60,000 milliseconds (1 minute) is usually sufficient; however, values of as little as 10,000 milliseconds (10 seconds) have been tested and have worked well.

Question: What is an appropriate TransactionArchiveLimit setting?

Answer: This depends upon two things:

1. How much hard disk space you are willing to devote to transaction archive storage
2. How often your configuration is changed (a save is issued through Aregcmd).

If you have limited hard disk space, then perhaps smaller values (less than 1000) are appropriate; however if you have sufficient hard disk space, values of 10,000 or greater are better. The primary reason for this preference is to limit the possibility of a full-resynchronization being required. A full-resynchronization is required when the member has missed so many transactions that the master no longer contains all the transaction necessary to resynchronize the member. The greater the limit, the longer the member can be down without requiring a full-resynchronization.

Question: Can I specify a member in the member configuration?

Answer: Yes, and this is recommended. In the member's replication configuration Rep Members list, specify another server, perhaps one which can be used in-case of critical failure of the master. If the master suffers a catastrophic failure (a hard disk crash, for example) the member can be reconfigured to be the master simply by setting the RepIsMaster to TRUE and changing the MasterIPAddress to its own IP Address and the member specified in its Rep Members list will perform as the master. Because the member has an archive of transactions, the new member can be automatically resynchronized. If the archive limit on the new master has been exceeded (the transaction file txn0000000001 is no longer present in the new master's archive directory), then the new member will require a full-resynchronization. Setting the member up in this manner prevents down-time if the master fails and allows configuration changes to be made on the new master.

Question: How can I prevent a full-resynchronization from ever being necessary?

Answer: You can't, but you can limit the possibility by setting the TransactionArchiveLimit to a large value (greater than 10000). Another technique is to periodically check the archive when the master and member are synchronized. If the number of transaction files is approaching 10,000, then you can stop the master and member servers, delete all files in the replication archive, and restart the master and member. The only side effect is that if the master or member suffers a catastrophic failure, a full resynchronization will be required.

Question: Can I use the member to process RADIUS requests along with the master?

Answer: Yes, and this was one of the goals of the replication feature. Keep in mind that session information is not replicated between master and member. To use session management in this environment, use Cisco Prime AR's central session manager.

Replication Log Messages

This section contains typical replication log messages and explains what each means.

This section include the following topics:

- [Information Log Messages](#)
- [Warning Log Messages](#)
- [Error Log Messages](#)
- [Log Messages You Should Never See](#)

Information Log Messages

Info Message Starting Replication Manager

Displayed at start-up and indicates the Replication Manager is configured and enabled. (RepType=SMDBR)

Info Message Replication Disabled

Displayed at start-up and indicates that Replication is not enabled. (RepType=NONE)

Info Message Radius Server is On-Line

Displayed by the member at start-up to indicate the member is synchronized with the master and processing RADIUS requests. It is also displayed after a successfully completed resynchronization. This message is never displayed on the master.

Info Message Radius Server is Off-Line

Displayed by the member at start-up to indicate the radius server is not processing RADIUS requests until it can ensure synchronization with the master. When this is displayed after startup, it indicates the member is no longer synchronized with the master and is directly associated with a resynchronization request to the master. This message is never displayed on the master.

Info Message Resynchronizing <member name>

Displayed by the master to indicate that it is resynchronizing the specified member (member).

Info Message Resynchronization from Master in progress.

Displayed by the member to indicate the master is in the process of resynchronizing it.

Info Message Resynchronization complete.

Displayed by the member to indicate the resynchronization has completed successfully.

Info Message Resynchronization did not complete before timeout. Retrying.

Indicates the master did not complete the resynchronization before the member expected it to complete and that the member is re-requesting resynchronization from the master for the remaining missed transactions.

Info Message Master Selected As Partner (DEFAULT)

Displayed by the member to indicate that it has selected the master as a partner after successfully getting connected with the master. Partner selection is performed after analyzing the replication workloads on other replication members.

Info Message Initiating Replication of Transaction <transaction #> with <# of elements> Elements.

Displayed by the master to indicate that it is beginning replication of a transaction to the member.

Info Message Replication Transaction #<transaction #> With <# of elements> Elements Initiated

Displayed by the master to indicate that it has completed sending the transaction to the member.

Info Message Committing Replication of Transaction <transaction #> with <# of elements> Elements.

Displayed by the member to indicate that it has received a transaction and is processing it.

Info Message Replication Transaction #<transaction#> With <# of element> Elements Committed

Displayed by the member to indicate that the transaction has been successfully processed.

Info Message Stopping Replication Manager

Displayed at shutdown by both the master and member to indicate the replication manager is being shut down.

Info Message Stopping Replication Manager - waiting for replication to complete...

Displayed by the member when a shutdown is attempted while received replications are being processed. After the replications are complete, the shutdown will complete.

Info Message Replication in progress. Please wait...

Periodically displayed while a shutdown is pending and replications are being completed.

Info Message Replication Manager Stopped

Displayed by both the master and member to indicate the replication manager has been successfully shutdown.

Warning Log Messages

Warning Message Transaction Sync not received within configured TransactionSyncInterval. Communication with the Master may not be possible.

The member displays this log messages to indicate that it has not received a TransactionSync message from the master within its configured TransactionSync interval.

Warning Message TXN_SYNC Received by Master from unknown member <ip address>. Validation Failed

Displayed by the master when a TransactionSync message is received by the master. Since there can be only one configured master in a replication network, and the master is the only server who can send a TransactionSync message, this indicates there is another configured master in the replication network.

Warning Message TXN_SYNC Received from unknown Master <ip address>. Validation Failed

Displayed by the member to indicate that a TransactionSync message was received from a server not configured as its master.

- Warning Message** Requesting resynchronization from Master: Last Txn#<transaction#>
Displayed by the member to indicate that it is requesting resynchronization from the master. The LastTxn# is the last transaction number the member received and processed successfully.
- Warning Message** Resynchronization Request received from unknown member.
Displayed by the master when a resynchronization request is received by a member who is not listed in its `/radius/replication/rep` members configuration.
- Warning Message** Resynchronization of <member name> requires Full Resynchronization.
Displayed by the master to indicate that the member cannot be automatically resynchronized because its last transaction number is not within the configured history length of the archive (TransactionArchiveLimit). A manual resynchronization of the member is required to put the member back in-sync.
- Warning Message** MEMBER_SYNC Received from unknown Master at <ip address>. Validation Failed
Displayed by a member indicating that a master, other than its configured master, is requesting partnership.
- Warning Message** MEMBER_SYNC Received by Master from unknown member <ip address>. Validation Failed
Displayed by the master to indicate a member not listed in its `/radius/replication/rep` members configuration has requested partnership.
- Warning Message** TXN_EXPECT Received by Master from unknown <ip address>.
Displayed by the master to indicate it has received a transaction which originated from another illegal master.
- Warning Message** TXN_EXPECT Received from unknown Master <ip address>.
Displayed by the member to indicate it has received a transaction which originated from a master other than its configured master.
- Warning Message** TXN_EXPECT Broadcast failed.
Indicates that the master could not initiate a replication.
- Warning Message** DATA_SYNC Received by Master from unknown <ip address>
Displayed by the master to indicate that it received a replication transaction from another illegal master.
- Warning Message** DATA_SYNC Received from unknown <ip address>
Displayed by the member to indicate that a transaction was received from a server external to the replication network.

Error Log Messages

- Error Message** DATA_SYNC Validation failed - CRC Mismatch
Displayed by the member to indicate a received transaction element is invalid.

Error Message TXN_SYNC: Failed To Get Member Socket Handle.
TXN_SYNC: Failed to get master's socket handle.
MEMBER_SYNC could not get socket handle
TXN_EXPECT: Failed to get socket handle.
DATA_SYNC could not get socket handle.
These messages indicate an invalid interface configuration in Cisco Access Registrar.
They could also be the result of specifying an invalid RepPort setting.
Failed To Create TXN_SYNC packet. (out of packets?)

```
Failed To Create TXN_SYNC packet.
MEMBER_SYNC Failed to create packet.(out of packets?)
MEMBER_SYNC Failed to create packet.
TXN_EXPECT Failed to create packet.(out of packets?)
TXN_EXPECT Failed to create packet.
DATA_SYNC Create packet failed.(out of packets?)
DATA_SYNC Create packet failed.
```

These message indicate that a packet could not be created. This could be the result of a low memory condition or the result of the /Radius/Advanced/ MaximumNumberOfRadiusPackets setting being set too low

```
Error Message TXN_SYNC validation failed - Internal error (pTxnSync=NULL).
MEMBER_SYNC validate failed - Internal Error (pMemberSync=NULL)
DATA_SYNC Validation Failed - Internal (pDataSync = NULL).
TXN_EXPECT Could not add new datablock to pending transaction queue.
Replication Member could not be added to member list.
Replication Member could not be added to member list.
```

These messages are the result of a failed memory allocation possibly due to an out of memory condition.

```
Error Message DATA_SYNC Packet creation failed - Invalid ordinal.
Attempt To Replicate Transaction With Zero Elements.
Internal Error - Selected member not valid
Internal Replication Error ChangeType <change type> For <element path>
Internal error - Replication manager is invalid
```

These messages indicate an internal application failure.

```
Error Message Cannot archive transaction datablock
Could not archive transaction
```

These messages are the result of a failed archive attempt. This could be the result of a low disk space condition.

```
Error Message Could not commit transaction to MCD
Cannot Get Value For Unsupported DataType <data type id>
MCD Replication Cannot Delete Value <element path>
MCD Replication Cannot Delete Directory <element path>
MCD Replication Cannot Delete Value For <element path> With Unsupported DataType
<data type id>
MCD Replication Cannot Create Dir For <element path>
MCD Replication Cannot Set Value For <element path>
MCD Replication Cannot Set Value For <element path>
MCD Replication Cannot Set Value For <element path>
MCD Replication Cannot Set Value For <element path>
MCD Replication Cannot Set Value For <element path> With Unsupported DataType
<data type id>
MCD Replication Cannot Set Value For <element path> With UNKNOWN DataType <data
type id>
```

These messages are the result of a failed replication commit attempt.

Log Messages You Should Never See

The following list contains log messages which you should never see displayed in a log. If any of these messages are displayed in the log, contact Cisco Prime AR technical support for assistance.

Error Message

```
DATA_SYNC Received from non-partner <ip address>
DATA_RE_SYNC CRC mismatch. Replying with NAK
DATA_RE_SYNC Commit Failed. Replying with NAK
EVAL_SYNC Validation failed. <ip address> is not a Master or Member of the
Replication network
EVAL_SYNC Received from unknown member.
PARTNER_SYNC Received from unknown member <ip address>.
PARTNER_SYNC Received from unknown member <ip address>.
EVAL_SYNC Cannot get socket handle.
EVAL_SYNC Failed to create packet.(out of packets?)
EVAL_SYNC Failed to create packet.
EVAL_SYNC Validation failed - Internal Error (pEvalSync=NULL).
PARTNER_SYNC Failed to get socket handle.
PARTNER_SYNC Failed to create packet. (out of packets?)
PARTNER_SYNC Failed to create packet.
DATA_RE_SYNC Can't get socket handle
DATA_RE_SYNC Failed to create packet (out of packets?)
DATA_RE_SYNC Failed to create packet
DATA_RE_SYNC Failed validation - Internal Error (pReSync = NULL)
DATA_RE_SYNC Cannot Set Value For <element path>
DATA_RE_SYNC Cannot Set Value For <element path>
DATA_RE_SYNC Cannot Set Value For <element path>
DATA_RE_SYNC Cannot Set Value For <element path>
DATA_RE_SYNC Cannot Set Value For <element path> With Unsupported DataType <data
type id>
DATA_RE_SYNC Cannot Set Value For <element path> With UNKNOWN DataType <data type
id>;
DATA_RE_SYNC Received by Master from unknown member <ip address>
DATA_RE_SYNC Received from unknown Master <ip address>DATA_RE_SYNC Reply received
by Master from unknown Member <ip address>
Could not replicate data element to partners.
Could not replicate to partners - Invalid Ordinal.
```



CHAPTER 13

Using On-Demand Address Pools

Cisco Prime Access Registrar (Cisco Prime AR) provides support for On-Demand Address Pools (ODAP). Using ODAP, the Cisco Prime AR server manages pools of addresses. Each pool is divided into subnets of various sizes, and the Cisco Prime AR server assigns the subnets to virtual home gateways (VHG) and Provider Edge (PE) routers. The VHG/PE router has one On-Demand Address Pool configured for each VPN supported by that VHG/PE.

Cisco Prime AR has been enhanced to make ODAP functionality more accessible and to enable ODAP requests and normal user authentication to occur on the same Cisco Prime AR server. To achieve this functionality, a new Cisco vendor script **CiscoWithODAPIncomingScript** was written to direct ODAP requests to particular services and session managers. **CiscoWithODAPIncomingScript** also provides the same functionality as the previous **CiscoIncomingScript**.

Additionally, Cisco Prime AR has a new vendor type, **CiscoWithODAP** which references **CiscoWithODAPIncomingScript** as its IncomingScript and references the existing script, **CiscoOutgoingScript**, as its Outgoing Script.

Figure 13-1 shows a simple MPLS VPN network with two VHG/PE routers, VHG-1 and VHG-2. The Cisco Prime AR server allocates IP subnets to the VHGs by way of VRFs which contain the subnets and addresses (address space) available.

Figure 13-1 MPLS Core

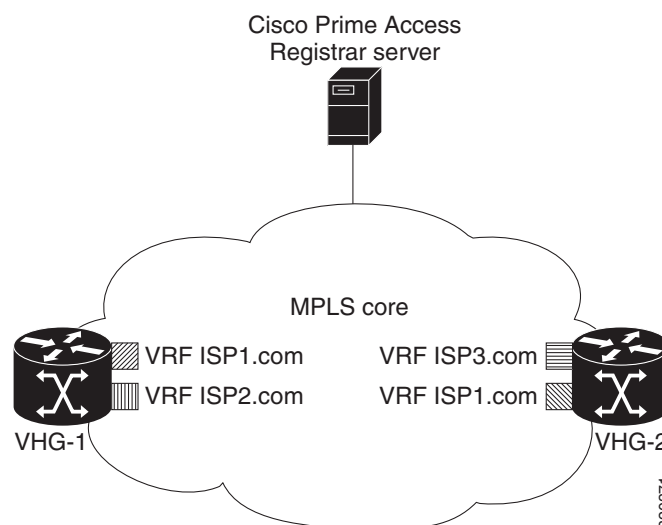

In Cisco Prime AR, the VRFs are configured as users in an ODAP-users list under **/Radius/UserLists**. The VRF name is set in IOS for the ODAP pool. When a VRF requests a pool of addresses, Cisco Prime AR directs the request to a Session-Manager configured with the name **odap-<VRF name>**. Cisco Prime AR also directs ODAP accounting requests to the service **odap-accounting**.

In the example network shown in [Figure 13-1](#), the VRFs are configured with the following address spaces:

- **VRF-ISP1.com**—consists of the address range 10.255.0.0 - 10.255.255.255 divided among the following subnets:
 - 10.255.0.0/24
 - 10.255.1.0/24
 - ...
 - 10.255.255.0/24
- **VRF-ISP2.com**—consists of the address ranges 10.0.0.0 - 10.10.255.255 and 10.255.0.0 - 10.255.10.255 divided among the following subnets:
 - 10.0.0.0/16
 - 10.1.0.0/16
 - ...
 - 10.10.0.0/16
 and:
 - 10.255.0.0/24
 - 10.255.1.0/24
 - ...
 - 10.255.10.0/24



Note VRF-ISP2.com requires two ResourceManagers because it has subnets of two different sizes.

- **VRF-ISP3.com**—consists of the address range 172.21.0.0 - 172.21.255.255 divided among the following subnets:
 - 172.21.0.0/18
 - 172.21.64.0/18
 - 172.21.128.0/18
 and
 - 172.21.192.0/24
 - 172.21.193.0/24
 - ...
 - 172.21.255.0/24



Note VRF-ISP3.com requires two ResourceManagers because it also has subnets of two different sizes.

This chapter contains the following sections:

- [Cisco-Incoming Script](#)
- [Vendor Type CiscoWithODAP](#)
- [Configuring Cisco Prime Access Registrar to Work with ODAP](#)

Cisco-Incoming Script

The **CiscoWithODAPIncomingScript** makes ODAP functionality more accessible. This script eases the configuration required to enable ODAP requests and normal user authentication to occur on the same Cisco Prime AR server. **CiscoWithODAPIncomingScript** also provides the functionality of the original **CiscoIncomingScript**.

If the Cisco Prime AR server receives an ODAP request, the server sets the Session-Key from the AcctSessionID and sets the services and session managers.

If the Cisco Prime AR server receives a non-ODAP request, other scripts, rules or policies that you might already have in place on the Cisco Prime AR server handle these requests.

This section contains the following topics:

- [How the Script Works](#)
- [CiscoWithODAPIncomingScript](#)

How the Script Works

The following describes how the script **CiscoWithODAPIncomingScript** works:

1. The script examines the incoming NAS-Identifier sent by the client (VHG). If the NAS-Identifier does not equal *odap-dhcp* then this request is not an ODAP request. Since this is not an ODAP request, the script does not do any more ODAP-specific processing and just calls **CiscoIncomingScript** to allow that script to process the request. If this is an ODAP request, this script removes the NAS-Identifier attribute because it is no longer needed.
2. The script sets the Authentication-Service and the Authorization-Service to *odap-users*, and it sets the Accounting-Service to *odap-accounting*.
3. The Cisco Prime AR server sends the request to the appropriate Session Manager based on the username. Session Managers with *odap-**<username>*** must be created and configured in Cisco Prime AR.
4. The script then uses Session IDs to identify each ODAP request. The script uses the Acct-Session-Id attribute as the Session-Key.

CiscoWithODAPIncomingScript

The following is a Tcl script example of the script **CiscoWithODAPIncomingScript**.



Note

CiscoWithODAPIncomingScript is written in C language. This example script is more easily understood in Tcl.

```

proc CiscoWithODAPIncomingScript {request response environ} {

    set RequestType [ $environ get Request-Type ]

    if { [ string compare $RequestType "Access-Request" ] == 0 ||
        [ string compare $RequestType "Accounting-Request" ] == 0 } {

        set NasID [ $request get NAS-Identifier ]

        if { [ string compare $NasID "odap-dhcp" ] == 0 } {
            # Remove the NAS-Identifier - it has done it's job
            $request remove NAS-Identifier

            set UserName [ $environ get User-Name ]
            if { [ string length $UserName ] == 0 } { set UserName [ $request get
User-Name ] }

            # ODAP SUBNET ASSIGNMENT
            $environ put Authentication-Service "odap-users"
            $environ put Authorization-Service "odap-users"
            $environ put Accounting-Service "odap-accounting"
            $environ put Session-Manager "odap-$UserName"

            set AcctSessionId [ $request get Acct-Session-Id ]
            if { [ string length $AcctSessionId ] != 0 } { $environ put Session-Key
$AcctSessionId
            } else {
                $environ log LOG_ERROR "Missing Acct-Session-Id attribute in request-unable
to set Session-Key"
            }
        }
    }
}
CiscoIncomingScript $request $response $environ
}

```

**Note**

The final line in the example above is not how the script really works because a Tcl script can't call a C script. This is one reason why **CiscoWithODAPIncomingScript** was written in C.

Vendor Type CiscoWithODAP

You must configure any Clients that might forward ODAP requests to the Cisco Prime AR server as being of Vendor **CiscoWithODAP**.

This vendor type references the new script, **CiscoWithODAPIncomingScript**, as its IncomingScript and references the existing script, CiscoOutgoingScript, as its OutgoingScript.

After setting Vendor to **CiscoWithODAP**, ODAP requests are directed to the AA service, set to *odap-users*, the accounting service is set to *odap-accounting*, and the Session Manager is set to *odap-username*, where username is filled from the request. The username received in the request is a VRF name, the request is directed to the appropriate Session Manager.

Configuring Cisco Prime Access Registrar to Work with ODAP

This section provides information about how to configure Cisco Prime AR to work with ODAP.

Configuring Cisco Prime AR to work with ODAP

You must configure any Clients that might forward ODAP requests to the Cisco Prime AR server as being of Vendor **CiscoWithODAP**.

Configuring Cisco Prime AR to work with ODAP

To configure Cisco Prime AR to work with ODAP:

-
- Step 1** Create and configure an ODAP-users UserList
All ODAP users are configured under this UserList.
 - Step 2** Add all ODAP users to the ODAP-users UserList
Usernames must be of the form `<vrf name>` with the AllowNullPassword property set to TRUE.
 - Step 3** Create and configure a service for ODAP-users
 - Step 4** Create and configure an ODAP accounting service
Set the accounting service Type to *file* and FilenamePrefix *odap-accounting*.
 - Step 5** Create a Session Manager for each of the VRFs
There must be a separate Session Manager for each VRF pool.
 - Step 6** Create and configure Resource Managers to be referenced by the Session Managers
-
-  **Note** Subnet pools of different sizes (different subnet masks) require separate Resource Managers
-
- Step 7** Configure the Session Managers with the Resource Managers
 - Step 8** Configure any Clients that might send ODAP requests to Vendor type CiscoWithODAP
 - Step 9** Save your configuration
-

Configuring the ODAP Detailed Instructions

You must configure any Clients that might forward ODAP requests to the Cisco Prime AR server as being of Vendor **CiscoWithODAP**.

Configuring the ODAP Detailed Instructions

To configure Cisco Prime AR to work with ODAP:

Setting Up an ODAP UserList

-
- Step 1** Create a UserList for ODAP users.

```
--> cd /radius/userlists
```

```
[ //localhost/Radius/UserLists ]
  Entries 1 to 1 from 1 total entries
  Current filter: <all>

  Default/

--> add odap-users

Added odap-users
```

Adding ODAP Users

- Step 2** Add the ODAP users to the ODAP UserList and set the AllowNullPassword property to TRUE. Each user is a VRF name set for each ODAP client.

```
[ //localhost/Radius/UserLists/odap-users ]

  Entries 0 to 0 from 0 total entries
  Current filter: <all>

  Name = odap-users
  Description =

--> add vrf-ISP1.com

Added vrf-ISP1.com

--> add vrf-ISP2.com

Added vrf-ISP2.com

--> add vrf-ISP3.com

Added vrf-ISP3.com

--> ls

[ //localhost/Radius/UserLists/odap-users ]
  Entries 1 to 3 from 3 total entries
  Current filter: <all>

  Name = odap-users
  Description =
  vrf-ISP1.com/
  vrf-ISP2.com/
  vrf-ISP3.com/
```

- Step 3** Set the AllowNullPassword property to TRUE for each ODAP user.

```
--> cd vrf-ISP2.com

[ //localhost/Radius/UserLists/odap-users/vrf-ISP2.com ]
  Name = vrf-ISP2.com
  Description =
```

```
    Password =
    Enabled = TRUE
    Group~ =
    BaseProfile~ =
    AuthenticationScript~ =
    AuthorizationScript~ =
    UserDefined1 =
    AllowNullPassword = FALSE

--> set AllowNullPassword TRUE
```

Setting Up an ODAP-Users Service

Step 4 Add and configure a service for ODAP Users.

```
--> cd /radius/services

[ //localhost/Radius/Services ]
  Entries 1 to 2 from 2 total entries
  Current filter: <all>

  local-file/
  local-users/

--> add odap-users

Added odap-users

--> cd odap-users

[ //localhost/Radius/Services/odap-users ]
  Name = odap-users
  Description =
  Type =
  IncomingScript~ =
  OutgoingScript~ =

--> set type local

Set Type local

--> set userlist odap-users

Set UserList odap-users

--> ls

[ //localhost/Radius/Services/odap-users ]
  Name = odap-users
  Description =
  Type = local
  IncomingScript~ =
  OutgoingScript~ =
  OutagePolicy~ = RejectAll
  OutageScript~ =
  UserList = odap-users
```

Setting Up an ODAP Accounting Service

Step 5 Add and configure an ODAP accounting service.

```
--> cd /radius/services

[ //localhost/Radius/Services ]
  Entries 1 to 3 from 3 total entries
  Current filter: <all>

  local-file/
  local-users/
  odap-users/

--> add odap-accounting

Added odap-accounting

--> cd odap-accounting

[ //localhost/Radius/Services/odap-accounting ]
  Name = odap-accounting
  Description =
  Type =
  IncomingScript~ =
  OutgoingScript~ =

--> set type file

Set Type file

--> ls

[ //localhost/Radius/Services/odap-accounting ]
  Name = odap-accounting
  Description =
  Type = file
  IncomingScript~ =
  OutgoingScript~ =
  OutagePolicy~ = RejectAll
  OutageScript~ =
  FilenamePrefix = accounting
  MaxFileSize = "10 Megabytes"
  MaxFileAge = "1 Day"
  RolloverSchedule =

--> set FilenamePrefix odap-accounting

Set Filenameprefix odap-accounting
```

Adding Session Managers

Step 6 Create one Session Manager for each of the VRF pools.

Create one Session Manager for each of the users you specify in the odap-users UserList. The Session Managers must be called odap-*VRF_name* to meet the requirements of **CiscoWithODAPIncomingScript**.

```

--> cd /radius/sessionmanagers

[ //localhost/Radius/SessionManagers ]
  Entries 1 to 1 from 1 total entries
  Current filter: <all>

  session-mgr-1/

--> add odap-vrf-ISP1.com

Added odap-vrf-ISP1.com

--> add odap-vrf-ISP2.com

Added odap-vrf-ISP2.com

--> add odap-vrf-ISP3.com

Added odap-vrf-ISP3.com

```

Setting Up Resource Managers

- Step 7** Set up subnet-dynamic Resource Managers that are to be referenced by the Session Managers. Session Managers can manage multiple Resource Managers. One or more subnet pools can be set up of varying sizes to allocate the ranges of subnet addresses you have available. Subnets of different sizes require different Resource Managers.

```

--> cd /radius/resourcemanagers

[ //localhost/Radius/ResourceManagers ]
  Entries 1 to 5 from 5 total entries
  Current filter: <all>

  IPA-Pool/
  IPA-Pool-2/
  IPX-Pool/
  Per-Group/
  Per-User/

--> add odap-vrf-ISP1.com

```



Note The names of Resource Managers do not have to be related to VRFs.

```

Added odap-vrf-ISP1.com

--> cd odap-vrf-ISP1.com

[ //localhost/Radius/ResourceManagers/odap-vrf-ISP1.com ]
  Name = odap-vrf-ISP1.com
  Description =
  Type =

--> set type subnet-dynamic

```

```
Set Type subnet-dynamic
```

```
--> ls
```

```
[ //localhost/Radius/ResourceManagers/odap-vrf-ISP1.com ]
  Name = odap-vrf-ISP1.com
  Description =
  Type = subnet-dynamic
  NetMask =
  SubnetAddresses/
```

```
--> set netmask 255.255.255.0
```

```
Set NetMask 255.255.255.0
```

```
--> cd subnetaddresses
```

```
[ //localhost/Radius/ResourceManagers/odap-vrf-ISP1.com/SubnetAddresses ]
  Entries 0 to 0 from 0 total entries
  Current filter: <all>
```

```
--> add 10.255.0.0-10.255.255.255
```

```
Added 10.255.0.0-10.255.255.255
```

Note

Two Resource Managers are required for VRF-ISP3.com and VRF-ISP2.com because their address spaces are made up of subnets of the different sizes.

```
--> cd /radius/resourcemanagers
```

```
[ //localhost/Radius/ResourceManagers ]
  Entries 1 to 5 from 5 total entries
  Current filter: <all>
```

```
  IPA-Pool/
  IPA-Pool-2/
  IPX-Pool/
  odap-vrf-ISP1.com/
  Per-Group/
  Per-User/
```

```
--> add odap-vrf-ISP3-a.com
```

```
Added odap-vrf-ISP3-a.com
```

```
--> cd odap-vrf-ISP3-a.com
```

```
[ //localhost/Radius/ResourceManagers/odap-vrf-ISP3-a.com ]
  Name = odap-vrf-ISP3-a.com
  Description =
  Type =
```

```
--> set type subnet-dynamic
```

```
Set Type subnet-dynamic
```

--> ls

```
[ //localhost/Radius/ResourceManagers/odap-vrf-ISP3-a.com ]
  Name = odap-vrf-ISP3-a.com
  Description =
  Type = subnet-dynamic
  NetMask =
  SubnetAddresses/
```

-> set netmask 255.255.192.0

Set NetMask 255.255.192.0

-> cd subnetaddresses

```
[ //localhost/Radius/ResourceManagers/odap-vrf-ISP3-a.com /SubnetAddresses ]
  Entries 0 to 0 from 0 total entries
  Current filter: <all>
```

--> add 171.21.0.0-172.21.191.255

Added 172.21.0.0-172.21.191.255

-> cd /radius/resourcemanagers

```
[ //localhost/Radius/ResourceManagers ]
  Entries 1 to 10 from 10 total entries
  Current filter: <all>
```

```
  IPA-Pool/
  IPA-Pool-2/
  IPX-Pool/
  odap-vrf-ISP1.com/
  odap-vrf-ISP3-a.com /
  Per-Group/
  Per-User/
```

--> add odap-vrf-ISP3-b.com

Added odap-vrf-ISP3-b.com

--> cd odap-vrf-ISP3-b.com

```
[ //localhost/Radius/ResourceManagers/odap-vrf-ISP3-b.com ]
  Name = odap-vrf-ISP3-b.com
  Description =
  Type =
```

--> set type subnet-dynamic

Set Type subnet-dynamic

--> ls

```
[ //localhost/Radius/ResourceManagers/odap-vrf-ISP3-b.com ]
  Name = odap-vrf-ISP3-b.com
  Description =
  Type = subnet-dynamic
```

```
NetMask =
SubnetAddresses/
```

-> set netmask 255.255.255.0

```
Set NetMask 255.255.255.0
```

-> cd subnetaddresses

```
[ //localhost/Radius/ResourceManagers/odap-vrf-ISP3-b.com /SubnetAddresses ]
  Entries 0 to 0 from 0 total entries
  Current filter: <all>
```

```
--> add 172.21.191.0-172.21.255.255
```

```
Added 172.21.191.0-172.21.255.255
```

-> cd /radius/resourcemanagers

```
[ //localhost/Radius/ResourceManagers ]
  Entries 1 to 10 from 10 total entries
  Current filter: <all>
```

```
IPA-Pool/
IPA-Pool-2/
IPX-Pool/
odap-vrf-ISP1.com/
odap-vrf-ISP3-a.com /
odap-vrf-ISP3-b.com /
Per-Group/
Per-User/
```

```
--> add odap-vrf-ISP2-a.com
```

```
Added odap-vrf-ISP2-a.com
```

--> cd odap-vrf-ISP2-a.com

```
[ //localhost/Radius/ResourceManagers/odap-vrf-ISP2-a.com ]
  Name = odap-vrf-ISP2.com
  Description =
  Type =
```

--> set type subnet-dynamic

```
Set Type subnet-dynamic
```

--> ls

```
[ //localhost/Radius/ResourceManagers/odap-vrf-ISP2-a.com ]
  Name = odap-vrf-ISP2-a.com
  Description =
  Type = subnet-dynamic
  NetMask =
  SubnetAddresses/
```

-> set netmask 255.255.0.0

```
Set NetMask 255.255.0.0
```

-> cd subnetaddresses

```
[ //localhost/Radius/ResourceManagers/odap-vrf-ISP2-a.com /SubnetAddresses ]
  Entries 0 to 0 from 0 total entries
  Current filter: <all>
```

```
--> add 10.0.0.0-10.10.255.255
```

```
Added 10.0.0.0-10.255.255.255
```

-> cd /radius/resourcemanagers

```
[ //localhost/Radius/ResourceManagers ]
  Entries 1 to 10 from 10 total entries
  Current filter: <all>
```

```
  IPA-Pool/
  IPA-Pool-2/
  IPX-Pool/
  odap-vrf-ISP1.com/
  odap-vrf-ISP3-a.com /
  odap-vrf-ISP3-b.com /
  odap-vrf-ISP2-a.com /
  Per-Group/
  Per-User/
```

```
--> add odap-vrf-ISP2-b.com
```

```
Added odap-vrf-ISP2-b.com
```

--> cd odap-vrf-ISP2-b.com

```
[ //localhost/Radius/ResourceManagers/odap-vrf-ISP2-b.com ]
  Name = odap-vrf-ISP2-b.com
  Description =
  Type =
```

--> set type subnet-dynamic

```
Set Type subnet-dynamic
```

--> ls

```
[ //localhost/Radius/ResourceManagers/odap-vrf-ISP2-b.com ]
  Name = odap-vrf-ISP2-b.com
  Description =
  Type = subnet-dynamic
  NetMask =
  SubnetAddresses/
```

-> set netmask 255.255.255.0

```
Set NetMask 255.255.255.0
```

-> cd subnetaddresses

```
[ //localhost/Radius/ResourceManagers/odap-vrf-ISP2-b.com /SubnetAddresses ]
  Entries 0 to 0 from 0 total entries
```

```

Current filter: <all>

--> add 10.255.0.0-10.255.10.255

Added 10.255.0.0-10.255.10.255

```

Configuring Session Managers



Note

It is not necessary to configure Session Managers in two instances. All SessionManager configuration can be done at one time before configuring the Resource Managers.

Step 8 Configure the Session Managers to be referenced by the Resource Managers.

```

--> cd/radius/sessionmanagers

[ //localhost/Radius/SessionManagers ]
Entries 1 to 4 from 4 total entries
Current filter: <all>

odap-vrf-ISP1.com/
odap-vrf-ISP2.com/
odap-vrf-ISP3.com/
session-mgr-1/

--> cd odap-vrf-ISP2.com

[ //localhost/Radius/SessionManagers/odap-vrf-ISP2.com ]
Name = odap-vrf-ISP2.com
Description =
AllowAccountingStartToCreateSession = FALSE
ResourceManagers/

--> cd resourcemanager

--> set 1 odap-vrf-ISP2-a.com

Set 1 odap-vrf-ISP2-a.com

--> set 2 odap-vrf-ISP2-b.com

Set 2 odap-vrf-ISP2-b.com

--> cd/radius/sessionmanagers

[ //localhost/Radius/SessionManagers ]
Entries 1 to 4 from 4 total entries
Current filter: <all>

odap-vrf-ISP1.com/
odap-vrf-ISP2.com/
odap-vrf-ISP3.com /
session-mgr-1/

--> cd odap-vrf-ISP3.com

```

```

[ //localhost/Radius/SessionManagers/odap-vrf-ISP3.com ]
  Name = odap-vrf-ISP3.com
  Description =
  AllowAccountingStartToCreateSession = FALSE
  ResourceManagers/

--> cd resourcemanagers

--> set 1 odap-vrf-ISP3-a.com

Set 1 odap-vrf-ISP3-a.com

--> set 2 odap-vrf-ISP3-b.com

Set 2 odap-vrf-ISP3-b.com

--> cd/radius/sessionmanagers

[ //localhost/Radius/SessionManagers ]
  Entries 1 to 4 from 4 total entries
  Current filter: <all>

  odap-vrf-ISP1.com/
  odap-vrf-ISP2.com/
  odap-vrf-ISP3.com/
  session-mgr-1/

--> cd odap-vrf-ISP1.com

[ //localhost/Radius/SessionManagers/odap-vrf-ISP1.com ]
  Name = odap-vrf-ISP1.com
  Description =
  AllowAccountingStartToCreateSession = FALSE
  ResourceManagers/

--> cd resourcemanagers

--> set 1 odap-vrf-ISP1.com

Set 1 odap-vrf-ISP1.com

```

Configure Clients

Step 9 For any client that might forward ODAP requests to the Cisco Prime AR server, set the Vendor property to CiscoWithODAP.

```

--> cd /radius/clients

[ //localhost/Radius/Clients ]
  Entries 1 to 2 from 2 total entries
  Current filter: <all>

  localhost/
  vhg-1/
  vhg-2/

--> cd vhg-1

```

```
[ //localhost/Radius/Clients/vhg-1 ]
  Name = vhg-1
  Description =
  IPAddress = 209.165.200.225
  SharedSecret = secret
  Type = NAS
  Vendor =
  IncomingScript~ =
  OutgoingScript~ =
  UseDNIS = FALSE
  DeviceName = a_name
  DevicePassword = password
```

```
--> set vendor CiscoWithODAP
```

```
Set Vendor CiscoWithODAP
```

Save Your Configuration

Step 10 After completing the configuration, save your changes.

```
--> save
```

```
Validating //localhost...
Saving //localhost...
```



CHAPTER 14

Using Identity Caching

Cisco Prime Access Registrar (Cisco Prime AR) software includes the identity caching feature. Cisco Prime AR runs as application layer software and can be used standalone or in conjunction with other workstations running Cisco Prime AR.



Note

The identity caching feature is available on Cisco Prime AR releases 3.5.2 and above.

Identity caching provides subscriber identity resolution services with fast access to associated subscriber identity data for service providers, enabling them to offer new services to their customers based on identity caching and context information management.

This chapter contains the following sections:

- [Overview](#)
- [Identity Caching Features](#)
- [Configuring Cisco Prime Access Registrar for Identity Caching](#)
- [Starting Identity Caching](#)

Overview

Identity caching enables Cisco equipment to gain context information about the operator's subscribers to support network functions or to enhance subscriber's experience on the operator's network.

[Figure 14-1 on page 14-2](#), Cisco Prime AR System Overview, shows the network environment where Cisco Prime AR identity caching might be used.

For example, Client Services Gateway (CSG) uses IP mapping information provided by identity caching to support post-paid content billing. Identity caching acquires subscriber information from other devices and information sources in the operator's network. The type of information provided is limited by the available information sources and is configurable by the operator, but might include information such as IP address, MSISDN, and IMSI. Identity caching does not duplicate the operator's persistent data stores. Identity caching provides a protocol-based interface through which Cisco network elements (Cisco Prime AR identity caching clients) can access subscriber information.

The Cisco Prime AR servers receive RADIUS flows from the Gateway GPRS support Node (GGSN) which acts as a type of network access station (NAS). These flows perform full AAA (authentication, authorization, and accounting). You can configure the Cisco Prime AR servers to redirect the accounting information (only) to an identity caching server to be cached. The GGSN can also be configured to direct only the RADIUS accounting information directly to the Cisco Prime AR server.

Cisco Prime AR also receives XML identity query flows from the CSM which acts as a NAS. In the event that a CSM should fail or lose its information, the information can be refreshed from the information cached in the Cisco Prime AR server.

Cisco Prime AR acquires subscriber information such as the IP address, the mobile Subscriber ISDN number (MSISDN), and the International Mobile System Identifier (IMSI) from AAA requests the Cisco Prime AR server receives, typically from the GGSN. The types of information provided is limited by the available information sources and is configurable by the operator.

Cisco Prime AR includes an XML Query Identity enhancement. Cisco Prime AR previously supported User-Name lookup based on the Framed IP address of an existing session. The XML Query Identity enhancement enables Framed IP address lookup based on the User-Name in an existing session.

Figure 14-1 Cisco Prime AR System Overview

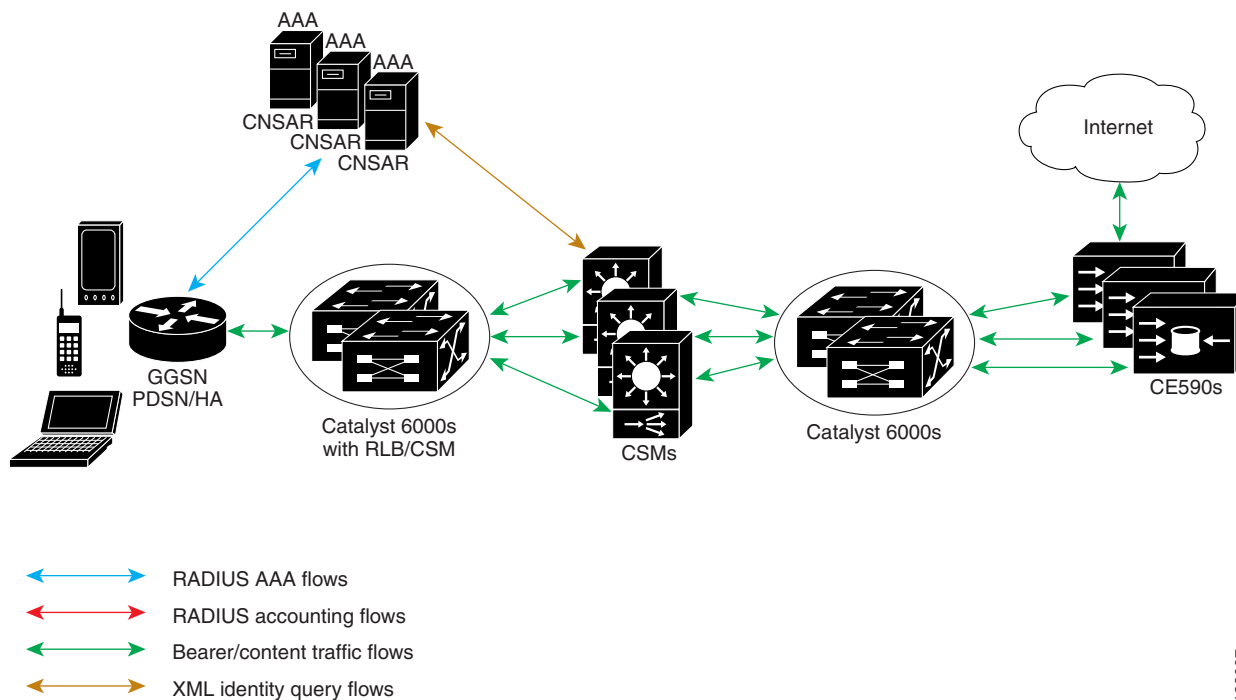

Identity Caching Features

Cisco Prime AR identity caching provides the following features:

- Supports GGSN subscriber data attributes from RADIUS authentication sequences
- Provides basic identity mapping services from IP address or username/APN to Mobile DN for one network presence at a time.
- Provide session management support for Content Switch Module (CSM)

Cisco Prime AR enables the CSM to keep the data session and content correlated to the same subscriber reconnecting, perhaps after an attach/detach sequence for a GPRS subscriber connecting again. This is done through the MSISDN identity to IP mapping in the identity caching function.

- Enhance redundancy with stateful fail-over support for applications by finding the right connection between subscriber identity and IP address using the Identity Cache function.
- Uses an XML interface to make it easier for any network function or application to use without having to have detailed internal knowledge about the execution environment or programming methods.
- Provides user identity resolution with fast access to associated subscriber data
- Establishes an identity and Access Management solution that can be used in and across multiple network domains
- Provides a way to use identity resolution to manage the growth of 2.5G mobile data access services (GSM/GPRS) and to provide always-on mobile data access including the following:
 - Ties various IP addresses to a unique subscriber identifier
 - Dynamically assigning and reusing IP addresses and controlling services with consistent identification
 - Correlates previous content activity when a mobile subscriber reconnects
 - Correlates IP addresses, mobile numbers, username, and identifiers to support customer billing
 - Correlates and identifies subscribers using both 2.5G and WLAN services and provides a way to control and manage operator network services
 - Provides subscriber privacy control
 - Provides a way to cache content with various customers and their networks

Configuring Cisco Prime Access Registrar for Identity Caching

Use the command line interface **aregcmd** to configure Cisco Prime AR to perform identity caching.

Configuring the Identity Caching

To configure identity caching:

-
- Step 1** Launch **aregcmd**.
- Step 2** Define a client object for each client that will send either RADIUS or XML packets to the Cisco Prime AR server performing identity caching.

There should be one client object for each GGSN, one for each CSM and one for each packet simulator (if used in a test environment).

For example, if a packet simulator will be used on the same server where you perform identity caching, add a client object as in the following:

```
cd /Radius/Clients
```

```
add xml-client
```

```
cd xml-client
```

```
[ //localhost/Radius/Clients/xml-client ]
Name = xml-client
Description =
IPAddress =
SharedSecret =
Type = NAS
Vendor =
IncomingScript~ =
OutgoingScript~ =
EnablePOD = FALSE
```

This client object is very similar to the localhost object defined in the example configuration. The **SharedSecret** property will be ignored if the client is an XML client, but still must be set to a non-null value. The **Type** property is also ignored for XML clients.

- Step 3** Define a port object for each RADIUS port and each XML port to be used. Two RADIUS ports, the second immediately following the first in numeric value, must be defined even if only one is needed. A typical identity caching installation requires the following port configuration:

```
cd /Radius/Advanced/Ports

add 1645

add 1646

add 8080
```



Note Although ports 1645 and 1646 are the default ports for Cisco Prime AR, you must add them to **/Radius/Advanced/Ports** to also add port 8080.

- Step 4** Change directory to the 1645 port and set its type to Radius-Access.

```
cd /Radius/Advanced/Ports/1645

set Type Radius-Access
```

- Step 5** Change directory to the 1646 port and set its type to Radius-Accounting.

```
cd /Radius/Advanced/Ports/1646

set Type Radius-Accounting
```

- Step 6** Change directory to the 8080 port and set its type to XML.

```
-cd /Radius/Advanced/Ports/8080

set Type XML
```

- Step 7** Define and configure an accounting service of type file and set it as the DefaultAccountingService.

An accounting service is required for Cisco Prime AR to cache identity information, even if no accounting service is needed otherwise. If you added the example configuration during installation, a local-file accounting service is already configured.

If you did not add the example configuration during software installation, see [Setting Up Accounting](#) section in the RADIUS Accounting chapter of the *User Guide for Cisco Prime Access Registrar, 6.0*.

Step 8 Define and configure a ResourceManager for identity caching.

```
cd /Radius/ResourceManagers
add cache
```

Step 9 Set the ResourceManager to type session-cache for identity caching.

```
cd cache
set type session-cache
```

The following shows the default properties of a session-cache ResourceManager:

```
[ //localhost/Radius/ResourceManagers/cache ]
Name = cache
Description =
Type = session-cache
OverwriteAttributes = FALSE
QueryKey =
PendingRemovalDelay = 10
AttributesToBeCached/
QueryMappings/
```

Step 10 Set the QueryKey to a RADIUS attribute you want to key on.

For example, use the following command to set the QueryKey to User-Name:

```
set QueryKey User-Name
```

The QueryKey must match the string on the right-hand side of one of the pairs you list in QueryMappings. It is not necessary for the QueryKey to be configured under **AttributesToBeCached** because the QueryKey will always be cached by default.



Note

The QueryKey property must always be a RADIUS attribute. The Cisco Prime AR server forces a NULL IP address (0.0.0.0) if it detects an incorrectly configured QueryKey.

Step 11 Change directory to **AttributesToBeCached** and use the **set** command to provide a list of RADIUS attributes you want to store in cache.

```
cd AttributesToBeCached
set 1 Calling-Station-ID
Set 2 User-Name
Set 3 Framed-IP-Address
```

The attributes a session-cache resource manager caches can be queried through both RADIUS Query and XML Query packets. When you cache attributes Framed-IP-Address or User-Name, or when you use XML-Address-format-IPv4 or XML-UserId-id_type-subscriber_id as the QueryKey, you must map the XML attributes to RADIUS attributes in the **QueryMappings** subdirectory.

Step 12 Change directory to **QueryMappings** and use the **set** command to list the attribute pairs, mapping the XML attributes on the left-hand side to the RADIUS attribute on the right-hand side.

```
set XML-Address-format-IPv4 Framed-IP-Address
```

```
set XML-UserId-id_type-subscriber_id User-Name
```

Step 13 Change directory to **/Radius/SessionManagers** and add a SessionManager for identity caching.

```
cd /Radius/SessionManagers
```

```
add IDcache
```

Step 14 Change directory to the new identity caching SessionManager, then change directory to the **ResourceManager** list.

```
cd IDcache/ResourceManagers
```

Step 15 Use the **set** command to associate the identity caching ResourceManager with this SessionManager.

```
set 1 cache
```

Step 16 Change directory to **/Radius** and set the DefaultSessionManager to the identity caching SessionManager.

```
cd /Radius
```

```
set DefaultSessionManager IDcache
```

Step 17 Run the **save**, **reload**, and **exit** commands:

```
save
```

```
reload
```

```
exit
```

Starting Identity Caching

To start identity caching, you must send an Accounting-Request to the specified accounting port (The default accounting port is 1646.) A minimal Accounting-Request will contain the following attributes:

- NAS-Identifier or NAS-IP-Address
- NAS-Port
- Framed-IP-Address
- User-Name
- Acct-Status-Type
- Acct-Session-Id

Starting Identity Caching

To start identity caching:

Step 1 Launch **radclient**:

```
cd /opt/CSCOar/bin  
  
radclient -C localhost -N admin -P aicuser
```

Step 2 Enter the following **radclient** commands:

```
set p [ acct_request Start joeuser@cisco.com ]  
  
$p set attrib [ attrib Framed-IP-Address 123.123.123.123 ]  
  
$p send
```

This assumes that you are running **radclient** on the same server and using 1646 as the accounting port.

Step 3 Send XML requests to the specified XML port (Cisco suggests port 8080 as shown above). A typical XML packet will look like the following:

```
<?xml version="1.0"?>  
<Request>  
  <UserIdRequest>  
    <UserId id_type="subscriber_id">bob</UserId>  
  </UserIdRequest>  
</Request>
```

To do this using **xmlclient**, put the XML text into a file, then enter the following command:

```
cd /opt/CSCOar/bin  
  
./xmlclient -srd <file>
```

**Note**

This assumes that **xmlclient** is running on the same server as identity caching and that 8080 is the XML port. Use the command **xmlclient -H** for information about how to use a different port or how to run **xmlclient** from a different server.

**Note**

For a successful query, xml response will have the IPAddress associated with the requested user-name and for failure query it returns 0.0.0.0 as the IPAddress.

XML Interface

The XML interface is used for subscriber context information queries and responses to those queries. The XML interface is on a UDP port (8080) and is configurable. Identity caching supports the XML data-type definition (DTD) supported by the CSG.

The mapping from queries to replies can be one to many. For example, a UDP datagram might contain several queries but each reply will be returned in a separate datagram. No single query or reply can exceed the configured MTU of a datagram. Any that does results in an error.

If a query result is negative, the reply will consist of a null subscriber ID. All other error conditions cause Cisco Prime AR to drop the request. Errors are logged locally using the Cisco Prime AR logging mechanism.



CHAPTER 15

Using Trusted ID Authorization with SESM

Cisco Prime Access Registrar (Cisco Prime AR) can be used in a Service Selection Gateway (SSG) - Cisco Subscriber Edge Services Manager (SESM) deployment to enable the Trusted Identity (Trusted ID) Authorization feature. This chapter describes how to use Cisco Prime AR with SESM, and how to configure Cisco Prime AR to use the Trusted ID feature.

The Trusted ID feature provides transparent login capabilities for users based on a trusted ID instead of the user's name, enabling end users of an SSG to maintain an always-on connection without the need to authenticate on each connect. Using SSG's Transparent Auto-Login (TAL) feature, a TAL access-request packet contains a Trusted ID, such as a MAC address, that identifies the user without the user's real username and password. The *SESM Profile Management Guide* provides detailed information about Trusted ID authorization in SESM.

If Cisco Prime AR knows the user associated with the Trusted ID, Cisco Prime AR uses the Trusted ID to authenticate and authorize the user. If the authentication and authorization succeeds, Cisco Prime AR returns the user's username in the Access-Accept so the SSG can include the user's identity in subsequent Accounting-Requests.

If Cisco Prime AR does not know the user associated with the Trusted ID, Cisco Prime AR returns an Access-Reject. The Access-Reject causes the SSG to redirect the user to a SESM web portal login page. When the user explicitly authenticates, Cisco Prime AR captures the Trusted ID and maps it to a user association so subsequent attempts to authenticate with the Trusted ID succeed.

This chapter contains the following sections:

- [Trusted ID Operational Overview](#)
- [Software Requirements](#)
- [Configuring Cisco Prime Access Registrar for Trusted Identity with SESM](#)
- [Configuration Imported by TrustedIdInstall Program](#)
- [Configuring EAP-MD5 Authentication](#)

Trusted ID Operational Overview

This section describes the following operations of the Trusted ID Authentication feature:

- [Configuration Overview](#)
- [Request Processing](#)
- [Session Cache Life Cycle](#)
- [Configuration Restrictions](#)

Configuration Overview

The Trusted ID features require two objects in Cisco Prime AR, a `UserService`, a `SessionManager`, and a `ResourceManager`. The `UserService` references another service called to perform the authentication and authorization (AA). The `SessionManager` references a `SessionManager` that contains a reference to a session-cache `Resource Manager`. These objects are imported into the Cisco Prime AR server configuration when you run the `TrustedIdInstall.bin` program. [Configuration Imported by TrustedIdInstall Program, page 15-14](#) lists the configuration imported into the Cisco Prime AR server by the `TrustedIdInstall.bin` program.

The `Resource Manager` is configured with the `QueryKey` property set to a RADIUS attribute that contains the Trusted ID such as the Calling-Station ID. The `Query Key` should be set to an attribute present in all appropriate AA requests that uniquely identifies the user such as Calling-Station ID. The `Query Key` can be set to only one RADIUS attribute.

The `Resource Manager` is also configured to cache the attributes required to identify the user, username, and the user's credentials, password or CHAP-Password and CHAP-Challenge. The attributes `User-Name`, `User-Password`, `NAS-Identifier`, `NAS-Port`, or `NAS-Port-Type` are not appropriate choices for `Query Key` because they do not uniquely identify users.

The `RollingEncryptionKeyChangePeriod` specifies the length of time a given `EncryptionKey` will be used before a new one is created. When the session-cache `ResourceManager` caches `User-Password` attributes, Cisco Prime AR encrypts the `User-Password` so it is not stored in memory or persisted on disk in clear text. Cisco Prime AR uses up to 255 encryption keys, using a new one after each `RollingEncryptionKeyChangePeriod` expires. If `RollingEncryptionKeyChangePeriod` is set to *2 days*, Cisco Prime AR will create and begin using a new `EncryptionKey` every two days. The oldest key will be retired, and Cisco Prime AR will re-encrypt any `User-Passwords` that used the old key with the new key. This way, if the `RollingEncryptionKeyChangePeriod` is set to *1 day*, no key will be older than 255 days.

The encryption keys are indirectly connected to Trusted ID. Since `User-Passwords` might be stored for a long time in memory and on disk, Cisco Prime AR uses the `RollingEncryptionKey` to encrypt the `User-Passwords`. The `RollingEncryptionKey` makes it more difficult for someone to crack or decode the `User-Passwords` because the key used changes frequently. If someone were to break one key, that would only give them the ability to decrypt those `User-Passwords` that had been encrypted with that key. All others, including those yet to be encrypted after the key change period expires would not be vulnerable.

Request Processing

When the Trusted ID service processes `Access-Requests`, it queries the session-cache `Resource Manager` for a cache entry associated with the Trusted ID. If found, the `Resource Manager` returns the cached attributes. The Trusted ID service replaces the request's existing attributes with the cached attributes.

After the `Resource Manager` is queried (and the request's existing attributes are replaced with the cached attributes if the cache entry exists), the Trusted ID's `UserService` authenticates and authorizes the request. The `UserService` is always called whether the cache entry exists or not. The only attributes cached in the `Resource Manager` are the ones listed in `AttributesToBeCached`. The user profile is usually not cached and is retrieved each time by the `UserService`.

Whether the request succeeds or not, the request is passed on to the service referenced by the `UserService` property. When that service completes authentication and authorization, control returns to the Trusted ID service. The session-cache might be updated if AA is successful.

Session Cache Life Cycle

Session cache management comprises adding and deleting Trusted ID to user mapping to and from the cache and is initiated from the Trusted ID service. The mapping is one-to-one mapping. For each Trusted ID, there can be only one cache entry, and conversely for each cache entry, there can be only one Trusted ID.

If a user is not presently in the session cache (the query failed), the AA done by the UserService succeeded and the internal attribute (Implicit-Auth-Enabled) was returned with a value of *true*, Cisco Prime AR adds the user to the cache. Since the AA succeeded, Cisco Prime AR assumes this is an explicit authentication by the user and the attributes required by the session-cache are present in the Access-Request.

If the user is already in the session cache (the query succeeded) and the AA done by the UserService failed, the internal attributes Implicit-Auth-Enabled was not returned, or was returned with a value other than *true*, Cisco Prime AR removes the user from the session cache.

If the user has enabled implicit authentication (and if that results in Implicit-Auth-Enabled being returned as *true*), after the first Explicit Auth (from the login page), the user will be in the cache and will always be implicitly authenticated and authorized. In this case, you can get them out of the cache three ways:

- Have the user disable implicit authentication, then reconnect
- Have the system administrator release the session using **aregcmd** commands
- Use the SessionTimeout property in the Session Manager

If the user's account becomes orphaned (the user no longer exists), the cache entry will persist until it is removed using **aregcmd**.

If you have disabled implicit authentication, you are forced to authenticate each time and the cache is not updated. If you subsequently enable implicit authentication, you must explicitly authenticate one more time to create the user's cache entry. After creating the user's cache entry, they will not need to explicitly authenticate again (with this instance of Cisco Prime AR) as long as implicit authentication is enabled.

Configuration Restrictions

The Session Manager referenced by the TrustedID Service should not be used for general session management. The Trusted ID Session Manager should be a separate Session Manager used only for the Trusted ID session cache. The data in the session-cache must persist longer than the length of the session. If the Trusted ID Session Manager was used for general session management, the cache would be updated for the general session, overwriting the cache entry for the special session created for the Trusted ID service. When the general session ended it would delete that data and subsequent queries for implicit authentication would fail.

Software Requirements

The Trusted ID feature requires the following software to be installed:

- Cisco Subscriber Edge Services Manager (SESM) 3.3(1)
- Cisco Subscriber Policy Engine (SPE) 2.1.12
- Cisco Prime AR

In addition to the software listed above, you must run the **TrustedIdInstall.bin** standalone, Java application that runs on the Solaris platform. **TrustedIdInstall.rpm** is an equivalent Java application that runs on the Linux platform.

**Note**

The disk space required to run the **TrustedIdInstall** program is about 1.3 MB.

The **TrustedIdInstall** program verifies the software prerequisites, installs the required jar files, and extends the configuration for Cisco Prime AR. The **TrustedIdInstall** program is only available on Cisco.com under the Cisco Prime AR download area at the following URL:

<http://www.cisco.com/cgi-bin/tablebuild.pl/access-registrar-encrypted>

This section contains the following topics:

- [Installing Cisco Prime Access Registrar](#)
- [Running the TrustedIdInstall Program](#)

Installing Cisco Prime Access Registrar

See the *Cisco Prime Access Registrar Installation and Configuration Guide, 6.0* for detailed information about how to install Cisco Prime AR software.

**Note**

You must specify a Java Runtime Environment (JRE) when you install Cisco Prime AR software.

Running the TrustedIdInstall Program

Cisco provides a Java-based program called **TrustedIdInstall** that installs required jar files, the configuration for Subscriber Policy Engine (SPE), and Cisco Prime AR. The **TrustedIdInstall** program can be run as an InstallShield wizard using the graphical user interface (GUI) or from the command line.

**Note**

Before running the **TrustedIdInstall** program, ensure that the SPE 2.1.12 software has been installed with SESM 3.3(1) (in SPE mode).

Using the TrustedIdInstall.bin GUI

You must run the **TrustedIdInstall** program on the workstation where Cisco Prime AR is installed with a Java Runtime Environment (JRE) up to and including 1.4.2 in the path.

Installing the TrustedIdInstall

To install **TrustedIdInstall**:

-
- Step 1** Log in as a user with root privileges.
- Step 2** Enter the following from the Cisco Prime AR server's command line:

TrustedIdInstall.bin (for the Solaris platform) or

TrustedIdInstall.rpm (for the Linux platform)

The following message appears after you enter the command line above:

```
# TrustedIdInstall.bin
InstallShield Wizard

Initializing InstallShield Wizard...

Searching for Java(tm) Virtual Machine...
.....running under 1.2
```

Figure 15-1 shows the welcome window of the Trusted ID Azn AR SESM Integration 1.0 Installer.

Figure 15-1 Trusted ID Azn AR SESM Integration 1.0 Installer Welcome



Step 3 Click **Next** to continue.

The **InstallIdInstall.bin** wizard displays the Prerequisites window.

Step 4 Check to ensure that Cisco SESM 3.3(1) is installed and available on the network, then click **Next**.

The **InstallIdInstall.bin** wizard checks for Cisco Prime AR 5.1 software. You will need the SESM 3.3(1) configuration parameters later in this procedure.

Step 5 Select the vendor name of the LDAP data store you are using for SPE, then click **Next**.

The **InstallIdInstall.bin** wizard displays the Password Encryption Panel. This panel prompts you for a master password (entered twice to ensure accuracy) and a Password Encryption Algorithm which can be None, SHA, or SHA-1.



Note If you plan to use EAP-MD5 authentication, choose **None**. See [Configuring EAP-MD5 Authentication](#), page 15-15 for information about configuring EAP-MD5 authentication.

Step 6 Enter the password in field provided, and select the password encryption type, then click **Next**.

Step 7 If in **Step 5** you selected iPlanet as the Data Store Type, continue with **Step 8**. If you chose any other Data Store Type, proceed to **Step 9**.

The iPlanet Data Store Type requires that you set the value for the naming variable in **ACNSchema.xml** and **DESSSchema.xml**, either for **Uid** or **Cn** as shown in [Figure 15-2](#). You can set the naming variable to either **Uid** or **Cn**.

Figure 15-2 Selecting iPlanet Naming Variable



Step 8 Select either **Uid** or **Cn** as the **inetOrgPerson** naming variable, then click **Next**.

The **InstallIdInstall.bin** wizard displays the Service Type Selection panel.

Step 9 Accept the default Trusted ID Service Enable **True** or click to select **False**, then click **Next**.

The **TrustedIdInstall** program displays a panel that indicates the following:

- Location where the Trusted ID Authorization SESM Integration files will be stored (**/cisco-ar**)
- Features to be stored (Admin Tool)
- Amount of space required (about 1.3 MB)

The **InstallIdInstall.bin** wizard displays the Directory Information panel, requesting information about the directory server required to extend the schema.

Step 10 Provide the requested Directory Server information as shown in [Figure 15-3](#).

Figure 15-3 Directory Server Information

Trusted ID Azn AR SESM Integration 1.0 Installer

Enter Directory server information for extending schema:

Directory Address: localhost

Directory Port: 389

Directory Admin User: uid=admin,ou=Administrators,ou=1

Directory Admin Password: [Empty]

Directory Container: o=cisco

DESS Admin User: cn=dessadmin,o=cisco

DESS Admin Password: [Empty]

The Directory Info Panel expects you to enter information about the directory server where the SPF Schema needs to be

Next > Cancel

InstallShield

129470

Contact the directory administrator if you are unsure about the information required.

a. Enter a **Directory Address**.

The Directory Address field requires the directory server IP address or DNS hostname.

b. Enter a **Directory Port** number.

Provide the TCP/IP port on which your directory server listens. (This is usually port 389.)

c. Enter a **Directory Admin User**.

Provide the User ID of the directory server administrator with permissions to extend the schema in the form:

cn=admin

d. Enter a **Directory Admin Password**.

Provide the password for the directory administrator user.

e. Enter a **Directory Container**.

Provide the container in which the default RBAC objects should be created in the form:

ou=sesm,o=cisco

f. Enter a **DESS Admin User**.

Provide the User ID of the DESS administrator in the form:

uid=admin,ou=sesm,o=cisco

g. Enter a **DESS Admin Password**.

Provide the password for the DESS administrator.

Step 11 Click **Next** to continue.

The **InstallIdInstall.bin** wizard begins the installation and displays a progress bar. When the installation completes, the wizard displays any warnings or errors it might have detected. Both boxes being empty indications a successful install.

Step 12 Click **Next** to continue.

A final window indicates a successful installation of the Trusted ID Authorization AR SESM Integration software.

Step 13 Click **Finish**.

Using the TrustedIdInstall Command Line

You can run the **TrustedIdInstall** program using the command line option on a workstation where Cisco Prime AR is installed with a JRE up to and including 1.4.2 in the path. The command line interface requires the same information as the GUI method.



Note

You must be a root user to run the **TrustedIdInstall** program

Installing the TrustedIdInstall using Command Line

To install TrustedIdInstall using command lin:

Step 1 To run the **TrustedIdInstall** program using the command line interface, enter the following from the Cisco Prime AR server's command line:

TrustedIdInstall.bin -console (for the Solaris platform)

TrustedIdInstall.rpm -console (for the Linux platform)

```
InstallShield Wizard
```

```
Initializing InstallShield Wizard...
```

```
Searching for Java (tm) Virtual Machine...
```

```
.....
```

```
-----
```

```
Welcome to the InstallShield Wizard for Trusted ID Azn AR SESM Integration.
```

```
The InstallShield Wizard will install Trusted ID Azn AR SESM Integration
on your computer.
```

```
To continue, choose Next.
```

```
Trusted ID Azn AR SESM Integration1.0
```

```
Cisco Systems, Inc.
```

```
http://www.cisco.com
```

```
Press 1 for Next panel, 3 to Cancel or 4 to Redisplay [1] 1
```

The line above provides a way for you to enter your selection. You can press **Enter** to go to the next panel. Enter 3 to cancel the installation, or enter 4 to redisplay the current panel.

Step 2 Press **Enter** to go to the next panel.

```
-----
```

```
Please read the information below.
```

```
Cisco Systems
```

```
Prerequisites
```

```
Please ensure that minimally the following products are installed.
```

```
1 Check to ensure that Cisco SESM 3.3(1) is installed and available on the
```



```
network
2 Checking for Cisco Prime AR 6.0 or later
Please ensure the configuration parameter supplied during SESM installation
is used in this integration.
```

```
Press 1 for Next panel, 2 for Previous panel, 3 to Cancel or 4 to
Redisplay [1] 1
```

This panel lists prerequisites required for successful installation. Before continuing to the next panel, ensure that SESM 3.3(1) is installed and available on the network. The program checks for Cisco Prime AR 3.5.3 (or later).

Step 3 After insuring that SESM 3.3(1) is installed and available on the network, press **Enter**.

```
[X] 1 - Novell Directory Server
[ ]   - iPlanet
[ ]   - Data Communications Directory
[ ]   - IBM Directory Server
[ ]   - Active Directory Server
[ ]   - Open LDAP
```

```
Choose the Vendor for Directory ,Select 0 to exit [0]
```

```
Press 1 for Next panel, 2 for Previous panel, 3 to Cancel or 4 to
Redisplay [1]
```

This panel requests the data store type selection and indicates the Novell Directory Server is the default selection.

Step 4 Press **Enter** to select the Novell Directory Server.

You can press **2** to select iPlanet, **3** to select Data Communications Directory, **4** to select IBM Directory Server, **5** to select Active Directory Server, or **6** to select Open LDAP.

```
-----
Enter the master password for SPE
```

```
Master Password []
```

This panel requests a master password for SPE.

Step 5 Enter a password to be used as the master password for SPE and press **Enter**.

You are asked to re-enter the master password. The following panel requests an encryption algorithm and generates a secret key using the master password and selected algorithm.

```
[X] 1 - NONE
[ ]   - SHA
[ ]   - SSHA
```

```
Choose the installation type for SPE ,Select 0 to exit [0]
```

```
Press 1 for Next panel, 2 for Previous panel, 3 to Cancel or 4 to
Redisplay [1] 1
```

This panel indicates the default installation type as None. Enter “2” and press **Enter** to select SHA, or enter “3” and press **Enter** to select SSHA.



Note

If you plan to use EAP-MD5 authentication, choose **None**. See [Configuring EAP-MD5 Authentication, page 15-15](#) for information about configuring EAP-MD5 authentication.

- Step 6** If in **Step 4** you selected iPlanet as the Data Store Type, continue with **Step 7**. If you chose any other Data Store Type, proceed to **Step 8**.

```
-----
[X] 1 - Uid
[ ]  - Cn
-----
```

The iPlanet Data Store Type requires that you set the value for the naming variable in **ACNSchema.xml** and **DESSSchema.xml**, either for Uid or Cn as shown above.

- Step 7** Press **Enter** to use the naming variable to Uid, or press **2** to select Cn.

Service Type Selection panel

```
Trusted ID Service Enable
[X] 1 - True
[ ] 2 - False
```

To select a choice enter its number, or 0 when you are finished [0]:

```
Press 1 for Next panel, 2 for Previous panel, 3 to Cancel or 4 to
Redisplay [1] 1
```

The Service Type Selection panel asks if you want to enable the Trusted ID service. Enter 2 to choose to not enable the Trusted ID service.

- Step 8** Press **Enter** to enable the Trusted ID service.

```
Trusted ID Azn AR SESM Integration will be installed in the following
location:
/cisco-ar
with the following features:
Admin tool
for a total size:
1.3 MB
```

```
Press 1 for Next panel, 2 for Previous panel, 3 to Cancel or 4 to
Redisplay [1] 1
```

This panel indicates the location where the TrustedIdInstall program will write data and the amount of storage required.

- Step 9** Press **Enter** to begin writing data.

```
-----
Enter the IP Address (or) hostname of the system where the directory server is
running.
Please contact your directory administrator if you are not sure about this
information.
```

```
Please enter the host address [localhost]:
```

- Step 10** Press **Enter** to use the current system as the directory server, or enter another directory server name or IP address.

```
Enter the TCP/IP Port on which your directory server listens. Usually, the
port is 389.
Please contact your directory administrator if you are not sure about this
information.
```

```
Please enter the Port number [389]:
```

Step 11 Press **Enter** to use the default port, 389, or enter a different port number.

**Note**

Contact your directory server administrator if you are not sure about which port to use or other information required in the following steps.

Enter the User Id of the directory server with permissions to extend schema.
Please contact your directory administrator if you are not sure about this information.

```
Please enter directory user  
[uid=admin,ou=Administrators,ou=TopologyManagement,o=NetscapeRoot]:
```

Step 12 Enter the User ID of the directory server administrator with the necessary permissions to extend the schema.

Enter the password for the above user.
Please contact your directory administrator if you are not sure about this information.

```
Please enter the password []: cisco
```

Step 13 Enter the password for the user provided in the previous step.

Enter the container in which the default RBAC objects should be created.
Please contact your directory administrator if you are not sure about this information.

```
Please enter the container [o=cisco]:
```

Step 14 Press **Enter** to use the default container, or enter a different container and press **Enter**.

Enter the User Id of the DESS user.

```
Please enter Dess user [cn=dessadmin,o=cisco]:
```

Step 15 Press **Enter** to use the default DESS user, or enter a different user ID and press **Enter**.

Enter the password of the DESS user.
Please contact your directory administrator if you are not sure about this information.

```
Please enter the Dess user password []: cisco
```

Step 16 Enter the DESS user password, then press **Enter**.

```
Press 1 for Next panel, 3 to Cancel or 4 to Redisplay [1] 1
```

At this point, the software installation is ready to begin.

Step 17 Press **Enter** to begin the software installation and extend the schema.

As the installation proceeds, status messages will be displayed.

When the installation completes successfully, the following message displays:

```
Trusted ID Azn AR SESM Integration 1.0 installation completed

The InstallShield Wizard has successfully installed Trusted ID Azn AR SESM
Integration. Choose Finish to exit the wizard.

Press 3 to Finish or 4 to Redisplay [3] 3
```

Step 18 Press **Enter** to end the program.

Configuring Cisco Prime Access Registrar for Trusted Identity with SESM

Use the command line interface **aregcmd** to configure Cisco Prime AR to use Trusted ID authorization in SSG-SESM deployments.

This section contains the following topics:

- [Configuring the RADIUS Ports](#)
- [Configuring NAS Clients](#)
- [Configuring AAA and SPE Services](#)

Configuring the RADIUS Ports

By default, Cisco Prime AR listens on ports 1645 and 1646 for any type of RADIUS request. It might be necessary to change the port assignments in the case of a resource collision. For example, if the RADIUS Directory Enabled Service Selection (DESS) Proxy (RDP) component of SPE is using ports 1645 and 1646, a port assignment change would be required.

The following command sequence causes Cisco Prime AR to listen on the explicitly defined ports, 1812 and 1813, for all types of RADIUS requests.

```
cd /Radius/Advanced/Ports
```

```
add 1812 ""radius
```

```
Added 1812
```

```
add 1813 ""radius
```

```
Added 1813
```

After changing the port assignments, Cisco Prime AR no longer listens on the default ports. It might be necessary to add ports 1645 and 1646 if you are also using Cisco Prime AR for other AAA functionality.

**Note**

By default, Cisco Prime AR listens on ports 1645 and 1646 on Solaris platforms and on ports 1812 and 1813 for the Linux platform.

Configuring NAS Clients

Change directory to **/Radius/Clients**, then add and configure the NAS clients required by SESM deployments:

```
cd /Radius/Clients

add SESM1 "" 10.3.3.2 cisco

Added SESM1

add SESM2 "" 10.3.3.101 cisco

Added SESM2

add SESM3 "" 10.3.3.102 cisco

Added SESM3
```

Configuring AAA and SPE Services

To configure AAA and SPE services:

Step 1 Change directory to **/Radius/Services**, then add and configure an accounting service.

```
cd /Radius/Services

add SESMaccounting "" file

Added SESMaccounting
```

Step 2 Change directory to **/Radius**, then configure a DefaultAccountingService.

```
cd /Radius

set DefaultAccountingService SESMaccounting

Set DefaultAccountingService SESMaccounting
```

Configuration Imported by TrustedIdInstall Program

The following is a listing of the configuration imported into the Cisco Prime AR server when you run the TrustedIdInstall program:

- [/Radius](#)
- [/radius/services/spe](#)
- [/radius/services/trusted-id](#)
- [/Radius/SessionManagers/session-cache/](#)
- [/radius/ResourceManagers/session-cache](#)
- [/radius/advanced/](#)
- [/Radius/Scripts/ChangeServiceType](#)

/Radius

```
DefaultAuthenticationService trusted-id
DefaultAuthorizationService trusted-id
```

/radius/services/spe

```
type java
ClassName com.cisco.cns.security.arspe.SPEExtension
```

/radius/services/trusted-id

```
type trusted-id
UserService spe
SessionManager session-cache
```

/Radius/SessionManagers/session-cache/

```
AllowAccountingStartToCreateSession FALSE
ResourceManagers/1 session-cache
```

/radius/ResourceManagers/session-cache

```
type session-cache
OverwriteAttributes TRUE
PendingRemovalDelay 10
QueryKey Calling-Station-ID
AttributesToBeCached/1 User-Name
AttributesToBeCached/2 User-Password
AttributesToBeCached/3 Calling-Station-ID
```

/radius/advanced/

```
ClasspathForJavaExtensions /cisco-ar/conf
```

/Radius/Scripts/ChangeServiceType

```
Language TCL
Filename ChangeServiceType.tcl
EntryPoint ChangeServiceType
IncomingScript ChangeServiceType
```

Configuring EAP-MD5 Authentication

EAP-MD5 authentication is an optional authentication configuration. The following configuration changes are required to support EAP-MD5 authentication:

- [Creating the CheckEap.tcl Script](#)
- [Adding the CheckEap.tcl Script](#)
- [Using the CheckEap.tcl Script](#)
- [Adding the EAP-MD5 Authentication Service](#)
- [Adding an LDAP Remote Server](#)
- [Adding an LDAP Service](#)
- [Saving the Configuration and Reloading the Server](#)
- [Cisco SSG VSAs in Cisco Prime Access Registrar Dictionary](#)

**Note**

If you configure Cisco Prime AR to use EAP-MD5 authentication with the Trusted ID feature, you will not be able to use the Transparent Auto Login feature.

Creating the CheckEap.tcl Script

The **CheckEap.tcl** script must be created and stored in the file called **/cisco-ar/scripts/radius/tcl/CheckEap.tcl**. Use a text editor and copy the following lines into the **CheckEap.tcl** file:

```
proc CheckEap { request response environment } {
    if { [ $request containsKey EAP-Message ] } {
        $environ put Authentication-Service "EAP-MD5"
        $environ put Authorization-Service "spe"
    }
}
```

Adding the CheckEap.tcl Script

To add the CheckEap.tcl script:

Step 1 Start **aregcmd**, then change directory to **/Radius/Scripts** and add the CheckEap script.

```
cd /Radius/Scripts
```

```
add EapCheck
```

Step 2 Change directory to **EapCheck**.

```
cd EapCheck
```

```
[ //localhost/Radius/Scripts/EapCheck ]
  Name = EapCheck
  Description =
  Language =
```

Step 3 Set the Language property to TCL.

```
set Language TCL
```

```
Set Language TCL
```

Step 4 Set the filename property to CheckEap.tcl.

```
set Filename CheckEap.tcl
```

```
Set Filename CheckEap.tcl
```

Step 5 Set the EntryPoint property to CheckEap.

```
set EntryPoint CheckEap
```

```
Set EntryPoint CheckEap
```

**Note**

The following sections also require you to use **aregcmd**, the command line interface.

Using the CheckEap.tcl Script

This section describes how to configure Cisco Prime AR to use the CheckEap script by setting the **/Radius/IncomingScript** property to CheckEap.

```
cd /Radius
```

```
set IncomingScript EapCheck
```

Adding the EAP-MD5 Authentication Service

To add and configure the EAP-MD5 service:

-
- Step 1** Change directory to **/Radius/Services** and add an EAP-MD5 service.

```
cd /Radius/Services
add EAP-MD5
```

- Step 2** Change directory to the EAP-MD5 service and set the Type and UserService properties as shown below:

```
cd EAP-MD5
```

- Step 3** Change directory to the EAP-MD5 service.

```
cd EAP-MD5
```

- Step 4** Set the service Type property to eap-md5 and the UserService property to LDAP.

```
set Type eap-md5
set UserService LDAP
```

The following example shows the configuration of the EAP-MD5 service:

```
[ //localhost/Radius/Services/EAP-MD5 ]
Name = EAP-MD5
Description =
Type = eap-md5
IncomingScript~ =
OutgoingScript~ =
AuthenticationTimeout = 120
UserService = LDAP
```

Adding an LDAP Remote Server

Cisco Prime AR adds a new type of service and remote server called ldap-accounting that enables inserting accounting records into LDAP. You can write accounting records into LDAP by referring this service in **/Radius/DefaultAccountingService** or in the **Accounting-Service** environment variable.

Adding and Configuring an LDAP Remote Server

To add and configure an LDAP remote server:

-
- Step 1** Change directory to **/Radius/RemoteServers** and add a RemoteServer object.

```
cd /Radius/RemoteServers
add LDAP
```

- Step 2** Change directory to the LDAP RemoteServer.

cd LDAP

```
[ //localhost/Radius/RemoteServers/LDAP ]
  Name = LDAP
  Description =
  Protocol =
```

Step 3 Set the RemoteServer protocol property to ldap.

set Protocol ldap

The following example shows the default configuration of an LDAP remote server:

```
[ //localhost/Radius/RemoteServers/LDAP ]
  Name = LDAP
  Description =
  Protocol = ldap
  Port = 389
  ReactivateTimerInterval = 300000
  Timeout = 15
  HostName =
  BindName =
  BindPassword =
  UseSSL = FALSE
  SearchPath~ =
  Filter~ = (uid=%s)
  UserPasswordAttribute = userpassword
  LimitOutstandingRequests = FALSE
  MaxOutstandingRequests = 0
  MaxReferrals = 0
  ReferralAttribute =
  ReferralFilter =
  PasswordEncryptionStyle = Dynamic
  EscapeSpecialCharInUserName = FALSE
  DNSLookupAndLDAPRebindInterval =
  LDAPToRadiusMappings/
  LDAPToEnvironmentMappings/
  LDAPToCheckItemMappings/
```

Step 4 Set the HostName property to the SPE/DESS directory IP address or hostname.

Step 5 Set the BindName property to the SPE/DESS administrator name.

Step 6 Set the BindPassword property to the SPE/DESS administrator password.

Step 7 Set the SearchPath property to the SPE/DESS directory container.

Step 8 Set the UserPasswordAttribute property type to clearpassword.

Adding an LDAP Service

You must configure a service of type ldap-accounting under /Radius/Services using the ldap accounting feature.

Adding and Configuring an LDAP Service

To add and configure an LDAP service:

Step 1 Change directory to /Radius/Service and add LDAP.

```
cd /Radius/Service
```

```
add LDAP
```

Step 2 Change directory to LDAP and set the type property to ldap.

```
cd LDAP
```

```
set Type ldap
```

The following shows the default configuration for an LDAP service:

```
[ //localhost/Radius/Services/LDAP ]
  Name = LDAP
  Description =
  Type = ldap
  IncomingScript~ =
  OutgoingScript~ =
  OutagePolicy~ = RejectAll
  OutageScript~ =
  MultipleServersPolicy = Failover
  RemoteServers/
```

Step 3 Change directory to RemoteServers and associate the LDAP RemoteServer with the LDAP service.

```
cd RemoteServers
```

```
set 1 LDAP
```

Saving the Configuration and Reloading the Server

Use the **save** command to save the configuration, then **reload** the Cisco Prime AR server.

```
save
```

```
Validating //localhost...
Saving //localhost...
```

```
reload
```

```
Reloading Server 'Radius'...
Server 'Radius' is Running, its health is 10 out of 10
```

Cisco SSG VSAs in Cisco Prime Access Registrar Dictionary

The following vendor-specific attributes (VSAs) are defined by default in the attribute dictionary after installing Cisco Prime AR software:

- Cisco-AVPair
- Cisco-SSG-Account-Info
- Cisco-SSG-Service-Info
- Cisco-SSG-Command-Code
- Cisco-SSG-Control-Info



CHAPTER 16

Using Prepaid Billing

Cisco Prime Access Registrar (Cisco Prime AR) supports two types of prepaid billing, IS835C and Cisco Real-time Billing (CRB), a Cisco proprietary solution. The IS835C version adheres to industry standards and is the preferred version.

Three components are required to support a prepaid billing service, such as the following:

- AAA client
- Cisco Prime AR server
- External prepaid billing server

The most important factor for an effective prepaid billing service is in developing a shared library to be configured under the prepaid RemoteServer object. The shared library should be developed to implement all specified API functions. You will have to provide a shared library that meets the needs of your environment. The shared library must implement the API functions to perform the various tasks required for your specific implementation of the prepaid billing service.



Note

Cisco works with you to develop the prepaid billing service and implement the API. For more information, contact your Cisco systems engineer.

The chapter contains the following sections:

- [Overview](#)
- [IS835C Prepaid Billing](#)
- [CRB Prepaid Billing](#)
- [Implementing the Prepaid Billing API](#)

Overview

When a subscriber uses a prepaid billing service, each call requires a set of data about the subscriber. However, the AAA network has no previous knowledge of the subscriber's usage behavior. Cisco Prime AR uses an iterative authorization paradigm over multiple sessions to support the prepaid billing solution.

Each time an authorization request is made, the billing server apportions a fraction of the subscriber's balance into a quota. When a subscriber uses multiple sessions, each session must obtain its own quota. When a previously allocated quota is depleted, a session must be reauthorized to obtain a new quota.

**Note**

The granularity and the magnitude of the quota is in the design and implementation of the prepaid billing server and is beyond the scope of this document. In general, a smaller quota generates more network traffic, but allows more sessions per subscriber. When the quota is equal to a subscriber's total account balance, there is minimal network traffic, but only one session can be supported.

When a subscriber's current quota is depleted, the AAA client initiates a reauthorization request sending Access-Request packets. After the Cisco Prime AR server receives the request, it forwards the request to the billing server. The billing server then returns the next quota to use. The new quota might not be the same as the previous, and the billing server might adjust the quota dynamically.

IS835C Prepaid Billing

Cisco Prime AR acts as a RADIUS protocol head for all the requirements specified in the *cdma2000 Wireless IP Network Standard: PrePaid Packet Data Service* specification:

http://www.3gpp2.org/Public_html/specs/X.S0011-006-C-v1.0.pdf

As long as the prepaid client understands or accepts what the external billing server sends, the service should work. The Cisco Prime AR server neither imposes nor is affected by the values of attributes returned from the external billing server.

For additional information, see *cdma2000 Wireless IP Network Standard: Accounting Services and 3GPP2 RADIUS VSAs* at the following URL:

http://www.3gpp2.org/Public_html/specs/X.S0011-005-C-v1.0.pdf

The IS835C specification requires that the Cisco Prime AR server be able to determine that a particular user is a prepaid billing user. A user is accepted as a valid prepaid user when the response dictionary of the incoming packet contains the Cisco Prime AR internal subattribute named *prepaid*.

The IS835C specification requires prepaid users to first be authenticated by the RADIUS server. This requires the configuration of a group service with an authentication service first, followed by the prepaid service that adds prepaid attributes as shown in [Setting Up an Authentication Group Service, page 16-5](#). The group service configuration enables the AA service to add the prepaid subattribute to the response dictionary upon successful authentication, before the prepaid service is invoked.

Configuring IS835C Prepaid Billing

To configure an IS835C prepaid billing service, use the following sections to configure the required Cisco Prime AR objects:

- [Setting Up a Prepaid Billing RemoteServer](#)
- [Setting Up an IS835C Prepaid Service](#)
- [Setting Up Local Authentication](#)
- [Setting Up an Authentication Group Service](#)

Setting Up a Prepaid Billing RemoteServer

Cisco Prime AR loads the library dynamically and registers the API functions, then calls out the library initialization API once at startup. The call to initialize functions initializes various data structures and connections with the billing server, as required.

Table 16-1 lists and describes the properties required for an IS835C RemoteServer object.

Table 16-1 *Prepaid-IS835C RemoteServer Properties*

Property	Description
Filename	Name of the shared library provided by the billing server vendor, such as libprepaid.so
IPAddress	IP address of the billing server
Port	Port used on the billing server, such as port 66
Connections	Number of threads the prepaid service and billing server can each use (default is 8).

Setting up a Prepaid Billing Remote Server

To set up a prepaid billing remote server:

Step 1 Use **aregcmd** to add a RemoteServer under **/Radius/RemoteServers**.

```
cd /radius/remoteserver
add prepaid-is835c
```

Step 2 Set remoteserver protocol to prepaid-is835c.

```
cd prepaid-is835c
set protocol prepaid-is835c

Set Protocol prepaid-is835c
```

The following is the default configuration of a prepaid-is835c RemoteServer.

```
[ //localhost/Radius/RemoteServers/prepaid-is835c ]
Name = prepaid-is835c
Description =
Protocol =
```

```
IPAddress =  
Port = 0  
Filename =  
Connections = 8
```

Setting Up an IS835C Prepaid Service

Cisco Prime AR uses a service type **prepaid** to support the prepaid billing solution. The prepaid service mediates between the client NAS and the external prepaid billing server.

Setting up an IS835C Prepaid Service

To set up an IS835C prepaid service:

Step 1 Use **aregcmd** to add a prepaid service under **/Radius/Services**:

```
cd /radius/services  
  
add prepaid  
  
Added prepaid
```

Step 2 Set the service type to prepaid.

```
cd prepaid  
  
set type prepaid  
  
Set Type prepaid
```

A prepaid service has the following default properties:

```
[ //localhost/Radius/Services/prepaid ]  
Name = prepaid  
Description =  
Type = prepaid  
IncomingScript~ =  
OutgoingScript~ =  
OutagePolicy~ = RejectAll  
OutageScript~ =  
MultipleServersPolicy = Failover  
RemoteServers/
```

Step 3 Add a reference to the is835c-prepaid RemoteServer.

```
cd RemoteServer  
  
add 1 prepaid-is835c  
  
Added 1
```

Setting Up Local Authentication

If you use the Cisco Prime AR server for authentication and authorization in your prepaid billing solution, you should configure an AA service. For example, you might configure a service similar to **local-users** (in the example configuration) for authentication and authorization of local users.

If some of the users are non-prepaid users or if the prepaid users need to have RADIUS authorization attributes returned, you should configure an AA service to perform that authentication and authorization.

Setting up a Local Authentication

To set up a local authentication:

Step 1 Use **aregcmd** to set up a local authentication service.

```
cd /radius/services

add Prepaid-LocalAuthentication

Added prepaid-LocalAuthentication

cd prepaid-LocalAuthentication

[ //localhost/Radius/Services/prepaid-LocalAuthentication ]
  Name = prepaid-LocalAuthentication
  Description =
  Type =
```

Step 2 Set the service type to local.

```
set type local

Set Type local
```

Step 3 Set the **UserList** property to the userlist that contains IS835C prepaid users.

```
set UserList userlist_name

Set UserList userlist_name
```



Note You can use an LDAP or ODBC service in place of the local authentication service.

The authentication service must add the Cisco Prime AR internal attribute *prepaid* (subattribute 22) to the response upon successful authentication.

Setting Up an Authentication Group Service

Your prepaid billing solution usually requires a group service to tie together an AA service with a prepaid service, a group service to tie together an accounting service with a prepaid service, or both.

If you are using an AA service with your prepaid billing solution, you must configure a group service, for example **prepaid-users**, that ties the requests to the AA service (**local-users** in our example) with the prepaid service.

If you are using Cisco Prime AR for an accounting service with your prepaid billing solution, you must configure a group service, for example **prepaid-file**, that ties accounting requests to both the regular accounting service (**local-file** in our example) and the prepaid service.

Setting up an Authentication Group Service

To set up an authentication group service:

Step 1 Use **aregcmd** to add a prepaid authentication group service under **/Radius/Services**.

```
cd /radius/services
```

```
add prepaid-groupAuthentication
```

```
Added prepaid-groupAuthentication
```

```
cd prepaid-groupAuthentication
```

```
[ //localhost/Radius/Services/prepaid-groupAuthentication ]
  Name = group-prepaidAuthentication
  Description =
  Type =
```

Step 2 Set the service type to group.

```
set type group
```

```
Set Type group
```

The group service requires the ResultRule to be set to AND, the default setting for a group service.

```
ls
```

```
[ //localhost/Radius/Services/group-prepaidAuthentication ]
  Name = group-prepaidAuthentication
  Description =
  Type = group
  IncomingScript~ =
  OutgoingScript~ =
  ResultRule = AND
  GroupServices/
```

Step 3 Change directory to GroupServices and add references to the prepaid service and the authentication service.

```
cd GroupServices
```

```
[ //localhost/Radius/Services/group-prepaidAuthentication/GroupServices ]
```

```
add 1 Prepaid-LocalAuthentication
```

```
Added 1
```

```
add 2 prepaid
```

```
Added 2
```

CRB Prepaid Billing

Cisco Real-Time Billing (CRB) is a Cisco proprietary method of providing prepaid billing service. Cisco Prime AR uses vendor-specific attributes (VSA) to extend the standard RADIUS protocol to carry information not usually present in the standard RADIUS packet. Cisco Prime AR uses a set of VSAs allocated to the Cisco VSA pool [26,9].

Cisco Prime AR required several different types of measurements to support a prepaid billing solution. These measurements require the use of metering variables to perform usage accounting. [Table 16-2](#) lists the different measurements and what the AAA client, Cisco Prime AR server, and billing server do with them.

Table 16-2 *Measurements and Component Actions*

Measurement Type	Billing Server Action	AAA Server Action	AAA Client Action
Duration	Return duration quota	Convert duration quota to VSAs and pass along	Compare running duration quota with quota returned by Cisco Prime AR server
Total volume	Return volume quota	Convert volume quota to VSAs and pass along	Compare running volume quota with quota returned by Cisco Prime AR server
Uplink volume	Return volume quota	Convert volume quota to VSAs and pass along	Compare running volume quota with quota returned by Cisco Prime AR server
Downlink volume	Return volume quota	Convert volume quota to VSAs and pass along	Compare running volume quota with quota returned by Cisco Prime AR server
Total packets	Return packet quota	Convert packet quota to VSAs and pass along	Compare running packet quota with quota returned by Cisco Prime AR server
Uplink packets	Return packet quota	Convert packet quota to VSAs and pass along	Compare running packet quota with quota returned by Cisco Prime AR server
Downlink packets	Return packet quota	Convert packet quota to VSAs and pass along	Compare running packet quota with quota returned by Cisco Prime AR server
Logical OR of two measurements	Return quota of both measurements	Convert both to VSA and pass along	Monitor both quota and issue reauthorization packet when any one trips

Cisco Prime AR provides maximum flexibility to billing servers by allowing the metering variable to be modified as the service is used. This requires network nodes to measure all parameters all the time, but to report values only after receiving a reauthorization request.

**Note**

If you have been using an earlier implementation of CRB prepaid billing (Cisco Access Registrar 3.5.2 or earlier), you must recompile the API implementation with the newer API due to the addition of the parameter `ebs_context` as the first parameter to all API methods. Contact your Cisco systems engineer for assistance with the new API.

This section contains the following topics:

- [Configuring CRB Prepaid Billing](#)
- [Configuring CRB Prepaid Billing for SSG](#)
- [Generic Call Flow](#)
- [Vendor-Specific Attributes](#)

Configuring CRB Prepaid Billing

To configure an CRB prepaid billing service, use the following sections to configure the required Cisco Prime AR objects:

- [Setting Up a Prepaid Billing RemoteServer](#)
- [Setting Up a CRB Prepaid Service](#)
- [Setting Up a Local Accounting Service](#)
- [Setting Up a Local Authentication Service](#)
- [Setting Up a Prepaid Accounting Group Service](#)
- [Setting Up an Authentication Group Service](#)

If you are using CRB prepaid billing with Service Selection Gateway (SSG), you must also configure extension point scripts and prepaid clients. See [Configuring CRB Prepaid Billing for SSG, page 16-15](#).

Setting Up a Prepaid Billing RemoteServer

[Table 16-3](#) lists and describes the properties required for an CRB RemoteServer object.

Table 16-3 *Prepaid-CRB RemoteServer Properties*

Property	Description
Filename	Name of the shared library provided by the billing server vendor, such as libprepaid.so
IPAddress	IP address of the billing server
Port	Port used on the billing server, such as port 66
Connections	Number of threads the prepaid service and billing server can each use (default is 8).

Setting up a Prepaid Billing Remote Server

To set up a prepaid billing remote server:

Step 1 Use **aregcmd** to add a RemoteServer under **/Radius/RemoteServers**.

```
cd /radius/remoteservers
```

```
add prepaid-crb
```

```
Added prepaid-crb
```

Step 2 Set the RemoteServer protocol to prepaid-crb.

```
cd prepaid-crb
```

```
set protocol prepaid-crb
```

```
Set Protocol prepaid-crb
```

The following is the default configuration of a prepaid-crb RemoteServer.

```
[ //localhost/Radius/RemoteServers/prepaid-crb ]
Name = prepaid-crb
Description =
Protocol =
IPAddress =
Port = 0
Filename =
Connections = 8
```

Setting Up a CRB Prepaid Service

Cisco Prime AR uses a service type **prepaid** to support the prepaid billing solution. The prepaid service mediates between the client NAS and the external prepaid billing server.

The prepaid service must receive accounting requests to accurately charge the prepaid billing user. You can also set the prepaid service in a group service to log accounting requests locally or to proxy the accounting requests to another service or to both locations.

Setting up a CRB Prepaid Service

To set up a CRB prepaid service:

Step 1 Use **aregcmd** to add a prepaid service under **/Radius/Services**:

```
cd /radius/services
```

```
add prepaid
```

```
Added prepaid
```

Step 2 Set the service type to prepaid.

```
cd prepaid
```

set type prepaid

```
Set Type prepaid
```

A prepaid service has the following default properties:

```
[ //localhost/Radius/Services/prepaid ]
Name = prepaid
Description =
Type = prepaid
IncomingScript~ =
OutgoingScript~ =
OutagePolicy~ = RejectAll
OutageScript~ =
MultipleServersPolicy = Failover
RemoteServers/
```

Step 3 Add a reference to the prepaid-crb RemoteServer.

cd RemoteServers**add 1 prepaid-crb**

```
Added 1
```



Note The following steps are required only when using Prepaid-CRB with SSG.

Step 4 Set the IncomingScript to **IncomingScript PPI-Parse-Prepaid-Incoming**.

set IncomingScript PPI-Parse-Prepaid-Incoming

```
Set IncomingScript PPI-Parse-Prepaid-Incoming
```

Step 5 Set the OutgoingScript to **OutgoingScript PPO-Parse-Prepaid-Outgoing**.

set OutgoingScript PPO-Parse-Prepaid-Outgoing

```
Set OutgoingScript PPO-Parse-Prepaid-Outgoing
```

Setting Up a Local Accounting Service

If you want to use the Cisco Prime AR server to record the accounting records locally or to forward the accounting records to another RADIUS server, you must configure an accounting service. You might configure a service similar to **local-file** (in the example configuration) for accounting requests. Accounting requests can be logged locally (with an accounting service) or remotely (with a RADIUS service).

If you use the prepaid billing server to generate the accounting records, an accounting service is not necessary.

Setting up a Local Accounting Service

To set up a local accounting service:

Step 1 Use `aregcmd` to add a local accounting service under `/Radius/Services`.

```
cd /radius/services

add prepaid-LocalFileAccounting

add prepaid-LocalFileAccounting
```

Step 2 Set the service type to file.

```
cd prepaid-LocalFileAccounting

set type file

Set Type file
```

The file type service has the following properties:

```
[ //localhost/Radius/Services/prepaid-LocalFileAccounting ]
  Name = prepaid-LocalFileAccounting
  Description =
  Type = file
  IncomingScript~ =
  OutgoingScript~ =
  OutagePolicy~ = RejectAll
  OutageScript~ =
  FilenamePrefix = accounting
  MaxFileSize = "10 Megabytes"
  MaxFileAge = "1 Day"
  RolloverSchedule =
  UseLocalTimeZone = FALSE
```

Step 3 Set the `FilenamePrefix` to `Prepaid-Accounting`.

```
set FilenamePrefix Prepaid-Accounting

Set FilenamePrefix Prepaid-Accounting
```

Step 4 Set the `MaxFileAge` to one hour.

```
set MaxFileAge "1 Hour"

Set MaxFileAge "1 Hour"
```

The `MaxFileSize` should remain at the default value of 10 megabytes.

Step 5 Set `UseLocalTimeZone` to `TRUE`.

```
set UseLocalTimeZone TRUE

Set UseLocalTimeZone TRUE
```

Setting Up a Local Authentication Service

If you use the Cisco Prime AR server for authentication and authorization in your prepaid billing solution, you should configure an AA service. For example, you might configure a service similar to **local-users** (in the example configuration) for authentication and authorization of local users.

If some of the users are non-prepaid users or if the prepaid users need to have RADIUS authorization attributes returned, you should configure an AA service to perform that authentication and authorization.

If all of the users in a realm are prepaid users and the prepaid billing client does not require normal RADIUS authorization attributes, an AA service is not necessary.

Setting up a Local Authentication Service

To set up a local authentication service:

Step 1 Use **aregcmd** to set up a local authentication service.

```
cd /radius/services
```

```
add Prepaid-LocalAuthentication
```

```
Added prepaid-LocalAuthentication
```

```
cd prepaid-LocalAuthentication
```

```
[ //localhost/Radius/Services/prepaid-LocalAuthentication ]
  Name = prepaid-LocalAuthentication
  Description =
  Type =
```

Step 2 Set the service type to local.

```
set type local
```

```
Set Type local
```

Step 3 Set the **UserList** property to the userlist that contains IS835C prepaid users.

```
set UserList userlist_name
```

```
Set UserList userlist_name
```



Note

You can use an LDAP or ODBC service in place of the local authentication service.

Setting Up a Prepaid Accounting Group Service

A prepaid billing solution usually requires a group service to tie together an AA service with a prepaid service, a group service to tie together an accounting service with a prepaid service, or both.

If you are using an AA service with your prepaid billing solution, you must configure a group service, for example **prepaid-users**, that ties the requests to the AA service (**local-users** in our example) with the prepaid service.

If you are using Cisco Prime AR for an accounting service with your prepaid billing solution, you must configure a group service, for example **prepaid-file**, that ties accounting requests to both the regular accounting service (**local-file** in our example) and the prepaid service.

Setting up a Prepaid Accounting Group Service

To set up a prepaid accounting group service:

Step 1 Use `aregcmd` to create an accounting group service under `/Radius/Services`.

```
cd /radius/services

add Prepaid-Accounting

Added prepaid-accounting
```

Step 2 Set the service type to group.

```
cd prepaid-accounting

[ //localhost/Radius/Services/prepaid-accounting ]
  Name = prepaid-accounting
  Description =
  Type =

set type group

Set Type group
```

The group service has the following properties:

```
[ //localhost/Radius/Services/prepaid-accounting ]
  Name = prepaid-accounting
  Description =
  Type = group
  IncomingScript~ =
  OutgoingScript~ =
  ResultRule = AND
  GroupServices/
```

Step 3 Reference the Prepaid and Prepaid-LocalAccounting services under GroupServices.

```
cd GroupServices

[ //localhost/Radius/Services/prepaid-accounting/GroupServices ]

add 1 prepaid

Added 1

add 2 prepaid-LocalFileAccounting

Added 2
```

Setting Up an Authentication Group Service

A prepaid billing solution usually requires a group service to tie together an AA service with a prepaid service, a group service to tie together an accounting service with a prepaid service, or both.

If you are using an AA service with your prepaid billing solution, you must configure a group service, for example **prepaid-users**, that ties the requests to the AA service with the prepaid service.

If you are using Cisco Prime AR for an accounting service with your prepaid billing solution, you must configure a group service, for example **prepaid-file**, that ties accounting requests to both the regular accounting service and the prepaid service.

Setting up an Authentication Group Service

To set up an authentication group service:

Step 1 Use **aregcmd** to add a prepaid authentication group service under **/Radius/Services**.

```
cd /radius/services
```

```
add prepaid-groupAuthentication
```

```
Added group-prepaidAuthentication
```

```
cd group-prepaidAuthentication
```

```
[ //localhost/Radius/Services/group-prepaidAuthentication ]
  Name = group-prepaidAuthentication
  Description =
  Type =
```

Step 2 Set the service type to group.

```
set type group
```

```
Set Type group
```

The group service requires the ResultRule to be set to AND, the default setting for a group service.

```
ls
```

```
[ //localhost/Radius/Services/group-prepaidAuthentication ]
  Name = group-prepaidAuthentication
  Description =
  Type = group
  IncomingScript~ =
  OutgoingScript~ =
  ResultRule = AND
  GroupServices/
```

Step 3 Change directory to GroupServices and add references to the prepaid service and the authentication service.

```
cd GroupServices
```

```
[ //localhost/Radius/Services/group-prepaidAuthentication/GroupServices ]
```

```
add 1 Prepaid-LocalAuthentication
```

```
Added 1
```

```
add 2 prepaid
```

```
Added 2
```

Configuring CRB Prepaid Billing for SSG

In addition to the configuration described in [CRB Prepaid Billing, page 16-7](#), when using CRB-Prepaid billing with SSG, you must also perform the following:

- [Setting Up an Outgoing Script](#)
- [Setting Up an Incoming Script](#)
- [Setting Up a Prepaid Outgoing Script](#)
- [Adding Prepaid Clients](#)

Setting Up an Outgoing Script

To set up an outgoing script:

Step 1 Use `aregcmd` to add the **PCO-Parse-Client-Outgoing** outgoing script under **/Radius/Scripts**:

```
cd /radius/scripts
```

```
add PCO-Parse-Client-Outgoing
```

```
Added PCO-Parse-Client-Outgoing
```

```
cd PCO-Parse-Client-Outgoing
```

```
[ //localhost/Radius/Scripts/PCO-Parse-Client-Outgoing ]
  Name = PCO-Parse-Client-Outgoing
  Description =
  Language =
```

Step 2 Set the language to tcl.

```
set language tcl
```

```
Set Language tcl
```

Step 3 Set the filename to **PCO-parse.client-outgoing.tcl**.

```
set filename PCO-parse.client-outgoing.tcl
```

```
Set Filename PCO-parse.client-outgoing.tcl
```

Step 4 Set the EntryPoint to PCO-parse-client-outgoing.

```
set EntryPoint PCO-parse-client-outgoing
```

```
Set EntryPoint PCO-parse-client-outgoing
```

Setting Up an Incoming Script

To set up an incoming script:

Step 1 Use **aregcmd** to add the **PPI-Parse-Prepaid-Incoming** script under **/Radius/Scripts**.

```
cd /radius/scripts
add PPI-Parse-Prepaid-Incoming
```

Step 2 Set the language to tcl.

```
cd PPI-Parse-Prepaid-Incoming
set language tcl

Set Language tcl
```

Step 3 Set the filename to **PPI-Parse-Prepaid-Incoming.tcl**.

```
set filename PPI-Parse-Prepaid-Incoming.tcl

Set Filename PPI-Parse-Prepaid-Incoming.tcl
```

Step 4 Set the EntryPoint to **PPO-Parse-Prepaid-Outgoing**.

```
set EntryPoint PPO-Parse-Prepaid-Outgoing

Set EntryPoint PPO-Parse-Prepaid-Outgoing
```

Setting Up a Prepaid Outgoing Script

To set up a prepaid outgoing script:

Step 1 Use **aregcmd** to add the **PPO-Parse-Prepaid-Outgoing** outgoing script under **/Radius/Scripts**:

```
cd /radius/scripts
```

Step 2 Add the **PPO-Parse-Prepaid-Outgoing** outgoing script under **/Radius/Scripts**.

```
cd /radius/scripts
add PPO-Parse-Prepaid-Outgoing

Added PPO-Parse-Prepaid-Outgoing
```

Step 3 Set the language to tcl.

```
cd PPO-Parse-Prepaid-Outgoing
set language tcl

Set Language tcl
```

Step 4 Set the filename to **PPO-Parse-Prepaid-Outgoing.tcl**.

```
set filename PPO-Parse-Prepaid-Outgoing.tcl
```

```
Set Filename PPO-Parse-Prepaid-Outgoing.tcl
```

Step 5 Set the EntryPoint to PPO-Parse-Prepaid-Outgoing.

```
set EntryPoint PPO-Parse-Prepaid-Outgoing
```

```
Set EntryPoint PPO-Parse-Prepaid-Outgoing
```

Adding Prepaid Clients

To add prepaid clients:

Step 1 Use **aregcmd** to add the prepaid clients under **/Radius/Clients**.

```
cd /radius/clients
```

```
add SSG
```

A RADIUS client has the following properties:

```
[ //localhost/Radius/Clients/ssg ]
Name = ssg
Description =
IPAddress =
SharedSecret =
Type = NAS
Vendor =
IncomingScript~ =
OutgoingScript~ =
EnableDynamicAuthorization = FALSE
NetMask =
```

Step 2 Set the IPAddress property to the client IP address.

```
set IPAddress aaa.bbb.ccc.ddd
```

```
Set IPAddress aaa.bbb.ccc.ddd
```

Step 3 Set the SharedSecret.

```
set sharedsecret cisco
```

```
Set SharedSecret cisco
```

Step 4 Set the OutgoingScript to **PCO-Parse-Client-Outgoing**.

```
set out PCO-Parse-Client-Outgoing
```

```
Set OutgoingScript PCO-Parse-Client-Outgoing
```

Generic Call Flow

This section describes the generic call flow for the Cisco Prime AR CRB prepaid billing. The call flow is controlled by the AAA client. The Cisco Prime AR server converts VSAs into calls to the billing server.

Note

For information about call flows and attributes for IS835C, see [IS835C Prepaid Billing, page 16-2](#).

The packet flows presented in [Figure 16-1](#) are specific to the Cisco Prime AR CRB prepaid billing only. The headlines in the packet flows are general and do represent all data transferred. The letters **c**, **s**, and **b** in [Figure 16-1](#) designate the packet's source of **client**, **server**, or **billing server**, respectively.

Figure 16-1 Generic Call Flow Diagram

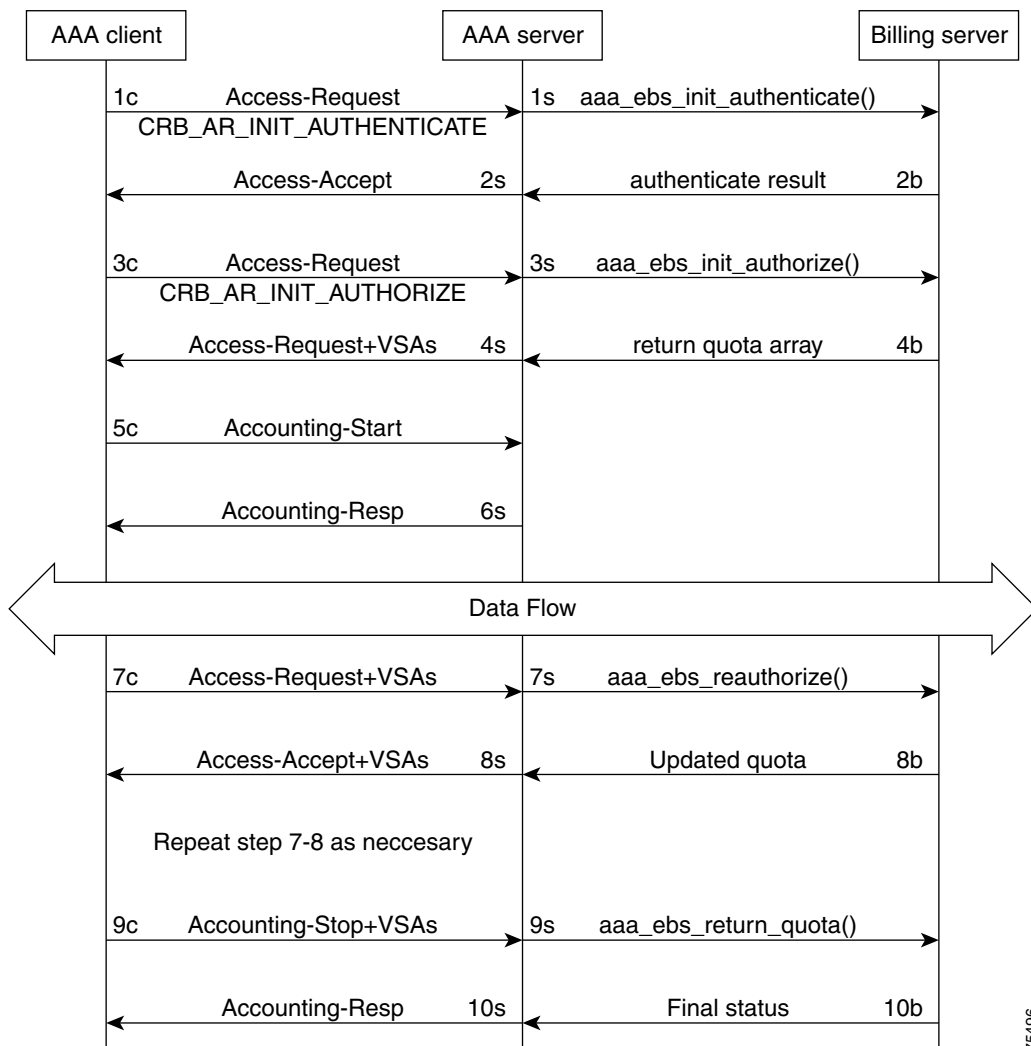

75496

This section contains the following topics:

- [Access-Request \(Authentication\)](#)
- [Access-Accept \(Authentication\)](#)
- [Access-Request \(Authorization\)](#)
- [Access-Accept \(Authorization\)](#)
- [Accounting-Start](#)
- [Data Flow](#)
- [Access-Request \(Quota Depleted\)](#)
- [Accept-Accept \(Quota Depleted\)](#)
- [Accounting Stop \(Session End\)](#)
- [Accounting Response \(Final Status\)](#)

Access-Request (Authentication)

Flow 1c shows the client sending the Access-Request to AAA Server, part of a normal authentication request. The exact nature of the message contents is dictated by the access technology, be it be CDMA1X-RTT, GPRS, or another. The Access-Request might involve other messages such as PAP/CHAP or another form of authentication.

The **Flow 1c** Access-Request might contain a prepaid specific VSA, CRB_AUTH_REASON. [Table 16-4](#) lists the attributes included in the authentication Access-Request. This tells the Cisco Prime AR server to authenticate the subscriber with the Prepaid server as well. If the value is CRB_AR_INIT_AUTHENTICATE, the initial quota must be obtained for a single service prepaid solution. If this VSA is not present, the Cisco Prime AR server will not authenticate with the Prepaid billing server.

Table 16-4 Attributes Sent During Subscriber Authentication

Attribute Number	Attribute Name	Description	Notes
1	User-Name	APPL: Mobile Node Username	Required
2	NAS IP Address	Accounting Node IP Address	APPL: Required, POA
31	Calling-station-ID	APPL:MSISDN or IMSI	APPL: Conditional
26, 9	CRB_AUTH_REASON CRB_AR_INIT_AUTHENTICATE	See VSA section	Required
26, 9	CRB_USER_ID	APPL:PDSN address or SSG address	APPL: Required, Address of the PDSN

Table 16-4 *Attributes Sent During Subscriber Authentication (continued)*

Attribute Number	Attribute Name	Description	Notes
26, 9	CRB_SERVICE_ID	APPL: Service ID such as Simple IP service, Mobile IP service, or VPN service	
26, 9	CRB_SESSION_ID	This VSA contains the session key ID information	Required; the session ID must be globally unique across all clients and across reboots of the client

In **Flow 1s**, the Cisco Prime AR server sends a call to the billing server to authenticate the prepaid user and possibly determine more information about the subscriber's account. The Cisco Prime AR server can be configured to generate this packet flow, using a subscriber profile parameter, if the request is from a prepaid subscriber.

Access-Accept (Authentication)

Flow 2b shows the billing server returning the authentication result. The billing server returns a failure if the prepaid subscriber has an inadequate balance.

Flow 2s shows the Cisco Prime AR server sending the Access-Accept to the AAA client. This message flow contains at least one prepaid billing-specific VSA (listed in [Table 16-5](#)) and might contain other access technology-specific attributes.

Table 16-5 *Attributes Sent to AAA client in Access-Accept (Authentication)*

Attribute Number	Attribute Name	Description	Notes
26, 9	CRB__USER_TYPE CRB_AR_INIT_AUTHENTICATE	See Vendor-Specific Attributes, page 16-25	Optional

Access-Request (Authorization)

In **Flow 3c**, the AAA client sends another Access-Request, this time to authorize the subscriber. [Table 16-6](#) lists the attributes required by the Cisco Prime AR server to authorize the subscriber. The session key ID used must be specified using a prepaid VSA pointing to the RADIUS attribute (standard or VSA).

Table 16-6 *Attributes Sent During Subscriber Authorization*

Attribute Number	Attribute Name	Description	Notes
1	User-Name	APPL: Mobile Node Username	Required
2	NAS IP Address	Accounting Node IP Address	APPL: Required, POA

Table 16-6 *Attributes Sent During Subscriber Authorization (continued)*

Attribute Number	Attribute Name	Description	Notes
31	Calling-station-ID	APPL:MSISDN or IMSI	APPL: Conditional
26, 9	CRB_AUTH_REASON CRB_AR_INIT_AUTHORIZE	See Vendor-Specific Attributes, page 16-25	Required
26, 9	CRB_USER_ID	APPL:PDSN address or SSG address	APPL: Required, Address of the PDSN
26, 9	CRB_SERVICE_ID	APPL: Service ID such as Simple IP service, Mobile IP service, or VPN service	
26, 9	CRB_SESSION_ID	This VSA contains the session key ID information	Required; the session ID must be globally unique across all clients and across reboots of the client

.In **Flow 3s**, the Cisco Prime AR server sends the Prepaid billing server to obtain a quota. The quota might contain several values depending on the number of measurement parameters chosen.

Access-Accept (Authorization)

Flow 4b shows the billing server returning the quota array for the subscriber.

In **Flow 4s**, the Cisco Prime AR server converts the quota array received into VSAs and sends an Access-Accept with the assembled VSAs to the AAA client. [Table 16-7](#) lists the prepaid-specific VSAs that might be included in the Access-Accept response message sent to the AAA client. For more detailed information about the VSAs, see [Vendor-Specific Attributes, page 16-25](#).

Table 16-7 *Attributes Sent to AAA client in Access-Accept (Authorization)*

Attribute Number	Attribute Name
26, 9	CRB_DURATION
26, 9	CRB_TOTAL_VOLUME
26, 9	CRB_UPLINK_VOLUME
26, 9	CRB_DOWNLINK_VOLUME
26, 9	CRB_TOTAL_PACKETS
26, 9	CRB_UPLINK_PACKETS
26, 9	CRB_DOWNLINK_PACKETS

Flows 3c through **4s** are repeated for every service started or restarted by the AAA client.

However, if the return parameters indicate that the authorization is rejected, an Access-Accept message is generated and sent to the client as shown in [Table 16-8](#). When this type of error condition occurs, no other VSA is included in the Access-Accept message.

Table 16-8 Attribute Sent to Report Error Condition to AAA client

Attribute Number	Attribute Name	Description	Notes
26, 9	CRB_TERMINATE_CAUSE	Identifies why a subscriber failed authentication: 1. Exceeded the balance 2. Exceeded the overdraft 3. Bad credit 4. Services suspended 5. Invalid User	Conditional; rejection might be returned with Access-Accept and zero (0) quota

Accounting-Start

In **Flow 5c**, the AAA client sends the Accounting-Start. In **Flow 6s**, the Cisco Prime AR server replies with the Accounting-Response.

Data Flow

At this point, the data transfer begins. The AAA client monitors the subscriber's allocated quotas for metering parameters. A subscriber's Reauthorization request is generated when a quota for at least one of the metering parameters, is depleted.

Access-Request (Quota Depleted)

Flow 7c shows the client sending an Access-Request to the Cisco Prime AR server because at least one quota has been depleted. The Access-Request includes different measurements of how much of the quotas were used in VSA format. This enables the billing server to account for the usage and manage the subscriber's balance before assigning a new quota. [Table 16-9](#) lists the attributes returned to the Cisco Prime AR server:

Table 16-9 Attributes Sent by NAS When Quota Depleted

Attribute Number	Attribute Name	Description	Notes
1	User-Name	APPL: Mobile Node Username	Conditional
2	NAS IP Address	Accounting Node IP Address	APPL: Required, POA address, or Home Node address
31	Calling-station-ID	APPL:MSISDN or IMSI	APPL: Conditional
26, 9	CRB_AUTH_REASON	See VSA	Required
26, 9	CRB_USER_ID	APPL: PDSN address or SSG address	APPL: Required, address of SGSN

Table 16-9 *Attributes Sent by NAS When Quota Depleted (continued)*

Attribute Number	Attribute Name	Description	Notes
26, 9	CRB_DURATION	See Vendor-Specific Attributes , page 16-25	Required
26, 9	CRB_TOTAL_VOLUME		Conditional
26, 9	CRB_UPLINK_VOLUME		
26, 9	CRB_DOWNLINK_VOLUME		
26, 9	CRB_TOTAL_PACKETS		
26, 9	CRB_UPLINK_PACKETS		
26, 9	CRB_DOWNLINK_PACKETS		

Accept-Accept (Quota Depleted)

Flow 7s shows the Cisco Prime AR server returning the used quota array to the billing server. The call includes `aaa_ebs_reauthoriz()`. The billing server sends an updated quota array for the next period to the Cisco Prime AR server.

In **Flow 8s**, the Cisco Prime AR server converts the quota array into VSAs and sends them to the AAA client.

Table 16-10 *Attributes Sent to AAA Client in Access-Accept (Reauthorization)*

Attribute Number	Attribute Name
26, 9	CRB_USER_TYPE
26, 9	CRB_DURATION
26, 9	CRB_TOTAL_VOLUME
26, 9	CRB_UPLINK_VOLUME
26, 9	CRB_DOWNLINK_VOLUME
26, 9	CRB_TOTAL_PACKETS
26, 9	CRB_UPLINK_PACKETS
26, 9	CRB_DOWNLINK_PACKETS

Accounting Stop (Session End)

In **Flow 9c**, the client sends an Accounting-Stop to the Cisco Prime AR server to end the session. The Accounting-Stop message includes an updated quota array with the usage adjustments since the previous authorization in the VSA form.

[Table 16-11](#) lists the attributes included in the Accounting-Stop message set to the Cisco Prime AR server and forwarded to the billing server.

Accounting Response (Final Status)

In **Flow 9s**, the Cisco Prime AR server sends the used quota array to the billing server in an Accounting-Stop message. Any values returned by the billing server in **Flow 10b** are discarded.

Flow 10s shows the Cisco Prime AR server sending final Accounting-Response message to the AAA client.

Table 16-11 *Attributes Sent in Accounting-Stop Message*

Attribute Number	Attribute Name	Description	Notes
1	User-Name	APPL: Mobile Node Username	Conditional
2	NAS IP Address	Accounting Node IP Address	APPL: Required, POA
31	Calling-station-ID	APPL:MSISDN or IMSI	APPL: Conditional
40, 2	Acct_status_type	Indicates the accounting “Stop” for the service	Required; this value (2) indicates an Accounting-Stop request message
42	Acct-Input-Octets	The number of octets sent by the subscriber; uplink	Required
43	Acc_Output_Octets	The number of octets received by the subscriber; downlink	
46	Acct-Session-Time	Duration of the session	
47	Acct-Input-Packets	Number of packets sent by the subscriber	
48	Acct-Output-Packets	Number of packets received by the subscriber	
49	Acct-Terminate-Cause	This parameter, used for tracking, should remain the same for all accounting requests for a given service.	
26, 9	CRB_DURATION	See Vendor-Specific Attributes, page 16-25	Conditional
26, 9	CRB_TOTAL_VOLU ME		
26, 9	CRB_UPLINK_VOLU ME		
26, 9	CRB_DOWNLINK_V OLUME		
26, 9	CRB_TOTAL_PACKE TS		
26, 9	CRB_UPLINK_PACK ETS		
26, 9	CRB_DOWNLINK_PA CKETS		
26, 9	CRB_SESSION_ID	Specifies the RADIUS attribute carrying the session ID information	Optional

Vendor-Specific Attributes

Vendor-specific attributes are included in specific RADIUS packets to communicate prepaid user balance information from the Cisco Prime AR server to the AAA client, and actual usage, either interim or total, between the NAS and the Cisco Prime AR Server.

Table 16-12 lists the VSAs that will be defined in the API. Table 16-12 also lists the string to be used with Cisco-AVPair below the VSA.

Note

VSAs that start with CRB are used for Cisco Radius Billing prepaid service.

Table 16-12 Vendor-Specific Attributes for the Cisco Prepaid Billing Solution

VSA Name	Type	Source (Call Flow)	Description
CRB_AUTH_REASON crb-auth-reason	Int8	1c, 7c, 7'c	Passed with re-authorization: 1. Initial Authentication 2. Initial Authorization 3. Re-authorization 4. Return Quota 5. Query to EBS
CRB_USER_ID crb-user-id	String	1c, 7c, 7'c	APPL: In PDSN this can be Address of the PDSN.
CRB_SERVICE_ID crb-service-id	String	1c, 7c	Identifies the subscriber's service
CRB_USER_TYPE crb-entity-type	Int8	4s	Type of user: 1. Prepaid user 2. Post-paid with no credit limit 3. Post-paid with credit limit 4. Invalid user The source for this VSA value could be from the Subscriber profile or from the billing server

Table 16-12 Vendor-Specific Attributes for the Cisco Prepaid Billing Solution (continued)

VSA Name	Type	Source (Call Flow)	Description
CRB_DURATION crb-duration	Int32	4s, 8s	Downlink quota received by the AAA client
CRB_TOTAL_VOLUME crb-total-volume			Total Volume quota received by the AAA client
CRB_UPLINK_VOLUME crb-uplink-volume			Uplink volume quota received by the AAA client
CRB_DOWNLINK_VOLUME crb-downlink-volume			Uplink Volume quota received by the AAA client
CRB_TOTAL_PACKETS crb-total-packets			Downlink Packet quota received by the AAA client
CRB_UPLINK_PACKETS crb-uplink-packets			Uplink Packet quota received by the AAA client
CRB_DOWNLINK_PACKETS crb-downlink-packets			Uplink Volume quota received by the AAA client
CRB_SESSION_ID crb-session-id			String

Table 16-12 Vendor-Specific Attributes for the Cisco Prepaid Billing Solution (continued)

VSA Name	Type	Source (Call Flow)	Description
CRB_TERMINATE_CAUSE crb-terminate-cause	Int8	4se	Identifies why a subscriber failed authentication: <ol style="list-style-type: none"> 1. Exceeded the balance 2. Exceeded the overdraft 3. Bad credit 4. Services suspended 5. Invalid User 6. Invalid Password 7. System Error 8. Disabled 9. Expired 10. Valid in Future 11. Used up 12. No Parallel sessions 13. Session Already closed 14. Invalid session
CRB_PRIVATE crb-private	String	n/a	Reserved for future use

Implementing the Prepaid Billing API

A shared library must implement the API functions to perform the various tasks given in the description of each of the function. This needs to be compiled as a shared library and then specified as part of the remote server configuration at the Filename property. See [Setting Up a Prepaid Billing RemoteServer, page 16-3](#) or [Setting Up a Prepaid Billing RemoteServer, page 16-8](#).

At startup, Cisco Prime AR loads the library dynamically and registers the API functions, then calls out the library initialization API once at startup. The call to initialize functions initializes various data structures and connections with the billing server, as required.



Note

Cisco works with you to develop the prepaid billing service and implement the API. For more information, contact your Cisco systems engineer.

At various times, according to the call flow described in the Prepaid Call Flow Specification (CRB or IS835C), Cisco Prime AR calls out appropriate API functions present in the shared library. The values for the arguments passed to these API calls are purely derived from the incoming RADIUS packet and Cisco Prime AR does not maintain any dynamic information related to the call flow. It is up to the API function to make use of the information passed to it as C structures to contact the Billing server, get appropriate data, and return the same to Cisco Prime AR using the designated arguments.



Note

See the API specifications for more details pertaining to the arguments and return values of the API.



CHAPTER 17

Using Cisco Prime Access Registrar Server Features

This chapter provides information about how to use the following Cisco Prime Access Registrar (Cisco Prime AR) server features.

This chapter contains the following sections:

- [Incoming Traffic Throttling](#)
- [Backing Store Parsing Tool](#)
- [Configurable Worker Threads Enhancement](#)
- [Session-Key Lookup](#)
- [Query-Notify](#)
- [Support for Windows Provisioning Service](#)
- [Command Completion](#)
- [Service Grouping Feature](#)
- [SHA-1 Support for LDAP-Based Authentication](#)
- [Dynamic Attributes](#)
- [Tunneling Support Feature](#)
- [xDSL VPI/VCI Support for Cisco 6400](#)
- [Apply Profile in Cisco Prime Access Registrar Database to Directory Users](#)
- [Directory Multi-Value Attributes Support](#)
- [MultiLink-PPP \(ML-PPP\)](#)
- [Dynamic Updates Feature](#)
- [NAS Monitor](#)
- [Automatic Information Collection \(arbug\)](#)
- [Simultaneous Terminals for Remote Demonstration](#)
- [Support for RADIUS Check Item Attributes](#)
- [User-Specific Attributes](#)
- [Packet of Disconnect](#)
- [Dynamic DNS](#)

- [Dynamic Service Authorization Feature](#)
- [Remote Session Management](#)
- [Wx Interface Support for SubscriberDB Lookup](#)
- [Smart Grid Solution Management](#)
- [TACACS+ Support for AA](#)

Incoming Traffic Throttling

Cisco Prime AR offers two options to tackle traffic bursts by limiting incoming traffic. You will find two properties, `MaximumIncomingRequestRate` and `MaximumOutstandingRequests`, under **/Radius/Advanced** to limit the incoming traffic.

This contains the following sections:

- [MaximumIncomingRequestRate](#)
- [MaximumOutstandingRequests](#)

MaximumIncomingRequestRate

You can use the `MaximumIncomingRequestRate` property to limit incoming traffic in terms of “allowed requests per second”.

For example, if you set the `MaximumIncomingRequestRate` to n , then at any given second, only n requests are accepted for processing. In the next second, another n requests are accepted regardless of whether the requests accepted earlier are processed or not. This condition serves as a soft limit.

The `MaximumIncomingRequestRate` property by default is zero (disabled).

MaximumOutstandingRequests

You can use the `MaximumOutstandingRequests` property to limit incoming traffic in terms of “requests processed”.

For example, if you set the `MaximumOutstandingRequests` to n , n requests are accepted for processing. Further requests are accepted only after processing some of these requests and sending the replies back. This condition serves as a hard limit.

The `MaximumOutstandingRequests` property by default is zero (disabled).



Note

You can enable either of these properties independent of the other.

Configuring the MaximumOutstandingRequests

To configure the `MaximumIncomingRequestRate` or `MaximumOutstandingRequests` property:

-
- Step 1** Log in to `aregcmd`.
 - Step 2** Change directory to **/Radius/Advanced**.
 - Step 3** Set the `MaximumIncomingRequestRate` or `MaximumOutstandingRequests` property to non-zero values.

```
set MaximumIncomingRequestRate n
```

or

```
set MaximumOutstandingRequests n
```

where n is any nonzero value.

Step 4 Save the configuration; enter:

```
save
```

Step 5 Reload the server; enter:

```
reload
```

Backing Store Parsing Tool

Cisco Prime AR tool, **carbs.pl**, helps to analyze the session backing store files. You will find this tool under **/cisco-ar/bin** directory.

Using **carbs.pl**, you can:

- Get information about the active, stopped, and stale Radius sessions.
- Clear phantom sessions manually.
- Process the binary log files and get information in a user-readable format.

The syntax is:

```
carbs.pl [-a] [-d <dir>] [-f <logfile>] [-v] [p] [-o <output>] [-h]
```

-a—All session statistics (active, stale, stopped)

-d—<Directory> Default: .

-f—<Filename> Default: 00*.log

-v—verbose Default: off

-p—Clear phantom sessions

-o—<Filename> Output log to TEXT

-h—Help, usage

[Table 17-1](#) lists the options available with **carbs.pl** and their description.

Table 17-1 Carbs.pl Options and Description

Option	Description
-d<directory>	Optional. Accepts a directory as parameter with no trailing slash. You can use this option to change the default directory to scan for BackingStore log files. Default is current directory.
-f<logfile>	Optional. Accepts a logfile as parameter with no leading or trailing slashes. You can use this option to change the default log files. Allows you to enter individual logfile name as well as wildcard characters surrounded by single quotes.
-v	Optional. No parameters. You can use this option to get total session count and phantom session count.
-p	Optional. No parameters. Generates a list of phantom sessions. You can use this option to clear the stale sessions.
-o	Optional. Accepts <output file> as parameter. You can use this option to convert BackingStore log files to readable files and write the results to the output file specified.
-a	Optional. No parameters. You can use this option to print all session statistics, such as per-NAS stale session count, total active sessions, and total stale sessions.
-h	You can use this option to get help with usage of carbs.pl.

Configurable Worker Threads Enhancement

Cisco Prime AR provides a configurable variable you can use to increase the number of worker threads to handle a greater number of RADIUS packets during peak operating periods. This variable controls the processing of greater number of RADIUS packets than expected during peak operating periods.

The variable, RADIUS_WORKER_THREAD_COUNT, is found in the **arserver** file under **/cisco-ar/bin/arserver** and controls the number of worker threads the Cisco Prime AR server creates. You can increase the number of worker threads to help make more efficient use of the server's CPU.



Note

Before you increase the setting for RADIUS_WORKER_THREAD_COUNT, you should be certain that you are running into a worker thread starvation issue. If you use scripts that consume a lot of processing and memory, you might run out of memory if you create too many worker threads.

Increasing the number of worker threads also increases memory utilization.

The default value of RADIUS_WORKER_THREAD_COUNT for servers running a Solaris operating system is 256. The default value for servers running Red Hat Enterprise Linux 5.3/5.4/5.5/6.0/6.1/6.2 32-bit /64-bit operating system (with 32-bit library is only for 64-bit operating system).

The purpose of this enhancement is to take advantage of spare CPU bandwidth which was not being used in earlier releases of Cisco Prime AR due to a lower number of worker threads. At times, the worker threads would be stuck doing work that took a long time to complete, like running a script. Having more threads will help mitigate these situations and will help improve on the latency created due to lack of free worker threads.

**Note**

Before modifying the RADIUS_WORKER_THREAD_COUNT variable, consult with a TAC representative to ensure that modifying the RADIUS_WORKER_THREAD_COUNT is warranted.

Modifying the RADIUS WORKER THREAD COUNT

To modify the RADIUS_WORKER_THREAD_COUNT variable:

Step 1 Log into the Cisco Prime AR server as a root user and change directory to **/cisco-ar/bin**.

Step 2 Use a text editor and open the **arserver** file.

Step 3 Locate the line with the RADIUS_WORKER_THREAD_COUNT variable.

```
#change this to configure number of worker threads
RADIUS_WORKER_THREAD_COUNT=256
```

Step 4 Modify the number of RADIUS worker threads to the number you choose.

**Note**

There is no upper limit to the number of RADIUS worker threads you can enable in your Cisco Prime AR server, but you should take care not to exceed your server's memory capacity.

Step 5 Save the file and restart the Cisco Prime AR server.

Session-Key Lookup

The Session-Key Lookup feature enables you to identify the Session Manager and Session Key of an existing session based on certain attributes associated with that session, such as the Mobile Station Integrated Services Digital Network (MSISDN) number.

The Session-Key Lookup feature requires the following enhancements to Cisco Prime AR software:

- Enabling a query service to be invoked for Ascend-IP-Allocate packets
- Enabling the setting of the Session-Key and Session-Manager environment variables by a query operation
- Performing session management after the query operation
- A new environment variable, Set-Session-Mgr-And-Key-Upon-Lookup, which when set to TRUE causes a session-cache Resource Manager to set the Session-Manager and Session-Key environment variables during the query lookup.

The Session-Key Lookup feature is useful in a scenario where an existing session requires an update from an incoming Ascend-IPA-Allocate packet (from a different NAS or device) with modified authorization attributes. Note that this Ascend-IPA-Packet might not have the exact set of attributes as the original packet that created the session. However, the Ascend-IPA-Allocate packet must contain at least one attribute that can uniquely identify the session (such as the MSISDN number) and should contain the same UserName of the original session.

The Session-Key Lookup feature works in tandem with the Radius Query feature, where a Radius Query service is defined with the unique attribute (such as the MSISDN number) as the query-key and is configured to query all session managers. The Query-Service environment variable is set to the defined Radius Query service and the new environment variable (Set-Session-Mgr-And-Key-Upon-Lookup) is set to TRUE for this Ascend-IPA-Allocate packet. This triggers a query operation on all the live sessions. If there is a match, the Session-Manager and Session-Key of that session is used for subsequent session management. During session management, the session cache is updated with the modified authorization attributes.

The Session-Manager OutgoingScript (or any outgoing script that executes after the Session-Manager Outgoing Script) should not reject the packet when doing a Session-Key lookup. Doing so causes the session to be deleted.

Query-Notify

The Query-Notify feature enables you to store information about Wireless Application Protocol (WAP) gateways that have queried for User Identity-IP Address mapping and send appropriate messages to the WAP gateway when the subscriber logs out of the network.

Cisco Prime AR has been enhanced to update the session cache with the attribute-value pairs of an interim accounting update packet. This ensures the Cisco Prime AR server provides updated or current information to the WAP gateway during the proxy of interim records or query of the session cache.

Cisco Prime AR has been enhanced to also notify the WAP gateways that have queried a session with interim accounting update packets. If a WAP gateway does not respond to the Interim accounting update packets, the Cisco Prime AR server times out and retries by notifying the WAP gateways again. If there is no response after all the retries, the proxy packet is deleted and no change is made to the session or the WAP gateway's state in the Cisco Prime AR server. You can configure the number of retries under **/Radius/Clients/notificationproperties**.

The accounting response packet from the Cisco Prime AR server to the GPRS Gateway Support Node (GGSN) is independent of the proxy operation to the WAP gateways. The accounting response packet is sent back immediately without waiting for responses from the WAP gateways.

The Query-Notify feature also enables you to quarantine IP addresses for a configurable amount of time if a WAP gateway does not respond to Accounting-Stop packets sent by the Cisco Prime AR server.

The Cisco Prime AR server stores information about clients (usually the IP address) that queried for particular user information and sends RADIUS Accounting-Stop packets to those clients when the Cisco Prime AR server receives the Accounting-Stop packet. There is no intermediate proxy server between the Cisco Prime AR server and the WAP gateway.

To support the Query-Notify feature, the Cisco Prime AR server's *radius-query* service has been modified to also store information like the IP address about the clients queried for cached information. The information is stored in the user session record along with the cached information so it is available after a server reload.

Configuring the Query-Notify feature

To configuring the Query-Notify feature:

-
- Step 1** Configure the Clients object under **/Radius/Clients**.
- Step 2** Set the EnableNotifications property to TRUE.
- The EnableNotifications property indicates that a client can receive Accounting-Stop notifications from the Cisco Prime AR server. When EnableNotifications is set to TRUE, a sub-directory named NotificationProperties appears in client object configuration.
- Step 3** Configure the properties under the client's NotificationProperties subdirectory.
- See [Clients, page 4-6](#), for information about how to configure these properties.
- Step 4** Configure a list of attributes to store under **/Radius/Advanced/Attribute Groups/<Notification Group>** where *<notification group>* is the name of an Attribute Group containing a list of attributes to be stored.
-

This section contains the following topics:

- [Call Flow](#)
- [Configuration Examples](#)
- [Memory and Performance Impact](#)

Call Flow

This section describes the call flow of the Query-Notify feature.

1. The Cisco Prime AR server caches information from an from Accounting-Start.
This information is usually from a GGSN when a subscriber enters into the network.
2. When a WAP gateway receives a request to authenticate a subscriber, it queries the Cisco Prime AR server using an Access-Request packet to retrieve the cached information for that subscriber.
3. The Cisco Prime AR server responds with Access-Accept if an entry is found for the subscriber in its cache; otherwise the server returns an Access-Reject.

The Cisco Prime AR server sends an Access-Accept packet to the WAP gateway. The list of attributes sent in this Access-Accept will depends on radius-query service configuration.



Note You use **aregcmd** to configure the attributes for the Access-Accept packet in the AttributesToBeReturned subdirectory under a radius-query service type.

4. If the Cisco Prime AR server finds a cache entry for the subscriber and if the EnableNotifications property is set to TRUE, the Cisco Prime AR server stores the client IP address in the subscriber's cache.
5. If the Cisco Prime AR server receives an Accounting-Interim-Update packet from the GGSN, it responds by sending an Accounting-Response packet then sends the Accounting-Interim-Update packets to all the queried clients of the WAP Gateways.

If the WAP gateway queried clients do not respond to the Accounting-Interim-Update packets, the Cisco Prime AR server times out and retries by notifying the WAP gateways again. If there is no response after all the retries, the proxy packet is deleted and no change is made to the session or the WAP gateway's state in the Cisco Prime AR server. The `StaleSessionTimeout` property under **/Radius/Advanced** is not applicable for Accounting-Interim-Update packets.

6. When the subscriber logs out of the network, the Cisco Prime AR server receives an Accounting-Stop packet and responds by sending an Accounting-Response back to the client.

Before releasing the subscriber's session, the Cisco Prime AR server looks for any client IP addresses in the subscriber's cache. If it finds any, the Cisco Prime AR server sends Accounting-Stop packets to those clients with the attributes configured in the `NotificationAttributeGroup` subdirectory for each client.

The Cisco Prime AR server forms the attributes with those attributes in the session cache and from the Accounting-Stop packet. The Cisco Prime AR server uses the value configured for the `Port` property in the `NotificationProperties` subdirectory as the destination port for the Accounting-Stop packet and uses the client's shared secret.

The Cisco Prime AR server then waits for Accounting-Response packets from each client to which it has sent Accounting-Stop packets. The Cisco Prime AR server waits for the time interval configured in the `InitialTimeout` property configured in the `NotificationProperties` subdirectory before sending another Accounting-Stop packet. If it does not receive an Accounting-Response packet, the Cisco Prime AR server sends additional Accounting-Stop packets until the number of attempts reaches the value configured in the `MaxTries` property in the `NotificationProperties` subdirectory.

7. When the Cisco Prime AR server receives an Accounting-Response packet from each client, the server releases the subscriber session.

If the Cisco Prime AR server does not receive Accounting-Response packets from all clients after the configured time and attempts, the server maintains the subscriber session for the time interval configured in the `StaleSessionTimeout` property in **/Radius/Advanced** then releases the subscriber session.

The Cisco Prime AR server maintains the subscriber session to address the quarantine IP address requirement. The Cisco Prime AR server must quarantine IP addresses if a WAP gateway does not respond to Accounting-Stop sent by the Cisco Prime AR server. The length of time an IP address is quarantined depends on the value of the `InitialTimeOut` property under the **NotificationProperties** subdirectory of **/Radius/Clients/wap_gateway**.

8. If the `StaleSessionTimeout` property is TRUE for a subscriber session, the Cisco Prime AR server rejects any query requests from clients for this session cache. After the `StaleSessionTimeout` expires, the Cisco Prime AR server will again send Accounting-Stop to all the clients listed in the session and proceeds to delete this subscriber session regardless of the status of the Accounting-Stop.

Configuration Examples



Note

In addition to the following configuration, the `StaleSessionTimeout` property must be set in **/Radius/Advanced**. This property has a default value of 1 hour.

The following shows an example configuration for a Query-Notify client:

```
[ //localhost/Radius/Clients/wap-gateway1 ]
  Name = wap-gateway1
  Description =
  IPAddress = 10.100.10.1
  SharedSecret = secret
  Type = NAS
  Vendor =
  IncomingScript~ =
  OutgoingScript~ =
  EnableDynamicAuthorization = FALSE
  NetMask =
  EnableNotifications = TRUE
  NotificationProperties/
    Port = 1813
    InitialTimeout = 5000
    MaxTries = 3
    NotificationAttributeGroup = notifyGroup
```

The following shows an example configuration for a Query-Notify AttributeGroup:

```
[ //localhost/Radius/Advanced/AttributeGroups/notifyGroup ]
  Name = notifyGroup
  Description =
  Attributes/
    1. User-Name
    2. Acct-Session-Id
    3. NAS-Identifier
    4. NAS-Port
```

Memory and Performance Impact

Using the Query-Notify feature will have the following effects:

- There will be a memory impact because the Cisco Prime AR server caches IP addresses of clients queried in the session record.
- There will be an impact on performance because the Cisco Prime AR server has to persist the cached IP address information before responding to **radius-query** requests.

Support for Windows Provisioning Service

Cisco Prime AR supports Microsoft's Windows Provisioning Service (WPS). WPS provides hotspot users with seamless service to public WLAN hotspots by using Microsoft Windows-based clients. The Microsoft WPS solution requires Microsoft-based software in the data center for the RADIUS server and the provisioning server.

This section contains the following topics:

- [Call Flow](#)
- [Example Configuration](#)
- [Unsupported Features](#)

Call Flow

The following is the WPS process and Wireless Internet Service Provider (WISP) packet sequence for a new wireless client login at a Wi-Fi hotspot location:

1. The client discovers the WISP network at a Wi-Fi hotspot.
2. The client authenticates as guest (with null username and credentials) to the Cisco Prime AR server.
3. The client is provisioned and a new account is created.
4. The client is authenticated using the new account credentials and accesses the Internet.

The Cisco Prime AR server performs the following functions during WPS:

1. Detects the guest subscriber login from the null username and null credentials during PEAPv0 (MS-PEAP) authentication.
2. Grants a successful login and returns a *sign-up* URL of the provisioning server as a PEAP-Type-Length-Value (TLV) in the next Access-Challenge Packet.

The following is an example value for the URL PEAP-TLV:

```
http://www.example.com/provisioning/master.xml#sign up
```

Where *#sign up* is the parameter for this action and is a required element of the value.

The sign-up URL value is passed when the user authenticates as guest. The sign-up URL is a fragment within the Master URL. You can also configure other fragments to be returned in the Master URL. See [Master URL Fragments, page 17-11](#) for more information about the different fragments.

3. Sends a VLAN-ID or IP filter (or both) in the final Access-Accept packet to restrict the guest user's accessibility to only the Provisioning server.
4. Authenticates using the user configuration in the user database after the client is provisioned and a new account is created.

Example Configuration

The following shows an example configuration for the WPS feature:

```
[ //localhost/Radius/Services/peapv0 ]
  Name = peapv0
  Description =
  Type = peap-v0
  IncomingScript~ =
  OutgoingScript~ =
  MaximumMessageSize = 1024
  PrivateKeyPassword = <password>
  ServerCertificateFile = <path_to_ServerCertificateFile>
  ServerRSAKeyFile = <path_to_ServerRSAKeyFile>
  CACertificateFile = <path_to_CACertificateFile>
  CACertificatePath = <path_to_CACertificatePath>
  ClientVerificationMode = Optional
  VerificationDepth = 4
  EnableSessionCache = True
  SessionTimeout = "5 Minutes"
  AuthenticationTimeout = 120
  TunnelService = eap-mschapv2
  EnableWPS = True
  MasterURL = http://www.example.com/provisioning/master.xml
  WPSGuestUserProfile = WPS-Guest-User-Profile
```

When you set the EnableWPS property to TRUE, you must provide values for the properties MasterURL and WPSGuestUserProfile. See [Environment Variables](#), page 17-11 for more information.

Environment Variables

The following two environment variables are used to support WPS:

- [Send-PEAP-URI-TLV](#)
- [Master-URL-Fragment](#)

Send-PEAP-URI-TLV

Send-PEAP-URI-TLV property is a Boolean value used by the authenticating user service to make the PEAP-V0 service include the URI PEAP-TLV in the protected success message. Under different circumstances Cisco Prime AR might send back different fragments within the MasterURL to the client, as described above.

The conditions under which this has to be sent is best known to the user authentication service (the service that is specified within the eap-mschapv2 service, which in turn is the tunnel service for PEAP-V0 service). So when it decides that it needs to send back the URL it can set this variable to TRUE. The default value for this is FALSE.

Master-URL-Fragment

The Cisco Prime AR authenticating user service uses Master-URL-Fragment to set the fragment within the Master URL that needs to be sent back. The Cisco Prime AR user authentication service sets the fragment to different values under different circumstances. While the Send-PEAP-URL-TLV indicates whether to send the URL or not, Master-URL-Fragment is used to intimate which fragment within the URL needs to be sent. If this variable is not set and if it is required to send the URL, '#signup' will be sent by default.

Master URL Fragments

The following sections describe the different fragments the RADIUS server might send to the AP in the Master URL:

- [Sign up](#)
- [Renewal](#)
- [Password change](#)
- [Force update](#)

Sign up

This value is passed when the user authenticates as guest. The following is an example value for the URL PEAP-TLV:

```
http://www.example.com/provisioning/master.xml#sign up
```

where #sign up is the parameter for this action and a required element of the value.

Renewal

This value is passed when the user's account is expired and needs renewal before network access can be granted. The following is an example value for the URL PEAP-TLV:

```
http://www.example.com/provisioning/master.xml#renewal
```

where #renewal is the parameter for this action and a required element of the value.

Password change

This value is passed when the user is required to change the account password. An example value for the URL PEAP-TLV is:

```
http://www.example.com/provisioning/master.xml#passwordchange
```

where #passwordchange is the parameter for this action and a required element of the value.

Force update

This value is passed when the WISP requires the Wireless Provisioning Services on the client to download an updated XML master file. This method of updating the XML master file on the client should be used only to correct errors; otherwise, the TTL expiry time in the XML master file is used to provide background updates. The following is an example value for the URL PEAP-TLV:

```
http://www.example.com/provisioning/master.xml#forceupdate
```

where #forceupdate is the parameter for this action and a required element of the value.

Unsupported Features

The following features are part of the Microsoft WPS functionality, but are not supported in the Cisco Prime AR:

- [Account Expiration and Renewal](#)
- [Password Changing and Force Update](#)

Account Expiration and Renewal

When the user creates an account and logs in with that account, the RADIUS server authenticates and authorizes the request and sends back an Access-Accept with a Session-Timeout attribute. The Access Point (AP) then forces the wireless client to reauthenticate for every timeout value. When there is one timeout duration left in the user account, the RADIUS server needs to send back a *renewal* URL (a URL fragment within the master URL) to the client for the user to renew the account.

Cisco Prime AR does not support this feature because the interface the Cisco Prime AR server has with the AD (of the CiscoSecure Remote Agent) does not have provisions to get the expiration information of user account. However, this release does provide an environment variable to copy the URL fragment and to control whether or not to send the URL using another environment variable. This can be used to send the renewal URL. There are some limitations, however.

Password Changing and Force Update

The Password Changing option is passed when the user is required to change the account password. Force Update option is passed when the WISP requires the Wireless Provisioning Services on the client to download an updated XML master file.

These functions are not possible in this release for the same reason mentioned above, the loose coupling between Cisco Prime AR and the AD. Additionally, there is no known use case for this. As mentioned above, you can use the newly added environment variables to trigger these options.

Command Completion

Cisco Prime AR's command completion feature provides online help by listing possible entries to the current command line when you press the Tab key after entering a partial command. The Cisco Prime AR server responds based on:

- The location of the cursor including the current directory
- Any data you have entered on the command line prior to pressing the Tab key

The command completion feature emulates the behavior of Cisco IOS and Kermit. When you press the Tab key after entering part of a command, the Cisco Prime AR server provides any identifiable object and property names. For example, after you first issue **aregcmd** and log into Cisco Prime AR, enter the following:

```
cd <Tab>
```

```
Administrators/ Radius/
```

Pressing the Tab key consecutively displays possible context-sensitive choices.

In the following example, after changing directory to **/Radius/services/local-file** an administrator wants to see the possible types of authentication services that can set.

```
cd /Radius/services/local-file
```

```
//localhost/Radius/Services/local-file ]
Name = local-file
Description =
Type = file
IncomingScript~ =
OutgoingScript~ =
OutagePolicy~ = RejectAll
OutageScript~ =
FilenamePrefix = accounting
MaxFileSize = "10 Megabytes"
MaxFileAge = "1 Day"
RolloverSchedule =
```

```
set type <Tab>
```

```
eap-leap      file      local      radius-session
eap-md5      group    odbc       rex
eap-sim      ldap     radius     tacacs-udp
```

Values can also be tab-completed. For example, if you decide to set the local-file service's type to file, you can do the following:

```
set type f<Tab>
```

and the command line completes to:

```
set type file
```

Service Grouping Feature

The Service Grouping feature enables you to specify multiple services (called *subservices*) to be used with authentication, authorization, or accounting requests. The general purpose is to enable multiple Remote Servers to process requests.

Perhaps the most common use of this feature will be to send accounting requests to multiple Remote Servers thus creating multiple accounting logs. Another common use might be to authenticate from more than one Remote Server where, perhaps the first attempt is rejected, other Remote Servers can be attempted and an Access-Accept obtained.

Clearly, in the accounting request example, each request must be successfully processed by each subservice in order for the originator of the accounting request to receive a response. This is known as a *logical AND* of each of the subservice results. In the authenticate example, the first subservice which responds with an accept is returned to the client or if all subservices respond with *reject*, then a reject is returned to the client. This is known as a *logical OR* of each of the subservice results.

A Service is specified as a Group Service by setting its type to *group*, specifying the ResultRule (AND or OR) and specifying one or more subservices in the GroupServices subdirectory. The subservices are called in numbered order and as such are in an indexed list similar to Remote Server specification in a radius Service. Incoming and outgoing scripts for the Group Service can be optionally specified.

A subservice is any configured non-Group Service. When a Group Service is used, each subservice is called in exactly the same manner as when used alone (such as if specified as the DefaultAuthenticationService). Incoming and Outgoing scripts are executed if configured and Outage Policies are honored.

This section contains the following topics:

- [Configuration Example - AccountingGroupService](#)
- [Configuration Example 2 - AuthenticationGroupService](#)

Configuration Example - AccountingGroupService

To configure an accounting Group Service to deliver accounting requests to multiple Remote Servers:

Step 1 The first task is to set up the subservices which are to be part of the AccountingGroupService. Since subservices are merely configured Services which have been included in a service group, you need only define two new Services.

For this example, we will define two new radius Services called *OurAccountingService* and *TheirAccountingService*. A provider might want to maintain duplicate accounting logs in parallel with their bulk customer's accounting logs.

Step 2 Change directory to **/radius/services**. At the command line, enter the following:

cd /radius/services

```
[ //localhost/Radius/Services ]
Entries 1 to 2 from 2 total entries
Current filter: <all>
local-file/
local-users/
```

Step 3 At the command line, enter the following:

```
add OurAccountingService
```

```
add TheirAccountingService
```

The configuration of these Services is very similar to standalone Radius accounting service. Step-by-step configuration instructions are not provided, but the complete configuration is shown below:

```
[ //localhost/Radius/Services/OurAccountingService ]
Name = OurAccountingService
Description =
Type = radius
IncomingScript = OurAccountingInScript
OutgoingScript = OurAccountingOutScript
OutagePolicy = RejectAll
OutageScript =
MultipleServersPolicy = Failover
RemoteServers/
    1. OurPrimaryServer
    2. OurSecondaryServer

[ //localhost/Radius/Services/TheirAccountingService ]
Name = TheirAccountingService
Description =
Type = radius
IncomingScript = TheirAccountingInScript
OutgoingScript = TheirAccountingOutScript
OutagePolicy = RejectAll
OutageScript =
MultipleServersPolicy = Failover
RemoteServers/
    1. TheirPrimaryServer
    2. TheirSecondaryServer
```

The next step is to create the new **AccountingGroupService**. The purpose of this Service is to process Accounting requests through both OurAccountingService and TheirAccountingService.

Step 4 At the command line, enter the following:

```
add AccountingGroupService
```

```
Added AccountingGroupService
```

```
cd AccountingGroupService
```

```
[ //localhost/Radius/Services/AccountingGroupService ]
Name = AccountingGroupService
Description =
Type =
IncomingScript =
OutgoingScript =
```

set type group

```
Set Type group
```

Step 5 Set the ResultRule to *AND* to ensure that both services process the accounting request successfully.

set ResultRule AND

```
Set ResultRule AND
```

Is

```
[ //localhost/Radius/Services/AccountingGroupService ]
Name = AccountingGroupService
Description =
Type = group
IncomingScript =
OutgoingScript =
ResultRule = AND
GroupServices/
```

set IncomingScript AcctGroupSvcInScript**set OutgoingScript AcctGroupSvcOutScript**

Add OurAccountingService and TheirAccountingService as subservices of the Group Service.

Step 6 At the command line, enter the following:

cd GroupServices

```
[ //localhost/Radius/Services/AccountingGroupService/GroupServices ]
```

set 1 OurAccountingService

```
Set 1 OurAccountingService
```

Set 2 TheirAccountingService

```
Set 2 TheirAccountingService
```

Is

```
[ //localhost/Radius/Services/AccountingGroupService ]
Name = AccountingGroupService
Description =
Type = group
IncomingScript = AcctGroupSvcInScript
OutgoingScript = AcctGroupSvcOutScript
ResultRule = AND
GroupServices/
    1. OurAccountingService
    2. TheirAccountingService
```

This completes the setup of the AccountingGroupService. To use this Service simply set it as the DefaultAccountingService and/or configure a policy/rule set which will select this Service. Essentially, this can be used in the same manner as any other standalone service.

Summary of Events

The following describes the flow of what happens when a client sends an accounting request which is processed by the AccountingGroupService:

1. ActGroupSvcInScript is executed.
2. OurAccountingService is called.
3. OurAccountingService's Incoming Script, OurAccountingInScript is called.
4. The request is sent to the Remote Server OurPrimaryServer and/or OurSecondaryServer, if necessary.
5. If a response is not received, because we used the **AND** ResultRule, the request failed and no response is sent to the client and the request is dropped. If a response is received, then the process continues.
6. OurAccountingService's Outgoing Script, OurAccountingOutScript is called.
7. TheirAccountingService is called.
8. TheirAccountingService's Incoming Script, TheirAccountingInScript is called.
9. The request is sent to the Remote Server TheirPrimaryServer and/or TheirSecondaryServer, if necessary.
10. If a response is not received, because we used the **AND** ResultRule, the request failed and no response is sent to the client and the request is dropped. If a response is received, then the process continues.
11. TheirAccountingService's Outgoing Script, TheirAccountingOutScript is called.
12. AcctGroupSvcOutScript is executed.
13. Standard processing continues.

Configuration Example 2 - AuthenticationGroupService

To configure a Group Service for the purposes of providing alternate Remote Servers for a single authentication:

**Note**

Supposingly, if Service A rejects the request, try Service B.

- Step 1** The first task is to set up the subservices which are to be part of the AuthenticationGroupService. Since subservices are merely configured Services which have been included in a service group, we will simply define two new Services. For simplicity, we will define two new radius Services called AuthenticationServiceA and AuthenticationServiceB.
- Step 2** At the command line, enter the following:

cd /radius/services

```
[ //localhost/Radius/Services ]
  Entries 1 to 2 from 2 total entries
  Current filter: <all>
  local-file/
  local-users/
```

add AuthenticationServiceA**add AuthenticationServiceB**

Step 3 The configuration of these Services is very similar to standalone Radius authentication service. Step-by-step configuration instructions are not provided, but the complete configuration is shown below:

```
[ //localhost/Radius/Services/AuthenticationServiceA ]
  Name = AuthentictionServiceA
  Description =
  Type = radius
  IncomingScript = AuthAInScript
  OutgoingScript = AuthAOutScript
  OutagePolicy = RejectAll
  OutageScript = AuthAOutageScript
  MultipleServersPolicy = Failover
  RemoteServers/
    1. PrimaryServerA
    2. SecondaryServerA

[ //localhost/Radius/Services/AuthenticationServiceB ]
  Name = AuthentictionServiceB
  Description =
  Type = radius
  IncomingScript = AuthBInScript
  OutgoingScript = AuthBOutScript
  OutagePolicy = RejectAll
  OutageScript = AuthBOutageScript
  MultipleServersPolicy = Failover
  RemoteServers/
    1. PrimaryServerB
    2. SecondaryServerB
```

The next step is to create the new "AuthenticationGroupService". The purpose of this Service is to process authentication requests through both AuthenticationServiceA and AuthenticationServiceB if AuthenticationServiceA rejects the request.

Step 4 At the command line, enter the following:

add AuthenticationGroupService

```
Added AuthenticationGroupService
```

cd AuthenticationGroupService

```
[ //localhost/Radius/Services/AuthenticationGroupService ]
  Name = AuthenticationGroupService
  Description =
  Type =
  IncomingScript =
  OutgoingScript =
```

set type group

```
Set Type group
```

Next set the ResultRule to **OR** because we want to ensure that if the first subservice rejects the request, we then try the second subservice. If the second subservice rejects the request, then the response to the client is a reject.

Step 5 At the command line, enter the following:

set ResultRule OR

```
Set ResultRule OR
```

Set IncomingScript AuthGroupSvcInScript

```
Set OutgoingScript AuthGroupSvcOutScript
```

Set IncomingScript AuthGroupSvcInScript

```
Set OutgoingScript AuthGroupSvcOutScript
```

ls

```
[ //localhost/Radius/Services/AuthenticationGroupService ]
  Name = AuthenticationGroupService
  Description =
  Type = group
  IncomingScript = AuthGroupSvcInScript
  OutgoingScript = AuthGroupSvcOutScript
  ResultRule = OR
  GroupServices/
```

Now we must add the services we created "AuthenticationServiceA" and "AuthenticationServiceB" as subservices of the Group Service.

Step 6 At the command line, enter the following:

cd GroupServices

```
[ //localhost/Radius/Services/AuthenticationGroupService/GroupServices ]
```

set 1 AuthenticationServiceA

```
Set 1 AuthenticationServiceA
```

Set 2 AuthenticationServiceB

```
Set 2 AuthenticationServiceB
```

Is

```
[ //localhost/Radius/Services/AuthenticationGroupService ]
  Name = AuthenticationGroupService
  Description =
  Type = group
  IncomingScript = AuthGroupSvcInScript
  OutgoingScript = AuthGroupSvcOutScript
  ResultRule = OR
  GroupServices/
    1. AuthenticationServiceA
    2. AuthenticationServiceB
```

This completes the setup of the AuthenticationGroupService. To use this Service simply set it as the DefaultAuthenticationService and/or configure a policy/rule set which will select this Service. Essentially, this can be used in the same manner as any other standalone Service.

Summary of Events

The following describes the flow of what happens when a client sends an Authentication request which is processed by the AuthenticationGroupService:

1. AuthGroupSvcInScript is executed.
2. AuthenticationServiceA is called.
3. AuthenticationServiceA's Incoming Script, AuthAInScript is called.
4. If the response is a reject or the request is dropped (due to an Outage Policy):
 - a. AuthenticationServiceA's Outgoing Script, AuthAOutScript is called.
 - b. Processing continues with the next service.
5. If the response is an Accept:
 - a. AuthenticationServiceA's Outgoing Script, AuthAOutScript is called.
 - b. Skip to step 9.
6. AuthenticationServiceB is called.
7. AuthenticationServiceB's Incoming Script, AuthBInScript is called.

8. Since this is the last subservice in our Group Service:
 - a. AuthenticationServiceB's Outgoing Script, AuthBOutScript is called.
 - b. Regardless of whether the request is Accepted or Rejected, processing will continue at step 9.
9. AuthGroupSvcOutScript is executed.
10. Standard processing continues.

SHA-1 Support for LDAP-Based Authentication

The Cisco Prime AR server supports secure hash algorithm (SHA-1) for LDAP-based authentication. This feature enables the Cisco Prime AR server to authenticate users whose passwords are stored in LDAP servers and hashed using the SHA-1 encoding scheme.

SHA-1 support actually adds functionality for the following three features to Cisco Prime AR:

- Authentication of PAP access requests against an LDAP user entry that uses the SHA-algorithm to the hash password attribute
- Authentication of PAP access requests against an LDAP user entry that uses the SSHA algorithm to hash the password attribute
- Configuration of the Cisco Prime AR server to dynamically determine how password attributes retrieved from LDAP are encrypted and process them accordingly

This enhancement is 100% backwards compatible. All previously supported values for the PasswordEncryptionStyle property are still supported and still provide the same behavior. The only noticeable change is that **dynamic** is now the default value for the PasswordEncryptionStyle property.

This section contains the following topics:

- [Remote LDAP Server Password Encryption](#)
- [Dynamic Password Encryption](#)
- [Logs](#)

Remote LDAP Server Password Encryption

Apart from the two values, none and crypt, of the PasswordEncryptionStyle property on a Remote LDAP Server, SHA-1 supports adds three additional values for the PasswordEncryptionStyle property. [Table 17-2](#) lists the valid values for this property and describes the corresponding behavior.

Table 17-2 Remote LDAP Server Password Encryption Style Values

PasswordEncryptionStyle	Cisco Prime Access Registrar Behavior
none	All passwords retrieved from this LDAP server are assumed to be returned to Cisco Prime AR as clear text. (There is no change in this functionality.)
crypt	All passwords retrieved from this LDAP server are assumed to be returned to Cisco Prime AR as passwords encrypted using the UNIX <i>crypt</i> algorithm. (There is no change in this functionality.) Passwords can be preceded by the {crypt} prefix, which is stripped before comparing passwords.

Table 17-2 Remote LDAP Server Password Encryption Style Values (continued)

PasswordEncryptionStyle	Cisco Prime Access Registrar Behavior
SHA-1	<p>All passwords retrieved from this LDAP server are assumed to be returned to Cisco Prime AR as a Base64-encoded version of the user's password after it has been hashed using the SHA-1 mechanism (as defined by Netscape).</p> <p>Passwords can be preceded by the {sha} prefix, which is stripped before comparing passwords.</p>
SSHA-1	<p>All passwords retrieved from this LDAP server are assumed to be encrypted/hashed using the SSHA mechanism (as defined by Netscape). Passwords can be preceded by the {ssha} prefix, which is stripped before comparing passwords.</p> <p>Note This is a Netscape/iPlanet-specific mechanism.</p>
dynamic	<p>The value instructs Cisco Prime AR to choose the encryption mechanism on a case-by-case basis after it determines the presence of a known prefix, which the LDAP server prepends to the value of the password attribute.</p> <p>For example, if the following was returned from an LDAP server as a password attribute: {SHA }qZk+NkcGgWq6PiVxeFDCbJzQ2J0=, the password would be processed using the SHA-1 mechanism. This value will be the new default for the PasswordEncryptionStyle property.</p>

Dynamic Password Encryption

When using the dynamic setting for the PasswordEncryptionStyle property on a Remote LDAP Server, the Cisco Prime AR server looks for the prefixes listed in [Table 17-3](#) to determine if encryption or a hash algorithm should be used during password comparison.

Note

Password prefixes are not case-sensitive.

Table 17-3 Remote LDAP Server Password Prefix Values

Password Prefix	Encryption/Hash Algorithm Used
none	None; when no known prefix is found, the password attribute is assumed to be in clear text.
{crypt}	UNIX crypt algorithm
{sha}	Secure Hash Algorithm, version 1 (SHA-1)
{ssha}	SSHA-1, as defined by Netscape.

The default value for the PasswordEncryptionStyle property on a Remote LDAP Server is **dynamic**.

**Note**

Using the *dynamic* setting for the PasswordEncryptionStyle property will require a bit more processing for each password comparison. When using dynamic, the Cisco Prime AR server must examine each password for a known prefix. This should have no visible impact on performance.

Logs

Turn on **trace** to level 4 to indicate (via the trace log) which password comparison method is being used.

Dynamic Attributes

Cisco Prime AR supports dynamic values for the configuration object properties listed below. Dynamic attributes are similar to UNIX shell variables. With dynamic attributes, the value is evaluated at run time. All of the objects that support dynamic attributes will have validation turned off in **aregcmd**.

This section contains the following topics:

- [Object Properties with Dynamic Support](#)
- [Dynamic Attribute Format](#)
- [Configuration](#)
- [Example](#)
- [Notes](#)
- [Validation](#)

Object Properties with Dynamic Support

The following object properties support dynamic values:

Radius

DefaultAuthenticationService

DefaultAuthorizationService

DefaultAccountingService

DefaultSessionManager

IncomingScript

OutgoingScript

**Note**

Do not use the following environment variables:

Accounting-Service for the **/Radius/DefaultAccountingService**, Authentication-Service for the **/Radius/DefaultAuthenticationService**, or Authorization-Service for the **/Radius/DefaultAuthorizationService**

User-Profile for the **BaseProfile**, User-Group for the **Group**, User-Authorization for the **AuthorizationScript**, Session-Manager for the **DefaultSessionManager**, or Session-Service for the **DefaultSessionService**.

```

/Radius/Clients
  client1/
    IncomingScript
    OutgoingScript
/Radius/Userlist/Default
  user1/
    Group
    BaseProfile
    AuthenticationScript
    AuthorizationScript
/Radius/UserGroup
  Group1/
    BaseProfile
    AuthenticationScript
    AuthorizationScript
/Radius/Vendor
  Vendor1/
    IncomingScript
    OutgoingScript
/Radius/Service
  Service1/
    IncomingScript
    OutgoingScript
    OutageScript
    OutagePolicy
/Radius/RemoteServers
  remoteserver1/
    IncomingScript
    OutgoingScript
  Remoteldapservers1/
    Searchpath
    Filter

```



Note To differentiate the properties that support dynamic attributes, we place a tilde (~) after each property, as in IncomingScript~. However, when the Cisco Prime AR administrator is required to set values for those properties, continue to use the original property name, such as set IncomingScript \${elrealm}{Test}. The tilde is only for visual effect, and including the tilde will generate an error (“310 command Failed.”)

Dynamic Attribute Format

The format of the dynamic attribute is:

```
#{eq|attribute-name}{default-name}
```

where **e** stands for environment dictionary, **q** stands for request dictionary, and **p** stands for response dictionary. You can use e, q, and p in any order. The attribute name is the name for the attribute from environment dictionary, request dictionary, or response dictionary.

For example,

```
/Radius
DefaultAuthenticationService = #{eq|realm}{local-users}
```

The default Authentication Service is determined at run time. Cisco Prime AR first checks to see if there is one value of *realm* in the environment dictionary. If there is, it becomes the value of DefaultAuthenticationService. If there is not, check the value of realm in the request dictionary. If there is one value, it becomes the value of DefaultAuthenticationService. Otherwise, local-users is the DefaultAuthenticationService. If we do not set local-users as the default value, the DefaultAuthenticationService is *null*. The same concept applies to all other attribute properties.

The validation for the dynamic values of the object property will only validate the default value. In the above example, Cisco Prime AR will do validation to check whether local-users is one of services defined in the service subdirectory.



Note

When setting specific property values, do not use the tilde (~) in the property name. Doing so generates a *310 Command Failed* error.

Tunneling Support Feature

Tunneling support is strictly based upon the IETF RFC: “RADIUS Attributes for Tunnel Protocol Support” (<http://www.ietf.org/rfc/rfc2868.txt>).

Table 17-4 lists the tunneling attributes supported in this Cisco Prime AR release.

Table 17-4 Tunneling Attributes Supported by Cisco Prime AR

Attribute Number	Attribute
64	Tunnel-Type
65	Tunnel-Medium-Type
66	Tunnel-Client-Endpoint
67	Tunnel-Server-Endpoint
69	Tunnel-Password
81	Tunnel-Private-Group-ID
82	Tunnel-Assignment-ID
83	Tunnel-Preference
90	Tunnel-Client-Auth-ID
91	Tunnel-Server-Auth-ID

The tunneling attribute has the following format:

(1 byte)	(1 byte)	(1 byte)	(variable number of bytes)
Type	Length	Tag	Value

This section contains the following topics:

- [Configuration](#)
- [Example](#)
- [Notes](#)
- [Validation](#)

Configuration

1. Configure the tag attributes as untagged attributes under the **/Radius/Advanced/Attribute Dictionary** directory (for example, **Tunnel-Type**).
2. Attach the “**_tag**” tag to these attributes when configuring the attributes under all of the other directories as tagged attributes (for example, **Tunnel-Type_tag10** under the **/Radius/Profiles/test** directory). Without the tag number, the default value is (**_tag = _tag0**).

Example

```

/Radius/Advanced/Attribute Dictionary
  /Tunnel-Client-ID
    Name = Tunnel-Client-Endpoint
    Description =
    Attribute = 66
    Type = STRING
    Min = 0
    Max = 253

/Radius/Profiles/test
  Name = test
  Description =
  /Attributes
    Tunnel-Client-Endpoint_tag3 = "129.56.112.1"

```

Notes

1. “**_tag**” is reserved for the tunneling attributes. No other attributes should include this suffix.
2. The tag number value can range from 0 through 31.

Validation

The Cisco Prime AR server checks whether the tag attributes are defined under the **/Radius/Advanced/Attribute Dictionary** directory. The server also checks whether the tag number falls within the range (0-31).

xDSL VPI/VCI Support for Cisco 6400

To provide this support, a distinction must be made between device authentication packets and regular user authentication packets. This section contains the following topics:

- [Using User-Name/User-Password for Each Cisco 6400 Device](#)
- [Format of the New User-Name Attribute](#)

Using User-Name/User-Password for Each Cisco 6400 Device

This approach assumes that for every 6400 NAS, a device-name/device-password is created for each. Following are the required changes:

For each NAS in Cisco Prime AR:

```
Name = test6400-1
Description =
IPAddress = 209.165.200.224
SharedSecret = secret
Type = NAS
Vendor =
IncomingScript =
OutgoingScript =
Device-Name = theDevice
Device-Password = thePassword
```

When the 6400 sends out the device authentication packet, it might have different **User-Name/User-Password** attributes for each 6400 NAS. When Cisco Prime AR receives the packet, it tries to obtain the **Device-Name/Device-Password** attributes from the NAS entry in the Cisco Prime AR configuration database. When the **User-Name/User-Password** in the packet match the configured **Device-Name/Device-Password** attribute values, Cisco Prime AR assumes that it must get the device. The next step is to replace the **User-Name** attribute with the concatenated `<module>/<slot>/<port>` string. From this point, the packet is treated as a regular packet.



Note

A user record with the name of the concatenated string must be created.

Format of the New User-Name Attribute

After the device is identified, the **User-Name** attribute is replaced with the new value. This new value is the concatenation of 6400 `<module>/<slot>/<port>` information from the NAS-Port attribute and the packet is treated as a regular user authentication from this point on.



Note

This format only supports NAS Port Format D. See Cisco IOS documentation for more information about NAS port formats.

The format of the new **User-Name** attribute is the **printf** of “%s-%d-%d-%d-%d” for the following values:

NAS-IP—in dot format of the **NAS-IP-Address** attribute. For example, 10.10.10.10.

slot—apply mask 0xF0000000 on **NAS-Port** attribute and shift right 28 bits. For example, **NAS-Port** is 0x10000000, the slot value is 1.

module—apply mask `0x08000000` on **NAS-Port** attribute and shift right 27 bits. For example, **NAS-Port** is `0x08000000`, the **module** value is 1.

port—apply mask `0x07000000` on **NAS-Port** attribute and shift right 24 bits. For example, **NAS-Port** is `0x06000000`, the **port** value is 6.

VPI—apply mask `0x00FF0000` on **NAS-Port** attribute and shift right 16 bits. For example, **NAS-Port** is `0x00110000`, the **VPI** value is 3.

VCI—apply mask `0x0000FFFF` on **NAS-Port** attribute. For example, **NAS-Port** is `0x00001001`, the **VCI** value is 9.

Apply Profile in Cisco Prime Access Registrar Database to Directory Users

You can define the **User-Profile** and **User-Group** environment variables in the directory mapping and Cisco Prime AR will apply the profiles defined in the Cisco Prime AR database to each directory user having any of these two variables set.

This section contains the following topics:

- [User-Profile](#)
- [User-Group](#)
- [Example User-Profile and User-Group Attributes in Directory User Record](#)

User-Profile

This attribute is of type string with the format:

`<Value1>::<>Value2> ...`

The **User-Profile** attribute is intended to hold a list of profile names. `<Value1>` and `<Value2>` represent the names of the profiles. They are separated by the “::” character, therefore, the “::” can not be part of the profile name. The order of values in the string has significance, as the profiles are evaluated from left to right. In this example, profile `<Value2>` is applied after profile `<Value1>`.

Assume the user record has a field called `UserProfile` that holds the name of the profile that applies to this user. This field is mapped to the environment attribute **User-Profile**. Following is how the mapping is done with **aregcmd**:

```
QuickExample/
  Name = QuickExample
  Description =
  Protocol = ldap
  IPAddress = 209.165.200.224
  Port = 389
  ReactivateTimerInterval = 300000
  Timeout = 15
  HostName = QuickExample.company.com
  BindName =
  BindPassword =
  UseSSL = FALSE
  SearchPath = "o=Ace Industry, c=US"
  Filter = (uid=%s)
  UserPasswordAttribute = password
  LimitOutstandingRequests = FALSE
```

```

MaxOutstandingRequests = 0
MaxReferrals = 0
ReferralAttribute =
ReferralFilter =
PasswordEncryptionStyle = None
LDAPToEnvironmentMappings/
    UserProfile = User-Profile
LDAPToRadiusMappings/

```

After Cisco Prime AR authenticates the user, it checks whether **User-Profile** exists in the environment dictionary. If it finds **User-Profile**, for each value in **User-Profile**, Cisco Prime AR looks up the profile object defined in the configuration database and adds all of the attributes in the profile object to the response dictionary. If any attribute is included in more than one profile, the newly applied profile overrides the attribute in the previous profile.

User-Group

You can use the **User-Group** environment variable to apply the user profile as well. In Cisco Prime AR, a user can belong to a user group, and that user group can have a pointer to a user profile. When Cisco Prime AR finds that a packet has **User-Group** set, it obtains the value of the **User-Profile** within the user group, and if the **User-Profile** exists, it applies the attributes defined in the user profile to that user.

Note that in Cisco Prime AR, every user can also directly have a pointer to a user profile. Cisco Prime AR applies profiles in the following order:

1. If the user profile defined in the user group exists, apply it.
2. If the user profile defined in the user record exists, apply it.

The profile in **User-Group** is more generic than in **User-Profile**. Therefore, Cisco Prime AR applies the profile from generic to more specific.

Example User-Profile and User-Group Attributes in Directory User Record

You can use an existing user attribute in the user record to store profile info. When this is a new attribute, we suggest you create a new auxiliary class **AR_UserRecord** for whichever user class is used.

AR_User_Profile and **AR_User_Group** are two optional members in this class. They are of type string. The mapping is as follows:

```

LDAPToEnvironmentMappings/
    AR_User_Profile = User-Profile
    AR_User_Group = User-Group

```

Directory Multi-Value Attributes Support

If any attributes mapped from the LDAP directory to the Cisco Prime AR response dictionary are multivalued, the attributes are mapped to multiple RADIUS attributes in the packet.

MultiLink-PPP (ML-PPP)

Cisco Prime AR supports MultiLink-PPP (ML-PPP). ML-PPP is an IETF standard, specified by RFC 1717. It describes a Layer 2 software implementation that opens multiple, simultaneous channels between systems, providing additional bandwidth-on-demand, for additional cost. The ML-PPP standard describes how to split, recombine, and sequence datagrams across multiple B channels to create a single logical connection. The multiple channels are the ports being used by the Network Access Server (NAS).

During the AA process, Cisco Prime AR authenticates the user connection for each of its channels, even though they belong to the same logical connection. The Authentication process treats the multilink connection as if it is multiple, single link connections. For each connection, Cisco Prime AR creates a session dedicated for management purposes. The session stays active until you logout, which subsequently frees up all of the ports in the NAS assigned to each individual session, or until the traffic is lower than a certain threshold so that the secondary B channels are destroyed thereafter. Cisco Prime AR has the responsibility of maintaining the active session list and discards any session that is no longer valid in the system, by using the accounting stop packet issued from NAS. The multiple sessions that were established for a single logical connection must be destroyed upon the user logging out.

In addition, the accounting information that was gathered for the sessions must be aggregated for the corresponding logical connection by the accounting software. Cisco Prime AR is only responsible for logging the accounting start and accounting stop times for each session. As those sessions belong to the same bundle, IETF provides two standard RADIUS attributes to identify the related multilink sessions. The attributes are **Acct-Multi-Session-Id** (attribute **50**) and **Acct-Link-Count** (attribute **51**), where **Acct-Multi-Session-Id** is a unique Accounting identifier used to link multiple related sessions in a log file, and **Acct-Link-Count** provides the number of links known to have existed in a given multilink session at the time the Accounting record was generated. The Accounting software is responsible for calculating the amount of the secondary B channel's connection time.

The secondary B channel can go up and down frequently, based upon traffic. The Ascend NAS supports the **Target-Util** attribute, which sets up the threshold for the secondary channel. When the traffic is above that threshold the secondary channel is up, and when the traffic is below that threshold, the secondary B channel is brought down by issuing an Accounting stop packet to Cisco Prime AR. On the other hand, if you bring down the primary channel (that is, log out), the secondary B channel is also destroyed by issuing another Accounting stop packet to Cisco Prime AR.

Table 17-5 lists ML-PPP related attributes.

Table 17-5 ML-PPP Attributes

Number	Attribute	Cisco NAS (IOS 11.3 Release)	Ascend NAS
44	Acct-Session-Id	Supported	Supported
50	Acct-Multi-Session-Id	Supported	Supported
51	Acct-Link-Count	Supported	Supported
62	Port-Limit	Supported	Supported
124	Target-Util	Not Supported	Supported
125	Maximum-Channels	Supported	Supported

Following are sample configurations for ML-PPP:

```

/RADIUS
 /Profile
   /Default-ISDN-Users
     Name = Default-ISDN-Users
     Description =
     Attributes/

```

```

Port-Limit = 2
Target-Util = 70
Session-Timeout = 70

/Radius
  /UserGroups
    /ISDN-Users
      Name = ISDN-Users
      Description = " Users who always use ISDN"
      BaseProfile = Default-ISDN-Users
      Authentication-Script =
      Authorization-Script =

```

The **Port-Limit** attribute controls the number of concurrent sessions a user can have. The **Target-Util** attribute controls the threshold level at which the second B channel should be brought up.

Dynamic Updates Feature

The Dynamic Updates feature enables changes to server configurations made using **aregcmd** to take effect in the Cisco Prime AR server after issuing the **save** command, eliminating the need for a server **reload** after making changes.

[Table 17-6](#) lists the Radius object and its child objects. For each object listed, the **Add** and **Modify or Delete** columns indicate whether a dynamic update occurs after adding, modifying, or deleting an object or attribute. Entries in the **Add** and **Modify or Delete** columns also apply to child objects and child attributes of the objects listed, unless the child object is explicitly listed below the object, such as **/Radius/Advanced/Ports** or **/Radius/Advanced/Interfaces**.

Table 17-6 Dynamic Updates Effect on Radius Server Objects

Object	Add	Modify or Delete
Radius	Yes	Yes
UserLists	Yes	Yes
UserGroups	Yes	Yes
Policies	Yes	Yes
Clients	Yes	Yes
Vendors	Yes	Yes
Scripts	Yes	Yes
Services	Yes	Yes
SessionManagers	Yes	No
ResourceManagers	Yes	No
Profiles	Yes	Yes
Rules	Yes	Yes
Translations	Yes	Yes
TranslationGroups	Yes	Yes
RemoteServers	Yes	No
Replication	No	No

Table 17-6 Dynamic Updates Effect on Radius Server Objects (continued)

Object	Add	Modify or Delete
Advanced	Yes	Yes
SNMP	No	No
Ports	No	No
Interfaces	No	No

The Dynamic Updates feature is subject to the following limitations:

- Changes to the Ports or Interfaces objects are not dynamically updated. An **aregcmd reload** command must be issued for these changes to be propagated to the Cisco Prime AR server.
- Changes (modifications and deletions) to existing Session Manager and Resource Manager objects are not dynamically updated. An **aregcmd reload** command must be issued for these changes to be propagated to the Cisco Prime AR server. However, additions of new Session Manager and Resource Manager objects are dynamically updated. Active sessions and allocated resources are preserved in this case.
- Changes to the Cisco Prime AR configuration might not be immediately propagated to the server. Dynamic updates are only carried out in a *safe* environment (that is, when packets are not being processed and when packet processing can be delayed until the changes can be made on the server safely). Dynamic updates will yield to packet processing when appropriate, thus not significantly impacting server performance.
- Changes to SNMP require the Cisco Prime AR server to be restarted (**/etc/init.d/arservagt restart**)

NAS Monitor

The ability to monitor when a NAS is *down* (really only unreachable from Cisco Prime AR) is provided by **nasmonitor**. This program will repeatedly query a TCP port at the specified IP address until the device (NAS) is reachable. If the NAS is not reachable after a period of time, a warning e-mail is sent; if the NAS is still not reachable after another period of time, a message is sent to Cisco Prime AR to release all sessions associated with that NAS. The port to query, the query frequency, the first time interval, the back-off time interval, and the E-mail address to send to are all configurable (with defaults); the only required parameter is the NAS IP address. This program will work for any device that has a TCP port open; it can either be run by hand, when desired, or put in a **cron** job. See **nasmonitor -h** for details.



Note

You must have **tcsh** installed in **/usr/local/bin** to use **nasmonitor**. **tcsh** is part of the standard Tcl installation that can be downloaded from <http://www.scriptics.com>.

Automatic Information Collection (arbug)

You can use the script **arbug** to collect information about your Cisco Prime AR server. The results are collected into a tarball that can be e-mailed or **ftped** to Cisco as requested.

arbug collects all the relevant information needed to report a problem to Cisco Prime AR support. The goal of the **arbug** script is to make sure all the necessary information is collected.

**Note**

The **arbug** script neither updates nor replaces any system or Cisco Prime AR-related configuration.

This section contains the following topics:

- [Running arbug](#)
- [Files Generated](#)

Running arbug

To run the **arbug** script, change directory to **/cisco-ar/bin** and enter the following:

```
./arbug
```

The following is a typical sequence.

```
Looking around...
Cluster:
User: admin
Password:
The report /tmp/arbug.10085/arbug.tar is ready to send; you
may want to compress it first using gzip or compress.
hostname user_name bin>
```

Files Generated

The **arbug** script generates five files that are compressed into a tarball. [Table 17-7](#) provides a summary of the information found in each of the files.

Table 17-7 Files Generated by arbug

File	Description
car.debug.tar.*	Machine-specific information including OS type, RAM details, disk space information, swap space information, patch information and open file details.
car.config.tar.*	Cisco Prime AR server configuration, server statistics, database dump by taking the administrator username and password as the input.
car.confini.tar.*	Information about ODBC .ini files and SNMP configuration
car.core.tar.*	Core files if any are present
car.logcscrtar.*	Information from scripts directory, certificate directory, license directory

Simultaneous Terminals for Remote Demonstration

Multiple people can view and interact in a single demonstration by using the *share-access* program, a standard GNU release with a special configuration for use with Cisco Prime AR. To run **screen**, a technical support specialist (CSE or DE) will **telnet** to your server and log in as *cisco*. While you run **/opt/CSCOAr/bin/share-access** (assuming **/opt/CSCOAr** is the Cisco Prime AR path) as *root*, the CSE or DE runs **/opt/CSCOAr/bin/share-access -r root**. Now both people (or more) can see what the other types, as well as the results of the commands entered. The special Cisco Prime AR configuration only allows *root* and *cisco* to run **screen**. To end a **share-access** session, type Control-D.

Support for RADIUS Check Item Attributes

Cisco Prime AR supports RADIUS check item attributes configuration at the user and group levels. You can configure the Cisco Prime AR server to check for attributes that must be present or attributes that must not be present in the Access-Request packet for successful authentication.

When using check item attributes, the Cisco Prime AR server will reject Access-Requests if:

- Any of the configured check item attributes are not present in the Access-Request packet
- Any of the Access-Request packet's check item attribute values do not match with those configured check item attribute values

For remote servers using either LDAP or ODBC, Cisco Prime AR allows for mapping of certain LDAP or ODBC fields to check item attributes. The mapped attributes can be used as check item attributes while processing the Access-Request packets.

When you configure check item attributes at both the user and group levels, the Cisco Prime AR server first checks the attributes of the user level before those of the group level. The Cisco Prime AR server must first authenticate the user's password in the Access-Request before validating the check item attributes.

The Cisco Prime AR server logs details about any rejected Access-Requests as a result of check items processing.

Configuring Check Items

You use **aregcmd** to configure check item attributes.

Configuring User Check Items

To configure UserList check item attributes:

-
- Step 1** Log into the Cisco Prime AR server, and use **aregcmd** to navigate to **//localhost/Radius/UserLists/default/bob**.

```
[ //localhost/Radius/UserLists/Default/bob ]
Name = bob
Description =
Password = <encrypted>
AllowNullPassword = FALSE
Enabled = TRUE
Group~ = PPP-users
BaseProfile~ =
AuthenticationScript~ =
```

```

AuthorizationScript~ =
UserDefined1 =
Attributes/
CheckItems/

```

Step 2 Change directory to CheckItems.

```
cd CheckItems
```

```
[ //localhost/Radius/UserLists/Default/bob/CheckItems ]
```

Step 3 Use set to add any attributes to be used as check items.

```
set calling-Station-Id 4085551212
```

```
save
```

Configuring Usergroup Check Items

To configure UserGroups check item attributes:

Step 1 Log into the Cisco Prime AR server, and use **aregcmd** to navigate to **//localhost/Radius/UserGroups/Default**.

```
cd /Radius/UserGroups/Default
```

```
[ //localhost/Radius/UserGroups/Default ]
Name = Default
Description = "Users who sometimes connect using PPP and sometimes connect "
BaseProfile~ =
AuthenticationScript~ =
AuthorizationScript~ = AuthorizeService
Attributes/
CheckItems/

```

Step 2 Change directory to CheckItems.

```
cd CheckItems
```

```
[ //localhost/Radius/UserGroups/Default/CheckItems ]
```

Step 3 Use set to add any attributes to be used as check items.

```
set NAS-IP-Address 10.10.10.10
```

```
save
```

User-Specific Attributes

The Cisco Prime AR server supports user-specific attributes which enables the Cisco Prime AR server to return attributes on a per-user or per-group basis without having to use profiles.

The Cisco Prime AR server includes a property called `HiddenAttributes` to the `User` and `UserGroup` object. The `HiddenAttributes` property contains a concatenation of all user-level reply attributes. The `HiddenAttributes` property is not displayed, nor can the value be set or unset using the command-line interface.

The order of application of attributes is as follows:

1. `UserGroup Base Profile`
2. `UserGroup Attributes`
3. `User Base Profile`
4. `User Attributes`

The value of the `HiddenAttributes` property is used dynamically to construct and populate a virtual *attributes* directory in the `User` object. All values from the `Attributes` directory will go into the `HiddenAttributes` property. This occurs transparently when the administrator issues a `save` command.

Packet of Disconnect

Cisco Prime AR supports the Packet of Disconnect (POD) feature that enables the Cisco Prime AR server to send disconnect requests (PODs) to a NAS so that all the session information and the resources associated with the user sessions can be released. Cisco Prime AR can also determine when to trigger and send the POD.

For example, when a PDSN handoff occurs during a mobile session, the new PDSN sends out a new access-request packet to Cisco Prime AR for the same user. Cisco Prime AR should detect this handoff by the change in `NAS-Identifier` in the new request and trigger sending a POD to the old PDSN if it supports POD. Cisco Prime AR also provides an option for administrator to initiate sending POD requests through the command-line interface (CLI) for any user session. Cisco Prime AR forwards POD requests from external servers to the destination NAS.

This section contains the following topics:

- [Configuring Packet of Disconnect](#)
- [Proxying POD Requests from External Servers](#)
- [CLI Options for POD](#)

Configuring Packet of Disconnect

This section describes how to configure the POD feature in the following:

- [Configuring the Client Object](#)
- [Configuring a Resource Manager for POD](#)

Configuring the Client Object

You should enable POD for each client object that might want to send disconnect requests to those clients. You enable POD in a client object using the `EnableDynamicAuthorization` property. This property is set to `FALSE` by default when you create a client object. The following example shows the default configuration for a new client object, `NAS1`.

```
[ //localhost/Radius/Clients/NAS1 ]
  Name = nas1
  Description =
  IPAddress =
  SharedSecret =
  Type = NAS
  Vendor =
  IncomingScript~ =
  OutgoingScript~ =
  EnableDynamicAuthorization = FALSE
```

If the Cisco Prime AR server might send a POD to this client, set the `EnableDynamicAuthorization` property to `TRUE`. When you set this property to `TRUE`, the Cisco Prime AR server creates a `DynamicAuthorizationServer` subdirectory under the client object. The following example shows a newly created `DynamicAuthorizationServer` subdirectory:

```
[ //localhost/Radius/Clients/NAS1/DyanamicAuthorizationServer ]
  Port = 3799
  DynamicAuthSharedSecret =
  InitialTimeout = 5000
  MaxTries = 3
  PODAttributeGroup =
  COAAttributeGroup =
```

The default port is 3799. You can change the port, if desired.

The property `DynamicAuthSharedSecret` is initially set to the same as value as the client's `SharedSecret` property when you set `EnableDynamicAuthorization` to `TRUE`. You can chose to configure a different secret for POD in this subdirectory.

The `InitialTimeout` property represents the number of milliseconds used as a timeout for the first attempt to send a POD packet to a remote server. For each successive retry on the same packet, the previous timeout value used is doubled. You must specify a number greater than zero, and the default value is 5000 (or 5 seconds).

The `MaxTries` property represents the number of times to send a proxy request to a remote server before deciding the server is offline. You must specify a number greater than zero, and the default is 3.

The `PODAttributeGroup` property points to a group of attributes to be included in a disconnect-request packet sent to this client.

You can create and configure the `PODAttributeGroup` in the `/Radius/Advanced/AttributeGroups/` directory. The default group contains commonly used POD attributes `NAS-Port` and `Acct-Session-Id`.

The `COAAttributeGroup` property is used with the Change of Authorization (CoA) feature, also known as hot-lining.

Configuring a Resource Manager for POD

Cisco Prime AR provides a resource manager type called *session-cache*. When you set a resource manager to *session-cache*, the resource manager's configuration contains a subdirectory called *AttributesToBeCached*. The following is an example Resource Manager set to type *session-cache*:

```
[ //localhost/Radius/ResourceManagers/PODresourceMgr ]
  Name = PODresourceMgr
  Description =
  Type = session-cache
  OverwriteAttributes = FALSE
  AttributesToBeCached/
  QueryMappings/
```

The attributes you configure under the **AttributesToBeCached** directory are cached in the session record during session management. The cached attributes are then sent in the disconnect-request for this session.

The `OverwriteAttributes` property indicates whether to overwrite the existing attributes if there are any in the session record. Since this resource manager can be invoked during `Access-Request` as well as `Accounting-Start` processing, the `OverwriteAttributes` can be used to control if the attributes cached during `Access-Request` processing can be overwritten with the attributes available during `Accounting-Start` processing.

The following is an example of a typical session-cache resource manager:

```
[ //localhost/Radius/ResourceManagers/RM-New ]
  Name = RM-New
  Description =
  Type = session-cache
  OverwriteAttributes = TRUE
  AttributesToBeCached/
    1. Framed-IP-Address
    2. CDMA-Correlation-ID
  QueryMappings/
```

The attributes used in the example can be added as an indexed list using **add** or **set** commands (in any order).

Proxying POD Requests from External Servers

Cisco Prime AR can also proxy the disconnect requests received from external servers. To make Cisco Prime AR listen for external POD requests, the `ListenForDynamicAuthorizationRequests` property under **/Radius/Advanced** should be set to `TRUE`. The default value for this is `FALSE`. The default POD listening port is 3799. However this can be changed by configuring a new port of type *pod* under **/Radius/Advanced/Ports** and setting the new port number accordingly.

For security reasons, the source of a POD request should be configured as a remote server in Cisco Prime AR and the remote server should be configured to accept PODs. Set the property `AcceptDynamicAuthorizationRequests` to `TRUE` to do this. The default for this is `FALSE`. POD requests from unauthorized sources are silently discarded.

CLI Options for POD

Cisco Prime AR has options for the **query-sessions** and **release-sessions** CLI commands that enable querying or releasing sessions based on the session's age. Another option enables querying or releasing sessions based on any valid RADIUS attribute available in the user's session record. This section contains the following topics:

- [query-sessions](#)
- [release-sessions](#)

query-sessions

The syntax for using **query-sessions** *with-Age* option is the following:

```
query-sessions <path> with-Age <value>
```

Where <path> is the path to the server, session-manager or resource manager and <value> is the minimum age of the session specified in minutes or hours with options M, Minutes, H or Hours. This command returns all sessions that are older than the given age value.

The syntax for using **query-sessions** *with-Attribute* option is the following:

```
query-sessions <path> with-Attribute <name> <value>
```

Where <name> is the RADIUS attribute name and <value> is the value of the attribute to be matched. This command returns the sessions where a session record contains and matches the attribute value specified in <value> field.

release-sessions

The syntax for using **release-sessions** *with-Age* option is:

```
release-sessions <path> with-Age <value>
```

Where, <path> is the path to the server, session-manager or resource manager and <value> is the minimum age of the session specified in minutes or hours with options M for Minutes, H for Hours. This command returns all sessions that are older than the given age value.

The syntax for using **release-sessions** *with-Attribute* option is:

```
release-sessions <path> with-Attribute <name> <value>
```

Where, <name> is the RADIUS attribute name and <value> is the value of the attribute to be matched. This command returns the sessions where a session record contains and matches the attribute value specified in <value> field.

A new option is also available for **release-sessions** command to enable an administrator to trigger sending a POD for a user after the session is released.

```
release-sessions <path> with-<type> <value> [send-pod]
```

Where, <path> is the path to the server, Session Manager, or Resource Manager and <type> is one of the following: NAS, User, IP-Address ID, or Age. The **release-sessions** command with an optional [send-pod] at the end results in Cisco Prime AR sending a POD request. The PoD requests are directed to port number configured in /radius/clients/<client name>/DynamicAuthorizationServer/port. By default it is set to 3799. To configure udp xxx, set the port value as:

```
/radius/clients/<client name>/DynamicAuthorizationServer/port = xxx
```

Configuring Change of Authorization Requests

Cisco Prime AR supports Change of Authorization (CoA) requests as defined in Internet RFC 3576 that provides a way to change authorization status of users already logged on to the network. The CoA feature, also known as hot-lining, provides a wireless operator the ability to efficiently address issues with users that might otherwise be unauthorized to access packet data services. When a problem occurs that causes a user to be unauthorized to use the packet data service, a wireless operator can use the CoA feature to resolve the problem and return the user's packet data services.

When a user is hot-lined, their packet data service is redirected to a hot-line application that notifies the user of issues that might be blocking their access to normal packet data services. Hot-lining provides users with a way to address the issues blocking their access, such as billing issues, a prepaid account that has been depleted, or an expired credit card.

The CoA feature provides an option to the wireless operator administrator to send CoA packets to the client device when a user needs to be hot-lined. When to send a CoA request to a user depends on the wireless operator's site-specific policies.

Configuring the Client Object

You should enable CoA for each client object that might want to send CoA requests to those clients. You enable CoA in a client object using the `EnableDynamicAuthorization` property. This property is set to `FALSE` by default when you create a client object. The following example shows the default configuration for a new client object, `NAS1`.

```
[ //localhost/Radius/Clients/NAS1 ]
  Name = nas1
  Description =
  IPAddress =
  SharedSecret =
  Type = NAS
  Vendor =
  IncomingScript~ =
  OutgoingScript~ =
  EnableDynamicAuthorization = FALSE
```

If the Cisco Prime AR server might send a CoA request to this client, set the `EnableDynamicAuthorization` property to `TRUE`. When you set this property to `TRUE`, the Cisco Prime AR server creates a `DynamicAuthorizationServer` subdirectory under the client object. The following example shows a newly created `DynamicAuthorizationServer` subdirectory:

```
[ //localhost/Radius/Clients/NAS1/COA ]
  Port = 3799
  DynamicAuthSharedSecret =
  InitialTimeout = 5000
  MaxTries = 3
  PODataAttributeGroup =
  COAAttributeGroup =
```

The default port is 3799. You can change the port, if desired.

The property `DynamicAuthSharedSecret` is initially set to the same as value as the client's `SharedSecret` property when you set `EnableDynamicAuthorization` to `TRUE`. You can chose to configure a different secret for CoA in this subdirectory.

The `InitialTimeout` property represents the number of milliseconds used as a timeout for the first attempt to send a CoA packet to a remote server. For each successive retry on the same packet, the previous timeout value used is doubled. You must specify a number greater than zero, and the default value is 5000 (or 5 seconds).

The `MaxTries` property represents the number of times to send a proxy request to a remote server before deciding the server is offline. You must specify a number greater than zero, and the default is 3.

The `COAAttributeGroup` property points to a group of attributes to be included in a CoA request packet sent to this client.

You can create and configure the COAAttributeGroup in the **/Radius/Advanced/AttributeGroups/** directory. The default group is not set to any value by default. When an attribute group is configured, the Cisco Prime AR server includes the attributes in this group in a CoA request. The values for these attributes are fetched from the user's session record.

The CoA attribute group configuration can be used with a session-cache Resource Manager. For example, any new attributes that are to be sent in a CoA request can be configured for caching by the session-cache Resource Manager so they will be available in the session record when it is to be sent in the CoA request.

The CoA request might also contain AV pairs from the optional profile name in the **query-session** CLI command used to send the CoA request. In a 3GPP2 scenario, a profile containing the Filter-Id attribute set to a value "Hot-Line Active" can be included when a user is to be hot-lined. This can be used as a hot-line profile possibly containing other attributes as desired by the wireless operator. Another profile might be defined containing the Filter-Id attribute with the value "Hot-Line Normal." This profile can be used with the **query-session** CLI command to bring the user back to normal.

The CoA request packet sent by the Cisco Prime AR server conforms to internet RFC 3756. In response to a CoA request initiated by the Cisco Prime AR server, the client should respond with a COA-ACK if it is able to hot-line the user based on credentials available in the CoA request. If the client is unable to hot-line the user for any reason, the client can include an error-cause attribute with the appropriate reason in a COA-NAK packet.

The Cisco Prime AR server logs all CoA responses. If the Cisco Prime AR server does not receive a response to a CoA request within the timeout period, it will retransmit for the configured number of retries, then logs an error if no response is received.

The Cisco Prime AR server forwards proxied CoA requests sent by external servers to the destination NAS. The CoA requests are proxied based on the NAS-IP-Address in the incoming request. The proxied CoA requests from external servers are forwarded to the destination NAS only if the source IP address is configured to accept dynamic authorization requests. The responses received from the NAS (either COA-ACK or COA-NAK) are forwarded back to the source where the Cisco Prime AR server received the original proxy request.

Dynamic DNS

Cisco Prime AR supports the Dynamic DNS protocol providing the ability to update DNS servers. The dynamic DNS updates contain the hostname/IP Address mapping for sessions managed by Cisco Prime AR.

You enable dynamic DNS updates by creating and configuring new Resource Managers and new Remote Servers, both of type *dynamic-dns*. The dynamic-dns Resource Managers specify which zones to use for the forward and reverse zones and which Remote Servers to use for those zones. The dynamic-dns Remote Servers specify how to access the DNS Servers.

This section contains the following topics:

- [Configuring Dynamic DNS](#)
- [Testing Dynamic DNS with radclient](#)

Configuring Dynamic DNS

Before you configure Cisco Prime AR you need to gather information about your DNS environment. For a given Resource Manager you must decide which forward zone you will be updating for sessions the resource manager will manage. Given that forward zone, you must determine the IP address of the primary DNS server for that zone. If the dynamic DNS updates will be protected with TSIG keys, you must find out the name and the base64 encoded value of the secret for the TSIG key. If the resource manager should also update the reverse zone (ip address to host mapping) for sessions, you will also need to determine the same information about the primary DNS server for the reverse zone (IP address and TSIG key).

If using TSIG keys, use **aregcmd** to create and configure the keys. You should set the key in the Remote Server or the Resource Manager, but not both. Set the key on the Remote Server if you want to use the same key for all of the zones accessed through that Remote Server. Otherwise, set the key on the Resource Manager. That key will be used only for the zone specified in the Resource Manager.

Configuring the Dynamic DNS

To configure the dynamic-dns remote server:

Step 1 Launch **aregcmd**.

Step 2 Create the dynamic-dns TSIG Keys:

```
cd /Radius/Advanced/DDNS/TSIGKeys
add foo.com
```

This example named the TSIG Key, **foo.com**, which is related to name of the example DNS server we use. You should choose a name for TSIG keys that reflects the DDNS client-server pair (for example, **foo.bar** if the client is **foo** and the server is **bar**), but you should use the name of the TSIG Key as defined in the DNS server.

Step 3 Configure the TSIG Key:

```
cd foo.com
set Secret <base64-encoded string>
```

The Secret should be set to the same base64-encoded string as defined in the DNS server. If there is a second TSIG Key for the primary server of the reverse zone, follow these steps to add it, too.

Step 4 Use **aregcmd** to create and configure one or more dynamic-dns Remote Servers.

Step 5 Create the dynamic-dns remote server for the forward zone:

```
cd /Radius/RemoteServers
add ddns
```

This example named the remote server *ddns* which is the related to the remote server type. You can use any valid name for your remote server.

Step 6 Configure the dynamic-dns remote server:

```
cd ddns
set Protocol dynamic-dns
```

```
set IPAddress 10.10.10.1 (ip address of primary dns server for zone)
```

```
set ForwardZoneTSIGKey foo.com
```

```
set ReverseZoneTSIGKey foo.com
```

If the reverse zone will be updated and if the primary server for the reverse zone is different than the primary server for the forward zone, you will need to add another Remote Server. Follow the previous two steps to do so. Note that the IP Address and the TSIG Key will be different.

You can now use **aregcmd** to create and configure a resource manager of type dynamic-dns.

Step 7 Create the dynamic-dns resource manager:

```
cd /Radius/ResourceManagers
```

```
add ddns
```

This example named the service ddns which is the related to the resource manager type but you can use any valid name for your resource manager.

Step 8 Configure the dynamic-dns resource manager.

```
cd ddns
```

```
set Type dynamic-dns
```

```
set ForwardZone foo.com
```

```
set ForwardZoneServer DDNS
```

Finally, reference the new resource manager from a session manager. Assuming that the example configuration was installed, the following step will accomplish this. If you have a different session manager defined you can add it there if that is appropriate.

Step 9 Reference the resource manager from a session manager:

```
cd /Radius/SessionManagers/session-mgr-1/ResourceManagers
```

```
set 5 DDNS
```

**Note**

The Property AllowAccountingStartToCreateSession must be set to TRUE for dynamic DNS to work.

Step 10 Save the changes you have made.

Testing Dynamic DNS with radclient

After the Resource Manager has been defined it must be referenced from the appropriate Session Manager. You can use **radclient** to confirm that dynamic DNS has been properly configured and is operational.

Testing the Dynamic DNS using Radclient

To test Dynamic DNS using radclient:

Step 1 Launch **aregcmd** and set the trace to level 4.

```
aregcmd
```

Login to the Cisco Prime AR server as an administrative user.

```
trace 4
```

Step 2 Launch **radclient**.

```
cd /opt/CSCOar/bin
```

```
radclient
```

Step 3 Create an Accounting-Start packet

```
acct_request Start username
```

Example:

```
set p [ acct_request Start bob ]
```

Step 4 Add a Framed-IP-Address attribute to the Accounting-Start packet

Step 5 Send the Accounting-Start packet

```
$p send
```

Step 6 Check the **aregcmd** trace log and the dns server to verify that the host entry was updated in both the forward and reverse zones.

Dynamic Service Authorization Feature

Typically, Cisco Prime AR does not allow sending another Access-Request to the remote server after the user is connected to the LDAP servers for user authentication. The Dynamic Service Authorization feature allows you to access external databases such as LDAP and Oracle first to know which remote servers authenticated services need to be relayed. This feature enables Cisco Prime AR to determine whether to send access-accept back to the client or to send another access-request to the remote server such as LDAP and Oracle. Cisco Prime AR is able to perform this activity multiple times in a single access-request.

Configuring Dynamic Service Authorization Feature

Configuring the dynamic service authorization involves:

- [Setting up the Environment Variable](#)
- [Configuring the Script for the Dynamic Service Authorization](#)

Setting up the Environment Variable

Before configuring the dynamic service authorization feature, you must set the following three environment variables in Cisco Prime AR:

- **Re-Authentication-Service**

When the Re-Authentication-Service is set, the server directs the request to the specified reauthentication service for processing.

- **Re-Authorization-Service**

When the Re-Authorization-Service is set, the server directs the request to the specified reauthorization service for processing.

- **Re-Accounting-Service**

When the Re-Accounting-Service is set, the server directs the request to the specified reaccounting service for processing.

You can set the environmental variable by using scripts. See [Writing the Script, page 11-2](#) for more information.



Note

When using the same service for reauthentication and reauthorization, a loop can occur in these services. The loop count, by default is 10. You can change the loop count using the **Dynamic-Service-Loop-Limit** environment variable.

Following is a sample procedure for setting the environment variable:

```
proc dynamicservice { request response environ } {
$environ put Re-Authentication-Service "local-users"
$environ put Re-Authorization-Service "local-users"
}
```

You can append this procedure by copying it into **tclscript.tcl** that is located in **/opt/CSCOar/scripts/radius/tcl directory**, or to the location that you chose when you installed Cisco Prime AR. You can also use this procedure as a separate script file and configure the script accordingly. See [Adding the CheckEap.tcl Script, page 15-16](#) for more information on configuring the TCL script.

Configuring the Script for the Dynamic Service Authorization

To configure the script for the dynamic service authorization:

-
- Step 1** Launch **aregcmd**.
aregcmd
 - Step 2** Change directory to **/Radius/Scripts**.
cd /Radius/Scripts
 - Step 3** Enter **dynamicservice**.
 - Step 4** Change the directory to **dynamicservice**.
cd dynamicservice

You get the following output:

```
[ //localhost/Radius/Scripts/dynamicservice ]
Name = dynamicservice
Description =
Language =
```

Step 5 Set the Language property to TCL.

Set Language TCL

Step 6 Set the filename property to **tclscript.tcl**.

Set Filename tclscript.tcl

Step 7 Set the EntryPoint property to **dynamicservice**.

Set EntryPoint dynamicservice

The following is an example of the script configuration:

```
cd /Radius
set IncomingScript dynamicservice
[ //localhost/Radius ]
  IncomingScript~ = dynamicservice
  DefaultAuthenticationService~ = local-users
  DefaultAuthorizationService~ = local-users
```

Step 8 Enter **Save** to save the configuration.

The following shows a sample trace:

```
10/30/2012 12:32:02.258: P577: Packet received from 127.0.0.1
10/30/2012 12:32:02.259: P577: Packet successfully added
10/30/2012 12:32:02.259: P577: Trace of Access-Request packet
10/30/2012 12:32:02.259: P577:   identifier = 9
10/30/2012 12:32:02.259: P577:   length = 61
10/30/2012 12:32:02.259: P577:   reqauth =
b6:89:41:52:6e:d4:86:37:4a:aa:9b:27:1f:74:ff:05
10/30/2012 12:32:02.259: P577:   User-Name = bob
10/30/2012 12:32:02.259: P577:   User-Password =
2b:4a:f0:c8:95:f1:ad:e5:52:d4:83:0f:45:2b:2b:70
10/30/2012 12:32:02.259: P577:   NAS-Port = 2
10/30/2012 12:32:02.260: P577:   NAS-Identifier = localhost
10/30/2012 12:32:02.260: P577: Running Server's IncomingScript: dynamicservice
10/30/2012 12:32:02.261: P577:   Tcl: environ put Re-Authentication-Service local-users
-> OK
10/30/2012 12:32:02.261: P577:   Tcl: environ put Re-Authorization-Service local-users
-> OK
10/30/2012 12:32:02.261: P577: Using Client: localhost
10/30/2012 12:32:02.262: P577: Using NAS: localhost (127.0.0.1)
10/30/2012 12:32:02.262: P577: Request is directly from a NAS: TRUE
10/30/2012 12:32:02.262: P577: Authenticating and Authorizing with Service local-users
10/30/2012 12:32:02.262: P577: Getting User bob's UserRecord from UserList Default
10/30/2012 12:32:02.263: P577: user list user bob's password matches
10/30/2012 12:32:02.263: P577: Processing UserGroup PPP-users's check items
10/30/2012 12:32:02.263: P577: User bob is part of UserGroup PPP-users
10/30/2012 12:32:02.263: P577: Merging UserGroup PPP-users's BaseProfiles into response
dictionary
10/30/2012 12:32:02.264: P577: Merging BaseProfile default-PPP-users into response
dictionary
10/30/2012 12:32:02.264: P577: Merging attributes into the Response Dictionary:
10/30/2012 12:32:02.264: P577:   Adding attribute Service-Type, value = Framed
10/30/2012 12:32:02.264: P577:   Adding attribute Framed-Protocol, value = PPP
10/30/2012 12:32:02.264: P577:   Adding attribute Framed-Routing, value = None
10/30/2012 12:32:02.264: P577:   Adding attribute Framed-MTU, value = 1500
10/30/2012 12:32:02.264: P577:   Adding attribute Framed-Compression, value = VJ TCP/IP
header compression
10/30/2012 12:32:02.264: P577:   Adding attribute Ascend-Idle-Limit, value = 1800
10/30/2012 12:32:02.265: P577: Merging UserGroup PPP-users's Attributes into response
Dictionary
10/30/2012 12:32:02.265: P577: Merging attributes into the Response Dictionary:
10/30/2012 12:32:02.265: P577: Authenticating and Authorizing with Service local-users
```

```

10/30/2012 12:32:02.265: P577: Getting User bob's UserRecord from UserList Default
10/30/2012 12:32:02.266: P577: user list user bob's password matches
10/30/2012 12:32:02.266: P577: Processing UserGroup PPP-users's check items
10/30/2012 12:32:02.266: P577: User bob is part of UserGroup PPP-users
10/30/2012 12:32:02.266: P577: Merging UserGroup PPP-users's BaseProfiles into response
dictionary
10/30/2012 12:32:02.266: P577: Merging BaseProfile default-PPP-users into response
dictionary
10/30/2012 12:32:02.266: P577: Merging attributes into the Response Dictionary:
10/30/2012 12:32:02.266: P577:   Replacing attribute Service-Type, new value = Framed
10/30/2012 12:32:02.267: P577:   Replacing attribute Framed-Protocol, new value = PPP
10/30/2012 12:32:02.267: P577:   Replacing attribute Framed-Routing, new value = None
10/30/2012 12:32:02.267: P577:   Replacing attribute Framed-MTU, new value = 1500

```

Remote Session Management

Cisco Prime AR sessions can also be stored on a remote database. This improves the overall scalability of the number of sessions that Cisco Prime AR can simultaneously handle. The remote session manager internally uses two ODBC remote servers, Internal-ODBC-Read-Server and Internal-ODBC-Write-Server. Configurations pertaining to these internal remoteservers can be done under `/Radius/Advanced/RemoteODBCSessionServer`

For more information on how to configure the Remote ODBC Session Server, refer [“RemoteODBCSessionServer” section on page 4-70](#).



Note

Ensure that the length of fields such as Username, Session/Resource Manager name Session-Key, Query-Key and so on are limited to the value specified in the [Table 17-8](#) while it is configured. Although the field length of entire session record is 3KB it is limited to 2KB. This is practically sufficient to hold all the session parameters as well as the cached attributes (if any).

Table 17-8 **Schema Details**

Field	Type
ID	NUMBER(10)
SESSION_KEY	VARCHAR2(20)
NAME	VARCHAR2(20)
PER_USER_RM	VARCHAR2(20)
PER_GROUP_RM	VARCHAR2(20)
IP_RM	VARCHAR2(20)
IP	VARCHAR2(20)
SESSION_MANAGER	VARCHAR2(20)
AC	NUMBER(10)
NAS	VARCHAR2(20)
CACHE_RM	VARCHAR2(20)
Q_VALUE	VARCHAR2(20)

Table 17-8 Schema Details (continued)

Field	Type
TS	NUMBER(15)
SESSION_RECORD	VARCHAR2(3072)

**Note**

Remote session manager will work only with Oracle database.

**Note**

In remote-session-manager, query-session with the 'with-age' option will not work.

Wx Interface Support for SubscriberDB Lookup

Cisco Prime AR supports Diameter Wx interface to fetch the authentication vectors from HSS required for EAP-SIM/EAP-AKA authentication.

The EAP-SIM and EAP-AKA authentication service is extended to generate a Diameter message Multimedia-Authentication-Request (MAR), with the subscriber identity(IMSI), to the HSS when it requires the authentication vectors. The HSS sends a Diameter Multimedia-Authentication-Answer (MAA) back containing the number of triplets/quintuplets.

The PreRequestTranslationScript, PostRequestTranslationScript, PreResponseTranslationScript, and PostResponseTranslationScript are the available scripting points to modify the RADIUS and Diameter packets while sending and receiving the packets to or from the HSS. For more information, see [Table 9-1](#) for EAP-AKA and [Table 10-6](#) for EAP-SIM details.

Figure 17-1 Wx Interface Support for SubscriberDB lookup

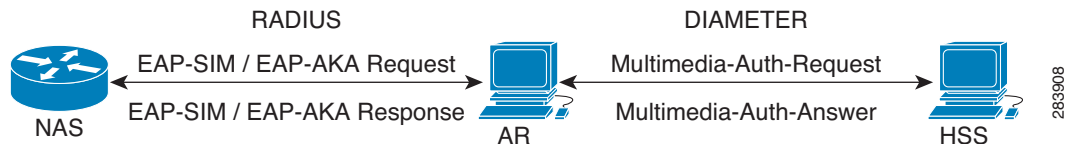

For more information on Wx interface, see the [3GPP TS 29.124](#) and [TS 29.229](#) specifications.

Configuration Examples

The following shows an example configuration for EAP-AKA:

```
[ //localhost/Radius/Services/eap-aka-wx ]
  Name = eap-aka-wx
  Description =
  Type = eap-aka
  AlwaysRequestIdentity = False
  EnableIdentityPrivacy = False
  PseudonymSecret = <encrypted>
```



```
PseudonymRenewtime = "24 Hours"  
PseudonymLifetime = Forever  
Generate3GPPCompliantPseudonym = False  
EnableReauthentication = False  
MaximumReauthentications = 16  
ReauthenticationTimeout = 3600  
ReauthenticationRealm =  
AuthenticationTimeout = 120  
QuintetGenerationScript~ =  
UseProtectedResults = False  
SendReAuthIDInAccept = False  
SubscriberDBLookup = Diameter  
DestinationRealm = mpc.com  
PreRequestTranslationScript~ =  
PostRequestTranslationScript~ =  
PreResponseTranslationScript~ =  
PostResponseTranslationScript~ =
```

The following shows an example configuration for EAP-SIM:

```
[ //localhost/Radius/Services/eap-sim-wx ]  
Name = eap-sim-wx  
Description =  
Type = eap-sim  
NumberOfTriplets = 2  
UseSimDemoTriplets = False  
AlwaysRequestIdentity = False  
EnableIdentityPrivacy = False  
PseudonymSecret = <encrypted>  
PseudonymRenewtime = "24 Hours"  
PseudonymLifetime = Forever  
Generate3GPPCompliantPseudonym = False  
EnableReauthentication = False  
MaximumReauthentications = 16  
ReauthenticationTimeout = 3600  
ReauthenticationRealm =  
TripletCacheTimeout = 120  
AuthenticationTimeout = 120  
UseProtectedResults = False  
SendReAuthIDInAccept = False  
SubscriberDBLookup = Diameter  
DestinationRealm = hss.com  
PreRequestTranslationScript~ =  
PostRequestTranslationScript~ =  
PreResponseTranslationScript~ =  
PostResponseTranslationScript~ =
```

Smart Grid Solution Management

Cisco Prime AR provides identity and access management for the smart grid solutions on IPv6 (and IPv4) networks. This is achieved using the Elliptic Curve Cryptographic (ECC) based certificate validation and SNMP support for TACACS+.

For EAP services, in addition to RSA certificates, Cisco Prime AR supports verification of ECC certificates. ECC uses elliptic curves to encrypt data when creating keys which enables you to create shorter and stronger keys for better efficiency. This is achieved using the Cisco SSL library APIs.

TACACS+ supports ASCII, PAP, and CHAP Authentication type, login and enable services, and LDAP, OCI, and ODBC services in addition to Local service.

The client certificate files and RSA or ECC key file are available in `/cisco-ar/pki` as **client-cert.pem** and **client-key.pem** respectively. Both the files must be in “.PEM” format, since the certificate validation is done based on the extension of the files.

ECC certificate validation is used in the following authentication methods:

- [EAP-FAST](#)
- [EAP-Transport Level Security \(TLS\)](#)
- [EAP-TTLS](#)
- [Protected EAP](#)

TACACS+ Support for AA

TACACS+ (Terminal Access Controller Access-Control System Plus) is a terminal access control protocol for routers, switches, network access servers and other networked computing devices. The main goal of TACACS+ is to provide separate authentication, authorization and accounting services. However, Cisco Prime AR supports authentication and command accounting services in this release.

In Cisco Prime AR, TACACS+ provides authentication for login services with PAP, CHAP, and ASCII authentication types. It also tracks and maintains the executed command details in the command accounting. Configuration is supported through the CLI/GUI and statistics are provided through CLI, GUI, and SNMP. TACACS+ supports the following Cisco Prime AR services:

- Local-users and Local-file service
- OCI
- ODBC
- LDAP

Configuration Example

The following shows an example configuration for TACACS+:

```
[ /Radius/Clients/mytac ]
  Name = mytac
  Description =
  Protocol = tacacs-and-radius
  IPAddress = 10.77.123.57
  SharedSecret = <encrypted>
  Type = NAS
  Vendor =
  IncomingScript~ =
  OutgoingScript~ =
  EnableDynamicAuthorization = FALSE
  NetMask =
  EnableNotifications = FALSE
  EnforceTrafficThrottling = TRUE
```



CHAPTER 18

Directing RADIUS Requests

You can use the policy engine to determine the AAA services for processing a request packet based on the User-Name suffix, User-Name prefix, Calling-Station-ID, Called-Station-ID and Nas-IP-Address. You configure the policy Engine through policies and rules.

This chapter contains the following sections:

- [Configuring Policies and Rules](#)
- [Routing Requests](#)
- [Standard Scripts Used with Rules](#)

Configuring Policies and Rules

A policy is a group of rules. Each rule consists of a set of conditions and corresponding services. A rule succeeds if all the conditions specified in the rule are satisfied. If a rule succeeds, the services indicated by its service attributes are used to process the packet. However, Cisco Prime AR defers packet processing until the policy succeeds.

This section contains the following topics:

- [Configuring Policies](#)
- [Configuring Rules](#)
- [Wildcard Support](#)
- [Script and Attribute Requirements](#)
- [Validation](#)
- [Known Anomalies](#)

Configuring Policies

You configure policies under **/Radius/Policies**. To enable the Cisco Prime AR server to use policies, you must first configure policy named SelectPolicy.

```
[ //localhost/Radius/Policies/SelectPolicy ]
  Name = SelectPolicy
  Description =
  Grouping = rule1|rule2
```

The Grouping property of a policy determines which rules are to be evaluated and in which order. Rules are evaluated from left to right. Use the pipe (|) or ampersand (&) character to group rules.

**Note**

Before you can provide rules in the Grouping property, the rules must first be added to the configuration under **/Radius/Rules**.

The following are the Grouping property rules:

- If rules are grouped with the pipe character (`rule1|rule2`), all rules in the group are evaluated in sequential order until one of the rules succeeds. If any one of the rules in the policy succeeds, the policy succeeds.
- If rules are grouped with the ampersand character (`rule1&rule2&rule3`), all the rules listed are evaluated until one of the rules fails. For the policy to succeed, all the rules in the policy must succeed.

Configuring Rules

You configure rules under **/Radius/Rules**. When you add a rule, provide the script that should be executed for the rule and the attributes to use if the rule succeeds. The script you specify must be defined under **/Radius/Scripts**, as shown in the following:

```
[ //localhost/Radius/Rules/rule1 ]
  Name = rule1
  Description =
  Script~ =
  Attributes/
    Authentication-service = local-users
    Authorization-service = local-users
    Realm = @cisco.com

[ //localhost/Radius/Scripts/ExecRealmRule ]
  Name = ExecRealmRule
  Description =
  Language = Rex
  Filename = librexscript.so
  EntryPoint = ExecRealmRule
  InitEntryPoint =
  InitEntryPointArgs =
```

Wildcard Support

Cisco Prime AR supports limited wildcard functionality in rules for Realm, DNIS, and CLID attributes, specifically the asterisk (*) and question mark (?) characters. The asterisk matches any number of characters, including the null character. The question mark matches any single character, not including the null character. Cisco Prime AR also supports both wildcard characters in one pattern, as in `CLID = 180098?87*`.

**Note**

The realms should start with either the @ or # character. For example, `Realm=@cisco.com`.

- For an exact matching of the realm, you should configure the rule with the exact realm. For example, for an exact match to `abc@cisco.com`, you should use `Realm=@cisco.com`.

- If you use Realm=cisco.com (without any valid character), values such as xyz@us.cisco.com, xyz@uk.cisco.com, abc#cisco.com, and so on can also match and return a success.

The following is an example using the asterisk wildcard character used in a Rule named *rule1*:

```
[ //localhost/Radius/Rules/rule1 ]
  Name=rule1
  Description =
  ScriptName = ExecRealmRule
  Attributes/
    Authentication-Service = Local-Users
    Authorization-Service = Local-Users
    Realm = ~/@*cisco.com/
```

Rule *rule1* succeeds when the domain of the username in an access request matches the *@*cisco.com* pattern. Each of the following is a good match: *@us.cisco.com*, *@eng.cisco.com*, and *@cisco.com*. With a match, the **ExecRealmRule** script sets Authentication-Service and Authorization-Service to Local-Users in the environment dictionary.

The following is an example using the "?" wildcard character in a Rule named *rule2*:

```
[ //localhost/Radius/Rules/rule2 ]
  Name = rule2
  Description =
  ScriptName = ExecDNISRule
  Attributes/
    Authentication-Service = Translation-Service
    Authorization-Service = Translation-Service
    DNIS = 1800345987?
```

Rule *rule2* succeeds if the Called-Station-Id attribute (DNIS) in the packet matches 1800345987?. Each of the following is a good match: 18003459876 and 18003459870, while 1800345987 is not. With a match, the **ExecDNISRule** script sets Authentication-Service and Authorization-Service to Translation-Service in the environment dictionary.

Script and Attribute Requirements

The following script and attribute requirements exist:

- **/Radius/Policies/SelectPolicy** is the first policy Cisco Prime AR applies.
- The characters "|" and "&" are reserved as logical operands in a Grouping definition; they cannot be included in a **/Radius/Rules** name.
- A space is not permitted between the logical operands and the rules in a Grouping definition.
- The scripts included in the rules must be defined under the **/Radius/Scripts** directory.
- The attributes included in the rules must be defined under the **/Radius/Advanced/Attribute Dictionary** directory.
- The rules included in the policies must be defined under the **/Radius/Rules** directory.

Validation

When policies are configured, Cisco Prime AR performs the following validations:

- Ensures the scripts included in the rules are defined under the **/Radius/Scripts** directory.
- Ensures the attributes included in the rules are defined under the **/Radius/Advanced/Attribute Dictionary** directory.
- Ensures the rules included in the policies are defined under the **/Radius/Rule** directory.

Known Anomalies

The following anomalies currently exist:

- Grouping expressions are not checked for validity.
- The use of parentheses to denote precedence is not supported in a Grouping definition.
- A check is not performed to determine whether a policy that is included within another policy is defined under the **/Radius/Policies** directory.

Routing Requests

Using the policy engine, Cisco Prime AR enables you to route requests based on attributes in access request packets. The following sections describe how to route requests based on different attributes:

- [Routing Requests Based on Realm](#)
- [Routing Requests Based on DNIS](#)
- [Routing Requests Based on CLID](#)
- [Routing Requests Based on NASIP](#)
- [Routing Requests Based on User-Name Prefix](#)
- [Attribute Translation](#)
- [Time of Day Access Restrictions](#)

Routing Requests Based on Realm

The Cisco Prime AR policy engine can process request packets based on the realm in the User-Name attribute.

In the following example, request packets with the User-Name attribute containing *@abc.com* as the suffix should be processed locally and the request packets with User-Name attribute containing *@xyz.com* should be proxied to a remote AAA Server.

```
[ //localhost/Radius/Policies ]
  SelectPolicy/
    Name = SelectPolicy
    Description =
    Grouping = abcrule|xyzrule
```

The following SelectPolicy refers to two rules *abcrule* and *xyzrule*:

1. When a request packet arrives, Cisco Prime AR executes SelectPolicy beginning with *abcrule* to determine if the User-Name attribute contains *@abc.com* as the realm. If so, the *abcrule* is successful as is SelectPolicy, therefore the packet is processed locally.
2. If the User-Name attribute does not contain *@abc.com* as the realm, Cisco Prime AR executes *xyzrule* to determine if the User-Name attribute contains *@xyz.com*. If so, *xyzrule* is successful as is SelectPolicy. Hence the request is proxied to the remote server specified in *xyz-service*.

In this example, the rules are grouped using the | (or) operator. So all the rules specified in the grouping parameter will be executed until one of them succeeds.

```
[ //localhost/Radius/Rules ]
  abcrule/
    Name = abcrule
    Description =
    Script~ = ExecRealmRule
    Attributes/
      Authentication-Service = local-users
      Authorization-Service = local-users
      Realm = @abc.com

  xyzrule/
    Name = xyzrule
    Description =
    Script~ = ExecRealmRule
    Attributes/
      Authentication-Service = xyz-service
      Authorization-Service = xyz-service
      Realm = @xyz.com
```

The ExecRealmRule script matches the realm with the suffix in the User-Name attribute and sets the appropriate service for processing the packet. This is a standard script available with Cisco Prime AR. Cisco Prime AR can also be configured to set a particular kind of service for multiple realms. For example, the following configuration can be used if packets with *@pqr.com* or *@klm.com* should be processed using the same service *klm-service*.

```
[ //localhost/Radius/Rules ]
  rulex/
    Name = rulex
    Description =
    Script~ = ExecRealmRule
    Attributes/
      Authentication-Service = klm-service
      Authorization-Service = klm-service
      Realm = "@pqr.com" "@klm.com"
```

Routing Requests Based on DNIS

The Cisco Prime AR policy engine can process request packets differently based on the DNIS (Called-Station-Id) attribute in the request packet.

In the following example, request packets with the Calling-Station-Id attribute that contain 1111111 should be processed by *abc-service*, while request packets with the Called-Station-Id attribute that contain 2222222 or 3333333 should be processed using *xyz-service*.

```
[ //localhost/Radius/Policies ]
  SelectPolicy/
    Name = SelectPolicy
```

```
Description =
Grouping = abcrule|xyzrule
```

The following SelectPolicy refers to two rules, *abcrule* and *xyzrule*:

1. When a request packet arrives, Cisco Prime AR executes SelectPolicy beginning with *abcrule* to determine if the DNIS attribute contains 1111111. If so, the *abcrule* is successful as is SelectPolicy, and the packet is processed using *abc-service*.
2. If the Called-Station-Id attribute does not contain 1111111, Cisco Prime AR executes the *xyzrule* to determine if the Called-Station-Id attribute contains 2222222 or 3333333. If so, *xyzrule* is successful as is SelectPolicy, and the packet is processed using *xyz-service*.

```
[ //localhost/Radius/Rules ]
  abcrule/
    Name = abcrule
    Description =
    Script~ = ExecDNISRule
    Attributes/
      Authentication-Service = abc-service
      Authorization-Service = abc-service
      DNIS = 1111111

  xyzrule/
    Name = xyzrule
    Description =
    Script~ = ExecDNISRule
    Attributes/
      Authentication-Service = xyz-service
      Authorization-Service = xyz-service
      DNIS = "2222222" "3333333"
```

The **ExecDNISRule** script matches the DNIS value configured in Cisco Prime AR with the value in the Called-Station-Id attribute of the request packet and sets the appropriate service for processing the packet. **ExecDNISRule** is a standard script available with Cisco Prime AR.

Routing Requests Based on CLID

The Cisco Prime AR policy engine can process request packets differently based on the CLID value in arriving request packets.

In the following example, the request packets with a Calling-Station-Id (CLID) attribute value of 1111111 should be processed by *abc-service* and the request packets with the CLID attribute value of 2222222 or 3333333 should be processed using *xyz-service*.

```
[ //localhost/Radius/Policies ]
  SelectPolicy/
    Name = SelectPolicy
    Description =
    Grouping = abcrule|xyzrule
```

The following SelectPolicy refers to two rules, *abcrule* and *xyzrule*:

1. When a request packet arrives, Cisco Prime AR executes SelectPolicy beginning with *abcrule* to determine if the CLID attribute contains 1111111. If so, the *abcrule* is successful as is SelectPolicy, and the packet is processed using *abc-service*.
2. If the CLID attribute does not contain 1111111, Cisco Prime AR executes *xyzrule* to determine if the CLID attribute contains 2222222 or 3333333. If so, *xyzrule* is successful and hence SelectPolicy becomes successful and the packet is processed using *xyz-service*.

```
[ //localhost/Radius/Rules ]
  abcrule/
    Name = abcrule
    Description =
    Script~ = ExecCLIDRule
    Attributes/
      Authentication-Service = abc-service
      Authorization-Service = abc-service
      CLID = 1111111

  xyzrule/
    Name = xyzrule
    Description =
    Script~ = ExecCLIDRule
    Attributes/
      Authentication-Service = xyz-service
      Authorization-Service = xyz-service
      CLID = "2222222" "3333333"
```

The **ExecCLIDRule** script matches the CLID value configured in Cisco Prime AR with the value in the CLID attribute of the request packet and sets the appropriate service for processing the packet. **ExecCLIDRule** is a standard script available with Cisco Prime AR.

Routing Requests Based on NASIP

The Cisco Prime AR policy engine can process request packets differently based on the client IP address value in arriving request packets.

In the following example, arriving request packets with the NAS-IP-Address attribute value 1.1.1.1 should be processed by abc-service and arriving request packets with the NAS-IP-Address attribute value 2.2.2.2 should be processed using xyz-service.

```
[ //localhost/Radius/Policies ]
  SelectPolicy/
    Name = SelectPolicy
    Description =
    Grouping = abcrule|xyzrule
```

The following SelectPolicy refers to two rules, *abcrule* and *xyzrule*:

1. When a request packet arrives, Cisco Prime AR executes SelectPolicy beginning with abcrule to determine if the NAS-IP-Address attribute contains an IP address from the subnet 1.1.1.0/24. If so, the abcrule is successful as is SelectPolicy, and the packet is processed using abc-service.
2. If the NAS-IP-Address attribute does not contain an IP address from the subnet 1.1.1.0/24, Cisco Prime AR executes xyzrule to determine if the NAS-IP-Address attribute contains 2.2.2.2. If so, xyzrule is successful as is SelectPolicy, and the packet is processed using xyz-service.

```
[ //localhost/Radius/Rules ]s
  abcrule/
    Name = abcrule
    Description =
    Script~ = ExecNASIPRule
    Attributes/
      Authentication-Service = abc-service
      Authorization-Service = abc-service
      Client-IP-Address = 1.1.1.0
      Subnet-mask = 255.255.255.0

  xyzrule/
    Name = xyzrule
```

```

Description =
Script~ = ExecNASIPRule
Attributes/
  Authentication-Service = xyz-service
  Authorization-Service = xyz-service
  Client-IP-Address = 2.2.2.2

```

The **ExecNASIPRule** script matches the Client IP address configured in Cisco Prime AR with the value in the NAS-IP-Address attribute of the request packet and sets the appropriate service for processing the packet. **ExecNASIPRule** is a standard script available with Cisco Prime AR.

Routing Requests Based on User-Name Prefix

You can use the Cisco Prime AR policy engine to select a service based on the prefix in the User-Name attribute.

In the following example, request packets with a User-Name attribute that contains @abc.com as the suffix and cisco as the prefix should be processed using the service abc-service. A request packet with User-Name attribute containing cisco/bob@abc.com will be processed using abc-service.

```

[ //localhost/Radius/Policies ]
  SelectPolicy/
    Name = SelectPolicy
    Description =
    Grouping = suffixrule & prefixrule

```

The following SelectPolicy refers to two rules, *suffixrule* and *prefixrule*:

1. When a request packet arrives, Cisco Prime AR executes SelectPolicy beginning with suffixrule to determine if the realm in the User-Name attribute contains @abc.com. If so, the suffixrule is successful. Since there is an “&” operator between the rules, the prefixrule must also succeed for the SelectPolicy to be successful.
2. The prefixrule is now processed to determine if the prefix in the User-Name attribute contains cisco. If so, the prefixrule is successful which makes SelectPolicy successful, and the AA service is set to the service specified in the prefixrule.

```

[ //localhost/Radius/Rules ]
  abcrule/
    Name = suffixrule
    Description =
    Script~ = ExecRealmRule
    Attributes/
      Realm = @abc.com

  prefixrule/
    Name = prefixrule
    Description =
    Script~ = ExecPrefixRule
    Attributes/
      Authentication-Service = abc-service
      Authorization-Service = abc-service
      Delimiters = @##&/
      Prefix = cisco
      StripPrefix = No

```

ExecPrefixRule script matches the prefix configured in Cisco Prime AR with the prefix in the User-Name attribute of the request packet and sets the appropriate service for processing the packet. **ExecPrefixRule** is a standard script available with Cisco Prime AR. See [ExecPrefixRule](#) for more information.

Attribute Translation

The attribute translation feature supports the RADIUS proxy enabling you to customize attribute filters so that RADIUS attribute value (AV) pairs can be inserted, deleted, or substituted.

For example, when a request is proxied from AAA Server on ISP A to AAA Server on ISP B, some AV pairs might be substituted (such as IP address) because they might not be valid on the ISP B network. Additionally, ISP B might return some vendor-specific attributes (VSAs) that are not applicable to ISP A's network. Therefore, ISP A will substitute ISP B's VSA value pairs for ISP A's VSAs.

Two configuration points under the **/Radius** directory support this feature,

- [Translations](#)
- [TranslationGroups](#)
- [Parsing Translation Groups](#)

Translations

Under the **/Radius/Translations** directory, any translation to insert, substitute, or translate attributes can be added. The following is a sample configuration under the **/Radius/Translations** directory:

```
[ //localhost/Radius/Translations/T1 ]
  Name = T1
  Description =
  DeleteAttrs = Session-Timeout,Called-station-id
  Attributes/
    Calling-Station-id = 1232909
```

DeleteAttrs is the set of attributes to be deleted from the packet. Each attribute is comma separated and no spaces are allowed between attributes.

Under the **/Radius/Translations/T1/Attributes** directory, the attributes that should be inserted and the attributes that should be substituted are specified. These AV pairs are either added to the packet if not present already or replaced with the configured value.

TranslationGroups

Under the **/Radius/TranslationGroups** directory, translations can be grouped and applied to certain sets of packets, which are referred to in a rule.

The following is a sample configuration under the **/Radius/TranslationGroups** directory:

```
[ //localhost/Radius/TranslationGroups/CiscoIncoming ]
  Name = CiscoIncoming
  Description =
  Translations/
    1. T1
```

The translation group is referenced through the Cisco Prime AR policy engine in the **/Radius/Rules/<RuleName>/Attributes** directory.

- Incoming-Translation-Groups are set to a translation group (for example CiscoIncoming).
- Outgoing-Translation-Groups are to set to another translation group (for example CiscoOutgoing).

The following is an example of setting up a rule for a translation group.

```
[ //localhost/Radius/Rules/ciscotranslationrule ]
  Name = ciscotranslationrule
  Description =
```

```
Script~ = ParseTranslationGroupsByRealm
Attributes/
  Incoming-Translation-Groups = CiscoIncoming
  Outgoing-Translation-Groups = CiscoOutgoing
  Realm = @cisco.com
```

The `ciscoTranslationRule` rule must be referred to in the `/Radius/Policies` directory, so the Cisco Prime AR policy engine can invoke this rule. If the pattern of Realm, DNIS, or CLID matches the one defined in the rule, Cisco Prime AR sets the environment variable `Incoming-Translation-Groups` to `CiscoIncoming`. By looking up the definition of `CiscoIncoming`, Cisco Prime AR applies all of the translations to the incoming packet (before it is proxied to the other server).

When the proxied packet comes back to the RADIUS server, Cisco Prime AR sets the environment variable, `Outgoing-Translation-Groups` to `CiscoOutgoing`.

DNIS, CLID, and Realm are supported for filtering packets. Cisco Prime AR provides the following scripts to facilitate filtering based on DNIS, CLID and Realm.

Parsing Translation Groups

Cisco Prime AR provides three scripts that enable you to parse translation groups based on the DNIS, CLID or Realm attribute in an incoming packet. These scripts are:

- `ParseTranslationGroupsByDNIS`
- `ParseTranslationGroupsByCLID`
- `ParseTranslationGroupsByRealm`

In the following example, request packets containing `@abc.com` as the realm should be proxied to the remote server defined under `abc-service`. Before redirecting the request packet to the remote server, the `Calling-Station-Id` of the packet should be changed to 111.

```
[ //localhost/Radius/Policies ]
  SelectPolicy/
    Name = SelectPolicy
    Description =
    Grouping = realmrule & translaterule
```

The following `SelectPolicy` refers to two rules, `realmrule` and `translaterule`:

1. When a request packet arrives, Cisco Prime AR executes `SelectPolicy` beginning with “`realmrule`” to determine if the realm in the `User-Name` attribute contains 1.1.1.1. If so, the `realmrule` is successful and the AA service is set to `abc-service`.
2. Next Cisco Prime AR executes the `translaterule` to change the CLID of the packet to 111.

```
[ //localhost/Radius/Rules/ciscotranslationrule ]
  Name = ciscotranslationrule
  Description =
  Script~ = ParseTranslationGroupsByRealm
  Attributes/
    Incoming-Translation-Groups = CiscoIncoming
    Realm = @cisco.com

[ //localhost/Radius/Translations ]
  Entries 1 to 1 from 1 total entries
  Current filter: <all>
  T1/
    Name = T1
    Description =
    Attributes/
      calling-station-id = 111
```

```
[ //localhost/Radius/TranslationGroups ]
  Entries 1 to 1 from 1 total entries
  Current filter: <all>
  CiscoIncoming/
    Name = CiscoIncoming
    Description =
  Translations/
    1. T1
```

Time of Day Access Restrictions

You can use the Cisco Prime AR policy engine to implement access restriction on users based on the time of day. The following are **ExecTimeRule** script that implements this functionality:

- **ExecTimeRule** can be used to check the time at which the request packet arrives and determine if access should be granted based on the authorization parameters for the user.
- If the rule succeeds, **ExecTimeRule** sets the Acceptedprofiles Environment dictionary variable to a profile or a set of profiles, as in the following:

```
Acceptedprofiles=Regularaccess::Highprivilegeaccess
```



Note

If more than one profile is to be added to the Acceptedprofiles variable, use two colons to separate them (::).

If the user is authenticated, the Baseprofile of the user is compared with the Acceptedprofiles. All the profiles that are in the Baseprofile and in Acceptedprofiles will be used as profiles while sending the response for the user.

For example, consider the following user configuration of user1:

```
[ //localhost/Radius/UserLists/new/user1 ]
  Name = user1
  Description =
  Password = <encrypted>
  AllowNullPassword = FALSE
  Enabled = TRUE
  Group~ = regularusers
  BaseProfile~ =highprivilegeaccess::readonlyaccess::regularaccess
  AuthenticationScript~ =
  AuthorizationScript~ =
  UserDefined1 =
  Attributes/
  CheckItems/
```

The Baseprofile of the user1 has highprivilegeaccess, readonlyaccess and regularaccess. If the Acceptedprofiles of the user has regularaccess and highprivilegeaccess, the profiles regularaccess and highprivilegeaccess will be used while sending the response packet.

This section contains the following topics:

- [Setting Time Ranges in ExecTimeRule](#)
- [ExecTimeRule Example Configuration](#)
- [Reducing Overhead Using Policies to Group Rules](#)
- [ParseTranslationGroupsByDNIS](#)

Setting Time Ranges in ExecTimeRule

ExecTimeRule accepts time range in the following format.

Set timerange “* * * * *”

The first star indicates minutes and can be a value from 0-59. The second star indicates hours and can be a value from 0-23. The third star indicates day of the month and can be a value from 1-31. The fourth star indicates month and can be a value from 1-12. The fifth star indicates day of the week and can be a value from 0-6 where 0 indicates Sunday, 1 indicates Monday, and so on.

For example, to schedule a particular action to occur every Sunday during the month of December, use a command line like this:

Set timerange “* * * * 12 0”

ExecTimeRule Example Configuration

This section provides a configuration example where a user, user1, is only authorized for PPP service between 10 AM and 6 PM. If a login occurs at any other time, user1 will be authorized only for telnet service.

Policies

```
[ //localhost/Radius/Policies ]
  Entries 1 to 1 from 1 total entries
  Current filter: <all>
  SelectPolicy/
    Name = SelectPolicy
    Description =
    Grouping = ppprule|telnetrule
```

Rules

```
[ //localhost/Radius/Rules ]
  Entries 1 to 2 from 2 total entries
  Current filter: <all>
  ppprule/
    Name = ppprule
    Description =
    Script~ = ExecTimeRule
    Attributes/
      acceptedprofiles = default-ppp-users
      timerange = "* 10-18 * * * "
  telnetrule/
    Name = telnetrule
    Description =
    Script~ = ExecTimeRule
    Attributes/
      acceptedprofiles = default-telnet-users
      timerange = "* 0-10,18-23 * * * "
```

Profiles

```
[ //localhost/Radius/Profiles ]
  Entries 1 to 5 from 5 total entries
```



```

Current filter: <all>
default-PPP-users/
  Name = default-PPP-users
  Description =
  Attributes/
    Ascend-Idle-Limit = 1800
    Framed-Compression = "VJ TCP/IP header compression"
    Framed-MTU = 1500
    Framed-Protocol = PPP
    Framed-Routing = None
    Service-Type = Framed
default-Telnet-users/
  Name = default-Telnet-users
  Description =
  Attributes/
    Login-IP-Host = 204.253.96.3
    Login-Service = Telnet
    Login-TCP-Port = 541

```

User

```

[ //localhost/Radius/UserLists/new/user1 ]
  Name = user1
  Description =
  Password = <encrypted>
  AllowNullPassword = FALSE
  Enabled = TRUE
  Group~ = regularusers
  BaseProfile~ = default-telnet-users::default-ppp-users
  AuthenticationScript~ =
  AuthorizationScript~ =
  UserDefined1 =
  Attributes/
  CheckItems/

```

Reducing Overhead Using Policies to Group Rules

When you configure a large number of rules, the processing of request packets can be slow. For example, if you have 50 rules and only the last rule succeeds, the Cisco Prime AR server will have to check the preceding 49 rules before executing the rule that succeeds. You can reduce this overhead by using policies to group rules.

The following sample configuration, Cisco Prime AR must choose the AA service to be used for two domains, abc.com and xyz.com, based on the DNIS. You can do this by configuring different policies for different domains.

Policies

In the following configuration, SelectPolicy selects the policy to process packets with realm abc.com or xyz.com. Based on the realm that arrives in the request packet, abcrealmrule and xyzrealmrule decide whether to use abc-policy or xyz-policy to process the packets. abc-policy and xyz-policy are configured with rules to check for DNIS numbers in the respective domains and set the AA services appropriately.

```

[ //localhost/Radius/Policies ]
  Entries 1 to 3 from 3 total entries
  Current filter: <all>
  SelectPolicy/
    Name = selectpolicy

```

```

        Description =
        Grouping = abcrealmrule|xyzrealmrule
abc-policy/
    Name = abc-policy
    Description =
    Grouping = abcDNISrule1|abcDNISrule2
xyz-policy/
    Name = xyz-policy
    Description =
    Grouping = xyzDNISrule1|xyzDNISrule2

```

Rules

```

[ //localhost/Radius/Rules ]
Entries 1 to 6 from 6 total entries
Current filter: <all>

abcrealmrule/
    Name = abcrealmrule
    Description =
    Script~ = ExecRealmRule
    Attributes/
        policy = abc-policy
        realm = @abc.com
xyzrealmrule/
    Name = xyzrealmrule
    Description =
    Script~ = ExecRealmRule
    Attributes/
        policy = xyz-policy
        realm = @xyz.com
abcDNISrule1/
    Name = abcDNISrule1
    Description =
    Script~ = ExecDNISRule
    Attributes/
        Authentication-Service = abc1-service
        Authorization-Service = abc1-service
        DNIS = 1111111
abcDNISrule2/
    Name = abcDNISrule2
    Description =
    Script~ = ExecRealmRule
    Attributes/
        Authentication-Service = abc2-service
        Authorization-Service = abc2-service
        DNIS = 2222222
xyzDNISrule1/
    Name = xyzDNISrule1
    Description =
    Script~ = ExecRealmRule
    Attributes/
        Authentication-Service = xyz1-service
        Authorization-Service = xyz2-service
        DNIS = 6666666
xyzDNISrule2/
    Name = xyzDNISrule2
    Description =
    Script~ = ExecRealmRule
    Attributes/
        Authentication-Service = xyz2-service
        Authorization-Service = xyz2-service

```

```
DNIS = 7777777
```

Standard Scripts Used with Rules

Cisco Prime AR software includes the following scripts that you can use with the rules:

- [ExecRealmRule](#)
- [ExecDNISRule](#)
- [ExecCLIDRule](#)
- [ExecNASIPRule](#)
- [ExecPrefixRule](#)
- [ExecSuffixRule](#)
- [ExecTimeRule](#)
- [ParseTranslationGroupsByRealm](#)
- [ParseTranslationGroupsByDNIS](#)
- [ParseTranslationGroupsByCLID](#)

ExecRealmRule

Use the **ExecRealmRule** script to determine the Authentication service and Authorization service to be used to process the request packet based on the suffix (Realm) in the User-Name attribute. You configure the Realm for which the packet should be checked and the service to use in the Attributes subdirectory of a rule. The **ExecRealmRule** script supports multivalued attributes with which you can configure to check for multiple Realms.

For example, the following statement checks the request packet for three realms. If one of these three realms is found in the request packet, the **ExecRealmRule** script sets the attributes to the values listed in the Attributes subdirectory of the rule that references the **ExecRealmRule** script.

```
set Realm "@cisco.com" "@foo.com" "#bar.com"
```

**Note**

Only the characters @ and # can be used as delimiters in ExecRealmRule.

Prior to Cisco Prime AR, ExecRealmRule was interpreted as a regular expression pattern and was evaluated accordingly. ExecRealmRule now does a simple case insensitive comparison by default of the value specified for the realm attribute for the realm of a username and optionally performs regular expression matching.

You can now specify a pattern using the following notation:

```
~/pattern/
```

Where pattern is a string of alpha-numeric characters that might include wild card characters, as in "@*cisco.com" to match patterns (realms) that end in *cisco.com*.

**Note**

The question mark (?) should not be used without a character pattern preceding it. Specifying ? as the first character might have undesirable results. (For regexp terminology, the question mark should be preceded by an *atom*.)

The **ExecRealmRule** script checks the request packet for the Realm and applies the values set for the following attributes:

- Authentication-Service
- Authorization-Service
- Policy

ExecDNISRule

Use the **ExecDNISRule** script to determine the Authentication service and Authorization service to be used to process the request packet based on the Called-Station-Id (DNIS) attribute. The DNIS for which the packet should be checked and the services can be configured through the Policy Engine. The **ExecDNISRule** script supports multivalued attributes, by which you can configure multiple DNIS for checking.

For example, the following statement checks for a Calling-Station-Id of 1111111, 2222222, or 3333333. If one of the DNIS values is true, the script applies the values set for the Authentication-Service, Authorization-Service, and Policy attributes.

```
set DNIS "1111111" "2222222" "3333333"
```

ExecCLIDRule

Use the **ExecCLIDRule** script with the Policy Engine to determine the Authentication service and Authorization service to be used to process the request packet based on the Calling-Station-Id (CLID) attribute. The CLID for which the packet should be checked and the services can be configured through the Policy Engine. **ExecCLIDRule** supports multivalued attributes by which you can configure multiple CLID for checking.

For example, the following statement checks for Calling-Station-ID and applies Authentication-Service, Authorization-Service, and Policy.

```
set CLID "1111111" "2222222" "3333333"
```

The **ExecCLIDRule** script checks the request packet for the Calling-Station-Id and applies the values set for the following attributes:

- Authentication-Service
- Authorization-Service
- Policy

ExecNASIPRule

The Policy Engine references the **ExecNASIPRule** script to determine the AAA Services, Policy and Session Manager based on the Client-IP-Address and Subnet-Mask set in the Policy Engine. The **ExecNASIPRule** script supports multi-value attributes by which multiple you can configure the Client-IP-Address and Subnet-Mask in **aregcmd** for checking.

For example, the following statements check for Client-IP-Address and Subnet-Mask and applies Authentication-Service, Authorization-Service, Accounting-Service, Policy, and Session-Manager.

```
set Client-IP-Address "1.1.1.1" "2.2.2.2" "3.3.3.3"

set Subnet-Mask "255.255.255.0" "255.255.0.0" "255.0.0.0"
```

The **ExecNASIPRule** script checks the request packet for the Client-IP-Address and Subnet-Mask and applies the values set for the following attributes:

- Authentication-Service
- Authorization-Service
- Accounting-Service
- Policy
- Session Manager

ExecPrefixRule

The Policy Engine references the **ExecPrefixRule** to determine the authentication and authorization services based on the prefix in the User-Name attribute of the request packet and assigns the appropriate service for processing the packet.

[Table 18-1](#) lists the **ExecPrefixRule** script attributes.

Table 18-1 *ExecPrefixRule Attributes*

Attribute	Description
Delimiters	A list of valid delimiters; you can use any character as a delimiter, such as @#-/.
Prefix	List of valid prefixes.
StripPrefix	Option to strip or not to strip the prefix from the User-Name. If you configure this attribute to YES, the ExecPrefixRule strips the prefix from the User-Name. If you configure this attribute to NO, the ExecPrefixRule does not strip the prefix from the User-Name. By default, this attribute is set to YES.

For example, if cisco/bob@abc.com is the User-Name attribute, the **ExecPrefixRule** script sets the Authentication-Service to abc-service and User-Name to:

- bob@abc.com when the StripPrefix attribute is set to YES.
- cisco/bob@abc.com when the StripPrefix attribute is set to NO.

You can configure the Prefix attribute in Cisco Prime AR using the `aregcmd` as follows:

set Prefix “cisco”

The Cisco Prime AR server does a case-insensitive comparison of the value specified for the prefix attribute of a username.

You can configure the Prefix by specifying a pattern using the following notation:

```
~/pattern/
[ //localhost/Radius/Rules/prefix/Attributes ]
Delimiters = #@-/
Prefix = ~/cis*/
```

Where a pattern is a string of alpha-numeric characters that can include wild card characters, as in “cis*” to match patterns (realms) that start with “cis”.



Note

If you specify / as the delimiter while configuring ExecPrefix Rule, you must configure the prefix as **Prefix =~/pattern//**.



Note

The question mark (?) should not be used without a character pattern preceding it. Specifying ? as the first character might have undesirable results. (For regexp terminology, the question mark should be preceded by an atom.)

ExecSuffixRule

The Policy Engine references **ExecSuffixRule** to determine the AAA services, policy and session managers based on the suffix (or *realm*) set in the Policy Engine. You can use **aregcmd** to configure **ExecSuffixRule** to support multivalued attributes, as in the following:

```
set Suffix “cisco.com” “abc.com” “domain.com”
```

In the User-Name *bob@abc.com*, **ExecSuffixRule** first checks for any of the configured delimiters in the User-Name. If there is a match, **ExecSuffixRule** checks for the configured suffix in the User-Name. If the suffix matches, **ExecSuffixRule** checks for the value of the StripSuffix variable. If StripSuffix is set to Yes, the suffix (including the delimiter) is stripped from the User-Name attribute of the Access Request.

Table 18-2 lists the **ExecSuffixRule** script attributes.

Table 18-2 ExecSuffixRule Attributes

Attribute	Description
Delimiters	A list of valid delimiters; you can use any character as a delimiter such as these: @#/
Suffix	List of valid suffixes to scan
StripSuffix	The default value (No) does not strip the suffix from the User-Name. When set to Yes, ExecSuffixRule does strip the suffix.

The Cisco Prime AR server does a case-insensitive comparison of the value specified for the suffix attribute for the suffix of a username.

You can also specify a pattern using the following notation:

```
~/pattern/
```

Where pattern is a string of alpha-numeric characters that might include wild card characters, as in “@*cisco.com” to match patterns (realms) that end in *cisco.com*.



Note

The question mark (?) should not be used without a character pattern preceding it. Specifying ? as the first character might have undesirable results. (For regexp terminology, the question mark should be preceded by an *atom*.)

Configuring Suffix and Prefix Policies

Step 1 Activate the Policy Engine by configuring SelectPolicy.

For example, the following script explains you how to set a suffix and prefix policy in the Grouping list.

```
--> cd selectPolicy/

[ //localhost/Radius/Policies/SelectPolicy ]
  Name = SelectPolicy
  Description =
  Grouping = suffixrule&prefixrule
```

Step 2 Run the configuration rules for Prefix and Suffix.

For example, the suffix and prefix rule configuration do the following:

- points to the **ExecSuffixRule** script
- specifies the delimiters for which to scan
- specifies the suffixes for which to scan
- indicates whether to strip the suffix from the User-Name

```
[ //localhost/Radius/Rules ]
  Entries 1 to 2 from 2 total entries
  Current filter: <all>

  prefixrule/
    Name = prefixrule
    Description =
    Type = radius
    Script~ = ExecPrefixRule
    Attributes/
      Authentication-Service = local-users
      Authorization-Service = local-users
      Delimiters = @#%$/
      Prefix = cisco
      StripPrefix = no
  suffixrule/
    Name = suffixrule
    Description =
    Type = radius
    Script~ = ExecRealmRule
    Attributes/
```

```
Realm = @cisco.com
```

In this example, if *bob@abc.com* is the User-Name attribute, **ExecSuffixRule** strips the User-Name *bob@abc.com* and sets the User-Name environment variable to *bob* because StripSuffix is configured as *yes*.

ExecTimeRule

Use the **ExecTimeRule** script to implement access restriction on users based on time. The **ExecTimeRule** script checks the time at which the request packet arrives and based on that the authorization parameters for the user can be decided. Based on the time of the request packet if the rule succeeds then **ExecTimeRule** sets the environment variable, Acceptedprofiles to a profile or a set of profiles.

For example, the following statement checks for Timerange and applies AcceptedProfiles.

```
Acceptedprofiles=Regularaccess::Highprivilegeaccess
```

ParseTranslationGroupsByRealm

The Policy Engine references the ParseTranslationGroupsByReal script to determine the incoming and outgoing translation groups based on realm set in the Policy Engine. Use the ParseTranslationGroupsByReal script to add or filter attributes in request and response packets. The ParseTranslationGroupsByReal script supports multi-value attributes enabling you to configure to check for multiple Realms.

For instance, the following statement checks for three Realms. If True, the Policy Engine applies the values set for the Incoming-Translation-Group and Outgoing-Translation-Groups attributes.

```
set Realm "@cisco.com" "@foo.com" "@bar.com"
```

ParseTranslationGroupsByDNIS

This script is referenced from the Policy Engine to determine the incoming and outgoing translation groups based on DNIS set in the Policy Engine. This script can be used to add/filter attributes in request/response packets. This script supports multi-value attributes, by which multiple DNIS can be configured for checking.

For example, the following statement checks for Calling-Station-ID and applies Incoming-Translation-Groups and Outgoing-Translation-Groups.

```
set DNIS "111111" "222222" "333333"
```

ParseTranslationGroupsByCLID

The Policy Engine references the ParseTranslationGroupsByCLID script to determine the incoming and outgoing translation groups based on CLID set in the Policy Engine. You can use the ParseTranslationGroupsByCLID script to add and filter attributes in request and response packets. The ParseTranslationGroupsByCLID script supports multi-value attributes, by which you can configure multiple CLIDs for checking.

For example, the following statement checks for the Calling-Station-ID and applies Incoming-Translation-Groups and Outgoing-Translation-Groups.

```
set CLID "1111111" "2222222" "3333333"
```

ParseTranslationGroupsByDNIS

The ParseTranslationGroupsByDNIS script is referenced from the policy engine to determine the incoming and outgoing translation groups based on DNIS set in the policy engine. The ParseTranslationGroupsByDNIS script can be used to add and/or filter attributes in request and response packets. The ParseTranslationGroupsByDNIS script supports multi-value attributes, by which multiple DNIS can be configured for checking.

For example, the following statement checks for the Calling-Station-ID and applies Incoming-Translation-Groups and Outgoing-Translation-Groups.

```
set DNIS "1111111" "2222222" "3333333"
```



CHAPTER 19

Wireless Support

This chapter provides the following information about using Cisco Prime Access Registrar (Cisco Prime AR) for wireless support:

- [Mobile Node-Home Agent Shared Key](#)
- [3GPP2 Home Agent Support](#)
- [Session Correlation Based on User-Defined Attributes](#)
- [Managing Multiple Accounting Start/Stop Messages](#)
- [NULL Password Support](#)
- [New 3GPP2 VSAs in the Cisco Prime Access Registrar Dictionary](#)

Mobile Node-Home Agent Shared Key

In a mobile wireless environment, a Home Agent (HA) can request a Mobile Node-Home Agent (MN-HA) shared key from the home Cisco Prime AR RADIUS server during a mobile IP registration request (RRQ) from a Packet Data Serving Node (PDSN). Cisco Prime AR supports distribution of the shared key in this environment. Cisco Prime AR encrypts the shared key using MD5 encryption before sending the key back to the HA in an Access-Accept packet.

When an HA receives an RRQ from a PDSN, the HA authenticates the RRQ using a MN-HA shared key. If the HA does not have the MN-HA shared key, it retrieves the MN-HA shared key from the Cisco Prime AR server by sending an Access-Request packet containing the 3GPP2 VSA CDMA-MN-HA-SPI (SPI attribute). Cisco Prime AR then sends the CDMA-MN-HA-Shared-Key corresponding to the user if the user has been successfully authenticated.

This section contains the following topics:

- [Use Case Example](#)
- [Configuring User Attributes](#)

Use Case Example

When HA receives an RRQ from a PDSN, it authenticates the RRQ by using a MN-HA shared key. If the HA does not have the MN-HA shared key, it retrieves the MN-HA shared key from the Cisco Prime AR server by sending an Access-Request packet containing the 3GPP2 vendor-specific attribute (VSA) CDMA-MN-HA-SPI, the Security Parameter Index (SPI attribute).

The Cisco Prime AR server then sends the CDMA-MN-HA-Shared-Key corresponding to the user if the user has successfully authenticated subject to the following rules:

1. If there is an incoming SPI and no configured SPI, the Cisco Prime AR server authenticates the user as usual and does not include a configured shared-key (if there is one) in the reply.
2. If the incoming SPI does not match the configured SPI, the Cisco Prime AR server authenticates the user as usual, but does not include the configured shared-key (if there is one) in the reply.
3. If the incoming SPI matches the configured SPI, but there is no shared-key configured, the Cisco Prime AR server proceeds with normal authentication. Since there is no shared-key, it will not be included in the reply.
4. If the incoming SPI matches the configured SPI and a configured shared-key exists, the Cisco Prime AR server proceeds to encrypt the MCD5 shared-key and include it in the Access-Accept.

The key to including the shared key in an Access-Accept is in matching the values of the SPI attribute.

Configuring User Attributes

Cisco Prime AR server supports user-specific attributes which enables the Cisco Prime AR server to return attributes on a per-user or per-group basis without having to use profiles.

Configuring the User Attributes

To configure a user with the CDMA-MN-HA-SPI VSA to request a MN-HA shared key:

-
- Step 1** Log in to the Cisco Prime AR server and launch **aregcmd**.
Log in as a user with administrative rights such as user **admin**.
- Step 2** Change directory to the attribute directory of the user.
- ```
cd /Radius/UserLists/Default/bob/Attributes
```
- Step 3** Set the CDMA-MN-HA-SPI VSA to the appropriate shared-key value.
- ```
set CDMA-MN-HA-SPI 1124
```
- ```
set CDMA-MN-HA-SPI 1124
```
- Step 4** Set the CDMA-MN-HA-SPI VSA to the appropriate shared-key value.
- ```
set CDMA-MN-HA-Shared-Key secret112
```
- ```
set CDMA-MN-HA-Shared-Key secret112
```
- Step 5** Validate and save your changes.
- ```
validate
```
- ```
save
```
-

# 3GPP2 Home Agent Support

The Cisco Prime AR server supports 3GPP2 home agents. This support enables mobile IP clients that authenticate through a Cisco Prime AR RADIUS server to be told which home agent they should use.

Every Mobile IP client has a home domain that is served by a group of Home Agents (HA). The Mobile IP client sets up a tunnel to one (and only one) HA during a session while it roams. Typically, the domain can be determined by the Mobile IP client's network access identifier (NAI).

**Note**

The NAI is the userID submitted by the client during PPP authentication. In roaming, the purpose of the NAI is to identify the user as well as to assist in the routing of the authentication request.

During the authentication and authorization phase for each Mobile IP client, the RADIUS server must decide which HA from a group of HAs should be chosen to serve the client. This is called dynamic HA assignment.

This section contains the following topics:

- [Home-Agent Resource Manager](#)
- [Querying and Releasing Sessions](#)
- [Access Request Requirements](#)
- [New 3GPP2 VSAs in the Cisco Prime Access Registrar Dictionary](#)

## Home-Agent Resource Manager

Cisco Prime AR supports dynamic HA assignment with a new resource manager type called home-agent. You configure the home-agent resource manager with a list of IP addresses. The Cisco Prime AR server assigns those addresses to clients whose request dictionary has the right attributes to indicate that an assignment should be done. This is similar to the *ip-dynamic* resource manager.

Unlike the *ip-dynamic* resource manager, HAs are not exclusively allocated to an individual session but are shared among a set of sessions.

## Load Balancing

The goal of dynamic HA assignment is to have load balancing among HAs. The Cisco Prime AR server achieves this by evenly distributing mobile clients among HAs. At the same time, the Cisco Prime AR server ensures that the same HA is always assigned to the same Mobile IP client for the same session.

### Configuring the Home Agent Resource Manager

To create a new resource manager using the **aregcmd** command:

- 
- Step 1** Use the **cd** command to change to the **Radius/ResourceManagers** level.
- ```
--> cd /Radius/ResourceManagers

[ //localhost/Radius/ResourceManagers ]
  Entries 0 to 0 from 0 total entries
  Current filter: <all>
```
- Step 2** Use the **add** command to specify the name of a resource manager to create.
- ```
--> add home-agent-pool
--> Added home-agent-pool
```
- Step 3** Use the **cd** command to change to the **Radius/ResourceManagers/home-agent-pool** level.
- ```
--> cd home-agent-pool

[ //localhost/Radius/ResourceManagers/home-agent-pool ]
  Name = home-agent-pool
  Description =
  Type =
```
- Step 4** Use the **set** command to set the resource manager type to **home-agent**.
- ```
--> set type home-agent
```
- Step 5** Use the **ls** command to view the subdirectories under **home-agent-pool**.
- ```
--> ls

[ //localhost/Radius/ResourceManagers/home-agent-pool ]
  Name = home-agent-pool
  Description =
  Type = home-agent
  Home-Agent-IPAddresses/
```
- Step 6** Use the **cd** command to change to the **Radius/ResourceManagers/home-agent-pool/Home-Agent-IPAddresses** level.
- ```
--> cd Home-Agent-IPAddresses

[//localhost/Radius/ResourceManagers/home-agent-pool/Home-Agent-IPAddresses]
```
- Step 7** Use the **add** command to add a single IP address or a range of IP addresses.
- ```
--> add 209.165.200.200-209.165.200.254
--> Added 209.165.200.200-209.165.200.254
```
-

Querying and Releasing Sessions

The **aregcmd** program has been modified to support a new filter for **query-session** and **release-session**. You can use this filter to restrict a request (either query or release) to just the sessions with a given home-agent IP address. For example, consider the following command line.

```
--> query-session /radius with-home-agent 10.10.10.1
```

This command line will return all sessions that have a home-agent resource equal to the IP address 10.10.10.1.

Querying sessions using **aregcmd** displays the home-agent resource in each session as:

```
HA ddd.ddd.ddd.ddd
```

where each *ddd* is a decimal number from 0-255.

Access Request Requirements

When the home-agent resource manager receives an Access-Request that contains a CDMA-HA-IP-Addr attribute, the home-agent resource manager checks the response dictionary to see if it already has a CDMA-HA-IP-Addr attribute. If it does, then the Mobile IP client has been assigned a HA address already and the resource manager does not need to do anything.

If the value of the CDMA-HA-IP-Addr attribute in the request dictionary is 0.0.0.0, the home-agent resource manager assigns a HA and puts a new CDMA-HA-IP-Addr attribute whose value is the IP address of the HA in the response dictionary.

If the value of the CDMA-HA-IP-Addr attribute is not 0.0.0.0, the Mobile IP client has been assigned a HA address already. The home-agent resource manager copies the attribute (with its value) from the request dictionary into the response dictionary.

The Cisco Prime AR server might select the session manager based on the domain (using the rule engine, dynamic properties, or scripting), and it allows each session manager to have its own home-agent resource manager.

New 3GPP2 VSAs in the Cisco Prime Access Registrar Dictionary

Cisco Prime AR supports 3GPP2 vendor-specific attributes (VSAs) in the vendor-specific dictionary in **/Radius/Advanced/Attribute Dictionary**.



Note

There is no planned support for the Accounting-Container (3GPP2/6) attribute because it has different syntax than other vendor-specific attributes (VSAs) and requires special processing.

Session Correlation Based on User-Defined Attributes

All the session objects are maintained in one dictionary keyed by a string.

You can define the keying material to the session dictionary through a newly introduced environment variable, **Session-Key**. If the **Session-Key** is presented at the time of session manager process, it will be used as the key to the session object for this session. The **Session-Key** is of type string. By default, the **Session-Key** is not set. Its value should come from attributes in the incoming packet and is typically set by scripts. For example, **CLID** can be used to set the value of **Session-Key**.

Use the script `UseCLIDAsSessionKey` as defined in the script `rexscript.c` to specify that the `Calling-Station-Id` attribute that should be used as the session key to correlate requests for the same session. This is a typical case for 3G mobile user session correlation. You can provide your own script to define other attributes as the session key.

In the absence of the `Session-Key` variable, the key to the session will be created based on the string concatenated by the value of the `NAS` and the `NAS-Port`.

There is a new option *with-key* available in `aregcmd` for query-sessions and release-sessions to access sessions by `Session-Key`.

Managing Multiple Accounting Start/Stop Messages

Since the PDSN is aware when it sends a RADIUS stop followed by a start record, it inserts the new Session Continue attribute (3GPP2/48) into the stop record. The existence of the Session Continue attribute denotes that a start record will immediately be sent and the packet data session continues on the PDSN.

When Cisco Prime AR receives an accounting stop packet, the following two conditions trigger a release of a session and its resources:

- There is no 3GPP2/48 Session Continue attribute in the stop packet and the number of accounting stops received is greater or equal to the starts received for this session
- The 3GPP2/48 Session Continue attribute is present in the stop packet, but its value is zero (0)



Note

One of the conditions above must be true to release the session and its resources.

NULL Password Support

Cisco Prime AR introduced a new Cisco Prime AR environment variable, *Allow-NULL-Password*. At authentication time, if the following three conditions are met, user authentication is bypassed:

1. `Allow-NULL-Password` environment variable is set to `TRUE`.
2. The `User-Password` or `CHAP-Password` must be `NULL` in the incoming request. (If it is not `NULL`, normal password checking will occur.)
3. A user record exists for this user.

By default, the *Allow-NULL-Password* environment variable is not set.



Note

You should be aware of the security impact when using the NULL Password feature.

You can set this environment variable three different ways:

1. For the user in local database, one new field ***AllowNullPassword*** is added in the user record. When Cisco Prime AR fetches a user record for authentication, if this field is set to TRUE and Allow-NULL-Password environment variable does not exist, it sets *Allow-NULL-Password* environment variable to TRUE.
2. If the user record is in LDAP database, then the *LDAPToEnvironmentMappings* must be defined to map an attribute in LDAP user record to *Allow-NULL-Password* environment variable.
3. Through scripting which allows the decision to be made based on runtime conditions, such as attributes in the access-request or policies.



CHAPTER 20

Using LDAP

This chapter provides information about using Lightweight Directory Access Protocol (LDAP) with Cisco Prime Access Registrar (Cisco Prime AR) to access information directories. You can use Cisco Prime AR to authenticate and authorize access requests by querying user information through LDAP.



Note

Cisco Prime AR supports LDAP version 3 and LDAP version 2 directory servers.

This chapter contains the following sections:

- [Configuring LDAP](#)
- [Analyzing LDAP Trace Logs](#)
- [Bind-Based Authentication for LDAP](#)

Configuring LDAP

To use LDAP in Cisco Prime AR, use **aregcmd** to do the following:

1. [Configuring the LDAP Service.](#)
2. [Configuring an LDAP RemoteServer.](#)
3. [Setting LDAP As Authentication and Authorization Service.](#)
4. [Saving Your Configuration.](#)

After you issue the **save** command, Cisco Prime AR attempts to validate the configuration, checks for all required properties, and ensures there is no logic error. If the validation is successful, Cisco Prime AR saves the configuration to the MCD database. When Cisco Prime AR is reloaded, it shuts down any current LDAP connections and builds new connections for the configured LDAP remote servers.

Configuring the LDAP Service

You configure an LDAP service under **/Radius/Services**. When you define an LDAP service under **/Radius/Services**, you must set its type to LDAP.

```
[ //localhost/Radius/Services/AR-LDAP ]
  Name = AR-LDAP
  Description =
  Type = ldap
  IncomingScript~ =
  OutgoingScript~ =
  OutagePolicy~ = RejectAll
  OutageScript~ =
  MultipleServersPolicy = Failover
  RemoteServers/
```

Table 20-1 describes the LDAP service properties.

Table 20-1 LDAP Service Properties

Parameter	Description
Name	Required; inherited from the upper directory
Description	An optional description of the service
Type	Must be set to LDAP for LDAP service
IncomingScript	Optional
OutgoingScript	Optional
OutagePolicy	Required; must be set to AcceptAll or Drop Packet, or defaults to RejectAll
OutageScript	Optional
MultipleServersPolicy	Required; must be set to RoundRobin or defaults to Failover.
RemoteServers	Required; list of one or more remote servers defined under /Radius/Services/LDAP/RemoteServers . These servers must be listed in order under /Radius/RemoteServers .

This section contains the following topics:

- [MultipleServersPolicy](#)
- [RemoteServers](#)

MultipleServersPolicy

Use the MultipleServersPolicy property to configure the LDAP remote servers in RoundRobin mode, or the default Failover mode applies. When set to Failover, Cisco Prime AR directs requests to the first server in the **/Radius/Services/LDAP/RemoteServers** list. If that server should fail or go offline, Cisco Prime AR redirects all requests to the next server in the list. The process continues until Cisco Prime AR locates an online server.

When set to RoundRobin, Cisco Prime AR directs each request to the next server in the RemoteServers list to share the resource load across all listed servers.

RemoteServers

Use the RemoteServers directory to list one or more remote servers to process access requests. The servers must also be listed in order under **/Radius/RemoteServers**.

The order of the RemoteServers list determines the sequence for directing access requests when MultipleServersPolicy is set to RoundRobin mode. The first server in the list receives all access requests when MultipleServersPolicy is set to Failover mode.

Configuring an LDAP RemoteServer

Use the **aregcmd** command **add** to add LDAP servers under **/Radius/RemoteServers**. You must configure an LDAP RemoteServer object for each RemoteServer object you list under **/Radius/Services/LDAP/RemoteServers**.

The *Name*, *Protocol*, *Port*, *HostName*, *BindName*, *BindPassword*, *SearchPath*, and *Filter* properties must be configured to use an LDAP remote server.

The *Name*, *Protocol*, *Port*, *HostName*, *SearchPath*, and *Filter* properties must be configured to enable Bind-Based Authentication.



Note

You can leave the BindName, BindPassword, UserPasswordAttribute, PasswordEncryptionStyle and DNSLookupAndLDAPRebindInterval properties blank when you configure the Bind-Based Authentication feature in Cisco Prime AR.

Table 20-2 describes the LDAP Remote Server properties.

Table 20-2 LDAP Remote Server Properties

Parameter	Description
Name	Required name you assign
Description	Optional description of the server
Protocol	Required and must be set to LDAP; no default value
Port	Required; port on which LDAP server listens, default is port 389. Note If port is not set or set to zero, LDAP remote server will automatically be set to port 389.
ReactivateTimerInterval	Required; default is 300000 (ms)
Timeout	Required; specifies length of time Cisco Prime AR waits for a response from the LDAP server before noting the server as down; default is 15 (seconds)
HostName	Required; specifies the hostname, FQDN, or IP address of the LDAP server
BindName	Specifies the distinguished name (DN) in the LDAP server for Cisco Prime AR to bind with the LDAP server
BindPassword	Specifies the password for the distinguished name
UseSSL	FALSE by default

Table 20-2 LDAP Remote Server Properties (continued)

Parameter	Description
SearchPath~	Specifies search base to the organization and domain; for example: o=cisco.com
Filter~	(uid=%s) by default
UserPasswordAttribute	Should be set to the attribute in the directory server which stores users' passwords; default is <i>userpassword</i>
LimitOutstandingRequests	FALSE by default
MaxOutstandingRequests	Limits the number of requests to the LDAP server; used to throttle the request load when the LDAP server does not function well under high TPS rates (default is 0)
MaxReferrals	Limits the number of referrals Cisco Prime AR allows when working with LDAPv2 (default is 0)
ReferralAttribute	LDAP attribute that contains a referral for LDAPv2
ReferralFilter	Filter used when following a referral for LDAPv2
PasswordEncryptionStyle	<p>Dynamic by default; must be set to one of the following depending on the algorithm used by the LDAP server to encrypt passwords:</p> <ul style="list-style-type: none"> Dynamic Crypt None SHA-1 SSHA-1 <p>When set to <i>Dynamic</i>, Cisco Prime AR analyzes the password and detects the encryption algorithm used.</p> <p><i>None</i> indicates that the LDAP server stores clear text passwords.</p> <p>Note If CHAP authentication is used with LDAP backing store, passwords in LDAP must be stored as clear text.</p>
EscapeSpecialCharInUserName	FALSE by default
DNSLookupAndLDAPRebindInterval	Specifies the timeout period after which the Cisco Prime AR server will attempt to resolve the LDAP hostname to IP address (DNS resolution); 0 by default
DataSourceConnections	Specifies the number of concurrent connections to the LDAP server. The default value is 8.
SearchScope	<p>Specifies how deep to search within a search path; default is <i>SubTree</i> which indicates a search of the base object and the entire subtree of which the base object distinguished name is the highest object.</p> <p><i>Base</i> indicates a search of the base object only.</p> <p><i>OneLevel</i> indicates a search of objects immediately subordinate to the base object, but does not include the base object.</p>

Table 20-2 LDAP Remote Server Properties (continued)

Parameter	Description
LDAPToRadiusMappings	<p>Optional; a list of name/value pairs in which the name is the name of the ldap attribute to retrieve from the user record, and the value is the name of the RADIUS attribute to set to the value of the ldap attribute retrieved.</p> <p>For example, when the LDAPToRadiusMappings has the entry: FramedIPAddress = Framed-IP-Address, the RemoteServer retrieves the FramedIPAddress attribute from the ldap user entry for the specified user, uses the value returned, and sets the Response variable Framed-IP-Address to that value.</p>
LDAPToEnvironmentMappings	<p>Optional; a list of name/value pairs in which the name is the name of the ldap attribute to retrieve from the user record, and the value is the name of the Environment variable to set to the value of the ldap attribute retrieved.</p> <p>For example, when the LDAPToEnvironmentMappings has the entry: group = User-Group, the RemoteServer retrieves the group attribute from the ldap user entry for the specified user, uses the value returned, and sets the Environment variable User-Group to that value.</p>
LDAPToCheckItemMappings	<p>Optional; a list of LDAP <i>attribute/value</i> pairs which must be present in the RADIUS access request and must match, both name and value, for the check to pass.</p> <p>For example, when the LDAPToCheckItemMappings has the entry: group = User-Group, the Access Request must contain the attribute group, and it must be set to User-Group.</p>
UseBindBasedAuthentication	<p>A boolean field that enables bind-based authentication with LDAP server. By default, this property is set to FALSE that uses existing legacy authentication method.</p> <p>On setting this property to TRUE, the mappings LDAPToRadius, LDAPToEnvironment, and LDAPToCheckItem will not work.</p>
UseBinaryPasswordComparison	<p>A boolean value that enables binary-based password comparison to authenticate. This property when set to TRUE, enables binary password comparison. By default this property is set to FALSE.</p>

This section contains the following topics:

- [DNS Look Up and LDAP Rebind Interval](#)
- [LDAPToRadiusMappings](#)
- [LDAPToEnvironmentMappings](#)
- [LDAPToCheckItemMappings](#)

DNS Look Up and LDAP Rebind Interval

Cisco Prime AR provides a DNS Look-up and LDAP Rebind feature that enables you to use a smart DNS server for LDAP hostname resolution, allows you to query a DNS server at set intervals to resolve the LDAP hostname, and optionally rebind to the LDAP server, if necessary.

When you configure Cisco Prime AR to use an LDAP directory server, you can specify the hostname of the LDAP directory server. The hostname can be a qualified or an unqualified name. You can also specify a timeout period after which Cisco Prime AR will again resolve the hostname. If the IP address returned is different from the previous, Cisco Prime AR establishes a new LDAP bind connection.

The `DNSLookupAndLDAPRebindInterval` property specifies the timeout period after which the Cisco Prime AR server will attempt to resolve the LDAP hostname to IP address (DNS resolution). When you do not modify `DNSLookupAndLDAPRebindInterval`, the default value zero indicates the server will perform normal connection and binding only at start-up time or during a reload. Unless you change the default to a value greater than zero, the server will not perform periodic DNS lookups.

Cisco Prime AR maintains and uses the existing bind connection until a new one is established to minimize any performance impact during the transfer. Cisco Prime AR ensures that no requests are dropped or lost during the transfer to a new LDAP binding.

Set the `DNSLookupAndLDAPRebindInterval` using a numerical value and the letter H for hours or M for minutes, such as in the following examples:

```
set DNSLookupAndLDAPRebindInterval 15M—performs DNS resolution every 15 minutes
```



Note

We recommend that you do not set `DNSLookupAndLDAPRebindInterval` to a value less than 15 minutes to minimize its effect on server performance.

```
set DNSLookupAndLDAPRebindInterval 1h—performs DNS resolution every hour
```

Configure the DNS Look-up and LDAP Rebind

To configure the DNS Look-up and LDAP Rebind,

-
- Step 1** Log in to the Cisco Prime AR server, and use `aregcmd` to navigate to `//localhost/Radius/Remoteservers`. If necessary, add the LDAP server, or change directory to it.

```
cd /Radius/RemoteServers/ldap-serv1/
```

- Step 2** Set the `DNSLookupAndLDAPRebindInterval` property to the interval time desired.

```
set DNSLookupAndLDAPRebindInterval 30 M
```

LDAP Rebind Failures

Cisco Prime AR records any name resolution failures, bind successes and failures, and the destination hostname and IP address in the log file. At trace level 3, Cisco Prime AR also logs the time of any new bind connections and the closing of any old bind connections.

If either the name resolution or bind attempt fail, Cisco Prime AR continues using the existing bind connection until the timeout has expired again. If there is no existing bind connection, Cisco Prime AR marks the remote server object as *down*.

LDAPToRadiusMappings

Configure LDAPToRadiusMappings with a list of *name/value* pairs where name is the name of the data store attribute to retrieve from the user record and the value is the name of the RADIUS attribute to set to the value of the data store attribute retrieved.

Values stored in a multivalued field in the LDAP directory are mapped to multiple RADIUS attributes. For example, if the LDAPToRadiusMappings has the following entry:

```
tunnel-info = Cisco-AVPair
```

The following LDAP fields in the user's record will create four Cisco-AVPair attributes in the user's Access-Accept RADIUS packet:

```
tunnel-info: vpdn:tunnel-id=ssg001
tunnel-info: vpdn:tunnel-type=12tp
tunnel-info: vpdn:ip-addresses=10.2.2.2
tunnel-info: vpdn:12tp-tunnel-password=secret
```

LDAPToEnvironmentMappings

LDAPToEnvironmentMappings comprises a list of attribute name/value pairs or AV pairs where the name is the name of the data store attribute to retrieve from the user record, and the value is the name of the Environment variable to set to the value of the LDAP attribute retrieved.

For example, when the LDAPToEnvironmentMappings has the entry: group=User-Group, the RemoteServer retrieves the attribute from the LDAP user entry for the specified user, uses the value returned, and sets the Environment variable User-Group to that value.

LDAPToCheckItemMappings

LDAPToCheckItemMappings comprises a list of LDAP AV pairs which must be present in the RADIUS access request and must match, both name and value, for the check to pass. Cisco Prime AR will first authenticate the user's password in the Access-Request before validating the check item attributes.

Setting LDAP As Authentication and Authorization Service

Use **aregcmd** to configure the LDAP Service as the default authentication and authorization service under **/Radius** as in the following:

```
set DefaultAuthenticationService AR-LDAP
```

```
set DefaultAuthorizationService AR-LDAP
```

Saving Your Configuration

When you use **aregcmd** to **save** your configuration, Cisco Prime AR does the following:

- Attempts to validate the configuration
- Checks for all required parameters
- Ensures there are no logic errors

If the validation is successful, Cisco Prime AR saves the configuration to the MCD database. When you **reload**, Cisco Prime AR shuts down any current LDAP connections and builds new connections for the configured LDAP servers.

This section contains the following topics:

- [CHAP Interoperability with LDAP](#)
- [Allowing Special Characters in LDAP Usernames](#)
- [Dynamic LDAP Search Base](#)

CHAP Interoperability with LDAP

If you plan to use CHAP authentication with an LDAP backing store, the password in LDAP must be stored as clear text. This is due to the one-way hash used by the CHAP, crypt, SHA-1, and SSHA encryption algorithms.

Allowing Special Characters in LDAP Usernames

This feature allows you to use special characters in LDAP usernames. The allowable special characters are *, (, and \. These special characters can be included in the string passed to LDAP as the LDAP username value (usually the RADIUS username attribute).

The default of `EscapeSpecialCharInUserName` is `FALSE`. To enable this feature, use `aregcmd` to set the `EscapeSpecialCharInUserName` attribute in `/Radius/RemoteServers/ldap-server` to `TRUE`, as shown in the following example.

```
cd /Radius/RemoteServers/ldap-server

set EscapeSpecialCharInUserName TRUE

/Radius/RemoteServers/Ldap-Server
EscapeSpecialCharInUserName = TRUE
```



Note

This feature supports the LDAP V3 library.

Dynamic LDAP Search Base

A new environment variable, `Dynamic-Search-Path` (see `rex.h`), can be used to set the dynamic LDAP search base. If this environment variable is defined for an LDAP service, it will override the default LDAP search base defined in the LDAP Remote Server configuration. This allows the LDAP search base to be configured on a per-user basis.

For example, you could match the search base to the organization and domain (in a Tcl script called from `/Radius/IncomingScript`):

```
set user [ $request get User-Name ]
if { [ regexp {^[^@]+@[^\.\.]+\.(.+)$} $user m org domain ] } {
$environ put Dynamic-Search-Path "ou=$org,ou=people,o=$domain"
```

Analyzing LDAP Trace Logs

Cisco Prime AR records in the log files any name resolution failures, bind successes and failures, and the destination hostname and IP address. At trace level 3, Cisco Prime AR logs the time of any new bind connections and the closure of any old bind connections and also information about user login requests and reply messages.

This section contains the following topics:

- [Successful Bind Message](#)
- [Bind Failure Messages](#)
- [Login Failure Messages](#)

Successful Bind Message

The following message is logged in the **name_radius_1_trace** file, when the Cisco Prime AR server successfully binds to the LDAP server. In this case, spatula-u5 is the LDAP server listening on port number 389.

```
10/12/2012 11:02:57: Log: Successfully bind to LDAP Server ldapserver (spatula-u5:389)
```

Bind Failure Messages

The following messages are logged in the **name_radius_1_trace** file, when Cisco Prime AR server fails to bind to the LDAP server.

```
10/12/2012 11:10:50: Log: Write in LDAPClient returned an error (32)
```

```
10/12/2012 11:10:50: Log: Remote LDAP Server ldapserver (spatula-u5:387): Unable to bind to LDAP Server: Can't contact LDAP server
```

```
10/12/2012 11:10:50: Log: Remote LDAP Server ldapserver (spatula-u5:387): Failed to open the connection to the LDAP server
```

Messages like those above could indicate that the hostname specified does not resolve to the correct IP address of the LDAP server or the configured port number might not be the port on which the LDAP server listens.

The following messages are logged in the **name_radius_1_trace** file, when Cisco Prime AR server fails to bind to the LDAP server.

```
10/12/2012 11:45:14: Log: Remote LDAP Server ldapserver (spatula-u5:389): Unable to bind to LDAP Server: No such object ()
```

```
10/12/2012 11:45:14: Log: Remote LDAP Server ldapserver (spatula-u5:389): Failed to open the connection to the LDAP server
```

The Distinguished Name (DN) provided in the BindName property was invalid. The DN provided in the BindName property should contain the exact string used in the directory server to define the object.

The following messages are logged in the **name_radius_1_trace** file, when Cisco Prime AR server fails to bind to the LDAP server.

```

10/12/2012 11:51:55: Log: Remote LDAP Server ldapserver (spatula-u5:389): Unable to
bind to LDAP Server: Invalid credentials
10/12/2012 11:51:55: Log: Remote LDAP Server ldapserver (spatula-u5:389): Failed to
open the connection to the LDAP server

```

The messages above indicate that the password provided in the BindPassword property was incorrect.

Login Failure Messages

The following messages are logged in the **name_radius_1_trace** file, when user *jane* tries to login. These messages indicate that user *jane* does not have a record in the directory server or the SearchPath property has an incorrect value. The SearchPath property should have the directory where the user record is stored in the directory server.

Notice how the messages specify the service, remote LDAP server, username, and contents of the Access-Reject packet.

```

10/12/2012 11:24:17: P8457: Authenticating and Authorizing with Service AR-LDAP
10/12/2012 11:24:17: id = 5
10/12/2012 11:24:17: P8457: Remote LDAP Server ldapserver (spatula-u5: 389): Querying
LDAP server, id = 5.
10/12/2012 11:24:17: P8457: Remote LDAP Server ldapserver (spatula-u5: 389): GotLDAP
response, id = 5.
10/12/2012 11:24:17: P8457: Remote LDAP Server ldapserver (spatula-u5: 389): No
matching entries returned from LDAP query.
10/12/2012 11:24:17: P8457: User jane was not found in the LDAP store
10/12/2012 11:24:17: P8457: Rejecting request
10/12/2012 11:24:17: P8457: Rejecting request
10/12/2012 11:24:17: P8457: Trace of Access-Reject packet
10/12/2012 11:24:17: P8457: identifier = 4
10/12/2012 11:24:17: P8457: length = 35
10/12/2012 11:24:17: P8457: reqauth = 01:ad:cf:c7:4f:8e:a4:38:b0:d8:0a:e5:3d:9f:64:16
10/12/2012 11:24:17: P8457: Reply-Message = Access Denied

```

The following messages are logged in the **name_radius_1_trace** file, when user *bob* tries to login. These messages indicate that user *bob* tried to login with an incorrect password.

```

10/12/2012 11:36:59: P8461: Authenticating and Authorizing with Service AR-LDAP
10/12/2012 11:36:59: id = 7
10/12/2012 11:36:59: P8461: Remote LDAP Server ldapserver (spatula-u5: 389): Querying
LDAP server, id = 7.
10/12/2012 11:36:59: P8461: Remote LDAP Server ldapserver (spatula-u5: 389): Got LDAP
response, id = 7.
10/12/2012 11:36:59: P8461: Remote Server ldapserver (spatula-u5:389): User bob's
password does not match
10/12/2012 11:36:59: P8461: User bob's password does not match
10/12/2012 11:36:59: P8461: Rejecting request
10/12/2012 11:36:59: P8461: Rejecting request
10/12/2012 11:36:59: P8461: Trace of Access-Reject packet
10/12/2012 11:36:59: P8461: identifier = 6
10/12/2012 11:36:59: P8461: length = 35
10/12/2012 11:36:59: P8461: reqauth = de:8d:4b:c4:f9:c0:06:a6:98:2d:8c:e9:f3:a9:a3:c2
10/12/2012 11:36:59: P8461: Reply-Message = Access Denied

```

The following messages are logged in the **name_radius_1_trace** file, when user *bob* tries to login. These messages indicate the user record for user *bob* does not contain an attribute called pass. The UserPasswordAttribute property has an incorrect value called *pass*. The UserPasswordAttribute property should have the attribute name in the directory records where the user password is stored.

```

10/12/2012 12:02:09: P9865: Authenticating and Authorizing with Service AR-LDAP
10/12/2012 12:02:09: id = 2

```

```

10/12/2012 12:02:09: P9865: Remote LDAP Server ldapserver (spatula-u5: 389): Querying
LDAP server, id = 2.
10/12/2012 12:02:09: P9865: Remote LDAP Server ldapserver (spatula-u5: 389): Got LDAP
response, id = 2.
10/12/2012 12:02:09: P9865: Remote LDAP Server ldapserver (spatula-u5: 389): LDAP
entry for user bob did not have a password (" pass") attribute
10/12/2012 12:02:09: P9865: User bob's password does not match
10/12/2012 12:02:09: P9865: Rejecting request
10/12/2012 12:02:09: P9865: Rejecting request
10/12/2012 12:02:09: P9865: Trace of Access-Reject packet
10/12/2012 12:02:09: P9865: identifier = 10
10/12/2012 12:02:09: P9865: length = 35
10/12/2012 12:02:09: P9865: reqauth = 0d:b6:83:f9:e8:3d:a4:ad:f1:c9:33:72:91:0b:29:1c
10/12/2012 12:02:09: P9865: Reply-Message = Access Denied

```

**Note**

Remember to **reload** the Cisco Prime AR server after any changes to the LDAP server configuration.

Bind-Based Authentication for LDAP

Cisco Prime AR supports most of the LDAP servers. But, a few of the LDAP servers do not support the functionality of Cisco Prime AR, which gets the passwords from the LDAP and matches them in Cisco Prime AR.

The bind-based authentication feature in Cisco Prime AR allows you to use any LDAP server; it verifies the password in the LDAP database instead of the Cisco Prime AR database. When Cisco Prime AR receives a request, it sends the username and password to the LDAP server. The LDAP server searches for a match, and approves the request if it finds a matching user credential in its database. It rejects the request if it does not find any matching credentials.

Configuring Bind-Based Authentication for LDAP

To configure the bind-based authentication for LDAP,

Step 1 Launch **aregcmd**.

Step 2 Create an **LDAP** service.

```
[ //localhost/Radius ]
```

```
cd Services/
```

```
add ldap
```

```
cd ldap
```

```
set Type ldap
```

```
[ //localhost/Radius/Services/ldap ]
```

```

Name = ldap
Description =
Type = ldap
IncomingScript~ =
OutgoingScript~ =
OutagePolicy~ = RejectAll
OutageScript~ =
MultipleServersPolicy = Failover
RemoteServers/

```

```
cd RemoteServers
```

```
add 1 ldapserver
```

Step 3 Create the LDAP Remote Server Object.

```
[ //localhost/Radius ]
```

```
cd RemoteServers
```

```
add ldapserver
```

```
cd ldapserver
```

```
[ //localhost/Radius/RemoteServers/ldap ]
```

```
set Port <remote ldap server prt numer>
```

```
set HostName <remote ldap server name/ipaddress>
```

```
set SearchPath <configured in ldap server>
```

```
set UseBindBasedAuthentication TRUE
```

```
cd /Radius
```

```
set DefaultAuthenticationService <ldap service name>
```

```
set DefaultAuthorizationService <ldap service name>
```

Step 4 Save the configuration.

```
save
```

Step 5 Restart the application.

```
reload
```



CHAPTER 21

Using Open Database Connectivity

Cisco Prime Access Registrar (Cisco Prime AR) supports Open Database Connectivity (ODBC), an open specification that provides application developers a vendor-independent API with which to access data sources. In addition, Cisco Prime AR supports Oracle Call Interface (OCI). It provides RemoteServer objects and services to support ODBC or OCI. You can use Cisco Prime AR to authenticate and authorize access requests by querying user information through ODBC or OCI.

ODBC or OCI is an application program interface (API). Real data exchange between an application and data store is still carried out by SQL through ODBC or OCI. To achieve the most flexibility, you are required to define your own SQL using **aregcmd**. Cisco Prime AR will register the SQL statements and send them to the data store through ODBC or OCI when required. Because you can define your own SQL, Cisco Prime AR supports sites that have their own data stores.

ODBC is configured using **.ini** files, specifically **odbc.ini** and **odbcinst.ini**. However, you cannot create or modify these files directly. Cisco Prime AR creates the **.ini** files after you use **aregcmd** to configure the ODBC connection. The SQL is stored in the local database (MCD). During execution, the Cisco Prime AR server reads the local database, prepares the SQL statements, and sends the SQL to the data source.



Note

For OCI, the **.ini** files are not needed to connect to the database.



Note

Cisco Prime AR uses its own ODBC driver manager and does not share existing ODBC drivers (if you already have ODBC installed). If you are already using ODBC, you will have to maintain two separate ODBC installations.

The ODBC or OCI memory requirement depends on your configuration. The more datasources you configure, the more memory is required. Packet processing time might increase if you configure a large number of SQL statements under SQLDefinition.

The Cisco Prime AR package includes some ODBC and OCIlib Drivers, and you should use the included driver whenever possible. If a data store's ODBC driver is not included with Cisco Prime AR, you are required to install it. You configure the driver library using **aregcmd** to modify the associated **ini** file.

This chapter contains the following sections:

- [Oracle Software Requirements](#)
- [Configuring ODBC/OCI](#)
- [MySQL Support](#)

Oracle Software Requirements

The Cisco Prime AR ODBC feature requires that you have Oracle 9i and/or 10g client software installed. The OCI feature requires that you have Oracle 10g or 11g client software installed. All Oracle client software library files are expected under **\$ORACLE_HOME/lib**.

When you install Cisco Prime AR software, the installation process prompts you for ORACLE_HOME variable and sets it in the Cisco Prime AR start-up script, **/etc/init.d/arsserver**. Two other environment variables (ODBCINI and ODBCYSINI) are also set in the **arsserver** script. To change any of these variables, modify the **/etc/init.d/arsserver** script and restart the Cisco Prime AR server.

The following changes have been made to support Oracle 9 for the ODBC feature:

- The file **liboraodbc.so** has been renamed to **liboraodbc8.so**.
- The file **liboraodbc9.so** has been added.



Note

Install the Oracle 10g client for Solaris and Linux using 10gr2_client_sol.cpio.gz, instantclient-basic-solaris32-10.1.0.5-20060502.zip, 10201_client_linux32.zip, and instantclient-basic-linux32-10.1.0.5-20060511.zip respectively.



Note

For OCI services, ensure that you have installed the Oracle client properly by using tnsping or sqlplus utilities.

Configuring ODBC/OCI

You use **aregcmd** to define your ODBC configuration and SQL statements. The Cisco Prime AR server automatically creates the **ODBC.ini** file for your driver manager and driver based on how you configure ODBC.

Configuring the ODBC and ODBC-Accounting Remote Servers

To use ODBC in Cisco Prime AR for AA:

-
- Step 1** Configure an ODBC DataSource.
 - Step 2** Configure an ODBC RemoteServer object with protocol type as 'odbc'.
 - Step 3** Configure an ODBC Service with service type as 'odbc'.
 - Step 4** Set ODBC service as the DefaultAuthenticationService and DefaultAuthorizationService.
 - Step 5** Save your configuration.
-

To use ODBC in Cisco Prime AR for Accounting:

-
- Step 1** Configure an ODBC DataSource.
 - Step 2** Configure an ODBC RemoteServer object with protocol type as 'odbc-account'.
 - Step 3** Configure an ODBC Service with service type as 'odbc-accounting'.
 - Step 4** Set ODBC service as the DefaultAccountingService.
 - Step 5** Save your configuration.
-

After you **save** and validate your configuration, it is saved in the MCD database. If you have configured an ODBC service, Cisco Prime AR will query the MCD database and create or modify the **odbc.ini** file before it builds a connection to the database. When you reload your configuration, Cisco Prime AR shuts down any existing ODBC connections, then queries the MCD database to create or modify the **odbc.ini** file and build a new connection for any configured ODBC Data Sources.

The following shows an example configuration for AA remote server:

```
[ //localhost/Radius/RemoteServers/oracle-access ]
Name = oracle-access
Description =
Protocol = odbc
ReactivateTimerInterval = 300000
Timeout = 15
DataSourceConnections = 8
ODBCDataSource = gordon
SNMPTrapIP =
SNMPTrapPort = 1521
KeepAliveTimerInterval = 0
SQLDefinition/
UserPasswordAttribute = password
SQLStatements/
Entries 1 to 1 from 1 total entries
Current filter: <all>

sql1/
  Name = sql1
  Description =
  Type = query
  SQL = "select password , username from arusers where username = ?"
  ExecutionSequenceNumber = 1
  MarkerList = UserName/SQL_CHAR
ODBCToRadiusMappings/
ODBCToEnvironmentMappings/
ODBCToCheckItemMappings/
```

The following shows an example configuration for AAA remote server:

```
[ //localhost/Radius/RemoteServers/ora_acc ]
Name = ora_acc
Description =
Protocol = odbc-accounting
ReactivateTimerInterval = 1000
Timeout = 15
DataSourceConnections = 8
ODBCDataSource = gordon
SNMPTrapIP =
SNMPTrapPort = 1521
KeepAliveTimerInterval = 1000
BufferAccountingPackets = TRUE
```

```

MaximumBufferSize = "10 Megabytes"
NumberOfRetriesForBufferedPacket = 3
BackingStoreEnvironmentVariables =
UseLocalTimeZone = FALSE
AttributeList =
Delimiter =
SQLDefinition/
SQLStatements/
Entries 1 to 1 from 1 total entries
Current filter: <all>

sql/
Name = sql
Description =
Type = insert
SQL = "insert into accounting(username,acct_status_type) values ( ? , ? )"
ExecutionSequenceNumber = 1
MarkerList = "UserName/SQL_CHAR Acct-Status-Type/SQL_CHAR "

```

You use **aregcmd** to define your OCI configuration and SQL statements.

Configuring an OCI and OCI-Accounting Remote Servers

To use OCI in Cisco Prime AR for AA:

-
- Step 1** Configure the DataSource type as oracle_oci.
 - Step 2** Configure an OCI RemoteServer object protocol type as 'oci'.
 - Step 3** Configure an OCI Service with type as 'oci'.
 - Step 4** Set OCI service as the DefaultAuthenticationService and DefaultAuthorizationService.
 - Step 5** Save your configuration.
-

To use OCI in Cisco Prime AR for Accounting:

-
- Step 1** Configure the DataSource type as oracle_oci.
 - Step 2** Configure an OCI RemoteServer object protocol type as 'oci-accounting'.
 - Step 3** Configure an OCI Service with type as 'oci-accounting'.
 - Step 4** Set OCI service as the DefaultAccountingService.
 - Step 5** Save your configuration .
-

After you **save** and validate your configuration, it is saved in the MCD database.

The following shows an example configuration for AA remote server:

```

[ //localhost/Radius/RemoteServers/oracle-access ]
Name = oracle-access
Description =
Protocol = oci
ReactivateTimerInterval = 300000
Timeout = 15
DataSourceConnections = 8
ODBCDataSource = gordon
SNMPTrapIP =

```

```

SNMPTrapPort = 1521
KeepAliveTimerInterval = 0
SQLDefinition/
UserPasswordAttribute = password
SQLStatements/
Entries 1 to 1 from 1 total entries
Current filter: <all>

sql1/
  Name = sql1
  Description =
  Type = query
  SQL = "select password , username from arusers where username = ?"
  ExecutionSequenceNumber = 1
  MarkerList = UserName/SQL_CHAR
  OCIToRadiusMappings/
  OCIToEnvironmentMappings/
  OCIToCheckItemMappings/

```

The following shows an example configuration for AAA remote server:

```

[ //localhost/Radius/RemoteServers/ora_acc ]
Name = ora_acc
Description =
Protocol = oci-accounting
ReactivateTimerInterval = 1000
Timeout = 15
DataSourceConnections = 8
ODBCDataSource = gordon
SNMPTrapIP =
SNMPTrapPort = 1521
KeepAliveTimerInterval = 1000
BufferAccountingPackets = TRUE
MaximumBufferFileSize = "10 Megabytes"
NumberOfRetriesForBufferedPacket = 3
BackingStoreEnvironmentVariables =
UseLocalTimeZone = FALSE
AttributeList =
Delimiter =
SQLDefinition/
SQLStatements/
Entries 1 to 1 from 1 total entries
Current filter: <all>

sql/
  Name = sql
  Description =
  Type = insert
  SQL = "insert into accounting(username,acct_status_type) values ( ? , ? )"
  ExecutionSequenceNumber = 1
  MarkerList = "UserName/SQL_CHAR Acct-Status-Type/SQL_CHAR "

```

This section contains the following topics:

- [Configuring an ODBC/OCI Service](#)
- [Configuring an ODBC/OCI RemoteServer](#)
- [Configuring an ODBC DataSource](#)
- [Setting ODBC/OCI As Authentication and Authorization Service](#)
- [Setting ODBC/OCI As Accounting Service](#)
- [Saving Your Configuration](#)
- [Oracle Stored Procedures](#)

Configuring an ODBC/OCI Service

You configure an ODBC or OCI service under **/Radius/Services**. When you define an ODBC or OCI service under **/Radius/Services**, you must set its type to ODBC or OCI and provide the following configuration options:

Note

We will use ODBC or OCI as the ODBC or OCI service name in the following examples.

Example configuration for ODBC

```
[ //localhost/Radius/Services/ODBC ]
  Name = ODBC
  Description =
  Type = odbc
  IncomingScript~ =
  OutgoingScript~ =
  OutagePolicy~ = RejectAll
  OutageScript~ =
  MultipleServersPolicy = Failover
  RemoteServers/
```

Example configuration for OCI

```
[ //localhost/Radius/Services/OCI ]
  Name = OCI
  Description =
  Type = oci
  IncomingScript~ =
  OutgoingScript~ =
  OutagePolicy~ = RejectAll
  OutageScript~ =
  MultipleServersPolicy = Failover
  RemoteServers/
```

Table 21-1 describes the ODBC or OCI service parameters.

Table 21-1 ODBC/OCI Service Parameters

Parameter	Description
Name	Required; inherited from the upper directory
Description	An optional description of the service
Type	Must be set to ODBC for ODBC service or OCI for OCI service
IncomingScript	Optional
OutgoingScript	Optional
OutagePolicy	Required; must be set to AcceptAll or Drop Packet, or defaults to RejectAll
OutageScript	Optional

Table 21-1 ODBC/OCI Service Parameters (continued)

Parameter	Description
MultipleServersPolicy	Required; must be set to RoundRobin or defaults to Failover. When set to Failover, Cisco Prime AR directs requests to the first server in the list until it determines the server is offline. If so, Cisco Prime AR redirects all requests to the next server in the list until it finds an online server. When set to RoundRobin, Cisco Prime AR directs each request to the next server in the RemoteServers list to share the resource load across all servers in the RemoteServers list.
RemoteServers	Required list of remote servers defined under /Radius/Services/ODBC/RemoteServers such as ODBC-Primary and ODBC-Secondary

Configuring an ODBC/OCI RemoteServer

Configuring an ODBC Remote Server

You must configure an ODBC RemoteServer object for each RemoteServer object you list under **/Radius/Services/ODBC/RemoteServers**. Use the **aregcmd** command **add** to add ODBC servers under **/Radius/RemoteServers**.

Configuring an OCI Remote Server



You must configure an OCI RemoteServer object for each RemoteServer object you list under **/Radius/Services/OCI/RemoteServers**. Use the **aregcmd** command **add** to add OCI servers under **/Radius/RemoteServers**.

[Table 21-2](#) describes the ODBC or OCI service parameters. The fields that are displayed in the table changes based on the protocol type selected.

Table 21-2 ODBC/OCI Remote Server Parameters

Parameter	Description
Name	Required; inherited from the upper directory
Description	An optional description of the server
Protocol	Required and must be set to ODBC or OCI for ODBC or OCI service respectively; no default value
ReactivateTimerInterval	Required; default is 300000 (ms)
Timeout	Required; default is 15 (seconds)
DataSourceConnections	Required; number of concurrent connections to data source (default is 8)
ODBCDataSource	Required; no default value

Table 21-2 ODBC/OCI Remote Server Parameters (continued)

Parameter	Description
SQLDefinition	<p>SQLDefinition/ (mandatory, no default); UserPasswordAttribute = (mandatory, no default; data store field for user password)</p> <p>SQLStatements/ SQLStatement1/ SQLStatement2/</p>
ODBCToRadiusMappings (OCIToRadiusMappings)	<p>Optional; a list of name/value pairs in which the name is the name of the odbc attribute to retrieve from the user record, and the value is the name of the RADIUS attribute to set to the value of the odbc attribute retrieved.</p> <p>For example, when the ODBCToRadiusMappings has the entry: FramedIPAddress = Framed-IP-Address, the RemoteServer retrieves the FramedIPAddress attribute from the odbc user entry for the specified user, uses the value returned, and sets the Response variable Framed-IP-Address to that value.</p> <p> Note When you select the protocol as OCI, the field name will be displayed as OCIToRadiusMappings.</p>
ODBCToEnvironmentMappings (OCIToEnvironmentMappings)	<p>Optional; a list of name/value pairs in which the name is the name of the odbc attribute to retrieve from the user record, and the value is the name of the Environment variable to set to the value of the odbc attribute retrieved.</p> <p>For example, when the ODBCToEnvironmentMappings has the entry: group = User-Group, the RemoteServer retrieves the group attribute from the odbc user entry for the specified user, uses the value returned, and sets the Environment variable User-Group to that value.</p> <p> Note When you select the protocol as OCI, the field name will be displayed as OCIToEnvironmentMappings.</p>
ODBCToCheckItemMappings (OCIToCheckItemMappings)	<p>Optional; a list of ODBC <i>attribute/value</i> pairs which must be present in the RADIUS access request and must match, both name and value, for the check to pass.</p> <p>For example, when the ODBCToCheckItemMappings has the entry: group = User-Group, the Access Request must contain the attribute group, and it must be set to User-Group.</p> <p> Note When you select the protocol as OCI, the field name will be displayed as OCIToCheckItemMappings.</p>

ODBC Data Source

ODBCDataSource is the name of the datasource to be used by the remote server. An ODBCDataSource name can be reused by multiple remote servers. You configure ODBCDataSources under **/Radius/Advanced/ODBCDataSources**. See [Configuring an ODBC DataSource, page 21-11](#), for more information.

Tuning \$ORACLE_HOME/network/admin/sqlnet.ora file on the Oracle Client

For proper function of the reactivate timer interval, one or more of the following parameters in sqlnet.ora file needs to be tuned:

- SQLNET.INBOUND_CONNECT_TIMEOUT
- SQLNET.SEND_TIMEOUT
- SQLNET.RECV_TIMEOUT

Ensure that the ReactivateTimerInterval of ODBC/ODBC-Accounting remoteservers should be greater than the timeout values configured in sqlnet.ora.

SQL Definitions

SQLDefinitions lists the UserPasswordAttribute and one or more SQL statements, listed numerically in the order to be run. The UserPasswordAttribute represents a column in the database that contains users' password information. Individual SQLStatements are numbered SQL1 through SQLn under SQLStatements, as shown in the following example:

```
SQLDefinition/
  UserPasswordAttribute = asdfjkl
  SQLStatements/
    SQL1/
    SQL2/
    SQL3/
    ...
```

The following example is an SQL statement used for Authentication and Authorization:

```
SQLStatements/
  SQL1
    Name = SQL1
    Type = query (mandatory, no default; must be query/procedure)
    SQL = SQL statement (mandatory, no default)
    ExecutionSequenceNumber = Sequence number for SQLStatement execution.(mandatory,
    no default and must be greater than zero).
    MarkerList = UserName/SQL_DATA_TYPE ..... (mandatory, UserName must be defined)
```

For more information on stored procedures and stored functions, refer [Oracle Stored Procedures, page 21-13](#).

[Table 21-3](#) describes the SQL Statement parameters.

Table 21-3 SQL Statement Parameters

Parameter	Description
Name	Name/number of SQL statement
Type	Query (mandatory, no default value)
SQL	SQL query statement

Table 21-3 SQL Statement Parameters (continued)

Parameter	Description
ExecutionSequenceNumber	Sequence number for SQLStatement execution, must be greater than zero (mandatory, no default)
MarkerList	Defines all markers for the query. MarkerList uses the format <i>UserName/SQL_DATA_TYPE</i> .

SQL Syntax Restrictions

You must observe the following SQL syntax restrictions in SQL queries for Cisco Prime AR.

1. The SQL statement must be in the format of SELECT ... FROM ... WHERE ... (Statements might be in lowercase.)



Note 'WHERE' is compulsory in the SQL statement.

2. Stored procedures with return value must be in the "begin ? := <Stored_procedure_name> (<IN/OUT Parameters>); end;" format.
3. Stored procedures without return value can be in the "CALL <Stored_procedure_name> (<IN/OUT Parameters>)" format.
4. Any arguments to Oracle functions like *distinct*, *count* must be given within braces, as shown in the following example:

```
select distinct(attribute),password from profiles where username=?
```

The resulted column from *distinct(attribute)* will be put into *attribute* which can be used for ODBC Mappings. The actual result set from Oracle for this column would be named *distinct(attribute)*.

5. The column list in the SQL statement must be delimited with a comma (,) and any extra spaces between statements are ignored. Aliasing for column names in SQL is not allowed. SQLDefinition properties define the SQL you want to execute, as shown in the following example.

Specifying More Than One Search Key

You can specify more than one search key for a table in the SQL SELECT. To do so, add another search criteria to the SQL statement and add the environment variable name to the MarkerList. For example, the following query and MarkerList can be used to look up a username and CLID match.

```
select password from user_table where username = ? and clid = ?
```

In this case, the marker list would look like this:

```
UserName/SQL_CHAR clid/SQL_CHAR
```

To configure the multiple entries in the MarkerList list, surround the entire string in double quotes like the following:

```
set MarkerList "UserName/SQL_CHAR CLID/SQL_CHAR"
```

To make this work, a variable called CLID must be in the environment dictionary. You can use a script to copy the appropriate value into the variable.

ODBCToRadiusMappings/OCIToRadiusMappings

You configure ODBCToRadiusMappings or OCIToRadiusMappings with a list of *name/value* pairs where name is the name of the data store attribute to retrieve from the user record and the value is the name of the RADIUS attribute to set to the value of the data store attribute retrieved.

For example, use the following **aregcmd** command to set a value for the variable *Framed-IP-Address*:

```
set FramedIPAddress Framed-IP-Address
```

When the ODBCToRadiusMappings or OCIToRadiusMappings has this entry, the RemoteServer retrieves the attribute from the data store user entry for the specified user, uses the value returned, and sets the response variable *Framed-IP-Address* to that value.

When an SQL select statement returns more than one row for a column mapped under ODBCToRadiusMappings or OCIToRadiusMappings, multiple Radius attributes are created.

For example, consider the following SQL *select* statement with ciscoavpair configured to Cisco-AVPair under ODBCToRadiusMappings. The table.column syntax requires an SQL alias for the mapping to work, as shown in the following example:

```
SQLStatements/
  SQL1/
    select table1.abc as t1abc, password from table2 where username = ?
    Mapping: t1abc = my_mapping
```

If two rows are returned for ciscoavpair column, two Cisco-AVPair attributes will be created.

ODBCToEnvironmentMappings/OCIToEnvironmentMappings

Under ODBCToEnvironmentMappings or OCIToEnvironmentMappings there is a list of name and value pairs in which the name is the name of the data store attribute to retrieve from the user record, and the value is the name of the Environment variable to set to the value of the ODBC or OCI attribute retrieved.

For example, when the ODBCToEnvironmentMappings has the entry: group =User-Group, the RemoteServer retrieves the attribute from the ODBC user entry for the specified user, uses the value returned, and sets the environment variable User-Group to that value. When an SQL select statement returns more than one row for a column mapped under ODBCToEnvironmentMappings, the value for all rows is concatenated and assigned to the environment variable.

ODBCToCheckItemMappings/OCIToCheckItemMappings

A list of ODBC or OCI *attribute/value* pairs which must be present in the RADIUS access request and must match, both name and value, for the check to pass.

For example, when the **ODBCToCheckItemMappings** or **OCIToCheckItemMappings** has the entry: **group = User-Group**, the Access Request must contain the attribute **group**, and it must be set to **User-Group**.

Configuring an ODBC DataSource

ODBCDataSource is the name of the datasource to be used by the remote server. You configure ODBCDataSources under **/Radius/Advanced/ODBCDataSources**. Multiple remote servers can use the same ODBCDataSource.

Under the ODBCDataSource object definition, for ODBC a list defines **ODBC.ini** filename/value pairs for a connection. The list includes a Type field and a Driver field, different for each Driver and Data Source, to indicate its Driver and Data Source. Cisco Prime AR currently supports only the Easysoft Open Source Oracle Driver.

For OCI services, ODBCDataSource type should be 'oracle_oci'. The following is an example configuration of ODBCDataSource for OCI services.

```
[ //localhost/Radius/Advanced/ODBCDataSources/gordon ]
Name = gordon
Description =
Type = oracle_oci
UserID = scott
Password = <encrypted>
DataBase = orcl.cisco.com
```

Table 21-4 describes the Easysoft Open Source Oracle Driver options for ODBC.

Table 21-4 Easysoft Open Source Oracle Driver Options for ODBC

Parameter	Description
Name	Name of the ODBCDataSource
Type	Required; must be Oracle_es
Driver	Required; liboarodbc.so (default value)
Database	Required; Oracle Client configuration database name (no default value)
UserID	Required; database username (no default value)
Password	Optional user password; shown encrypted

Table 21-5 describes the OCILib Open Source Oracle Driver options for OCI.

Table 21-5 OCILib Open Source Oracle Driver Options for OCI

Parameter	Description
Name	Name of the ODBCDataSource
Type	Required; must be Oracle_oci
Database	Required; Oracle Client configuration database name (no default value)
UserID	Required; database username (no default value)
Password	Optional user password; shown encrypted

Setting ODBC/OCI As Authentication and Authorization Service

Use **aregcmd** to configure the ODBC Service as the default authentication and authorization service under **//localhost/Radius** as in the following:

```
set DefaultAuthenticationService odbc-service
```

```
set DefaultAuthorizationService odbc-service
```

Use **aregcmd** to configure the OCI Service as the default authentication and authorization service under **//localhost /Radius** as in the following:

```
set DefaultAuthenticationService oci-service
```

```
set DefaultAuthorizationService oci-service
```

**Note**

When you use an ODBC or OCI service, configure the **BackingStoreDiscThreshold** property under **/Radius/Advanced** to ensure that the data generated by log files do not exceed the size limit configured.

Setting ODBC/OCI As Accounting Service

Use **aregcmd** to configure the ODBC Service as the default accounting service under **//localhost /Radius** as in the following:

```
set DefaultAccountingService odbc-service
```

Use **aregcmd** to configure the OCI Service as the default authentication and authorization service under **//localhost /Radius** as in the following:

```
set set DefaultAccountingService oci-service
```

Saving Your Configuration

When you use **aregcmd** to **save** your configuration, Cisco Prime AR attempts to validate the configuration, checks for all required parameters, and ensures there is no logic error. If the validation is successful, the configuration is saved to the MCD database. When you **reload**, Cisco Prime AR shuts down any current ODBC/OCI connections and builds new connections for the configured ODBC Data Sources.

Oracle Stored Procedures

A stored procedure is a database procedure similar to other programming language procedures, which is contained within the database itself. A SQL Server stored procedure that contains one or more IN parameters are used to pass data into the stored procedure. Similarly, one or more OUT parameters in the stored procedure are used to return data back to the calling application. Cisco Prime AR supports Oracle stored procedures/functions with IN and OUT parameters only over the OCI interface.

For Authentication and Authorization, Cisco Prime AR supports both Stored Procedures and Stored Functions with the In/Out parameters and return value. In the configuration for the AA remote server, the **UserPasswordAttribute** value must be in the marker list for procedures.

For Accounting, Cisco Prime AR supports both Stored Procedures and Stored Functions with only the In parameters, and does not support return value and Out parameters.

The following are the examples for stored functions and procedures calling inside Cisco Prime AR:

Example format for stored functions with return value
SQL = "begin ? := stress (?);end;"

Example for stored procedures
SQL = " CALL Accounting_Request(?,?,?)"

Note

Cisco Prime AR does not support, return value with the "call" format for the stored procedures.

The following shows an example configuration for OCI AA remote server:

```
[ //localhost/Radius/RemoteServers ]
Entries 1 to 2 from 2 total entries
Current filter: <all>

oci-access/
  Name = oci-access
  Description =
  Protocol = oci
  ReactivateTimerInterval = 300000
  Timeout = 15
  DataSourceConnections = 8
  ODBCDataSource = 54
  SNMPTrapIP = 10.77.240.57
  SNMPTrapPort = 1521
  KeepAliveTimerInterval = 0
  SQLDefinition/
  UserPasswordAttribute = password
  SQLStatements/
  Entries 1 to 1 from 1 total entries
  Current filter: <all>

  sql1/
    Name = sql1
    Description =
    Type = procedure
    SQL = "begin ? := stress (?);end;"
    ExecutionSequenceNumber = 1
    MarkerList = "password/SQL_OUT UserName/SQL_CHAR"
  OCIToRadiusMappings/
  OCIToEnvironmentMappings/
  OCIToCheckItemMappings/
```

The following shows an example configuration for OCI AA remote server:

```
oci-acc/
  Name = oci-acc
  Description =
  Protocol = oci-accounting
  ReactivateTimerInterval = 300000
  Timeout = 15
  DataSourceConnections = 8
  ODBCDataSource = 54
  SNMPTrapIP =
  SNMPTrapPort = 1521
  KeepAliveTimerInterval = 0
  BufferAccountingPackets = TRUE
  MaximumBufferFileSize = "10 Megabytes"
  NumberOfRetriesForBufferedPacket = 3
  BackingStoreEnvironmentVariables =
  UseLocalTimeZone = FALSE
```

```

AttributeList =
Delimiter =
SQLDefinition/
UserPasswordAttribute =
SQLStatements/
Entries 1 to 1 from 1 total entries
Current filter: <all>

sql/
Name = sql
Description =
Type = procedure
SQL = " CALL Accounting_Request( ?,?,?)"
ExecutionSequenceNumber = 1
MarkerList = "UserName/SQL_CHAR Acct-Status-Type/SQL_CHAR Calling-Station-Id/SQL_CHAR "

```

**Note**

Cisco Prime AR supports Oracle stored procedures for OCI AA and OCI AAA remote servers.

MySQL Support

Cisco Prime AR provides support for MySQL to query user records from a MySQL database and enables you to write accounting records into MySQL when using Oracle accounting. Cisco Prime AR has been tested with MySQL 5.0.90 and MyODBC 3.51.27 (reentrant).

This section contains the following topics:

- [MySQL Driver](#)
- [Configuring a MySQL Datasource](#)
- [Example Configuration](#)

MySQL Driver

You can download the MySQL driver from the MySQL website at <http://mysql.com>. You can go directly to the driver download page using the following URL:

<http://dev.mysql.com/downloads/connector/odbc/3.51.html>

Save the downloaded file to a temporary location such as **/tmp**. Use commands like the following to unzip and install the driver:

```

gunzip -c mysql-connector-odbc-3.51.27-solaris10-sparc-32bit.pkg.gz
pkgadd -d /tmp mysql-connector-odbc-3.51.27-solaris10-sparc-32bit.pkg
ln -s mysql-connector-odbc-3.51.27-solaris10-sparc-32bit myodbc

```

Configuring a MySQL Datasource

You require the following to configure a MySQL Datasource:

- ODBCDataSource object
- RemoteServer object

- ODBC service
- Default AA services

Configuring a MYSQL datasource

To configure the Cisco Prime AR server to query records from a MySQL database:

Step 1 Log in to the Cisco Prime AR server and launch **aregcmd**.

Log in as a user with administrative rights such as user **admin**.

Step 2 Change directory to the **/Radius/Advanced/ODBCDataSources** and add a new ODBCDataSource.

```
cd /Radius/Advanced/ODBCDataSources
```

```
add mysql
```

Step 3 Set the new ODBCDataSource type to myodbc.

```
cd mysql
```

```
[ //localhost/Radius/Advanced/ODBCDataSources/mysql ]
  Name = mysql
  Description =
  Type =
```

```
set type myodbc
```

The following is the default configuration for an ODBCDataSource object of type myodbc:

```
[ //localhost/Radius/Advanced/ODBCDataSources/mysql ]
  Name = mysql
  Description =
  Type = myodbc
  Driver =
  UserID =
  Password =
  DataBase =
  Server =
  Port = 3306
```

Step 4 Set the Driver property to the path of the MyODBC library. Use a command like the following:

```
set driver /scratch/myodbc/libmyodbc3_r.so
```

Step 5 Set the UserID property to a valid username for the MyODBC database and provide a valid password for this user.

```
set userid ar-mysql-user
```

```
set password biscuit
```

Step 6 Provide a DataBase name and the name of the Cisco Prime AR RemoteServer object to associate with the ODBCDataSource.

```
set database database_name
```

```
set server remote_server_name
```

- Step 7** Change directory to **/Radius/RemoteServers** and add a RemoteServer object to associate with the new ODBCDataSource.
- ```
cd /Radius/RemoteServers

add mysql
```
- Step 8** Change directory to the new RemoteServer and set its protocol to odbc.
- ```
cd mysql

set protocol odbc
```
- Step 9** Set the ODBCDataSource property to the name of the ODBCDataSource to associate with this RemoteServer object.
- ```
set ODBCDataSource mysql
```
- Step 10** Change directory to **/Radius/Services** and add an ODBC service as described in [Configuring an ODBC/OCI Service, page 21-6](#).
- Step 11** Change directory to **/Radius** and set the DefaultAuthenticationService and DefaultAuthorizationService properties to the ODBC service added in the previous step.

## Example Configuration

The following shows an example configuration for a MySQL ODBC data source. See [Configuring an ODBC DataSource, page 21-11](#) for more information.

```
[//localhost/Radius/Advanced/ODBCDataSources/mysql]
Name = mysql
Type = myodbc
Driver = /tmp/libmyodbc3_r.so
UserID = mysql
Password = <encrypted>
DataBase = test
Server = mysql-a
Port = 3306
```

The following shows an example configuration for a RemoteServer. See [Configuring an ODBC/OCI RemoteServer, page 21-7](#) for more information.

```
[//localhost/Radius/RemoteServers/mysql-a]
Name = mysql
Description =
Protocol = odbc
ReactivateTimerInterval = 300000
Timeout = 15
DataSourceConnections = 8
ODBCDataSource = mysql
KeepAliveTimerInterval = 0
SQLDefinition/
UserPasswordAttribute = asdfjkl
SQLStatements/
 SQL1/
 Name = SQL1
 Type = query (mandatory, no default; must be query)
 SQL = SQL statement (mandatory, no default)
```

```
ExecutionSequenceNumber = Sequence number for SQLStatement
execution.(mandatory, no default and must be greater than zero).
MarkerList = UserName/SQL_DATA_TYPE (mandatory, UserName must be defined)
SQL2/
SQL3/
ODBCToRadiusMappings/
ODBCToEnvironmentMappings/
ODBCToCheckItemMappings/
```

The following shows an example configuration for an ODBC service. See [Configuring an ODBC/OCI Service, page 21-6](#) for more information.

```
[//localhost/Radius/Services/ODBC]
Name = ODBC
Description =
Type = ODBC
IncomingScript~ =
OutgoingScript~ =
OutagePolicy~ = RejectAll
OutageScript~ =
MultipleServersPolicy = Failover
RemoteServers/
1. mysql-a
```

The following shows an example configuration where the DefaultAuthenticationService and DefaultAuthorizationService properties have been set to the ODBC service.

```
[//localhost/Radius]
Name = Radius
Description =
Version = 5.1
IncomingScript~ =
OutgoingScript~ =
DefaultAuthenticationService~ = ODBC
DefaultAuthorizationService~ = ODBC
```



# CHAPTER 22

## SIGTRAN-M3UA

SIGTRAN, a working group of the Internet Engineering Task Force (IETF), has defined a protocol for the transport of real-time signaling data over IP networks. Cisco Prime AR supports SS7 messaging over IP (SS7oIP) via SIGTRAN-M3UA, a new transport layer which leverages Stream Control Transmission Protocol (SCTP). Cisco Prime AR supports SIGTRAN-M3UA to fetch the authentication vectors from HLR, which is required for EAP-AKA/EAP-SIM authentication.



**Note**

You have SIGTRAN-M3UA interface support in addition to the existing SUA interface support.

The EAP-AKA and EAP-SIM authentication service is extended to use M3UA. When using M3UA service for authentication, the subscriber identity (IMSI) is used to send a request to HLR and receives information from HLR containing the authentication information for authenticating an user. The authentication service initiates a request to the SIGTRAN server using IMSI, which retrieves the configured number of authentication vectors from HLR, i.e Triplets or Quintets.



**Note**

When you install SIGTRAN-M3UA remote server for the first time or update the existing installation, you need to update the ip address of Cisco Prime AR where it is been installed in *network.data* and *cli\_client.conf* files. Also, you must restart Cisco Prime AR to have the changes reflected.

If the LocalSubSystemNumber is not set as SGSN(149), you need to make the same change in the *default.xml* file, located at */cisco-ar/m3ua-cfg/*.

**Figure 22-1** MAP Service

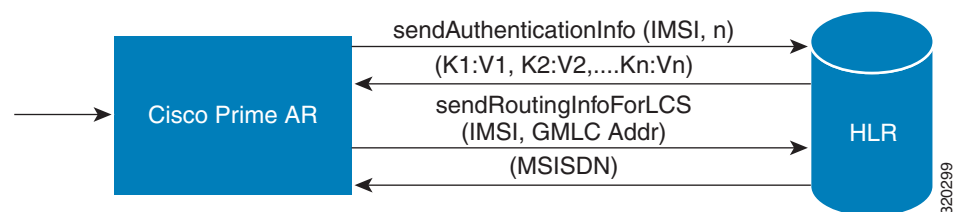

The Cisco Prime AR server initiates the MAP service. After enabling the MAP service, the Cisco Prime AR server sends a `sendAuthenticationInfo` request that contains IMSI and the number of requested authentication vectors to HLR. The HLR sends a response containing the requested vectors information

to Cisco Prime AR. Next, the Cisco Prime AR server sends a `sendRoutinginfoForLCS` request that contains IMSI and the GMLC address to HLR. The HLR sends a response containing the MSISDN information for authenticating the mobile subscribers.

**Note**

---

Cisco Prime AR 6.0 supports only one remote server with the protocol type, SIGTRAN-M3UA.

---

This section describes the following:

- [Prerequisites to SIGTRAN-M3UA](#)
- [Configuring EAP-AKA/EAP-SIM with SIGTRAN-M3UA](#)
- [Configuring M3UA Service](#)

## Prerequisites to SIGTRAN-M3UA

Before enabling the SIGTRAN-M3UA remote server, you must do the following:

- ensure that LKSCTP is not available in the Cisco Prime AR server.
- ensure to restart the Cisco Prime AR server whenever you make any configuration changes.
- ensure that the following rpm files are not installed while installing the Cisco Prime AR in RHEL 6.2:
  - `nss-softokn-freebl-3.12.9-11.el6.i686.rpm`
  - `glibc-2.12-1.47.el6.i686.rpm`
  - `ncurses-libs-5.7-3.20090208.el6.i686.rpm`
  - `ncurses-devel-5.7-3.20090208.el6.i686.rpm`
  - `ncurses-5.7-3.20090208.el6.i686.rpm`
  - `nspr-4.8.8-3.el6.i686.rpm`
  - `nss-util-3.12.10-2.el6.i686.rpm`
- ensure that the following rpm files are installed while installing the Cisco Prime AR in RHEL 6.2:
  - `nss-softokn-freebl-3.12.9-11.el6.i686.rpm`
  - `glibc-2.12-1.47.el6.i686.rpm`
  - `ncurses-libs-5.7-3.20090208.el6.i686.rpm`
  - `ncurses-devel-5.7-3.20090208.el6.i686.rpm`
  - `ncurses-5.7-3.20090208.el6.i686.rpm`
  - `nspr-4.8.8-3.el6.i686.rpm`
  - `nss-util-3.12.10-2.el6.i686.rpm`
  - `gamin-0.1.10-9.el6.i686.rpm`
  - `libselinux-2.0.94-5.2.el6.i686.rpm`
  - `glib2-2.22.5-6.el6.i686.rpm`
  - `zlib-1.2.3-27.el6.i686.rpm`
  - `libxml2-2.7.6-4.el6.i686.rpm`
  - `gdome2-0.8.1-1.i386.rpm`
  - `glib-1.2.10-33.el6.i686.rpm`

- libgcc-4.4.6-3.el6.i686.rpm
- libstdc++-4.4.6-3.el6.i686.rpm



**Note** You must install the rpm versions relevant to the RHEL OS versions while installing the Cisco Prime AR.

## Configuring EAP-AKA/EAP-SIM with SIGTRAN-M3UA

You can use `aregcmd` to create and configure the service of type `eap-aka` or `eap-sim`, see [EAP-AKA](#) or [EAP-SIM](#) for more information.

To configure EAP-AKA service with SIGTRAN-M3UA remote server:

- 
- Step 1** Launch `aregcmd`.
- Step 2** Create an EAP-AKA service.
- ```
cd /Radius/Services

add eap-aka-service
```
- Step 3** Set type as `eap-aka`.
- ```
set eap-aka
```
- Step 4** Add `m3ua` remote server in the `remoteServers`
- ```
cd remoteServers/

Set 1 m3ua
```
-

The following shows an example configuration for EAP-AKA service with SIGTRAN-M3UA remote server support, see [Table 9-1](#) to know more about EAP-AKA service properties.

```
[ //localhost/Radius/Services ]
  Entries 1 to 2 from 2 total entries
  Current filter: <all>

  eap-aka/
    Name = eap-aka
    Description =
    Type = eap-aka
    AlwaysRequestIdentity = False
    EnableIdentityPrivacy = False
    PseudonymSecret = <encrypted>
    PseudonymRenewtime = "24 Hours"
    PseudonymLifetime = Forever
    Generate3GPPCompliantPseudonym = False
    EnableReauthentication = False
    MaximumReauthentications = 16
    ReauthenticationTimeout = 3600
    ReauthenticationRealm =
```

```

AuthenticationTimeout = 120
QuintetGenerationScript~ =
UseProtectedResults = False
SendReAuthIDInAccept = False
Subscriber_DBLookup = sigTRAN-m3UA
FetchAuthorizationInfo = FALSE
MultipleServersPolicy = Failover
IncomingScript~ =
OutgoingScript~ =
OutageScript~ =
RemoteServers/

```

To configure EAP-SIM service with SIGTRAN-M3UA remote server:

-
- Step 1** Launch **aregcmd**.
- Step 2** Create an EAP-SIM service.
- ```

cd /Radius/Services

add eap-sim-service

```
- Step 3** Set type as eap-sim.
- ```

set eap-sim

```
- Step 4** Add m3ua remote server in the remoteServers
- ```

cd remoteServers

Set 1 m3ua

```
- 

The following shows an example configuration for EAP-SIM service with SIGTRAN-M3UA remote server support, see [Table 9-6](#) to know more about EAP-SIM service properties.

```

eap-sim/
Name = eap-sim
Description =
Type = eap-sim
NumberOfTriplets = 2
UseSimDemoTriplets = False
AlwaysRequestIdentity = False
EnableIdentityPrivacy = False
PseudonymSecret = <encrypted>
PseudonymRenewtime = "24 Hours"
PseudonymLifetime = Forever
Generate3GPPCompliantPseudonym = False
EnableReauthentication = False
MaximumReauthentications = 16
ReauthenticationTimeout = 3600
ReauthenticationRealm =
TripletCacheTimeout = 0
AuthenticationTimeout = 120
UseProtectedResults = False
SendReAuthIDInAccept = False
SubscriberDBLookup = SigTRAN-M3UA
FetchAuthorizationInfo = FALSE
MultipleServersPolicy = Failover
IncomingScript~ =

```

```
OutgoingScript~ =
OutageScript~ =
RemoteServers/
```



**Note** Before enabling the SIGTRAN-M3UA remote server, you must ensure to restart the Cisco Prime AR server whenever you make any configuration changes.



**Note** If you set `FetchAuthorizationInfo` as `TRUE` for EAP-AKA or EAP-SIM service for SIGTRAN-M3UA in Cisco Prime AR, it fetches the MSISDN information from HLR in response. The following is an example script for reading the MSISDN information from the response,

```
proc MapMSISDN {request response environ} {
$environ get AuthorizationInfo
}
```

You can configure the SIGTRAN-M3UA remoteserver under **/Radius/RemoteServers**.

To configure the SIGTRAN-M3UA remote server:

- 
- Step 1** Launch `aregcmd`.
- Step 2** Create `sigtran-m3ua` remote server.
- ```
cd /r/remoteservers/
add M3UA
cd M3UA
set protocol sigtran-m3ua
```
- Step 3** Set the `Subscriber_DBLookup`.
- ```
set Subscriber_DBLookup SIGTRAN-M3UA
```
- Step 4** Set the hostname and port of the HLR.
- ```
set hostName 10.81.78.140
set DestinationPort 2905
```
- Step 5** Set the IP address and port for the source.
- ```
set SourceIPAddress 10.81.78.142
set SourcePort 2905
```
- Step 6** Set the `reactivatetimerinterval`.
- Step 7** Set the subsystem number for the local.
- ```
set LocalSubSystemNumber 149
```
- Step 8** Set `routingindicator`.

Set routingindicator rte_gt**Step 9** Set mlcnumber.**Set mlcnumber****Step 10** Set routingparameters.**cd routingparameters/****set OriginPointCode 2****set DestinationPointCode 4****set RemoteSubSystemNumber 6****set OPCMask 16383****set DPCMask 16383****set RoutingContext 11****Step 11** Set the source and destination gt parameters.**Step 12** Set the numbering plan, encoding scheme, format, and digits for source.**Step 13** Set the numbering plan, encoding scheme, format, and digits for destination.

The following shows an example configuration of SIGTRAN-M3UA remote server support:

```
[ //localhost/Radius/RemoteServers/m3ua ]
  Name = m3ua
  Description =
  Protocol = sigtran-m3ua)

  HostName = 10.81.78.138
  SourceIPAddress = 10.81.78.139
  SourcePort = 2905
  LocalSubSystemNumber = 149
  DestinationPort = 2905
  IMSITranslationScript~ =
  GlobalTitleTranslationScript~ = setGT
  Timeout = 15
  ReactivateTimerInterval = 2000
  LimitOutstandingRequests = FALSE
  MaxOutstandingRequests = 0
  MaxRetries = 3
  MAPVersion = 2
  NetworkVariant = ITU
  SubServiceField = NAT
  TCAPVariant = ITU96
  NetworkAppearance = 1
  NetworkIndicator = NAT
  MLCNumber = 123456789012345
  TrafficMode = LOADSHARE
  LoadShareMode = SLS
  RoutingIndicator = RTE_GT
  RoutingParameters/
    OriginPointCode = 2
    DestinationPointCode = 4
```



```

RemoteSubSystemNumber = 6
OPCMask = 16383
DPCMask = 16383
ServiceIndicatorOctet = 0
RoutingContext = 11
SourceGTAddress/
SourceGTDigits = 919845071842
SourceGTFormat = GTFRMT_4
SourceNatureofAddress = INTNUM
SourceTranslationType = 0
SourceNumberingPlan = ISDN
SourceEncodingScheme = BCDEVEN
DestinationGTAddress/
DestGTDigits = 919845071842
DestGTFormat = GTFRMT_4
DestNatureofAddress = INTNUM
DestTranslationType = 0
DestNumberingPlan = ISDN
DestEncodingScheme = BCDEVEN

```

Table 22-1 describes SIGTRAN-M3UA remote server properties.

Table 22-1 *SIGTRAN-M3UA Stack Properties*

Property	Description
Name	Required; inherited from the upper directory.
Description	An optional description of the service.
Protocol	Represents the type of remote server. The value should be SIGTRAN-M3UA.
HostName	IP address of the remote server.
SourceIPAddress	The local IP address in which Cisco Prime AR is installed.
SourcePort	The port number in which Cisco Prime AR is installed for M3UA transactions.
LocalSubSystemNumber	The local sub system number is set as 149 by default.
DestinationPort	The destination port number to which Cisco Prime AR connects.
IMSITranslationScript	The scripting point is used to modify the IMSI based on the requirement before sending the request to STP/HLR.
Timeout	Specifies the time (in seconds) to wait before an authentication request times out; defaults to 120.
ReactivateTimerInterval	Specifies the time interval (in milliseconds) to activate an inactive server; defaults to 300000 ms (which is 5 minutes).
LimitOutstandingRequests	<p>Required; the default is FALSE. Cisco Prime AR uses this property in conjunction with the MaxOutstandingRequests property to tune the RADIUS server's use of the HLR.</p> <p>When you set this property to TRUE, the number of outstanding requests for this RemoteServer is limited to the value you specified in MaxOutstandingRequests. When the number of requests exceeds this number, Cisco Prime AR queues the remaining requests, and sends them as soon as the number of outstanding requests drops to this number.</p>

Table 22-1 SIGTRAN-M3UA Stack Properties (continued) (continued)



Property	Description
MaxOutstandingRe- quests	Required when you have set the LimitOutstandingRequests to TRUE. The number you specify, which must be greater than zero, determines the maximum number of outstanding requests allowed for this remote server.
TrafficMode	The mode of the traffic for the HLR. The possible values are LOADSHARE or ACTSTANDBY.
LoadShareMode	Required. The TrafficMode is set as LOADSHARE, which is a type of load sharing scheme. When there is more than one associations with HLR, then the load sharing is set as Signaling Link Selection (SLS). SLS is done based on a simple round-robin basis.
MAPVersion	The version of the MAP. The possible values are 2 or 3. Specify the MAP version that the HLR supports, i.e, 2 or 3 during the configuration.
NetworkVariant	Required. Represents the network variant switch.  Note Cisco Prime AR supports only ITU value in 6.0 version.
SubServiceField	Specifies the type of network to which this SAP belongs. The possible options are INT and NAT which represents international network and national network respectively.
TCAPVariant	Required; represents the name of the tcap network variant switch. The possible options are ITU88, ITU92, or ITU96.
NetworkAppearance	Required. Represents the network appearance code which ranges from 0-2147483647.
NetworkIndicator	The network indicator used in SCCP address. The possible options are NAT and INT which represents international network and national network respectively.
MLCNumber	Required, if you select FetchAuthorizationInfo as True in EAP-AKA or EAP-SIM services. Also, required for M3UA service for fetching the MSISDN from the HLR. The MLC number is configured in E.164 format.  Note MLC is a max-15 digit number.
RoutingIndicator	Required; represents the routing indicator. The possible values are Route on Gloabl Title(RTE_GT) or Route on Sub System Number(RTE_SSN). You can use either RTE_GT or RTE_SSN value to route the packets for HLR.
RoutingParameters	
OriginPointCode	Required; represents the originating point of a message in a signalling network. The value ranges from 0-16777215.
DestinationPointCode	Required; represents the destination address of a signalling point in a SS7 network.
RemoteSubSystemNum- ber	Required; represents the sub system number of the remote server. The RemoteSubSyatemNumber is set as 6 by default.

Table 22-1 SIGTRAN-M3UA Stack Properties (continued) (continued)

Property	Description
OPCMask	Represents the wild card mask for the origin point code. The value ranges from 0-16777215.
DPCMask	Represents the wild card mask for the destination point code. The value ranges from 0-16777215.
ServiceIndicatorOctet	Represents the service identifier octet. The value ranges from 0-255.
RoutingContext	Required; represents the routing context which ranges from 0-16777215.
SourceGTAddress	
SourceGTDigits	Required; an unique number to identify the source.
SourceGTFormat	Required; represents the format of the global translation (GT) rule. The possible values are GTFRMT_0, GTFRMT_1, GTFRMT_2, GTFRMT_3, GTFRMT_4, or GTFRMT_5.
SourceNatureofAddress	Required; represents the type of the source address. The possible values are ADDR_NOTPRSNT (Address not present), SUBNUM (Subscriber number), NATSIGNUM (National significant number), or INTNUM (International number.)
SourceTranslationType	Required; represents the type of translation. The possible values ranges from 0-255.
SourceNumberingPlan	Required; represents the numbering plan of the network that the subscriber uses. For example, land mobile numbering plan, ISDN mobile numbering plan, private or network specific numbering plan.
SourceEncodingScheme	Required; represents the BCD encoding scheme. The possible values are UNKN (Unknown), BCDODD (BCD Odd), BCDEVEN (BCD Even), or NWSPEC (National specific.)
DestinationGTAddress	
The following fields are displayed only when you set RTE_GT as RoutingIndicator.	
DestGTDigits	Required; an unique number to identify the destination.
DestGTFormat	Required; represents the format of the global translation (GT) rule. The possible values are GTFRMT_0, GTFRMT_1, GTFRMT_2, GTFRMT_3, GTFRMT_4, or GTFRMT_5.
DestNatureofAddress	Required; represents the type of the destination address. The possible values are ADDR_NOTPRSNT (Address not present), SUBNUM (Subscriber number), NATSIGNUM (National significant number), or INTNUM (International number.)
DestTranslationType	Required; represents the type of translation. The possible values ranges from 0-255.
DestNumberingPlan	Required; represents the numbering plan of the network that the subscriber uses. For example, Land mobile numbering plan, ISDN mobile numbering plan, private or network specific numbering plan.
DestEncodingScheme	Required; represents the BCD encoding scheme. The possible values are UNKN (Unknown), BCDODD (BCD Odd), BCDEVEN (BCD Even), or NWSPEC (National specific.)

Configuring M3UA Service

Cisco Prime AR supports the M3UA service, which is used to fetch MSISDN from IMSI through RADIUS Packets, see [Chapter 4, “M3UA,”](#) for more information.

To configure the M3UA service with SIGTRAN-M3UA remote server:

Step 1 Launch `aregcmd`.

Step 2 Create an M3UA service.

```
cd /Radius/Services
```

```
add FetchMSISDN
```

Step 3 Set the type as M3UA.

```
set type M3UA
```

Step 4 Add M3UA remote server in the `remoteServers`.

```
cd remoteServers
```

```
Set 1 m3ua
```



CHAPTER 23

Using SNMP

This chapter provides the following information about Cisco Prime Access Registrar (Cisco Prime AR) support for SNMP:

- [Overview](#)
- [Supported MIBs](#)
- [SNMP Traps](#)

Overview

Cisco Prime AR provides SNMP MIB and trap support for users of network management systems. The supported MIBs enable the network management station to collect state and statistic information from an Cisco Prime AR server. The traps enable Cisco Prime AR to notify interested network management stations of failure or impending failure conditions.

Cisco Prime AR supports the MIBs defined in the following RFCs:

- RADIUS Authentication Client MIB for IPv6, RFC 4668
- RADIUS Authentication Server MIB for IPv6, RFC 4669
- RADIUS Accounting Client MIB for IPv6, RFC 4670
- RADIUS Accounting Server MIB for IPv6, RFC 4671
- CISCO Diameter Base Protocol MIB

Cisco Prime AR MIB support enables a standard SNMP management station to check the current state of the server as well as the statistics on each client or each proxied remote server.

Cisco Prime AR Trap support enables a standard SNMP management station to receive trap messages from an Cisco Prime AR server. These messages contain information indicating that either the server was brought up or down, or that the proxied remote server is down or has come back online.

Supported MIBs

The MIBs supported by Cisco Prime AR enable a standard SNMP management station to check the current state of the server and statistics for each client or proxied remote server.

This section contains the following topics:

- [RADIUS-AUTH-CLIENT-MIB](#)
- [RADIUS-AUTH-SERVER-MIB](#)
- [RADIUS-ACC-CLIENT-MIB](#)
- [RADIUS-ACC-SERVER-MIB](#)
- [CISCO-DIAMETER-BASE-PROTOCOL-MIB](#)
- [Diameter SNMP and Statistics Support](#)
- [TACACS+ SNMP and Statistics Support](#)

RADIUS-AUTH-CLIENT-MIB

The RADIUS-AUTH-CLIENT-MIB describes the client side of the RADIUS authentication protocol. The information contained in this MIB is useful when an Cisco Prime AR server is used as a proxy server.

RADIUS-AUTH-SERVER-MIB

The RADIUS-AUTH-SERVER-MIB describes the server side of the RADIUS authentication protocol. The information contained in this MIB describes managed objects used for managing a RADIUS authentication server.

RADIUS-ACC-CLIENT-MIB

The RADIUS-ACC-CLIENT-MIB describes the client side of the RADIUS accounting protocol. The information contained in this MIB is useful when an Cisco Prime AR server is used for accounting.

RADIUS-ACC-SERVER-MIB

The RADIUS-ACC-CLIENT-MIB describes the server side of the RADIUS accounting protocol. The information contained in this MIB is useful when an Cisco Prime AR server is used for accounting.

CISCO-DIAMETER-BASE-PROTOCOL-MIB

Cisco Prime AR uses the CISCO-DIAMETER-BASE-PROTOCOL-MIB as an interface to query the Diameter statistics, though configuring the Diameter through SNMP is not possible. Cisco Prime AR supports LocalStatistics and PeerStatistics only. The LocalStats provides statistical information about the local diameter server and the PeerStats provides statistical information about the peers and the messages to/from the peers.

Diameter SNMP and Statistics Support

Cisco Prime AR also supports Diameter SNMP MIB (CISCO-DIAMETER-BASE-PROTOCOL-MIB) to describe the Diameter Base Protocol statistics.

Cisco Prime AR supports statistic of Diameter messages to include the additional counters. This is supported through the CLI/GUI and SNMP. The diameter statistics includes peer statistics and global summary statistics details.

TACACS+ SNMP and Statistics Support

Cisco Prime AR supports the CISCO-AAA-SERVER-MIB to describe the statistics of TACACS+ protocol. TACACS+ protocol is used to authenticate an user via various services such as login services see [TACACS+ Support for AA](#) for more information. This is supported through the CLI/GUI and SNMP.

SNMP Traps

The traps supported by Cisco Prime AR enable a standard SNMP management station to receive trap messages from an Cisco Prime AR server. These messages contain information indicating whether a server was brought up or down, or that the proxied remote server is down or has come back online.

A trap is a network message of a specific format issued by an SNMP entity on behalf of a network management agent application. A trap is used to provide the management station with an asynchronous notification of an event.

When a trap is generated, a single copy of the trap is transmitted as a trap PDU to each destination contained within a list of trap recipients.

The list of trap recipients is shared by all events and is determined at server initialization time along with other trap configuration information. The list of trap recipients dictates where Cisco Prime AR traps are directed.

The configuration of any other SNMP agent on the host is ignored. By default, all traps are enabled but no trap recipients are defined. By default, no trap is sent until trap recipients are defined.

Traps are configured using the command line interface (CLI). After configuring traps, the configuration information is re initialized when a server reload or restart occurs.

When you configure traps, you must provide the following information:

- List of trap recipients (community string for each)
- Suppressing traps for any type of message
- Frequency of traps for any type of message

This section contains the following topics:

- [Supported Traps](#)
- [Configuring Traps](#)
- [Community String](#)

Supported Traps

The traps supported by Cisco Prime AR enable the Cisco Prime AR server to notify interested management stations of events, failure, or impending failure conditions. Traps are a network message of a specific format issued by an SNMP entity on behalf of a network management agent application. Traps are used to provide the management station with an asynchronous notification of an event.

This section contains the following topics:

- [carServerStart](#)
- [carServerStop](#)
- [carInputQueueFull](#)
- [carInputQueueNotVeryFull](#)
- [carOtherAuthServerNotResponding](#)
- [carOtherAuthServerResponding](#)
- [carOtherAccServerNotResponding](#)
- [carOtherAccServerResponding](#)
- [carAccountingLoggingFailure](#)
- [carLicenseUsage](#)
- [carDiameterPeerDown](#)
- [carDiameterPeerUp](#)

carServerStart

carServerStart signifies that the server has started on the host from which this notification was sent. This trap has one object, *carNotifStartType*, which indicates the start type. A *firstStart* indicates this is the server process' first start. *reload* indicates this server process has an internal reload. This typically occurs after rereading some configuration changes, but *reload* indicates this server process did not quit during the reload process.

carServerStop

carServerStop signifies that the server has stopped normally on the host from which this notification was sent.

carInputQueueFull

carInputQueueFull indicates that the percentage of use of the packet input queue has reached its high threshold. This trap has two objects:

- *carNotifInputQueueHighThreshold*—indicates the high limit percentage of input queue usage
- *carNotifInputQueueLowThreshold*—indicates the low limit percentage of input queue usage

By default, *carNotifInputQueueHighThreshold* is set to 90% and *carNotifInputQueueLowThreshold* is set to 60%.



Note

The values for these objects cannot be changed at this time. You will be able to modify them in a future release of Cisco Prime AR.

After this notification has been sent, another notification of this type will not be sent again until the percentage usage of the input queue goes below the low threshold.

If the percentage usage reaches 100%, successive requests might be dropped, and the server might stop responding to client requests until the queue drops down again.

carInputQueueNotVeryFull

carInputQueueNotVeryFull indicates that the percentage usage of the packet input queue has dropped below the low threshold defined in *carNotifInputQueueLowThreshold*. This trap has two objects:

- *carNotifInputQueueHighThreshold*—indicates the high limit percentage of input queue usage
- *carNotifInputQueueLowThreshold*—indicates the low limit percentage of input queue usage

After this type of notification has been sent, it will not be sent again until the percentage usage goes back up above the high threshold defined in *carNotifInputQueueHighThreshold*.

carOtherAuthServerNotResponding

carOtherAuthServerNotResponding indicates that an authentication server is not responding to a request sent from this server. This trap has three objects:

- *radiusAuthServerAddress*—indicates the identity of the concerned server
- *radiusAuthClientServerPortNumber*—indicates the port number of the concerned server
- *carAuthServerType*—indicates the type of the concerned server

The index of these three objects identifies the entry in *radiusAuthServerTable* and *carAccServerExtTable* which maintains the characteristics of the concerned server.



Note

One should not rely solely on **carOtherAuthServerNotResponding** for server state. Several conditions, including a restart of the Cisco Prime AR server, could result in either multiple *carOtherAuthServerNotResponding* notifications being sent or in a *carOtherAuthServerResponding* notification *not* being sent. NMS can query the *carAuthServerRunningState* in *carAuthServerExtTable* for the current running state of this server.

carOtherAuthServerResponding

carOtherAuthServerResponding signifies that an authentication server which had formerly been in a *down* state is now responding to requests from the Cisco Prime AR server. This trap has three objects:

- *radiusAuthServerAddress*—indicates the identity of the concerned server
- *radiusAuthClientServerPortNumber*—indicates the port number of the concerned server
- *carAuthServerType*—indicates the type of the concerned server

The index of these three objects identifies the entry in *radiusAuthServerTable* and *carAccServerExtTable* which maintains the characteristics of the concerned server.

One should not rely on receiving this notification as an indication that all is well with the network. Several conditions, including a restart of the Cisco Prime AR server, could result in either multiple *carOtherAuthServerNotResponding* notifications being sent or in a *carOtherAuthServerResponding* notification *not* being sent. The NMS can query the *carAuthServerRunningState* in *carAuthServerExtTable* for the current running state of this server.

carOtherAccServerNotResponding

carOtherAuthServerNotResponding signifies that an accounting server is not responding to the requests sent from this server. This trap has three objects:

- *radiusAccServerAddress*—indicates the identity of the concerned server

- *radiusAccClientServerPortNumber*—indicates the port number of the concerned server
- *carAccServerType*—indicates the type of the concerned server

The index of these three objects identifies the entry in *radiusAuthServerTable* and *arAccServerExtTable* which maintains the characteristics of the concerned server.

One should not solely rely on this for server state. Several conditions, including the restart of the Cisco Prime AR server, could result in either multiple *carOtherAccServerNotResponding* notifications being sent or in a *carOtherAccServerResponding* notification *not* being sent. The NMS can query the *carAccServerRunningState* in *carAccServerExtTable* for current running state of this server.

carOtherAccServerResponding

carOtherAccServerResponding signifies that an accounting server that had previously sent a *not responding* message is now responding to requests from the Cisco Prime AR server. This trap has three objects:

- *radiusAccServerAddress*—indicates the identity of the concerned server
- *radiusAccClientServerPortNumber*—indicates the port number of the concerned server
- *carAccServerType*—indicates the type of the concerned server

The index of these three objects identifies the entry in *radiusAuthServerTable* and *arAccServerExtTable* which maintains the characteristics of the concerned server.

One should not rely on the reception of this notification as an indication that all is well with the network. Several conditions, including the restart of the Cisco Prime AR server, could result in either multiple *carOtherAccServerNotResponding* notifications being sent or in a **carOtherAccServerResponding** notification *not* being sent. The NMS can query the *carAccServerRunningState* in *carAccServerExtTable* for the current running state of this server.

carAccountingLoggingFailure

carAccountingLoggingFailure signifies that this Cisco Prime AR server cannot record accounting packets locally. This trap has two objects:

- *carNotifAcctLogErrorReason*—indicates the reason packets cannot be recorded locally
- *carNotifAcctLogErrorInterval*—indicates how long to wait until another notification of this type might be sent. A value of 0 (zero) indicates no time interval checking, meaning that no new notification can be sent until the error condition is corrected.

carLicenseUsage

carLicenseUsage signifies the percentage of transaction per second(TPS) or session License Usage.

TPS

The TPS trap is generated when the Cisco Prime AR server reaches license usage slabs namely 80%, 90%, 100%, and 110%. These traps are generated only once for every slab during the increasing steady state. Increasing steady state is a state when Cisco Prime ARs' incoming request rate shows 80% of the license usage over a period of 20 minutes. These traps will be regenerated only if a increasing steady state is observed after a decreasing steady state.

Concurrent Session

The concurrent session trap is generated when the Cisco Prime AR server reaches 80%. The incoming traffic slabs defined for trap generation are 80%, 90%, 100%, and 110% of the licensed Concurrent Sessions. These traps are generated once for every slab during the increasing steady state.

carDiameterPeerDown

carDiameterPeerDown signifies that a Diameter peer is down. The identity of the peer is given by `cdpPeerIpAddress`.

carDiameterPeerUp

carDiameterPeerUp signifies that a Diameter peer is up. The identity of the peer is given by `cdpPeerIpAddress`.

Configuring Traps

The Cisco Prime AR SNMP implementation uses various configuration files to configure its applications.

This section contains the following topics:

- [Directories Searched](#)
- [Configuration File Types](#)
- [Switching Configuration Files in Mid-File](#)
- [Configuring Trap Recipient](#)

Directories Searched

Configuration files can be found and read from numerous places. By default, SNMP applications look for configuration files in the following three directories (in the order listed):

1. `/usr/local/share/snmp/snmp.conf`
2. `/usr/local/share/snmp/snmpd.conf`
3. `/usr/local/share/snmp/snmp.local.conf`

This directory contains common configuration for the agent and the application. See man page **snmp.conf(5)** for details.

This directory configures the agent. See man page **snmp.conf(5)** for details.

In each of these directories, an SNMP application looks for files with the extension `.conf`. The application also looks for configuration files in default locations where a configuration file can exist for any given configuration file type.

These files are optional and are only used to configure the extensible portions of the agent, the values of the community strings, and the optional trap destinations. By default, the first community string (“public” by default) is allowed read-only access and the second (“private” by default) is allowed write access, as well. The third to fifth community strings are also read-only.

Additionally, the above default search path can be over-ridden by setting the environmental variable `SNMPCONFPATH` to a colon-separated list of directories to search.

Finally, applications that store persistent data will also look for configuration files in the `/var/snmp` directory.

Configuration File Types

Each application can use multiple configuration files, which will configure various different aspects of the application. For instance, the SNMP agent (**snmpd**) knows how to understand configuration directives in both the **snmpd.conf** and the **snmp.conf** files. In fact, most applications understand how to read the contents of the **snmp.conf** files. Note, however, that configuration directives understood in one file might not be understood in another file. For further information, read the associated manual page with each configuration file type. Also, most of the applications support a '-H' switch on the command line that will list the configuration files it will look for and the directives in each one that it understands.

The **snmp.conf** configuration file is intended to be a application suite-wide configuration file that supports directives that are useful for controlling the fundamental nature of all of the SNMP applications, such as how they all manipulate and parse the textual SNMP MIB files.

Switching Configuration Files in Mid-File

It's possible to switch in mid-file the configuration type that the parser is supposed to be reading. Since that output for the agent by default, but you didn't want to do that for the rest of the applications (for example, **snmpget** and **snmpwalk**, you would need to put a line like the following into the **snmp.conf** file.

```
dumpPacket true
```

But, this would turn it on for all of the applications. So, instead, you can put the same line in the **snmpd.conf** file so that it only applies to the **snmpd** demon. However, you need to tell the parser to expect this line. You do this by putting a special type specification token inside a square bracket (`[]`) set. In other words, inside your **snmpd.conf** file you could put the above **snmp.conf** directive by adding a line like the following:

```
[snmp] dumpPacket true
```

This tells the parser to parse the above line as if it were inside a **snmp.conf** file instead of an **snmpd.conf** file. If you want to parse a bunch of lines rather than just one then you can make the context switch apply to the remainder of the file or until the next context switch directive by putting the special token on a line by itself:

```
# make this file handle snmp.conf tokens:
[snmp]
dumpPacket true
logTimestamp true
# return to our original snmpd.conf tokens:
[snmpd]
rocommunity mypublic
```

Configuring Trap Recipient

The following example shows the default configuration that sets up trap recipients for SNMP versions v1 and v2c.

Note

Most sites use a single NMS, not two as shown below.

```
# -----
trapcommunity trapcom
trapsink zubat trapcom 162
trap2sink ponyta trapcom 162
#####
```

Note

trapsink is used in SNMP version 1; **trap2sink** is used in SNMP version 2.

trapcommunity defines the default community string to be used when sending traps. This command must appear prior to **trapsink** or **trap2sink** which use this community string.

trapsink and **trap2sink** are defined as follows:

```
trapsink  hostname  community  port
trap2sink hostname  community  port
```

Community String

A community string is used to authenticate the trap message sender (SNMP agent) to the trap recipient (SNMP management station). A community string is required in the list of trap receivers.



CHAPTER 24

Enforcement of Licensing Models

This chapter describes the enforcement of transactions per second (TPS) based licensing and session based licensing models introduced in Cisco Prime Access Registrar (Cisco Prime AR).

In TPS based licensing model, the license is based on the number of transactions per second that are handled by the server. In session based licensing model, the license is managed based on the number of sessions that resides in Cisco Prime AR. During Cisco Prime AR startup, you can either load TPS based licensing or session based licensing, but not both at the same time.

This chapter contains the following sections:

- [TPS Licensing Features](#)
- [Concurrent Session License Features](#)



Note

The type of licensing will determine the applicable features and its corresponding enforcement.

TPS Licensing Features

The following are the features of TPS licensing:

- License will enable features but with restriction enforced on the TPS.
- TPS is the number of packets flowing into Cisco Prime AR. This is accounted by Cisco Prime AR irrespective of the feature being used.

This section contains the following topics:

- [Enforcement Rules](#)
- [Notification Logs](#)
- [Notification - SNMP Traps](#)
- [TPS Logging Feature](#)

Enforcement Rules

Any license enforcement is triggered only after Cisco Prime AR has observed increasing steady state in TPS. Increasing steady state is marked by the steady increase in incoming traffic (measured in TPS) beyond 80% of the licensed TPS for any 15 minutes of a 20 minute interval.

The following are the enforcement rules applied on reaching increasing steady state:

- When the incoming traffic (measured in TPS) is greater than 80% of the licensed TPS, SNMP Trap will be generated for the first time on reaching the increased steady state. The warning message on the current license usage is logged for every 5 minutes.
- When the incoming traffic (measured in TPS) is greater than 90% of the licensed TPS, SNMP Trap will be generated for the first time on reaching the increased steady state. Warning message on the current license usage is logged for every 5 minutes.
- When the incoming traffic (measured in TPS) is greater than 100% of the licensed TPS, SNMP Trap will be generated for the first time on reaching the increased steady state. Error message on the current license usage is logged for every 5 minutes.
- When the incoming traffic (measured in TPS) is greater than 110% of the licensed TPS, SNMP Trap will be generated for the first time on reaching the increased steady state.

Note

Steady state denotes continuous increase or decrease in the TPS within a given TPS range. For the purpose of enforcement of licensing in Cisco Prime AR, the range is always 80% and above. The enforcement begins after TPS reaches and is greater than 80% for a steady state of 20 minutes.

Notification Logs

A warning message is logged for every 5 minutes when the TPS count reaches an increased steady state, where, the TPS count is in the range of 80% to 100% of the licensed TPS.

An error message is logged for every 5 minutes when the TPS count reaches an increased steady state, where, the TPS count is in the range of 100% to 110% of the licensed TPS.

Notification - SNMP Traps

The **carLicenseUsage** traps are generated only once in an increasing phase. The incoming traffic slabs are defined as 80%, 90%, 100%, and 110% of the licensed TPS. When the incoming traffic slabs reaches an increasing steady state of 80% or above for the first time, the respective trap is generated for the slab.

If the TPS count drops below 80% of the licensed TPS for a steady state period of 20 minutes, Cisco Prime AR marks it as decreased or normal steady state. Traps will be regenerated again only if Cisco Prime AR observes a decreased steady state followed by an increased steady state of TPS falling under the slab (say 80%).

TPS Logging Feature

The properties in Advanced Object such as TPSSamplingPeriodInSecs, LogTPSActivity, TPSLogFilenamePrefix and TPSLogFileCount enable logging of TPS in the Cisco Prime AR server. TPS log file is located in `/cisco-ar/logs`. It creates one file per day to hold the TPS information for the day. The TPS samples are collected for every TPSSamplingPeriodInSecs. The file is updated only once for every $10 * \text{TPSSamplingPeriodInSecs}$. If there is no inflowing traffic, Cisco Prime AR logs zero TPS once for every $10 * \text{TPSSamplingPeriodInSecs}$. See [Table 4-43 Advanced Object Properties](#) for more information on TPSSamplingPeriodInSecs, LogTPSActivity, TPSLogFilenamePrefix, and TPSLogFileCount properties.

The following is the sample configuration of tps license:

```
/cisco-ar/bin/aregcmd -s
set /Radius/Advanced/LogTPSActivity TRUE
set /Radius/Advanced/TPSLogFilenamePrefix tps
set /Radius/Advanced/TPSLogFileCount 5
set /Radius/Advanced/TPSSamplingPeriodInSecs 10
save
```

The following is the sample output of the log file:

```
bash-3.00# tail -f tps-09-23-2010.csv
09-23-2010, 7:22:03,3512
09-23-2010, 7:22:33,3494
09-23-2010, 7:23:03,3130
09-23-2010, 7:23:33,3525
09-23-2010, 7:24:03,3525
09-23-2010, 7:24:33,3165
09-23-2010, 7:25:03,3523
09-23-2010, 7:25:33,3488
09-23-2010, 7:26:03,3155
09-23-2010, 7:26:33,3486
```

For TPS measurement in Cisco Prime AR server, you can run the TPS calculator script when you want to monitor the TPS during the peak period or run the TPS for 24 hours. The TPS calculator script is separately available for Linux and Solaris platforms.

**Note**

Cisco BU provides the corresponding TPS calculator script based on Linux or Solaris platform.

Concurrent Session License Features

In Concurrent Session based license, the licensing is done based on the number of sessions that resides in Cisco Prime AR.

**Note**

During startup of the Cisco Prime AR, the default session manager must be enabled for RADIUS and the EnableStickySession must be set to TRUE for Diameter. This is applicable only for session based license.

The sticky sessions is enabled during the initialization of Cisco Prime AR for Diameter based license to track the session counts in the diameter service. The server level count is calculated by adding all the sessions maintained across all the session managers and the sticky sessions of all the diameter services in the server. This session count is used by licensing module for license enforcement. The session count is either increased or decreased based on the action performed.

This section contains the following topics:

- [Sessions Enforcement Rules](#)
- [Notification Logs](#)
- [Notification - SNMP Traps](#)
- [Session Logging Feature](#)

Sessions Enforcement Rules

The following are the enforcement rules applied on concurrent session based license:

- When the session count (measured in concurrent session) reaches 80% of the licensed sessions, SNMP Trap will be generated for the first time on reaching the increased steady state. The warning message on the current license usage is logged for every 5 minutes.
- When the session count (measured in concurrent session) reaches 90% of the licensed sessions, SNMP Trap will be generated for the first time on reaching the state. The warning message on the current license usage is logged for every 5 minutes.
- When the session count (measured in concurrent session) attains 100% of the licensed sessions, SNMP Trap will be generated for the first time on reaching the state. The error message on the current license usage is logged for every 5 minutes.
- When the session count (measured in concurrent session) attains 110% of the licensed sessions, SNMP Trap will be generated for the first time on reaching the state.

**Note**

The steady state period is not applicable for Concurrency Session based licensing.

Notification Logs

A warning message is logged for every 5 minutes when the session count reaches 80% and 90% of the licensed Concurrent Session.

An error message is logged when the session count reaches the range of 100% to 110% of the licensed Concurrent Session.

Notification - SNMP Traps

The **carLicenseUsage** trap is generated when the Cisco Prime AR server reaches 80%. The incoming traffic slabs defined for trap generation are 80%, 90%, 100%, and 110% of the licensed Concurrent Sessions. These traps are generated once for every slab during the increasing steady state.

**Note**

Logging Feature is applicable for session based license as like TPS logging feature. The warning messages are displayed corresponding to session logging feature. See [TPS Logging Feature, page 24-3](#) for more information.

Session Logging Feature

The properties in Advanced Object such as `SessionSamplingPeriodInSecs`, `LogSessionActivity`, `SessionLogFilenamePrefix` and `SessionLogFileCount` enable logging of session count in the Cisco Prime AR server. The session log file is located in `/cisco-ar/logs`. It creates one file per day to hold the session information for the day. The session samples are collected for every `SessionSamplingPeriodInSecs`. The file is updated only once for every `10 * SessionSamplingPeriodInSecs`. See [Table 4-43 Advanced Object Properties](#) for more information on `SessionSamplingPeriodInSecs`, `LogSessionActivity`, `SessionLogFilenamePrefix`, and `SessionLogFileCount` properties.

The following is a sample configuration of session license:

```
/cisco-ar/bin/aregcmd -s
set /Radius/Advanced/LogSessionActivity TRUE
set /Radius/Advanced/SessionLogFilenamePrefix sm
set /Radius/Advanced/SessionLogFileCount 5
set /Radius/Advanced/SessionSamplingPeriodInSecs 10
save
```

The following is the sample output of the log file:

```
bash-3.00# tail -f sm-08-09-2012.csv

08-09-2012, 5:18:52,73749
08-09-2012, 5:19:22,100001
08-09-2012, 5:19:52,100001
08-09-2012, 5:20:22,100001
08-09-2012, 5:20:52,100001
08-09-2012, 5:21:22,100001
08-09-2012, 5:21:52,100001
```



CHAPTER 25

Backing Up the Database

This chapter describes the Cisco Prime Access Registrar (Cisco Prime AR) shadow backup facility, which ensures a consistent snapshot of Cisco Prime AR's database for backup purposes.

Because the Cisco Prime AR's database (called MCD) does a variety of memory caching, and might be active at any time, you cannot simply rely on doing system backups to protect the data in the database. At the time you run a system backup, there could be Cisco Prime AR operations in progress that cause the data copied to the system backup tape to be inconsistent and unusable as a replacement database.

To ensure a consistent backup, Cisco Prime AR uses a shadow backup facility. Once a day, at a configurable time, Cisco Prime AR suspends all activity to the database and takes a snapshot of the critical files. This snapshot is guaranteed to be a consistent view of the database, and it is preserved correctly on a system backup tape.

This chapter contains the following sections:

- [Configuration](#)
- [Recovery](#)
- [mcdshadow Command Files](#)

Configuration

The only configuration for this facility is through a single entry in the system Registry at `$INSTALL/conf/car.conf` is the registry path to this item.

This entry is a string that represents the time-of-day at which the shadow backup is scheduled to occur (in 24 hour HH:MM format). The default is 12:45.

When you remove this entry or set it to an illegal value (for example, anything that does not begin with a digit), backups are suppressed.

Command Line Utility

In addition to being available at a scheduled time of day, you can also force a shadow backup by using the `mcdshadow` utility located in the `$INSTALL/bin` directory. There are no command-line arguments.

This might take a few minutes to complete as a full copy of the database is created.

Recovery

When it is necessary to use the shadow backup to recover data, either because the regular working database has been corrupted by a system crash, or because the disk on which it resides has become corrupted.

Recovering the data using shadow backup

To use the shadow backup to recover data:

-
- Step 1** Stop all Cisco Prime AR servers.
- Step 2** Make sure three files (**mcddb.d01**, **mcddb.d02**, and **mcddb.d03**) exist in the **\$INSTALL/data/db.bak** directory.
- Step 3** Copy the files into the **\$INSTALL/data/db** directory. Do not move them because they might be needed again.
- Step 4** Change directory to the **\$INSTALL/data/db** directory.
- ```
cd $INSTALL/data/db
```
- Step 5** Rebuild the key files by entering the command:
- ```
$INSTALL/bin/keybuild mcddb
```
- This might take several minutes.
- Step 6** As a safety check, run **\$INSTALL/bin/dbcheck mcddb** (UNIX) to verify the integrity of the database. Note, you must be user **root** to run **dbcheck**.
- No errors should be detected.
-

mcshadow Command Files

The **mcshadow** command uses the files listed in [Table 25-1](#).

Table 25-1 *mcshadow Files*

File	Description
mcddb.dbd	Template file that describes the low-level data schema for the Raima runtime library.
mcddb.k01 mcddb.k02 mcddb.k03	Key files that contain the data that is redundant with the data files. Cisco Prime AR does not back up these files because they can be completely rebuilt with the keybuild command.
mcddcd.d01 mcddcd.d02 mcddcd.d03	Data files that contain the backup.
mcdConfig.txt	Text file from which Cisco Prime AR configures the initial at-install-time database.

Table 25-1 *mcdshadow Files (continued)*

File	Description
mcdschema.txt	Text file that contains a version number denoting the level of the schema contained in the dbd file. Cisco Prime AR will not attempt to open the database unless the number in this file matches a constant that is hard-coded in the libraries. If the result of the mcdshadow command (which uses copies of the data files) is divorced from its original mcdschema.txt, you will not be able to run Cisco Prime AR.
vista.taf vista.tcf vista.tjf	Working files used by the Raima runtime library to ensure transactional integrity.



CHAPTER 26

Using the REX Accounting Script

This chapter describes how to use the REX Accounting Script (RAS). The RAS writes RADIUS Accounting requests to a local, flat file and is included as an option for Cisco Prime Access Registrar (Cisco Prime AR). It is designed to be attached to a Cisco Prime AR IncomingScript or OutgoingScript point. When used in conjunction with the Cisco Prime AR built-in proxy support, the server will concurrently store a local copy of an Accounting request and proxy another copy to another RADIUS server.



Note

Unless you require log rotation at an exact time or when the accounting log reaches a specific file size, Cisco recommends that you use service grouping to log and proxy accounting packets.

RAS can be attached to more than one Cisco Prime AR extension point. For example, in a dial-up resale scenario, you might configure Cisco Prime AR to proxy Accounting requests to many different Remote Servers (by realm). For some subset of those, you might want to keep a local copy of the Accounting requests. In this case, RAS could be installed as the IncomingScript on just the Services for which a local copy is desired.



Note

Also included is the **DropAcctOnOff** Script. This script causes Cisco Prime AR to drop all Accounting-Requests with an **Acct-Status-Type** of **Accounting-On** or **Accounting-Off**.

This chapter contains the following sections:

- [Building and Installing the REX Accounting Script](#)
- [Configuring the Rex Accounting Script](#)
- [Specifying REX Accounting Script Options](#)

Building and Installing the REX Accounting Script

The RAS writes RADIUS Accounting requests to a local, flat file and is included as an option for Cisco Prime Access Registrar (Cisco Prime AR). It is designed to be attached to a Cisco Prime AR IncomingScript or OutgoingScript point.

Building and Installing the REX Accounting Script

To build and install RAS:

-
- Step 1** Change directory to `$INSTALL/examples/rexacctscript`.
- Step 2** Modify the **Makefile** to ensure the `AR_INSTALL_DIR` variable points to the directory where the Cisco Prime AR software was installed, and then choose a compiler (`gcc` or `SUNPro CC`).
- Step 3** From the command line prompt, enter:
- ```
host% make
```
- Step 4** Log in as user `root`.
- Step 5** From the command line prompt, enter:
- ```
host# make install
```
-

Configuring the Rex Accounting Script

RAS can be attached to more than one Cisco Prime AR extension point. For example, in a dial-up resale scenario, you might configure Cisco Prime AR to proxy Accounting requests to many different Remote Servers (by realm).

Configuring the Rex Accounting Script

To configure RAS:

-
- Step 1** Start the Cisco Prime AR `aregcmd` configuration utility and login:
- ```
> $INSTALL/usrbin/aregcmd -C localhost -N admin -P aicuser
Access Registrar Configuration Utility Version 1.3
Copyright (C) 1995-2008 by Cisco Systems, Inc. All rights reserved.
Logging in to localhost
[//localhost]
 LicenseKey = xxxx-xxxx-xxxx-xxxx
 Radius/
 Administrators/
Server 'Radius' is Running, its health is 10 out of 10
-->
```
- Step 2** Using `aregcmd`, create a new Cisco Prime AR Script object:
- ```
--> cd /Radius/Scripts
[ //localhost/Radius/Scripts ]
    Entries 1 to 20 from 39 total entries
    Current filter: <all>
    ACMEOutgoingScript/
    AscendIncomingScript/
<... other output deleted...>
--> add LocalAccounting
Added LocalAccounting
```

- Step 3** Using **aregcmd**, fill in the details of the new Cisco Prime AR Script object. See [Chapter 4, “Cisco Prime Access Registrar Server Objects,”](#) for more details.

--> **cd LocalAccounting**

```
[ //localhost/Radius/Scripts/LocalAccounting ]
    Name = LocalAccounting
    Description =
    Language =
    Filename =
    EntryPoint =
    InitEntryPoint =
    InitEntryPointArgs =
```

--> **set Desc “Log Accounting requests to local file”**

```
Set Description "Log Accounting requests to local file"
```

--> **set lang REX**

```
Set Language REX
```

--> **set filename libRexAcctScript.so**

```
Set Filename libRexAcctScript.so
```

--> **set entry RexAccountingScript**

```
Set EntryPoint RexAccountingScript
```

--> **set initentrypoint InitRexAccountingScript**

```
Set InitEntryPoint InitRexAccountingScript
```

--> **set initentrypointargs “-f Accounting -t 1:15”**

```
Set InitEntryPointArgs "-f Accounting -t 1:15"
```

--> **ls**

```
[ //localhost/Radius/Scripts/LocalAccounting ]
    Name = LocalAccounting
    Description = "Log Accounting requests to local file"
    Language = REX
    Filename = libRexAcctScript.so
    EntryPoint = RexAccountingScript
    InitEntryPoint = InitRexAccountingScript
    InitEntryPointArgs = "-f Accounting -t 1:15"
```

-->

- Step 4** Using **aregcmd**, attach the new Cisco Prime AR Script object to the appropriate Cisco Prime AR Scripting point. See [Chapter 4, “Cisco Prime Access Registrar Server Objects,”](#) for more details.

--> **set /radius/IncomingScript LocalAccounting**

```
Set /Radius/IncomingScript LocalAccounting
```

- Step 5** Using **aregcmd**, save the configuration modifications:

--> **save**

```
Validating //localhost...
```

```
Saving //localhost...
```

- Step 6** Using **aregcmd**, reload the server:

--> reload

```
Reloading Server 'Radius'...
Server 'Radius' is Running, its health is 10 out of 10
```

Specifying REX Accounting Script Options

The REX Accounting Script supports the options shown in [Table 26-1](#).

Table 26-1 REX Accounting Script Supported Options

Option	Description
-f <filename>	Required. Specify the name of the output file.
-t <HH:MM[:SS]>	Specify a time of day to roll the output file. Note, this is time on the 24-hour clock, for example, 00:05 = 12:05am, 13:30 = 1:30pm. This option can not be used with the -i option.
-i <seconds>	Specify the number of seconds between rolling the output file, beginning at start-up. This option can not be used with the -t option.
-s <size>[k ml g]	Specify the maximum size for an output file. When the file reaches this size, it will be rolled. When specifying the <size> option, a <unit> can be included. When a <unit> is not included, the <size> is in bytes. Note, do not use a space character between the <size> and <unit> options. <unit> can be either: k = 1K, m = 1Meg, g = 1Gig.
-g	Use GMT when writing the date/time in the Accounting output file for each record (default is local time).
-G	Use GMT when naming rolled output files (default is local time).
-A	Process all packets, not just Accounting-Requests.
-I	Ignore errors when processing packets, always return successfully.
-a <buffer-count>	Pre-allocate this many Accounting buffers to improve performance.
-T <trace-level>	Set the trace level. This trace info appears in the output file (as its written by the background thread which no longer has a packet to use for logging or tracing.)
-O <script-description>	Call another REX extension before calling the RexAcctScript .
-o <script-description>	Call another REX extension after calling the RexAcctScript .

Example Script Object

This is an example of what a Cisco Prime AR Script object using RAS might look like when viewed in the Cisco Prime AR configuration utility, **aregcmd**:

```
[ //localhost/Radius/Scripts/REX-Accounting-Script ]
  Name = REX-Accounting-Script
  Description =
  Language = REX
  Filename = librexacctscript.so
  EntryPoint = RexAccountingScript
  InitEntryPoint = InitRexAccountingScript
  InitEntryPointArgs = "-f Accounting -t 16:20 -s 100k -o
    libRexAcctScript.so:DropAcctOnOff"
```

This example causes RAS to write to a file called **Accounting.log** (in the **logs** directory of the installation tree). The file rolls every day at 4:20pm (local time), as well as whenever it grows larger than 100k in size. RAS also runs the **DropAcctOnOff** script against every packet, after it has processed the packet.



CHAPTER 27

Logging Syslog Messages

Logging messages via syslog provides centralized error reporting for Cisco Prime Access Registrar (Cisco Prime AR). Local logging and syslog logging can be turned on or off at any time by modifying the control flags in the `$INSTALLPATH/conf/car.conf` file.

Logging syslog messages requires a UNIX host running a *syslog daemon* as a receiver for Cisco Prime AR messages. Cisco Prime AR and the syslog daemon can be running on the same host or different hosts.

This chapter contains the following sections:

- [Syslog Messages](#)
- [Configuring Message Logging \(Solaris\)](#)
- [Configuring Message Logging \(Linux\)](#)
- [Changing Log Directory](#)
- [Configuring Syslog Daemon \(syslogd\)](#)
- [Managing the Syslog File](#)
- [Server Up/Down Status Change Logging](#)

Syslog Messages

Messages sent to the following logs will be forwarded to **syslog** server in a slightly different format. The logs are:

- `aregcmd_log`
- `config_mcd_[1..n]_log`
- `name_radius_[1..n]_log`
- `agent_server_[1..n]_log`

Messages less than 1024 bytes in length display in the following format:

```
MMM DD hh:mm:ss hostname %Cisco Prime AR-[severity]-[mnemonic]: [#n], [System|Server]:  
message_description
```

Where:

MMM DD is the month and date that the message is received by the syslog server.

hh:mm:ss is the arrival time of the message.

hostname is the name of the syslog server.

severity is one of the following levels:

- 0 - emergency
- 1 - alert
- 2 - critical
- 3 - error
- 4 - warning
- 5 - notification
- 6 - informational
- 7 - debugging

mnemonic can be *aregcmd*, *name_radius*, *agent_server* and *config_mcd* for the identification of Cisco Prime AR-relative subsystems.

#n is the id for the components: *name_radius*, *agent_server*, and *config_mcd*

message_description provides detailed information of the message.

Messages greater than 1024 bytes in length display in multiple lines. At the end of each 1024 bytes line, three dots indicate a continuation of the message as follows:

```
MMM DD hh:mm:ss hostname %Cisco Prime AR-[severity]-[mnemonic]: [#n], [System|Server]:
message_description: Configuration: text and more message text and more message text
and more message text and more message text and more message text and more message
text and more message text and more message text and more message text and more
message text and more message text and more message text and more message text and
more message text and more message text and more message text and more message text
and more message text and more message text and more message text and more message
text and more message text and more message text and more message text ...
```

The continuation of a message begins with three dots as follows:

```
MMM DD hh:mm:ss hostname %Cisco Prime AR-[severity]-[mnemonic]: [#n], [System|Server]:
message_description: Configuration: ... text and more message text and more message
text and more message text and more message text and more message text and more
message text and more message text and more message text and more message text and
more message text and more message text and more message text
```

Example 1

```
May 19 14:28:44 dwlau-ultra2.cisco.com
%Cisco Prime AR-3-name_radius: #1, System: Remote LDAP Server.Unable to bind.
```

Example 2

```
May 19 14:28:45 dwlau-ultra2.cisco.com
%Cisco Prime AR-6-name_radius: #1, Server: Stopping server
```

Configuring Message Logging (Solaris)

Message logging is on by default, and all logs are stored in the `$INSTALL/logs` directory. To turn logging off, or to change the location where logs are stored, you must modify the `$INSTALLPATH/conf/car.conf` file.

In `$INSTALLPATH/conf/car.conf` file, the following lines control logging.

```
LOCAL_LOGGING [ON|OFF]
LOGDIR full_path
DATADIR full_path
SYSLOG_LOGGING [ON|OFF]
SERVER_IP_ADDRESS [ip_address]
FACILITY_LOCAL_NUMBER [0..7]
```

Where:

LOCAL_LOGGING enables (ON) or disables (OFF) the local logging function. (Local logging is on by default.)

LOGDIR specifies a full pathname to a different local log directory.

DATADIR specifies a full pathname to a different data directory.

SYSLOG_LOGGING enables (ON) or disables (OFF) the syslog logging function. (syslog logging is on by default.)

SERVER_IP_ADDRESS specifies the IP address of the host to which Cisco Prime AR will send syslog messages.

FACILITY_LOCAL_NUMBER specifies the facility being used by the syslogd.

The following is an example:

```
LOCAL_LOGGING OFF
SYSLOG_LOGGING ON
SERVER_IP_ADDRESS 209.165.200.224
FACILITY_LOCAL_NUMBER 7
```

**Note**

You must first stop the Cisco Prime AR server prior to changing the `car.conf` file, then restart the server. If you change the directory location where logs or database data are stored, you should also copy all log files or data files to that same directory before restarting the Cisco Prime AR server.

Configuring Message Logging (Linux)

To enable **syslog** logging in Linux, you must modify the **syslog** file in the **/etc/sysconfig** directory. The following is the default syslog file.

```
# Options to syslogd
# -m 0 disables 'MARK' messages.
# -r enables logging from remote machines
# -x disables DNS lookups on messages recieved with -r
# See syslogd(8) for more details
SYSLOGD_OPTIONS="-m 0"
# Options to klogd
# -2 prints all kernel oops messages twice; once for klogd to decode, and
#   once for processing with 'ksymoops'
# -x disables all klogd processing of oops messages entirely
# See klogd(8) for more details
KLOGD_OPTIONS="-x"
```

To enable logging of **syslog** messages, you must enable the **syslog** daemon to listen on port 514 by adding the **-r** flag to the **SYSLOGD_OPTIONS** line as follows:

```
SYSLOGD_OPTIONS="-m 0 -r"
```

Changing Log Directory

You can change the directory where local log messages are stored by adding the following line in the **\$INSTALLPATH/conf/car.conf** file.

```
LOGDIR full_path
```

Where *full_path* is a full path to the directory where you want to store the log messages. For example, to store all system logs in **/var/log/AICar1**, add the following line in the **\$INSTALLPATH/conf/car.conf** file:

```
LOGDIR /var/log/AICar1
```

You must first stop the Cisco Prime AR server prior to changing the **car.conf** file. After changing the **car.conf** file, copy all existing log files to the new directory, then restart the server.



Note

Specifying a path for local logging does not affect the storage location of syslog messages.

Configuring Syslog Daemon (syslogd)

You must specify the facility from which *syslogd* will receive messages and the file into which the messages will be deposited.

In the syslog server's */etc/syslog.conf* file, the following line might be needed.

```
localn.info <tab> <tab> <tab> /var/log/filename.log
```



Note Use at least one <tab> as a field separator.

Where:

localn—is the facility being used for syslogd; *n* must be a value from 0-7 and match the FACILITY_LOCAL_NUMBER used in Cisco Prime AR's *car.conf* file.

/var/log/—is the path to the file that stores **syslogd** messages.

filename.log—is the file that stores **syslogd** messages. You can give this file a name of your choice.

Creating a Syslog Log File

To create a syslog log file:

-
- Step 1** Log in as user *root*.
- Step 2** Enter the following command, where *filename.log* is a name you choose.
- ```
touch filename.log
```
- Step 3** Change permissions on the syslog log file by entering the following:
- ```
chmod 664 filename.log
```
-

Restarting a syslog daemon

To restart the **syslog** daemon:

log in as user *root* and enter the following commands:

```
/etc/init.d/syslog stop
```

```
/etc/init.d/syslog start
```

Managing the Syslog File

Left unmanaged, the **syslog** file will grow in size over time and eventually fill all available disk space in its partition. Cisco Prime AR writes log files and session data (to persist user sessions) in the same disk partition where Cisco Prime AR is installed.

In normal operation, log files consume a large amount of disk space. If log files are not managed regularly, Cisco Prime AR might not have sufficient disk space to write session data. To avoid this, you should move the Cisco Prime AR log files directory to a different disk partition than the one where Cisco Prime AR writes session data, as described in [Changing Log Directory](#).

Using a cron Program to Manage the Syslog Files

Cisco recommends that you use the **crontab** program to manage the **syslog** files.

The following example **crontab** file performs a weekly archival of the existing **syslog** file (named **ar_syslog.log** in this example). This scheme keeps the previous two week's worth of **syslog** files.

```
#
# At 02:01am on Sundays:
# Move a weeks worth of 'ar_syslog.log' log messages to 'ar_syslog.log.1'.
# If there was a 'ar_syslog.log.1' move it to 'ar_syslog.log.2'.
# If there was a 'ar_syslog.log.2' then it is lost.
01 02 * * 0 cd /var/log;
if [ -f ar_syslog.log ];
then if [ -f ar_syslog.log.1 ];
then /bin/mv ar_syslog.log.1 ar_syslog.log.2;
fi;
/usr/bin/cp ar_syslog.log ar_syslog.log.1;
>ar_syslog.log;
fi
```



Note Consider using move (**mv**) or copy (**cp**) commands to store the previous week's syslog files in a different disk partition to reserve space for the current syslog file.

Using a cron Program to Manage the Syslog Files

To add this **crontab** segment to the existing **crontab** facility in **/usr/spool/cron/crontabs** directory, complete the following steps at the syslog server console:

-
- Step 1** Log in as user *root*.
- Step 2** Enter the following command:
- ```
crontab -e
```
- 

## Server Up/Down Status Change Logging

Cisco Prime AR supports RADIUS server up/down detection and logging. The information messages are saved in the **\$INSTALL/logs/name\_radius\_1\_log** file where **\$INSTALL** is the Cisco Prime AR installation directory. Each message consists of a header and a message description.

### Header Formats

The format of a header entry is:

```
mm/dd/yyyy HH:MM:SS name/radius/n Error Server 0
```

## Example Log Messages

Following are the descriptions and types of messages that can be found within the `<AR_install_dir>/logs/name_radius_1_log` file:

1. Cisco Prime AR detects a Remote Server when it responds for the first time or after it is reentered into Cisco Prime AR's server pool for retry. The format of the message is:

Remote Server `<hostname>` (`<ipaddress>`:`<port>`) is UP!

The following is an example header and message:

```
10/12/2012 17:56:32 name/radius/1 Error Server 0
Remote Server dave-ultra (171.69.127.99:1645) is UP!
```

Cisco Prime AR detects the Remote Server is not responding to its request. The format of the message is:

Remote Server `<hostname>` (`<ipaddress>`:`<port>`) is DOWN!

The following is an example header and message:

```
10/12/2012 17:57:12 name/radius/1 Error Server 0 Remote
server dave-ultra (171.69.127.99:1645) is DOWN!
```

2. Cisco Prime AR receives no response from the Remote Server after the server is reentered into Cisco Prime AR's server pool for retry. The format of the message is:

Remote Server `<hostname>` (`<ipaddress>`:`<port>`) remains DOWN!

The following is an example header and message:

```
10/12/2012 17:56:32 name/radius/1 Error Server 0 Remote
server dave-ultra (171.69.127.99:1645) remains DOWN!
```

3. The Remote Server is responding to the first retry but not the initial request. The format of the message is:

Remote Server `<hostname>` (`<ipaddress>`:`<port>`) is UP but slow!

The following is an example header and message:

```
10/12/2012 17:56:32 name/radius/1 Error Server 0 Remote
server dave-ultra (171.69.127.99:1645) is UP but slow!
```

4. The Remote Server is responding to the second retry request but not the initial request or the first retry request. The format of the message is:

Remote Server `<hostname>` (`<ipaddress>`:`<port>`) is UP but very slow!

The following is an example header and message:

```
10/12/2012 17:56:32 name/radius/1 Error Server 0 Remote
server dave-ultra (171.69.127.99:1645) is UP but very slow!
```

5. The Remote Server has been marked inactive and is being put back into Cisco Prime AR's server pool for later use. The format of the message is:

Remote Server `<hostname>` (`<ipaddress>`:`<port>`) is being reactivated for later use.

The following is an example header and message:

```
10/12/2012 17:56:32 name/radius/1 Error Server 0 Remote
server dave-ultra (209.165.200.224:1645) is being reactivated for later use.
```





# CHAPTER 28

## Troubleshooting Cisco Prime Access Registrar

This chapter provides information about techniques used when troubleshooting Cisco Prime Access Registrar (Cisco Prime AR) and highlights common problems.

This chapter contains the following sections:

- [Gathering Basic Information](#)
- [Troubleshooting Quick Checks](#)
- [aregcmd and Cisco Prime Access Registrar Configuration](#)
- [RADIUS Request Processing](#)
- [Other Troubleshooting Techniques and Resources](#)
- [Checking AR Server Health Status](#)

### Gathering Basic Information

Table 28-1 lists UNIX commands that provide basic and essential information to help you understand the Cisco Prime AR installation environment.

**Table 28-1** UNIX Commands to Gather Information

| UNIX Command                   | Information Returned                                                                                 |
|--------------------------------|------------------------------------------------------------------------------------------------------|
| <code>/usr/bin/uname -r</code> | Solaris release level                                                                                |
| <code>/usr/bin/uname -i</code> | Machine hardware name                                                                                |
| <code>/usr/bin/uname -v</code> | Solaris version                                                                                      |
| <code>/usr/bin/uname -a</code> | All system information including hostname, operating system type and release, machine model and type |
| <code>/usr/sbin/prtconf</code> | System configuration information including memory capacity, machine type, and peripheral equipment   |
| <code>/usr/sbin/df -k</code>   | File system disk space usage including partitions, capacity, and space used                          |
| <code>/usr/bin/ps -ef</code>   | Currently running processes                                                                          |

**Table 28-1** UNIX Commands to Gather Information (continued)

| UNIX Command                            | Information Returned                                                                        |
|-----------------------------------------|---------------------------------------------------------------------------------------------|
| <code>/usr/sbin/psinfo -v</code>        | Information about processors                                                                |
| <code>/usr/bin/pkginfo -l CSC0ar</code> | Software package information about Cisco Prime AR version number and installation directory |

**Note**

More information about these commands and their options is available using the **man** command in a terminal window on the Sun workstation.

## Troubleshooting Quick Checks

Many of the most common problems can be diagnosed by doing the following:

- Check disk space
- Check for resource conflicts
- Check the Cisco Prime AR log files

## Disk Space

Running out of disk space can cause a number of problems including:

- Failure to process RADIUS requests
- Parts of the Cisco Prime AR configuration *disappearing* in **aregcmd**
- Failure to log into **aregcmd**

Check that the Cisco Prime AR installation partition (**\$INSTALL**) and **/tmp** are not at capacity.

## Resource Conflicts

Resource conflicts are a common reason for the Cisco Access Registrar 4.1 server failing to start. The most common resource conflicts are the following:

- Cisco Network Registrar is running on the Cisco Prime AR server
- Another application is also using ports 1645 and 1646
- A network management application is using the Sun SNMP Agent

## No Co-Existence With Cisco Network Registrar

Cisco Network Registrar cannot coexist on a machine running Cisco Prime AR for this reason. You can determine if CNR is running by entering the following command line in a terminal window:

```
pkginfo | grep -i "network registrar"
```



## Port Conflicts

The default ports used by the Cisco Prime AR server are ports 1645 and 1646. You should check to determine that no other applications are listening on the same ports as Cisco Prime AR.

You can check to see which TCP ports are in use by entering the following command line:

```
netstat -aP tcp
```

You can check to see which UDP ports are in use by entering the following command line:

```
netstat -aP udp
```



### Note

If you configure the Cisco Prime AR server to use ports other than the default, you will have to specifically add ports 1645 and 1646 if you want to also use those ports.

## Server Running Sun SNMP Agent

If you plan to use the Cisco Prime AR server's SNMP agent, you cannot use the Sun Microsystems SNMP agent that comes with the Solaris operating system.

## Cisco Prime Access Registrar Log Files

Examining the Cisco Prime AR log files can help you diagnose most Cisco Prime AR issues. By default, the Cisco Prime AR log files are located in `/opt/CSCOar/logs`. [Table 28-2](#) lists the Cisco Prime AR log files and the information stored in each log.

**Table 28-2** Cisco Prime AR Log Files

| Log File                         | Information Recorded                                                                                                                    |
|----------------------------------|-----------------------------------------------------------------------------------------------------------------------------------------|
| <code>agent_server_1_log</code>  | Log of the server agent process                                                                                                         |
| <code>ar-status</code>           | Log of Cisco Prime AR stop and start using the <code>arserver</code> utility                                                            |
| <code>aregcmd_log</code>         | Log of commands executed in <code>aregcmd</code> (very useful for tracing the steps that took place before a problem occurred)          |
| <code>config_mcd_1_log</code>    | Log of the mcd internal database                                                                                                        |
| <code>name_radius_1_log</code>   | Log of the radius server process                                                                                                        |
| <code>name_radius_1_trace</code> | Debugging output of RADIUS request processing (only generated when the trace level, set in <code>aregcmd</code> , is greater than zero) |

## Modifying File Sizes for Agent Server and MCD Server Logs

The two parameters added to the `car.conf` file under `$BASEDIR/conf` affect the `agent_server_logs` and `config_mcd_server_logs` files:

- `AGENT_SERVER_LOG_SIZE` (10 MB by default)

- AGENT\_SERVER\_LOG\_FILES (2 by default)

You will find these new parameters at the beginning of the **car.conf** file. When the log file size reaches the value set in AGENT\_SERVER\_LOG\_SIZE, a rollover of the **agent\_server\_log\_file** occurs. The value set in AGENT\_SERVER\_LOG\_FILES specifies the number of log files to be created.

## Using xtail to Monitor Log File Activity

A useful way of monitoring all of the log files is to run **xtail**, a utility provided with Cisco Prime AR. The **xtail** program monitors one or more files and displays all data written to a file since command invocation.

Run **xtail** in a dedicated terminal window. It is very useful for monitoring multiple logfiles simultaneously, such as with a command line like the following:

```
xtail $INSTALL/logs/*
```



**Note**

---

Cisco AR 4.1.5 and later include the millisecond field in the logs' timestamp.

---

## Modifying the Trace Level

By modifying the trace level, you can gather more detailed information in the log files about what is happening in the Cisco Prime AR server. There are five different trace levels. Each higher trace level also includes the information logged using lower trace levels. The different trace levels provide the following information:

- Level 0—No tracing occurs
- Level 1—Indicates when a packet is sent or received and when a status change occurs in a remote server (RADIUS Proxy and LDAP)
- Level 2—Information includes the following:
  - Which services and session managers are used to process
  - Which client and vendor objects are being used to process a packet
  - More details about remote servers (RADIUS Proxy and LDAP), packet transmission, and timeouts
  - Details about poorly-formed packets.
- Level 3—Information includes the following:
  - Tracing of errors in Tcl scripts when referencing invalid RADIUS attributes
  - Which scripts have been run
  - Details about local userlist processing
- Level 4—Information includes the following:
  - Advanced duplication detection processing
  - Details about creating, updating, and deleting sessions
  - Tracing of all APIs called during the running of a script
- Level 5—Provides information about policy engine operations

## Installation and Server Process Start-up

The installation process installs the Cisco Prime AR software to the specified installation directory and then starts the server processes. This process rarely fails but the following checks should always be performed:

- Ensure that there is an **installation success message** at the end of the **pkgadd** dialog, otherwise check the dialog for the problem
- Follow the installation instructions carefully especially when performing an upgrade. For example, when upgrading to 1.6R1, 1.6R2, or 1.6R3, a post-installation upgrade script needs to be run
- Pay attention to the information included in README files

At the end of a successful installation, **arstatus** should show the following four server processes:

```
> $INSTALL/usrbin/arstatus
AR RADIUS server running (pid: 6285)
AR MCD lock manager running (pid: 6284)
AR MCD server running (pid: 6283)
AR Server Agent running (pid: 6277)
```

If any of the above processes are not displayed, check the log file of the failed process to determine the reason. The MCD processes might fail to start if Cisco Network Registrar is installed on the same machine.

The manual method of starting and stopping the Cisco Prime AR processes is using the **arserver** utility.

To start Cisco Prime AR processes: **arserver start**

To stop Cisco Prime AR processes: **arserver stop**

To restart Cisco Prime AR processes: **arserver restart**

## aregcmd and Cisco Prime Access Registrar Configuration

While troubleshooting, you should always use the **aregcmd** command **trace** to turn on tracing. With tracing active, Cisco Prime AR generates debugging output to the log file **name\_radius\_1\_trace**. The syntax is:

```
trace [<server>] [<level>]
```

When you do not specify a server, Cisco Prime AR sets the trace level for all servers in the current cluster. When you do not specify a trace level, the currently set level is used. The default trace level is 0.

## Running and Stopped States

Cisco Prime AR can be in two states, running or stopped. In either state, all four Cisco Prime AR processes remain running. The state of Cisco Prime AR will be displayed when logging into **aregcmd** or by using the **aregcmd status** command:

```
status
```

```
Server 'Radius' is Running, its health is 10 out of 10\
```

The **start** and **stop** commands allow Cisco Prime AR to move between states. **Reload** is equivalent to a **stop** followed by a **start** if Cisco Prime AR is already running, and just a **start** if it is already stopped.

#### stop

```
Stopping Server 'Radius'...
Server 'Radius' is Stopped
```

#### start

```
Starting Server 'Radius'...
Server 'Radius' is Running, its health is 10 out of 10
```

#### reload

```
Reloading Server 'Radius'...
Server 'Radius' is Running, its health is 10 out of 10
```

During the transition from running to stopped, Cisco Prime AR stops processing new RADIUS requests and releases resources such as memory, network and database connections and open files.

During the transition from stopped to running, Cisco Prime AR reverses this process by opening a connection with its internal database, reading configuration data, claiming memory, establishing network connections, opening files, and initializing scripts. During this transition, problems can occur. Cisco Prime AR might fail to start and display the following:

#### reload

```
Reloading Server 'Radius'...
310 Command failed
```

Cisco Prime AR failed to move from stopped state to running:

#### status

```
Server 'Radius' is Stopped
```

This might occur for a number of reasons including the following:

- An invalid configuration
- Insufficient memory
- Listening ports already in use by another application
- Unable to open files
- Unable to initialize scripts

Check the **name\_radius\_1\_log** file for the one of these indications.

# RADIUS Request Processing

The main technique for troubleshooting RADIUS request processing in Cisco Prime AR is to examine the `name_radius_1_trace` log file with the trace level set to 5. Most issues are fairly self-explanatory. Some issues that can arise are as follows:

- Cisco Prime AR has marked a remote server as *down*
- A resource manager has run out of resources (for example, user or group session limit has been reached or no more IP addresses are available)
- A configuration error (such as an accounting service not being set)
- A run time error in a script

Some issues are not immediately evident from the log files though, such as the following:

- Failure to save or reload Cisco Prime AR after a configuration change
- Cisco Prime AR is not listening on the correct UDP ports for RADIUS requests

## Other Troubleshooting Techniques and Resources

### aregcmd Stats Command

The `aregcmd` command `stats` provides statistics on request processing.

--> `stats`

```
Global Statistics for Radius:
serverStartTime = Tue Oct 2 10:28:02 2008
serverResetTime = Tue Oct 2 20:25:12 2008
serverState = Running
totalPacketsInPool = 1024
totalPacketsReceived = 0
totalPacketsSent = 0
totalRequests = 0
totalResponses = 0
totalAccessRequests = 0
totalAccessAccepts = 0
totalAccessChallenges = 0
totalAccessRejects = 0
totalAccessResponses = 0
totalAccountingRequests = 0
totalAccountingResponses = 0
totalStatusServerRequests = 0
totalAscendIPAAAllocateRequests = 0
totalAscendIPAAAllocateResponses = 0
totalAscendIPAReleaseRequests = 0
totalAscendIPAReleaseResponses = 0
totalUSRNASRebootRequests = 0
totalUSRNASRebootResponses = 0
totalUSRResourceFreeRequests = 0
totalUSRResourceFreeResponses = 0
```

```
totalUSRQueryResourceRequests = 0
totalUSRQueryResourceResponses = 0
totalUSRQueryReclaimRequests = 0
totalUSRQueryReclaimResponses = 0
totalPacketsInUse = 0
totalPacketsDrained = 0
totalPacketsDropped = 0
totalPayloadDecryptionFailures = 0
```

## Core Files

A core file in the Cisco Prime AR installation directory is an indication that Cisco Prime AR has crashed and restarted. Check that the radius server process generated the core file using the UNIX **file** command:

```
> file core
```

```
core: ELF 32-bit MSB core file SPARC Version 1, from 'radius'
```

Check the timestamp on the core file and look for corresponding log messages in the **name\_radius\_1\_log** file in **\$INSTALL/logs**. The word *assertion* commonly appears in core messages. Try to establish what caused the problem and contact Cisco TAC.

## radclient

The Cisco Prime AR package provides a utility called **radclient** that allows RADIUS requests to be generated. Use **radclient** to test configurations and troubleshoot problems.

## Cisco Prime Access Registrar Replication

For more information about using Cisco Prime AR replication, see [Chapter 12, “Using Replication.”](#)

## Checking AR Server Health Status

To check the server’s health, use the **aregcmd status** command. The following issues decrement the server’s health:

- Multiple occurrences of Access-Request rejection



**Note** One of the parameters in the calculation of the Cisco Prime AR server’s health is the percentage of responses to Access-Accepts that are rejections. In a healthy environment, the rejection percentage will be fairly low. An extremely high percentage of rejections could be an indication of a Denial of Service attack.

- Configuration errors

- Running out of memory
- Errors reading from the network
- Dropping packets that cannot be read (because the server ran out of memory)
- Errors writing to the network.

Cisco Prime AR logs all of these conditions. Sending multiple successful responses to any packet, increments the server's health.







## APPENDIX **A**

# Cisco Prime Access Registrar Tcl, REX and Java Dictionaries

---

This appendix describes the Tcl and REX dictionaries that are used when writing Incoming or Outgoing scripts.

A dictionary is a data structure that contains key/value pairs. Two types of dictionaries exist: the Attribute dictionaries (used by the Request and Response dictionaries), and the Environment dictionary.

This section contains the dictionaries you reference when writing a Tcl script and the dictionaries you reference when you write a script using the shared libraries (REX—RADIUS EXtension).

This appendix section also describes the following Java attribute dictionary:

- [Tcl Attribute Dictionaries](#)
- [REX Attribute Dictionary](#)
- [Java Attribute Dictionary](#)

## Tcl Attribute Dictionaries

An *Attribute dictionary* is a dictionary in which the keys are constrained to be the names of attributes as defined in the Cisco Prime AR server configuration, and the values are the string representation of the legal values for that particular attribute. For example, IP addresses are specified by the dotted-decimal string representation of the address, and enumerated values are specified by the name of the enumeration. This means numbers are specified by the string representation of the number.

Attribute dictionaries have the unusual feature that there can be more than one instance of a particular key in the dictionary. These instances are ordered, with the first instance at index zero. Some of the methods of an Attribute dictionary allow an index to be specified to indicate a particular instance or position in the list of instances to be referenced. This section contains the following topics:

- [Attribute Dictionary Methods](#)
- [Tcl Environment Dictionary](#)

## Attribute Dictionary Methods

Attribute dictionaries use active commands, called *methods*, that allow you to change and access the values in the dictionaries. [Table A-1](#) lists of all of the methods you can use with the Request and Response dictionaries.

Table A-1 Tcl Attribute Dictionary Methods

| Name               | Syntax                                                                  | Description                                                                                                                                                                                                                                                                                                                                                                                                                                                                                                                                                                                                                                                                                               |
|--------------------|-------------------------------------------------------------------------|-----------------------------------------------------------------------------------------------------------------------------------------------------------------------------------------------------------------------------------------------------------------------------------------------------------------------------------------------------------------------------------------------------------------------------------------------------------------------------------------------------------------------------------------------------------------------------------------------------------------------------------------------------------------------------------------------------------|
| <b>addProfile</b>  | <b>\$dict addProfile</b> <profile> [ <i>&lt;mode&gt;</i> ]              | Copies all of the attributes in the profile <profile> into the dictionary. Note, <profile> must be the name of one of the profiles listed in the server configuration. When <mode> is not provided or when <mode> equals the special value <b>REPLACE</b> , any duplicate instances of the attributes in the dictionary are replaced with the attribute from <profile>. When <mode> is provided and equals the special value <b>APPEND</b> , new instances of the attributes are appended to the attributes already in the dictionary. When <mode> is provided and equals the special value <b>AUGMENT</b> , only add the attribute when it does not already exist.                                       |
| <b>clear</b>       | <b>\$dict clear</b>                                                     | Removes all entries from the dictionary.                                                                                                                                                                                                                                                                                                                                                                                                                                                                                                                                                                                                                                                                  |
| <b>containsKey</b> | <b>\$dict containsKey</b> <attribute>                                   | Returns 1 when the dictionary contains the attribute <attribute>, otherwise returns 0.                                                                                                                                                                                                                                                                                                                                                                                                                                                                                                                                                                                                                    |
| <b>firstKey</b>    | <b>\$dict firstKey</b>                                                  | Returns the name of the first attribute in the dictionary. Note, the attributes are not stored in a sorted order of name.                                                                                                                                                                                                                                                                                                                                                                                                                                                                                                                                                                                 |
| <b>get</b>         | <b>\$dict get</b> <attribute> [ <i>&lt;index&gt;</i> ] [ <b>bMore</b> ] | Returns the value of the <attribute> attribute from the dictionary, represented as a string. When the dictionary does not contain the <attribute>, an empty string is returned.<br><br>When <index> is provided, return the <index>'th instance of the attribute. Some attributes can appear more than once in the request (or response) packet. The <index> argument is used to select which instance to return.<br><br>When <b>bMore</b> is provided, the <b>get</b> method sets <b>bMore</b> to 1 when more attributes exist after the one returned, and to 0 otherwise. You can use this to determine whether another call to <b>get</b> should be made to retrieve other instances of the attribute. |
| <b>isEmpty</b>     | <b>\$dict isEmpty</b>                                                   | Returns 1 when the dictionary has no entries, otherwise returns 0.                                                                                                                                                                                                                                                                                                                                                                                                                                                                                                                                                                                                                                        |
| <b>log</b>         | <b>\$dict log</b> <level> <message> ...                                 | Outputs a message into the RADIUS server's logging system. The <level> should be either <b>LOG_ERROR</b> , <b>LOG_WARNING</b> , or <b>LOG_INFO</b> . The remaining arguments are concatenated together and sent to the logging system at the specified level.                                                                                                                                                                                                                                                                                                                                                                                                                                             |

Table A-1 Tcl Attribute Dictionary Methods (continued)

| Name           | Syntax                                                         | Description                                                                                                                                                                                                                                                                                                                                                                                                                                                                                                                                                                                                                                                |
|----------------|----------------------------------------------------------------|------------------------------------------------------------------------------------------------------------------------------------------------------------------------------------------------------------------------------------------------------------------------------------------------------------------------------------------------------------------------------------------------------------------------------------------------------------------------------------------------------------------------------------------------------------------------------------------------------------------------------------------------------------|
| <b>nextKey</b> | <b>\$dict nextKey</b>                                          | Returns the name of the next attribute in the dictionary that follows the attribute returned in the last call to <b>firstKey</b> or <b>nextKey</b> .                                                                                                                                                                                                                                                                                                                                                                                                                                                                                                       |
| <b>put</b>     | <b>\$dict put</b> <attribute> <value> [ <i>&lt;index&gt;</i> ] | Associates <value> with the attribute <attribute> in the dictionary. When <index> is not provided or when <index> equals the special value <b>REPLACE</b> , any existing instances of <attribute> are replaced with the single value. When <index> is provided and equals the special value <b>APPEND</b> , a new instance of <attribute> is appended to the end of the list of instances of the <attribute>. When <index> is provided and is a number, a new instance of <attribute> is inserted at the position indicated. When <index> is provided and equals the special value <b>AUGMENT</b> , only put the attribute when it does not already exist. |
| <b>remove</b>  | <b>\$dict remove</b> <attribute> [ <i>&lt;index&gt;</i> ]      | Removes the <attribute> attribute from the dictionary. When <index> is not provided or when <index> equals the special value <b>REMOVE_ALL</b> , remove any existing instances of <attribute>. When <index> is provided and is a number, remove the instance of <attribute> at the position indicated.<br><br>Always returns 1, even when the dictionary did not contain the <attribute> at that <index>.                                                                                                                                                                                                                                                  |
| <b>size</b>    | <b>\$dict size</b>                                             | Returns the number of entries in the dictionary.                                                                                                                                                                                                                                                                                                                                                                                                                                                                                                                                                                                                           |
| <b>trace</b>   | <b>\$dict trace</b> <level> <message> ...                      | Outputs a message into the packet tracing system used by the RADIUS server. At level 0, no tracing occurs. At level 1, only an indication the server received the packet and sent a reply is output. As the number gets higher, the amount of information output increases, until at level 4, where everything is traced as output. The remaining arguments are concatenated and sent to the tracing system at the specified level.                                                                                                                                                                                                                        |

## Tcl Environment Dictionary

A dictionary is a data structure that contains key/value pairs. An Environment dictionary is a dictionary in which the keys and values are constrained to be strings. The Tcl Environment dictionary is used to communicate information from the script to the server and from script to script within the processing of a particular request. Note, there can be only one instance of a key in the Environment dictionary.

Table A-2 lists of all the methods you can use with the Request and Response dictionaries.

**Table A-2** *Tcl Environment Dictionary Methods*

| Name               | Syntax                                                | Description                                                                                                                                                                                                                                                                                                                                                                                                                                           |
|--------------------|-------------------------------------------------------|-------------------------------------------------------------------------------------------------------------------------------------------------------------------------------------------------------------------------------------------------------------------------------------------------------------------------------------------------------------------------------------------------------------------------------------------------------|
| <b>clear</b>       | <b>\$dict clear</b>                                   | Removes all entries from the dictionary.                                                                                                                                                                                                                                                                                                                                                                                                              |
| <b>containsKey</b> | <b>\$dict containsKey &lt;key&gt;</b>                 | Returns 1 when the dictionary contains the <key> key, otherwise returns 0.                                                                                                                                                                                                                                                                                                                                                                            |
| <b>firstKey</b>    | <b>\$dict firstKey</b>                                | Returns the name of the first key in the dictionary. Note, the keys are not stored sorted by name.                                                                                                                                                                                                                                                                                                                                                    |
| <b>get</b>         | <b>\$dict get &lt;key&gt;</b>                         | Returns the value of <key> from the dictionary. When the dictionary does not contain the <key>, an empty string is returned.                                                                                                                                                                                                                                                                                                                          |
| <b>isEmpty</b>     | <b>\$dict isEmpty</b>                                 | Returns 1 when the dictionary has no entries, otherwise returns 0.                                                                                                                                                                                                                                                                                                                                                                                    |
| <b>log</b>         | <b>\$dict log &lt;level&gt; &lt;message&gt; ...</b>   | Outputs a message into the logging system used by the RADIUS server. <level> should be one of <b>LOG_ERROR</b> , <b>LOG_WARNING</b> , or <b>LOG_INFO</b> . The remaining arguments are concatenated together and sent to the logging system at the specified level.                                                                                                                                                                                   |
| <b>nextKey</b>     | <b>\$dict nextKey</b>                                 | Returns the name of the next key in the dictionary that follows the key returned in the last call to <b>firstKey</b> or <b>nextKey</b> .                                                                                                                                                                                                                                                                                                              |
| <b>put</b>         | <b>\$dict put &lt;key&gt; &lt;value&gt;</b>           | Associates <value> with the <key> key in the dictionary, replacing an existing instance of <key> with the new value.                                                                                                                                                                                                                                                                                                                                  |
| <b>remove</b>      | <b>\$dict remove &lt;key&gt;</b>                      | Removes the <key> key from the dictionary. Always returns 1, even when the dictionary did not contain the <key>.                                                                                                                                                                                                                                                                                                                                      |
| <b>size</b>        | <b>\$dict size</b>                                    | Returns the number of entries in the dictionary.                                                                                                                                                                                                                                                                                                                                                                                                      |
| <b>trace</b>       | <b>\$dict trace &lt;level&gt; &lt;message&gt; ...</b> | Outputs a message into the packet tracing system used by the RADIUS server. At level 0, no tracing occurs. At level 1, only an indication the server received the packet and sent a reply is output. As the number gets higher, the amount of information output is greater, until at level 4, where everything the server traces is output. The remaining arguments are concatenated together and sent to the tracing system at the specified level. |

# REX Attribute Dictionary

A dictionary is a data structure that contains key/value pairs. An Attribute dictionary is a dictionary in which the keys are constrained to be the attributes as defined in the RADIUS server configuration and the values are constrained to be legal values for that particular attribute. Attribute dictionaries have the unusual feature that there can be more than one instance of a particular key in the dictionary. These instances are ordered, with the first instance at index 0. Some of the methods of an Attribute dictionary allow an index to be specified to indicate a particular instance or position in the list of instances to be referenced.

When writing REX scripts, you can specify keys as the string representation of the name of the attribute or by type, which is a byte sequence defining the attribute. The values can also be specified as the string representation of the value or as the byte sequence, which is the attribute. These options mean some of these access methods have four different variations that are the combinations of string or type for the key, and string or bytes for the value. This section contains the following topics:

- [Attribute Dictionary Methods](#)
- [REX Environment Dictionary](#)

## Attribute Dictionary Methods

Attribute dictionaries use active commands, called *methods*, that allow you to change and access the values in the dictionaries.

[Table A-3](#) lists all of the methods you can use with the Request and Response dictionaries.

**Table A-3** REX Attribute Dictionary Methods

| Name                  | Syntax                                                                                                                             | Description                                                                                                                                                                                                                                                                                                                                                                                                                                                                                                                                                                                                                                                 |
|-----------------------|------------------------------------------------------------------------------------------------------------------------------------|-------------------------------------------------------------------------------------------------------------------------------------------------------------------------------------------------------------------------------------------------------------------------------------------------------------------------------------------------------------------------------------------------------------------------------------------------------------------------------------------------------------------------------------------------------------------------------------------------------------------------------------------------------------|
| <b>addProfile</b>     | <b>abool_t</b><br><b>pDict-&gt;addProfile(rex_AttributeDictionary_t* pDict, const char* &lt;pszProfile&gt;, int &lt;iMode&gt;)</b> | Copies all of the attributes in the <pszProfile> profile into the dictionary. Note, <pszProfile> must be the name of one of the profiles listed in the server configuration. When <iMode> equals the special value <b>REX_REPLACE</b> , it replaces any duplicate instances of the attributes in the dictionary with the attribute from the profile. When <iMode> equals the special value <b>REX_APPEND</b> , it appends a new instance of the attributes to any attributes already in the dictionary. When <iMode> equals the special value <b>REX_AUGMENT</b> , it adds the attribute in the dictionary, if it does not already exist in the dictionary. |
| <b>allocateMemory</b> | <b>void*</b><br><b>pDict-&gt;allocateMemory(rex_AttributeDictionary_t* pDict, unsigned int &lt;iSize&gt;)</b>                      | Allocates memory for use in scripts that persist only for the lifetime of this request. This memory is released when processing for this request is complete.                                                                                                                                                                                                                                                                                                                                                                                                                                                                                               |

Table A-3 REX Attribute Dictionary Methods (continued)

| Name                     | Syntax                                                                                                                                              | Description                                                                                                                                                                                                                                                                                                                                                                                                                                                                                                                                   |
|--------------------------|-----------------------------------------------------------------------------------------------------------------------------------------------------|-----------------------------------------------------------------------------------------------------------------------------------------------------------------------------------------------------------------------------------------------------------------------------------------------------------------------------------------------------------------------------------------------------------------------------------------------------------------------------------------------------------------------------------------------|
| <b>clear</b>             | <b>void</b><br><b>pDict-&gt;clear(rex_AttributeDictionary_t* pDict)</b>                                                                             | Removes all entries from the dictionary.                                                                                                                                                                                                                                                                                                                                                                                                                                                                                                      |
| <b>containsKey</b>       | <b>abool_t</b><br><b>pDict-&gt;containsKey(rex_AttributeDictionary_t* pDict, const char* &lt;pszAttribute&gt;)</b>                                  | Returns TRUE when the dictionary contains <pszAttribute>, otherwise returns FALSE.                                                                                                                                                                                                                                                                                                                                                                                                                                                            |
| <b>containsKeyByType</b> | <b>abool_t</b><br><b>pDict-&gt;containsKeyByType(rex_AttributeDictionary_t* pDict, const abytes_t* &lt;pAttribute&gt;)</b>                          | Returns TRUE when the dictionary contains <pAttribute>, otherwise returns FALSE.                                                                                                                                                                                                                                                                                                                                                                                                                                                              |
| <b>firstKey</b>          | <b>const char*</b><br><b>pDict-&gt;firstKey(rex_AttributeDictionary_t* pDict)</b>                                                                   | Returns the name of the first attribute in the dictionary. Note, the attributes are not stored in a sorted order of name.                                                                                                                                                                                                                                                                                                                                                                                                                     |
| <b>firstKeyByType</b>    | <b>const abytes_t*</b><br><b>pDict-&gt;firstKeyByType(rex_AttributeDictionary_t* pDict)</b>                                                         | Returns a pointer to the byte sequence defining the first attribute in the dictionary. Note, attributes are not stored sorted by name.                                                                                                                                                                                                                                                                                                                                                                                                        |
| <b>get</b>               | <b>const char*</b><br><b>pDict-&gt;get(rex_AttributeDictionary_t* pDict, const char* pszAttribute, int &lt;iIndex&gt;, abool_t* &lt;pbMore&gt;)</b> | Returns the value of the <iIndex>'d instance of the attribute from the dictionary, represented as a string. When the dictionary does not contain the attribute (or that many instances of the attribute), an empty string is returned.<br><br>When <pbMore> is non-zero, the <b>get</b> method sets <pbMore> to TRUE when more instances of the attribute exist after the one returned, and to FALSE otherwise. This can be used to determine whether another call to <b>get</b> should be made to retrieve other instances of the attribute. |

Table A-3 REX Attribute Dictionary Methods (continued)

| Name                  | Syntax                                                                                                                                                                                              | Description                                                                                                                                                                                                                                                                                                                                                                                                                                                                                                                                              |
|-----------------------|-----------------------------------------------------------------------------------------------------------------------------------------------------------------------------------------------------|----------------------------------------------------------------------------------------------------------------------------------------------------------------------------------------------------------------------------------------------------------------------------------------------------------------------------------------------------------------------------------------------------------------------------------------------------------------------------------------------------------------------------------------------------------|
| <b>getBytes</b>       | <b>const abytes_t*</b><br><b>pDict-&gt;getBytes(rex_AttributeDictionary_t* pDict, const char*</b><br><b>pszAttribute, int &lt;iIndex&gt;, abool_t*</b><br><b>&lt;pbMore&gt;)</b>                    | Returns the value of the <iIndex>'d instance of the attribute from the dictionary, as a sequence of bytes. When the dictionary does not contain the attribute (or that many instances of the attribute), 0 is returned.<br><br>When <pbMore> is non-zero, the <b>getBytes</b> method sets <pbMore> to TRUE when more instances of the attribute exist after the one returned, and to FALSE otherwise. This can be used to determine whether another call to <b>getBytes</b> should be made to retrieve other instances of the attribute.                 |
| <b>getBytesByType</b> | <b>const abytes_t*</b><br><b>pDict-&gt;getBytesByType</b><br><b>(rex_AttributeDictionary_t* pDict,</b><br><b>const abytes_t* pAttribute, int</b><br><b>&lt;iIndex&gt;, abool_t* &lt;pbMore&gt;)</b> | Returns the value of the <iIndex>'d instance of the attribute from the dictionary, as a sequence of bytes. When the dictionary does not contain the attribute (or that many instances of the attribute), 0 is returned instead.<br><br>When <pbMore> is non-zero, sets the variable pointed to TRUE when more instances of the attribute exist after the one returned, and to FALSE otherwise. This can be used to determine whether another call to <b>get</b> should be made to retrieve other instances of the attribute.                             |
| <b>getByType</b>      | <b>const char*</b><br><b>pDict-&gt;get(rex_AttributeDictionary_t* pDict, const abytes_t*</b><br><b>&lt;pszAttribute&gt;, int &lt;iIndex&gt;,</b><br><b>abool_t* &lt;pbMore&gt;)</b>                 | Returns the value of the <iIndex>'d instance of the attribute from the dictionary, as represented as a string. When the dictionary does not contain the attribute (or that many instances of the attribute), returns an empty string.<br><br>When <pbMore> is non-zero, the <b>getByType</b> method sets <pbMore> to TRUE when more instances of the attribute exist after the one returned, and to FALSE otherwise. This can be used to determine whether another call to <b>getByType</b> should be made to retrieve other instances of the attribute. |
| <b>getType</b>        | <b>const char*</b><br><b>pDict-&gt;getByType(rex_AttributeDictionary_t* pDict, const abytes_t*</b><br><b>&lt;pAttribute&gt;)</b>                                                                    | Returns a pointer to the byte sequence defining the attribute, when the attribute name matches a configured attribute, zero otherwise.                                                                                                                                                                                                                                                                                                                                                                                                                   |

Table A-3 REX Attribute Dictionary Methods (continued)

| Name          | Syntax                                                                                                                                                 | Description                                                                                                                                                                                                                                                                                                                                                                                                                                                                                                                                                                                                                                                                                                                                                                                                                                                              |
|---------------|--------------------------------------------------------------------------------------------------------------------------------------------------------|--------------------------------------------------------------------------------------------------------------------------------------------------------------------------------------------------------------------------------------------------------------------------------------------------------------------------------------------------------------------------------------------------------------------------------------------------------------------------------------------------------------------------------------------------------------------------------------------------------------------------------------------------------------------------------------------------------------------------------------------------------------------------------------------------------------------------------------------------------------------------|
| isEmpty       | <pre>abool_t pDict-&gt;isEmpty(rex_AttributeDictionary_t* pDict)</pre>                                                                                 | Returns TRUE when the dictionary has 0 entries, FALSE otherwise.                                                                                                                                                                                                                                                                                                                                                                                                                                                                                                                                                                                                                                                                                                                                                                                                         |
| log           | <pre>abool_t pDict-&gt;log(rex_AttributeDictionary_t* pDict, int &lt;iLevel&gt;, const char* &lt;pszFormat&gt;, ...)</pre>                             | Outputs a message into the logging system used by the RADIUS server. <iLevel> should be one of <b>REX_LOG_ERROR</b> , <b>REX_LOG_WARNING</b> , or <b>REX_LOG_INFO</b> . The <b>pszFormat</b> argument is treated as a <b>printf</b> -style format string, and it, along with the remaining arguments, are formatted and sent to the logging system at the specified level.                                                                                                                                                                                                                                                                                                                                                                                                                                                                                               |
| nextKey       | <pre>const char* pDict-&gt;nextKey(rex_AttributeDictionary_t* pDict)</pre>                                                                             | Returns the name of the <i>next</i> attribute in the dictionary that follows the attribute returned in the last call to <b>firstKey</b> or <b>nextKey</b> .                                                                                                                                                                                                                                                                                                                                                                                                                                                                                                                                                                                                                                                                                                              |
| nextKeyByType | <pre>const abytes_t* pDict-&gt; nextKeyByType(rex_AttributeDictionary_t* pDict)</pre>                                                                  | Returns a pointer to the byte sequence defining the next attribute in the dictionary that follows the attribute returned in the last call to <b>firstKeyByType</b> or <b>nextKeyByType</b> .                                                                                                                                                                                                                                                                                                                                                                                                                                                                                                                                                                                                                                                                             |
| put           | <pre>abool_t pDict-&gt;put(rex_AttributeDictionary_t* pDict, const char* &lt;pszAttribute&gt;, const char* &lt;pszValue&gt;, int &lt;iIndex&gt;)</pre> | Converts <pszValue> to a sequence of bytes, according to the definition of <pszAttribute> in the server configuration. Associates that sequence of bytes with <pszAttribute> in the dictionary. When <iIndex> equals the special value <b>REX_REPLACE</b> , it replaces any existing instances of <pszAttribute> with a single value. When <iIndex> equals the special value <b>REX_APPEND</b> , it appends a new instance of <pszAttribute> to the end of the list of existing instances of <pszAttribute>. Otherwise, a new instance of <pszAttribute> is inserted at the position indicated. This method returns TRUE unless <pszAttribute> does not match any configured attributes or the value could not be converted to a legal value. When <iIndex> equals the special value <b>REX_AUGMENT</b> , only <b>put</b> <pszAttribute> when it does not already exist. |



Table A-3 REX Attribute Dictionary Methods (continued)

| Name           | Syntax                                                                                                                                                                                              | Description                                                                                                                                                                                                                                                                                                                                                                                                                                                                                                                                                                                                                                                                                                                                                                  |
|----------------|-----------------------------------------------------------------------------------------------------------------------------------------------------------------------------------------------------|------------------------------------------------------------------------------------------------------------------------------------------------------------------------------------------------------------------------------------------------------------------------------------------------------------------------------------------------------------------------------------------------------------------------------------------------------------------------------------------------------------------------------------------------------------------------------------------------------------------------------------------------------------------------------------------------------------------------------------------------------------------------------|
| putBytes       | <pre> <b>abool_t</b> <b>pDict-&gt;putBytes(rex_AttributeDict</b> <b>ionary_t* pDict, const char*</b> <b>&lt;pszAttribute&gt;, const abytes_t*</b> <b>&lt;pValue&gt;, int &lt;iIndex&gt;)</b> </pre> | <p>Associates &lt;pValue&gt; with the attribute &lt;pszAttribute&gt; in the dictionary. When &lt;iIndex&gt; equals the special value <b>REX_REPLACE</b>, it replaces any existing instances of the &lt;pszAttribute&gt; with a single new value. When &lt;iIndex&gt; equals the special value <b>REX_APPEND</b>, it appends a new instance of &lt;pszAttribute&gt; to the end of the list of existing instances of &lt;pszAttribute&gt;. When &lt;iIndex&gt; equals the special value <b>REX_AUGMENT</b>, only put the &lt;pszAttribute&gt; when it does not already exist. Otherwise, a new instance of &lt;pszAttribute&gt; is inserted at the position indicated.</p> <p>This method returns TRUE unless the attribute name does not match any configured attributes.</p> |
| putBytesByType | <pre> <b>abool_t</b> <b>pDict-&gt;putBytesByType(rex_AttributeDictionary_t*</b> <b>pDict, const abytes_t* &lt;pAttribute&gt;, const</b> <b>abytes_t* &lt;pValue&gt;, int &lt;iIndex&gt;)</b> </pre> | <p>Associates &lt;pValue&gt; with the attribute &lt;pAttribute&gt; in the dictionary. When &lt;iIndex&gt; equals the special value <b>REX_REPLACE</b>, it replaces any existing instances of &lt;pAttribute&gt; with the new value. When &lt;iIndex&gt; equals the special value <b>REX_APPEND</b>, it appends a new instance of &lt;pAttribute&gt; to the end of the list of existing instances of &lt;pAttribute&gt;. When &lt;iIndex&gt; equals the special value <b>REX_AUGMENT</b>, only put &lt;pAttribute&gt; when it does not already exist. Otherwise, insert a new instance of &lt;pAttribute&gt; at the position indicated.</p> <p>This method returns TRUE unless the attribute name does not match any configured attributes.</p>                               |

Table A-3 REX Attribute Dictionary Methods (continued)

| Name         | Syntax                                                                                                                                                                           | Description                                                                                                                                                                                                                                                                                                                                                                                                                                                                                                                                                                                                                                                                                                                                                                                                                                                                              |
|--------------|----------------------------------------------------------------------------------------------------------------------------------------------------------------------------------|------------------------------------------------------------------------------------------------------------------------------------------------------------------------------------------------------------------------------------------------------------------------------------------------------------------------------------------------------------------------------------------------------------------------------------------------------------------------------------------------------------------------------------------------------------------------------------------------------------------------------------------------------------------------------------------------------------------------------------------------------------------------------------------------------------------------------------------------------------------------------------------|
| putByType    | <pre> <b>abool_t</b> <b>pDict-&gt;putByType(rex_AttributeDictionary_t* pDict, const abytes_t* &lt;pszAttribute&gt;, const char* &lt;pszValue&gt;, int &lt;iIndex&gt;)</b> </pre> | <p>Converts <i>&lt;pszValue&gt;</i> to a sequence of bytes, according to the definition of <i>&lt;pszAttribute&gt;</i> in the server configuration. Associates that sequence of bytes with <i>&lt;pszAttribute&gt;</i> in the dictionary. When <i>&lt;iIndex&gt;</i> equals the special value <b>REX_REPLACE</b>, it replaces any existing instances of <i>&lt;pszAttribute&gt;</i> with a single new value. When <i>&lt;iIndex&gt;</i> equals the special value <b>REX_APPEND</b>, it appends a new instance of <i>&lt;pszAttribute&gt;</i> to the end of the list of existing instances of <i>&lt;pszAttribute&gt;</i>. Otherwise, it inserts a new instance of <i>&lt;pszAttribute&gt;</i> at the position indicated. This method returns TRUE unless <i>&lt;pszAttribute&gt;</i> does not match any configured attributes, or the value could not be converted to a legal value.</p> |
| remove       | <pre> <b>abool_t</b> <b>pDict-&gt;remove(rex_AttributeDictionary_t* pDict, const char* &lt;pszAttribute&gt;, int &lt;iIndex&gt;)</b> </pre>                                      | <p>Removes the <i>&lt;pszAttribute&gt;</i> from the dictionary. When <i>&lt;iIndex&gt;</i> equals the special value <b>REX_REMOVE_ALL</b>, removes any existing instances of <i>&lt;pszAttribute&gt;</i>. Otherwise, it removes the instance of <i>&lt;pszAttribute&gt;</i> at the position indicated. Returns TRUE, even when the dictionary did not contain <i>&lt;pszAttribute&gt;</i> at the <i>&lt;iIndex&gt;</i>, unless <i>&lt;pszAttribute&gt;</i> does not match any configured attribute.</p>                                                                                                                                                                                                                                                                                                                                                                                  |
| removeByType | <pre> <b>abool_t</b> <b>pDict-&gt;removeByType(rex_AttributeDictionary_t* pDict, const abytes_t* &lt;pAttribute&gt;, int &lt;iIndex&gt;)</b> </pre>                              | <p>Removes the <i>&lt;pAttribute&gt;</i> from the dictionary. When <i>&lt;iIndex&gt;</i> equals the special value <b>REX_REMOVE_ALL</b>, it removes any existing instances of <i>&lt;pszAttribute&gt;</i>. Otherwise, the instance of <i>&lt;pAttribute&gt;</i> at the position indicated is removed. Always returns TRUE, even when the dictionary did not contain <i>&lt;pAttribute&gt;</i> at the <i>&lt;iIndex&gt;</i>.</p>                                                                                                                                                                                                                                                                                                                                                                                                                                                          |
| reschedule   | <pre> <b>abool_t</b> <b>pDict-&gt;reschedule(rex_AttributeDictionary_t* pDict)</b> </pre>                                                                                        | <p>Enables control over asynchronous activities. It enables you to collect similar activities and mark them as pending. You can then process them and reschedule them. You can only use this attribute with multithreaded services. Use caution when employing this method.</p>                                                                                                                                                                                                                                                                                                                                                                                                                                                                                                                                                                                                          |

Table A-3 REX Attribute Dictionary Methods (continued)

| Name  | Syntax                                                                                                                             | Description                                                                                                                                                                                                                                                                                                                                                                                                                    |
|-------|------------------------------------------------------------------------------------------------------------------------------------|--------------------------------------------------------------------------------------------------------------------------------------------------------------------------------------------------------------------------------------------------------------------------------------------------------------------------------------------------------------------------------------------------------------------------------|
| size  | <b>int</b><br><b>pDict-&gt;size(rex_AttributeDictionary_t* pDict)</b>                                                              | Returns the number of entries in the dictionary.                                                                                                                                                                                                                                                                                                                                                                               |
| trace | <b>abool_t</b><br><b>pDict-&gt;trace(rex_AttributeDictionary_t* pDict, int &lt;iLevel&gt;, const char* &lt;pszFormat&gt;, ...)</b> | Outputs a message into the packet tracing system used by the RADIUS server. At level 0, no tracing occurs. At level 1, only an indication the packet was received and a reply was sent is output. As the number gets higher, the amount of information output is greater, until at level 4, where everything traceable is output. The remaining arguments are formatted and sent to the tracing system at the specified level. |

## REX Environment Dictionary

A dictionary is a data structure that contains key/value pairs. An Environment dictionary is a dictionary in which the keys and values are constrained to be strings. The REX Environment dictionary is used to communicate information from the script to the server and from script to script within the processing of a particular request. Note, there can be only one instance of a key in the Environment dictionary.

## REX Environment Dictionary Methods

The Environment dictionary uses active commands, called *methods*, to allow you to change and access the values in the dictionary. Table A-4 lists all of the methods you can use with the REX Environment dictionary.

Table A-4 REX Environment Dictionary Methods

| Name           | Syntax                                                                                                          | Description                                                                                                                                                  |
|----------------|-----------------------------------------------------------------------------------------------------------------|--------------------------------------------------------------------------------------------------------------------------------------------------------------|
| allocateMemory | <b>void*</b><br><b>pDict-&gt;allocateMemory(rex_EnvironmentDictionary_t* pDict, unsigned int &lt;iSize&gt;)</b> | Allocate memory for use in scripts that persist only for the lifetime of this request. This memory is released when processing for this request is complete. |
| clear          | <b>void</b><br><b>pDict-&gt;clear(rex_EnvironmentDictionary_t* pDict)</b>                                       | Removes all entries from the dictionary.                                                                                                                     |
| containsKey    | <b>abool_t</b><br><b>pDict-&gt;containsKey(rex_EnvironmentDictionary_t* pDict, const char* &lt;pszKey&gt;)</b>  | Returns TRUE when the dictionary contains <pszKey>, otherwise returns FALSE.                                                                                 |
| firstKey       | <b>const char*</b><br><b>pDict-&gt;firstKey(rex_EnvironmentDictionary_t* pDict)</b>                             | Returns the name of the first key in the dictionary. Note, the keys are not stored sorted by name.                                                           |

Table A-4 REX Environment Dictionary Methods (continued)

| Name              | Syntax                                                                                                                               | Description                                                                                                                                                                                                                                                                                                                                                           |
|-------------------|--------------------------------------------------------------------------------------------------------------------------------------|-----------------------------------------------------------------------------------------------------------------------------------------------------------------------------------------------------------------------------------------------------------------------------------------------------------------------------------------------------------------------|
| <b>get</b>        | <b>const char*</b><br><b>pDict-&gt;get(rex_EnvironmentDictionary_t* pDict, const char* &lt;pszKey&gt;)</b>                           | Returns the value associated with <pszKey> from the dictionary. When the dictionary does not contain <pszKey>, an empty string is returned.                                                                                                                                                                                                                           |
| <b>isEmpty</b>    | <b>abool_t</b><br><b>pDict-&gt;isEmpty(rex_EnvironmentDictionary_t* pDict)</b>                                                       | Returns TRUE when the dictionary has 0 entries, FALSE otherwise.                                                                                                                                                                                                                                                                                                      |
| <b>log</b>        | <b>abool_t</b><br><b>pDict-&gt;log(rex_EnvironmentDictionary_t* pDict, int &lt;iLevel&gt;, const char* &lt;pszFormat&gt;, ...)</b>   | Outputs a message into the logging system used by the RADIUS server. <iLevel> should be one of <b>REX_LOG_ERROR</b> , <b>REX_LOG_WARNING</b> , or <b>REX_LOG_INFO</b> . The <pszFormat> argument is treated as a <b>printf</b> -style format string, and it, along with the remaining arguments, are formatted and sent to the logging system at the specified level. |
| <b>nextKey</b>    | <b>const char*</b><br><b>pDict-&gt;nextKey(rex_EnvironmentDictionary_t* pDict)</b>                                                   | Returns the name of the next key in the dictionary that follows the key returned in the last call to <b>firstKey</b> or <b>nextKey</b> .                                                                                                                                                                                                                              |
| <b>put</b>        | <b>abool_t</b><br><b>pDict-&gt;put(rex_EnvironmentDictionary_t* pDict, const char* &lt;pszValue&gt;, const char* &lt;pszKey&gt;)</b> | Associates the value with <pszKey> in the dictionary, replacing any existing instance of <pszKey> with the new <pszValue>.                                                                                                                                                                                                                                            |
| <b>remove</b>     | <b>abool_t</b><br><b>pDict-&gt;remove(rex_EnvironmentDictionary_t* pDict, const char* &lt;pszKey&gt;)</b>                            | Removes <pszKey> and the associated value from the dictionary. Always returns TRUE, even when the dictionary did not contain <pszKey>                                                                                                                                                                                                                                 |
| <b>reschedule</b> | <b>abool_t</b><br><b>pDict-&gt;reschedule(rex_AttributeDictionary_t* pDict)</b>                                                      | Enables control over asynchronous activities. It enables you to collect similar activities and mark them as pending. You can then process them and reschedule them. You can only use this attribute with multithreaded services. Use caution when employing this method.                                                                                              |

Table A-4 REX Environment Dictionary Methods (continued)

| Name  | Syntax                                                                                                                               | Description                                                                                                                                                                                                                                                                                                                                                                                                                    |
|-------|--------------------------------------------------------------------------------------------------------------------------------------|--------------------------------------------------------------------------------------------------------------------------------------------------------------------------------------------------------------------------------------------------------------------------------------------------------------------------------------------------------------------------------------------------------------------------------|
| size  | <b>int</b><br><b>pDict-&gt;size(rex_EnvironmentDictionary_t* pDict)</b>                                                              | Returns the number of entries in the dictionary.                                                                                                                                                                                                                                                                                                                                                                               |
| trace | <b>abool_t</b><br><b>pDict-&gt;trace(rex_EnvironmentDictionary_t* pDict, int &lt;iLevel&gt;, const char* &lt;pszFormat&gt;, ...)</b> | Outputs a message into the packet tracing system used by the RADIUS server. At level 0, no tracing occurs. At level 1, only an indication the packet was received and a reply was sent is output. As the number gets higher, the amount of information output is greater, until at level 4, where everything traceable is output. The remaining arguments are formatted and sent to the tracing system at the specified level. |

## Java Attribute Dictionary

The AttributeDictionary is a dictionary of attributes, where the keys are the attribute types and the values are the data fields in the attribute. Both keys and values must conform to the definition of attributes in the server's Attribute Dictionary. Keys (types) can be either strings or byte arrays. If strings, they are the names of attributes. If byte arrays, they are the binary type. The type associated with a name can be retrieved by calling the static method `getType(java.lang.String)`. Using byte arrays is slightly more efficient - methods that take String keys must do the mapping from String to byte array in the course of executing the method. Similarly, values can be strings or byte arrays. Again, string values are converted to the appropriate binary representation when stored in an AttributeDictionary and back again when retrieved into a string variable.

Keys in an AttributeDictionary can be associated with multiple values. Each of the values associated with a key is ordered with an integer index denoting its position in the list of values. Given an AttributeDictionary, a key and an index, each value associated with a key can be looked up. This section contains the following topics:

- [Java Environment Dictionary Methods](#)
- [Interface Extension Methods](#)
- [Interface Extensionforsession Methods](#)
- [Interface Extensionwithinitialization Methods](#)
- [Interface Extensionforsessionwithinitialization Methods](#)
- [Variables in the Marker Extension Interface](#)
- [Session Record Methods](#)

## Java Attribute Dictionary Methods

Attribute dictionaries use active commands called methods, that allow you to change and access the values in the dictionaries.

Table A-5 lists all of the methods you can use with the Request and Response dictionaries.

**Table A-5** Java Attribute Dictionary Methods

| Name        | Syntax                                                                            | Description                                                                                                                                                                                                                                                                                                                                                                                                                                                                                                                                                                                                                                                  |
|-------------|-----------------------------------------------------------------------------------|--------------------------------------------------------------------------------------------------------------------------------------------------------------------------------------------------------------------------------------------------------------------------------------------------------------------------------------------------------------------------------------------------------------------------------------------------------------------------------------------------------------------------------------------------------------------------------------------------------------------------------------------------------------|
| size        | public int size()                                                                 | Returns the number of distinct keys in the dictionary.                                                                                                                                                                                                                                                                                                                                                                                                                                                                                                                                                                                                       |
| isEmpty     | public boolean isEmpty()                                                          | Tests if the dictionary contains any entries.                                                                                                                                                                                                                                                                                                                                                                                                                                                                                                                                                                                                                |
| clear       | public void clear()                                                               | Removes all entries from the dictionary.                                                                                                                                                                                                                                                                                                                                                                                                                                                                                                                                                                                                                     |
| containsKey | public boolean<br>containsKey(java.lang.String<br>key)                            | Returns true if an entry exists for key.                                                                                                                                                                                                                                                                                                                                                                                                                                                                                                                                                                                                                     |
| get         | public java.lang.String<br>get(java.lang.String key)                              | Returns the first value associated with the key.                                                                                                                                                                                                                                                                                                                                                                                                                                                                                                                                                                                                             |
| get         | public java.lang.String<br>get(java.lang.String key, int<br>index)                | Returns the value at position index associated with the key.                                                                                                                                                                                                                                                                                                                                                                                                                                                                                                                                                                                                 |
| put         | public boolean<br>put(java.lang.String key,<br>java.lang.String value)            | Associates key with a value. Any existing values associated with the key are removed before adding this association.                                                                                                                                                                                                                                                                                                                                                                                                                                                                                                                                         |
| put         | public boolean<br>put(java.lang.String key,<br>java.lang.String value, int index) | Associates key with a value depending on the value of index.<br><br>If index equals <b>Extension.EXT_REPLACE</b> , any existing values are removed before adding this new association. If index equals <b>Extension.EXT_APPEND</b> , a new value is added at the end of the list of existing values. If index equals <b>Extension.EXT_AUGMENT</b> , the new association is only made if the dictionary does not already have an entry for key. If index is a number greater than or equal to 0 and less than the number of entries in the list, the value is inserted at that position in the list. Otherwise, the value is appended at the end of the list. |
| getBytes    | public byte[]<br>getBytes(java.lang.String key)                                   | Returns the first value associated with the key.                                                                                                                                                                                                                                                                                                                                                                                                                                                                                                                                                                                                             |
| getBytes    | public byte[]<br>getBytes(java.lang.String key,<br>int index)                     | Returns the value at position index associated with key.                                                                                                                                                                                                                                                                                                                                                                                                                                                                                                                                                                                                     |
| putBytes    | public boolean<br>putBytes(java.lang.String key,<br>byte[] value)                 | Associates key with value. Any existing values associated with key are removed before adding this association.                                                                                                                                                                                                                                                                                                                                                                                                                                                                                                                                               |

Table A-5 Java Attribute Dictionary Methods (continued)

| Name       | Syntax                                                                                            | Description                                                                                                                                                                                                                                                                                                                                                                                                                                                                                                                                                                                                                                                  |
|------------|---------------------------------------------------------------------------------------------------|--------------------------------------------------------------------------------------------------------------------------------------------------------------------------------------------------------------------------------------------------------------------------------------------------------------------------------------------------------------------------------------------------------------------------------------------------------------------------------------------------------------------------------------------------------------------------------------------------------------------------------------------------------------|
| putBytes   | <b>public boolean</b><br><b>putBytes(java.lang.String key,</b><br><b>byte[] value, int index)</b> | Associates key with a value depending on the value of index.<br><br>If index equals <b>Extension.EXT_REPLACE</b> , any existing values are removed before adding this new association. If index equals <b>Extension.EXT_APPEND</b> , a new value is added at the end of the list of existing values. If index equals <b>Extension.EXT_AUGMENT</b> , the new association is only made if the dictionary does not already have an entry for key. If index is a number greater than or equal to 0 and less than the number of entries in the list, the value is inserted at that position in the list. Otherwise, the value is appended at the end of the list. |
| remove     | <b>public void</b><br><b>remove(java.lang.String key)</b>                                         | Removes key (and all corresponding values) from the dictionary. This method does nothing if key is not in the dictionary.                                                                                                                                                                                                                                                                                                                                                                                                                                                                                                                                    |
| remove     | <b>public void</b><br><b>remove(java.lang.String key, int index)</b>                              | Removes value at the position index that is associated with key. If the index equals <b>Extension.EXT_REMOVE_ALL</b> or if the value being removed is the last value associated with key, the key is removed from the dictionary. This method does nothing if key is not in the dictionary.                                                                                                                                                                                                                                                                                                                                                                  |
| addProfile | <b>public boolean</b><br><b>addProfile(java.lang.String</b><br><b>profileName)</b>                | Adds all the attributes contained in the specified profile into the dictionary. Any existing attributes that have the same keys as attributes in the profile are removed before adding the new attributes.                                                                                                                                                                                                                                                                                                                                                                                                                                                   |
| Addprofile | <b>boolean</b><br><b>addProfile(java.lang.String</b><br><b>profileName, int mode)</b>             | Adds all the attributes contained in the specified profile into the dictionary. Any existing attributes that have the same keys as attributes in the Profile will be treated depending on the mode value. For each attribute in the Profile, if mode equals <b>Extension.EXT_REPLACE</b> , any values associated with the attribute in the dictionary are removed before adding the attribute. If index equals <b>Extension.EXT_APPEND</b> , a new value is added at the end of the list of existing values. If index equals <b>Extension.EXT_AUGMENT</b> , a new value is added only if the dictionary does not already have an entry for the given key.    |
| getType    | <b>public static byte[]</b><br><b>getType(java.lang.String key)</b>                               | Takes the name of the attribute (as a string) and returns the binary form of key.                                                                                                                                                                                                                                                                                                                                                                                                                                                                                                                                                                            |

**Table A-5** *Java Attribute Dictionary Methods (continued)*

| Name              | Syntax                                               | Description                                                                                                                                                                                                                                                                                            |
|-------------------|------------------------------------------------------|--------------------------------------------------------------------------------------------------------------------------------------------------------------------------------------------------------------------------------------------------------------------------------------------------------|
| <b>keys</b>       | <b>public java.util.Enumeration<br/>keys()</b>       | Returns an enumeration of the keys in the dictionary. The general contract for the keys method is that an Enumeration object is returned that will generate all the keys for which the dictionary contains entries.                                                                                    |
| <b>elements</b>   | <b>public java.util.Enumeration<br/>elements()</b>   | Returns an enumeration of the entries in the dictionary. The general contract for the elements method is that an Enumeration object is returned that will generate all the elements contained in entries in the dictionary. Keys with multiple values will result in multiple elements being returned. |
| <b>keysByType</b> | <b>public java.util.Enumeration<br/>keysByType()</b> | Returns an enumeration of the keys in the dictionary. The general contract for the keys method is that an Enumeration object is returned that will generate all the keys for which the dictionary contains entries.                                                                                    |

## Java Environment Dictionary

The Environment Dictionary can be used to store information between Extensions invoked subsequently on a given request or can be used to pass information between the Extension and the server properly.

The Environment Dictionary maps keys to values, where the keys and values are strings. In any one instance of the Environment Dictionary, every key is associated with at most one value. Given an Environment Dictionary and a key, the associated value can be looked up. Any non-null string can be used as a key and value.

## Java Environment Dictionary Methods

The Environment dictionary uses active commands called methods, to allow you to change and access the values in the dictionary. [Table A-6](#) lists all of the methods you can use with the java Environment dictionary.

**Table A-6** *Java Environment Dictionary Methods*

| Name               | Syntax                                                       | Description                                                      |
|--------------------|--------------------------------------------------------------|------------------------------------------------------------------|
| <b>size</b>        | <b>public int size()</b>                                     | Returns the number of entries (distinct keys) in the dictionary. |
| <b>isEmpty</b>     | <b>public boolean isEmpty()</b>                              | Tests if the dictionary contains no entries.                     |
| <b>clear</b>       | <b>public void clear()</b>                                   | Removes all entries from the dictionary.                         |
| <b>containsKey</b> | <b>public boolean<br/>containsKey(java.lang.String key)</b>  | Returns true if the dictionary contains an entry for key.        |
| <b>get</b>         | <b>public java.lang.String<br/>get(java.lang.String key)</b> | Returns the value associated with key in the dictionary.         |



**Table A-6** *Java Environment Dictionary Methods (continued)*

| <b>Name</b>       | <b>Syntax</b>                                                           | <b>Description</b>                                                                                                                                                                                                          |
|-------------------|-------------------------------------------------------------------------|-----------------------------------------------------------------------------------------------------------------------------------------------------------------------------------------------------------------------------|
| <b>put</b>        | <b>public boolean put(java.lang.String key, java.lang.String value)</b> | Associates key with value.                                                                                                                                                                                                  |
| <b>remove</b>     | <b>public void remove(java.lang.String key)</b>                         | Removes key (and its corresponding value) from this dictionary. This method does nothing if key is not in the dictionary.                                                                                                   |
| <b>keys</b>       | <b>public java.util.Enumeration keys()</b>                              | Returns an enumeration of the keys in the dictionary. The general contract for the keys method is that an Enumeration object is returned that will generate all the keys for which the dictionary contains entries.         |
| <b>elements</b>   | <b>public java.util.Enumeration elements()</b>                          | Returns an enumeration of the entries in the dictionary. The general contract for the elements method is that an Enumeration object is returned that will generate all the elements contained in entries in the dictionary. |
| <b>log</b>        | <b>public static void log(int level, java.lang.String message)</b>      | Prints a message in the server log at the specified level.                                                                                                                                                                  |
| <b>trace</b>      | <b>public void trace(int level, java.lang.String message)</b>           | Prints a message in the server trace file at the specified level.                                                                                                                                                           |
| <b>reschedule</b> | <b>public void reschedule()</b>                                         | Informs the server that it should take back ownership of the request associated with the dictionary and continue processing it.                                                                                             |

## Interface Extension

Classes that are going to be used as scripts or services from Access Registrar must implement the Extension interface. When a Java scripting point or service is encountered during the processing of a request, the server will call the runExtension method defined in this interface and implemented by the appropriate class.

## Interface Extension Methods

Table A-7 lists the methods you can use for interface extension

**Table A-7** Interface Extension Methods

| Name                | Syntax                                                                                                                                                                      | Description                                                                                                                                                                                                                                                                                                                                                                                                                                                                                                                                                                                                                                                                                                                                                                                                                                                                                                                                                                                                                                                                                                                                                                                                                                                                                                                                                                                                                                                                                                                                                                                                                                                                                                                                                                               |
|---------------------|-----------------------------------------------------------------------------------------------------------------------------------------------------------------------------|-------------------------------------------------------------------------------------------------------------------------------------------------------------------------------------------------------------------------------------------------------------------------------------------------------------------------------------------------------------------------------------------------------------------------------------------------------------------------------------------------------------------------------------------------------------------------------------------------------------------------------------------------------------------------------------------------------------------------------------------------------------------------------------------------------------------------------------------------------------------------------------------------------------------------------------------------------------------------------------------------------------------------------------------------------------------------------------------------------------------------------------------------------------------------------------------------------------------------------------------------------------------------------------------------------------------------------------------------------------------------------------------------------------------------------------------------------------------------------------------------------------------------------------------------------------------------------------------------------------------------------------------------------------------------------------------------------------------------------------------------------------------------------------------|
| <b>runExtension</b> | <b>int<br/>runExtension(int<br/>iExtensionPoint,<br/>AttributeDictionary<br/>request,<br/>AttributeDictionary<br/>response, Environ<br/>mentDictionary<br/>environment)</b> | <p>This method is called whenever a Java scripting point or service is encountered during the processing of a request.</p> <p>When runExtension is used as a script, it should process requests as quickly as possible, without blocking. This is because the server has a limited number of threads that it is using to process requests and if any one extension takes too long to run, it is likely that many requests will be delayed as each one calls the extension. runExtension must return either <b>EXT_OK</b> to indicate that processing of this request should continue or <b>EXT_ERROR</b> to indicate that an error occurred while processing this request and that the request should be dropped. Extensions should always log an error before returning <b>EXT_ERROR</b> so that the administrator has a way to determine the problem that was encountered.</p> <p>When runExtension is used as a service, it will be called once before requests start coming in (with the iExtensionPoint parameter set to <b>EXT_START_SERVICE</b>) to give the extension the opportunity to initialize resources needed to process requests, and once after the last request has been received (with the iExtensionPoint parameter set to <b>EXT_STOP_SERVICE</b>) to give the extension the opportunity to release those resources before stopping. runExtension must return one of the following values: <b>EXT_OK</b>, <b>EXT_ERROR</b> or <b>EXT_PENDING</b>. <b>EXT_PENDING</b> should be returned to inform the server that the extension has taken ownership of the request, will process the request on a background thread, and will inform the server when it is time to continue processing the request by calling reschedule() on one of the request's dictionaries.</p> |

## Interface ExtensionforSession

Classes that are going to be used as scripts at Session Manager level from Cisco Prime Access Registrar must implement the ExtensionForSession interface. When a Java scripting point or service is encountered during the processing of a request, the server will call the runExtension method defined in this interface and implemented by the appropriate class.

## Interface Extensionforsession Methods

Table A-8 lists the methods you can use for interface extensionforsession

**Table A-8** *Interface Extensionforsession Methods*

| Name                      | Syntax                                                                                                                                                                                          | Description                                                                                                                                                                                                                                                                                                                                                                                                                                                                                                                                                                                                                                                                                                                                                                                                                                                                                                                                                                                                                                                                                                                                                                                                                                                                                                                                                                                                                                                                                                                                                                                                                                                                                                                                                                                                                                                                          |
|---------------------------|-------------------------------------------------------------------------------------------------------------------------------------------------------------------------------------------------|--------------------------------------------------------------------------------------------------------------------------------------------------------------------------------------------------------------------------------------------------------------------------------------------------------------------------------------------------------------------------------------------------------------------------------------------------------------------------------------------------------------------------------------------------------------------------------------------------------------------------------------------------------------------------------------------------------------------------------------------------------------------------------------------------------------------------------------------------------------------------------------------------------------------------------------------------------------------------------------------------------------------------------------------------------------------------------------------------------------------------------------------------------------------------------------------------------------------------------------------------------------------------------------------------------------------------------------------------------------------------------------------------------------------------------------------------------------------------------------------------------------------------------------------------------------------------------------------------------------------------------------------------------------------------------------------------------------------------------------------------------------------------------------------------------------------------------------------------------------------------------------|
| <code>runExtension</code> | <code>int<br/>runExtension(int<br/>iExtensionPoint,<br/>AttributeDictionary request,<br/>AttributeDictionary response,<br/>EnvironmentDictionary environment,<br/>SessionRecord session)</code> | <p>This method is called whenever a Java scripting point or service is encountered during the processing of a request.</p> <p>When <code>runExtension</code> is used as a script, it should process requests as quickly as possible, without blocking. This is because the server has a limited number of threads that it is using to process requests and if any one extension takes too long to run, it is likely that many requests will be delayed as each one calls the extension. <code>runExtension</code> must return either <b>EXT_OK</b> to indicate that processing of this request should continue or <b>EXT_ERROR</b> to indicate that an error occurred while processing this request and that the request should be dropped. Extensions should always log an error before returning <b>EXT_ERROR</b> so that the administrator has a way to determine the problem that was encountered.</p> <p>When <code>runExtension</code> is used as a service, it will be called once before requests start coming in (with the <code>iExtensionPoint</code> parameter set to <b>EXT_START_SERVICE</b>) to give the extension the opportunity to initialize resources needed to process requests, and once after the last request has been received (with the <code>iExtensionPoint</code> parameter set to <b>EXT_STOP_SERVICE</b>) to give the extension the opportunity to release those resources before stopping. <code>runExtension</code> must return one of the following values: <b>EXT_OK</b>, <b>EXT_ERROR</b> or <b>EXT_PENDING</b>. <b>EXT_PENDING</b> should be returned to inform the server that the extension has taken ownership of the request, will process the request on a background thread, and will inform the server when it is time to continue processing the request by calling <code>reschedule()</code> on one of the request's dictionaries.</p> |

## Interface Extensionwithinitialization

Classes that are going to be used as scripts or services from Access Registrar implements the `ExtensionWithInitialization` interface. `ExtensionWithInitialization` extends the `Extension` interface with methods to initialize and destroy the extension. `initialize(java.lang.String)` is called when the extension is first loaded, with the string argument being set from the `InitializeArg` property that was defined in the server configuration when the extension was defined (either as a `Script` or a `Service`). `Destroy()` is called before the extension is unloaded.

## Interface Extensionwithinitialization Methods

Table A-9 lists the methods you can use for Interface Extensionwithinitialization.

**Table A-9** *Interface Extensionwithinitialization Methods*

| Name              | Syntax                                                 | Description                                                                     |
|-------------------|--------------------------------------------------------|---------------------------------------------------------------------------------|
| <b>initialize</b> | <b>void initialize(java.lang.String initializeArg)</b> | This method is called by the server when the extension is first loaded.         |
| <b>destroy</b>    | <b>void destroy()</b>                                  | This method is called by the server when the extension is going to be unloaded. |

## Interface ExtensionforSessionwithinitialization

Classes that are going to be used as scripts from Access Registrar at Session Manager level implement the ExtensionForSessionWithInitialization interface. ExtensionForSessionWithInitialization extends the ExtensionForSession interface with methods to initialize and destroy the extension. initialize(java.lang.String) is called when the extension is first loaded, with the string argument being set from the InitializeArg property that was defined in the server configuration when the extension was defined (either as a script or a service). Destroy () is called before the extension is unloaded.

## Interface Extensionforsessionwithinitialization Methods

Table A-10 lists the methods you can use for Interface Extensionforsessionwithinitialization.

**Table A-10** *Interface Extensionforsessionwithinitialization Methods*

| Name              | Syntax                                                 | Description                                                                     |
|-------------------|--------------------------------------------------------|---------------------------------------------------------------------------------|
| <b>initialize</b> | <b>void initialize(java.lang.String initializeArg)</b> | This method is called by the server when the extension is first loaded.         |
| <b>destroy</b>    | <b>void destroy()</b>                                  | This method is called by the server when the extension is going to be unloaded. |

## Interface MarkerExtension

This is just going to be a marker interface containing various member variables which can be used in interfaces/classes extending from this interface. Extension and ExtensionForSession interfaces will extend this interface.

## Variables in the Marker Extension Interface

Table A-11 lists the variables in the marker extension interface.

**Table A-11** Marker Extension Interface Variables

| Name                   | Syntax                                  | Description                                                                                                                                                                                                                                                                                                                                                                                      |
|------------------------|-----------------------------------------|--------------------------------------------------------------------------------------------------------------------------------------------------------------------------------------------------------------------------------------------------------------------------------------------------------------------------------------------------------------------------------------------------|
| <b>EXT_OK</b>          | <b>static final int EXT_OK</b>          | Returns <b>EXT_OK</b> by implementation of <code>runExtension()</code> to indicate that the extension operated correctly and processing of the request should continue.                                                                                                                                                                                                                          |
| <b>EXT_ERROR</b>       | <b>static final int EXT_ERROR</b>       | Returns <b>EXT_ERROR</b> by implementation of <code>runExtension()</code> to indicate that the extension failed in some way and processing of the request should NOT continue.                                                                                                                                                                                                                   |
| <b>EXT_PENDING</b>     | <b>static final int EXT_PENDING</b>     | Returns <b>EXT_PENDING</b> by implementations of <code>runExtension()</code> to indicate that the extension operated correctly and the extension wants to take ownership of the request for a while. Further processing of the request by the server will be postponed until the extension indicates that it can do so by calling the <code>reschedule</code> method on any of the dictionaries. |
| <b>EXT_LOG_ERROR</b>   | <b>static final int EXT_LOG_ERROR</b>   | Indicates that the message should be logged with a severity of <b>ERROR</b> , when passed to <code>log()</code> in the level parameter.                                                                                                                                                                                                                                                          |
| <b>EXT_LOG_WARNING</b> | <b>static final int EXT_LOG_WARNING</b> | Indicates that the message should be logged with a severity of <b>WARNING</b> , when passed to <code>log()</code> in the level parameter.                                                                                                                                                                                                                                                        |
| <b>EXT_LOG_INFO</b>    | <b>static final int EXT_LOG_INFO</b>    | Indicates that the message should be logged with a severity of <b>INFO</b> , when passed to <code>log()</code> in the level parameter.                                                                                                                                                                                                                                                           |
| <b>EXT_REMOVE_ALL</b>  | <b>static final int EXT_REMOVE_ALL</b>  | Indicates that all values associated with the specified key should be removed, when passed to <code>AttributeDictionary::remove()</code> in the index parameter.                                                                                                                                                                                                                                 |
| <b>EXT_REPLACE</b>     | <b>static final int EXT_REPLACE</b>     | Indicates that all existing values associated with the specified key(s) should be removed before adding the new value(s), when passed to <code>AttributeDictionary::put()</code> (and its variants) in the index parameter or to <code>AttributeDictionary::addProfile()</code> in the mode parameter.                                                                                           |
| <b>EXT_APPEND</b>      | <b>static final int EXT_APPEND</b>      | Indicates that the new value(s) should be appended to the end of the list of any existing values associated with the specified key(s), when passed to <code>AttributeDictionary::put()</code> (and its variants) in the index parameter or to <code>AttributeDictionary::addProfile()</code> in the mode parameter.                                                                              |

Table A-11 Marker Extension Interface Variables (continued)

| Name                                                | Syntax                                                                   | Description                                                                                                                                                                                                                                                                                                                                                                         |
|-----------------------------------------------------|--------------------------------------------------------------------------|-------------------------------------------------------------------------------------------------------------------------------------------------------------------------------------------------------------------------------------------------------------------------------------------------------------------------------------------------------------------------------------|
| <b>EXT_AUGMENT</b>                                  | <b>static final int<br/>EXT_AUGMENT</b>                                  | Indicates that the new association(s) should only be added if the dictionary does not already have an entry for the given key(s), when passed to <code>AttributeDictionary::put()</code> (and its variants) in the index parameter or to <code>AttributeDictionary::addProfile()</code> in the mode parameter.                                                                      |
| <b>EXT_START_SERVICE</b>                            | <b>static final int<br/>EXT_START_SERVICE</b>                            | Indicates that the extension should do whatever is necessary to prepare to offer service, when passed to extensions used as services. This may include starting background threads, opening database connections, and so on.                                                                                                                                                        |
| <b>EXT_AUTHENTICATION_SERVICE</b>                   | <b>static final int<br/>EXT_AUTHENTICATION_SERVICE</b>                   | Indicates that the extension should authenticate the current request, when passed to extensions used as services. To indicate whether the request was authenticated or not, the extension should set the <code>EnvironmentDictionary</code> entry for "Response-Type" to either "Access-Accept" or "Access-Reject".                                                                 |
| <b>EXT_AUTHORIZATION_SERVICE</b>                    | <b>static final int<br/>EXT_AUTHORIZATION_SERVICE</b>                    | Indicates that the extension should authorize the current request, when passed to extensions used as services.                                                                                                                                                                                                                                                                      |
| <b>EXT_AUTHENTICATION_AND_AUTHORIZATION_SERVICE</b> | <b>static final int<br/>EXT_AUTHENTICATION_AND_AUTHORIZATION_SERVICE</b> | Indicates that the extension should both authenticate and authorize the current request, when passed to extensions used as services. To indicate whether the request was authenticated or not, the extension should set the <code>EnvironmentDictionary</code> entry for "Response-Type" to either "Access-Accept" or "Access-Reject".                                              |
| <b>EXT_ACCOUNTING_SERVICE</b>                       | <b>static final int<br/>EXT_ACCOUNTING_SERVICE</b>                       | Indicates that the extension should produce an accounting record for the current request, when passed to extensions used as services.                                                                                                                                                                                                                                               |
| <b>EXT_STOP_SERVICE</b>                             | <b>static final int<br/>EXT_STOP_SERVICE</b>                             | Indicates that the extension should do whatever is necessary to shut down, when passed to extensions used as services. This may include stopping background threads, closing database connections and so on.                                                                                                                                                                        |
| <b>EXT_NAS_STARTED_ACCOUNTING_SERVICE</b>           | <b>static final int<br/>EXT_NAS_STARTED_ACCOUNTING_SERVICE</b>           | Indicates that the NAS identified in the <code>EnvironmentDictionary</code> (by either the "NAS-Identifier" or "NAS-IP-Address" entries) has indicated that it is starting up, when passed to extensions used as services. This may be used by extensions to prepare to receive requests from this particular NAS if the extension treats requests from different NASs differently. |

Table A-11 Marker Extension Interface Variables (continued)

| Name                                          | Syntax                                                            | Description                                                                                                                                                                                                                                                                                                                                                        |
|-----------------------------------------------|-------------------------------------------------------------------|--------------------------------------------------------------------------------------------------------------------------------------------------------------------------------------------------------------------------------------------------------------------------------------------------------------------------------------------------------------------|
| EXT_NAS_STOPPED_ACCOUNTING_SERVICE            | static final int<br>EXT_NAS_STOPPED_ACCOUNTING_SERVICE            | Indicates that the NAS identified in the EnvironmentDictionary (by either the "NAS-Identifier" or "NAS-IP-Address" entries) has indicated that it is shutting down, when passed to extensions used as services. This may be used by extensions to recover any resources associated with this NAS if the extension treats requests from different NASs differently. |
| EXT_INCOMING_SERVER_SCRIPTING_POINT           | static final int<br>EXT_INCOMING_SERVER_SCRIPTING_POINT           | Indicates that the extension is being called from the script <b>/Radius/IncomingScript</b> , when passed to extensions used as scripts.                                                                                                                                                                                                                            |
| EXT_INCOMING_VENDOR_SCRIPTING_POINT           | static final int<br>EXT_INCOMING_VENDOR_SCRIPTING_POINT           | Indicates that the extension is being called from the script <b>/Radius/Vendors/&lt;vendor&gt;/IncomingScript</b> , when passed to extensions used as scripts.                                                                                                                                                                                                     |
| EXT_INCOMING_CLIENT_SCRIPTING_POINT           | static final int<br>EXT_INCOMING_CLIENT_SCRIPTING_POINT           | Indicates that the extension is being called from the script <b>/Radius/Clients/&lt;client&gt;/IncomingScript</b> or from the script <b>/Radius/RemoteServers/&lt;server&gt;/IncomingScript</b> , when passed to extensions used as scripts.                                                                                                                       |
| EXT_INCOMING_SERVICE_SCRIPTING_POINT          | static final int<br>EXT_INCOMING_SERVICE_SCRIPTING_POINT          | Indicates that the extension is being called from the script <b>/Radius/Services/&lt;service&gt;/IncomingScript</b> , when passed to extensions used as scripts.                                                                                                                                                                                                   |
| EXT_USERGROUP_AUTHENTICATION_SCRIPTING_POINT  | static final int<br>EXT_USERGROUP_AUTHENTICATION_SCRIPTING_POINT  | Indicates that the extension is being called from the script <b>/Radius/UserGroups/&lt;group&gt;/AuthenticationScript</b> , when passed to extensions used as scripts.                                                                                                                                                                                             |
| EXT_USERRECORD_AUTHENTICATION_SCRIPTING_POINT | static final int<br>EXT_USERRECORD_AUTHENTICATION_SCRIPTING_POINT | Indicates that the extension is being called from the script <b>/Radius/UserLists/&lt;userlist&gt;/&lt;user&gt;/AuthenticationScript</b> , when passed to extensions used as scripts.                                                                                                                                                                              |
| EXT_USERGROUP_AUTHORIZATION_SCRIPTING_POINT   | static final int<br>EXT_USERGROUP_AUTHORIZATION_SCRIPTING_POINT   | Indicates that the extension is being called from the script <b>/Radius/UserGroups/&lt;group&gt;/AuthorizationScript</b> , when passed to extensions used as scripts.                                                                                                                                                                                              |
| EXT_USERRECORD_AUTHORIZATION_SCRIPTING_POINT  | static final int<br>EXT_USERRECORD_AUTHORIZATION_SCRIPTING_POINT  | Indicates that the extension is being called from the script <b>/Radius/UserLists/&lt;userlist&gt;/&lt;user&gt;/AuthorizationScript</b> , when passed to extensions used as scripts.                                                                                                                                                                               |
| EXT_OUTGOING_SERVICE_SCRIPTING_POINT          | static final int<br>EXT_OUTGOING_SERVICE_SCRIPTING_POINT          | Indicates that the extension is being called from the script <b>/Radius/Services/&lt;service&gt;/OutgoingScript</b> , when passed to extensions used as scripts.                                                                                                                                                                                                   |

Table A-11 Marker Extension Interface Variables (continued)

| Name                                        | Syntax                                                          | Description                                                                                                                                                                                                                                  |
|---------------------------------------------|-----------------------------------------------------------------|----------------------------------------------------------------------------------------------------------------------------------------------------------------------------------------------------------------------------------------------|
| EXT_OUTGOING_CLIENT_SCRIPTING_POINT         | static final int<br>EXT_OUTGOING_CLIENT_SCRIPTING_POINT         | Indicates that the extension is being called from the script <b>/Radius/Clients/&lt;client&gt;/OutgoingScript</b> or from the script <b>/Radius/RemoteServers/&lt;server&gt;/OutgoingScript</b> , when passed to extensions used as scripts. |
| EXT_OUTGOING_VENDOR_SCRIPTING_POINT         | static final int<br>EXT_OUTGOING_VENDOR_SCRIPTING_POINT         | Indicates that the extension is being called from the script <b>/Radius/Vendors/&lt;vendor&gt;/OutgoingScript</b> , when passed to extensions used as scripts.                                                                               |
| EXT_OUTGOING_SERVER_SCRIPTING_POINT         | static final int<br>EXT_OUTGOING_SERVER_SCRIPTING_POINT         | Indicates that the extension is being called from the script <b>/Radius/OutgoingScript</b> , when passed to extensions used as scripts.                                                                                                      |
| EXT_REMOTE_SERVER_OUTAGE_SCRIPTING_POINT    | static final int<br>EXT_REMOTE_SERVER_OUTAGE_SCRIPTING_POINT    | Indicates that the extension is being called from the script <b>/Radius/Services/&lt;service&gt;/OutageScript</b> , when passed to extensions used as scripts.                                                                               |
| EXT_INCOMING_SESSIONMANAGER_SCRIPTING_POINT | static final int<br>EXT_INCOMING_SESSIONMANAGER_SCRIPTING_POINT | Indicates that the extension is being called from the script <b>/Radius/SessionManagers/&lt;sessionmgr&gt;/IncomingScript</b> , when passed to extensions used as scripts.                                                                   |
| EXT_OUTGOING_SESSIONMANAGER_SCRIPTING_POINT | static final int<br>EXT_OUTGOING_SESSIONMANAGER_SCRIPTING_POINT | Indicates that the extension is being called from the script <b>/Radius/SessionManagers/&lt;sessionmgr&gt;/OutgoingScript</b> , when passed to extensions used as scripts.                                                                   |

## Class Sessionrecord

Each request processed by an Extension will have a corresponding session. The methods present in this class operate on the attributes cached in that session record. Group of attributes are cached as an AttributeDictionary in the session record.

## Session Record Methods

Table A-12 lists the methods you can use for Session record.

Table A-12 Session Record Methods

| Name | Syntax                                                         | Description                                              |
|------|----------------------------------------------------------------|----------------------------------------------------------|
| get  | public java.lang.String<br>get(java.lang.String key)           | Returns the first value associated with key.             |
| get  | public java.lang.String<br>get(java.lang.String key,int index) | Returns the value at position index associated with key. |



Table A-12 Session Record Methods (continued)

| Name           | Syntax                                                                                        | Description                                                                                                                                                                                                                                                                                                                                                                                                                                                                                                                                                                                                                                                                                                                                                                                                                                                     |
|----------------|-----------------------------------------------------------------------------------------------|-----------------------------------------------------------------------------------------------------------------------------------------------------------------------------------------------------------------------------------------------------------------------------------------------------------------------------------------------------------------------------------------------------------------------------------------------------------------------------------------------------------------------------------------------------------------------------------------------------------------------------------------------------------------------------------------------------------------------------------------------------------------------------------------------------------------------------------------------------------------|
| put            | <b>public boolean<br/>put(java.lang.String<br/>key,java.lang.String<br/>value)</b>            | Associates key with value and stores it to the session record. Any existing values associated with key are removed before adding this association.<br><br>The value can be retrieved by calling the get method with a key that is equal to the original key.                                                                                                                                                                                                                                                                                                                                                                                                                                                                                                                                                                                                    |
| put            | <b>public boolean<br/>put(java.lang.String<br/>key,java.lang.String<br/>value, int index)</b> | Associates key with value depending on the value of index and stores it in the session record. If index equals <b>ExtensionForSession.EXT_REPLACE</b> , any existing values are removed before adding this new association. If index equals <b>ExtensionForSession.EXT_APPEND</b> , the new value is added at the end of the list of existing values. If index equals <b>ExtensionForSession.EXT_AUGMENT</b> , the new association is only made if the session record does not already have an entry for key. If index is a number greater than or equal to 0 and less than the number of entries in the list, the value is inserted at that position in the list. Otherwise, the value is appended at the end of the list.<br><br>The value can be retrieved by calling the get method with a key that is equal to the original key and the appropriate index. |
| remove         | <b>public boolean<br/>remove(java.lang.String<br/>key)</b>                                    | Removes key (and all corresponding values) from the session record. This method does nothing if key is not in the session record.                                                                                                                                                                                                                                                                                                                                                                                                                                                                                                                                                                                                                                                                                                                               |
| remove         | <b>public boolean<br/>remove(java.lang.String<br/>key, int index)</b>                         | Removes value at the position index that is associated with key. If the index equals <b>ExtensionForSession.EXT_REMOVE_ALL</b> or if the value being removed is the last value associated with key, the key is removed from the session record. This method does nothing if key is not in the session record.                                                                                                                                                                                                                                                                                                                                                                                                                                                                                                                                                   |
| getSessionInfo | <b>public java.lang.String<br/>getSessionInfo()</b>                                           | Returns Session-ID, Session-Start-Time and Session-Last-Accessed-Time of the session record.                                                                                                                                                                                                                                                                                                                                                                                                                                                                                                                                                                                                                                                                                                                                                                    |

**Note**

A sample java script is available in the following path “/cisco-ar/examples/java” after the installation of AR.





## APPENDIX **B**

# Environment Dictionary

---

This appendix describes the environment variables the scripts use to communicate with Cisco Prime Access Registrar (Cisco Prime AR) or to communicate with other scripts.

Cisco Prime AR sets the **arguments** variable in the Environment dictionary, before calling the **InitEntryPoint** of each script. The **arguments** variable is set to the value of the **InitEntryPointArgs** property corresponding to that script, and it allows the administrator to pass (possibly unique) information to each script initialization function.

Environment variables that are set and read for resource management override provide scripts further control over session management. These environment variables, including the following **Acquire-User-Session-Limit**, **Acquire-Group-Session-Limit**, **Acquire-IP-Dynamic**, **Acquire-IP-Per-NAS-Port**, **Acquire-IPX-Dynamic**, and **Acquire-USR-VPN**, can be set at any point before session management is invoked. These environment variables are read as the packet flows through each Resource Manager that the chosen Session Manager calls. The default setting for these environment variables is TRUE. See the “[Resource Managers](#)” section on page 4-37 for additional information about Resource Managers.

This appendix has the following major sections:

- [Cisco Prime Access Registrar Environment Dictionary Variables](#)

This section lists environment variables you can use in scripts to communicate with Cisco Prime AR or to communicate with other scripts.

- [Internal Variables](#)

This section lists environment variables used by the Cisco Prime AR server for internal operations. The environment variables listed in this section must not be modified by scripts.

## Cisco Prime Access Registrar Environment Dictionary Variables

The following variables are text strings stored in the Environment dictionary passed to each scripting point.

### Accepted-Profiles

**Accepted-Profiles** is read during authorization after calling server and client incoming scripts (not set by Cisco Prime AR code). If set, the authorization done by local user lists checks to see if the given user's profile as specified in the user record is one of those in the separated list of profiles. If it is not in the separated list of profiles, the request is rejected.

## Accounting-Service

**Accounting-Service** is set after calling server and client incoming scripts and is used to determine which accounting service is used for this request. If set, the server directs the request to be processed by the specified accounting service.

When **Accounting-Service** is not set, the **DefaultAccountingService** (as defined in the server configuration) is used instead.

## Acquire-Dynamic-DNS

**Acquire-Dynamic-DNS** is set and read for resource management override. **Acquire-Dynamic-DNS** is set to FALSE to skip DNS updating during resource management processing.

## Acquire-Group-Session-Limit

**Acquire-Group-Session-Limit** is set and read for resource management override.

**Acquire-Group-Session-Limit** is set to FALSE to override the use of group session limit resource management.

## Acquire-Home-Agent

**Acquire-Home-Agent** is set and read for resource management override. **Acquire-Home-Agent** is set to FALSE to override the allocation of the home agent IP address during resource management processing.

## Acquire-IP-Dynamic

**Acquire-IP-Dynamic** is set and read for resource management override. **Acquire-IP-Dynamic** is set to FALSE to override the use of a managed pool of IP addresses resource management.

## Acquire-IPX-Dynamic

**Acquire-IPX-Dynamic** is set and read for resource management override. **Acquire-IPX-Dynamic** is set to FALSE to override the use of a managed pool of IPX addresses resource management.

## Acquire-IP-Per-NAS-Port

**Acquire-IP-Per-NAS-Port** is set and read for resource management override.

**Acquire-IP-Per-NAS-Port** is set to FALSE to override the use of ports associated with specific IP addresses resource management.

## Acquire-Subnet-Dynamic

**Acquire-Subnet-Dynamic** is not always used. If set to FALSE, subnet-dynamic resource managers are skipped.

## Acquire-User-Session-Limit

**Acquire-User-Session-Limit** set and read for resource management override.

**Acquire-User-Session-Limit** is set to FALSE to override the use of user session limit resource management.

## Acquire-USR-VPN

**Acquire-USR-VPN** is set and read for resource management override. **Acquire-USR-VPN** is set to FALSE to override the use of Virtual Private Networks (VPNs) that use USR NAS Clients resource management.

## Allow-Null-Password

**Allow-Null-Password** is read during password matching and set in local userlist password matching if not set prior. If **Allow-Null-Password** is set to TRUE, the Cisco Prime AR server accepts requests with null passwords.

## Authentication-Service

**Authentication-Service** is set and read for authentication service selection and is used to determine which service is used to authenticate the user. If set, the server directs the request to be processed by the specified authentication service. When **Authentication-Service** is not set, the **DefaultAuthenticationService** is used instead.

## Authorization-Service

**Authorization-Service** is set and read for authorization service selection and is used to determine which service to use to authorize the user. If set, the server directs the request to be processed by the specified authorization service. When **Authorization-Service** is not set, the **DefaultAuthorizationService** is used instead.

## AuthorizationInfo

The MSISDN information is copied to **AuthorizationInfo** that is fetched by M3UA service.

## BackingStore-Env-Vars

**BackingStore-Env-Vars** overrides the `BackingStoreEnvironmentVariables` property of remote servers of type *odbc-accounting* only when the property `BufferAccountingPackets` is set to `TRUE`. The value is a comma separated list of environment variables to be stored along with the packet contents in the local disk.

## Broadcast-Accounting-Packet

If set to `TRUE`, **Broadcast-Accounting-Packet** enables broadcasting of Accounting-on or Accounting-off packets to all remote servers of type *radius*.

## Cache-Attributes-In-Session

**Cache-Attributes-In-Session** is set and read for resource management override. **Cache-Attributes-In-Session** is set to `FALSE` to override the caching of attributes by the *session-cache* type of resource manager.

## Current-Group-Count

**Current-Group-Count** is set and read for group session management. If set, the group-session-limit resource manager sets **Current-Group-Count** to be the new value of the group-session-limit counter.

## Cache-Outer-Identity

**Cache-Outer-Identity value** is set to enable identifying session of an user. If it is set to `TRUE`, WiMAX session manager will cache the outer identity. If it is set to `FALSE`, the WiMAX session manager will cache the inner identity. The value is set to `FALSE` by default.

## Destination-IP-Address

**Destination-IP-Address** is a read only value which is set to the receiver IP address.  
**Destination-IP-Address** contains the IP address of the request packet receiver.

## Destination-Port

**Destination-port** is a read only value which is set to the receiving port number. **Destination-port** contains the port number of the receiver of the request.

## Dest-Translation-Type

**Dest-Translation-Type** is configured through the GlobalTitleTranslationScript. When the RoutingIndicator is set to **RTE\_GT**, Cisco Prime AR server reads the value that is set in Dest-Translation-Type and sets the TranslationType field of the Called Party Address. The value in this environment variable overrides the value that is configured in the DestinationGTAddress/DestTranslationType property of a remote server, SIGTRAN-M3UA.

## Dest-Numbering-Plan

**Dest-Numbering-Plan** is configured through the GlobalTitleTranslationScript. When the RoutingIndicator is set to **RTE\_GT**, Cisco Prime AR server reads the value that is set in Dest-Numbering-Plan and sets the NumberingPlan field of the Called Party Address. The value in this environment variable overrides the value that is configured in the DestinationGTAddress/Dest-Numbering-Plan property of a remote server, SIGTRAN-M3UA.

The following are the only values that are used for Dest-Numbering-Plan environment variable:

- DATA
- GENERIC
- ISDN
- ISDNMOB
- LANMOB
- MARMOB
- NWSPEC
- TEL
- TELEX
- UNKN

If you set any variable other than the above ones, Cisco Prime AR server sets the NumberingPlan that is configured in DestinationGTAddress/Dest-Numbering-Plan property of a remote server of type SIGTRAN-M3UA.

## Dest-Encoding-Scheme

**Dest-Encoding-Scheme** is configured through the GlobalTitleTranslationScript. When the RoutingIndicator is set to **RTE\_GT**, Cisco Prime AR server reads the value that is set in Dest-Encoding-Scheme environment variable and sets the EncodingScheme field of the Called Party Address. The value in this environment variable overrides the value that is configured in the DestinationGTAddress/ DestEncodingScheme property of a remote server, SIGTRAN-M3UA.

The following are the only values that are used for Dest-Encoding-Scheme environment variable:

- BCDEVEN
- BCDODD

If you set any variable other than the above ones, Cisco Prime AR server sets the EncodingScheme that is configured in the DestinationGTAddress/ DestEncodingScheme property of a remote server of type SIGTRAN-M3UA.

## Dest-Nature-Of-Address

**Dest-Nature-Of-Address** is configured through the GlobalTitleTranslationScript. When the RoutingIndicator is set to **RTE\_GT**, Cisco Prime AR server reads the value that is set in Dest-Nature-Of-Address environment variable and sets the NatureOfAddress field of the Called Party Address. The value in this environment variable overrides the value that is configured in the DestinationGTAddress/ DestNatureofAddress property of a remote server, SIGTRAN-M3UA.

The following are the only values that are used for Dest-Nature-Of-Address environment variable:

- ADDR\_NOTPRSNT
- INTNUM
- NATSIGNUM
- SUBNUM

If you set any variable other than the above ones, Cisco Prime AR server sets the NatureOfAddress that is configured in the DestinationGTAddress/ DestNatureofAddress property of a remote server of type SIGTRAN-M3UA.

## Dest-GT-Format

**Dest-GT-Format** configured through the GlobalTitleTranslationScript. When the RoutingIndicator is set to **RTE\_GT**, Cisco Prime AR server reads the value that is set in Dest-GT-Format environment variable and uses this format specified for the Global Title Digits(Address Information). The value in this environment variable overrides the value that is configured in the DestinationGTAddress/ DestGTFormat property of a remote server, SIGTRAN-M3UA.

The following are the only values that are used for Dest-GT-Format environment variable:

- GTFRMT\_0
- GTFRMT\_1
- GTFRMT\_2
- GTFRMT\_3
- GTFRMT\_4
- GTFRMT\_5

If you set any variable other than the above ones, Cisco Prime AR server sets the GTFormat that is configured in the DestinationGTAddress/ DestGTFormat property of a remote server of type SIGTRAN-M3UA.

## Disable-Accounting-On-Off-Broadcast

If set to TRUE, **Disable-Accounting-On-Off-Broadcast** disables broadcasting of Accounting-On and Accounting-Off packets to all remote servers of type 'radius'.



## DSA-Response-Cache

DSA-Response-Cache is used while performing DSA( Dynamic Service Authorization) feature in Cisco Prime AR. It is FALSE by default, which will clear the response dictionary before Re-Authentication. If DSA-Response-Cache is set to TRUE, Cisco Prime AR will not clear the response dictionary before Re-Authenticating with next service configured.

## Dynamic-DNS-HostName

**Dynamic-DNS-HostName** is read while constructing the forward hostname during resource management processing to update DNS entries. If set, the name will be used as forward hostname instead of constructing one.

## Dynamic-Search-Filter

**Dynamic-Search-Filter** overrides the Filter property in remote servers of type *ldap*. The format of the value set for **Dynamic-Search-Filter** should be similar to that of the Filter property.

## Dynamic-Search-Path

**Dynamic-Search-Path** is read for LDAP searching. If set, the server uses it as its LDAP search path rather than the value set in the remote server configuration.

## Dynamic-Search-Scope

**Dynamic-Search-Scope** is used to dynamically set the SearchScope property of an LDAP remote server configuration on a per-packet basis.

## Dynamic-Service-Loop-Limit

**Dynamic-Service-Loop-Limit** variable is used to change loop counts. When using the same service for reauthentication and reauthorization, a loop can occur in these services. The loop count, by default is 10. You can change the loop count using this variable.

## Dynamic-User-Password-Attribute

**Dynamic-User-Password-Attribute** is read for LDAP authentication and overrides the UserPasswordAttribute. If set, the server uses it to retrieve the password field as its LDAP UserPassword attribute instead of the value set in the remote server configuration.

## EAP-Actual-Identity

**EAP-Actual-Identity** is a read-only variable that contains the International Mobile Subscriber Identity (IMSI) of the user after a successful EAP-SIM authentication.

## EAP-Authentication-Mode

**EAP-Authentication-Mode** is a read-only variable, set after a successful EAP-SIM authentication, that indicates whether the EAP-SIM authentication was a reauthentication or a full authentication.

## Enforce-Traffic-Throttling

By default, the value is set to FALSE. When set to TRUE, the traffic throttling check for the packet will be executed.

## Generate-BEK

Generate-BEK is read when WiMax provisioning service is enabled. If this is set, Cisco Prime AR will generate the Bootstrap Encryption Key in the WiMax flow.

## Group-Session-Limit

**Group-Session-Limit** is set and read for group session management. The group-session-limit resource manager sets this environment variable to be the limit of the group-session-limit counter as set by the configuration.

## HLR-GlobalTitle-Address

**HLR-GlobalTitle-Address** is configured through the GlobalTitleTranslationScript. When the RoutingIndicator is set to **RTE\_GT** in SIGTRAN-M3UA remote server, Cisco Prime AR server reads the value that is set in HLR-GlobalTitle-Address and sets the Destination GT Digits(Address Information field) of the Called Party Address.

## HLR-Translated-IMSI

**HLR-Translated-IMSI** is configured through the IMSITranslationScript. Cisco Prime AR server reads the value in HLR-Translated-IMSI and sets the value as IMSI before sending the request to STP/HLR. The value that is configured in the HLR-Translated-IMSI environment variable overrides the IMSI received in EAP-AKA/EAP-SIM request packet.

## Ignore-Accounting-Signature

**Ignore-Accounting-Signature** is set after calling server and client incoming scripts and is used to ignore missing or incorrect accounting signatures from NASs. If set, Cisco Prime AR does not check whether the account request packet has been signed with the same shared secret as the NAS.

**Ignore-Accounting-Signature** is used to work with RADIUS implementations that did not sign Accounting-Requests. A script was provided in the distribution (for USR NASs) that could be set in the IncomingScript extension point for the USR Vendor that simply set this environment variable.

## Incoming-Translation-Groups

**Incoming-Translation-Groups** is read for authentication while processing responses from a remote RADIUS server. If set, **Incoming-Translation-Groups** specifies the translation groups to be used to filter attributes on requests.

## Master-URL-Fragment

Used with the Windows Provisioning Service feature, **Master-URL-Fragment** specifies the fragment within the Master URL to be sent back to the provisioning server. **Master-URL-Fragment** can be set to any of the following four values: *signup*, *renewal*, *passwordchange*, and *forceupdate*. If **Master-URL-Fragment** is not set and is required to send the URL, *signup* will be sent by default.

The environmental variable **Send-PEAP-URL-TLV** indicates whether or not to send the URL.

## Misc-Log-Message-Info

**Misc-Log-Message-Info** is read for packet event logging. If a log message is generated, the value of **Misc-Log-Message-Info** is inserted into the middle of the log message.

## Outgoing-Translation-Groups

**Outgoing-Translation-Groups** is read while proxying to a remote radius server. If set, **Outgoing-Translation-Groups** specifies the translation groups to be used to filter attributes.

## Pager

The **aregcmd** command supports the **Pager** environment variable. When the **aregcmd** command **stats** is used and the **Pager** environment variable is set, the output of the **stats** command is displayed using the program specified by the **Pager** environment variable.

## Query-Service

The Query-Service variable is set and read for the *radius-query* service selection type. The Query-Service variable must be set before authentication phase begins at the server, vendor, or client incoming scripting point or using the policy engine. If set, the server directs requests to be processed by the specified *radius-query* service. After the Query-Service variable is set, no AAA processing will be done.

## Re-Accounting-Service

**Re-Accounting-Service** is configured, through script, for dynamic service authorization. When the Re-Accounting-Service is set, the server directs the request to the specified reaccounting service for processing.

## Re-Authentication-Service

**Re-Authentication-Service** is configured, through script, for dynamic service authorization. When the Re-Authentication-Service is set, the server directs the request to the specified reauthentication service for processing.

## Re-Authorization-Service

**Re-Authorization-Service** is configured, through script, for dynamic service authorization. When the Re-Authorization-Service is set, the server directs the request to the specified reauthorization service for processing.

## Realm

The **Realm** variable is set for *domain-auth* type of service and is used as the domain name for windows authentication.

## Reject-Reason

**Reject-Reason** is set when a request is being rejected and contains the **Reject-Reason**. Cisco Prime AR uses the value of **Reject-Reason** to look up the reject reason in the reply message table.

If **Reject-Reason** is set to one of: UnknownUser, UserNotEnabled, UserPasswordInvalid, UnableToAcquireResource, ServiceUnavailable, InternalError, MalformedRequest, ConfigurationError, IncomingScriptFailed, OutgoingScriptFailed, IncomingScriptRejectedRequest, OutgoingScriptRejectedRequest, or TerminationAction, then the value set in the configuration under **/Radius/Advanced/ReplyMessages** will be returned.

## Remote-Server

**Remote-Server** is set and read for logging a rejected packet from a remote server. **Remote-Server** records the name and IP address of the remote server to which the request has been forwarded.

## Remove-Session-On-Acct-Stop

When set to TRUE, server removes the session on receiving an accounting stop packet.

## Remote-Servers-Tried

**Remote-Servers-Tried** contains a list of remote servers that were tried before a request was accepted or rejected (in the case of a Failover multiple remoteserver policy). The list of servers is a comma-separated list of remote server names.

## Request-Authenticator

**Request-Authenticator** is set for every packet upon reception. Getting the **Request-Authenticator** from a script returns the value of the request authenticator.

## Request-Type

**Request-Type** is set when a request is first received to the type of request, such as one of Access-Request, Access-Accept, Access-Reject, Accounting-Request, Accounting-Response, or Access-Challenge before calling any extension points.

The request contains a string representation of the RADIUS packet type (code). When Cisco Prime AR does not recognize the packet type, it is represented as “Unknown-Packet-Type-*<N>*”, where *<N>* is the numeric value of the packet type (for example “Unknown-Packet-Type-9”). The known packet types are listed in [Table B-1](#).

**Table B-1** Request-Type Packets

| String                      | Packet Code |
|-----------------------------|-------------|
| Access-Request              | (1)         |
| Access-Accept               | (2)         |
| Access-Reject               | (3)         |
| Accounting-Request          | (4)         |
| Accounting-Response         | (5)         |
| Access-Challenge            | (11)        |
| Status-Server               | (12)        |
| Status-Client               | (13)        |
| USR-Resource-Free-Request   | (21)        |
| USR-Resource-Free-Response  | (22)        |
| USR-Resource-Query-Request  | (12)        |
| USR-Resource-Query-Response | (24)        |
| USR-NAS-Reboot-Request      | (26)        |
| USR-NAS-Reboot-Response     | (27)        |
| Ascend-IPA-Allocate         | (50)        |
| Ascend-IPA-Release          | (51)        |
| USR-Enhanced-Radius         | (254)       |



**Note**

**Request-Type** is to be used as a read-only variable by scripts.

## Require-User-To-Be-In-Authorization-List

**Require-User-To-Be-In-Authorization-List** is read for authorization. If we are authorizing with a different service than we authenticated with (not usually done) and the user is not known by the authorization service, the default is to continue on unless this environment variable is set, in which case we reject the request with a cause of Unknown-user.

## Response-Type

**Response-Type** is set and read throughout processing and used to determine whether the request should be accepted, rejected, or challenged. When **Response-Type** is set to "Access-Reject at any time during the processing of a request, no more processing of the request is done, and an Access-Reject response is sent. For other valid values for **Response-Type**, see [Table B-1](#).

## Retrace-Packet

If set, **Retrace-Packet**, causes a trace the packet to be displayed during the incoming and outgoing scripts. If set, will cause a second trace of the request packet's contents after running all the incoming scripts and/or a second trace of the response packet's contents before running the outgoing scripts.

## Send-PEAP-URI-TLV

When set to TRUE, the URI PEAP-TLV is included along with the Result PEAP-TLV in the access-challenge packet. The authenticating user service (of type userlist, LDAP, or WDA) can set this to TRUE using an extension point script or attribute mapping so that the PEAP-v0 service can send the URI PEAP-TLV. The default value for this is FALSE.

**Note**

---

This variable is used with the Windows Provisioning Service (WPS) feature.

---

## Session-Key

**Session-Key** is read for session management. If set, the server uses it as the key to look up the session associated with the current request, if any. If not set, the server uses the NAS IP Address and NAS Port to create a session key.

## Session-Manager

**Session-Manager** is read after user authorization and determines which dynamic resources to allocate for this user, when one is needed. If set, the server directs the request to be processed by the specified session manager. When not set, the SessionManager (as defined in **DefaultSessionManager**) is used when needed.

## Session-Notes

**Session-Notes** is a comma-separated list set to make session information available to scripts. **Session-Notes** contains the names of other environment variables. If set, these variables are stored on a Session as notes.

## Session-Service

**Session-Service** is set and read during session management. If set, the server will direct the request to be processed by the specified session service.

## Set-Session-Mgr-And-Key-Upon-Lookup

When **Set-Session-Mgr-And-Key-Upon-Lookup** is set to TRUE, a session-cache resource manager sets the session-manager and session-key environment variable during a query-lookup, and the Cisco Prime AR server does not cache the response dictionary attributes.

**Set-Session-Mgr-And-Key-Upon-Lookup** is set to TRUE by a query-service IncomingScript.

## Skip-Session-Management

When set to TRUE in a request, **Skip-Session-Management** causes session management to be skipped for the request, even if session management might normally occur.

## Skip-Overriding-Username-With-LDAP-UID

**Skip-Overriding-Username-With-LDAP-UID** is used to decide if the username should be replaced with the UID from the LDAP server. When **Skip-Overriding-Username-With-LDAP-UID** is set to TRUE, the username is not replaced with the UID from the LDAP server.

You can use **Skip-Overriding-Username-With-LDAP-UID** to retain case sensitivity in usernames when the username given logging in to the network is in a different case than the UID in the LDAP server database, such as *User1* and *user1*.

## Skip-Overriding-UserName-With-PEAPIdentity

**Skip-Overriding-Username-With-PEAPIdentity** is used to decide if the username should be replaced with the PEAP Identity. When **Skip-Overriding-Username-With-PEAPIdentity** is set to TRUE, the username is not replaced with the PEAP Identity.

## Source-IP-Address

**Source-IP-Address** is set when a request is first received to the IP address from which the IP request was received before calling any extension points. **Source-IP-Address** contains the IP address of the NAS or proxy server that sent the request to this server.

**Note**

---

**Source-IP-Address** is to be used as a read-only variable by scripts.

---



## Source-Port

**Source-Port** is set when a request is first received to the port from which the request was received. Source-Port is set for each request before calling any extension points and contains the port on the NAS or proxy server that was used to send the request to this server.



Note

---

**Source-Port** is to be used as a read-only variable by scripts.

---

## Subnet-Size-If-No-Match

**Subnet-Size-If-No-Match** is set to one of BIGGER, SMALLER or EXACT, determines the behavior of the subnet-dynamic resource manager if a pool of the requested size is not available.

## Trace-Level

**Trace-Level** is set for each request before calling any extension points. **Trace-Level** is set to the current trace level as specified through **aregcmd**. If set by a script, Trace-Level changes the trace level used to determine what level of information is traced.

## Unavailable-Resource

**Unavailable-Resource** is set during session management. If the request is being rejected because one of the resource managers failed to allocate a resource, **Unavailable-Resource** is set to the name of the resource manager that failed.

## Unavailable-Resource-Type

**Unavailable-Resource-Type** is set during session management. If the request is being rejected because one of the resource managers failed to allocate a resource, **Unavailable-Resource-Type** is set to the type of the resource manager that failed.

## UserDefined1

**UserDefined1** is set to the value of the UserDefined1 property of the user from a local user list during password matching of local users.

## User-Authorization-Script

**User-Authorization-Script** is read in local services during authorization. If set, the server calls the specified script to do additional user authorization after authentication succeeds.

## User-Group

**User-Group** is read in local services during authorization. If set, species the UserGroup to which the current user belongs.

## User-Group-Session-Limit

**User-Group-Session-Limit** is read during session management. If set, **User-Group-Session-Limit** overrides the limit specified for the group-session-limit resource manager.

## User-Name

**User-Name** is read by a local service during authentication. When **User-Name** is set, it is the name used to authenticate or authorize the request and overrides the **User-Name** in the Request dictionary.

## User-Profile

**User-Profile** is read in local services during authorization. If set, **User-Profile** specifies the Profile from which the current user should receive attributes.

## User-Session-Limit

**User-Session-Limit** is read during session management. If set, **User-Session-Limit** overrides the limit specified for the user-session-limit resource manager.

## Virtual-Server-Outgoing-Script

Virtual-Server-Outgoing-Script is read when LawfulIntercept script object is enabled to use virtaul script object. If this is set, the configured script will be executed after server outgoing script.

## Windows-Domain-Groups

The Windows-Domain-Groups variable is a read-only variable that contains a comma separated list of group names to which the user belongs in the Active Directory. The Windows-Domain-Groups variable is set after a successful authentication using a *domain-auth* type of service.

## X509- Subject-Name

X509- Subject-Name reads the value of the subject in the SSL certificate. This is read while processing the access request.

# Internal Variables

The following environment variables are used by the server for internal operation. The values for these environment variables must not be modified.

- Add-Message-Authenticator
- Calling-Service-Name
- Cleartext-Password
- Current-Service-Name
- Dynamic-Search-UID
- Duplicate-Req
- EAP-Internal-Services
- Group-Service
- Group-Service-State-ID
- Hidden-Attrib
- IMSI
- Local-Port-type
- Message-Authenticator-Present
- MSCHAP-Account-Name
- MS-ChapV2-Message
- NAS-Name-And-IPAddress
- Notify-Service-Session-Key
- Notify-Service-State-ID
- Number-Requested-Quintets
- Number-Requested-Triplets
- Proxied-Dynamic-Auth (named Proxied-POD in earlier releases)
- Provider-Identifier
- Rcd-NT-Password-Hash-Hash (named Rcd-NT-Password-Hash in earlier releases)
- Remote-Session
- Return-Data
- Roaming
- Script-Level
- Session-ID
- Session-Accounting-Counter
- Session-Generation-Tag
- Session-Last-Accessed-Time
- Session-Manager-Key
- Session-NAS-Identifier
- Session-NAS-Port

- Session-Resource-Count
- Session-Resource-%d
- Session-Reuse
- Session-Start-Time
- Session-Survives-NAS-Reboot
- Session-User-Name
- User-Name-Used-For-Lookup
- WiMax-Authentication
- WiMax-SessionManager-Exists



## RADIUS Attributes

---

This appendix lists the attributes Cisco Prime Access Registrar (Cisco Prime AR) supports with their names and values. RADIUS attributes carry the specific authentication, authorization information, and configuration details for requests and replies. For more detailed information about specific attributes, see the appropriate RFC as listed [Table C-1](#).

**Table C-1** *RFCs for RADIUS Attributes*

| RFC Subject                                          | RFC Number |
|------------------------------------------------------|------------|
| Standard RADIUS Attributes                           | 2865       |
| RADIUS Accounting Attributes                         | 2866       |
| Accounting Modifications for Tunnel Protocol Support | 2867       |
| Attributes for Tunnel Protocol Support               | 2868       |
| RADIUS Extensions                                    | 2869       |

This appendix has two sections:

[RADIUS Attributes](#)—This section provides an alphabetic list of all RADIUS attributes Cisco Prime AR supports and a list of all RADIUS attributes in numeric order.

[Vendor-Specific Attributes](#)—This section provides lists of RADIUS vendor-specific attributes (VSAs).

## RADIUS Attributes

This section lists the RADIUS attributes supported in Cisco Prime AR. RADIUS attributes carry specific authentication, authorization, information, and configuration details in the Access-Request and the RADIUS server response.

## Cisco Prime Access Registrar Attributes

This section provides an alphabetical list of all attributes used in Cisco Prime AR and the attribute number.

**Table C-2 RADIUS Attributes Alphabetical List**

| <b>Attribute Name</b>       | <b>Attribute Number</b> |
|-----------------------------|-------------------------|
| Acct-Authentic              | 45                      |
| Acct-Delay-Time             | 41                      |
| Acct-Input-Gigawords        | 52                      |
| Acct-Input-Octets           | 42                      |
| Acct-Input-Packets          | 47                      |
| Acct-Interim-Interval       | 85                      |
| Acct-Link-Count             | 51                      |
| Acct-Multi-Session-Id       | 50                      |
| Acct-Output-Gigawords       | 53                      |
| Acct-Output-Octets          | 43                      |
| Acct-Output-Packets         | 48                      |
| Acct-Session-Id             | 44                      |
| Acct-Session-Time           | 46                      |
| Acct-Status-Type            | 40                      |
| Acct-Terminate-Cause        | 49                      |
| Acct-Tunnel-Connection      | 68                      |
| Acct-Tunnel-Packets-Lost    | 86                      |
| Acquire-Group-Session-Limit | 280                     |
| ARAP-Challenge-Response     | 84                      |
| ARAP-Features               | 71                      |
| ARAP-Password               | 70                      |
| ARAP-Security               | 73                      |
| ARAP-Security-Data          | 74                      |
| ARAP-Zone-Access            | 72                      |
| Callback-Id                 | 20                      |
| Callback-Number             | 19                      |
| Called-Station-Id           | 30                      |
| Calling-Station-Id          | 31                      |
| Change-Password             | 17                      |
| CHAP-Challenge              | 60                      |
| CHAP-Password               | 3                       |
| Class                       | 25                      |
| Configuration-Token         | 78                      |
| Connect-Info                | 77                      |
| Digest-Attributes           | 207                     |
| Digest-Response             | 206                     |

**Table C-2 RADIUS Attributes Alphabetical List (continued)**

| <b>Attribute Name</b>    | <b>Attribute Number</b> |
|--------------------------|-------------------------|
| EAP-Message              | 79                      |
| Error-Cause              | 101                     |
| Event-Timestamp          | 55                      |
| Filter-Id                | 11                      |
| Framed-AppleTalk-Link    | 37                      |
| Framed-AppleTalk-Network | 38                      |
| Framed-AppleTalk-Zone    | 39                      |
| Framed-Compression       | 13                      |
| Framed-Interface-Id      | 96                      |
| Framed-IP-Address        | 8                       |
| Framed-IP-Netmask        | 9                       |
| Framed-IPv6-Pool         | 100                     |
| Framed-IPv6-Prefix       | 97                      |
| Framed-IPv6-Route        | 99                      |
| Framed-IPX-Network       | 12                      |
| Framed-MTU               | 12                      |
| Framed-Pool              | 88                      |
| Framed-Protocol          | 7                       |
| Framed-Route             | 22                      |
| Framed-Routing           | 10                      |
| Idle-Timeout             | 28                      |
| Login-IP-Host            | 14                      |
| Login-IPv6-Host          | 98                      |
| Login-LAT-Group          | 36                      |
| Login-LAT-Node           | 35                      |
| Login-LAT-Port           | 63                      |
| Login-LAT-Service        | 34                      |
| Login-Service            | 15                      |
| Login-TCP-Port           | 16                      |
| Message-Authenticator    | 80                      |
| NAS-Identifier           | 32                      |
| NAS-IP-Address           | 4                       |
| NAS-IPv6-Address         | 95                      |
| NAS-Port                 | 5                       |
| NAS-Port-ID              | 87                      |
| NAS-Port-Type            | 61                      |

**Table C-2** RADIUS Attributes Alphabetical List (continued)

| Attribute Name             | Attribute Number |
|----------------------------|------------------|
| Originating-Line-Info      | 94               |
| Password-Expiration        | 21               |
| Password-Retry             | 75               |
| Port-Limit                 | 62               |
| Prompt                     | 76               |
| Proxy-State                | 33               |
| Reply-Message              | 18               |
| Service-Type               | 6                |
| Session-Timeout            | 27               |
| State                      | 24               |
| Termination-Action         | 29               |
| Text-Ascend-Data-Filter    | 225              |
| Tunnel-Assignment-ID       | 82               |
| Tunnel-Client-Auth-ID      | 90               |
| Tunnel-Client-Endpoint     | 66               |
| Tunnel-Medium-Type         | 65               |
| Tunnel-Password            | 69               |
| Tunnel-Preference          | 83               |
| Tunnel-Private-Group-ID    | 81               |
| Tunnel-Server-Auth-ID      | 91               |
| Tunnel-Server-Endpoint     | 67               |
| Tunnel-Type                | 64               |
| User-Name                  | 1                |
| User-Password              | 2                |
| Vendor-Specific Attributes | 26               |

## RADIUS Attributes Numeric List

Table C-3 lists all RFC-defined RADIUS attributes in numeric order.

**Table C-3** RADIUS Attributes Numeric List

| Number | Attribute Name |
|--------|----------------|
| 1      | User-Name      |
| 2      | User-Password  |
| 3      | CHAP-Password  |
| 4      | NAS-IP-Address |



**Table C-3 RADIUS Attributes Numeric List (continued)**

| <b>Number</b> | <b>Attribute Name</b> |
|---------------|-----------------------|
| 5             | NAS-Port              |
| 6             | Service-Type          |
| 7             | Framed-Protocol       |
| 8             | Framed-IP-Address     |
| 9             | Framed-IP-Netmask     |
| 10            | Framed-Routing        |
| 11            | Filter-Id             |
| 12            | Framed-MTU            |
| 13            | Framed-Compression    |
| 14            | Login-IP-Host         |
| 15            | Login-Service         |
| 16            | Login-TCP-Port        |
| 17            | Change-Password       |
| 18            | Reply-Message         |
| 19            | Callback-Number       |
| 20            | Callback-Id           |
| 21            | Password-Expiration   |
| 22            | Framed-Route          |
| 12            | Framed-IPX-Network    |
| 24            | State                 |
| 25            | Class                 |

**Table C-3 RADIUS Attributes Numeric List (continued)**

| Number | Attribute Name                                                                                                                                                                                                                                                                                                                                                                                                                                                                                                                                                                                                                                                                                                                                                                                                                                                                                                                                                                                                             |
|--------|----------------------------------------------------------------------------------------------------------------------------------------------------------------------------------------------------------------------------------------------------------------------------------------------------------------------------------------------------------------------------------------------------------------------------------------------------------------------------------------------------------------------------------------------------------------------------------------------------------------------------------------------------------------------------------------------------------------------------------------------------------------------------------------------------------------------------------------------------------------------------------------------------------------------------------------------------------------------------------------------------------------------------|
| 26     | <p>Vendor-Specific Attributes (VSAs)</p> <p>See <a href="#">Vendor-Specific Attributes, page C-13</a> or the specific vendor's VSA list:</p> <ul style="list-style-type: none"> <li>• <a href="#">3GPP VSAs</a></li> <li>• <a href="#">3GPP2 VSAs</a></li> <li>• <a href="#">ACC VSAs</a></li> <li>• <a href="#">Altiga VSAs</a></li> <li>• <a href="#">Ascend VSAs</a></li> <li>• <a href="#">Bay Networks VSAs</a></li> <li>• <a href="#">Cabletron VSAs</a></li> <li>• <a href="#">Cisco Prime Access Registrar Internal VSAs</a></li> <li>• <a href="#">Cisco VSAs</a></li> <li>• <a href="#">Compatible VSAs</a></li> <li>• <a href="#">Microsoft VSAs</a></li> <li>• <a href="#">Nomadix VSAs</a></li> <li>• <a href="#">RedBack VSAs</a></li> <li>• <a href="#">RedCreek VSAs</a></li> <li>• <a href="#">Telebit VSAs</a></li> <li>• <a href="#">Unisphere VSAs</a></li> <li>• <a href="#">USR VSAs</a></li> <li>• <a href="#">WiMax</a></li> <li>• <a href="#">WISPr</a></li> <li>• <a href="#">XML</a></li> </ul> |
| 27     | Session-Timeout                                                                                                                                                                                                                                                                                                                                                                                                                                                                                                                                                                                                                                                                                                                                                                                                                                                                                                                                                                                                            |
| 28     | Idle-Timeout                                                                                                                                                                                                                                                                                                                                                                                                                                                                                                                                                                                                                                                                                                                                                                                                                                                                                                                                                                                                               |
| 29     | Termination-Action                                                                                                                                                                                                                                                                                                                                                                                                                                                                                                                                                                                                                                                                                                                                                                                                                                                                                                                                                                                                         |
| 30     | Called-Station-ID (DNIS)                                                                                                                                                                                                                                                                                                                                                                                                                                                                                                                                                                                                                                                                                                                                                                                                                                                                                                                                                                                                   |
| 31     | Calling-Station-ID (CLID)                                                                                                                                                                                                                                                                                                                                                                                                                                                                                                                                                                                                                                                                                                                                                                                                                                                                                                                                                                                                  |
| 32     | NAS-Identifier                                                                                                                                                                                                                                                                                                                                                                                                                                                                                                                                                                                                                                                                                                                                                                                                                                                                                                                                                                                                             |
| 33     | Proxy-State                                                                                                                                                                                                                                                                                                                                                                                                                                                                                                                                                                                                                                                                                                                                                                                                                                                                                                                                                                                                                |
| 34     | Login-LAT-Service                                                                                                                                                                                                                                                                                                                                                                                                                                                                                                                                                                                                                                                                                                                                                                                                                                                                                                                                                                                                          |
| 35     | Login-LAT-Node                                                                                                                                                                                                                                                                                                                                                                                                                                                                                                                                                                                                                                                                                                                                                                                                                                                                                                                                                                                                             |
| 36     | Login-LAT-Group                                                                                                                                                                                                                                                                                                                                                                                                                                                                                                                                                                                                                                                                                                                                                                                                                                                                                                                                                                                                            |
| 37     | Framed-AppleTalk-Link                                                                                                                                                                                                                                                                                                                                                                                                                                                                                                                                                                                                                                                                                                                                                                                                                                                                                                                                                                                                      |

**Table C-3** RADIUS Attributes Numeric List (continued)

| Number | Attribute Name           |
|--------|--------------------------|
| 38     | Framed-AppleTalk-Network |
| 39     | Framed-AppleTalk-Zone    |
| 40     | Acct-Status-Type         |
| 41     | Acct-Delay-Time          |
| 42     | Acct-Input-Octets        |
| 43     | Acct-Output-Octets       |
| 44     | Acct-Session-Id          |
| 45     | Acct-Authentic           |
| 46     | Acct-Session-Time        |
| 47     | Acct-Input-packets       |
| 48     | Acct-Output-packets      |
| 49     | Acct-Terminate-Cause     |
| 50     | Acct-Multi-Session-Id    |
| 51     | Acct-Link-Count          |
| 52     | Acct-Input-Gigawords     |
| 53     | Acct-Output-Gigawords    |
| 54     | unassigned               |
| 55     | Event-Timestamp          |
| 56     | unassigned               |
| 57     | unassigned               |
| 58     | unassigned               |
| 59     | unassigned               |
| 60     | CHAP-Challenge           |
| 61     | NAS-Port-Type            |
| 62     | Port-Limit               |
| 63     | Login-LAT-PortNo         |
| 64     | Tunnel-Type              |
| 65     | Tunnel-Medium-Type       |
| 66     | Tunnel-Client-Endpoint   |
| 67     | Tunnel-Server-Endpoint   |
| 68     | Acct-Tunnel-Connection   |
| 68     | Tunnel-ID                |
| 69     | Tunnel-Password          |
| 70     | ARAP-Password            |
| 71     | ARAP-Features            |
| 72     | ARAP-Zone-Access         |

**Table C-3** RADIUS Attributes Numeric List (continued)

| Number | Attribute Name              |
|--------|-----------------------------|
| 73     | ARAP-Security               |
| 74     | ARAP-Security-Data          |
| 75     | Password-Retry              |
| 76     | Prompt                      |
| 77     | Connect-Info                |
| 78     | Configuration-Token         |
| 79     | EAP-Message                 |
| 80     | Message-Authenticator       |
| 81     | Tunnel-Private-Group-ID     |
| 81     | Ascend-Auth-Type            |
| 82     | Tunnel-Assignment-ID        |
| 83     | Tunnel-Preference           |
| 84     | ARAP-Challenge-Response     |
| 85     | Acct-Interim-Interval       |
| 85     | Ascend-IP-Pool-Chaining     |
| 86     | Acct-Tunnel-Packets-Lost    |
| 87     | NAS-Port-ID                 |
| 88     | Framed-Pool                 |
| 88     | Ascend-IP-TOS               |
| 89     | Ascend-IP-TOS-Precedence    |
| 90     | Tunnel-Client-Auth-ID       |
| 90     | Ascend-IP-TOS-Apply-To      |
| 91     | Tunnel-Server-Auth-ID       |
| 91     | Ascend-Filter               |
| 92     | Ascend-Dsl-Rate-Type        |
| 93     | Ascend-Redirect-Number      |
| 94     | Originating-Line-Info       |
| 95     | Ascend-ATM-Vci              |
| 96     | Ascend-Source-IP-Check      |
| 97     | Ascend-Dsl-Rate-Mode        |
| 98     | Ascend-Dsl-Upstream-Limit   |
| 99     | Ascend-Dsl-Downstream-Limit |
| 100    | Ascend-Dsl-CIR-Recv-Limit   |
| 101    | Error-Cause                 |
| 102    | EAP-Key-Name                |
| 103    | Ascend-Source-Auth          |

**Table C-3** RADIUS Attributes Numeric List (continued)

| Number | Attribute Name                |
|--------|-------------------------------|
| 104    | Ascend-Private-Route          |
| 105    | unassigned                    |
| 106    | Ascend-FR-Link-Status-DLCI    |
| 107    | unassigned                    |
| 108    | Ascend-Callback-Delay         |
| 109    | unassigned                    |
| 110    | unassigned                    |
| 111    | Ascend-Multicast-GLeave-Delay |
| 112    | Ascend-CBCP-Enable            |
| 113    | Ascend-CBCP-Mode              |
| 114    | unassigned                    |
| 115    | Ascend-CBCP-Trunk-Group       |
| 116    | Ascend-Appletalk-Route        |
| 117    | Ascend-Appletalk-Peer-Mode    |
| 118    | Ascend-Route-Appletalk        |
| 119    | unassigned                    |
| 120    | Ascend-Modem-PortNo           |
| 121    | Ascend-Modem-SlotNo           |
| 122    | unassigned                    |
| 112    | unassigned                    |
| 124    | unassigned                    |
| 125    | Ascend-Maximum-Call-Duration  |
| 126    | Ascend-Preference             |
| 127    | Tunneling-Protocol            |
| 128    | Ascend-Shared-Profile-Enable  |
| 129    | Ascend-Primary-Home-Agent     |
| 130    | Ascend-Secondary-Home-Agent   |
| 131    | Ascend-Dialout-Allowed        |
| 132    | Ascend-Client-Gateway         |
| 133    | Ascend-BACP-Enable            |
| 134    | Ascend-DHCP-Maximum-Leases    |
| 135    | Ascend-Client-Primary-DNS     |
| 136    | Ascend-Client-Secondary-DNS   |
| 137    | Ascend-Client-Assign-DNS      |
| 138    | Ascend-User-Acct-Type         |
| 139    | Ascend-User-Acct-Host         |

**Table C-3 RADIUS Attributes Numeric List (continued)**

| <b>Number</b> | <b>Attribute Name</b>        |
|---------------|------------------------------|
| 140           | Ascend-User-Acct-Port        |
| 141           | Ascend-User-Acct-Key         |
| 142           | Ascend-User-Acct-Base        |
| 143           | Ascend-User-Acct-Time        |
| 144           | Ascend-Assign-IP-Client      |
| 145           | Ascend-Assign-IP-Server      |
| 146           | Ascend-Assign-IP-Global-Pool |
| 147           | Ascend-DHCP-Reply            |
| 148           | Ascend-DHCP-Pool-Number      |
| 149           | Ascend-Expect-Callback       |
| 150           | Ascend-Event-Type            |
| 151           | Ascend-Session-Svr-Key       |
| 152           | Ascend-Multicast-Rate-Limit  |
| 153           | Ascend-IF-Netmask            |
| 154           | Ascend-Remote-Addr           |
| 155           | Ascend-Multicast-Client      |
| 156           | Ascend-FR-Circuit-Name       |
| 157           | Ascend-FR-LinkUp             |
| 158           | Ascend-FR-Nailed-Grp         |
| 159           | Ascend-FR-Type               |
| 160           | Ascend-FR-Link-Mgt           |
| 161           | Ascend-FR-N391               |
| 162           | Ascend-FR-DCE-N392           |
| 163           | Ascend-FR-DTE-N392           |
| 164           | Ascend-FR-DCE-N393           |
| 165           | Ascend-FR-DTE-N393           |
| 166           | Ascend-FR-T391               |
| 167           | Ascend-FR-T392               |
| 168           | Ascend-Bridge-Address        |
| 169           | Ascend-TS-Idle-Limit         |
| 170           | Ascend-TS-Idle-Mode          |
| 171           | Ascend-DBA-Monitor           |
| 172           | Ascend-Base-Channel-Count    |
| 173           | Ascend-Minimum-Channels      |
| 174           | Ascend-IPX-Route             |
| 175           | Ascend-FT1-Caller            |

**Table C-3** RADIUS Attributes Numeric List (continued)

| Number | Attribute Name                    |
|--------|-----------------------------------|
| 176    | Ascend-backup                     |
| 177    | Ascend-Call-Type                  |
| 178    | Ascend-Group                      |
| 179    | Ascend-FR-DLCI                    |
| 180    | Ascend-FR-Profile-Name            |
| 181    | Ascend-Ara-PW                     |
| 182    | Ascend-IPX-Node-Addr              |
| 183    | Ascend-Home-Agent-IP-Addr         |
| 184    | Ascend-Home-Agent-Password        |
| 185    | Ascend-Home-Network-Name          |
| 186    | Ascend-Home-Agent-UDP-Port        |
| 187    | Ascend-Multilink-ID supported     |
| 188    | Ascend-Num-In-Multilink           |
| 189    | Ascend-First-Dest (Not supported) |
| 190    | Ascend-Pre-Input-Octets           |
| 191    | Ascend-Pre-Output-Octets          |
| 192    | Ascend-Pre-Input-packets          |
| 193    | Ascend-Pre-Output-packets         |
| 194    | Ascend-Maximum-Time               |
| 195    | Ascend-Disconnect-Cause           |
| 196    | Ascend-Connect-Progress           |
| 197    | Ascend-Data-Rate                  |
| 198    | Ascend-PreSession-Time            |
| 199    | Ascend-Token-Idle                 |
| 200    | Ascend-Token-Immediate            |
| 201    | Ascend-Require-Auth               |
| 202    | Ascend-Number-Sessions            |
| 203    | Ascend-Authen-Alias               |
| 204    | Ascend-Token-Expiry               |
| 205    | Ascend-Menu-Selector              |
| 206    | Digest-Response                   |
| 207    | Digest-Attributes                 |
| 208    | Ascend-PW-Lifetime                |
| 209    | Ascend-IP-Direct                  |
| 210    | Ascend-PPP-VJ-Slot-Comp           |
| 211    | Ascend-PPP-VJ-1172                |

**Table C-3 RADIUS Attributes Numeric List (continued)**

| <b>Number</b> | <b>Attribute Name</b>     |
|---------------|---------------------------|
| 212           | Ascend-PPP-Async-Map      |
| 213           | Ascend-Third-Prompt       |
| 214           | Ascend-Send-Secret        |
| 215           | Ascend-Receive-Secret     |
| 216           | Ascend-IPX-Peer-Mode      |
| 217           | Ascend-IP-Pool-Definition |
| 218           | Ascend-Assign-IP-Pool     |
| 219           | Ascend-FR-Direct          |
| 220           | Ascend-FR-Direct-Profile  |
| 221           | Ascend-FR-Direct-DLCI     |
| 222           | Ascend-Handle-IPX         |
| 212           | Ascend-Netware-timeout    |
| 224           | Ascend-IPX-Alias          |
| 225           | Ascend-Metric             |
| 226           | Ascend-PRI-Number-Type    |
| 227           | Ascend-Dial-Number        |
| 228           | Ascend-Route-IP           |
| 229           | Ascend-Route-IPX          |
| 120           | Ascend-Bridge             |
| 121           | Ascend-Send-Auth          |
| 122           | Ascend-Send-Passwd        |
| 123           | Ascend-Link-Compression   |
| 124           | Ascend-Target-Util        |
| 125           | Ascend-Maximum-Channels   |
| 126           | Ascend-Inc-Channel-Count  |
| 127           | Ascend-Dec-Channel-Count  |
| 128           | Ascend-Seconds-Of-History |
| 129           | Ascend-History-Weigh-Type |
| 240           | Ascend-Add-Seconds        |
| 241           | Ascend-Remove-Seconds     |
| 242           | Ascend-Data-Filter        |
| 243           | Ascend-Call-Filter        |
| 244           | Ascend-Idle-Limit         |
| 245           | Ascend-Preempt-Limit      |
| 246           | Ascend-Callback           |
| 247           | Ascend-Data-Svc           |



**Table C-3** RADIUS Attributes Numeric List (continued)

| Number | Attribute Name             |
|--------|----------------------------|
| 248    | Ascend-Force-56            |
| 249    | Ascend-Billing-Number      |
| 250    | Ascend-Call-By-Call        |
| 251    | Ascend-Transit-Number      |
| 252    | Ascend-Host-Info           |
| 253    | Ascend-PPP-Address         |
| 254    | Ascend-MPP-Idle-Percent    |
| 255    | Ascend-Xmit-Rate           |
| 256    | HNB Parameters             |
| 257    | Macro-Coverage-Information |
| 258    | Geographical Location      |
| 259    | HNB Internet Information   |
| 260    | Reject Cause               |
| 270    | White-List                 |

## Vendor-Specific Attributes

This section lists all vendor-specific attributes (VSAs) supported by Cisco Prime AR.

### 3GPP VSAs

Table C-4 lists the 3GPP VSAs. The vendor ID for 3GPP VSAs is 10415.

**Table C-4** 3GPP VSAs

| SubAttr | VSA Name              | Type       | Min-Max Value                          |
|---------|-----------------------|------------|----------------------------------------|
| 1       | 3GPP-IMSI             | String     | 0-15                                   |
| 2       | 3GPP-Charging-Id      | UINT       | 0-65535                                |
| 3       | 3GPP-PDPTtype         | ENUM       | 0-2<br>0 = IPv4<br>1 = PPP<br>2 = IPv6 |
| 4       | 3GPP-OG-Address       | IP Address |                                        |
| 5       | 3GPP-GPRS-QoS-Profile | String     | 0-31                                   |
| 6       | 3GPP-SGSN-Address     | IP Address |                                        |
| 7       | 3GPP-GGSN-Address     | IP Address |                                        |

Table C-4 3GPP VSAs (continued)

| SubAttr | VSA Name                      | Type   | Min-Max Value |
|---------|-------------------------------|--------|---------------|
| 8       | 3GPP-IMSI-MCC-MNC             | String | 6-6           |
| 9       | 3GPP-GGSN-MCC-MNC             | String | 6-6           |
| 10      | 3GPP-NSAPI                    | String | 1-1           |
| 11      | 3GPP-Session-Stop-Indicator   | String | 2-2           |
| 12      | 3GPP-Selection-Mode           | String | 1-1           |
| 13      | 3GPP-Charging-Characteristics | String | 4-4           |
| 14      | 3GPP-CG-IPv6-Address          | String | 16-16         |
| 15      | 3GPP-SGSN-IPv6-Address        | String | 16-16         |
| 16      | 3GPP-GGSN-IPv6-Address        | String | 6-6           |
| 17      | 3GPP-IPv6-DNS-Servers         | String | 16-253        |
| 18      | 3GPP-SGSN-MCC-MNC             | String | 0-1           |
| 19      | 3GPP-Teardown-Indicator       | UINT32 | 0-1           |
| 20      | 3GPP-IMEISV                   | String | 16-16         |
| 21      | 3GPP-RAT-Type                 | String | 1-1           |
| 22      | 3GPP-User-Location-Info       | String | 0-253         |
| 12      | 3GPP-MS-Timezone              | String | 2-2           |
| 24      | 3GPP-Camel-Charging-Info      | String | 0-253         |
| 25      | 3GPP-Packet-Filter            | String | 0-253         |
| 26      | 3GPP-Negotiated-DSCP          | String | 1-1           |

## 3GPP2 VSAs

Table C-5 lists the 3GPP2 VSAs. The vendor ID for 3GPP2 VSAs is 5535 with 8-bit VendorTypeSize.

**Table C-5 3GPP2 VSAs**

| SubAttr | VSA Name                           | Type       | Min-Max Value                                                                                                                                                                                   |
|---------|------------------------------------|------------|-------------------------------------------------------------------------------------------------------------------------------------------------------------------------------------------------|
| 1       | CDMA-IKE-Pre-Shared-Secret-Request | ENUM       | 1-2;<br>1 = The PDSN requests a pre-shared secret for IKE<br>2 = The PDSN does not request a pre-shared secret for IKE                                                                          |
| 2       | CDMA-Security-Level                | ENUM       | 1-4;<br>1 = IPSec for registration messages<br>2 = IPSec for tunnels<br>3 = IPSec for tunnels and registration messages<br>4 = No IPSec security                                                |
| 3       | CDMA-Pre-Shared-Secret             | String     | 0-24                                                                                                                                                                                            |
| 4       | CDMA-Reverse-Tunnel-Spec           | ENUM       | 0-1;<br>0 = Reverse tunneling is not required<br>1 = Reverse tunneling is required                                                                                                              |
| 5       | CDMA-Diff-Svc-Class-Opt            | ENUM       | 0-46;<br>0 = Best Effort<br>10 = AF11<br>12 = AF12<br>14 = AF13<br>18 = AF21<br>20 = AF22<br>22 = AF12<br>26 = AF31<br>28 = AF32<br>30 = AF33<br>34 = AF41<br>36 = AF42<br>38 = AF43<br>46 = EF |
| 6       | CDMA-Container                     | String     | 0-253                                                                                                                                                                                           |
| 7       | CDMA-HA-IP-Addr                    | IPADDR     |                                                                                                                                                                                                 |
| 8       | CDMA-KeyID-Attribute               | String     | 0-28                                                                                                                                                                                            |
| 9       | CDMA-PCF-IP-Addr                   | IP Address |                                                                                                                                                                                                 |
| 10      | CDMA-BS-MS-Addr                    | String     | 0-253                                                                                                                                                                                           |

Table C-5 3GPP2 VSAs (continued)

| SubAttr | VSA Name            | Type       | Min-Max Value                                                                           |
|---------|---------------------|------------|-----------------------------------------------------------------------------------------|
| 11      | CDMA-User-ID        | UINT3<br>2 | 0-0                                                                                     |
| 12      | CDMA-Forward-MUX    | UINT3<br>2 | 0-0                                                                                     |
| 13      | CDMA-Reverse-MUX    | UINT3<br>2 | 0-0                                                                                     |
| 14      | CDMA-Forward-Rate   | UINT3<br>2 | 0-0                                                                                     |
| 15      | CDMA-Reverse-Rate   | UINT3<br>2 | 0-0                                                                                     |
| 16      | CDMA-Service-Option | UINT3<br>2 | 0-0                                                                                     |
| 17      | CDMA-Forward-Type   | ENUM       | 0-1;<br>0 = Primary<br>1 = Secondary                                                    |
| 18      | CDMA-Reverse-Type   | ENUM       | 0-1;<br>0 = Primary<br>1 = Secondary                                                    |
| 19      | CDMA-Frame-Size     | ENUM       | 0-2;<br>0 = No Fundamental<br>1 = 5 ms Frame and 20ms Mixed<br>Frame<br>2 = 20 ms Frame |
| 20      | CDMA-Forward-RC     | UINT3<br>2 | 0-0                                                                                     |
| 21      | CDMA-Reverse-RC     | UINT3<br>2 | 0-0                                                                                     |
| 22      | CDMA-IP-Technology  | ENUM       | 1-3;<br>1 = Simple-IP<br>2 = Mobile-IP<br>3 = Proxy-Mobile-IP                           |
| 12      | CDMA-Comp-Flag      | ENUM       | 0-2;<br>0 = None<br>1 = Non-secure<br>2 = Secure                                        |

Table C-5 3GPP2 VSAs (continued)

| SubAttr | VSA Name               | Type       | Min-Max Value                                                                                                                                                                                                                                                                                                                                                                                                                                                                                                                                                                 |
|---------|------------------------|------------|-------------------------------------------------------------------------------------------------------------------------------------------------------------------------------------------------------------------------------------------------------------------------------------------------------------------------------------------------------------------------------------------------------------------------------------------------------------------------------------------------------------------------------------------------------------------------------|
| 24      | CDMA-Release-Ind       | ENUM       | 0-14;<br>0 = Unknown<br>1 = PPP/Service timeout<br>2 = Handoff<br>3 = PPP termination<br>4 = Mobile IP registration failure<br>5 = Abnormal Terminations<br>6 = Termination due to Resource management<br>7 = Service instance released<br>8 = Volume Quota reached, service instance released<br>9 = Duration Quota reached, Service instance released<br>10 = Incompatible PrePaid accounting information<br>11 = Airlink Parameter Change<br>12 = Time of Day Timer expiration<br>13 = Dormant by Accounting-Stop-triggered-by-Active-Stop<br>14 = Hot-Line status changed |
| 25      | CDMA-Dropped-Octets    | UINT3<br>2 | 0-0                                                                                                                                                                                                                                                                                                                                                                                                                                                                                                                                                                           |
| 26      | CDMA-Start-Date        | String     | 0-253                                                                                                                                                                                                                                                                                                                                                                                                                                                                                                                                                                         |
| 27      | CDMA-Start-Time        | String     | 0-253                                                                                                                                                                                                                                                                                                                                                                                                                                                                                                                                                                         |
| 28      | CDMA-Stop-Date         | String     | 0-253                                                                                                                                                                                                                                                                                                                                                                                                                                                                                                                                                                         |
| 29      | CDMA-Stop-Time         | String     | 0-253                                                                                                                                                                                                                                                                                                                                                                                                                                                                                                                                                                         |
| 30      | CDMA-Num-Active        | UINT3<br>2 | 0-0                                                                                                                                                                                                                                                                                                                                                                                                                                                                                                                                                                           |
| 31      | CDMA-SDB-Input-Octets  | UINT3<br>2 | 0-0                                                                                                                                                                                                                                                                                                                                                                                                                                                                                                                                                                           |
| 32      | CDMA-SDB-Output-Octets | UINT3<br>2 | 0-0                                                                                                                                                                                                                                                                                                                                                                                                                                                                                                                                                                           |
| 33      | CDMA-NumSDB-Input      | UINT3<br>2 | 0-0                                                                                                                                                                                                                                                                                                                                                                                                                                                                                                                                                                           |
| 34      | CDMA-NumSDB-Output     | UINT3<br>2 | 0-0                                                                                                                                                                                                                                                                                                                                                                                                                                                                                                                                                                           |

Table C-5 3GPP2 VSAs (continued)

| SubAttr | VSA Name                                  | Type       | Min-Max Value                                                                         |
|---------|-------------------------------------------|------------|---------------------------------------------------------------------------------------|
| 35      | CDMA-Alt-Billing                          | UINT3<br>2 | 0-0                                                                                   |
| 36      | CDMA-IP-QoS                               | UINT3<br>2 | 0-0                                                                                   |
| 37      | CDMA-Interconnect-IP                      | UINT3<br>2 | 0-0                                                                                   |
| 38      | CDMA-Interconnect-QoS                     | UINT3<br>2 | 0-0                                                                                   |
| 39      | CDMA-Air-QoS                              | UINT3<br>2 | 0-0                                                                                   |
| 40      | CDMA-Airlink-Record-Type                  | ENUM       | 1-4;<br>1 = Connection Setup<br>2 = Active Start<br>3 = Active Stop<br>4 = SDB Record |
| 41      | CDMA-R-P-Link-ID                          | UINT3<br>2 | 0-0                                                                                   |
| 42      | CDMA-Airlink-Record-Type                  | UINT3<br>2 | 0-0                                                                                   |
| 43      | CDMA-PPP-Bytes-Received                   | UINT3<br>2 | 0-0                                                                                   |
| 44      | CDMA-Correlation-ID                       | String     | 0-253                                                                                 |
| 45      | CDMA-Mobile-Terminate-Originated-Ind      | UINT3<br>2 | 0-0                                                                                   |
| 46      | CDMA-Inbound-Mobile-IP-Signalling-Octets  | UINT3<br>2 | 0-0                                                                                   |
| 47      | CDMA-Outbound-Mobile-IP-Signalling-Octets | UINT3<br>2 | 0-0                                                                                   |
| 48      | CDMA-Session-Continue                     | ENUM       | 0-1;<br>0 = False<br>1 = True                                                         |
| 49      | CDMA-Active-Time                          | UINT3<br>2 | 0-0                                                                                   |
| 50      | CDMA-DCCH-Frame-Format                    | UINT3<br>2 | 0-3                                                                                   |
| 51      | CDMA-Beginning-Session                    | ENUM       | 0-1;<br>0 = False<br>1 = True                                                         |
| 52      | CDMA-ESN                                  | String     | 0-253                                                                                 |
| 54      | CDMA-S-Attribute                          | String     | 0-253                                                                                 |

Table C-5 3GPP2 VSAs (continued)

| SubAttr | VSA Name                                    | Type       | Min-Max Value                                                                                    |
|---------|---------------------------------------------|------------|--------------------------------------------------------------------------------------------------|
| 55      | CDMA-S-Request-Attribute                    | ENUM       | 0-1;<br>0 = The HA does not request a S secret for IKE<br>1 = The HA requests a S secret for IKE |
| 56      | CDMA-S-Lifetime-Attribute                   | UINT32     | 0-0                                                                                              |
| 57      | CDMA-MN-HA-SPI                              | String     | 0-4                                                                                              |
| 58      | CDMA-MN-HA-Shared-Key                       | String     | 0-253                                                                                            |
| 59      | CDMA-Remote-IPv4-Address                    | String     | 12-253                                                                                           |
| 60      | CDMA-HRPD-Access-Authentication             | ENUM       | 1-1;<br>1 = HRPD Access Authentication                                                           |
| 70      | CDMA-Remote-IPv6-Address                    | String     | 68-253                                                                                           |
| 71      | CDMA-Remote-Address-Table-Index             | UINT32     | 0-253                                                                                            |
| 72      | CDMA-Remote-IPv4-Address-Octet-Count        | String     | 24-253                                                                                           |
| 73      | CDMA-Allowed-Differentiated-Service-Marking | String     | 12-253                                                                                           |
| 74      | CDMA-Service-Option-Profile                 | String     | 8-253                                                                                            |
| 75      | CDMA-DNS-Update-Required                    | ENUM       | 0-1;<br>0 = HA does not need to send DNS Update<br>1 = HA does need to send DNS Update           |
| 78      | CDMA-Always-On                              | ENUM       | 0-1;<br>0 = Inactive<br>1 = Active                                                               |
| 79      | CDMA-Foreign-Agent-Address                  | IP Address |                                                                                                  |
| 80      | CDMA-Last-User-Activity                     | UINT32     | 0-0                                                                                              |
| 81      | CDMA-MN-AAA-Removal-Indication              | ENUM       | 1-1;<br>1 = MN-AAA not required                                                                  |
| 82      | CDMA-RN-Packet-Data-Inactivity-Timer        | UINT32     | 0-0                                                                                              |
| 83      | CDMA-Forward-PDCH-RC                        | UINT32     | 0-0                                                                                              |
| 84      | CDMA-Forward-DCCH-Mux-Option                | UINT32     | 0-0                                                                                              |

Table C-5 3GPP2 VSAs (continued)

| SubAttr | VSA Name                                                 | Type       | Min-Max Value                                                   |
|---------|----------------------------------------------------------|------------|-----------------------------------------------------------------|
| 85      | CDMA-Reverse-DCCH-Mux-Option                             | UINT3<br>2 | 0-0                                                             |
| 86      | CDMA-Forward-DCCH-RC                                     | UINT3<br>2 | 0-0                                                             |
| 87      | CDMA-Reverse-DCCH-RC                                     | UINT3<br>2 | 0-0                                                             |
| 88      | CDMA-Session-Termination-Capability                      | UINT3<br>2 | 0-0                                                             |
| 89      | CDMA-Allowed-Persistent-TFTs                             | UINT3<br>2 | 0-0                                                             |
| 90      | CDMA-PrePaid-Accounting-Quota                            | String     | 0-253                                                           |
| 91      | CDMA-PrePaid-Accounting-Capability                       | String     | 0-253                                                           |
| 92      | CDMA-MIP-Lifetime                                        | String     | 0-253                                                           |
| 93      | CDMA-Accounting-Stop-Triggered-By-Active-Stop-Indication | ENUM       | 1-1;<br>1 = Accounting report at active/<br>dormant transitions |
| 94      | CDMA-Service-Reference-ID                                | String     | 0-253                                                           |
| 95      | CDMA-DNS-Update-Capability                               | ENUM       | 1-1:<br>1 = HA is capable of dynamic DNS<br>Update              |
| 96      | CDMA-Disconnect-Reason                                   | ENUM       | 1-1:<br>1 = MS Mobility Detection                               |
| 97      | CDMA-Remote-IPv6-Address-Octet-Count                     | String     | 36-253                                                          |
| 98      | CDMA-PrePaid-Tariff-Switching                            | String     | 0-253                                                           |
| 99      | CDMA-Authorization-Parameters                            | String     | 0-253                                                           |
| 100     | CDMA-BCMCS-Flow-ID                                       | String     | 0-253                                                           |
| 101     | CDMA-BCMCS-Capability                                    | String     | 0-253                                                           |
| 102     | CDMA-Common-Session-Info                                 | String     | 0-253                                                           |
| 103     | CDMA-BSN-Session-Info                                    | String     | 0-253                                                           |
| 104     | CDMA-RN-Session-Info                                     | String     | 0-253                                                           |
| 105     | CDMA-Reason-Code                                         | String     | 0-253                                                           |
| 106     | CDMA-Physical-Channel                                    | String     | 0-253                                                           |
| 107     | CDMA-BCMCS-Flow-Transmission-Time                        | String     | 0-253                                                           |
| 108     | CDMA-Subnet                                              | String     | 0-253                                                           |
| 109     | CDMA-Multicast-IP-Address                                | String     | 0-253                                                           |
| 110     | CDMA-Port                                                | String     | 0-253                                                           |
| 111     | CDMA-Auth-Key                                            | String     | 0-253                                                           |



Table C-5 3GPP2 VSAs (continued)

| SubAttr | VSA Name                                                            | Type       | Min-Max Value                         |
|---------|---------------------------------------------------------------------|------------|---------------------------------------|
| 112     | CDMA-TK-Info                                                        | String     | 0-253                                 |
| 113     | CDMA-BAK-ID                                                         | String     | 0-253                                 |
| 114     | CDMA-Reverse-PDCH-RC                                                | UINT3<br>2 | 0-0                                   |
| 115     | CDMA-Acq-Info-Timestamp                                             | UINT3<br>2 | 0-0                                   |
| 116     | CDMA-MEID                                                           | String     | 0-16                                  |
| 117     | CDMA-DNS-Server-IP-Address                                          | String     | 0-22                                  |
| 118     | CDMA-MIP6-Home-Agent-from-BU                                        | String     | 0-18                                  |
| 119     | CDMA-MIP6-CoA                                                       | String     | 0-22                                  |
| 120     | CDMA-MIP6-HoA-Not-Authorized                                        | ENUM       | 1-1;<br>1 = The HoA is not authorized |
| 121     | CDMA-MIP6-Session-Key                                               | String     | 0-253                                 |
| 122     | CDMA-Hot-Line-Accounting-Indication                                 | String     | 0-253                                 |
| 112     | CDMA-Hot-Line-Profile-ID                                            | String     | 0-253                                 |
| 124     | CDMA-Filter-Rule                                                    | String     | 0-253                                 |
| 125     | CDMA-HTTP-Redirection-Rule                                          | String     | 0-253                                 |
| 126     | CDMA-IP-Redirection-Rule                                            | String     | 0-253                                 |
| 127     | CDMA-Hot-Line-Capability                                            | UINT3<br>2 | 0-0                                   |
| 128     | CDMA-MIP6-Home-Link-Prefix                                          | String     | 0-253                                 |
| 129     | CDMA-MIP6-Home-Address                                              | String     | 0-253                                 |
| 130     | CDMA-Maximum-Authorized-Aggregate-Bandwidth-for-Best-Effort-Traffic | UINT3<br>2 | 0-0                                   |
| 131     | CDMA-Authorized-QoS-Profile-IDs-for-the-User                        | String     | 0-253                                 |
| 132     | CDMA-Granted-QoS-Parameters                                         | String     | 0-253                                 |
| 133     | CDMA-Maximum-Per-Flow-Priority-for-the-User                         | UINT3<br>2 | 0-15                                  |
| 134     | CDMA-MIP6-Authenticator                                             | String     | 0-253                                 |
| 135     | CDMA-Source-IPv6-Address                                            | String     | 0-253                                 |
| 136     | CDMA-Program-ID                                                     | String     | 0-253                                 |
| 137     | CDMA-Program-Name                                                   | String     | 0-253                                 |
| 138     | CDMA-MIP6-MAC-Mobility-Data                                         | String     | 0-253                                 |
| 139     | CDMA-Inter-User-Priority                                            | UINT3<br>2 | 0-3                                   |
| 140     | CDMA-MIP6-Home-Agent-Attribute-B                                    | String     | 0-253                                 |
| 141     | CDMA-MIP6-HoA                                                       | String     | 0-253                                 |

Table C-5 3GPP2 VSAs (continued)

| SubAttr | VSA Name                  | Type   | Min-Max Value |
|---------|---------------------------|--------|---------------|
| 142     | CDMA-Carrier-ID           | String | 0-8           |
| 143     | CDMA-GMT-Time-Zone-Offset | String | 0-253         |

## ACC VSAs

Table C-6 lists the ACC VSAs. The vendor ID for ACC VSAs is 5.

Table C-6 ACC VSAs

| SubAttr | VSA Name                    | Type                                                                                                                                                                                                                                                                          | Min-Max Value |
|---------|-----------------------------|-------------------------------------------------------------------------------------------------------------------------------------------------------------------------------------------------------------------------------------------------------------------------------|---------------|
| 1       | Acc-Reason-Code             | ENUM:<br>no reason given/no failure<br>resource shortage<br>protocol error<br>invalid attribute<br>invalid service type<br>invalid framed protocol<br>invalid attribute value<br>invalid user information<br>invalid IP address<br>invalid integer syntax<br>invalid NAS port | 0-56          |
| 1       | Acc-Reason-Code (Continued) | ENUM:<br>requested by user<br>session already open<br>network disconnect<br>service interruption<br>physical port error<br>idle timeout<br>session timeout<br>administrative reset<br>NAS reload or reset<br>NAS error<br>NAS request                                         | 0-56          |
| 1       | Acc-Reason-Code (Continued) | ENUM:<br>undefined reason given<br>too many RADIUS users<br>conflicting attributes<br>port limit exceeded<br>facility not available<br>internal configuration error<br>bad route specification                                                                                | 0-56          |

Table C-6 ACC VSAs (continued)

| SubAttr | VSA Name                    | Type                                                                                                                                                                                                                                                                                                                                                                                            | Min-Max Value |
|---------|-----------------------------|-------------------------------------------------------------------------------------------------------------------------------------------------------------------------------------------------------------------------------------------------------------------------------------------------------------------------------------------------------------------------------------------------|---------------|
| 1       | Acc-Reason-Code (Continued) | Access Partition bind failure<br>security violation<br>request type conflict<br>configuration disallowed<br>missing attribute<br>no authentication server<br>invalid request<br>missing parameter<br>invalid parameter<br>call cleared with cause<br>inopportune config request<br>invalid config parameter<br>missing config parameter<br>incompatible service profile<br>administrative reset | 0-56          |
| 1       | Acc-Reason-Code (Continued) | administrative reload<br>no authentication response<br>port unneeded<br>port preempted<br>port suspended<br>service unavailable<br>callback<br>user error<br>host request<br>no accounting server<br>no accounting response<br>access denied<br>temporary buffer shortage                                                                                                                       | 0-56          |
| 2       | Acc-Ccp-Option              | ENUM:<br>Disabled<br>Enabled                                                                                                                                                                                                                                                                                                                                                                    | 1-2           |
| 3       | Acc-Input-Errors            | UINT32                                                                                                                                                                                                                                                                                                                                                                                          | 0-253         |
| 4       | Acc-Output-Errors           | UINT32                                                                                                                                                                                                                                                                                                                                                                                          | 0-253         |
| 5       | Acc-Access-Partition        | String                                                                                                                                                                                                                                                                                                                                                                                          | 0-253         |
| 6       | Acc-Customer-Id             | String                                                                                                                                                                                                                                                                                                                                                                                          | 0-253         |
| 7       | Acc-Ip-Gateway-Pri          | IPADDR                                                                                                                                                                                                                                                                                                                                                                                          | 0-253         |
| 8       | Acc-Ip-Gateway-Sec          | IPADDR                                                                                                                                                                                                                                                                                                                                                                                          | 0-253         |
| 9       | Acc-Route-Policy            | ENUM :<br>Funnel<br>Direct                                                                                                                                                                                                                                                                                                                                                                      | 1-2           |
| 10      | Acc-ML-MLX-Admin-State      | ENUM:<br>Enabled<br>Disabled                                                                                                                                                                                                                                                                                                                                                                    | 1-2           |
| 11      | Acc-ML-Call-Threshold       | UINT32                                                                                                                                                                                                                                                                                                                                                                                          | 0-253         |

Table C-6 ACC VSAs (continued)

| SubAttr | VSA Name                          | Type                                                                                                                                                                                                                                                                                                                                                                  | Min-Max Value |
|---------|-----------------------------------|-----------------------------------------------------------------------------------------------------------------------------------------------------------------------------------------------------------------------------------------------------------------------------------------------------------------------------------------------------------------------|---------------|
| 12      | Acc-ML-Clear-Threshold            | UINT32                                                                                                                                                                                                                                                                                                                                                                | 0-253         |
| 13      | Acc-ML-Damping-Factor             | UINT32                                                                                                                                                                                                                                                                                                                                                                | 0-253         |
| 14      | Acc-Tunnel-Secret                 | String                                                                                                                                                                                                                                                                                                                                                                | 0-253         |
| 15      | Acc-Clearing-Cause                | ENUM:<br>cause unspecified<br>unassigned number<br>invalid information element c<br>message incompatible with sta<br>recovery on timer expiration<br>mandatory information element<br>protocol error<br>interworking<br>normal clearing<br>user busy<br>no user responding<br>user alerted no answer                                                                  | 0-127         |
| 15      | Acc-Clearing-Cause<br>(Continued) | ENUM:<br>no route to transit network<br>call rejected<br>number changed<br>non selected user clearing<br>destination out of order<br>invalid or incomplete number<br>facility rejected<br>no route to destination<br>response to status inquiry<br>normal unspecified cause<br>no circuit or channel availab<br>network out of order                                  | 0-127         |
| 15      | Acc-Clearing-Cause<br>(Continued) | ENUM:<br>temporary failure<br>switching equipment congestio<br>access information discarded<br>circuit or channel unavailabl<br>circuit or channel preempted<br>resources unavailable<br>quality of service unavailabl<br>facility not subscribed<br>outgoing calls barred<br>incoming calls barred<br>bearer capability unauthorize<br>bearer capability not availab | 0-127         |

Table C-6 ACC VSAs (continued)

| SubAttr | VSA Name                          | Type                                                                                                                                                                                                                                                                                                                                                                                    | Min-Max Value |
|---------|-----------------------------------|-----------------------------------------------------------------------------------------------------------------------------------------------------------------------------------------------------------------------------------------------------------------------------------------------------------------------------------------------------------------------------------------|---------------|
| 15      | Acc-Clearing-Cause<br>(Continued) | ENUM:<br>channel unacceptable<br>service not available<br>bearer capability not impleme<br>channel type not implemented<br>facility not implemented<br>call awarded being delivered<br>restricted digital informatio<br>service not implemented<br>invalid call reference<br>identified channel does not e<br>call identity does not exist<br>call identity in use<br>no call suspended | 0-127         |
| 15      | Acc-Clearing-Cause<br>(Continued) | ENUM:<br>suspended call cleared<br>incompatible destination<br>invalid transit network selec<br>invalid message<br>mandatory information element<br>message not implemented<br>inopportune message<br>information element not imple                                                                                                                                                     | 0-127         |
| 16      | Acc-Clearing-Location             | ENUM:<br>local or remote user<br>private network serving local<br>beyond interworking point<br>public network serving local<br>transit network<br>private network serving remot<br>public network serving remote<br>international network                                                                                                                                               | 0-10          |
| 17      | Acc-Service-Profile               | String                                                                                                                                                                                                                                                                                                                                                                                  | 0-253         |
| 18      | Acc-Request-Type                  | ENUM:<br>Ring Indication<br>Dial Request<br>User Authentication<br>Tunnel Authentication<br>User Accounting<br>Tunnel Accounting                                                                                                                                                                                                                                                        | 1-6           |
| 19      | Acc-Framed-Bridge                 | ENUM :<br>Disabled<br>Enabled                                                                                                                                                                                                                                                                                                                                                           | 0-1           |
| 20      | Acc-Vpsm-Oversubscribed           | ENUM :<br>False<br>True                                                                                                                                                                                                                                                                                                                                                                 | 1-2           |

Table C-6 ACC VSAs (continued)

| SubAttr | VSA Name                  | Type                                                                                                    | Min-Max Value |
|---------|---------------------------|---------------------------------------------------------------------------------------------------------|---------------|
| 21      | Acc-Acct-On-Off-Reason    | ENUM :<br>NAS Reset<br>NAS Reload<br>Configuration Reset<br>Configuration Reload<br>Enabled<br>Disabled | 0-5           |
| 22      | Acc-Tunnel-Port           | UINT32                                                                                                  | 0-253         |
| 12      | Acc-Dns-Server-Pri        | IPADDR                                                                                                  | 0-253         |
| 24      | Acc-Dns-Server-Sec        | IPADDR                                                                                                  | 0-253         |
| 26      | Acc-Nbns-Server-Sec       | IPADDR                                                                                                  | 0-253         |
| 27      | Acc-Dial-Port-Index       |                                                                                                         |               |
| 28      | Acc-Ip-Compression        | ENUM:<br>Disabled<br>Enabled                                                                            | 0-1           |
| 29      | Acc-Ipx-Compression       | ENUM:<br>Disabled<br>Enabled                                                                            | 0-1           |
| 30      | Acc-Connect-Tx-Speed      | UINT32                                                                                                  | 0-253         |
| 31      | Acc-Connect-Rx-Speed      | UINT32                                                                                                  | 0-253         |
| 32      | Acc-Modem-Modulation-Type | String                                                                                                  | 0-253         |
| 33      | Acc-Modem-Error-Protocol  | String                                                                                                  | 0-253         |
| 34      | Acc-Callback-Delay        | UINT32                                                                                                  | 0-253         |
| 35      | Acc-Callback-Num-Valid    | String                                                                                                  | 0-253         |
| 36      | Acc-Callback-Mode         | ENUM:<br>User-Auth<br>User-Specified-E-164<br>CBCP-Callback<br>CLI-Callback                             | 0-7           |
| 37      | Acc-Callback-CBCP-Type    | ENUM:<br>CBCP-None<br>CBCP-User-Specified<br>CBCP-Pre-Specified                                         | 1-3           |
| 38      | Acc-Dialout-Auth-Mode     | ENUM:<br>PAP<br>CHAP<br>CHAP-PAP<br>NONE                                                                | 1-4           |
| 39      | Acc-Dialout-Auth-Password | String                                                                                                  | 0-253         |
| 40      | Acc-Dialout-Auth-UserName | String                                                                                                  | 0-253         |

**Table C-6 ACC VSAs (continued)**

| SubAttr | VSA Name              | Type                                                                                                                                                                                                    | Min-Max Value |
|---------|-----------------------|---------------------------------------------------------------------------------------------------------------------------------------------------------------------------------------------------------|---------------|
| 42      | Acc-Access-Community  | ENUM:<br>PUBLIC<br>NETMAN                                                                                                                                                                               | 1-2           |
| 43      | Acc-Vpsm-Reject-Cause | ENUM:<br>No-Access-Partition<br>Access-Partition-Disabled<br>Partition-Portlimit-Exceeded<br>License-Portlimit-Exceeded<br>Home-Server-Down<br>Rejected-By-Home-Server<br>NAS-Administratively-Disabled | 1-7           |
| 44      | Acc-Ace-Token         | String                                                                                                                                                                                                  | 0-253         |
| 45      | Acc-Ace-Token-Ttl     | UINT                                                                                                                                                                                                    | 0-253         |
| 46      | Acc-Ip-Pool-Name      | String                                                                                                                                                                                                  | 0-253         |
| 47      | Acc-Igmp-Admin-State  | ENUM :<br>Enabled<br>Disabled                                                                                                                                                                           | 1-2           |
| 48      | Acc-Igmp-Version      | ENUM :<br>V1<br>V2                                                                                                                                                                                      | 1-2           |

## Altiga VSAs

Table C-7 lists the Altiga VSAs. The vendor ID for Altiga VSAs is 3076.

**Table C-7 Altiga VSAs**

| SubAttr | VSA Name                                     | Type       | Min-Max Value |
|---------|----------------------------------------------|------------|---------------|
| 1       | Altiga-General-Access-Hours                  | String     | 0-253         |
| 2       | Altiga-General-Simultaneous-Logic            | UINT32     | 0-253         |
| 3       | Altiga-General-Minimum-Password-Length       | UINT32     | 0-253         |
| 4       | Altiga-General-All-Alphabetic-Only-Passwords | ENUM       | 0-1           |
| 5       | Altiga-General-Primary-DNS                   | IP Address | 0-253         |
| 6       | Altiga-General-Secondary-DNS                 | IP Address | 0-253         |
| 8       | Altiga-General-Secondary-WINS                | IP Address | 0-253         |
| 9       | Altiga-General-SEP-Card-Assignment           | UINT32     | 0-253         |
| 10      | Altiga-General-Priority-On-SEP               | UINT32     | 0-253         |
| 11      | Altiga-General-Tunneling-Protoco             | UNIT32     | 0-253         |
| 12      | Altiga-IPSec-Security-Associatio             | String     | 0-253         |

Table C-7 Altiga VSAs (continued)

| SubAttr | VSA Name                                        | Type                                                                       | Min-Max Value |
|---------|-------------------------------------------------|----------------------------------------------------------------------------|---------------|
| 13      | Altiga-IPSec-Authentication                     | ENUM:<br>None<br>RADIUS<br>LDAP<br>NT Domain<br>SDI<br>Internal            | 0-5           |
| 15      | Altiga-IPSec-Banner                             | String                                                                     | 0-253         |
| 16      | Altiga-IPSec-Allow-Password-Storage-On-Client   | ENUM:<br>False<br>True                                                     | 0-1           |
| 17      | Altiga-PPTP-L2TP-Use-Client-Specified-Addresses | ENUM:<br>False<br>True                                                     | 0-1           |
| 18      | Altiga-PPTP-Minimal-Authentication-Protocol     | UINT32                                                                     | 0-253         |
| 19      | Altiga-L2TP-Minimal-Authentication              | UINT32                                                                     | 0-253         |
| 20      | Altiga-PPTP-Encryption                          | UINT32                                                                     | 0-253         |
| 21      | Altiga-L2TP-Encryption                          | UINT32                                                                     | 0-253         |
| 22      | Altiga-Argument-Authentication-Server-Type      | ENUM:<br>First Active<br>Server<br>RADIUS<br>LDAP<br>NT<br>SDI<br>Internal | 0-5           |
| 12      | Altiga-Argument-Authentication-Server-Password  | String                                                                     | 0-253         |
| 24      | Altiga-Argument-Request-Authenticator-Vector    | String                                                                     | 0-253         |
| 25      | Altiga-IPSec-LTL-Keepalives                     | ENUM:<br>False<br>True                                                     | 0-1           |
| 26      | Altiga-Argument-IPSec-Group-Name                | String                                                                     | 0-253         |
| 27      | Altiga-IPSec-Split-Tunneling                    | String                                                                     | 0-253         |
| 28      | Altiga-IPSec-Default-Domain                     | String                                                                     | 0-253         |
| 28      | Altiga-IPSec-Secondary-Domain-List              | String                                                                     | 0-253         |
| 30      | Altiga-IPSec-Tunnel-Type                        | ENUM:<br>LAN to<br>LAN<br>Remote<br>Access                                 | 1-2           |



Table C-7 Altiga VSAs (continued)

| SubAttr | VSA Name                                       | Type                   | Min-Max Value |
|---------|------------------------------------------------|------------------------|---------------|
| 31      | Altiga-IPSec-Mode-Configuration                | ENUM:<br>False<br>True | 0-1           |
| 32      | Altiga-Argument-Authentication-Server-Priority | UINT32                 | 0-253         |
| 33      | Altiga-IPSec-Group-Lock-Of-User                | ENUM:<br>False<br>True | 0-1           |
| 34      | Altiga-IPSec-IPSec-Over-UDP                    | ENUM:<br>False<br>True | 0-1           |
| 35      | Altiga-IPSec-UDP-Port-For-IPSec                | UINT32                 | 0-253         |
| 128     | Altiga-Partitioning-Primary-DHCP               |                        |               |
| 129     | Altiga-Partitioning-Secondary-DHCP             | IP Address             | 0-253         |
| 131     | Altiga-Partitioning-Premise-Rout               | IP Address             | 0-253         |
| 132     | Altiga-Partitioning-Partition-Max-Sessions     | String                 | 0-253         |
| 133     | Altiga-Partitioning-Mobile-IP-Key              | String                 | 0-253         |
| 134     | Altiga-Partitioning-Mobile-IP-Address          | IP Address             | 0-253         |
| 135     | Altiga-Partitioning-Mobile-IP-SPI              | IP Address             | 0-253         |
| 136     | Altiga-Partitioning-Strip-Realm                | ENUM:<br>False<br>True | 0-1           |
| 137     | Altiga-Partitioning-Group-ID                   | UINT32                 | 0-253         |
| 250     | Altiga-Group-Name                              | String                 | 0-253         |

## Ascend VSAs

Table C-8 lists the Ascend VSAs. The vendor ID for Ascend VSAs is 529.

**Table C-8** Ascend VSAs

| SubAttr | VSA Name                       | Type                                                                                               | Min-Max Value |
|---------|--------------------------------|----------------------------------------------------------------------------------------------------|---------------|
| 17      | Ascend-Change-Password         | String                                                                                             | 0 - 253       |
| 18      | Ascend-Session-Type            | ENUM:<br>Unused<br>Unknown<br>G711-Ulaw<br>G711-Alaw<br>G712<br>G729<br>G712-64KPS<br>G728<br>RT24 | 0 - 8         |
| 19      | Ascend-H312-Gatekeeper         | IP Address                                                                                         | 0 - 253       |
| 21      | Ascend-H312-Conference-ID      | String                                                                                             | 0-253         |
| 22      | Ascend-H312-Destination-NAS-ID | IP Address                                                                                         | 0-65535       |
| 12      | Ascend-H312-Dialed-Time        | UINT32                                                                                             | 0-253         |
| 24      | Ascend-H312-Dialed-Number      | String                                                                                             | 0-253         |
| 25      | Ascend-Inter-Arrival-Jitter    | UINT32                                                                                             | 0-253         |
| 26      | Ascend-Dropped-Octets          | UINT32                                                                                             | 0-253         |
| 27      | Ascend-Dropped-Packets         | UINT32                                                                                             | 0-253         |
| 48      | Ascend-Call-Direction          | ENUM:<br>Incoming<br>Outgoing                                                                      | 0-1           |

Table C-8 Ascend VSAs (continued)

| SubAttr | VSA Name                    | Type                                                                                             | Min-Max Value                                                                                                                                                                                                                                         |
|---------|-----------------------------|--------------------------------------------------------------------------------------------------|-------------------------------------------------------------------------------------------------------------------------------------------------------------------------------------------------------------------------------------------------------|
| 49      | Ascend-Service-Type         | ENUM                                                                                             | 0 - 12;<br>NotUsed<br>None<br>EuUi<br>Telnet<br>TelnetBin<br>RawTcp<br>TermServer<br>MP<br>VirtualConn<br>X25DChan<br>PseuTun<br>PPP<br>IpFax<br>Other<br>ATM<br>HdlcNrm<br>VoIp<br>Visa2<br>PPP<br>Slip<br>MPP<br>X25<br>Combine<br>t<br>FR<br>EuRaw |
| 68      | Ascend-Tunnel-ID            | String                                                                                           | 0 - 253                                                                                                                                                                                                                                               |
| 126     | Ascend-Route-Preference     | ENUM:<br>Interface,<br>OSPF-Internal<br>,<br>RIP,<br>Down-WAN,<br>OSPF-ASE,<br>Infinite,<br>ICMP | 0-225                                                                                                                                                                                                                                                 |
| 132     | Ascend-Client-Gateway       | IP Address                                                                                       | 0 - 253                                                                                                                                                                                                                                               |
| 144     | Ascend-Assign-IP-Client     | IP Address                                                                                       | 0-0                                                                                                                                                                                                                                                   |
| 145     | Ascend-Assign-IP-Server     | IP Address                                                                                       | 0-0                                                                                                                                                                                                                                                   |
| 152     | Ascend-Multicast-Rate-Limit | UINT32                                                                                           | 0-65535                                                                                                                                                                                                                                               |
| 162     | Ascend-FR-DCE-N392          | UINT32                                                                                           | 0-65535                                                                                                                                                                                                                                               |

Table C-8 Ascend VSAs (continued)

| SubAttr | VSA Name                   | Type                                                               | Min-Max Value |
|---------|----------------------------|--------------------------------------------------------------------|---------------|
| 163     | Ascend-FR-DTE-N392         | UINT32                                                             | 0-65535       |
| 164     | Ascend-FR-DCE-N393         | UINT32                                                             | 0-65535       |
| 165     | Ascend-FR-DTE-N393         | UINT32                                                             | 0-65535       |
| 166     | Ascend-FR-T391             | UINT32                                                             | 0-65535       |
| 167     | Ascend-FR-T392             | UINT32                                                             | 0-65535       |
| 168     | Ascend-Bridge-Address      | UINT32                                                             | 1-253         |
| 169     | Ascend-TS-Idle-Limit       | UINT32                                                             | 0-65535       |
| 170     | Ascend-TS-Idle-Mode        | ENUM;<br>TS-Idle-None<br>TS-Idle-Input<br>TS-Idle-Input-<br>Output | 0-2           |
| 171     | Ascend-DBA-Monitor         | ENUM;<br>Transmit<br>Transmit-Rece<br>ive<br>None                  | 0-2           |
| 172     | Ascend-Base-Channel-Count  | UINT32                                                             | 0-65535       |
| 173     | Ascend-Minimum-Channels    | UINT32                                                             | 0-65535       |
| 174     | Ascend-IPX-Route           | String                                                             | 1-253         |
| 175     | Ascend-FT1-Caller          | ENUM;<br>FT1-No<br>FT1-Yes                                         | 0-1           |
| 176     | Ascend-Backup              | String                                                             | 1-253         |
| 177     | Ascend-Call-Type           | ENUM;<br>Nailed<br>Nailed/MPP<br>Perm/Switche<br>d                 | 0-2           |
| 178     | Ascend-Group               | String                                                             | 1-253         |
| 179     | Ascend-FR-DLCI             | UINT32                                                             | 0-65535       |
| 180     | Ascend-FR-Profile-Name     | String                                                             | 1-253         |
| 181     | Ascend-Ara-PW              | String                                                             | 1-253         |
| 182     | Ascend-IPX-Node-Address    | String                                                             | 1-253         |
| 183     | Ascend-Home-Agent-IP-Addr  | IP Address                                                         | 0-0           |
| 184     | Ascend-Home-Agent-Password | String                                                             | 1-253         |
| 185     | Ascend-Home-Network-Name   | String                                                             | 1-253         |
| 186     | Ascend-Home-Agent-UDP-Port | UINT32                                                             | 0-65535       |
| 187     | Ascend-Multilink-ID        | UINT32                                                             | 0-65535       |

**Table C-8 Ascend VSAs (continued)**

| <b>SubAttr</b> | <b>VSA Name</b>           | <b>Type</b> | <b>Min-Max Value</b> |
|----------------|---------------------------|-------------|----------------------|
| 188            | Ascend-Num-In-Multilink   | UINT32      | 0-65535              |
| 189            | Ascend-First-Dest         | IP Address  | 0-0                  |
| 190            | Ascend-Pre-Input-Octets   | UINT32      | 0-65535              |
| 191            | Ascend-Pre-Output-Octets  | UINT32      | 0-65535              |
| 192            | Ascend-Pre-Input-Packets  | UINT32      | 0-65535              |
| 193            | Ascend-Pre-Output-Packets | UINT32      | 0-65535              |
| 194            | Ascend-Maximum-Time       | UINT32      | 0-65535              |

Table C-8 Ascend VSAs (continued)

| SubAttr | VSA Name                                  | Type                                                                                                                                                                                                                                                                                                                                                                                                                                                                                                                      | Min-Max Value |
|---------|-------------------------------------------|---------------------------------------------------------------------------------------------------------------------------------------------------------------------------------------------------------------------------------------------------------------------------------------------------------------------------------------------------------------------------------------------------------------------------------------------------------------------------------------------------------------------------|---------------|
| 195     | vAscend-Pre-Output-Packets<br>(continued) | ENUM:<br>No-Reason,<br>Not-Applicable,<br>Modem-No-DCD,<br>Session-Timeout,<br>Invalid-Incoming-User,<br>Disconnect-Due-To-Callback,<br>DCD-Detected-Then-Inactive,<br>Modem-Invalid-Result-Codes,<br>Protocol-Disabled-Or-Unsupported,<br>Disconnect-Request-By-RADIUS,<br>Disconnect-Request-By-Local-Admin,<br>V110-Timeout-Or-Sync-Retry-Ex,<br>PPP-Auth-Timeout-Exceeded,<br>User-Executed-Do-Hangup,<br>Remote-End-Hung-Up,<br>Resource-Has-Been-Quiesced,<br>Max-Call-Duration-Reached,<br>Unknown,<br>(continued) | 0-195         |

Table C-8 Ascend VSAs (continued)

| SubAttr | VSA Name                   | Type                                                                                                                                                                                                                                                                                                                                                                                                                                                                                                       | Min-Max Value |
|---------|----------------------------|------------------------------------------------------------------------------------------------------------------------------------------------------------------------------------------------------------------------------------------------------------------------------------------------------------------------------------------------------------------------------------------------------------------------------------------------------------------------------------------------------------|---------------|
| 195     | vAscend-Pre-Output-Packets | ENUM:<br>TermSrv-User-Quit,<br>TermSrv-Idle-Timeout,<br>TermSrv-Exit-Telnet,<br>TermSrv-No-I Paddr,<br>TermSrv-Exit-Raw-TCP,<br>TermSrv-Exit-Login-Failed,<br>TermSrv-Exit-Raw-TCP-Disabled,<br>TermSrv-CTRL-C-In-Login,<br>TermSrv-Destroyed,<br>TermSrv-User-Closed-VConn,<br>,<br>Call-Disconnected,<br>TermSrv-VConn-Destroyed,<br>TermSrv-Exit-Rlogin,<br>TermSrv-Bad-Rlogin-Option,<br>,<br>TermSrv-Not-Enough-Resources,<br>MPP-No-NUL L-Msg-Timeout,<br>CLID-Authentication-Failed,<br>(continued) | 0-195         |

Table C-8 Ascend VSAs (continued)

| SubAttr | VSA Name                   | Type                                                                                                                                                                                                                                                                                                                                                    | Min-Max Value |
|---------|----------------------------|---------------------------------------------------------------------------------------------------------------------------------------------------------------------------------------------------------------------------------------------------------------------------------------------------------------------------------------------------------|---------------|
| 195     | vAscend-Pre-Output-Packets | ENUM:<br>PPP-LCP-Tim<br>eout,<br>PPP-LCP-Neg<br>otiation-Failed,<br>PPP-PAP-Aut<br>h-Failed,<br>PPP-CHAP-A<br>uth-Failed,<br>PPP-Rmt-Auth<br>-Failed,<br>PPP-Rcv-Ter<br>minate-Req,<br>PPP-Rcv-Clos<br>e-Event,<br>PPP-No-NCPs<br>-Open,<br>PPP-MP-Bund<br>le-Unknown,.<br>PPP-LCP-Clos<br>e-MP-Add-Fai<br>l,<br>CLID-RADIU<br>S-Timeout<br>(continued) | 0-195         |



Table C-8 Ascend VSAs (continued)

| SubAttr | VSA Name                                  | Type                                                                                                                                                                                                                                                                                                              | Min-Max Value |
|---------|-------------------------------------------|-------------------------------------------------------------------------------------------------------------------------------------------------------------------------------------------------------------------------------------------------------------------------------------------------------------------|---------------|
| 195     | vAscend-Pre-Output-Packets<br>(continued) | Out-Of-Resources,<br>Invalid-IP-Address,<br>Hostname-Resolution-Failed,<br>Bad-Or-Missing-Port-Number, Host-Reset,<br>Connection-Refused,<br>Connection-Timeout,<br>Connection-Closed,<br>Network-Unreachable,<br>Host-Unreachable,<br>Network-Unreachable-Admin,<br>Host-Unreachable-Admin,<br>Port-Unreachable, |               |

Table C-8 Ascend VSAs (continued)

| SubAttr | VSA Name                | Type                                                                                                                                                                                                                                                                                                                                                                                                                                 | Min-Max Value |
|---------|-------------------------|--------------------------------------------------------------------------------------------------------------------------------------------------------------------------------------------------------------------------------------------------------------------------------------------------------------------------------------------------------------------------------------------------------------------------------------|---------------|
| 196     | Ascend-Connect-Progress | ENUM:<br>No-Progress,<br>unknown1,<br>Call-Up,<br>unknown2,<br>Modem-Up,<br>Modem-Await<br>ing-DCD,<br>Modem-Await<br>ing-Codes,<br>TermSrv-Start<br>ed,<br>TermSrv-Raw-<br>TCP-Started,<br>TermSrv-Teln<br>et-Started,<br>TermSrv-Raw-<br>TCP-Connecte<br>d,<br>TermSrv-Teln<br>et-Connected,<br>TermSrv-Rlog<br>in-Started,<br>TermSrv-Rlog<br>in-Connected,<br>TermSrv-Auth<br>entication-Beg<br>in,<br>Modem-Outdi<br>al-Call-Up | 0-94          |

Table C-8 Ascend VSAs (continued)

| SubAttr | VSA Name                | Type                                                                                                                                                                                                                                                                                                                                                                                                                                                                                                                         | Min-Max Value |
|---------|-------------------------|------------------------------------------------------------------------------------------------------------------------------------------------------------------------------------------------------------------------------------------------------------------------------------------------------------------------------------------------------------------------------------------------------------------------------------------------------------------------------------------------------------------------------|---------------|
| 196     | Ascend-Connect-Progress | ENUM:<br>LAN-Session-Up,<br>LCP-Opening,<br>CCP-Opening,<br>IPNCP-Opening,<br>NCP-Opening,<br>LCP-Opened,<br>CCP-Opened,<br>IPNCP-Opened,<br>BNCP-Opened,<br>LCP-State-Initial,<br>LCP-State-Starting,<br>LCP-State-Closed,<br>LCP-State-Stopped,<br>BACP-Opened,<br>LCP-State-Stopping,<br>LCP-State-Request-Sent,<br>LCP-State-Ack-Received,<br>LCP-State-Ack-Sent,<br>IPXNCP-Opened,<br>ATNCP-Opened,<br>BACP-Opening,<br>V110-Up,<br>V110-State-Opened,<br>V110-State-Carrier,<br>V110-State-Reset,<br>V110-State-Closed | 0-94          |
| 197     | Ascend-Data-Rate        | UINT32                                                                                                                                                                                                                                                                                                                                                                                                                                                                                                                       | 0-65535       |

Table C-8 Ascend VSAs (continued)

| SubAttr | VSA Name                | Type                                                                                                                                                                                                                                                                                                                     | Min-Max Value |
|---------|-------------------------|--------------------------------------------------------------------------------------------------------------------------------------------------------------------------------------------------------------------------------------------------------------------------------------------------------------------------|---------------|
| 198     | Ascend-PreSession-Time  | UINT32                                                                                                                                                                                                                                                                                                                   | 0-65535       |
| 199     | Ascend-Token-Idle       | UINT32                                                                                                                                                                                                                                                                                                                   | 0-65535       |
| 200     |                         | ENUM:<br>Tok-Imm-No,<br>Tok-Imm-Yes                                                                                                                                                                                                                                                                                      | 0-1           |
| 201     | Ascend-Require-Auth     | ENUM:<br>Not-Require-Auth<br>Require-Auth<br>Pap-Only<br>Pap-Only<br>Pap-Login-Only<br>Pap-Framed-Only<br>Pap-Outbound-Only<br>CHAP-Only<br>CHAP-Only<br>CHAP-Login-Only<br>CHAP-Framed-Only<br>CHAP-Outbound-Only<br>MS-CHAP-Only<br>MS-CHAP-Only<br>MS-CHAP-Login-Only<br>MS-CHAP-Framed-Only<br>MS-CHAP-Outbound-Only | 0-55          |
| 210     | Ascend-PPP-VJ-Slot-Comp | ENUM:<br>VJ-Slot-Comp-No                                                                                                                                                                                                                                                                                                 | 1-1           |
| 211     | Ascend-PPP-VJ-1172      | ENUM:<br>PPP-VJ-1172                                                                                                                                                                                                                                                                                                     | 1-1           |
| 212     | Ascend-PPP-Async-Map    | UINT32                                                                                                                                                                                                                                                                                                                   | 0-65535       |
| 213     | Ascend-Third-Prompt     | String                                                                                                                                                                                                                                                                                                                   | 1-253         |
| 214     | Ascend-Send-Secret      | String                                                                                                                                                                                                                                                                                                                   | 1-253         |
| 215     | Ascend-Receive-Secret   | String                                                                                                                                                                                                                                                                                                                   | 1-253         |

Table C-8 Ascend VSAs (continued)

| SubAttr | VSA Name                  | Type                                                                                               | Min-Max Value |
|---------|---------------------------|----------------------------------------------------------------------------------------------------|---------------|
| 216     | Ascend-IPX-Peer-Mode      | ENUM:<br>IPX-Peer-Router,<br>IPX-Peer-Dialin                                                       | 1-1           |
| 217     | Ascend-IP-Pool-Definition | String                                                                                             | 1-253         |
| 218     | Ascend-Assign-IP-Pool     | UINT32                                                                                             | 0-65535       |
| 219     | Ascend-FR-Direct          | ENUM:<br>FR-Direct-No,<br>FR-Direct-Yes                                                            | 1-1           |
| 220     | Ascend-FR-Direct-Profile  | String                                                                                             | 1-253         |
| 221     | Ascend-FR-Direct-DLCI     | UINT32                                                                                             | 0-65535       |
| 222     | Ascend-Handle-IPX         | ENUM:<br>Handle-IPX-None,<br>Handle-IPX-Client,<br>Handle-IPX-Server                               | 0-2           |
| 212     | Ascend-Netware-timeout    | UINT32                                                                                             | 0-65535       |
| 224     | Ascend-IPX-Alias          | UINT32                                                                                             | 0-65535       |
| 225     | Ascend-Metric             | UINT32                                                                                             | 0-65535       |
| 226     | Ascend-PRI-Number-Type    | ENUM:<br>Unknown-Number,<br>Intl-Number,<br>National-Number,<br>Local-Number<br>Abbrev-Number      | 0-5           |
| 227     | Ascend-Dial-Number        | String                                                                                             | 1-253         |
| 228     | Ascend-Route-IP           | ENUM:<br>Unknown-Number,<br>Intl-Number,<br>National-Number,<br>Local-Number<br>,<br>Abbrev-Number | 0-5           |

Table C-8 Ascend VSAs (continued)

| SubAttr | VSA Name                  | Type                                                                                            | Min-Max Value |
|---------|---------------------------|-------------------------------------------------------------------------------------------------|---------------|
| 229     | Ascend-Route-IPX          | ENUM:<br>Route-IPX-No<br>Route-IPX-Yes                                                          | 0-1           |
| 120     | Ascend-Bridge             | ENUM:<br>Bridge-No,<br>Bridge-Yes                                                               | 0-1           |
| 121     | Ascend-Send-Auth          | ENUM:<br>Send-Auth-None,<br>Send-Auth-PAP,<br>Send-Auth-CHAP                                    | 0-2           |
| 122     | Ascend-Send-Passwd        | String                                                                                          | 1-253         |
| 123     | Ascend-Link-Compression   | ENUM:<br>Link-Comp-None,<br>Link-Comp-Stack,<br>Link-Comp-Stack-Draft-9,<br>Link-Comp-MSS-Stack | 0-3           |
| 124     | Ascend-Target-Util        | UINT32                                                                                          | 0-65535       |
| 125     | Ascend-Maximum-Channels   | UINT32                                                                                          | 0-65535       |
| 126     | Ascend-Inc-Channel-Count  | UINT32                                                                                          | 0-65535       |
| 127     | Ascend-Dec-Channel-Count  | UINT32                                                                                          | 0-65535       |
| 128     | Ascend-Seconds-Of-History | UINT32                                                                                          | 0-65535       |
| 129     | Ascend-History-Weigh-Type | ENUM:<br>History-Constant,<br>History-Linear,<br>History-Quadratic                              | 0-2           |
| 240     | Ascend-Add-Seconds        | UINT32                                                                                          | 0-65535       |
| 241     | Ascend-Remove-Seconds     | UINT32                                                                                          | 0-65535       |
| 242     | Ascend-Data-Filter        | String                                                                                          | 1-253         |
| 243     | Ascend-Call-Filter        | String                                                                                          | 1-253         |
| 244     | Ascend-Idle-Limit         | UINT32                                                                                          | 0-65535       |
| 245     | Ascend-Idle-Limit         | UINT32                                                                                          | 0-65535       |

**Table C-8** Ascend VSAs (continued)

| <b>SubAttr</b> | <b>VSA Name</b> | <b>Type</b>                           | <b>Min-Max Value</b> |
|----------------|-----------------|---------------------------------------|----------------------|
| 246            | Ascend-Callback | ENUM:<br>Callback-No,<br>Callback-Yes | 0-1                  |

Table C-8 Ascend VSAs (continued)

| SubAttr | VSA Name        | Type                                                                                                                                                                                                                                                                                                                                                                                                                                                                                                                                            | Min-Max Value |
|---------|-----------------|-------------------------------------------------------------------------------------------------------------------------------------------------------------------------------------------------------------------------------------------------------------------------------------------------------------------------------------------------------------------------------------------------------------------------------------------------------------------------------------------------------------------------------------------------|---------------|
| 247     | Ascend-Data-Svc | ENUM:<br>Switched-Voice-Bearer,<br>Switched-56KR,<br>Switched-192K,<br>Switched-256K,<br>Switched-320K,<br>Switched-384K-MR,<br>Switched-448K,<br>Switched-512K,<br>Switched-566K,<br>Switched-640K,<br>Switched-704K,<br>Switched-768K,<br>Switched-64K,<br>Switched-832K,<br>Switched-896K,<br>Switched-960K,<br>Switched-1024K,<br>Switched-1088K,<br>Switched-1152K,<br>Switched-1216K,<br>Switched-1280K,<br>Switched-1344K,<br>Switched-1408K,<br>Switched-64KR,<br>Switched-1472K,<br>Switched-1600K,<br>Switched-1664K,<br>Switched-172 | 0-43          |



**Table C-8 Ascend VSAs (continued)**

| SubAttr | VSA Name                | Type                                  | Min-Max Value |
|---------|-------------------------|---------------------------------------|---------------|
| 248     | Ascend-Force-56         | ENUM:<br>Force-56-No,<br>Force-56-Yes | 0-1           |
| 249     | Ascend-Billing-Number   | String                                | 1-253         |
| 250     | Ascend-Call-By-Call     | UINT32                                | 0-65535       |
| 251     | Ascend-Transit-Number   | String                                | 1-253         |
| 252     | Ascend-Host-Info        | String                                | 1-253         |
| 253     | Ascend-PPP-Address      | IP Address                            | 0-0           |
| 254     | Ascend-MPP-Idle-Percent | UINT32                                | 0-65535       |

## Bay Networks VSAs

[Table C-9](#) Lists the Bay Networks VSAs. The vendor ID for Bay Networks VSAs is 1584.

**Table C-9 Bay Networks VSAs**

| SubAttr | VSA Name                 | Type   | Min-Max Value |
|---------|--------------------------|--------|---------------|
| 28      | Annex-Filter             | String | 1-253         |
| 29      | Annex-CLI-Command        | String | 1-253         |
| 30      | Annex-CLI-Filter         | String | 1-253         |
| 31      | Annex-Host-Restrict      | String | 1-253         |
| 32      | Annex-Host-Allow         | String | 1-253         |
| 33      | Annex-Product-Name       | String | 1-253         |
| 34      | Annex-SW-Version         | String | 1-253         |
| 35      | Annex-Local-IP-Address   | IPADDR | 1-253         |
| 36      | Annex-Callback-Portlist  | UINT32 | 0-0           |
| 44      | Annex-System-Disc-Reason | UINT32 | 0-0           |
| 45      | Annex-Modem-Disc-Reason  | UINT32 | 0-0           |
| 46      | Annex-Disconnect-Reason  | UINT32 | 0-0           |
| 50      | Annex-Transmit-Speed     | UINT32 | 0-0           |
| 51      | Annex-Receive-Speed      | UINT32 | 0-0           |

## Cabletron VSAs

Table C-10 lists the Cabletron VSAs. The vendor ID for Cabletron VSAs is 52.

**Table C-10** Cabletron VSAs

| SubAttr | VSA Name                       | Type                                                        | Min-Max Value |
|---------|--------------------------------|-------------------------------------------------------------|---------------|
| 192     | Cabletron-Framed-Data-Rate     | ENUM:<br>Rate-56KB<br>Rate-64KB<br>Rate-112KB<br>Rate-128KB | 0-4           |
| 193     | Cabletron-Phone-Number         | String                                                      | 0-253         |
| 194     | Cabletron-Caller-Id            | String                                                      | 0-253         |
| 196     | Cabletron-Connection-Reference | UINT32                                                      | 0-253         |
| 198     | Cabletron-Initial-Rate         | UINT32                                                      | 0-253         |
| 199     | Cabletron-Maximum-Rate         | UINT32                                                      | 0-253         |
| 192     | Cabletron-Framed-Data-Rate     | Enum:<br>Rate-56KB<br>Rate-64KB<br>Rate-112KB<br>Rate-128KB | 192           |

## Cisco Prime Access Registrar Internal VSAs

Table C-11 lists the Cisco Prime AR Internal VSAs. The vendor ID for Cisco Prime AR internal VSAs is 1760.

**Table C-11** Cisco Prime AR Internal VSAs

| SubAttr | VSA Name                    | Type       | Min-Max Value |
|---------|-----------------------------|------------|---------------|
| 1       | Realm                       | String     | 1-253         |
| 2       | Incoming-Translation-Groups | String     | 1-253         |
| 3       | Client-IP-Address           | IP Address | 1-253         |
| 4       | Subnet-Mask                 | IP Address | 1-253         |
| 5       | Outgoing-Translation-Groups | String     | 1-253         |
| 6       | Authentication-Service      | String     | 1-253         |
| 7       | Authorization-Service       | String     | 1-253         |
| 8       | DNIS                        | String     | 1-253         |
| 9       | CLID                        | String     | 1-253         |
| 10      | UserFilterMask              | String     | 1-253         |

Table C-11 Cisco Prime AR Internal VSAs (continued)

| SubAttr | VSA Name              | Type                           | Min-Max Value |
|---------|-----------------------|--------------------------------|---------------|
| 11      | Session-Manager       | String                         | 1-253         |
| 12      | Accounting-Service    | String                         | 1-253         |
| 13      | TimeRange             | String                         | 1-253         |
| 14      | AcceptedProfiles      | String                         | 1-253         |
| 15      | Policy                | String                         | 1-253         |
| 16      | Prefix                | String                         | 1-253         |
| 17      | Delimiters            | String                         | 1-253         |
| 18      | StripPrefix           | String                         | 1-253         |
| 19      | ODBC-Reply-Attribs    | String                         | 1-253         |
| 20      | ODBC-Check-Attribs    | String                         | 1-253         |
| 21      | Session-Service       | String                         | 1-253         |
| 22      | Prepaid               | ENUM:<br>0 = False<br>1 = True | 1-2           |
| 12      | Suffix                | String                         | 0-253         |
| 12      | Implicit-Auth-Enabled | ENUM:<br>0 = False<br>1 = True | 0-1           |
| 24      | StripSuffix           | ENUM:<br>0 = False<br>1 = True | 0-1           |
| 24      | Query-Service         | String                         | 0-253         |
| 92      | RepSourceIP           | String                         | 1-253         |
| 93      | RepTargetIP           | String                         | 1-253         |
| 94      | RepTxnNum             | String                         | 1-253         |
| 95      | RepTxnCRC             | String                         | 1-253         |
| 96      | RepTxnElementCount    | String                         | 1-253         |
| 97      | RepNeedsFullSync      | UINT32                         | 0-253         |
| 98      | RepNeedsReSync        | UINT32                         | 0-253         |
| 99      | RepLastRxTxnNum       | UINT32                         | 0-253         |
| 100     | RepLastRxTxnCRC       | UINT32                         | 0-253         |
| 101     | RepNeedsMember        | UINT32                         | 0-253         |
| 102     | RepMemberName         | String                         | 1-253         |
| 103     | RepMemberIP           | IP Address                     | 0-253         |
| 104     | RepMemberPort         | UINT32                         | 0-253         |
| 105     | RepMemberOrdinal      | UINT32                         | 0-253         |

**Table C-11 Cisco Prime AR Internal VSAs (continued)**

| SubAttr | VSA Name          | Type      | Min-Max Value |
|---------|-------------------|-----------|---------------|
| 106     | RepWorkLoad       | UINT32    | 0-253         |
| 107     | RepTxTime         | UINT32    | 0-253         |
| 108     | RepElementPath    | String    | 1-253         |
| 109     | RepElementValue   | String    | 1-253         |
| 110     | RepElementOrdinal | UINT32    | 0-253         |
| 111     | RepElementCRC     | UINT32    | 0-253         |
| 112     | RepElementType    | UINT32    | 0-253         |
| 113     | RepElementMode    | UINT32    | 0-253         |
| 114     | RepPartialElement | Undefined | 0-253         |

## Cisco VSAs

Table C-12 lists the Cisco VSAs. The vendor ID for Cisco VSAs is 9.

**Table C-12 Cisco VSAs**

| SubAttr | VSA Name                     | Type       | Min-Max Value |
|---------|------------------------------|------------|---------------|
| 1       | Cisco-AVPair                 | String     | 0-253         |
| 2       | Cisco-NAS-Port               | String     | 0-253         |
| 3       | Cisco-Fax-Account-ID-Origin  | String     | 0-253         |
| 4       | Cisco-Fax-Message-ID         | String     | 0-253         |
| 5       | Cisco-Fax-Pages              | String     | 0-253         |
| 6       | Cisco-FAX Cover Page Flag    | String     | 0-253         |
| 7       | Cisco-Fax-Modem-Time         | String     | 0-253         |
| 8       | Cisco-Fax-Connect-Speed      | String     | 0-253         |
| 9       | Cisco-Fax-Recipient-Count    | String     | 0-253         |
| 10      | Cisco-Fax-Process-Abort-Flag | String     | 0-253         |
| 11      | Cisco-Fax-DSN-Address        | String     | 0-253         |
| 12      | Cisco-Fax-DSN-Flag           | String     | 0-253         |
| 13      | Cisco-Fax-MDN-Address        | String     | 0-253         |
| 14      | Cisco-Fax-MDN-Flag           | String     | 0-253         |
| 15      | Cisco-Fax-Auth-Status        | String     | 0-253         |
| 16      | Cisco-Email-Server-Address   | IP Address |               |

Table C-12 Cisco VSAs (continued)

| SubAttr | VSA Name                                        | Type                         | Min-Max Value |
|---------|-------------------------------------------------|------------------------------|---------------|
| 17      | Cisco-Email-Server-ACK Flag                     | String                       | 0-253         |
| 18      | Cisco-Gateway-ID                                | String                       | 0-253         |
| 19      | Cisco-Call-Type                                 | String                       | 0-253         |
| 20      | Cisco-Port-Used                                 | String                       | 0-253         |
| 21      | Cisco-Abort-Cause                               | String                       | 0-253         |
| 22      | Cisco-CRS-Info                                  | String                       | 0-253         |
| 12      | Cisco-h312-Remote-Address                       | String                       | 0-253         |
| 24      | Cisco-h312-Conf-ID                              | String                       | 0-253         |
| 25      | Cisco-h312-Setup-Time                           | String                       | 0-253         |
| 26      | Cisco-h312-Call-Origin                          | String                       | 0-253         |
| 27      | Cisco-h312-Call-Type                            | String                       | 0-253         |
| 28      | Cisco-h312-Connect-Time                         | String                       | 0-253         |
| 29      | Cisco-h312-Disconnect-Time                      | String                       | 0-253         |
| 30      | Cisco-h312-Disconnect-Cause                     | String                       | 0-253         |
| 31      | Cisco-h312-Voice-Quality                        | String                       | 0-253         |
| 32      | Cisco-h312-Generic-IVR-Out                      | String                       | 0-253         |
| 33      | Cisco-h312-Gateway-ID                           | String                       | 0-253         |
| 34      | Cisco-3GPP2-AVPair                              | String                       | 0-253         |
| 35      | Cisco Connection ID-h312-incoming-connection-ID | String                       | 0-253         |
| 100     | Cisco-h312-Generic-IVR-In                       | String                       | 0-253         |
| 101     | Cisco-h312-Amount-Balance                       |                              |               |
| 102     | Cisco-h312-Time-Balance                         | String                       | 0-253         |
| 103     | Cisco-h312-Return-Code                          | String                       | 0-253         |
| 104     | Cisco-h312-Prompt-ID                            | String                       | 0-253         |
| 105     | Cisco-h312-Time-of-Day                          | String                       | 0-253         |
| 106     | Cisco-h312-Redirect-Number                      | String                       | 0-253         |
| 107     | Cisco-h312-Preferred-Language                   | String                       | 0-253         |
| 108     | Cisco-h312-Redirect-IP-Address                  | String                       | 0-253         |
| 109     | Cisco-h312-Billing-Model                        | ENUM:<br>postpaid<br>prepaid | 0-1           |
| 110     | Cisco-h312-Currency                             | String                       | 0-253         |

Table C-12 Cisco VSAs (continued)

| SubAttr | VSA Name                          | Type         | Min-Max Value |
|---------|-----------------------------------|--------------|---------------|
| 128     | Cisco-UCP-IP-Pool-ID              | String       | 0-253         |
| 129     | Cisco-UCP-User-Max-Sessions       | String       | 0-253         |
| 130     | Cisco-UCP-User-Session-Count      | String       | 0-253         |
| 131     | Cisco-UCP-Next-Session-ID         | String       | 0-253         |
| 132     | Cisco-UCP-VPDN-Max-Sessions       | String       | 0-253         |
| 133     | Cisco-UCP-VPDN-Session-Count      | String       | 0-253         |
| 134     | Cisco-UCP-B-Channel-Max-Sessions  | String       | 0-253         |
| 135     | Cisco-UCP-B-Channel-Session-Count | String       | 0-253         |
| 136     | Cisco-UCP-Status                  | String       | 0-253         |
| 137     | Cisco-UCP-BLOB-Attribute-Length   | String       | 0-253         |
| 138     | Cisco-UCP-Disable-Status          | String       | 0-253         |
| 139     | Cisco-UCP-Block-Access-Range      | String       | 0-253         |
| 140     | Cisco-UCP-Home-POP-ID             | String       | 0-253         |
| 175     | Cisco-UCP-IP-Addresses            | IP Addresses | 0-253         |
| 176     | Cisco-UCP-Session-Info            | String       | 0-253         |
| 211     | Cisco-Ascend AV pairs             | String       | 0-253         |
| 250     | Cisco-SSG-Account-Info            | String       | 0-253         |
| 251     | Cisco-SSG-Service-Info            | String       | 0-253         |
| 252     | Cisco-SSG-Command-Code            | String       | 0-253         |
| 253     | Cisco-SSG-Control-Info            | String       | 0-253         |

## Compatible VSAs

Table C-13 lists the Compatible VSAs. The vendor ID for Compatible VSAs is 255.

**Table C-13** Compatible VSAs

| SubAttr | VSA Name                          | Type       | Min-Max Value |
|---------|-----------------------------------|------------|---------------|
| 0       | Compatible-Tunnel-Delay           | UNIT32     | 0-253         |
| 1       | Compatible-Tunnel-Throughput      | UNIT32     | 0-253         |
| 3       | Compatible-Tunnel-Server-Endpoint | IP Address | 0-253         |
| 4       | Compatible-Tunnel-Group-Info      | String     | 0-253         |
| 5       | Compatible-Tunnel-Password        | String     | 0-253         |
| 6       | Compatible-Echo                   | UNIT32     | 0-253         |
| 7       | Compatible-Tunnel-Client-IPX      | UNIT32     | 0-253         |

## Microsoft VSAs

Table C-14 lists the Microsoft VSAs. The vendor ID for Microsoft VSAs is 311.

**Table C-14** Microsoft VSAs

| SubAttr | VSA Name                  | Type                                               | Min-Max Value |
|---------|---------------------------|----------------------------------------------------|---------------|
| 1       | MS-CHAP-Response          | String                                             | 50-50         |
| 2       | MS-CHAP-Error             | String                                             | 0-253         |
| 3       | MS-CHAP-CPW1              | String                                             | 70-70         |
| 4       | MS-CHAP-CPW2              | String                                             | 84-84         |
| 5       | MS-CHAP-LM-Enc-PW         | String                                             | 4-253         |
| 6       | MS-CHAP-NT-Enc-PW         | String                                             | 4-253         |
| 7       | MS-MPPE-Encryption-Policy | ENUM:<br>Encryption-Allowed<br>Encryption-Required | 1-2           |
| 8       | MS-MPPE-Encryption-Types  | String                                             | 0-4           |
| 9       | MS-RAS-Vendor             | UINT32                                             | 0-253         |
| 10      | MS-CHAP-Domain            | String                                             | 0-253         |
| 11      | MS-CHAP-Challenge         | String                                             | 0-253         |
| 12      | MS-CHAP-MPPE-Keys         | String                                             | 32-32         |
| 13      | MS-BAP-Usage              | ENUM:<br>Not allowed<br>Allowed<br>Required        | 0-2           |

Table C-14 Microsoft VSAs (continued)

| SubAttr | VSA Name                       | Type                                                                                                      | Min-Max Value |
|---------|--------------------------------|-----------------------------------------------------------------------------------------------------------|---------------|
| 14      | MS-Link-Utilization-Threshold  | UINT32                                                                                                    | 0-253         |
| 15      | MS-Link-Drop-Time-Limit        | String                                                                                                    | 0-253         |
| 16      | MS-MPPE-Send-Key               | String                                                                                                    | 0-253         |
| 17      | MS-MPPE-Recv-Key               | String                                                                                                    | 0-253         |
| 18      | MS-RAS-Version                 | String                                                                                                    | 0-253         |
| 19      | MS-Old-ARAP-Password           | String                                                                                                    | 0-253         |
| 20      | MS-New-ARAP-Password           | String                                                                                                    | 0-253         |
| 21      | MS-ARAP-Password-Change-Reason | ENUM:<br>Just-Change-Password<br>Expired-Password<br>Admin-Requires-Password-Change<br>Password-Too-Short | 1-4           |
| 22      | MS-Filter                      | String                                                                                                    | 0-253         |
| 12      | MS-Acct-Auth-Type              | ENUM:<br>PAP<br>CHAP<br>MS-CHAP-1<br>MS-CHAP-2<br>EAP                                                     | 1-5           |
| 26      | MS-CHAP2-Success               | String                                                                                                    | 43-43         |
| 27      | MS-CHAP2-CPW8                  | String                                                                                                    | 68-68         |
| 29      | MS-Secondary-DNS-Server        | IP Address                                                                                                | 68-68         |
| 31      | MS-Secondary-NBNS-Server       | IP Address                                                                                                | 70-70         |
| 33      | MS-ARAP-Challenge              | String                                                                                                    | 8-8           |



## Nomadix VSAs

Table C-15 lists the Nomadix VSAs. The vendor ID for Nomadix VSAs is 3309.

**Table C-15** *Nomadix VSAs*

| SubAttr | VSA Name            | Type   | Min-Max Value |
|---------|---------------------|--------|---------------|
| 1       | Nomadix-Bw-Up 0 253 | UINT32 | 0-253         |
| 2       | Nomadix-Dw-Down     | UINT32 | 0-253         |

## RedBack VSAs

Table C-16 lists the RedBack VSAs. The vendor ID for RedBack VSAs is 1252.

**Table C-16** *RedBack VSAs*

| SubAttr | VSA Name                    | Type   | Min-Max Value |
|---------|-----------------------------|--------|---------------|
| 1       | RedBack-Client-DNS-Pri      | String | 0-253         |
| 2       | RedBack-Client-DNS-Sec      | String | 0-253         |
| 3       | RedBack-DHCP-Max-Leases     | String | 0-253         |
| 4       | RedBack-Context-Name        | String | 0-253         |
| 5       | RedBack-Bridge-Group        | String | 0-253         |
| 6       | RedBack-BG-Aging-Time       | String | 0-253         |
| 7       | RedBack-BG-Path-Cost        | String | 0-253         |
| 8       | RedBack-BG-Span-Dis         | String | 0-253         |
| 9       | RedBack-BG-Trans-BPDU       | String | 0-253         |
| 10      | RedBack-Rate-Limit-Rate     | String | 0-253         |
| 11      | RedBack-Rate-Limit-Burst    | String | 0-253         |
| 12      | RedBack-Police-Rate         | String | 0-253         |
| 13      | RedBack-Police-Burst        | String | 0-253         |
| 14      | RedBack-Source-Validation   | String | 0-253         |
| 15      | RedBack-Tunnel-Domain       | String | 0-253         |
| 16      | RedBack-Tunnel-Local-Name   | String | 0-253         |
| 17      | RedBack-Tunnel-Remote-Name  | String | 0-253         |
| 18      | RedBack-Tunnel-Function     | String | 0-253         |
| 21      | RedBack-Tunnel-Max-Sessions | String | 0-253         |
| 22      | RedBack-Tunnel-Max-Tunnels  | String | 0-253         |
| 12      | RedBack-Tunnel-Session-Auth | String | 0-253         |
| 24      | RedBack-Tunnel-Window       | String | 0-253         |
| 25      | RedBack-Tunnel-Retransmit   | String | 0-253         |

Table C-16 RedBack VSAs (continued)

| SubAttr | VSA Name                        | Type   | Min-Max Value |
|---------|---------------------------------|--------|---------------|
| 26      | RedBack-Tunnel-Cmd-Timeout      | String | 0-253         |
| 27      | RedBack-PPPOE-URL               | String | 0-253         |
| 28      | RedBack-PPPOE-MOTM              | String | 0-253         |
| 29      | RedBack-Tunnel-Group            | String | 0-253         |
| 30      | RedBack-Tunnel-Context          | String | 0-253         |
| 31      | RedBack-Tunnel-Algorithm        | String | 0-253         |
| 32      | RedBack-Tunnel-Deadtime         | String | 0-253         |
| 33      | RedBack-Mcast-Send              | String | 0-253         |
| 34      | RedBack-Mcast-Receive           | String | 0-253         |
| 35      | RedBack-Mcast-MaxGroups         | String | 0-253         |
| 36      | RedBack-Ip-Address-Pool-Name    | String | 0-253         |
| 37      | RedBack-Tunnel-DNIS             | String | 0-253         |
| 38      | RedBack-Medium-Type             | String | 0-253         |
| 39      | RedBack-PVC-Encapsulation-Type  | String | 0-253         |
| 40      | RedBack-PVC-Profile-Name        | String | 0-253         |
| 41      | RedBack-PVC-Circuit-Padding     | String | 0-253         |
| 42      | RedBack-Bind-Type               | String | 0-253         |
| 43      | RedBack-Bind-Auth-Protocol      | String | 0-253         |
| 44      | RedBack-Bind-Auth-Max-Sessions  | String | 0-253         |
| 45      | RedBack-Bind-Bypass-Bypass      | String | 0-253         |
| 46      | RedBack-Bind-Auth-Context       | String | 0-253         |
| 47      | RedBack-Bind-Auth-Service-Grp   | String | 0-253         |
| 48      | RedBack-Bind-Bypass-Context     | String | 0-253         |
| 49      | RedBack-Bind-Int-Context        | String | 0-253         |
| 50      | RedBack-Bind-Tun-Context        | String | 0-253         |
| 51      | RedBack-Bind-Ses-Context        | String | 0-253         |
| 52      | RedBack-Bind-Dot1q-Slot         | String | 0-253         |
| 53      | RedBack-Bind-Dot1q-Port         | String | 0-253         |
| 54      | RedBack-Bind-Dot1q-Vlan-Tag-Id  | String | 0-253         |
| 55      | RedBack-Bind-Int-Interface-Name | String | 0-253         |
| 56      | RedBack-Bind-L2TP-Tunnel-Name   | String | 0-253         |

Table C-16 RedBack VSAs (continued)

| SubAttr | VSA Name                                    | Type   | Min-Max Value |
|---------|---------------------------------------------|--------|---------------|
| 57      | RedBack-Bind-L2TP-Flow-Contr<br>ol          | String | 0-253         |
| 58      | RedBack-Bind-Sub-User-At-Con<br>text        | String | 0-253         |
| 59      | RedBack-Bind-Sub-Password                   | String | 0-253         |
| 60      | RedBack-Ip-Host-Addr                        | String | 0-253         |
| 61      | RedBack-IP-TOS-Field                        | String | 0-253         |
| 62      | RedBack-NAS-Real-Port                       | String | 0-253         |
| 63      | RedBack-Tunnel-Session-Auth-C<br>tx         | String | 0-253         |
| 64      | RedBack-Tunnel-Session-Auth-S<br>ervice-Grp | String | 0-253         |
| 65      | RedBack-Tunnel-Rate-Limit-Rat<br>e          | String | 0-253         |
| 66      | RedBack-Tunnel-Rate-Limit-Bur<br>st         | String | 0-253         |
| 67      | RedBack-Tunnel-Police-Rate                  | String | 0-253         |
| 68      | RedBack-Tunnel-Police-Burst                 | String | 0-253         |
| 69      | RedBack-Tunnel-L2F-Second-Pa<br>ssword      | String | 0-253         |
| 128     | RedBack-Acct-Input-Octets-64                | String | 0-253         |
| 129     | RedBack-Acct-Output-Octets-64               | String | 0-253         |
| 130     | RedBack-Acct-Input-Packets-64               | String | 0-253         |
| 131     | RedBack-Acct-Output-Packets-6<br>4          | String | 0-253         |
| 132     | RedBack-Assigned-IP-Address                 | String | 0-253         |
| 133     | RedBack-Acct-Mcast-In-Octets                | String | 0-253         |
| 134     | RedBack-Acct-Mcast-Out-Octets               | String | 0-253         |
| 135     | RedBack-Acct-Mcast-In-Packets               | String | 0-253         |
| 136     | RedBack-Acct-Mcast-Out-Packet<br>s          | String | 0-253         |
| 137     | RedBack-LAC-Port                            | String | 0-253         |
| 138     | RedBack-LAC-Real-Port                       | String | 0-253         |
| 139     | RedBack-LAC-Port-Type                       | String | 0-253         |
| 140     | RedBack-LAC-Real-Port-Type                  | String | 0-253         |

## RedCreek VSAs

Table C-17 lists the RedCreek VSAs. The vendor ID for RedCreek VSAs is 1958.

**Table C-17 RedCreek VSAs**

| SubAttr | VSA Name                       | Type       | Min-Max Value |
|---------|--------------------------------|------------|---------------|
| 6       | RedCreek-Tunneled-IP-Netmask   | IP Address | 0-253         |
| 7       | RedCreek-Tunneled-Gateway      | IP Address | 0-253         |
| 9       | RedCreek-Tunneled-WINS-Server1 | String     | 0-253         |
| 10      | RedCreek-Tunneled-WINS-Server2 | String     | 0-253         |
| 11      | RedCreek-Tunneled-HostName     | String     | 0-253         |
| 12      | RedCreek-Tunneled-DomainName   | String     | 0-253         |
| 13      | RedCreek-Tunneled-Search-List  | String     | 0-253         |

## TACACS+ VSAs

Table C-18 lists the TACACS+ VSAs. The vendor ID for TACACS+ VSAs is 268435456.

**Table C-18 TACACS+ VSAs**

| SubAttr | VSA Name                   | Type                                                                | Min-Max Value    |
|---------|----------------------------|---------------------------------------------------------------------|------------------|
| 1       | Tacacs-Version             | ENUM:<br>192 = 12.0<br>193 = 12.1                                   | 0-255            |
| 2       | Tacacs-Type                | ENUM:<br>1 = Authentication<br>2 = Authorization<br>3 = Accounting  | 1-3              |
| 3       | Tacacs-Sequence-Number     | UINT32                                                              | 0-1              |
| 4       | Tacacs-Session-Id          | UINT32                                                              | 0-2147483<br>647 |
| 5       | Tacacs-Action              | ENUM:<br>1 = Login<br>2 = ChPass<br>3 = SendPass<br>4 = SendAuth    | 0-253            |
| 6       | Tacacs-Privilege-Level     | UINT32                                                              | 0-15             |
| 7       | Tacacs-Authentication-Type | ENUM:<br>1 = ASCII<br>2 = PAP<br>3 = CHAP<br>4 = ARAP<br>5 = MSCHAP | 1-5              |

Table C-18 TACACS+ VSAs (continued)

| SubAttr | VSA Name                            | Type                                                                                                                  | Min-Max Value |
|---------|-------------------------------------|-----------------------------------------------------------------------------------------------------------------------|---------------|
| 8       | Tacacs-Service                      | ENUM:<br>1 = Login<br>2 = Enable<br>3 = PPP<br>4 = ARAP<br>5 = PT<br>6 = RCMD<br>7 = X25<br>8 = NASI<br>9 = FWPROXY   | 1-9           |
| 9       | Tacacs-User-Name                    | String                                                                                                                | 0-253         |
| 10      | Tacacs-Port                         | String                                                                                                                | 0-253         |
| 11      | Tacacs-Remote-Address               | String                                                                                                                | 0-253         |
| 12      | Tacacs-Data                         | String                                                                                                                | 0-253         |
| 13      | Tacacs-User-Message                 | String                                                                                                                | 0-253         |
| 14      | Tacacs-User-Data                    | String                                                                                                                | 0-253         |
| 15      | Tacacs-Authentication-Continue-Flag | ENUM:<br>0 = Continue<br>1 = Abort                                                                                    | 0-1           |
| 16      | Tacacs-Authentication-Reply-Flag    | ENUM:<br>0 = Echo<br>1 = NoEcho                                                                                       | 0-1           |
| 17      | Tacacs-Authentication-Reply-Status  | ENUM:<br>1 = Pass<br>2 = Fail<br>3 = GetData<br>4 = GetUser<br>5 = GetPass<br>6 = Restart<br>7 = Error<br>33 = Follow | 0-33          |
| 18      | Tacacs-Authorization-Reply-Status   | ENUM:<br>1 = PassAdd<br>2 = PassRepl<br>16 = Fail<br>17 = Error<br>33 = Follow                                        | 0-33          |
| 19      | Tacacs-Server-Message               | String                                                                                                                | 0-253         |

Table C-18 TACACS+ VSAs (continued)

| SubAttr | VSA Name                       | Type                                                                                                                                                                                                      | Min-Max Value |
|---------|--------------------------------|-----------------------------------------------------------------------------------------------------------------------------------------------------------------------------------------------------------|---------------|
| 20      | Tacacs-Authentication-Method   | ENUM:<br>0 = NotSet<br>1 = None<br>2 = KRB5<br>3 = Line<br>4 = Enable<br>5 = Local<br>6 = TacacsPlus<br>7 = Guest<br>16 = Radius<br>17 = KRB4<br>32 = RCMD                                                | 0-32          |
| 21      | Tacacs-AVPair                  | String                                                                                                                                                                                                    | 0-253         |
| 22      | Tacacs-Accounting-Reply-Status | ENUM:<br>1 = Success<br>2 = Fail<br>33 = Follow                                                                                                                                                           | 0-33          |
| 12      | Tacacs-Header-Flag             | ENUM:<br>0 = Encrypted<br>1 = Unencrypted<br>4 = Encrypted + ReuseConnection<br>5 = Unencrypted + ReuseConnection                                                                                         | 0-5           |
| 24      | Tacacs-User-Password           | String                                                                                                                                                                                                    | 0-253         |
| 25      | Tacacs-Accounting-Request-Flag | ENUM:<br>1 = More<br>2 = Start<br>3 = Start<br>4 = Stop<br>5 = Stop<br>6 = Start<br>7 = Start<br>8 = Update<br>9 = More<br>10 = Start<br>11 = Start<br>12 = Stop<br>13 = Stop<br>14 = Start<br>15 = Start | 0-33          |
| 26      | Tacacs-CHAP-Password           | CHAP_PASSWORD                                                                                                                                                                                             | 17-17         |
| 27      | Tacacs-CHAP-Challenge          | String                                                                                                                                                                                                    | 0-253         |

**Table C-18 TACACS+ VSAs (continued)**

| SubAttr | VSA Name                | Type   | Min-Max Value |
|---------|-------------------------|--------|---------------|
| 28      | Tacacs-MSCHAP-Response  | String | 50-50         |
| 29      | Tacacs-MSCHAP-Challenge | String | 0-253         |

## Telebit VSAs

Table C-19 lists the Telebit VSAs. The vendor ID for Telebit VSAs is 117.

**Table C-19 Telebit VSAs**

| SubAttr | VSA Name                 | Type   | Min-Max Value |
|---------|--------------------------|--------|---------------|
| 1       | Telebit-Login-Command    | String | 0-253         |
| 2       | Telebit-Port-Name        | String | 0-253         |
| 3       | Telebit-Activate-Command | String | 0-253         |
| 4       | Telebit-Accounting-Info  | String | 0-253         |
| 5       | Telebit-Login-Option     | String | 0-253         |

## Unisphere VSAs

Table C-20 lists the Unisphere VSAs. The vendor ID for RedBack VSAs is 4874.

**Table C-20 Unisphere VSAs**

| SubAttr | VSA Name                        | Type   | Min-Max Value |
|---------|---------------------------------|--------|---------------|
| 1       | Unisphere-Virtual-Router        | String | 0-253         |
| 2       | Unisphere-Local-Address-Pool    | String | 0-253         |
| 3       | Unisphere-Local-Interface       | String | 0-253         |
| 4       | Unisphere-Primary-DNS           | String | 0-253         |
| 5       | Unisphere-Secondary-DNS         | String | 0-253         |
| 6       | Unisphere-Primary-WINS          | String | 0-253         |
| 7       | Unisphere-Secondary-WINS        | String | 0-253         |
| 8       | Unisphere-Tunnel-Virtual-Router | String | 0-253         |
| 9       | Unisphere-Tunnel-Password       | String | 0-253         |
| 10      | Unisphere-Ingress-Policy-Name   | String | 0-253         |
| 11      | Unisphere-Egress-Policy-Name    | String | 0-253         |

**Table C-20 Unisphere VSAs (continued)**

| SubAttr | VSA Name                        | Type   | Min-Max Value |
|---------|---------------------------------|--------|---------------|
| 12      | Unisphere-Ingress-Statistics    | String | 0-253         |
| 13      | Unisphere-Egress-Statistics     | String | 0-253         |
| 14      | Unisphere-Service-Category      | String | 0-253         |
| 15      | Unisphere-PCR                   | String | 0-253         |
| 16      | Unisphere-SCR                   | String | 0-253         |
| 17      | Unisphere-MBS                   | String | 0-253         |
| 18      | Unisphere-Init-CLI-Access-Level | String | 0-253         |
| 19      | Unisphere-Allow-All-VR-Access   | String | 0-253         |
| 20      | Unisphere-Alt-CLI-Access-Level  | String | 0-253         |
| 21      | Unisphere-Alt-CLI-VRouter-Name  | String | 0-253         |
| 22      | Unisphere-SA-Validate           | String | 0-253         |
| 12      | Unisphere-IGMP-enable           | String | 0-253         |
| 24      | Unisphere-PPPoE-Description     | String | 0-253         |
| 25      | Unisphere-Redirect-VRouter-Name | String | 0-253         |

## USR VSAs

[Table C-21](#) lists the USR VSAs. The vendor ID for USR VSAs is 429.



Table C-21 USR VSAs

| SubAttr | VSA Name                  | Type                                                                                                                                                                                                                                                                                                                                                                                                                                     | Min-Max Value |
|---------|---------------------------|------------------------------------------------------------------------------------------------------------------------------------------------------------------------------------------------------------------------------------------------------------------------------------------------------------------------------------------------------------------------------------------------------------------------------------------|---------------|
| 1       | USR-DTE-Data-Idle-Timeout | UINT32                                                                                                                                                                                                                                                                                                                                                                                                                                   | 0-0           |
| 2       | USR-Default-DTE-Data-Rate | ENUM:<br>110_BPS<br>300_BPS<br>600_BPS<br>1200_BPS<br>2400_BPS<br>4800_BPS<br>7200_BPS<br>9600_BPS<br>12K_BPS<br>14.4K_BPS<br>16.8_BPS<br>19.2K_BPS<br>38.4K_BPS<br>75_BPS<br>450_BPS<br>UNKNOWN_BPS<br>57.6K_BPS<br>21.6K_BPS<br>24K_BPS<br>26K_BPS<br>28K_BPS<br>115K_BPS<br>31K_BPS<br>33K_BPS<br>25333_BPS<br>110_BPS<br>300_BPS<br>600_BPS<br>1200_BPS<br>2400_BPS<br>26666_BPS<br>28000_BPS<br>29333_BPS<br>30666_BPS<br>32000_BPS | 1-54          |

Table C-21 USR VSAs (continued)

| SubAttr | VSA Name                      | Type                                                                                                                                                                                                                                                                                                                 | Min-Max Value |
|---------|-------------------------------|----------------------------------------------------------------------------------------------------------------------------------------------------------------------------------------------------------------------------------------------------------------------------------------------------------------------|---------------|
| 2       | USR-Default-DTE-Data-Rate     | 33333_BPS<br>34666_BPS<br>36000_BPS<br>37333_BPS<br>38666_BPS<br>40000_BPS<br>41333_BPS<br>42666_BPS<br>44000_BPS<br>45333_BPS<br>46666_BPS<br>48000_BPS<br>49333_BPS<br>50666_BPS<br>52000_BPS<br>53333_BPS<br>54666_BPS<br>56000_BPS<br>57333_BPS<br>58666_BPS<br>60000_BPS<br>61333_BPS<br>62666_BPS<br>64000_BPS |               |
| 3       | USR-Last-Number-Dialed-Out    | String                                                                                                                                                                                                                                                                                                               | 1-253         |
| 4       | USR-Sync-Async-Mode           | ENUM:<br>Asynchronous<br>Synchronous                                                                                                                                                                                                                                                                                 | 1-2           |
| 5       | USR-Originate-Answer-Mode     | ENUM:<br>Originate_in_Originate_Mode<br>Originate_in_Answer_Mode<br>Answer_in_Originate_Mode<br>Answer_in_Answer_Mode                                                                                                                                                                                                | 1-4           |
| 6       | USR-Failure-to-Connect-Reason | ENUM:                                                                                                                                                                                                                                                                                                                | 1-67          |

Table C-21 USR VSAs (continued)

| SubAttr | VSA Name                      | Type                                                                                                                                                                                                                                                                                                                                                                                                                                                                                                                                                                                                              | Min-Max Value |
|---------|-------------------------------|-------------------------------------------------------------------------------------------------------------------------------------------------------------------------------------------------------------------------------------------------------------------------------------------------------------------------------------------------------------------------------------------------------------------------------------------------------------------------------------------------------------------------------------------------------------------------------------------------------------------|---------------|
| 7       | USR-Initial-Tx-Link-Data-Rate | ENUM:<br>110_BPS<br>14.4K_BPS<br>16.8_BPS<br>19.2K_BPS<br>38.4K_BPS<br>75_BPS<br>450_BPS<br>UNKNOWN_BPS<br>57.6K_BPS<br>21.6K_BPS<br>24K_BPS<br>300_BPS<br>26K_BPS<br>28K_BPS<br>115K_BPS<br>31K_BPS<br>33K_BPS<br>25333_BPS<br>26666_BPS<br>28000_BPS<br>29333_BPS<br>30666_BPS<br>600_BPS<br>32000_BPS<br>33333_BPS<br>34666_BPS<br>36000_BPS<br>37333_BPS<br>38666_BPS<br>40000_BPS<br>41333_BPS<br>42666_BPS<br>44000_BPS<br>1200_BPS<br>45333_BPS<br>46666_BPS<br>48000_BPS<br>49333_BPS<br>50666_BPS<br>52000_BPS<br>53333_BPS<br>54666_BPS<br>56000_BPS<br>57333_BPS<br>2400_BPS<br>58666_BPS<br>60000_BPS | 1-54          |

Table C-21 USR VSAs (continued)

| SubAttr | VSA Name                                     | Type                                                                                                                                                                                                                                                                                        | Min-Max Value |
|---------|----------------------------------------------|---------------------------------------------------------------------------------------------------------------------------------------------------------------------------------------------------------------------------------------------------------------------------------------------|---------------|
| 7       | USR-Initial-Tx-Link-Data-Rate<br>(continued) | 61333_BPS<br>62666_BPS<br>64000_BPS<br>4800_BPS<br>7200_BPS<br>9600_BPS<br>12K_BPS                                                                                                                                                                                                          |               |
| 8       | USR-Final-Tx-Link-Data-Rate                  | ENUM:<br>110_BPS<br>14.4K_BPS<br>16.8_BPS<br>19.2K_BPS<br>38.4K_BPS<br>75_BPS<br>450_BPS<br>UNKNOWN_BPS<br>57.6K_BPS<br>21.6K_BPS<br>24K_BPS<br>300_BPS<br>26K_BPS<br>28K_BPS<br>115K_BPS<br>31K_BPS<br>33K_BPS<br>25333_BPS<br>26666_BPS<br>28000_BPS<br>29333_BPS<br>30666_BPS<br>600_BPS | 1-54          |

Table C-21 USR VSAs (continued)

| SubAttr | VSA Name                    | Type                                                                                                                                                                                                                                  | Min-Max Value |
|---------|-----------------------------|---------------------------------------------------------------------------------------------------------------------------------------------------------------------------------------------------------------------------------------|---------------|
| 8       | USR-Final-Tx-Link-Data-Rate | 32000_BPS<br>33333_BPS<br>34666_BPS<br>36000_BPS<br>37333_BPS<br>38666_BPS<br>40000_BPS<br>41333_BPS<br>42666_BPS<br>44000_BPS<br>1200_BPS<br>45333_BPS<br>46666_BPS<br>48000_BPS<br>49333_BPS<br>50666_BPS<br>52000_BPS<br>53333_BPS | 1-54          |
| 8       | USR-Final-Tx-Link-Data-Rate | 54666_BPS<br>56000_BPS<br>57333_BPS<br>2400_BPS<br>58666_BPS<br>60000_BPS<br>61333_BPS<br>62666_BPS<br>64000_BPS<br>4800_BPS<br>7200_BPS<br>9600_BPS                                                                                  |               |

Table C-21 USR VSAs (continued)

| SubAttr | VSA Name                       | Type                                                                                                                                                                                                                                                                                                                                                                             | Min-Max Value |
|---------|--------------------------------|----------------------------------------------------------------------------------------------------------------------------------------------------------------------------------------------------------------------------------------------------------------------------------------------------------------------------------------------------------------------------------|---------------|
| 9       | USR-Modulation-Type            | ENUM:<br>usRoboticsHST<br>bell208b<br>v21FaxClass1<br>v27FaxClass1<br>v29FaxClass1<br>v17FaxClass1<br>v21FaxClass2<br>v27FaxClass2<br>v29FaxClass2<br>v17FaxClass2<br>v32Terbo<br>ccittV32<br>v34<br>vFC<br>v34plus<br>x2<br>v110<br>v120<br>x75<br>ayncSyncPPP<br>clearChannel<br>ccittV22bis<br>bell103<br>ccittV21<br>bell212<br>ccittV32bis<br>ccittV12<br>negotiationFailed | 1-28          |
| 9       | USR-Modulation-Type            | ENUM:                                                                                                                                                                                                                                                                                                                                                                            |               |
| 10      | USR-Equalization-Type          | ENUM:<br>Long<br>Short                                                                                                                                                                                                                                                                                                                                                           | 1-2           |
| 112     | USR-Characters-Sent            | UINT32                                                                                                                                                                                                                                                                                                                                                                           | 0-0           |
| 13      | USR-Characters-Received        | UINT32                                                                                                                                                                                                                                                                                                                                                                           | 0-0           |
| 14      | USR-Blocks-Sent                | UINT32                                                                                                                                                                                                                                                                                                                                                                           | 0-0           |
| 15      | USR-Blocks-Received 0          | UINT32                                                                                                                                                                                                                                                                                                                                                                           | 0-0           |
| 16      | USR-Blocks-Resent              | UINT32                                                                                                                                                                                                                                                                                                                                                                           | 0-0           |
| 17      | USR-Retrains-Requested         | UINT32                                                                                                                                                                                                                                                                                                                                                                           | 0-0           |
| 18      | USR-Retrains-Granted           | UINT32                                                                                                                                                                                                                                                                                                                                                                           |               |
| 19      | USR-Line-Reversals             | UINT32                                                                                                                                                                                                                                                                                                                                                                           |               |
| 20      | USR-Number-Of-Characters-Lost0 | UINT32                                                                                                                                                                                                                                                                                                                                                                           | 0-0           |

Table C-21 USR VSAs (continued)

| SubAttr | VSA Name                    | Type                                                                                                                                                                             | Min-Max Value |
|---------|-----------------------------|----------------------------------------------------------------------------------------------------------------------------------------------------------------------------------|---------------|
| 21      | USR-Back-Channel-Data-Rate  | ENUM :<br>450BPS<br>300BPS<br>None                                                                                                                                               | 1-3           |
| 22      | USR-Number-of-Blers         | UINT32                                                                                                                                                                           | 0-0           |
| 12      | USR-Number-of-Link-Timeouts | UINT32                                                                                                                                                                           | 0-0           |
| 24      | USR-Number-of-Fallbacks     | UINT32                                                                                                                                                                           | 0-0           |
| 25      | USR-Number-of-Upshifts      | UINT32                                                                                                                                                                           | 0-0           |
| 26      | USR-Number-of-Link-NAKs     | UINT32                                                                                                                                                                           | 0-0           |
| 27      | USR-Simplified-MNP-Levels   | ENUM:<br>Unknown<br>NON_ARQ<br>MNP10ec<br>LAPMAC<br>V42ETC2<br>V42SREJ<br>PIAFS<br>V120<br>X75<br>MNP3<br>MNP4<br>V42<br>HST<br>synchronous<br>MNP2<br>MNP10(Cellular)<br>V42ETC | 0-16          |

Table C-21 USR VSAs (continued)

| SubAttr | VSA Name                | Type                                                                                                                                                                                                                                                                                                                                                                                                                                                                                                  | Min-Max Value |
|---------|-------------------------|-------------------------------------------------------------------------------------------------------------------------------------------------------------------------------------------------------------------------------------------------------------------------------------------------------------------------------------------------------------------------------------------------------------------------------------------------------------------------------------------------------|---------------|
| 28      | USR-Connect-Term-Reason | ENUM:<br>dtrDrop<br>retransmitLimit<br>linkDisconnectMsg<br>Received<br>noLoopCurrent<br>invalidSpeed<br>unableToRetrain<br>managementComm<br>and<br>noDialTone<br>keyAbort<br>lineBusy<br>noAnswer<br>escapeSequence<br>voice<br>noAnswerTone<br>noCarrier<br>undetermined<br>v42SabmeTimeout<br>v42BreakTimeout<br>v42DisconnectCmd<br>v42IdExchangeFail<br>v42BadSetup<br>v42InvalidCodeWo<br>rd<br>athCommand<br>v42StringToLong<br>v42InvalidComman<br>d<br>none<br>v32Cleardown<br>dialSecurity | 1-67          |



Table C-21 USR VSAs (continued)

| SubAttr | VSA Name                | Type                                                                                                                                                                                                                                                                                                                                                                                                                                                                                                                                                                                                                                                                                                       | Min-Max Value |
|---------|-------------------------|------------------------------------------------------------------------------------------------------------------------------------------------------------------------------------------------------------------------------------------------------------------------------------------------------------------------------------------------------------------------------------------------------------------------------------------------------------------------------------------------------------------------------------------------------------------------------------------------------------------------------------------------------------------------------------------------------------|---------------|
| 28      | USR-Connect-Term-Reason | remoteAccessDenied<br>loopLoss<br>ds0Teardown<br>promptNotEnabled<br>noPromptingInSync<br>carrierLoss<br>nonArqMode<br>modeIncompatible<br>noPromptInNonARQ<br>dialBackLink<br>linkAbort<br>autopassFailed<br>pbGenericError<br>pbLinkErrTxPreAck<br>pbLinkErrTxTardyACK<br>pbTransmitBusTimeout<br>inactivityTimeout<br>pbReceiveBusTimeout<br>pbLinkErrTxTAL<br>pbLinkErrRxTAL<br>pbTransmitMasterTimeout<br>pbClockMissing<br>pbReceivedLsWhileLinkUp<br>pbOutOfSequenceFrame<br>pbBadFrame<br>pbAckWaitTimeout<br>pbReceivedAckSeqErr<br>mnpIncompatible<br>pbReceiveOvrflwRRFail<br>pbReceiveMsgBufOvrflw<br>rcvdGatewayDiscCmd<br>tokenPassingTimeout<br>dspInterruptTimeout<br>mnpProtocolViolation |               |

Table C-21 USR VSAs (continued)

| SubAttr | VSA Name                       | Type                                                                                       | Min-Max Value |
|---------|--------------------------------|--------------------------------------------------------------------------------------------|---------------|
| 28      | USR-Connect-Term-Reason        | class2FaxHangupCmd<br>hstSpeedSwitchTimeout<br>undefined<br>remotePassword<br>linkPassword |               |
| 29      | USR-DTR-False-Timeout          | UINT32                                                                                     | 0-0           |
| 30      | USR-Fallback-Limit             | UINT32                                                                                     | 0-0           |
| 31      | USR-Block-Error-Count-Limit    | UINT32                                                                                     | 0-0           |
| 32      | USR-Simplified-V42bis-Usage    | ENUM:<br>None<br>ccittV42bis<br>mnpLevel5                                                  | 1-3           |
| 33      | USR-DTR-True-Timeou            | UINT32                                                                                     | 0-0           |
| 34      | USR-Last-Number-Dialed-In-DNIS | String                                                                                     | 1-253         |
| 35      | USR-Last-Callers-Number-ANI    | String                                                                                     | 1-253         |
| 36      | USR-Mbi-Ct-PRI-Card-Slot       | UINT32                                                                                     | 0-0           |
| 37      | USR-Mbi-Ct-TDM-Time-Slot       | UINT32                                                                                     | 0-0           |
| 38      | USR-Mbi-Ct-PRI-Card-Span-Line  | UINT32                                                                                     | 0-0           |
| 39      | USR-Mbi-Ct-BChannel-Used       | UINT32                                                                                     | 0-0           |
| 40      | USR-IP-Input-Filter            | String                                                                                     | 1-253         |
| 41      | USR-IPX-Input-Filter           | String                                                                                     | 1-253         |
| 42      | USR-IP-Output-Filter           | String                                                                                     | 1-253         |
| 43      | USR-IPX-Output-Filter          | String                                                                                     | 1-253         |
| 44      | USR-SAP-Output-Filter          | String                                                                                     | 1-253         |
| 45      | USR-VPN-ID                     | UINT32                                                                                     | 0-0           |
| 46      | USR-VPN-Name                   | String                                                                                     | 1-253         |
| 47      | USR-VPN-Neighbor               | String                                                                                     | 1-253         |
| 48      | USR-Framed-Routing-V2          | ENUM:<br>RIP-V2-Off<br>RIP-V2-On                                                           | 1-2           |
| 49      | USR-VPN-Gateway                | String                                                                                     | 1-253         |
| 50      | USR-Tunnel-Authenticato        | String                                                                                     | 1-253         |
| 51      | USR-Packet-Index               | String                                                                                     | 1-253         |
| 52      | USR-Cutoff                     | String                                                                                     | 1-253         |

Table C-21 USR VSAs (continued)

| SubAttr | VSA Name                   | Type   | Min-Max Value |
|---------|----------------------------|--------|---------------|
| 53      | USR-Access-Accept-Packet   | String | 1-253         |
| 54      | USR-Primary-DNS-Server     | String | 1-253         |
| 55      | USR-Secondary-DNS-Server   | String | 1-253         |
| 56      | USR-Primary-NBNS-Server    | String | 1-253         |
| 57      | USR-Secondary-NBNS-Server  | String | 1-253         |
| 58      | USR-Syslog-Tap             | UINT32 | 0-0           |
| 59      | USR-Chassis-Call-Slot      | UINT32 | 0-0           |
| 60      | USR-Chassis-Call-Span      | UINT32 | 0-0           |
| 61      | -Chassis-Call-Channel      | UINT32 | 0-0           |
| 62      | USR-Keypress-Timeout       | UINT32 | 0-0           |
| 63      | USR-Unauthenticated-Time   | UINT32 | 0-0           |
| 64      | USR-Bearer-Capabilities    | UINT32 | 0-0           |
| 65      | USR-Speed-Of-Connection    | UINT32 | 0-0           |
| 66      | USR-Max-Channels           | UINT32 | 0-0           |
| 67      | USR-Channel-Expansion      | UINT32 | 0-0           |
| 68      | USR-Channel-Decrement      | UINT32 | 0-0           |
| 69      | USR-Expansion-Algorithm    | UINT32 | 0-0           |
| 70      | USR-Compression-Algorithm  | UINT32 | 0-0           |
| 71      | USR-Receive-Acc-Map        | UINT32 | 0-0           |
| 72      | USR-Transmit-Acc-Map       | UINT32 | 0-0           |
| 73      | USR-Compression-Reset-Mode | UINT32 | 0-0           |
| 74      | USR-Min-Compression-Size   | UINT32 | 0-0           |
| 75      | USR-IP                     | UINT32 | 0-0           |
| 76      | USR-IPX                    | UINT32 | 0-0           |
| 77      | USR-Filter-Zones           | UINT32 | 0-0           |
| 78      | USR-Appletalk              | UINT32 | 0-0           |
| 79      | USR-Bridging               | UINT32 | 0-0           |
| 80      | USR-Spoofing               | UINT32 | 0-0           |
| 81      | USR-Host-Type              | String | 1-253         |
| 82      | USR-Send-Name              | UINT32 | 0-0           |
| 83      | USR-Send-Password          | String | 1-253         |
| 84      | USR-Start-Time             | UINT32 | 0-0           |
| 85      | USR-End-Time               | UINT32 | 0-0           |
| 86      | USR-Send-Script1           | String | 1-253         |
| 87      | USR-Reply-Script1          | String | 1-253         |

Table C-21 USR VSAs (continued)

| SubAttr | VSA Name                              | Type                                     | Min-Max Value |
|---------|---------------------------------------|------------------------------------------|---------------|
| 88      | USR-Send-Script2                      | String                                   | 1-253         |
| 89      | USR-Reply-Script2                     | String                                   | 1-253         |
| 90      | USR-Send-Script3                      | String                                   | 1-253         |
| 91      | USR-Send-Script3<br>USR-Reply-Script3 | String                                   | 1-253         |
| 92      | USR-Send-Script4                      | String                                   | 1-253         |
| 93      | USR-Reply-Script4                     | String                                   | 1-253         |
| 94      | USR-Send-Script5                      | String                                   | 1-253         |
| 95      | USR-Reply-Script5                     | String                                   | 1-253         |
| 96      | USR-Send-Script6                      | String                                   | 1-253         |
| 97      | USR-Reply-Script6                     | String                                   | 1-253         |
| 98      | USR-Terminal-Type                     | String                                   | 1-253         |
| 99      | USR-Appletalk-Network-Range           | UINT32                                   | 0-0           |
| 100     | USR-Local-IP-Address                  | String                                   | 1-253         |
| 101     | USR-Routing-Protocol                  | UINT32                                   | 0-0           |
| 102     | USR-Modem-Group                       | UINT32                                   | 0-0           |
| 103     | USR-IPX-Routing                       | UINT32                                   | 0-0           |
| 104     | USR-IPX-Wan                           | UINT32                                   | 0-0           |
| 105     | USR-IP-RIP-Policies                   | UINT32                                   | 0-0           |
| 106     | USR-IP-RIP-Simple-Auth-Password       | String                                   | 0-253         |
| 107     | USR-IDS0-Call-Type                    | UINT32                                   | 0-0           |
| 108     | USR-Call-Terminate-in-GMT             | UINT32                                   | 0-0           |
| 109     | USR-Call-Connect-in-GMT               | UINT32                                   | 0-0           |
| 110     | USR-Call-Arrival-in-GMT               | UINT32                                   | 0-0           |
| 111     | USR-Channel-Connected-To              | UINT32                                   | 0-0           |
| 112     | USR-Slot-Connected-To                 | UINT32                                   | 0-0           |
| 113     | USR-Device-Connected-To               | ENUM:<br>None<br>isdGateway<br>quadModem | 1-3           |
| 114     | USR-NFAS-ID                           | UINT32                                   | 0-0           |
| 115     | USR-Q931-Call-Reference-Value         | UINT32                                   | 0-0           |

Table C-21 USR VSAs (continued)

| SubAttr | VSA Name                   | Type                                                                                                                                                                                                                                                                                                                                                                                                                                                                           | Min-Max Value |
|---------|----------------------------|--------------------------------------------------------------------------------------------------------------------------------------------------------------------------------------------------------------------------------------------------------------------------------------------------------------------------------------------------------------------------------------------------------------------------------------------------------------------------------|---------------|
| 116     | USR-Call-Event-Code        | ENUM:<br>notSupported<br>noFreeIGW<br>igwRejectCall<br>igwSetupTimeout<br>noFreeTdmts<br>bcReject<br>ieReject<br>chidReject<br>progReject<br>callingPartyReject<br>calledPartyReject<br>setup<br>blocked<br>analogBlocked<br>digitalBlocked<br>outOfService<br>busy<br>congestion<br>protocolError<br>noFreeBchannel<br>inOutCallCollision<br>usrSetup<br>telcoDisconnect<br>usrDisconnect<br>noFreeModem<br>modemsNotAllowe<br>d<br>modemsRejectCall<br>modemSetupTimeo<br>ut | 1-28          |
| 117     | USR-DS0                    | UINT32                                                                                                                                                                                                                                                                                                                                                                                                                                                                         | 0-0           |
| 118     | USR-DS0s                   | String                                                                                                                                                                                                                                                                                                                                                                                                                                                                         | 1-253         |
| 119     | USR-Gateway-IP-Address     | IP Address                                                                                                                                                                                                                                                                                                                                                                                                                                                                     | 0-0           |
| 120     | USR-Physical-State         | UINT32                                                                                                                                                                                                                                                                                                                                                                                                                                                                         | 0-0           |
| 121     | USR-Chassis-Temp-Threshold | UINT32                                                                                                                                                                                                                                                                                                                                                                                                                                                                         | 0-0           |

Table C-21 USR VSAs (continued)

| SubAttr | VSA Name      | Type                                                                                                                                                                                                                                       | Min-Max Value |
|---------|---------------|--------------------------------------------------------------------------------------------------------------------------------------------------------------------------------------------------------------------------------------------|---------------|
| 122     | USR-Card-Type | ENUM:<br>SlotEmpty<br>QuadV32DigitalM<br>odemNAC<br>DualT1NIC<br>DualAlogMdmNIC<br>QuadDgtlMdmNIC<br>QuadAlogDgtlMd<br>mNIC<br>TokenRingNIC<br>SingleT1NIC<br>EthernetNIC<br>ShortHaulDualT1N<br>IC<br>DualAlogMgdIntl<br>MdmNIC<br>X25NIC |               |

Table C-21 USR VSAs (continued)

| SubAttr | VSA Name                  | Type                                                                                                                                                                                                                                                                                                                                                                                                                                                                                                                                                                                                                        | Min-Max Value |
|---------|---------------------------|-----------------------------------------------------------------------------------------------------------------------------------------------------------------------------------------------------------------------------------------------------------------------------------------------------------------------------------------------------------------------------------------------------------------------------------------------------------------------------------------------------------------------------------------------------------------------------------------------------------------------------|---------------|
| 122     | USR-Card-Type (continued) | ENUM:<br>QuadAlogNonMgdMdmNIC<br>QuadAlogMgdIntlMdmNIC<br>QuadAlogNonMgdIntlMdmNIC<br>QuadLsdLiMgdMdmNIC<br>QuadLsdLiNonMgdMdmNIC<br>QuadLsdLiMgdIntlMdmNIC<br>QuadLsdLiNonMgdIntlMdmNIC<br>EthernetWithV35NIC<br>HSEthernetWithoutV35NIC<br>DualHighSpeedV35NIC<br>QuadV35RS122LowSpeedNIC<br>DualE1NIC<br>ShortHaulDualE1NIC<br>BellcoreLongHaulDualT1NIC<br>BellcoreShrtHaulDualT1NIC<br>SCSIEdgeServerNIC<br>QuadV32AnalogModemNAC<br>QuadV32DigAnlModemNAC<br>QuadV34DigModemNAC<br>QuadV34AnlModemNAC<br>QuadV34DigAnlModemNAC<br>SingleT1NAC<br>EthernetGatewayNAC<br>AccessServer<br>486TrGatewayNAC<br>SlotUnknown |               |

Table C-21 USR VSAs (continued)

| SubAttr | VSA Name                  | Type                                                                                                                                                                                                                                                                                                                                                                       | Min-Max Value |
|---------|---------------------------|----------------------------------------------------------------------------------------------------------------------------------------------------------------------------------------------------------------------------------------------------------------------------------------------------------------------------------------------------------------------------|---------------|
| 122     | USR-Card-Type (continued) | ENUM:<br>486EthernetGatewayNAC<br>DualRS122NAC<br>486X25GatewayNAC<br>ApplicationServerNAC<br>ISDNGatewayNAC<br>ISDNpriT1NAC<br>ClkedNetMgtCard<br>ModemPoolManagementNAC<br>NetwMgtCard<br>ModemPoolNetserverNAC<br>(continued)                                                                                                                                           | 1-1027        |
| 122     | USR-Card-Type (continued) | ModemPoolV34ModemNAC<br>ModemPoolISDNNAC<br>NTServerNAC<br>QuadV34DigitalG2NAC<br>QuadV34AnalogG2NAC<br>QuadV34DigAnlgG2NAC<br>NETServerFrameRelayNAC<br>NETServerTokenRingNAC<br>X2524ChannelNAC<br>DualT1NAC<br>WirelessGatewayNac<br>EnhancedAccessServer<br>EnhancedISDNGatewayNAC<br>DualModemNAC<br>QuadModemNAC<br>TrGatewayNAC<br>X25GatewayNAC<br>DualV34ModemNAC |               |
| 112     | USR-Security-Login-Limit  | UINT32                                                                                                                                                                                                                                                                                                                                                                     | 0-0           |



Table C-21 USR VSAs (continued)

| SubAttr | VSA Name                     | Type                                                                                                                                                                                                                                                                                                                  | Min-Max Value |
|---------|------------------------------|-----------------------------------------------------------------------------------------------------------------------------------------------------------------------------------------------------------------------------------------------------------------------------------------------------------------------|---------------|
| 124     | USR-Security-Resp-Limit      | UINT32                                                                                                                                                                                                                                                                                                                | 0-0           |
| 125     | USR-Packet-Bus-Session       | UINT32                                                                                                                                                                                                                                                                                                                | 0-0           |
| 126     | USR-DTE-Ring-No-Answer-Limit | UINT32                                                                                                                                                                                                                                                                                                                | 0-0           |
| 127     | USR-Final-Rx-Link-Data-Rate  | ENUM:<br>110_BPS<br>14.4K_BPS<br>16.8_BPS<br>19.2K_BPS<br>38.4K_BPS<br>75_BPS<br>450_BPS<br>UNKNOWN_BPS<br>57.6K_BPS<br>21.6K_BPS<br>24K_BPS<br>300_BPS<br>6K_BPS<br>28K_BPS<br>115K_BPS<br>31K_BPS<br>33K_BPS<br>25333_BPS<br>26666_BPS<br>28000_BPS<br>62666_BPS<br>9333_BPS<br>30666_BPS<br>600_BPS<br>(continued) | 1-54          |

Table C-21 USR VSAs (continued)

| SubAttr | VSA Name                                   | Type                                                                                                                                                                                                                                                                                                                                                                                       | Min-Max Value |
|---------|--------------------------------------------|--------------------------------------------------------------------------------------------------------------------------------------------------------------------------------------------------------------------------------------------------------------------------------------------------------------------------------------------------------------------------------------------|---------------|
| 127     | USR-Final-Rx-Link-Data-Rate<br>(continued) | 32000_BPS<br>33333_BPS<br>34666_BPS<br>36000_BPS<br>37333_BPS<br>38666_BPS<br>40000_BPS<br>41333_BPS<br>42666_BPS<br>44000_BPS<br>1200_BPS<br>45333_BPS<br>46666_BPS<br>48000_BPS<br>49333_BPS<br>50666_BPS<br>52000_BPS<br>53333_BPS<br>54666_BPS<br>56000_BPS<br>57333_BPS<br>2400_BPS<br>58666_BPS<br>60000_BPS<br>61333_BPS<br>64000_BPS<br>800_BPS<br>7200_BPS<br>9600_BPS<br>12K_BPS |               |

Table C-21 USR VSAs (continued)

| SubAttr | VSA Name                      | Type                                                                                                                                                                                                                                                                                    | Min-Max Value |
|---------|-------------------------------|-----------------------------------------------------------------------------------------------------------------------------------------------------------------------------------------------------------------------------------------------------------------------------------------|---------------|
| 128     | USR-Initial-Rx-Link-Data-Rate | ENUM:<br>110_BPS<br>14.4K_BPS<br>16.8_BPS<br>19.2K_BPS<br>38.4K_BPS<br>75_BPS<br>450_BPS<br>UNKNOWN_BPS<br>57.6K_BPS<br>21.6K_BPS<br>24K_BPS<br>300_BPS<br>26K_BPS<br>28K_BPS<br>115K_BPS<br>31K_BPS<br>33K_BPS<br>25333_BPS<br>26666_BPS                                               | 1-54          |
| 128     | USR-Initial-Rx-Link-Data-Rate | 28000_BPS<br>29333_BPS<br>30666_BPS<br>600_BPS<br>32000_BPS<br>33333_BPS<br>34666_BPS<br>36000_BPS<br>37333_BPS<br>38666_BPS<br>40000_BPS<br>41333_BPS<br>42666_BPS<br>44000_BPS<br>1200_BPS<br>45333_BPS<br>46666_BPS<br>48000_BPS<br>49333_BPS<br>50666_BPS<br>52000_BPS<br>53333_BPS |               |

Table C-21 USR VSAs (continued)

| SubAttr | VSA Name                      | Type                                                                                                                                                             | Min-Max Value |
|---------|-------------------------------|------------------------------------------------------------------------------------------------------------------------------------------------------------------|---------------|
| 128     | USR-Initial-Rx-Link-Data-Rate | 54666_BPS<br>56000_BPS<br>57333_BPS<br>2400_XBPS<br>58666_BPS<br>60000_BPS<br>61333_BPS<br>62666_BPS<br>64000_BPS<br>4800_BPS<br>7200_BPS<br>9600_BPS<br>12K_BPS |               |
| 129     | USR-Event-Date-Time           | UINT32                                                                                                                                                           | 0-0           |
| 130     | USR-Chassis-Temperature       | UINT32                                                                                                                                                           | 0-0           |
| 131     | USR-Actual-Voltage            | UINT32                                                                                                                                                           | 0-0           |
| 132     | USR-Expected-Voltage          | UINT32                                                                                                                                                           | 0-0           |
| 133     | USR-Power-Supply-Number       | UINT32                                                                                                                                                           | 0-0           |
| 134     | USR-Channel                   | UINT32                                                                                                                                                           | 0-0           |
| 135     | USR-Chassis-Slot              | UINT32                                                                                                                                                           | 0-0           |

Table C-21 USR VSAs (continued)

| SubAttr | VSA Name     | Type                                                                                                                                                                                                                                                                                                                                                                                                                                                                                                                                                                                                                                                                                                                                                                                                                                     | Min-Max Value |
|---------|--------------|------------------------------------------------------------------------------------------------------------------------------------------------------------------------------------------------------------------------------------------------------------------------------------------------------------------------------------------------------------------------------------------------------------------------------------------------------------------------------------------------------------------------------------------------------------------------------------------------------------------------------------------------------------------------------------------------------------------------------------------------------------------------------------------------------------------------------------------|---------------|
| 136     | USR-Event-Id | ENUM:<br>HUB_Temp_Out_o<br>f_Range<br>Fan_Failed<br>Watchdog_Timeout<br>Mgmt_Bus_Failure<br>In_Connection_Est<br>Out_Connection_E<br>st<br>In_Connection_Ter<br>m<br>Out_Connection_T<br>erm<br>Connection_Failed<br>Connection_Timeo<br>ut<br>DTE_Transmit_Idl<br>e<br>DTR_True<br>DTR_False<br>Block_Error_at_Th<br>reshold<br>Fallbacks_at_Thres<br>hold<br>No_Dial_Tone_Det<br>ected<br>No_Loop_Current_<br>Detected<br>Yellow_Alarm<br>Red_Alarm<br>Loss_Of_Signal<br>Rcv_Alm_Ind_Sig<br>nal<br>Timing_Source_Sw<br>itch<br>Modem_Reset_by_<br>DTE<br>Modem_Ring_No_<br>Answer<br>DTE_Ring_No_An<br>swer<br>Pkt_Bus_Session_<br>Active<br>Pkt_Bus_Session_<br>Congestion<br>Pkt_Bus_Session_<br>Lost<br>Pkt_Bus_Session_I<br>nactive<br>User_Interface_Res<br>et<br>Gateway_Facility<br>_of_Service<br>Gateway_Port_Lin<br>k_Active |               |

Table C-21 USR VSAs (continued)

| SubAttr | VSA Name                          | Type                                                                                                                                                                                                                                                                                                                                                                                                                                                                                                                                                                                                                                                                                                                                                                                                                         | Min-Max Value |
|---------|-----------------------------------|------------------------------------------------------------------------------------------------------------------------------------------------------------------------------------------------------------------------------------------------------------------------------------------------------------------------------------------------------------------------------------------------------------------------------------------------------------------------------------------------------------------------------------------------------------------------------------------------------------------------------------------------------------------------------------------------------------------------------------------------------------------------------------------------------------------------------|---------------|
| 136     | USR-Event-Id ( <i>Continued</i> ) | Rcv_Alrm_Ind_Sig<br>nal_Clear<br>Incoming_Connecti<br>on_Establish<br>Module_Inserted<br>Outgoing_Connecti<br>on_Establish<br>Incoming_Connecti<br>on_Terminate<br>Outgoing_Connecti<br>on_Terminate<br>Connection_Attem<br>pt_Failure<br>Continuous_CRC_<br>Alarm<br>Continuous_CRC_<br>Alarm_Clear<br>Physical_State_Cha<br>nge<br>Module_Removed<br>Gateway_Network<br>_Failed<br>Gateway_Network<br>_Restored<br>Packet_Bus_Clock<br>_Lost<br>Packet_Bus_Clock<br>_Restored<br>D_Channel_In_Ser<br>vice<br>D_Channel_Out_of<br>_Service<br>DS0s_In_Service<br>DS0s_Out_of_Serv<br>ice<br>T1/T1PRI/E1PRI_<br>Call_Event<br>PSU_Voltage_Alarm<br>m<br>Psu_Incompatible<br>T1,T1-E1/PRI-Call<br>-Arrive-Even<br>T1,T1-E1/PRI-Call<br>-Connect-Eve<br>T1,T1-E1/PRI-Call<br>-Termina-Eve<br>T1,T1-E1/PRI-Call<br>-Failed-Even | 6-84          |

Table C-21 USR VSAs (continued)

| SubAttr | VSA Name                         | Type                                                                                                                                                                                                                                                | Min-Max Value |
|---------|----------------------------------|-----------------------------------------------------------------------------------------------------------------------------------------------------------------------------------------------------------------------------------------------------|---------------|
| 137     | USR-Number-of-Rings-Limit        | UINT32                                                                                                                                                                                                                                              | 0-0           |
| 138     | USR-Connect-Time-Limit           | UINT32                                                                                                                                                                                                                                              | 0-0           |
| 139     | USR-Call-End-Date-Time           | UINT32                                                                                                                                                                                                                                              | 0-0           |
| 140     | USR-Call-Start-Date-Time         | UINT32                                                                                                                                                                                                                                              | 0-0           |
| 141     | USR-Server-Time                  | UINT32                                                                                                                                                                                                                                              | 0-0           |
| 142     | USR-Request-Type                 | ENUM:<br>Access-Request<br>Access-Challenge<br>Status-Server<br>Status-Client<br>Access-Accept<br>Reserved<br>Access-Reject<br>Accounting-Request<br>Accounting-Response<br>Access-Password-Change<br>Access-Password-Ack<br>Access-Password-Reject | 1-255         |
| 143     | USR-Old-Password                 | String                                                                                                                                                                                                                                              | 0-253         |
| 144     | USR-Expiration                   | UINT32                                                                                                                                                                                                                                              | 0-0           |
| 145     | USR-Prompt                       | UINT32                                                                                                                                                                                                                                              | 0-1           |
| 146     | USR-Char-Noecho                  | UINT32                                                                                                                                                                                                                                              | 0-0           |
| 147     | USR-User-Group-Name              | String                                                                                                                                                                                                                                              | 0-253         |
| 148     | 148<br>USR-Call-Reference-Number | UINT32                                                                                                                                                                                                                                              | 0-253         |
| 149     | USR-Dial-In-Sec-Mode             | UNIT32                                                                                                                                                                                                                                              | 0-0           |
| 150     | USR-Req-Db-Mdm-Sel               | UINT32                                                                                                                                                                                                                                              | 0-0           |
| 151     | USR-Req-Db-Login-Valid           | UINT32                                                                                                                                                                                                                                              | 0-0           |
| 152     | USR-Dialback-Group-Names         | String                                                                                                                                                                                                                                              | 0-253         |
| 153     | USR-Dial-In-Call-Rest            | String                                                                                                                                                                                                                                              | 0-253         |
| 154     | USR-Dial-Out-Call-Rest           | String                                                                                                                                                                                                                                              | 0-253         |
| 155     | USR-Logins-Before-Blacklist      | UINT32                                                                                                                                                                                                                                              | 0-0           |
| 156     | USR-Failed-Logins                | UINT32                                                                                                                                                                                                                                              | 0-0           |
| 157     | USR-Allowed-DB-Modems            | String                                                                                                                                                                                                                                              | 0-253         |
| 158     | USR-VPN-Encrypter                | String                                                                                                                                                                                                                                              | 0-253         |

Table C-21 USR VSAs (continued)

| SubAttr | VSA Name                       | Type                                                                          | Min-Max Value |
|---------|--------------------------------|-------------------------------------------------------------------------------|---------------|
| 159     | USR-Acct-VPN-Gateway           | String                                                                        | 0-253         |
| 160     | USR-Re-CHAP-Timeout            | UINT32                                                                        | 0-0           |
| 161     | USR-RMMIE-Manufacture-ID       | String                                                                        | 0-253         |
| 162     | USR-RMMIE-Product-Code         | String                                                                        | 0-253         |
| 163     | USR-RMMIE-Serial-Number        | String                                                                        | 0-253         |
| 164     | USR-RMMIE-Firmware-Version     | String                                                                        | 0-253         |
| 165     | USR-RMMIE-Firmware-Build-Date  | String                                                                        | 0-253         |
| 166     | USR-RMMIE-Status               | ENUM:<br>notEnabledInLocalModem<br>notDetectedInRemoteModem<br>ok             | 1-3           |
| 170     | USR-RMMIE-Last-Update-Time     | UINT32                                                                        | 0-253         |
| 171     | USR-RMMIE-Last-Update-Event    | ENUM:<br>None<br>initialConnection<br>retrain speedShift<br>plannedDisconnect | 1-5           |
| 172     | USR-RMMIE-Rcv-Tot-PwrLvl       | UNIT32                                                                        | 0-253         |
| 173     | USR-RMMIE-Rcv-PwrLvl-3300Hz    | UNIT32                                                                        | 0-253         |
| 174     | USR-RMMIE-Rcv-PwrLvl-3750Hz    | UNIT32                                                                        | 0-253         |
| 175     | USR-RMMIE-PwrLvl-NearEcho-Canc | UNIT32                                                                        | 0-253         |
| 176     | USR-RMMIE-PwrLvl-FarEcho-Canc  | UNIT32                                                                        | 0-253         |
| 177     | USR-RMMIE-PwrLvl-Noise-Lvl     | UNIT32                                                                        | 0-253         |
| 178     | USR-RMMIE-PwrLvl-Xmit-Lvl      | UNIT32                                                                        | 0-253         |
| 179     | USR-IPX-SAP                    | String                                                                        | 0-253         |
| 180     | USR-MIC                        | UNIT32                                                                        | 0-253         |
| 181     | USR-Call-Tracking-ID           | UNIT32                                                                        | 0-253         |
| 182     | USR-Log-Filter-Packet          | UNIT32                                                                        | 0-253         |
| 183     | USR-CCP-Algorithm              | UNIT32                                                                        | 0-253         |



Table C-21 USR VSAs (continued)

| SubAttr | VSA Name                         | Type   | Min-Max Value |
|---------|----------------------------------|--------|---------------|
| 184     | USR-ACCM-Type                    | UNIT32 | 0-253         |
| 185     | USR-Connect-Speed                | UNIT32 | 0-253         |
| 186     | USR-Framed-IP-Address-Pool-Name  | UNIT32 | 0-253         |
| 187     | USR-MP-EDO                       | String | 0-253         |
| 188     | USR-Local-Framed-IP-Addr         | UNIT32 | 0-253         |
| 189     | USR-IP-RIP-Input-Filter          | String | 0-253         |
| 190     | USR-IP-Call-Input-Filter         | String | 0-253         |
| 191     | USR-IPX-Call-Input-Filter        | String | 0-253         |
| 192     | USR-AT-Input-Filter              | String | 0-253         |
| 193     | USR-AT-RTMP-Input-Filter         | String | 0-253         |
| 194     | USR-AT-Zip-Input-Filter          | String | 0-253         |
| 195     | USR-AT-Call-Input-Filter         | String | 0-253         |
| 196     | USR-ET-Bridge-Input-Filter       | String | 0-253         |
| 197     | USR-IP-RIP-Output-Filter         | String | 0-253         |
| 198     | USR-IP-Call-Output-Filter        | String | 0-253         |
| 199     | USR-IPX-RIP-Output-Filter        | String | 0-253         |
| 200     | USR-IPX-Call-Output-Filter       | String | 0-253         |
| 201     | USR-AT-Output-Filter             | String | 0-253         |
| 202     | USR-ET-RTMP-Output-Filter        | String | 0-253         |
| 203     | USR-AT-Zip-Output-Filter         | String | 0-253         |
| 204     | USR-AT-Call-Output-Filter        | String | 0-253         |
| 205     | USR-ET-Bridge-Output-Filter      | String | 0-253         |
| 206     | USR-ET-Bridge-Call-Output-Filter | String | 0-253         |
| 207     | USR-IP-Default-Route-Option      | UINT32 | 0-253         |
| 208     | USR-MP-EDO-HIPER                 | String | 0-253         |
| 209     | USR-MP-MRRU                      | UINT32 | 0-253         |

## WiMax

Table C-22 lists the WiMax VSAs. The vendor ID for WiMax VSAs is 24757.

**Table C-22** WiMax VSAs

| SubAttr | VSA Name             | Type      | Min-Max Value |
|---------|----------------------|-----------|---------------|
| 1       | HA-IP-MIP4           | IPAddress | 0-253         |
| 2       | HA-IP-MIP6           | IPAddress | 0-253         |
| 3       | GMT-Time-Zone-Offset | String    | 0-253         |
| 4       | NAP-ID               | String    | 0-253         |
| 5       | NSP-ID               | String    | 0-253         |
| 6       | Hotline-Indicator    | String    | 0-253         |
| 7       | BS-ID                | String    | 0-253         |

## WISPr

Table C-23 lists the WISPr VSAs. The vendor ID for WISPr VSAs is 14122.

**Table C-23** WISPr VSAs

| SubAttr | VSA Name                           | Type   | Min-Max Value |
|---------|------------------------------------|--------|---------------|
| 1       | WISPr-Location-ID                  | String | 0-65535       |
| 2       | WISPr-Location-Name                | String | 0-253         |
| 3       | WISPr-Logoff-URL                   | String | 0-253         |
| 4       | WISPr-Redirection-URL              | String | 0-253         |
| 5       | WISPr-Bandwidth-Min-Up             | UINT32 | 0-65535       |
| 6       | WISPr-Bandwidth-Min-Down           | UINT32 | 0-65535       |
| 7       | WISPr-Bandwidth-Max-Up             | UINT32 | 0-65535       |
| 8       | WISPr-Bandwidth-Max-Down           | UINT32 | 0-65535       |
| 9       | WISPr-Session-Terminate-Time       | UINT32 | 0-65535       |
| 10      | WISPr-Session-Terminate-End-Of-Day | UINT32 | 0-65535       |
| 11      | WISPr-Billing-Class-Of-Service     | String | 0-253         |

## XML

Table C-24 lists the XML VSAs, attributes for XML tags. The vendor ID for XML VSAs is 5842.

**Table C-24 XML VSAs**

| SubAttr | VSA Name                         | Type   | Min-Max Value |
|---------|----------------------------------|--------|---------------|
| 1       | XML-Address-format-IPv4          | IPADDR | 0-253         |
| 2       | XML-Association                  | String | 0-253         |
| 3       | XML-Request                      | String | 0-253         |
| 4       | XML-Response                     | String | 0-253         |
| 5       | XML-UserId-id_type-subscriber_id | String | 0-253         |
| 6       | XML-UserIdRequest                | String | 0-253         |





## GLOSSARY

---

### A

- Access point** A device that bridges the wireless link on one side to the wired network on the other.
- Analog Channel** A circuit-switched communication path intended to carry 3.1 KHz audio in each direction.
- ARP** Address Resolution Protocol is the TCP/IP protocol that translates an Internet address into the hardware address of a network interface card.
- ATM** Asynchronous Transfer Mode is a virtual circuit, fast packet technology. Traffic of all kinds (data, voice, video) is divided into 53-byte cells and conducted over very high speed media.
- ATO** Adaptive TimeOut is the time that must elapse before an acknowledgment is considered lost. After a timeout, the sliding window is partially closed and the ATO is backed off.

---

### C

- Call** A connection or attempted connection between two terminal end points on a PSTN or ISDN; for example, a telephone call between two modems.
- CHAP** Challenge Authentication Protocol is a PPP cryptographic challenge/response authentication protocol in which the clear text password is not passed in the clear over the line.
- CLID** Calling Line ID indicates to the receiver of a call, the phone number of the caller.
- CM** Cable Modem is usually a modem with an RF (cable) interface on one side and an Ethernet interface on the other. A cable modem might also have a telephone interface for “telco return,” which is used when only downstream capability exists in the cable plant.
- CNR** Cisco Network Registrar—A network management application which includes a DHCP server and a DNS server.
- Community String** A string used to authenticate the trap message sender (SNMP agent) to the trap recipient (SNMP management station).
- Control Messages** Control messages are exchanged between LAC, LNS pairs, and operate in-band within the tunnel protocol. Control messages govern aspects of the tunnel and sessions within the tunnel.
- CSG** Cable Systems Group is a billing systems company.
- CSR** Customer Service Representative—the person you call to activate or obtain service for your account.

---

**C**

- CSU/DSU** Channel Service Unit/Data Service Unit isolates your network from your exchange carrier's network. It also receives the timing, low-level framing information, and data passed from the termination point. CSU/DSUs are specific to the general circuit type.
- Customer** A user of an ISP or an enterprise. The provider offers the customer MPLS VPN service. The enterprise provides the customer remote user access to various sites. In the case of ISPs, MPLS BPN provides a scalable wholesale access/open access solution.

---

**D**

- DAP** Directory Access Protocol is a heavyweight protocol that runs over a full OSI stack and requires a significant amount of computing resources to run.
- Data Source** Sets of data and their associated environments which include operating system, DBMS, and network platforms used to access the DBMS that an application wants to access.
- DHCP** Dynamic Host Configuration Protocol—a protocol that describes the service of providing and managing IP addresses to clients on a network.
- DHCP Client** The IOS DHCP client used to generate requests for host addresses and subnets for non-PPP clients.
- DHCP Proxy Client** The IOS DHCP client used to request an address for a PPP user from a DHCP server.
- Dial Use** Dial Use is an end-system or router attached to an on-demand PSTN or ISDN, which is either the initiator or recipient of a call.
- Digital Channel** Digital Channel is a circuit-switched communication path that is intended to carry digital information in each direction.
- DNIS** Dialed Number Information String is an indication to the receiver of a call as to what phone number the caller used to reach it.
- Driver Manager** A special library that manages communication between applications and drivers. Applications call ODBC API functions in the driver managers which load and call one or more drivers on behalf of the applications.

---

**E**

- EAP** Extensible Authentication Protocol is a framework for a family of PPP authentication protocols, including cleartext, challenge/response, and arbitrary dialog sequences.

---

**F**

- FT** Field Technician is someone who installs your cable modem in your house.
- Frame Relay** Frame Relay is a cost-effective, lightweight, many-to-many, medium-speed, virtual network, link-layer technology.

---

**G**

- GGSN** GPRS Gateway Support Node, a network node that acts as a gateway between a GPRS wireless data network and other networks such as the Internet or a private network.
- GPRS** General Packet Radio Service, a mobile data service available to users of GSM and IS-136 mobile phones.

---

**I**

- ISDN** Integrated Services Digital Network enables synchronous PPP access.
- ISP** Internet Service Provider is a company that provides Internet connectivity.

---

**H**

- HDLC** High-level Data Link Control is both a point-to-point and multiparty link-layer technology. HDLC provides reliable, acknowledged transfer across dedicated links.

---

**L**

- L2TP Access Concentrator (LAC)** LAC is a device attached to one or more PSTN or ISDN lines capable of PPP operation and of handling the L2TP protocol. The LAC needs only to implement the media over which L2TP is to operate to pass traffic to one or more LNSs. It might tunnel any protocol carried within PPP.
- LAN** Local Area Network consists of all of the components that create a system up to a router. These components include cables, repeaters, bridges, and software up to the network layer.
- LDAP** Lightweight Directory Access Protocol provides a standard way for Internet clients, applications, and WWW servers to access directory information across the Internet such as usernames, e-mail addresses, security certificates, and other contact information.
- LEAP** Light Extensible Authentication Protocol—

---

**L**

- LLC** Logical Link Control is an interface that defines several common interfaces between higher-level protocols (for example, IP) and the networks they ride upon (for example, Ethernet, Token Ring, and others).
- L2TP Network Server (LNS)** An LNS operates on any platform capable of PPP termination. The LNS handles the server side of the L2TP protocol. Since L2TP relies only on the single media over which L2TP tunnels arrive, the LNS can have only a single LAN or WAN interface, yet still be able to terminate calls arriving at any LAC's full range of PPP interfaces (async, synchronous ISDN, V.120, etc.).

---

**M**

- MIB** Management Information Base—Database of network management information used and maintained by a network management protocol such as SNMP. The value of a MIB object can be changed or retrieved using SNMP commands. MIB objects are organized in a tree structure that includes public and private branches.
- MPLS** Multi-Protocol Label Switching—
- MPLS VPN** MPLS-based Virtual Private Networks
- MSO** Multiple System Operators are typically cable companies that provide Internet access for regional independent operators.

---

**N**

- NAS** Network Access Server is a device providing temporary, on-demand network access to users. This access is point-to-point using PSTN or ISDN lines. A NAS operates as a client of RADIUS. The client is responsible for passing user information to designated RADIUS servers.
- In PPTP terminology, this is referred to as the PPTP Access Concentrator (PAC). In L2TP terminology, the NAS is referred to as the L2TP Access Concentrator (LAC).
- NCP** Network Control Protocol is responsible for negotiating the protocol-specific particulars of the point-to-point protocol (PPP) link.
- Network Access Identifier** In order to provide for the routing of RADIUS authentication and accounting requests, the UserID field used in PPP and in the subsequent RADIUS authentication and accounting requests, known as the Network Access Identifier (NAI), might contain structure. This structure provides a means by which the RADIUS proxy locates the RADIUS server that is to receive the request. This same structure can also be used to locate the tunnel end point when domain-based tunneling is used.



---

**O**

- ODBC** Open Database Connectivity—a standard set of application programming interface (API) function calls (supported by Microsoft and in general use) that can be used to access data store in both relational and non-relational database management systems (DBMSs).
- ODBC Driver** Processes ODBC function calls, submits SQL requests to specific data source, and returns results to applications. ODBC drivers for specific types of data files, including database files, spreadsheet files, and text fields, are available from Microsoft Corporation.

---

**P**

- packet** A block of data in a standard format for transmission.
- PAP** Password Authentication Protocol is a simple PPP authentication mechanism in which a cleartext username and password are transmitted to prove identity.
- Payload** The contents of a request packet.
- PDU** Protocol Data Unit—An SNMP compliant request, response, or trap message.
- PE Router** Provider Edge router—a router located at the edge of the provider’s MPLS core network.
- POP** Point of Presence is the dial-in point or connection point for users connecting to an ISP.
- PPD** Packet Processing Delay is the amount of time required for each peer to process the maximum amount of data buffered in their offered receive packet window. The PPD is the value exchanged between the LAC and LNS when a call is established. For the LNS, this number should be small. For an LAC supporting modem connections, this number could be significant.
- PPP** Point-to-Point Protocol—a multiprotocol and includes UDP, Frame Relay PVC, and X.25 VC.
- Profile** A collection of one or more attributes that describe how a user should be configured; for example, a profile can contain an attribute whose value specifies the type of connection service to provide the user, such as PPP, SLIP, or Telnet. Profiles can be set up for a specific user or can be shared amongst users.
- Provider** Service Provider—A provider who operates the access networks and MPLS backbone and provides MPLS VPN service on the backbone.
- PSTN** Public Switched Telephone Network enables async PPP through modems.

---

**Q**

- Quality of Service (QoS)** A given Quality of Service level is sometimes required for a given user being tunneled between an LNS-LAC pair. For this scenario, a unique L2TP tunnel is created (generally on top of a new SVC) and encapsulated directly on top of the media providing the indicated QoS.

---

**R**

|                           |                                                                                                                                                                                                                                                                                                                                                                                                                                                                                                             |
|---------------------------|-------------------------------------------------------------------------------------------------------------------------------------------------------------------------------------------------------------------------------------------------------------------------------------------------------------------------------------------------------------------------------------------------------------------------------------------------------------------------------------------------------------|
| <b>RAC Client</b>         | The IOS DHCP client used to generate requests for host addresses and subnets for non-PPP clients.                                                                                                                                                                                                                                                                                                                                                                                                           |
| <b>RADIUS</b>             | Remote Authentication Dial-In User Service. The RADIUS protocol provides a method that allows multiple dial-in Network Access Server (NAS) devices to share a common authentication database.                                                                                                                                                                                                                                                                                                               |
| <b>RADIUS Client</b>      | A Network Access Server (NAS) operates as a client of RADIUS. The client is responsible for passing user information to designated RADIUS servers, and then acting on the response that is returned. A RADIUS server can act as a proxy client to other RADIUS servers.                                                                                                                                                                                                                                     |
| <b>RADIUS Dictionary</b>  | The RADIUS dictionary passes information between a script and the RADIUS server, or between scripts running on a single packet.                                                                                                                                                                                                                                                                                                                                                                             |
| <b>RADIUS Proxy</b>       | In order to provide for the routing of RADIUS authentication and accounting requests, a RADIUS proxy might be employed. To the NAS, the RADIUS proxy appears to act as a RADIUS server, whereas to the RADIUS server the proxy appears to act as a RADIUS client.                                                                                                                                                                                                                                           |
| <b>RADIUS Server</b>      | A server that is responsible for receiving user connection requests, authenticating the user, and then returning all of the configuration information necessary for the client to deliver the service to the user.                                                                                                                                                                                                                                                                                          |
| <b>RAS</b>                | Remote Access Services. See RADIUS Client.                                                                                                                                                                                                                                                                                                                                                                                                                                                                  |
| <b>Remote DHCP Server</b> | Usually a DHCP server in the service provider's networks, however it might also be a DHCP server in the customer's VPN.                                                                                                                                                                                                                                                                                                                                                                                     |
| <b>Remote Server</b>      | A server that has been registered with the user interface, which can later be referenced as a proxy client or as the method to perform a service; for example, a remote RADIUS server can be specified to act as a proxy client.                                                                                                                                                                                                                                                                            |
| <b>REX</b>                | RADIUS EXtension allows you to write C and C++ programs to affect the behavior of Cisco Prime AR.                                                                                                                                                                                                                                                                                                                                                                                                           |
| <b>Roaming</b>            | The ability to connect to a NAS that is not your normal POP (Point of Presence) and have the Access-Request redirected to your normal RADIUS server. The ability to use any one of multiple Internet server providers, while maintaining a formal, customer-vendor relationship with only one.                                                                                                                                                                                                              |
| <b>Router</b>             | A network device that connects multiple network segments and forwards packets from one network to another. The router must determine how to forward a packet based on addresses, network traffic, and cost.                                                                                                                                                                                                                                                                                                 |
| <b>Routing Tables</b>     | A table that lists all of the possible paths data can take to get from a source to a destination. Depending on how routers are configured, they can build their tables dynamically by trading information with other routers, or they can be statically configured in advance.                                                                                                                                                                                                                              |
| <b>RTT</b>                | Round-Trip Time is the estimated round-trip time for an Acknowledgment to be received for a given transmitted packet. When the network link is a local network, this delay will be minimal (if not zero). When the network link is the Internet, this delay could be substantial and vary widely. RTT is adaptive; it adjusts to include the PPD (Packet Processing Delay) and whatever shifting network delays contribute to the time between a packet being transmitted and receiving its acknowledgment. |

---

**S**

|                           |                                                                                                                                                                                                                                                                                                                                                                                                                                                                                                                                       |
|---------------------------|---------------------------------------------------------------------------------------------------------------------------------------------------------------------------------------------------------------------------------------------------------------------------------------------------------------------------------------------------------------------------------------------------------------------------------------------------------------------------------------------------------------------------------------|
| <b>SAP</b>                | Service Access Points (source and destination) identify protocols from which a packet has come and to which a packet must be delivered.                                                                                                                                                                                                                                                                                                                                                                                               |
| <b>Script</b>             | Instructions that are run in the context of a RADIUS client/server session. Scripts can be specified for servers, clients, vendors, and services. A script can be used as an incoming script, an outgoing script, or both. Incoming scripts are executed during the Access-Request portion of a dial-in session. Outgoing scripts are executed during the Access-Accept portion of a dial-in session. Scripts are referenced within the User Interface by name. Scripts can be source code for a scripting language or a binary file. |
| <b>Service</b>            | A means of specifying the method to use to perform a function. A service can be specified for the following functions: authentication, authorization, accounting, and authentication-authorization. For example, a service can specify that authentication be performed using the local database, or a service can specify that accounting be supported by logging information to a file.                                                                                                                                             |
| <b>Services</b>           | Three default services are referenced by the server configuration and when processing scripts. They are Default Authentication Service, Default Authorization Service, and Default Accounting Service. Each service has a type and (if it is using remote servers) an ordered list of servers to use.                                                                                                                                                                                                                                 |
| <b>Session</b>            | Each service provided by the NAS to a dial-in user constitutes a session, with the beginning of the session defined as the point where service is first provided and the end of the session defined as the point where service is ended. Depending on NAS support capabilities, a user can have multiple sessions in parallel or in series.                                                                                                                                                                                           |
| <b>SHA-1</b>              | Secure Hash Algorithm; a hashing algorithm that produces a 160-bit digest based upon the input. The algorithm produces SHA passwords that are irreversible or prohibitively expensive to reverse.                                                                                                                                                                                                                                                                                                                                     |
| <b>Shared Secret</b>      | Used to authenticate transactions between the client and the RADIUS server. The shared secret is never sent over the network.                                                                                                                                                                                                                                                                                                                                                                                                         |
| <b>Shared Use Network</b> | An IP dial-up network whose use is shared by two or more organizations. Shared use networks typically implement distributed authentication and accounting in order to facilitate the relationship amongst the sharing parties.                                                                                                                                                                                                                                                                                                        |
| <b>Silently Discard</b>   | RADIUS discards the packet without further processing. The server logs an error, including the contents of the silently discarded packet, and records the event in a statistics counter.                                                                                                                                                                                                                                                                                                                                              |
| <b>SLIP</b>               | Serial Line Internet Protocol is TCP/IP over direct connections and modems, which allows one computer to connect to another or to a whole network.                                                                                                                                                                                                                                                                                                                                                                                    |
| <b>SMDS</b>               | Switched Multi-megabit Data Service is a high-speed Metropolitan-Area Networking technology that behaves like a LAN.                                                                                                                                                                                                                                                                                                                                                                                                                  |
| <b>SSHA</b>               | Netscape's (iPlanet) enhancement of the SHA-1 algorithm which includes <i>salted</i> password data.                                                                                                                                                                                                                                                                                                                                                                                                                                   |
| <b>SNAP</b>               | SubNetwork Access Protocol is used when a SAP definition does not exist for the encapsulated user data protocol.                                                                                                                                                                                                                                                                                                                                                                                                                      |

---

**S**

- SSL** Secure Socket Layer is the protocol defined by Netscape that is used for encryption and authentication between two Internet entities. It uses public/private key certificates instead of shared secrets.
- SVC** Switched Virtual Circuit is an L2TP-compatible media on top of which L2TP is directly encapsulated. SVCs are dynamically created, permitting tunnel media to be created dynamically in response to desired LNS-LAC connectivity requirements.

---

**T**

- TACACS** Terminal Access Controller Access Control System, a an authentication server that validates user IDs and passwords, thus controlling entry into systems.
- Telnet** A service that lets you log in to a system over a network just as though you were logging in from a remote character terminal attached to the system. It is commonly used to provide an Internet service that is exactly the same as the one you would get if you dialed into the system directly with a modem.
- Trap** A network message of a specific format issued by an SNMP entity on behalf of a network management agent application. A trap is used to provide the management station with an asynchronous notification of an event.
- Tunnel** A tunnel is defined by an LNS-LAC pair. The tunnel carries PPP datagrams between the LAC and the LNS; many sessions can be multiplexed over a single tunnel. A control connection operating in band over the same tunnel controls the establishment, release, and maintenance of sessions and of the tunnel itself.
- Tunnel Network Server** A server that terminates a tunnel. In PPTP terminology, this is known as the PPTP Network Server (PNS). In L2TP terminology, this is known as the L2TP Network Server (LNS).

---

**U**

- UDP** User Datagram Protocol, a data packet protocol.
- User List** The list of users registered for dial-in access.
- User Record** The UserRecord contains all the information that needs to be accessed at runtime about a particular user. This enables it to be read in one database operation in order to minimize the cost of authenticating the user. The UserRecord is stored as an encrypted string in the MCD database, because it contains the user's password, amongst other things.
- Users** Users are represented by entities in specific UserLists. See User Record.

---

**V**

- Vendor** Each NAS has a vendor associated with it. A vendor can specify attributes for the NAS that are not part of the standard specification.
- VHG** Virtual Home Gateway—a Cisco IOS component that terminates PPP sessions. It is owned and managed by the service provider on behalf of its customer to provide access to remote users of that customer's network. A single service provider device (router) can host multiple VHGs of different customers. A VHG can be dynamically brought up and down based on the access pattern of the remote users. Note that there is no single IOS feature called the VHG; it is a collection of function and features (PPP, virtual profiles, VRFs, etc.).
- VPN** Virtual Private Network is a way for companies to use the Internet to securely transport private data.
- VRF** Virtual routing and forwarding. A per VPM routing table on the PE router. Each VPN instantiated on that PE router has its own VRF.

---

**W**

- WAP** Wireless Application Protocol; an application environment and set of communication protocols for wireless devices designed to enable manufacturer-, vendor-, and technology-independent access to the Internet and advanced telephony services.
- WPS** Wireless Provisioning Service; provides a standards-based and integrated platform to simply provision and manage their Wi-Fi hot spots. WPS allows users of Windows XP to connect to Wi-Fi hot spots with a seamless sign-up process and enables a more secure wireless network access.

---

**X**

- X.25** A reliable public data network technology consisting of private virtual circuits, virtual calling, and per-packet charging.
- X.500** Defines the Directory Access Protocol (DAP) for clients to use when contacting directory servers. DAP is a heavyweight protocol that runs over a full OSI stack and requires a significant amount of computing resources to run.





## INDEX

---

### Symbols

/bin/arserver [17-4](#)

---

### A

AAAFileServiceSyncInterval [4-60](#)

AcceptAll [3-22, 4-12, 4-14, 4-16, 4-17, 4-18, 4-19, 4-24](#)

Accepted-Profiles [B-1](#)

Access-Challenge [1-12](#)

Access Registrar

    definition [1-1](#)

    dictionaries [11-1](#)

    internal database [25-1](#)

    objects [1-2, 4-3](#)

    server [3-10, 4-2](#)

Access-Reject [B-12](#)

Access-Request [5-2, 5-7, 5-8](#)

Accounting [7-1](#)

    attributes [1-15](#)

    database [1-1](#)

    definition [1-1](#)

    log file [3-20, 4-14](#)

    MaxFileAge [7-2](#)

    MaxFileAge format [7-4](#)

    MaxFileSize [7-2](#)

    MaxFileSize format [7-3](#)

    RolloverSchedule [7-2](#)

    setting up [7-2](#)

    Start [7-1](#)

    Stop [7-1](#)

Accounting records [16-10](#)

Accounting-Service [B-2](#)

ACKaccounting [4-58](#)

Acquire-Dynamic-DNS [B-2](#)

Acquire-Home-Agent [B-2](#)

addProfile method [A-2](#)

AdvancedDuplicateDetectionMemoryInterval [4-62, 4-72](#)

agent\_server\_logs [28-3](#)

AllowEAPRejectAttrs [4-66](#)

AllowRejectAttrs [4-66](#)

AltigaOutgoingScript [11-8](#)

ANAAAOutgoing [11-8](#)

APPEND [A-2, A-5, A-8, A-9, A-10](#)

arbug [17-32, 17-33](#)

aregcmd

    Cisco Prime Access Registrar command [2-1](#)

    command performance [2-3](#)

    commands [2-4, 2-17](#)

        add [2-5](#)

        cd [2-5](#)

        delete [2-6](#)

        exit [2-6](#)

        filter [2-6](#)

        find [2-6](#)

        help [2-7](#)

        insert [2-7](#)

        login [2-7](#)

        logout [2-7](#)

        ls [2-8](#)

        next [2-8](#)

        prev [2-8](#)

        pwd [2-8](#)

        query-sessions [2-9](#)

        quit [2-9](#)

        release-sessions [2-9](#)

- reload [2-10](#)
- save [2-10](#)
- set [2-11](#)
- start [2-12](#)
- stats [2-12](#)
- status [2-14](#)
- stop [2-14](#)
- trace [2-15](#)
- unset [2-16](#)
- validate [2-17](#)
- definition [2-1](#)
- error codes [2-19](#)
- save [6-4](#)
- session management commands [4-34](#)
- syntax [2-1](#)

ARIsCaseInsensitive [4-64](#)

arserver file [17-4](#)

AscendIncomingScript [11-8](#)

AscendOutgoingScript [11-8](#)

Attribute Dictionary [1-15, 4-75, A-1](#)

- methods [A-1](#)

- put method [A-3](#)

Attributes [4-44, C-1](#)

- alphabetical list [C-1](#)

- check item [17-34](#)

- numeric list [C-4](#)

AttributesToBeReturned [17-7](#)

AUGMENT [A-2, A-3, A-8, A-9](#)

Authentication-Service [1-7](#)

Authorization

- definition [1-1](#)

Authorization-Service [1-7](#)

---

## B

BackingStoreDiscThreshold [3-69, 3-107, 4-56, 4-60, 4-71, 21-13](#)

BackingStore-Env-Vars [B-4](#)

BaseProfile [3-13, 4-4, 4-5](#)

BindName [4-50](#)

BindPassword [4-50](#)

Broadcast-Accounting-Packet [B-4](#)

---

## C

CabletronOutgoing [11-9](#)

Cache-Attributes-In-Session [B-4](#)

Callback-Number [1-15](#)

callsPerSecond [5-11](#)

Case insensitive commands

- see also [aregcmd](#)

cd command [2-1](#)

CertificateDBPath [4-61](#)

change directory command

- see also [aregcmd](#)

Change of Authorization (CoA) [17-39](#)

CHAP

- Access Request packet [5-3](#)

CHAP\_ PASSWORD

- attribute type [4-75](#)

Check item attributes [17-34](#)

CIDR notation [3-92, 4-6](#)

CiscoIncoming [11-9](#)

CiscoOutgoing [11-9](#)

Cisco Prime Access Registrar

- backups [25-1](#)

Cisco Subscriber Edge Services Manager [15-1](#)

CiscoWithODAPIncomingScript [11-9, 13-1, 13-3](#)

Classless Inter-Domain Routing [3-92, 4-6](#)

ClassName [4-11](#)

clear method [A-2](#)

Client/server model [1-12](#)

Client-Behind-the-Proxy [11-2](#)

Clients

- IPAddress [3-92, 4-6](#)

- list [4-71](#)

- vendor properties [3-92, 4-7](#)

CoA requests [17-39](#)



## Commands

- eap-trace [9-41](#)
- tunnel [9-41](#)
- config\_mcd\_server\_logs [28-3](#)
- ConfigurationError reply message [4-74](#)
- Configuration Examples
  - Query-Notify feature [17-8](#)
- Configuration Objects [2-3](#)
- Configuring
  - check item attributes [17-34](#)
  - LDAP RemoteServer [20-3](#)
  - local service [6-2](#)
  - ODBC RemoteServer [21-7](#)
- Configuring CoA requests [17-39](#)
- Configuring rules [18-2](#)
- containsKey method [A-2](#)
- CRB-Prepaid billing
  - with SSG [16-15](#)

## D

- Database
  - Cisco Prime Access Registrar backups [25-1](#)
  - MCD [6-4](#)
- DataSourceConnections [4-51](#)
- DDNS [4-66](#)
- DefaultAccountingService [3-11, 4-3](#)
- DefaultAuthenticationService [1-4, 3-11, 4-3](#)
- DefaultAuthorizationService [3-11, 4-3](#)
- DefaultReturnedSubnetSizeIfNoMatch [4-63](#)
- DefaultSessionManager [3-10, 4-3](#)
- DefaultSessionService [3-11, 4-3](#)
- Destination-IP-Address [B-4](#)
- Destination-port [B-4](#)
- DetectOutOfOrderAccountingPacket [3-62, 4-63](#)
- DetectOutOfOrderAccountingPackets [4-63](#)
- Dictionaries
  - Types of [11-1](#)
- Dictionary

- attribute [4-65](#)

- Disable-Accounting-On-Off-Broadcast [B-6](#)
- DNSLookupAndLDAPRebindInterval [4-51, 20-6](#)
- DropPacket. [3-22, 4-12, 4-14, 4-16, 4-17, 4-18, 4-19, 4-24](#)
- Dynamic-DNS-HostName [B-7](#)
- Dynamic-Search-Filter [B-7](#)
- Dynamic-Service-Loop-Limit [B-7](#)
- Dynamic-User-Password-Attribute [B-7](#)

## E

- EAP [4-13, 9-1](#)
  - authentication mechanism [9-1](#)
  - fatal error packet handling [4-72](#)
  - SilentDiscard [4-72](#)
- EAP-Actual-Identity [B-7](#)
- EAP authentication [9-1](#)
- EAP-Authentication-Mode [B-8](#)
- EapBadMessagePolicy [4-72](#)
- EAP-FAST
  - keystores [4-66](#)
- EAP-GTC [9-16, 9-17](#)
- EAP-LEAP [9-18](#)
- EAP-MD5 [9-19](#)
- EAP-MSChapv2 [9-21](#)
- EAP-Negotiate [9-20, 9-21](#)
- EAP response messages [4-72](#)
- EAP-SIM [9-23](#)
- EAP-SIM authentication [9-25, 9-26](#)
- eap-trace command [9-41](#)
- EAP-Transport Level Security [9-27](#)
- Easysoft Open Source [21-12](#)
- Empty string [2-1](#)
- EnableNotifications [3-93, 4-8](#)
- EntryPoint [4-24](#)
- ENUM
  - attribute type [4-76](#)
- Environment Dictionary [1-4, 1-7, 11-1, 11-3](#)
- Environment Dictionary script [11-4](#)

## Environment variable

Accounting-Service [B-2](#)  
 Acquire-Group-Session-Limit [B-2](#)  
 Acquire-IP-Dynamic [B-2](#)  
 Acquire-IP-Per-NAS-Port [B-2](#)  
 Acquire-IPX-Dynamic [B-2](#)  
 Acquire-Subnet-Dynamic [B-3](#)  
 Acquire-User-Session-Limit [B-3](#)  
 Acquire-USR-VPN [B-3](#)  
 Allow-Null-Password [B-3](#)  
 Authentication-Service [B-3](#)  
 Authorization-Service [B-3](#)  
 Current-Group-Count [B-4](#)  
 Dynamic-Search-Path [B-7](#)  
 Group-Session-Limit [B-8](#)  
 Ignore-Accounting-Signature [B-8](#)  
 Incoming-Translation-Groups [B-9](#)  
 Misc-Log-Msg-Info [B-9](#)  
 Reject-Reason [B-10](#)  
 Remote-Server [B-10](#)  
 Remote-Servers-Tried [B-10](#)  
 Request-Authenticator [B-11](#)  
 Request-Type [B-11](#)  
 Require-User-To-Be-In-Authorization-List [B-12](#)  
 Response-Type [B-12](#)  
 Session-Key [B-12](#)  
 Session-Manager [B-12](#)  
 Session-Service [B-13](#)  
 Source-IP-Address [B-13](#)  
 Trace-Level [B-15](#)  
 Unavailable-Resource [B-15](#)  
 Unavailable-Resource-Type [B-15](#)  
 User Authorization-Script [B-15](#)  
 User-Group [B-16](#)  
 User-Group-Session-Limit [B-16](#)  
 User-Name [B-16](#)  
 User-Profile [B-16](#)  
 User-Session-Limit [B-16](#)

## Error codes

aregcmd [2-19](#)  
 EscapeSpecialCharInUserName [4-51](#)  
 ExecCLIDRule [18-16](#)  
 ExecDNISRule [18-16](#)  
 ExecNASIPRule [18-17](#)  
 ExecRealmRule [18-15](#)  
 ExecTimeRule [18-12, 18-20](#)  
 Extensible Authentication Protocols [8-1, 9-1, 22-1](#)  
 Extension points [11-2](#)

---

**F**

Failover policy [3-35, 4-17, 4-19, 4-20](#)  
 Fatal error packet [4-72](#)  
 Filename [4-24](#)  
 FilenamePrefix [4-14](#)  
 file service [3-18, 3-20, 4-11, 4-14](#)  
     FilenamePrefix [4-14](#)  
     MaxFileAge [4-14](#)  
     MaxFileSize [4-14](#)  
 Filter [4-50](#)  
 firstKey method [A-2](#)  
 Force update [17-12](#)  
 Framed-IP-Address [1-15](#)  
 Framed Protocol [1-15](#)  
 FramedRouting [4-42](#)

---

**G**

Gateway  
     Description [4-39](#)  
     IPAddress [4-39](#)  
     LocationID [4-39](#)  
     Name [4-39](#)  
     SharedSecret [4-39](#)  
     TunnelRefresh [4-39](#)  
 Gateways [4-42](#)  
 get method [A-2](#)

Grouping property [18-2](#)  
 Group service [16-5, 16-12, 16-14](#)  
 Group-Session-Limit Resource Manager [1-4, 3-82, 4-37](#)  
 GUI  
   launching [3-1](#)  
   logging in [3-3](#)  
   log out [3-4](#)

---

## H

HiddenAttributes [4-4](#)  
 Home-Agent-Ipv6 [4-39](#)  
 Home-Agent-IPv6 resource manager [3-82](#)  
 Home-Agent resource manager [3-82](#)  
 HostName [4-50](#)  
 Hot configuration [12-6](#)  
 Hot-lining [17-39](#)

---

## I

Identifier [4-42](#)  
 IncomingScript [1-6, 3-10, 3-49, 3-91, 4-2, 4-7, 4-10, 4-30, 4-57](#)  
 IncomingScriptFailed reply message [4-74](#)  
 IncomingScript RejectedRequest reply message [4-74](#)  
 Incoming scripts [1-3, 1-13](#)  
 Information collection  
   automatic [17-32, 17-33](#)  
 InitEntryPoint [3-18, 4-11, 4-24](#)  
 InitEntryPointArgs [4-24](#)  
 InitialBackgroundTimerSleepTime [4-61](#)  
 InitializeArg [4-11](#)  
 InitialTimeout [4-58](#)  
 Input queue  
   high threshold [23-4](#)  
 Interfaces properties [4-1](#)  
 InternalError reply message [4-74](#)  
 IPADDR  
   attribute type [4-75](#)

IPAddress [3-92, 4-6](#)  
 IP-Dynamic Resource Manager [1-4, 3-82, 4-37](#)  
 IP-Per-NAS-Port Resource Manager [1-4, 3-82, 4-37](#)  
 IPX-Dynamic Resource Manager [1-4, 3-82, 4-37](#)  
 isEmpty method [A-2](#)

---

## J

Java service [4-16](#)  
 JavaVMOptions [4-63](#)

---

## K

KeyStores [4-66](#)

---

## L

LDAP [20-1](#)  
   hostname [20-3](#)  
   MultipleServersPolicy [20-2](#)  
   protocol [4-49](#)  
   RemoteServers [4-45](#)  
 ldap  
   BindName [4-50](#)  
   BindPassword [4-50](#)  
   Filter [4-50](#)  
   HostName [4-50](#)  
   LDAPToEnvironmentMappings [4-52](#)  
   LDAPToRadiusMappings [4-52](#)  
   LimitOutstandingRequests [4-50](#)  
   MaxOutstandingRequests [4-50](#)  
   MaxReferrals [4-51](#)  
   PasswordEncryptionStyle [4-51](#)  
   ReferralAttribute [4-51](#)  
   ReferralFilter [4-51](#)  
   SearchPath [4-50](#)  
   Timeout [4-50, 4-54](#)  
   UserPasswordAttribute [4-50](#)

- UseSSL [4-52](#)
- LDAP Accounting [3-99](#)
- LDAP Rebind [20-6](#)
  - failures [20-6](#)
- LDAP RemoteServer [20-3](#)
- LDAP server [1-15](#)
- LDAP service [20-2](#)
- LDAPToCheckItemMappings [4-52, 20-7](#)
- LDAPToEnvironmentMappings [4-52, 20-7](#)
- LDAPToRadiusMappings [4-52, 20-7](#)
- LEAP [9-18](#)
- Lightweight Directory Access Protocol [20-1](#)
- LimitOutstandingRequests [4-50](#)
- local [3-21, 4-17, B-16](#)
  - UserList type [3-23, 4-3, 4-18](#)
- localhost [5-7](#)
- Local Service [6-2](#)
- local service [3-23, 4-3, 4-18](#)
- LogFileCount [4-62](#)
- Log files [28-3](#)
  - file system [7-3](#)
  - managing [7-3](#)
- LogFileSize [4-62](#)
- Logging in [2-7](#)
  - GUI [3-3](#)
- Logging out [2-7](#)
- login command [2-7](#)
- Login page [3-3](#)
- log method [A-2](#)
- LogServerActivity [4-59](#)

---

## M

- Malformed Request reply message [4-74](#)
- MapSourceIPAddress [11-11](#)
- Master-URL-Fragment [17-11, B-9](#)
- MaxFileAge [4-14](#)
- MaxFileSize [4-14](#)
- MaximumIncomingRequestRate [4-67](#)

- MaximumNumberOfRadiusPackets [4-59](#)
- MaximumODBCResultSize [4-63](#)
- MaximumOutstandingRequests [4-68](#)
- MaxOutstandingRequests [4-50](#)
- MaxReferrals [4-51](#)
- MaxTries [4-57](#)
- MCD [25-1](#)
  - mcddcd.d01-d03 [25-2](#)
  - mcddcd.txt [25-2](#)
  - MCD database [6-4](#)
  - mcddb.dbd [25-2](#)
  - mcddb.k01-k03 [25-2](#)
  - mcddshadow [25-1](#)
- Measurements
  - prepaid billing [16-7](#)
- Message logging (Linux) [27-4](#)
- Message logging (Solaris) [27-3](#)
- Microsoft WPS [17-9](#)
- MinimumSocketBufferSize [4-61](#)
- Mobile Node-Home Agent [19-1](#)
- MPLS [13-1](#)
- multiple [1-1](#)
- MultipleServersPolicy [4-17, 4-19, 4-20, 20-2, 21-7](#)
- MVA
  - radclient [5-6](#)

---

## N

- NAS [1-1, 7-1](#)
- NAS IP Address [4-75](#)
- NAS-IP-Address [1-15](#)
- NAS-Port [1-15](#)
- NAS-Vendor-Behind-the-Proxy [11-2](#)
- Neighbor [4-42](#)
- NetMask [3-92, 4-8](#)
- nextKey method [A-3](#)
- NotificationProperties [3-94, 4-8](#)
- NumberOfRemoteUDPSServerSockets [4-67](#)

---

**O**

## ODAP

- accounting service [13-8](#)
  - address ranges [13-2](#)
  - AllowAnonymousPassword property [13-6](#)
  - CiscoIncomingScript [13-3](#)
  - configuration summary [13-5](#)
  - configuring [13-5](#)
  - configuring clients [13-15](#)
  - configuring Session Managers [13-14](#)
  - detailed configuration [13-5](#)
  - on-demand address pool [13-1](#)
  - Resource Managers [13-9](#)
  - service [13-7](#)
  - Session Managers [13-8](#)
  - userlist [13-5](#)
  - users [13-6](#)
  - vendor type [13-4](#)
- ODBC.ini file [21-2](#)
- ODBCDataSource [21-9, 21-11, 21-12](#)
- ODBC RemoteServer [21-7](#)
- ODBC service [21-6](#)
- ODBCToEnvironmentMappings [21-11](#)
- ODBCToRadiusMappings [21-11](#)
- ORACLE\_HOME [21-2](#)
- Oracle Driver
- Easysoft Open Source [21-12](#)
- Oracle functions [21-10](#)
- order dependent commands
- see also aregcmd
- OS paging size [3-79, 4-31](#)
- OutagePolicy [3-22, 4-12, 4-14, 4-16, 4-17, 4-18, 4-19, 4-24](#)
- OutageScript [3-22, 4-12, 4-14, 4-16, 4-17, 4-18, 4-19, 4-24](#)
- OutgoingScript [3-10, 3-49, 3-91, 4-2, 4-7, 4-10, 4-31, 4-57](#)
- OutgoingScriptFailed [4-74](#)
- OutgoingScriptRejectedRequest [4-74](#)
- Outgoing scripts [1-3, 1-8, 1-13](#)
- Outgoing-Translation-Groups [B-9](#)

Overview [1-1](#)

---

**P**

- Packet buffering [7-10](#)
- Packet fields [1-14](#)
- packet-identifier [5-4](#)
- Packet of disconnect [17-36](#)
- Paging size
- operating system [4-41](#)
- Paging size (operating system) [3-79, 4-31](#)
- ParseTranslationGroupsByCLID [18-10, 18-21](#)
- ParseTranslationGroupsByDNIS [18-10, 18-20, 18-21](#)
- ParseTranslationGroupsByReal [18-20](#)
- ParseTranslationGroupsByRealm [18-10](#)
- Password
- length of [3-16, 4-4](#)
- Password change [17-12](#)
- PasswordEncryptionStyle [4-51](#)
- PCO-Parse-Client-Outgoing [16-15](#)
- PEAP Version 0 [9-42](#)
- PEAP Version 1 [9-47](#)
- Performance
- aregcmd [2-3](#)
- PhantomSessionTimeout [3-81, 4-33](#)
- Policies
- configuring [18-1](#)
  - validation [18-3](#)
- Policy [18-1](#)
- Policy engine
- attribute translation [18-9](#)
  - parsing translation groups [18-10](#)
  - reducing overhead [18-13](#)
  - time of day access restrictions [18-11](#)
  - wildcard support [18-2](#)
- Port
- LDAP [4-50](#)
- Port 8080 [3-1](#)
- Ports [4-65](#)

Ports properties [4-1](#)

PPO-Parse-Prepaid-Outgoing [16-16](#)

PPP [1-3, 1-15, 3-11, 4-43](#)

Prepaid

AA service [16-5, 16-12](#)

group service [16-5, 16-12, 16-14](#)

Prepaid billing

measurements [16-7](#)

Protected EAP [9-1](#)

Proxy server [1-15](#)

put method [A-3](#)

## Q

Query-Notify [17-6](#)

Query-Notify AttributeGroup

configuration example [17-9](#)

Query-Notify client

configuration example [17-9](#)

Query-Service [B-9](#)

query-sessions command [4-34](#)

## R

radclient

callsPerSecond [5-11](#)

multivalued attributes [5-6](#)

syntax [5-1](#)

testing EAP-TTLS [9-38](#)

timetest [5-10](#)

radclient commands [9-40](#)

RADIUS

attribute name [5-5](#)

attributes [C-1](#)

messages [1-14](#)

packet type identifier [5-4](#)

program flow [1-13](#)

protocol [1-12](#)

server [2-3, 2-7, 4-6, 5-3, 11-4](#)

server test tool [5-1](#)

RADIUS\_WORKER\_THREAD\_COUNT [17-4](#)

RADIUS EXtension. See REX

RADIUS packet fields [1-14](#)

RadiusServer object [1-2, 4-1](#)

Re-Accounting-Service [B-9](#)

ReactivateTimerInterval [4-46](#)

Realm [B-10](#)

Re-Authentication-Service [B-10](#)

Re-Authorization-Service [B-10](#)

ReferralAttribute [4-51](#)

ReferralFilter [4-51](#)

RejectAll [3-22, 4-12, 4-14, 4-16, 4-17, 4-18, 4-19, 4-24](#)

Reject-Reason [B-10](#)

release-sessions command [4-34](#)

Remote-Group-Session-Limit resource manager [3-83](#)

Remote-IP-Dynamic resource manager [3-82](#)

RemoteLDAPServiceThreadTimerInterval [4-61](#)

RemoteRadiusServerInterface [4-64](#)

RemoteServer

ODBC-Accounting [4-55](#)

prepaid-crb [4-57](#)

RemoteServers [20-2, 21-7](#)

Remote servers

policy [4-17, 4-19, 4-20](#)

RemoteServer types [4-46](#)

Remote-User-Session-Limit resource manager [3-83](#)

REMOVE\_ALL [A-3, A-10](#)

remove method [A-3](#)

Renewal [17-12](#)

RepIPMaster [12-9](#)

REPLACE [A-2, A-3, A-5, A-8, A-9, A-10](#)

Replication

archive [12-4](#)

automatic resynchronization [12-5](#)

configuration settings [12-6](#)

data flow [12-3](#)

data integrity [12-4](#)

- hot configuration [12-6](#)
- hot-standby [12-1](#)
- impact on request processing [12-6](#)
- RepIPAddress [12-8](#)
- RepTransactionArchiveLimit [12-2, 12-8](#)
- RepTransactionSyncInterval [12-2, 12-7, 12-10, 12-11](#)
- security [12-4](#)
- slaves [12-9](#)
- slave server [12-3](#)
- transaction order [12-5](#)
- transaction verification [12-4](#)
- Reply Messages [4-73](#)
- RepMasterIPAddress [12-9](#)
- RepMasterPort [12-9](#)
- RepPort [12-8](#)
- RepSecret [12-8](#)
- RepType [12-7](#)
- Request Dictionary [1-13, 11-1](#)
  - script [11-3](#)
- Request-Type Packets
  - Access-Accept [B-11](#)
  - Access-Challenge [B-11](#)
  - Access-Reject [B-11](#)
  - Access-Request [B-11](#)
  - Accounting-Request [B-11](#)
  - Accounting-Response [B-11](#)
  - Ascend-IPA-Allocate [B-11](#)
  - Ascend-IPA-Release [B-11](#)
  - Status-Client [B-11](#)
  - Status-Server [B-11](#)
  - USR-Enhanced-Radius [B-11](#)
  - USR-NAS-Reboot-Request [B-11](#)
  - USR-NAS-Reboot-Response [B-11](#)
  - USR-Resource-Free-Request [B-11](#)
  - USR-Resource-Free-Response [B-11](#)
  - USR-Resource-Query-Request [B-11](#)
  - USR-Resource-Query-Response [B-11](#)
- RequireNASsBehindProxyBeInClientList [4-59, 4-71](#)
- Resource allocation
  - dynamic [1-4](#)
- Resource Managers [1-4, 4-37, 4-38](#)
  - Group-Session-Limit [4-39](#)
  - Home-Agent [4-39](#)
  - IP-Dynamic [4-39](#)
  - IP-Per-NAS-Port [4-40](#)
  - IPX-Dynamic [4-40](#)
  - subnet-dynamic [4-41](#)
  - User-Session-Limit [4-42](#)
  - USR-VPN [4-42](#)
- Response Dictionary [1-13, 11-1](#)
  - script [11-4](#)
- Response-Type [B-12](#)
- Resynchronization
  - automatic [12-5](#)
  - full [12-5](#)
- REX
  - scripts [3-17, 4-10](#)
- REX attribute dictionary
  - getBytes method [A-7](#)
  - putBytes method [A-9](#)
- REX environment dictionary
  - allocateMemory [A-11](#)
  - clear [A-11](#)
  - containsKey [A-11](#)
  - firstKey [A-11](#)
  - get [A-12](#)
  - isEmpty [A-12](#)
  - log [A-12](#)
  - nextKey [A-12](#)
  - put [A-12](#)
  - remove [A-12](#)
  - reschedule [A-12](#)
  - size [A-13](#)
  - trace [A-13](#)
- rex service
  - EntryPoint [4-24](#)
  - Filename [4-24](#)
  - InitEntryPoint [4-24](#)

- InitEntryPointArgs [4-24](#)
  - RFC
    - 2866 [7-1](#)
    - RFC 2138 [4-75, C-1](#)
    - RFC Compliance [4-66](#)
    - RolloverSchedule [7-3](#)
      - time format [7-4](#)
    - RoundRobin policy [3-35, 4-17, 4-19, 4-20](#)
    - Routing requests [18-4](#)
      - based on CLID [18-6](#)
      - based on DNIS [18-5](#)
      - based on NASIP [18-7](#)
      - based on realm [18-4](#)
      - based on User-Name Prefix [18-8](#)
    - RPC services [2-4](#)
    - Rules
      - script and attribute requirements [18-3](#)
      - standard scripts [18-15](#)
- 
- S**
- Scripting point [11-1](#)
    - NAS IncomingScript [11-4](#)
  - Scripts [11-6](#)
    - ACMEOutgoingScript [11-7](#)
    - adding script definition [11-4](#)
    - AltigaIncomingScript [11-8](#)
    - ANAAAOutgoing [11-8](#)
    - AuthorizePPP [11-8](#)
    - AuthorizeService [11-8](#)
    - AuthorizeSLIP [11-9](#)
    - AuthorizeTelnet [11-9](#)
    - choosing the type of script [11-3](#)
    - determining goal [11-1](#)
    - ExecCLIDRule [11-10](#)
    - ExecDNISRule [11-10](#)
    - ExecFilterRule [11-10](#)
    - ExecRealmRule [11-10](#)
    - extension points [11-2](#)
    - ParseAAAREalm [11-11](#)
    - ParseAARealm [11-11](#)
    - ParseAASRealm [11-12](#)
    - ParseProxyHints [11-12](#)
    - ParseServiceAndAAAREalmHints [11-12](#)
    - ParseServiceAndAAASRealmHints [11-12](#)
    - ParseServiceAndAARealmHints [11-12](#)
    - ParseServiceAndAASRealmHints [11-12](#)
    - ParseServiceAndProxyHints [11-13](#)
    - ParseServiceHints [11-13](#)
    - ParseTranslationGroupsByCLID [11-13](#)
    - ParseTranslationGroupsByDNIS [11-13](#)
    - ParseTranslationGroupsByRealm [11-13](#)
    - tParseAASRealm [11-12](#)
    - tParseProxyHints [11-12](#)
    - tParseServiceAndAAAREalmHints [11-12](#)
    - tParseServiceAndProxyHints [11-13](#)
    - tParseServiceHints [11-13](#)
    - types of [1-3](#)
    - UseCLIDAsSessionKey [11-13](#)
    - USROutgoingScript [11-14](#)
      - writing [11-2](#)
  - SearchPath [4-50](#)
  - SearchScope [4-51](#)
  - SelectPolicy [18-1](#)
  - Send-PEAP-URI-TLV [17-11](#)
  - Server
    - master [12-1](#)
    - primary [12-1](#)
    - secondary [12-1](#)
  - Server health [28-8](#)
  - Services
    - file [3-20, 4-14](#)
    - ldap [4-19](#)
    - local [3-21, 3-23, 4-3, 4-17, 4-18, B-16](#)
    - proxy requests [4-45](#)
    - radius [4-19](#)
    - tacacs-udp [4-19](#)
    - used for [1-3](#)



services [3-20, 4-11](#)  
 Services objects [3-20, 4-11](#)  
 ServiceUnavailable reply message [4-74](#)  
 SESM [15-1](#)  
 SessionBackingStoreSynchronizationInterval [4-60](#)  
 session-cache [4-41](#)  
 Session magic number [3-62, 4-63](#)  
 Session Management
 

- definition [1-1](#)
- types of [1-4](#)

 Session Managers [4-31](#)  
 Session record size [3-79, 4-31, 4-41](#)  
 Setting attributes
 

- spaces in value [2-12, 6-9](#)

 Shadow backups [25-1](#)  
 Shared key
 

- MN-HA [19-1](#)

 Shared libraries [A-1](#)  
 SharedSecret [4-39, 4-57](#)  
 Shared secret [3-92, 4-7](#)

- definition [1-12](#)

 Sign up [17-11](#)  
 Sign-up URL [17-10](#)  
 size method [A-3](#)  
 SLIP [1-15](#)  
 SNMP [4-65, 23-1](#)

- configuration files [23-7, 23-8](#)
- Trap recipients [23-9](#)
- traps [23-3](#)

 SNMP Configuration
 

- community string [23-9](#)
- snmp.conf file [23-8](#)
- snmpd.conf file [23-8](#)

 SQLDefinition [21-9](#)  
 SQL queries [21-10](#)  
 SQLStatement [21-9](#)  
 SQL syntax restrictions [21-10](#)  
 SSG [15-1](#)  
 stats command [B-9](#)

sticky commands [2-8](#)  
 STRING
 

- attribute type [4-75](#)

 SynthesizeReverseZone [4-66](#)  
 syslog messages [27-1](#)

---

## T

tacacs-udp [4-45](#)  
 Tcl attribute dictionary [A-1, A-2](#)

- addProfile method [A-2](#)
- clear method [A-2](#)
- firstKey method [A-2](#)
- get method [A-2](#)
- isEmpty method [A-2](#)
- log method [A-2](#)
- nextKey method [A-3](#)
- remove method [A-3](#)
- size method [A-3](#)
- trace method [A-3](#)

 Tcl scripts [11-6](#)  
 TerminationAction reply message [4-74](#)  
 Timeout [4-50, 4-54](#)  
 timetest [5-10](#)  
 tMapSourceIPAddress [11-11](#)  
 tParseAAResult [11-11](#)  
 tParseServiceAndAAASRealmHints [11-12](#)  
 tParseServiceAndAAResultHints [11-12](#)  
 tParseServiceAndAASRealmHints [11-12](#)  
 TraceFileCount [4-62](#)  
 trace-file-count [2-16](#)  
 TraceFileSize [4-62](#)  
 trace method [A-3](#)  
 Trap configuration
 

- directories searched [23-7](#)

 Trap recipients [23-9](#)  
 Traps
 

- carAccountingLoggingFailure [23-6](#)
- carInputQueueFull [23-4](#)

carInputQueueNotVeryFull [23-5](#)  
 carOtherAccServerResponding [23-6](#)  
 carOtherAuthServeNotrResponding [23-5](#)  
 carOtherAuthServerResponding [23-5](#)  
 carServerStart [23-4](#)  
 carServerStop [23-4](#)  
 configuring [23-7](#)  
 supported [23-3](#)

Trusted ID

- configuration overview [15-2](#)

Trusted Identity [15-1](#)

tunnel command [9-41](#)

TunnelRefresh [4-39](#)

---

## U

UDPPacketSize [4-59](#)  
 UINT32
 

- attribute type [4-75](#)

UnableToAcquireResource reply message [4-74](#)

UNDEFINED
 

- attribute type [4-75](#)

UNIX directories [1-2](#)

UnknownUser reply message [4-73](#)

use\_challenge parameter [5-3](#)

UseAdvancedDuplicateDetection [4-62, 4-72](#)

UseBinaryPasswordComparison [4-52](#)

UserDefined [4-4](#)

User extensions. See Scripts.

UserGroups
 

- check item attributes [17-35](#)

UserList [1-2](#)

- check item attributes [17-34](#)

UserNotEnabled reply message [4-74](#)

User objects [1-2](#)

UserPasswordAttribute [4-50](#)

UserPasswordInvalid [4-74](#)

User-Profile [B-16](#)

User profiles [1-3](#)

User properties [4-4](#)  
 UserService [9-19](#)  
 User-Session-Limit [B-16](#)  
 User-Session-Limit Resource Manager [3-82, 4-37](#)  
 User-session-limit Resource Manager [1-4](#)  
 UseSSL [4-52](#)  
 Using SESM with CAR [15-1](#)  
 USRIncomingScript [11-13](#)  
 USRIncomingscript-ignoreAccountingSignature [11-14](#)  
 USR-VPN
 

- FramedRouting [4-42](#)
- Gateways [4-42](#)
- Identifier [4-42](#)
- Neighbor [4-42](#)

USR-VPN Resource Manager [1-4, 3-82, 4-37](#)

---

## V

valueAsInt [5-7](#)  
 valueAsIPAddress [5-7](#)  
 Variables
 

- environment [B-1](#)
- radclient [5-10](#)

VENDOR\_ SPECIFIC
 

- attribute type [4-76](#)

VendorID [4-76](#)

Vendor specific attributes
 

- XML [C-87](#)

Vendor-specific attributes [C-13](#)

- 3GPP2 [C-13, C-15](#)
- ACC [C-22](#)
- Altiga [C-27](#)
- Ascend [C-30](#)
- Bay Networks [C-45](#)
- Cabletron [C-46](#)
- Cisco [C-48](#)
- Compatible [C-51](#)
- Nomadix [C-53](#)
- RedCreek [C-53, C-56](#)

Telebit [C-59](#)  
WiMax [C-86](#)  
WISPr [C-86](#)  
VHG/PE router [13-1](#)  
VPN [1-9](#)  
VRF [1-9](#)  
VRFs [13-2](#)  
VSAs [C-13](#)

---

## W

WAP [17-6, 1-9](#)  
Windows 95 Registry [1-2](#)  
Windows Provisioning Service (WPS) [17-9](#)  
Wireless Application Protocol [17-6](#)  
WPS [1-9](#)

---

## X

XML Query Identity [14-2](#)

