



Cisco ONS 15454 DWDM Procedure Guide

Product and Software Release 7.0
Last Updated: June 2012

Corporate Headquarters

Cisco Systems, Inc.
170 West Tasman Drive
San Jose, CA 95134-1706
USA
<http://www.cisco.com>
Tel: 408 526-4000
800 553-NETS (6387)
Fax: 408 526-4100

Text Part Number: 78-17206-02



THE SPECIFICATIONS AND INFORMATION REGARDING THE PRODUCTS IN THIS MANUAL ARE SUBJECT TO CHANGE WITHOUT NOTICE. ALL STATEMENTS, INFORMATION, AND RECOMMENDATIONS IN THIS MANUAL ARE BELIEVED TO BE ACCURATE BUT ARE PRESENTED WITHOUT WARRANTY OF ANY KIND, EXPRESS OR IMPLIED. USERS MUST TAKE FULL RESPONSIBILITY FOR THEIR APPLICATION OF ANY PRODUCTS.

THE SOFTWARE LICENSE AND LIMITED WARRANTY FOR THE ACCOMPANYING PRODUCT ARE SET FORTH IN THE INFORMATION PACKET THAT SHIPPED WITH THE PRODUCT AND ARE INCORPORATED HEREIN BY THIS REFERENCE. IF YOU ARE UNABLE TO LOCATE THE SOFTWARE LICENSE OR LIMITED WARRANTY, CONTACT YOUR CISCO REPRESENTATIVE FOR A COPY.

The following information is for FCC compliance of Class A devices: This equipment has been tested and found to comply with the limits for a Class A digital device, pursuant to part 15 of the FCC rules. These limits are designed to provide reasonable protection against harmful interference when the equipment is operated in a commercial environment. This equipment generates, uses, and can radiate radio-frequency energy and, if not installed and used in accordance with the instruction manual, may cause harmful interference to radio communications. Operation of this equipment in a residential area is likely to cause harmful interference, in which case users will be required to correct the interference at their own expense.

The following information is for FCC compliance of Class B devices: The equipment described in this manual generates and may radiate radio-frequency energy. If it is not installed in accordance with Cisco's installation instructions, it may cause interference with radio and television reception. This equipment has been tested and found to comply with the limits for a Class B digital device in accordance with the specifications in part 15 of the FCC rules. These specifications are designed to provide reasonable protection against such interference in a residential installation. However, there is no guarantee that interference will not occur in a particular installation.

Modifying the equipment without Cisco's written authorization may result in the equipment no longer complying with FCC requirements for Class A or Class B digital devices. In that event, your right to use the equipment may be limited by FCC regulations, and you may be required to correct any interference to radio or television communications at your own expense.

You can determine whether your equipment is causing interference by turning it off. If the interference stops, it was probably caused by the Cisco equipment or one of its peripheral devices. If the equipment causes interference to radio or television reception, try to correct the interference by using one or more of the following measures:

- Turn the television or radio antenna until the interference stops.
- Move the equipment to one side or the other of the television or radio.
- Move the equipment farther away from the television or radio.
- Plug the equipment into an outlet that is on a different circuit from the television or radio. (That is, make certain the equipment and the television or radio are on circuits controlled by different circuit breakers or fuses.)

Modifications to this product not authorized by Cisco Systems, Inc. could void the FCC approval and negate your authority to operate the product.

The Cisco implementation of TCP header compression is an adaptation of a program developed by the University of California, Berkeley (UCB) as part of UCB's public domain version of the UNIX operating system. All rights reserved. Copyright © 1981, Regents of the University of California.

NOTWITHSTANDING ANY OTHER WARRANTY HEREIN, ALL DOCUMENT FILES AND SOFTWARE OF THESE SUPPLIERS ARE PROVIDED "AS IS" WITH ALL FAULTS. CISCO AND THE ABOVE-NAMED SUPPLIERS DISCLAIM ALL WARRANTIES, EXPRESSED OR IMPLIED, INCLUDING, WITHOUT LIMITATION, THOSE OF MERCHANTABILITY, FITNESS FOR A PARTICULAR PURPOSE AND NONINFRINGEMENT OR ARISING FROM A COURSE OF DEALING, USAGE, OR TRADE PRACTICE.

IN NO EVENT SHALL CISCO OR ITS SUPPLIERS BE LIABLE FOR ANY INDIRECT, SPECIAL, CONSEQUENTIAL, OR INCIDENTAL DAMAGES, INCLUDING, WITHOUT LIMITATION, LOST PROFITS OR LOSS OR DAMAGE TO DATA ARISING OUT OF THE USE OR INABILITY TO USE THIS MANUAL, EVEN IF CISCO OR ITS SUPPLIERS HAVE BEEN ADVISED OF THE POSSIBILITY OF SUCH DAMAGES.

Cisco and the Cisco logo are trademarks or registered trademarks of Cisco and/or its affiliates in the U.S. and other countries. To view a list of Cisco trademarks, go to this URL: www.cisco.com/go/trademarks. Third-party trademarks mentioned are the property of their respective owners. The use of the word partner does not imply a partnership relationship between Cisco and any other company. (1110R)

Any Internet Protocol (IP) addresses used in this document are not intended to be actual addresses. Any examples, command display output, and figures included in the document are shown for illustrative purposes only. Any use of actual IP addresses in illustrative content is unintentional and coincidental.

Cisco ONS 15454 DWDM Procedure Guide, Release 7.0
Copyright © 2012 Cisco Systems, Inc. All rights reserved.



About this Guide xlv

- Revision History xlv
- Document Objectives xlvii
- Audience xlvii
- Document Organization xlvii
- Related Documentation xlviii
- Document Conventions xlviii
- Obtaining Optical Networking Information lv
 - Where to Find Safety and Warning Information lv
 - Cisco Optical Networking Product Documentation CD-ROM lv
- Obtaining Documentation and Submitting a Service Request lv

CHAPTER 1

Install the Shelf and Common Control Cards 1-1

- Before You Begin 1-1
- Required Tools and Equipment (ANSI) 1-3
 - Cisco-Supplied Materials (ANSI) 1-3
 - User-Supplied Materials (ANSI) 1-3
 - Tools Needed (ANSI) 1-4
 - Test Equipment (ANSI) 1-4
- Required Tools and Equipment (ETSI) 1-5
 - Cisco-Supplied Equipment (ETSI) 1-5
 - User-Supplied Equipment (ETSI) 1-5
 - Tools Needed (ETSI) 1-6
 - Test Equipment (ETSI) 1-6
- NTP- G1 Unpack and Inspect the Shelf Assembly 1-6
 - DLP- G1 Unpack and Verify the Shelf Assembly 1-7
 - DLP- G2 Inspect the Shelf Assembly 1-7
- NTP- G2 Install the Shelf Assembly 1-8
 - DLP- G3 Reverse the Mounting Bracket to Fit a 19-inch (482.6-mm) Rack (ANSI Only) 1-10
 - DLP- G4 Install the External Brackets and Air Filter (ANSI Only) 1-11
 - DLP- G5 Mount the Shelf Assembly in a Rack (One Person) 1-13
 - DLP- G6 Mount the Shelf Assembly in a Rack (Two People) 1-15
 - DLP- G7 Mount Multiple Shelf Assemblies in a Rack 1-16
 - DLP- G8 Install the Air Ramp 1-19

- NTP- G3 Open and Remove the Front Door **1-20**
 - DLP- G9 Open the Front Cabinet Compartment (Door) **1-20**
 - DLP- G10 Remove the Front Door **1-21**
- NTP- G4 Open and Remove the FMEC Cover (ETSI Only) **1-23**
 - DLP- G11 Open the FMEC Cover **1-24**
 - DLP- G12 Remove the FMEC Cover **1-25**
- NTP- G5 Remove the Backplane Covers (ANSI Only) **1-26**
 - DLP- G13 Remove the Lower Backplane Cover **1-27**
 - DLP- G14 Remove the Backplane Sheet Metal Cover **1-27**
- NTP- G6 Install the MIC-A/P and MIC-T/C/P FMECs (ETSI Only) **1-28**
- NTP- G7 Install the Power and Ground **1-30**
 - DLP- G15 Connect the Office Ground to the ONS 15454 ETSI **1-32**
 - DLP- G16 Connect the Office Ground to the ONS 15454 ANSI **1-33**
 - DLP- G17 Connect Office Power to the ONS 15454 ETSI **1-35**
 - DLP- G18 Connect Office Power to the ONS 15454 ANSI **1-36**
 - DLP- G19 Turn On and Verify Office Power **1-39**
- NTP- G8 Install the Fan-Tray Assembly **1-40**
- NTP- G9 Install the Alarm Expansion Panel (ANSI Only) **1-43**
- NTP- G10 Attach Wires to Alarm, Timing, LAN, and Craft Pin Connections **1-46**
 - DLP- G20 Install Alarm Wires on the MIC-A/P (ETSI Only) **1-47**
 - DLP- G21 Install Timing Wires on the MIC-C/T/P (ETSI Only) **1-50**
 - DLP- G22 Install LAN Wires on the MIC-C/T/P (ETSI Only) **1-51**
 - DLP- G23 Install Alarm Wires on the Backplane (ANSI Only) **1-52**
 - DLP- G24 Install Timing Wires on the Backplane (ANSI Only) **1-54**
 - DLP- G25 Install LAN Wires on the Backplane (ANSI Only) **1-55**
 - DLP- G26 Install the TL1 Craft Interface Wires (ANSI Only) **1-56**
- NTP- G11 Install an External Wire-Wrap Panel on the AEP (ANSI Only) **1-57**
- NTP- G12 Install and Close the FMEC Cover (ETSI Only) **1-61**
- NTP- G13 Install the Rear Cover (ANSI Only) **1-62**
- NTP- G14 Install DWDM Equipment **1-64**
 - DLP- G27 Install the DCU Shelf Assembly **1-65**
 - DLP- G28 Install the Fiber Patch-Panel Tray **1-66**
 - DLP- G29 Install the Fiber-Storage Tray **1-66**
 - DLP- G371 Install the Ethernet Adapter Panel **1-67**
 - DLP- G351 Install the Y-Cable Module Tray **1-67**
 - DLP- G30 Install the FlexLayer Shelf **1-68**
 - DLP- G31 Install the FlexLayer Modules **1-69**
 - DLP- G32 Install the Y-Cable Protection Modules in the FlexLayer Shelf **1-70**

DLP- G377 Install the Y-Cable Protection Modules in the Y-Cable Module Tray	1-71
NTP- G15 Install the Common Control Cards	1-72
DLP- G33 Install the TCC2 or TCC2P Card	1-73
DLP- G34 Install the AIC-I Card	1-76
DLP- G309 Install the MS-ISC-100T Card	1-77
NTP- G145 Connect a Multishelf Node and Subtending Shelves to an MS-ISC-100T Card	1-78
NTP- G158 Connect a Multishelf Node and Subtending Shelves to a Cisco Catalyst 2950	1-80
NTP- G159 Configure a Cisco Catalyst 2950 for a Multishelf Node	1-80
NTP- G16 Perform the Shelf Installation Acceptance Test	1-82
DLP- G35 Inspect the Shelf Installation and Connections	1-84
DLP- G36 Measure Voltage	1-84

CHAPTER 2**Connect the PC and Log into the GUI 2-1**

Before You Begin	2-1
NTP- G17 Set Up Computer for CTC	2-1
DLP- G37 Run the CTC Installation Wizard for Windows PCs	2-2
DLP- G38 Run the CTC Installation Wizard for Solaris Workstations	2-5
DLP- G52 Change the JRE Version	2-8
NTP- G18 Set Up CTC Computer for Local Craft Connection to the ONS 15454	2-9
DLP- G39 Set Up a Windows PC for Craft Connection to an ONS 15454 on the Same Subnet Using Static IP Addresses	2-11
DLP- G40 Set Up a Windows PC for Craft Connection to an ONS 15454 Using Dynamic Host Configuration Protocol	2-13
DLP- G41 Set Up a Windows PC for Craft Connection to an ONS 15454 Using Automatic Host Detection	2-16
DLP- G42 Set Up a Solaris Workstation for a Craft Connection to an ONS 15454	2-19
NTP- G19 Set Up a CTC Computer for a Corporate LAN Connection to the ONS 15454	2-21
DLP- G43 Disable or Bypass Proxy Service Using Internet Explorer (Windows)	2-22
DLP- G44 Disable or Bypass Proxy Service Using Netscape (Windows) or Mozilla (Solaris)	2-22
NTP- G21 Log into the ONS 15454 GUI	2-23
DLP- G331 Adjust the Java Virtual Memory Heap Size (Windows)	2-24
DLP- G46 Log into CTC	2-25
DLP- G47 Install Public-Key Security Certificate	2-28
DLP- G48 Create Login Node Groups	2-29
DLP- G49 Add a Node to the Current Session or Login Group	2-30
DLP- G50 Delete a Node from the Current Session or Login Group	2-31
DLP- G51 Delete a Node from a Specific Login Node Group	2-31
DLP- G53 Configure the CTC Alerts Dialog Box for Automatic Popup	2-32

CHAPTER 3

Turn Up a Node 3-1

- Before You Begin 3-1
- NTP- G139 Verify Cisco MetroPlanner Reports and Files 3-3
- NTP- G22 Verify Common Card Installation 3-4
- NTP- G144 Provision a Multishelf Node 3-5
- NTP- G23 Create Users and Assign Security 3-7
 - DLP- G54 Create a New User on a Single Node 3-8
 - DLP- G55 Create a New User on Multiple Nodes 3-9
- NTP- G24 Set Up Name, Date, Time, and Contact Information 3-10
- NTP- G25 Set Battery Power Monitor Thresholds 3-12
- NTP- G26 Set Up CTC Network Access 3-13
 - DLP- G56 Provision IP Settings 3-14
 - DLP- G57 Set the IP Address, Default Router, and Network Mask Using the LCD 3-16
 - DLP- G264 Enable Node Security Mode 3-18
 - DLP- G58 Create a Static Route 3-20
 - DLP- G59 Set Up or Change Open Shortest Path First Protocol 3-21
 - DLP- G60 Set Up or Change Routing Information Protocol 3-23
- NTP- G27 Set Up the ONS 15454 for Firewall Access 3-24
 - DLP- G61 Provision the IOP Listener Port on the ONS 15454 3-25
 - DLP- G62 Provision the IOP Listener Port on the CTC Computer 3-26
- NTP- G132 Provision OSI 3-27
 - DLP- G283 Provision OSI Routing Mode 3-28
 - DLP- G284 Provision the TARP Operating Parameters 3-29
 - DLP- G285 Add a Static TID to NSAP Entry to the TARP Data Cache 3-31
 - DLP- G287 Add a TARP Manual Adjacency Table Entry 3-32
 - DLP- G288 Provision OSI Routers 3-32
 - DLP- G289 Provision Additional Manual Area Addresses 3-33
 - DLP- G290 Enable the OSI Subnet on the LAN Interface 3-34
 - DLP- G291 Create an IP-Over-CLNS Tunnel 3-35
- NTP- G28 Set Up SNMP 3-36
- NTP- G143 Import the Cisco MetroPlanner NE Update Configuration File 3-38
 - DLP- G351 Delete a Card in CTC 3-41
 - DLP- G353 Preprovision a Single Slot 3-42
- NTP- G30 Install the DWDM Cards 3-44
 - DLP- G348 Use the Cisco MetroPlanner Shelf Layout Report 3-47
- NTP- G31 Install the DWDM Dispersion Compensating Units 3-49
- NTP- G32 Install the Transponder and Muxponder Cards 3-50
 - DLP- G63 Install an SFP or XFP 3-52

DLP-	G273 Preprovision an SFP or XFP Slot	3-53
DLP-	G64 Remove an SFP or XFP	3-54
NTP-	G123 Install the Filler Cards	3-55
NTP-	G34 Install Fiber-Optic Cables on DWDM Cards and DCUs	3-56
DLP-	G349 Use the Cisco MetroPlanner Internal Connections Report	3-58
NTP-	G140 Install Fiber-Optic Cables Between Terminal, Hub, or ROADM Node DWDM Cards and TXP/MXP Cards	3-62
DLP-	G315 Install Fiber-Optic Cables From the 32WSS/32DMX and 32MUX-O/32DMX-O Cards to the Standard Patch-Panel Tray	3-64
DLP-	G316 Install Fiber-Optic Cables from TXP/MXP Cards to the Standard Patch-Panel Tray	3-68
DLP-	G356 Install Fiber-Optic Cables from the 32WSS/32DMX and 32MUX-O/32DMX-O Cards to the Deep Patch-Panel Tray	3-69
DLP-	G357 Install Fiber-Optic Cables from the TXP/MXP Cards to the Deep Patch-Panel Tray	3-72
NTP-	G191 Install Fiber-Optic Cables on Passthrough ROADM Nodes	3-73
NTP-	G141 Install Fiber-Optic Cables for Y-Cable Protection Modules	3-75
DLP-	G375 Install Fiber-Optic Cables on the Y-Cable Modules in the FlexLayer Shelf	3-76
DLP-	G376 Install Fiber-Optic Cables on the Y-Cable Modules in the Y-Cable Module Tray	3-77
NTP-	G152 Create and Verify Internal Patchcords	3-80
DLP-	G354 Create an Internal Patchcord Manually	3-81
DLP-	G355 Delete an Internal Patchcord	3-82
NTP-	G37 Run Automatic Node Setup	3-82
NTP-	G38 Provision OSC Terminations	3-83
NTP-	G39 Verify OSCM Transmit Power	3-85
DLP-	G314 Verify OSCM Transmit Power	3-86
NTP-	G163 Upgrade Nodes in Single-Shelf Mode to Multishelf Mode	3-87

CHAPTER 4**Perform Node Acceptance Tests 4-1**

Before You Begin	4-1	
NTP-	G41 Perform the Terminal or Hub Node with 32MUX-O and 32DMX-O Cards Acceptance Test	4-2
DLP-	G268 Provision TXP_MR_10E_C Cards for Acceptance Testing	4-4
DLP-	G79 Verify the OPT-BST, OPT-BST-E, or OPT-BST-L Amplifier Laser and Power	4-5
DLP-	G80 Verify the OPT-PRE Amplifier Laser and Power	4-6
DLP-	G78 Verify the 32MUX-O Card Power	4-7
DLP-	G269 Verify the 32DMX-O Card Power	4-7
NTP-	G42 Perform the Terminal Node with 32WSS and 32DMX Cards Acceptance Test	4-8
DLP-	G270 Verify the 32DMX Power	4-12
NTP-	G153 Perform the Terminal Node with 32WSS-L and 32DMX-L Cards Acceptance Test	4-13
DLP-	G358 Provision TXP_MR_10E_L Card for Acceptance Testing	4-16

DLP- G359 Verify the OPT-BST-L or OPT-AMP-L (OPT-Line Mode) Amplifier Laser and Power	4-17
DLP- G360 Verify the OPT-AMP-L (OPT-PRE Mode) Amplifier Laser and Power	4-18
DLP- G361 Verify the 32DMX-L Power	4-19
NTP- G43 Perform the ROADM Node with 32WSS and 32DMX Cards Acceptance Test	4-20
DLP- G310 Verify ROADM Node C-Band Pass-Through Channels	4-24
DLP- G311 Verify the East ROADM C-Band Add/Drop Channels	4-32
DLP- G312 Verify the West ROADM C-Band Add/Drop Channels	4-37
NTP- G154 Perform the ROADM Node with 32WSS-L and 32DMX-L Cards Acceptance Test	4-42
DLP- G362 Verify ROADM Node L-Band Pass-Through Channels	4-46
DLP- G363 Verify the East ROADM L-Band Add/Drop Channels	4-54
DLP- G364 Verify the West ROADM L-Band Add/Drop Channels	4-59
NTP- G44 Perform the Anti-ASE Hub Node Acceptance Test	4-64
NTP- G45 Perform the C-Band Line Amplifier Node with OSCM Cards Acceptance Test	4-66
NTP- G155 Perform the L-Band Line Amplifier Node with OSCM Cards Acceptance Test	4-70
NTP- G46 Perform the C-Band Line Amplifier Node with OSC-CSM Cards Acceptance Test	4-74
NTP- G156 Perform the L-Band Line Amplifier Node with OSC-CSM Cards Acceptance Test	4-78
NTP- G47 Perform the C-Band Line Amplifier Node with OSCM and OSC-CSM Cards Acceptance Test	4-82
NTP- G157 Perform the L-Band Line Amplifier Node with OSCM and OSC-CSM Cards Acceptance Test	4-86
NTP- G48 Perform the OADM Node Acceptance Test on a Symmetric Node with OSCM Cards	4-90
DLP- G85 Verify Express Channel Connections on an OADM Node with OSCM Cards	4-92
DLP- G87 Verify the AD-xB-xx.x Output Express Power	4-93
DLP- G88 Verify the AD-xC-xx.x Output Express Power	4-93
DLP- G271 Verify the AD-xC-xx.x Output Common Power	4-94
DLP- G272 Verify the AD-xB-xx.x Output Common Power	4-94
DLP- G89 Verify OADM Node Pass-Through Channel Connections	4-94
DLP- G90 Verify an AD-xB-xx.x Pass-Through Connection Power	4-96
DLP- G91 Verify an AD-xC-xx.x Pass-Through Connection	4-96
DLP- G84 Verify the OSC-CSM Incoming Power	4-97
DLP- G93 Verify Add and Drop Connections on an OADM Node with OSCM Cards	4-98
DLP- G92 Verify 4MD-xx.x Pass-Through Connection Power	4-100
NTP- G49 Perform the OADM Active Node Acceptance Test on a Symmetric Node with OSC-CSM Cards	4-102
DLP- G86 Verify Express Channel Connections on an OADM Node with OSC-CSM Cards	4-104
DLP- G83 Verify the OSC-CSM Power on OADM Nodes	4-105
DLP- G94 Verify Add and Drop Connections on an OADM Node with OSC-CSM Cards	4-105
NTP- G50 Perform the OADM Passive Node Acceptance Test on a Symmetric Node with OSC-CSM Cards	4-108

DLP- G82 Verify the OSC-CSM Power 4-110

CHAPTER 5

Provision Transponder and Muxponder Cards 5-1

Before You Begin 5-1

NTP- G128 Manage Pluggable Port Modules 5-2

DLP- G235 Change the 2.5G Data Muxponder Card Mode 5-3

DLP- G332 Change the 10G Data Muxponder Port Mode 5-4

DLP- G277 Provision a Multirate PPM 5-6

DLP- G274 Verify Topologies for ETR_CLO and ISC Services 5-7

DLP- G278 Provision the Optical Line Rate 5-9

DLP- G280 Delete a PPM 5-12

NTP- G33 Create a Y-Cable Protection Group 5-14

NTP- G98 Provision the 2.5G Multirate Transponder Card Line Settings and PM Parameter Thresholds 5-17

DLP- G229 Change the 2.5G Multirate Transponder Card Settings 5-18

DLP- G230 Change the 2.5G Multirate Transponder Line Settings 5-19

DLP- G231 Change the 2.5G Multirate Transponder Line Section Trace Settings 5-22

DLP- G367 Change the 2.5G Multirate Transponder Trunk Wavelength Settings 5-23

DLP- G232 Change the 2.5G Multirate Transponder SONET or SDH Line Threshold Settings 5-24

DLP- G320 Change the 2.5G Multirate Transponder Line RMON Thresholds for 1G Ethernet or 1G FC/FICON Payloads 5-27

DLP- G305 Provision the 2.5G Multirate Transponder Trunk Port Alarm and TCA Thresholds 5-28

DLP- G306 Provision the 2.5G Multirate Transponder Client Port Alarm and TCA Thresholds 5-30

DLP- G234 Change the 2.5G Multirate Transponder OTN Settings 5-34

NTP- G96 Provision the 10G Multirate Transponder Card Line Settings, PM Parameters, and Thresholds 5-37

DLP- G365 Provision the TXP_MR_10G Data Rate 5-38

DLP- G216 Change the 10G Multirate Transponder Card Settings 5-38

DLP- G217 Change the 10G Multirate Transponder Line Settings 5-40

DLP- G218 Change the 10G Multirate Transponder Line Section Trace Settings 5-43

DLP- G368 Change the 10G Multirate Transponder Trunk Wavelength Settings 5-44

DLP- G219 Change the 10G Multirate Transponder Line Thresholds for SONET or SDH Payloads Including 10G Ethernet WAN Phy 5-45

DLP- G319 Change the 10G Multirate Transponder Line RMON Thresholds for 10G Ethernet LAN Phy Payloads 5-48

DLP- G301 Provision the 10G Multirate Transponder Trunk Port Alarm and TCA Thresholds 5-51

DLP- G302 Provision the 10G Multirate Transponder Client Port Alarm and TCA Thresholds 5-52

DLP- G221 Change the 10G Multirate Transponder OTN Settings 5-54

NTP- G97 Modify the 4x2.5G Muxponder Card Line Settings and PM Parameter Thresholds 5-58

DLP- G222 Change the 4x2.5G Muxponder Card Settings 5-59

DLP- G223	Change the 4x2.5G Muxponder Line Settings	5-61
DLP- G224	Change the 4x2.5G Muxponder Section Trace Settings	5-64
DLP- G225	Change the 4x2.5G Muxponder Trunk Settings	5-65
DLP- G369	Change the 4x2.5G Muxponder Trunk Wavelength Settings	5-67
DLP- G226	Change the 4x2.5G Muxponder SONET/SDH Line Thresholds Settings	5-68
DLP- G303	Provision the 4x2.5G Muxponder Trunk Port Alarm and TCA Thresholds	5-71
DLP- G304	Provision the 4x2.5G Muxponder Client Port Alarm and TCA Thresholds	5-73
DLP- G228	Change the 4x2.5G Muxponder Line OTN Settings	5-75
NTP- G99	Modify the 2.5G Data Muxponder Card Line Settings and PM Parameter Thresholds	5-79
DLP- G236	Change the 2.5G Data Muxponder Client Line Settings	5-80
DLP- G237	Change the 2.5G Data Muxponder Distance Extension Settings	5-83
DLP- G238	Change the 2.5G Data Muxponder SONET (OC-48)/SDH (STM-16) Settings	5-85
DLP- G239	Change the 2.5G Data Muxponder Section Trace Settings	5-87
DLP- G370	Change the 2.5G Data Muxponder Trunk Wavelength Settings	5-89
DLP- G240	Change the 2.5G Data Muxponder SONET or SDH Line Thresholds	5-90
DLP- G321	Change the 2.5G Data Muxponder Line Thresholds for 1G Ethernet or 1G FC/FICON Payloads	5-92
DLP- G307	Provision the 2.5G Data Muxponder Trunk Port Alarm and TCA Thresholds	5-94
DLP- G308	Provision the 2.5G Data Muxponder Client Port Alarm and TCA Thresholds	5-95
NTP- G148	Modify the 10G Data Muxponder Card Line Settings and PM Parameter Thresholds	5-97
DLP- G333	Change the 10G Data Muxponder Client Line Settings	5-99
DLP- G334	Change the 10G Data Muxponder Distance Extension Settings	5-101
DLP- G340	Change the 10G Data Muxponder Trunk Wavelength Settings	5-102
DLP- G335	Change the 10G Data Muxponder SONET (OC-192)/SDH (STM-64) Settings	5-103
DLP- G336	Change the 10G Data Muxponder Section Trace Settings	5-105
DLP- G341	Change the 10G Data Muxponder SONET or SDH Line Thresholds	5-106
DLP- G337	Change the 10G Data Muxponder Line RMON Thresholds for Ethernet, 1G FC/FICON, or ISC/ISC3 Payloads	5-108
DLP- G338	Provision the 10G Data Muxponder Trunk Port Alarm and TCA Thresholds	5-111
DLP- G339	Provision the 10G Data Muxponder Client Port Alarm and TCA Thresholds	5-112
DLP- G366	Change the 10G Data Muxponder OTN Settings	5-115
NTP- G162	Change the TXP or MXP ALS Maintenance Settings	5-117

CHAPTER 6

Turn Up a Network 6-1

Before You Begin	6-1
NTP- G51	Verify DWDM Node Turn-Up 6-2
NTP- G52	Verify Node-to-Node Connections 6-3
NTP- G53	Set Up Timing 6-4
DLP- G95	Set Up External or Line Timing 6-4

DLP- G96 Set Up Internal Timing	6-7
DLP- G350 Use the Cisco MetroPlanner Traffic Matrix Report	6-8
NTP- G54 Provision and Verify a DWDM Network	6-10
NTP- G56 Verify the OSNR	6-14
NTP- G142 Perform a Protection Switch Test	6-15
NTP- G57 Create a Logical Network Map	6-18

CHAPTER 7**Create Channels and Circuits 7-1**

Before You Begin	7-1
NTP- G151 Create and Delete Optical Channel Client Connections	7-2
DLP- G104 Assign a Name to a Port	7-3
DLP- G345 Verify OCHCC Client Ports	7-3
DLP- G346 Provision Optical Channel Client Connections	7-4
DLP- G347 Delete Optical Channel Client Connections	7-8
DLP- G424 Edit an OCHCC Circuit Name	7-9
DLP- G425 Edit an OCH Trail Circuit Name	7-10
NTP- G59 Create and Delete Optical Channel Network Connections	7-10
DLP- G105 Provision Optical Channel Network Connections	7-11
DLP- G106 Delete Optical Channel Network Connections	7-13
DLP- G426 Edit an OCHNC Circuit Name	7-15
NTP- G150 Upgrade Optical Channel Network Connections to Optical Channel Client Connections	7-15
DLP- G344 Verify Provisionable Patchcords	7-18
DLP- G99 Create a Provisionable Patchcord	7-20
NTP- G60 Create and Delete Overhead Circuits	7-21
DLP- G76 Provision DCC/GCC Terminations	7-22
DLP- G97 Provision a Proxy Tunnel	7-24
DLP- G98 Provision a Firewall Tunnel	7-25
DLP- G108 Change the Service State for a Port	7-25
DLP- G109 Provision Orderwire	7-26
DLP- G110 Create a User Data Channel Circuit	7-28
DLP- G112 Delete Overhead Circuits	7-29
NTP- G62 Create a JO Section Trace	7-29
NTP- G58 Locate and View Optical Channel Network and Client Connections	7-30
DLP- G100 Search for Optical Channel Network and Client Connections	7-31
DLP- G101 View Optical Channel Network and Client Connection Information	7-32
DLP- G102 Filter the Display of Optical Channel Network and Client Connections	7-35
DLP- G103 View Optical Channel Network Connections on a Span	7-37

CHAPTER 8

Manage Alarms 8-1

- Before You Begin 8-1
- NTP- G63 Document Existing Provisioning 8-2
 - DLP- G113 Print CTC Data 8-2
 - DLP- G114 Export CTC Data 8-4
- NTP- G64 View Alarms, History, Events, and Conditions 8-6
 - DLP- G115 View Alarms 8-7
 - DLP- G116 View Alarm or Event History 8-8
 - DLP- G117 Change the Maximum Number of Session Entries for Alarm History 8-10
 - DLP- G118 Display Alarms and Conditions Using Time Zone 8-11
 - DLP- G119 Synchronize Alarms 8-12
 - DLP- G120 View Conditions 8-12
- NTP- G65 Delete Cleared Alarms from Display 8-14
- NTP- G66 View Alarm-Affected Circuits 8-15
- NTP- G67 View Alarm Counts on the LCD for a Node, Slot, or Port 8-15
- NTP- G68 Create, Download, and Assign Alarm Severity Profiles 8-17
 - DLP- G121 Create a New or Cloned Alarm Severity Profile 8-17
 - DLP- G122 Download an Alarm Severity Profile 8-20
 - DLP- G123 Apply Alarm Profiles to Ports 8-21
 - DLP- G124 Apply Alarm Profiles to Cards and Nodes 8-23
 - DLP- G125 Delete Alarm Severity Profiles 8-23
- NTP- G69 Enable, Modify, or Disable Alarm Severity Filtering 8-25
 - DLP- G126 Enable Alarm Filtering 8-26
 - DLP- G127 Modify Alarm, Condition, and History Filtering Parameters 8-26
 - DLP- G128 Disable Alarm Filtering 8-28
- NTP- G70 Suppress Alarms or Discontinue Alarm Suppression 8-29
 - DLP- G129 Suppress Alarm Reporting 8-29
 - DLP- G130 Discontinue Alarm Suppression 8-31
- NTP- G72 Provision External Alarms and Controls on the Alarm Interface Controller-International Card 8-32

CHAPTER 9

Monitor Performance 9-1

- Before You Begin 9-1
- NTP- G73 Change the PM Display 9-2
 - DLP- G131 Refresh PM Counts at 15-Minute Intervals 9-2
 - DLP- G132 Refresh PM Counts at One-Day Intervals 9-3
 - DLP- G133 View Near-End PM Counts 9-4
 - DLP- G134 View Far-End PM Counts 9-5

DLP- G135 Reset Current PM Counts	9-6
DLP- G136 Clear Selected PM Counts	9-7
DLP- G137 Set Auto-Refresh Interval for Displayed PM Counts	9-8
DLP- G138 Refresh PM Counts for a Different Port	9-9
NTP- G74 Monitor DWDM Card Performance	9-9
DLP- G139 View Optical Service Channel PM Parameters	9-10
DLP- G140 View Optical Amplifier Power Statistics	9-12
DLP- G141 View Optical Power Statistics for 32MUX-O, 32WSS, 32WSS-L, 32DMX-O, 32DMX, and 32DMX-L Cards	9-13
DLP- G276 View 4-Channel Multiplexer/Demultiplexer Optical Power Statistics	9-15
DLP- G142 View Channel Optical Add/Drop Multiplexer Power Statistics	9-16
DLP- G143 View Band Optical Add/Drop Multiplexer Power Statistics	9-18
NTP- G75 Monitor Transponder and Muxponder Performance	9-19
DLP- G144 Enable or Disable OTN ITU-T G.709 Performance Monitoring	9-20
DLP- G145 Enable or Disable OTN FEC Performance Monitoring	9-21
DLP- G146 View Optics PM Parameters	9-22
DLP- G147 View Payload PM Parameters	9-23
DLP- G148 View OTN PM Parameters	9-25
DLP- G149 View Payload Statistics PM Parameters	9-27
DLP- G150 View Payload Utilization PM Parameters	9-29
DLP- G151 View Payload History PM Parameters	9-30
DLP- G152 View Payload SONET/SDH PM Parameters	9-32

CHAPTER 10**Manage the Node 10-1**

Before You Begin	10-1
NTP- G76 Verify Optical Span Loss Using CTC	10-2
NTP- G77 Manage Automatic Power Control	10-3
DLP- G157 Disable Automatic Power Control	10-4
DLP- G158 Enable Automatic Power Control	10-4
DLP- G159 Refresh Automatic Power Control Information	10-5
NTP- G78 View ROADM Node Power Equalization	10-5
NTP- G80 Change Node Management Information	10-6
DLP- G160 Change the Node Name, Date, Time, and Contact Information	10-7
DLP- G161 Change the Login Legal Disclaimer	10-8
NTP- G134 Modify OSI Provisioning	10-9
DLP- G284 Modify the TARP Operating Parameters	10-10
DLP- G286 Remove a Static TID to NSAP Entry from the TARP Data Cache	10-12
DLP- G287 Add a TARP Manual Adjacency Table Entry	10-12
DLP- G292 Remove a TARP Manual Adjacency Table Entry	10-13

- DLP- G293 Change the OSI Routing Mode 10-14
- DLP- G294 Edit the OSI Router Configuration 10-15
- DLP- G295 Edit the OSI Subnetwork Point of Attachment 10-16
- DLP- G296 Edit an IP-Over-CLNS Tunnel 10-17
- DLP- G297 Delete an IP-Over-CLNS Tunnel 10-18
- NTP- G81 Change CTC Network Access 10-18
 - DLP- G162 Change IP Settings 10-19
 - DLP- G265 Lock Node Security 10-20
 - DLP- G266 Modify Backplane Port IP Settings in Security Mode 10-21
 - DLP- G267 Disable Node Security Mode 10-22
 - DLP- G163 Modify a Static Route 10-23
 - DLP- G164 Delete a Static Route 10-24
 - DLP- G165 Disable OSPF 10-24
 - DLP- G166 Delete a Proxy Tunnel 10-25
 - DLP- G167 Delete a Firewall Tunnel 10-25
- NTP- G82 Customize the CTC Network View 10-26
 - DLP- G168 Change the Network View Background Color 10-26
 - DLP- G169 Change the Default Network View Background Map 10-27
 - DLP- G170 Apply a Custom Network View Background Map 10-28
 - DLP- G171 Create Domain Icons 10-28
 - DLP- G172 Manage Domain Icons 10-29
 - DLP- G173 Enable Dialog Box Do-Not-Display Option 10-30
 - DLP- G174 Switch Between TDM and DWDM Network Views 10-31
 - DLP- G330 Consolidate Links in Network View 10-31
- NTP- G83 Modify or Delete Card Protection Settings 10-34
 - DLP- G175 Modify a Y-Cable Protection Group 10-35
 - DLP- G176 Modify a Splitter Protection Group 10-35
 - DLP- G177 Delete a Y-Cable Protection Group 10-36
- NTP- G84 Initiate and Clear Y-Cable and Splitter External Switching Commands 10-37
 - DLP- G178 Apply a Manual Y-Cable or Splitter Protection Switch 10-38
 - DLP- G179 Apply a Force Y-Cable or Splitter Protection Switch 10-38
 - DLP- G180 Clear a Manual or Force Y-Cable or Splitter Protection Switch 10-39
 - DLP- G181 Apply a Lock-On 10-40
 - DLP- G182 Apply a Lockout 10-40
 - DLP- G183 Clear a Lock-On or Lockout 10-41
- NTP- G85 Modify or Delete OSC Terminations, DCC/GCC Terminations, and Provisionable Patchcords 10-42
 - DLP- G184 Change a DCC/GCC Termination 10-43
 - DLP- G185 Delete a DCC/GCC Termination 10-43

DLP- G186 Delete an OSC Termination	10-44
DLP- G187 Delete a Provisionable Patchcord	10-45
NTP- G86 Convert a Pass-Through Connection to Add/Drop Connections	10-45
NTP- G87 Change Node Timing Parameters	10-47
NTP- G88 Modify Users and Change Security	10-48
DLP- G188 Change Security Policy for a Single Node	10-49
DLP- G189 Change Security Policy for Multiple Nodes	10-50
DLP- G317 Change Node Access and PM Clearing Privilege	10-52
DLP- G328 Grant Superuser Privileges to a Provisioning User	10-53
DLP- G191 Change User Password and Security Level on a Single Node	10-54
DLP- G192 Change User Password and Security Level for Multiple Nodes	10-55
DLP- G193 Delete a User From a Single Node	10-55
DLP- G194 Delete a User From Multiple Nodes	10-56
DLP- G195 Log Out a User on a Single Node	10-57
DLP- G196 Log Out a User on Multiple Nodes	10-58
DLP- G281 Configure the Node for RADIUS Authentication	10-58
DLP- G282 View and Terminate Active Logins	10-61
NTP- G131 Convert DWDM Nodes to Hybrid Nodes	10-61
NTP- G89 Change SNMP Settings	10-64
DLP- G197 Modify SNMP Trap Destinations	10-65
DLP- G198 Delete SNMP Trap Destinations	10-66

CHAPTER 11**Change DWDM Card Settings 11-1**

Before You Begin	11-1
NTP- G90 Modify OSCM and OSC-CSM Card Line Settings and PM Thresholds	11-2
DLP- G199 Change the OSCM and OSC-CSM Optical Service Channel Settings	11-2
DLP- G200 Change the OSCM and OSC-CSM Optical Service Channel Thresholds	11-5
DLP- G201 Change Optical Line Parameters for OSCM and OSC-CSM Cards	11-6
DLP- G202 Change the OSCM and OSC-CSM Optical Line Threshold Settings	11-8
DLP- G203 Change the OSCM and OSC-CSM ALS Maintenance Settings	11-12
NTP- G91 Modify OPT-PRE and OPT-BST Card Line Settings and PM Thresholds	11-13
DLP- G204 Change Optical Line Settings for OPT-PRE and OPT-BST Amplifiers	11-14
DLP- G205 Change Optical Line Threshold Settings for OPT-PRE and OPT-BST Amplifiers	11-15
DLP- G206 Change Optical Amplifier Line Settings for OPT-PRE and OPT-BST Amplifiers	11-18
DLP- G207 Change Optical Amplifier Threshold Settings for OPT-PRE and OPT-BST Amplifiers	11-20
DLP- G322 Change the OPT-BST ALS Maintenance Settings	11-24
NTP- G160 Modify OPT-AMP-L Card Line Settings and PM Thresholds	11-25
DLP- G323 Change Optical Line Settings for OPT-AMP-L Amplifiers	11-26
DLP- G324 Change Optical Line Threshold Settings for OPT-AMP-L Amplifiers	11-28

- DLP- G325 Change Optical Amplifier Line Settings for OPT-AMP-L Amplifiers 11-30
- DLP- G326 Change Optical Amplifier Threshold Settings for OPT-AMP-L Amplifiers 11-32
- DLP- G327 Change the ALS Maintenance Settings of an OPT-AMP-L Card Configured in OPT-LINE Mode 11-36
- NTP- G92 Modify 32MUX-O, 32DMX-O, 32DMX, 32DMX-L, and 4MD Line Card Settings and PM Thresholds 11-38
 - DLP- G208 Change Optical Line Settings for Multiplexer and Demultiplexer Cards 11-39
 - DLP- G209 Change Optical Line Threshold Settings for Multiplexer and Demultiplexer Cards 11-41
 - DLP- G210 Change Optical Channel Settings for Multiplexer and Demultiplexer Cards 11-43
 - DLP- G211 Change Optical Channel Threshold Settings for Multiplexer and Demultiplexer Cards 11-45
- NTP- G93 Modify the 32WSS and 32WSS-L Line Settings and PM Thresholds 11-48
 - DLP- G212 Change 32WSS and 32WSS-L Optical Channel Parameters 11-49
 - DLP- G213 Change the 32WSS and 32WSS-L Optical Channel Thresholds 11-52
 - DLP- G214 Change 32WSS and 32WSS-L Optical Line Parameters 11-55
 - DLP- G215 Change the 32WSS and 32-WSS-L Optical Line Thresholds 11-56
- NTP- G149 Modify the MMU Line Settings and PM Thresholds 11-58
 - DLP- G342 Change MMU Optical Line Parameters 11-59
 - DLP- G343 Change the MMU Optical Line Thresholds 11-60
- NTP- G101 Modify Alarm Interface Controller–International Settings 11-62
 - DLP- G245 Change External Alarms Using the AIC-I Card 11-63
 - DLP- G246 Change External Controls Using the AIC-I Card 11-64
 - DLP- G247 Change AIC-I Card Orderwire Settings 11-64
- NTP- G102 Change Card Service State 11-65

CHAPTER 12

Add and Remove Cards and Nodes 12-1

- Before You Begin 12-1
- NTP- G107 Permanently Remove or Remove and Replace DWDM Cards 12-2
 - DLP- G254 Place OPT-BST, OPT-BST-E, OPT-BST-L, and OPT-PRE Ports Out of Service 12-4
 - DLP- G318 Place OPT-BST, OPT-BST-E, OPT-BST-L, and OPT-PRE Ports In Service 12-5
- NTP- G127 Add an AD-xC-xx.x Card to an OADM Node 12-5
- NTP- G129 Add a DWDM Node 12-8
- NTP- G130 Remove a DWDM Node 12-10
- NTP- G146 Add a Rack and/or Shelf to a Multishelf Node 12-13
- NTP- G147 Delete a Shelf and/or Rack from a Multishelf Node 12-14

CHAPTER 13

Maintain the Node 13-1

- Before You Begin 13-1

NTP- G103 Back Up the Database	13-2
NTP- G104 Restore the Database	13-3
NTP- G105 Restore the Node to Factory Configuration	13-4
DLP- G248 Use the Reinitialization Tool to Clear the Database and Upload Software (Windows)	13-5
DLP- G249 Use the Reinitialization Tool to Clear the Database and Upload Software (UNIX)	13-7
NTP- G133 View and Manage OSI Information	13-9
DLP- G298 View IS-IS Routing Information Base	13-9
DLP- G299 View ES-IS Routing Information Base	13-10
DLP- G300 Manage the TARP Data Cache	13-11
NTP- G106 Reset Cards Using CTC	13-12
DLP- G250 Reset the TCC2/TCC2P Card	13-12
DLP- G251 Reset DWDM Cards Using CTC	13-13
NTP- G108 Viewing the Audit Trail Records	13-14
NTP- G109 Off-Load the Audit Trail Record	13-16
NTP- G110 Off-Load the Diagnostics File	13-17
NTP- G112 Change the Node Timing Reference	13-17
DLP- G259 Manual or Force Switch the Node Timing Reference	13-18
DLP- G260 Clear a Manual or Force Switch on a Node Timing Reference	13-19
NTP- G113 View the ONS 15454 Timing Report	13-19
NTP- G114 Inspect, Clean, and Replace the Air Filter	13-22
NTP- G115 Clean Fiber Connectors	13-25
DLP- G261 Clean Multi Fiber-Optic Cable Connectors	13-26
DLP- G262 Clean Fiber Connectors with CLETOP	13-27
DLP- G263 Clean the Fiber Adapters	13-27
NTP- G40 Replace the Front Door	13-28
NTP- G116 Replace the Fan-Tray Assembly	13-30
NTP- G117 Replace the ANSI Shelf Alarm Interface Panel	13-35
NTP- G118 Replace the ANSI Shelf Plastic Lower Backplane Cover	13-39
NTP- G135 Edit Network Element Defaults	13-41
NTP- G136 Import Network Element Defaults	13-42
NTP- G137 Export Network Element Defaults	13-43

CHAPTER 14**Power Down a Node 14-1**

NTP- G119 Power Down the Node	14-1
-------------------------------	------

APPENDIX A **CTC Information and Shortcuts** A-1

INDEX



<i>Figure 1-1</i>	Reversing the Mounting Brackets (23-inch [584.2-mm] Position to 19-inch [482.6-mm] Position)	1-11
<i>Figure 1-2</i>	Installing the External Brackets	1-12
<i>Figure 1-3</i>	Mounting an ONS 15454 ETSI in a Rack	1-14
<i>Figure 1-4</i>	Three-Shelf ONS 15454 ETSI (15454 SDH) Bay Assembly	1-18
<i>Figure 1-5</i>	Mounting the Air Ramp in a Rack	1-19
<i>Figure 1-6</i>	Cisco ONS 15454 ANSI Front Door	1-21
<i>Figure 1-7</i>	Removing the ONS 15454 ETSI Front Door	1-22
<i>Figure 1-8</i>	Removing the ONS 15454 ANSI Front Door	1-23
<i>Figure 1-9</i>	Unscrewing the FMEC Cover	1-24
<i>Figure 1-10</i>	Removing the ONS 15454 FMEC Cover	1-25
<i>Figure 1-11</i>	Backplane Covers on the 15454 ANSI Shelf	1-26
<i>Figure 1-12</i>	Lower Backplane Cover	1-27
<i>Figure 1-13</i>	Installing FMECs on the ONS 15454 ETSI	1-29
<i>Figure 1-14</i>	Grounding the ONS 15454 ETSI	1-33
<i>Figure 1-15</i>	Ground Location on the Backplane	1-34
<i>Figure 1-16</i>	Cisco ONS 15454 Power Terminals	1-37
<i>Figure 1-17</i>	Installing the Fan-Tray Assembly on the ONS 15454 ETSI	1-41
<i>Figure 1-18</i>	Installing the Fan-Tray Assembly on the ONS 15454 ANSI	1-42
<i>Figure 1-19</i>	Replace Backplane Screws with Standoffs	1-44
<i>Figure 1-20</i>	Installing Standoffs and the AEP	1-45
<i>Figure 1-21</i>	AEP Wire-Wrap Connections to Backplane Pins	1-45
<i>Figure 1-22</i>	Cisco ONS 15454 Backplane Pinouts (Release 3.4 or Later)	1-53
<i>Figure 1-23</i>	Highlighted Environmental Alarms	1-54
<i>Figure 1-24</i>	Installing the AEP Cover	1-58
<i>Figure 1-25</i>	Alarm Input Connector	1-60
<i>Figure 1-26</i>	Alarm Output Connector	1-61
<i>Figure 1-27</i>	ONS 15454 ETSI FMEC Cover	1-62
<i>Figure 1-28</i>	Backplane Attachment for the Rear Cover	1-63
<i>Figure 1-29</i>	Installing the Rear Cover with Spacers	1-64
<i>Figure 1-30</i>	ONS 15xxx FlexLayer Shelf Assembly	1-70
<i>Figure 1-31</i>	Y-Cable Module	1-71

Figure 1-32	Connecting the EAP to the Node Controller and Subtending Shelf	1-79
Figure 2-1	Logging into CTC	2-27
Figure 2-2	Login Node Group	2-30
Figure 3-1	Cisco MetroPlanner Shelf Layout	3-4
Figure 3-2	Selecting the IP Address Option	3-16
Figure 3-3	Changing the IP Address	3-16
Figure 3-4	Selecting the Save Configuration Option	3-17
Figure 3-5	Saving and Rebooting the TCC2/TCC2P	3-17
Figure 3-6	Nodes Behind a Firewall	3-24
Figure 3-7	CTC Computer and ONS 15454 Nodes Residing Behind Firewalls	3-25
Figure 3-8	Creating an SNMP Trap	3-37
Figure 3-9	Cisco MetroPlanner Shelf Layout Report Displayed in Cisco MetroPlanner	3-48
Figure 3-10	Managing Cables on the Front Panel	3-57
Figure 3-11	Fiber-Storage Tray	3-57
Figure 3-12	Cisco MetroPlanner Internal Connections Report - Patchcord Installation View	3-60
Figure 3-13	Cisco MetroPlanner Internal Connections Report - SW Provisioning View	3-60
Figure 3-14	Using the Patch-Panel Latches to Slide the Patch Panel Away from the Tray	3-65
Figure 3-15	MPO Cable	3-66
Figure 3-16	Rear View of the Patch Panel	3-67
Figure 3-17	Top View of the Patch-Panel Bar	3-67
Figure 3-18	Front View of the Patch Panel	3-68
Figure 3-19	Deep Patch-Panel Tray	3-70
Figure 3-20	Deep Patch-Panel Port Wavelengths	3-71
Figure 3-21	Managing Cables on the Front Panel	3-74
Figure 3-22	Fiber-Storage Tray	3-74
Figure 3-23	Y-Cable Protection Port Label	3-78
Figure 3-24	Y-Cable Protection Module Tray	3-79
Figure 3-25	OSC Terminations Area	3-84
Figure 5-1	Single-Span Topology	5-7
Figure 5-2	Point-to-Point Topology	5-8
Figure 5-3	Hubs with No Line Amplifiers	5-8
Figure 5-4	Hubs with Line Amplifiers	5-8
Figure 5-5	Creating a Y-Cable Protection Group	5-16
Figure 6-1	Cisco MetroPlanner Traffic Matrix Report	6-8
Figure 6-2	Maintenance > Protection Tabs	6-17

Figure 7-1	OCHCC Attributes Page	7-6
Figure 7-2	Upgrade OCHNC Initialization—Completed	7-17
Figure 7-3	Upgrade OCHNC Initialization—Failed	7-17
Figure 7-4	Upgrade OCHNC Dialog Box	7-18
Figure 7-5	Viewing the Provisionable Patchcords Table	7-19
Figure 7-6	Create Provisionable Patchcord - Single Shelf to Single Shelf	7-21
Figure 8-1	Selecting CTC Data For Print	8-3
Figure 8-2	Selecting CTC Data For Export	8-5
Figure 8-3	CTC Preferences Dialog Box	8-11
Figure 8-4	Shelf LCD Panel	8-16
Figure 8-5	Store Profiles Dialog Box	8-19
Figure 8-6	AD-1C Card Alarm Profile	8-22
Figure 8-7	Select Node/Profile Combination For Delete Dialog Box	8-24
Figure 8-8	Alarm Filter Dialog Box General Tab	8-27
Figure 8-9	Alarm Filter Dialog Box Conditions Tab	8-27
Figure 8-10	Provisioning External Alarms on the AIC-I Card	8-33
Figure 9-1	OC3 Line Tab in the Optical Service Channel Card View Performance Window	9-11
Figure 9-2	Optical Line Tab in the Optical Amplifier Card View Performance Window	9-12
Figure 9-3	Optical Channel Tab in the Multiplexer/Demultiplexer Card View Performance Window	9-14
Figure 9-4	Optical Channel Tab in the 4MD-xx.x Card View Performance Window	9-15
Figure 9-5	Optical Line Tab in the Channel Filter OADM Card View Performance Window	9-17
Figure 9-6	Viewing Optics Performance Monitoring Information	9-23
Figure 9-7	Viewing Payload Performance Monitoring Information	9-24
Figure 9-8	Viewing OTN ITU-T G.709 Performance Monitoring Information	9-26
Figure 9-9	Viewing OTN FEC Performance Monitoring Information	9-27
Figure 9-10	Statistics Tab on the Card View Performance Window	9-28
Figure 9-11	Utilization Tab on the Card View Performance Window	9-29
Figure 9-12	History Tab on the Card View Performance Window	9-31
Figure 9-13	SONET PM Tab on the Card View Performance Window	9-32
Figure 10-1	Equalized ROADM Power Example	10-6
Figure 10-2	Unconsolidated Links in the Network View	10-32
Figure 10-3	Consolidated Links in the Network View	10-33
Figure 10-4	Network View with Local Link Consolidation	10-33
Figure 10-5	RADIUS Server Tab	10-59
Figure 10-6	Create RADIUS Server Entry Window	10-60

<i>Figure 13-1</i>	Restoring the Database—In-Process Notification	13-3
<i>Figure 13-2</i>	Reinitialization Tool	13-6
<i>Figure 13-3</i>	Viewing the Audit Trail Records	13-15
<i>Figure 13-4</i>	ANSI Shelf Fan-Tray Air Filter in an External Filter Bracket (Front Door Removed)	13-23
<i>Figure 13-5</i>	ETSI Shelf Fan-Tray Air Filter in an External Filter Bracket (Front Door Removed)	13-24
<i>Figure 13-6</i>	Installing the Door Ground Strap Retrofit Kit	13-28
<i>Figure 13-7</i>	Shelf Assembly with Door Ground Strap Retrofit Kit Installed (ANSI)	13-29
<i>Figure 13-8</i>	Removing or Replacing the Fan-Tray Assembly (Front Door Removed) (ANSI)	13-33
<i>Figure 13-9</i>	Removing or Replacing the Fan-Tray Assembly (Front Door Removed) (ETSI)	13-34
<i>Figure 13-10</i>	Find the MAC Address	13-36
<i>Figure 13-11</i>	Repairing Circuits	13-38
<i>Figure 13-12</i>	Recording the Old MAC Address Before Replacing the AIP	13-38
<i>Figure 13-13</i>	Circuit Repair Information	13-39
<i>Figure 13-14</i>	Attaching Plastic Lower Backplane Cover	13-40



TABLES

<i>Table 1-1</i>	Pin Connection of the Power FMECs	1-36
<i>Table 1-2</i>	Pin Assignments for the AEP	1-46
<i>Table 1-3</i>	Alarm Pin Assignments	1-48
<i>Table 1-4</i>	MIC-C/T/P Clock Connector Pin Assignment	1-50
<i>Table 1-5</i>	LAN Pin Assignments	1-51
<i>Table 1-6</i>	External Timing Pin Assignments for BITS	1-54
<i>Table 1-7</i>	LAN Pin Assignments for the ONS 15454 ANSI Shelf	1-55
<i>Table 1-8</i>	Craft Interface Pin Assignments	1-57
<i>Table 1-9</i>	Alarm Input Pin Assignments	1-58
<i>Table 1-10</i>	Alarm Output Pin Assignments	1-59
<i>Table 1-11</i>	ONS 15xxx FlexLayer Hardware Part Numbers	1-69
<i>Table 1-12</i>	ONS 15454 ETSI Shelf Installation Task Summary	1-82
<i>Table 1-13</i>	ONS 15454 ANSI Shelf Installation Task Summary	1-83
<i>Table 2-1</i>	CTC Computer Setup for Local Craft Connections to the ONS 15454	2-10
<i>Table 3-1</i>	Cisco MetroPlanner Node Setup Information and Files	3-3
<i>Table 3-2</i>	CTC Add Card Shortcut Menu for DWDM Cards	3-43
<i>Table 3-3</i>	Cable Connections for Y-Cable Protection of One Client Signal	3-76
<i>Table 3-4</i>	Cable Connections for Y-Cable Protection of a Second Client Signal	3-76
<i>Table 4-1</i>	32WSS Ports and Wavelengths Test Checklist	4-21
<i>Table 4-2</i>	32WSS-L Ports and Wavelengths Test Checklist	4-43
<i>Table 5-1</i>	2.5G Data Muxponder Card Settings	5-4
<i>Table 5-2</i>	10G Data Muxponder Card Settings	5-5
<i>Table 5-3</i>	PPM Port Types	5-10
<i>Table 5-4</i>	Protection Types	5-15
<i>Table 5-5</i>	TXP_MR_2.5G and TXPP_MR_2.5G Transponder Card Settings	5-19
<i>Table 5-6</i>	TXP_MR_2.5G and TXPP_MR_2.5G Transponder Card Line Settings	5-20
<i>Table 5-7</i>	TXP_MR_2.5G and TXPP_MR_2.5G Transponder Card Section Trace Settings	5-22
<i>Table 5-8</i>	TXP_MR_2.5G and TXPP_MR_2.5G Card Wavelength Trunk Settings	5-24
<i>Table 5-9</i>	TXP_MR_2.5G and TXPP_MR_2.5G Transponder Card Line Thresholds Settings for OC-3/STM-1, OC-12/STM-4, and OC-48/STM-16 Payloads	5-25
<i>Table 5-10</i>	TXP_MR_2.5G and TXPP_MR_2.5G Card 1G Ethernet and 1G FC/FICON Thresholds	5-27

Table 5-11	2R and 3R Mode and ITU-T G.709 Compliance by Client Interface	5-28
Table 5-12	TXP_MR_2.5G and TXPP_MR_2.5G Trunk Port TCA Thresholds	5-29
Table 5-13	TXP_MR_2.5G and TXPP_MR_2.5G Card Client Interface TCA Thresholds	5-30
Table 5-14	TXP_MR_2.5G and TXPP_MR_2.5G Card Client Interface Alarm Thresholds	5-32
Table 5-15	TXP_MR_2.5G and TXPP_MR_2.5G Transponder Card OTN Line Settings	5-34
Table 5-16	TXP_MR_2.5G and TXPP_MR_2.5G Transponder Card ITU-T G.709 Threshold Settings	5-35
Table 5-17	TXP_MR_2.5G and TXPP_MR_2.5G Transponder Card FEC Threshold Settings	5-35
Table 5-18	TXP_MR_2.5G and TXPP_MR_2.5G Transponder Card Trail Trace Identifier Settings	5-36
Table 5-19	TXP_MR_10G, TXP_MR_10E, TXP_MR_10E_C, or TXP_MR_10E_L Card Settings	5-39
Table 5-20	TXP_MR_10G, TXP_MR_10E, TXP_MR_10E_C, or TXP_MR_10E_L Line Settings	5-40
Table 5-21	TXP_MR_10G, TXP_MR_10E, TXP_MR_10E_C, or TXP_MR_10E_L Section Trace Settings	5-43
Table 5-22	TXP_MR_10G, TXP_MR_10E, TXP_MR_10E_C, and TXP_MR_10E_L Card Wavelength Trunk Settings	5-45
Table 5-23	TXP_MR_10G, TXP_MR_10E, TXP_MR_10E_C, or TXP_MR_10E_L Card Line Threshold Settings	5-46
Table 5-24	TXP_MR_10G, TXP_MR_10E, TXP_MR_10E_C, or TXP_MR_10E_L Card GE LAN Phy Variables	5-48
Table 5-25	10G Multirate Transponder Trunk Port TCA Thresholds	5-51
Table 5-26	10G Multirate Transponder Trunk Port Alarm Thresholds	5-52
Table 5-27	TXP_MR_10G, TXP_MR_10E, TXP_MR_10E_C, or TXP_MR_10E_L Card Client Interface TCA Thresholds	5-53
Table 5-28	TXP_MR_10G, TXP_MR_10E, TXP_MR_10E_C, or TXP_MR_10E_L Card Client Interface Alarm Thresholds	5-54
Table 5-29	TXP_MR_10G, TXP_MR_10E, TXP_MR_10E_C, or TXP_MR_10E_L Card OTN Lines Settings	5-55
Table 5-30	TXP_MR_10G, TXP_MR_10E, TXP_MR_10E_C, or TXP_MR_10E_L Card ITU-T G.709 Threshold Settings	5-56
Table 5-31	TXP_MR_10G, TXP_MR_10E, TXP_MR_10E_C, or TXP_MR_10E_L Card FEC Threshold Settings	5-57
Table 5-32	10G Multirate Transponder Trail Trace Identifier Settings	5-57
Table 5-33	MXP_2.5G_10G, MXP_2.5G_10E, MXP_2.5G_10E_C, or MXP_2.5G_10E_L Card Settings	5-60
Table 5-34	MXP_2.5G_10G, MXP_2.5G_10E, MXP_2.5G_10E_C, or MXP_2.5G_10E_L Card Line Settings	5-62
Table 5-35	MXP_2.5G_10G, MXP_2.5G_10E, MXP_2.5G_10E_C, or MXP_2.5G_10E_L Card Section Trace Settings	5-64
Table 5-36	MXP_2.5G_10E, MXP_2.5G_10E_C, or MXP_2.5G_10E_L Card Trunk Settings	5-66
Table 5-37	MXP_2.5G_10G, MXP_2.5G_10E, MXP_2.5G_10E_C, and MXP_2.5G_10E_L Card Wavelength Trunk Settings	5-68
Table 5-38	MXP_2.5G_10G, MXP_2.5G_10E, MXP_2.5G_10E_C, or MXP_2.5G_10E_L Card Line Threshold Settings	5-69
Table 5-39	MXP_2.5G_10G, MXP_2.5G_10E, MXP_2.5G_10E_C, or MXP_2.5G_10E_L Trunk Port TCA Thresholds	5-72
Table 5-40	MXP_2.5G_10G, MXP_2.5G_10E, MXP_2.5G_10E_C, or MXP_2.5G_10E_L Trunk Port Alarm Thresholds	5-72

Table 5-41	MXP_2.5G_10G, MXP_2.5G_10E, MXP_2.5G_10E_C, or MXP_2.5G_10E_L Card Client Interfaces TCA Thresholds	5-73
Table 5-42	MXP_2.5G_10G, MXP_2.5G_10E, MXP_2.5G_10E_C, or MXP_2.5G_10E_L Card Client Interfaces Alarm Thresholds	5-74
Table 5-43	MXP_2.5G_10G, MXP_2.5G_10E, MXP_2.5G_10E_C, or MXP_2.5G_10E_L Card Line OTN Settings	5-75
Table 5-44	MXP_2.5G_10G, MXP_2.5G_10E, MXP_2.5G_10E_C, or MXP_2.5G_10E_L ITU-T G.709 Threshold Settings	5-76
Table 5-45	MXP_2.5G_10G, MXP_2.5G_10E, MXP_2.5G_10E_C, or MXP_2.5G_10E_L FEC Threshold Settings	5-77
Table 5-46	MXP_2.5G_10G, MXP_2.5G_10E, MXP_2.5G_10E_C, or MXP_2.5G_10E_L Trail Trace Identifier Settings	5-78
Table 5-47	MXP_MR_2.5G or MXPP_MR_2.5G Card Client Settings	5-80
Table 5-48	MXP_MR_2.5G or MXPP_MR_2.5G Card Line Distance Extension Settings	5-84
Table 5-49	MXP_MR_2.5G or MXPP_MR_2.5G Card Line SONET or SDH Settings	5-86
Table 5-50	MXP_MR_2.5G or MXPP_MR_2.5G Card Line Section Trace Settings	5-88
Table 5-51	MXP_MR_2.5G or MXPP_MR_2.5G Card Wavelength Trunk Settings	5-89
Table 5-52	MXP_MR_2.5G or MXPP_MR_2.5G Card Line Threshold Settings	5-90
Table 5-53	MXP_MR_2.5G and MXPP_MR_2.5G Card 1G Ethernet or 1G FC/FICON Variables	5-92
Table 5-54	MXP_MR_2.5G and MXPP_MR_2.5G Card Client Interface TCA Thresholds	5-95
Table 5-55	MXP_MR_2.5G and MXPP_MR_2.5G Card Client Interface Alarm Thresholds	5-96
Table 5-56	MXP_MR_10DME_C or MXP_MR_10DME_L Card Line Client Settings	5-99
Table 5-57	MXP_MR_10DME_C or MXP_MR_10DME_L Card Line Distance Extension Settings	5-101
Table 5-58	MXP_MR_10DME_C or MXP_MR_10DME_L Card Wavelength Trunk Settings	5-102
Table 5-59	MXP_MR_10DME_C or MXP_MR_10DME_L Card Line SONET or SDH Settings	5-103
Table 5-60	MXP_MR_10DME_C or MXP_MR_10DME_L Card Line Section Trace Settings	5-105
Table 5-61	MXP_MR_10DME_C or MXP_MR_10DME_L Card Line Threshold Settings	5-106
Table 5-62	MXP_MR_10DME_C or MXP_MR_10DME_L Ethernet Variables	5-109
Table 5-63	MXP_MR_10DME_C or MXP_MR_10DME_L FC/FICON Variables	5-109
Table 5-64	MXP_MR_10DME_C or MXP_MR_10DME_L ISC and ISC3 Variables	5-110
Table 5-65	MXP_MR_10DME_C and MXP_MR_10DME_L Card Client Interfaces TCA Thresholds	5-113
Table 5-66	MXP_MR_10DME_C and MXP_MR_10DME_L Card Client Interface Alarm Thresholds	5-114
Table 5-67	MXP_MR_10DME_C and MXP_MR_10DME_L Card OTN Line Settings	5-115
Table 5-68	MXP_MR_10DME_C and MXP_MR_10DME_L Card ITU-T G.709 Threshold Settings	5-116
Table 5-69	MXP_MR_10DME_C and MXP_MR_10DME_L Card FEC Threshold Settings	5-116
Table 5-70	MXP_MR_10DME_C and MXP_MR_10DME_L Card Trail Trace Identifier Settings	5-116
Table 5-71	ALS Settings	5-118
Table 7-1	OCHCC Client Rates	7-5

Table 7-2	OCHNC Channels	7-12
Table 7-3	Circuit Protection Types	7-34
Table 7-4	Cisco ONS 15454 Circuit Status	7-34
Table 8-1	Alarm Column Descriptions	8-7
Table 8-2	Color Codes for Alarms and Condition Severities	8-8
Table 9-1	Channel OADM Optical Line Ports	9-17
Table 9-2	Channel OADM Optical Line Ports	9-18
Table 9-3	Band OADM Optical Line Ports	9-18
Table 9-4	Band OADM Optical Line Ports	9-19
Table 10-1	HTML Commands for the Legal Disclaimer	10-8
Table 10-2	Managing Domains	10-29
Table 10-3	Link Classes By Network Scope	10-34
Table 11-1	OSCM and OSC-CSM Card OC-3/STM-1 Settings	11-3
Table 11-2	OSCM and OSC-CSM Cards SONET Threshold Settings	11-5
Table 11-3	OSCM and OSC-CSM Cards SDH Threshold Settings	11-6
Table 11-4	OSCM and OSC-CSM Card Optical Line Parameter Settings	11-7
Table 11-5	OSCM and OSC-CSM Cards Optical Line Warning Thresholds Settings	11-9
Table 11-6	OSCM and OSC-CSM Cards Optical Line Alarm Thresholds Settings	11-10
Table 11-7	OSC-CSM and OSCM Maintenance Settings	11-12
Table 11-8	OPT-PRE, OPT-BST, OPT-BST-E, and OPT-BST-L Amplifier Optical Line Settings	11-14
Table 11-9	OPT-PRE, OPT-BST, OPT-BST-E, and OPT-BST-L Card Optical Line Warning Threshold Settings	11-16
Table 11-10	OPT-PRE, OPT-BST, OPT-BST-E, and OPT-BST-L Card Optical Line Alarm Thresholds Settings	11-17
Table 11-11	OPT-PRE, OPT-BST, OPT-BST-E, and OPT-BST-L Optical Amplifier Line Settings	11-19
Table 11-12	OPT-PRE, OPT-BST, OPT-BST-E, and OPT-BST-L Card Amplifier Line Warning Threshold Settings	11-21
Table 11-13	OPT-PRE, OPT-BST, OPT-BST-E, and OPT-BST-L Card Amplifier Line Alarm Thresholds Setting	11-22
Table 11-14	OPT-BST Maintenance Settings	11-24
Table 11-15	OPT-AMP-L Amplifier Optical Line Settings	11-27
Table 11-16	OPT-AMP-L Card Optical Line Warning Threshold Settings	11-28
Table 11-17	OPT-AMP-L Card Optical Line Alarm Thresholds Setting	11-29
Table 11-18	OPT-AMP-L Optical Amplifier Line Settings	11-30
Table 11-19	OPT-AMP-L Card Amplifier Line Warning Threshold Settings	11-33
Table 11-20	OPT-AMP-L Card Amplifier Line Alarm Thresholds Setting	11-33
Table 11-21	OPT-AMP-L Maintenance Settings	11-37
Table 11-22	Multiplexer and Demultiplexer Card Optical Line Settings	11-39
Table 11-23	Multiplexer and Demultiplexer Card Optical Line Warning Threshold Settings	11-41

<i>Table 11-24</i>	Multiplexer and Demultiplexer Optical Line Alarm Threshold Settings	11-42
<i>Table 11-25</i>	Multiplexer and Demultiplexer Card Optical Channel Settings	11-43
<i>Table 11-26</i>	Multiplexer and Demultiplexer Card Optical Channel Warning Threshold Settings	11-46
<i>Table 11-27</i>	Multiplexer and Demultiplexer Card Optical Channel Alarm Threshold Settings	11-47
<i>Table 11-28</i>	32WSS and 32WSS-L Optical Channel Parameter Settings	11-50
<i>Table 11-29</i>	32WSS and 32WSS-L Optical Channel Warning Threshold Settings	11-52
<i>Table 11-30</i>	32WSS and 32WSS-L Optical Channel Alarm Threshold Settings	11-53
<i>Table 11-31</i>	32WSS and 32WSS-L Optical Line Parameter Settings	11-55
<i>Table 11-32</i>	32WSS and 32WSS-L Optical Line Warning Threshold Settings	11-57
<i>Table 11-33</i>	32WSS and 32WSS-L Optical Line Alarm Threshold Settings	11-57
<i>Table 11-34</i>	MMU Optical Line Parameter Settings	11-59
<i>Table 11-35</i>	MMU Optical Line Warning Threshold Settings	11-61
<i>Table 11-36</i>	MMU Optical Line Alarm Threshold Settings	11-62
<i>Table 13-1</i>	Audit Trail Column Definitions	13-15
<i>Table 13-2</i>	ONS 15454 Timing Report	13-20
<i>Table 13-3</i>	Incompatibility Alarms for ONS 15454 ANSI	13-30
<i>Table 13-4</i>	Incompatibility Alarms for ONS 15454 ETSI	13-31
<i>Table A-1</i>	Change CTC Views	A-2
<i>Table A-2</i>	Description of Node Icons on Network View Map	A-4
<i>Table A-3</i>	CTC Menu and Toolbar Options	A-6
<i>Table A-4</i>	CTC Window Mouse Shortcuts	A-10
<i>Table A-5</i>	Multishelf View Card-Related Shortcuts	A-11
<i>Table A-6</i>	Node/Shelf View Card-Related Shortcuts	A-12
<i>Table A-7</i>	Network Management Tasks in Network View	A-12
<i>Table A-8</i>	Table Display Options	A-13



NTP-G1 Unpack and Inspect the Shelf Assembly	1-6
NTP-G2 Install the Shelf Assembly	1-8
NTP-G3 Open and Remove the Front Door	1-20
NTP-G4 Open and Remove the FMEC Cover (ETSI Only)	1-23
NTP-G5 Remove the Backplane Covers (ANSI Only)	1-26
NTP-G6 Install the MIC-A/P and MIC-T/C/P FMECs (ETSI Only)	1-28
NTP-G7 Install the Power and Ground	1-30
NTP-G8 Install the Fan-Tray Assembly	1-40
NTP-G9 Install the Alarm Expansion Panel (ANSI Only)	1-43
NTP-G10 Attach Wires to Alarm, Timing, LAN, and Craft Pin Connections	1-46
NTP-G11 Install an External Wire-Wrap Panel on the AEP (ANSI Only)	1-57
NTP-G12 Install and Close the FMEC Cover (ETSI Only)	1-61
NTP-G13 Install the Rear Cover (ANSI Only)	1-62
NTP-G14 Install DWDM Equipment	1-64
NTP-G15 Install the Common Control Cards	1-72
NTP-G145 Connect a Multishelf Node and Subtending Shelves to an MS-ISC-100T Card	1-78
NTP-G158 Connect a Multishelf Node and Subtending Shelves to a Cisco Catalyst 2950	1-80
NTP-G159 Configure a Cisco Catalyst 2950 for a Multishelf Node	1-80
NTP-G16 Perform the Shelf Installation Acceptance Test	1-82
NTP-G17 Set Up Computer for CTC	2-1
NTP-G18 Set Up CTC Computer for Local Craft Connection to the ONS 15454	2-9
NTP-G19 Set Up a CTC Computer for a Corporate LAN Connection to the ONS 15454	2-21
NTP-G21 Log into the ONS 15454 GUI	2-23
NTP-G139 Verify Cisco MetroPlanner Reports and Files	3-3
NTP-G22 Verify Common Card Installation	3-4
NTP-G144 Provision a Multishelf Node	3-5
NTP-G23 Create Users and Assign Security	3-7
NTP-G24 Set Up Name, Date, Time, and Contact Information	3-10
NTP-G25 Set Battery Power Monitor Thresholds	3-12
NTP-G26 Set Up CTC Network Access	3-13
NTP-G27 Set Up the ONS 15454 for Firewall Access	3-24

NTP-G132 Provision OSI	3-27
NTP-G28 Set Up SNMP	3-36
NTP-G143 Import the Cisco MetroPlanner NE Update Configuration File	3-38
NTP-G30 Install the DWDM Cards	3-44
NTP-G31 Install the DWDM Dispersion Compensating Units	3-49
NTP-G32 Install the Transponder and Muxponder Cards	3-50
NTP-G123 Install the Filler Cards	3-55
NTP-G34 Install Fiber-Optic Cables on DWDM Cards and DCUs	3-56
NTP-G140 Install Fiber-Optic Cables Between Terminal, Hub, or ROADM Node DWDM Cards and TXP/MXP Cards	3-62
NTP-G191 Install Fiber-Optic Cables on Passthrough ROADM Nodes	3-73
NTP-G141 Install Fiber-Optic Cables for Y-Cable Protection Modules	3-75
NTP-G152 Create and Verify Internal Patchcords	3-80
NTP-G37 Run Automatic Node Setup	3-82
NTP-G38 Provision OSC Terminations	3-83
NTP-G39 Verify OSCM Transmit Power	3-85
NTP-G163 Upgrade Nodes in Single-Shelf Mode to Multishelf Mode	3-87
NTP-G41 Perform the Terminal or Hub Node with 32MUX-O and 32DMX-O Cards Acceptance Test	4-2
NTP-G42 Perform the Terminal Node with 32WSS and 32DMX Cards Acceptance Test	4-8
NTP-G153 Perform the Terminal Node with 32WSS-L and 32DMX-L Cards Acceptance Test	4-13
NTP-G43 Perform the ROADM Node with 32WSS and 32DMX Cards Acceptance Test	4-20
NTP-G154 Perform the ROADM Node with 32WSS-L and 32DMX-L Cards Acceptance Test	4-42
NTP-G44 Perform the Anti-ASE Hub Node Acceptance Test	4-64
NTP-G45 Perform the C-Band Line Amplifier Node with OSCM Cards Acceptance Test	4-66
NTP-G155 Perform the L-Band Line Amplifier Node with OSCM Cards Acceptance Test	4-70
NTP-G46 Perform the C-Band Line Amplifier Node with OSC-CSM Cards Acceptance Test	4-74
NTP-G156 Perform the L-Band Line Amplifier Node with OSC-CSM Cards Acceptance Test	4-78
NTP-G47 Perform the C-Band Line Amplifier Node with OSCM and OSC-CSM Cards Acceptance Test	4-82
NTP-G157 Perform the L-Band Line Amplifier Node with OSCM and OSC-CSM Cards Acceptance Test	4-86
NTP-G48 Perform the OADM Node Acceptance Test on a Symmetric Node with OSCM Cards	4-90
NTP-G49 Perform the OADM Active Node Acceptance Test on a Symmetric Node with OSC-CSM Cards	4-102
NTP-G50 Perform the OADM Passive Node Acceptance Test on a Symmetric Node with OSC-CSM Cards	4-108
NTP-G128 Manage Pluggable Port Modules	5-2
NTP-G33 Create a Y-Cable Protection Group	5-14
NTP-G98 Provision the 2.5G Multirate Transponder Card Line Settings and PM Parameter Thresholds	5-17

NTP-G96 Provision the 10G Multirate Transponder Card Line Settings, PM Parameters, and Thresholds	5-37
NTP-G97 Modify the 4x2.5G Muxponder Card Line Settings and PM Parameter Thresholds	5-58
NTP-G99 Modify the 2.5G Data Muxponder Card Line Settings and PM Parameter Thresholds	5-79
NTP-G148 Modify the 10G Data Muxponder Card Line Settings and PM Parameter Thresholds	5-97
NTP-G162 Change the TXP or MXP ALS Maintenance Settings	5-117
NTP-G51 Verify DWDM Node Turn-Up	6-2
NTP-G52 Verify Node-to-Node Connections	6-3
NTP-G53 Set Up Timing	6-4
NTP-G54 Provision and Verify a DWDM Network	6-10
NTP-G56 Verify the OSNR	6-14
NTP-G142 Perform a Protection Switch Test	6-15
NTP-G57 Create a Logical Network Map	6-18
NTP-G151 Create and Delete Optical Channel Client Connections	7-2
NTP-G59 Create and Delete Optical Channel Network Connections	7-10
NTP-G150 Upgrade Optical Channel Network Connections to Optical Channel Client Connections	7-15
NTP-G60 Create and Delete Overhead Circuits	7-21
NTP-G62 Create a JO Section Trace	7-29
NTP-G58 Locate and View Optical Channel Network and Client Connections	7-30
NTP-G63 Document Existing Provisioning	8-2
NTP-G64 View Alarms, History, Events, and Conditions	8-6
NTP-G65 Delete Cleared Alarms from Display	8-14
NTP-G66 View Alarm-Affected Circuits	8-15
NTP-G67 View Alarm Counts on the LCD for a Node, Slot, or Port	8-15
NTP-G68 Create, Download, and Assign Alarm Severity Profiles	8-17
NTP-G69 Enable, Modify, or Disable Alarm Severity Filtering	8-25
NTP-G70 Suppress Alarms or Discontinue Alarm Suppression	8-29
NTP-G72 Provision External Alarms and Controls on the Alarm Interface Controller-International Card	8-32
NTP-G73 Change the PM Display	9-2
NTP-G74 Monitor DWDM Card Performance	9-9
NTP-G75 Monitor Transponder and Muxponder Performance	9-19
NTP-G76 Verify Optical Span Loss Using CTC	10-2
NTP-G77 Manage Automatic Power Control	10-3
NTP-G78 View ROADM Node Power Equalization	10-5
NTP-G80 Change Node Management Information	10-6
NTP-G134 Modify OSI Provisioning	10-9

NTP-G81 Change CTC Network Access	10-18
NTP-G82 Customize the CTC Network View	10-26
NTP-G83 Modify or Delete Card Protection Settings	10-34
NTP-G84 Initiate and Clear Y-Cable and Splitter External Switching Commands	10-37
NTP-G85 Modify or Delete OSC Terminations, DCC/GCC Terminations, and Provisionable Patchcords	10-42
NTP-G86 Convert a Pass-Through Connection to Add/Drop Connections	10-45
NTP-G87 Change Node Timing Parameters	10-47
NTP-G88 Modify Users and Change Security	10-48
NTP-G131 Convert DWDM Nodes to Hybrid Nodes	10-61
NTP-G89 Change SNMP Settings	10-64
NTP-G90 Modify OSCM and OSC-CSM Card Line Settings and PM Thresholds	11-2
NTP-G91 Modify OPT-PRE and OPT-BST Card Line Settings and PM Thresholds	11-13
NTP-G160 Modify OPT-AMP-L Card Line Settings and PM Thresholds	11-25
NTP-G92 Modify 32MUX-O, 32DMX-O, 32DMX, 32DMX-L, and 4MD Line Card Settings and PM Thresholds	11-38
NTP-G93 Modify the 32WSS and 32WSS-L Line Settings and PM Thresholds	11-48
NTP-G149 Modify the MMU Line Settings and PM Thresholds	11-58
NTP-G101 Modify Alarm Interface Controller–International Settings	11-62
NTP-G102 Change Card Service State	11-65
NTP-G107 Permanently Remove or Remove and Replace DWDM Cards	12-2
NTP-G127 Add an AD-xC-xx.x Card to an OADM Node	12-5
NTP-G129 Add a DWDM Node	12-8
NTP-G130 Remove a DWDM Node	12-10
NTP-G146 Add a Rack and/or Shelf to a Multishelf Node	12-13
NTP-G147 Delete a Shelf and/or Rack from a Multishelf Node	12-14
NTP-G103 Back Up the Database	13-2
NTP-G104 Restore the Database	13-3
NTP-G105 Restore the Node to Factory Configuration	13-4
NTP-G133 View and Manage OSI Information	13-9
NTP-G106 Reset Cards Using CTC	13-12
NTP-G108 Viewing the Audit Trail Records	13-14
NTP-G109 Off-Load the Audit Trail Record	13-16
NTP-G110 Off-Load the Diagnostics File	13-17
NTP-G112 Change the Node Timing Reference	13-17
NTP-G113 View the ONS 15454 Timing Report	13-19
NTP-G114 Inspect, Clean, and Replace the Air Filter	13-22

NTP-G115 Clean Fiber Connectors	13-25
NTP-G40 Replace the Front Door	13-28
NTP-G116 Replace the Fan-Tray Assembly	13-30
NTP-G117 Replace the ANSI Shelf Alarm Interface Panel	13-35
NTP-G118 Replace the ANSI Shelf Plastic Lower Backplane Cover	13-39
NTP-G135 Edit Network Element Defaults	13-41
NTP-G136 Import Network Element Defaults	13-42
NTP-G137 Export Network Element Defaults	13-43
NTP-G119 Power Down the Node	14-1



- DLP-G1 Unpack and Verify the Shelf Assembly **1-7**
- DLP-G2 Inspect the Shelf Assembly **1-7**
- DLP-G3 Reverse the Mounting Bracket to Fit a 19-inch (482.6-mm) Rack (ANSI Only) **1-10**
- DLP-G4 Install the External Brackets and Air Filter (ANSI Only) **1-11**
- DLP-G5 Mount the Shelf Assembly in a Rack (One Person) **1-13**
- DLP-G6 Mount the Shelf Assembly in a Rack (Two People) **1-15**
- DLP-G7 Mount Multiple Shelf Assemblies in a Rack **1-16**
- DLP-G8 Install the Air Ramp **1-19**
- DLP-G9 Open the Front Cabinet Compartment (Door) **1-20**
- DLP-G10 Remove the Front Door **1-21**
- DLP-G11 Open the FMEC Cover **1-24**
- DLP-G12 Remove the FMEC Cover **1-25**
- DLP-G13 Remove the Lower Backplane Cover **1-27**
- DLP-G14 Remove the Backplane Sheet Metal Cover **1-27**
- DLP-G15 Connect the Office Ground to the ONS 15454 ETSI **1-32**
- DLP-G16 Connect the Office Ground to the ONS 15454 ANSI **1-33**
- DLP-G17 Connect Office Power to the ONS 15454 ETSI **1-35**
- DLP-G18 Connect Office Power to the ONS 15454 ANSI **1-36**
- DLP-G19 Turn On and Verify Office Power **1-39**
- DLP-G20 Install Alarm Wires on the MIC-A/P (ETSI Only) **1-47**
- DLP-G21 Install Timing Wires on the MIC-C/T/P (ETSI Only) **1-50**
- DLP-G22 Install LAN Wires on the MIC-C/T/P (ETSI Only) **1-51**
- DLP-G23 Install Alarm Wires on the Backplane (ANSI Only) **1-52**
- DLP-G24 Install Timing Wires on the Backplane (ANSI Only) **1-54**
- DLP-G25 Install LAN Wires on the Backplane (ANSI Only) **1-55**
- DLP-G26 Install the TL1 Craft Interface Wires (ANSI Only) **1-56**
- DLP-G27 Install the DCU Shelf Assembly **1-65**
- DLP-G28 Install the Fiber Patch-Panel Tray **1-66**
- DLP-G29 Install the Fiber-Storage Tray **1-66**
- DLP-G371 Install the Ethernet Adapter Panel **1-67**
- DLP-G351 Install the Y-Cable Module Tray **1-67**

- DLP-G30 Install the FlexLayer Shelf **1-68**
- DLP-G31 Install the FlexLayer Modules **1-69**
- DLP-G32 Install the Y-Cable Protection Modules in the FlexLayer Shelf **1-70**
- DLP-G377 Install the Y-Cable Protection Modules in the Y-Cable Module Tray **1-71**
- DLP-G33 Install the TCC2 or TCC2P Card **1-73**
- DLP-G34 Install the AIC-I Card **1-76**
- DLP-G309 Install the MS-ISC-100T Card **1-77**
- DLP-G35 Inspect the Shelf Installation and Connections **1-84**
- DLP-G36 Measure Voltage **1-84**
- DLP-G37 Run the CTC Installation Wizard for Windows PCs **2-2**
- DLP-G38 Run the CTC Installation Wizard for Solaris Workstations **2-5**
- DLP-G52 Change the JRE Version **2-8**
- DLP-G39 Set Up a Windows PC for Craft Connection to an ONS 15454 on the Same Subnet Using Static IP Addresses **2-11**
- DLP-G40 Set Up a Windows PC for Craft Connection to an ONS 15454 Using Dynamic Host Configuration Protocol **2-13**
- DLP-G41 Set Up a Windows PC for Craft Connection to an ONS 15454 Using Automatic Host Detection **2-16**
- DLP-G42 Set Up a Solaris Workstation for a Craft Connection to an ONS 15454 **2-19**
- DLP-G43 Disable or Bypass Proxy Service Using Internet Explorer (Windows) **2-22**
- DLP-G44 Disable or Bypass Proxy Service Using Netscape (Windows) or Mozilla (Solaris) **2-22**
- DLP-G331 Adjust the Java Virtual Memory Heap Size (Windows) **2-24**
- DLP-G46 Log into CTC **2-25**
- DLP-G47 Install Public-Key Security Certificate **2-28**
- DLP-G48 Create Login Node Groups **2-29**
- DLP-G49 Add a Node to the Current Session or Login Group **2-30**
- DLP-G50 Delete a Node from the Current Session or Login Group **2-31**
- DLP-G51 Delete a Node from a Specific Login Node Group **2-31**
- DLP-G53 Configure the CTC Alerts Dialog Box for Automatic Popup **2-32**
- DLP-G54 Create a New User on a Single Node **3-8**
- DLP-G55 Create a New User on Multiple Nodes **3-9**
- DLP-G56 Provision IP Settings **3-14**
- DLP-G57 Set the IP Address, Default Router, and Network Mask Using the LCD **3-16**
- DLP-G264 Enable Node Security Mode **3-18**
- DLP-G58 Create a Static Route **3-20**
- DLP-G59 Set Up or Change Open Shortest Path First Protocol **3-21**
- DLP-G60 Set Up or Change Routing Information Protocol **3-23**

- DLP-G61 Provision the IIOP Listener Port on the ONS 15454 3-25
- DLP-G62 Provision the IIOP Listener Port on the CTC Computer 3-26
- DLP-G283 Provision OSI Routing Mode 3-28
- DLP-G284 Provision the TARP Operating Parameters 3-29
- DLP-G285 Add a Static TID to NSAP Entry to the TARP Data Cache 3-31
- DLP-G287 Add a TARP Manual Adjacency Table Entry 3-32
- DLP-G288 Provision OSI Routers 3-32
- DLP-G289 Provision Additional Manual Area Addresses 3-33
- DLP-G290 Enable the OSI Subnet on the LAN Interface 3-34
- DLP-G291 Create an IP-Over-CLNS Tunnel 3-35
- DLP-G351 Delete a Card in CTC 3-41
- DLP-G353 Preprovision a Single Slot 3-42
- DLP-G348 Use the Cisco MetroPlanner Shelf Layout Report 3-47
- DLP-G63 Install an SFP or XFP 3-52
- DLP-G273 Preprovision an SFP or XFP Slot 3-53
- DLP-G64 Remove an SFP or XFP 3-54
- DLP-G349 Use the Cisco MetroPlanner Internal Connections Report 3-58
- DLP-G315 Install Fiber-Optic Cables From the 32WSS/32DMX and 32MUX-O/32DMX-O Cards to the Standard Patch-Panel Tray 3-64
- DLP-G316 Install Fiber-Optic Cables from TXP/MXP Cards to the Standard Patch-Panel Tray 3-68
- DLP-G356 Install Fiber-Optic Cables from the 32WSS/32DMX and 32MUX-O/32DMX-O Cards to the Deep Patch-Panel Tray 3-69
- DLP-G357 Install Fiber-Optic Cables from the TXP/MXP Cards to the Deep Patch-Panel Tray 3-72
- DLP-G375 Install Fiber-Optic Cables on the Y-Cable Modules in the FlexLayer Shelf 3-76
- DLP-G376 Install Fiber-Optic Cables on the Y-Cable Modules in the Y-Cable Module Tray 3-77
- DLP-G354 Create an Internal Patchcord Manually 3-81
- DLP-G355 Delete an Internal Patchcord 3-82
- DLP-G314 Verify OSCM Transmit Power 3-86
- DLP-G268 Provision TXP_MR_10E_C Cards for Acceptance Testing 4-4
- DLP-G79 Verify the OPT-BST, OPT-BST-E, or OPT-BST-L Amplifier Laser and Power 4-5
- DLP-G80 Verify the OPT-PRE Amplifier Laser and Power 4-6
- DLP-G78 Verify the 32MUX-O Card Power 4-7
- DLP-G269 Verify the 32DMX-O Card Power 4-7
- DLP-G270 Verify the 32DMX Power 4-12
- DLP-G358 Provision TXP_MR_10E_L Card for Acceptance Testing 4-16
- DLP-G359 Verify the OPT-BST-L or OPT-AMP-L (OPT-Line Mode) Amplifier Laser and Power 4-17

DLP-G360 Verify the OPT-AMP-L (OPT-PRE Mode) Amplifier Laser and Power	4-18
DLP-G361 Verify the 32DMX-L Power	4-19
DLP-G310 Verify ROADM Node C-Band Pass-Through Channels	4-24
DLP-G311 Verify the East ROADM C-Band Add/Drop Channels	4-32
DLP-G312 Verify the West ROADM C-Band Add/Drop Channels	4-37
DLP-G362 Verify ROADM Node L-Band Pass-Through Channels	4-46
DLP-G363 Verify the East ROADM L-Band Add/Drop Channels	4-54
DLP-G364 Verify the West ROADM L-Band Add/Drop Channels	4-59
DLP-G85 Verify Express Channel Connections on an OADM Node with OSCM Cards	4-92
DLP-G87 Verify the AD-xB-xx.x Output Express Power	4-93
DLP-G88 Verify the AD-xC-xx.x Output Express Power	4-93
DLP-G271 Verify the AD-xC-xx.x Output Common Power	4-94
DLP-G272 Verify the AD-xB-xx.x Output Common Power	4-94
DLP-G89 Verify OADM Node Pass-Through Channel Connections	4-94
DLP-G90 Verify an AD-xB-xx.x Pass-Through Connection Power	4-96
DLP-G91 Verify an AD-xC-xx.x Pass-Through Connection	4-96
DLP-G84 Verify the OSC-CSM Incoming Power	4-97
DLP-G93 Verify Add and Drop Connections on an OADM Node with OSCM Cards	4-98
DLP-G92 Verify 4MD-xx.x Pass-Through Connection Power	4-100
DLP-G86 Verify Express Channel Connections on an OADM Node with OSC-CSM Cards	4-104
DLP-G83 Verify the OSC-CSM Power on OADM Nodes	4-105
DLP-G94 Verify Add and Drop Connections on an OADM Node with OSC-CSM Cards	4-105
DLP-G82 Verify the OSC-CSM Power	4-110
DLP-G235 Change the 2.5G Data Muxponder Card Mode	5-3
DLP-G332 Change the 10G Data Muxponder Port Mode	5-4
DLP-G277 Provision a Multirate PPM	5-6
DLP-G274 Verify Topologies for ETR_CLO and ISC Services	5-7
DLP-G278 Provision the Optical Line Rate	5-9
DLP-G280 Delete a PPM	5-12
DLP-G229 Change the 2.5G Multirate Transponder Card Settings	5-18
DLP-G230 Change the 2.5G Multirate Transponder Line Settings	5-19
DLP-G231 Change the 2.5G Multirate Transponder Line Section Trace Settings	5-22
DLP-G367 Change the 2.5G Multirate Transponder Trunk Wavelength Settings	5-23
DLP-G232 Change the 2.5G Multirate Transponder SONET or SDH Line Threshold Settings	5-24
DLP-G320 Change the 2.5G Multirate Transponder Line RMON Thresholds for 1G Ethernet or 1G FC/FICON Payloads	5-27

DLP-G305 Provision the 2.5G Multirate Transponder Trunk Port Alarm and TCA Thresholds	5-28
DLP-G306 Provision the 2.5G Multirate Transponder Client Port Alarm and TCA Thresholds	5-30
DLP-G234 Change the 2.5G Multirate Transponder OTN Settings	5-34
DLP-G365 Provision the TXP_MR_10G Data Rate	5-38
DLP-G216 Change the 10G Multirate Transponder Card Settings	5-38
DLP-G217 Change the 10G Multirate Transponder Line Settings	5-40
DLP-G218 Change the 10G Multirate Transponder Line Section Trace Settings	5-43
DLP-G368 Change the 10G Multirate Transponder Trunk Wavelength Settings	5-44
DLP-G219 Change the 10G Multirate Transponder Line Thresholds for SONET or SDH Payloads Including 10G Ethernet WAN Phy	5-45
DLP-G319 Change the 10G Multirate Transponder Line RMON Thresholds for 10G Ethernet LAN Phy Payloads	5-48
DLP-G301 Provision the 10G Multirate Transponder Trunk Port Alarm and TCA Thresholds	5-51
DLP-G302 Provision the 10G Multirate Transponder Client Port Alarm and TCA Thresholds	5-52
DLP-G221 Change the 10G Multirate Transponder OTN Settings	5-54
DLP-G222 Change the 4x2.5G Muxponder Card Settings	5-59
DLP-G223 Change the 4x2.5G Muxponder Line Settings	5-61
DLP-G224 Change the 4x2.5G Muxponder Section Trace Settings	5-64
DLP-G225 Change the 4x2.5G Muxponder Trunk Settings	5-65
DLP-G369 Change the 4x2.5G Muxponder Trunk Wavelength Settings	5-67
DLP-G226 Change the 4x2.5G Muxponder SONET/SDH Line Thresholds Settings	5-68
DLP-G303 Provision the 4x2.5G Muxponder Trunk Port Alarm and TCA Thresholds	5-71
DLP-G304 Provision the 4x2.5G Muxponder Client Port Alarm and TCA Thresholds	5-73
DLP-G228 Change the 4x2.5G Muxponder Line OTN Settings	5-75
DLP-G236 Change the 2.5G Data Muxponder Client Line Settings	5-80
DLP-G237 Change the 2.5G Data Muxponder Distance Extension Settings	5-83
DLP-G238 Change the 2.5G Data Muxponder SONET (OC-48)/SDH (STM-16) Settings	5-85
DLP-G239 Change the 2.5G Data Muxponder Section Trace Settings	5-87
DLP-G370 Change the 2.5G Data Muxponder Trunk Wavelength Settings	5-89
DLP-G240 Change the 2.5G Data Muxponder SONET or SDH Line Thresholds	5-90
DLP-G321 Change the 2.5G Data Muxponder Line Thresholds for 1G Ethernet or 1G FC/FICON Payloads	5-92
DLP-G307 Provision the 2.5G Data Muxponder Trunk Port Alarm and TCA Thresholds	5-94
DLP-G308 Provision the 2.5G Data Muxponder Client Port Alarm and TCA Thresholds	5-95
DLP-G333 Change the 10G Data Muxponder Client Line Settings	5-99
DLP-G334 Change the 10G Data Muxponder Distance Extension Settings	5-101
DLP-G340 Change the 10G Data Muxponder Trunk Wavelength Settings	5-102

- DLP-G335 Change the 10G Data Muxponder SONET (OC-192)/SDH (STM-64) Settings 5-103
- DLP-G336 Change the 10G Data Muxponder Section Trace Settings 5-105
- DLP-G341 Change the 10G Data Muxponder SONET or SDH Line Thresholds 5-106
- DLP-G337 Change the 10G Data Muxponder Line RMON Thresholds for Ethernet, 1G FC/FICON, or ISC/ISC3 Payloads 5-108
- DLP-G338 Provision the 10G Data Muxponder Trunk Port Alarm and TCA Thresholds 5-111
- DLP-G339 Provision the 10G Data Muxponder Client Port Alarm and TCA Thresholds 5-112
- DLP-G366 Change the 10G Data Muxponder OTN Settings 5-115
- DLP-G95 Set Up External or Line Timing 6-4
- DLP-G96 Set Up Internal Timing 6-7
- DLP-G350 Use the Cisco MetroPlanner Traffic Matrix Report 6-8
- DLP-G104 Assign a Name to a Port 7-3
- DLP-G345 Verify OCHCC Client Ports 7-3
- DLP-G346 Provision Optical Channel Client Connections 7-4
- DLP-G347 Delete Optical Channel Client Connections 7-8
- DLP-G424 Edit an OCHCC Circuit Name 7-9
- DLP-G425 Edit an OCH Trail Circuit Name 7-10
- DLP-G105 Provision Optical Channel Network Connections 7-11
- DLP-G106 Delete Optical Channel Network Connections 7-13
- DLP-G426 Edit an OCHNC Circuit Name 7-15
- DLP-G344 Verify Provisionable Patchcords 7-18
- DLP-G99 Create a Provisionable Patchcord 7-20
- DLP-G76 Provision DCC/GCC Terminations 7-22
- DLP-G97 Provision a Proxy Tunnel 7-24
- DLP-G98 Provision a Firewall Tunnel 7-25
- DLP-G108 Change the Service State for a Port 7-25
- DLP-G109 Provision Orderwire 7-26
- DLP-G110 Create a User Data Channel Circuit 7-28
- DLP-G112 Delete Overhead Circuits 7-29
- DLP-G100 Search for Optical Channel Network and Client Connections 7-31
- DLP-G101 View Optical Channel Network and Client Connection Information 7-32
- DLP-G102 Filter the Display of Optical Channel Network and Client Connections 7-35
- DLP-G103 View Optical Channel Network Connections on a Span 7-37
- DLP-G113 Print CTC Data 8-2
- DLP-G114 Export CTC Data 8-4
- DLP-G115 View Alarms 8-7

- DLP-G116 View Alarm or Event History **8-8**
- DLP-G117 Change the Maximum Number of Session Entries for Alarm History **8-10**
- DLP-G118 Display Alarms and Conditions Using Time Zone **8-11**
- DLP-G119 Synchronize Alarms **8-12**
- DLP-G120 View Conditions **8-12**
- DLP-G121 Create a New or Cloned Alarm Severity Profile **8-17**
- DLP-G122 Download an Alarm Severity Profile **8-20**
- DLP-G123 Apply Alarm Profiles to Ports **8-21**
- DLP-G124 Apply Alarm Profiles to Cards and Nodes **8-23**
- DLP-G125 Delete Alarm Severity Profiles **8-23**
- DLP-G126 Enable Alarm Filtering **8-26**
- DLP-G127 Modify Alarm, Condition, and History Filtering Parameters **8-26**
- DLP-G128 Disable Alarm Filtering **8-28**
- DLP-G129 Suppress Alarm Reporting **8-29**
- DLP-G130 Discontinue Alarm Suppression **8-31**
- DLP-G131 Refresh PM Counts at 15-Minute Intervals **9-2**
- DLP-G132 Refresh PM Counts at One-Day Intervals **9-3**
- DLP-G133 View Near-End PM Counts **9-4**
- DLP-G134 View Far-End PM Counts **9-5**
- DLP-G135 Reset Current PM Counts **9-6**
- DLP-G136 Clear Selected PM Counts **9-7**
- DLP-G137 Set Auto-Refresh Interval for Displayed PM Counts **9-8**
- DLP-G138 Refresh PM Counts for a Different Port **9-9**
- DLP-G139 View Optical Service Channel PM Parameters **9-10**
- DLP-G140 View Optical Amplifier Power Statistics **9-12**
- DLP-G141 View Optical Power Statistics for 32MUX-O, 32WSS, 32WSS-L, 32DMX-O, 32DMX, and 32DMX-L Cards **9-13**
- DLP-G276 View 4-Channel Multiplexer/Demultiplexer Optical Power Statistics **9-15**
- DLP-G142 View Channel Optical Add/Drop Multiplexer Power Statistics **9-16**
- DLP-G143 View Band Optical Add/Drop Multiplexer Power Statistics **9-18**
- DLP-G144 Enable or Disable OTN ITU-T G.709 Performance Monitoring **9-20**
- DLP-G145 Enable or Disable OTN FEC Performance Monitoring **9-21**
- DLP-G146 View Optics PM Parameters **9-22**
- DLP-G147 View Payload PM Parameters **9-23**
- DLP-G148 View OTN PM Parameters **9-25**
- DLP-G149 View Payload Statistics PM Parameters **9-27**

DLP-G150 View Payload Utilization PM Parameters	9-29
DLP-G151 View Payload History PM Parameters	9-30
DLP-G152 View Payload SONET/SDH PM Parameters	9-32
DLP-G157 Disable Automatic Power Control	10-4
DLP-G158 Enable Automatic Power Control	10-4
DLP-G159 Refresh Automatic Power Control Information	10-5
DLP-G160 Change the Node Name, Date, Time, and Contact Information	10-7
DLP-G161 Change the Login Legal Disclaimer	10-8
DLP-G284 Modify the TARP Operating Parameters	10-10
DLP-G286 Remove a Static TID to NSAP Entry from the TARP Data Cache	10-12
DLP-G287 Add a TARP Manual Adjacency Table Entry	10-12
DLP-G292 Remove a TARP Manual Adjacency Table Entry	10-13
DLP-G293 Change the OSI Routing Mode	10-14
DLP-G294 Edit the OSI Router Configuration	10-15
DLP-G295 Edit the OSI Subnetwork Point of Attachment	10-16
DLP-G296 Edit an IP-Over-CLNS Tunnel	10-17
DLP-G297 Delete an IP-Over-CLNS Tunnel	10-18
DLP-G162 Change IP Settings	10-19
DLP-G265 Lock Node Security	10-20
DLP-G266 Modify Backplane Port IP Settings in Security Mode	10-21
DLP-G267 Disable Node Security Mode	10-22
DLP-G163 Modify a Static Route	10-23
DLP-G164 Delete a Static Route	10-24
DLP-G165 Disable OSPF	10-24
DLP-G166 Delete a Proxy Tunnel	10-25
DLP-G167 Delete a Firewall Tunnel	10-25
DLP-G168 Change the Network View Background Color	10-26
DLP-G169 Change the Default Network View Background Map	10-27
DLP-G170 Apply a Custom Network View Background Map	10-28
DLP-G171 Create Domain Icons	10-28
DLP-G172 Manage Domain Icons	10-29
DLP-G173 Enable Dialog Box Do-Not-Display Option	10-30
DLP-G174 Switch Between TDM and DWDM Network Views	10-31
DLP-G330 Consolidate Links in Network View	10-31
DLP-G175 Modify a Y-Cable Protection Group	10-35

DLP-G176 Modify a Splitter Protection Group	10-35
DLP-G177 Delete a Y-Cable Protection Group	10-36
DLP-G178 Apply a Manual Y-Cable or Splitter Protection Switch	10-38
DLP-G179 Apply a Force Y-Cable or Splitter Protection Switch	10-38
DLP-G180 Clear a Manual or Force Y-Cable or Splitter Protection Switch	10-39
DLP-G181 Apply a Lock-On	10-40
DLP-G182 Apply a Lockout	10-40
DLP-G183 Clear a Lock-On or Lockout	10-41
DLP-G184 Change a DCC/GCC Termination	10-43
DLP-G185 Delete a DCC/GCC Termination	10-43
DLP-G186 Delete an OSC Termination	10-44
DLP-G187 Delete a Provisionable Patchcord	10-45
DLP-G188 Change Security Policy for a Single Node	10-49
DLP-G189 Change Security Policy for Multiple Nodes	10-50
DLP-G317 Change Node Access and PM Clearing Privilege	10-52
DLP-G328 Grant Superuser Privileges to a Provisioning User	10-53
DLP-G191 Change User Password and Security Level on a Single Node	10-54
DLP-G192 Change User Password and Security Level for Multiple Nodes	10-55
DLP-G193 Delete a User From a Single Node	10-55
DLP-G194 Delete a User From Multiple Nodes	10-56
DLP-G195 Log Out a User on a Single Node	10-57
DLP-G196 Log Out a User on Multiple Nodes	10-58
DLP-G281 Configure the Node for RADIUS Authentication	10-58
DLP-G282 View and Terminate Active Logins	10-61
DLP-G197 Modify SNMP Trap Destinations	10-65
DLP-G198 Delete SNMP Trap Destinations	10-66
DLP-G199 Change the OSCM and OSC-CSM Optical Service Channel Settings	11-2
DLP-G200 Change the OSCM and OSC-CSM Optical Service Channel Thresholds	11-5
DLP-G201 Change Optical Line Parameters for OSCM and OSC-CSM Cards	11-6
DLP-G202 Change the OSCM and OSC-CSM Optical Line Threshold Settings	11-8
DLP-G203 Change the OSCM and OSC-CSM ALS Maintenance Settings	11-12
DLP-G204 Change Optical Line Settings for OPT-PRE and OPT-BST Amplifiers	11-14
DLP-G205 Change Optical Line Threshold Settings for OPT-PRE and OPT-BST Amplifiers	11-15
DLP-G206 Change Optical Amplifier Line Settings for OPT-PRE and OPT-BST Amplifiers	11-18
DLP-G207 Change Optical Amplifier Threshold Settings for OPT-PRE and OPT-BST Amplifiers	11-20

- DLP-G322 Change the OPT-BST ALS Maintenance Settings 11-24
- DLP-G323 Change Optical Line Settings for OPT-AMP-L Amplifiers 11-26
- DLP-G324 Change Optical Line Threshold Settings for OPT-AMP-L Amplifiers 11-28
- DLP-G325 Change Optical Amplifier Line Settings for OPT-AMP-L Amplifiers 11-30
- DLP-G326 Change Optical Amplifier Threshold Settings for OPT-AMP-L Amplifiers 11-32
- DLP-G327 Change the ALS Maintenance Settings of an OPT-AMP-L Card Configured in OPT-LINE Mode 11-36
- DLP-G208 Change Optical Line Settings for Multiplexer and Demultiplexer Cards 11-39
- DLP-G209 Change Optical Line Threshold Settings for Multiplexer and Demultiplexer Cards 11-41
- DLP-G210 Change Optical Channel Settings for Multiplexer and Demultiplexer Cards 11-43
- DLP-G211 Change Optical Channel Threshold Settings for Multiplexer and Demultiplexer Cards 11-45
- DLP-G212 Change 32WSS and 32WSS-L Optical Channel Parameters 11-49
- DLP-G213 Change the 32WSS and 32WSS-L Optical Channel Thresholds 11-52
- DLP-G214 Change 32WSS and 32WSS-L Optical Line Parameters 11-55
- DLP-G215 Change the 32WSS and 32-WSS-L Optical Line Thresholds 11-56
- DLP-G342 Change MMU Optical Line Parameters 11-59
- DLP-G343 Change the MMU Optical Line Thresholds 11-60
- DLP-G245 Change External Alarms Using the AIC-I Card 11-63
- DLP-G246 Change External Controls Using the AIC-I Card 11-64
- DLP-G247 Change AIC-I Card Orderwire Settings 11-64
- DLP-G254 Place OPT-BST, OPT-BST-E, OPT-BST-L, and OPT-PRE Ports Out of Service 12-4
- DLP-G318 Place OPT-BST, OPT-BST-E, OPT-BST-L, and OPT-PRE Ports In Service 12-5
- DLP-G248 Use the Reinitialization Tool to Clear the Database and Upload Software (Windows) 13-5
- DLP-G249 Use the Reinitialization Tool to Clear the Database and Upload Software (UNIX) 13-7
- DLP-G298 View IS-IS Routing Information Base 13-9
- DLP-G299 View ES-IS Routing Information Base 13-10
- DLP-G300 Manage the TARP Data Cache 13-11
- DLP-G250 Reset the TCC2/TCC2P Card 13-12
- DLP-G251 Reset DWDM Cards Using CTC 13-13
- DLP-G259 Manual or Force Switch the Node Timing Reference 13-18
- DLP-G260 Clear a Manual or Force Switch on a Node Timing Reference 13-19
- DLP-G261 Clean Multi Fiber-Optic Cable Connectors 13-26
- DLP-G262 Clean Fiber Connectors with CLETOP 13-27
- DLP-G263 Clean the Fiber Adapters 13-27



About this Guide



Note

The terms "Unidirectional Path Switched Ring" and "UPSR" may appear in Cisco literature. These terms do not refer to using Cisco ONS 15xxx products in a unidirectional path switched ring configuration. Rather, these terms, as well as "Path Protected Mesh Network" and "PPMN," refer generally to Cisco's path protection feature, which may be used in any topological network configuration. Cisco does not recommend using its path protection feature in any particular topological network configuration.

This section explains the objectives, intended audience, and organization of this publication and describes the conventions that convey instructions and other information.

This section provides the following information:

- [Revision History](#)
- [Document Objectives](#)
- [Audience](#)
- [Document Organization](#)
- [Related Documentation](#)
- [Document Conventions](#)
- [Obtaining Optical Networking Information](#)
- [Obtaining Documentation and Submitting a Service Request](#)

Revision History

Date	Notes
March 2007	<ul style="list-style-type: none"> • Revision History Table added for the first time • Corrected product part numbers for the UBIC-V and UBIC-H DS3 cables.
September 2007	<ul style="list-style-type: none"> • Updated About this Guide chapter. • Updated the NTP-G130 Remove a DWDM Node procedure in the “Add and Removed Cards and Nodes” chapter
March 2008	Updated the procedure to delete a Y-Cable Protection Group and added a note in the “DLP-G177 Delete a Y-Cable Protection Group” section in Chapter 10, “Manage the Node”.
July 2008	<p>Updated the fuse ratings in the following sections in Chapter 1, Install the Shelf and Common Control Cards:</p> <ul style="list-style-type: none"> • DLP-G5 Mount the Shelf Assembly in a Rack (One Person) • NTP-G7 Install the Power and Ground • DLP-G19 Turn On and Verify Office Power • DLP-G6 Mount the Shelf Assembly in a Rack (Two People) • DLP-G7 Mount Multiple Shelf Assemblies in a Rack
December 2008	Added a note in the “DLP G332 Change the 10G Data Muxponder Port Mode” section of Chapter 5 Provision Transponder and Muxponder Cards.
February 2009	Updated Step 7 of “NTP G143 Import the Cisco MetroPlanner NE Update Configuration File” in Chapter 3, Turn Up a Node.
May 2009	Updated “CTC Menu and Toolbar Options” section in Appendix A, CTC Information and Shortcuts.
October 2009	<p>Updated the “Clean Fiber Optic Connectors” procedure in Chapter 13, “Maintain the Node”.</p> <p>Added the “Clean Multi Fiber-Optic Cable Connectors” procedure in Chapter 13, “Maintain the Node”.</p>
November 2009	Added a note in “Delete a PPM” procedure in the chapter, “Provision Transponder and Muxponder Cards”.
June 2010	Updated the table with EAP cable length in NTP-G145 in the chapter, Install the Shelf and Common Control Cards.
July 2010	Deleted the section “DLP-G313 Verify OSC-CSM Transmit Power” in the chapter “Turn Up a Node”.
November 2010	Updated step 21 in “NTP-G42 Perform the Terminal Node with 32WSS and 32DMX Cards Acceptance Test”.
June 2011	Updated step 5 in the procedure “Remove Permanently or Remove and Replace DWDM Cards” of the chapter, “Upgrade, Add, and Remove Cards and Nodes”.

Date	Notes
December 2011	<ul style="list-style-type: none"> • Updated the procedure “DLP-G76 Provision DCC/GCC Terminations” in the chapter “Create Channels and Circuits”. • Updated the following procedures in the chapter “Manage the Node”: <ul style="list-style-type: none"> – NTP-G85 Modify or Delete OSC Terminations, DCC/GCC Terminations, and Provisionable Patchcords – DLP-G184 Change a DCC/GCC Termination – DLP-G185 Delete a DCC/GCC Termination
February 2012	Updated the procedure “DLP-G278 Provision the Optical Line Rate” in the chapter “Provision Transponder and Muxponder Cards”.
March 2012	Added a note in the procedure “NTP-G354 Create an Internal Patchcord Manually” in the chapter “Turn Up a Node”.
April 2012	Added a note in the procedure “DLP-G368 Change the 10G Multirate Transponder Trunk Wavelength Settings” in the chapter “Provision Transponder and Muxponder Cards”.
May 2012	Updated the “Set Up SNMP” procedure in the chapter “Turn Up a Node”.
June 2012	Document Part Number revisioned to 78-17206-02 and a full length book-PDF was generated.

Document Objectives

This document explains installation, turn up, provisioning, and maintenance for Cisco ONS 15454 dense wavelength division (DWDM) systems. Use this document in conjunction with the appropriate publications listed in the [Related Documentation](#) section.

Audience

To use this publication, you should be familiar with Cisco or equivalent optical transmission hardware and cabling, telecommunications hardware and cabling, electronic circuitry and wiring practices, and preferably have experience as a telecommunications technician.

Document Organization

The *Cisco ONS 15454 DWDM Procedure Guide* is organized into the following chapters:

- [Chapter 1, “Install the Shelf and Common Control Cards”](#) provides procedures for installing Cisco ONS 15454 ANSI and ETSI shelves and common control cards including the TCC2 and AIC/AIC-I.
- [Chapter 2, “Connect the PC and Log into the GUI”](#) includes procedures to install the Cisco Transport Controller (CTC), set up a computer for different connection types, and log into the Cisco ONS 15454.
- [Chapter 3, “Turn Up a Node”](#) provides procedures for node turn up and DWDM card installation.
- [Chapter 4, “Perform Node Acceptance Tests”](#) provides acceptance tests for each DWDM node type.

- [Chapter 5, “Provision Transponder and Muxponder Cards”](#) explains how to change transmission settings and provision pluggable port modules (PPMs) for transponder (TXP) and muxponder (MXP) cards.
- [Chapter 6, “Turn Up a Network”](#) explains how to turn up and test a DWDM network.
- [Chapter 7, “Create Channels and Circuits”](#) explains how to create DWDM optical channel network connections (OCHNCs) and overhead circuits.
- [Chapter 8, “Manage Alarms”](#) explains how to document existing node data, view and delete alarms, view alarm-affected circuits and LCD alarm counts, manage alarm profiles, filter alarms, suppress alarms, and provision external alarms.
- [Chapter 9, “Monitor Performance”](#) provides procedures to change the performance monitoring (PM) display, monitor performance, and manage remote monitoring (RMON) thresholds.
- [Chapter 10, “Manage the Node”](#) explains how to modify node provisioning for the Cisco ONS 15454 and perform common management tasks such as monitoring the DWDM automatic power control and span loss values.
- [Chapter 11, “Change DWDM Card Settings”](#) explains how to change line, performance monitoring (PM), and threshold settings on Cisco ONS 15454 cards.
- [Chapter 12, “Add and Remove Cards and Nodes”](#) explains how to add and remove DWDM cards and nodes.
- [Chapter 13, “Maintain the Node”](#) provides hardware and software maintenance procedures for the Cisco ONS 15454, including procedures for editing, importing, and exporting network element defaults.
- [Chapter 14, “Power Down a Node”](#) explains how to shut down an ONS 15454.

Related Documentation

Use the *Cisco ONS 15454 DWDM Procedure Guide* in conjunction with the following referenced publications:

- *Cisco ONS 15454 DWDM Reference Manual, Release 7.0*
- *Cisco ONS 15454 DWDM Troubleshooting Guide, Release 7.0*
- *Cisco ONS SONET TL1 Command Guide, Release 7.0*
- Cisco ONS SONET TL1 Reference Guide, Release 7.0
- Cisco ONS 15454 SDH TL1 Command Guide, Release 7.0
- Cisco ONS 15454 SDH TL1 Reference Guide, Release 7.0
- Release Notes for Cisco ONS 15454 Release 7.0
- Release Notes for Cisco ONS 15454 SDH Release 7.0
- Cisco Metroplanner DWDM Operations Guide, Release 7.0

For an update on End-of-Life and End-of-Sale notices, refer to http://www.cisco.com/en/US/products/hw/optical/ps2006/prod_eol_notices_list.html.

Document Conventions

This publication uses the following conventions:

Convention	Application
boldface	Commands and keywords in body text.
<i>italic</i>	Command input that is supplied by the user.
[]	Keywords or arguments that appear within square brackets are optional.
{ x x x }	A choice of keywords (represented by x) appears in braces separated by vertical bars. The user must select one.
Ctrl	The control key. For example, where Ctrl + D is written, hold down the Control key while pressing the D key.
screen font	Examples of information displayed on the screen.
boldface screen font	Examples of information that the user must enter.
< >	Command parameters that must be replaced by module-specific codes.



Note

Means *reader take note*. Notes contain helpful suggestions or references to material not covered in the document.



Caution

Means *reader be careful*. In this situation, the user might do something that could result in equipment damage or loss of data.



Warning

IMPORTANT SAFETY INSTRUCTIONS

This warning symbol means danger. You are in a situation that could cause bodily injury. Before you work on any equipment, be aware of the hazards involved with electrical circuitry and be familiar with standard practices for preventing accidents. Use the statement number provided at the end of each warning to locate its translation in the translated safety warnings that accompanied this device. Statement 1071

SAVE THESE INSTRUCTIONS

Waarschuwing

BELANGRIJKE VEILIGHEIDSINSTRUCTIES

Dit waarschuwingssymbool betekent gevaar. U verkeert in een situatie die lichamelijk letsel kan veroorzaken. Voordat u aan enige apparatuur gaat werken, dient u zich bewust te zijn van de bij elektrische schakelingen betrokken risico's en dient u op de hoogte te zijn van de standaard praktijken om ongelukken te voorkomen. Gebruik het nummer van de verklaring onderaan de waarschuwing als u een vertaling van de waarschuwing die bij het apparaat wordt geleverd, wilt raadplegen.

BEWAAR DEZE INSTRUCTIES

Varoitus

TÄRKEITÄ TURVALLISUUSOHJEITA

Tämä varoitusmerkki merkitsee vaaraa. Tilanne voi aiheuttaa ruumiillisia vammoja. Ennen kuin käsittelet laitteistoa, huomioi sähköpiirien käsittelemiseen liittyvät riskit ja tutustu onnettomuuksien yleisiin ehkäisytapoihin. Turvallisuusvaroitusten käännökset löytyvät laitteen mukana toimitettujen käännettyjen turvallisuusvaroitusten joukosta varoitusten lopussa näkyvien lausuntonumeroiden avulla.

SÄILYTÄ NÄMÄ OHJEET

Attention

IMPORTANTES INFORMATIONS DE SÉCURITÉ

Ce symbole d'avertissement indique un danger. Vous vous trouvez dans une situation pouvant entraîner des blessures ou des dommages corporels. Avant de travailler sur un équipement, soyez conscient des dangers liés aux circuits électriques et familiarisez-vous avec les procédures couramment utilisées pour éviter les accidents. Pour prendre connaissance des traductions des avertissements figurant dans les consignes de sécurité traduites qui accompagnent cet appareil, référez-vous au numéro de l'instruction situé à la fin de chaque avertissement.

CONSERVEZ CES INFORMATIONS

Warnung

WICHTIGE SICHERHEITSHINWEISE

Dieses Warnsymbol bedeutet Gefahr. Sie befinden sich in einer Situation, die zu Verletzungen führen kann. Machen Sie sich vor der Arbeit mit Geräten mit den Gefahren elektrischer Schaltungen und den üblichen Verfahren zur Vorbeugung vor Unfällen vertraut. Suchen Sie mit der am Ende jeder Warnung angegebenen Anweisungsnummer nach der jeweiligen Übersetzung in den übersetzten Sicherheitshinweisen, die zusammen mit diesem Gerät ausgeliefert wurden.

BEWAHREN SIE DIESE HINWEISE GUT AUF.

Avvertenza IMPORTANTI ISTRUZIONI SULLA SICUREZZA

Questo simbolo di avvertenza indica un pericolo. La situazione potrebbe causare infortuni alle persone. Prima di intervenire su qualsiasi apparecchiatura, occorre essere al corrente dei pericoli relativi ai circuiti elettrici e conoscere le procedure standard per la prevenzione di incidenti. Utilizzare il numero di istruzione presente alla fine di ciascuna avvertenza per individuare le traduzioni delle avvertenze riportate in questo documento.

CONSERVARE QUESTE ISTRUZIONI**Advarsel VIKTIGE SIKKERHETSINSTRUKSJONER**

Dette advarselssymbolet betyr fare. Du er i en situasjon som kan føre til skade på person. Før du begynner å arbeide med noe av utstyret, må du være oppmerksom på farene forbundet med elektriske kretser, og kjenne til standardprosedyrer for å forhindre ulykker. Bruk nummeret i slutten av hver advarsel for å finne oversettelsen i de oversatte sikkerhetsadvarslene som fulgte med denne enheten.

TA VARE PÅ DISSE INSTRUKSJONENE**Aviso INSTRUÇÕES IMPORTANTES DE SEGURANÇA**

Este símbolo de aviso significa perigo. Você está em uma situação que poderá ser causadora de lesões corporais. Antes de iniciar a utilização de qualquer equipamento, tenha conhecimento dos perigos envolvidos no manuseio de circuitos elétricos e familiarize-se com as práticas habituais de prevenção de acidentes. Utilize o número da instrução fornecido ao final de cada aviso para localizar sua tradução nos avisos de segurança traduzidos que acompanham este dispositivo.

GUARDE ESTAS INSTRUÇÕES**¡Advertencia! INSTRUCCIONES IMPORTANTES DE SEGURIDAD**

Este símbolo de aviso indica peligro. Existe riesgo para su integridad física. Antes de manipular cualquier equipo, considere los riesgos de la corriente eléctrica y familiarícese con los procedimientos estándar de prevención de accidentes. Al final de cada advertencia encontrará el número que le ayudará a encontrar el texto traducido en el apartado de traducciones que acompaña a este dispositivo.

GUARDE ESTAS INSTRUCCIONES**Varning! VIKTIGA SÄKERHETSANVISNINGAR**

Denna varningssignal signalerar fara. Du befinner dig i en situation som kan leda till personskada. Innan du utför arbete på någon utrustning måste du vara medveten om farorna med elkretsar och känna till vanliga förfaranden för att förebygga olyckor. Använd det nummer som finns i slutet av varje varning för att hitta dess översättning i de översatta säkerhetsvarningar som medföljer denna anordning.

SPARA DESSA ANVISNINGAR

FONTOS BIZTONSÁGI ELOÍRÁSOK

Ez a figyelmeztető jel veszélyre utal. Sérülésveszélyt rejtő helyzetben van. Mielott bármely berendezésen munkát végezte, legyen figyelemmel az elektromos áramkörök okozta kockázatokra, és ismerkedjen meg a szokásos balesetvédelmi eljárásokkal. A kiadványban szereplő figyelmeztetések fordítása a készülékhez mellékelte biztonsági figyelmeztetések között található; a fordítás az egyes figyelmeztetések végén látható szám alapján kereshető meg.

ORIZZE MEG EZEKET AZ UTASÍTÁSOKAT!

Предупреждение

ВАЖНЫЕ ИНСТРУКЦИИ ПО СОБЛЮДЕНИЮ ТЕХНИКИ БЕЗОПАСНОСТИ

Этот символ предупреждения обозначает опасность. То есть имеет место ситуация, в которой следует опасаться телесных повреждений. Перед эксплуатацией оборудования выясните, каким опасностям может подвергаться пользователь при использовании электрических цепей, и ознакомьтесь с правилами техники безопасности для предотвращения возможных несчастных случаев. Воспользуйтесь номером заявления, приведенным в конце каждого предупреждения, чтобы найти его переведенный вариант в переводе предупреждений по безопасности, прилагаемом к данному устройству.

СОХРАНИТЕ ЭТИ ИНСТРУКЦИИ

警告

重要的安全性说明

此警告符号代表危险。您正处于可能受到严重伤害的工作环境中。在您使用设备开始工作之前，必须充分意识到触电的危险，并熟练掌握防止事故发生的标准工作程序。请根据每项警告结尾提供的声明号码来找到此设备的安全性警告说明的翻译文本。

请保存这些安全性说明

警告

安全上の重要な注意事項

「危険」の意味です。人身事故を予防するための注意事項が記述されています。装置の取り扱い作業を行うときは、電気回路の危険性に注意し、一般的な事故防止策に留意してください。警告の各国語版は、各注意事項の番号を基に、装置に付属の「Translated Safety Warnings」を参照してください。

これらの注意事項を保管しておいてください。

주의

중요 안전 지침

이 경고 기호는 위험을 나타냅니다. 작업자가 신체 부상을 일으킬 수 있는 위험한 환경에 있습니다. 장비에 작업을 수행하기 전에 전기 회로와 관련된 위험을 숙지하고 표준 작업 관례를 숙지하여 사고를 방지하십시오. 각 경고의 마지막 부분에 있는 경고문 번호를 참조하여 이 장치와 함께 제공되는 번역된 안전 경고문에서 해당 번역문을 찾으십시오.

이 지시 사항을 보관하십시오.

Aviso INSTRUÇÕES IMPORTANTES DE SEGURANÇA

Este símbolo de aviso significa perigo. Você se encontra em uma situação em que há risco de lesões corporais. Antes de trabalhar com qualquer equipamento, esteja ciente dos riscos que envolvem os circuitos elétricos e familiarize-se com as práticas padrão de prevenção de acidentes. Use o número da declaração fornecido ao final de cada aviso para localizar sua tradução nos avisos de segurança traduzidos que acompanham o dispositivo.

GUARDE ESTAS INSTRUÇÕES**Advarsel VIGTIGE SIKKERHEDSANVISNINGER**

Dette advarselssymbol betyder fare. Du befinder dig i en situation med risiko for legemeskade. Før du begynder arbejde på udstyr, skal du være opmærksom på de involverede risici, der er ved elektriske kredsløb, og du skal sætte dig ind i standardprocedurer til undgåelse af ulykker. Brug erklæringsnummeret efter hver advarsel for at finde oversættelsen i de oversatte advarsler, der fulgte med denne enhed.

GEM DISSE ANVISNINGER**تحذير****إرشادات الأمان الهامة**

يوضح رمز التحذير هذا وجود خطر. وهذا يعني أنك متواجد في مكان قد ينتج عنه التعرض للإصابات. قبل بدء العمل، احذر مخاطر التعرض للصدمات الكهربائية وكن على علم بالإجراءات القياسية للحيلولة دون وقوع أي حوادث. استخدم رقم البيان الموجود في آخر كل تحذير لتحديد مكان ترجمته داخل تحذيرات الأمان المترجمة التي تأتي مع الجهاز. قم بحفظ هذه الإرشادات

Upozorenje VAŽNE SIGURNOSNE NAPOMENE

Ovaj simbol upozorenja predstavlja opasnost. Nalazite se u situaciji koja može prouzročiti tjelesne ozljede. Prije rada s bilo kojim uređajem, morate razumjeti opasnosti vezane uz električne sklopove, te biti upoznati sa standardnim načinima izbjegavanja nesreća. U prevedenim sigurnosnim upozorenjima, priloženima uz uređaj, možete prema broju koji se nalazi uz pojedino upozorenje pronaći i njegov prijevod.

SAČUVAJTE OVE UPUTE**Upozornění DŮLEŽITÉ BEZPEČNOSTNÍ POKYNY**

Tento upozorňující symbol označuje nebezpečí. Jste v situaci, která by mohla způsobit nebezpečí úrazu. Před prací na jakémkoliv vybavení si uvědomte nebezpečí související s elektrickými obvody a seznamte se se standardními opatřeními pro předcházení úrazům. Podle čísla na konci každého upozornění vyhledejte jeho překlad v přeložených bezpečnostních upozorněních, která jsou přiložena k zařízení.

USCHOVEJTE TYTO POKYNY

Προειδοποίηση ΣΗΜΑΝΤΙΚΕΣ ΟΔΗΓΙΕΣ ΑΣΦΑΛΕΙΑΣ

Αυτό το προειδοποιητικό σύμβολο σημαίνει κίνδυνο. Βρίσκεστε σε κατάσταση που μπορεί να προκαλέσει τραυματισμό. Πριν εργαστείτε σε οποιοδήποτε εξοπλισμό, να έχετε υπόψη σας τους κινδύνους που σχετίζονται με τα ηλεκτρικά κυκλώματα και να έχετε εξοικειωθεί με τις συνήθεις πρακτικές για την αποφυγή ατυχημάτων. Χρησιμοποιήστε τον αριθμό δήλωσης που παρέχεται στο τέλος κάθε προειδοποίησης, για να εντοπίσετε τη μετάφρασή της στις μεταφρασμένες προειδοποιήσεις ασφαλείας που συνοδεύουν τη συσκευή.

ΦΥΛΑΞΤΕ ΑΥΤΕΣ ΤΙΣ ΟΔΗΓΙΕΣ

הרהר

הוראות בטיחות חשובות

סימן אזהרה זה מסמל סכנה. אתה נמצא במצב העלול לגרום לפציעה. לפני שתעבוד עם ציוד כלשהו, עליך להיות מודע לסכנות הכרוכות במעגלים חשמליים ולהכיר את הנהלים המקובלים למניעת תאונות. השתמש במספר ההוראה המסופק בסופה של כל אזהרה כדי לאתר את התרגום באזהרות הבטיחות המתורגמות שמצורפות להתקן.

שמור הוראות אלה

Opomena

ВАЖНИ БЕЗБЕДНОСНИ НАПАТСТВИЈА

Симболот за предупредување значи опасност. Се наоѓате во ситуација што може да предизвика телесни повреди. Пред да работите со опремата, бидете свесни за ризикот што постои кај електричните кола и треба да ги познавате стандардните постапки за спречување на несреќни случаи. Искористете го бројот на изјавата што се наоѓа на крајот на секое предупредување за да го најдете неговиот период во преведените безбедносни предупредувања што се испорачани со уредот.

ЧУВАЈТЕ ГИ ОБИЕ НАПАТСТВИЈА

Ostrzeżenie

WAŻNE INSTRUKCJE DOTYCZĄCE BEZPIECZEŃSTWA

Ten symbol ostrzeżenia oznacza niebezpieczeństwo. Zachodzi sytuacja, która może powodować obrażenia ciała. Przed przystąpieniem do prac przy urządzeniach należy zapoznać się z zagrożeniami związanymi z układami elektrycznymi oraz ze standardowymi środkami zapobiegania wypadkom. Na końcu każdego ostrzeżenia podano numer, na podstawie którego można odszukać tłumaczenie tego ostrzeżenia w dołączonym do urządzenia dokumencie z tłumaczeniami ostrzeżeń.

NINIEJSZE INSTRUKCJE NALEŻY ZACHOWAĆ

Upozornenie

DÔLEŽITÉ BEZPEČNOSTNÉ POKYNY

Tento varovný symbol označuje nebezpečenstvo. Nachádzate sa v situácii s nebezpečenstvom úrazu. Pred prácou na akomkoľvek vybavení si uvedomte nebezpečenstvo súvisiace s elektrickými obvodmi a oboznámte sa so štandardnými opatreniami na predchádzanie úrazom. Podľa čísla na konci každého upozornenia vyhľadajte jeho preklad v preložených bezpečnostných upozorneniach, ktoré sú priložené k zariadeniu.

USCHOVAJTE SI TENTO NÁVOD

Obtaining Optical Networking Information

This section contains information that is specific to optical networking products. For information that pertains to all of Cisco, refer to the [Obtaining Documentation and Submitting a Service Request](#) section.

Where to Find Safety and Warning Information

For safety and warning information, refer to the *Cisco Optical Transport Products Safety and Compliance Information* document that accompanied the product. This publication describes the international agency compliance and safety information for the Cisco ONS 15454 system. It also includes translations of the safety warnings that appear in the ONS 15454 system documentation.

Cisco Optical Networking Product Documentation CD-ROM

Optical networking-related documentation, including Cisco ONS 15xxx product documentation, is available in a CD-ROM package that ships with your product. The Optical Networking Product Documentation CD-ROM is updated periodically and may be more current than printed documentation.

Obtaining Documentation and Submitting a Service Request

For information on obtaining documentation, obtaining support, providing documentation feedback, security guidelines, and also recommended aliases and general Cisco documents, see the monthly *What's New in Cisco Product Documentation*, which also lists all new and revised Cisco technical documentation, at:

<http://www.cisco.com/en/US/docs/general/whatsnew/whatsnew.html>

Subscribe to the What's New in Cisco Product Documentation as a Really Simple Syndication (RSS) feed and set content to be delivered directly to your desktop using a reader application. The RSS feeds are a free service and Cisco currently supports RSS version 2.0.





Install the Shelf and Common Control Cards

This chapter explains how to install the Cisco ONS 15454 ETSI and Cisco ONS 15454 ANSI shelf assemblies. Where procedures differ for the two shelf types, the procedure will indicate “ANSI only” or “ETSI only.” For a summary of the tools and equipment required for installation, see the [“Required Tools and Equipment \(ETSI\)”](#) section on page 1-5 or the [“Required Tools and Equipment \(ANSI\)”](#) section on page 1-3.



Note

Unless otherwise specified, “ONS 15454” refers to both ANSI and ETSI shelf assemblies.

Before You Begin

This section lists the chapter procedures (NTPs). Turn to a procedure for applicable tasks (DLPs). Read the installation procedures and precautions before you install the ONS 15454 ANSI or ONS 15454 ETSI and connect the power source.

1. [NTP-G1 Unpack and Inspect the Shelf Assembly, page 1-6](#)—Complete this procedure before continuing with the [“NTP-G2 Install the Shelf Assembly”](#) procedure on page 1-8.
2. [NTP-G2 Install the Shelf Assembly, page 1-8](#)—Complete this procedure to install the shelf assembly in a rack.
3. [NTP-G3 Open and Remove the Front Door, page 1-20](#)—Complete this procedure to access the equipment before continuing with other procedures in this chapter.
4. [NTP-G4 Open and Remove the FMEC Cover \(ETSI Only\), page 1-23](#)—Complete this procedure to access the electrical facility connection assembly (EFCA) for the front mount electrical connections (FMECs) before continuing with other procedures in this chapter.
5. [NTP-G5 Remove the Backplane Covers \(ANSI Only\), page 1-26](#)—Complete this procedure to access the backplane before continuing with other procedures.
6. [NTP-G6 Install the MIC-A/P and MIC-T/C/P FMECs \(ETSI Only\), page 1-28](#)—Complete this procedure to install the MIC-A/P and MIC-T/C/P FMECs, which are required for power supply as well as alarm, timing, and LAN connections.
7. [NTP-G7 Install the Power and Ground, page 1-30](#)—Complete this procedure before continuing with the [“NTP-G8 Install the Fan-Tray Assembly”](#) procedure on page 1-40.
8. [NTP-G8 Install the Fan-Tray Assembly, page 1-40](#)—Complete this procedure to install the fan-tray assembly in the shelf.

9. [NTP-G9 Install the Alarm Expansion Panel \(ANSI Only\), page 1-43](#)—Complete this procedure if you are planning to install the AIC-I card and want to increase the number of alarm contacts provided by the AIC-I card.
10. [NTP-G10 Attach Wires to Alarm, Timing, LAN, and Craft Pin Connections, page 1-46](#)—Complete as needed to set up wire-wrap pin connections.
11. [NTP-G11 Install an External Wire-Wrap Panel on the AEP \(ANSI Only\), page 1-57](#)—Complete this procedure to connect an external wire-wrap panel to the alarm expansion panel (AEP).
12. [NTP-G12 Install and Close the FMEC Cover \(ETSI Only\), page 1-61](#)—Complete this procedure to install the FMEC cover.
13. [NTP-G13 Install the Rear Cover \(ANSI Only\), page 1-62](#)—Complete this procedure as needed to install the rear cover after you have finished servicing the backplane.
14. [NTP-G14 Install DWDM Equipment, page 1-64](#)—Complete this procedure as needed to install equipment needed for DWDM networks.
15. [NTP-G15 Install the Common Control Cards, page 1-72](#)—Complete this procedure to install the TCC2/TCC2P card, the AIC-I card, and the MS-ISC-100T card.
16. [NTP-G145 Connect a Multishelf Node and Subtending Shelves to an MS-ISC-100T Card, page 1-78](#)—Complete this procedure as needed.
17. [NTP-G158 Connect a Multishelf Node and Subtending Shelves to a Cisco Catalyst 2950, page 1-80](#)—Complete this procedure as needed.
18. [NTP-G159 Configure a Cisco Catalyst 2950 for a Multishelf Node, page 1-80](#)—Complete this procedure as needed.
19. [NTP-G16 Perform the Shelf Installation Acceptance Test, page 1-82](#)—Complete this procedure to determine if you have correctly completed all other procedures in the chapter.



Warning

This warning symbol means danger. You are in a situation that could cause bodily injury. Before you work on any equipment, be aware of the hazards involved with electrical circuitry and be familiar with standard practices for preventing accidents. To see translations of the warnings that appear in this publication, refer to the Regulatory Compliance and Safety Information document for the appropriate Cisco chassis. Statement 274



Warning

Installation of the equipment must comply with local and national electrical codes. Statement 1074



Warning

This equipment must be installed and maintained by service personnel as defined by AS/NZS 3260. Incorrectly connecting this equipment to a general-purpose outlet could be hazardous. The telecommunications lines must be disconnected 1) before unplugging the main power connector or 2) while the housing is open, or both. Statement 1043



Warning

This unit is intended for installation in restricted access areas. A restricted access area can be accessed only through the use of a special tool, lock and key, or other means of security. Statement 1017

**Warning**

Ultimate disposal of this product should be handled according to all national laws and regulations.
Statement 1040

**Warning**

A readily accessible two-poled disconnect device must be incorporated in the fixed wiring.
Statement 1022

**Note**

The ONS 15454 is suitable for mounting on concrete or other noncombustible surfaces only.

**Note**

In this chapter, “shelf assembly” refers to the steel enclosure that holds cards and connects power, and “node” refers to the entire hardware and software system.

Required Tools and Equipment (ANSI)

You need the following tools and equipment to install and test the ONS 15454 ANSI shelf assembly.

Cisco-Supplied Materials (ANSI)

The following materials are required and are shipped with the ONS 15454 ANSI shelf (wrapped in plastic). The number in parentheses gives the quantity of the item included in the package.

- #12-24 x 3/4 pan-head Phillips mounting screws (48-1004-XX, 48-1007-XX) (8)
- #12 -24 x 3/4 socket set screws (48-1003-XX) (2)
- T-handle #12-24 hex tool for set screws (1)
- ESD wrist strap with 1.8 m (6 ft) coil cable (1)
- Tie wraps (10)
- Pinned hex (Allen) key for front door (1)
- Spacers (50-1193-XX) (4)
- Spacer mounting brackets (2)
- Sheet metal backplane cover (installed) (1)
- External (bottom) brackets for the fan-tray air filter
- Standoff kit (53-0795-XX):
 - Plastic fiber management guides (2)
 - Fan filter bracket screws (53-48-0003) (6)

User-Supplied Materials (ANSI)

The following materials and tools are required but are not supplied with the ONS 15454 ANSI:

- One or more of the following equipment racks:
 - 19-inch ANSI Standard (Telcordia GR-63-CORE) (482.6 mm) rack; total width 22 inches (558.8 mm)
 - 23-inch ANSI Standard (Telcordia GR-63-CORE) (584.2 mm) rack; total width 26 inches (660.4 mm)
- Fuse panel
- Power cable (from fuse and alarm panel to assembly), #10 AWG, copper conductors, 194 degrees Fahrenheit (90 degrees Celsius)
- Ground cable #6 AWG stranded
- Alarm cable pairs for all alarm connections, #22 or #24 AWG (0.51 mm² or 0.64 mm²), solid tinned
- 100-ohm shielded building integrated timing supply (BITS) clock cable pair #22 or #24 AWG (0.51 mm² or 0.64 mm²), twisted-pair T1-type
- Single-mode SC fiber jumpers with UPC polish (55 dB or better) for optical (OC-N) cards
- Shielded coaxial cable terminated with SMB or BNC connectors for DS-3 cards
- Shielded ABAM cable terminated with AMP Champ connectors or unterminated for DS1N-14 cards with #22 or #24 AWG (0.51 mm² or 0.64 mm²) ground wire (typically about two ft [61 cm] in length)
- 6-pair #29 AWG double-shielded cable
- Tie wraps and/or lacing cord
- Labels
- Listed pressure terminal connectors such as ring and fork types; connectors must be suitable for #10 AWG copper conductors

Tools Needed (ANSI)

The following tools are needed to install an ONS 15454 ANSI:

- #2 Phillips screwdriver
- Medium slot-head screwdriver
- Small slot-head screwdriver
- Wire wrapper
- Wire cutters
- Wire strippers
- Crimp tool
- BNC insertion tool

Test Equipment (ANSI)

The following test equipment is needed to install an ONS 15454 ANSI:

- Voltmeter
- Optical power meter (for use with fiber optics only)
- Bit error rate (BER) tester, DS-1 and DS-3

Required Tools and Equipment (ETSI)

You need the following tools and equipment to install and test the ONS 15454 ETSI shelf assembly.

Cisco-Supplied Equipment (ETSI)

These materials are required for installation and are supplied with the ONS 15454 ETSI. The shipped quantity of each item is in parentheses.

- Double-hole grounding lug for ground connection with a wire receptacle to accommodate the recommended 13.3 mm² (#6 AWG) multistrand copper wire (1)
- M4 x 8 mm pan-head Phillips screws (2)
- M6 x 20 mm socket set screws (2)
- M6 x 20 mm pan-head Phillips screws (8)
- Tie wraps 0.125-inch (3.2 mm) W x 6.0-inch (152 mm) L (24)
- ESD wrist strap (disposable) (1)
- Pinned hex (Allen) key for front door (1)
- Hex key 3-mm long arm (1)
- Bottom brackets for the fan-tray air filter
- Cable assembly, Ethernet, RJ-45 (1)
- Power cable (from fuse and alarm panel to MIC-A/P and MIC-C/T/P) (2)

**Caution**

Only use the power cables that are designed to be used with ONS 15454 ETSI. They are sold separately.

User-Supplied Equipment (ETSI)

The following materials and tools are required for installation but are not supplied with the ONS 15454 ETSI:

- Equipment rack (ETSI rack, 2200 mm [86.6 inch] H x 600 mm [23.6 inch] W x 300 mm [11.8 inch] D)
- Fuse and alarm panel
- Copper ground cable 13.3-mm² (#6 AWG) stranded, specified for up to 90 degrees Celsius (194 degrees Fahrenheit)
- Alarm cable pairs for all alarm connections, 0.51 mm² or 0.64 mm² (#22 or #24 AWG), solid-tinned
- Single-mode SC fiber jumpers with UPC polish (55 dB or better) for optical cards
- Coaxial cable terminated with 1.0/2.3 miniature coax connectors for FMEC cards
- DB-37 cable
- Shielded BITS clock coaxial cable terminated with 1.0/2.3 miniature coax connectors
- Labels

**Note**

Ring runs are not provided by Cisco and can hinder side-by-side shelf installation where space is limited.

Tools Needed (ETSI)

To install the ONS 15454 ETSI, you need the following tools.

- #2 Phillips screwdriver
- Medium slot-head screwdriver
- Small slot-head screwdriver
- Video fiber connector inspection instrument
- CLETOP cleaning cassette
- Crimping tool—This tool must be large enough to accommodate the girth of the grounding lug when you crimp the grounding cable into the lug.
- Wire stripping tool

Test Equipment (ETSI)

To install the ONS 15454 ETSI, you need the following test equipment.

- Voltmeter
- Power meter (only for use with fiber optics)
- BER tester for E1-N-14, E1-42, E3-12, DS3i-N-12, STM1E-12, and FMEC cards

NTP-G1 Unpack and Inspect the Shelf Assembly

Purpose	This procedure explains how to unpack the ONS 15454 shelf assemblies and verify their contents.
Tools/Equipment	Pinned hex (Allen) key for front door
Prerequisite Procedures	None
Required/As Needed	Required
Onsite/Remote	Onsite
Security Level	None

-
- Step 1** Complete the [“DLP-G1 Unpack and Verify the Shelf Assembly”](#) task on page 1-7.
- Step 2** Complete the [“DLP-G2 Inspect the Shelf Assembly”](#) task on page 1-7.
- Step 3** Continue with the [“NTP-G1 Unpack and Inspect the Shelf Assembly”](#) procedure on page 1-6.
- Stop. You have completed this procedure.**
-

DLP-G1 Unpack and Verify the Shelf Assembly

Purpose	This task removes the shelf assembly from the package.
Tools/Equipment	None
Prerequisite Procedures	None
Required/As Needed	Required
Onsite/Remote	Onsite
Security Level	None

-
- Step 1** When you receive the ONS 15454 system equipment at the installation site, open the top of the box. The Cisco Systems logo designates the top of the box.
- Step 2** Remove the foam inserts from the box. The box contains the ONS 15454 shelf (wrapped in plastic) and a smaller box of items needed for installation.
- Step 3** To remove the shelf, grasp both rings of the shelf removal strap and slowly lift the shelf out of the box.
- Step 4** Open the smaller box of installation materials, and verify that you have all items listed in the [“Required Tools and Equipment \(ETSI\)”](#) section on page 1-5 or the [“Required Tools and Equipment \(ANSI\)”](#) section on page 1-3.



Note The fan-tray assembly is shipped separately.

- Step 5** Return to your originating procedure (NTP).
-

DLP-G2 Inspect the Shelf Assembly

Purpose	This task verifies that all parts of the shelf assembly are in good condition.
Tools/Equipment	Pinned hex (Allen) key for front door
Prerequisite Procedures	DLP-G1 Unpack and Verify the Shelf Assembly, page 1-7
Required/As Needed	Required
Onsite/Remote	Onsite
Security Level	None

-
- Step 1** Open the shelf using the pinned hex key. For more information, see the [“DLP-G9 Open the Front Cabinet Compartment \(Door\)”](#) task on page 1-20.
- Step 2** Verify the following:
- The pins are not bent or broken.
 - The frame is not bent.
- Step 3** If the pins are bent or broken, or the frame is bent, call your Cisco sales engineer for a replacement.
- Step 4** Close the front door before installing.

Step 5 Return to your originating procedure (NTP).

NTP-G2 Install the Shelf Assembly

Purpose	This procedure reverses the mounting bracket and mounts shelf assemblies in a rack.
Tools/Equipment	#2 Phillips screwdriver Medium slot-head screwdriver Small slot-head screwdriver Pinned hex key ETSI only: Two M6 x 20 socket set screws Eight M6 x 20 pan-head Phillips mounting screws ANSI only: Two #12-24 x 3/4 set screws (48-1003-XX) Eight #12-24 x 3/4 pan-head Phillips mounting screws (48-1004-XX, 48-1007-XX)
Prerequisite Procedures	NTP-G1 Unpack and Inspect the Shelf Assembly, page 1-6
Required/As Needed	Required
Onsite/Remote	Onsite
Security Level	None



Warning

Stability hazard. The rack stabilizing mechanism must be in place, or the rack must be bolted to the floor before you slide the unit out for servicing. Failure to stabilize the rack can cause the rack to tip over. Statement 1048



Warning

This product requires short-circuit (overcurrent) protection, to be provided as part of the building installation. Install only in accordance with national and local wiring regulations. Statement 1045



Warning

To prevent the system from overheating, do not operate it in an area that exceeds the maximum recommended ambient temperature of: 45 degrees C (113 degrees F). Statement 1047



Warning

Take care when connecting units to the supply circuit so that wiring is not overloaded. Statement 1018

**Warning**

To prevent bodily injury when mounting or servicing this unit in a rack, you must take special precautions to ensure that the system remains stable. The following guidelines are provided to ensure your safety:

- This unit should be mounted at the bottom of the rack if it is the only unit in the rack.
- When mounting this unit in a partially filled rack, load the rack from the bottom to the top with the heaviest component at the bottom of the rack.
- If the rack is provided with stabilizing devices, install the stabilizers before mounting or servicing the unit in the rack. Statement 1006

**Warning**

To prevent airflow restriction, allow at least 1 inch (25.4 mm) of clearance around the ventilation openings.

**Warning**

The ONS 15454 must have 1 inch (25.4 mm) of airspace below the installed shelf assembly to allow air flow to the fan intake. The air ramp (the angled piece of sheet metal on top of the shelf assembly) provides this spacing and should not be modified in any way.

**Note**

The shelf, the air ramp, and the E1-75/120 conversion panel ship with the ETSI mounting brackets installed as needed for installation in an ETSI rack. If you want to install the node in a 19-inch (482.6-mm) rack, the ETSI mounting brackets of the shelf and the air ramp need to be replaced with the 19-inch (482.6-mm) mounting brackets that shipped in the ship kit.

- Step 1** (ANSI shelves only) Complete the “[DLP-G3 Reverse the Mounting Bracket to Fit a 19-inch \(482.6-mm\) Rack \(ANSI Only\)](#)” task on page 1-10 if you need to convert from a 23-inch (584.2 mm) to a 19-inch (482.6 mm) rack.
- Step 2** (ANSI shelves only) To install the air filter on the bottom of the shelf rather than below the fan-tray assembly, complete the “[DLP-G4 Install the External Brackets and Air Filter \(ANSI Only\)](#)” task on page 1-11.
- Step 3** Complete the necessary rack mount task as applicable:
- [DLP-G5 Mount the Shelf Assembly in a Rack \(One Person\)](#), page 1-13
 - [DLP-G6 Mount the Shelf Assembly in a Rack \(Two People\)](#), page 1-15
 - [DLP-G7 Mount Multiple Shelf Assemblies in a Rack](#), page 1-16
 - [DLP-G8 Install the Air Ramp](#), page 1-19
- Step 4** Continue with the “[NTP-G3 Open and Remove the Front Door](#)” procedure on page 1-20.
Stop. You have completed this procedure.

DLP-G3 Reverse the Mounting Bracket to Fit a 19-inch (482.6-mm) Rack (ANSI Only)

Purpose	This task installs the mounting bracket to convert a 23-inch (584.2 mm) rack to a 19-inch (482.6-mm) rack. This task applies to ONS 15454 ANSI shelves only.
Tools/Equipment	#2 Phillips screwdriver Medium slot-head screwdriver Small slot-head screwdriver
Prerequisite Procedures	None
Required/As Needed	As needed
Onsite/Remote	Onsite
Security Level	None



Caution

Use only the fastening hardware provided with the ONS 15454 ANSI to prevent loosening, deterioration, and electromechanical corrosion of the hardware and joined material.

Caution

When mounting the ONS 15454 in a frame with a nonconductive coating (such as paint, lacquer, or enamel) either use the thread-forming screws provided with the ONS 15454 ANSI ship kit, or remove the coating from the threads to ensure electrical continuity.

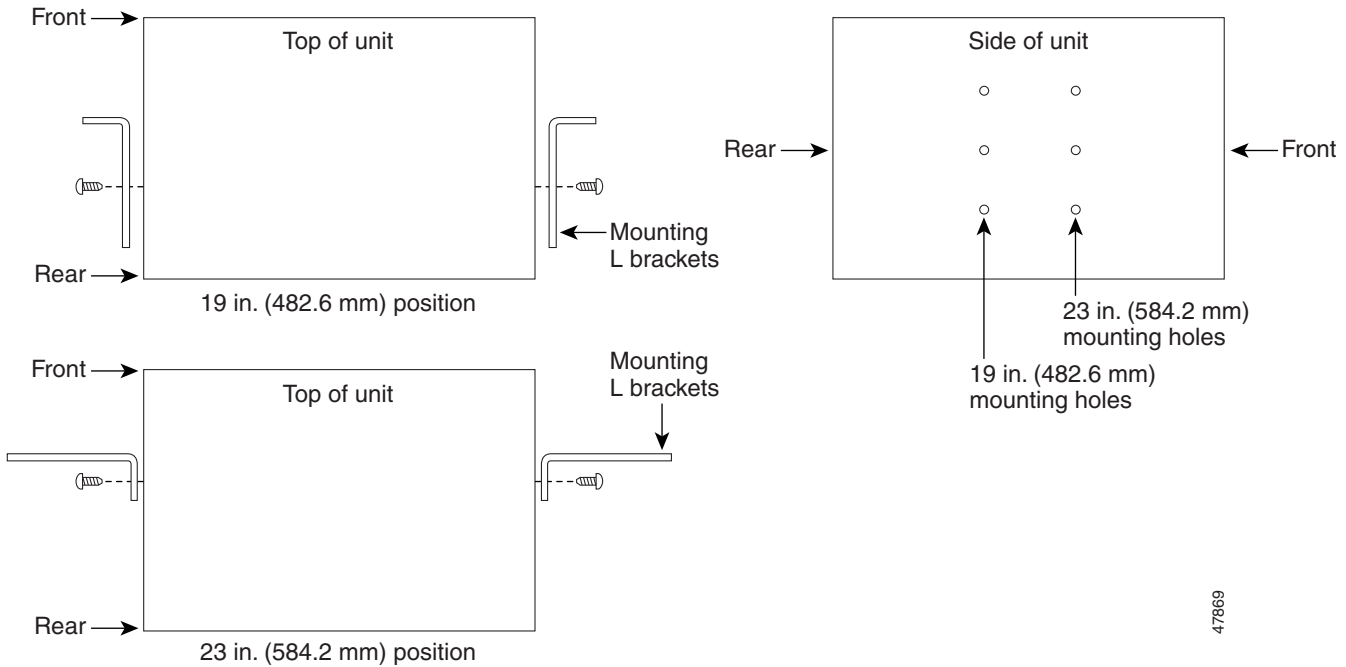
-
- Step 1** Remove the screws that attach the mounting bracket to the side of the shelf assembly.
- Step 2** Flip the detached mounting bracket upside down.
Text imprinted on the mounting bracket will now also be upside down.
- Step 3** Place the widest side of the mounting bracket flush against the shelf assembly (see [Figure 1-1](#)).
The narrow side of the mounting bracket should be towards the front of the shelf assembly. Text imprinted on the mounting bracket should be visible and upside down.
- Step 4** Align the mounting bracket screw holes against the shelf assembly screw holes.
- Step 5** Insert the screws that were removed in [Step 1](#) and tighten them.
- Step 6** Repeat the task for the mounting bracket on the opposite side.

Figure 1-1 Reversing the Mounting Brackets (23-inch [584.2-mm] Position to 19-inch [482.6-mm] Position)

Step 7 Return to your originating procedure (NTP).

DLP-G4 Install the External Brackets and Air Filter (ANSI Only)

Purpose	This task installs the external brackets and air filter on the bottom of the shelf rather than below the fan-tray assembly. Installing the external brackets and air filter on the bottom of the shelf enables access to the air filter without removing the fan-tray assembly. This task applies to the ONS 15454 ANSI shelf only.
Tools/Equipment	#2 Phillips screwdriver Medium slot-head screwdriver Small slot-head screwdriver
Prerequisite Procedures	DLP-G3 Reverse the Mounting Bracket to Fit a 19-inch (482.6-mm) Rack (ANSI Only) , page 1-10, if applicable
Required/As Needed	As needed
Onsite/Remote	Onsite
Security Level	None



Note

If you choose not to install the brackets, install the air filter by sliding it into the compartment at the bottom of the shelf assembly. Each time you remove and reinstall the air filter in the future, you must first remove the fan-tray assembly. Do not install an air filter in both filter locations on any shelf assembly.

Step 1 With the fan-tray assembly removed, place the ONS 15454 facedown on a flat surface.



Note Although the filter will work if it is installed with either side facing up, Cisco recommends that you install it with the metal bracing facing up to preserve the surface of the filter.

Step 2 Locate the three screw holes that run along the left and right sides of the bottom of the shelf assembly.

Step 3 Secure each bracket to the bottom of the shelf assembly using the screws (48-0003) provided in the backplane standoff kit (53-0795-XX).

Each bracket has a filter stopper and a flange on one end. Make sure to attach the brackets with the stoppers and flanges facing the rear of the shelf assembly (the top, if the ONS 15454 is facedown during installation).

Figure 1-2 illustrates bottom bracket installation. If you do not use the brackets, in the future you must remove the fan-tray assembly before removing the air filter. The brackets enable you to clean and replace the air filter without removing the fan-tray assembly.

Figure 1-2 Installing the External Brackets

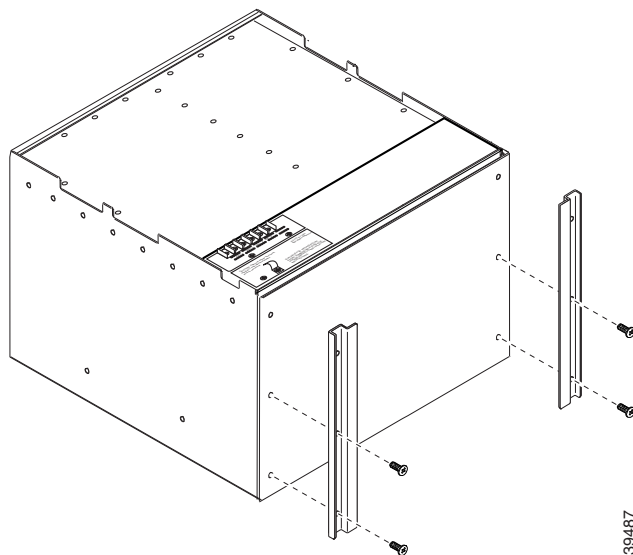

Step 4 Slide the air filter into the shelf assembly.

Step 5 Return to your originating procedure (NTP).

DLP-G5 Mount the Shelf Assembly in a Rack (One Person)

Purpose	This task allows one person to mount the shelf assembly in a rack.
Tools/Equipment	<p>Pinned hex key</p> <p># 2 Phillips screwdriver</p> <p>ETSI only:</p> <p>Two M6 x 20 socket set screws</p> <p>Eight M6 x 20 pan-head Phillips mounting screws</p> <p>ANSI only:</p> <p>Two #12-24 x 3/4 set screws (48-1003-XX)</p> <p>Eight #12-24 x 3/4 pan-head Phillips mounting screws (48-1004-XX, 48-1007-XX)</p>
Prerequisite Procedures	NTP-G1 Unpack and Inspect the Shelf Assembly, page 1-6
Required/As Needed	As needed
Onsite/Remote	Onsite
Security Level	None



Note

The ONS 15454 ETSI requires 616.5 mm (24.24 inch) minimum of vertical rack space and 25 mm (1 inch) below the installed shelf assembly to allow air flow to the fan intake. If a second ONS 15454 ETSI is installed above a shelf assembly, the air ramp between the shelves provides space for air flow. To ensure that the mounting is secure, use two to four M6 mounting screws for each side of the shelf assembly. A shelf assembly should be mounted at the bottom of the rack if it is the only unit in the rack.

- Step 1** Verify that the proper fuse and alarm panel has been installed in the top mounting space. If a fuse and alarm panel is not present, you must install one according to manufacturer instructions:
- (ETSI only) Verify that the fuse rating does not exceed 30A.
 - The fuse rating for ANSI chassis must not exceed 30A.
- Step 2** Ensure that the shelf assembly is set for the desired rack size (either 23 inches [584.2 mm] or 19 inches [482.6 mm]).

Figure 1-3 shows the rack-mounting position for the ONS 15454 ETSI.

Figure 1-3 Mounting an ONS 15454 ETSI in a Rack

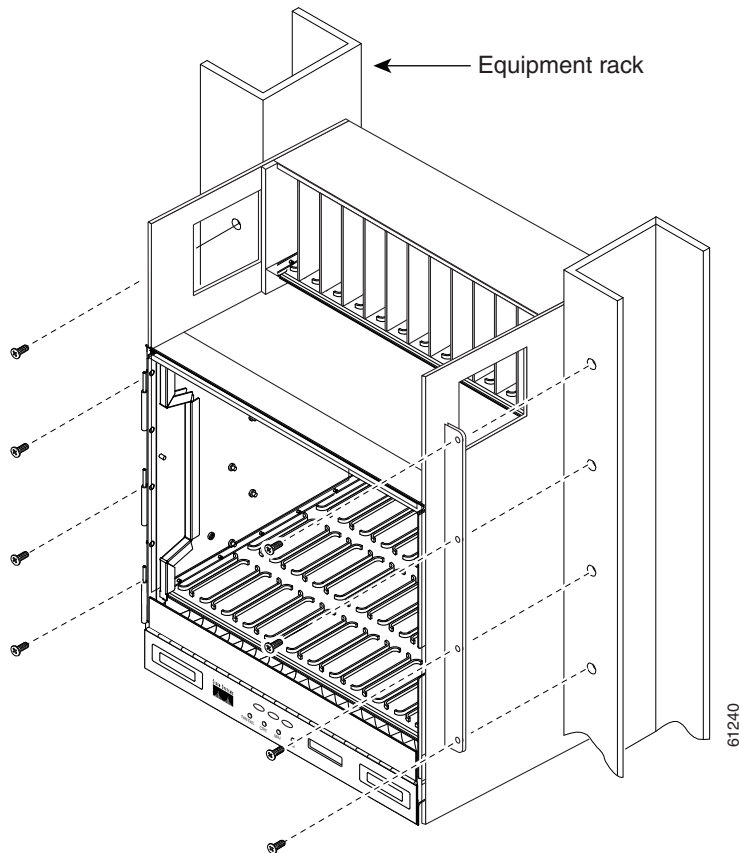

- Step 3** Using the hex tool that shipped with the assembly, install the two temporary set screws into the holes that will not be used to mount the shelf. Let the set screws protrude sufficiently to hold the mounting brackets.
- Step 4** Lift the shelf assembly to the desired position in the rack and set it on the screws.
- Step 5** Align the screw holes on the mounting brackets with the mounting holes in the rack.
- Step 6** Using the Phillips screwdriver, install one mounting screw in each side of the assembly.
- Step 7** When the shelf assembly is secured to the rack, install the remaining mounting screws.



Note Use at least one set of the horizontal screw slots on the shelf assembly to prevent slippage.

- Step 8** Using the hex tool, remove the temporary set screws.
- Step 9** Return to your originating procedure (NTP).

DLP-G6 Mount the Shelf Assembly in a Rack (Two People)

Purpose	This task allows two people to mount the shelf assembly in a rack.
Tools/Equipment	<p>Pinned hex key</p> <p># 2 Phillips screwdriver</p> <p>ETSI only:</p> <p>Two M6 x 20 socket set screws</p> <p>Eight M6 x 20 pan-head Phillips mounting screws</p> <p>ANSI only:</p> <p>Two #12-24 x 3/4 set screws (48-1003-XX)</p> <p>Eight #12-24 x 3/4 pan-head Phillips mounting screws (48-1004-XX, 48-1007-XX)</p>
Prerequisite Procedures	NTP-G1 Unpack and Inspect the Shelf Assembly, page 1-6
Required/As Needed	As needed
Onsite/Remote	Onsite
Security Level	None



Note

The ONS 15454 ETSI requires 616.5 mm (24.24 inch) minimum of vertical rack space and 25 mm (1 inch) below the installed shelf assembly to allow air flow to the fan intake. If a second ONS 15454 ETSI is installed above a shelf assembly, the air ramp between the shelves provides space for air flow. To ensure that the mounting is secure, use two to four M6 mounting screws for each side of the shelf assembly. A shelf assembly should be mounted at the bottom of the rack if it is the only unit in the rack.



Note

The ONS 15454 ANSI must have one inch (25.4 mm) of airspace below the installed shelf assembly to allow air flow to the fan intake. If a second ONS 15454 is installed underneath a shelf assembly, the air ramp on top of the bottom shelf assembly provides the desired space. However, if the ONS 15454 is installed above third-party equipment, you must provide a minimum spacing of one inch (25.4 mm) between the third-party shelf assembly and the bottom of the ONS 15454. The third-party equipment must not vent heat upward into the ONS 15454.

- Step 1** Verify that the proper fuse and alarm panel has been installed in the top mounting space. If a fuse and alarm panel is not present, you must install one according to manufacturer's instructions:
- (ETSI only) Verify that the fuse rating does not exceed 30A.
 - The fuse rating for ANSI chassis must not exceed 30A.
- Step 2** Ensure that the shelf assembly is set for the desired rack size (either 23 inches [584.2 mm] or 19 inches [482.6 mm]).
- Step 3** Using the hex tool that shipped with the assembly, install the two set screws into the holes that will not be used to mount the shelf. Let the set screws protrude sufficiently to hold the mounting brackets.
- Step 4** Lift the shelf assembly to the desired position in the rack.
- Step 5** Align the screw holes on the mounting brackets with the mounting holes in the rack.

Step 6 Have one person hold the shelf assembly in place while the other person uses the Phillips screwdriver to install one mounting screw in each side of the assembly.

Step 7 When the shelf assembly is secured to the rack, install the remaining mounting screws.



Note Use at least one set of the horizontal screw slots on the shelf assembly to prevent slippage.

Step 8 Use the hex tool to remove the temporary set screws.

Step 9 Return to your originating procedure (NTP).

DLP-G7 Mount Multiple Shelf Assemblies in a Rack

Purpose	This task installs multiple shelves in a rack.
Tools/Equipment	<p>Pinned hex key</p> <p>#2 Phillips screwdriver</p> <p>ETSI only:</p> <p>Two M6 x 20 socket set screws (per shelf)</p> <p>Eight M6 x 20 pan-head Phillips mounting screws (per shelf)</p> <p>ANSI only:</p> <p>Two #12-24 x 3/4 set screws (48-1003-XX) (per shelf)</p> <p>Eight #12-24 x 3/4 pan-head Phillips mounting screws (48-1004-XX, 48-1007-XX) (per shelf)</p>
Prerequisite Procedures	NTP-G1 Unpack and Inspect the Shelf Assembly, page 1-6
Required/As Needed	As needed
Onsite/Remote	Onsite
Security Level	None



Note

A standard ETSI rack can hold three ONS 15454 ETSI shelf assemblies and two air ramps. When mounting a shelf assembly in a partially filled rack, load the rack from the bottom to the top with the heaviest component at the bottom of the rack. If the rack is provided with stabilizing devices, install the stabilizers before mounting or servicing the unit in the rack.



Note

The ONS 15454 ETSI requires 616.5 mm (24.24 inch) minimum of vertical rack space and 25 mm (1 inch) below the installed shelf assembly to allow air flow to the fan intake. If a second ONS 15454 ETSI is installed above a shelf assembly, the air ramp between the shelves provides space for air flow. When using third-party equipment above the ONS 15454 ETSI, provide a minimum of 25 mm (1 inch) between the third-party unit and the bottom of the ONS 15454 ETSI. The third-party equipment must not vent heat upward into the ONS 15454 ETSI.

**Note**

The ONS 15454 ANSI must have one inch (25.4 mm) of airspace below the installed shelf assembly to allow air flow to the fan intake. If a second ONS 15454 is installed underneath a shelf assembly, the air ramp on top of the bottom shelf assembly provides the desired space. However, if the ONS 15454 is installed above third-party equipment, you must provide a minimum spacing of one inch (25.4 mm) between the third-party shelf assembly and the bottom of the ONS 15454. The third-party equipment must not vent heat upward into the ONS 15454.

- Step 1** Verify that the proper fuse and alarm panel has been installed in the top mounting space. If a fuse and alarm panel is not present, you must install one according to manufacturer's instructions:
- (ETSI only) Verify that the fuse rating does not exceed 30A.
 - The fuse rating for ANSI chassis must not exceed 30A.
- Step 2** Mount the first shelf assembly in the bottom of the rack using the [“DLP-G5 Mount the Shelf Assembly in a Rack \(One Person\)”](#) task on page 1-13 or the [“DLP-G6 Mount the Shelf Assembly in a Rack \(Two People\)”](#) task on page 1-15.

Figure 1-4 shows a three-shelf ONS 15454 ETSI bay assembly.

Figure 1-4 Three-Shelf ONS 15454 ETSI (15454 SDH) Bay Assembly

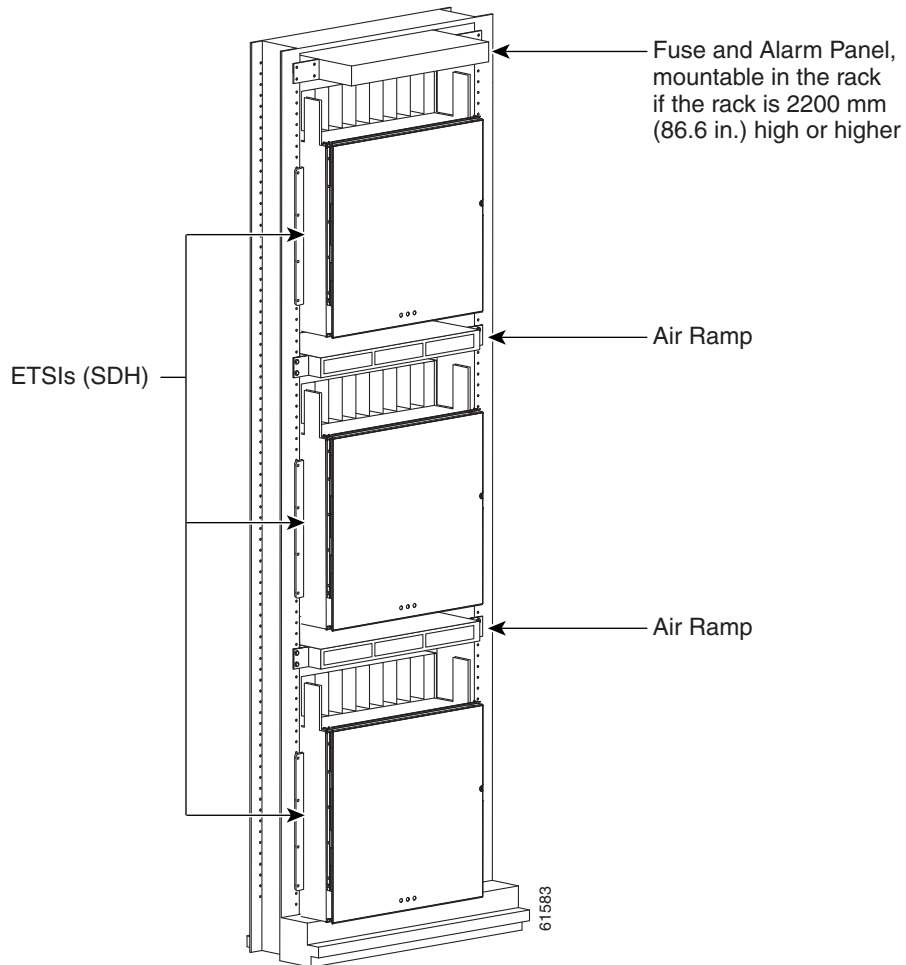

Step 3 (ETSI only) Mount the air ramp above the ONS 15454 ETSI.

The air ramp is needed if you install more than one ONS 15454 ETSI shelf in a rack. To ensure that the air ramp is secure, use one or two M6 mounting screws for each side of the shelf assembly. Figure 1-5 shows how to mount an air ramp in the rack.

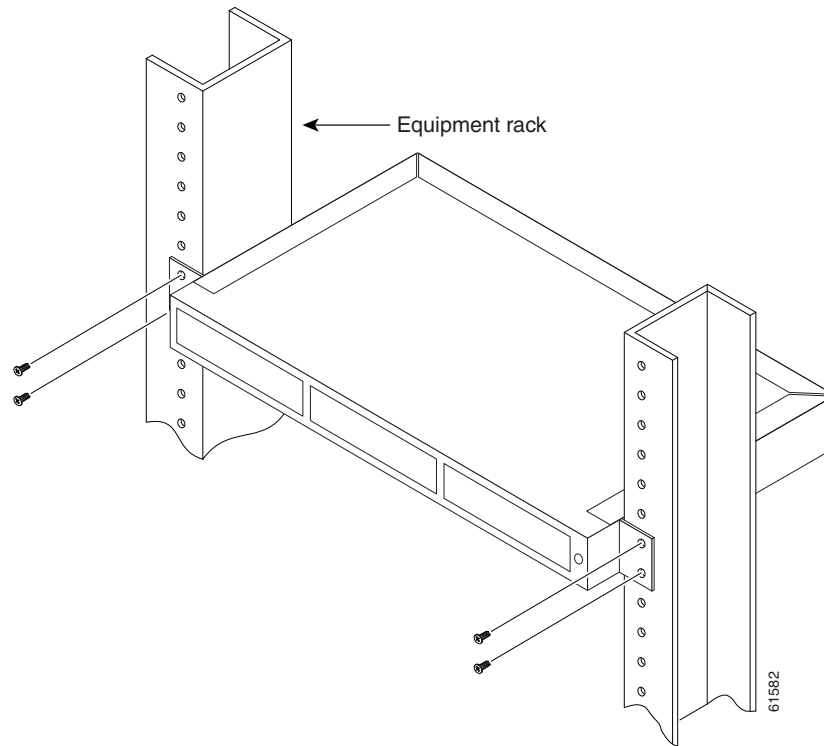
Figure 1-5 Mounting the Air Ramp in a Rack

Step 4 Repeat this task for every shelf assembly you need to install.

Step 5 Return to your originating procedure (NTP).

DLP-G8 Install the Air Ramp

Purpose	Use this task to install the air ramp.
Tools/Equipment	#2 Phillips screwdriver
Prerequisite Procedures	None
Required/As Needed	As needed
Onsite/Remote	Onsite
Security Level	None

- Step 1** The air ramp requires 1 RU in a standard 19-inch (482.6-mm) or 23-inch (584.2-mm) rack. Locate the RMU space specified in your site plan. Refer to the “Shelf Assembly Hardware” chapter in the *Cisco ONS 15454 DWDM Reference Manual* for more information about air ramp placement.
- Step 2** Verify that the mounting brackets attached to the unit are correct for your rack size. Complete the [“DLP-G3 Reverse the Mounting Bracket to Fit a 19-inch \(482.6-mm\) Rack \(ANSI Only\)”](#) task on page 1-10 as required.
- Step 3** Align the chassis with the rack mounting screw holes; insert and tighten the four screws.

Step 4 Return to your originating procedure (NTP).

NTP-G3 Open and Remove the Front Door

Purpose	This procedure opens and removes the front door to access the equipment.
Tools/Equipment	Open-end wrench Pinned hex (Allen) key
Prerequisite Procedures	NTP-G2 Install the Shelf Assembly, page 1-8
Required/As Needed	Required
Onsite/Remote	Onsite
Security Level	None

Step 1 Complete the “[DLP-G9 Open the Front Cabinet Compartment \(Door\)](#)” task on page 1-20.

Step 2 Complete the “[DLP-G10 Remove the Front Door](#)” task on page 1-21.

Step 3 If you are using an ETSI shelf, continue with the “[NTP-G4 Open and Remove the FMEC Cover \(ETSI Only\)](#)” procedure on page 1-23. If you are using an ANSI shelf, continue with the “[NTP-G5 Remove the Backplane Covers \(ANSI Only\)](#)” procedure on page 1-26.

Stop. You have completed this procedure.

DLP-G9 Open the Front Cabinet Compartment (Door)

Purpose	This task opens the front door.
Tools/Equipment	Pinned hex (Allen) key
Prerequisite Procedures	NTP-G2 Install the Shelf Assembly, page 1-8
Required/As Needed	Required
Onsite/Remote	Onsite
Security Level	None



Note

The ONS 15454 shelf assembly has an ESD plug input and is shipped with an ESD wrist strap. The ESD plug input is located on the outside of the shelf assembly on the right side. It is labeled “ESD” on the top and bottom. Always wear an ESD wrist strap and connect the strap to the ESD plug when working on the ONS 15454.

Step 1 Open the front door lock.

The ONS 15454 shelf assembly comes with a pinned hex key for locking and unlocking the front door. Turn the key counterclockwise to unlock the door and clockwise to lock it. [Figure 1-6](#) illustrates the front door of the ANSI shelf.

Figure 1-6 Cisco ONS 15454 ANSI Front Door

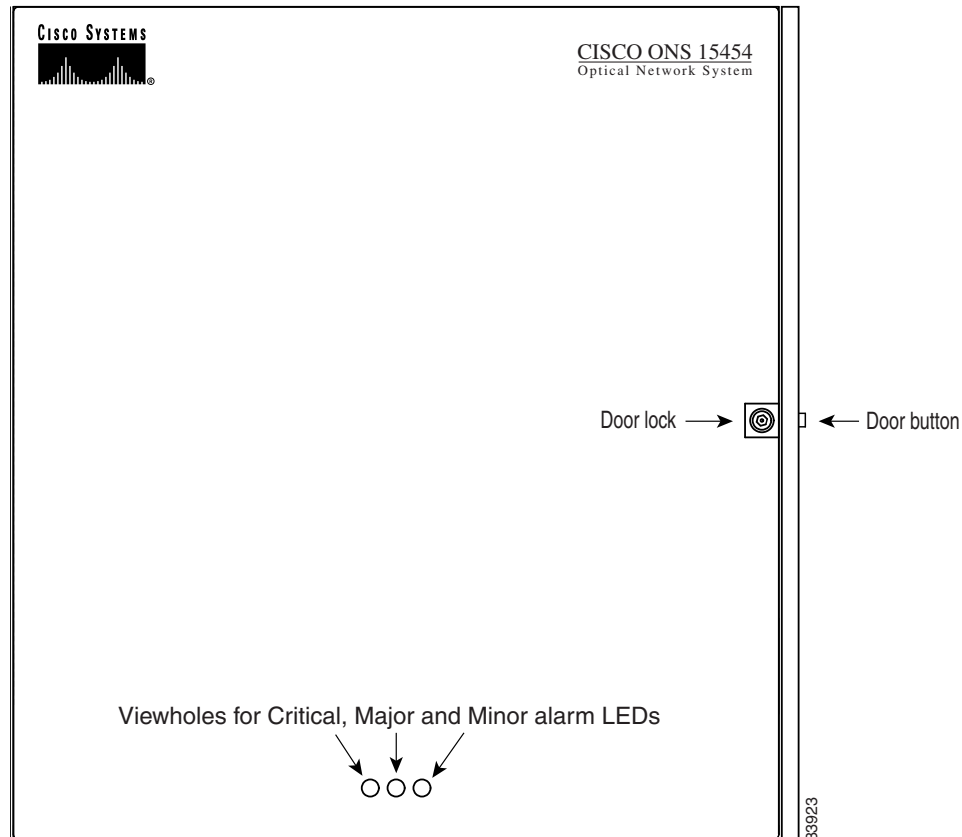

- Step 2** Press the door button to release the latch. A button on the right side of the shelf assembly releases the door.
- Step 3** Swing the door open.
- Step 4** Return to your originating procedure (NTP).

DLP-G10 Remove the Front Door

Purpose	This task removes the front cabinet compartment door.
Tools/Equipment	Open-end wrench
Prerequisite Procedures	DLP-G9 Open the Front Cabinet Compartment (Door) , page 1-20
Required/As Needed	As needed
Onsite/Remote	Onsite
Security Level	None

- Step 1** For ONS 15454 ETSI shelves:
- Unscrew the nut holding the ground wire to the shelf. Remove the nut and washer.

- b. Remove the ground wire from the shelf.
- c. Hold the door at the top left corner and remove the door from its hinges (Figure 1-7).

Figure 1-7 Removing the ONS 15454 ETSI Front Door

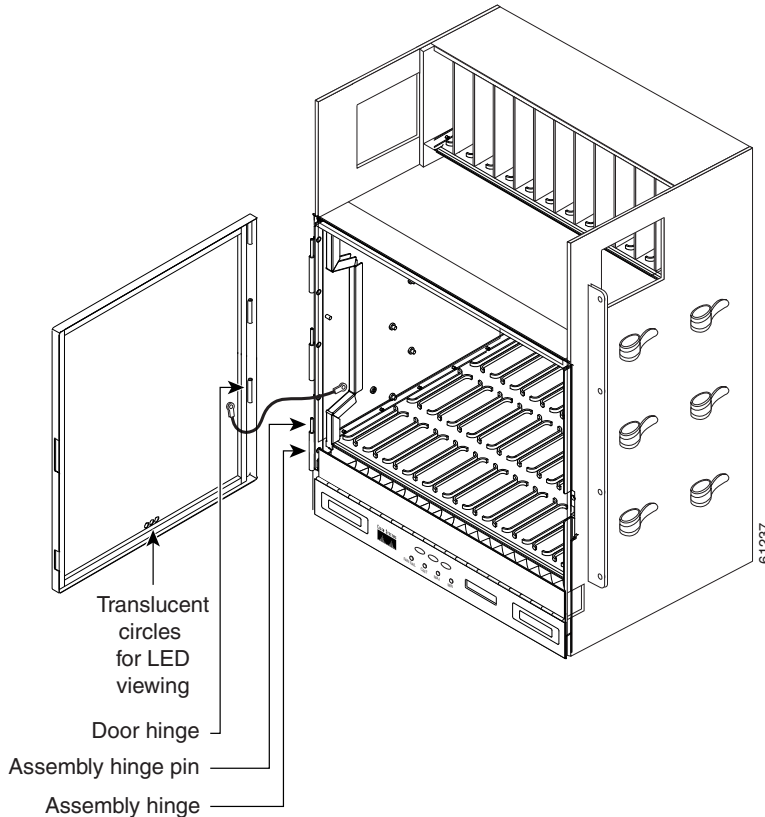

Step 2 For ONS 15454 ANSI shelves:

- a. To remove the door ground strap, perform the following:
 - To detach the ground strap from the front door, loosen the #6 Kepnut (49-0600-01) using the open-end wrench. Detach the end of the ground strap terminal lug (72-3622-01) from the male stud on the inside of the door.
 - To detach the other end of the ground strap from the longer screw on the fiber guide, loosen the #4 Kepnut (49-0337-01) on the terminal lug using the open-end wrench. Remove the terminal lug and lock washer.
- b. Lift the door from its hinges at the top left corner of the door (Figure 1-8).

Figure 1-8 Removing the ONS 15454 ANSI Front Door

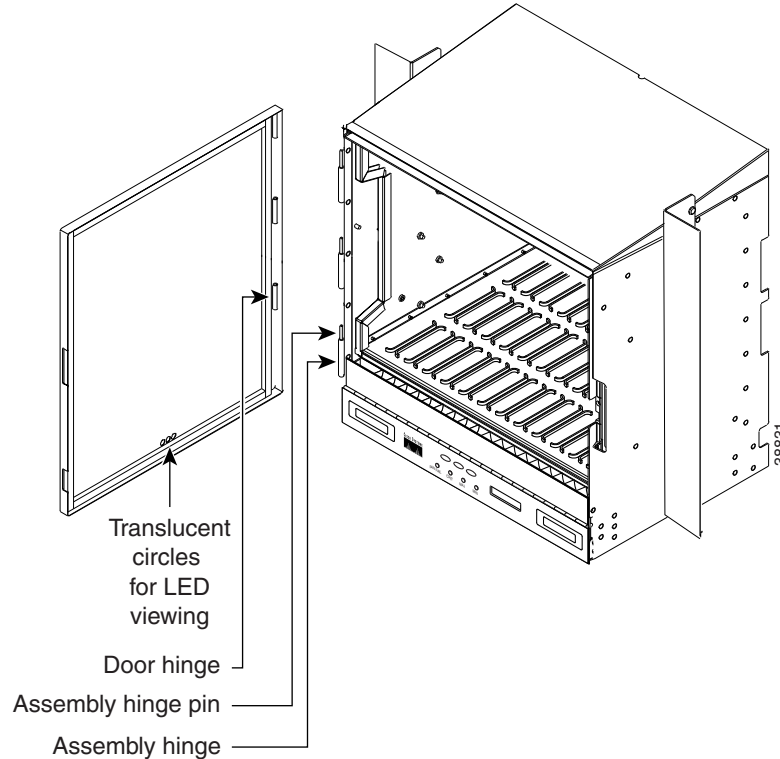

Step 3 Return to your originating procedure (NTP).

NTP-G4 Open and Remove the FMEC Cover (ETSI Only)

Purpose	This procedure opens and removes the FMEC cover on the ONS 15454 ETSI. The ONS 15454 ETSI has a screw-in panel over the EFCA. The FMEC cover protects the FMEC cards.
Tools/Equipment	Medium slot-head screwdriver
Prerequisite Procedures	NTP-G2 Install the Shelf Assembly, page 1-8
Required/As Needed	Required
Onsite/Remote	Onsite
Security Level	None

- Step 1** Complete the “[DLP-G11 Open the FMEC Cover](#)” task on page 1-24.
- Step 2** Complete the “[DLP-G12 Remove the FMEC Cover](#)” task on page 1-25.
- Step 3** Continue with the “[NTP-G6 Install the MIC-A/P and MIC-T/C/P FMECs \(ETSI Only\)](#)” procedure on page 1-28.

Stop. You have completed this procedure.

DLP-G11 Open the FMEC Cover

Purpose	This task opens the FMEC cover. The FMEC cover must be opened to install the MIC-A/P and the MIC-C/T/P.
Tools/Equipment	Medium slot-head screwdriver
Prerequisite Procedures	DLP-G9 Open the Front Cabinet Compartment (Door) , page 1-20
Required/As Needed	Required
Onsite/Remote	Onsite
Security Level	None

- Step 1** Unscrew the screws on the FMEC cover ([Figure 1-9](#)).

Figure 1-9 *Unscrewing the FMEC Cover*

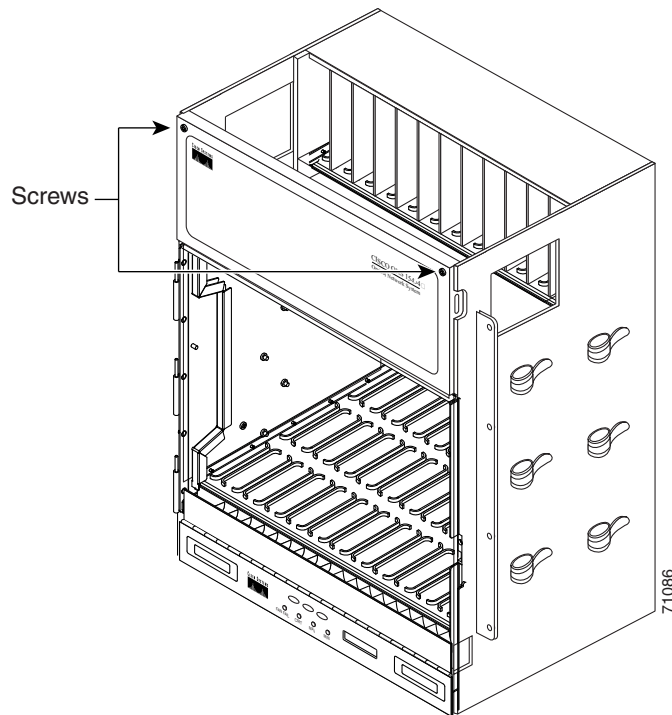

- Step 2** Use the handles to pull the cover forward.
- Step 3** Return to your originating procedure (NTP).
-

DLP-G12 Remove the FMEC Cover

Purpose	This task removes the FMEC cover in order to install the MIC-A/P and the MIC-C/T/P.
Tools/Equipment	Medium slot-head screwdriver
Prerequisite Procedures	DLP-G11 Open the FMEC Cover, page 1-24
Required/As Needed	As needed
Onsite/Remote	Onsite
Security Level	None

-
- Step 1** Unscrew the nut holding the ground wire to the shelf. Remove the nut and washer.
- Step 2** Remove the ground wire from the left side of the shelf.
- Step 3** Pull the right side of the hinge-locking spring ([Figure 1-10](#)).

Figure 1-10 Removing the ONS 15454 FMEC Cover

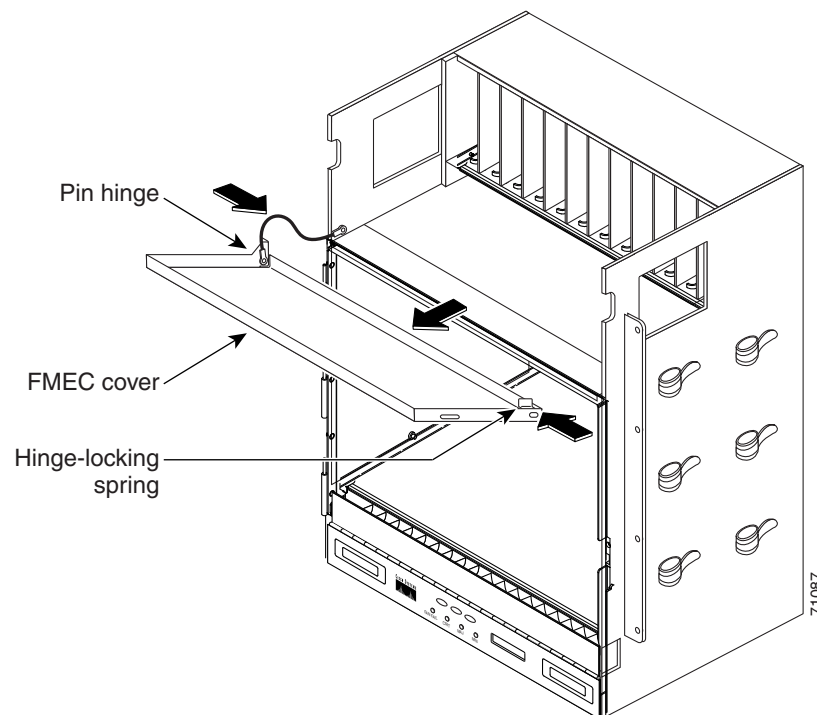

- Step 4** Detach the cover from the pin of the hinge.
- Step 5** Remove the cover carefully from the left pin of the hinge.
- Step 6** Return to your originating procedure (NTP).
-

NTP-G5 Remove the Backplane Covers (ANSI Only)

Purpose	This procedure describes how to access the ONS 15454 ANSI backplane by removing the covers. The backplane has two sheet metal covers (one on either side) and a lower backplane cover at the bottom.
Tools/Equipment	#2 Phillips screwdriver Medium slot-head screwdriver Small slot-head screwdriver
Prerequisite Procedures	NTP-G2 Install the Shelf Assembly, page 1-8 NTP-G3 Open and Remove the Front Door, page 1-20
Required/As Needed	Required
Onsite/Remote	Onsite
Security Level	None

- Step 1** Complete the “[DLP-G13 Remove the Lower Backplane Cover](#)” task on page 1-27.
- Step 2** Complete the “[DLP-G14 Remove the Backplane Sheet Metal Cover](#)” task on page 1-27.

[Figure 1-11](#) shows the location of the backplane covers.

Figure 1-11 Backplane Covers on the 15454 ANSI Shelf

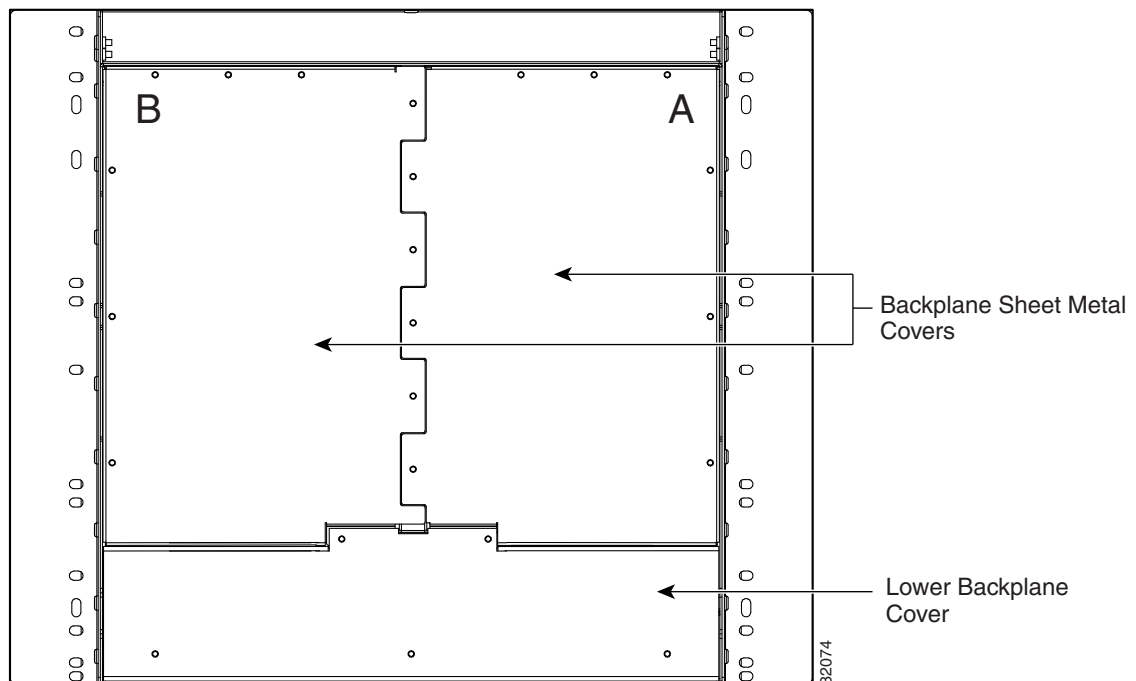

- Step 3** Continue with the “[NTP-G7 Install the Power and Ground](#)” procedure on page 1-30.
- Stop. You have completed this procedure.**

DLP-G13 Remove the Lower Backplane Cover

Purpose	This task removes the lower backplane cover of the ONS 15454 ANSI shelf assembly.
Tools/Equipment	#2 Phillips screwdriver Medium slot-head screwdriver Small slot-head screwdriver
Prerequisite Procedures	None
Required/As Needed	Required
Onsite/Remote	Onsite
Security Level	None

- Step 1** Unscrew the five retaining screws that hold the cover in place ([Figure 1-11](#)).

Figure 1-12 Lower Backplane Cover

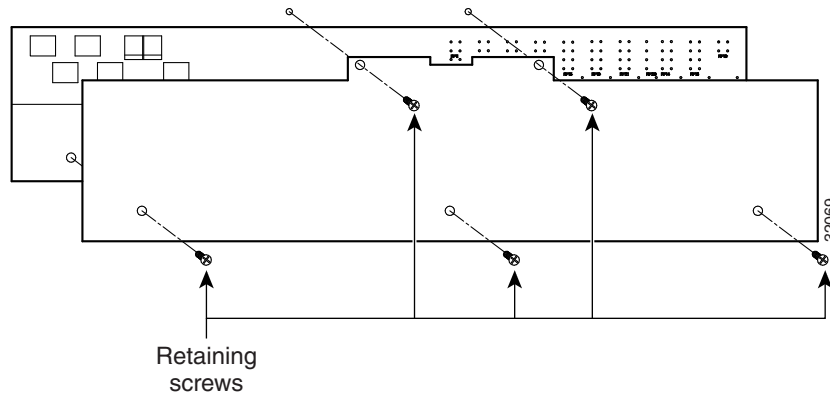

- Step 2** Grasp the cover on each side.
- Step 3** Gently pull the cover away from the backplane.
- Step 4** Return to your originating procedure (NTP).

DLP-G14 Remove the Backplane Sheet Metal Cover

Purpose	This task removes the backplane sheet metal cover that is installed on the rear of the ONS 15454 ANSI shelf.
Tools/Equipment	#2 Phillips screwdriver Medium slot-head screwdriver Small slot-head screwdriver
Prerequisite Procedures	DLP-G13 Remove the Lower Backplane Cover, page 1-27
Required/As Needed	Required

Onsite/Remote	Onsite
Security Level	None

-
- Step 1** To remove the backplane sheet metal cover, loosen the five screws that secure it to the ONS 15454 ANSI shelf and pull it away from the shelf assembly.
- Step 2** Loosen the nine perimeter screws that hold the backplane sheet metal cover(s) in place.
- Step 3** Lift the panel by the bottom to remove it from the shelf assembly.
- Step 4** Store the panel for later use. Attach the backplane cover(s) whenever electrical interface assemblies (EIAs) are not installed.
- Step 5** Return to your originating procedure (NTP).
-

NTP-G6 Install the MIC-A/P and MIC-T/C/P FMECs (ETSI Only)

Purpose	This procedure installs the MIC-A/P and the MIC-T/C/P, which are a type of FMEC installed in the EFCA. The EFCA is located at the top of the ONS 15454 ETSI shelf. It provides connection for installing power, external alarms, timing input and output, and craft interface terminals. This procedure applies to the ETSI shelf only.
Tools/Equipment	#2 Phillips screwdriver Medium slot-head screwdriver Small slot-head screwdriver FMECs (the MIC-A/P and MIC-T/C/P)
Prerequisite Procedures	NTP-G4 Open and Remove the FMEC Cover (ETSI Only), page 1-23
Required/As Needed	Required
Onsite/Remote	Onsite
Security Level	None



Warning

Voltage is present on the backplane when the system is operating. To reduce risk of an electric shock, keep hands and fingers out of the power supply bays and backplane areas. Statement 166



Caution

Always use the supplied ESD wristband when working with a powered ONS 15454 ETSI. Plug the wristband cable into the ESD jack located on the lower-right outside edge of the shelf assembly.



Note

The ONS 15454 ETSI EFCA has 12 FMEC slots numbered sequentially from left to right beginning with Slot 18. Slots 18 to 22 and 25 to 29 provide electrical connections for the corresponding slots, so they are unnecessary in dense wavelength division multiplexing (DWDM) applications.

-
- Step 1** Ensure you are installing the FMECs in the correct slot:
- FMEC Slot 23 supports the MIC-A/P.

The MIC-A/P card provides connection for the BATTERY B input, one of the two possible redundant power supply inputs. It also provides connection for eight alarm outputs (coming from the TCC2/TCC2P card), sixteen alarm inputs, and four configurable alarm inputs/outputs.

- FMEC Slot 24 supports the MIC-C/T/P.

The MIC-C/T/P card provides connection for the BATTERY A input, one of the two possible redundant power supply inputs. It also provides connection for system management serial port, system management LAN port, and system timing inputs and outputs.

- Step 2** Hold the FMEC by the faceplate.
- Step 3** Slide the FMEC along the guide rails into the desired FMEC slot or slots.
- Step 4** Push the FMEC gently into the connector. The ONS 15454 ETSI FMECs plug into electrical connectors on the back panel of the shelf assembly when the screws are tightened. [Figure 1-13](#) shows FMEC installation.

Figure 1-13 Installing FMECs on the ONS 15454 ETSI

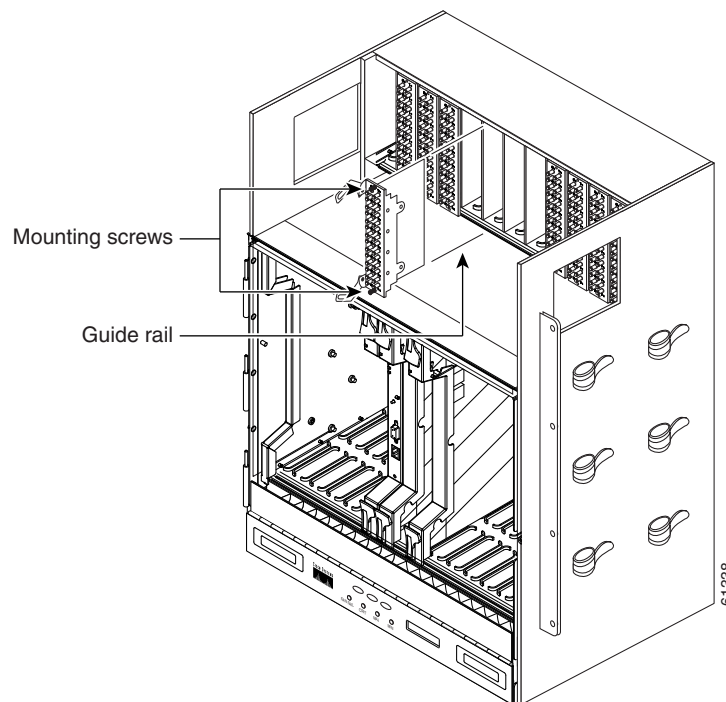

- Step 5** Tighten the screws.
- Step 6** Continue with the “[NTP-G7 Install the Power and Ground](#)” procedure on page 1-30.
- Stop. You have completed this procedure.**

NTP-G7 Install the Power and Ground

Purpose	This procedure installs power feeds and grounds the ONS 15454.
Tools/Equipment	<p>ANSI and ETSI:</p> <ul style="list-style-type: none"> • #2 Phillips screwdriver • Medium slot-head screwdriver • Small slot-head screwdriver • Screws • Ground cable 13.3-mm² (#6 AWG) stranded • Listed pressure terminal connectors such as ring and fork types; connectors must be suitable for #10 AWG copper conductors • Wire cutters • Wire strippers • Crimp tool • Fuse panel <p>ANSI only:</p> <ul style="list-style-type: none"> • Power cable (from fuse and alarm panel to assembly), #10 AWG, copper conductors, 194 degrees F [90 degrees C] • Wire wrapper <p>ETSI only:</p> <ul style="list-style-type: none"> • Power cable (from fuse panel to MIC-A/P and to MIC-C/T/P), shipped with the ONS 15454 ETSI • Two-hole grounding lug, shipped with the ONS 15454 ETSI
Prerequisite Procedures	<p>NTP-G4 Open and Remove the FMEC Cover (ETSI Only), page 1-23</p> <p>NTP-G6 Install the MIC-A/P and MIC-T/C/P FMECs (ETSI Only), page 1-28</p> <p>NTP-G5 Remove the Backplane Covers (ANSI Only), page 1-26</p>
Required/As Needed	Required
Onsite/Remote	Onsite
Security Level	None



Warning

Before performing any of the following procedures, ensure that power is removed from the DC circuit. Statement 1003



Warning

This equipment is intended to be grounded. Ensure that the host is connected to earth ground during normal use. Statement 39



Warning

Use copper conductors only. Statement 1025



Connect the unit only to DC power source that complies with the safety extra-low voltage (SELV) requirements in IEC 60950 based safety standards. Statement 1033



This product requires short-circuit (overcurrent) protection, to be provided as part of the building installation. Install only in accordance with national and local wiring regulations. Statement 1045



A readily accessible two-poled disconnect device must be incorporated in the fixed wiring. Statement 1022



This unit might have more than one power supply connection. All connections must be removed to de-energize the unit. Statement 1028



Always use the supplied ESD wristband when working with a powered ONS 15454. Plug the wristband cable into the ESD jack located on the lower-right outside edge of the shelf assembly.

-
- Step 1** Verify that the correct fuse and alarm panel is installed in the top mounting space:
- (ETSI only) Verify that the fuse rating does not exceed 30A.
 - The fuse rating for ANSI chassis must not exceed 30A.
- Step 2** Depending on your type of shelf, complete the [“DLP-G15 Connect the Office Ground to the ONS 15454 ETSI”](#) task on page 1-32 or the [“DLP-G16 Connect the Office Ground to the ONS 15454 ANSI”](#) task on page 1-33.
- Step 3** Depending on your shelf, complete the [“DLP-G17 Connect Office Power to the ONS 15454 ETSI”](#) task on page 1-35 or the [“DLP-G18 Connect Office Power to the ONS 15454 ANSI”](#) task on page 1-36.
- Step 4** Complete the [“DLP-G19 Turn On and Verify Office Power”](#) task on page 1-39.
- Step 5** Continue with the [“NTP-G8 Install the Fan-Tray Assembly”](#) procedure on page 1-40.
- Stop. You have completed this procedure.**
-

DLP-G15 Connect the Office Ground to the ONS 15454 ETSI

Purpose	This task connects ground to the ONS 15454 ETSI shelf.
Tools/Equipment	<p>2-hole grounding lug, included in the installation kit</p> <p>2 Phillips head, M6 (metric) machine screws with locking washers, included in the installation kit</p> <p>Grounding wire—Use 13.3-mm² (#6 AWG) copper wire.</p> <p>#2 Phillips screwdriver</p> <p>Crimping tool—This tool must be large enough to accommodate the girth of the grounding lug when you crimp the grounding cable into the lug.</p> <p>Wire stripping tool</p>
Prerequisite Procedures	DLP-G9 Open the Front Cabinet Compartment (Door) , page 1-20
Required/As Needed	Required
Onsite/Remote	Onsite
Security Level	None



Warning

This equipment must be grounded. Never defeat the ground conductor or operate the equipment in the absence of a suitably installed ground conductor. Contact the appropriate electrical inspection authority or an electrician if you are uncertain that suitable grounding is available. Statement 1024

-
- Step 1** Use a wire-stripping tool to remove approximately 19 mm (0.75 inch) of the covering from the end of the grounding wire.
 - Step 2** Insert the stripped end of the grounding wire into the open-end of the grounding lug.
 - Step 3** Use the crimping tool to secure the grounding wire in two different places in the grounding lug.
 - Step 4** Locate the grounding receptacle on the side panel of the shelf ([Figure 1-14](#)).
 - Step 5** Place the grounding lug against the grounding receptacle on the side panel of the shelf.
 - Step 6** Insert one of the screws through the locking washer and through the hole in the grounding lug. Insert the screw into the threaded holes on the right side of the shelf. Ensure that the grounding lug does not interfere with other system hardware or rack equipment.
 - Step 7** Repeat [Step 6](#) with the second screw.
 - Step 8** Prepare the other end of the grounding wire and connect it to an appropriate grounding point in your site to ensure adequate earth ground for the shelf.

Figure 1-14 **Grounding the ONS 15454 ETSI**

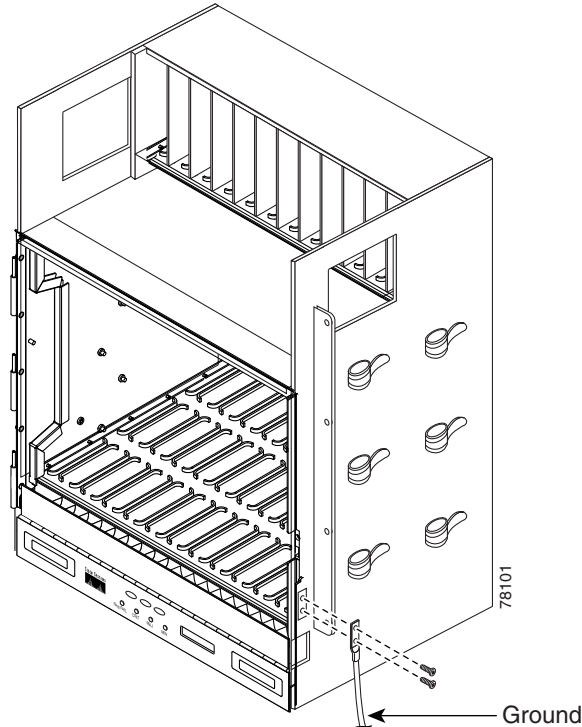

Step 9 Return to your originating procedure (NTP).

DLP-G16 Connect the Office Ground to the ONS 15454 ANSI

Purpose	This task connects ground to the ONS 15454 ANSI shelf.
Tools/Equipment	#2 Phillips screwdriver Medium slot-head screwdriver Small slot-head screwdriver Screws Power cable (from fuse and alarm panel to assembly), #10 AWG, copper conductors, 194 degrees F [90 degrees C] Ground cable #6 AWG stranded Listed pressure terminal connectors such as ring and fork types; connectors must be suitable for #10 AWG copper conductors
Prerequisite Procedures	DLP-G13 Remove the Lower Backplane Cover, page 1-27
Required/As Needed	Required
Onsite/Remote	Onsite
Security Level	None

-
- Step 1** Verify that the office ground cable (#6 AWG stranded) is connected to the top of the bay according to local site practice.
- Step 2** Attach one end of the shelf ground cable (#10 AWG) to the right side of the backplane ground nut. See [Figure 1-15](#) for the location of the ground on the backplane.



Note When terminating a frame ground, use the Kepnut provided with the ONS 15454 and tighten it to a torque specification of 31 in-lb. The Kepnut provides a frame ground connection that minimizes the possibility of loosening caused by rotation during installation and maintenance activity. The type of prevention the kep nut provides for the frame ground connection is inherently provided by the terminal block for battery and battery return connections.

Figure 1-15 Ground Location on the Backplane

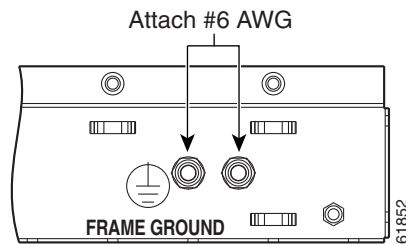

- Step 3** Attach the other end of the shelf ground cable to the bay.
- Step 4** Return to your originating procedure (NTP).
-

DLP-G17 Connect Office Power to the ONS 15454 ETSI

Purpose	This task connects power to the ONS 15454 ETSI shelf.
Tools/Equipment	<p>#2 Phillips screwdriver</p> <p>Medium slot-head screwdriver</p> <p>Small slot-head screwdriver</p> <p>Wire wrapper</p> <p>Wire cutters</p> <p>Wire strippers</p> <p>Crimp tool</p> <p>Fuse panel</p> <p>Power cable (from fuse and alarm panel to assembly), 5.26-mm² (#10 AWG), copper conductors, 194 degrees F [90 degrees C]</p> <p>Ground cable 13.3-mm² (#6 AWG) stranded</p> <p>Listed pressure terminal connectors such as ring and fork types; connectors must be suitable for 5.26-mm² (#10 AWG) copper conductors</p>
Prerequisite Procedures	DLP-G15 Connect the Office Ground to the ONS 15454 ETSI, page 1-32
Required/As Needed	Required
Onsite/Remote	Onsite
Security Level	None



Warning

When installing or replacing the unit, the ground connection must always be made first and disconnected last. Statement 1046



Caution

Do not apply power to the ONS 15454 ETSI until you complete all installation steps and check the continuity of the -48 VDC battery and battery return.



Note

No more than 2 m (7 ft) of the power supply cable should be exposed between the equipment and the fiber-storage tray.



Note

Only use listed compression-type connectors when terminating the battery, battery return, and ground conductors. Connectors must be suitable for copper conductors.



Caution

When terminating power, return, and frame ground, do not use soldering lug connectors, screwless (push-in) connectors, quick-connect connectors, or other friction-fit connectors.

**Note**

If the system loses power or if both TCC2/TCC2P cards are reset, you must reset the ONS 15454 ETSI clock. After powering down, the date defaults to January 1, 1970, 00:04:15. To reset the clock, see the [“NTP-G24 Set Up Name, Date, Time, and Contact Information” procedure on page 3-10](#).

- Step 1** Verify that the MIC-A/P FMEC is installed in Slot 23 and the MIC-C/T/P FMEC is installed in Slot 24 of the EFCA.
- Step 2** Attach the connector on the end of the power cable to the power FMEC.
- Step 3** Tighten the screws of the connector on the power cable.
- Step 4** Connect the power cable to the fuse panel or power source. Use the pin connections in [Table 1-1](#). The conductor (green with yellow stripes) is used for secondary grounding such as grounding to the rack.

Table 1-1 Pin Connection of the Power FMECs

Pin	Function	Cable Color
A1	Battery return	Black
A2	-48 V battery	Red
A3	Ground	Green with yellow stripes

- Step 5** Return to your originating procedure (NTP).

DLP-G18 Connect Office Power to the ONS 15454 ANSI

Purpose	This task connects power to the ONS 15454 ANSI shelf.
Tools/Equipment	<ul style="list-style-type: none"> #2 Phillips screwdriver Medium slot-head screwdriver Small slot-head screwdriver Wire wrapper Wire cutters Wire strippers Crimp tool Fuse panel Power cable (from fuse and alarm panel to assembly), #10 AWG, copper conductors, 194 degrees F [90 degrees C]) Ground cable #6 AWG stranded Listed pressure terminal connectors such as ring and fork types; connectors must be suitable for #10 AWG copper conductors
Prerequisite Procedures	DLP-G16 Connect the Office Ground to the ONS 15454 ANSI, page 1-33
Required/As Needed	Required

Onsite/Remote Onsite
 Security Level None



Warning

When installing or replacing the unit, the ground connection must always be made first and disconnected last. Statement 1046



Note

The battery return connection is treated as DC-1, as defined in Telcordia GR-1089-CORE Issue 3.



Note

If the system loses power or both TCC2/TCC2P cards are reset and the system is not provisioned to get the time from a Network Time Protocol/Simple Network Time Protocol (NTP/SNTP) server, you must reset the ONS 15454 clock. After powering down, the date defaults to January 1, 1970, 00:04:15. To reset the clock, see the “[NTP-G24 Set Up Name, Date, Time, and Contact Information](#)” procedure on [page 3-10](#). If you are using the TCC2/TCC2P cards, the system clock will run for up to three hours. In this case, no action would be required.

- Step 1** Connect the office power according to the fuse panel engineering specifications.
- Step 2** Measure and cut the cables as needed to reach the ONS 15454 from the fuse panel. [Figure 1-16](#) shows the ONS 15454 power terminals.
- Step 3** Dress the power according to local site practice.

Figure 1-16 Cisco ONS 15454 Power Terminals

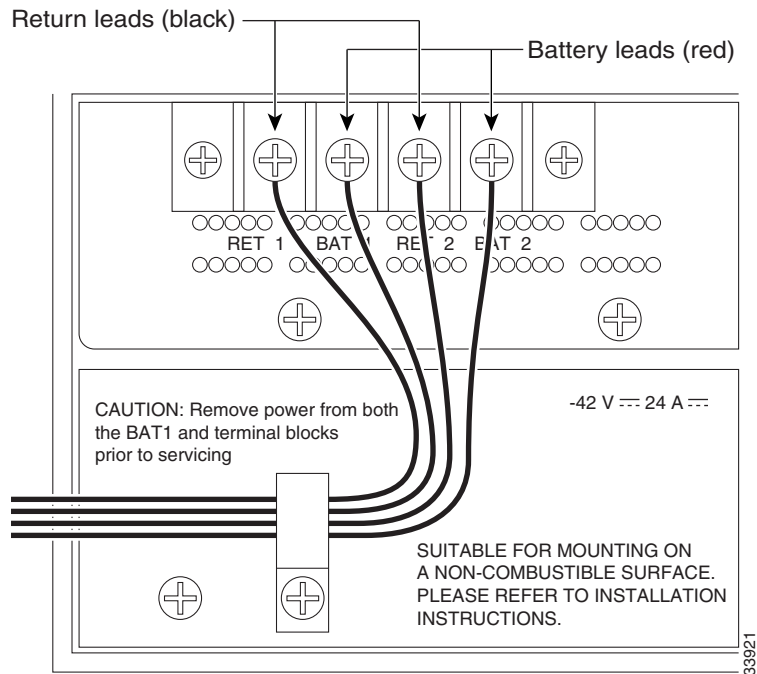

- Step 4** Remove or loosen the #8 power terminal screws on the ONS 15454. To avoid confusion, label the cables connected to the BAT1/RET1 (A) power terminals as 1 and the cables connected to the BAT2/RET2 (B) power terminals as 2.



Note Use only pressure terminal connectors, such as ring and fork types, when terminating the battery, battery return, and frame ground conductors.



Caution Before you make any crimp connections, coat all bare conductors (battery, battery return, and frame ground) with an appropriate antioxidant compound. Bring all unplated connectors, braided strap, and bus bars to a bright finish, then coat with an antioxidant before you connect them. You do not need to prepare tinned, solder-plated, or silver-plated connectors and other plated connection surfaces, but always keep them clean and free of contaminants.



Caution When terminating power, return, and frame ground, do not use soldering lug, screwless (push-in) connectors, quick-connect, or other friction-fit connectors.

Step 5 Strip 1/2 inch (12.7 mm) of insulation from all power cables that you will use.

Step 6 Crimp the lugs onto the ends of all power leads.



Note When terminating battery and battery return connections as shown in [Figure 1-16](#), follow a torque specification of 10 in-lb.

Step 7 Terminate the return 1 lead to the RET1 backplane terminal. Use oxidation-prevention grease to keep the connections noncorrosive.

Step 8 Terminate the negative 1 lead to the negative BAT1 backplane power terminal. Use oxidation prevention grease to keep connections noncorrosive.

Step 9 If you use redundant power leads, terminate the return 2 lead to the positive RET2 terminal on the ONS 15454. Terminate the negative 2 lead to the negative BAT2 terminal on the ONS 15454. Use oxidation-preventative grease to keep connections noncorrosive.

Step 10 Route the cables out below the power terminals using the plastic cable clamp, as shown in [Figure 1-16 on page 1-37](#).

Step 11 Return to your originating procedure (NTP).



DLP-G19 Turn On and Verify Office Power

Purpose	This task measures the power to verify correct power and returns for the ONS 15454 shelf.
Tools/Equipment	Voltmeter
Prerequisite Procedures	DLP-G15 Connect the Office Ground to the ONS 15454 ETSI, page 1-32 DLP-G17 Connect Office Power to the ONS 15454 ETSI, page 1-35 DLP-G16 Connect the Office Ground to the ONS 15454 ANSI, page 1-33 DLP-G18 Connect Office Power to the ONS 15454 ANSI, page 1-36
Required/As Needed	Required
Onsite/Remote	Onsite
Security Level	None



Caution

Do not apply power to the shelf assembly until you complete all installation steps.

- Step 1** Using a voltmeter, verify the office battery and ground at the following points on the fuse and alarm panel:
- a. To verify the power, place the black test lead of the voltmeter to the frame ground. Place the red test lead on the A-side connection and verify that it is between -40.5 VDC and -57 VDC. Place the red test lead on the B-side connection and verify that it is between -40.5 VDC and -57 VDC.
-  **Note** The voltages -40.5 VDC and -57 VDC are, respectively, the minimum and maximum voltages required to power the chassis.
- b. To verify the ground, place the black test lead of the voltmeter to the frame ground. Place the red test lead on the A-side return ground and verify that no voltage is present. Place the red test lead on the B-side return ground and verify that no voltage is present.
- Step 2** Insert the fuse into the fuse position according to site practice. The fuse rating must not exceed 30A.
- Step 3** At the bottom rear of the shelf assembly, remove the cover panel to access the power connections.
- Step 4** Using a voltmeter, verify the ONS 15454 shelf for -48 VDC battery and ground:
- a. To verify the A-side of the shelf, place the black lead of the voltmeter to the frame ground. Place the red test lead to the BAT1 (A-side battery connection) red cable. Verify that it reads between -40.5 VDC and -57 VDC. Then place the red test lead of the voltmeter to the RET1 (A-side return ground) black cable and verify that no voltage is present.
-  **Note** The voltages -40.5 VDC and -57 VDC are, respectively, the minimum and maximum voltages required to power the chassis.
- b. To verify the B-side of the shelf, place the black test lead of the voltmeter to the frame ground. Place the red test lead to the BAT2 (B-side battery connection) red cable. Verify that it reads between -40.5 VDC and -57 VDC. Then place the red test lead of the voltmeter to the RET2 (B-side return ground) black cable and verify that no voltage is present.

Step 5 Return to your originating procedure (NTP).

NTP-G8 Install the Fan-Tray Assembly

Purpose	This procedure installs the fan-tray assembly.
Tools/Equipment	#2 Phillips screwdriver Medium slot-head screwdriver Small slot-head screwdriver
Prerequisite Procedures	NTP-G3 Open and Remove the Front Door, page 1-20 NTP-G7 Install the Power and Ground, page 1-30
Required/As Needed	Required
Onsite/Remote	Onsite
Security Level	None



Caution

Do not operate an ONS 15454 without a fan-tray air filter. A fan-tray air filter is mandatory, except for ONS 15454 ANSI applications in an outside plant cabinet.



Caution

You must place the edge of the air filter flush against the front of the fan-tray assembly compartment when installing the fan tray on top of the filter. Failure to do so could result in damage to the filter, the fan tray, or both.



Caution

Do not force a fan-tray assembly into place. Doing so can damage the connectors on the fan tray and/or the connectors on the back panel of the shelf assembly.



Note

Error messages appear on the TCC2/TCC2P card, the fan-tray LED, and in Cisco Transport Controller (CTC) when the fan-tray assembly is removed from the shelf or when one fan is not working.



Note

If you are installing the ONS 15454 in an outside plant cabinet, remove the air filter to provide maximum cooling capabilities and to comply with Telcordia GR-487-CORE.



Note

To install the fan-tray assembly, it is not necessary to move any of the fiber-storage facilities.

Step 1 Install the air filter. The air filter can be installed internally between the fan tray and shelf assembly, or externally by mounting the air filter bracket on the bottom of the shelf assembly. Slide the air filter into the bracket.

Step 2 Install the fan-tray assembly. [Figure 1-17](#) shows the fan-tray assembly location on the ONS 15454 ETSI. [Figure 1-18](#) shows the fan-tray assembly location on the ONS 15454 ANSI.

- For the ONS 15454 ETSI shelf, press and hold the locks on the outer edges as you slide the fan-tray assembly into the shelf assembly.
- For the ONS 15454 ANSI shelf, slide the fan-tray assembly into the shelf.

The electrical plug at the rear of the tray should plug into the corresponding receptacle on the assembly.

**Caution**

Do not force a fan-tray assembly into place. This can damage the connectors on the fan-tray assembly and/or the connectors on the back panel of the shelf assembly.

Figure 1-17 *Installing the Fan-Tray Assembly on the ONS 15454 ETSI*

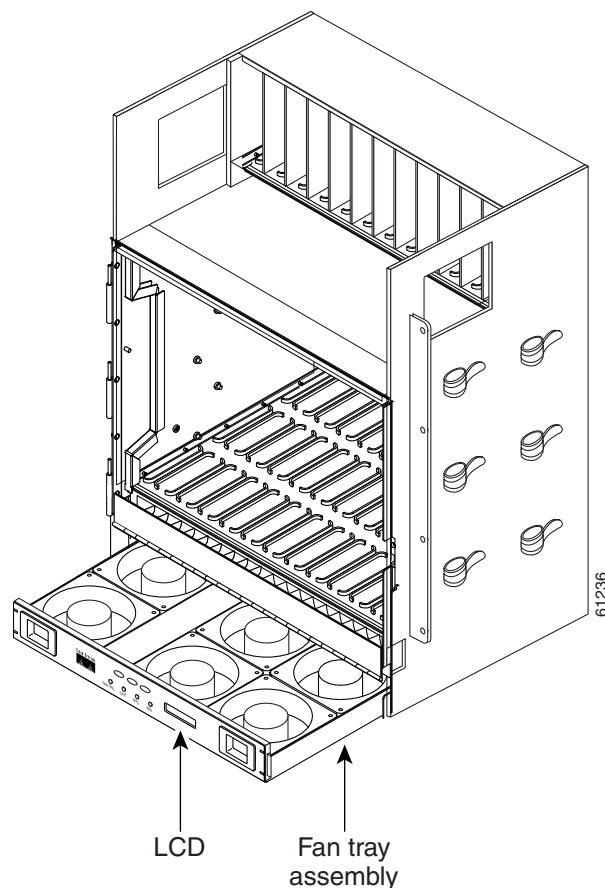
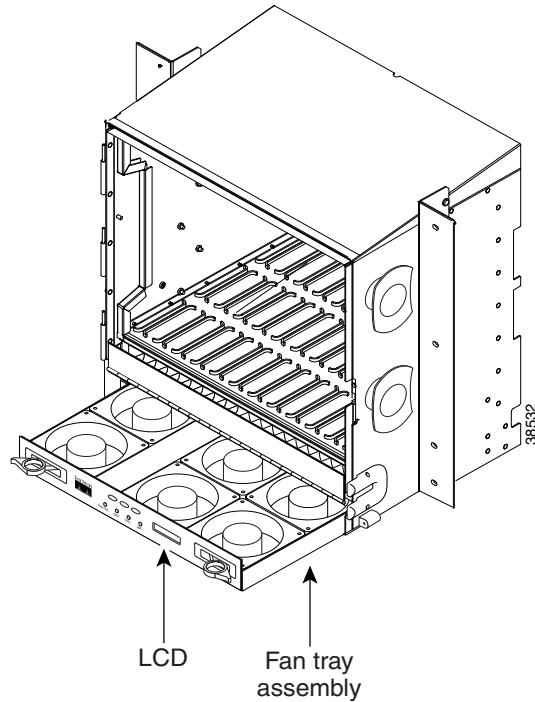

Figure 1-18 Installing the Fan-Tray Assembly on the ONS 15454 ANSI



- Step 3** To verify that the tray has plugged into the assembly, look at the fan tray and listen to determine that the fans are running.
- Step 4** If you want to install an alarm expansion panel on the ONS 15454 ANSI shelf, continue with the [“NTP-G9 Install the Alarm Expansion Panel \(ANSI Only\)”](#) procedure on page 1-43. Otherwise, continue with the [“NTP-G10 Attach Wires to Alarm, Timing, LAN, and Craft Pin Connections”](#) procedure on page 1-46.

Stop. You have completed this procedure.

NTP-G9 Install the Alarm Expansion Panel (ANSI Only)

Purpose	This procedure installs an AEP onto the 15454-SA-ANSI or 15454-SA-HD shelf backplane. The AEP provides alarm contacts (32 inputs, 16 outputs) in addition to the 16 provided by the AIC-I card. Typically, the AEP is preinstalled when ordered with the ONS 15454; however, the AEP can be ordered separately. The AIC-I card must be installed before you can provision the alarm contacts enabled by the AEP.
Tools/Equipment	#2 Phillips screwdriver Medium slot-head screwdriver Small slot-head screwdriver Wire wrapper 6-pair #29 AWG double-shielded cable Standoffs (4)
Prerequisite Procedures	DLP-G13 Remove the Lower Backplane Cover, page 1-27
Required/As Needed	As needed
Onsite/Remote	Onsite
Security Level	None

**Note**

The AIC-I card provides direct alarm contacts (external alarm inputs and external control outputs). In the ANSI shelf, these AIC-I alarm contacts are routed through the backplane to wire-wrap pins accessible from the back of the shelf. When you install an AEP, the direct AIC-I alarm contacts cannot be used. Only the AEP alarm contacts can be used.

-
- Step 1** Remove the two backplane screws. Replace the two screws with standoffs. Insert the longer standoff on the left, and the shorter standoff on the right ([Figure 1-19](#)).

Figure 1-19 Replace Backplane Screws with Standoffs

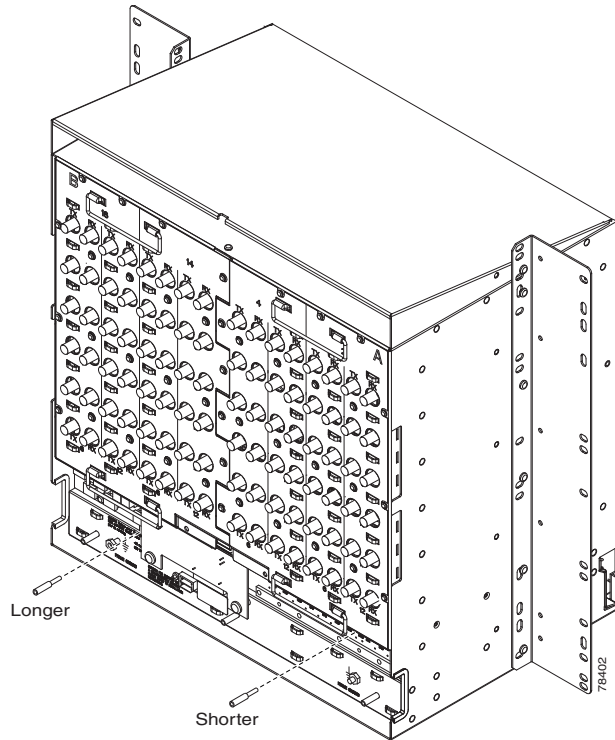

- Step 2** Attach the remaining two standoffs on either side of the backplane ([Figure 1-20](#)).
- Step 3** Position the AEP board over the standoffs.

Figure 1-20 *Installing Standoffs and the AEP*

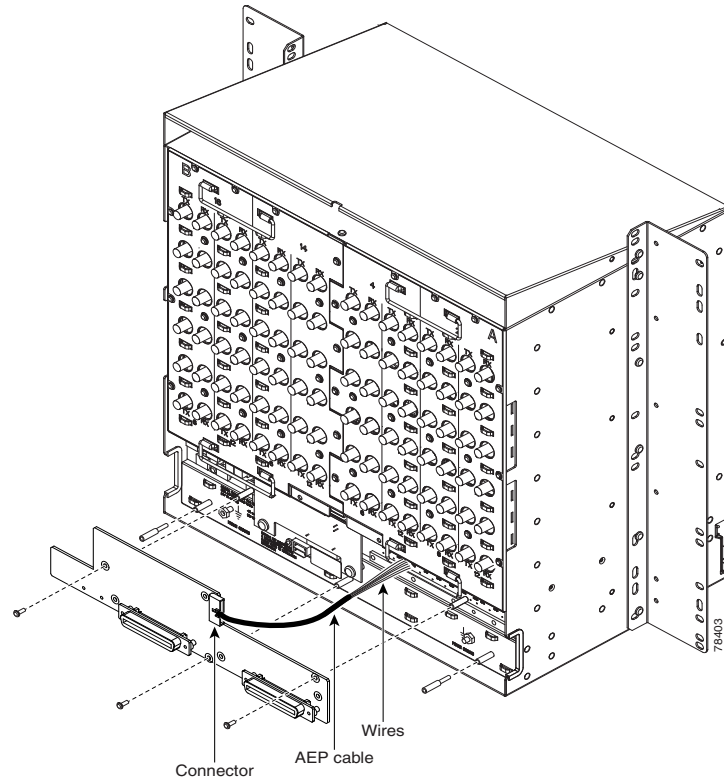

Step 4 Insert and tighten three screws to secure the AEP to the backplane.

Step 5 Connect the AEP cable to the backplane and AEP:

- a. Connect the 10 colored wires to the wire-wrap pins on the backplane. [Figure 1-21](#) shows where the cable wires are connected. [Table 1-2](#) shows AEP and AIC-I signals that each wire carries
- b. Plug the other end of the AEP cable into AEP connector port. The brown pin is on the top.

Figure 1-21 *AEP Wire-Wrap Connections to Backplane Pins*

Table 1-2 Pin Assignments for the AEP

AEP Cable Wire	Backplane Pin	AIC-I Signal	AEP Signal
Black	A1	GND	AEP_GND
White	A2	AE_+5	AEP_+5
Slate	A3	VBAT-	VBAT-
Violet	A4	VB+	VB+
Blue	A5	AE_CLK_P	AE_CLK_P
Green	A6	AE_CLK_N	AE_CLK_N
Yellow	A7	AE_DIN_P	AE_DOUT_P
Orange	A8	AE_DIN_N	AE_DOUT_N
Red	A9	AE_DOUT_P	AE_DIN_P
Brown	A10	AE_DOUT_N	AE_DIN_N

Step 6 Continue with the “NTP-G10 Attach Wires to Alarm, Timing, LAN, and Craft Pin Connections” procedure on page 1-46.

Stop. You have completed this procedure.

NTP-G10 Attach Wires to Alarm, Timing, LAN, and Craft Pin Connections

Purpose	This procedure installs alarm, timing, LAN, and craft wires on the ONS 15454 shelf. These wires are attached to the mechanical interface card (MIC) FMECs on the ETSI shelf and are attached to the backplane on the ANSI shelf.
Tools/Equipment	Connectors according to function Twisted #22 or #24 AWG (0.51 mm ² or 0.64 mm ²) shielded wires for LAN or craft 75-ohm coaxial cable with 1.0/2.3 miniature coax connector 0.51 mm ² or 0.64 mm ² (#22 or #24 AWG) alarm wires
Prerequisite Procedures	NTP-G6 Install the MIC-A/P and MIC-T/C/P FMECs (ETSI Only) , page 1-28 NTP-G5 Remove the Backplane Covers (ANSI Only) , page 1-26
Required/As Needed	As needed
Onsite/Remote	Onsite
Security Level	None



Caution

Always use the supplied ESD wristband when working with a powered ONS 15454 ETSI. Plug the wristband cable into the ESD jack located on the lower-right outside edge of the shelf assembly.

-
- Step 1** For an ONS 15454 ETSI shelf, complete the following tasks as necessary:
- Complete the “[DLP-G20 Install Alarm Wires on the MIC-A/P \(ETSI Only\)](#)” task on page 1-47 if you want to provision external alarms and/or controls with the AIC-I card.
 - Complete the “[DLP-G21 Install Timing Wires on the MIC-C/T/P \(ETSI Only\)](#)” task on page 1-50 if you are provisioning external timing.
 - Complete the “[DLP-G22 Install LAN Wires on the MIC-C/T/P \(ETSI Only\)](#)” task on page 1-51 to create an external LAN connection. You must either install LAN wires on the MIC-C-T-P or connect a CAT-5 Ethernet cable to the LAN port on the TCC2/TCC2P card to create an external LAN connection.
- Step 2** For an ONS 15454 ANSI shelf, complete the following tasks as necessary:
- Complete the “[DLP-G23 Install Alarm Wires on the Backplane \(ANSI Only\)](#)” task on page 1-52 if you are using an AIC-I card and are not using an AEP.
 - Complete the “[DLP-G24 Install Timing Wires on the Backplane \(ANSI Only\)](#)” task on page 1-54 if you are provisioning external timing.
 - Complete the “[DLP-G25 Install LAN Wires on the Backplane \(ANSI Only\)](#)” task on page 1-55 to create an external LAN connection. You must either install LAN wires on the backplane or connect a CAT-5 Ethernet cable to the LAN port on the TCC2/TCC2P card to create an external LAN connection.
 - Complete the “[DLP-G26 Install the TL1 Craft Interface Wires \(ANSI Only\)](#)” task on page 1-56 to access Transaction Language One (TL1) using the craft interface. Craft wires or the EIA/TIA-232 port on the TCC2/TCC2P card are required to access TL1.

Stop. You have completed this procedure.

DLP-G20 Install Alarm Wires on the MIC-A/P (ETSI Only)

Purpose	This task installs alarm cables on the MIC-A/P on the ONS 15454 ETSI so that you can provision external (environmental) alarms and controls with the AIC-I card.
Tools/Equipment	DB-62 connector 0.51 mm ² or 0.64 mm ² (#22 or #24 AWG) wires
Prerequisite Procedures	NTP-G6 Install the MIC-A/P and MIC-T/C/P FMECs (ETSI Only) , page 1-28
Required/As Needed	As needed
Onsite/Remote	Onsite
Security Level	None

-
- Step 1** Using 0.51 mm² or 0.64 mm² (#22 or #24 AWG) wires, connect the alarm and control wires on the appropriate pins of the DB-62 connector. The pin connectors, signal names, and functions are listed in [Table 1-3](#).

Table 1-3 Alarm Pin Assignments

DB-62 Pin Connector	Signal Name	Function
1	ALMCUTOFF-	Alarm cutoff
2	ALMCUTOFF+	Alarm cutoff
3	ALMINP0-	Alarm input pair number 1
4	ALMINP0+	Alarm input pair number 1
5	ALMINP1-	Alarm input pair number 2
6	ALMINP1+	Alarm input pair number 2
7	ALMINP2-	Alarm input pair number 3
8	ALMINP2+	Alarm input pair number 3
9	ALMINP3-	Alarm input pair number 4
10	ALMINP3+	Alarm input pair number 4
11	EXALM0-	Extra alarm 0
12	EXALM0+	Extra alarm 0
13	FGND	Ground
14	EXALM1-	Extra alarm 1
15	EXALM1+	Extra alarm 1
16	EXALM2-	Extra alarm 2
17	EXALM2+	Extra alarm 2
18	EXALM3-	Extra alarm 3
19	EXALM3+	Extra alarm 3
20	EXALM4-	Extra alarm 4
21	EXALM4+	Extra alarm 4
22	EXALM5-	Extra alarm 5
23	EXALM5+	Extra alarm 5
24	EXALM6-	Extra alarm 6
25	EXALM6+	Extra alarm 6
26	FGND	Ground
27	EXALM7-	Extra alarm 7
28	EXALM7+	Extra alarm 7
29	EXALM8-	Extra alarm 8
30	EXALM8+	Extra alarm 8
31	EXALM9-	Extra alarm 9
32	EXALM9+	Extra alarm 9
33	EXALM10-	Extra alarm 10
34	EXALM10+	Extra alarm 10
35	EXALM11-	Extra alarm 11
36	EXALM11+	Extra alarm 11

Table 1-3 Alarm Pin Assignments (continued)

DB-62 Pin Connector	Signal Name	Function
37	ALMOUP0-	Normally open output pair number 1
38	ALMOUP0+	Normally open output pair number 1
39	FGND	Ground
40	ALMOUP1-	Normally open output pair number 2
41	ALMOUP1+	Normally open output pair number 2
42	ALMOUP2-	Normally open output pair number 3
43	ALMOUP2+	Normally open output pair number 3
44	ALMOUP3-	Normally open output pair number 4
45	ALMOUP3+	Normally open output pair number 4
46	AUDALM0-	Normally open minor audible alarm
47	AUDALM0+	Normally open minor audible alarm
48	AUDALM1-	Normally open major audible alarm
49	AUDALM1+	Normally open major audible alarm
50	AUDALM2-	Normally open critical audible alarm
51	AUDALM2+	Normally open critical audible alarm
52	FGND	Ground
53	AUDALM3-	Normally open remote audible alarm
54	AUDALM3+	Normally open remote audible alarm
55	VISALM0-	Normally open minor visible alarm
56	VISALM0+	Normally open minor visible alarm
57	VISALM1-	Normally open major visible alarm
58	VISALM1+	Normally open major visible alarm
59	VISALM2-	Normally open minor visible alarm
50	VISALM2+	Normally open minor visible alarm
61	VISALM3-	Normally open minor visible alarm
62	VISALM3+	Normally open minor visible alarm

- Step 2** Connect the other end of the alarm and control wires according to local site practice.
- Step 3** Connect the DB-62 connector to the ALARM IN/OUT connector on the MIC-A/P faceplate.
- Step 4** Tighten the screws of the connector on the alarm cable.
- Step 5** Return to your originating procedure (NTP).

DLP-G21 Install Timing Wires on the MIC-C/T/P (ETSI Only)

Purpose	This task installs the timing cables on the MIC-C/T/P FMEC.
Tools/Equipment	75-ohm coaxial cable with a 1.0/2.3 miniature coax connector on the MIC-C/T/P side
Prerequisite Procedures	NTP-G6 Install the MIC-A/P and MIC-T/C/P FMECs (ETSI Only), page 1-28
Required/As Needed	As needed
Onsite/Remote	Onsite
Security Level	None

Step 1 Using coaxial cable with 1.0/2.3 miniature coax connectors, connect the clock cable to the appropriate connector on the faceplate of the MIC-C/T/P.

Step 2 Gently push the cable with the 1.0/2.3 miniature coax connector down until the cable connector slides into the 1.0/2.3 miniature coax connector on the faceplate with a click.

The MIC-C/T/P provides 1.0/2.3 miniature coax connectors that are used for timing input and output. The top connectors are for “A” (BITS-1) timing, and the bottom connectors are for “B” (BITS-2) timing. In each case, the left connector is the input and the right connector is the output. The input connectors for timing provide a 75-ohm termination. System cables are available that can convert timing clocks from 75 ohms to 100/120 ohms. [Table 1-4](#) shows MIC-C/T/P pin assignments.

Table 1-4 MIC-C/T/P Clock Connector Pin Assignment

Pin	Function
IN 1	Input from external device
OUT 1	Output to external device
IN 2	Input from external device
OUT 2	Output to external device

A high-impedance option (> 3 kilo-ohms or greater) is possible through a jumper on the MIC-C/T/P FMEC. You can change the top timing input to high impedance by removing the jumper on P3 of the MIC-C/T/P FMEC. You can change the bottom timing input to high impedance by removing the jumper on P2 on the MIC-C/T/P FMEC.



Note Refer to ITU-T G.813 for rules about provisioning timing references.

Step 3 Connect the other end of the cable to the external source of the timing signal according to [Table 1-4](#).

Step 4 Repeat [Step 3](#) for each cable that is required.

Step 5 Return to your originating procedure (NTP).

DLP-G22 Install LAN Wires on the MIC-C/T/P (ETSI Only)

Purpose	This task installs the LAN wires on the ONS 15454 ETSI MIC-C/T/P.
Tools/Equipment	Standard CAT-5 UTP Ethernet cable (straight-through for data terminating equipment [DTE] or cross-over for data circuit-terminating equipment [DCE]) or RJ-45 connector Crimping tool for RJ-45 connector 0.51 mm ² or 0.64 mm ² (#22 or #24 AWG) wire, preferably CAT-5 UTP
Prerequisite Procedures	NTP-G6 Install the MIC-A/P and MIC-T/C/P FMECs (ETSI Only), page 1-28
Required/As Needed	As needed
Onsite/Remote	Onsite
Security Level	None



Note

Rather than using the LAN connection port on the MIC-C/T/P, you can use the LAN connection port on the TCC2/TCC2P card if preferred. Use either the MIC-C/T/P connection or the TCC2/TCC2P card connection. You cannot use the LAN connection port on the MIC-C/T/P and the LAN connection port on the TCC2/TCC2P card simultaneously; however, it is possible for you to make a direct connection from a computer to the LAN connection port on the TCC2/TCC2P card while the LAN connection port on the MIC-C/T/P is in use as long as the computer connected directly to the TCC2/TCC2P card is not connected to the same LAN.

- Step 1** Using 0.51 mm² or 0.64 mm² (#22 or #24 AWG) wire or CAT-5 UTP Ethernet cable, connect the wires to the RJ-45 connector according to [Table 1-5](#).

Table 1-5 LAN Pin Assignments

LAN	RJ-45 Pin	RJ-45 Pin	Function
LAN 1 Connecting to DCE ¹ (a hub or switch)	1	3	PNMSRX+ white/green
	2	6	PNMSRX- green
Cross-over Ethernet cable	3	1	PNMSTX white/orange
	4	4	—
	5	5	—
	6	2	PNMSTX- orange
	7	7	—
	8	8	—

Table 1-5 LAN Pin Assignments (continued)

LAN	RJ-45 Pin	RJ-45 Pin	Function
LAN 1 Connecting to DTE (a PC/workstation or router)	1	1	PNMSRX+ white/green
	2	2	PNMSRX- green
Straight-through Ethernet cable	3	3	PNMSTX+ white/orange
	4	4	—
	5	5	—
	6	6	PNMSTX- orange
	7	7	—
	8	8	—

1. The Cisco ONS 15454 ETSI is DCE.

Step 2 Return to your originating procedure (NTP).

DLP-G23 Install Alarm Wires on the Backplane (ANSI Only)

Purpose	This task installs alarm wires on the backplane so that you can provision external (environmental) alarms and controls with the AIC-I card. If you are using the AEP, do not perform this task.
Tools/Equipment	Wire wrapper #22 or #24 AWG (0.51 mm ² or 0.64 mm ²) wires 100-ohm shielded BITS clock cable pair #22 or #24 AWG (0.51 mm ² or 0.64 mm ²), twisted-pair T1-type
Prerequisite Procedures	NTP-G5 Remove the Backplane Covers (ANSI Only), page 1-26
Required/As Needed	As needed
Onsite/Remote	Onsite
Security Level	None

Step 1 Using 100-ohm shielded BITS clock cable pair #22 or #24 AWG (0.51 mm² or 0.64 mm²) twisted-pair T1-type wires, wrap the alarm wires on the appropriate wire-wrap pins according to local site practice. Ground the shield of the BITS Input cable at the BITS end. For BITS Output, wrap the ground shield of the BITS cable to the frame ground pin (FG1) located below the column of BITS pins.

[Figure 1-22](#) shows alarm pin assignments for the AIC-I in the Release 3.4 or higher ONS 15454 backplane, and [Figure 1-23](#) calls out the external alarm pins on that backplane.

Figure 1-22 Cisco ONS 15454 Backplane Pinouts (Release 3.4 or Later)

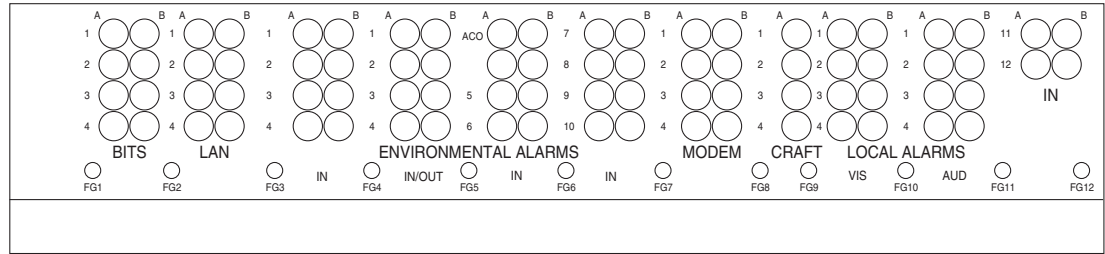

Field	Pin	Function	Field	Pin	Function
BITS	A1	BITS Output 2 negative (-)	ENVIR ALARMS IN/OUT	A1/A13	Normally open output pair number 1
	B1	BITS Output 2 positive (+)		B1/B13	
	A2	BITS Input 2 negative (-)		A2/A14	Normally open output pair number 2
	B2	BITS Input 2 positive (+)		B2/B14	
	A3	BITS Output 1 negative (-)	N/O	A3/A15	Normally open output pair number 3
	B3	BITS Output 1 positive (+)		B3/B15	
	A4	BITS Input 1 negative (-)		A4/A16	Normally open output pair number 4
	B4	BITS Input 1 positive (+)		B4/B16	
LAN	Connecting to a hub, or switch		ACO	A1	Normally open ACO pair
	A1	RJ-45 pin 6 RX-		B1	
	B1	RJ-45 pin 3 RX+	CRAFT	A1	Receive (PC pin #2)
	A2	RJ-45 pin 2 TX-		A2	Transmit (PC pin #3)
	B2	RJ-45 pin 1 TX+		A3	Ground (PC pin #5)
	Connecting to a PC/Workstation or router			A4	DTR (PC pin #4)
	A1	RJ-45 pin 2 RX-	LOCAL ALARMS AUD (Audible)	A1	Alarm output pair number 1: Remote audible alarm.
	B1	RJ-45 pin 1 RX+		B1	
A2	RJ-45 pin 6 TX-	A2		Alarm output pair number 2: Critical audible alarm.	
B2	RJ-45 pin 3 TX+	B2			
ENVIR ALARMS IN	A1	Alarm input pair number 1: Reports closure on connected wires.	N/O	A3	Alarm output pair number 3: Major audible alarm.
	B1			B3	
	A2	Alarm input pair number 2: Reports closure on connected wires.		A4	Alarm output pair number 4: Minor audible alarm.
	B2			B4	
	A3	Alarm input pair number 3: Reports closure on connected wires.	LOCAL ALARMS VIS (Visual)	A1	Alarm output pair number 1: Remote visual alarm.
	B3			B1	
	A4	Alarm input pair number 4: Reports closure on connected wires.		A2	Alarm output pair number 2: Critical visual alarm.
	B4			B2	
	A5	Alarm input pair number 5: Reports closure on connected wires.	N/O	A3	Alarm output pair number 3: Major visual alarm.
	B5			B3	
	A6	Alarm input pair number 6: Reports closure on connected wires.		A4	Alarm output pair number 4: Minor visual alarm.
	B6			B4	
A7	Alarm input pair number 7: Reports closure on connected wires.				
B7					
A8	Alarm input pair number 8: Reports closure on connected wires.				
B8					
A9	Alarm input pair number 9: Reports closure on connected wires.				
B9					
A10	Alarm input pair number 10: Reports closure on connected wires.				
B10					
A11	Alarm input pair number 11: Reports closure on connected wires.				
B11					
A12	Alarm input pair number 12: Reports closure on connected wires.				
B12					

If you are using an AIC-I card, contacts provisioned as OUT are 1-4. Contacts provisioned as IN are 13-16.

83020

Figure 1-23 Highlighted Environmental Alarms

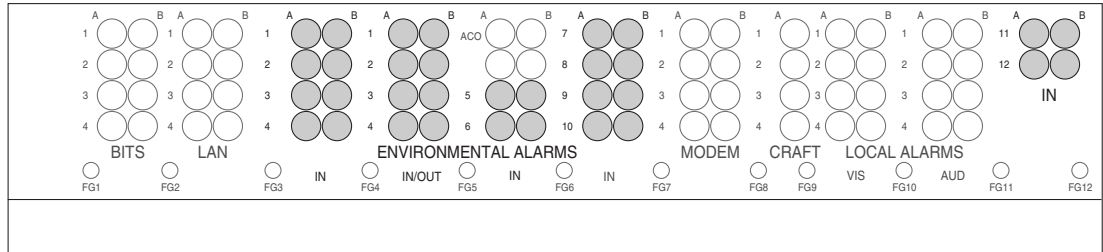

Step 2 Return to your originating procedure (NTP).

DLP-G24 Install Timing Wires on the Backplane (ANSI Only)

Purpose	This task installs the BITS timing wires on the ONS 15454 ANSI backplane.
Tools/Equipment	Wire wrapper 100-ohm shielded BITS clock cable pair #22 or #24 AWG (0.51 mm ² or 0.64 mm ²), twisted-pair T1-type
Prerequisite Procedures	NTP-G5 Remove the Backplane Covers (ANSI Only) , page 1-26
Required/As Needed	As needed
Onsite/Remote	Onsite
Security Level	None

Step 1 Using 100-ohm shielded BITS clock cable #22 or #24 AWG (0.51 mm² or 0.64 mm²), twisted-pair T1-type, wrap the clock wires on the appropriate wire-wrap pins according to local site practice.

Ground the shield of the BITS input cable at the BITS end. For BITS output, wrap the ground shield of the BITS cable to the frame ground pin (FG1) located beneath the column of BITS pins. [Table 1-6](#) lists the pin assignments for the BITS timing pin fields.

Table 1-6 External Timing Pin Assignments for BITS

BITS Pin	Tip/Ring	CTC/TL1 Name	Function
A4	ring	BITS-1	Input from BITS device 1
B4	tip	BITS-1	Input from BITS device 1
A3	ring	BITS-1	Output to external device 1
B3	tip	BITS-1	Output to external device 1
A2	ring	BITS-2	Input from BITS device 2
B2	tip	BITS-2	Input from BITS device 2
A1	ring	BITS-2	Output to external device 2
B1	tip	BITS-2	Output to external device 2



Note For more detailed information about timing, refer to the “Security Reference” chapter in the *Cisco ONS 15454 DWDM Reference Manual*. To set up system timing, see the “NTP-G53 Set Up Timing” procedure on page 6-4.

Step 2 Return to your originating procedure (NTP).

DLP-G25 Install LAN Wires on the Backplane (ANSI Only)

Purpose	This task installs the LAN wires on the ONS 15454 ANSI backplane.
Tools/Equipment	Wire wrapper #22 or #24 AWG (0.51 mm ² or 0.64 mm ²) wire, preferably CAT-5 UTP
Prerequisite Procedures	None
Required/As Needed	As needed
Onsite/Remote	Onsite
Security Level	None



Note Rather than using the LAN wires, you can use the LAN connection port on the TCC2/TCC2P if preferred. Use either the backplane connection or the TCC2/TCC2P front connection. You cannot use the LAN backplane pins and the LAN connection port on the TCC2/TCC2P simultaneously; however, it is possible for you to make a direct connection from a computer to the LAN connection port on the TCC2/TCC2P while the LAN backplane pins are in use as long as the computer that is connected directly to the TCC2/TCC2P is not connected to the same LAN.

Step 1 Using #22 or #24 AWG (0.51 mm² or 0.64 mm²) wire or CAT-5 UTP Ethernet cable, wrap the wires on the appropriate wire-wrap pins according to local site practice.



Caution Cross talk might result if both receive (Rx) and transmit (Tx) pins connect on the same twisted pair of wires from the CAT-5 cable. The two Tx pins need to be on one twisted pair, and the two Rx pins need to be on another twisted pair.

A frame ground pin is located beneath each pin field (FG2 for the LAN pin field). Wrap the ground shield of the LAN interface cable to the frame ground pin. [Table 1-7](#) shows the LAN pin assignments.

Table 1-7 LAN Pin Assignments for the ONS 15454 ANSI Shelf

Pin Field	Backplane Pins	RJ-45 Pins	Function/Color
LAN 1 Connecting to data circuit-terminating equipment (DCE) (a hub or switch); the ONS 15454 is a DCE	B2	1	TX+ white/green
	A2	2	TX- green
	B1	3	RX+ white/orange
	A1	6	RX- orange

Table 1-7 LAN Pin Assignments for the ONS 15454 ANSI Shelf

Pin Field	Backplane Pins	RJ-45 Pins	Function/Color
LAN 1 Connecting to data terminal equipment (DTE) (a PC/workstation or router)	B1	1	RX+ white/green
	A1	2	RX- green
	B2	3	TX+ white/orange
	A2	6	TX- orange



Note The TCC2/TCC2P does not support Ethernet polarity detection. If your Ethernet connection has incorrect polarity (this can only occur with cables that have the receive wire pairs flipped), a Lan Connection Polarity Reversed condition (LAN-POL-REV) is raised. This condition usually occurs during an upgrade or initial node deployment. To correct the situation, ensure that your Ethernet cable has the correct mapping of the wire-wrap pins.

Step 2 Return to your originating procedure (NTP).

DLP-G26 Install the TL1 Craft Interface Wires (ANSI Only)

Purpose	This task installs the TL1 craft interface on the ONS 15454 ANSI shelf using the craft backplane pins. You can also use a LAN cable connected to the TCC2/TCC2P EIA/TIA-232 port to access a TL1 craft interface.
Tools/Equipment	Wire wrapper #22 or #24 AWG (0.51 mm ² or 0.64 mm ²) alarm wires
Prerequisite Procedures	NTP-G5 Remove the Backplane Covers (ANSI Only), page 1-26
Required/As Needed	As needed
Onsite/Remote	Onsite
Security Level	None



Note Rather than using the craft pins, you can use a LAN cable connected to the TCC2/TCC2P EIA/TIA-232 port to access a TL1 craft interface.

Step 1 Using #22 or #24 AWG (0.51 mm² or 0.64 mm²) wire, wrap the craft interface wires on the appropriate wire-wrap pins according to local site practice.

Step 2 Wrap the ground shield of the craft interface cable to the frame-ground pin.

Wrap the ground wire of your computer cable to pin A3 on the craft pin field. [Table 1-8](#) shows the pin assignments for the CRAFT pin field.



Note You cannot use the craft backplane pins and the EIA/TIA-232 port on the TCC2/TCC2P card simultaneously. Using a combination prevents access to the node or causes a loss in connectivity.

Table 1-8 Craft Interface Pin Assignments

Pin Field	Contact	Function
Craft	A1	Receive
	A2	Transmit
	A3	Ground
	A4	DTR

Step 3 Return to your originating procedure (NTP).

NTP-G11 Install an External Wire-Wrap Panel on the AEP (ANSI Only)

Purpose	This procedure connects an external wire-wrap panel to the ONS 15454 ANSI AEP to provide the physical alarm contacts for the AEP.
Tools/Equipment	External wire-wrap panel
Prerequisite Procedures	NTP-G9 Install the Alarm Expansion Panel (ANSI Only) , page 1-43
Required/As Needed	As needed
Onsite/Remote	Onsite
Security Level	None

Step 1 Position the lower cover over the AEP. Make sure that the AEP AMP Champ connectors protrude through the cutouts in the lower cover ([Figure 1-24](#)).

Figure 1-24 Installing the AEP Cover

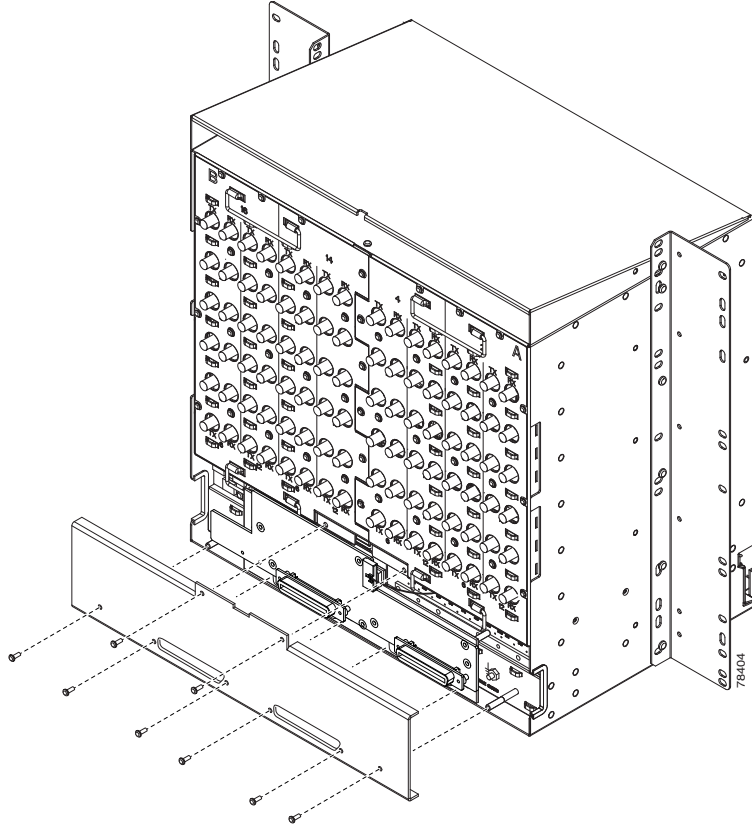

- Step 2** Insert and tighten the eight screws to secure the AEP cover to the AEP.
- Step 3** Connect the cables from the external wire-wrap panel to the AMP Champ connectors on the AEP. [Table 1-9](#) lists the alarm input pin assignments.

Table 1-9 Alarm Input Pin Assignments

AMP Champ Pin	Signal Name	AMP Champ Pin	Signal Name
1	ALARM_IN_1-	27	GND
2	GND	28	ALARM_IN_2-
3	ALARM_IN_3-	29	ALARM_IN_4-
4	ALARM_IN_5-	30	GND
5	GND	31	ALARM_IN_6-
6	ALARM_IN_7-	32	ALARM_IN_8-
7	ALARM_IN_9-	33	GND
8	GND	34	ALARM_IN_10-
9	ALARM_IN_11-	35	ALARM_IN_12-
10	ALARM_IN_13-	36	GND
11	GND	37	ALARM_IN_14-
12	ALARM_IN_15-	38	ALARM_IN_16-

Table 1-9 Alarm Input Pin Assignments (continued)

AMP Champ Pin	Signal Name	AMP Champ Pin	Signal Name
13	ALARM_IN_17-	39	GND
14	GND	40	ALARM_IN_18-
15	ALARM_IN_19-	41	ALARM_IN_20-
16	ALARM_IN_21-	42	GND
17	GND	43	ALARM_IN_22-
18	ALARM_IN_23-	44	ALARM_IN_24-
19	ALARM_IN_25-	45	GND
20	GND	46	ALARM_IN_26-
21	ALARM_IN_27-	47	ALARM_IN_28-
22	ALARM_IN_29-	48	GND
23	GND	49	ALARM_IN_30-
24	ALARM_IN_31-	50	—
25	ALARM_IN_+	51	GND1
26	ALARM_IN_0-	52	GND2

Table 1-10 lists the alarm output (external control) pin assignments.

Table 1-10 Alarm Output Pin Assignments

AMP Champ Pin	Signal Name	AMP Champ Pin	Signal Name
1	—	27	COM_0
2	COM_1	28	—
3	NO_1	29	NO_2
4	—	30	COM_2
5	COM_3	31	—
6	NO_3	32	NO_4
7	—	33	COM_4
8	COM_5	34	—
9	NO_5	35	NO_6
10	—	36	COM_6
11	COM_7	37	—
12	NO_7	38	NO_8
13	—	39	COM_8
14	COM_9	40	—
15	NO_9	41	NO_10
16	—	42	COM_10
17	COM_11	43	—

Table 1-10 Alarm Output Pin Assignments (continued)

AMP Champ Pin	Signal Name	AMP Champ Pin	Signal Name
18	NO_11	44	NO_12
19	—	45	COM_12
20	COM_13	46	—
21	NO_13	47	NO_14
22	—	48	COM_14
23	COM_15	49	—
24	NO_15	50	—
25	—	51	GND1
26	NO_0	52	GND2

Figure 1-25 illustrates the alarm input connectors.

Figure 1-25 Alarm Input Connector

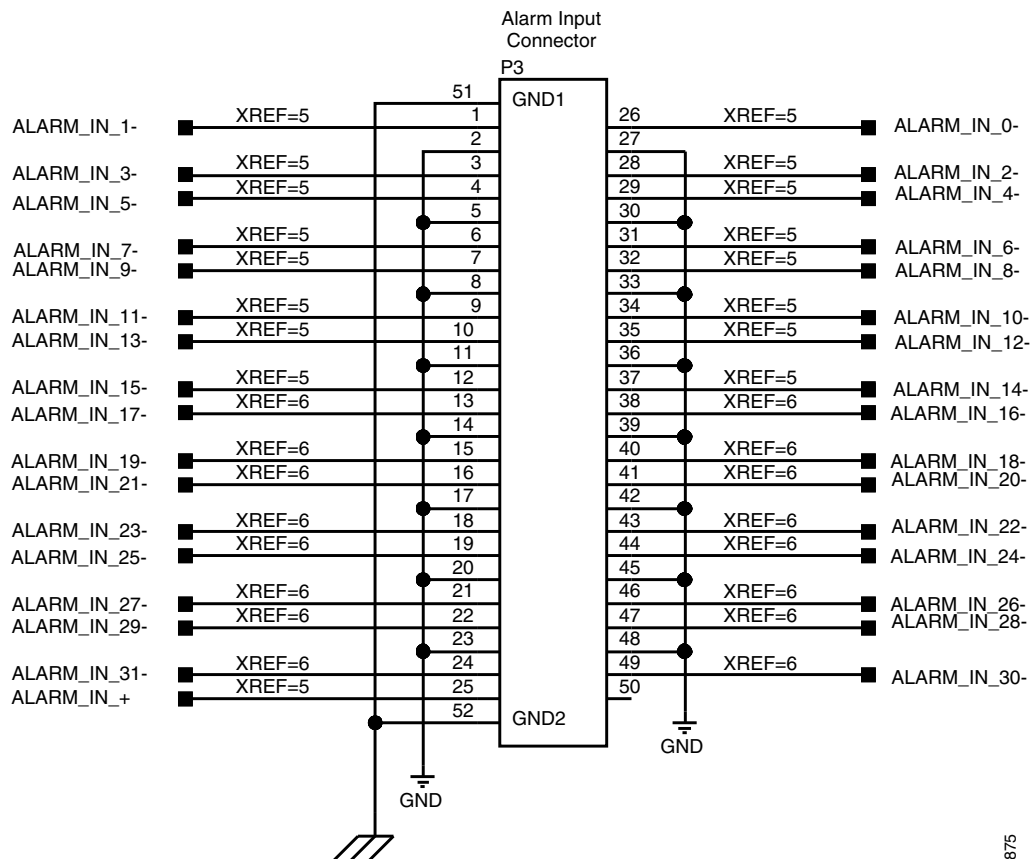
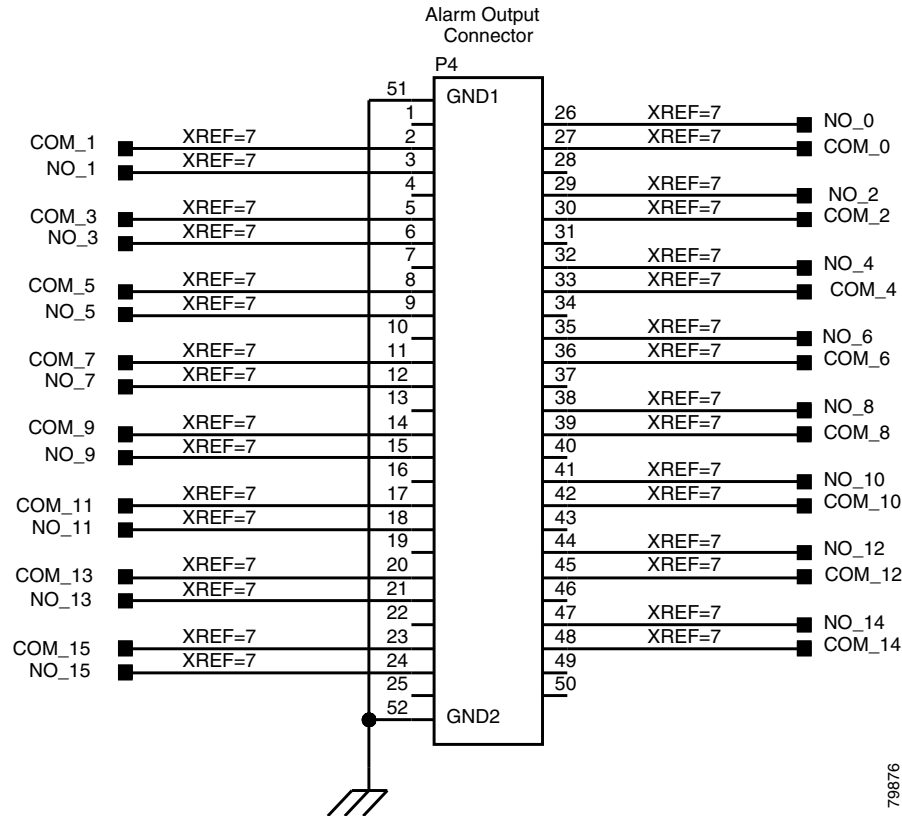

Figure 1-26 illustrates the alarm output connectors.

Figure 1-26 Alarm Output Connector



- Step 4** Continue with the “[NTP-G13 Install the Rear Cover \(ANSI Only\)](#)” procedure on page 1-62 as needed.
Stop. You have completed this procedure.

NTP-G12 Install and Close the FMEC Cover (ETSI Only)

Purpose	This procedure installs and closes the ONS 15454 ETSI FMEC cover.
Tools/Equipment	#2 Phillips screwdriver Medium slot-head screwdriver Small slot-head screwdriver
Prerequisite Procedures	NTP-G4 Open and Remove the FMEC Cover (ETSI Only) , page 1-23
Required/As Needed	Required
Onsite/Remote	Onsite
Security Level	None

- Step 1** Insert the cover carefully onto the left pin of the hinge ([Figure 1-27](#)).

- Step 2** Move the cover to the right side towards the right pin of the hinge.
- Step 3** Pull the right side of the hinge-locking spring (Figure 1-27). Push the cover onto the right pin until the spring snaps into place.

Figure 1-27 ONS 15454 ETSI FMEC Cover

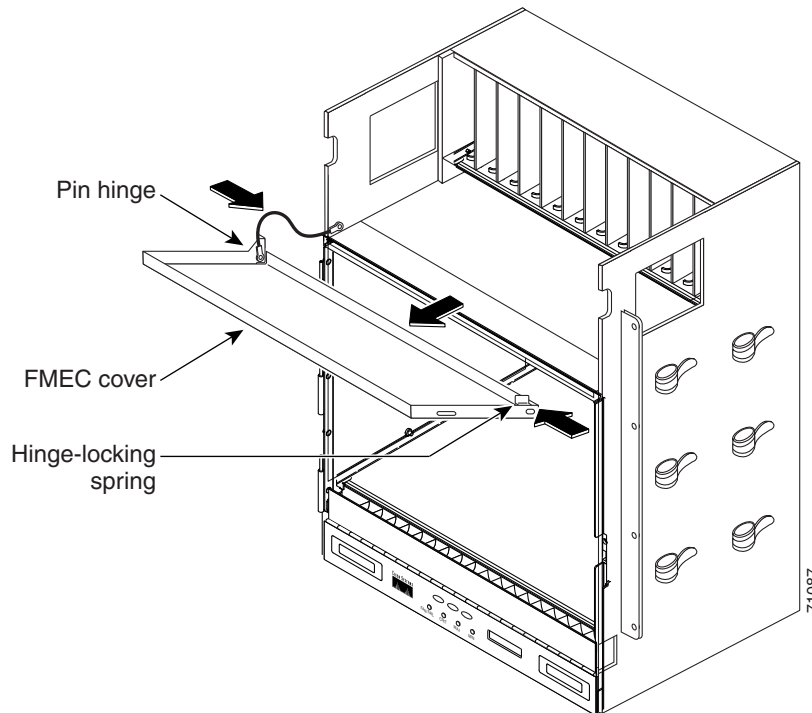

- Step 4** Attach the ground wire to the shelf.
- Step 5** Attach the washer and nut.
- Step 6** Attach the cover to the shelf using the screws on the top of the cover.
- Step 7** Continue with the “[NTP-G14 Install DWDM Equipment](#)” procedure on page 1-64.
- Stop. You have completed this procedure.**

NTP-G13 Install the Rear Cover (ANSI Only)

Purpose	The following procedure explains how to install the rear cover on an ONS 15454 ANSI shelf.
Tools/Equipment	#2 Phillips screwdriver Medium slot-head screwdriver Small slot-head screwdriver
Prerequisite Procedures	NTP-G5 Remove the Backplane Covers (ANSI Only) , page 1-26
Required/As Needed	Required

Onsite/Remote	Onsite
Security Level	None

- Step 1** Locate the three screws that run vertically along on each side of the backplane ([Figure 1-28](#)).

Figure 1-28 Backplane Attachment for the Rear Cover

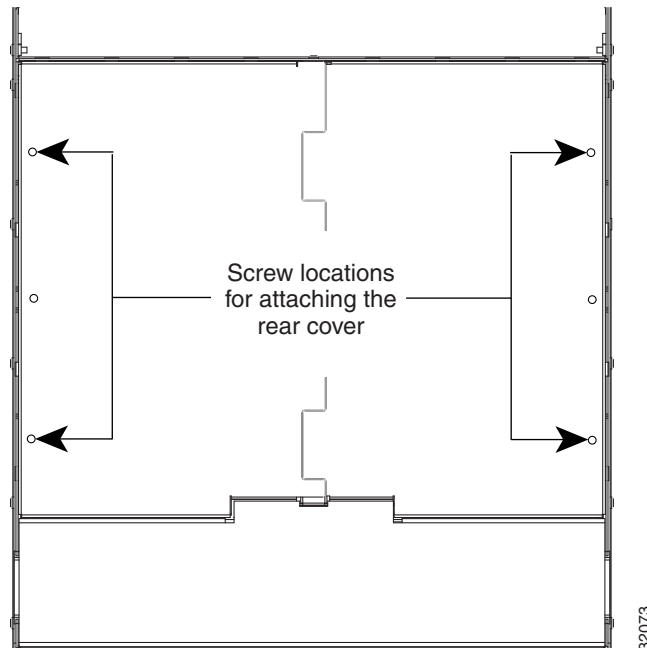

Tip Only six screws (three on each side) line up with the screw slots on the mounting brackets, making the screws easy to locate.

- Step 2** Loosen the top and bottom screws on one edge of the backplane to provide room to slide the mounting brackets into place using the U-shaped screw slots on each end.
- Step 3** Slide one of the mounting brackets into place and tighten the screws.
- Step 4** Repeat Steps 2 and 3 for the second mounting bracket.
- Step 5** Attach the cover by hanging it from the mounting screws on the back of the mounting brackets and pulling it down until it fits snugly into place.

[Figure 1-29](#) shows rear cover installation using spacers.

Figure 1-29 Installing the Rear Cover with Spacers

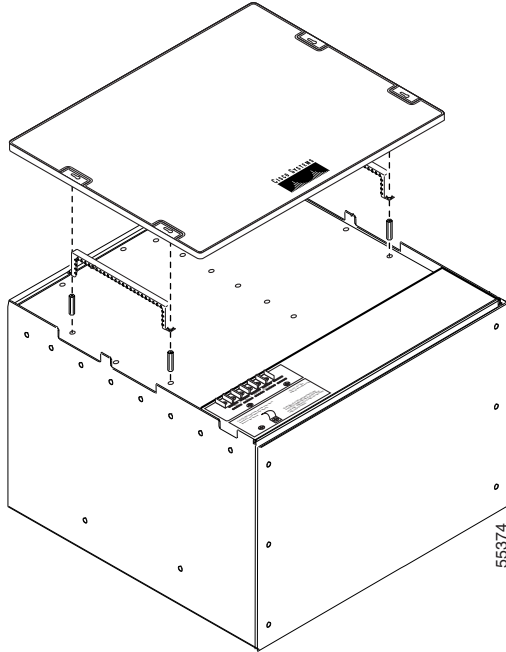

- Step 6** Continue with the “[NTP-G14 Install DWDM Equipment](#)” procedure on page 1-64.
Stop. You have completed this procedure.

NTP-G14 Install DWDM Equipment

Purpose	This procedure installs the optional DWDM assemblies.
Tools/Equipment	#2 Phillips screwdriver Crimping tool (large enough for #10 to #14 AWG) #14 AWG wire
Prerequisite Procedures	NTP-G2 Install the Shelf Assembly , page 1-8
Required/As Needed	As needed
Onsite/Remote	Onsite
Security Level	None

- Step 1** Complete the “[DLP-G27 Install the DCU Shelf Assembly](#)” task on page 1-65 as needed.
- Step 2** Complete the “[DLP-G28 Install the Fiber Patch-Panel Tray](#)” task on page 1-66 as needed.
- Step 3** Complete the “[DLP-G29 Install the Fiber-Storage Tray](#)” task on page 1-66 as needed.
- Step 4** Complete the “[DLP-G371 Install the Ethernet Adapter Panel](#)” task on page 1-67 as needed.
- Step 5** Complete the “[DLP-G351 Install the Y-Cable Module Tray](#)” task on page 1-67 as needed.
- Step 6** Complete the “[DLP-G30 Install the FlexLayer Shelf](#)” task on page 1-68 as needed.



Note Procedures for installing FlexLayer hardware in this chapter require that you have a network plan calculated for your DWDM network with Cisco MetroPlanner, Release 7.0. Cisco MetroPlanner is a DWDM planning tool that is available your Cisco account representative. Cisco MetroPlanner prepares a shelf plan for each network node and calculates the power and attenuation levels for the DWDM cards installed in the node. For information about Cisco MetroPlanner, refer to the *Cisco MetroPlanner DWDM Operations Guide*, Release 7.0.

- Step 7** Complete the “[DLP-G31 Install the FlexLayer Modules](#)” task on page 1-69 as needed.
- Step 8** Complete the “[DLP-G32 Install the Y-Cable Protection Modules in the FlexLayer Shelf](#)” task on page 1-70 as needed.
- Step 9** Complete the “[DLP-G377 Install the Y-Cable Protection Modules in the Y-Cable Module Tray](#)” task on page 1-71 as needed.

Stop. You have completed this procedure.

DLP-G27 Install the DCU Shelf Assembly

Purpose	This task installs the Dispersion Compensation Unit (DCU) chassis.
Tools/Equipment	#2 Phillips screwdriver Crimping tool #14 AWG wire and lug
Prerequisite Procedures	None
Required/As Needed	As needed
Onsite/Remote	Onsite
Security Level	None

- Step 1** The DCU chassis requires 1 rack unit (RU) in a standard 19-inch (482.6-mm) or 23-inch (584.2-mm) rack. Locate the rack mount unit (RMU) space specified in your site plan. Refer to the “Shelf Assembly Hardware” chapter in the *Cisco ONS 15454 DWDM Reference Manual* for common site layout plans.
- Step 2** Two sets of mounting brackets are included with the DCU mounting kit, one set each for 19-inch (482.6-mm) or 23-inch (584.2-mm) racks. Verify that your chassis is equipped with the correct set of brackets for your rack. Change the brackets as required.
- Step 3** Align the chassis with the rack mounting screw holes; one at a time, insert and tighten the four screws.
- Step 4** Connect a frame ground to the ground terminal provided on either side of the chassis. Use minimum #14 AWG wire.
- Step 5** Return to your originating procedure (NTP).

DLP-G28 Install the Fiber Patch-Panel Tray

Purpose	This task installs the fiber patch-panel tray. Install the appropriate L-band or C-band patch-panel tray. The sticker on the front of the tray indicates for which band the tray is used.
Tools/Equipment	#2 Phillips screwdriver
Prerequisite Procedures	None
Required/As Needed	As needed
Onsite/Remote	Onsite
Security Level	None

Step 1 The fiber patch-panel tray requires 1 to 2 RUs of space, depending on whether you are using the standard or deep patch-panel tray, in a standard 19-inch (482.6-mm) or 23-inch (584.2-mm) rack. (The standard tray requires 1 RU, and the deep tray requires 2 RUs.) Locate the RMU space specified in your site plan. Refer to the “Shelf Assembly Hardware” chapter in the *Cisco ONS 15454 DWDM Reference Manual* for common site configurations.

Step 2 Verify that the mounting brackets attached to the unit are correct for your rack size. Complete “[DLP-G3 Reverse the Mounting Bracket to Fit a 19-inch \(482.6-mm\) Rack \(ANSI Only\)](#)” task on page 1-10 as required.

Step 3 Align the tray chassis with the rack mounting screw holes, then insert and tighten the four screws.



Note Each ROADM node requires two fiber patch-panel trays.

Step 4 Return to your originating procedure (NTP).

DLP-G29 Install the Fiber-Storage Tray

Purpose	This task installs the fiber-storage tray. The fiber-storage tray stores slack fiber-optic cable.
Tools/Equipment	#2 Phillips screwdriver
Prerequisite Procedures	None
Required/As Needed	As needed
Onsite/Remote	Onsite
Security Level	None

Step 1 The fiber-storage tray requires 1 RU in a standard 19-inch (482.6-mm) or 23-inch (584.2-mm) rack. Locate the RMU space specified in your site plan. Refer to the “Shelf Assembly Hardware” chapter in the *Cisco ONS 15454 DWDM Reference Manual* for common site configurations.

Step 2 Verify that the mounting brackets attached to the unit are correct for your rack size. Complete the “[DLP-G3 Reverse the Mounting Bracket to Fit a 19-inch \(482.6-mm\) Rack \(ANSI Only\)](#)” task on page 1-10 as required.

- Step 3** Align the chassis with the rack mounting screw holes, insert the screws (4), and tighten.
- Step 4** Return to your originating procedure (NTP).

DLP-G371 Install the Ethernet Adapter Panel

Purpose	This task installs an ethernet adapter panel (EAP) in an ANSI or ETSI equipment rack. The EAP is used in multishelf node configurations to connect the MS-ISC-100T and the TCC2/TCC2P cards in the subtending nodes. Two EAPs are required in a multishelf configuration, one for each MS-ISC-100T card.
Tools/Equipment	#2 Phillips screwdriver
Prerequisite Procedures	None
Required/As Needed	As needed
Onsite/Remote	Onsite
Security Level	None

- Step 1** The EAP requires 1 RU in a standard 19-inch (482.6-mm), 23-inch (584.2-mm)/600 mm x 600mm, or 600 mm x 300 mm rack. Locate the RMU space specified in your site plan. Refer to the “Shelf Assembly Hardware” chapter in the *Cisco ONS 15454 DWDM Reference Manual* for common ANSI and ETSI site configurations.
- Step 2** Verify that the mounting brackets attached to the unit are correct for your rack size. Complete the “[DLP-G3 Reverse the Mounting Bracket to Fit a 19-inch \(482.6-mm\) Rack \(ANSI Only\)](#)” task on [page 1-10](#) as required.
- Step 3** Align the chassis with the rack mounting screw holes, insert the screws (4), and tighten.



Caution

Any paint between the EAP mounting ears and the frame of the metal rack must be removed. The area must then be cleaned and coated with an antioxidant.

- Step 4** Repeat Steps 1 – 3 for the second EAP.
- Step 5** Return to your originating procedure (NTP).

DLP-G351 Install the Y-Cable Module Tray

Purpose	This task installs the Y-cable tray. The Y-cable tray can store up to eight Y-cable protection units.
Tools/Equipment	#2 Phillips screwdriver Y-cable module tray(s) (15454-YCBL-LC) Cisco MetroPlanner Internal Connections Report
Prerequisite Procedures	None

Required/As Needed	As needed
Onsite/Remote	Onsite
Security Level	None

-
- Step 1** The Y-cable module tray requires 1 RU in a standard 19-inch (482.6-mm) or 23-inch (584.2-mm) rack. Locate the RMU space specified in your site plan. Refer to the “Shelf Assembly Hardware” chapter in the *Cisco ONS 15454 DWDM Reference Manual* for common site configurations, and use the Cisco MetroPlanner Internal Connections Report to determine how many Y-cable modules you need to install.
- Step 2** Verify that the mounting brackets attached to the unit are correct for your rack size. Complete [“DLP-G3 Reverse the Mounting Bracket to Fit a 19-inch \(482.6-mm\) Rack \(ANSI Only\)”](#) task on page 1-10 as required.
- Step 3** Align the chassis with the rack mounting screw holes, insert the four screws, and tighten.
- Step 4** Return to your originating procedure (NTP).
-

DLP-G30 Install the FlexLayer Shelf

Purpose	This task installs the FlexLayer shelf. Perform this task if you are installing any FlexLayer modules.
Tools/Equipment	#2 Phillips screwdriver FlexLayer shelf assembly (15216-FL-SA) #14 AWG wire (minimum) for frame grounding
Prerequisite Procedures	None
Required/As Needed	As needed
Onsite/Remote	Onsite
Security Level	None

-
- Step 1** The FlexLayer shelf requires 1 RU in a standard 19-inch (482.6-mm) or 23-inch (584.2-mm) rack. Locate the RMU space specified in your site plan. Refer to the “Shelf Assembly Hardware” chapter in the *Cisco ONS 15454 DWDM Reference Manual* for typical DWDM site layout plans.
- Step 2** A set of mounting brackets are included with the FlexLayer mounting kit, one set each for 19-inch (482.6-mm) or 23-inch (584.2-mm) racks. Verify that your chassis is equipped with the correct set of brackets for your rack. Change the brackets as required.
- Step 3** Align the chassis with the rack mounting screw holes; one at a time, insert and tighten the three screws.
- Step 4** Connect a frame ground to the ground terminal provided on either side of the chassis. Use minimum #14 AWG wire.
- Step 5** Repeat this task as necessary for each FlexLayer shelf assembly you want to install.
- Step 6** Return to your originating procedure (NTP).
-

DLP-G31 Install the FlexLayer Modules

Purpose	This task installs the FlexLayer modules in the FlexLayer shelf assembly. You can only install two-channel FlexLayer modules.
Tools/Equipment	#2 Phillips screwdriver FlexLayer modules
Prerequisite Procedures	None
Required/As Needed	As needed
Onsite/Remote	Onsite
Security Level	None

- Step 1** Determine the FlexLayer modules that you want to install in the FlexLayer shelf. The FlexLayer shelf can house up to four Add/Drop FlexLayer modules or four Y-cable splitter modules. [Table 1-11](#) lists the two-channel FlexLayer modules and part numbers. Refer to the “Shelf Assembly Hardware” chapter in the *Cisco ONS 15454 DWDM Reference Manual* for more information about FlexLayer modules.

Table 1-11 ONS 15xxx FlexLayer Hardware Part Numbers

Part Number	Description
2 Channel Add/Drop FlexLayer Modules	
15216-FLB-2-31.1=	ITU-100 GHz 2 Ch, FlexMod - 1530.33 and 1531.12
15216-FLB-2-32.6=	ITU-100 GHz 2 Ch, FlexMod - 1531.90 and 1532.68
15216-FLB-2-35.0=	ITU-100 GHz 2 Ch, FlexMod - 1534.25 and 1535.04
15216-FLB-2-36.6=	ITU-100 GHz 2 Ch, FlexMod - 1535.82 and 1536.61
15216-FLB-2-38.9=	ITU-100 GHz 2 Ch, FlexMod - 1538.19 and 1538.98
15216-FLB-2-40.5=	ITU-100 GHz 2 Ch, FlexMod - 1539.77 and 1540.56
15216-FLB-2-42.9=	ITU-100 GHz 2 Ch, FlexMod - 1542.14 and 1542.94
15216-FLB-2-44.5=	ITU-100 GHz 2 Ch, FlexMod - 1543.73 and 1544.53
15216-FLB-2-46.9=	ITU-100 GHz 2 Ch, FlexMod - 1546.12 and 1546.92
15216-FLB-2-48.5=	ITU-100 GHz 2 Ch, FlexMod - 1547.72 and 1548.51
15216-FLB-2-50.9=	ITU-100 GHz 2 Ch, FlexMod - 1550.12 and 1550.92
15216-FLB-2-52.5=	ITU-100 GHz 2 Ch, FlexMod - 1551.72 and 1552.52
15216-FLB-2-54.9=	ITU-100 GHz 2 Ch, FlexMod - 1554.13 and 1554.94
15216-FLB-2-56.5=	ITU-100 GHz 2 Ch, FlexMod - 1555.75 and 1556.55
15216-FLB-2-58.9=	ITU-100 GHz 2 Ch, FlexMod - 1558.17 and 1558.98
15216-FLB-2-60.6=	ITU-100 GHz 2 Ch, FlexMod - 1559.79 and 1560.61

- Step 2** Insert the appropriate module into the FlexLayer shelf assembly.



Note FlexLayer modules are not listed in generated Cisco MetroPlanner site plans.

Step 3 Use a Phillips screwdriver to install the two accompanying screws.

Figure 1-30 shows the FlexLayer shelf assembly and how the FlexLayer modules can be installed.

Figure 1-30 ONS 15xxx FlexLayer Shelf Assembly

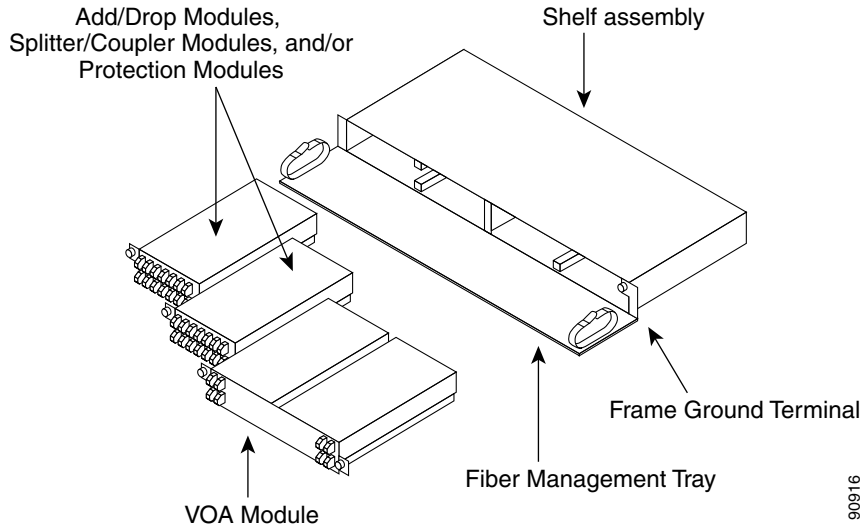

Step 4 Repeat this task as necessary for each FlexLayer module you want to install.

Step 5 Return to your originating procedure (NTP).

DLP-G32 Install the Y-Cable Protection Modules in the FlexLayer Shelf

Purpose	This task installs the Y-cable protection modules in the FlexLayer shelf assembly.
Tools/Equipment	#2 Phillips screwdriver Y-cable module(s): Multi-Mode Y-Cable Protection FlexMod: (15216-CS-MM-Y) or Single-Mode Y-Cable Protection FlexMod: (15216-CS-SM-Y), as appropriate
Prerequisite Procedures	None
Required/As Needed	As needed
Onsite/Remote	Onsite
Security Level	None

Step 1 According to the Cisco MetroPlanner Internal Connections Report, determine the Y-cable modules that you want to install in the FlexLayer shelf.

Step 2 Insert the appropriate Y-cable module into the FlexLayer shelf assembly. Use a Phillips screwdriver to install the two accompanying screws.

Step 3 Repeat Steps 1 and 2 as necessary for each Y-cable module you want to install. The FlexLayer shelf can hold up to four Y-cable modules, and the Y-cable tray can hold up to eight Y-cable modules.

- Step 4** Return to your originating procedure (NTP).

DLP-G377 Install the Y-Cable Protection Modules in the Y-Cable Module Tray

Purpose	This task installs the Y-cable protection modules in the Y-cable module tray. The Y-cable module tray can hold up to eight Y-cable modules.
Tools/Equipment	#2 Phillips screwdriver Y-cable modules: Multi-Mode Y-Cable Protection Module(s) (15454-YCM-MM-LC) or Single-Mode Y-Cable Protection Module(s) (15454-YCM-SM-LC), as appropriate Cisco MetroPlanner Internal Connections Report
Prerequisite Procedures	None
Required/As Needed	As needed
Onsite/Remote	Onsite
Security Level	None

- Step 1** According to the Cisco MetroPlanner Internal Connections Report, determine which slots you will use to install the Y-cable modules (Figure 1-31).

Figure 1-31 Y-Cable Module

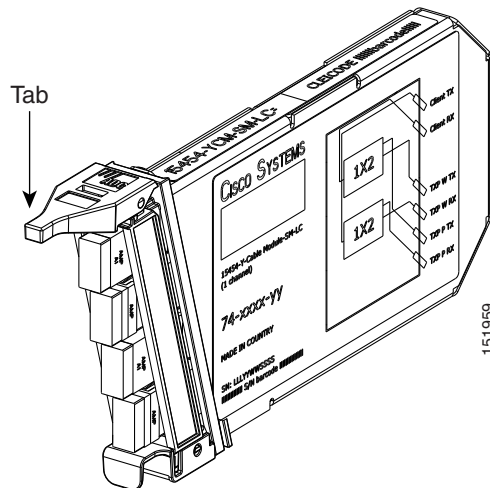

- Step 2** Open the drawer of the tray by pushing inward on the latches located at the left and right front of the tray.
- Step 3** In the tray, pull up the latches on either side of the module frame and slide the frame upward until it is fully extended.
- Step 4** Line up the first Y-cable module you want to install with the desired slot, pull the latch at the bottom of the Y-cable module to enable the Y-cable module to slide onto the guides, and slide the module down until it is fully installed in the slot.
- Step 5** Repeat Steps 1 and 4 as necessary for each Y-cable module you want to install.

Step 6 Return to your originating procedure (NTP).

NTP-G15 Install the Common Control Cards

Purpose	This procedure describes how to install the common control cards.
Tools/Equipment	Redundant TCC2/TCC2P cards (required) AIC-I card (optional) MS-ISC-100T (optional; for multishelf node configurations)
Prerequisite Procedures	NTP-G7 Install the Power and Ground, page 1-30 NTP-G14 Install DWDM Equipment, page 1-64
Required/As Needed	Required
Onsite/Remote	Onsite
Security Level	Provisioning or higher



Warning

During this procedure, wear grounding wrist straps to avoid ESD damage to the card. Do not directly touch the backplane with your hand or any metal tool, or you could shock yourself. Statement 94



Caution

Always use the supplied ESD wristband when working with a powered ONS 15454. Plug the wristband cable into the ESD jack located on the lower-right outside to edge of the shelf assembly.



Note

If protective clips are installed on the backplane connectors of the cards, remove the clips before installing the cards.



Note

If you install a card incorrectly, the FAIL LED flashes continuously.

Step 1 Complete the “[DLP-G33 Install the TCC2 or TCC2P Card](#)” task on page 1-73.



Note If you install the wrong card in a slot, see the “[NTP-G107 Permanently Remove or Remove and Replace DWDM Cards](#)” procedure on page 12-2.

Step 2 Complete the “[DLP-G34 Install the AIC-I Card](#)” task on page 1-76, if necessary.

Step 3 Complete the “[DLP-G309 Install the MS-ISC-100T Card](#)” task on page 1-77, if necessary.

Stop. You have completed this procedure.

DLP-G33 Install the TCC2 or TCC2P Card

Purpose	This task installs redundant TCC2/TCC2P cards. The first card you install in the ONS 15454 must be a TCC2/TCC2P card, and it must initialize before you install any cross-connect or traffic cards. Cross-connect cards are only required in hybrid nodes.
Tools/Equipment	Two TCC2/TCC2P cards
Prerequisite Procedures	None
Required/As Needed	Required
Onsite/Remote	Onsite
Security Level	None



Caution

Do not remove a TCC2/TCC2P card during the software transfer process, which is indicated by alternate flashing FAIL and ACT/STBY LEDs. Removing a TCC2/TCC2P during the software transfer process will corrupt the system memory.



Note

Allow each card to boot completely before installing the next card.

Step 1 Open the latches/ejectors of the first TCC2/TCC2P card that you will install.

Step 2 Use the latches/ejectors to firmly slide the card along the guide rails until the card plugs into the receptacle at the back of the slot (Slot 7 or 11).



Note

In [Step 4](#) you will be instructed to watch the LED activity (sequence) on the front of the TCC2/TCC2P card. This activity begins immediately after you close the latches in [Step 3](#).

Step 3 Verify that the card is inserted correctly and close the latches/ejectors on the card.



Note

It is possible to close the latches/ejectors when the card is not completely plugged into the back panel of the shelf assembly. Ensure that you cannot insert the card any farther.

If you insert a card into a slot provisioned for a different card, all LEDs turn off.

Step 4 As needed, go to [Step a](#) to verify the LED activity on the TCC2 card. For the TCC2P card, go to [Step b](#).

a. For the TCC2 card:

- All LEDs turn on briefly. The red FAIL LED and the yellow ACT/STBY LED turn on for about 15 seconds.
- The red FAIL LED and the green ACT/STBY LED turn on for about 40 seconds.
- The red FAIL LED blinks for about 15 seconds.
- The red FAIL LED turns on for about 15 seconds. All LEDs turn on for about 3 seconds before turning off for about 3 seconds.
- Both green PWR LEDs turn on for 10 seconds. The PWR LEDs then turn red for 2 to 3 minutes before going to steady green.

- While the PWR LEDs are red for two to three minutes, the ACT/STBY turn on.
- The boot up process is complete when the PWR LEDs turn green and the ACT/STBY remains on. (The ACT/STBY LED will be green if this is the first TCC2 card installed, and amber if this is the second TCC2 card installed.)



Note It might take up to 4 minutes for the A and B power alarms to clear.



Note Alarm LEDs might be on; disregard alarm LEDs until you are logged into CTC and can view the Alarms tab.



Note If you are logged into CTC, the SFTWDOWN alarm might appear as many as two times while the TCC2 card initializes. The alarm should clear after the card completely boots.



Note If the FAIL LED is on continuously, see the tip in [Step 8](#) about the TCC2 card automatic upload.

b. For the TCC2P card:

- All LEDs turn on briefly. The red FAIL LED, the yellow ACT/STBY LED, the green SYNC LED, and the green ACO LED turn on for about 15 seconds.
- The red FAIL LED and the green ACT/STBY LED turn on for about 30 seconds.
- The red FAIL LED blinks for about 3 seconds.
- The red FAIL LED turns on for about 15 seconds.
- The red FAIL LED blinks for about 10 seconds and then becomes solid.
- All LEDs (including the CRIT, MAJ, MIN, REM, SYNC, and ACO LEDs) blink once and turn off for about 5 seconds.
- Both green PWR LEDs turn on for 10 seconds. The PWR LEDs then turn red for 2 to 3 minutes before going to steady green. During this time, the ACT/STBY, MJ, and MN LEDs might turn on, followed by the SNYC LED briefly.
- The boot up process is complete when the PWR LEDs turn green and the yellow ACT/STBY remains on. (The ACT/STBY LED will be green if this is the first TCC2 card installed, and yellow if this is the second TCC2 card installed.)



Note It might take up to 3 minutes for the A and B power alarms to clear.



Note Alarm LEDs might be on; disregard alarm LEDs until you are logged into CTC and can view the Alarms tab.



Note If you are logged into CTC, the SFTWDOWN alarm might appear as many as two times while the TCC2P card initializes. The alarm should clear after the card completely boots.



Note If the FAIL LED is on continuously, see the tip in [Step 8](#) about the TCC2P card automatic upload.

Step 5 Verify that the ACT/STBY LED is green if this is the first powered-up TCC2/TCC2P card installed, or yellow for standby if this is the second powered-up TCC2/TCC2P. The IP address, temperature of the node, and time of day appear on the LCD. The default time and date is 12:00 AM, January 1, 1970.

Step 6 The LCD cycles through the IP address (the default is 192.1.0.2), node name, and software version. Verify that the correct software version displays on the LCD. The software text string indicates the node type (SDH or SONET) and software release. (For example: SDH 07.00-05L-20.10 indicates it is an SDH software load, Release 7.00. The numbers following the release number do not have any significance.)

Step 7 If the LCD shows the correct software version, continue with [Step 8](#). If the LCD does not show the correct software version, refer to your next level of technical support, upgrade the software, or remove the TCC2/TCC2P card and install a replacement card.

Refer to the release-specific software upgrade document to replace the software. To replace the TCC2/TCC2P card, refer to the *Cisco ONS 15454 DWDM Troubleshooting Guide*.

Step 8 Repeat Steps 1 through 7 for the redundant TCC2/TCC2P card. If both TCC2/TCC2P cards are already installed, proceed to [Step 9](#).



Tip If you install a standby TCC2/TCC2P card that has a different software version than the active TCC2/TCC2P card, the newly installed standby TCC2/TCC2P card automatically copies the software version from the active TCC2/TCC2P card. You do not need to do anything in this situation. However, the loading TCC2/TCC2P card does not boot up in the normal manner. When the standby card is first inserted, the LEDs follow most of the normal bootup sequence. However, after the red FAIL LED turns on for about 5 seconds, the FAIL LED and the ACT/STBY LED begin to flash alternately for up to 30 minutes while the new software loads onto the active TCC2/TCC2P card. After loading the new software, the upgraded TCC2/TCC2P card's LEDs repeat the appropriate bootup sequence, and the amber ACT/STBY LED turns on.



Note If you insert a card into a slot provisioned for a different card, all LEDs turn off.



Note Alarm LEDs might be on; disregard alarm LEDs until you are logged into CTC and can view the Alarms tab.

Step 9 Return to your originating procedure (NTP).

DLP-G34 Install the AIC-I Card

Purpose	This task installs the AIC-I card. The AIC-I card provides connections for external alarms and controls (environmental alarms).
Tools/Equipment	AIC-I card
Prerequisite Procedures	DLP-G33 Install the TCC2 or TCC2P Card, page 1-73
Required/As Needed	As needed
Onsite/Remote	Onsite
Security Level	None



Note When installing cards, allow each card to boot completely before installing the next card.

- Step 1** Open the latches/ejectors on the card.
- Step 2** Use the latches/ejectors to firmly slide the card along the guide rails in Slot 9 until the card plugs into the receptacle at the back of the slot.
- Step 3** Verify that the card is inserted correctly and close the latches/ejectors on the card.



Note It is possible to close the latches/ejectors when the card is not completely plugged into the backplane. Ensure that you cannot insert the card any further.

- Step 4** Verify the following:
- The red FAIL LED blinks for up to 10 seconds.



Note If the red FAIL LED does not turn on, check the power.

- The PWR A and PWR B LEDs become red, the two INPUT/OUTPUT LEDs become amber, and the ACT LED turns green for approximately 5 seconds.
- The PWR A and PWR B LEDs turn green, the INPUT/OUTPUT LEDs turn off, and the green ACT LED remains on.



Note It might take up to 3 minutes for the PWR A and PWR B LEDs to update.



Note If you insert a card into a slot provisioned for a different card, no LEDs turn on.



Note If the red FAIL LED is on continuously or the LEDs act erratically, the card is not installed properly. Remove the card and repeat Steps 1 to 4.

- Step 5** Return to your originating procedure (NTP).

DLP-G309 Install the MS-ISC-100T Card

Purpose	This task installs redundant MS-ISC-100T cards. The MS-ISC-100T card is required for a multishelf node configuration. It provides LAN redundancy on the node controller shelf. An alternative to using the MS-ISC-100T card is the Cisco Catalyst 2950, although Cisco recommends using the MS-ISC-100T. For more information on the Catalyst 2950 installation, refer to the Catalyst 2950 product documentation.
Tools/Equipment	MS-ISC-100T card (2)
Prerequisite Procedures	DLP-G33 Install the TCC2 or TCC2P Card, page 1-73
Required/As Needed	As needed
Onsite/Remote	Onsite
Security Level	None



Note When installing cards, allow each card to boot completely before installing the next card.



Note The MS-ISC-100T is not supported in a subtended shelf.

- Step 1** Open the latches/ejectors on the card.
- Step 2** Use the latches/ejectors to firmly slide the card along the guide rails in Slot 1 to 6 or 12 to 17 on the node controller shelf until the card plugs into the receptacle at the back of the slot. Cisco recommends that you install the MS-ISC-100T card in Slot 6 and Slot 12.
- Step 3** Verify that the card is inserted correctly and close the latches/ejectors on the card.



Note It is possible to close the latches/ejectors when the card is not completely plugged into the backplane. Ensure that you cannot insert the card any further.

- Step 4** Verify the LED activity:
- The red FAIL LED blinks for 35 to 45 seconds.
 - The red FAIL LED turns on for 15 to 20 seconds.
 - The red FAIL LED blinks for approximately 3 minutes.
 - The red FAIL LED turns on for approximately 6 minutes.
 - The green ACT or ACT/STBY LED turns on. The SF LED can persist until all card ports connect to their far end counterparts and a signal is present.



Note If the red FAIL LED does not turn on, check the power.



Note If you insert a card into a slot provisioned for a different card, all LEDs turn off.

- Step 5** Repeat Steps 1 through 4 for the redundant MS-ISC-100T card.

Step 6 Return to your originating procedure (NTP).

NTP-G145 Connect a Multishelf Node and Subtending Shelves to an MS-ISC-100T Card

Purpose	Use this procedure to connect a multishelf node and subtending shelves to two MS-ISC-100T cards.
Tools/Equipment	5.9 in. (0.15 m) CAT-5 LAN cable (2) 19.69 in. (0.5 m) CAT-5 LAN cable (1) Cross-over (CAT-5) LAN cables (2 for each subtending shelf) 84 in. (2.13 m) EAP cables (2)
Prerequisite Procedures	NTP-G15 Install the Common Control Cards, page 1-72 DLP-G371 Install the Ethernet Adapter Panel, page 1-67
Required/As Needed	As needed
Onsite/Remote	Onsite
Security Level	None

- Step 1** To connect the MS-ISC-100T cards to the node controller shelf and set up protection, complete the following substeps (see [Figure 1-32](#)). For more information on MS-ISC-100T card port assignments, refer to the Card Reference chapter in the *Cisco ONS 15454 DWDM Reference Manual*.
- a. Using the 5.9 in. (0.15 m) CAT-5 LAN cable, plug one connector the NC port of the MS-ISC-100T card located on the left side of the node controller shelf (Slots 1 to 6) and plug the other connector into the front panel (RJ-45 connector) of the TCC2/TCC2P card in Slot 7.
 - b. Using the 5.9 in. (0.15 m) CAT-5 LAN cable, plug one connector into the NC port of the MS-ISC-100T card located on the right side of the node controller shelf (Slots 12 to 17) and the other end into the front panel (RJ-45 connector) of the TCC2/TCC2P card in Slot 11.
 - c. Using the 19.69 in. (0.5 m) CAT-5 LAN cable, plug one connector into the PRT port of the MS-ISC-100T card located on the left side of the node controller shelf (Slots 1 to 6) and plug the other connector into the NC port of the MS-ISC-100T card located on the right side of the node controller shelf (Slots 12 to 17).
 - d. Plug the nine connectors on one end of the EAP cable into the two DCN ports and the seven subtending shelf controller (SSC) ports of the MS-ISC-100T card located on the left side of the node controller shelf (Slots 1 to 6). Plug the other end of the EAP cable into the multishelf port on the left EAP.
 - e. Plug the nine connectors on one end of the EAP cable into into the two DCN ports and the seven SSC ports of the MS-ISC-100T card in the right side of the NC shelf (Slots 12 to 17). Plug the other end of the EAP cable into the multishelf port on the right EAP.

Figure 1-32 Connecting the EAP to the Node Controller and Subtending Shelf

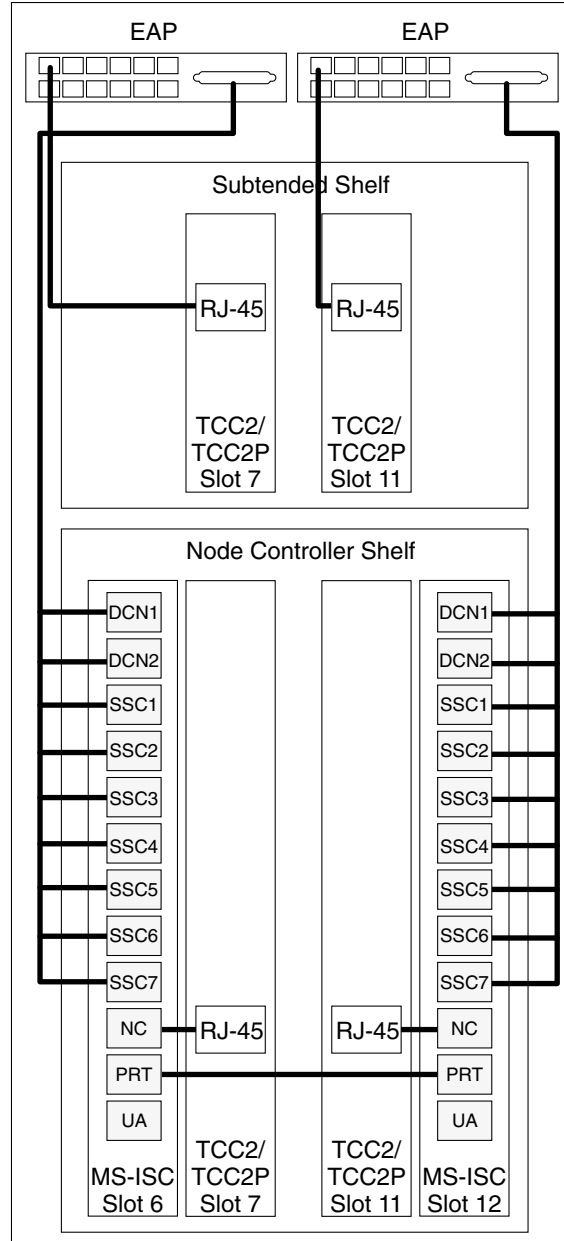

Step 2 To connect a subtending shelf to the EAP, complete the following (see [Figure 1-32](#)):

- Using a cross-over (CAT-5) LAN cable, plug one connector into the front panel (RJ-45 connector) of the subtending shelf TCC2/TCC2P card in Slot 7 and plug the other end into the SSC1 port on the left EAP.
- Using a cross-over (CAT-5) LAN cable, plug one connector into the front panel (RJ-45 connector) of the subtending shelf TCC2/TCC2P card in Slot 11 and plug the other end into the SSC1 port on the right EAP.
- Repeat Steps [a](#) and [b](#) for each subtending shelf in the multishelf configuration. Use the same SSC# port (2 through 8) on the left and right EAP for each subtending shelf.

Stop. You have completed this procedure.

NTP-G158 Connect a Multishelf Node and Subtending Shelves to a Cisco Catalyst 2950

Purpose	Use this procedure to connect a multishelf node and subtending shelves to two Cisco Catalyst 2950s.
Tools/Equipment	Two Cisco Catalyst 2950 switches must be installed in same rack as the node controller shelf; refer to the Cisco Catalyst 2950 product documentation for installation instructions. Cross-over (CAT-5) LAN cables (3, plus 2 for each subtending shelf)
Prerequisite Procedures	NTP-G15 Install the Common Control Cards, page 1-72
Required/As Needed	As needed
Onsite/Remote	Onsite
Security Level	None

-
- Step 1** Using a cross-over (CAT-5) LAN cable, plug one connector into Port 1 of the first Catalyst 2950 and plug the other connector into the front panel of the node controller TCC2/TCC2P card in Slot 7.
- Step 2** Using a cross-over (CAT-5) LAN cable, plug one connector into Port 1 of the redundant Catalyst 2950 and the other end into the front panel of the node controller TCC2/TCC2P card in Slot 11.
- Step 3** Using a cross-over (CAT-5) LAN cable, plug one connector into Port 22 of the first Catalyst 2950 and the other end into Port 22 of the redundant Catalyst 2950.
- Step 4** To connect a subtending shelf to the Catalyst 2950 switches, complete the following:
- Using a cross-over (CAT-5) LAN cable, plug one connector into the front panel of the subtending shelf TCC2/TCC2P card in Slot 7 and plug the other end into Port 2 of the first Catalyst 2950.
 - Using a cross-over (CAT-5) LAN cable, plug one connector into the front panel of the subtending shelf TCC2/TCC2P card in Slot 11 and plug the other end into Port 2 of the redundant Catalyst 2950.
 - Repeat Steps **a** and **b** for each subtending shelf in the multishelf configuration using Ports 3 through 8 on the Catalyst 2950 switches.
-

NTP-G159 Configure a Cisco Catalyst 2950 for a Multishelf Node

Purpose	This procedure configures in IOS the Cisco Catalyst 2950 for a multishelf node configuration. For more information about the Catalyst 2950, refer to the Catalyst 2950 product documentation.
Tools/Equipment	None
Prerequisite Procedures	NTP-G158 Connect a Multishelf Node and Subtending Shelves to a Cisco Catalyst 2950, page 1-80

Required/As Needed	Required
Onsite/Remote	Onsite or remote
Security Level	Superuser

**Note**

When Cisco Catalyst 2950s are used in a multishelf node configuration, the Cisco Catalyst 2950 must be dedicated to multishelf LAN traffic. Cisco Catalyst 2950 ports not used by the multishelf configuration cannot be used for any other task.

Step 1 At the Cisco IOS command line interface (CLI) for the Catalyst switch, enter the following spanning tree commands:

```
Switch(config)#spanning-tree mode rapid-pvst
Switch(config)#no spanning-tree optimize bpdu transmission
Switch(config)#spanning-tree extend system-id
```

Step 2 Enter the following commands to configure Port 1:

```
(Switch(config)#interface FastEthernet0/1
(Switch(config-if)#switchport trunk allowed vlan 1,2
(Switch(config-if)#switchport mode trunk
(Switch(config-if)#switchport nonegotiate
```

Step 3 Enter the following commands to configure Ports 2 through 8. Replace *port* with the port number (2 through 8) and repeat for each port.

```
(Switch(config)#interface FastEthernet0/port
(Switch(config-if)#switchport access vlan 2
(Switch(config-if)#switchport mode access
```

Step 4 Enter the following commands to disable Ports 9 through 21 and disable VLAN management:

```
(Switch(config)#interface FastEthernet0/9 - 21
(Switch(config-if)#shutdown
```

Step 5 Enter the following commands to configure Port 22:

```
(Switch(config)#interface FastEthernet0/22
(Switch(config-if)#switchport trunk allowed vlan 1,2
(Switch(config-if)#switchport mode trunk
```

Step 6 Enter the following commands to configure Ports 23 and 24. Replace *port* with the port number (23 through 24) and repeat for each port.

```
(Switch(config)#interface FastEthernet0/port
(Switch(config-if)#switchport mode access
```

Step 7 Enter the following interface commands:

```
(Switch(config)#interface GigabitEthernet0/1
(Switch(config)#no ip address
(Switch(config)#ip http server

(Switch(config)#interface GigabitEthernet0/2
(Switch(config)#no ip address
(Switch(config)#ip http server

(Switch(config)#interface Vlan1
(Switch(config)#no ip address
(Switch(config)#no ip route-cache
(Switch(config)#ip http server
```

Step 8 Enter the following commands to configure authentication:

```
Switch(config)#line con 0
Switch(config)#line vty 0 4
Switch(config-line)#password yyyyyy
Switch(config-line)#login
Switch(config-line)#line vty 5 15
Switch(config-line)#password yyyyyy
Switch(config-line)#login
Switch(config-line)#end
```

Stop. You have completed this procedure.

NTP-G16 Perform the Shelf Installation Acceptance Test

Purpose	Use this procedure to perform a shelf installation acceptance test for the ONS 15454 ETSI and ONS 15454 ANSI.
Tools/Equipment	Voltmeter Oval and/or block ferrites
Prerequisite Procedures	Applicable procedures in Chapter 1, “Install the Shelf and Common Control Cards”
Required/As Needed	Required
Onsite/Remote	Onsite
Security Level	None

Step 1 If you installed an ONS 15454 ETSI shelf, complete [Table 1-12](#) by verifying that each applicable procedure was completed.

Table 1-12 ONS 15454 ETSI Shelf Installation Task Summary

Description	Completed
NTP-G1 Unpack and Inspect the Shelf Assembly, page 1-6	
NTP-G2 Install the Shelf Assembly, page 1-8	
NTP-G3 Open and Remove the Front Door, page 1-20	
NTP-G4 Open and Remove the FMEC Cover (ETSI Only), page 1-23	
NTP-G6 Install the MIC-A/P and MIC-T/C/P FMECs (ETSI Only), page 1-28	
NTP-G7 Install the Power and Ground, page 1-30	
NTP-G8 Install the Fan-Tray Assembly, page 1-40	
NTP-G10 Attach Wires to Alarm, Timing, LAN, and Craft Pin Connections, page 1-46	
NTP-G12 Install and Close the FMEC Cover (ETSI Only), page 1-61	
NTP-G14 Install DWDM Equipment, page 1-64	
NTP-G15 Install the Common Control Cards, page 1-72	

Table 1-12 ONS 15454 ETSI Shelf Installation Task Summary (continued)

Description	Completed
NTP-G145 Connect a Multishelf Node and Subtending Shelves to an MS-ISC-100T Card, page 1-78 or NTP-G158 Connect a Multishelf Node and Subtending Shelves to a Cisco Catalyst 2950, page 1-80	
NTP-G159 Configure a Cisco Catalyst 2950 for a Multishelf Node, page 1-80 (if you completed NTP-G158 Connect a Multishelf Node and Subtending Shelves to a Cisco Catalyst 2950, page 1-80)	

- Step 2** If you installed an ONS 15454 ANSI shelf, complete [Table 1-13](#) by verifying that each applicable procedure was completed.

Table 1-13 ONS 15454 ANSI Shelf Installation Task Summary

Description	Completed
NTP-G1 Unpack and Inspect the Shelf Assembly, page 1-6	
NTP-G2 Install the Shelf Assembly, page 1-8	
NTP-G3 Open and Remove the Front Door, page 1-20	
NTP-G5 Remove the Backplane Covers (ANSI Only), page 1-26	
NTP-G7 Install the Power and Ground, page 1-30	
NTP-G8 Install the Fan-Tray Assembly, page 1-40	
NTP-G9 Install the Alarm Expansion Panel (ANSI Only), page 1-43	
NTP-G10 Attach Wires to Alarm, Timing, LAN, and Craft Pin Connections, page 1-46	
NTP-G11 Install an External Wire-Wrap Panel on the AEP (ANSI Only), page 1-57	
NTP-G13 Install the Rear Cover (ANSI Only), page 1-62	
NTP-G14 Install DWDM Equipment, page 1-64	
NTP-G15 Install the Common Control Cards, page 1-72	
NTP-G145 Connect a Multishelf Node and Subtending Shelves to an MS-ISC-100T Card, page 1-78 or NTP-G158 Connect a Multishelf Node and Subtending Shelves to a Cisco Catalyst 2950, page 1-80	
NTP-G159 Configure a Cisco Catalyst 2950 for a Multishelf Node, page 1-80 (if you completed NTP-G158 Connect a Multishelf Node and Subtending Shelves to a Cisco Catalyst 2950, page 1-80)	

- Step 3** Complete the “DLP-G35 Inspect the Shelf Installation and Connections” task on page 1-84.
- Step 4** Complete the “DLP-G36 Measure Voltage” task on page 1-84.
- Step 5** Continue with [Chapter 2](#), “Connect the PC and Log into the GUI.”

Stop. You have completed this procedure.

DLP-G35 Inspect the Shelf Installation and Connections

Purpose	Use this task to inspect the shelf installation and connections and verify that everything is installed and connected properly.
Tools/Equipment	None
Prerequisite Procedures	None
Required/As Needed	Required
Onsite/Remote	Onsite
Security Level	None

-
- Step 1** Make sure all external wiring connections on the backplane (that is, power, ground, alarms, etc.) are secure. If a wire or cable is loose, return to the appropriate procedure in this chapter to correct it.
- Step 2** (ETSI only) To check that the FMEC cover is seated correctly, verify that it can be easily closed without disturbing cables.
- Step 3** Return to your originating procedure (NTP).
-

DLP-G36 Measure Voltage

Purpose	Use this task to measure the power to verify correct power and returns.
Tools/Equipment	Voltmeter
Prerequisite Procedures	None
Required/As Needed	Required
Onsite/Remote	Onsite
Security Level	None

-
- Step 1** Using a voltmeter, verify the office ground and power:
- Place the black lead (positive) on the frame ground on the bay. Hold it there while completing Step b.
 - Place the red lead (negative) on the fuse power points on the third-party power distribution panel to verify that they read between -40.5 VDC and -57 VDC (power) and 0 (return ground).
- Step 2** Using a voltmeter, verify the shelf ground and power wiring:
- Place the black lead (positive) on the RET1 and the red lead on the BAT1 point. Verify a reading between -40.5 VDC and -57 VDC. If there is no voltage, check the following and correct if necessary:
 - Battery and ground are reversed to the shelf.
 - Battery is open or missing.
 - Return is open or missing.
- Step 3** Repeat [Step 1](#) and [Step 2](#) for the RET2 and BAT2 of the redundant power supply input.

Step 4 Return to your originating procedure (NTP).



Connect the PC and Log into the GUI

This chapter explains how to connect Windows PCs and Solaris workstations to the Cisco ONS 15454 and how to log into Cisco Transport Controller (CTC) software, which is the ONS 15454 Operation, Administration, Maintenance and Provisioning (OAM&P) user interface. Procedures for connecting to the ONS 15454 ANSI using TL1 are provided in the *Cisco ONS SONET TL1 Command Guide*. Procedures for connecting to the ONS 15454 ETSI using TL1 are provided in the *Cisco ONS 15454 SDH TL1 Command Guide*.



Note

Unless otherwise specified, “ONS 15454” refers to both ANSI and ETSI shelf assemblies.

Before You Begin

This section lists the chapter procedures (NTPs). Turn to a procedure for applicable tasks (DLPs).

1. [NTP-G17 Set Up Computer for CTC, page 2-1](#)—Complete this procedure if your Windows PC or Solaris workstation has never been connected to an ONS 15454.
2. [NTP-G18 Set Up CTC Computer for Local Craft Connection to the ONS 15454, page 2-9](#)—Complete this procedure to set up your computer for an onsite craft connection to the ONS 15454.
3. [NTP-G19 Set Up a CTC Computer for a Corporate LAN Connection to the ONS 15454, page 2-21](#)—Complete this procedure to set up your computer to connect to the ONS 15454 using a corporate LAN.
4. [NTP-G21 Log into the ONS 15454 GUI, page 2-23](#)—Complete this procedure to log into CTC.

NTP-G17 Set Up Computer for CTC

Purpose	This procedure configures your Windows PC or Solaris workstation to run CTC.
Tools/Equipment	Cisco ONS 15454 Release 7.0 software CD
Prerequisite Procedures	Chapter 1, “Install the Shelf and Common Control Cards”
Required/As Needed	Required
Onsite/Remote	Onsite or remote
Security Level	None

**Note**

JRE 1.4.2 or JRE 5.0 is required to log into nodes running Software Release 7.0. (5.0 is the Sun Microsystems version number for JRE 1.5.0.) To log into nodes running Software R4.5 or earlier, you must uninstall JRE 1.4.2 or 5.0 and install JRE 1.3.1. JRE 1.4.2 is provided on the Software R7.0 software CD. Complete the [“DLP-G52 Change the JRE Version” task on page 2-8](#) as needed.

Step 1 If your computer does not have an appropriate browser installed, complete the following:

- To install Netscape 7.x on a Windows PC, download the browser from the following site: <http://channels.netscape.com/ns/browsers/default.jsp>
- To install Internet Explorer 6.x on a Windows PC, download the browser from the following site: <http://www.microsoft.com>
- To install Mozilla 1.7 on a Solaris workstation, download the browser from the following site: <http://www.mozilla.org/releases/#1.7.12>

**Note**

For Windows PCs, only Internet Explorer 6.x and Netscape 7.x are supported. For Solaris workstations, Mozilla 1.7 is the only supported browser.

Step 2 (Windows PC only) Complete the [“DLP-G331 Adjust the Java Virtual Memory Heap Size \(Windows\)” task on page 2-24](#) to increase the size of the JVM heap to improve CTC performance.

Step 3 Complete one of the following:

- If your computer is a Windows PC, complete the [“DLP-G37 Run the CTC Installation Wizard for Windows PCs” task on page 2-2](#).
- If your computer is a Solaris workstation, complete the [“DLP-G38 Run the CTC Installation Wizard for Solaris Workstations” task on page 2-5](#).

Stop. You have completed this procedure.

DLP-G37 Run the CTC Installation Wizard for Windows PCs

Purpose	This task installs the CTC online user manuals, Acrobat Reader 6.0.1, JRE 1.4.2, and the CTC JAR files on Windows PCs.
Tools/Equipment	Cisco ONS 15454 Release 7.0 software CD
Prerequisite Procedures	None
Required/As Needed	This task is required if you will use a Windows computer to run CTC and if any one of the following is true: <ul style="list-style-type: none"> • JRE 1.4.2 or JRE 5.0 is not installed. • CTC online user manuals are not installed and are needed. • CTC JAR files are not installed and are needed.
Onsite/Remote	Onsite or remote
Security Level	None

**Note**

If you will log into nodes running CTC software earlier than Release 4.6, uninstall JRE 1.4.2 or 5.0 and reinstall JRE 1.3.1. To run Software R7.0, uninstall JRE 1.3.1 and reinstall JRE 1.4.2 or 5.0. Software R7.0 supports JRE 1.4.2 or JRE 5.0; JRE 1.4.2 is provided on the software CD.

Step 1 Verify that your computer has the following:

- Processor—Pentium III, 700 Mhz or faster
- RAM—384 MB recommended, 512 MB optimum
- Hard drive—20 GB hard drive recommended with at least 50 MB of space available
- Operating system—Windows 98 (1st and 2nd editions), Windows NT 4.0 (with Service Pack 6a), Windows 2000 (with Service Pack 3), or Windows XP with Service Pack 1

If your operating system is Windows NT 4.0, verify that Service Pack 6a or later is installed. From the Start menu, choose **Programs > Administrative Tools > Windows NT Diagnostics** and check the service pack on the Version tab of the Windows NT Diagnostics dialog box. If Service Pack 6a or later is not installed, do not continue. Install Service Pack 6a following the computer upgrade procedures for your site.

**Note**

Processor and RAM requirements are guidelines. CTC performance is faster if your computer has a faster processor and more RAM.

Step 2 Insert the Cisco ONS 15454 Release 7.0 software CD into your computer CD drive. The installation program begins running automatically. If it does not start, navigate to the CD directory and double-click **setup.exe**.

The Cisco Transport Controller Installation Wizard displays the components that will be installed on your computer:

- Java Runtime Environment 1.4.2
- Acrobat Reader 6.0.1
- Online User Manuals
- CTC JAR files

**Note**

JRE 1.4.2 or 5.0 is required to run Release 7.0. Preinstalling the CTC JAR files saves time at initial login. If the JAR files are not installed, they are downloaded from the TCC2/TCC2P card the first time you log in.

Step 3 Click **Next**.

Step 4 Complete one of the following:

- Click **Typical** to install the Java Runtime Environment, CTC JAR files, online user manuals, and Acrobat Reader. If you already have JRE 1.4.2 or 5.0 installed on your computer, choose **Custom**.
- Click **Custom** if you want to choose the components that you want to install. By default, Acrobat Reader and the online user manuals are selected.

Step 5 Click **Next**.

Step 6 Complete the following, as applicable:

- If you selected Typical in [Step 4](#), skip this step and continue with [Step 7](#).

- If you selected Custom in [Step 4](#), check the CTC component that you want to install and click **Next**.
 - If you selected Online User Manuals, continue with [Step 7](#).
 - If you did not select Online User Manuals, continue with [Step 9](#).
- Step 7** The directory where the installation wizard will install the CTC online user manuals appears. The default is C:\Program Files\Cisco\CTC\Documentation.
- If you want to change the CTC online user manuals directory, type the new directory path in the Directory Name field, or click **Browse** to navigate to the directory.
 - If you do not want to change the directory, continue with [Step 8](#).
- Step 8** Click **Next**.
- Step 9** Review the components that will be installed. If you want to change the components, complete one of the following. If not, proceed to [Step 10](#).
- If you selected Typical in [Step 4](#), click **Back** twice to return to the installation setup type page. Choose **Custom** and repeat Steps 5 through 8.
 - If you selected Custom in [Step 4](#), click **Back** once or twice (depending on the components selected) until the component selection page appears. Repeat Steps 5 through 8.
- Step 10** Click **Next**. It might take a few minutes for the JRE installation wizard to appear. If you selected Custom in [Step 4](#) and you don't need to install a JRE, continue with [Step 12](#).
- Step 11** To install the JRE, complete the following:
- a. In the Java 2 Runtime Environment License Agreement dialog box, view the license agreement and choose one of the following:
 - I accept the terms of the license agreement—Accepts the license agreement. Continue with [Step b](#).
 - I do not accept the terms of the license agreement—Disables the Next button on the Java 2 Runtime Environment License Agreement dialog box. Click **Cancel** to return to the CTC installation wizard. CTC will not install the JRE. Continue with [Step 12](#).
-
-  **Note** If JRE 1.4.2 is already installed on your computer, the License Agreement dialog box does not appear. You must click Next and then choose Modify to change the JRE installation, or Remove to uninstall the JRE. If you choose Modify and click Next, continue with [Step e](#). If you choose Remove and click Next, continue with [Step i](#).
-
- b. Click **Next**.
 - c. Choose one of the following:
 - Click **Typical** to install all JRE features. If you select Typical, the JRE version installed will automatically become the default JRE version for your browsers.
 - Click **Custom** if you want to select the components to install and select the browsers that will use the JRE version.
 - d. Click **Next**.
 - e. If you selected Typical, continue with [Step i](#). If you selected Custom, click the drop-down list for each program feature that you want to install and choose the desired setting. The program features include:
 - Java 2 Runtime Environment—(Default) Installs JRE 1.4.2 with support for European languages.

- Support for Additional Languages—Adds support for non-European languages.
- Additional Font and Media Support—Adds Lucida fonts, Java Sound, and color management capabilities.

The drop-down list options for each program feature include:

- This feature will be installed on the local hard drive—Installs the selected feature.
- This feature and all subfeatures will be installed on the local hard drive—Installs the selected feature and all subfeatures.
- Don't install this feature now—Does not install the feature (not an option for Java 2 Runtime Environment).

To modify the directory where the JRE version is installed, click **Change**, navigate to the desired directory, and click **OK**.

- f. Click **Next**.
- g. In the Browser Registration dialog box, check the browsers that you want to register with the Java Plug-In. The JRE version will be the default for the selected browsers. It is acceptable to leave both browser check boxes unchecked.



Note Setting the JRE as the default for these browsers might cause problems with these browsers.

- h. Click **Next**.
- i. Click **Finish**.



Note If you are uninstalling the JRE, click **Remove**.

- Step 12** In the Cisco Transport Controller Installation Wizard, click **Next**. The online user manuals and/or Acrobat Reader are installed.
- Step 13** Click **Finish**.
- Step 14** Return to your originating procedure (NTP).

DLP-G38 Run the CTC Installation Wizard for Solaris Workstations

Purpose	This task installs the CTC online user manuals, Acrobat 6.0.1, and JRE 1.4.2 on Solaris workstations, as necessary.
Tools/Equipment	Cisco ONS 15454 Release 7.0 software CD
Prerequisite Procedures	None
Required/As Needed	This task is required if you will use a Solaris workstation to run CTC and any of the following are true: <ul style="list-style-type: none"> • JRE 1.4.2 or 5.0 is not installed. • CTC online user manuals are not installed and are needed.
Onsite/Remote	Onsite or remote
Security Level	None

**Note**

If you will log into nodes running CTC software earlier than Release 4.6, uninstall JRE 1.4.2 or 5.0 and reinstall JRE 1.3.1. To run Software R7.0, uninstall JRE 1.3.1 and reinstall JRE 1.4.2 or 5.0. Software R7.0 supports JRE 1.4.2 or JRE 5.0; JRE 1.4.2 is provided on the software CD.

Step 1 Verify that your computer has the following:

- RAM—384 MB recommended, 512 MB optimum
- Hard drive—20 GB hard drive recommended with at least 50 MB of space available
- Operating system—Solaris 8 or 9

**Note**

These requirements are guidelines. CTC performance is faster if your computer has a faster processor and more RAM.

Step 2 Change the directory. Type:

```
cd /cdrom/cdrom0/
```

Step 3 From the techdoc454 CD directory, type:

```
./setup.bat
```

The Cisco Transport Controller Installation Wizard displays the components that will be installed on your computer:

- Java Runtime Environment 1.4.2
- Acrobat Reader 6.0.1
- Online User Manuals
- CTC JAR files

Step 4 Click **Next**.

Step 5 Complete one of the following:

- Click **Typical** to install both the Java Runtime Environment and online user manuals. If you already have JRE 1.4.2 or 5.0 installed on your computer, choose **Custom**.
- Click **Custom** if you want to install either the JRE or the online user manuals.

Step 6 Click **Next**.

Step 7 Complete the following, as applicable:

- If you selected Typical in [Step 5](#), continue with [Step 8](#).
- If you selected Custom in [Step 5](#), check the CTC component that you want to install and click **Next**.
 - If you selected Online User Manuals, continue with [Step 8](#).
 - If you did not select Online User Manuals, continue with [Step 10](#).

Step 8 The directory where the installation wizard will install the CTC online user manuals appears. The default is /usr/doc/ctc.

- If you want to change the CTC online user manuals directory, type the new directory path in the Directory Name field, or click **Browse** to navigate to the directory.
- If you do not want to change the CTC online user manuals directory, skip this step.

Step 9 Click **Next**.

- Step 10** Review the components that will be installed.
- If you selected Typical in [Step 5](#), click **Back** twice to return to the installation setup type page. Choose **Custom** and repeat Steps 6 through 9.
 - If you selected Custom in [Step 5](#), click **Back** once or twice (depending on the components selected) until you reach the component selection page and check the desired components. Repeat Steps 7 through 9.
- Step 11** Click **Next**. It might take a few minutes for the JRE installation wizard to appear. If you selected Custom in [Step 4](#) and need to install the JRE, continue with [Step 13](#).
- Step 12** To install the JRE, complete the following:
- a. In the Java 2 Runtime Environment License Agreement dialog box, view the license agreement and choose one of the following:
 - I accept the terms of the license agreement—Accepts the license agreement. Continue with [Step b](#).
 - I do not accept the terms of the license agreement—Disables the Next button on the Java 2 Runtime Environment License Agreement dialog box. Click **Cancel** to return to the CTC installation wizard. CTC will not install the JRE. Continue with [Step 13](#).



Note If JRE 1.4.2 is already installed on your computer, the License Agreement dialog box does not appear. You must click Next and then choose Modify to change the JRE installation or Remove to uninstall the JRE. If you choose Modify and click Next, continue with [Step e](#). If you choose Remove and click Next, continue with [Step i](#).

- b. Click **Next**.
- c. Choose one of the following:
 - Click **Typical** to install all JRE features. If you select Typical, the JRE version installed will automatically become the default JRE version for your browsers.
 - Click **Custom** if you want to select the components to install and select the browsers that will use the JRE version.
- d. Click **Next**.
- e. If you selected Typical, continue with [Step i](#). If you selected Custom, click the drop-down list for each program feature that you want to install and choose the desired setting. The program features include:
 - Java 2 Runtime Environment—(Default) Installs JRE 1.4.2 with support for European languages.
 - Support for Additional Languages—Adds support for non-European languages.
 - Additional Font and Media Support—Adds Lucida fonts, Java Sound, and color management capabilities.

The drop-down list options for each program feature include:

- This feature will be installed on the local hard drive—Installs the selected feature.
- This feature and all subfeatures will be installed on the local hard drive—Installs the selected feature and all subfeatures.
- Don't install this feature now—Does not install the feature (not an option for Java 2 Runtime Environment).

To modify the directory where the JRE version is installed, click **Change**, navigate to the desired directory, and click **OK**.

- f. Click **Next**.
- g. In the Browser Registration dialog box, check the browsers that you want to register with the Java Plug-In. The JRE version will be the default for the selected browsers. It is acceptable to leave both browser check boxes unchecked.



Note Setting the JRE version as the default for these browsers might cause problems with these browsers.

- h. Click **Next**.
- i. Click **Finish**.



Note If you are uninstalling the JRE, click **Remove**.

Step 13 In the Cisco Transport Controller Installation Wizard, click **Next**. The online user manuals are installed.

Step 14 Click **Finish**.



Note Be sure to record the names of the directories you choose for JRE and the online user manuals.

Step 15 Return to your originating procedure (NTP).

DLP-G52 Change the JRE Version

Purpose	This task changes the JRE version, which is useful if you would like to upgrade to a later JRE version from an earlier one without using the software or documentation CD. This does not affect the browser default version. After selecting the desired JRE version, you must exit CTC. The next time you log into a node, the new JRE version will be used.
Tools	None
Prerequisite Procedures	DLP-G46 Log into CTC, page 2-25
Required/As Needed	As needed
Onsite/Remote	Onsite or remote
Security Level	Provisioning or higher

Step 1 From the Edit menu, choose **Preferences**.

Step 2 Click the **JRE** tab. The JRE tab shows the current JRE version and the recommended and supported versions.

Step 3 Click the **Browse** button and navigate to the JRE directory on your computer.

Step 4 Choose the JRE version.

Step 5 Click **Open**, then click **OK**.

- Step 6** From the File menu, choose **Exit**.
- Step 7** In the confirmation dialog box, click **Yes**.
- Step 8** Log out of the ONS node.
- Step 9** In the web browser that you used to log into the node, click **Delete CTC Cache**.
- Step 10** Click **Yes** on the confirmation dialog box, then close the browser window.
- Step 11** Complete the “[DLP-G46 Log into CTC](#)” task on page 2-25.
- Step 12** Return to your originating procedure (NTP).
-

NTP-G18 Set Up CTC Computer for Local Craft Connection to the ONS 15454

Purpose	This procedure explains how to set up a PC running Windows or a Solaris workstation for an onsite local craft connection to the ONS 15454.
Tools/Equipment	Network interface card (NIC), also referred to as an Ethernet card Straight-through (CAT-5) LAN cable
Prerequisite Procedures	NTP-G17 Set Up Computer for CTC , page 2-1
Required/As Needed	As needed
Onsite/Remote	Onsite or remote
Security Level	None

- Step 1** Complete one of the CTC computer setup tasks shown in [Table 2-1](#) based on your CTC connection environment. For initial setup, use Option 1 or 3 if you are setting up a Windows PC. Use Option 4 if you are setting up a Solaris workstation.

Table 2-1 CTC Computer Setup for Local Craft Connections to the ONS 15454

Option	CTC Connection Environment	CTC Computer Setup Task
1	<ul style="list-style-type: none"> You are connecting from a Windows PC. You will connect to one ONS 15454. You need to access non-ONS 15454 applications such as ping and tracert (trace route). 	DLP-G39 Set Up a Windows PC for Craft Connection to an ONS 15454 on the Same Subnet Using Static IP Addresses, page 2-11
2	<ul style="list-style-type: none"> You are connecting from a Windows PC. Your network uses Dynamic Host Configuration Protocol (DHCP) for assignment of host IP addresses. The CTC computer is provisioned for DHCP. The ONS 15454 has DHCP forwarding enabled. The ONS 15454 is connected to a DHCP server. <p>Note The ONS 15454 does not provide IP addresses. If DHCP is enabled, it passes DHCP requests to an external DHCP server.</p>	DLP-G40 Set Up a Windows PC for Craft Connection to an ONS 15454 Using Dynamic Host Configuration Protocol, page 2-13 Note Do not use this task for initial node turn-up. Use the task only if DHCP forwarding is enabled on the ONS 15454. By default, DHCP is not enabled. To enable it, see the “NTP-G26 Set Up CTC Network Access” procedure on page 3-13 .
3	<ul style="list-style-type: none"> You are connecting from a Windows PC. You will connect to ONS 15454s at different locations and times and do not wish to reconfigure your PC’s IP settings each time. You will not access or use non-ONS 15454 applications such as ping and tracert (trace route). If you are using an ANSI shelf, you will connect to the TCC2/TCC2P Ethernet port or backplane LAN pins either directly or through a hub. If you are using an ETSI shelf, you will connect to the ONS 15454 Ethernet port or the RJ-45 jack on the MIC-C/T/P FMEC either directly or through a hub. If you are using an ANSI or ETSI multishelf node, you will connect to the patch panel DCN port or the Catalyst 2950 using a straight-through (CAT 5) LAN cable. 	DLP-G41 Set Up a Windows PC for Craft Connection to an ONS 15454 Using Automatic Host Detection, page 2-16
4	<ul style="list-style-type: none"> You are connecting from a Solaris workstation. You will connect to one ONS 15454. You need to access non-ONS 15454 applications such as ping and tracert (trace route). 	DLP-G42 Set Up a Solaris Workstation for a Craft Connection to an ONS 15454, page 2-19

- Step 2** Connect a straight-through CAT-5 LAN cable from the Windows PC or Solaris workstation NIC to one of the following:
- The RJ-45 (LAN) port on the active or standby TCC2/TCC2P card. Use this method for the initial shelf turn-up.
 - The RJ-45 (LAN) port on a hub or switch to which the ONS 15454 is physically connected
 - For multishelf mode, the DCN RJ-45 (LAN) port on the Ethernet Adapter Panel (EAP) or Port 23 or 24 of the Catalyst 2950

**Note**

For instructions on crimping your own straight-through (CAT-5) LAN cables, refer to the *Cisco ONS 15454 DWDM Troubleshooting Guide*.

- Step 3** After setting up your CTC computer, continue with the “[NTP-G21 Log into the ONS 15454 GUI](#)” procedure on page 2-23 as needed.
- Stop. You have completed this procedure.**

DLP-G39 Set Up a Windows PC for Craft Connection to an ONS 15454 on the Same Subnet Using Static IP Addresses

Purpose	This task sets up your computer for a local craft connection to the ONS 15454 when: <ul style="list-style-type: none"> You will connect to one ONS 15454; if you will connect to multiple ONS 15454s, you might need to reconfigure your computer’s IP settings each time you connect to an ONS 15454. You need to use non-ONS 15454 applications such as ping and tracert (trace route).
Tools/Equipment	None
Prerequisite Procedures	NTP-G17 Set Up Computer for CTC, page 2-1
Required/As Needed	As needed
Onsite/Remote	Onsite
Security Level	None

- Step 1** Verify the operating system that is installed on your computer:
- From the Windows Start menu, choose **Settings > Control Panel**.
 - In the Control Panel window, double-click the **System** icon.
 - On the General tab of the System Settings window, verify that the Windows operating system is one of the following: Windows 98, Windows NT 4.0, Windows 2000, or Windows XP.
- Step 2** According to the Windows operating system installed on your computer, perform one of the following steps:
- For Windows 98, complete [Step 3](#).
 - For Windows NT 4.0, complete [Step 4](#).
 - For Windows 2000, complete [Step 5](#).
 - For Windows XP, complete [Step 6](#).
- Step 3** If you have Windows 98 installed on your PC, complete the following steps to change its TCP/IP configuration:
- From the Windows Start menu, choose **Settings > Control Panel**.
 - In the Control Panel dialog box, click the **Network** icon.
 - In the Network dialog box, choose **TCP/IP** for your NIC card, then click **Properties**.

- d. In the TCP/IP Properties dialog box, click the **DNS Configuration** tab and choose **Disable DNS**.
- e. Click the **WINS Configuration** tab and choose **Disable WINS Resolution**.
- f. Click the **IP Address** tab.
- g. In the IP Address window, click **Specify an IP address**.
- h. In the IP Address field, enter an IP address that is identical to the ONS 15454 IP address except for the last octet. The last octet must be 1 or 3 through 254. This IP address appears on the LCD unless its display is suppressed during node provisioning.
- i. In the Subnet Mask field, type the same subnet mask as the ONS 15454. The default is **255.255.255.0** (24 bit).
- j. Click **OK**.
- k. In the TCP/IP dialog box, click the **Gateway** tab.
 - l. In the New Gateway field, type the ONS 15454 IP address. Click **Add**.
- m. Verify that the IP address appears in the Installed Gateways field, then click **OK**.
- n. When the prompt to restart your PC appears, click **Yes**.
- o. Proceed to [Step 7](#).

Step 4 If you have Windows NT 4.0 installed on your PC, complete the following steps to change its TCP/IP configuration:

- a. From the Windows Start menu, choose **Settings > Control Panel**.
- b. In the Control Panel dialog box, click the **Network** icon.
- c. In the Network dialog box, click the **Protocols** tab, choose **TCP/IP Protocol**, then click **Properties**.
- d. Click the **IP Address** tab.
- e. In the IP Address window, click **Specify an IP address**.
- f. In the IP Address field, enter an IP address that is identical to the ONS 15454 IP address shown on the ONS 15454 LCD except for the last octet. The last octet must be 1 or 3 through 254.
- g. In the Subnet Mask field, type **255.255.255.0**.
- h. Click **Advanced**.
 - i. In the Gateways List, click **Add**. The TCP/IP Gateway Address dialog box appears.
 - j. Type the ONS 15454 IP address in the Gateway Address field.
 - k. Click **Add**.
 - l. Click **OK**.
- m. Click **Apply**.
- n. In some cases, Windows NT 4.0 prompts you to reboot your PC. If you receive this prompt, click **Yes**.
- o. Proceed to [Step 7](#).

Step 5 If you have Windows 2000 installed on your PC, complete the following steps to change its TCP/IP configuration:

- a. From the Windows Start menu, choose **Settings > Network and Dial-up Connections > Local Area Connection**.
- b. In the Local Area Connection Status dialog box, choose the local area connection connected to the PC port connected to the ONS 15454.

- c. Click **Properties**.
- d. On the General tab, choose **Internet Protocol (TCP/IP)**, then click **Properties**.
- e. Click **Use the following IP address**.
- f. In the IP Address field, enter an IP address that is identical to the ONS 15454 IP address shown on the ONS 15454 LCD except for the last octet. The last octet must be 1 or 3 through 254.
- g. In the Subnet Mask field, type **255.255.255.0**.
- h. In the Default Gateway field, type the ONS 15454 IP address.
- i. Click **OK**.
- j. In the Local Area Connection Properties dialog box, click **OK**.
- k. In the Local Area Connection Status dialog box, click **Close**.
- l. Proceed to [Step 7](#).

Step 6 If you have Windows XP installed on your PC, complete the following steps to change its TCP/IP configuration:

- a. From the Windows Start menu, choose **Control Panel > Network Connections**.



Note If the Network Connections menu is not available, right-click the Windows screen and choose **Properties** from the popup menu. Click the **Appearance** tab, then under Scheme, choose **Classic View**.

- b. From the Network Connections dialog box, click the **Local Area Connection** icon.
- c. On the General tab of the Local Area Connection Properties dialog box, choose **Internet Protocol (TCP/IP)**, then click **Properties**.
- d. In the IP Address field, enter an IP address that is identical to the ONS 15454 IP address shown on the ONS 15454 LCD except for the last octet. The last octet must be 1 or 3 through 254.
- e. In the Subnet Mask field, type **255.255.255.0**.
- f. In the Default Gateway field, type the ONS 15454 IP address.
- g. Click **OK**.
- h. In the Local Area Connection Properties dialog box, click **OK**.
- i. In the Local Area Connection Status dialog box, click **Close**.

Step 7 Return to your originating procedure (NTP).

DLP-G40 Set Up a Windows PC for Craft Connection to an ONS 15454 Using Dynamic Host Configuration Protocol

Purpose	This task sets up your computer for craft connection to the ONS 15454 using DHCP.
Tools/Equipment	None

Prerequisite Procedures	NTP-G17 Set Up Computer for CTC, page 2-1 NTP-G26 Set Up CTC Network Access, page 3-13
Required/As Needed	As needed
Onsite/Remote	Onsite
Security Level	None

**Note**

Do not use this task for initial node turn-up. Use the task only if DHCP forwarding is enabled on the ONS 15454. By default, DHCP is not enabled. To enable it, see the [“NTP-G26 Set Up CTC Network Access” procedure on page 3-13](#).

**Note**

The ONS 15454 does not provide the IP addresses. If DHCP forwarding is enabled, it passes DHCP requests to an external DHCP server.

- Step 1** Verify the operating system that is installed on your computer:
- From the Windows Start menu, choose **Settings > Control Panel**.
 - In the Control Panel window, double-click the **System** icon.
 - On the General tab of the System Settings window, verify that the Windows operating system is one of the following: Windows 98, Windows NT 4.0, Windows 2000, or Windows XP.
- Step 2** According to the Windows operating system installed on your computer, perform one of the following steps:
- For Windows 98, complete [Step 3](#).
 - For Windows NT 4.0, complete [Step 4](#).
 - For Windows 2000, complete [Step 5](#).
 - For Windows XP, complete [Step 6](#).
- Step 3** If you have Windows 98 installed on your PC, complete the following steps to change its TCP/IP configuration:
- From the Windows Start menu, choose **Settings > Control Panel**.
 - In the Control Panel dialog box, click the **Network** icon.
 - In the Network dialog box, select **TCP/IP** for your NIC, then click **Properties**.
 - In the TCP/IP Properties dialog box, click the **DNS Configuration** tab and choose **Disable DNS**.
 - Click the **WINS Configuration** tab and choose **Disable WINS Resolution**.
 - Click the **IP Address** tab.
 - In the IP Address window, click **Obtain an IP address automatically**.
 - Click **OK**.
 - When the prompt to restart your PC appears, click **Yes**.
 - Proceed to [Step 7](#).
- Step 4** If you have Windows NT 4.0 installed on your PC, complete the following steps to change its TCP/IP configuration:
- From the Windows Start menu, choose **Settings > Control Panel**.

- b. In the Control Panel dialog box, click the **Network** icon.
- c. In the Network dialog box, click the **Protocols** tab, choose **TCP/IP Protocol**, then click **Properties**.
- d. Click the **IP Address** tab.
- e. In the IP Address window, click **Obtain an IP address from a DHCP server**.
- f. Click **OK**.
- g. Click **Apply**.
- h. If Windows prompts you to restart your PC, click **Yes**.
- i. Proceed to [Step 7](#).

Step 5 If you have Windows 2000 installed on your PC, complete the following steps to change its TCP/IP configuration:

- a. From the Windows Start menu, choose **Settings > Network and Dial-up Connections > Local Area Connection**.
- b. In the Local Area Connection Status dialog box, choose the local area connection connected to the PC port connected to the ONS 15454.
- c. In the Local Area Connection Status dialog box, click **Properties**.
- d. On the General tab, choose **Internet Protocol (TCP/IP)**, then click **Properties**.
- e. Click **Obtain an IP address automatically**.
- f. Click **OK**.
- g. In the Local Area Connection Properties dialog box, click **OK**.
- h. In the Local Area Connection Status dialog box, click **Close**.
- i. Proceed to [Step 7](#).

Step 6 If you have Windows XP installed on your PC, complete the following steps to change its TCP/IP configuration:

- a. From the Windows Start menu, choose **Control Panel > Network Connections**.



Note If the Network Connections menu is not available, right-click the Windows screen and choose **Properties** from the popup menu. Click the **Appearance** tab, then under Scheme, choose **Classic View**.

- b. From the Network Connections dialog box, click the **Local Area Connection** icon.
- c. On the General tab of the Local Area Connection Properties dialog box, click **Properties**.
- d. On the General tab, choose **Internet Protocol (TCP/IP)**, then click **Properties**.
- e. Click **Obtain an IP address automatically**.
- f. Click **OK**.
- g. In the Local Area Connection Properties dialog box, click **OK**.
- h. In the Local Area Connection Status dialog box, click **Close**.

Step 7 Return to your originating procedure (NTP).

DLP-G41 Set Up a Windows PC for Craft Connection to an ONS 15454 Using Automatic Host Detection

Purpose	This task sets up your computer for local craft connection to the ONS 15454 when: <ul style="list-style-type: none"> You are using an ANSI shelf, you will connect to the ONS 15454 Ethernet port or backplane LAN pins either directly or through a hub. You are using an ETSI shelf, you will connect to the ONS 15454 Ethernet port or the RJ-45 jack on the MIC-C/T/P FMEC either directly or through a hub. You will connect to multiple ONS 15454s and do not want to reconfigure your IP address each time. You do not need to access non-ONS 15454 applications such as ping and tracert (trace route).
Tools/Equipment	None
Prerequisite Procedures	NTP-G17 Set Up Computer for CTC, page 2-1
Required/As Needed	As needed
Onsite/Remote	Onsite
Security Level	None

-
- Step 1** Verify the operating system that is installed on your computer:
- From the Windows Start menu, choose **Settings > Control Panel** or, for Windows XP, **Control Panel > System**.
 - In the Control Panel window, double-click the **System** icon.
 - On the General tab of the System Settings window, verify that the Windows operating system is one of the following: Windows 98, Windows NT 4.0, Windows 2000, or Windows XP.
- Step 2** According to the Windows operating system installed on your computer, perform one of the following steps:
- For Windows 98, complete [Step 3](#).
 - For Windows NT 4.0, complete [Step 4](#).
 - For Windows 2000, complete [Step 5](#).
 - For Windows XP, complete [Step 6](#).
- Step 3** If you have Windows 98 installed on your PC, complete the following steps to change its TCP/IP configuration:
- From the Windows Start menu, choose **Settings > Control Panel**.
 - In the Control Panel dialog box, click the **Network** icon.
 - In the Network dialog box, select **TCP/IP** for your NIC, then click **Properties**.
 - In the TCP/IP Properties dialog box, click the **DNS Configuration** tab and choose **Disable DNS**.
 - Click the **WINS Configuration** tab and choose **Disable WINS Resolution**.
 - Click the **IP Address** tab.
 - In the IP Address window, click **Specify an IP address**.

- h. In the IP Address field, enter any legitimate IP address other than the node IP address as indicated on the LCD of the ONS 15454. The default IP address is 192.1.0.2.



Note You can suppress the LCD IP address display using CTC. For more information, see the “[DLP-G162 Change IP Settings](#)” task on page 10-19.

- i. In the Subnet Mask field, type the same subnet mask as the ONS 15454. The default is **255.255.255.0** (24 bit).
- j. Click **OK**.
- k. In the TCP/IP dialog box, click the **Gateway** tab.
 - l. In the New Gateway field, type the address entered in Step h. Click **Add**.
- m. Verify that the IP address appears in the Installed Gateways field, then click **OK**.
- n. When the prompt to restart your PC appears, click **Yes**.
- o. Proceed to [Step 7](#).

Step 4 If you have Windows NT 4.0 installed on your PC, complete the following steps to change its TCP/IP configuration:

- a. From the Windows Start menu, choose **Settings > Control Panel**.
- b. In the Control Panel dialog box, click the **Network** icon.
- c. In the Network dialog box, click the **Protocols** tab, choose **TCP/IP Protocol**, then click **Properties**.
- d. Click the **IP Address** tab.
- e. In the IP Address window, click **Specify an IP address**.
- f. In the IP Address field, enter any legitimate IP address other than the node IP address as indicated on the LCD of the ONS 15454. The default IP address is 192.1.0.2.



Note You can suppress the LCD IP address display using CTC. For more information, see the “[DLP-G162 Change IP Settings](#)” task on page 10-19.

- g. In the Subnet Mask field, type the same subnet mask as the ONS 15454. The default is **255.255.255.0** (24 bit).
- h. Click **Advanced**.
- i. In the Gateways List, click **Add**. The TCP/IP Gateway Address dialog box appears.
- j. Type the IP address entered in Step f in the Gateway Address field.
- k. Click **Add**.
- l. Click **OK**.
- m. Click **Apply**.
- n. Reboot your PC.
- o. Proceed to [Step 7](#).

Step 5 If you have Windows 2000 installed on your PC, complete the following steps to change its TCP/IP configuration:

- a. From the Windows Start menu, choose **Settings > Network and Dial-up Connections > Local Area Connection**.

- b. In the Local Area Connection Status dialog box, click **Properties**.
- c. On the General tab, choose **Internet Protocol (TCP/IP)**, then click **Properties**.
- d. Click **Use the following IP address**.
- e. In the IP Address field, enter any legitimate IP address other than the node IP address as indicated on the LCD of the ONS 15454. The default IP address is 192.1.0.2.



Note You can suppress the LCD IP address display using CTC. For more information, see the “[DLP-G162 Change IP Settings](#)” task on page 10-19.

- f. In the Subnet Mask field, type the same subnet mask as the ONS 15454. The default is **255.255.255.0** (24 bit).
- g. Type the IP address entered in Step e in the Gateway Address field.
- h. Click **OK**.
- i. In the Local Area Connection Properties dialog box, click **OK**.
- j. In the Local Area Connection Status dialog box, click **Close**.
- k. Proceed to [Step 7](#).

Step 6 If you have Windows XP installed on your PC, complete the following steps to change its TCP/IP configuration:

- a. From the Windows Start menu, choose **Control Panel > Network Connections**.



Note If the Network Connections menu is not available, click **Switch to Classic View**.

- b. From the Network Connections dialog box, right-click the **Local Area Connection** icon and select **Properties**.
- c. Scroll to the bottom of the Local Area Connection Properties dialog box. Click **Internet Protocol (TCP/IP)** to select it, then click **Properties**.
- d. In the IP Address field, enter any legitimate IP address other than the node IP address as indicated on the LCD of the ONS 15454. The default IP address is 192.1.0.2.
- e. Select the **Use the Following IP Address:** radio button.



Note You can suppress the LCD IP address display using CTC. For more information, see the “[DLP-G162 Change IP Settings](#)” task on page 10-19.

- f. In the Subnet Mask field, type the same subnet mask as the ONS 15454. The default is **255.255.255.0** (24 bit).
- g. Type the IP address entered in Step d in the Gateway Address field.
- h. Click **OK**.
- i. In the Local Area Connection Properties dialog box, click **Close**.

Step 7 Return to your originating procedure (NTP).

DLP-G42 Set Up a Solaris Workstation for a Craft Connection to an ONS 15454

Purpose	This task sets up a Solaris workstation for a craft connection to the ONS 15454.
Tools/Equipment	None
Prerequisite Procedures	NTP-G17 Set Up Computer for CTC, page 2-1
Required/As Needed	As needed
Onsite/Remote	Onsite
Security Level	None

Step 1 Log into the workstation as the root user.

Step 2 Check to see if the interface is plumbed by typing:

```
# ifconfig device
```

For example:

```
# ifconfig hme1
```

- If the interface is plumbed, a message similar to the following appears:

```
hme1:flags=1000842<BROADCAST,RUNNING,MULTICAST,IPv4>mtu 1500 index 2 inet 0.0.0.0
netmask 0
```

If a message similar to this one appears, go to [Step 4](#).

- If the interface is not plumbed, a message similar to the following appears:

```
ifconfig: status: SIOCGLIFFLAGS: hme1: no such interface.
```

If a message similar to this one appears, go to [Step 3](#).

Step 3 Plumb the interface by typing:

```
# ifconfig device plumb
```

For example:

```
# ifconfig hme1 plumb
```

Step 4 Configure the IP address on the interface by typing:

```
# ifconfig interface ip-address netmask netmask up
```

For example:

```
# ifconfig hme0 192.1.0.3 netmask 255.255.255.0 up
```



Note Enter an IP address that is identical to the ONS 15454 IP address except for the last octet. The last octet must be 1 or 3 through 254.

Step 5 In the Subnet Mask field, type **255.255.255.0**. Skip this step if you checked Craft Access Only on the Provisioning > Network > General > Gateway Settings tab.

Step 6 Test the connection:

- a. Start Mozilla.

- b. Enter the ONS 15454 IP address in the web address (URL) field. If the connection is established, a Java Console window, CTC caching messages, and the Cisco Transport Controller Login dialog box appear. If this occurs, go to Step 2 of the “[DLP-G46 Log into CTC](#)” task on page 2-25 to complete the login. If the Login dialog box does not appear, complete Steps c and d.

- c. At the prompt, type:

```
ping ONS-15454-IP-address
```

For example, to connect to an ONS 15454 with a default IP address of 192.1.0.2, type:

```
ping 192.1.0.2
```

If your workstation is connected to the ONS 15454, the following message appears:

```
IP-address is alive
```



Note Skip this step if you checked the Craft Access Only check box on the Provisioning > Network > General > Gateway Settings tab.

- d. If CTC is not responding, a “no answer from x.x.x.x” message appears. Verify the IP and subnet mask information. Check that the cables connecting the workstation to the ONS 15454 are securely attached. Check the link status by typing:

```
# ndd -set /dev/device instance 0
```

```
# ndd -get /dev/device link_status
```

For example:

```
# ndd -set /dev/hme instance 0
```

```
# ndd -get /dev/hme link_status
```

A result of “1” means the link is up. A result of “0” means the link is down.



Note Check the man page for ndd. For example, type: # `man ndd`.

Step 7 Return to your originating procedure (NTP).

NTP-G19 Set Up a CTC Computer for a Corporate LAN Connection to the ONS 15454

Purpose	This procedure sets up your computer to access the ONS 15454 through a corporate LAN.
Tools/Equipment	NIC, also referred to as an Ethernet card Straight-through (CAT-5) LAN cable
Prerequisite Procedures	<ul style="list-style-type: none"> • NTP-G17 Set Up Computer for CTC, page 2-1 • The ONS 15454 must be provisioned for LAN connectivity, including IP address, subnet mask, default gateway. • The ONS 15454 must be physically connected to the corporate LAN.
Required/As Needed	As needed
Onsite/Remote	Onsite or remote
Security Level	None

-
- Step 1** If your computer is already connected to the corporate LAN, go to [Step 3](#). If you changed your computer's network settings for craft access to the ONS 15454, change the settings back to the corporate LAN access settings. This generally means:
- Set the IP Address on the TCP/IP dialog box back to **Obtain an IP address automatically** (Windows 2000 and XP) or **Obtain an IP address from a DHCP server** (Windows NT 4.0).
 - If your LAN requires that Domain Name System (DNS) or Windows Internet Naming Service (WINS) be enabled, change the setting on the DNS Configuration or WINS Configuration tab of the TCP/IP dialog box.
- Step 2** Complete one of the following:
- For a single-shelf node, connect a straight-through (CAT-5) LAN cable from the PC or Solaris workstation NIC card to a corporate LAN port.
 - For a multishelf node, connect a straight-through (CAT-5) LAN cable from the PC or Solaris workstation to the DCN RJ-45 (LAN) port on the EAP or to Port 23 or 24 of the Catalyst 2950.
- Step 3** If your computer is connected to a proxy server, disable proxy service or add the ONS 15454 nodes as exceptions. To disable or bypass proxy service, complete one of the following tasks, depending on the web browser that you use:
- [DLP-G43 Disable or Bypass Proxy Service Using Internet Explorer \(Windows\), page 2-22](#)
 - [DLP-G44 Disable or Bypass Proxy Service Using Netscape \(Windows\) or Mozilla \(Solaris\), page 2-22](#)
- Step 4** Continue with the “[NTP-G21 Log into the ONS 15454 GUI](#)” procedure on page 2-23.
- Stop. You have completed this procedure.**
-

DLP-G43 Disable or Bypass Proxy Service Using Internet Explorer (Windows)

Purpose	This task disables or bypasses proxy service for PCs running Internet Explorer.
Tools/Equipment	None
Prerequisite Procedures	NTP-G17 Set Up Computer for CTC, page 2-1
Required/As Needed	Required if your computer is connected to a network computer proxy server and your browser is Internet Explorer.
Onsite/Remote	Onsite or remote
Security Level	None

Step 1 From the Start menu, select **Settings > Control Panel**.



Note If your computer is running Windows XP, you can select Control Panel directly from the Start menu. Make sure that you are in Classic View before continuing with this procedure. To switch to Classic View, right-click the Windows screen and choose **Properties** from the popup menu. Click the **Appearance** tab, then under Scheme, choose **Classic View**.

Step 2 In the Control Panel window, choose **Internet Options**.

Step 3 In the Internet Properties dialog box, click **Connections > LAN Settings**.

Step 4 In the LAN Settings dialog box, complete one of the following tasks:

- Uncheck **Use a proxy server** to disable the service.
- To bypass the service, leave **Use a proxy server** selected and click **Advanced**. In the Proxy Setting dialog box under Exceptions, enter the IP addresses of ONS 15454 nodes that you will access. Separate each address with a semicolon. You can insert an asterisk (*) for the host number to include all the ONS 15454s on your network. Click **OK** to close each open dialog box.

Step 5 Return to your originating procedure (NTP).

DLP-G44 Disable or Bypass Proxy Service Using Netscape (Windows) or Mozilla (Solaris)

Purpose	This task disables or bypasses proxy service for Windows PCs running Netscape or Solaris workstations running Mozilla.
Tools/Equipment	None
Prerequisite Procedures	NTP-G17 Set Up Computer for CTC, page 2-1
Required/As Needed	Required if your computer is connected to a network computer proxy server and your browser is Netscape or Mozilla.
Onsite/Remote	Onsite or remote
Security Level	None

-
- Step 1** Open Netscape (Windows) or Mozilla (Solaris).
- Step 2** From the Edit menu, choose **Preferences**.
- Step 3** In the Preferences dialog box under Category, choose **Advanced > Proxies**.
- Step 4** On the right side of the Preferences dialog box under Proxies, perform one of the following options:
- Click the **Direct connection to the Internet** option to disable the proxy server.
 - Click the **Manual proxy configuration** option to add exceptions to the proxy server. Under Manual Proxy Configuration in the No Proxy For field, enter the IP addresses of the ONS 15454 nodes that you will access. Separate each address with a comma. Click **OK** to close each open dialog box.
- Step 5** Return to your originating procedure (NTP).
-

NTP-G21 Log into the ONS 15454 GUI

Purpose	This procedure logs into CTC, the graphical user interface (GUI) software used to manage the ONS 15454. This procedure includes optional node login tasks.
Tools/Equipment	None
Prerequisite Procedures	NTP-G17 Set Up Computer for CTC, page 2-1 One of the following procedures: <ul style="list-style-type: none"> • NTP-G18 Set Up CTC Computer for Local Craft Connection to the ONS 15454, page 2-9 • NTP-G19 Set Up a CTC Computer for a Corporate LAN Connection to the ONS 15454, page 2-21
Required/As Needed	Required
Onsite/Remote	Onsite or remote
Security Level	Retrieve or higher

-
- Step 1** Complete the “[DLP-G46 Log into CTC](#)” task on page 2-25.



Note For information about navigating in CTC, see [Appendix A, “CTC Information and Shortcuts.”](#)

During network topology discovery, CTC polls each node in the network to determine which one contains the most recent version of the CTC software. If CTC discovers a node in the network that has a more recent version of the CTC software than the version you are currently running, CTC generates a message stating that a later version of the CTC has been found in the network. If you have network discovery disabled, CTC will not seek more recent versions of the software. Unreachable nodes are not included in the upgrade discovery.



Note Upgrading the CTC software will overwrite your existing software. You must restart CTC after the upgrade is complete.

- Step 2** As needed, complete the “[DLP-G48 Create Login Node Groups](#)” task on page 2-29. Login node groups allow you to view and manage nodes that have an IP connection but no data communications channel (DCC) connection to the login node.
- Step 3** As needed, complete the “[DLP-G49 Add a Node to the Current Session or Login Group](#)” task on page 2-30.
- Step 4** As needed, complete the “[DLP-G50 Delete a Node from the Current Session or Login Group](#)” task on page 2-31.
- Step 5** As needed, complete the “[DLP-G331 Adjust the Java Virtual Memory Heap Size \(Windows\)](#)” task on page 2-24.
- Step 6** As needed, complete the “[DLP-G51 Delete a Node from a Specific Login Node Group](#)” task on page 2-31.
- Step 7** As needed, complete the “[DLP-G53 Configure the CTC Alerts Dialog Box for Automatic Popup](#)” task on page 2-32.

Stop. You have completed this procedure.

DLP-G331 Adjust the Java Virtual Memory Heap Size (Windows)

Purpose	This task allows you to adjust the Java Virtual Memory (JVM) heap size of a Windows PC from the default 256 MB to the maximum of 512 MB in order to improve CTC performance.
Tools/Equipment	None
Prerequisite procedures	None
Required/As needed	As needed
Onsite/Remote	Onsite or remote
Security Level	Provisioning or higher



Note

The task adjusts the physical memory allocation in the computer RAM so that more space is allocated for CTC. However, less physical memory will be available for other computer processes and programs. If you notice performance degradation of non-CTC programs after completing this task, reduce the JVM allotted to CTC. You may need to repeat the task a few times to find the right balance between JVM allotted to CTC and to other programs on your computer.

- Step 1** From the Windows PC, click **Start > Settings > Control Panel**. > System, or **Start > Control Panel > System** (Windows XP). The Windows Control Panel appears. The System Properties dialog box appears.
- Step 2** Click the **Advanced** tab.
- Step 3** Click **Environmental Variables**. The Environmental Variables dialog box appears.
- Step 4** In the User Variables area, check to see whether a CTC_HEAP variable was created. If yes, complete the following steps. If not, continue with [Step 5](#).
- Check the CTC_HEAP value. If it is 512, continue with [Step 12](#). If not, continue with Step **b**.
 - Click the CTC_HEAP variable and click **Edit**.

- c. In the Edit User Variable dialog box, enter the new JVM heap size. This can be any number between 256 and 512 MB.
 - d. Click **OK**, then continue with [Step 9](#).
- Step 5** click **New**. The New User Variable dialog box appears.
- Step 6** Type “CTC_HEAP” in the Variable Name field.
- Step 7** Type “512” in the Variable Value field.
- Step 8** Click **OK** to close the New User Variable dialog box.
- Step 9** Click **OK** to close the Environmental Variables dialog box.
- Step 10** Click **OK** to close the System Properties dialog box.
- Step 11** Reboot your PC.
- Step 12** Return to your originating procedure (NTP).
-

DLP-G46 Log into CTC

Purpose	This task logs into the graphical user interface (GUI) of CTC.
Tools/Equipment	None
Prerequisite Procedures	<p>NTP-G17 Set Up Computer for CTC, page 2-1</p> <p>One of the following procedures:</p> <ul style="list-style-type: none"> • NTP-G18 Set Up CTC Computer for Local Craft Connection to the ONS 15454, page 2-9 • NTP-G19 Set Up a CTC Computer for a Corporate LAN Connection to the ONS 15454, page 2-21
Required/As Needed	Required
Onsite/Remote	Onsite or remote
Security Level	Retrieve or higher



Note For information about CTC views and navigation, see [Appendix A, “CTC Information and Shortcuts.”](#)

- Step 1** From the computer connected to the ONS 15454, start Netscape (Windows PC), Internet Explorer (Windows PC) or Mozilla (Solaris workstation):
- If you are using a Windows PC, launch Netscape or Internet Explorer from the Windows Start menu or a shortcut icon.
 - If you are using a Solaris workstation, navigate to the directory where Mozilla was installed, then type:

```
# mozilla -install
```
- Step 2** In the Netscape, Internet Explorer, or Mozilla web address (URL) field, enter the ONS 15454 IP address. For initial setup, this is the default IP address, 192.1.0.2.



Note The IP address appears on the LCD. You can suppress the LCD IP address display using CTC after you log in. For more information, see the [“DLP-G162 Change IP Settings” task on page 10-19](#).

Step 3 Press **Enter**. The browser displays a window with a Delete CTC Cache field and information about the Cisco Transport Controller Java and System environments.



Note The Delete CTC Cache field deletes the CTC JAR (Java Archive) files that are downloaded to your computer when you log into an ONS 15454. You perform this action if connectivity problems occur or you want to delete older CTC JAR file versions from your computer. For more information, refer to the “General Troubleshooting” chapter in the *Cisco ONS 15454 DWDM Troubleshooting Guide* and the “CTC Operations” chapter in the *Cisco ONS 15454 DWDM Reference Manual*.



Note If you are logging into ONS 15454 nodes in an operation network that are running different releases of CTC software, log into the node running the most recent release. If you log into a node running an older release, you will receive an INCOMPATIBLE-SW alarm for each node in the network running a new release, and CTC will not be able to manage these nodes. To check the software version of a node, select About CTC from the CTC Help menu. This will display the ONS 15454 software version for each node visible on the network view. If the node is not visible, the software version can be read from the LCD display. To resolve an alarm, refer to the *Cisco ONS 15454 DWDM Troubleshooting Guide*.

Step 4 If a Java Plug-in Security Warning dialog box appears, complete the [“DLP-G47 Install Public-Key Security Certificate” task on page 2-28](#) to install the public-key security certificate required by Software Release 4.1 and later.

After you complete the security certificate dialog box (or if the certificate is already installed), a Java Console window displays the CTC file download status. The web browser displays information about your Java and system environments. If this is the first login, CTC caching messages appear while CTC files are downloaded to your computer. The first time you connect to an ONS 15454, this process can take several minutes. After the download, the CTC Login dialog box appears. (Figure 2-1).

Figure 2-1 Logging into CTC

Cisco Transport Controller

Version: 7.0.0

User Name:

Password:

Node Name:

Additional Nodes:

Disable Network Discovery

Disable Circuit Management

WARNING
This system is restricted to authorized users for business purposes. Unauthorized access is a violation of the law. This service may be monitored for administrative and security reasons. By proceeding, you consent to this monitoring.



Note When the CTC Login dialog box appears, it might be minimized.

Step 5 In the Login dialog box, type a user name and password (both are case sensitive). For initial setup, type the user name **CISCO15** and the password **otbu+1**.



Note The CISCO15 user is provided with every ONS 15454. CISCO15 has Superuser privileges, so you can create other users. You must create another Superuser before you can delete the CISCO15 user. CISCO15 is delivered with the otbu+1 password. To change the password for CISCO15, complete the “[DLP-G191 Change User Password and Security Level on a Single Node](#)” task on page 10-54 after you log in.

Step 6 Each time you log into an ONS 15454, you can make selections about the following login options:

- **Node Name**—Displays the IP address entered in the web browser and a drop-down list of previously entered ONS 15454 IP addresses. You can select any ONS 15454 on the list for the login, or you can enter the IP address (or node name) of any new node where you want to log in.
- **Additional Nodes**—Displays a list of current login node groups. To create a login node group or add additional groups, see the “[DLP-G48 Create Login Node Groups](#)” task on page 2-29.
- **Disable Network Discovery**—Check this box to view only the ONS 15454 (and additional nodes within the login node group, if any) entered in the Node Name field. Nodes linked to this node through DCCs are not discovered and will not appear in CTC network view. Using this option can decrease the CTC startup time in networks with many DCC-connected nodes, and can reduce memory consumption.
- **Disable Circuit Management**—Check this box to disable discovery of existing circuits. Using this option can decrease the CTC initialization time in networks with many existing circuits and reduce memory consumption. After you are logged in, you can enable circuit discovery at any time by choosing the Enable Circuit Discovery button on the Circuits tab.

- Step 7** If you keep Disable Network Discovery unchecked, CTC attempts to upgrade the CTC software by downloading more recent versions of the JAR files it finds during the network discovery. Click **Yes** to allow CTC to download the newer JAR files, or **No** to prevent CTC from downloading the JAR files.



Note Upgrading the CTC software will overwrite your existing software. You must restart CTC after the upgrade is complete.

- Step 8** Click **Login**.

If the login is successful, the CTC node view window (in single-shelf mode) or multishelf view window (in multishelf mode) appears. From here, you can navigate to other CTC views to provision and manage the ONS 15454. If you need to turn up the shelf for the first time, see [Chapter 3, “Turn Up a Node.”](#) If login problems occur, refer to the *Cisco ONS 15454 DWDM Troubleshooting Guide*.

- Step 9** Return to your originating procedure (NTP).

DLP-G47 Install Public-Key Security Certificate

Purpose	This task installs the ITU Recommendation X.509 public-key security certificate. The public-key certificate is required to run Software Release 4.1 or later.
Tools/Equipment	None
Prerequisite Procedures	This task is performed during the “ DLP-G46 Log into CTC ” task on page 2-25 . You cannot perform it outside of this task.
Required/As Needed	Required
Onsite/Remote	Onsite or remote
Security Level	Provisioning or higher

- Step 1** If the Java Plug-in Security Warning dialog box appears, choose one of the following options:



Note The Java Plug-in Security Warning dialog box options that appear depend on the JRE version you are using. If you installed JRE 1.4.2, you will see the following options: Yes, No, Always, and More Details. If you are using JRE 1.3.1_02, you will see the following options (shown in parentheses in the following list): Grant This Session, Deny, Grant Always, and View Certificate.

- Yes (Grant This Session)—Installs the public-key certificate to your PC only for the current session. After the session is ended, the certificate is deleted. This dialog box will appear the next time you log into the ONS 15454.
- No (Deny)—Denies permission to install the certificate. If you choose this option, you cannot log into the ONS 15454.
- Always (Grant Always)—Installs the public-key certificate and does not delete it after the session is over. Cisco recommends this option.
- More Details (View Certificate)—Allows you to view the public-key security certificate.

Step 2 Return to your originating procedure (NTP) or task (DLP).

DLP-G48 Create Login Node Groups

Purpose	This task creates a login node group to display ONS 15454s that have an IP connection but not a data channel connection (DCC) to the login node.
Tools/Equipment	None
Prerequisite Procedures	DLP-G46 Log into CTC, page 2-25
Required/As Needed	As needed
Onsite/Remote	Onsite or remote
Security Level	Provisioning or higher

Step 1 From the Edit menu in node view, choose **Preferences**.

Step 2 Click **Login Node Group** and **Create Group**.

Step 3 Enter a name for the group in the Create Login Group Name dialog box. Click **OK**.

Step 4 In the Members area, type the IP address (or node name) of a node you want to add to the group. Click **Add**. Repeat this step for each node that you want to add to the group.

Step 5 Click **OK**.

The next time you log into an ONS 15454, the login node group will be available in the Additional Nodes list of the Login dialog box. For example, in [Figure 2-2](#), a login node group is created that contains the IP addresses for Nodes 1, 4, and 5. During login, if you choose this group from the Additional Nodes list and Disable Network Discovery is not selected, all nodes in the figure appear. If the login group and Disable Network Discovery are both selected, only Nodes 1, 4, and 5 appear. You can create as many login node groups as you need. The groups are stored in the CTC preferences file and are not visible to other users.

Figure 2-2 Login Node Group

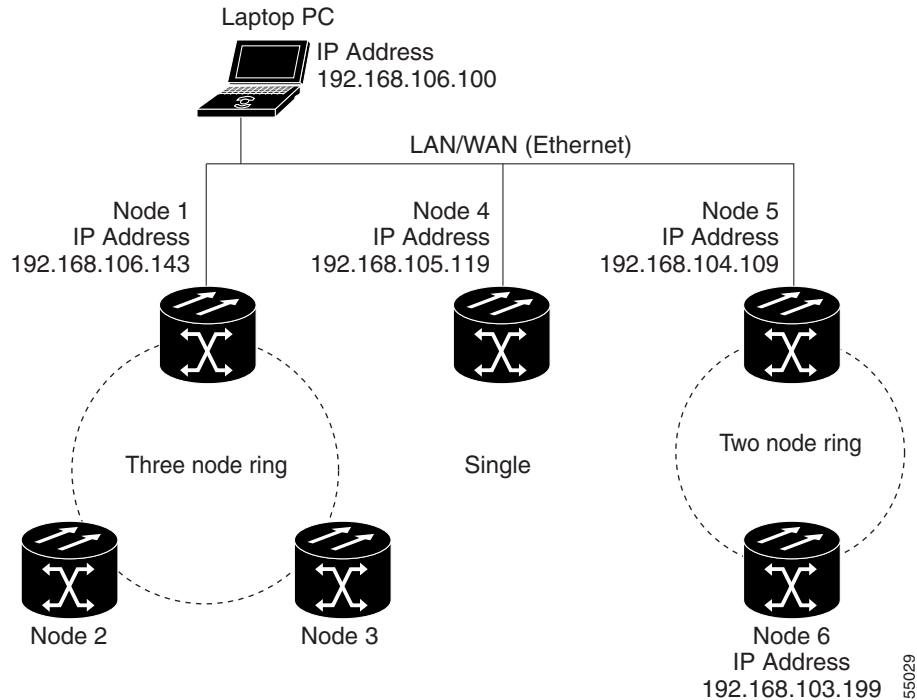

Step 6 Return to your originating procedure (NTP).

DLP-G49 Add a Node to the Current Session or Login Group

Purpose	This task adds a node to the current CTC session or login node group.
Tools	None
Prerequisite Procedures	DLP-G46 Log into CTC, page 2-25
Required/As Needed	As needed
Onsite/Remote	Onsite or remote
Security Level	Provisioning or higher

- Step 1** In any CTC view, from the CTC File menu, click **Add Node**.
- Step 2** In the Add Node dialog box, enter the node name (or IP address).
- Step 3** If you want to add the node to the current login node group, check **Add to current login node group**. Otherwise, leave it unchecked.



Note This check box is active only if you selected a login group when you logged into CTC.

- Step 4** Click **OK**.

After a few seconds, the new node appears on the network view map.

- Step 5** Return to your originating procedure (NTP).
-

DLP-G50 Delete a Node from the Current Session or Login Group

Purpose	This task removes a node from the current CTC session or login node group. To remove a node from a login node group that is not the current one, see “ DLP-G51 Delete a Node from a Specific Login Node Group ” task on page 2-31.
Tools	None
Prerequisite Procedures	DLP-G46 Log into CTC , page 2-25
Required/As Needed	As needed
Onsite/Remote	Onsite or remote
Security Level	Provisioning or higher

- Step 1** From the CTC View menu, choose **Go to Network View**.
- Step 2** On the network map, single-click the node that you want to delete.
- Step 3** From the CTC File menu, click **Delete Selected Node**.
- After a few seconds, the node disappears from the network view map.
- Step 4** Return to your originating procedure (NTP).
-

DLP-G51 Delete a Node from a Specific Login Node Group

Purpose	This task removes a node from a specific login node group. To remove a node from the current login node group, see the “ DLP-G50 Delete a Node from the Current Session or Login Group ” task on page 2-31.
Tools	None
Prerequisite Procedures	DLP-G46 Log into CTC , page 2-25
Required/As Needed	As needed
Onsite/Remote	Onsite or remote
Security Level	Provisioning or higher

- Step 1** In any CTC view, from the CTC Edit menu, choose **Preferences**.
- Step 2** In the Preferences dialog box, click the **Login Node Groups** tab.
- Step 3** Click the login node group tab containing the node you want to remove.
- Step 4** Click the node you want to remove, then click **Remove**.
- Step 5** Click **OK**.

Step 6 Return to your originating procedure (NTP).

DLP-G53 Configure the CTC Alerts Dialog Box for Automatic Popup

Purpose This task sets up the CTC Alerts dialog box to open for all alerts, for circuit deletion errors only, or never. The CTC Alerts dialog box displays network disconnection, Send-PDIP inconsistency, circuit deletion status, condition retrieval errors, and software download failure.

Tools None

Prerequisite Procedures [DLP-G46 Log into CTC, page 2-25](#)

Required/As Needed As needed

Onsite/Remote Onsite or remote

Security Level Provisioning or higher

Step 1 Click the **CTC Alerts** toolbar icon. (The icon is located on the far right of the CTC toolbar.)

Step 2 In the CTC Alerts dialog box, choose one of the following:

- All alerts—Sets the CTC Alerts dialog box to open automatically for all notifications.
- Error alerts only—Sets the CTC Alerts dialog box to open automatically for circuit deletion errors only.
- Never—Sets the CTC Alerts dialog box to never open automatically.

Step 3 Click **Close**.

Step 4 Return to your originating procedure (NTP).



Turn Up a Node

This chapter explains how to provision a single Cisco ONS 15454 dense wavelength division multiplexing (DWDM) node and turn it up for service, including assigning the node name, date, and time; provisioning timing references; provisioning network attributes such as IP address and default router; setting up users and user security; installing cards; and creating DWDM connections.



Note

Procedures in this chapter require that you have a network plan calculated for your DWDM network with Cisco MetroPlanner, Release 7.0. Cisco MetroPlanner is a DWDM planning tool that is available from your Cisco account representative. Cisco MetroPlanner prepares a shelf plan for each network node and calculates the power and attenuation levels for the DWDM cards installed in the node. For information about Cisco MetroPlanner, contact your Cisco account representative. For instructions on using Cisco MetroPlanner, refer to the *Cisco MetroPlanner DWDM Operations Guide, Release 7.0*.



Note

Unless otherwise specified, in this document “ONS 15454” refers to both ANSI (ONS 15454) and ETSI (ONS 15454 SDH) shelf assemblies.



Note

CTC views referenced in these procedures depend on the ONS 15454 mode. In single-shelf mode, the views are network, node, and card. In multishelf mode, the views are network, multishelf, shelf, and card. For more information about CTC views, refer to [Appendix A, “CTC Information and Shortcuts.”](#)

Before You Begin

This section lists the non-trouble procedures (NTPs) needed to turn up a DWDM node. Turn to an NTP for applicable detail-level procedures (DLPs), known as tasks.

1. [NTP-G139 Verify Cisco MetroPlanner Reports and Files, page 3-3](#)—Complete this procedure first.
2. [NTP-G22 Verify Common Card Installation, page 3-4](#)—Complete this procedure next.
3. [NTP-G144 Provision a Multishelf Node, page 3-5](#)—Complete this procedure as needed.
4. [NTP-G23 Create Users and Assign Security, page 3-7](#)—Complete this procedure to create Cisco Transport Controller (CTC) users and assign their security levels.
5. [NTP-G24 Set Up Name, Date, Time, and Contact Information, page 3-10](#)—Continue with this procedure to set the node name, date, time, location, and contact information.

6. [NTP-G25 Set Battery Power Monitor Thresholds, page 3-12](#)—Continue with this procedure to set the node battery power thresholds.
7. [NTP-G26 Set Up CTC Network Access, page 3-13](#)—Continue with this procedure to provision the IP address, default router, subnet mask, and other network configuration settings.
8. [NTP-G27 Set Up the ONS 15454 for Firewall Access, page 3-24](#)—Continue with this procedure if the ONS 15454 will be accessed behind firewalls.
9. [NTP-G132 Provision OSI, page 3-27](#)—Continue with this procedure if the ONS 15454 will be installed in networks with third-party, Open Systems Interconnection (OSI)-based network elements (NEs).
10. [NTP-G28 Set Up SNMP, page 3-36](#)—Complete this procedure if Simple Network Management Protocol (SNMP) will be used for network monitoring.
11. [NTP-G143 Import the Cisco MetroPlanner NE Update Configuration File, page 3-38](#)—Complete this procedure to preprovision the ONS 15454 slots and install the card and automatic node setup (ANS) parameters.
12. [NTP-G30 Install the DWDM Cards, page 3-44](#)—Complete this procedure to install the DWDM cards, including the OSCM, OSC-CSM, 32WSS, 32WSS-L, OPT-BST, OPT-BST-E, OPT-BST-L, OPT-AMP-L, OPT-PRE, 32MUX-O, 32DMX-O, 32DMX, 32DMX-L, 4MD-xx.x, AD-1C-xx.x, AD-2C-xx.x, AD-4C-xx.x, AD-1B-xx.x, AD-4B-xx.x, and MMU.
13. [NTP-G31 Install the DWDM Dispersion Compensating Units, page 3-49](#)—Complete this procedure, as needed, to install a dispersion compensating unit (DCU).
14. [NTP-G32 Install the Transponder and Muxponder Cards, page 3-50](#)—Complete this procedure, as needed, to install transponder (TXP) and muxponder (MXP) cards.
15. [NTP-G123 Install the Filler Cards, page 3-55](#)—Complete this procedure, as needed, to install ONS 15454 filler cards.
16. [NTP-G34 Install Fiber-Optic Cables on DWDM Cards and DCUs, page 3-56](#)—Complete this procedure, as needed, to install the fiber-optic cables on the DWDM cards.
17. [NTP-G140 Install Fiber-Optic Cables Between Terminal, Hub, or ROADM Node DWDM Cards and TXP/MXP Cards, page 3-62](#)—Complete this procedures, as needed, to connect TXP and MXP cards to DWDM cards in a terminal, hub, or ROADM node through the patch panel.
18. [NTP-G191 Install Fiber-Optic Cables on Passthrough ROADM Nodes, page 3-73](#)—Complete this procedures, as needed, to route fiber-optic cables from a 32WSS card in a ROADM node in one shelf to the corresponding 32WSS card in a ROADM node in another shelf. The purpose of this routing is to connect East and West intershelf ROADMs in a passthrough configuration.
19. [NTP-G141 Install Fiber-Optic Cables for Y-Cable Protection Modules, page 3-75](#)—Complete this procedure, as needed, to connect fiber-optic cables to Y-cable modules from client TXP, MXP, and ITU cards.
20. [NTP-G152 Create and Verify Internal Patchcords, page 3-80](#)—Complete this procedure to calculate the DWDM cable connections.
21. [NTP-G37 Run Automatic Node Setup, page 3-82](#)—Complete this procedure next.
22. [NTP-G38 Provision OSC Terminations, page 3-83](#)—Complete this procedure next.
23. [NTP-G39 Verify OSCM Transmit Power, page 3-85](#)—Complete this procedure next.
24. [NTP-G163 Upgrade Nodes in Single-Shelf Mode to Multishelf Mode, page 3-87](#)—Complete this procedure as needed.

NTP-G139 Verify Cisco MetroPlanner Reports and Files

Purpose	This procedure verifies that you have the Cisco MetroPlanner reports and files needed to turn up the node.
Tools/Equipment	None
Prerequisite Procedures	Chapter 1, “Install the Shelf and Common Control Cards”
Required/As Needed	Required
Onsite/Remote	Onsite
Security Level	Retrieve or higher

- Step 1** Verify that you have the Cisco MetroPlanner reports and files shown in [Table 3-1](#) for the node that you will provision. The reports and files can be provided in one of the following ways:
- If you have Cisco MetroPlanner, verify that you have the electronic network design plan from which you can generate the reports in Cisco MetroPlanner. For information about generating the reports, refer to the *Cisco MetroPlanner DWDM Operations Guide*.
 - If you do not have Cisco MetroPlanner, you must have printouts of all reports listed in [Table 3-1](#) except the Assisted Configuration Setup file. Assisted Configuration Setup is an electronic file that will be imported into CTC. You must be able to access it from the CTC computer used to provision the node.

Table 3-1 Cisco MetroPlanner Node Setup Information and Files

Source	Format	Description
Shelf layout	JPG file	Cisco MetroPlanner provides a shelf layout (Figure 3-1) showing the cards that should be installed in each ONS 15454 slot. Cisco MetroPlanner can export this as a JPG file with a user-defined name.
Installation Parameters	Table	Provides the target reference values for the variable optical attenuators (VOAs), output power, optical thresholds, and amplifier configuration parameters.
Internal Connections	Table	Identifies the patchcords that must be installed within the shelf.
NE Update Configuration file	XML file	The Cisco MetroPlanner NE Update configure file is an electronic file with an XML extension and a name assigned by the network designer for the network you are provisioning. The file is imported into CTC where it preprovisions the shelf, configures the OPT-AMP-L card, if present, and configures the Automatic Node Setup (ANS) parameters based on the network calculated by Cisco MetroPlanner.
Traffic Matrix	Table	Shows the traffic flow within the node. During node turn-up, this report is used to identify the location of Y-cable protection groups.
Cable list	Table or list	A list of cables needed to provision the node. The list can be derived from the Internal Connections Report or from the Bill of Materials report prepared by Cisco MetroPlanner.

Figure 3-1 Cisco MetroPlanner Shelf Layout

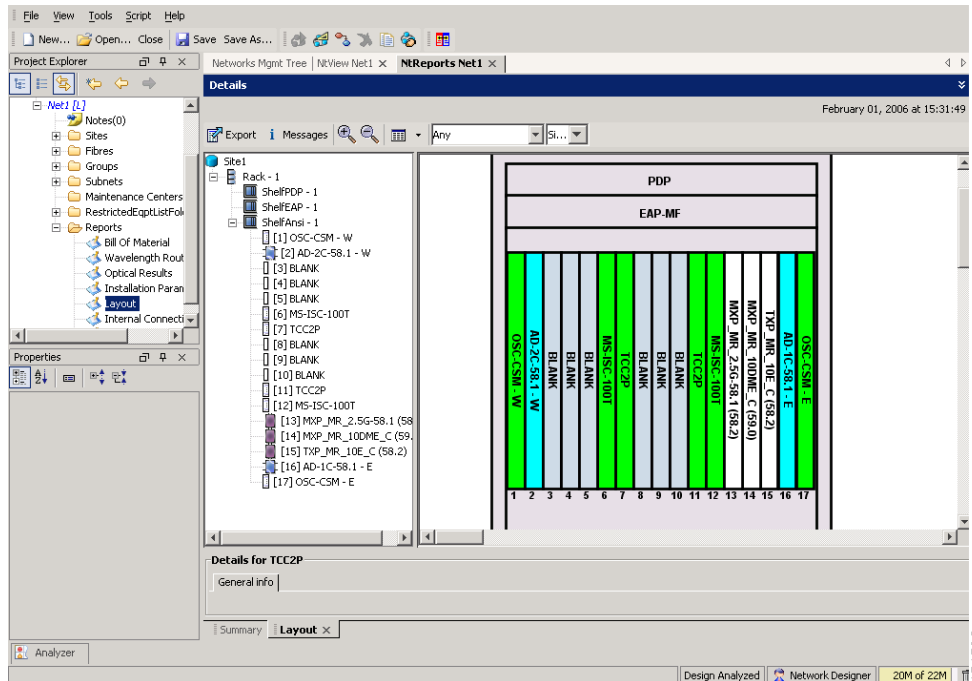

If you do not have all the reports and files listed in [Table 3-1](#), do not continue. See your site or network planner for the required information and files.

- Step 2** Print [Table 3-1](#) for reference. You will need information from the reports during node turn-up.
Stop. You have completed this procedure.

NTP-G22 Verify Common Card Installation

Purpose	This procedure verifies that the ONS 15454 node has two TCC2 or TCC2P cards installed. It also verifies the installation of the AIC-I and MS-ISC-100T cards, if they are installed.
Tools/Equipment	None
Prerequisite Procedures	Chapter 1, “Install the Shelf and Common Control Cards”
Required/As Needed	Required
Onsite/Remote	Onsite
Security Level	Retrieve or higher

- Step 1** Verify that two TCC2 or two TCC2P cards are installed in Slots 7 and 11.
- Step 2** Verify that the FAIL LED is off and the green ACT (active) LED is illuminated on one TCC2 or TCC2P card and the amber STBY (standby) LED is illuminated on the second TCC2 or TCC2P card.



Note If the TCC2/TCC2P cards are not installed, or if their LEDs are not operating as described, do not continue. Repeat the “[DLP-G33 Install the TCC2 or TCC2P Card](#)” task on page 1-73 or refer to the *Cisco ONS 15454 DWDM Troubleshooting Guide* to resolve installation problems before proceeding to [Step 3](#).

Step 3 If the AIC-I card is installed, verify that it is installed in Slot 9 and its ACT (active) LED displays a solid green light.



Note If the AIC-I card is not installed and the card is required by the Cisco MetroPlanner shelf layout, or if it is installed and its LEDs are not operating as described, do not continue. Repeat the “[DLP-G34 Install the AIC-I Card](#)” task on page 1-76 or refer to the *Cisco ONS 15454 DWDM Troubleshooting Guide* to resolve installation problems before proceeding to [Step 4](#).

Step 4 Verify that the software release shown on the LCD matches the software release required for your network. On the LCD, the software release is shown under the platform (Sonet or SDH) and date/temperature. If the release does not match, perform one of the following procedures:

- Perform a software upgrade using a Cisco ONS 15454 software CD or Cisco ONS 15454 SDH software CD. Refer to the release-specific software upgrade document.
- Replace the TCC2/TCC2P cards with cards containing the correct release.

Step 5 If the node will be configured as a multishelf node, verify that redundant MS-ISC-100T cards are installed (Slots 6 and 12 are recommended) and that the green ACT (active) LED is illuminated on both cards.



Note If the MS-ISC-100T card is not installed and the card is required by the Cisco MetroPlanner shelf layout, or if the card’s LEDs are not operating as described, do not continue. Repeat the “[DLP-G309 Install the MS-ISC-100T Card](#)” task on page 1-77 or refer to the *Cisco ONS 15454 DWDM Troubleshooting Guide* to resolve installation problems before proceeding to the next procedure.

Stop. You have completed this procedure.

NTP-G144 Provision a Multishelf Node

Purpose	This procedure provisions a multishelf node from CTC. A multishelf node consists of a control node and subtending shelves that are configured to operate as a single node.
Tools/Equipment	None
Prerequisite Procedures	<p>NTP-G22 Verify Common Card Installation, page 3-4</p> <p>NTP-G145 Connect a Multishelf Node and Subtending Shelves to an MS-ISC-100T Card, page 1-78 or</p> <p>NTP-G158 Connect a Multishelf Node and Subtending Shelves to a Cisco Catalyst 2950, page 1-80</p>

Required/As Needed	As needed
Onsite/Remote	Onsite or remote
Security Level	Superuser

**Caution**

An optical shelf in a multishelf configuration must be provisioned as the node controller shelf and not a subtending shelf, otherwise traffic will be dropped. If no slots are available on an optical shelf to install the MS-ISC-100T cards needed for a node controller shelf, install and configure the Cisco Catalyst 2950. See the “[NTP-G158 Connect a Multishelf Node and Subtending Shelves to a Cisco Catalyst 2950](#)” procedure on page 1-80.

- Step 1** Complete the “[DLP-G46 Log into CTC](#)” task on page 2-25 at the node that you want to configure as a multishelf node.
- Step 2** If you want to configure a shelf as the node controller, continue with [Step 3](#). If you want to configure a shelf as a subtending shelf, continue with [Step 4](#).
- Step 3** To set up the login node as the node controller, complete the following steps:
- In node view (single-node mode) or multishelf view (multishelf mode), click the **Provisioning > General > Multishelf Config** tabs.
 - Click **Enable as Node Controller**.
 - From the LAN Config drop-down list, complete one of the following:
 - Choose **Ethernet Switch** if MS-ISC-100T cards or the Catalyst 2950 switches are already installed and configured.
 - Choose **Stand-Alone** if MS-ISC-100T cards are not installed yet but will be included in the final layout. This option will allow a safe migration of the TCC2/TCC2P card database when the multishelf configuration is complete.
 - Click **Apply**.
 - In the confirmation dialog box, click **Yes** to allow the node to reboot. The CTC view changes to network view and the node icon changes to gray. Wait for the reboot to finish. (This might take several minutes.)
 - After the node reboots, double-click the node. The multishelf view appears.

**Note**

The shelf ID of the node controller is automatically assigned as 1.

- Step 4** To add a node equipped with transponder and muxponder cards as a subtending shelf in the multishelf configuration, complete the following steps:
- In multishelf view, right-click in the white space in the rack and choose **Add Shelf**.
 - In the Shelf ID Selection dialog box, choose a shelf ID (from 2 to 8) from the drop-down list.
 - Click **OK**. The shelf appears in the multishelf view.
 - Disconnect the cross-over (CAT-5) LAN cable from the RJ-45 LAN (TCP/IP) port of the subtending shelf TCC2/TCC2P card in Slot 11.
 - Connect your Windows PC or Solaris workstation NIC to the RJ-45 LAN (TCP/IP) port on the TCC2/TCC2P card in slot 11.
 - Complete the “[DLP-G46 Log into CTC](#)” task on page 2-25 at the subtending shelf.
 - Click the **Provisioning > General > Multishelf Config** tabs.

- h. Click **Enable as Subtended Shelf**.
- i. From the Shelf ID drop-down list, choose the shelf ID that you created in Step b.
- j. Click **Apply**.
- k. In the confirmation dialog box, click **Yes** to reboot the shelf. The CTC view changes to network view and the node icon changes to gray. Wait for the reboot to finish. (This might take several minutes.)
- l. Disconnect your Windows PC or Solaris workstation NIC from the RJ-45 LAN (TCP/IP) port of the subtending shelf TCC2/TCC2P card in Slot 11.
- m. Reconnect the cross-over (CAT-5) LAN cable (disconnected in Step d) to the RJ-45 LAN (TCP/IP) port of the subtending shelf TCC2/TCC2P card in Slot 11.
- n. Repeat Steps a through m to set up additional subtending shelves.

Stop. You have completed this procedure.

NTP-G23 Create Users and Assign Security

Purpose	This procedure creates ONS 15454 users and assigns their security levels.
Tools/Equipment	None
Prerequisite Procedures	NTP-G22 Verify Common Card Installation, page 3-4
Required/As Needed	As needed
Onsite/Remote	Onsite or remote
Security Level	Superuser

- Step 1** Complete the “[DLP-G46 Log into CTC](#)” task on page 2-25 at the node where you need to create users. If you are already logged in, continue with Step 2.



Note You must log in as a Superuser to create additional users. The CISCO15 user provided with each ONS 15454 can be used to set up other ONS 15454 users. You can add up to 500 users to one ONS 15454.

- Step 2** Complete the “[DLP-G54 Create a New User on a Single Node](#)” task on page 3-8 or the “[DLP-G55 Create a New User on Multiple Nodes](#)” task on page 3-9 as needed.



Note You must add the same user name and password to each node a user will access.

- Step 3** If you want to modify the security policy settings, including password aging and idle user timeout policies, complete the “[NTP-G88 Modify Users and Change Security](#)” procedure on page 10-48.

Stop. You have completed this procedure.

DLP-G54 Create a New User on a Single Node

Purpose	This task creates a new user for one ONS 15454.
Tools/Equipment	None
Prerequisite Procedures	DLP-G46 Log into CTC, page 2-25
Required/As Needed	As needed
Onsite/Remote	Onsite or remote
Security Level	Superuser

Step 1 In node view (single-shelf mode) or multishelf view (multishelf mode), click the **Provisioning > Security > Users** tabs.

Step 2 In the Users window, click **Create**.

Step 3 In the Create User dialog box, enter the following:

- **Name**—Type the user name. The name must be a minimum of six and a maximum of 20 alphanumeric (a-z, A-Z, 0-9) characters. For TL1 compatibility, the user name must be 6 to 10 characters.
- **Password**—Type the user password. The password must be a minimum of six and a maximum of 20 alphanumeric (a-z, A-Z, 0-9) and special (+, #, %) characters, where at least two characters are non alphabetic and at least one character is a special character. For TL1 compatibility, the password must be 6 to 10 characters.



Note The password must not contain the user name.

- **Confirm Password**—Type the password again to confirm it.
- **Security Level**—Choose a security level for the user: RETRIEVE, MAINTENANCE, PROVISIONING, or SUPERUSER.



Note Each security level has a different idle time. The idle time is the length of time that CTC can remain idle before the password must be reentered. The defaults are: Retrieve user = unlimited, Maintenance user = 60 minutes, Provisioning user = 30 minutes, and Superuser = 15 minutes. To change the idle times, see the [“NTP-G88 Modify Users and Change Security” procedure on page 10-48](#).

Step 4 Click **OK**.

Step 5 Return to your originating procedure (NTP).

DLP-G55 Create a New User on Multiple Nodes

Purpose	This task adds a new user to multiple ONS 15454 nodes.
Tools/Equipment	None
Prerequisite Procedures	DLP-G46 Log into CTC, page 2-25
Required/As Needed	As needed
Onsite/Remote	Onsite or remote
Security Level	Superuser

Note

All nodes where you want to add users must be accessible in network view.

- Step 1** From the View menu, choose **Go to Network View**.
- Step 2** Click the **Provisioning > Security > Users** tabs.
- Step 3** In the Users window, click **Create**.
- Step 4** In the Create User dialog box, enter the following:
- **Name**—Type the user name. The name must be a minimum of six and a maximum of 20 alphanumeric (a-z, A-Z, 0-9) characters. For TL1 compatibility, the user name must be 6 to 10 characters.
 - **Password**—Type the user password. The password must be a minimum of six and a maximum of 20 alphanumeric (a-z, A-Z, 0-9) and special (+, #, %) characters, where at least two characters are non alphabetic and at least one character is a special character. For TL1 compatibility, the password must be 6 to 10 characters. The password must not contain the user name.
 - **Confirm Password**—Type the password again to confirm it.
 - **Security Level**—Choose a security level for the user: RETRIEVE, MAINTENANCE, PROVISIONING, or SUPERUSER.
-  **Note** Each security level has a different idle time. The idle time is the length of time that CTC can remain idle before it locks up and the password must be reentered. The defaults are: Retrieve user = unlimited, Maintenance user = 60 minutes, Provisioning user = 30 minutes, and Superuser = 15 minutes. To change the idle times, refer to the “[NTP-G88 Modify Users and Change Security](#)” procedure on page 10-48.
- Step 5** In the Select Applicable Nodes area, deselect any nodes where you do not want to add the user (all network nodes are selected by default).
- Step 6** Click **OK**.
- Step 7** In the User Creation Results dialog box, verify that the user was added to all the nodes chosen in [Step 5](#). If not, click **OK** and repeat Steps 2 through 6. If the user was added to all nodes, click **OK** and continue with the next step.
- Step 8** Return to your originating procedure (NTP).

NTP-G24 Set Up Name, Date, Time, and Contact Information

Purpose	This procedure provisions identification information for the node, including the node name, a contact name and phone number, the location of the node, and the date, time, and time zone.
Tools/Equipment	None
Prerequisite Procedures	NTP-G22 Verify Common Card Installation, page 3-4
Required/As Needed	As needed
Onsite/Remote	Onsite or remote
Security Level	Provisioning or higher

-
- Step 1** Complete the [“DLP-G46 Log into CTC” task on page 2-25](#) for the node you will turn up. If you are already logged in, continue with Step 2.
- Step 2** In node view (single-shelf mode) or multishelf view (multishelf mode), click the **Provisioning > General > General** tabs.
- Step 3** In the Node Name field, type a name for the node. For TL1 compliance, names must begin with an alpha character and have no more than 20 alphanumeric (a-z, A-Z, 0-9) characters.



Note To avoid errors when you import the Cisco MetroPlanner configuration file in the [“NTP-G143 Import the Cisco MetroPlanner NE Update Configuration File” task on page 3-38](#), the CTC node name and the Cisco MetroPlanner site name should be the same or at least easy to identify.

- Step 4** (Optional) In the Contact field, type the name of the node contact person and the phone number, up to 255 characters.
- Step 5** (Optional) In the Latitude field, enter the node latitude: N (north) or S (south), degrees, and minutes.
- Step 6** (Optional) In the Longitude field, enter the node longitude: E (east) or W (west), degrees, and minutes. CTC uses the latitude and longitude to position ONS 15454 icons on the network view map. To convert a coordinate in degrees to degrees and minutes, multiply the number after the decimal by 60. For example, the latitude 38.250739 converts to 38 degrees, 15 minutes ($0.250739 \times 60 = 15.0443$, rounded to the nearest whole number).
- Step 7** (Optional) In the Description field, type a description of the node. The description can be a maximum of 255 characters.
- Step 8** (Optional) Check the Use NTP/SNTP Server check box. When checked, CTC uses a Network Time Protocol (NTP) or Simple Network Time Protocol (SNTP) server to set the date and time of the node. Using an NTP or SNTP server ensures that all ONS 15454 network nodes use the same date and time reference. The server synchronizes the node’s time after power outages or software upgrades.
- a. If you check the Use NTP/SNTP Server check box, type the IP address of one of the following:
- An NTP/SNTP server connected to the ONS 15454
 - Another ONS 15454 with NTP/SNTP enabled that is connected to the ONS 15454

**Note**

If you plan to check gateway network element (GNE) for the ONS 15454 SOCKS proxy server (see [“DLP-G56 Provision IP Settings” task on page 3-14](#)), external ONS 15454 nodes must reference the gateway ONS 15454 for NTP/SNTP timing. For more information about the ONS 15454 gateway settings, refer to the “Management Network Connectivity” chapter in the *Cisco ONS 15454 DWDM Reference Manual*.

**Caution**

If you reference another ONS 15454 for the NTP/SNTP server, make sure that the second ONS 15454 references an NTP/SNTP server and not the first ONS 15454 (that is, do not create an NTP/SNTP timing loop by having two ONS 15454 nodes reference each other).

- b. If you did not check Use SNTP/NTP Server, complete the Date and Time fields. The ONS 15454 will use these fields for alarm dates and times. By default, CTC displays all alarms in the CTC computer time zone for consistency. To change the display to the node time zone, complete the [“DLP-G118 Display Alarms and Conditions Using Time Zone” task on page 8-11](#).
 - Date—Type the current date in the format m/d/yyyy, for example, September 24, 2002 is 9/24/2002.
 - Time—Type the current time in the format hh:mm:ss, for example, 11:24:58. The ONS 15454 uses a 24-hour clock, so 10:00 PM is entered as 22:00:00.

Step 9 Click the Time Zone field and choose a city within your time zone from the drop-down list. The list displays the 80 World Time Zones from –11 through 0 (GMT) to +14. Continental United States time zones are GMT-05:00 (Eastern), GMT-06:00 (Central), GMT-07:00 (Mountain), and GMT-08:00 (Pacific).

Step 10 Click the Use Daylight Savings Time check box if the time zone that you chose uses Daylight Savings Time.

**Note**

The Insert AIS-V on STS-1 SD-P and SD-P BER field are not used in DWDM networks.

Step 11 Click **Apply**.

Step 12 In the confirmation dialog box, click **Yes**.

Step 13 Review the node information. If you need to make corrections, repeat Steps 3 through 12 to enter the corrections. If the information is correct, continue with the [“NTP-G25 Set Battery Power Monitor Thresholds” procedure on page 3-12](#).

Stop. You have completed this procedure.

NTP-G25 Set Battery Power Monitor Thresholds

Purpose	This procedure provisions extreme high, extreme low, and low input battery power thresholds within a –48 VDC environment.
Tools/Equipment	None
Prerequisite Procedures	NTP-G22 Verify Common Card Installation, page 3-4
Required/As Needed	Required
Onsite/Remote	Onsite or remote
Security Level	Provisioning or higher

Caution

The default battery power thresholds are normally not changed. Threshold changes should only be performed at the direction of your site administrator.

Note

When the thresholds are crossed, the TCC2/TCC2P card generates warning alarms in CTC. For ONS 15454 power specifications, see the “Hardware Specifications” appendix in the *Cisco ONS 15454 DWDM Reference Manual*.

- Step 1** Complete the [“DLP-G46 Log into CTC” task on page 2-25](#) for the node you will set up. If you are already logged in, continue with Step 2.
- Step 2** In node view (single-shelf mode) or shelf view (multishelf mode), click the **Provisioning > General > Power Monitor** tabs.

Note

In multishelf mode, power monitor thresholds must be provisioned for each shelf within the multishelf including the node controller and all subtending shelves.

- Step 3** To change the extreme low battery voltage threshold in 0.5 VDC increments, choose a voltage from the ELWBATVGVdc drop-down list.
- Step 4** To change the low battery voltage threshold in 0.5 VDC increments, choose a voltage from the LWBATVGVdc drop-down list.
- Step 5** To change the high battery voltage threshold in 0.5 VDC increments, choose a voltage from the HIBATVGVdc drop-down list.
- Step 6** To change the extreme high battery voltage threshold in 0.5 VDC increments, choose a voltage from the EHIBATVGVdc drop-down list.
- Step 7** Click **Apply**.

Stop. You have completed this procedure.

NTP-G26 Set Up CTC Network Access

Purpose	This procedure provisions network access for a node, including its subnet mask, default router, Dynamic Host Configuration Protocol (DHCP) server, Internet Inter-Orb Protocol (IIOP) listener port, gateway settings, static routes, Open Shortest Path First (OSPF) protocol, and Routing Information Protocol (RIP).
Tools/Equipment	None
Prerequisite Procedures	NTP-G22 Verify Common Card Installation, page 3-4
Required/As Needed	Required
Onsite/Remote	Onsite or remote
Security Level	Superuser

-
- Step 1** Complete the [“DLP-G46 Log into CTC” task on page 2-25](#). If you are already logged in, continue with [Step 2](#).
- Step 2** Complete the [“DLP-G56 Provision IP Settings” task on page 3-14](#) to provision the ONS 15454 IP address, subnet mask, default router, DHCP server, IIOP listener port, and SOCKS proxy server settings.



Tip If you cannot log into the node, you can change its IP address, default router, and network mask by using the LCD on the ONS 15454 fan-tray assembly (unless LCD provisioning is suppressed). See the [“DLP-G57 Set the IP Address, Default Router, and Network Mask Using the LCD” task on page 3-16](#) for instructions. However, you cannot use the LCD to provision any other network settings.



Note When accessing CTC from a machine running Windows XP operating system, CTC may sometimes fail to reconnect to a GNE when the GNE proxies for several ENE nodes (approximately 15 ENE nodes). This can happen when there is a side switch or when the LAN is enabled/disabled. This is due to the Windows XP operating system limiting the number of simultaneous TCP/IP connection attempts. As a workaround, relaunch CTC on the GNE node. You can configure a designated socks server list on the CTC to mitigate the problem.

- Step 3** If TCC2P cards are installed and you want to turn on the ONS 15454 secure mode, which allows two IP addresses to be provisioned for the node, complete the [“DLP-G264 Enable Node Security Mode” task on page 3-18](#). Secure mode is not available if TCC2 cards are installed.
- Step 4** If static routes are needed, complete the [“DLP-G58 Create a Static Route” task on page 3-20](#). For more information about static routes, refer to the “Management Network Connectivity” chapter in the *Cisco ONS 15454 DWDM Reference Manual*.
- Step 5** If the ONS 15454 is connected to a LAN or WAN that uses OSPF and you want to share routing information between the LAN or WAN and the ONS network, complete the [“DLP-G59 Set Up or Change Open Shortest Path First Protocol” task on page 3-21](#).
- Step 6** If the ONS 15454 is connected to a LAN or WAN that uses RIP, complete the [“DLP-G60 Set Up or Change Routing Information Protocol” task on page 3-23](#).

Stop. You have completed this procedure.

DLP-G56 Provision IP Settings

Purpose	This task provisions IP settings, which includes the IP address, default router, DHCP access, firewall access, and SOCKS proxy server settings for an ONS 15454 node.
Tools/Equipment	None
Prerequisite Procedures	DLP-G46 Log into CTC, page 2-25
Required/As Needed	Required
Onsite/Remote	Onsite or remote
Security Level	Superuser



Caution

All network changes should be approved by your network (or LAN) administrator.

- Step 1** In node view (single-shelf mode) or multishelf view (multishelf mode), click the **Provisioning > Network > General** tabs.
- Step 2** Complete the following information in the fields listed:
- **IP Address**—Type the IP address assigned to the ONS 15454 node.
 - **Net/Subnet Mask Length**—Type the subnet mask length (decimal number representing the subnet mask length in bits) or click the arrows to adjust the subnet mask length. The subnet mask length is the same for all ONS 15454 nodes in the same subnet.
 - **MAC Address**—(Display only) Displays the ONS 15454 IEEE 802 MAC address.
 - **Default Router**—If the ONS 15454 is connected to a LAN, enter the IP address of the default router. The default router forwards packets to network devices that the ONS 15454 cannot directly access. This field is ignored if any of the following are true:
 - The ONS 15454 is not connected to a LAN.
 - SOCKS proxy server is enabled and the ONS 15454 is provisioned as an end network element (ENE).
 - OSPF (Open Shortest Path First) is enabled on both the ONS 15454 (the OSPF on LAN check box on the Provisioning > Network > OSPF tab) and the LAN where the ONS 15454 is connected.
 - **LCD IP Setting**—Choose one of the following:
 - **Allow Configuration**—Displays the node IP address on the LCD and allows users to change the IP settings using the LCD. This option enables the [“DLP-G57 Set the IP Address, Default Router, and Network Mask Using the LCD”](#) task on page 3-16.
 - **Display Only**—Displays the node IP address on the LCD but does not allow users to change the IP settings using the LCD.
 - **Suppress Display**—Suppresses the node IP address display on the LCD.
 - **Suppress CTC IP Display**—Check this check box if you want to prevent the node IP address from appearing in CTC to users with Provisioning, Maintenance, or Retrieve security levels. (The IP address suppression is not applied to users with Superuser security level.)
 - **Forward DHCP Request To**—Check this check box to enable DHCP. Also, enter the DHCP server IP address in the Request To field. Unchecked is the default. If you will enable any of the gateway settings to implement the ONS 15454 SOCKS proxy server features, leave this field blank.



Note If you enable DHCP, computers connected to an ONS 15454 node can obtain temporary IP addresses from an external DHCP server. The ONS 15454 only forwards DHCP requests; it does not act as a DHCP server.

- Gateway Settings—Provisions the ONS 15454 SOCKS proxy server features. (SOCKS is a standard proxy protocol for IP-based applications.) Do not change these options until you review Scenario 7 in the “Management Network Connectivity” chapter of the *Cisco ONS 15454 DWDM Reference Manual*. In SOCKS proxy server networks, the ONS 15454 is either an ENE, a GNE, or a proxy-only server. Provisioning must be consistent for each NE type.
- Enable SOCKS proxy server on port—If checked, the ONS 15454 serves as a proxy for connections between CTC clients and ONS 15454 nodes that are connected by data communications channels (DCCs) to the proxy ONS 15454. The CTC client establishes connections to DCC-connected nodes through the proxy node. The CTC client does not require IP connectivity to the DCC-connected nodes; it only requires IP connectivity to the proxy ONS 15454. If the Enable SOCKS proxy server on port check box is unchecked, the node does not proxy for any CTC clients. When this box is checked, you can provision one of the following options:
 - External Network Element (ENE)—Choose this option when the ONS 15454 is not connected to a LAN but has DCC connections to other ONS nodes. A CTC computer connected to the ENE through the TCC2/TCC2P card TCP/IP (craft) port can manage nodes that have DCC connections to the ENE. However, the CTC computer does not have direct IP connectivity to these nodes or to any LAN or WAN that those nodes might be connected to.
 - Gateway Network Element (GNE)—Choose this option when the ONS 15454 is connected to a LAN and has DCC connections to other nodes. A CTC computer connected to the LAN can manage all nodes that have DCC connections to the GNE, but the CTC computer does not have direct IP connectivity to them. The GNE option isolates the LAN from the DCC network so that IP traffic originating from the DCC-connected nodes and any CTC computers connected to them is prevented from reaching the LAN.
 - SOCKS proxy only—Choose this option when the ONS 15454 is connected to a LAN and the LAN is separated from the node by a firewall. The SOCKS proxy only option is the same as the GNE option, except that the SOCKS proxy only option does not isolate the DCC network from the LAN.

Step 3 Click **Apply**.

Step 4 Click **Yes** in the confirmation dialog box.

Both TCC2/TCC2P cards reboot, one at a time if changes were made to the IP address, subnet mask, or gateway settings. During this time (approximately 5-6 minutes), the active and standby TCC2/TCC2P card LEDs will blink, turn on, and turn off at different intervals. Eventually, a “Lost node connection, switching to network view” message appears.

Step 5 Click **OK**. The network view appears. The node icon appears in gray, during which time you cannot access the node.

Step 6 Double-click the node icon when it becomes green.

Step 7 Return to your originating procedure (NTP).

DLP-G57 Set the IP Address, Default Router, and Network Mask Using the LCD

Purpose	This task changes the ONS 15454 IP address, default router, and network mask using the LCD on the fan-tray assembly. Use this task if you cannot log into CTC.
Tools/Equipment	None
Prerequisite Procedures	DLP-G33 Install the TCC2 or TCC2P Card, page 1-73
Required/As Needed	As needed
Onsite/Remote	Onsite
Security Level	None

**Note**

You cannot perform this task if the LCD IP Display field on the node view Provisioning > Network tab is set to Display Only or Suppress Display. See the “[DLP-G56 Provision IP Settings](#)” task on page 3-14 to view or change the LCD IP Display field.

**Note**

The LCD reverts to normal display mode after 5 seconds of button inactivity.

Step 1 On the ONS 15454 front panel, repeatedly press the **Slot** button until SHELF on the first line of the LCD appears. You are in the Shelf menu.

Step 2 Repeatedly press the **Port** button until the following information appears:

- To change the node IP address, Node Status=IpAddress ([Figure 3-2](#))
- To change the node network mask, Node Status=Net Mask
- To change the default router IP address, Node Status=Default Rtr

Figure 3-2 *Selecting the IP Address Option*

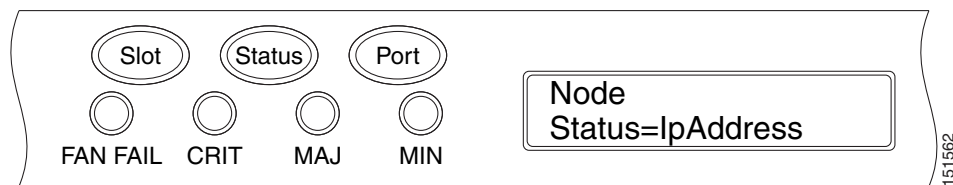

Step 3 Press the **Status** button to display the node IP address ([Figure 3-3](#)), the node subnet mask length, or the default router IP address.

Figure 3-3 *Changing the IP Address*

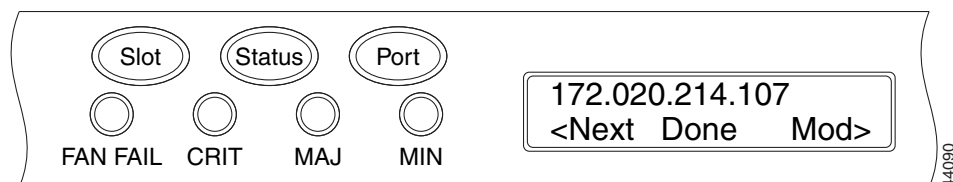

- Step 4** Push the **Slot** button to move to the digit of the IP address, subnet mask, or default router that you want to change. The selected digit flashes.



Tip The Slot, Status, and Port button positions correspond to the positions of the commands shown on the LCD. For example, in [Figure 3-3](#), you press the Slot button to invoke the Next command and the Port button to invoke the Done command.

- Step 5** Press the **Port** button to cycle the IP address, subnet mask, or default router to the correct digit.
- Step 6** When the change is complete, press the **Status** button to return to the relative Node Status menu.
- Step 7** Repeatedly press the **Port** button until the Shelf Save Configuration option appears ([Figure 3-4](#)).

Figure 3-4 Selecting the Save Configuration Option

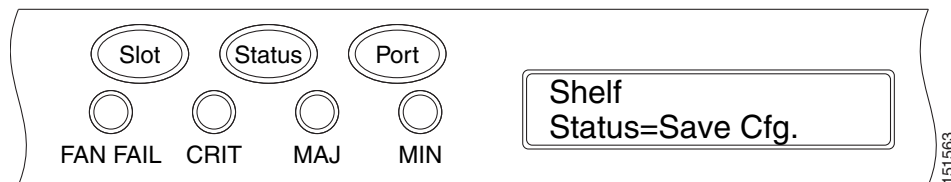

- Step 8** Press the **Status** button to choose the Save Configuration option. A Save and REBOOT message appears ([Figure 3-5](#)).

Figure 3-5 Saving and Rebooting the TCC2/TCC2P

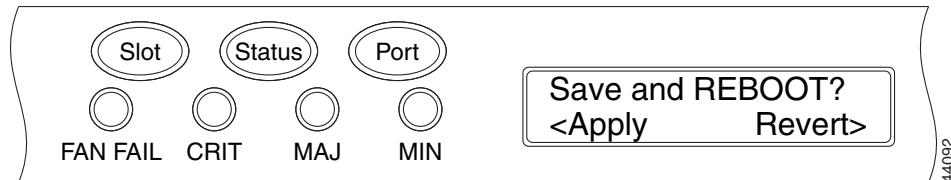

- Step 9** Press the **Slot** button to apply the new IP address, subnet mask, or default router configuration or press **Port** to cancel the configuration.



Note The IP address and default router must be on the same subnet. If not, you cannot apply the configuration.

- Step 10** Saving the new configuration causes the TCC2/TCC2P cards to reboot. During the reboot, a “TCC may Reset” message appears on the LCD. The LCD returns to the normal alternating display after both TCC2 cards or TCC2P cards finish rebooting.
- Step 11** Return to your originating procedure (NTP).

DLP-G264 Enable Node Security Mode

Purpose	This task enables the ONS 15454 security mode. When security mode is enabled, two IP addresses are assigned to the node. One address is assigned to the backplane LAN port and the other to the TCC2P RJ-45 TCP/IP (LAN) port. The TCC2 card does not support security mode.
Tools/Equipment	TCC2P cards must be installed.
Prerequisite Procedures	NTP-G103 Back Up the Database, page 13-2 DLP-G46 Log into CTC, page 2-25
Required/As Needed	As needed
Onsite/Remote	Onsite or remote
Security Level	Superuser

Note

This task requires TCC2P cards. The security mode options described in this task will not appear in CTC if TCC2 cards are installed.

Note

You cannot upgrade a Software Release 7.0 single-shelf node to a multishelf node if the security mode is enabled.

Caution

The IP address assigned to the TCC2P TCP/IP (LAN) port must reside on a different subnet from the backplane LAN port and the ONS 15454 default router. Verify that the new TCC2P IP address meets this requirement and is compatible with ONE 15454 network IP addresses.

Note

The node will reboot after you complete this task, causing a temporary disconnection between the CTC computer and the node.

- Step 1** Click the **Provisioning > Security > Data Comm** tabs.
- Step 2** Click **Change Mode**.
- Step 3** Review the information on the Change Secure Mode page, then click **Next**.
- Step 4** On the TCC Ethernet Port page, enter the IP address and subnet mask for the TCC2P TCP/IP (LAN) port. The IP address cannot reside on the same subnet as the backplane LAN port or the ONS 15454 default router.
- Step 5** Click **Next**.
- Step 6** If needed, on the Backplane Ethernet Port page, modify the backplane IP address, subnet mask, and default router. (You normally do not modify these fields if no ONS 15454 network changes have occurred.)
- Step 7** Click **Next**.
- Step 8** On the SOCKS Proxy Server Settings page, choose one of the following options:

- **External Network Element (ENE)**—If selected, the CTC computer is only visible to the ONS 15454 where the CTC computer is connected. The CTC computer is not visible to the nodes connected to the data communications channel (DCC). In addition, firewall is enabled, which means that the node prevents IP traffic from being routed between the DCC and the LAN port.
- **Gateway Network Element (GNE)**—If selected, the CTC computer is visible to other DCC-connected nodes. The node prevents IP traffic from being routed between the DCC and the LAN port.



Note The SOCKS proxy server is automatically enabled when you enable secure mode.

Step 9 Click **Finish**.

Within the next 30 to 40 seconds, the TCC2P cards reboot. CTC switches to network view, and the CTC Alerts dialog box appears. In network view, the node changes to gray and a DISCONNECTED condition appears in the Alarms tab.

Step 10 In the CTC Alerts dialog box, click **Close**. Wait for the reboot to finish. (This might take several minutes.)

Step 11 After the DISCONNECTED condition clears, complete the following steps to suppress the backplane IP address from appearing in CTC and the LCD. If you do not want to suppress the backplane IP address display, continue with [Step 12](#).

- a. Display the node in node view (single-shelf mode) or multishelf view (multishelf mode).
- b. Click the **Provisioning > Security > Data Comm** tabs.
- c. In the LCD IP Setting field, choose **Suppress Display**. The IP address will not appear on the ONS 15454 LCD.
- d. Check the **Suppress CTC IP Address** check box. The IP address will not appear in the CTC information area or the Provisioning > Security > Data Comm tabs.
- e. Click **Apply**.



Note After you turn on secure mode, the TCC2P IP address becomes the node IP address.

Step 12 Return to your originating procedure (NTP).

DLP-G58 Create a Static Route

Purpose	This task creates a static route to establish CTC connectivity to a computer on another network. This task is performed when one of the following conditions exists: <ul style="list-style-type: none"> • CTC computers on one subnet need to connect to ONS 15454 nodes that are connected by a router to ONS 15454 nodes residing on another subnet. • OSPF is not enabled (OSPF Active on LAN check box on the Provisioning > Network > OSPF tab) and the External Network Element (ENE) gateway setting is not checked. • You need to enable multiple CTC sessions among ONS 15454 nodes residing on the same subnet and the External Network Element (ENE) gateway setting is not checked.
Tools/Equipment	None
Prerequisite Procedures	DLP-G46 Log into CTC, page 2-25
Required/As Needed	As needed.
Onsite/Remote	Onsite or remote
Security Level	Provisioning or higher

-
- Step 1** In node view (single-shelf mode) or multishelf view (multishelf mode), click the **Provisioning > Network** tabs.
- Step 2** Click the **Static Routing** tab. Click **Create**.
- Step 3** In the Create Static Route dialog box, enter the following:
- **Destination**—Enter the IP address of the computer running CTC. To limit access to one computer, enter the full IP address and a subnet mask of 255.255.255.255. To allow access to all computers on the 192.168.1.0 subnet, enter 192.168.1.0 and a subnet mask of 255.255.255.0. You can enter a destination of 0.0.0.0 to allow access to all CTC computers that connect to the router.
 - **Mask**—Enter a subnet mask. If the destination is a host route (that is, one CTC computer), enter a 32-bit subnet mask (255.255.255.255). If the destination is a subnet, adjust the subnet mask accordingly, for example, 255.255.255.0. If the destination is 0.0.0.0, CTC automatically enters a subnet mask of 0.0.0.0 to provide access to all CTC computers. You cannot change this value.
 - **Next Hop**—Enter the IP address of the router port or the node IP address if the CTC computer is connected to the node directly.
 - **Cost**—Enter the number of hops between the ONS 15454 and the computer.
- Step 4** Click **OK**. Verify that the static route appears in the Static Route window.



Note Static route networking examples are provided in “Management Network Connectivity” chapter of the *Cisco ONS 15454 DWDM Reference Manual*.

- Step 5** Return to your originating procedure (NTP).
-

DLP-G59 Set Up or Change Open Shortest Path First Protocol

Purpose	This task enables the OSPF routing protocol on the ONS 15454. Perform this task if you want to include the ONS 15454 in OSPF-enabled networks.
Tools/Equipment	None
Prerequisite Procedures	DLP-G46 Log into CTC, page 2-25 You will need the OSPF Area ID, Hello and Dead intervals, and authentication key (if OSPF authentication is enabled) provisioned on the router to which the ONS 15454 is connected.
Required/As Needed	As needed
Onsite/Remote	Onsite or remote
Security Level	Provisioning or higher

-
- Step 1** In node view (single-shelf mode) or multishelf view (multishelf mode), click the **Provisioning > Network > OSPF** tabs.
- Step 2** On the top left side of the OSPF area, complete the following:
- **DCC/GCC OSPF Area ID Table**—In dotted decimal format, enter the number that identifies the ONS 15454 nodes as a unique OSPF area ID. The Area ID can be any number between 000.000.000.000 and 255.255.255.255, but must be unique to the LAN OSPF area.
 - **SDCC Metric**—This value is normally unchanged. It sets a cost for sending packets across the Section DCC, which is used by OSPF routers to calculate the shortest path. This value should always be higher than the LAN metric. The default SDCC metric is 100.
 - **LDCC Metric**—Sets a cost for sending packets across the Line DCC. This value should always be lower than the SDCC metric. The default LDCC metric is 33. It is usually not changed.
- Step 3** In the OSPF on LAN area, complete the following:
- **OSPF active on LAN**—When checked, enables the ONS 15454 OSPF topology to be advertised to OSPF routers on the LAN. Enable this field on ONS 15454 nodes that directly connect to OSPF routers.
 - **LAN Port Area ID**—Enter the OSPF area ID (dotted decimal format) for the router port where the ONS 15454 is connected. (This number is different from the DCC/GCC OSPF Area ID.)
- Step 4** By default, OSPF is set to No Authentication. If the OSPF router requires authentication, complete the following steps. If not, continue with [Step 5](#).
- Click the **No Authentication** button.
 - In the Edit Authentication Key dialog box, complete the following:
 - **Type**—Choose **Simple Password**.
 - **Enter Authentication Key**—Enter the password.
 - **Confirm Authentication Key**—Enter the same password to confirm it.
 - Click **OK**.
- The authentication button label changes to Simple Password.
- Step 5** Provision the OSPF priority and interval settings.
- The OSPF priority and interval defaults are the defaults most commonly used by OSPF routers. Verify that these defaults match the ones used by the OSPF router where the ONS 15454 is connected.

- Router Priority—Selects the designated router for a subnet.
- Hello Interval (sec)—Sets the number of seconds between OSPF hello packet advertisements sent by OSPF routers. Ten seconds is the default.
- Dead Interval—Sets the number of seconds that will pass while an OSPF router's packets are not visible before its neighbors declare the router down. Forty seconds is the default.
- Transit Delay (sec)—Indicates the service speed. One second is the default.
- Retransmit Interval (sec)—Sets the time that will elapse before a packet is resent. Five seconds is the default.
- LAN Metric—Sets a cost for sending packets across the LAN. This value should always be lower than the SDCC metric. Ten is the default.

Step 6 Under OSPF Area Range Table, create an area range table if one is needed:



Note Area range tables consolidate the information that is outside an OSPF area border. One ONS 15454 in the ONS 15454 OSPF area is connected to the OSPF router. An area range table on this node points the router to the other nodes that reside within the ONS 15454 OSPF area.

- Under OSPF Area Range Table, click **Create**.
- In the Create Area Range dialog box, enter the following:
 - Range Address—Enter the area IP address for the ONS 15454 nodes that reside within the OSPF area. For example, if the ONS 15454 OSPF area includes nodes with IP addresses 10.10.20.100, 10.10.30.150, 10.10.40.200, and 10.10.50.250, the range address would be 10.10.0.0.
 - Range Area ID—Enter the OSPF area ID for the ONS 15454 nodes. This is either the ID in the DCC OSPF Area ID field or the ID in the Area ID for LAN Port field.
 - Mask Length—Enter the subnet mask length. In the Range Address example, this is 16.
 - Advertise—Check if you want to advertise the OSPF range table.
- Click **OK**.

Step 7 All OSPF areas must be connected to Area 0. If the ONS 15454 OSPF area is not physically connected to Area 0, use the following steps to create a virtual link table that will provide the disconnected area with a logical path to Area 0:

- Under OSPF Virtual Link Table, click **Create**.
- In the Create Virtual Link dialog box, complete the following fields. OSPF settings must match OSPF settings for the ONS 15454 OSPF area:
 - Neighbor—The router ID of the Area 0 router.
 - Transit Delay (sec)—The service speed. One second is the default.
 - Hello Int (sec)—The number of seconds between OSPF hello packet advertisements sent by OSPF routers. Ten seconds is the default.
 - Auth Type—If the router where the ONS 15454 is connected uses authentication, choose **Simple Password**. Otherwise, choose **No Authentication**.
 - Retransmit Int (sec)—Sets the time that will elapse before a packet is resent. Five seconds is the default.
 - Dead Int (sec)—Sets the number of seconds that will pass while an OSPF router's packets are not visible before its neighbors declare the router down. Forty seconds is the default.

- c. Click **OK**.
- Step 8** After entering ONS 15454 OSPF area data, click **Apply**.
If you changed the Area ID, the TCC2/TCC2P cards reset, one at a time. The reset takes approximately 10 to 15 minutes.
- Step 9** Return to your originating procedure (NTP).
-

DLP-G60 Set Up or Change Routing Information Protocol

Purpose	This task enables RIP on the ONS 15454. Perform this task if you want to include the ONS 15454 in RIP-enabled networks.
Tools/Equipment	None
Prerequisite Procedures	DLP-G46 Log into CTC, page 2-25 You need to create a static route to the router adjacent to the ONS 15454 for the ONS 15454 to communicate its routing information to non-DCC-connected nodes.
Required/As Needed	As needed
Onsite/Remote	Onsite or remote
Security Level	Provisioning or higher

- Step 1** In node view (single-shelf mode) or multishelf view (multishelf mode), click the **Provisioning > Network > RIP** tabs.
- Step 2** Check the **RIP Active** check box if you are activating RIP.
- Step 3** Choose either RIP Version 1 or RIP Version 2 from the drop-down list, depending on which version is supported in your network.
- Step 4** Set the RIP metric. The RIP metric can be set to a number between 1 and 15 and represents the number of hops.
- Step 5** By default, RIP is set to No Authentication. If the router that the ONS 15454 is connected to requires authentication, complete the following steps. If not, continue with [Step 6](#).
- Click the **No Authentication** button.
 - In the Edit Authentication Key dialog box, complete the following:
 - Type—Choose **Simple Password**.
 - Enter Authentication Key—Enter the password.
 - Confirm Authentication Key—Enter the same password to confirm it.
 - Click **OK**.
- The authentication button label changes to Simple Password.
- Step 6** If you want to complete an address summary, complete the following steps. If not, continue with [Step 7](#). Complete the address summary only if the ONS 15454 is a gateway NE with multiple external ONS 15454 NEs attached with IP addresses in different subnets.
- In the RIP Address Summary area, click **Create**.
 - In the Create Address Summary dialog box, complete the following:

- Summary Address—Enter the summary IP address.
- Mask Length—Enter the subnet mask length using the up and down arrows.
- Hops—Enter the number of hops. The smaller the number of hops, the higher the priority.

c. Click OK.

Step 7 Return to your originating procedure (NTP).

NTP-G27 Set Up the ONS 15454 for Firewall Access

Purpose	This procedure provisions ONS 15454 nodes and CTC computers for access through firewalls.
Tools/Equipment	IIOp listener port number provided by your LAN or firewall administrator
Prerequisite Procedures	NTP-G22 Verify Common Card Installation, page 3-4
Required/As Needed	As needed
Onsite/Remote	Onsite or remote
Security Level	Provisioning or higher

Step 1 Log into a node that is behind the firewall. See the “[DLP-G46 Log into CTC](#)” task on page 2-25 for instructions. If you are already logged in, continue with Step 2.

Step 2 If the ONS 15454 node is in a protected network and CTC computer is an external network, complete the “[DLP-G61 Provision the IIOp Listener Port on the ONS 15454](#)” task on page 3-25.

[Figure 3-6](#) shows ONS 15454 nodes in a protected network and the CTC computer in an external network. For the computer to access the ONS 15454 nodes, you must provision the IIOp listener port specified by your firewall administrator on the ONS 15454.

Figure 3-6 Nodes Behind a Firewall

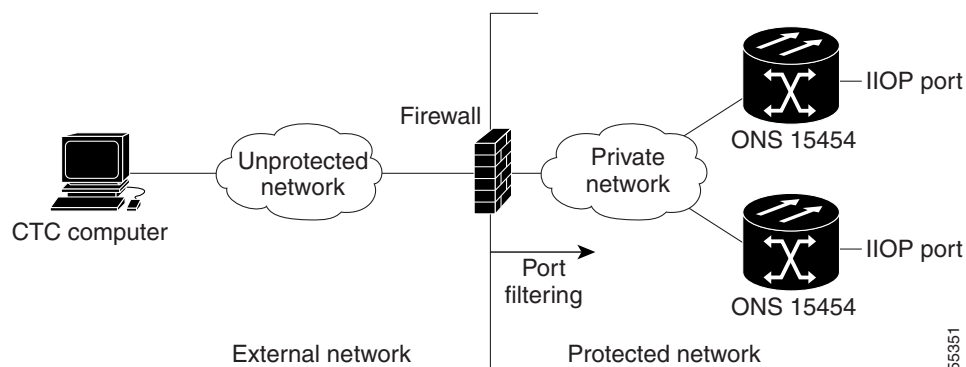

Step 3 If the CTC computer resides behind a firewall, complete the “[DLP-G62 Provision the IIOp Listener Port on the CTC Computer](#)” task on page 3-26.

[Figure 3-7](#) shows a CTC computer and ONS 15454 behind firewalls. For the computer to access the ONS 15454, you must provision the IIOp port on the CTC computer and on the ONS 15454.

Figure 3-7 CTC Computer and ONS 15454 Nodes Residing Behind Firewalls

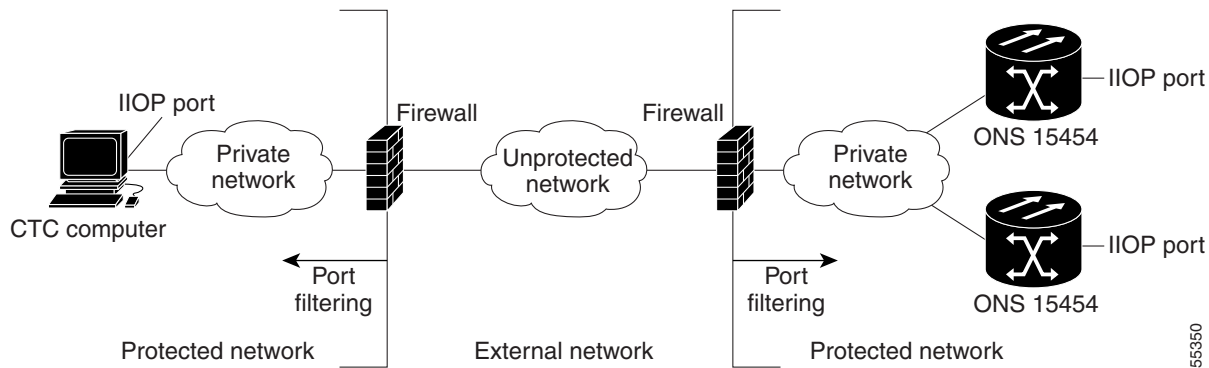

Stop. You have completed this procedure.

DLP-G61 Provision the IIOp Listener Port on the ONS 15454

Purpose	This task sets the IIOp listener port on the ONS 15454, which enables you to access ONS 15454 nodes that reside behind a firewall.
Tools/Equipment	IIOp listener port number provided by your LAN or firewall administrator
Prerequisite Procedures	DLP-G46 Log into CTC, page 2-25
Required/As Needed	As needed
Onsite/Remote	Onsite or remote
Security Level	Provisioning or higher



Note

If the Enable SOCKS proxy on port 1080 check box is checked, CTC will use port 1080 and ignore the configured IIOp port setting. If the check box is later unchecked, the configured IIOp listener port will be used.

- Step 1** In node view (single-shelf mode) or multishelf view (multishelf mode), click the **Provisioning > Security > Access** tabs.
- Step 2** In the TCC CORBA (IIOp) Listener Port area, choose a listener port option:
- **Default - TCC Fixed**—Uses Port 57790 to connect to ONS 15454 nodes on the same side of the firewall or if no firewall is used (default). This option can be used for access through a firewall if Port 57790 is open.
 - **Standard Constant**—Uses Port 683, the CORBA default port number.
 - **Other Constant**—If Port 683 is not used, type the IIOp port specified by your firewall administrator.
- Step 3** Click **Apply**.
- Step 4** When the Change Network Configuration message appears, click **Yes**.
- Both ONS 15454 TCC2/TCC2P cards reboot, one at a time. The reboot takes approximately 15 minutes.

Step 5 Return to your originating procedure (NTP).

DLP-G62 Provision the IIOP Listener Port on the CTC Computer

Purpose	This task selects the IIOP listener port on CTC and must be completed if the computer running CTC resides behind a firewall.
Tools/Equipment	IIOP listener port number from LAN or firewall administrator.
Prerequisite Procedures	NTP-G22 Verify Common Card Installation, page 3-4 DLP-G46 Log into CTC, page 2-25
Required/As Needed	As needed.
Onsite/Remote	Onsite or remote
Security Level	Provisioning or higher

- Step 1** From the Edit menu, choose **Preferences**.
- Step 2** In the Preferences dialog box, click the **Firewall** tab.
- Step 3** In the CTC CORBA (IIOP) Listener Port area, choose a listener port option:
- **Default - Variable**—Use to connect to ONS 15454 nodes from within a firewall or if no firewall is used (default).
 - **Standard Constant**—Use Port 683, the CORBA default port number.
 - **Other Constant**—If Port 683 is not used, enter the IIOP port defined by your administrator.
- Step 4** Click **Apply**. A warning appears telling you that the port change will apply during the next CTC login.
- Step 5** Click **OK**.
- Step 6** In the Preferences dialog box, click **OK**.
- Step 7** To access the ONS 15454 using the IIOP port, log out of CTC then log back in. (To log out, choose **Exit** from the File menu).
- Step 8** Return to your originating procedure (NTP).
-

NTP-G132 Provision OSI

Purpose	This procedure provisions the ONS 15454 so it can be installed in networks with other vendor NEs that use the OSI protocol stack for data communications network (DCN) communications. This procedure provisions the TID Address Resolution Protocol (TARP), OSI routers, manual area addresses, subnetwork points of attachment, and IP-over-CLNS (connectionless network service) tunnels.
Tools/Equipment	None
Prerequisite Procedures	NTP-G15 Install the Common Control Cards, page 1-72
Required/As Needed	As needed
Onsite/Remote	Onsite
Security Level	Provisioning or higher



Caution

This procedure requires an understanding of OSI protocols, parameters, and functions. Before you begin, review the OSI reference sections in the “Management Network Connectivity” chapter of the *Cisco ONS 15454 DWDM Reference Manual* and ensure that you know the role of the ONS 15454 within the OSI and IP network.



Note

This procedure requires provisioning of non-ONS equipment including routers and third party NEs. Do not begin until you have the capability to complete that provisioning.

Step 1 Complete the “[DLP-G46 Log into CTC](#)” task on page 2-25 at the node where you want to provision the OSI. If you are already logged in, continue with Step 2.

Step 2 As needed, complete the following tasks:

- [DLP-G283 Provision OSI Routing Mode, page 3-28](#)—Complete this task first.
- [DLP-G284 Provision the TARP Operating Parameters, page 3-29](#)—Complete this task second.
- [DLP-G285 Add a Static TID to NSAP Entry to the TARP Data Cache, page 3-31](#)—Complete this task as needed.
- [DLP-G287 Add a TARP Manual Adjacency Table Entry, page 3-32](#)—Complete this task as needed.
- [DLP-G288 Provision OSI Routers, page 3-32](#)—Complete this task as needed.
- [DLP-G289 Provision Additional Manual Area Addresses, page 3-33](#)—Complete this task as needed.
- [DLP-G290 Enable the OSI Subnet on the LAN Interface, page 3-34](#)—Complete this task as needed.
- [DLP-G291 Create an IP-Over-CLNS Tunnel, page 3-35](#)—Complete this task as needed.

Stop. You have completed this procedure.

DLP-G283 Provision OSI Routing Mode

Purpose	This task provisions the OSI routing mode. Complete this task when the ONS 15454 is connected to networks with third party NEs that use the OSI protocol stack for DCN communication.
Tools/Equipment	None
Prerequisite Procedures	NTP-G15 Install the Common Control Cards, page 1-72 DLP-G46 Log into CTC, page 2-25
Required/As Needed	As needed
Onsite/Remote	Onsite
Security Level	Provisioning or higher



Caution

Do not complete this task until you confirm the role of the node within the network. It will be either an End System (ES), Intermediate System (IS) Level 1, or IS Level 1/Level 2. This decision must be carefully considered. For additional information about OSI provisioning, refer to the “Management Network Connectivity” chapter of the *Cisco ONS 15454 DWDM Reference Manual*.



Caution

Link State Protocol (LSP) buffers must be the same at all NEs within the network, or loss of visibility might occur. Do not modify the LSP buffers unless you confirm that all NEs within the OSI have the same buffer size.



Caution

LSP buffer sizes cannot be greater than the LAP-D maximum transmission unit (MTU) size within the OSI area.



Note

For ONS 15454 nodes, three virtual routers can be provisioned. The node primary Network Service Access Point (NSAP) address is also the Router 1 primary manual area address. To edit the primary NSAP, you must edit the Router 1 primary manual area address. After you enable Router 1 on the Routers subtab, the Change Primary Area Address button is available to edit the address.

Step 1 In node view (single-shelf mode) or multishelf view (multishelf mode), click the **Provisioning > OSI** tabs.

Step 2 Choose a routing mode:

- End System—The ONS 15454 performs OSI end system (ES) functions and relies upon an intermediate system (IS) for communication with nodes that reside within its OSI area.



Note The End System routing mode is not available if more than one virtual router is enabled.

- Intermediate System Level 1—The ONS 15454 performs OSI IS functions. It communicates with IS and ES nodes that reside within its OSI area. It depends upon an IS L1/L2 node to communicate with IS and ES nodes that reside outside its OSI area.

- Intermediate System Level 1/Level 2—The ONS 15454 performs IS functions. It communicates with IS and ES nodes that reside within its OSI area. It also communicates with IS L1/L2 nodes that reside in other OSI areas. Before choosing this option, verify the following:
 - The node is connected to another IS Level 1/Level 2 node that resides in a different OSI area.
 - The node is connected to all nodes within its area that are provisioned as IS L1/L2.

Step 3 If needed, change the LSP data buffers:

- L1 LSP Buffer Size—Adjusts the Level 1 link state PDU buffer size. The default is 512. It should not be changed.
- L2 LSP Buffer Size—Adjusts the Level 2 link state PDU buffer size. The default is 512. It should not be changed.

Step 4 Return to your originating procedure (NTP).

DLP-G284 Provision the TARP Operating Parameters

Purpose	This task provisions the TARP operating parameters including TARP protocol data unit (PDU) propagation, timers, and loop detection buffer (LDB).
Tools/Equipment	None
Prerequisite procedures	DLP-G46 Log into CTC, page 2-25
Required/As needed	As needed
Onsite/Remote	Onsite or remote
Security Level	Superuser

Step 1 In node view (single-shelf mode) or multishelf view (multishelf mode), click the **Provisioning > OSI > TARP > Config** tabs.

Step 2 Provision the following parameters, as needed:

- TARP PDUs L1 Propagation—If checked (default), TARP Type 1 PDUs that are received by the node and are not excluded by the LDB are propagated to other NEs within the Level 1 OSI area. (Type 1 PDUs request a protocol address that matches a target identifier [TID] within a Level 1 routing area.) The propagation does not occur if the NE is the target of the Type 1 PDU, and PDUs are not propagated to the NE from which the PDU was received.



Note The TARP PDUs L1 Propagation parameter is not used when the Node Routing Area (on the Provisioning > OSI > Main Setup tab) is set to End System.

- TARP PDUs L2 Propagation—If checked (default), TARP Type 2 PDUs that are received by the node and are not excluded by the LDB are propagated to other NEs within the Level 2 OSI areas. (Type 2 PDUs request a protocol address that matches a TID within a Level 2 routing area.) The propagation occurs if the NE is not the target of the Type 2 PDU, and PDUs are not propagated to the NE from which the PDU was received.



Note The TARP PDUs L2 Propagation parameter is only used when the Node Routing Area is provisioned to Intermediate System Level 1/Level 2.

- TARP PDUs Origination—If checked (default), the node performs all TARP origination functions including:
 - TID to NSAP resolution requests (originate TARP Type 1 and Type 2 PDUs)
 - NSAP to TID requests (originate Type 5 PDUs)
 - TARP address changes (originate Type 4 PDUs)



Note TARP Echo and NSAP to TID are not supported.

- TARP Data Cache—If checked (default), the node maintains a TARP data cache (TDC). The TDC is a database of TID to NSAP pairs created from TARP Type 3 PDUs received by the node and modified by TARP Type 4 PDUs (TID to NSAP updates or corrections). TARP 3 PDUs are responses to Type 1 and Type 2 PDUs. The TDC can also be populated with static entries entered on the TARP > Static TDC tab.



Note TARP Data Cache is only used when the TARP PDUs Origination parameter is enabled.

- L2 TARP Data Cache—If checked (default), the TIDs and NSAPs of NEs originating Type 2 requests are added to the TDC before the node propagates the requests to other NEs.



Note The L2 TARP Data Cache parameter is designed for Intermediate System Level 1/Level 2 nodes that are connected to other Intermediate System Level 1/Level 2 nodes. Enabling the parameter for Intermediate System Level 1 nodes is not recommended.

- LDB—If checked (default), enables the TARP loop detection buffer. The LDB prevents TARP PDUs from being sent more than once on the same subnet.



Note The LDB parameter is not used if the Node Routing Mode is provisioned to End System or if the TARP PDUs L1 Propagation parameter is not enabled.

- LAN TARP Storm Suppression—If checked (default), enables TARP storm suppression. This function prevents redundant TARP PDUs from being unnecessarily propagated across the LAN network.
- Send Type 4 PDU on Startup—If checked, a TARP Type 4 PDU is originated during the initial ONS 15454 startup. Type 4 PDUs indicate that a TID or NSAP change has occurred at the NE. (The default setting is not enabled.)
- Type 4 PDU Delay—Sets the amount of time that will pass before the Type 4 PDU is generated when Send Type 4 PDU on Startup is enabled. 60 seconds is the default. The range is 0 to 255 seconds.



Note The Send Type 4 PDU on Startup and Type 4 PDU Delay parameters are not used if TARP PDUs Origination is not enabled.

- LDB Entry—Sets the TARP loop detection buffer timer. The loop detection buffer time is assigned to each LDB entry for which the TARP sequence number (tar-seq) is zero. The default is 5 minutes. The range is 1 to 10 minutes.
- LDB Flush—Sets the frequency period for flushing the LDB. The default is 5 minutes. The range is 0 to 1440 minutes.
- T1—Sets the amount of time to wait for a response to a Type 1 PDU. Type 1 PDUs seek a specific NE TID within an OSI Level 1 area. The default is 15 seconds. The range is 0 to 3600 seconds.
- T2—Sets the amount of time to wait for a response to a Type 2 PDU. TARP Type 2 PDUs seek a specific NE TID value within OSI Level 1 and Level 2 areas. The default is 25 seconds. The range is 0 to 3600 seconds.
- T3—Sets the amount of time to wait for an address resolution request. The default is 40 seconds. The range is 0 to 3600 seconds.
- T4—Sets the amount of time to wait for an error recovery. This timer begins after the T2 timer expires without finding the requested NE TID. The default is 20 seconds. The range is 0 to 3600 seconds.



Note The T1, T2, and T4 timers are not used if TARP PDUs Origination is not enabled.

- Step 3** Click **Apply**.
- Step 4** Return to your originating procedure (NTP).

DLP-G285 Add a Static TID to NSAP Entry to the TARP Data Cache

Purpose	This task adds a static TID to NSAP entry to the TDC. The static entries are required for NEs that do not support TARP and are similar to static routes. For a specific TID, you must force a specific NSAP.
Tools/Equipment	None
Prerequisite procedures	DLP-G46 Log into CTC, page 2-25
Required/As needed	As needed
Onsite/Remote	Onsite or remote
Security Level	Provisioner or higher

- Step 1** In node view (single-shelf mode) or multishelf view (multishelf mode), click the **Provisioning > OSI > TARP > Static TDC** tabs.
- Step 2** Click **Add Static Entry**.
- Step 3** In the Add Static Entry dialog box, enter the following:
- TID—Enter the TID of the NE. (For ONS nodes, the TID is the Node Name parameter on the node or multishelf view Provisioning > General tab.)
 - NSAP—Enter the OSI NSAP address in the NSAP field or, if preferred, click **Use Mask** and enter the address in the Masked NSAP Entry dialog box.
- Step 4** Click **OK** to close the Masked NSAP Entry dialog box, if used, and then click **OK** to close the Add Static Entry dialog box.

Step 5 Return to your originating procedure (NTP).

DLP-G287 Add a TARP Manual Adjacency Table Entry

Purpose	This task adds an entry to the TARP manual adjacency table (MAT). Entries are added to the MAT when the ONS 15454 must communicate across routers or NEs that lack TARP capability.
Tools/Equipment	None
Prerequisite procedures	DLP-G46 Log into CTC, page 2-25
Required/As needed	As needed
Onsite/Remote	Onsite or remote
Security Level	Provisioning or higher

Step 1 In node view (single-shelf mode) or multishelf view (multishelf mode), click the **Provisioning > OSI > TARP > MAT** tabs.

Step 2 Click **Add**.

Step 3 In the Add TARP Manual Adjacency Table Entry dialog box, enter the following:

- **Level**—Sets the TARP Type Code that will be sent:
 - **Level 1**—Indicates that the adjacency is within the same area as the current node. The entry generates Type 1 PDUs.
 - **Level 2**—Indicates that the adjacency is in a different area than the current node. The entry generates Type 2 PDUs.
- **NSAP**—Enter the OSI NSAP address in the NSAP field or, if preferred, click **Use Mask** and enter the address in the Masked NSAP Entry dialog box.

Step 4 Click **OK** to close the Masked NSAP Entry dialog box, if used, and then click **OK** to close the Add Static Entry dialog box.

Step 5 Return to your originating procedure (NTP).

DLP-G288 Provision OSI Routers

Purpose	This task enables an OSI router and edits its primary manual area address.
Tools/Equipment	None
Prerequisite Procedures	NTP-G22 Verify Common Card Installation, page 3-4 DLP-G46 Log into CTC, page 2-25
Required/As Needed	As needed
Onsite/Remote	Onsite or remote
Security Level	Provisioning or higher



Note Router 1 must be enabled before you can enable and edit the primary manual area addresses for Routers 2 and 3.



Note The Router 1 manual area address, System ID, and Selector “00” create the node NSAP address. Changing the Router 1 manual area address changes the node NSAP address.



Note The System ID for Router 1 is the node MAC address. The System IDs for Routers 2 and 3 are created by adding 1 and 2 respectively to the Router 1 System ID. You cannot edit the System IDs.

-
- Step 1** Click the **Provisioning > OSI > Routers > Setup** tabs.
- Step 2** Chose the router you want provision and click **Edit**. The OSI Router Editor dialog box appears.
- Step 3** In the OSI Router Editor dialog box:
- a. Check **Enable Router** to enable the router and make its primary area address available for editing.
 - b. Click the manual area address, then click **Edit**.
 - c. In the Edit Manual Area Address dialog box, edit the primary area address in the Area Address field. If you prefer, click **Use Mask** and enter the edits in the Masked NSAP Entry dialog box. The address (hexadecimal format) can be 8 to 24 alphanumeric characters (0–9, a–f) in length.
 - d. Click **OK** successively to close the following dialog boxes: Masked NSAP Entry (if used), Edit Manual Area Address, and OSI Router Editor.
- Step 4** Return to your originating procedure (NTP).
-

DLP-G289 Provision Additional Manual Area Addresses

Purpose	This task provisions the OSI manual area addresses. One primary area and two additional manual areas can be created for each virtual router.
Tools/Equipment	None
Prerequisite Procedures	NTP-G22 Verify Common Card Installation, page 3-4 DLP-G288 Provision OSI Routers, page 3-32 DLP-G46 Log into CTC, page 2-25
Required/As Needed	As needed
Onsite/Remote	Onsite or remote
Security Level	Provisioning or higher

-
- Step 1** Click the **Provisioning > OSI > Routers > Setup** tabs.
- Step 2** Chose the router where you want provision an additional manual area address and click **Edit**. The OSI Router Editor dialog box appears.

- Step 3** In the OSI Router Editor dialog box:
- Check **Enable Router** to enable the router and make its primary area address available for editing.
 - Click the manual area address, then click **Add**.
 - In the Add Manual Area Address dialog box, enter the primary area address in the Area Address field. If you prefer, click **Use Mask** and enter the address in the Masked NSAP Entry dialog box. The address (hexadecimal format) can be 2 to 24 alphanumeric characters (0–9, a–f) in length.
 - Click **OK** successively to close the following dialog boxes: Masked NSAP Entry (if used), Add Manual Area Address, and OSI Router Editor.
- Step 4** Return to your originating procedure (NTP).
-

DLP-G290 Enable the OSI Subnet on the LAN Interface

Purpose	This task enables the OSI subnetwork point of attachment on the LAN interface.
Tools/Equipment	None
Prerequisite Procedures	NTP-G22 Verify Common Card Installation, page 3-4 DLP-G46 Log into CTC, page 2-25
Required/As Needed	As needed
Onsite/Remote	Onsite or remote
Security Level	Provisioning or higher



Note

When you create communication channels (OSC or GCC), OSI subnetwork points of attachment are enabled on the communication channels. See the “[NTP-G38 Provision OSC Terminations](#)” procedure on page 3-83 and the “[DLP-G76 Provision DCC/GCC Terminations](#)” task on page 7-22.



Note

The OSI subnetwork point of attachment cannot be enabled for the LAN interface if the OSI routing mode is set to ES.



Note

If Secure Mode is on, the OSI Subnet is enabled on the backplane LAN port, not the front TCC2P TCP/IP (LAN) port.

- Step 1** Click the **Provisioning > OSI > Routers > Subnet** tabs.
- Step 2** Click **Enable LAN Subnet**.
- Step 3** In the Enable LAN Subnet dialog box, complete the following fields:
- ESH—Sets the End System Hello (ESH) propagation frequency. An end system NE transmits ESHs to inform other ESs and ISs about the NSAPs it serves. The default is 10 seconds. The range is 10 to 1000 seconds.

- **ISH**—Sets the Intermediate System Hello (ISH) PDU propagation frequency. An intermediate system NE sends ISHs to other ESs and ISs to inform them about the IS NEs it serves. The default is 10 seconds. The range is 10 to 1000 seconds.
- **IIH**—Sets the Intermediate System to Intermediate System Hello (IIH) PDU propagation frequency. The IS-IS Hello PDUs establish and maintain adjacencies between ISs. The default is 3 seconds. The range is 1 to 600 seconds.
- **IS-IS Cost**—Sets the cost for sending packets on the LAN subnet. The IS-IS protocol uses the cost to calculate the shortest routing path. The default IS-IS cost for LAN subnets is 20. It normally should not be changed.
- **DIS Priority**—Sets the designated intermediate system (DIS) priority. In IS-IS networks, one router is elected to serve as the DIS (LAN subnets only). Cisco router DIS priority is 64. For the ONS 15454 LAN subnet, the default DIS priority is 63. It normally should not be changed.

Step 4 Click **OK**.

Step 5 Return to your originating procedure (NTP).

DLP-G291 Create an IP-Over-CLNS Tunnel

Purpose	This task creates an IP-over-Connectionless Network Service (CLNS) tunnel to allow ONS 15454 nodes to communicate across equipment and networks that use the OSI protocol stack.
Tools/Equipment	None
Prerequisite Procedures	NTP-G22 Verify Common Card Installation, page 3-4 DLP-G46 Log into CTC, page 2-25
Required/As Needed	As needed
Onsite/Remote	Onsite or remote
Security Level	Provisioning or higher



Caution

IP-over-CLNS tunnels require two endpoints. You will create one point on an ONS 15454. The other endpoint is generally provisioned on non-ONS equipment including routers and other vendor NEs. Before you begin, verify that you have the capability to create an OSI-over-CLNS tunnel on the other equipment location.

Step 1 Click the **Provisioning > OSI > Tunnels** tabs.

Step 2 Click **Create**.

Step 3 In the Create IP Over CLNS Tunnel dialog box, complete the following fields:

- **Tunnel Type**—Choose a tunnel type:
 - **Cisco**—Creates the proprietary Cisco IP tunnel. Cisco IP tunnels add the CLNS header to the IP packets.
 - **GRE**—Creates a Generic Routing Encapsulation tunnel. GRE tunnels add the CLNS header and a GRE header to the IP packets.

The Cisco proprietary tunnel is slightly more efficient than the GRE tunnel because it does not add the GRE header to each IP packet. The two tunnel types are not compatible. Most Cisco routers support the Cisco IP tunnel, while only a few support both GRE and Cisco IP tunnels. You generally should create Cisco IP tunnels if you are tunneling between two Cisco routers or between a Cisco router and an ONS node.

**Caution**

Always verify that the IP-over-CLNS tunnel type that you choose is supported by the equipment at the other end of the tunnel.

- **IP Address**—Enter the IP address of the IP-over-CLNS tunnel destination.
- **IP Mask**—Enter the IP address subnet mask of the IP-over-CLNS destination.
- **OSPF Metric**—Enter the OSPF metric for sending packets across the IP-over-CLNS tunnel. The OSPF metric, or cost, is used by OSPF routers to calculate the shortest path. The default is 110. Normally, it is not be changed unless you are creating multiple tunnel routes and want to prioritize routing by assigning different metrics.
- **NSAP Address**—Enter the destination NE or OSI router NSAP address.

Step 4 Click **OK**.

Step 5 Provision the other tunnel endpoint using the documentation provided by the manufacturer of the third party vendor NE.

Step 6 Return to your originating procedure (NTP).

NTP-G28 Set Up SNMP

Purpose	This procedure provisions the SNMP parameters so that you can use SNMP management software with the ONS 15454.
Tools/Equipment	None
Prerequisite Procedures	NTP-G22 Verify Common Card Installation, page 3-4
Required/As Needed	Required if SNMP is used at your installation.
Onsite/Remote	Onsite or remote
Security Level	Provisioning or higher

Step 1 Complete the [“DLP-G46 Log into CTC” task on page 2-25](#) at the node where you want to set up SNMP. If you are already logged in, continue with Step 2.

Step 2 In node view (single-shelf mode) or multishelf view (multishelf mode), click the **Provisioning > SNMP** tabs.

Step 3 In the Trap Destinations area, click **Create**.

Step 4 Complete the following in the Create SNMP Trap Destination dialog box ([Figure 3-8](#)):

- **Destination IP Address**—Type the IP address of your network management system (NMS). If the node you are logged into is an ENE, set the destination address to the GNE.
- **Community**—Type the SNMP community name. For a description of SNMP community names, refer to the “SNMP” chapter in the *Cisco ONS 15454 DWDM Reference Manual*.



Note The community name is a form of authentication and access control. The community name assigned to the ONS 15454 is case-sensitive and must match the community name of the NMS.

- UDP Port—The default User Datagram Protocol (UDP) port for SNMP is 162.
- Trap Version—Choose either SNMPv1 or SNMPv2. Refer to your NMS documentation to determine which version to use.

Figure 3-8 Creating an SNMP Trap

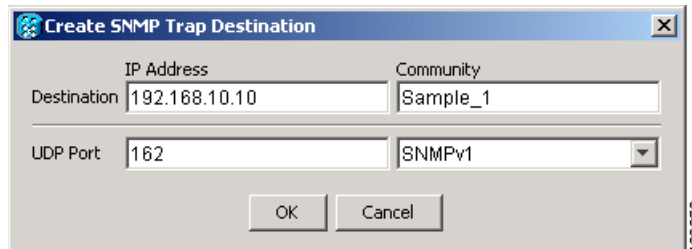

- Step 5** Click **OK**. The node IP address of the node where you provisioned the new trap destination appears in the Trap Destinations area.
- Step 6** Click the node IP address in the Trap Destinations area. Verify the SNMP information that appears in the Selected Destination list.
- Step 7** If you want the SNMP agent to accept SNMP SET requests on certain MIBs, click the **Allow SNMP Sets** check box. If this box is not checked, SET requests are rejected.
- Step 8** If you want to set up the SNMP proxy feature to allow network management, message reporting, and performance statistic retrieval across ONS firewalls, click the **Allow SNMP Proxy** check box located on the SNMP tab.



Note The Use Generic MIB check box is normally not checked for MSTP. It is checked only when the ONS 15454 resides in networks with multiple ONS products, and the network management system requires MIBs with the same name to have the same object IDs. By default, the ONS 15454 uses the CERENT-454-MIBs. Other ONS products, such as the ONS 15600, the ONS 15327, and ONS 15310-CL, use the CERENT-GENERIC-MIBs. If Use Generic MIB is checked, the ONS 15454 will use the CERENT-GENERIC-MIBs so the object IDs will be the same for all products.



Note Using the ONS firewall proxy feature effectively breaches the ONS firewall to exchange management information.

For more information about the SNMP proxy feature, refer to the “SNMP” chapter in the *Cisco ONS 15454 DWDM Reference Manual*.

- Step 9** Click **Apply**.

- Step 10** If you are setting up SNMP proxies, you can set up to three relays that send SNMP trap error counts back to the NE for each trap destination address:
- Click the first trap destination IP address. The address and its community name appear in the Destination fields.
 - Enter up to three SNMP Proxy relay addresses and community names in the fields for Relay A, Relay B, and Relay C.



Note The community names specified for each relay node must match one of the provisioned SNMP community names in the NE.



Note The SNMP proxy directs SNMP traps from this node through IpA to IpB to IpC to the trap destination. Ensure that you enter the IP addresses in the correct order so that this sequence runs correctly.

- Step 11** Click **Apply**.

Stop. You have completed this procedure.

NTP-G143 Import the Cisco MetroPlanner NE Update Configuration File

Purpose	This procedure imports the Cisco MetroPlanner NE Update configuration file. The configuration file, which is provided in XML format, provisions the shelf layout, sets the OPT-AMP-L mode (if present), and installs the automatic node setup (ANS) parameters calculated by Cisco MetroPlanner.
Tools/Equipment	A Cisco MetroPlanner node setup file for the network where the node is installed must be accessible to the CTC computer.
Prerequisite Procedures	NTP-G139 Verify Cisco MetroPlanner Reports and Files, page 3-3
Required/As Needed	Required
Onsite/Remote	Onsite or remote
Security Level	Superuser



Caution

Verify that you have the correct Cisco MetroPlanner network file before you begin this procedure. The file will have an XML extension and a name assigned by your network planner. Check with your network planner or administrator if you have any questions.

- Step 1** Complete the [“DLP-G46 Log into CTC” task on page 2-25](#) at the node where you want to import the Cisco MetroPlanner configuration file. If you are already logged in, continue with [Step 2](#).
- Step 2** If you will choose the Provision Node Layout option to preprovision the cards in the shelf, complete the following steps. If not, continue with [Step 3](#).
- Display the node in node view (single-shelf mode) or multishelf view (multishelf mode).

- b. Verify that two TCC2/TCC2P cards are the only cards installed. If in multishelf mode, verify that each shelf in the multishelf has two TCC2/TCC2P cards.
 - If two TCC2/TCC2P cards are the only cards installed, continue with [Step 3](#).
 - If other cards appear, continue with [Step c](#).
 - c. If a physical card is installed, remove it from the shelf.
 - d. Delete the preprovisioned cards using the “[DLP-G351 Delete a Card in CTC](#)” task on page 3-41, then repeat Steps [a](#) and [b](#).
- Step 3** If you have not created a log file to record the results of the NE update, complete the following steps. If a log file has been created, continue with [Step 4](#),
 - a. Open a text editor or word processing application.
 - b. Create a new text (.TXT) document with a file name of your choosing.
 - c. Save the document in a directory that is easy to navigate to from CTC.
- Step 4** In CTC node view (single-shelf mode) or multishelf view, click the **Provisioning > WDM-ANS > Node Setup** tabs.
- Step 5** In the field under Select XML file, type the path to the Cisco MetroPlanner node setup file containing the parameters for the network where your node resides, or click **Browse** and navigate to the file on your computer or network server. Click the file, then click **Open**. The file will have an XML extension.
- Step 6** In the field under Select Log file, type the path to the text file created in [Step 3](#) where you want the node setup results recorded, or click **Browse** and navigate to the file on your computer or a network server.
-  **Note** Each node setup session overwrites the log file contents. If you want to save the results, save the log file with new name.
-
- Step 7** Click **Apply**. Either the Node Setup Selection for *node name* or Node Setup for *node name* will appear, where *node name* is the name of the node where you are importing the Cisco MetroPlanner configuration file. In a node with multishelf setup containing DWDM units, the top shelf is labeled as *node name_1*. All the other shelves are labelled as *node name_2*, *node name_3* and so on.
 - Step 8** If the Node Setup Selection for *node name* page appears, complete the following steps. If not, continue with [Step 9](#).
 - a. Choose the node profile that you want to apply to the node. The Cisco MetroPlanner XML file contains profiles for all nodes in the network. Choose the profile that applies to the node you are provisioning.
 - b. Click **Next**.
 - Step 9** On the Node Setup for *node name* page, choose one or more of the following:
 - Provision Node Layout—Preprovisions the slots in CTC for the cards required by the network plan. Choose this option when no DWDM cards are installed. (Errors will occur if cards are installed or the slots are preprovisioned.) Preprovisioning the slots before the physical cards are installed ensures that card installers place the cards in the correct slots. Preprovisioning the slots is also useful if you want to set up the network prior to card installation.
 - Provision Card Parameters—This option is available only when an OPT-AMP-L card will be installed. If you check the box, ANS provisions the OPT-AMP-L role, either as an L-band booster amplifier (OPT-LINE) or an L-band preamplifier (OPT-PRE).

- Provision ANS Parameters—If checked, installs the ANS parameters. ANS parameters provision the values required for the node to function within the specified network design. ANS parameters include span losses, optical power, optics thresholds, amplifier working mode, gain, tilt, and many others. Refer to the “Node Reference” chapter in the *Cisco ONS 15454 DWDM Reference Manual* for a list of ONS 15454 ANS parameters.



Note If you are importing the Cisco MetroPlanner configuration file for the first time, you normally choose all three options.

- Skip Interactive Mode—If checked, CTC provisions all the chosen setup components automatically without allowing you to view the results after each one.

Step 10 Click **Next**. The wizard page that appears depends on the options chosen in [Step 9](#):

- If you chose Skip Interactive Mode, continue with [Step 15](#).
- If you chose Provision Node Layout (regardless of whether you chose Provision Card Parameters and/or Provision ANS Parameters), continue with [Step 11](#).
- If you chose Provision Card Parameters, but not Provision Node Layout, continue with [Step 13](#).
- If you chose Provision ANS Parameters, but not Provision Node Layout or Provision ANS Parameters, continue with [Step 14](#).

Step 11 View the cards and slots on the left side of the page and verify that they are the same as the layout in the Cisco MetroPlanner Shelf Layout (see [Table 3-1 on page 3-3](#)). If the cards and slots match, click **Apply**. If not, click **Cancel**, and contact your next level of support to verify that you have the correct node setup file. If the site has a multishelf configuration, click **Next** and repeat this step for each shelf at the site.

CTC preprovisions the slots. (This might take a few seconds.) The results appear in the Log window. Slots that are successfully provisioned display an “Applied” status. A “Slot not empty” status appears if slots cannot be provisioned because a card is physically installed or the slot is already provisioned. If this occurs, complete the following steps. Otherwise, continue with [Step 12](#).

- Click **Cancel**, then click **Yes** at the confirmation. The slot preprovisioning does not revert when you click **Cancel**.
- If a physical card is installed, remove it from the shelf.
- Perform one of the following steps:
 - Delete all the preprovisioned slots using the “DLP-G351 Delete a Card in CTC” task on [page 3-41](#), then repeat Steps 2 through 11.
 - Delete the slot where the Slot Not Empty error occurred using the “DLP-G351 Delete a Card in CTC” task on [page 3-41](#). Complete the “DLP-G353 Preprovision a Single Slot” task on [page 3-42](#) to provision the slot manually, then repeat Steps 2 through 11 making sure to uncheck the Provision Node Layout option in [Step 9](#).



Note When you preprovision a slot, the card is purple in the CTC shelf graphic and an NP (not present) appears on the card. After the physical card is installed, the card changes to white and the NP is removed in the CTC shelf graphic.

Step 12 Choose one of the following steps, based on the choices made in [Step 9](#):

- If you chose Provision Card Parameters with or without Provision ANS Parameters, continue with [Step 13](#).
- If you chose Provision ANS Parameters, but not Provision Card Parameters, continue with [Step 14](#).

- If you chose Provision Node only, continue with [Step 15](#).
- Step 13** Click **Next**. On the Card Parameters page, review the OPT-AMP-L role(s) indicated under the Value column, either PRE_AMPL (L-band optical preamplifier) or BST_AMPL (L band optical booster), then click **Apply**.
- Step 14** If the Provision ANS Parameters box was chosen in [Step 9](#), complete the following steps. If not, continue with [Step 15](#).
- a. Click **Next**.
 - b. Review the ANS parameters on the left half of the page.
 - c. Click **Apply**. The log file will display the results. At the end, a Done status will appear. If a parameter could not be applied, a Setting Refused status appears. If this occurs, contact your next level of support.
- Step 15** Click **Finish**, then click **OK** in the Wizard Complete confirmation dialog box.



Note MS-ISC-100T cards are not provisioned by Cisco MetroPlanner.

Stop. You have completed this procedure.

DLP-G351 Delete a Card in CTC

Purpose	This task deletes a card from an ONS 15454 slot that is provisioned in CTC.
Tools/Equipment	None
Prerequisite Procedures	“DLP-G46 Log into CTC” task on page 2-25
Required/As Needed	As needed
Onsite/Remote	Onsite or remote
Security Level	Superuser

- Step 1** Verify that the following conditions are not present. (During node turn-up, these conditions are normally not present):
- The card is a TCC2/TCC2P card.
 - The card is part of a protection group
 - The card has optical channels or overhead circuits provisioned.
 - The card is being used for timing.
 - The card has an optical service channel (OSC)/generic communications channel (GCC) termination.
- If any of these conditions exist, do not continue. You will not be able to delete the card until the card is removed from protection groups; circuits, DCC, and GCCs are deleted; and a different timing source is provisioned.
- To replace a TCC2/TCC2P card, refer to the *Cisco ONS 15454 DWDM Troubleshooting Guide*.
 - To delete a protection group, see the [“NTP-G83 Modify or Delete Card Protection Settings” procedure on page 10-34](#).

- To delete optical channels see the “[DLP-G347 Delete Optical Channel Client Connections](#)” task on [page 7-8](#) and the “[DLP-G106 Delete Optical Channel Network Connections](#)” task on [page 7-13](#); to delete overhead circuits, see the “[DLP-G112 Delete Overhead Circuits](#)” task on [page 7-29](#).
- To remove the card as a timing source, see the “[NTP-G87 Change Node Timing Parameters](#)” procedure on [page 10-47](#).
- To remove OSC or GCC terminations, see the “[NTP-G85 Modify or Delete OSC Terminations, DCC/GCC Terminations, and Provisionable Patchcords](#)” procedure on [page 10-42](#)

Step 2 On the shelf graphic in CTC, right-click the card that you want to remove and choose **Delete Card**.



Note If you delete a card in CTC but do not remove it from the shelf, it will reboot and reappear in CTC.

Step 3 Return to your originating procedure (NTP).

DLP-G353 Preprovision a Single Slot

Purpose	This procedure preprovisions a single ONS 15454 slot in CTC. Preprovisioning all the slots in the shelf is normally performed when you complete the “ NTP-G143 Import the Cisco MetroPlanner NE Update Configuration File ” procedure on page 3-38 . Use this task if you need to manually preprovision a single slot. All slot preprovisioning must be based upon the Cisco MetroPlanner shelf layout prepared for your site.
Tools/Equipment	Cisco MetroPlanner shelf layout table or JPG file.
Prerequisite Procedures	NTP-G139 Verify Cisco MetroPlanner Reports and Files , page 3-3 DLP-G46 Log into CTC , page 2-25
Required/As Needed	As needed
Onsite/Remote	Onsite or remote
Security Level	Provisioning or higher

Step 1 In node view (single-shelf mode) or multishelf view (multishelf mode), right-click an empty slot where you will install a card.

Step 2 From the Add Card shortcut menu, choose the card type that will be installed based on the Cisco MetroPlanner shelf layout (see [Table 3-1 on page 3-3](#)). Only cards that can be installed in the slot appear in the Add Card shortcut menu. The OPT-AMP-L, 32WSS, 32-MUX-O, and 32-DMX-O cards require two vacant slots, or they will not appear in the shortcut menu. [Table 3-2](#) shows the Add Card shortcut menu items, submenu items, and the card groups and menu options/cards that they reference.

Table 3-2 CTC Add Card Shortcut Menu for DWDM Cards

Menu Item	Submenu Category	Card Group	Submenu item	Card(s)
DWDM	nXP	Transponder and Muxponder	MXPP_MR_2.5G	MXPP_MR_2.5G
			MXP_2.5G_10E	MXP_2.5G_10E MXP_2.5G_10E_C MXP_2.5G_10E_L
			MXP_2.5G_10G	MXP_2.5G_10G
			MXP_MR_10DME	MXP_MR_10DME_C MXP_MR_10DME_L
			MXP_MR_2.5G	MXP_MR_2.5G
			TXPP_MR_2.5G	TXPP_MR_2.5G
			TXP_MR_10E	TXP_MR_10E TXP_MR_10E_C TXP_MR_10E_L
			TXP_MR_10G	TXP_MR_10G
			TXP_MR_2.5G	TXP_MR_2.5G
			MD	Multiplexer and Demultiplexer
	32 DMX L	32DMX-L		
	32 DMXO	32DMX-O		
	32 MUXO	32MUX-O		
	32 WSS	32WSS		
	32 WSS L	32WSS-L		
	4MD	4MD-xx.x		
	OSC	Optical Service Channel	MMU	MMU
			OSC + Combiner/Separator	OSC-CSM
	OADM	Optical Add/Drop Multiplexer	AD-1B	AD-1B-xx.x
			AD-1C	AD-1C-xx.x
			AD-2C	AD-2C-xx.x
			AD-4B	AD-4B-xx.x
			AD-4C	AD-4C-xx.x
	Ampli	Optical Amplifier	OPT-BST	OPT-BST
			OPT-BST E	OPT-BST-E
			OPT-BST L	OPT-BST-L
			OPT-PRE	OPT-PRE
			Optical Amplifier L	OPT-AMP-L

Table 3-2 CTC Add Card Shortcut Menu for DWDM Cards (continued)

Menu Item	Submenu Category	Card Group	Submenu item	Card(s)
Ethernet	—	—	MS-ISC-100T	MS-ISC-100T G1000
OSCM	—	—	—	OSCM (Slots 8 and 10 only)



Note When you preprovision a slot, the card appears purple in the CTC shelf graphic, rather than white when a card is installed in the slot. NP (not present) on the card graphic indicates that the card is not physically installed.

- Step 3** Repeat [Step 2](#) until all the cards shown in the Cisco MetroPlanner shelf layout are provisioned in CTC.
Stop. You have completed this procedure.

NTP-G30 Install the DWDM Cards

Purpose	This procedure describes how to install DWDM cards (OPT-PRE, OPT-BST, OPT-BST-E, OPT-BST-L, OPT-AMP-L, 32MUX-O, 32DMX-O, 32DMX, 32DMX-L, 32WSS, 32WSS-L, MMU, 4MD-xx.x, AD-1C-xx.x, AD-2C-xx.x, AD-4C-xx.x, AD-1B-xx.x, AD-4B-xx.x, OSCM, and OSC-CSM).
Tools/Equipment	<ul style="list-style-type: none"> • Cisco MetroPlanner shelf layout • The following cards, as required by your site plan: OPT-PRE, OPT-BST, OPT-BST-E, OPT-BST-L, OPT-AMP-L, 32MUX-O, 32DMX-O, 32DMX, 32DMX-L, 32WSS, 32WSS-L, MMU, 4MD-xx.x, AD-1C-xx.x, AD-2C-xx.x, AD-4C-xx.x, AD-1B-xx.x, AD-4B-xx.x, OSCM, and OSC-CSM cards (as applicable) • The ONS 15454 NE defaults file if the node will use custom NE defaults
Prerequisite Procedures	NTP-G15 Install the Common Control Cards, page 1-72 NTP-G14 Install DWDM Equipment, page 1-64 NTP-G139 Verify Cisco MetroPlanner Reports and Files, page 3-3 NTP-G143 Import the Cisco MetroPlanner NE Update Configuration File, page 3-38
Required/As Needed	As needed
Onsite/Remote	Onsite
Security Level	Provisioning or higher

**Warning**

This warning symbol means danger. You are in a situation that could cause bodily injury. Before you work on any equipment, be aware of the hazards involved with electrical circuitry and be familiar with standard practices for preventing accidents. To see translations of the warnings that appear in this publication, refer to the **Regulatory Compliance and Safety Information** document for the appropriate Cisco chassis. Statement 274

**Warning**

During this procedure, wear grounding wrist straps to avoid ESD damage to the card. Do not directly touch the backplane with your hand or any metal tool, or you could shock yourself. Statement 94

**Warning**

Class I (CDRH) and Class 1M (IEC) laser products. Statement 1055

**Warning**

Invisible laser radiation may be emitted from the end of the unterminated fiber cable or connector. Do not view directly with optical instruments. Viewing the laser output with certain optical instruments (for example, eye loupes, magnifiers, and microscopes) within a distance of 100 mm may pose an eye hazard. Statement 1056

**Warning**

High-performance devices on this card can get hot during operation. To remove the card, hold it by the faceplate and bottom edge. Allow the card to cool before touching any other part of it or before placing it in an antistatic bag. Statement 201

**Caution**

Always use the supplied ESD wristband when working with a powered ONS 15454. Plug the wristband cable into the ESD jack located on the lower-right outside edge of the shelf assembly.

**Note**

For US installations, complies with the US Federal Drug Administration Code of Federal Regulations Title 21, Sections 1040.10 and 1040.11, except for deviations pursuant to Laser Notice No. 50, dated July 26, 2001.

**Note**

If protective clips are installed on the backplane connectors of the cards, remove the clips before installing the cards.

**Note**

If you install a card incorrectly, the FAIL LED flashes continuously.

Step 1

If the node requires a custom network element (NE) default settings to be installed on the node, complete the “[NTP-G136 Import Network Element Defaults](#)” procedure on page 13-42. If not, continue with [Step 2](#). (For information about the ONS 15454 NE defaults, refer to the “Network Elements Defaults” appendix in the *Cisco ONS 15454 DWDM Reference Manual*.)

**Caution**

If custom NE defaults are required, they must be installed before you install the DWDM cards.

- Step 2** Verify that you have one of the following guides for the DWDM card installation:
- The slots that were preprovisioned when you completed the “[NTP-G143 Import the Cisco MetroPlanner NE Update Configuration File](#)” procedure on page 3-38.
 - The Cisco MetroPlanner shelf layout report (see [Table 3-1 on page 3-3](#)).
- Step 3** If the slots are preprovisioned, continue with [Step 4](#). If you are using the Cisco MetroPlanner shelf layout report, complete the “[DLP-G348 Use the Cisco MetroPlanner Shelf Layout Report](#)” task on page 3-47.
- Step 4** Remove a DWDM card from its packaging, then remove the protective caps from the backplane connectors. (Safety caps are typically yellow.)
- Step 5** Open the card latches/ejectors.
- Step 6** Use the latches/ejectors to firmly slide the card along the slot guide rails until the card plugs into the receptacle at the back of the slot. The correct slot is designated by the Cisco MetroPlanner shelf layout.
- Step 7** Verify that the card is inserted correctly. Simultaneously close the latches/ejectors on the card.

**Note**

It is possible to close the latches/ejectors when the card is not completely plugged in. Ensure that you cannot insert the card any further.

After installing the card, the following LED activity will occur:

- The card’s LEDs will go through a sequence of activities (turn on, turn off, blinking.) This will take 2-3 minutes.
 - The ACT LED turns on.
 - The signal fail (SF) LED might persist until all card ports connect to their far-end counterparts and a signal is present.
- Step 8** If the card does not boot up properly, or the LED activity is not similar to the activity in [Step 7](#), check the following:
- When a physical card type does not match the type of card provisioned for that slot in CTC, the card might not boot. If a DWDM card does not boot, open CTC and ensure that the slot is not provisioned for a different card type before assuming that the card is faulty.
 - If the red FAIL LED does not turn on, check the power.
 - If you insert a card into a slot provisioned for a different card, all LEDs turn off and a minor equipment mismatch alarm appears on the CTC Alarms tab.
 - If the red FAIL LED is on continuously or the LEDs behave erratically, the card is not installed.

If any of conditions are present, remove the card and repeat Steps 4 to 7. If the card does not boot up properly the second time, it might be defective. Contact your next level of support.

- Step 9** Repeat Steps 4 through 8 until all the DWDM cards are installed in the node.
- Step 10** If OPT-PRE cards are installed, complete one of the following steps for each OPT-PRE card based on the Cisco MetroPlanner shelf layout. If OPT-PRE cards are not installed, you have completed this procedure.

- If the Cisco MetroPlanner shelf layout does not include dispersion compensating units (DCUs), install a patchcord and 4-dB attenuator with a tolerance of +/-1 dB between the OPT-PRE DC TX and RX ports for each OPT-PRE card installed in the shelf.
- If the shelf layout includes DCUs, complete the “[NTP-G31 Install the DWDM Dispersion Compensating Units](#)” procedure on page 3-49 for each side of the shelf that requires a DCU.

Stop. You have completed this procedure.

DLP-G348 Use the Cisco MetroPlanner Shelf Layout Report

Purpose	This task describes how to use the Cisco MetroPlanner shelf layout report to install cards in a DWDM node.
Tools/Equipment	None
Prerequisite Procedures	NTP-G139 Verify Cisco MetroPlanner Reports and Files, page 3-3
Required/As Needed	As needed
Onsite/Remote	Onsite
Security Level	Provisioning or higher

-
- Step 1** Display the Cisco MetroPlanner shelf layout report for your site. The report can be viewed in Cisco MetroPlanner (see [Figure 3-9](#)). It can also be viewed as a JPG graphic in a web browser. Refer to the *Cisco MetroPlanner DWDM Operations Guide, Release 7.0* for information about generating shelf layout reports.

Figure 3-9 Cisco MetroPlanner Shelf Layout Report Displayed in Cisco MetroPlanner

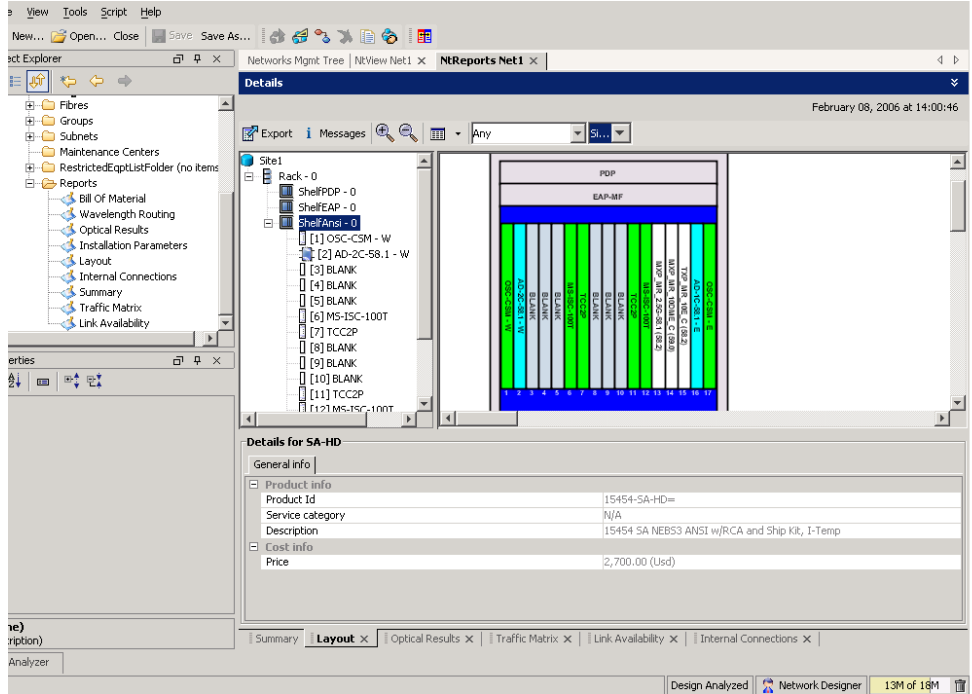
**Step 2** Review the following installation information:

- Rack—Indicates the rack in the node where the cards must be installed.
- Shelf—Indicates the shelf in the rack where the cards must be installed. Shelf options include:
 - Flex Shelf—The ONS 15216 FlexLayer mechanical shelf houses Y-cable modules. Flex shelf positions are numbered 1 to 4 from left to right.
 - DCU Shelf—The Cisco ONS 15216 dispersion compensation shelf assembly houses dispersion compensation units (DCUs). DCU positions are numbered 1 to 2 from left to right.
 - Shelf-ANSI-*n* or Shelf-ETSI-*n*—The ONS 15454 shelf assembly used to house ONS 15454 common, DWDM, and client cards. Positions in this type of shelf are numbered 1 to 17 from left to right. Multiple shelves may appear.
- Slot—Indicates the slot in the specific shelf where the cards must be installed:
 - Unit Name (Product ID)— Identifies the card by its Product ID.
 - Unit Description—Identifies the card by its name.
- Unit Side—Identifies the direction, east or west, that the specific card is serving.
- Unit Plug-in Modules—Identifies the type and number of pluggable port modules (PPMs) that will be used with specific TXP or MXP cards.

Step 3 Return to your originating procedure (NTP).

NTP-G31 Install the DWDM Dispersion Compensating Units

Purpose	This procedure describes how to install the dispersion compensating units (DCUs) for DWDM shelves.
Tools/Equipment	DCUs
Prerequisite Procedures	NTP-G15 Install the Common Control Cards, page 1-72 NTP-G14 Install DWDM Equipment, page 1-64 NTP-G30 Install the DWDM Cards, page 3-44 NTP-G139 Verify Cisco MetroPlanner Reports and Files, page 3-3
Required/As Needed	As needed
Onsite/Remote	Onsite
Security Level	Provisioning or higher



Warning

Class I (CDRH) and Class 1M (IEC) laser products. Statement 1055



Warning

Invisible laser radiation may be emitted from the end of the unterminated fiber cable or connector. Do not view directly with optical instruments. Viewing the laser output with certain optical instruments (for example, eye loupes, magnifiers, and microscopes) within a distance of 100 mm may pose an eye hazard. Statement 1056



Caution

Always use the supplied ESD wristband when working with a powered ONS 15454. Plug the wristband cable into the ESD jack located on the lower-right side of the shelf assembly.



Note

For US installations, complies with the US Federal Drug Administration Code of Federal Regulations Title 21, Sections 1040.10 and 1040.11, except for deviations pursuant to Laser Notice No. 50, dated July 26, 2001.

Step 1

Use both hands to push the DCU all the way into the chassis until the connector spring lock on the right side of the module clicks into place.

Step 2

Open the cover with the laser warning on the connector adapter and then connect the cable connector.



Note

The west DCU is commonly installed on the left side and the east DCU is commonly installed on the right side.



Note

Double-check the placement of the DCU card(s) with your Cisco MetroPlanner shelf layout. If you install the wrong DCU in a slot, remove the DCU and install the correct one.

Stop. You have completed this procedure.

NTP-G32 Install the Transponder and Muxponder Cards

Purpose	This procedure describes how to install the ONS 15454 TXP and MXP cards.
Tools/Equipment	TXP_MR_10G, TXP_MR_10E, TXP_MR_10E_C, TXP_MR_10E_L, TXP_MR_2.5G, TXPP_MR_2.5G, MXP_2.5G_10G, MXP_2.5G_10E, MXP_2.5G_10E_C, MXP_2.5G_10E_L, MXP_MR_2.5G, MXPP_MR_2.5G, MXP_MR_10DME_C, and MXP_MR_10DME_L cards (as applicable)
Prerequisite Procedures	NTP-G15 Install the Common Control Cards, page 1-72 NTP-G14 Install DWDM Equipment, page 1-64 NTP-G139 Verify Cisco MetroPlanner Reports and Files, page 3-3
Required/As Needed	As needed
Onsite/Remote	Onsite
Security Level	None

**Warning**

During this procedure, wear grounding wrist straps to avoid ESD damage to the card. Do not directly touch the backplane with your hand or any metal tool, or you could shock yourself. Statement 94

**Warning**

Class 1 laser product. Statement 1008

**Warning**

Invisible laser radiation may be emitted from the end of the unterminated fiber cable or connector. Do not view directly with optical instruments. Viewing the laser output with certain optical instruments (for example, eye loupes, magnifiers, and microscopes) within a distance of 100 mm may pose an eye hazard. Statement 1056

**Caution**

Always use the supplied ESD wristband when working with a powered ONS 15454. Plug the wristband cable into the ESD jack located on the lower-right outside edge of the shelf assembly.

**Note**

For US installations, complies with the US Federal Drug Administration Code of Federal Regulations Title 21, Sections 1040.10 and 1040.11, except for deviations pursuant to Laser Notice No. 50, dated July 26, 2001.

**Note**

If protective clips are installed on the backplane connectors of the cards, remove the clips before installing the cards.

**Note**

If you install a card incorrectly, the FAIL LED flashes continuously.

- Step 1** Display Cisco MetroPlanner shelf layout (see [Table 3-1 on page 3-3](#)) for the node where you will install the TXP and MXP cards.
- Step 2** Remove the TXP or MXP card from its packaging, then remove the protective clips from the backplane connectors.
- Step 3** Open the card latches/ejectors.
- Step 4** Use the latches/ejectors to firmly slide the TXP or MXP card along the guide rails until the card plugs into the receptacle at the back of the slot designated by the Cisco MetroPlanner shelf layout.
- Step 5** Verify that the card is inserted correctly and simultaneously close the latches/ejectors on the card.



Note It is possible to close the latches and ejectors when the card is not completely plugged into the backplane. Ensure that you cannot insert the card any further.



Note If you install the card in the wrong slot, open the latches, slide the card out, then insert it in the correct slot.

After you install the card, the FAIL, ACT, and SF LEDs will go through a sequence of activities. They will turn on, turn off, and blink at different points. After approximately 2-3 minutes, the ACT or ACT/STBY LED turns on. The SF LED might persist until all card ports connect to their far-end counterparts and a signal is present.



Note Until a TXP or MXP is provisioned, the card is in the standby condition and the ACT/STBY LED remains amber in color.

- Step 6** If the card does not boot up properly or the LEDs do not progress through the activities described in [Step 5](#), check the following:
- When a physical card type does not match the type of card provisioned for that slot in CTC, the card might not boot. If a TXP or MXP card does not boot, open CTC and ensure that the slot is not provisioned for a different card type before assuming that the card is faulty.
 - If the red FAIL LED does not turn on, check the power.
 - If you insert a card into a slot provisioned for a different card, all LEDs turn off.
 - If the red FAIL LED is on continuously or the LEDs behave erratically, the card is not installed properly.
- If any of these conditions are present, remove the card and repeat Steps 3 to 5. If the card does not boot up properly the second time, contact your next level of support.
- Step 7** If the TXP or MXP requires a Small Form-factor Pluggable (SFP or XFP) connector, complete one of the following tasks:
- [DLP-G63 Install an SFP or XFP, page 3-52](#)—Complete this task to install the physical SFP or XFP into the TXP or MXP.
 - [DLP-G273 Preprovision an SFP or XFP Slot, page 3-53](#)—(Optional) Complete this task if you do not have the physical SFP or XFP and need to preprovision the SFP or XFP slot.



Note SFPs/XFPs are hot-swappable input/output devices that plug into a TXP, MXP, or line card port to link the port with the fiber-optic network. For more information about SFPs and XFPs, refer “Hardware Specifications” chapter in the *Cisco ONS 15454 DWDM Reference Manual*, or the *Installing GBIC, SFP and XFP Optics Modules in Cisco ONS 15454, 15454 SDH, 15327, 15600, and 15310-CL Platforms* document available in the ONS 15454 production documentation website on www.cisco.com.



Note Pluggable port module (PPM) provisioning determines how the SFPs and XFPs are used in CTC. PPM provisioning procedures are provided in [Chapter 5, “Provision Transponder and Muxponder Cards.”](#)

Step 8 If you need to remove an SFP or XFP, complete the “[DLP-G64 Remove an SFP or XFP](#)” task on [page 3-54](#).



Note You will provision the TXP and MXP cards after you complete all node turn-up procedures. TXP and MXP provisioning procedures are provided in [Chapter 5, “Provision Transponder and Muxponder Cards.”](#)



Note Until a TXP or MXP is provisioned, the card is in the standby condition and the ACT/STBY LED remains amber in color.

Stop. You have completed this procedure.

DLP-G63 Install an SFP or XFP

Purpose	This task installs SFPs and XFPs into TXP and MXP cards. SFPs and XFPs provide a fiber interface to the card.
Tools/Equipment	None
Prerequisite Procedures	NTP-G32 Install the Transponder and Muxponder Cards, page 3-50
Required/As Needed	As needed
Onsite/Remote	Onsite
Security Level	Provisioning or higher



Note SFPs and XFPs are hot-swappable input/output devices that plug into a TXP, MXP, or line card port to link the port with the fiber-optic network. For more information, refer “Hardware Specifications” chapter in the *Cisco ONS 15454 DWDM Reference Manual*, or the *Installing GBIC, SFP and XFP Optics Modules in Cisco ONS 15454, 15454 SDH, 15327, 15600, and 15310-CL Platforms* document available “Cisco ONS 15454 SONET and DWDM Components Installation” section in the Cisco ONS 15454 documentation website on www.cisco.com.

**Note**

If you install an ONS-XC-10G-L2 XFP in a compatible transponder card (TXP_MR_10E, TXP_MR_10E_C, or TXP_MR_10E_L), you must have the transponder installed only in one of the high-speed slots (6, 7, 12, or 13)

**Note**

SFPs and XFPs are generically called PPMs in CTC. After installing multirate SFPs or XFPs, multirate PPMs must be provisioned in CTC. To complete the provisioning of the pluggable port, complete the [“DLP-G277 Provision a Multirate PPM” task on page 5-6](#).

Step 1 Verify that the SFP or XFP is correct for your network and TXP or MXP card (see the “Card Reference” chapter in the *Cisco ONS 15454 DWDM Reference Manual*). Check that you are installing compatible SFPs or XFPs, for example, SX to SX or LX/LH to LX/LH.

Step 2 Install the SFP or XFP:

- For a mylar tab SFP or XFP: Slide the SFP or XFP into the slot.
- For an actuator/button SFP or XFP: Slide the SFP or XFP all the way into the slot until you hear a click.
- For a bail clasp SFP or XFP: Latch (flip upwards) the bail clasp before inserting the SFP or XFP into the slot and then slide it into the slot.

**Note**

SFP and XFPs are keyed to prevent incorrect installation.

Step 3 Do not remove the protective caps from the SFP or XFP until you are ready to attach the network fiber-optic cable.

Step 4 Return to your originating procedure (NTP).

DLP-G273 Preprovision an SFP or XFP Slot

Purpose	This procedure preprovisions SFPs and XFPs, which connect fiber to TXP and MXP cards. SFPs and XFPs are referred to as pluggable port modules (PPMs) in CTC.
Tools/Equipment	None
Prerequisite Procedures	DLP-G46 Log into CTC, page 2-25
Required/As Needed	As needed
Onsite/Remote	Onsite or remote
Security Level	Provisioning or higher

**Note**

SFPs and XFPs are generically called PPMs in CTC. After installing multirate SFPs or XFPs, multirate PPMs must be provisioned in CTC. To complete the provisioning of the pluggable port, complete the [“DLP-G277 Provision a Multirate PPM” task on page 5-6](#).

-
- Step 1** In node view (single-shelf mode) or shelf view (multishelf mode), double-click the TXP or MXP card where you want to provision PPM settings.
- Step 2** Click the **Provisioning > Pluggable Port Modules** tabs.
- Step 3** In the Pluggable Port Modules area, click **Create**. The Create PPM dialog box appears.
- Step 4** In the Create PPM dialog box, complete the following:
- **PPM**—Choose the slot number where the SFP or XFP is installed from the drop-down list.
 - **PPM Type**—Choose the number of ports supported by your SFP or XFP from the drop-down list. The drop-down list displays the number of PPMs that are available for provisioning. If only one port is supported, **PPM (1 port)** is the only option.
- Step 5** Click **OK**. The newly created port appears in the Pluggable Port Modules pane. The row in the Pluggable Port Modules pane turns light blue. The Actual Equipment Type column remains blank until the actual SFP or XFP is installed. After the SFP or XFP is installed, the row in the pane turns white and the Actual Equipment Type column shows the equipment name.
- Step 6** Verify that the PPM appears in the list in the Pluggable Port Modules pane. If it does not, repeat Steps 3 through 5.
- Step 7** Repeat the task to provision a second PPM, if needed. If not, continue with [Step 8](#).
- Step 8** Click **OK**.
- Step 9** Return to your originating procedure (NTP).
-

DLP-G64 Remove an SFP or XFP

Purpose	This task removes SFPs and XFPs from TXP and MXP cards.
Tools/Equipment	None
Prerequisite Procedures	NTP-G32 Install the Transponder and Muxponder Cards, page 3-50
Required/As Needed	As needed
Onsite/Remote	Onsite
Security Level	Provisioning or higher



Note This task removes the SFP or XFP hardware. To delete the provisioning for an SFP or XFP, see the [“DLP-G280 Delete a PPM” procedure on page 5-12](#).

- Step 1** If a fiber is connected, disconnect the network fiber cable from the SFP or XFP LC-type connector.
- Step 2** Release the SFP or XFP from the slot by performing one of the following actions (depending which latch is on the SFP or XFP):
- For a mylar tab SFP or XFP: Pull out the mylar tab.
 - For an actuator/button SFP or XFP: Press the actuator/button.
 - For a bail clasp SFP or XFP: Unlatch the bail clasp and swing it downward.
- Step 3** Slide the SFP or XFP out of the slot.

Step 4 Return to your originating procedure (NTP).

NTP-G123 Install the Filler Cards

Purpose	This procedure explains how to install the filler cards (blank faceplates) in any unused traffic or AIC-I card slots (Slots 1 through 6, 9, and 11 through 17). The filler card aids in maintaining proper air flow and EMI requirements and is detected by CTC in Software Release 6.0 and higher.
Tools/Equipment	Filler cards (Cisco P/N 15454-FILLER)
Prerequisite Procedures	NTP-G30 Install the DWDM Cards, page 3-44 NTP-G31 Install the DWDM Dispersion Compensating Units, page 3-49 NTP-G32 Install the Transponder and Muxponder Cards, page 3-50
Required/As Needed	As needed
Onsite/Remote	Onsite
Security Level	None



Warning

Blank faceplates (filler panels) serve three important functions: they prevent exposure to hazardous voltages and currents inside the chassis; they contain electromagnetic interference (EMI) that might disrupt other equipment; and they direct the flow of cooling air through the chassis. Do not operate the system unless all cards and faceplates are in place. Statement 156



Caution

Always use the supplied electrostatic discharge (ESD) wristband when working with a powered ONS 15454. Plug the wristband cable into the ESD jack located on the lower right outside edge of the shelf assembly and ensure the shelf assembly is properly grounded.

- Step 1** Open the card ejectors.
- Step 2** Slide the card along the guide rails into the correct slot.
- Step 3** Close the ejectors.
- Step 4** Repeat for any remaining unused card slots.
- Stop. You have completed this procedure.**
-

NTP-G34 Install Fiber-Optic Cables on DWDM Cards and DCUs

Purpose	This procedure attaches fiber-optic cables on the DWDM cards and dispersion compensating units (DCUs).
Tools/Equipment	Fiber-optic cables Cisco MetroPlanner Internal Connections Report
Prerequisite Procedures	NTP-G30 Install the DWDM Cards, page 3-44 NTP-G31 Install the DWDM Dispersion Compensating Units, page 3-49 (as applicable) NTP-G139 Verify Cisco MetroPlanner Reports and Files, page 3-3
Required/As Needed	As needed
Onsite/Remote	Onsite
Security Level	None



Warning

Class I (CDRH) and Class 1M (IEC) laser products. Statement 1055



Note

For US installations, complies with the US Federal Drug Administration Code of Federal Regulations Title 21, Sections 1040.10 and 1040.11, except for deviations pursuant to Laser Notice No. 50, dated July 26, 2001.



Note

In this procedure, you will generally connect fibers in an east-to-west or west-to-east pattern only. “West” refers to cards and ports in Slots 1 through 8. “East” refers to cards and ports installed in Slots 10 through 17.



Note

You will install fiber-optic cables on TXP and MXP cards later in the chapter during the “[NTP-G140 Install Fiber-Optic Cables Between Terminal, Hub, or ROADM Node DWDM Cards and TXP/MXP Cards](#)” procedure on page 3-62.

- Step 1** Refer to the “[DLP-G349 Use the Cisco MetroPlanner Internal Connections Report](#)” task on page 3-58 to complete the remainder of this procedure.
- Step 2** Verify that fibers are available to complete the connections shown in the Cisco MetroPlanner Internal Connections report:
- Count the number of connections listed in the Internal Connections and verify that you have the same number of fibers.
 - Measure the distance between Position 1 and Position 2 for each connection, then verify that the fiber lengths will fit each one.
- Step 3** Complete the “[NTP-G115 Clean Fiber Connectors](#)” procedure on page 13-25 for all fiber connections, even new fiber. Dust particles can degrade performance. Put caps on any fiber connectors that are not used.
- Step 4** On the front of the fiber-storage tray (usually installed below the node you are fiberizing), push the tabs on the left and right sides inward to release the lock on the tray.

- Step 5** Pull the fiber-storage tray away from the shelf until it is fully opened.
- Step 6** Open the fold-down door that is at the bottom of the shelf assembly to expose the cable-routing channel (Figure 3-10).

Figure 3-10 Managing Cables on the Front Panel

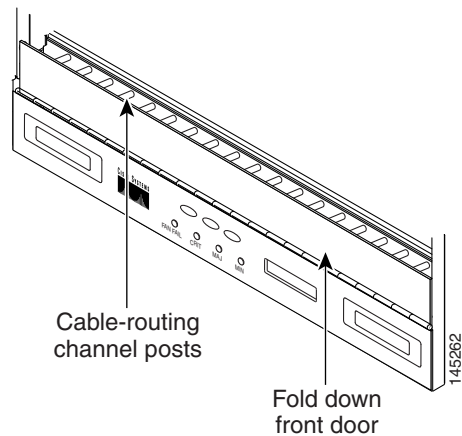

- Step 7** Using one end of the fiber cable into the desired RX port.
- Step 8** Route the fiber cable on the card faceplate through the fiber clip on the faceplate, if provided. (Fiber clips are factory-attached to the faceplates of 32MUX-O, 32DMX, 32DMX-O, OSCM, OSC-CSM, OPT-PRE, OPT-BST, OPT-BST-E, OPT-BST-L, OPT-AMP-L cards.)
- Step 9** Route the fiber cable through the cable-routing channel and cutout on the appropriate side of the shelf assembly, as necessary.
- Step 10** As needed, route slack fiber-optic cable around the round cable retainers in the fiber-storage tray (Figure 3-11).

Figure 3-11 Fiber-Storage Tray

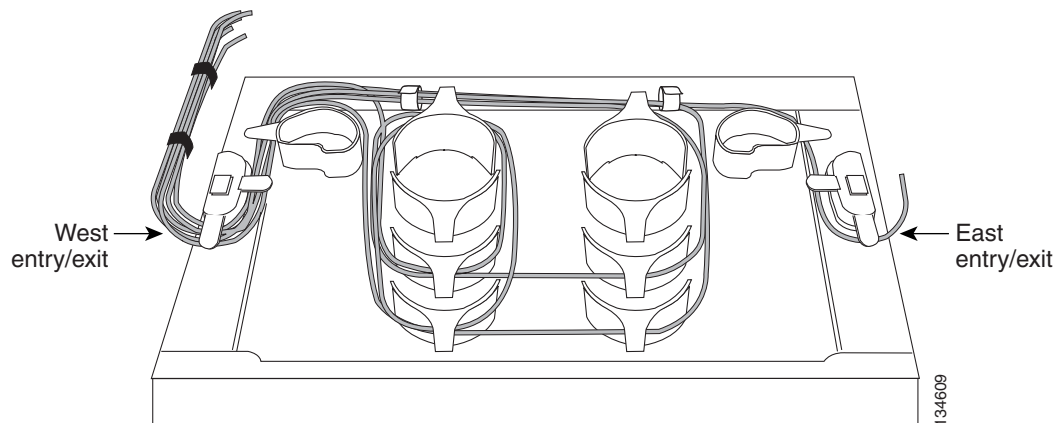

Caution

When you close the fiber-storage tray, the cables must not be pinched, and the cable bend radius must be equal to or greater than the minimum radius that is recommended in your site specifications. As you route each cable through the fiber-storage tray, make sure that adequate cable slack remains.

Step 11 Route the fiber cable out either side of the fiber-storage tray as necessary.

Step 12 Plug the other end of the cable into the desired TX port.



Note Cards display an SF LED after the optical service channel (OSC) terminations are created (see the “[NTP-G38 Provision OSC Terminations](#)” procedure on page 3-83) and transmit and receive fibers are not connected correctly. For example, an RX port is connected to another RX port or a TX port is connected to another TX port.

Step 13 Repeat Steps 4 through 12 until you have connected the intra-shelf fibers according to the Cisco MetroPlanner Internal Connections report.

Step 14 To close the fiber-storage tray, push the tray back toward the rack until it locks into place.

Stop. You have completed this procedure.

DLP-G349 Use the Cisco MetroPlanner Internal Connections Report

Purpose	This task describes how to use the Cisco MetroPlanner Internal Connections report to install cables on the DWDM cards.
Tools/Equipment	None
Prerequisite Procedures	NTP-G139 Verify Cisco MetroPlanner Reports and Files , page 3-3
Required/As Needed	As needed
Onsite/Remote	Onsite
Security Level	Provisioning or higher

Step 1 Display the Cisco MetroPlanner Internal Connections report for the node that you are provisioning. The Internal Connections report is presented in two views, a patchcord installation view and a software provisioning view. [Figure 3-12 on page 3-60](#) shows an example patchcord installation view, and [Figure 3-13 on page 3-60](#) shows an example of a software provisioning view.

The table identifies the patchcords that you must cable by their endpoints. Position 1 identifies the fiber start point; Position 2 indicates the fiber endpoint. The patchcord endpoints are identified by site, slot, and port. Information provided by the Internal Connections report includes:

- **Name**—Displays the name of the site. On the software provisioning view, this column indicates whether you must create the connection manually in CTC. A Yes appearing in this column means that you must create the connection manually.
- **Position-1**—The cable origination in the format is Rack.Shelf.Port. For example, Rack#1.Main Shelf.02 refers to Slot 2 in the main (DWDM) shelf of Rack 1. Refer to the Cisco MetroPlanner Site Dialog for rack and shelf names and locations.
- **Unit-1**—The ONS 15454 DWDM card (unit) that is installed in the Position-1 slot. This is where the patchcord originates.
- **Port#-1**—The port identifier shown in the CTC for the first Position-1 connection.
- **Port ID-1**—(Software provisioning view only) The port identifier shown in TL1 for the Position-1 connection.

- Port Label-1—The name of the physical port printed on the card’s front panel and shown in CTC card view for the Position-1 connection.
- Attenuator—If attenuation is required, the product ID (PID) of the bulk fixed attenuator is shown. “Att-Lpbk-4dB” indicates that the DC TX and DC RX ports on an OPT-PRE card are to be connected with an attenuated loopback that is shipped with the OPT-PRE card. This parameter also indicates when an internal attenuator must be placed between the OPT-PRE DC-TX and DC-RX ports on the when a DCU is equipped.



Note If the Attenuator field is blank, no attenuation is needed.

- Position-2—The cable termination in the format is Rack.Shelf.Port. For example, Rack#1.Main Shelf.02 refers to Slot 2 in the main shelf of Rack 1. Refer to the Cisco MetroPlanner Site Dialog window for rack and shelf names and locations.
- Unit-2—The ONS 15454 DWDM card that is installed in the Position-2 slot. This is where the cabling terminates.
- Port #2—The port identifier shown in CTC for the first Position-2 connection.
- Port ID-2—(Software provisioning view only) The port identifier shown in TL1 for the Position-2 connection.
- Port Label-2—The name of the physical port printed on the card’s front panel and shown in CTC card view for the Position-2 connection.
- P/F—Indicates whether you must create the connection manually in CTC. A Yes appearing in this column means that you must create the connection manually.



Caution

Failure to create the required manual connections will prevent the node from turning up properly.

Figure 3-12 Cisco MetroPlanner Internal Connections Report - Patchcord Installation View

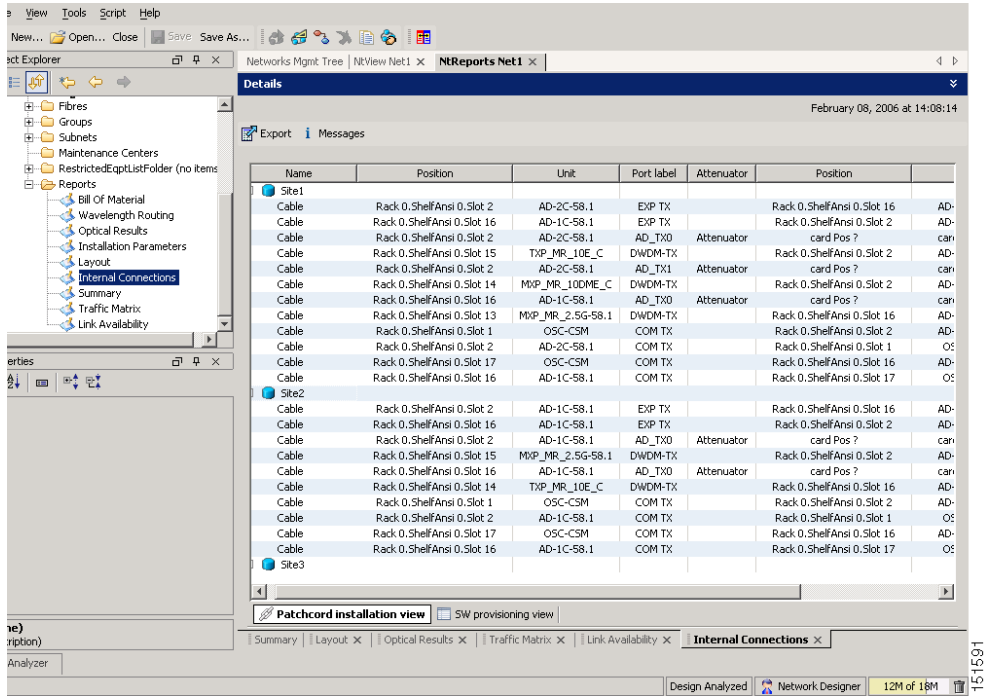
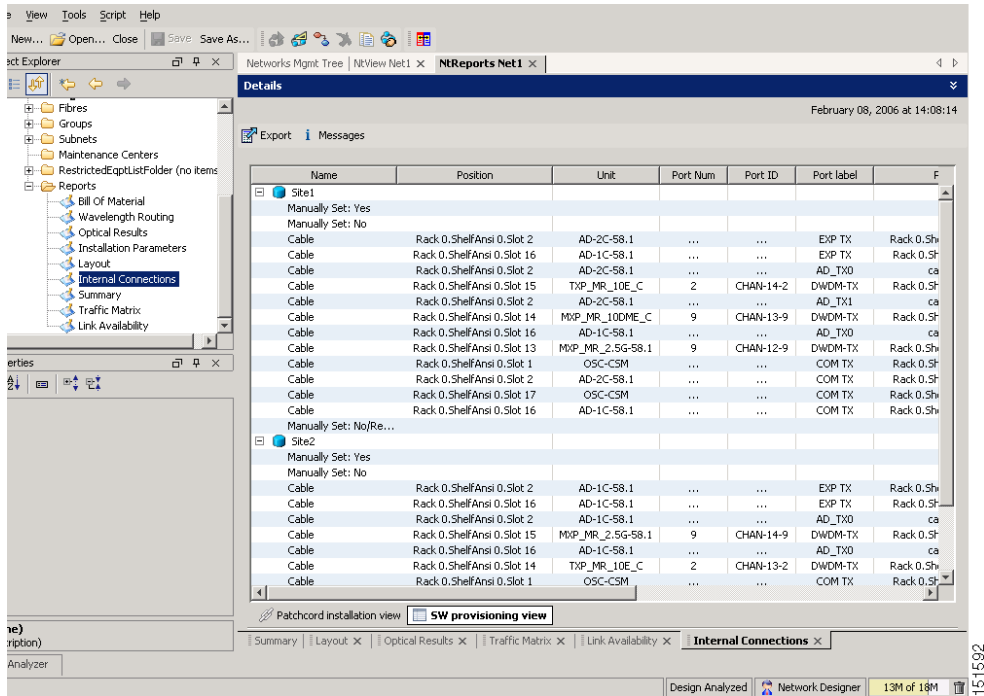

Figure 3-13 Cisco MetroPlanner Internal Connections Report - SW Provisioning View



Step 2 Return to your originating procedure (NTP).

NTP-G140 Install Fiber-Optic Cables Between Terminal, Hub, or ROADM Node DWDM Cards and TXP/MXP Cards

Purpose	This procedure routes fiber-optic cables from 32MUX-O, 32WSS, 32DMX-O, and 32DMX cards in a terminal, hub, or ROADM node to the patch panel, and from the patch panel to TXP/MXP cards.
Tools/Equipment	<p>The following node types require the listed equipment. The cards and patch panels should already be installed before you begin this procedure.</p> <p>Terminal node:</p> <ul style="list-style-type: none"> • One 32DMX-O card • One 32MUX-O card • One standard patch-panel tray; or one deep patch-panel tray • If you are using a standard patch panel, you will also need eight MPO cables: fiber-optic cables, terminated on one end with one multifiber push-on (MPO) connector and on the other end with eight LC-type connectors <p>Hub node:</p> <ul style="list-style-type: none"> • Two 32DMX-O cards • Two 32MUX-O cards • Two standard or two deep patch-panel trays • If you are using standard patch panels, you will also need sixteen MPO cables: fiber-optic cables, terminated on one end with one MPO connector and on the other end with eight LC-type connectors <p>ROADM node:</p> <ul style="list-style-type: none"> • Two 32WSS cards • Two 32DMX cards • Two standard or two deep patch-panel trays • If you are using standard patch panels, you will also need sixteen MPO cables: fiber-optic cables, terminated on one end with one MPO connector and on the other end with eight LC-type connectors <p>Fiber-optic cables, terminated with a single LC-type connector on each end Cisco MetroPlanner Internal Connections Report</p>
Prerequisite Procedures	<p>DLP-G28 Install the Fiber Patch-Panel Tray, page 1-66</p> <p>DLP-G29 Install the Fiber-Storage Tray, page 1-66</p> <p>NTP-G34 Install Fiber-Optic Cables on DWDM Cards and DCUs, page 3-56</p> <p>DLP-G348 Use the Cisco MetroPlanner Shelf Layout Report, page 3-47</p>
Required/As Needed	As needed
Onsite/Remote	Onsite
Security Level	None

-
- Step 1** On the front of the patch-panel tray, push the tabs on the left and right sides inward to release the lock on the tray.
- Step 2** Pull the patch-panel tray away from the shelf until it is fully opened.
- Step 3** Depending on the type of patch-panel tray you are using:
- If you are using the standard patch-panel tray:
 - Complete the “[DLP-G315 Install Fiber-Optic Cables From the 32WSS/32DMX and 32MUX-O/32DMX-O Cards to the Standard Patch-Panel Tray](#)” task on page 3-64.
 - Complete the “[DLP-G316 Install Fiber-Optic Cables from TXP/MXP Cards to the Standard Patch-Panel Tray](#)” task on page 3-68.
 - If you are using the deep patch-panel tray:
 - Complete the “[DLP-G356 Install Fiber-Optic Cables from the 32WSS/32DMX and 32MUX-O/32DMX-O Cards to the Deep Patch-Panel Tray](#)” section on page 3-69.
 - Complete the “[DLP-G357 Install Fiber-Optic Cables from the TXP/MXP Cards to the Deep Patch-Panel Tray](#)” section on page 3-72.
- Step 4** To close the fiber-storage tray, push the tray back toward the rack until it locks into place.
- Stop. You have completed this procedure.**
-

DLP-G315 Install Fiber-Optic Cables From the 32WSS/32DMX and 32MUX-O/32DMX-O Cards to the Standard Patch-Panel Tray

Purpose	This task describes how to route fiber-optic cables from 32MUX-O, 32WSS, 32DMX-O, and 32DMX cards in a terminal, hub, or ROADM node to the standard patch panel.
Tools/Equipment	<p>The following node types require the following equipment. The cards and patch panels should already be installed before you begin this procedure.</p> <p>Terminal node:</p> <ul style="list-style-type: none"> • One 32DMX-O card • One 32MUX-O card • One standard patch-panel tray • Eight fiber-optic MPO cables: each MPO cable is terminated on one end with one multifiber push-on (MPO) connector and on the other end with eight LC-type connectors <p>Hub node:</p> <ul style="list-style-type: none"> • Two 32DMX-O cards • Two 32MUX-O cards • Two standard patch-panel trays • Sixteen fiber-optic MPO cables: each MPO cable is terminated on one end with one multifiber push-on (MPO) connector and on the other end with eight LC-type connectors <p>ROADM node:</p> <ul style="list-style-type: none"> • Two 32WSS cards • Two 32DMX cards • Two standard patch-panel trays • Sixteen fiber-optic MPO cables: each MPO cable is terminated on one end with one multifiber push-on (MPO) connector and on the other end with eight LC-type connectors
Prerequisite Procedures	NTP-G34 Install Fiber-Optic Cables on DWDM Cards and DCUs, page 3-56
Required/As Needed	As needed
Onsite/Remote	Onsite
Security Level	None



Note

For a ROADM or hub node, two patch panels will be used, one for the east side and one for the west. The east side 32WSS/32DMX card will connect to the east patch panel. The west side 32WSS/32DMX card will connect to the west patch panel.

- Step 1** Choose either the east or west side of the shelf to cable the 32MUX-O and 32DMX-O cards (or the 32WSS and 32DMX cards for an ROADM node).

- Step 2** On the patch panel, pull up firmly on the two latches and use them to slide the patch panel up until it snaps in place above the tray (Figure 3-14).

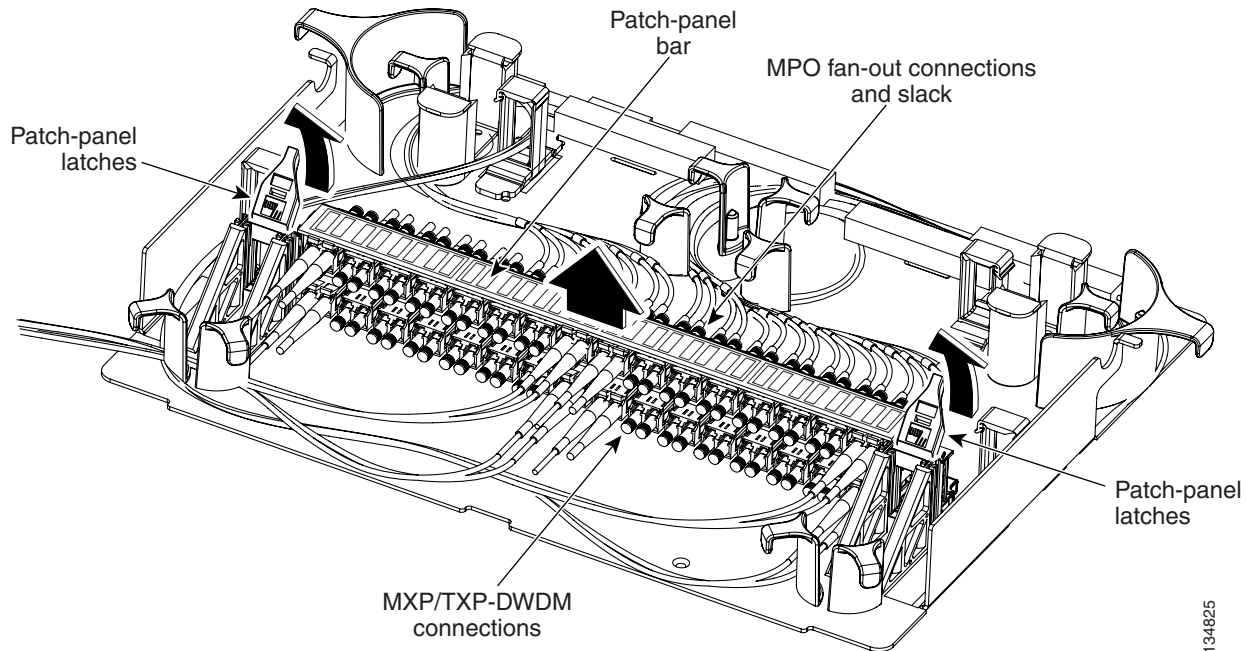
Figure 3-14 Using the Patch-Panel Latches to Slide the Patch Panel Away from the Tray



- Step 3** At the 32WSS or 32MUX-O card in the node, plug the MPO connector of an MPO cable (Figure 3-15) into the top Add RX (30.3–36.6) port of the card. If you are connecting a subsequent MPO cable, plug the MPO connector into the first vacant Add RX card port below the last MPO cable that was installed.

Figure 3-15 MPO Cable

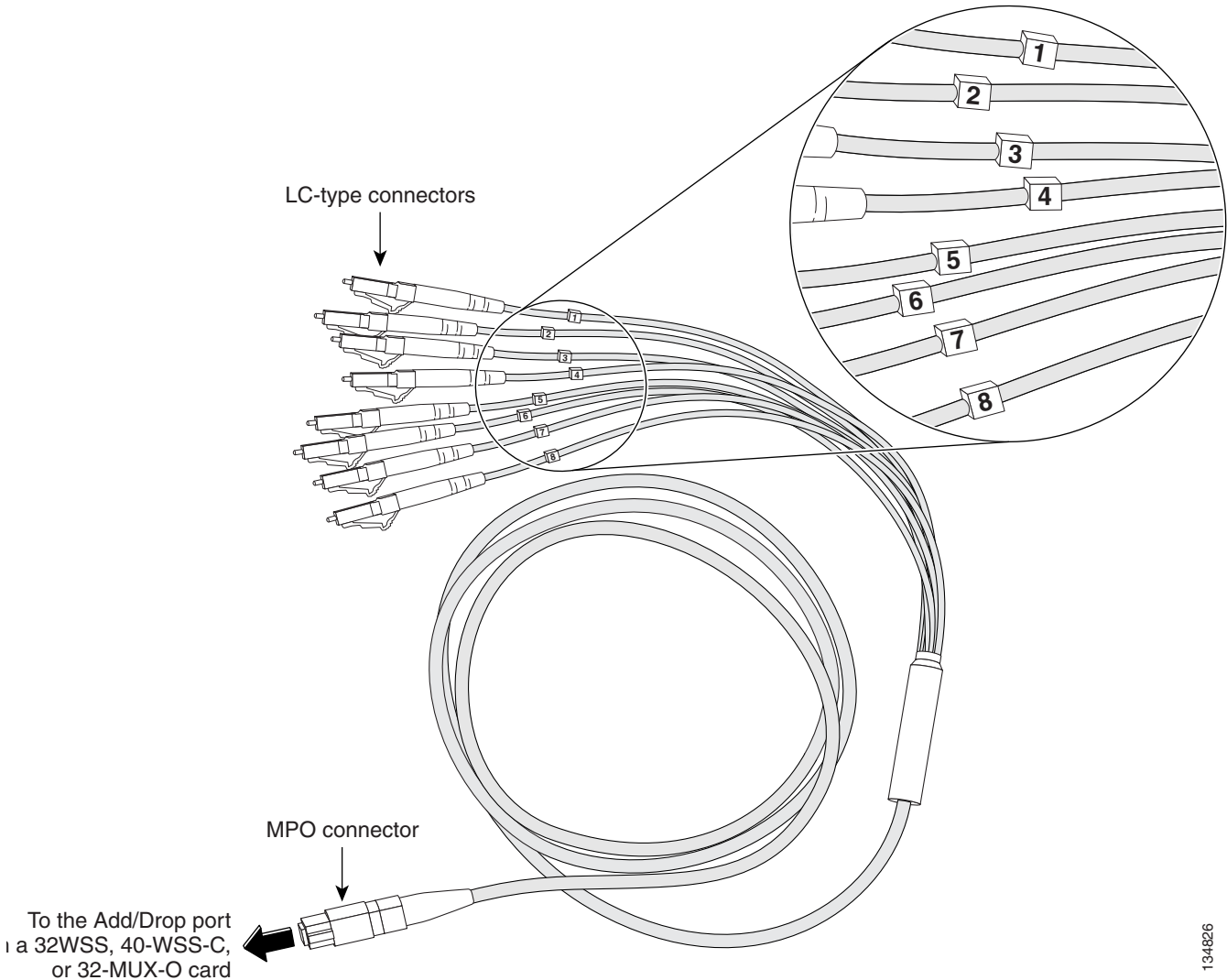

Step 4 Route the MPO cable slack through the patch-panel tray as necessary.



Caution

When you close the patch-panel tray, the cables must not be pinched, and the cable bend radius must be equal to or greater than the minimum radius that is recommended in your site specifications. As you route each cable through the patch-panel tray, make sure that adequate cable slack remains.

Step 5 While facing the front of the patch panel, at the rear side of the patch panel, plug the eight LC-connector fan-out cables on the MPO cable into their corresponding connectors on the bottom row of the patch panel. You should plug the fan-out cables from left to right (as you face the patch panel), following the numbers tagged (1 through 8) on the cables.

Figure 3-16 shows the patch-panel connectors from the rear of the patch-panel tray. Figure 3-17 shows the assigned wavelengths for each port on the patch panel, as indicated at the top of the patch-panel bar. The numbers on the patch-panel bar correspond to a wavelength on the ITU grid.

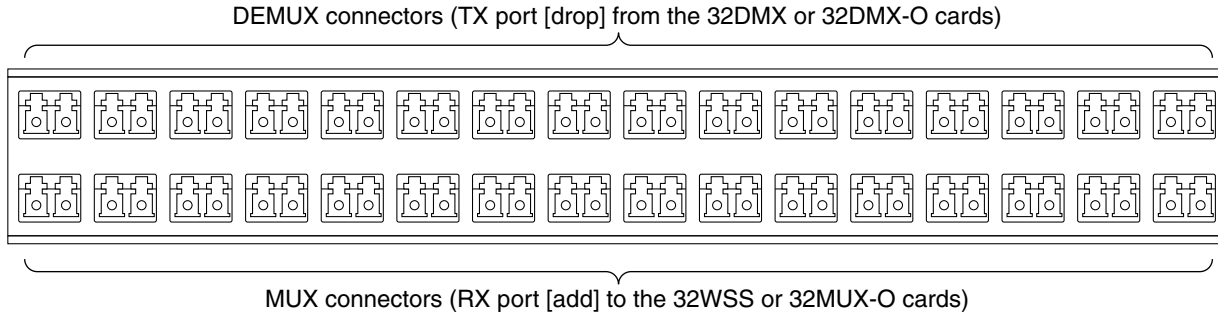
Figure 3-16 Rear View of the Patch Panel

134882

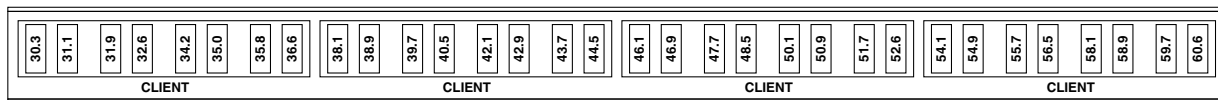
Figure 3-17 Top View of the Patch-Panel Bar

134824

- Step 6** As necessary, repeat Steps 3 through 5 for the remaining three Add RX ports on the 32WSS or MUX-O card, until all 32 LC connectors on the bottom row of the rear of the patch panel are connected.
- Step 7** At the adjacent 32DMX or DMX-O card in the same side of the shelf, plug the MPO connector of an MPO cable into the top Drop TX (30.3–36.6) port of the 32DMX or DMX-O card. If you are connecting a subsequent MPO cable, plug the MPO connector into the first vacant Drop TX card port below the last MPO cable that was installed.
- Step 8** Route the MPO cable slack through the patch-panel tray as necessary.

**Caution**

When you close the patch-panel tray, the cables must not be pinched, and the cable bend radius must be equal to or greater than the minimum radius that is recommended in your site specifications. As you route each cable through the patch-panel tray, make sure that adequate cable slack remains.

- Step 9** While facing the front of the patch panel, at the rear of the patch panel, plug the eight LC-connector fan-out cables on the MPO cable into their corresponding connectors on the top row of the patch panel. You should plug the fan-out cables from left to right (as you face the patch panel), following the numbers tagged (1 through 8) on the cables.
- Step 10** As necessary, repeat Steps 7 through 9 for the remaining three Drop TX ports on the 32DMX or DMX-O card, until all 32 LC connectors on the top row of the rear of the patch panel are connected.
- Step 11** For a hub or ROADM node, repeat Steps 2 through 10 to cable the other side of the shelf to the second patch panel. For a terminal node, go to Step 12.
- Step 12** Return to your originating procedure (NTP).

DLP-G316 Install Fiber-Optic Cables from TXP/MXP Cards to the Standard Patch-Panel Tray

Purpose	This task describes how to route fiber-optic cables from the patch panel to TXP and MXP cards.
Tools/Equipment	TXP or MXP card(s) Fiber-optic cable(s)
Prerequisite Procedures	NTP-G34 Install Fiber-Optic Cables on DWDM Cards and DCUs, page 3-56
Required/As Needed	As needed
Onsite/Remote	Onsite
Security Level	None

Step 1 At the appropriate TXP or MXP card, plug one end of a fiber-optic cable into the TX port of the DWDM adapter.

Step 2 As needed, route slack fiber-optic cable around the round cable retainers in the fiber-storage tray.



Caution

When you close the fiber-storage tray, the cables must not be pinched, and the cable bend radius must be equal to or greater than the minimum radius that is recommended in your site specifications. As you route each cable through the fiber-storage tray, make sure that adequate cable slack remains.

Step 3 On the DWDM (front) side of the patch panel, plug the other end of the cable into the connector on the bottom row that corresponds to the wavelength to which the TXP or MXP port is tuned. (See [Figure 3-17 on page 3-67](#) for a view of the wavelengths assigned to the patch-panel connectors).

[Figure 3-18](#) shows the patch-panel connectors from the front of the patch-panel tray.

Figure 3-18 Front View of the Patch Panel

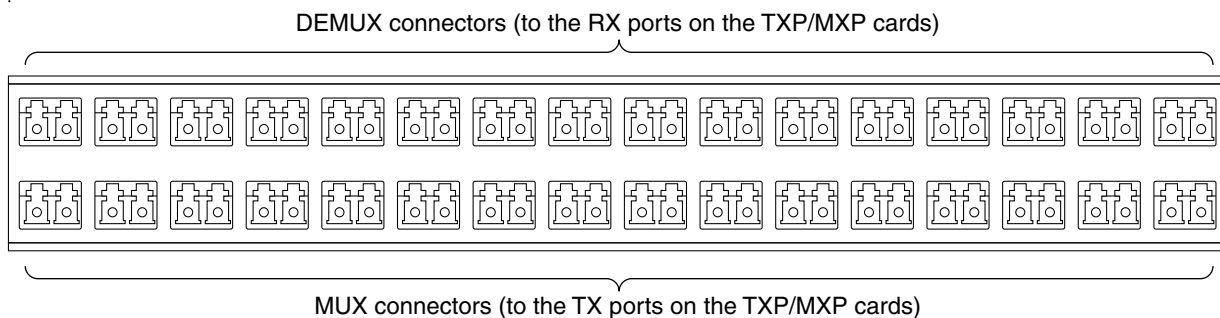

Step 4 Plug one end of a fiber-optic cable into the RX port of the DWDM adapter on that TXP/MXP card.

Step 5 On the DWDM (front) side of the patch panel, plug the other end of the cable into the connector on the top row that corresponds to the wavelength to which the TXP/MXP port is tuned.

Step 6 Repeat Steps 1 through 5 for all of the TXP/MXP cards that you want to connect to this patch panel.

Step 7 Return to your originating procedure (NTP).

DLP-G356 Install Fiber-Optic Cables from the 32WSS/32DMX and 32MUX-O/32DMX-O Cards to the Deep Patch-Panel Tray

Purpose	This task describes how to route fiber-optic cables from 32MUX-O, 32WSS, 32DMX-O, and 3DMX cards in a terminal, hub, or ROADM node to the deep patch-panel tray.
Tools/Equipment	<p>The following node types require the following equipment. The cards and patch panels should already be installed before you begin this procedure.</p> <p>Terminal node:</p> <ul style="list-style-type: none"> • One 32DMX-O card • One 32MUX-O card • One deep patch-panel tray, preinstalled with MPO cables (each MPO cable is terminated on one end with one multifiber push-on [MPO] connector and on the other end with eight LC-type connectors) <p>Hub node:</p> <ul style="list-style-type: none"> • Two 32DMX-O cards • Two 32MUX-O cards • Two deep patch-panel trays, preinstalled with MPO cables (each MPO cable is terminated on one end with one MPO connector and on the other end with eight LC-type connectors) <p>ROADM node:</p> <ul style="list-style-type: none"> • Two 32WSS cards • Two 32DMX cards • Two deep patch-panel trays, preinstalled with MPO cables (each MPO cable is terminated on one end with one multifiber push-on MPO connector and on the other end with eight LC-type connectors)
Prerequisite Procedures	NTP-G34 Install Fiber-Optic Cables on DWDM Cards and DCUs, page 3-56
Required/As Needed	As needed
Onsite/Remote	Onsite
Security Level	None



Note

For a ROADM or hub node, two patch panels will be used, one for the east side and one for the west. The east side 32WSS/32DMX card will connect to the east patch panel. The west side 32WSS/32DMX card will connect to the west patch panel. The MPO cables in the patch panel are preinstalled and routed out of the right side of the patch-panel tray.

-
- Step 1** Choose either the east or west side of the shelf to cable the 32MUX-O and 32DMX-O cards (or the 32WSS and 32DMX cards for an ROADM node).
- Step 2** On the patch panel, locate the MPO connectors ([Figure 3-15 on page 3-66](#)).
- Step 3** Route the preinstalled MPO cables out of the tray to the right or left ([Figure 3-19](#)).

Figure 3-19 Deep Patch-Panel Tray

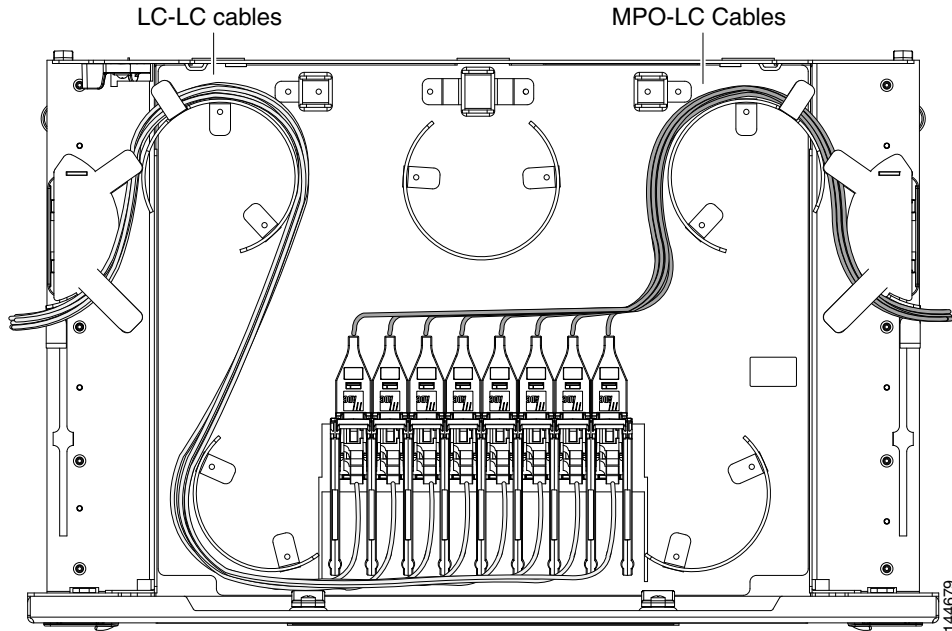

- Step 4** At the 32WSS or 32MUX-O card in the node, plug the MPO connector labeled “1 RX” on an MPO cable (Figure 3-15 on page 3-66) into the top Add RX (30.3–36.6) port of the card.
- Step 5** Plug the MPO connector labeled “2-RX” into the Add RX (38.1 - 44.5) port on the card.
- Step 6** Plug the MPO connector labeled “3-RX” into the Add RX (46.1 - 52.5) port on the card.
- Step 7** Plug the MPO connector labeled “4-RX” into the Add RX (54.1 - 60.6) port on the card.

**Caution**

When you close the patch-panel tray, the cables must not be pinched, and the cable bend radius must be equal to or greater than the minimum radius that is recommended in your site specifications. As you route each cable through the patch-panel tray, make sure that adequate cable slack remains.

Figure 3-20 shows the patch-panel ports and corresponding wavelengths.

Figure 3-20 Deep Patch-Panel Port Wavelengths

1	1532.6nm	1531.1nm	1530.3nm	1534.2nm	1538.1nm	1542.1nm	1546.1nm	1550.1nm	1554.1nm	1558.1nm	FX	TX
	FX										TX	
2	1536.6nm	1535.0nm	1534.2nm	1538.9nm	1542.9nm	1546.9nm	1550.9nm	1554.9nm	1558.9nm	FX	TX	
	FX									TX		
3	1540.5nm	1539.7nm	1538.9nm	1543.7nm	1547.7nm	1551.7nm	1555.7nm	1559.7nm	FX	TX		
	FX								TX			
4	1544.5nm	1543.7nm	1542.9nm	1547.7nm	1551.7nm	1555.7nm	1559.7nm	FX	TX			
	FX							TX				
5	1548.5nm	1547.7nm	1546.9nm	1551.7nm	1555.7nm	1559.7nm	FX	TX				
	FX						TX					
6	1552.5nm	1551.7nm	1550.9nm	1554.9nm	1558.9nm	FX	TX					
	FX					TX						
7	1556.5nm	1555.7nm	1554.9nm	1558.9nm	FX	TX						
	FX				TX							
8	1560.6nm	1559.7nm	1558.9nm	1562.9nm	1566.9nm	1570.9nm	FX	TX				
	FX						TX					

144676

- Step 8** At the adjacent 32DMX or DMX-O card in the same side of the shelf, plug the MPO connector labeled “1 TX” on the MPO cable (Figure 3-15 on page 3-66) into the top Drop TX (30.3–36.6) port of the card (Figure 3-20).
- Step 9** Plug the MPO connector labeled “2-TX” into the Drop TX (38.1 - 44.5) port on the card.
- Step 10** Plug the MPO connector labeled “3-TX” into the Drop TX (46.1 - 52.5) port on the card.
- Step 11** Plug the MPO connector labeled “4-TX” into the Drop TX (54.1 - 60.6) port on the card.

**Caution**

When you close the patch-panel tray, the cables must not be pinched, and the cable bend radius must be equal to or greater than the minimum radius that is recommended in your site specifications. As you route each cable through the patch-panel tray, make sure that adequate cable slack remains.

- Step 12** For a hub or ROADM node, repeat Steps 4 through 11 to cable the other side of the shelf to the second patch panel. For a terminal node, go to Step 13.
- Step 13** Return to your originating procedure (NTP).

DLP-G357 Install Fiber-Optic Cables from the TXP/MXP Cards to the Deep Patch-Panel Tray

Purpose	This task describes how to route fiber-optic cables from the deep patch panel to TXP and MXP cards.
Tools/Equipment	TXP or MXP card(s) Fiber-optic cable(s) MetroPlanner Internal Connections Report
Prerequisite Procedures	NTP-G34 Install Fiber-Optic Cables on DWDM Cards and DCUs, page 3-56
Required/As Needed	As needed
Onsite/Remote	Onsite
Security Level	None

Step 1 Refer to the MetroPlanner Internal Connections Report to connect the TXP/MXP card to the proper (east or west) patch panel. MetroPlanner denotes the west side as Slots 1 to 6 and the east side as Slots 12 to 17. At the appropriate TXP or MXP card, plug one end of a fiber-optic cable into the TX port of the DWDM adapter.

Step 2 As needed, route slack fiber-optic cable around the round cable retainers in the fiber-storage tray.



Caution

When you close the fiber-storage tray, the cables must not be pinched, and the cable bend radius must be equal to or greater than the minimum radius that is recommended in your site specifications. As you route each cable through the fiber-storage tray, make sure that adequate cable slack remains.

Step 3 Plug the other end of the cable into the RX connector on the patch panel that corresponds to the wavelength to which the TXP or MXP port is tuned. (See [Figure 3-20 on page 3-71](#) for a view of the wavelengths assigned to the patch-panel connectors).

Step 4 Plug one end of a fiber-optic cable into the RX port of the DWDM adapter on that TXP/MXP card.

Step 5 Plug the other end of the cable into the TX connector on the patch panel that corresponds to the wavelength to which the TXP/MXP port is tuned.

Step 6 Repeat Steps 1 through 5 for all of the TXP/MXP cards that you want to connect to this patch panel.

Step 7 Return to your originating procedure (NTP).

NTP-G191 Install Fiber-Optic Cables on Passthrough ROADM Nodes

Purpose	This procedure routes fiber-optic cables from a 32WSS card in a ROADM node in one shelf to the corresponding 32WSS card in a ROADM node in another shelf. The purpose of this routing is to connect East and West intershelf ROADMs in a passthrough configuration.
Tools/Equipment	Each ROADM node requires the listed equipment. The cards and fiber-storage trays should already be installed before you begin this procedure. <ul style="list-style-type: none"> • One 32WSS card • One fiber-storage tray • Two 3-meter fiber-optic cables, each terminated with a single LC connector on each end. • Cisco MetroPlanner Internal Connections Report
Prerequisite Procedures	DLP-G29 Install the Fiber-Storage Tray, page 1-66 DLP-G348 Use the Cisco MetroPlanner Shelf Layout Report, page 3-47
Required/As Needed	As needed
Onsite/Remote	Onsite
Security Level	None

-
- Step 1** Choose either the East or West side of the first shelf to cable the 32WSS card for the first ROADM node.
- Step 2** Choose the corresponding West or East side of the second shelf to cable the 32WSS card for the second ROADM node.
- Step 3** On the front of the fiber-storage tray that will be used for routing the fiber-optic cable, push the tabs on the left and right sides inward to release the lock on the tray.
- Step 4** Pull the fiber-storage tray away from the shelf until it is fully opened.
- Step 5** Open the fold-down door located at the bottom of both shelf assemblies to expose the cable-routing channels for each ([Figure 3-21](#)).

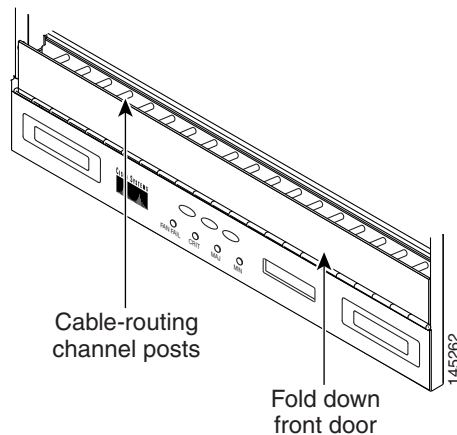
Figure 3-21 Managing Cables on the Front Panel

- Step 6** Plug one end of the first 3-meter fiber-optic cable into the EXP-TX connector on the first 32WSS card.
- Step 7** Route the fiber-optic cable through the shelf cable-routing channel and cutout on the appropriate side of the shelf assembly, as necessary.
- Step 8** Route the fiber-optic cable through the vertical fiber guide as needed to reach the entry to the fiber-storage tray.
- Step 9** Thread the cable into the fiber-storage tray at the appropriate side and around the first bend radius delimiter as shown (Figure 3-22).
- Step 10** As needed, route slack fiber-optic cable around the slack management cable retainers in the fiber-storage tray (Figure 3-22).

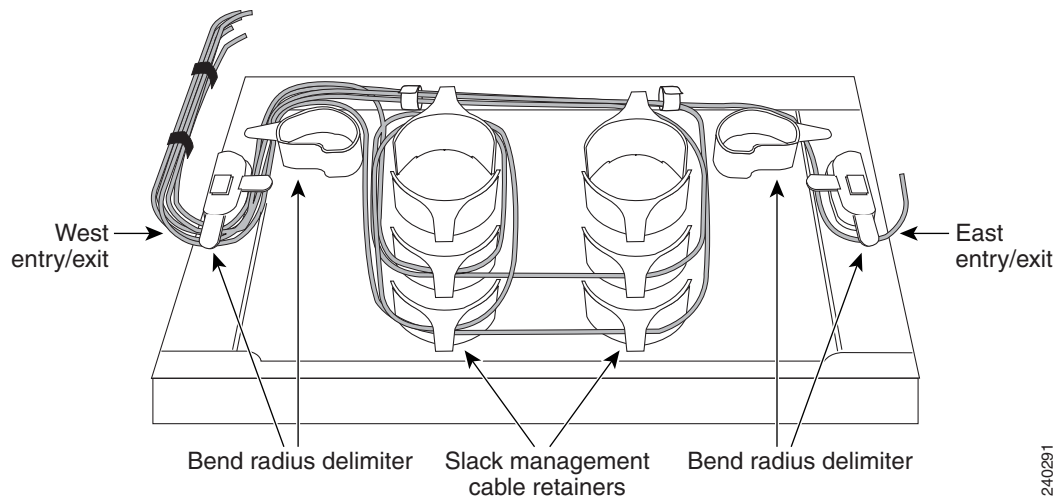
Figure 3-22 Fiber-Storage Tray**Caution**

When you close the fiber-storage tray, the cables must not be pinched, and the cable bend radius must be equal to or greater than the minimum radius that is recommended in your site specifications. As you route each cable through the fiber-storage tray, make sure that adequate cable slack remains.

- Step 11** Thread the fiber cable through the second bend delimiter and out the appropriate side of the fiber-storage tray as necessary.
- Step 12** Route the fiber-optic cable through the vertical fiber guide as needed to reach the second ROADM shelf where the second 32WSS is located.
- Step 13** Route the fiber-optic cable through the shelf cutout and through the shelf cable routing channel as needed.
- Step 14** Plug the end of the 3-meter fiber-optic cable into the EXP-RX port of the second 32WSS card.
- Step 15** Plug one end of the second 3-meter fiber-optic cable into the EXP-TX connector on the second 32WSS card.
- Step 16** Follow [Step 7](#) through [Step 14](#) to connect the EXP-TX connector of the second 32WSS card to the EXP-RX port of the first 32WSS card.
- Step 17** Close the fold-down doors located at the bottom of both shelf assemblies and slide the fiber-storage tray back into its normal locked position.
- Stop.** You have completed this procedure.
-

NTP-G141 Install Fiber-Optic Cables for Y-Cable Protection Modules

Purpose	This procedure installs and routes fiber-optic cables from the client signal to the Y-cable protection module (single mode or multimode), and from the Y-cable module to the transponder node. Using one Y-cable protection module, you can protect one client signal with two TXP or MXP cards, and two client signals with four TXP or MXP cards. You can use Y-cable protection modules that you have installed in a FlexLayer shelf, or Y-cable modules installed in a Y-cable module tray.
Tools/Equipment	Fiber-optic cables MetroPlanner Internal Connections Report
Prerequisite Procedures	DLP-G32 Install the Y-Cable Protection Modules in the FlexLayer Shelf, page 1-70 NTP-G32 Install the Transponder and Muxponder Cards, page 3-50
Required/As Needed	As needed
Onsite/Remote	Onsite
Security Level	None



Note Refer to the “Shelf Assembly Hardware” chapter in the *Cisco ONS 15454 DWDM Reference Manual* for more information about Y-cable protection.

- Step 1** As needed, complete the “[DLP-G375 Install Fiber-Optic Cables on the Y-Cable Modules in the FlexLayer Shelf](#)” task on page 3-76.
- Step 2** As needed, complete the “[DLP-G376 Install Fiber-Optic Cables on the Y-Cable Modules in the Y-Cable Module Tray](#)” task on page 3-77.

Stop. You have completed this procedure.

DLP-G375 Install Fiber-Optic Cables on the Y-Cable Modules in the FlexLayer Shelf

Purpose	This task installs fiber-optic cables from the TXP/MXP cards to the Y-cable modules installed in the FlexLayer shelves, and from the Y-cable modules to the client devices.
Tools/Equipment	Fiber-optic cables Cisco MetroPlanner Internal Connections Report
Prerequisite Procedures	DLP-G32 Install the Y-Cable Protection Modules in the FlexLayer Shelf, page 1-70 NTP-G32 Install the Transponder and Muxponder Cards, page 3-50
Required/As Needed	As needed
Onsite/Remote	Onsite
Security Level	None

Step 1 Referring to the Cisco MetroPlanner Internal Connections Report, install a fiber-optic cable between a TXP or MXP card and a Y-cable module.

If you want to protect one client signal, connect the fiber-optic cables according to either [Table 3-3](#) or [Table 3-4](#). To protect two client signals using a single Y-cable module, connect the cables according to both [Table 3-3](#) and [Table 3-4](#).

Table 3-3 Cable Connections for Y-Cable Protection of One Client Signal

From	To (Y-Cable Port Number)
Client 1 TX port	10
Client 1 RX port	5
TXP/MXP 1 TX port	1
TXP/MXP 1 RX port	2
TXP/MXP 2TX port	6
TXP/MXP 2RX port	7

Table 3-4 Cable Connections for Y-Cable Protection of a Second Client Signal

From	To (Y-Cable Port Number)
Client 2 TX port	12
Client 2 RX port	11
TXP/MXP 3 TX port	3
TXP/MXP 3 RX port	4

Table 3-4 Cable Connections for Y-Cable Protection of a Second Client Signal (continued)

From	To (Y-Cable Port Number)
TXP/MXP 4 TX port	8
TXP/MXP 4 RX port	9

Step 2 As needed, route slack fiber-optic cable around the round cable retainers in the fiber-storage tray as you install cables between the Y-cable module and the TXP or MXP cards ([Figure 3-11 on page 3-57](#)).

**Caution**

When you close the fiber-storage tray, the cables must not be pinched, and the cable bend radius must be equal to or greater than the minimum radius that is recommended in your site specifications. As you route each cable through the fiber-storage tray, make sure that adequate cable slack remains.

Step 3 Install a fiber-optic cable between the client device and the Y-cable module where you just installed a fiber-optic cable to the TXP/MXP card.

Step 4 Repeat Steps 1 through 3 for each Y-cable module you need to use for Y-cable protection.

Step 5 Return to your originating procedure (NTP).

DLP-G376 Install Fiber-Optic Cables on the Y-Cable Modules in the Y-Cable Module Tray

Purpose	This task installs fiber-optic cables from the TXP/MXP cards to the Y-cable modules installed in the Y-cable module tray, and from the Y-cable modules to the client devices.
Tools/Equipment	Fiber-optic cables (4-meter [13.12-foot]), single-mode or multimode as appropriate Cisco MetroPlanner Internal Connections Report
Prerequisite Procedures	DLP-G32 Install the Y-Cable Protection Modules in the FlexLayer Shelf, page 1-70 NTP-G32 Install the Transponder and Muxponder Cards, page 3-50
Required/As Needed	As needed
Onsite/Remote	Onsite
Security Level	None

Step 1 Open the drawer of the tray by pushing inward on the latches located at the left and right front of the tray.

Step 2 On each Y-cable module you will connect, use the tab to slide the module up so that it is fully extended and easily accessible in the tray.

Step 3 Referring to the Cisco MetroPlanner Internal Connections Report, install a 4-meter (13.12-foot) fiber-optic cable (single-mode or multimode, as appropriate) between a TXP or MXP card and the Y-cable module installed farthest to the left. Proceed according to the port label affixed to the front of the tray to identify the ports on each installed module ([Figure 3-23](#)).

Figure 3-23 Y-Cable Protection Port Label

Client TX	Client TX	Client TX	Client TX	Client TX	Client TX	Client TX	Client TX
Client RX	Client RX	Client RX	Client RX	Client RX	Client RX	Client RX	Client RX
TXP W TX	TXP W TX	TXP W TX	TXP W TX	TXP W TX	TXP W TX	TXP W TX	TXP W TX
TXP W RX	TXP W RX	TXP W RX	TXP W RX	TXP W RX	TXP W RX	TXP W RX	TXP W RX
TXP P TX	TXP P TX	TXP P TX	TXP P TX	TXP P TX	TXP P TX	TXP P TX	TXP P TX
TXP P RX	TXP P RX	TXP P RX	TXP P RX	TXP P RX	TXP P RX	TXP P RX	TXP P RX
#1	#2	#3	#4	#5	#6	#7	#8

144677

**Note**

You can use the label shown in [Figure 3-23](#) to take notes as to which wavelength/port you are connecting to each Y-cable module. “W” denotes the indicated Working port on the TXP or MXP card. “P” denotes the indicated Protect port on the TXP or MXP card.

**Note**

Protective covers are installed over the third and fourth ports on the Y-cable modules because they are not used.

As needed, route slack fiber-optic cable around the round cable retainers in the Y-cable module tray as you install cables between the Y-cable module and the TXP or MXP card ([Figure 3-24](#)).

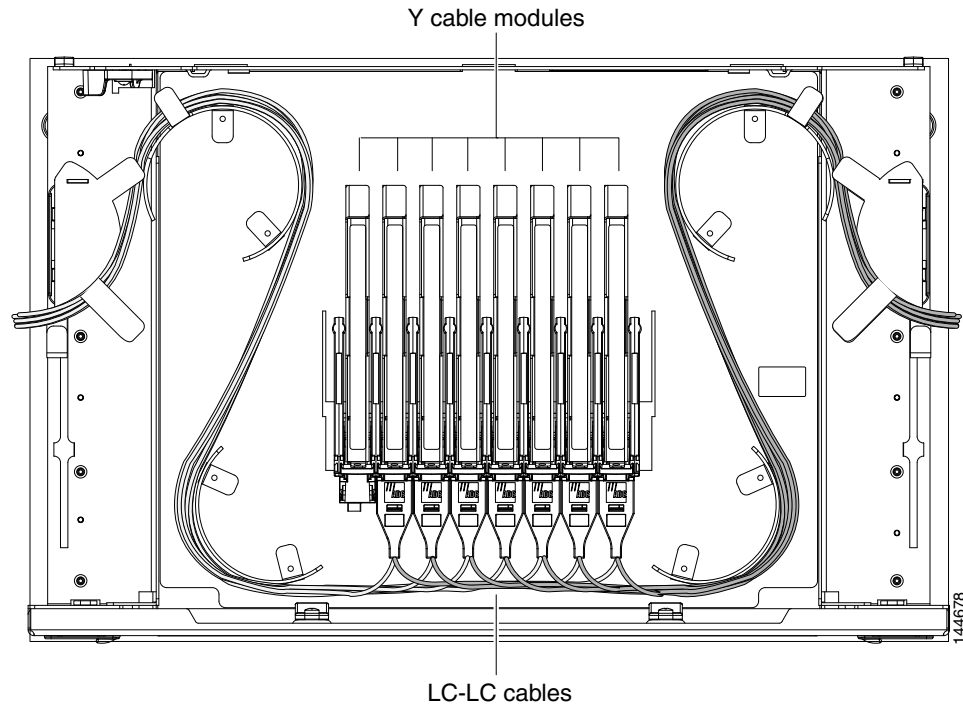
Figure 3-24 Y-Cable Protection Module Tray**Caution**

When you close the Y-cable module tray, the cables must not be pinched, and the cable bend radius must be equal to or greater than the minimum radius that is recommended in your site specifications. As you route each cable through the tray, make sure that adequate cable slack remains.

- Step 4** Referring to the Cisco MetroPlanner Internal Connections Report, install a fiber-optic cable of adequate length (single-mode or multimode, as appropriate) between the Y-cable module and the client signal that you want to protect.
- Step 5** As needed, route slack fiber-optic cable around the round cable retainers in the Y-cable module tray as you install cables between the Y-cable module and the TXP or MXP card.
- Step 6** Repeat Steps 2 through 5 for each Y-cable module you need to use for Y-cable protection.
- Step 7** To close the tray, unlock the drawer from the open position by depressing the red lock at the back left of the tray and push the tray closed.
- Step 8** Return to your originating procedure (NTP).

NTP-G152 Create and Verify Internal Patchcords

Purpose	This procedure creates the default internal patchcords, verifies the installed cards and calculates the connections that should be provisioned for them.
Tools/Equipment	Cisco MetroPlanner shelf layout Cisco MetroPlanner Internal Connections Report
Prerequisite Procedures	NTP-G22 Verify Common Card Installation, page 3-4 NTP-G139 Verify Cisco MetroPlanner Reports and Files, page 3-3
Required/As Needed	Required
Onsite/Remote	Onsite or remote
Security Level	Superuser

-
- Step 1** Complete the “[DLP-G46 Log into CTC](#)” task on page 2-25 at the node where you want to provision the DWDM cable connections. If you are already logged in, continue with [Step 2](#).
- Step 2** In node view (single-shelf mode) or multishelf view (multishelf mode), click the **Provisioning > WDM-ANS > Internal Patchcords** tabs.
- Step 3** Click **Default Patchcords**.

CTC verifies that the cards installed in the ONS 15454 shelf are compatible and will operate together as a valid DWDM node configuration. Furthermore, based on the cards installed or preprovisioned, CTC calculates the intra-shelf patchcords that are expected to be installed. If the cards are not compatible or are missing, for example, if an OPT-BST is installed but an OSCM card is not installed, the calculate connections function generates an error.



Note The Internal Connections tab does not show OPT-PRE DCU connections, span connections, or connections between the TXP/MXP cards and the DWDM cards.



Note The connections calculation is not based on the Cisco MetroPlanner shelf layout or Internal Connections Report. Calculations are based on the cards that are physically installed. If the Cisco MetroPlanner shelf layout calls for a hub node but OADM cards are installed, CTC calculates connections based on the cards expected for an OADM node.

- Step 4** If no errors were generated, continue with [Step 5](#). If errors appear, verify that the cards installed in the shelf match the Cisco MetroPlanner shelf layout. If the wrong cards are installed or are missing, install the correct cards following the “[NTP-G30 Install the DWDM Cards](#)” procedure on page 3-44.
- Step 5** Verify that the connections in the CTC Connections tab match the connections in the Cisco MetroPlanner Internal Connections Report for the DWDM cards (see the “[DLP-G349 Use the Cisco MetroPlanner Internal Connections Report](#)” task on page 3-58). The CTC Connections tab will not show OPT-PRE DCUs, connections, span connections, or connections between TXP and MXP cards and the DWDM cards.
- Step 6** Complete the “[DLP-G354 Create an Internal Patchcord Manually](#)” task on page 3-81 for any connections that require manual provisioning. Connections that require manual creation appear under Manually Set: Yes in the Cisco MetroPlanner Internal Connections Report. If you need to delete a connection, complete the “[DLP-G355 Delete an Internal Patchcord](#)” task on page 3-82.



Note Although CTC calculates most DWDM connections automatically, some connections cannot be calculated because of the DWDM card type and position. You must create these connections manually. For example, connections related to optical bypass circuits must be manually provisioned.

Stop. You have completed this procedure.

DLP-G354 Create an Internal Patchcord Manually

Purpose	This task creates an internal patchcord manually when CTC is unable to calculate the internal patchcords automatically.
Tools/Equipment	None
Prerequisite Procedures	DLP-G46 Log into CTC, page 2-25
Required/As Needed	As needed
Onsite/Remote	Onsite or remote
Security Level	Superuser



Note Use only one management interface to complete the creation of internal patchcords. For example, do not begin the internal patchcord creation using the TL1 interface or CTP XML file and end the internal patchcord creation using CTC.

- Step 1** In node view (single-shelf mode) or multishelf view (multishelf mode), click the **Provisioning > WDM-ANS > Internal Patchcord** tabs.
- Step 2** Click **Create**.
- Step 3** In the Create Optical Link dialog box, choose the From and To slots and ports from the drop-down lists.
- Step 4** If the connection is unidirectional, uncheck the **bidirectional** check box.
- Step 5** Click **OK**. The new connection appears in the Connections Report, but its State is Uncommitted.
- Step 6** Click the new connection in the table. Click **Commit**. The connection state changes to Connected.
- Step 7** If you need to create additional connections, repeat Steps 2 through 6 for each new connection. If not, continue with [Step 8](#).
- Step 8** Return to your originating procedure (NTP).



Note To successfully create an Internal Patchcord between WSS/DMX channel port and TxP trunk port, the TxP must be chosen as "From" end point while WSS/DMX must be chosen as "To" end point.

DLP-G355 Delete an Internal Patchcord

Purpose	This task deletes an internal patchcord.
Tools/Equipment	None
Prerequisite Procedures	DLP-G46 Log into CTC, page 2-25
Required/As Needed	As needed
Onsite/Remote	Onsite or remote
Security Level	Superuser

-
- Step 1** In node view (single-shelf mode) or multishelf view (multishelf mode), click the **Provisioning > WDM-ANS > Internal Patchcord** tabs.
- Step 2** Click the connection you want to delete.
- Step 3** Click **Delete**, then click **Yes**.
- Step 4** Return to your originating procedure (NTP).
-

NTP-G37 Run Automatic Node Setup

Purpose	This procedure runs the CTC DWDM automatic node setup (ANS) function. ANS adjusts the values of the variable optical attenuators (VOAs) to equalize the per-channel power at the amplifier level.
Tools/Equipment	The Cisco MetroPlanner Installation Parameters file
Prerequisite Procedures	NTP-G152 Create and Verify Internal Patchcords, page 3-80 NTP-G143 Import the Cisco MetroPlanner NE Update Configuration File, page 3-38 NTP-G139 Verify Cisco MetroPlanner Reports and Files, page 3-3
Required/As Needed	Required
Onsite/Remote	Onsite or remote
Security Level	Superuser

-
- Step 1** Complete the “[DLP-G46 Log into CTC](#)” task on [page 2-25](#) at the node where you want to run ANS. If you are already logged in, continue with [Step 2](#).
- Step 2** Referring to the Cisco MetroPlanner Installation Parameters (see [Table 3-1 on page 3-3](#)), identify the parameters that have a Yes in the Manually Set column. If there are no parameters that have a Yes in the Manually Set column, continue with [Step 6](#).
- Step 3** In CTC, display the card where the parameter is to be manually provisioned in card view.
- Step 4** Enter the specified Calibration parameter from the Cisco MetroPlanner Installation Parameters table. Click **Apply**.
- Step 5** Repeat [Steps 2](#) through [4](#) for all parameters in the Cisco MetroPlanner Installation Parameters table that display Yes in the Manually Set field.
- Step 6** Change to node view (single-shelf mode) or multishelf view (multishelf mode).

- Step 7** Click the **Provisioning > WDM-ANS > Port Status** tabs.
- Step 8** Click **Launch ANS**.
- Step 9** In the Apply Launch ANS dialog box, click **Yes**.
- Step 10** In the Launch ANS confirmation dialog box, click **OK**.
- Step 11** Verify that one of the following statuses appears in the Link Status column for all ports:
- Success - Changed—The parameter setpoint was recalculated successfully.
 - Success - Unchanged—The parameter setpoint did not need recalculation.
 - Not Applicable—The parameter setpoint does not apply to this node type.

If one of the following statuses is shown, complete the provided instructions:

- Fail - Out of Range—The calculated setpoint is outside the expected range. Repeat the “[NTP-G152 Create and Verify Internal Patchcords](#)” procedure on page 3-80 to verify that all connections were provisioned correctly, paying attention to connections that require manual provisioning.



Note The Fail - Out of Range condition must be cleared before proceeding. Contact your next level of support if you are unable to clear this status.

- Fail - Port in IS State—The parameter could not be calculated because the port is in service. This status should normally not appear at this point in node turn-up. If it does, display the card in card view, change the port administrative state to OOS,DSL B (ANSI) or Locked,disabled (ETSI), and repeat Steps 6 through 11.

Stop. You have completed this procedure.

NTP-G38 Provision OSC Terminations

Purpose	This procedure provisions the optical service channel (OSC) terminations. The OSC provides a bidirectional channel that connects all nodes within a DWDM ring. The OSC carries a supervisory data channel and synchronizes clocking at network nodes. The OSC also carries a user data channel.
Tools/Equipment	None
Prerequisite Procedures	NTP-G143 Import the Cisco MetroPlanner NE Update Configuration File, page 3-38
Required/As Needed	Required
Onsite/Remote	Onsite or remote
Security Level	Superuser

- Step 1** Complete the “[DLP-G46 Log into CTC](#)” task on page 2-25 at the node where you want to provision the OSC terminations. If you are already logged in, continue with [Step 2](#).
- Step 2** In node view (single-shelf mode) or multishelf view (multishelf mode), click the **Provisioning > Comm Channels > OSC** tabs.
- Step 3** In the OSC Terminations area, click **Create** ([Figure 3-25](#)).

Figure 3-25 OSC Terminations Area

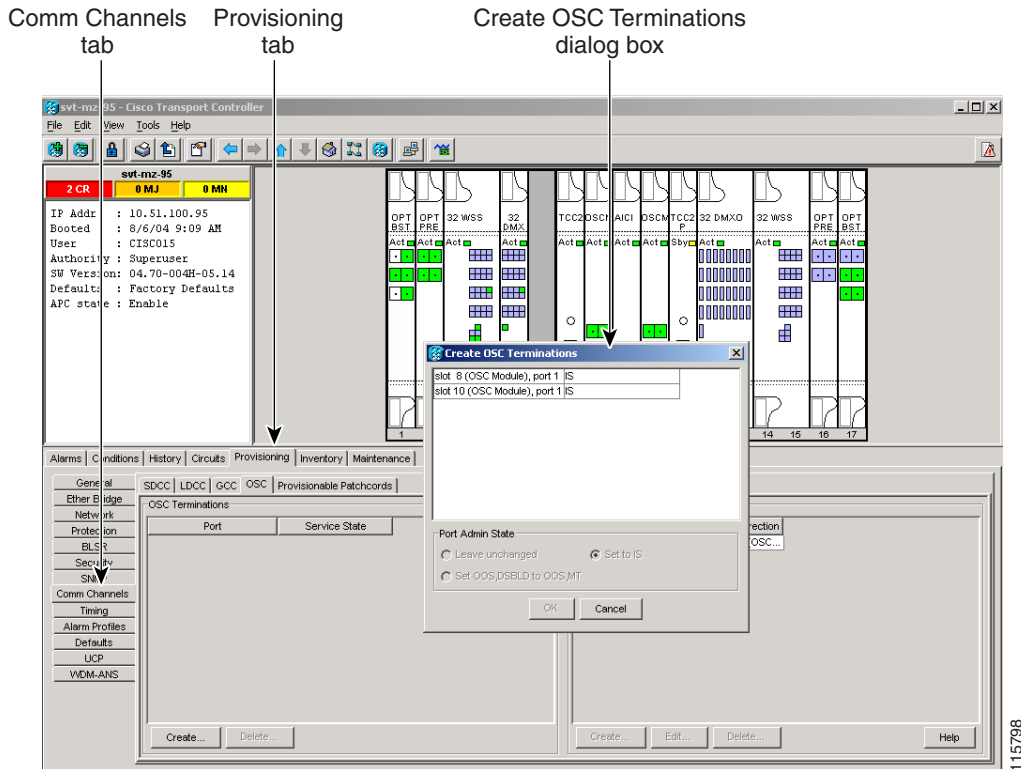

- Step 4** In the Create OSC Terminations dialog box, choose the ports where you want to create the OSC termination. To select more than one port, press the **Shift** key (to select a range of ports) or the **Ctrl** key (to select multiple individual ports).



Note The number of OSC terminations you create depends on the node type defined by Cisco MetroPlanner. Terminal nodes require one OSC termination. Hub, OADM, and ROADM nodes require two OSC termination.

- Step 5** In the Layer 3 area, check the OSI box if the OSC termination is between the ONS 15454 and another ONS node, and third party network elements (NEs) that use the OSI protocol stack are on the same network. If you checked OSI, complete the following steps. If not, continue with [Step 6](#).
- a. Click **Next**.
 - b. Provision the following fields:
 - Router—Choose the OSI router.
 - ESH—Set the ESH propagation frequency. End system NEs transmit ESHs to inform other ESs and ISs about the NSAPs they serve. The default is 10 seconds. The range is 10 to 1000 seconds.
 - ISH—Sets the ISH PDU propagation frequency. Intermediate system NEs send ISHs to other ESs and ISs to inform them about the IS NETs it serves. The default is 10 seconds. The range is 10 to 1000 seconds.
 - IIH—Sets the IIH PDU propagation frequency. The IS-IS Hello PDUs establish and maintain adjacencies between ISSs. The default is 3 seconds. The range is 1 to 600 seconds.

- Metric—Sets the cost for sending packets on the LAN subnet. The IS-IS protocol uses the cost to calculate the shortest routing path. The default metric cost for LAN subnets is 20. It normally should not be changed.

Step 6 Click **Finish**. Ports are automatically placed in service. The following alarms might appear in the node view (single-shelf mode) or multishelf view (multishelf mode) Alarms tab Description field. They will remain until all the network OSC connections between the adjacent nodes are created:

- SDCC Termination Failure on the OSCM or OSC-CSM card
- LOS on the OC-3 port (Port 1) on the OSCM, OSC-CSM, or OPT-BST card
- OPWR-LFAIL on the OPT-BST or OSC-CSM card



Note After the OSC termination is created, the line ports are placed in service and span power levels are checked.

Stop. You have completed this procedure.

NTP-G39 Verify OSCM Transmit Power

Purpose	This procedure verifies that the transmit power for the ONS 15454 OSCM and the OSC-CSM cards is correct.
Tools/Equipment	None
Prerequisite Procedures	NTP-G37 Run Automatic Node Setup, page 3-82
Required/As Needed	Required
Onsite/Remote	Onsite or remote
Security Level	Superuser

- Step 1** Complete the “[DLP-G46 Log into CTC](#)” task on page 2-25 at the node where you want to verify the OSCM or OSC-CSM transmit power. If you are already logged in, continue with [Step 2](#).
- Step 2** Disable ALS on the west or (for terminal nodes) the terminal side OSCM or OSC-CSM card:
- In the node view (single-shelf mode) or shelf view (multishelf mode), double-click the west or terminal-side OSCM or OSC-CSM card.
 - Click the **Maintenance > ALS** tabs.
 - From the ALS Mode drop-down list, choose **Disable**.
 - Click **Apply**. Click **Yes** on the confirmation dialog box.
- Step 3** If an OSC-CSM or OSCM card is installed on the east side, complete the following steps. If not, continue with [Step 4](#).
- In the node view (single-shelf mode) or shelf view (multishelf mode), double-click the east OSCM or OSC-CSM card.
 - Click the **Maintenance > ALS** tabs.
 - From the ALS Mode drop-down list, choose **Disable**.
 - Click **Apply**. Click **Yes** on the confirmation dialog box.

- Step 4** Complete the “[DLP-G314 Verify OSCM Transmit Power](#)” task on page 3-86.
- Step 5** Change ALS to Auto Restart on the west or (for terminal nodes) the terminal side OSCM or OSC-CSM card:
- In the node view (single-shelf mode) or shelf view (multishelf mode), double-click the west or terminal-side OSCM or OSC-CSM card.
 - Click the **Maintenance > ALS** tabs.
 - From the ALS Mode drop-down list, choose **Auto Restart**.
 - Click **Apply**. Click **Yes** on the confirmation dialog box.
- Step 6** If an OSC-CSM or OSCM card is installed on the east side, complete the following steps. If not, you have completed this procedure.
- In the node view (single-shelf mode) or shelf view (multishelf mode), double-click the east OSCM or OSC-CSM card.
 - Click the **Maintenance > ALS** tabs.
 - From the ALS Mode drop-down list, choose **Auto Restart**.
 - Click **Apply**. Click **Yes** on the confirmation dialog box.
- Stop. You have completed this procedure.**
-

DLP-G314 Verify OSCM Transmit Power

Purpose	This procedure verifies that the transmit power of the OSCM card is correct.
Tools/Equipment	None
Prerequisite Procedures	“ DLP-G46 Log into CTC ” task on page 2-25
Required/As Needed	Required
Onsite/Remote	Onsite or remote
Security Level	Superuser



Note Throughout this task, west refers to Slots 1 through 8, and east refers to Slots 10 through 17.

- Step 1** Display the OSCM card in card view.
- Step 2** Click the **Provisioning > Optical Line > Parameters** tabs.
- Step 3** Record the Port 3 (OSC TX) Power value: _____. If an OPT-PRE card is installed in the same side of the shelf as the OSCM, continue with [Step 4](#). If not, verify that the value is equal to -5 dBm ± 0.5 dBm. If so, continue with [Step 7](#). If not, continue with [Step 6](#), Substep a.
- Step 4** Change to node view (single-shelf mode) or multishelf view (multishelf mode), then click the **Provisioning > WDM-ANS** tabs.
- Step 5** Record the amplifier working mode value from one of the following:
- For OSCM cards installed on the east side:
- In the Selector window on the left, expand the East Side parameters tree view.

- b. Expand the RX category.
- c. Expand the Amplifier category, then highlight **Working Mode**.
- d. Record the EastSide.Rx.Amplifier.Working Mode parameter displayed in the right pane: _____

For OSCM cards installed on the west side:

- a. In the Selector window on the left, expand the West Side parameters tree view.
- b. Expand the RX category.
- c. Expand the Amplifier category, then highlight **Working Mode**.
- d. Record the WestSide.Rx.Amplifier.Working Mode parameter displayed in the right pane: _____

Step 6 If the working mode recorded in [Step 5](#) is Control Gain, verify that the value recorded in [Step 3](#) is equal to -5 dBm ± 0.5 dBm. If the value recorded in [Step 5](#) is Control Power, verify that the value recorded in [Step 3](#) is equal to 0.5 dBm, ± 0.5 dBm. If the power level is not within this range, complete the following steps. Otherwise, continue with [Step 7](#).

- a. Click the **Maintenance > ALS** tabs. Verify that the ALS Command is set to OSRI Off. If not, click the cell and choose **Off** from the drop-down list. Click **Apply**, then click **Yes**.
- b. Clean the optical connections. See the “[NTP-G115 Clean Fiber Connectors](#)” procedure on [page 13-25](#).
- c. Complete the following procedures:
 - Delete the two OSC channels using the “[DLP-G186 Delete an OSC Termination](#)” task on [page 10-44](#).
 - Complete the “[NTP-G37 Run Automatic Node Setup](#)” procedure on [page 3-82](#).
 - Create the OSC channels using the “[NTP-G38 Provision OSC Terminations](#)” procedure on [page 3-83](#).
- d. Repeat [Step 3](#) through [Step 6](#). If the power level is still not within the specified range, contact your next level of support.

Step 7 Return to your originating procedure (NTP).

NTP-G163 Upgrade Nodes in Single-Shelf Mode to Multishelf Mode

Purpose

This procedure upgrades nodes in single-shelf mode to multishelf mode.

Tools/Equipment

The node you plan to use as the node controller must be equipped with optical units and cannot have a cross-connect card installed. Any nodes that you plan to add to the multishelf configuration as subtending shelves can be equipped with transponder and muxponder units. For more information on multishelf configurations, see the “Node Reference” chapter in the *Cisco ONS 15454 DWDM Reference Manual*.

- Prerequisite Procedures**
- [NTP-G22 Verify Common Card Installation, page 3-4](#)
 - [NTP-G145 Connect a Multishelf Node and Subtending Shelves to an MS-ISC-100T Card, page 1-78](#) or
 - [NTP-G158 Connect a Multishelf Node and Subtending Shelves to a Cisco Catalyst 2950, page 1-80](#)
 - [DLP-G267 Disable Node Security Mode, page 10-22](#)
 - [DLP-G347 Delete Optical Channel Client Connections, page 7-8](#) if circuits exist on the transponder/muxponder shelf to be upgraded
 - [DLP-G187 Delete a Provisionable Patchcord, page 10-45](#) as needed on the transponder/muxponder shelf to be upgraded

**Caution**

Upgrading a single-shelf transponder/muxponder shelf to a subtending shelf in a multishelf node is traffic affecting if OCHCC circuits exist on external patchcords between the OCh filters of the node controller and TXP/MXP trunk ports of the shelf to be upgraded. Before beginning the upgrade procedure, you must delete the OCHCC circuits and the external patchcords. You will replace them with internal patchcords between the optical shelf (node controller) and the preprovisioned TXP/MXP subtending shelf when performing the upgrade procedure.

Required/As Needed	As needed
Onsite/Remote	Onsite
Security Level	Superuser

**Caution**

An optical shelf in a multishelf configuration must be provisioned as the node controller shelf and not a subtending shelf, otherwise traffic will be dropped. If no slots are available on an optical shelf to install the MS-ISC-100T cards needed for a node controller shelf, install and configure the Cisco Catalyst 2950. See the “[NTP-G158 Connect a Multishelf Node and Subtending Shelves to a Cisco Catalyst 2950](#)” section on page 1-80.

**Note**

Before you begin this procedure to upgrade a Software Release 7.0 single-shelf node to a multishelf node, you must disable the security mode.

- Step 1** Complete the “[DLP-G46 Log into CTC](#)” task on page 2-25 at the node that you want to configure as a multishelf node.
- Step 2** If you want to configure a shelf as the node controller, continue with [Step 3](#). If you want to configure a shelf as a subtending shelf, continue with [Step 4](#).
- Step 3** To set up the login node as the node controller, complete the following steps:
- a. In node view (single-node mode) or multishelf view (multishelf mode), click the **Provisioning > General > Multishelf Config** tabs.
 - b. Click **Enable as Node Controller**.
 - c. From the LAN Config drop-down list, complete one of the following:

- Choose **Ethernet Switch** if MS-ISC-100T cards or the Catalyst 2950 switches are already installed and configured.
 - Choose **Stand-Alone** if MS-ISC-100T cards are not installed yet but will be in the final layout or if this is a line amplifier or an OSC-only site. This option will allow a safe migration of the TCC2/TCC2P database when the multishelf configuration is complete.
- d. Click **Apply**.
 - e. In the confirmation dialog box, click **Yes** to allow the node to reboot. The CTC view changes to network view and the node icon changes to gray. Wait for the reboot to finish. (This might take several minutes.)
 - f. After the node reboots, double-click the node. The multishelf view appears.



Note The shelf ID of the node controller is automatically assigned as 1.

- Step 4** To add a node equipped with transponder and muxponder cards as a subtending shelf in the multishelf configuration, complete the following:
- a. In multishelf view, right-click in the white space in the rack and choose **Add Shelf**.
 - b. In the Shelf ID Selection dialog box, choose a shelf ID (from 2 to 8) from the drop-down list.
 - c. Click **OK**. The shelf appears in the multishelf view.
 - d. Preprovision the new shelf so that it has the same provisioning as the actual shelf that you will add as the subtending shelf:



Caution

If the subtending shelf is not preprovisioned, traffic will be lost.

- Cards, PPMs, administrative states, client and trunk port configuration—For more information on card and port settings, see [Chapter 5, “Provision Transponder and Muxponder Cards.”](#)
 - Timing—For more information, see the [“NTP-G53 Set Up Timing” procedure on page 6-4.](#)
 - GCC—For more information, see the [“DLP-G76 Provision DCC/GCC Terminations” task on page 7-22.](#)
 - Internal patchcords—Replace the deleted external patchcords with internal patchcords between the optical shelf (node controller) and the preprovisioned TXP/MXP subtending shelf. For more information, see the [“NTP-G152 Create and Verify Internal Patchcords” procedure on page 3-80.](#)
- e. Disconnect the cross-over (CAT-5) LAN cable from the RJ-45 (LAN) port of the subtending shelf TCC2/TCC2P card in Slot 11.
 - f. Connect your Windows PC or Solaris workstation NIC to the RJ-45 (LAN) port on the TCC2/TCC2P card in Slot 11.
 - g. Complete the [“DLP-G46 Log into CTC” task on page 2-25](#) at the subtending shelf.
 - h. Click the **Provisioning > General > Multishelf Config** tabs.
 - i. Click **Enable as Subtended Shelf**.
 - j. From the Shelf ID drop-down list, choose the shelf ID that you created in Step **b**.
 - k. Click **Apply**.
 - l. In the confirmation dialog box, click **Yes** to reboot the shelf. The CTC view changes to network view and the node icon changes to gray. Wait for the reboot to finish. (This might take several minutes.)

- m. Disconnect your Windows PC or Solaris workstation NIC from the RJ-45 (LAN) port of the subtending shelf TTC2/TCC2P card in Slot 11.
- n. Reconnect the cross-over (CAT-5) LAN cable (disconnected in Step e) to the RJ-45 (LAN) port of the subtending shelf TCC2/TCC2P card in Slot 11.
- o. Repeat Steps a through n to set up additional subtending shelves.



Note CTM users can use the CTM NE Explorer to monitor and configure single-shelf and multishelf nodes. When the upgrade is complete, the original individual subtending shelves will remain the CTM network view and must be manually deleted. For detailed information, refer to the *Cisco Transport Manager User Guide*, Appendix B, “NE Explorer Information.”

Stop. You have completed this procedure.



Perform Node Acceptance Tests

This chapter provides test procedures to verify that the cards installed in the ONS 15454 are performing correctly. The procedures are optional.



Note

Unless otherwise specified, “ONS 15454” refers to both ANSI (SONET) and ETSI (SDH) shelf assemblies.



Note

This chapter does not test the TXP or MXP card installation. TXP and MXP card installation and verification is performed in [Chapter 5, “Provision Transponder and Muxponder Cards.”](#)

Before You Begin

This section lists the non-trouble procedures (NTPs) that you need to complete to validate a dense wavelength division multiplexing (DWDM) node. Turn to a procedure for applicable detailed level procedures (DLPs).

1. [NTP-G41 Perform the Terminal or Hub Node with 32MUX-O and 32DMX-O Cards Acceptance Test, page 4-2](#)—Complete this procedure to test terminal and hub nodes with 32MUX-O and 32DMX-O cards installed.
2. [NTP-G42 Perform the Terminal Node with 32WSS and 32DMX Cards Acceptance Test, page 4-8](#)—Complete this procedure to test terminal nodes with 32WSS and 32DMX cards installed.
3. [NTP-G153 Perform the Terminal Node with 32WSS-L and 32DMX-L Cards Acceptance Test, page 4-13](#)—Complete this procedure to test terminal nodes with 32WSS-L and 32DMX-L cards installed.
4. [NTP-G43 Perform the ROADM Node with 32WSS and 32DMX Cards Acceptance Test, page 4-20](#)—Complete this procedure to test reconfigurable optical add/drop multiplexing (ROADM) nodes with 32WSS and 32DMX cards installed.
5. [NTP-G154 Perform the ROADM Node with 32WSS-L and 32DMX-L Cards Acceptance Test, page 4-42](#)—Complete this procedure to test reconfigurable optical add/drop multiplexing (ROADM) nodes with 32WSS-L and 32DMX-L cards installed.
6. [NTP-G44 Perform the Anti-ASE Hub Node Acceptance Test, page 4-64](#)—Complete this procedure to test anti-amplified spontaneous emission (anti-ASE) hub nodes.
7. [NTP-G45 Perform the C-Band Line Amplifier Node with OSCM Cards Acceptance Test, page 4-66](#)—Complete this procedure to test C-band line amplifier nodes with OSCM cards installed on both the east and west sides of the shelf.

8. [NTP-G155 Perform the L-Band Line Amplifier Node with OSCM Cards Acceptance Test, page 4-70](#)—Complete this procedure to test L-band line amplifier nodes with OSCM cards installed on both the east and west sides of the shelf.
9. [NTP-G46 Perform the C-Band Line Amplifier Node with OSC-CSM Cards Acceptance Test, page 4-74](#)—Complete this procedure to test C-band line amplifier nodes with OSC-CSM cards installed on both the east and west sides of the shelf.
10. [NTP-G156 Perform the L-Band Line Amplifier Node with OSC-CSM Cards Acceptance Test, page 4-78](#)—Complete this procedure to test L-band line amplifier nodes with OSC-CSM cards installed on both the east and west sides of the shelf.
11. [NTP-G47 Perform the C-Band Line Amplifier Node with OSCM and OSC-CSM Cards Acceptance Test, page 4-82](#)—Complete this procedure to test C-band line amplifier nodes with OSCM and OSC-CSM cards installed.
12. [NTP-G157 Perform the L-Band Line Amplifier Node with OSCM and OSC-CSM Cards Acceptance Test, page 4-86](#)—Complete this procedure to test L-band line amplifier nodes with OSCM and OSC-CSM cards installed.
13. [NTP-G48 Perform the OADM Node Acceptance Test on a Symmetric Node with OSCM Cards, page 4-90](#)—Complete this procedure to test optical add/drop multiplexing (OADM) nodes with OSCM cards installed on both the east and west sides of the shelf.
14. [NTP-G49 Perform the OADM Active Node Acceptance Test on a Symmetric Node with OSC-CSM Cards, page 4-102](#)—Complete this procedure to test OADM nodes with OSC-CSM and OPT-BST or OPT-BST-E cards installed on both the east and west sides of the shelf.
15. [NTP-G50 Perform the OADM Passive Node Acceptance Test on a Symmetric Node with OSC-CSM Cards, page 4-108](#)—Complete this procedure to test OADM nodes with OSC-CSM cards installed on both the east and west sides of the shelf and no OPT-BST or OPT-BST-E cards.

NTP-G41 Perform the Terminal or Hub Node with 32MUX-O and 32DMX-O Cards Acceptance Test

Purpose	This procedure tests a DWDM terminal or hub node provisioned for C-band wavelengths with 32MUX-O and 32DMX-O cards installed.
Tools/Equipment	One of the following: <ul style="list-style-type: none"> • A tunable laser • TXP_MR_10E_C An optical power meter or optical spectrum analyzer 2 bulk attenuators (10 dB) with LC connectors
Prerequisite Procedures	Chapter 3, “Turn Up a Node”
Required/As Needed	Required
Onsite/Remote	Onsite
Security Level	Superuser



Note

This procedure tests the west side of hub nodes first, then the east side. If you are testing a terminal node, apply instructions for the west side of the hub node to the terminal side (east or west) of the terminal node.

**Note**

Optical power measurements require either a tunable laser or a multirate transponder to generate the proper optical wavelength. If multirate transponders were installed during completion of [Chapter 3, “Turn Up a Node,”](#) they can be used for this procedure. No additional cabling changes are needed.

- Step 1** Complete the [“DLP-G46 Log into CTC” task on page 2-25](#) at the hub or terminal node that you want to test. If you are already logged in, continue with [Step 2](#).
- Step 2** From the View menu, choose **Go to Network View**.
- Step 3** Click the **Alarms** tab.
- Verify that the alarm filter is not on. See the [“DLP-G128 Disable Alarm Filtering” task on page 8-28](#) as necessary.
 - Verify that no equipment alarms appear indicating equipment failure or other hardware problems. (Equipment alarms are indicated by an EQPT in the Alarms tab Cond column.) If equipment failure alarms appear, investigate and resolve them before continuing. Refer to the *Cisco ONS 15454 DWDM Troubleshooting Guide* for procedures.

**Note**

If optical service channel (OSC) terminations are created, there will be two alarms, one for low power on the OPT-BST or OPT-BST-E card, and the other an OSC channel alarm.

- Step 4** In node view (single-shelf mode) or multishelf view (multishelf mode), click the **Provisioning > WDM-ANS > Port Status** tabs. Verify that all statuses under Link Status are listed as Success - Changed, Success - Unchanged, or Not Applicable. If any are not, complete the [“NTP-G37 Run Automatic Node Setup” procedure on page 3-82](#).
- Step 5** Create a physical loopback on the west (or terminal) OPT-BST or OPT-BST-E amplifier by using a patchcord with 10-dB bulk attenuators to connect the LINE TX port to the LINE RX port.
- Step 6** Verify that the OSC link becomes active on the west OSCM or OSC-CSM card. (The OSC termination must already be provisioned. If not, complete the [“NTP-G38 Provision OSC Terminations” procedure on page 3-83](#).)
- Step 7** Set the tunable laser or the TXP_MR_10E_C card to the first wavelength of the 100-GHz ITU-T C-band grid (1530.33 nm). Refer to the tunable laser manufacturer’s documentation or the [“DLP-G268 Provision TXP_MR_10E_C Cards for Acceptance Testing” task on page 4-4](#).
- Step 8** Connect the tunable laser transmitter or TXP_MR_10E_C card DWDM TX port to the CHAN RX 01 port on the west (or terminal) 32MUX-O card using the available patch panel.
- Step 9** Display the west (or terminal) 32MUX-O card in card view.
- Step 10** Click the **Provisioning > Optical Chn > Parameters** tabs.
- Step 11** Change the Port 1 administrative state to **OOS,MT** (ANSI) or **Locked,maintenance** (ETSI).
- Step 12** Verify that the Port 1 power level reaches the provisioned VOA Power Ref setpoint.

**Note**

The tunable laser minimum output optical power (Pout) must be 6 dBm. If the output power is lower than the specified value, the 32MUX-O card might not reach the provisioned setpoint.

- Step 13** If an OPT-BST OR OPT-BST-E card is installed, complete the “[DLP-G79 Verify the OPT-BST, OPT-BST-E, or OPT-BST-L Amplifier Laser and Power](#)” task on page 4-5 on the west (or terminal) OPT-BST, OPT-BST-E or OPT-BST-L o ensure that the amplifier is working properly.
- Step 14** Complete the “[DLP-G80 Verify the OPT-PRE Amplifier Laser and Power](#)” task on page 4-6 on the west (or terminal) OPT-PRE card to ensure that the amplifier is working properly.
- Step 15** Complete the “[DLP-G78 Verify the 32MUX-O Card Power](#)” task on page 4-7 to verify that the 32MUX-O is powered correctly.
- Step 16** Complete the “[DLP-G269 Verify the 32DMX-O Card Power](#)” task on page 4-7 to verify that the 32DMX-O card is powered correctly.
- Step 17** Restore the default IS,AINS (ANSI) or Unlocked,automaticInService (ETSI) administrative state to the 32MUX-O port that was changed to **OOS,MT** (ANSI) or **Locked,maintenance** (ETSI) in [Step 11](#).
- Step 18** Repeat Steps [7](#) through [17](#) for the remaining 31 wavelengths of the 100-GHz grid to verify the correct behavior of all variable optical attenuators (VOAs) inside the 32MUX-O card.
- Step 19** Remove the loopback created in [Step 5](#).
- Step 20** If the node is a hub node, repeat Steps [5](#) through [19](#) for the east side cards.
- Step 21** Complete the “[NTP-G37 Run Automatic Node Setup](#)” procedure on page 3-82 to restore the original configuration.
- Step 22** Click the **Alarms** tab.
- Verify that the alarm filter is not on. See the “[DLP-G128 Disable Alarm Filtering](#)” task on page 8-28 as necessary.
 - Verify that no equipment alarms appear indicating equipment failure or other hardware problems. (Equipment alarms are indicated by an EQPT in the Alarms tab Cond column.) If equipment failure alarms appear, investigate and resolve them before continuing. Refer to the *Cisco ONS 15454 DWDM Troubleshooting Guide* for procedures.

Stop. You have completed this procedure.

DLP-G268 Provision TXP_MR_10E_C Cards for Acceptance Testing

Purpose	This procedure provisions a TXP_MR_10E_C card for acceptance testing when a tunable laser is not available.
Tools/Equipment	TXP_MR_10E_C
Prerequisite Procedures	NTP-G32 Install the Transponder and Muxponder Cards , page 3-50 NTP-G34 Install Fiber-Optic Cables on DWDM Cards and DCUs , page 3-56
Required/As Needed	As needed
Onsite/Remote	Onsite
Security Level	Superuser

- Step 1** If you have installed and verified the TXP_MR_10E_C card, continue with [Step 2](#). If not, install the TXP card using the “[NTP-G32 Install the Transponder and Muxponder Cards](#)” procedure on page 3-50.
- Step 2** Display the TXP_MR_10E_C in card view.

- Step 3** Click the **Provisioning > Line > SONET (ANSI) or SDH (ETSI)** tabs.
- Step 4** Click the **Admin State** column for the trunk port and choose **OOS,DSBLD (ANSI) or Locked,disabled (ETSI)** from the drop-down list.
- Step 5** Click **Apply**, then click **Yes**.
- Step 6** Click the **Provisioning > Line > Wavelength Trunk Settings** tabs.
- Step 7** In the Wavelength field, choose the first wavelength required by the acceptance test.
- Step 8** Click **Apply**.
- Step 9** Click the **Provisioning > Line > SONET (ANSI) or SDH (ETSI)** tabs.
- Step 10** Click the **Admin State** column for the trunk port and choose **OOS,MT (ANSI) or Locked,maintenance (ETSI)** from the drop-down list.
- Step 11** Click **Apply**.
- Step 12** Connect a power meter to the DWDM TX port. Verify that the output power falls within 4.5 dBm and + or – 1 dBm. If it does not fall within this range, replace the card or contact your next level of support.
- Step 13** Return to your originating procedure (NTP).

DLP-G79 Verify the OPT-BST, OPT-BST-E, or OPT-BST-L Amplifier Laser and Power

Purpose	This task verifies that the OPT-BST, OPT-BST-E, or OPT-BST-L amplifier laser is on and provisioned to the correct power.
Tools/Equipment	None
Prerequisite Procedures	DLP-G46 Log into CTC, page 2-25
Required/As Needed	As needed
Onsite/Remote	Onsite or remote
Security Level	Superuser

- Step 1** In node view (single-shelf mode) or shelf view (multishelf mode), double-click the OPT-BST, OPT-BST-E, or OPT-BST-L amplifier to display the card view.
- Step 2** Click the **Maintenance > ALS** tabs. If the value in the Currently Shutdown field is NO, continue with [Step 3](#). If not, complete the following steps:
- Check the optical safety remote interlock (OSRI) setting. If it is set to On, change it to **Off**. If the OSRI setting is set to Off and the Currently Shutdown field is Yes, contact your next level of support.
 - Click **Apply**, then click **Yes**.
 - Check the Currently Shutdown field. If it changes to NO, continue with [Step 3](#). If not, contact your next level of support. The amplifier might need to be replaced.
- Step 3** Click the **Provisioning > Opt Ampli Line > Parameters** tabs.
- Step 4** Click **Reset**.
- Step 5** Scroll to the right and locate the Signal Output Power parameter for Port 6 (LINE-TX). Verify that the Signal Output Power value is greater than or equal to 1.5 dBm.

If the Signal Output Power is not greater than or equal to 1.5 dBm, do not continue. Begin troubleshooting or contact your next level of support.

Step 6 Return to your originating procedure (NTP).

DLP-G80 Verify the OPT-PRE Amplifier Laser and Power

Purpose	This task verifies that the OPT-PRE amplifier laser is on and provisioned to the correct power.
Tools/Equipment	None
Prerequisite Procedures	DLP-G46 Log into CTC, page 2-25
Required/As Needed	As needed
Onsite/Remote	Onsite or remote
Security Level	Superuser

- Step 1** In node view (single-shelf view) or shelf view (multishelf view), double-click the OPT-PRE amplifier to display the card view.
- Step 2** Click the **Maintenance > ALS** tabs.
- Step 3** If the value shown in the Currently Shutdown field is NO, continue with [Step 4](#). If the OSRI value is set to On, change it to **Off**. If the OSRI setting is set to Off and the Currently Shutdown field is Yes, contact your next level of support. If not, complete the following steps:
- If the OSRI setting is set to ON, click the table cell and choose **OFF** from the drop-down list.
 - Click **Apply**, then click **Yes**.
 - Check the Currently Shutdown field. If it changes to NO, continue with [Step 4](#). If not, contact your next level of support. The amplifier might need to be replaced.
- Step 4** Click the **Provisioning > Opt Ampli Line > Parameters** tabs.
- Step 5** Locate the Signal Output Power parameter for Port 2 (COM-TX). Verify that the Signal Output Power value is greater than or equal to 1.5 dBm. If the Signal Output Power is greater than or equal to 1.5 dBm, continue with [Step 6](#). If the Signal Output Power is less than 1.5 dBm, check your connections and clean the fibers using the “[NTP-G115 Clean Fiber Connectors](#)” procedure on page 13-25. If this does not change the power value, consult your next level of support.
- Step 6** Scroll to the right to locate the DCU Insertion Loss parameter. Verify that the DCU Insertion Loss value is less than or equal to 10 dB.
- If the DCU Insertion Loss is greater than 10 dB, do not continue. Begin troubleshooting or contact your next level of support.
- Step 7** Return to your originating procedure (NTP).

DLP-G78 Verify the 32MUX-O Card Power

Purpose	This task verifies 32MUX-O card power.
Tools/Equipment	None
Prerequisite Procedures	DLP-G46 Log into CTC, page 2-25
Required/As Needed	As needed
Onsite/Remote	Onsite or remote
Security Level	Superuser

-
- Step 1** Display the 32MUX-O card in card view.
- Step 2** Click the **Provisioning > Optical Chn > Parameters** tabs.
- Step 3** Change the administrative state of the corresponding port to **OOS,MT** (ANSI) or **Locked,maintenance** (ETSI).
- Step 4** Click **Apply**, then click **Yes**.
- Step 5** Check that the value in the Power column for the port reaches the value shown in the VOA Power Ref column.
- Step 6** Return to your originating procedure (NTP).
-

DLP-G269 Verify the 32DMX-O Card Power

Purpose	This task verifies that the 32DMX-O card is provisioned to the correct power.
Tools/Equipment	None
Prerequisite Procedures	DLP-G46 Log into CTC, page 2-25
Required/As Needed	As needed
Onsite/Remote	Onsite or remote
Security Level	Superuser

-
- Step 1** Display the 32DMX-O card in card view.
- Step 2** Click the **Provisioning > Optical Chn > Parameters** tabs.
- Step 3** Change the administrative state for the appropriate port to **OOS,DSBLD** (ANSI) or **Locked,disabled** (ETSI).
- Step 4** Click **Apply**, then click **Yes**.
- Step 5** Verify that the value in the Power table cell is the same as the VOA Power Ref table cell value for the port under test.
- Step 6** (Optional) Connect a power meter to the CHAN TX 01 port through the patch panel. Verify that the physical optical power value coming from drop Port 1 on the west 32DMX-O card is consistent with the value read (the maximum allowed error is ± 0.5 dBm).

Step 7 Return to your originating procedure (NTP).

NTP-G42 Perform the Terminal Node with 32WSS and 32DMX Cards Acceptance Test

Purpose	This acceptance test verifies that a terminal node provisioned for C-band wavelengths is operating properly before you connect it to the network. The test verifies that each add/drop and pass-through port on the 32WSS and 32DMX cards operates properly and verifies the operation of the amplifiers. The test also checks the power levels at each transmit and receive port to ensure that power loss in the cabling is within tolerance. If MMU cards are installed, the test verifies that the MMU insertion loss doesn't impact add, drop, or pass-through circuits.
Tools/Equipment	One of the following: <ul style="list-style-type: none"> • A tunable laser • TXP_MR_10E_C An optical power meter or optical spectrum analyzer 1 bulk attenuator (10 dB) with LC connectors
Prerequisite Procedures	Chapter 3, “Turn Up a Node”
Required/As Needed	Required
Onsite/Remote	Onsite
Security Level	Superuser



Note

This procedure creates an optical loopback on the OPT-BST or OPT-BST-E line. An optical signal is sent from the 32WSS input (add) to the OPT-BST or OPT-BST-E common receive (RX) and back out the OPT-BST or OPT-BST-E transmit (TX) line. The OPT-BST or OPT-BST-E line receives the looped signal from the OPT-BST or OPT-BST-E TX. It then passes the signal to the OPT-BST or OPT-BST-E common TX and into the OPT-PRE common RX. The OPT-PRE sends the signal to the 32DMX. The optical signal from the tunable laser or TXP_MR_10E_C must pass successfully through the 32WSS and out the 32DMX.



Note

Optical power measurements require either a tunable laser or a multirate transponder to generate the proper optical wavelength. If multirate transponders were installed during completion of [Chapter 3, “Turn Up a Node,”](#) they can be used for this procedure. No additional cabling changes are needed.

- Step 1** Complete the “[DLP-G46 Log into CTC](#)” task on page 2-25 at the terminal node that you want to test. If you are already logged in, continue with [Step 2](#).
- Step 2** Display the terminal node in node view (single-shelf mode) or multishelf view (multishelf mode).
- Step 3** Click the **Alarms** tab.
- Verify that the alarm filter is not on. See the “[DLP-G128 Disable Alarm Filtering](#)” task on page 8-28 as necessary.

- b. Verify that no equipment alarms (indicated by EQPT in the Cond column) appear indicating equipment failure or other hardware problems. If equipment failure alarms appear, investigate and resolve them before continuing. Refer to the *Cisco ONS 15454 DWDM Troubleshooting Guide* for procedures.



Note If OSC terminations are created, an OSC channel alarm will appear.

Step 4 In node view (single-shelf mode) or multishelf view (multishelf mode), click the **Provisioning > WDM-ANS > Port Status** tabs. Verify that all statuses under Link Status are listed as Success - Changed, Success - Unchanged, or Not Applicable. If any are not, or if errors (indicated in red) appear, delete the OSC channels and complete the “[NTP-G37 Run Automatic Node Setup](#)” procedure on [page 3-82](#). Provision the OSC channels when complete.

Step 5 Create a physical loopback on the OPT-BST, OPT-BST-E, or OSC-CSM card by using a patchcord with 10-dB bulk attenuators to connect the LINE TX port to the LINE RX port.



Note A SDCC Termination Failure alarm will appear due to the OSC signal loopback. This is observed as an alarm on Port 1 of the OSCM or OSC-CSM card.

Step 6 Wait approximately two minutes, then verify that the OSC link is active on the west OSCM or OSC-CSM card by observing whether or not the loss of signal (LOS) alarm on the OSCM or OSC-CSM (and the OPT-BST or OPT-BST-E card, if present) clears. (The OSC termination must already be provisioned. If not, complete the “[NTP-G38 Provision OSC Terminations](#)” procedure on [page 3-83](#).)

Step 7 If you are using a tunable laser, follow the manufacturer’s instructions to complete the following steps. If you are using a TXP_MR_10E_C card, continue with [Step 8](#).

- a. Set the output power to a nominal value, such as -3 dBm.
- b. Set the tuner to the wavelength you will test, then continue with [Step 9](#).

Step 8 If you are using a TXP_MR_10E_C card, complete the “[DLP-G268 Provision TXP_MR_10E_C Cards for Acceptance Testing](#)” task on [page 4-4](#) for the TXP containing the wavelength you will test. Refer to [Table 4-1](#), if needed.

Step 9 Connect the tunable laser transmitter or the TXP_MR_10E_C card DWDM TX port to the CHAN RX 01 port on the 32WSS card using the available patch panel.



Note The tunable laser minimum output optical power (Pout) must be -6 dBm. If the output power is lower than -6 dBm, the 32WSS card might not reach the provisioned setpoint.

Step 10 Display the 32WSS card in card view.

Step 11 Click the **Provisioning > Optical Chn Optical Connector n > Parameters** tabs, where n = the optical connector number that carries the wavelengths you will test. Refer to [Table 4-1](#) on [page 4-21](#), if needed.

Step 12 Click the **Admin State** table cell for the add (CHAN-RX) port carrying the tested wavelength, then choose **OOS,MT** (ANSI) or **Locked,maintenance** (ETSI) from the drop-down list. For example, if the tested wavelength is 1530.33 nm (shown as 1530.3), you would click the Port 1 (CHAN-RX) Admin State field and choose OOS,MT or Locked,maintenance from the drop-down list.

Step 13 Change the administrative state of the pass-through port corresponding to the port in [Step 9](#) to **OOS,MT** (ANSI) or **Locked,maintenance** (ETSI). For example, if the tested wavelength is 1530.33 nm (shown as 1530.3), you would click the Port 33 (PASS-THROUGH) Admin State field and choose OOS,MT or Locked,maintenance from the drop-down list. Refer to [Table 4-1](#) on [page 4-21](#), if needed.

- Step 14** Click **Apply**, then click **Yes**.
- Step 15** Click the **Maintenance** tab.
- Step 16** For Channel #1, change Operating Mode to **Add Drop**.
- Step 17** Click **Apply**, then click **Yes**.
- Step 18** Click the **Provisioning > Optical Chn Optical Connector_n > Parameters** tabs, where *n* = the optical connector number that carries the wavelength under test.
- Step 19** Verify that the actual power coming from the tunable laser or TXP_MR_10E_C card shown under the Power column is equal to the specified VOA Power Ref power (+/- 0.2dB) shown in the same row.
- Step 20** Click the **Optical Line** tab.
- Step 21** Verify that the power value from Step 19 reaches the Shelf *i* Slot *i* (32WSS or 32DMX).Port COM-TX.Power set point +/- 1.0 dBm. To view this set point:
- In node view (single-shelf mode) or multishelf view (multishelf mode), click the **Provisioning > WDM-ANS > Provisioning** tabs.
 - In the Selector window on the left, expand the 32WSS or 32DMX card.
 - Expand the Port COM-TX category.
 - Select Power.
 - View the value of the Shelf *i* Slot *i* (32WSS or 32DMX).Port COM-TX.Power parameter on the right pane.
 - If the power value does not match the value recorded in Step 19 (+/- 0.5 dB), contact your next level of support.
- Step 22** If an OPT-BST or OPT-BST-E card is installed, complete the “[DLP-G79 Verify the OPT-BST, OPT-BST-E, or OPT-BST-L Amplifier Laser and Power](#)” task on page 4-5 on the OPT-BST or OPT-BST-E to ensure that the amplifier is working properly.
- Step 23** If an OSC- CSM is installed, continue with [Step 25](#). If an OPT-BST is installed, verify the connection between Port 67 (COM-TX) on the 32WSS and Port 1 (COM-RX) on the OPT-BST or OPT-BST-E cards:
- Display the 32WSS card in card view.
 - Click the **Provisioning > Optical Line** tabs.
 - Record the value in the Power table cell for Port 67 (COM-TX).
 - Display the OPT-BST or OPT-BST-E card in card view.
 - Click the **Provisioning > Optical Line > Parameters** tabs.
 - Verify that the value in the Power table cell for Port 1 (COM-RX) is equal to the value recorded in Step c, +/- 1.0 dB. If not, use the “[NTP-G115 Clean Fiber Connectors](#)” procedure on page 13-25 to clean the fiber connection between the OPT-BST or OPT-BST-E and 32WSS cards. Check the values again. If they still do not match, contact your next level of support.
- Step 24** If an OPT-BST, OPT-BST-E, or OPT-BST-L card is installed on the west or terminal side, complete the “[DLP-G79 Verify the OPT-BST, OPT-BST-E, or OPT-BST-L Amplifier Laser and Power](#)” task on page 4-5 to ensure the amplifier is working properly.
- Step 25** Complete the following steps to verify the connection between Port 67 (COM-TX) on the 32WSS and the Port 2 (COM-RX) on the OSC-CSM card:
- Display the 32WSS card in card view.
 - Click the **Provisioning > Optical Line** tabs.

- c. Record the value in Power table cell for Port 67 (COM-TX).
 - d. Display the OSC-CSM card in card view.
 - e. Click the **Provisioning > Optical Line > Parameters** tabs.
 - f. Verify that the value in the Power table cell for Port 2 (COM-RX) is equal to the value recorded in Step c, +/- 1.0 dB. If not, use the [“NTP-G115 Clean Fiber Connectors” procedure on page 13-25](#) to clean the fiber connection between the OSC-CSM and 32WSS cards. Check the values again. If they still do not match, contact your next level of support.
- Step 26** Complete the following steps to verify the connection between Port 2 (COM-TX) on the OPT-PRE card and Port 33(COM-RX) on the 32DMX card:
- a. Display the OPT-PRE card in card view.
 - b. Click the **Provisioning > OptAmpliLine > Parameters** tabs.
 - c. Record the value in Power table cell for Port 2 (COM-TX).
 - d. Display the 32DMX card in card view.
 - e. Click the **Provisioning > Optical Line > Parameters** tabs.
 - f. Verify that the value in the Power table cell for Port33 (COM-RX) is equal to the value recorded in Step c, +/- 1.0 dB. If not, use the [“NTP-G115 Clean Fiber Connectors” procedure on page 13-25](#) to clean the fiber connection between the OPT-PRE and 32DMX cards. Check the values again. If they still do not match, contact your next level of support.
- Step 27** Complete the [“DLP-G80 Verify the OPT-PRE Amplifier Laser and Power” task on page 4-6](#) on the OPT-PRE to ensure that the amplifier is working properly.
- Step 28** Complete the [“DLP-G270 Verify the 32DMX Power” task on page 4-12](#) to verify that the 32DMX card is powered correctly.
- Step 29** Display the 32WSS in card view.
- Step 30** Click the **Maintenance** tab.
- Step 31** For the circuit (channel) under test, click the **Operating Mode** table cell and choose **Not Assigned** from the drop-down list.
- Step 32** Click **Apply**, then **Yes**.
- Step 33** Click the **Provisioning > Optical Chn Optical Connector_n > Parameters** tabs, where *n* = the optical connector number that carries the wavelength under test.
- Step 34** Click the **Admin State** table cell. Choose **IS,AINS** (ANSI) or **Unlocked,automaticInService** (ETSI) from the drop-down list for all ports that were changed to OOS,MT or Locked,maintenance.
- Step 35** Repeat Steps 7 through 34 for the remaining 31 wavelengths of the 100-Ghz grid to verify the correct behavior of all VOAs inside the 32WSS card.
- Step 36** Disconnect the TXP card or tunable laser from the 32WSS card.
- Step 37** Remove the loopback created in Step 5.
- Step 38** Complete the [“NTP-G37 Run Automatic Node Setup” procedure on page 3-82](#) to restore the original configuration.
- Step 39** Click the **Alarms** tab.
- a. Verify that the alarm filter is not on. See the [“DLP-G128 Disable Alarm Filtering” task on page 8-28](#) as necessary.

- b. Verify that no equipment alarms appear indicating equipment failure or other hardware problems. (Equipment alarms are indicated by an EQPT in the Alarms tab Cond column.) If equipment failure alarms appear, investigate and resolve them before continuing. Refer to the *Cisco ONS 15454 DWDM Troubleshooting Guide* for procedures.

Stop. You have completed this procedure.

DLP-G270 Verify the 32DMX Power

Purpose	This task verifies that the 32DMX card is provisioned to the correct power.
Tools/Equipment	None
Prerequisite Procedures	DLP-G46 Log into CTC, page 2-25
Required/As Needed	As needed
Onsite/Remote	Onsite or remote
Security Level	Superuser

- Step 1** Display the 32DMX card in card view.
 - Step 2** Click the **Provisioning > Optical Line > Parameters** tabs.
 - Step 3** Change the administrative state for Port 33 (COM TX) to **OOS,MT** (ANSI) or **Locked,maintenance** (ETSI)
 - Step 4** Verify that the value shown in the VOA Power Ref column reaches the provisioned setpoint.
 - Step 5** (Optional) Connect a power meter to the CHAN TX 01 port through the patch panel. Verify that the physical optical power value coming from the 32DMX drop Port 1 is consistent with the Power value on the Parameters tab, +/- 1 dBm.
 - Step 6** Change the administrative state for Port 1 to **OOS,DSBLD** (ANSI) or **Locked,disabled** (ETSI).
 - Step 7** Return to your originating procedure (NTP).
-

NTP-G153 Perform the Terminal Node with 32WSS-L and 32DMX-L Cards Acceptance Test

Purpose	This acceptance test verifies that a terminal node provisioned for L-band wavelengths is operating properly before you connect it to the network. The test verifies that each add/drop and pass-through port on the 32WSS-L and 32DMX-L cards operates properly and verifies the operation of the amplifiers. The test also checks the power levels at each transmit and receive port to ensure that power loss in the cabling is within tolerance. If MMU cards are installed, the test verifies that the MMU insertion loss doesn't impact add, drop, or pass-through circuits.
Tools/Equipment	One of the following: <ul style="list-style-type: none"> • A tunable laser • TXP_MR_10E_L An optical power meter or optical spectrum analyzer 1 bulk attenuator (10 dB) with LC connectors
Prerequisite Procedures	Chapter 3, “Turn Up a Node”
Required/As Needed	Required
Onsite/Remote	Onsite
Security Level	Superuser

Note

Optical power measurements require either a tunable laser or a multirate transponder to generate the proper optical wavelength. If multirate transponders were installed during completion of [Chapter 3, “Turn Up a Node,”](#) they can be used for this procedure. No additional cabling changes are needed.

Note

This procedure creates an optical loopback on the OPT-BST-L line. An optical signal is sent from the 32WSS-L input (add) to the OPT-BST-L common RX and back out the OPT-BST-L TX line. The OPT-BST-L line receives the looped signal from the OPT-BST-L TX. It then passes the signal to the OPT-BST-L common TX and into the OPT-AMP-L (when provisioned in OPT-PRE mode) common RX. The OPT-AMP-L card sends the signal to the 32DMX-L card. The optical signal from the tunable laser or TXP_MR_10E_L card must pass successfully through the 32WSS-L card and out the 32DMX-L card.

- Step 1** Complete the [“DLP-G46 Log into CTC” task on page 2-25](#) at the hub or terminal node that you want to test. If you are already logged in, continue with [Step 2](#).
- Step 2** Display the terminal node in node view (single-shelf mode) or multishelf view (multishelf mode).
- Step 3** Click the **Alarms** tab.
- Verify that the alarm filter is not on. See the [“DLP-G128 Disable Alarm Filtering” task on page 8-28](#) as necessary.
 - Verify that no equipment alarms appear indicating equipment failure or other hardware problems. (Equipment alarms are indicated by an EQPT in the Alarms tab Cond column.) If equipment failure alarms appear, investigate and resolve them before continuing. Refer to the *Cisco ONS 15454 DWDM Troubleshooting Guide* for procedures.



Note If OSC terminations are created, an OSC channel alarm will appear.

Step 4 In node view (single-shelf mode) or multishelf view (multishelf mode), click the **Provisioning > WDM-ANS > Port Status** tabs. Verify that all statuses under Link Status are listed as Success - Changed, Success - Unchanged, or Not Applicable. If any are not, or if errors (indicated in red) appear, delete the OSC channels and complete the “[NTP-G37 Run Automatic Node Setup](#)” procedure on [page 3-82](#). Provision the OSC channels when complete.

Step 5 Create a physical loopback on the OPT-BST-L, OCSM, or OSC-CSM card by using a patchcord with 10-dB bulk attenuators to connect the LINE TX port to the LINE RX port.



Note An SDCC Termination Failure alarm will appear due to the OSC signal loopback. This is observed as an alarm on Port 1 of the OSCM or OSC-CSM card.

Step 6 Wait approximately two minutes, then verify that the OSC link is active on the west OSCM or OSC-CSM card by observing whether or not the LOS alarm on the OSCM or OSC-CSM card (and the OPT-BST-L card, if present) clears. (The OSC termination must already be provisioned. If not, complete the “[NTP-G38 Provision OSC Terminations](#)” procedure on [page 3-83](#).)

Step 7 If you are using a tunable laser, follow the manufacturer’s instructions to complete the following steps. If you are using a TXP_MR_10E_L card, continue with [Step 8](#).

- a. Set the output power to a nominal value, such as –3 dBm.
- b. Set the tuner to the wavelength you will test, then continue with [Step 9](#).

Step 8 If you are using a TXP_MR_10E_L card, complete the “[DLP-G358 Provision TXP_MR_10E_L Card for Acceptance Testing](#)” task on [page 4-16](#) for the TXP containing the wavelength you will test.

Step 9 Connect the tunable laser transmitter or the TXP_MR_10E_L card DWDM TX port to the CHAN RX 01 port on the 32WSS-L card using the available patch panel.



Note The tunable laser minimum Pout must be –6 dBm. If the output power is lower than –6 dBm, the 32WSS-L card might not reach the provisioned setpoint.

Step 10 Display the 32WSS-L card in card view.

Step 11 Click the **Provisioning > Optical Chn Optical Connector_n > Parameters** tabs, where *n* = the optical connector number that carries the wavelengths you will test. Refer to [Table 4-2 on page 4-43](#), if needed.

Step 12 Click the **Admin State** table cell for the add (CHAN-RX) port carrying the tested wavelength, then choose **OOS,MT (ANSI)** or **Locked,maintenance (ETSI)** from the drop-down list. For example, if the tested wavelength is 1577.86 nm (shown as 1577.8), you would click the Port 1 (CHAN-RX) Admin State field and choose OOS,MT or Locked,maintenance from the drop-down list.

Step 13 Change the administrative state of the pass-through port corresponding to the port in [Step 9](#) to **OOS,MT (ANSI)** or **Locked,maintenance (ETSI)**. For example, if the tested wavelength is 1577.86 nm (shown as 1577.86), you would click the Port 33 (PASS-THROUGH) Admin State field and choose OOS,MT or Locked,maintenance from the drop-down list. Refer to [Table 4-2 on page 4-43](#), if needed.

Step 14 Click the **Provisioning > Optical Chn Optical Connector_n > Parameters** tabs, where *n* = the optical connector number that carries the wavelength under test.

Step 15 Click **Apply**, then click **Yes**.

Step 16 Click the **Maintenance** tab.

- Step 17** For Channel #1, change Operating Mode to **Add Drop**.
- Step 18** Click **Apply**, then click **Yes**.
- Step 19** Click the **Provisioning > Optical Chn > Parameters** *n* tabs where *n* = the optical connector number that carries the wavelength under test.
- Step 20** Verify that the actual power coming from the tunable laser or TXP_MR_10E_L card shown under the Power column is equal to the specified VOA Power Ref power (+/- 0.2 dB) shown in the same row.
- Step 21** Click the **Optical Line** tab.
- Step 22** Verify that the TX COM port (#67) has the same Power column value as the VOA Power Ref setpoint (+/- 0.5 dB) in [Step 20](#). This verifies that the optical signal is traveling correctly through the 32WSS-L card.
- Step 23** If an OPT-BST-L card is installed, complete the [“DLP-G359 Verify the OPT-BST-L or OPT-AMP-L \(OPT-Line Mode\) Amplifier Laser and Power”](#) task on page 4-17 on the OPT-BST-L to ensure that the amplifier is working properly.
- Step 24** If an OSC- CSM is installed, continue with [Step 25](#). If an OPT-BST-L is installed, verify the connection between Port 67 (COM-TX) on the 32WSS-L and Port 1 (COM-RX) on the OPT-BST-L cards:
- Display the 32WSS-L card in card view.
 - Click the **Provisioning > Optical Line** tabs.
 - Record the value in the Power table cell for Port 67 (COM-TX).
 - Display the OPT-BST-L card in card view.
 - Click the **Provisioning > Optical Line > Parameters** tabs.
 - Verify that the value in the Power table cell for Port 1 (COM-RX) is equal to the value recorded in [Step c](#), +/- 1.0 dB. If not, use the [“NTP-G115 Clean Fiber Connectors”](#) procedure on page 13-25 to clean the fiber connection between the OPT-BST-L and 32WSS-L cards. Check the values again. If they still do not match, contact your next level of support.
- Step 25** If an OPT-BST-L card is installed on the west or terminal side, complete the [“DLP-G79 Verify the OPT-BST, OPT-BST-E, or OPT-BST-L Amplifier Laser and Power”](#) task on page 4-5 to ensure the amplifier is working properly.
- Step 26** Complete the following steps to verify the connection between Port 67 (COM-TX) on the 32WSS-L and the Port 2 (COM-RX) on the OSC-CSM card:
- Display the 32WSS-L card in card view.
 - Click the **Provisioning > Optical Line** tabs.
 - Record the value in Power table cell for Port 67 (COM-TX).
 - Display the OSC-CSM card in card view.
 - Click the **Provisioning > Optical Line > Parameters** tabs.
 - Verify that the value in the Power table cell for Port 2 (COM-RX) is equal to the value recorded in [Step c](#), +/- 1.0 dB. If not, use the [“NTP-G115 Clean Fiber Connectors”](#) procedure on page 13-25 to clean the fiber connection between the OSC-CSM and 32WSS-L cards. Check the values again. If they still do not match, contact your next level of support.
- Step 27** Complete the following steps to verify the connection between Port 2 (COM-TX) on the OPT-AMP-L card provisioned in OPT-PRE mode and Port 33(COM-RX) on the 32DMX-L card:
- Display the OPT-AMP-L card in card view.
 - Click the **Provisioning > OptAmpliLine > Parameters** tabs.
 - Record the value in Power table cell for Port 2 (COM-TX).

- d. Display the 32DMX-L card in card view.
 - e. Click the **Provisioning > Optical Line > Parameters** tabs.
 - f. Verify that the value in the Power table cell for Port33 (COM-RX) is equal to the value recorded in Step c, +/- 1.0 dB. If not, use the “[NTP-G115 Clean Fiber Connectors](#)” procedure on page 13-25 to clean the fiber connection between the OPT-AMP-L and 32DMX-L cards. Check the values again. If they still do not match, contact your next level of support.
- Step 28** Complete the “[DLP-G360 Verify the OPT-AMP-L \(OPT-PRE Mode\) Amplifier Laser and Power](#)” task on page 4-18 on the OPT-PRE to ensure that the amplifier is working properly.
- Step 29** Complete the “[DLP-G361 Verify the 32DMX-L Power](#)” task on page 4-19 to verify that the 32DMX card is powered correctly.
- Step 30** Display the 32WSS-L in card view.
- Step 31** Click the **Maintenance** tab.
- Step 32** For the circuit (channel) under test, click the **Operating Mode** table cell and choose **Not Assigned** from the drop-down list.
- Step 33** Click **Apply**, then **Yes**.
- Step 34** Click the **Provisioning > Optical Chn Optical Connector_n > Parameters** tabs, where *n* = the optical connector number that carries the wavelength under test.
- Step 35** Click the **Admin State** table cell. Choose **IS,AINS (ANSI)** or **Unlocked,automaticInService (ETSI)** from the drop-down list for all ports that were changed to OOS,MT or Locked,maintenance.
- Step 36** Repeat Steps 7 through 34 for the remaining 31 wavelengths of the 100-Ghz grid to verify the correct behavior of all VOAs inside the 32WSS-L card.
- Step 37** Disconnect the TXP card or tunable laser from the 32WSS-L card.
- Step 38** Remove the loopback created in Step 5.
- Step 39** Complete the “[NTP-G37 Run Automatic Node Setup](#)” procedure on page 3-82 to restore the original configuration.
- Step 40** Click the **Alarms** tab.
- a. Verify that the alarm filter is not on. See the “[DLP-G128 Disable Alarm Filtering](#)” task on page 8-28 as necessary.
 - b. Verify that no equipment alarms appear indicating equipment failure or other hardware problems. (Equipment alarms are indicated by an EQPT in the Alarms tab Cond column.) If equipment failure alarms appear, investigate and resolve them before continuing. Refer to the *Cisco ONS 15454 DWDM Troubleshooting Guide* for procedures.

Stop. You have completed this procedure.

DLP-G358 Provision TXP_MR_10E_L Card for Acceptance Testing

Purpose	This procedure provisions a TXP_MR_10E_L card for acceptance testing when a tunable laser is not available.
Tools/Equipment	TXP_MR_10E_L

Prerequisite Procedures	NTP-G32 Install the Transponder and Muxponder Cards, page 3-50 NTP-G34 Install Fiber-Optic Cables on DWDM Cards and DCUs, page 3-56
Required/As Needed	As needed
Onsite/Remote	Onsite
Security Level	Superuser

-
- Step 1** If you have installed and verified the TXP_MR_10E_L card, continue with [Step 2](#). If you have not installed it, install the card using the “[NTP-G32 Install the Transponder and Muxponder Cards](#)” procedure on [page 3-50](#).
- Step 2** Display the TXP_MR_10E_L card in card view.
- Step 3** Click the **Provisioning** > **Line** > *Service-Type* tabs.
- Step 4** Click the **Admin State** table cell for the trunk port and choose **OOS,DSBLD** (ANSI) or **Locked,disabled** (ETSI) from the drop-down list.
- Step 5** Click **Apply**, then click **Yes**.
- Step 6** Click the **Provisioning** > **Card** tabs.
- Step 7** In the Wavelength field, choose the first wavelength required by the acceptance test.
- Step 8** Click **Apply**.
- Step 9** Click the **Provisioning** > **Line** > *Service-Type* tabs.
- Step 10** Click the **Admin State** table cell for the trunk port and choose **OOS,MT** (ANSI) or **Locked,maintenance** (ETSI) from the drop-down list.
- Step 11** Click **Apply**, then click **Yes**.
- Step 12** Connect a power meter to the DWDM TX port. Verify that the output power falls within –4.5 dBm and 1 dBm. If it does not fall within this range, replace the card or contact your next level of support.
- Step 13** Repeat Steps [3](#) through [12](#) for all the installed TXP cards.
- Step 14** Return to your originating procedure (NTP).
-

DLP-G359 Verify the OPT-BST-L or OPT-AMP-L (OPT-Line Mode) Amplifier Laser and Power

Purpose	This task verifies that the OPT-BST-L or OPT-AMP-L (when provisioned in OPT-Line mode) amplifier laser is on and provisioned to the correct power.
Tools/Equipment	None
Prerequisite Procedures	DLP-G46 Log into CTC, page 2-25
Required/As Needed	As needed
Onsite/Remote	Onsite or remote
Security Level	Superuser

-
- Step 1** In node view (single-shelf mode) or shelf view (multishelf mode), double-click the OPT-BST-L or OPT-AMP-L amplifier to display the card view.
- Step 2** Click the **Maintenance > ALS** tabs. If the value in the Currently Shutdown field is NO, continue with [Step 3](#). If not, complete the following steps:
- Check the OSRI setting. If it is set to On, change it to **Off** and click **Apply**.
 - Check the Currently Shutdown field. If it changes to NO, continue with [Step 3](#). If not, contact your next level of support. The amplifier might need to be replaced.
- Step 3** Click the **Provisioning > Opt Ampli Line > Parameters** tabs.
- Step 4** Click **Reset**.
- Step 5** Scroll to the right and locate the Signal Output Power parameter for Port 6. Verify that the Signal Output Power value is greater than or equal to 1.5 dBm.
- If the Signal Output Power is not greater than or equal to 1.5 dBm, do not continue. Begin troubleshooting or contact your next level of support.
- Step 6** Return to your originating procedure (NTP).
-

DLP-G360 Verify the OPT-AMP-L (OPT-PRE Mode) Amplifier Laser and Power

Purpose	This task verifies that the OPT-AMP-L (when provisioned in OPT-PRE mode) amplifier laser is on and provisioned to the correct power.
Tools/Equipment	None
Prerequisite Procedures	DLP-G46 Log into CTC, page 2-25
Required/As Needed	As needed
Onsite/Remote	Onsite or remote
Security Level	Superuser

-
- Step 1** In node view (single-shelf view) or shelf view (multishelf view), double-click the OPT-AMP-L amplifier to display the card view.
- Step 2** Click the **Maintenance > ALS** tabs.
- Step 3** If the value shown in the Currently Shutdown field is NO, continue with [Step 4](#). If not, complete the following steps:
- If the OSRI setting is set to ON, click the table cell and choose **OFF** from the drop-down list.
 - Click **Apply**.
- Step 4** Click the **Provisioning > Opt Ampli Line > Parameters** tabs.
- Step 5** Locate the Signal Output Power parameter for Port 2. Verify that the Signal Output Power value is greater than or equal to 1.5 dBm. If the optical power is greater than or equal to 1.5 dBm, continue with [Step 6](#). If the optical power is less than 1.5 dBm, check your connections and clean the fibers using the [“NTP-G115 Clean Fiber Connectors” procedure on page 13-25](#). If this does not change the power value, consult your next level of support.
- Step 6** Scroll to the right to locate the DCU Insertion Loss parameter. Verify that the DCU Insertion Loss value is less than or equal to 10 dB.

If the optical power is not greater than or equal to 10 dB, do not continue. Begin troubleshooting or contact your next level of support.

Step 7 Return to your originating procedure (NTP).

DLP-G361 Verify the 32DMX-L Power

Purpose	This task verifies that the 32DMX-L card is provisioned to the correct power.
Tools/Equipment	None
Prerequisite Procedures	DLP-G46 Log into CTC, page 2-25
Required/As Needed	As needed
Onsite/Remote	Onsite or remote
Security Level	Superuser

- Step 1** Display the 32DMX-L card in card view.
- Step 2** Click the **Provisioning > Optical Chn > Parameters** tabs.
- Step 3** Change the administrative state for Port 33 to **OOS,MT** (ANSI) or **Locked,maintenance** (ETSI)
- Step 4** Verify that the VOA Power Ref reaches the provisioned setpoint.
- Step 5** (Optional) Connect a power meter to the CHAN TX 01 port through the patch panel. Verify that the physical optical power value coming from drop Port 1 on the west 32DMX card is consistent with the value read (the maximum allowed error is +/- 1 dBm).
- Step 6** Change the administrative state for Port 1 to **OOS,DSBLD** (ANSI) or **Locked,disabled** (ETSI).
- Step 7** Return to your originating procedure (NTP).
-

NTP-G43 Perform the ROADM Node with 32WSS and 32DMX Cards Acceptance Test

Purpose	This acceptance test verifies that a ROADM node provisioned for C-band wavelengths is operating properly before you connect it to the network. The test verifies that each add/drop and pass-through port on the 32WSS and 32DMX cards operates properly and verifies the operation of the amplifiers. The test also checks the power levels at each transmit and receive port to ensure that power loss in the cabling is within tolerance. If MMU cards are installed, the test verifies that the MMU insertion loss doesn't impact add, drop, or pass through circuits.
Tools/Equipment	One of the following: <ul style="list-style-type: none"> • A tunable laser • TXP_MR_10E_C An optical power meter or optical spectrum analyzer 2 bulk attenuators (10 dB) with LC connectors
Prerequisite Procedures	Chapter 3, "Turn Up a Node"
Required/As Needed	Required
Onsite/Remote	Onsite
Security Level	Superuser

**Note**

Optical power measurements require either a tunable laser or a multirate transponder to generate the proper optical wavelength. If multirate transponders were installed during completion of [Chapter 3, "Turn Up a Node,"](#) they can be used for this procedure. No additional cabling changes are needed.

**Note**

Because the node is isolated and no line-side fibers are connected during the test, the power levels going into the line-side cards will not be the same as the levels after the node is connected to the network. Therefore, if the ROADM shelf does not contain OPT-BST or OPT-BST-E and OPT-PRE amplifiers on both the east and west sides, you must lower the OPT-PRE power thresholds so that it turns on properly. At the end of the test, you will run automatic node setup (ANS) to configure the node with the correct parameters for the network acceptance test.

**Note**

Throughout this procedure, west refers to Slots 1 through 8, and east refers to Slots 10 through 17.

Step 1

Make a copy of [Table 4-1 on page 4-21](#) and place it in a convenient location for reference throughout this procedure. The table shows the 32WSS ports and the wavelengths assigned to them. The 32 wavelengths are divided among four physical multi-fiber push on (MPO) connectors on the 32WSS card. Each MPO connector is assigned eight wavelengths. In CTC, the MPO connector appears in the card view Provisioning > Optical Connector tab. Each Optical Connector subtab represents an MPO connector. Ports 1 through 32 are the RX (add) ports; Ports 33 through 64 are the pass-through ports.

Table 4-1 32WSS Ports and Wavelengths Test Checklist

32WSS Provisioning Subtab	Port #	Wavelength	Tested: Pass-Through	Tested: Add/Drop West	Tested: Add/Drop East
Optical Chn: Optical Connector 1	RX 1, PT 33	1530.33			
	RX 2, PT 34	1531.12			
	RX 3, PT 35	1531.90			
	RX 4, PT 36	1532.68			
	RX 5, PT 37	1534.25			
	RX 6, PT 38	1535.04			
	RX 7, PT 39	1535.82			
	RX 8, PT 40	1536.61			
Optical Chn: Optical Connector 2	RX 9, PT 41	1538.19			
	RX 10, PT 42	1538.98			
	RX 11, PT 43	1539.77			
	RX 12, PT 44	1540.56			
	RX 13, PT 45	1542.14			
	RX 14, PT 46	1542.94			
	RX 15, PT 47	1543.73			
	RX 16, PT 48	1544.53			
Optical Chn: Optical Connector 3	RX 17, PT 49	1546.12			
	RX 18, PT 50	1546.92			
	RX 19, PT 51	1547.72			
	RX 20, PT 52	1548.51			
	RX 21, PT 53	1550.12			
	RX 22, PT 54	1550.92			
	RX 23, PT 55	1551.72			
	RX 24, PT 56	1552.52			
Optical Chn: Optical Connector 4	RX 25, PT 57	1554.13			
	RX 26, PT 58	1554.94			
	RX 27, PT 59	1555.75			
	RX 28, PT 60	1556.55			
	RX 29, PT 61	1558.17			
	RX 30, PT 62	1558.98			
	RX 31, PT 63	1559.79			
	RX 32, PT 64	1560.61			

Step 2 Complete the “DLP-G46 Log into CTC” task on page 2-25 at the ROADM node that you want to test. If you are already logged in, continue with Step 3.

- Step 3** Display the ROADM node in node view (single-shelf mode) or multishelf view (multishelf mode).
- Step 4** Click the **Alarms** tab.
- Verify that the alarm filter is not on. See the “[DLP-G128 Disable Alarm Filtering](#)” task on page 8-28 as necessary.
 - Verify that no equipment alarms appear indicating equipment failure or other hardware problems. (Equipment alarms are indicated by an EQPT in the Alarms tab Cond column.) If equipment failure alarms appear, investigate and resolve them before continuing. Refer to the *Cisco ONS 15454 DWDM Troubleshooting Guide* for procedures.



Note The OSC terminations created during node turn-up will generate two alarms for each side of the shelf: one an LOS alarm on the OPT-BST or OPT-BST-E card, and the other an LOS alarm on the OSC-CSM or OSCM card. If OSCM cards are installed, SDCC termination failure (EOC) alarms will appear.

- Step 5** In node view (single-shelf mode) or multishelf view (multishelf mode), click the **Provisioning > WDM-ANS > Port Status** tabs. Verify that all statuses under Link Status are either Success - Changed, Success - Unchanged, or Not Applicable. If any are not, complete the following steps:
- Delete the two OSC channels using the “[DLP-G186 Delete an OSC Termination](#)” task on page 10-44.
 - Complete the “[NTP-G37 Run Automatic Node Setup](#)” procedure on page 3-82.
 - Create the OSC channels using the “[NTP-G38 Provision OSC Terminations](#)” procedure on page 3-83.
- Step 6** If MMU cards are installed, complete the following steps. If not, continue with [Step 7](#).
- Display the east MMU in card view.
 - Click the **Provisioning > Optical Line > Parameters** tabs.
 - Click the **Admin State** table cell for the COM RX, COM TX, EXP RX, and EXP TX ports and choose **OOS,MT** (ANSI) or **Locked,maintenance** (ETSI) from the drop-down list.
 - Click **Apply**, then click **Yes** to confirm.
 - Display the west MMU in card view.
 - Click the **Provisioning > Optical Line > Parameters** tabs.
 - Click the **Admin State** table cell for the COM RX, COM TX, EXP RX, and EXP TX ports and choose **OOS,MT** (ANSI) or **Locked,maintenance** (ETSI) from the drop-down list.
- Step 7** Display the east 32WSS in card view.
- Step 8** Click the **Provisioning > Optical Chn Optical Connector_n > Parameters** tabs, where *n* = the optical connector number that carries the wavelengths you will test. Refer to [Table 4-1 on page 4-21](#), if needed.
- Step 9** Click the **Admin State** table cell for the add port carrying the tested wavelength, then choose **OOS,MT** (ANSI) or **Locked,maintenance** (ETSI) from the drop-down list. For example, if the tested wavelength is 1530.33 nm (shown as 1530.3), you would click the Port 1 (CHAN-RX) Admin State field and choose OOS,MT or Locked,maintenance from the drop-down list.
- Step 10** Change the administrative state of the pass-through port corresponding to the port in [Step 9](#) to **OOS,MT** (ANSI) or **Locked,maintenance** (ETSI). For example, if the tested wavelength is 1530.33 nm (shown as 1530.3), you would click the Port 33 (PASS-THROUGH) Admin State field and choose OOS,MT or Locked,maintenance from the drop-down list. Refer to [Table 4-1 on page 4-21](#), if needed.
- Step 11** Click **Apply**, then click **Yes** to confirm.

- Step 12** Repeat Steps 8 through 11 for all wavelengths that you will test.
- Step 13** Display the west 32WSS in card view.
- Step 14** Repeat Steps 8 through 12 for the west 32WSS card.
- Step 15** Display the east 32DMX card in card view and complete the following steps:
- Choose the **Provisioning > Optical Line > Parameters** tabs.
 - For Port 33 (COM-RX), click the **Admin State** table cell and choose **OOS,MT** (ANSI) or **Locked,maintenance** (ETSI) from the drop-down list.
 - Click **Apply**, then click **Yes** to confirm.
- Step 16** Repeat Step 15 for the west 32DMX card.
- Step 17** Complete the “DLP-G310 Verify ROADM Node C-Band Pass-Through Channels” task on page 4-24.
- Step 18** Complete the following tasks for channels that will be added or dropped on the node.
- DLP-G311 Verify the East ROADM C-Band Add/Drop Channels, page 4-32
 - DLP-G312 Verify the West ROADM C-Band Add/Drop Channels, page 4-37
- Step 19** If MMU cards are installed, complete the following steps. If not, continue with Step 20.
- Display the east MMU in card view.
 - Click the **Provisioning > Optical Line > Parameters** tabs.
 - Click **Admin State** for the COM RX, COM TX, EXP RX, and EXP TX ports and choose **IS,AINS** (ANSI) or **Unlocked,automaticInService** (ETSI) from the drop-down list.
 - Click **Apply**, then click **Yes** to confirm.
 - Display the west MMU in card view.
 - Click the **Provisioning > Optical Line > Parameters** tabs.
 - Click **Admin State** for the COM RX, COM TX, EXP RX, and EXP TX ports and choose **IS,AINS** (ANSI) or **Unlocked,automaticInService** (ETSI) from the drop-down list.
- Step 20** Display the east 32WSS in card view.
- Step 21** Click the **Provisioning > Optical Chn Optical Connector_n > Parameters** tabs, where *n* = the optical connector number that carries the wavelengths you tested.
- Step 22** Click the **Admin State** table cell then choose **IS,AINS** (ANSI) or **Unlocked,automaticInService** (ETSI) from the drop-down list for all ports that were changed to OOS,MT or Locked,Maintenance in Steps 9 and 10.
- Step 23** Click **Apply**.
- Step 24** Repeat Steps 21 through 23 for all the ports that are in OOS,MT or Locked,maintenance state on the east 32WSS card.
- Step 25** Display the west 32WSS in card view.
- Step 26** Repeat Steps 21 through 24 for all ports on the west 32WSS card.
- Step 27** Display the east 32DMX in card view.
- Step 28** Choose the **Provisioning > Optical Line > Parameters** tabs.
- Step 29** For Port 33, click the **Admin State** table cell and choose **IS,AINS** (ANSI) or **Unlocked,automaticInService** (ETSI) from the drop-down list.
- Step 30** Click **Apply**.
- Step 31** Display the west 32DMX card in card view.

- Step 32** Repeat Steps 28 through 30 for the west 32DMX card.
- Step 33** Delete both OSC channels using the “[DLP-G186 Delete an OSC Termination](#)” task on page 10-44.
- Step 34** Complete the “[NTP-G37 Run Automatic Node Setup](#)” procedure on page 3-82.
- Step 35** Create the two OSC channels using the “[NTP-G38 Provision OSC Terminations](#)” procedure on page 3-83.
- Step 36** Click the **Alarms** tab.
- Verify that the alarm filter is not on. See the “[DLP-G128 Disable Alarm Filtering](#)” task on page 8-28 as necessary.
 - Verify that no equipment failure alarms appear on the node. If alarms appear, investigate and resolve them before continuing. Refer to the *Cisco ONS 15454 DWDM Troubleshooting Guide* for procedures.

Stop. You have completed this procedure.

DLP-G310 Verify ROADM Node C-Band Pass-Through Channels

Purpose

This task verifies the signal flow through a ROADM node for C-band pass-through channels. Pass-through channels pass through both 32WSS cards. The channels pass through the first 32WSS from the COM-RX port to the EXP-TX port. In the second 32WSS, the channel goes from the EXP-RX port to the COM-TX port. The channel is not terminated inside the node. If MMU cards are installed, the channel passes through the MMU COM-RX and EXP-TX ports to the 32WSS COM-RX and EXP-TX ports on one side. On the other side, the channel goes from the 32WSS EXP-RX and COM-TX ports to the MMU EXP-RX and COM-TX ports.

Tools/Equipment

One of the following:

- A tunable laser
- TXP_MR_10E_C

An optical power meter or optical spectrum analyzer

2 bulk attenuators (10 dB) with LC connectors

Prerequisite Procedures “[DLP-G46 Log into CTC](#)” task on page 2-25

Required/As Needed Required

Onsite/Remote Onsite

Security Level Superuser



Note

Throughout this task, west refers to Slots 1 through 8, and east refers to Slots 10 through 17.



Note

This task assumes OSC terminations were created. If not, complete the “[NTP-G38 Provision OSC Terminations](#)” procedure on page 3-83 before continuing.

- Step 1** Create a physical loopback on the west OPT-BST, OPT-BST-E, or OSC-CSM card by connecting the LINE TX port to its LINE RX port. For OPT-BST or OPT-BST-E cards, connect a 10-dB bulk attenuator to the fiber. (OSC-CSM cards do not require attenuation.)



Caution Failure to use proper attenuation might damage equipment.

- Step 2** If an OPT-PRE amplifier is installed on the west side (where the physical loopback was created), perform the following steps. If not, continue with [Step 3](#).
- Display the OPT-PRE card in card view, then click the **Provisioning > Optical Line > Optics Thresholds** tabs.
 - Under Types, click **Alarm**, then click **Refresh**. The alarm thresholds for the OPT-PRE card will appear.
 - Double-click the **Power Failure Low** table cell for Port 1 (COM-RX) and delete the current value.
 - Type a new value of **-30.0** and press **Enter** on your computer.
 - On the CTC window, click **Apply**, then click **Yes** on the confirmation dialog box.
- Step 3** If an OPT-PRE card is installed on the east side, complete the following steps. If an OPT-PRE card is not installed on the east side, continue with [Step 4](#).
- Display the east OPT-PRE card in card view, then click the **Provisioning > Optical Line > Optics Thresholds** tabs.
 - Under Types, click **Alarm**, then click **Refresh**. The alarm thresholds for the OPT-PRE card will appear.
 - Double-click the **Power Failure Low** table cell for Port 1 (COM-RX) and delete the current value.
 - Type a new value of **-30.0** and press **Enter** on your computer.
 - On the CTC window, click **Apply**, then click **Yes** on the confirmation dialog box.
- Step 4** Wait 2 to 3 minutes, then in node view (single-shelf mode) or multishelf view (multishelf mode) click the **Alarms** tab. Verify that the LOS alarms on the west OSCM or OSC-CSM card and the OPT-BST or OPT-BST-E card have cleared. The clearing of the LOS alarms indicates that the OSC link is active on the west side. If the alarms do not clear, contact your next level of support.



Note A SDCC Termination Failure alarm will continue to appear due to the OSC signal loopback.

- Step 5** Display the west 32WSS card in card view.
- Step 6** Click the **Maintenance** tab.
- Step 7** Click the **Operating Mode** table cell for the wavelength under test and choose **Pass Through** from the drop-down list.
- Step 8** Click **Apply**, then click **Yes** to confirm.
- Step 9** Display the east 32WSS card in card view.
- Step 10** Repeat Steps [6](#) through [8](#) for the east 32WSS card.
- Step 11** If you are using a tunable laser, follow the manufacturer's instructions to complete the following steps. If you are using a TXP_MR_10E_C card, continue with [Step 12](#).
- Set the output power to a nominal value, such as **-3 dBm**.
 - Set the tuner to the wavelength you will test, then continue with [Step 13](#).

- Step 12** If you are using a TXP_MR_10E_C card, complete the “[DLP-G268 Provision TXP_MR_10E_C Cards for Acceptance Testing](#)” task on page 4-4 for the TXP containing the wavelength you will test.
- Step 13** Connect the tunable laser transmitter or the TXP_MR_10E_C card DWDM TX port to the east OPT-BST, OPT-BST-E, or OSC-CSM LINE RX port. If an east OPT-PRE is installed, insert a 10-dB attenuator on the fiber coming from the TXP_MR_10E_C card.



Caution Failure to use proper attenuation might damage equipment.

- Step 14** If an OPT-PRE card is installed on the east side, complete the following steps. If not, continue with [Step 15](#).
- Display the east OPT-PRE in card view.
 - Click the **Provisioning > Optical Line > Parameters** tabs.
 - Locate the Power parameter for Port 1 (COM-RX). Record the value.
 - Display the east OPT-BST, OPT-BST-E, or OSC-CSM card in card view.
 - Click the **Provisioning > Optical Line > Parameters** tabs.
 - Locate the Power value for Port 2 (COM-TX) (OPT-BST or OPT-BST-E) or Port 3 (COM-TX) (OSC-CSM). Verify that the value matches the power recorded in Step [c](#), +/- 2.0 dB. If not, use the “[NTP-G115 Clean Fiber Connectors](#)” procedure on page 13-25 to clean the fiber connection between the OPT-PRE card and the OPT-BST, OPT-BST-E, or OSC-CSM card. Check the values again. If they still do not match, contact your next level of support.
 - For the east OPT-PRE card, complete the “[DLP-G80 Verify the OPT-PRE Amplifier Laser and Power](#)” task on page 4-6.
- Step 15** If an MMU card is installed on the east side, complete the following steps, then continue with [Step 17](#). If an MMU card is not installed, continue with [Step 16](#).
- Display the east MMU card in card view.
 - Click the **Provisioning > Optical Line > Parameters** tabs.
 - Locate the Port 3 (COM-RX) power parameter. Record the value.
 - If an east OPT-PRE card is installed, display it in card view and complete Step [e](#). If not, continue with Step [f](#).
 - Click the OPT-PRE **Provisioning > Opt.Ampli.Line > Parameters** tabs and read the Total Output Power value for Port 2 (COM-TX), then continue with Step [i](#).
 - If an east OPT-BST or OPT-BST-E card is installed, display it in card view and complete Step [g](#). If not, continue with Step [h](#).
 - Click the **Provisioning > Optical Line > Parameters** tabs and read the Power value for Port 2 (COM-TX), then continue with Step [i](#).
 - Display the east OSC-CSM card in card view, click the **Provisioning > Optical Line > Parameters** tabs and read the Power value for Port 3 (COM-TX), then continue with Step [i](#).
 - Verify that value in the Step [e](#), [g](#), or [h](#) matches the power recorded in Step [c](#), +/- 1.0 dB. If not, use the “[NTP-G115 Clean Fiber Connectors](#)” procedure on page 13-25 to clean the fiber connection between the MMU card and the OPT-BST, OPT-BST-E, OPT-PRE, or OSC-CSM cards. Check the values again. If they still do not match, contact your next level of support.
 - Display the east MMU card in card view.
 - Click the **Provisioning > Optical Line > Parameters** tabs.

- l. Record the value in the Power table cell for Port 2(EXP-TX) of the east MMU card.
 - m. Display the east 32WSS card in card view.
 - n. Click the **Provisioning > Optical Line > Parameters** tabs.
 - o. Verify that the value in the Power table cell for Port 68 (COM-RX) is equal to the value recorded in Step l, +/- 1.0 dB. If not, use the “[NTP-G115 Clean Fiber Connectors](#)” procedure on page 13-25 to clean the fiber connection between the 32WSS and MMU cards. Check the values again. If they still do not match, contact your next level of support.
 - p. Continue with Step 17.
- Step 16** Verify the east 32WSS to OPT-BST, OPT-PRE, or OSC-CSM cable connection:
- a. Display the east 32WSS in card view.
 - b. Click the **Provisioning > Optical Line > Parameters** tabs.
 - c. Locate the Port 68 (COM-RX) Power parameter. Record the value.
 - d. If an east OPT-PRE card is installed, display it in card view and complete Step e. If not, continue with Step f.
 - e. Click the **Provisioning > Opt.Ampli.Line > Parameters** tabs and read the Total Output Power value for Port 2 (COM-TX), then continue with Step i.
 - f. If an OPT-BST or OPT-BST-E card is installed on the east side, display it in card view and complete Step g. If not, continue with Step h.
 - g. Click the **Provisioning > Optical Line > Parameters** tabs and read the Power value for Port 2 (COM-TX), then continue with Step i.
 - h. Display the east OSC-CSM card in card view, click the **Provisioning > Optical Line > Parameters** tabs and read the Power value for Port 3 (COM-TX), then continue with Step i.
 - i. Verify that the value in Step e, g, or h matches the power recorded in Step c, +/- 1.5 dB. If not, use the “[NTP-G115 Clean Fiber Connectors](#)” procedure on page 13-25 to clean the fiber connection between the 32WSS card and the OPT-PRE, OPT-BST, OPT-BST-E, or OSC-CSM card. Check the values again. If they still do not match, contact your next level of support.
- Step 17** Verify the EXPRESS cable connection between the two 32WSS cards:
- a. Display the east 32WSS in card view.
 - b. Click the **Provisioning > Optical Line > Parameters** tabs.
 - c. Locate the Port 65 (EXP-TX) Power parameter. Record the value.
 - a. Display the west 32WSS in card view.
 - b. Click the **Provisioning > Optical Line > Parameters** tabs.
 - c. Locate the Power value for EXPRESS Port 66 (EXP-RX). Verify that the value matches the power recorded in Step c, +/-1 dB. If not, use the “[NTP-G115 Clean Fiber Connectors](#)” procedure on page 13-25 to clean the fiber connection between the 32WSS cards. Check the values again. If they still do not match, contact your next level of support.
- Step 18** Display the west 32WSS card in card view.
- Step 19** Click the **Provisioning > Optical Chn Optical Connector_n > Parameters** tabs, where n = the connector number containing the wavelength you are testing. Refer to [Table 4-1 on page 4-21](#), if needed.
- Step 20** Wait 60 to 70 seconds (or click **Reset**), then locate the Power and VOA Power Ref parameters for the tested PASS-THROUGH port. Verify that the Power value is equal to the VOA Power Ref value, +/- 1.5 dBm. If the Power value is not equal to the VOA Power Ref value +/-1.5 dBm, contact your next level of support.

- Step 21** If an MMU card is installed on the west side, complete the following steps. If an MMU card is not installed on the west side, continue with [Step 22](#).
- Display the west 32WSS card in card view.
 - Click the **Provisioning > Optical Line > Parameters** tabs.
 - Record the value in the Power table cell for Port 67(COM-TX).
 - Display the west MMU card in card view.
 - Click the **Provisioning > Optical Line > Parameters** tabs.
 - Verify that the value in the Power table cell for Port 1(EXP-RX) is equal to the value recorded in Step c, +/- 1.0 dB. If not, use the “[NTP-G115 Clean Fiber Connectors](#)” procedure on page 13-25 to clean the fiber connection between the 32WSS and MMU cards. Check the values again. If they still do not match, contact your next level of support.
 - Record the value in the Power table cell for Port 4 (COM-TX).
 - If a west OPT-BST or OPT-BST-E card is installed, display it in card view and complete Step i. If not, continue with Step j.
 - Click the **Provisioning > Optical Line > Parameters** tabs and read the Power value for Port 1 (COM-RX), then continue with Step k.
 - Display the west OSC-CSM card in card view, click the **Provisioning > Optical Line > Parameters** tabs and read the Power value for Port 2 (COM-RX), then continue with Step k.
 - Verify that the value in Step i or j matches the power recorded in Step g, +/- 1.5 dB. If not, use the “[NTP-G115 Clean Fiber Connectors](#)” procedure on page 13-25 to clean the fiber connection between the OPT-BST, OPT-BST-E, or OSC-CSM and MMU cards. Check the values again. If they still do not match, contact your next level of support.
 - Continue with [Step 23](#).
- Step 22** If an OPT-BST, OPT-BST-E, or OSC-CSM card is installed on the west side, complete the following steps. If not, continue with [Step 23](#).
- Display the west OPT-BST, OPT-BST-E, or OSC-CSM in card view.
 - Click the **Provisioning > Optical Line > Parameters** tabs.
 - Locate the Port 1 (COM-RX) Power parameter (OPT-BST or OPT-BST-E cards) or the Port 2 (COM-RX) Power parameter (OSC-CSM cards). Record the value.
 - Display the west 32WSS in card view.
 - Click the **Provisioning > Optical Line > Parameters** tabs.
 - Locate the Power value for Port 67 (COM-TX). Verify that the value matches the power recorded in Step c, +/-1 dB. If not, use the “[NTP-G115 Clean Fiber Connectors](#)” procedure on page 13-25 to clean the fiber connection between the OPT-BST, OPT-BST-E, or OSC-CSM card and the 32WSS card. Check the values again. If they still do not match, contact your next level of support.
 - For the west OPT-BST or OPT-BST-E card, complete the “[DLP-G79 Verify the OPT-BST, OPT-BST-E, or OPT-BST-L Amplifier Laser and Power](#)” task on page 4-5.
- Step 23** If a OPT-PRE card is installed on the west side, complete the following steps. If not, continue with [Step 24](#).
- Display the west OPT-PRE in card view.
 - Click the **Provisioning > Optical Line > Parameters** tabs.
 - Locate the Port 1 (COM-RX) Power parameter. Record the value.
 - Display the west OPT-BST, OPT-BST-E, or OSC-CSM card in card view.

- e. Click the **Provisioning > Optical Line > Parameters** tabs.
- f. Locate the Power value for Port 2 (COM-TX) (OPT-BST or OPT-BST-E) or Port 3 (COM-TX) (OSC-CSM). Verify that the value matches the power recorded in Step c, +/- 2.0 dB. If not, use the [“NTP-G115 Clean Fiber Connectors” procedure on page 13-25](#) to clean the fiber connection between the OPT-PRE card and the OPT-BST, OPT-BST-E, or OSC-CSM card. Check the values again. If they still do not match, contact your next level of support.
- g. For the west OPT-PRE, complete the [“DLP-G80 Verify the OPT-PRE Amplifier Laser and Power” task on page 4-6](#).

Step 24 If an MMU card is installed on the west side, complete the following steps, then continue with [Step 26](#). If an MMU card is not installed on the west side, continue with [Step 25](#).

- a. Display the west MMU card in card view.
- b. Click the **Provisioning > Optical Line > Parameters** tabs.
- c. Locate the Port 3 (COM-RX) power parameter. Record the value.
- d. If an west OPT-PRE card is installed, display it in card view and complete Step e. If not, continue with Step f.
- e. Click the OPT-PRE **Provisioning > Opt.Ampli.Line > Parameters** tabs and read the Total Output Power value for Port 2 (COM-TX), then continue with Step i.
- f. If an west OPT-BST or OPT-BST-E card is installed, display it in card view and complete Step g. If not, continue with Step h.
- g. Click the **Provisioning > Optical Line > Parameters** tabs and read the Power value for Port 2 (COM-TX), then continue with Step i.
- h. Display the west OSC-CSM card in card view, click the **Provisioning > Optical Line > Parameters** tabs and read the Power value for Port 3 (COM-TX), then continue with Step i.
- i. Verify that value in the Step e, g, or h matches the power recorded in Step c, +/- 1.0 dB. If not, use the [“NTP-G115 Clean Fiber Connectors” procedure on page 13-25](#) to clean the fiber connection between the MMU card and the OPT-BST, OPT-BST-E, OPT-PRE, or OSC-CSM cards. Check the values again. If they still do not match, contact your next level of support.
- j. Display the east MMU card in card view.
- k. Click the **Provisioning > Optical Line > Parameters** tabs.
- l. Record the value in the Power table cell for Port 2(EXP-TX) of the west MMU card.
- m. Display the west 32WSS card in card view.
- n. Click the **Provisioning > Optical Line > Parameters** tabs.
- o. Verify that the value in the Power table cell for Port 68 (COM-RX) is equal to the value recorded in Step l, +/- 1.0 dB. If not, use the [“NTP-G115 Clean Fiber Connectors” procedure on page 13-25](#) to clean the fiber connection between the 32WSS and cards and the MMU cards. Check the values again. If they still do not match, contact your next level of support.
- p. Continue with [Step 26](#).

Step 25 Verify the west 32WSS card to OPT-BST, OPT-BST-E, OPT-PRE, or OSC-CSM card cable connection:

- a. Display the west 32WSS in card view.
- b. Click the **Provisioning > Optical Line > Parameters** tabs.
- c. Locate the Port 68 (COM-RX) Power parameter. Record the value.
- d. If a west OPT-PRE card is installed, display it in card view and complete Step e. If not, continue with Step f.

- e. Click the **Provisioning > Opt.Ampli.Line > Parameters** tabs and read the Total Output Power value for Port 2 (COM-TX), then continue with Step **i**.
- f. If an west OPT-BST or OPT-BST-E card is installed, display it in card view and complete Step **g**. If not, continue with Step **h**.
- g. Click the **Provisioning > Optical Line > Parameters** tabs and read the Power value for Port 2 (COM-TX), then continue with Step **i**.
- h. Display the west OSC-CSM card in card view, click the **Provisioning > Optical Line > Parameters** tabs and read the Power value for Port 3 (COM-TX), then continue with Step **i**.
- i. Verify that the value in Step **e**, **g**, or **h** matches the power recorded in Step **c**, +/- 1.5 dB. If not, use the “[NTP-G115 Clean Fiber Connectors](#)” procedure on page 13-25 to clean the fiber connection between the 32WSS card and the OPT-PRE, OPT-BST, OPT-BST-E, or OSC-CSM card. Check the values again. If they still do not match, contact your next level of support.

Step 26 Verify the EXPRESS cable connection between the two 32WSS cards:

- a. Display the west 32WSS card in card view.
- b. Click the **Provisioning > Optical Line > Parameters** tabs.
- c. Locate the Port 65 (EXP-TX) Power parameter. Record the value.
- a. Display the east 32WSS card in card view.
- b. Click the **Provisioning > Optical Line > Parameters** tabs.
- c. Locate the Power value for Port 66 (EXP-RX). Verify that the value matches the power recorded in Step **c**, +/- 1 dB. If not, use the “[NTP-G115 Clean Fiber Connectors](#)” procedure on page 13-25 to clean the fiber connection between the 32WSS cards. Check the values again. If they still do not match, contact your next level of support.

Step 27 Display the east 32WSS card in card view.

Step 28 Click the **Provisioning > Optical Chn Optical Connector n > Parameters** tabs, where n = the connector number containing the wavelength you are testing. Refer to [Table 4-1 on page 4-21](#), if needed.

Step 29 Wait 60 to 70 seconds (or click **Reset**), then locate the Power and VOA Power Ref parameters for the tested PASS-THROUGH port. Verify that the Power value is equal to the VOA Power Ref value, +/- 1.5 dBm. If the Power value is not equal to the VOA Power Ref value +/- 1.5 dBm, consult your next level of support.

Step 30 If an MMU card is installed on the east side, complete the following steps. If an MMU card is not installed on the east side, continue with [Step 31](#).

- a. Display the east 32WSS card in card view.
- b. Click the **Provisioning > Optical Line > Parameters** tabs.
- c. Record the value in the Power table cell for Port 67(COM-TX).
- d. Display the east MMU card in card view.
- e. Click the **Provisioning > Optical Line > Parameters** tabs.
- f. Verify that the value in the Power table cell for Port 1(EXP-RX) is equal to the value recorded in Step **c**, +/- 1.0 dB. If not, use the “[NTP-G115 Clean Fiber Connectors](#)” procedure on page 13-25 to clean the fiber connection between the 32WSS and MMU cards. Check the values again. If they still do not match, contact your next level of support.
- g. Record the value in the Power table cell for Port 4 (COM-TX).
- h. If a east OPT-BST or OPT-BST-E card is installed, display it in card view and complete Step **i**. If not, continue with Step **j**.

- i. Click the **Provisioning > Optical Line > Parameters** tabs and read the Power value for Port 1 (COM-RX), then continue with Step [k](#).
 - j. Display the east OSC-CSM card in card view, click the **Provisioning > Optical Line > Parameters** tabs and read the Power value for Port 2 (COM-RX), then continue with Step [k](#).
 - k. Verify that the value in Step [i](#) or [j](#) matches the power recorded in Step [g](#), +/- 1.5 dB. If not, use the “[NTP-G115 Clean Fiber Connectors](#)” procedure on page 13-25 to clean the fiber connection between the OPT-BST, OPT-BST-E, or OSC-CSM and MMU cards. Check the values again. If they still do not match, contact your next level of support.
 - l. Continue with [Step 32](#).
- Step 31** If an OPT-BST, OPT-BST-E, or OSC-CSM card is installed on the east side, complete the following steps. If not, continue with [Step 32](#).
- a. Display the east OPT-BST, OPT-BST-E, or OSC-CSM card in card view.
 - b. Click the **Provisioning > Optical Line > Parameters** tabs.
 - c. Locate the Port 1 (COM-RX) Power parameter (OPT-BST or OPT-BST-E cards) or the Port 2 (COM-RX) Power parameter (OSC-CSM cards). Record the value.
 - d. Display the east 32WSS card in card view.
 - e. Click the **Provisioning > Optical Line > Parameters** tabs.
 - f. Locate the Power value for Port 67 (COM-TX). Verify that the value matches the power recorded in Step [c](#), +/-1 dB. If not, use the “[NTP-G115 Clean Fiber Connectors](#)” procedure on page 13-25 to clean the fiber connection between the OPT-BST, OPT-BST-E, or OSC-CSM and 32WSS cards. Check the values again. If they still do not match, contact your next level of support.
 - g. For the east OPT-BST or OPT-BST-E card, complete the “[DLP-G79 Verify the OPT-BST, OPT-BST-E, or OPT-BST-L Amplifier Laser and Power](#)” task on page 4-5.
- Step 32** Complete Steps [18](#), [19](#), [27](#), and [28](#) for the additional wavelengths that you want to test. If you have tested all the wavelengths, continue with [Step 33](#).
- Step 33** Display the east 32WSS card in card view.
- Step 34** Click the **Maintenance** tab.
- Step 35** Under Operating Mode, click the table cell and choose **Not Assigned** from the drop-down list for all wavelengths.
- Step 36** Click **Apply**, then click **Yes** to confirm.
- Step 37** Display the west 32WSS card in card view.
- Step 38** Repeat Steps [34](#) through [36](#) for the west 32WSS card.
- Step 39** Disconnect the TXP or tunable laser from the east OPT-BST, OPT-BST-E, or OSC-CSM line side RX ports.
- Step 40** Remove the loopback fiber from the line RX and TX in the west OPT-BST, OPT-BST-E, or OSC-CSM card.
- Step 41** Return to your originating procedure (NTP).
-

DLP-G311 Verify the East ROADM C-Band Add/Drop Channels

Purpose	This procedure verifies the signal flow through the east side of a ROADM node for C-band add/drop channels.
Tools/Equipment	One of the following: <ul style="list-style-type: none"> • A tunable laser • TXP_MR_10E_C An optical power meter or optical spectrum analyzer 2 bulk attenuators (10 dB) with LC connectors
Prerequisite Procedures	DLP-G46 Log into CTC, page 2-25
Required/As Needed	Required
Onsite/Remote	Onsite
Security Level	Superuser



Note Throughout this task, west refers to Slots 1 through 8, and east refers to Slots 10 through 17.

- Step 1** In node view (single-shelf mode) or multishelf view (multishelf mode), display the Alarms tab.
- Step 2** Create a physical loopback on the east OPT-BST, OPT-BST-E, or OSC-CSM card by connecting the LINE TX port to its LINE RX port. For OPT-BST or OPT-BST-E cards, connect a 10-dB bulk attenuator to the fiber. (OSC-CSM cards do not require attenuation.)



Caution Failure to use proper attenuation might damage equipment.

- Step 3** Wait 2 to 3 minutes, then click the **Alarms** tab. Verify that the LOS alarms on the east OSCM or OSC-CSM card and the OPT-BST or OPT-BST-E card have cleared. The clearing of the LOS alarms indicates that the OSC link is active on the east side.



Note A SDCC Termination Failure alarm will continue to appear due to the OSC signal loopback.

- Step 4** If you are using a tunable laser, follow the manufacturer's instructions to complete the following steps. If you are using a TXP_MR_10E_C card, continue with [Step 5](#).
- Set the output power to a nominal value, such as -3 dBm.
 - Set the tuner to the wavelength you are testing, then continue with [Step 7](#).
- Step 5** If you are using a TXP_MR_10E_C card, complete the “[DLP-G268 Provision TXP_MR_10E_C Cards for Acceptance Testing](#)” task on [page 4-4](#) for the TXP containing the wavelength you will test. Refer to [Table 4-1 on page 4-21](#), if needed.
- Step 6** If you are using a TXP_MR_10E_C card, complete the following steps. If you are using a tunable laser continue with [Step 7](#).
- Display the TXP_MR_10E_C in card view.
 - Click the **Performance > Optics PM > Current Values** tabs.
 - Locate the Port 2 (Trunk) table cell for the TX Optical Pwr parameter. Record the value.

- Step 7** Connect the tunable laser transmitter or the TXP_MR_10E_C card DWDM TX port to the east side fiber patch panel MUX port that is connected to the east 32WSS card CHAN RX port carrying the tested wavelength. (If the TXP_MR_10E_C card was installed during [Chapter 3, “Turn Up a Node,”](#) simply verify the cable connection.)
- Step 8** Connect the TXP_MR_10E_C DWDM RX port or the power meter RX port to the east side fiber patch panel DMX port that is connected with the east 32DMX card CHAN-TX port carrying the tested wavelength. (If the TXP_MR_10E_C card was installed during [Chapter 3, “Turn Up a Node,”](#) simply verify the cable connection.)
- Step 9** Display the 32WSS card in card view.
- Step 10** Click the **Maintenance** tab.
- Step 11** For each wavelength that you will test, click the table cell under Operating Mode and choose **Add Drop** from the drop-down list.
- Step 12** Click **Apply** and then **Yes**, to confirm.
- Step 13** Click the **Provisioning > Optical Chn Optical Connector n > Parameters** tabs, where n = the optical connector number that carries the wavelengths you will test. Refer to [Table 4-1 on page 4-21](#), if needed.
- Step 14** Find the tested wavelength CHAN RX port, then scroll to the right until you see the Power Add parameter. Verify that the Power Add value for the tested port CHAN RX is equal to the output power level of the tunable laser or the TXP_MR_10E_C card measured in [Step 6](#) +/- 1 dBm.
- Step 15** Click the **Provisioning > Optical Line > Parameters** tabs and record the value in the Power table cell for Port 67 (COM-TX) for the wavelength under test.
- Step 16** Verify that the power value from Step 15 reaches the EastSide.Tx.Power.Add&Drop - Output Power set +/- 1 dBm. To view this setpoint:
- In node view (single-shelf mode) or multishelf view (multishelf mode), click the **Provisioning > WDM-ANS > Provisioning** tabs.
 - In the Selector window on the left, expand the **East Side** parameters tree view.
 - Expand the **TX** category.
 - Expand the **Power** category, then highlight **Add&Drop - Output Power**.
 - View the EastSide.TxPower.Add&Drop - Output Power parameter on the right pane.
 - If the power value does not match the value recorded in [Step 15](#), +/- 2dBm, contact your next level of support.
- Step 17** If an MMU card is installed on the east side, complete the following steps. If an MMU card is not installed on the east side, continue with [Step 18](#).
- Display the east 32WSS card in card view.
 - Click the **Provisioning > Optical Line > Parameters** tabs.
 - Record the value in the Power table cell for Port 67 (COM-TX).
 - Display the east MMU card in card view.
 - Click the **Provisioning > Optical Line > Parameters** tabs.
 - Verify that the value in the Power table cell for Port 1(EXP-RX) is equal to the value recorded in [Step c](#), +/- 1.0 dB. If not, use the “NTP-G115 Clean Fiber Connectors” procedure on page 13-25 to clean the fiber connection between the 32WSS and MMU cards. Check the values again. If they still do not match, contact your next level of support.
 - Record the value in the Power table cell for Port 4 (COM-TX).

- h. If a east OPT-BST or OPT-BST-E card is installed, display it in card view and complete Step i. If not, continue with Step j.
- i. Click the Provisioning > Optical Line > Parameters tabs and read the Power value for Port 1 (COM-RX), then continue with Step k.
- j. Display the east OSC-CSM card in card view, click the **Provisioning > Optical Line > Parameters** tabs and read the Power value for Port 2 (COM-RX), then continue with Step k.
- k. Verify that the value in Step i or j matches the power recorded in Step g, +/- 1.5 dB. If not, use the [“NTP-G115 Clean Fiber Connectors” procedure on page 13-25](#) to clean the fiber connection between the OPT-BST, OPT-BST-E, or OSC-CSM and MMU cards. Check the values again. If they still do not match, contact your next level of support.
- l. Continue with [Step 19](#).

Step 18 Verify the connection between the 32WSS and OPT-BST, OPT-BST-E or OSC_CSM cards:

- a. Display the east 32WSS card in card view.
- b. Click the **Provisioning > Optical Line > Parameters** tabs.
- c. Record the value in the Power table cell for Port 67 (COM-TX).
- d. If a OPT-BST or OPT-BST-E card is installed on the east side, display it in card view and complete Step e. If not, continue with Step f.
- e. Click the **Provisioning > Optical Line > Parameters** tabs and read the Power value for Port 1 (COM-RX), then continue with Step g.
- f. Display the east OSC-CSM card in card view, click the **Provisioning > Optical Line > Parameters** tabs and read the Power value for Port 2 (COM-RX), then continue with Step g.
- g. Verify that the value in Step e or f matches the power recorded in Step c, +/- 1.0 dB. If so, continue with [Step 19](#). If not, use the [“NTP-G115 Clean Fiber Connectors” procedure on page 13-25](#) to clean the fiber connection between the OPT-BST, OPT-BST-E, or OSC-CSM and 32WSS cards. Check the values again. If they still do not match, contact your next level of support.

Step 19 If an OPT-PRE card is installed on the east side, complete the following steps. If not, continue with [Step 20](#).

- a. Display the east OPT-PRE in card view.
- b. Click the **Provisioning > Optical Line > Parameters** tabs.
- c. Locate the Power parameter for Port 1 (COM-RX). Record the value.
- d. Display the east OPT-BST, OPT-BST-E, or OSC-CSM card in card view.
- e. Click the **Provisioning > Optical Line > Parameters** tabs.
- f. Locate the Port 2 (COM-TX) Power value (for OPT-BST or OPT-BST-E cards) or Port 3 (COM-TX) Power value (for OSC-CSM card). Verify that the value matches the power recorded in Step c, +/- 1.5 dB. If not, use the [“NTP-G115 Clean Fiber Connectors” procedure on page 13-25](#) to clean the fiber connection between the OPT-PRE card and the OPT-BST, OPT-BST-E, or OSC-CSM card. Check the values again. If they still do not match, contact your next level of support.
- g. For the east OPT-PRE card, complete the [“DLP-G80 Verify the OPT-PRE Amplifier Laser and Power” task on page 4-6](#).

Step 20 If an MMU card is installed on the east side, complete the following steps. If an MMU card is not installed on the east side, continue with [Step 21](#).

- a. Display the east MMU card in card view.
- b. Click the **Provisioning > Optical Line > Parameters** tabs.

- c. Locate the Port 68 (COM-RX) Power parameter. Record the value.
- d. If an OPT-PRE card is installed on the east side, display it in card view and complete Step e. If not, continue with Step f.
- e. Click the OPT-PRE **Provisioning > Opt.Ampli.Line > Parameters** tabs. Record the Total Output Power value for Port 2 (COM-TX), then continue with Step i.
- f. If an east OPT-BST or OPT-BST-E card is installed, display it in card view and complete Step g. If not, continue with Step h.
- g. Click the Provisioning > Optical Line > Parameters tabs and read the Power value for Port 2 (COM-TX), then continue with Step i.
- h. Display the east OSC-CSM card in card view, click the Provisioning > Optical Line > Parameters tabs and read the Power value for Port 3 (COM-TX), then continue with Step i.
- i. Verify that value in the Step e, g, or h matches the power recorded in Step e, +/- 1.0 dB. If not, use the “[NTP-G115 Clean Fiber Connectors](#)” procedure on page 13-25 to clean the fiber connection between the MMU card and the OPT-BST, OPT-BST-E, or OSC-CSM cards. Check the values again. If they still do not match, contact your next level of support.
- j. Display the east MMU card in card view.
- k. Click the **Provisioning > Optical Line > Parameters** tabs.
 - l. Record the value in the Power table cell for Port 2 (EXP-TX).
- m. Display the east 32WSS card in card view.
- n. Click the **Provisioning > Optical Line > Parameters** tabs.
- o. Verify that the value in the Power table cell for Port 68 (COM-RX) is equal to the value recorded in Step l, +/- 1.0 dB. If not, use the “[NTP-G115 Clean Fiber Connectors](#)” procedure on page 13-25 to clean the fiber connection between the 32WSS and MMU cards. Check the values again. If they still do not match, contact your next level of support.
- p. Continue with [Step 22](#).

Step 21 Verify the connection between the east 32WSS card and the OPT-BST, OPT-BST-E, OPT-PRE, or OSC-CSM card:

- a. Display the east 32WSS in card view.
- b. Click the **Provisioning > Optical Line > Parameters** tabs.
- c. Locate the Port 68 (COM-RX) Power parameter. Record the value.
- d. If an east OPT-PRE card is installed, display it in card view and complete Step e. If not, continue with Step f.
- e. Click the **Provisioning > Opt.Ampli.Line > Parameters** tabs and read the Total Output Power value for Port 2 (COM-TX), then continue with Step i.
- f. If an east OPT-BST or OPT-BST-E card is installed, display it in card view and complete Step g. If not, continue with Step h.
- g. Click the **Provisioning > Optical Line > Parameters** tabs and read the Power value for Port 2 (COM-TX), then continue with Step i.
- h. Display the east OSC-CSM card in card view. Click the **Provisioning > Optical Line > Parameters** tabs and read the Power value for Port 3 (COM-TX), then continue with Step i.
- i. Verify that the value in Step e, g, or h matches the power recorded in Step c, +/- 1.5 dB. If not, use the “[NTP-G115 Clean Fiber Connectors](#)” procedure on page 13-25 to clean the fiber connection between the 32WSS card and the OPT-PRE, OPT-BST, or OSC-CSM card.

- Step 22** Verify the east 32WSS and 32DMX connection:
- Display the east 32WSS card in card view.
 - Click the **Provisioning > Optical Line > Parameters** tabs, and record the value in the Power table cell for Port 69 (DROP-TX).
 - Display the east 32DMX card in card view.
 - Click the **Provisioning > Optical Line > Parameters** tabs. Record the value in the Port 33 (COM-RX) table cell. Verify that the value is equal to the value recorded in **b.**, +/- 1 dBm. If not, use the [“NTP-G115 Clean Fiber Connectors” procedure on page 13-25](#) to clean the fiber connection between the 32WSS and 32DMX cards. Check the values again. If they still do not match, contact your next level of support.
- Step 23** Display the east 32DMX card in card view.
- Step 24** Click the **Provisioning > Optical Chn > Parameters** tab. Record the CHAN-TX port value under the Power parameter for the wavelength under test.
- Step 25** Verify that the power value from [Step 24](#) reaches the EastSide.Rx.Power.Add&Drop - Drop Power setpoint +/- 2 dBm. To view this setpoint:
- Go to node view (single-shelf mode) or multishelf view (multishelf mode) and click the **Provisioning > WDM-ANS > Provisioning** tabs.
 - In the Selector window on the left, expand the **East Side** parameters tree view.
 - Expand the **RX** category.
 - Expand the **Power** category, then highlight **Add&Drop - Drop Power**.
 - View the EastSide.Rx.Power.Add&Drop - Drop Power parameter on the right pane.
 - If the power value does not match the value recorded in [Step 24](#) (+/- 2 dBm), contact your next level of support.
- Step 26** If you are using a TXP_MR_10E_C card, display it in card view. If not, read the values called for in [Step 28](#) on the optical test set or tunable laser you are using.
- Step 27** Click the **Performance > Optics PM > Current Values** tabs.
- Step 28** In the Port 2 (Trunk) column, locate the RX Optical Power value. Verify that the value matches the power in [Step 24](#), +/- 2 dBm. If the power values do not match (+/- 2 dBm), complete the following steps:
- Remove, clean, and replace the cable connecting the TXP_MR_10E_C RX port to the east fiber patch panel DMX port for the tested wavelength. See the [“NTP-G115 Clean Fiber Connectors” procedure on page 13-25](#).
 - Repeat this step. If the power values still do not match (+/- 2 dBm) contact your next level of support.
- Step 29** Repeat Steps [4](#) through [28](#) for the remaining wavelengths.
- Step 30** Display the east 32WSS card in card view.
- Step 31** Click the **Maintenance** tab.
- Step 32** Click the table cell under Operating Mode and choose **Not Assigned** from the drop-down list for all wavelengths.
- Step 33** Click **Apply**, then click **Yes** to confirm.
- Step 34** Disconnect the TXP or tunable laser from the east side patch panel.
- Step 35** Unplug the physical loopback fiber from the line TX and RX in the OPT-BST, OPT-BST-E, or OSC-CSM card.

Step 36 Return to your originating procedure (NTP).

DLP-G312 Verify the West ROADM C-Band Add/Drop Channels

Purpose	This procedure verifies the signal flow through the west side of an ROADM node for C-band add/drop channels.
Tools/Equipment	One of the following: <ul style="list-style-type: none"> • A tunable laser • TXP_MR_10E_C An optical power meter or optical spectrum analyzer 2 bulk attenuators (10 dB) with LC connectors
Prerequisite Procedures	“DLP-G46 Log into CTC” task on page 2-25
Required/As Needed	Required
Onsite/Remote	Onsite
Security Level	Superuser



Note Throughout this task, west refers to Slots 1 through 8, and east refers to Slots 10 through 17.

Step 1 In node view (single-shelf mode) or multishelf view (multishelf mode), display the Alarms tab.

Step 2 Create a physical loopback on the west OPT-BST, OPT-BST-E, or OSC-CSM card by connecting the LINE TX port to its LINE RX port. For OPT-BST or OPT-BST-E cards, connect a 10-dB bulk attenuator to the fiber. (OSC-CSM cards do not require attenuation.)



Caution Failure to use proper attenuation might damage equipment.

Step 3 Wait 2 to 3 minutes, then click the **Alarms** tab. Verify that the LOS alarms on the west OSCM or OSC-CSM card and the OPT-BST or OPT-BST-E card have cleared. The clearing of the LOS alarms indicates that the OSC link is active on the west side.



Note A SDCC Termination Failure alarm will continue to appear due to the OSC signal loopback.

Step 4 If you are using a tunable laser, follow the manufacturer’s instructions to complete the following steps. If you are using a TXP_MR_10E_C card, continue with [Step 5](#).

- a. Set the output power to a nominal value, such as -3 dBm.
- b. Set the tuner to the wavelength you are testing, then continue with [Step 7](#).

Step 5 If you are using a TXP_MR_10E_C card, complete the [“DLP-G268 Provision TXP_MR_10E_C Cards for Acceptance Testing” task on page 4-4](#) for the TXP containing the wavelength you will test. Refer to [Table 4-1 on page 4-21](#), if needed.

- Step 6** If you are using a TXP_MR_10E_C card, complete the following steps. If you are using a tunable laser continue with [Step 7](#).
- Display the TXP_MR_10E_C in card view.
 - Click the **Performance > Optics PM > Current Values** tabs.
 - Locate the Port 2 (Trunk) table cell for the TX Optical Pwr parameter. Record the value.
- Step 7** Connect the tunable laser transmitter or the TXP_MR_10E_C card DWDM TX port to the west side fiber patch panel MUX port that is connected to the west 32WSS card CHAN RX port carrying the tested wavelength. (If the TXP_MR_10E_C card was installed during [Chapter 3, “Turn Up a Node,”](#) simply verify the cable connection.)
- Step 8** Connect the TXP_MR_10E_C DWDM RX port or the power meter RX port to the west side fiber patch panel DMX port that is connected with the west 32DMX card CHAN-TX port carrying the tested wavelength. (If the TXP_MR_10E_C card was installed during [Chapter 3, “Turn Up a Node,”](#) simply verify the cable connection.)
- Step 9** Display the 32WSS card in card view.
- Step 10** Click the **Maintenance** tab.
- Step 11** For each wavelength that you will test, click the table cell under Operating Mode and choose **Add Drop** from the drop-down list.
- Step 12** Click **Apply** and then **Yes**, to confirm.
- Step 13** Click the **Provisioning > Optical Chn Optical Connector_n > Parameters** tabs, where *n* = the optical connector number that carries the wavelengths you will test. Refer to [Table 4-1 on page 4-21](#), if needed.
- Step 14** Find the tested wavelength CHAN RX port, then scroll to the right until you see the Power Add parameter. Verify that the Power Add value for the tested port CHAN RX is equal to the output power level of the tunable laser or the TXP_MR_10E_C card measured in [Step 6](#) +/- 1 dBm.
- Step 15** Click the **Provisioning > Optical Line > Parameters** tabs and record the value in the Power table cell for Port 67 (COM-TX) for the wavelength under test.
- Step 16** Verify that the power value from Step 15 reaches the WestSide.Tx.Power.Add&Drop - Output Power set +/- 1 dBm. To view this setpoint:
- In node view (single-shelf mode) or multishelf view (multishelf mode), click the **Provisioning > WDM-ANS > Provisioning** tabs.
 - In the Selector window on the left, expand the **West Side** parameters tree view.
 - Expand the **TX** category.
 - Expand the **Power** category, then highlight **Add&Drop - Output Power**.
 - View the WestSide.TxPower.Add&Drop - Output Power parameter on the right pane.
 - If the power value does not match the value recorded in [Step 15](#), +/- 2dBm, contact your next level of support.
- Step 17** If an MMU card is installed on the west side, complete the following steps. If an MMU card is not installed on the west side, continue with [Step 18](#).
- Display the west 32WSS card in card view.
 - Click the **Provisioning > Optical Line > Parameters** tabs.
 - Record the value in the Power table cell for Port 67 (COM-TX).
 - Display the west MMU card in card view.
 - Click the **Provisioning > Optical Line > Parameters** tabs.

- f. Verify that the value in the Power table cell for Port 1 (EXP-RX) is equal to the value recorded in Step c, +/- 1.0 dB. If not, use the “NTP-G115 Clean Fiber Connectors” procedure on page 13-25 to clean the fiber connection between the 32WSS and MMU cards. Check the values again. If they still do not match, contact your next level of support.
- g. Record the value in the Power table cell for Port 4 (COM-TX).
- h. If a west OPT-BST or OPT-BST-E card is installed, display it in card view and complete Step i. If not, continue with Step j.
- i. Click the Provisioning > Optical Line > Parameters tabs and read the Power value for Port 1 (COM-RX), then continue with Step k.
- j. Display the west OSC-CSM card in card view, click the **Provisioning > Optical Line > Parameters** tabs and read the Power value for Port 2 (COM-RX), then continue with Step k.
- k. Verify that the value in Step i or j matches the power recorded in Step g, +/- 1.5 dB. If not, use the “NTP-G115 Clean Fiber Connectors” procedure on page 13-25 to clean the fiber connection between the OPT-BST, OPT-BST-E, or OSC-CSM and MMU cards. Check the values again. If they still do not match, contact your next level of support.
- l. Continue with Step 19.

Step 18 Verify the connection between the 32WSS and OPT-BST, OPT-BST-E or OSC_CSM cards:

- a. Display the west 32WSS card in card view.
- b. Click the **Provisioning > Optical Line > Parameters** tabs.
- c. Record the value in the Power table cell for Port 67 (COM-TX).
- d. If a OPT-BST or OPT-BST-E card is installed on the west side, display it in card view and complete Step e. If not, continue with Step f.
- e. Click the **Provisioning > Optical Line > Parameters** tabs and read the Power value for Port 1 (COM-RX), then continue with Step g.
- f. Display the west OSC-CSM card in card view, click the **Provisioning > Optical Line > Parameters** tabs and read the Power value for Port 2 (COM-RX), then continue with Step g.
- g. Verify that the value in Step e or f matches the power recorded in Step c, +/- 1.0 dB. If so, continue with Step 19. If not, use the “NTP-G115 Clean Fiber Connectors” procedure on page 13-25 to clean the fiber connection between the OPT-BST, OPT-BST-E, or OSC-CSM and 32WSS cards. Check the values again. If they still do not match, contact your next level of support.

Step 19 If an OPT-PRE card is installed on the west side, complete the following steps. If not, continue with Step 20.

- a. Display the west OPT-PRE in card view.
- b. Click the **Provisioning > Optical Line > Parameters** tabs.
- c. Locate the Power parameter for Port 1 (COM-RX). Record the value.
- d. Display the west OPT-BST, OPT-BST-E, or OSC-CSM card in card view.
- e. Click the **Provisioning > Optical Line > Parameters** tabs.
- f. Locate the Port 2 (COM-TX) Power value (for OPT-BST or OPT-BST-E cards) or Port 3 (COM-TX) Power value (for OSC-CSM card). Verify that the value matches the power recorded in Step c, +/- 1.5 dB. If not, use the “NTP-G115 Clean Fiber Connectors” procedure on page 13-25 to clean the fiber connection between the OPT-PRE card and the OPT-BST, OPT-BST-E, or OSC-CSM card. Check the values again. If they still do not match, contact your next level of support.
- g. For the west OPT-PRE card, complete the “DLP-G80 Verify the OPT-PRE Amplifier Laser and Power” task on page 4-6.

- Step 20** If an MMU card is installed on the west side, complete the following steps. If an MMU card is not installed on the west side, continue with [Step 21](#).
- a. Display the west MMU card in card view.
 - b. Click the **Provisioning > Optical Line > Parameters** tabs.
 - c. Locate the Port 68 (COM-RX) Power parameter. Record the value.
 - d. If an OPT-PRE card is installed on the west side, display it in card view and complete Step e. If not, continue with Step f.
 - e. Click the OPT-PRE **Provisioning > Opt.Ampli.Line > Parameters** tabs. Record the Total Output Power value for Port 2 (COM-TX), then continue with Step i.
 - f. If an west OPT-BST or OPT-BST-E card is installed, display it in card view and complete Step g. If not, continue with Step h.
 - g. Click the Provisioning > Optical Line > Parameters tabs and read the Power value for Port 2 (COM-TX), then continue with Step i.
 - h. Display the west OSC-CSM card in card view, click the Provisioning > Optical Line > Parameters tabs and read the Power value for Port 3 (COM-TX), then continue with Step i.
 - i. Verify that value in the Step e, g, or h matches the power recorded in Step e, +/- 1.0 dB. If not, use the “[NTP-G115 Clean Fiber Connectors](#)” procedure on page 13-25 to clean the fiber connection between the MMU card and the OPT-BST, OPT-BST-E, or OSC-CSM cards. Check the values again. If they still do not match, contact your next level of support.
 - j. Display the west MMU card in card view.
 - k. Click the **Provisioning > Optical Line > Parameters** tabs.
 - l. Record the value in the Power table cell for Port 2 (EXP-TX).
 - m. Display the west 32WSS card in card view.
 - n. Click the **Provisioning > Optical Line > Parameters** tabs.
 - o. Verify that the value in the Power table cell for Port 68 (COM-RX) is equal to the value recorded in Step l, +/- 1.0 dB. If not, use the “[NTP-G115 Clean Fiber Connectors](#)” procedure on page 13-25 to clean the fiber connection between the 32WSS and MMU cards. Check the values again. If they still do not match, contact your next level of support.
 - p. Continue with [Step 22](#).
- Step 21** Verify the connection between the west 32WSS card and the OPT-BST, OPT-BST-E, OPT-PRE, or OSC-CSM card:
- a. Display the west 32WSS in card view.
 - b. Click the **Provisioning > Optical Line > Parameters** tabs.
 - c. Locate the Port 68 (COM-RX) Power parameter. Record the value.
 - d. If a west OPT-PRE card is installed, display it in card view and complete Step e. If not, continue with Step f.
 - e. Click the **Provisioning > Opt.Ampli.Line > Parameters** tabs and read the Total Output Power value for Port 2 (COM-TX), then continue with Step i.
 - f. If an west OPT-BST or OPT-BST-E card is installed, display it in card view and complete Step g. If not, continue with Step h.
 - g. Click the **Provisioning > Optical Line > Parameters** tabs and read the Power value for Port 2 (COM-TX), then continue with Step i.

- h. Display the west OSC-CSM card in card view. Click the **Provisioning > Optical Line > Parameters** tabs and read the Power value for Port 3 (COM-TX), then continue with Step i.
 - i. Verify that the value in Step e, g, or h matches the power recorded in Step c, +/- 1.5 dB. If not, use the “[NTP-G115 Clean Fiber Connectors](#)” procedure on page 13-25 to clean the fiber connection between the 32WSS card and the OPT-PRE, OPT-BST, or OSC-CSM card.
- Step 22** Verify the west 32WSS and 32DMX connection:
 - a. Display the west 32WSS card in card view.
 - b. Click the **Provisioning > Optical Line > Parameters** tabs, and record the value in the Power table cell for Port 69 (DROP-TX).
 - c. Display the west 32DMX card in card view.
 - d. Click the **Provisioning > Optical Line > Parameters** tabs. Record the value in the Port 2 (COM-RX) table cell. Verify that the value is equal to the value recorded in b, +/- 1 dBm. If not, use the “[NTP-G115 Clean Fiber Connectors](#)” procedure on page 13-25 to clean the fiber connection between the 32WSS and 32DMX cards. Check the values again. If they still do not match, contact your next level of support.
- Step 23** Display the west 32DMX card in card view.
- Step 24** Click the **Provisioning > Optical Chn > Parameters** tab. Record the CHAN-TX port value under the Power parameter for the wavelength under test.
- Step 25** Verify that the power value from Step 24 reaches the WestSide.Rx.Power.Add&Drop - Drop Power setpoint +/- 2 dBm. To view this setpoint:
 - a. Go to node view (single-shelf mode) or multishelf view (multishelf mode) and click the **Provisioning > WDM-ANS > Provisioning** tabs.
 - b. In the Selector window on the left, expand the **West Side** parameters tree view.
 - c. Expand the **RX** category.
 - d. Expand the **Power** category, then highlight **Add&Drop - Drop Power**.
 - e. View the WestSide.Rx.Power.Add&Drop - Drop Power parameter on the right pane.
 - f. If the power value does not match the value recorded in Step 24 (+/- 2 dBm), contact your next level of support.
- Step 26** Display the TXP_MR_10E_C card in card view.
- Step 27** Click the **Performance > Optics PM > Current Values** tabs.
- Step 28** In the Port 2 (Trunk) column, locate the RX Optical Power value. Verify that the value matches the power in Step 24, +/- 2 dBm. If the power values do not match (+/- 2 dBm), complete the following steps:
 - a. Remove, clean, and replace the cable connecting the TXP_MR_10E_C RX port to the west fiber patch panel DMX port for the tested wavelength. See the “[NTP-G115 Clean Fiber Connectors](#)” procedure on page 13-25.
 - b. Repeat this step. If the power values still do not match (+/- 2 dBm) contact your next level of support.
- Step 29** Repeat Steps 4 through 28 for the remaining wavelengths.
- Step 30** Display the west 32WSS card in card view.
- Step 31** Click the **Maintenance** tab.
- Step 32** Click the table cell under Operating Mode and choose **Not Assigned** from the drop-down list for all wavelengths.
- Step 33** Click **Apply**, then click **Yes** to confirm.

- Step 34** Disconnect the TXP or tunable laser from the west side patch panel.
- Step 35** Unplug the physical loopback fiber from the line TX and RX in the OPT-BST, OPT-BST-E, or OSC-CSM card.
- Step 36** Return to your originating procedure.

NTP-G154 Perform the ROADM Node with 32WSS-L and 32DMX-L Cards Acceptance Test

Purpose	This acceptance test verifies that a ROADM node provisioned for L-band wavelengths is operating properly before you connect it to the network. The test verifies that each add/drop and pass-through port on the 32WSS-L and 32DMX-L card operates properly and verifies the operation of the amplifiers. The test also checks the power levels at each transmit and receive port to ensure that power loss in the cabling is within tolerance. If MMU cards are installed, the test verifies that the MMU insertion loss doesn't impact add, drop, or pass through traffic.
Tools/Equipment	One of the following: <ul style="list-style-type: none"> • A tunable laser • TXP_MR_10E_L An optical power meter or optical spectrum analyzer 2 bulk attenuators (10 dB) with LC connectors
Prerequisite Procedures	Chapter 3, “Turn Up a Node”
Required/As Needed	Required
Onsite/Remote	Onsite
Security Level	Superuser



Note

Optical power measurements require either a tunable laser or a multirate transponder to generate the proper optical wavelength. If multirate transponders were installed during completion of [Chapter 3, “Turn Up a Node,”](#) they can be used for this procedure. No additional cabling changes are needed.



Note

Because the node is isolated and no line-side fibers are connected during the test, the power levels going into the line-side components will not be the same as they would be in a real network setup. Therefore, if the ROADM shelf does not contain OPT-BST-L and OPT-AMP-L (provisioned in OPT-PRE mode) amplifiers on both the east and west sides, you must lower the OPT-AMP-L power thresholds so that it turns on properly. At the end of the test, you will run ANS to configure the node with the correct parameters for the network acceptance test.

- Step 1** Make a copy of [Table 4-2 on page 4-43](#) and place it in a convenient location for reference throughout this procedure. The table shows the 32WSS-L ports and the wavelengths assigned to them. The 32 wavelengths are divided among four physical multi-fiber push on (MPO) connectors on the 32WSS-L card. Each MPO connector is assigned eight wavelengths. In CTC, the MPO connector appears in the

card view Provisioning > Optical Connector tab. Each Optical Connector subtab represents an MPO connector. Ports 1 through 32 are the channel RX (add) ports; Ports 33 through 64 are the Pass-Through ports.

Table 4-2 32WSS-L Ports and Wavelengths Test Checklist

32WSS-L Provisioning Subtab	Port #	Wavelength	Tested: Pass-Through	Tested: Add/Drop West	Tested: Add/Drop East
Optical Chn: Optical Connector 1	RX 1, PT 33	1577.86			
	RX 2, PT 34	1578.69			
	RX 3, PT 35	1579.52			
	RX 4, PT 36	1580.35			
	RX 5, PT 37	1581.18			
	RX 6, PT 38	1582.02			
	RX 7, PT 39	1582.85			
	RX 8, PT 40	1583.69			
Optical Chn: Optical Connector 2	RX 9, PT 41	1584.53			
	RX 10, PT 42	1585.36			
	RX 11, PT 43	1586.20			
	RX 12, PT 44	1587.04			
	RX 13, PT 45	1587.88			
	RX 14, PT 46	1588.73			
	RX 15, PT 47	1589.57			
	RX 16, PT 48	1590.41			
Optical Chn: Optical Connector 3	RX 17, PT 49	1591.26			
	RX 18, PT 50	1592.10			
	RX 19, PT 51	1592.95			
	RX 20, PT 52	1593.79			
	RX 21, PT 53	1594.64			
	RX 22, PT 54	1595.49			
	RX 23, PT 55	1596.34			
	RX 24, PT 56	1597.19			
Optical Chn: Optical Connector 4	RX 25, PT 57	1598.04			
	RX 26, PT 58	1598.89			
	RX 27, PT 59	1599.75			
	RX 28, PT 60	1600.60			
	RX 29, PT 61	1601.46			
	RX 30, PT 62	1602.31			
	RX 31, PT 63	1603.17			
	RX 32, PT 64	1604.03			

- Step 2** Complete the “[DLP-G46 Log into CTC](#)” task on page 2-25 at the ROADM node that you want to test. If you are already logged in, continue with [Step 3](#).
- Step 3** Display the ROADM node in node view (single-shelf mode) or multishelf view (multishelf mode).
- Step 4** Click the **Alarms** tab.
- Verify that the alarm filter is not on. See the “[DLP-G128 Disable Alarm Filtering](#)” task on page 8-28 as necessary.
 - Verify that no equipment alarms appear indicating equipment failure or other hardware problems. (Equipment alarms are indicated by an EQPT in the Alarms tab Cond column.) If equipment failure alarms appear, investigate and resolve them before continuing. Refer to the *Cisco ONS 15454 DWDM Troubleshooting Guide* for procedures.



Note The OSC terminations created during node turn-up will generate two alarms for each side of the shelf, one for an LOS on the OPT-BST-L card, and the other for an LOS on the OSC-CSM or OSCM card. If OSCM cards are installed, SDCC termination failure (EOC) alarms will appear.

- Step 5** In node view (single-shelf mode) or multishelf view (multishelf mode), click the **Provisioning > WDM-ANS > Port Status** tabs. Verify that all statuses under Link Status are listed as Success - Changed, Success - Unchanged, or Not Applicable. If any are not, complete the following steps:
- Delete the two OSC channels using the “[DLP-G186 Delete an OSC Termination](#)” task on page 10-44.
 - Complete the “[NTP-G37 Run Automatic Node Setup](#)” procedure on page 3-82.
 - Create the OSC channels using the “[NTP-G38 Provision OSC Terminations](#)” procedure on page 3-83.
- Step 6** If MMU cards are installed, complete the following steps. If not, continue with [Step 7](#).
- Display the east MMU card in card view.
 - Click the **Provisioning > Optical Line > Parameters** tabs.
 - Click the **Admin State** table cell for the COM RX, COM TX, EXP RX, and EXP TX ports and choose **OOS,MT** (ANSI) or **Locked,maintenance** (ETSI) from the drop-down list.
 - Click **Apply**, then click **Yes** to confirm.
 - Display the west MMU card in card view.
 - Click the **Provisioning > Optical Line > Parameters** tabs.
 - Click the **Admin State** table cell for the COM RX, COM TX, EXP RX, and EXP TX ports and choose **OOS,MT** (ANSI) or **Locked,maintenance** (ETSI) from the drop-down list.
- Step 7** Display the east 32WSS-L in card view.
- Step 8** Click the **Provisioning > Optical Chn Optical Connector_n > Parameters** tabs, where *n* = the optical connector number that carries the wavelengths you will test. Refer to [Table 4-2 on page 4-43](#), if needed.
- Step 9** Click the **Admin State** table cell for the add port carrying the tested wavelength, then choose **OOS,MT** (ANSI) or **Locked,maintenance** (ETSI) from the drop-down list. For example, if the tested wavelength is 1530.33 nm (shown as 1530.3), you would click the Port 1 (CHAN-RX) Admin State field and choose OOS,MT or Locked,maintenance from the drop-down list.
- Step 10** Change the administrative state of the pass-through port corresponding to the port in [Step 9](#) to **OOS,MT** (ANSI) or **Locked,maintenance** (ETSI). For example, if the tested wavelength is 1577.86 nm (shown as 1577.8), you would click the Port 33 (PASS-THROUGH) Admin State field and choose OOS,MT or Locked,maintenance from the drop-down list. Refer to [Table 4-2 on page 4-43](#), if needed.

- Step 11** Click **Apply**, then click **Yes** to confirm.
- Step 12** Repeat Steps 8 through 11 for all wavelengths that you will test.
- Step 13** Display the west 32WSS-L in card view.
- Step 14** Repeat Steps 8 through 12 for the west 32WSS-L card.
- Step 15** Display the east 32DMX-L in card view and complete the following steps:
- Choose the **Provisioning > Optical Line > Parameters** tabs.
 - For Port 33 (COM-RX), click the **Admin State** table cell and choose **OOS,MT (ANSI)** or **Locked,maintenance (ETSI)** from the drop-down list.
 - Click **Apply**, then click **Yes** to confirm.
- Step 16** Repeat Step 15 for the west 32DMX-L card.
- Step 17** Complete the “[DLP-G362 Verify ROADM Node L-Band Pass-Through Channels](#)” task on page 4-46.
- Step 18** Complete the following tasks for channels that will be added or dropped on the node.
- [DLP-G363 Verify the East ROADM L-Band Add/Drop Channels, page 4-54](#)
 - [DLP-G364 Verify the West ROADM L-Band Add/Drop Channels, page 4-59](#)
- Step 19** If MMU cards are installed, complete the following steps. If not, continue with Step 20.
- Display the east MMU card in card view.
 - Click the **Provisioning > Optical Line > Parameters** tabs.
 - Click the **Admin State** table cell for the COM RX, COM TX, EXP RX, and EXP TX ports and choose **IS,AINS (ANSI)** or **Unlocked,automaticInService (ETSI)** from the drop-down list.
 - Click **Apply**, then click **Yes** to confirm.
 - Display the west MMU card in card view.
 - Click the **Provisioning > Optical Line > Parameters** tabs.
 - Click the **Admin State** table cell for the COM RX, COM TX, EXP RX, and EXP TX ports and choose **IS,AINS (ANSI)** or **Unlocked,automaticInService (ETSI)** from the drop-down list.
- Step 20** Display the east 32WSS-L in card view.
- Step 21** Click the **Provisioning > Optical Chn Optical Connector n > Parameters** tabs, where n = the optical connector number that carries the wavelengths you tested.
- Step 22** Click the **Admin State** table cell then choose **IS,AINS (ANSI)** or **Unlocked,automaticInService (ETSI)** from the drop-down list for all ports that were changed to OOS,MT or Locked,Maintenance.
- Step 23** Click **Apply**.
- Step 24** Repeat Steps 21 through 23 for all the ports that are **OOS,MT** or **Locked,maintenance** on the east 32WSS-L card.
- Step 25** Display the west 32WSS-L in card view.
- Step 26** Repeat Steps 21 through 24 for all ports on the west 32WSS-L card.
- Step 27** Display the east 32DMX-L in card view.
- Step 28** Choose the **Provisioning > Optical Line > Parameters** tabs.
- Step 29** For Port 33, click the **Admin State** table cell and choose **IS,AINS (ANSI)** or **Unlocked,automaticInService (ETSI)** from the drop-down list.
- Step 30** Click **Apply**.
- Step 31** Display the west 32DMX-L card in card view.

- Step 32** Repeat Steps 28 through 30 for the west 32DMX-L card.
- Step 33** Delete both OSC channels using the “[DLP-G186 Delete an OSC Termination](#)” task on page 10-44.
- Step 34** Complete the “[NTP-G37 Run Automatic Node Setup](#)” procedure on page 3-82.
- Step 35** Create the two OSC channels using the “[NTP-G38 Provision OSC Terminations](#)” procedure on page 3-83.
- Step 36** Click the **Alarms** tab.
- a. Verify that the alarm filter is not on. See the “[DLP-G128 Disable Alarm Filtering](#)” task on page 8-28 as necessary.
 - b. Verify that no equipment failure alarms appear on the node. If alarms appear, investigate and resolve them before continuing. Refer to the *Cisco ONS 15454 DWDM Troubleshooting Guide* for procedures.

Stop. You have completed this procedure.

DLP-G362 Verify ROADM Node L-Band Pass-Through Channels

Purpose

This task verifies the signal flow through a ROADM node for L-band pass-through channels. Configuring a channel pass-through mode means that the channel passes through both 32WSS-L cards. The channel passes through the first 32WSS-L from the COM RX port to the EXP TX port. In the second 32WSS-L, the channel goes from the EXP RX port to the COM TX port. The channel is not terminated inside the node. If MMU cards are installed, the channel passes through the MMU COM RX and EXP TX ports to the 32WSS-L COM RX and EXP TX ports on one side. On the other side, the channel goes from the 32WSS-L EXP RX and 32WSS-L COM TX ports to the MMU EXP RX and COM TX.

Tools/Equipment

One of the following:

- A tunable laser
- TXP_MR_10E_L

An optical power meter or optical spectrum analyzer

2 bulk attenuators (10 dB) with LC connectors

Prerequisite Procedures “[DLP-G46 Log into CTC](#)” task on page 2-25

Required/As Needed Required

Onsite/Remote Onsite

Security Level Superuser



Note

Throughout this task, west refers to Slots 1 through 8, and east refers to Slots 10 through 17.

- Step 1** Create a physical loopback on the west OPT-BST-L or OSC-CSM card by connecting the LINE TX port to its LINE RX port. For OPT-BST-L cards, connect a 10-dB bulk attenuator to the fiber. (OSC-CSM cards do not require attenuation.)

**Caution**

Failure to use proper attenuation might damage equipment.

- Step 2** If an OPT-AMP-L (provisioned in OPT-PRE mode) amplifier is installed on the west side (where the physical loopback was created), perform the following steps. If not, continue with [Step 3](#).
- Display the OPT-AMP-L card in card view, then click the **Provisioning > Optical Line > Optics Thresholds** tabs.
 - Under Types, click **Alarm**, then click **Refresh**. The alarm thresholds for the OPT-AMP-L will appear.
 - Double-click the Power Failure Low table cell for Port 1 (1-Line-2-1 RX) and delete the current value.
 - Type a new value of **-30**. Press **Enter** on your computer,
 - On the CTC window, click **Apply**, then click **Yes** on the confirmation dialog box.
- Step 3** If an OPT-AMP-L (provisioned in OPT-PRE mode) amplifier is installed on the east side (where the physical loopback was created), perform the following steps. If not, continue with [Step 4](#).
- Display the OPT-AMP-L card in card view, then click the **Provisioning > Optical Line > Optics Thresholds** tabs.
 - Under Types, click **Alarm**, then click **Refresh**. The alarm thresholds for the OPT-AMP-L will appear.
 - Double-click the Power Failure Low table cell for Port 1 (1-Line-2-1 RX) and delete the current value.
 - Type a new value of **-30**. Press **Enter** on your computer,
 - On the CTC window, click **Apply**, then click **Yes** on the confirmation dialog box.
- Step 4** Wait 2 to 3 minutes, then in node view (single-shelf mode) or multishelf view (multishelf mode) click the **Alarms** tab. Verify that the LOS alarms on the west OSCM or OSC-CSM card and the OPT-BST-L card have cleared. The clearing of the LOS alarms indicates that the OSC link is active on the west side. If the alarms do not clear, contact your next level of support.

**Note**

A SDCC Termination Failure alarm will continue to appear due to the OSC signal loopback.

- Step 5** Display the west 32WSS-L card in card view.
- Step 6** Click the **Maintenance** tab.
- Step 7** Click the Operating Mode table cell and choose **Pass Through** from the drop-down list.
- Step 8** Click **Apply**, then click **Yes** to confirm.
- Step 9** Display the east 32WSS-L card in card view.
- Step 10** Repeat Steps [6](#) through [8](#) for the east 32WSS-L card.
- Step 11** If you are using a tunable laser, follow the manufacturer's instructions to complete the following steps. If you are using a TXP_MR_10E_L card, continue with [Step 12](#).
- Set the output power to a nominal value, such as **-3 dBm**.
 - Set the tuner to the wavelength you will test, then continue with [Step 13](#).
- Step 12** If you are using a TXP_MR_10E_L card, complete the “[DLP-G358 Provision TXP_MR_10E_L Card for Acceptance Testing](#)” task on page [4-16](#) for the TXP containing the wavelength you will test.

- Step 13** Connect the tunable laser transmitter or the TXP_MR_10E_L card DWDM TX port to the east OPT-BST-L or OSC-CSM LINE RX port. If an east OPT-AMP-L card is installed, insert a 10-dB attenuator on the fiber coming from the TXP_MR_10E_L card.

**Caution**

Failure to use proper attenuation might damage equipment.

- Step 14** If an OPT-AMP-L card configured as an OPT-PRE is installed on the east side, complete the following steps. If not, continue with [Step 15](#).
- Display the east OPT-AMP-L card in card view.
 - Click the **Provisioning > Optical Line > Parameters** tabs.
 - Locate the Power parameter for Port 1. Record the value.
 - Display the east OPT-BST-L or OSC-CSM card in card view.
 - Click the **Provisioning > Optical Line > Parameters** tabs.
 - Locate the Power value for Port 2 (if an OPT-BST-L card) or Port 3 (if an OSC-CSM card). Verify that the value matches the power recorded in Step [c](#), +/- 1.5 dB. If not, use the “[NTP-G115 Clean Fiber Connectors](#)” procedure on page 13-25 to clean the fiber connection between the OPT-AMP-L card and the OPT-BST-L or OSC-CSM card. Check the values again. If they still do not match, contact your next level of support.
 - Complete the “[DLP-G360 Verify the OPT-AMP-L \(OPT-PRE Mode\) Amplifier Laser and Power](#)” task on page 4-18.
- Step 15** If MMU cards are installed complete the following steps. If an MMU cards are not installed, continue with [Step 16](#).
- Display the east MMU card in card view.
 - Click the **Provisioning > Optical Line > Parameters** tabs.
 - Locate the Port 3 (COM-RX) power parameter. Record the value.
 - If an east OPT-AMP-L card provisioned as an OPT-PRE is installed, display it in card view and complete Step [e](#). If not, continue with Step [f](#).
 - Click the OPT-AMP-L **Provisioning > Opt.Ampli.Line > Parameters** tabs and read the Total Output Power value for Port 2 (COM-TX), then continue with Step [i](#).
 - If an east OPT-BST-L card is installed, display it in card view and complete Step [g](#). If not, continue with Step [h](#).
 - Click the **Provisioning > Optical Line > Parameters** tabs and read the Power value for Port 2 (COM-TX), then continue with Step [i](#).
 - Display the east OSC-CSM card in card view, click the **Provisioning > Optical Line > Parameters** tabs and read the Power value for Port 3 (COM-TX), then continue with Step [i](#).
 - Verify that value in Step [e](#), [g](#), or [h](#) matches the power recorded in Step [c](#), +/- 1.0 dB. If not, use the “[NTP-G115 Clean Fiber Connectors](#)” procedure on page 13-25 to clean the fiber connection between the MMU card and the OPT-BST-L, OPT-AMP-L, or OSC-CSM cards. Check the values again. If they still do not match, contact your next level of support.
 - Display the east MMU card in card view.
 - Click the **Provisioning > Optical Line > Parameters** tabs.
 - Record the value in the Power table cell for Port 2(EXP-TX) of the east MMU card.
 - Display the east 32WSS-L card in card view.

- n. Click the **Provisioning > Optical Line > Parameters** tabs.
 - o. Verify that the value in the Power table cell for Port 68 (COM-RX) is equal to the value recorded in Step 1, +/- 1.0 dB. If not, use the “[NTP-G115 Clean Fiber Connectors](#)” procedure on page 13-25 to clean the fiber connection between the 32WSS and MMU cards. Check the values again. If they still do not match, contact your next level of support.
 - p. Continue with [Step 17](#).
- Step 16** Verify the east 32WSS-L to OPT-BST-L, OPT-AMP-L, or OSC-CSM card cable connection:
- a. Display the east 32WSS-L card in card view.
 - b. Click the **Provisioning > Optical Line > Parameters** tabs.
 - c. Locate the Port 68 Power parameter. Record the value.
 - d. If an east OPT-AMP-L card provisioned as an OPT-PRE is installed, display it in card view and complete Step e. If not, continue with Step f.
 - e. Click the **Provisioning > Opt.Ampli.Line > Parameters** tabs and read the Total Output Power value for Port 2, then continue with Step i.
 - f. If an east OPT-BST-L card is installed, display it in card view and complete Step g. If not, continue with Step h.
 - g. Click the **Provisioning > Opt.Ampli.Line > Parameters** tabs and read the Power value for Port 3, then continue with Step i.
 - h. Display the east OSC-CSM card in card view, click the **Provisioning > Optical Line > Parameters** tabs and read the Power value for Port 2, then continue with Step i.
 - i. Verify that the value in Step e, g, or h matches the power recorded in Step c, +/- 1.5 dB. If not, use the “[NTP-G115 Clean Fiber Connectors](#)” procedure on page 13-25 to clean the fiber connection between the 32WSS-L card and the OPT-AMP-L, OPT-BST-L, or OSC-CSM card. Check the values again. If they still do not match, contact your next level of support.
- Step 17** Verify the EXPRESS cable connection between the two 32WSS-L cards:
- a. Display the east 32WSS-L card in card view.
 - b. Click the **Provisioning > Optical Line > Parameters** tabs.
 - c. Locate the Port 65 (EXP-TX) Power parameter. Record the value.
 - a. Display the west 32WSS-L card in card view.
 - b. Click the **Provisioning > Optical Line > Parameters** tabs.
 - c. Locate the Power value for Port 66 (EXP-RX). Verify that the value matches the power recorded in Step c, +/-1 dB. If not, use the “[NTP-G115 Clean Fiber Connectors](#)” procedure on page 13-25 to clean the fiber connection between the 32WSS-L cards. Check the values again. If they still do not match, contact your next level of support.
- Step 18** Display the west 32WSS-L card in card view.
- Step 19** Click the **Provisioning > Optical Chn Optical Connector_n > Parameters** tabs, where *n* = the connector number containing the wavelength you are testing. Refer to [Table 4-2 on page 4-43](#), if needed.
- Step 20** Wait 60 to 70 seconds, then locate the Power and VOA Power Ref parameters for the tested PASS-THROUGH port. Verify that the Power value is equal to the VOA Power Ref value, +/- 1.5 dBm. If the Power value is not equal to the VOA Power Ref value, +/- 1.5 dBm, contact your next level of support.

- Step 21** If an MMU card is installed on the west side, complete the following steps. If an MMU card is not installed on the west side, continue with [Step 22](#).
- a. Display the west 32WSS-L card in card view.
 - b. Click the **Provisioning > Optical Line > Parameters** tabs.
 - c. Record the value in the Power table cell for Port 67(COM-TX).
 - d. Display the west MMU card in card view.
 - e. Click the **Provisioning > Optical Line > Parameters** tabs.
 - f. Verify that the value in the Power table cell for Port 1(EXP-RX) is equal to the value recorded in Step c, +/- 1.0 dB. If not, use the “[NTP-G115 Clean Fiber Connectors](#)” procedure on page 13-25 to clean the fiber connection between the 32WSS and MMU cards. Check the values again. If they still do not match, contact your next level of support.
 - g. Record the value in the Power table cell for Port 4 (COM-TX).
 - h. If an OPT-BST-L card is installed on the west side, display it in card view and complete Step i. If not, continue with Step j.
 - i. Click the **Provisioning > Optical Line > Parameters** tabs and read the Power value for Port 1 (COM-RX), then continue with Step k.
 - j. Display the west OSC-CSM card in card view, click the **Provisioning > Optical Line > Parameters** tabs and read the Power value for Port 2 (COM-RX), then continue with Step k.
 - k. Verify that the value in Step i or j matches the power recorded in Step g, +/- 1.5 dB. If not, use the “[NTP-G115 Clean Fiber Connectors](#)” procedure on page 13-25 to clean the fiber connection between the OPT-BST-L, or OSC-CSM and MMU cards. Check the values again. If they still do not match, contact your next level of support.
 - l. Continue with [Step 23](#).
- Step 22** If an OPT-BST-L card is installed on the east side, complete the following steps. If not, continue with [Step 23](#).
- a. Display the east OPT-BST-L card in card view.
 - b. Click the **Provisioning > Optical Line > Parameters** tabs.
 - c. Locate the Port 1 Power parameter. Record the value.
 - d. Display the east 32WSS-L card in card view.
 - e. Click the **Provisioning > Optical Line > Parameters** tabs.
 - f. Locate the Power value for Port 67. Verify that the value matches the power recorded in Step c, +/-1 dB. If not, use the “[NTP-G115 Clean Fiber Connectors](#)” procedure on page 13-25 to clean the fiber connection between the OPT-BST-L and 32WSS-L cards. Check the values again. If they still do not match, contact your next level of support.
 - g. Complete the “[DLP-G79 Verify the OPT-BST, OPT-BST-E, or OPT-BST-L Amplifier Laser and Power](#)” task on page 4-5.
- Step 23** If a west OPT-AMP-L card provisioned as an OPT-PRE is installed, complete the following steps. If not, continue with [Step 24](#).
- a. Display the west OPT-AMP-L card in card view.
 - b. Click the **Provisioning > Optical Line > Parameters** tabs.
 - c. Locate the Power parameter for Port 1 (COM-RX). Record the value.
 - d. Display the west OPT-BST-L or OSC-CSM card in card view.

- e. Click the **Provisioning > Optical Line > Parameters** tabs.
- f. Locate the Power value for Port 2 (COM-TX) (OPT-BST-L) or Port 3 (COM-TX) (OSC-CSM). Verify that the value matches the power recorded in Step c, +/- 2.0 dB. If not, use the “[NTP-G115 Clean Fiber Connectors](#)” procedure on page 13-25 to clean the fiber connection between the OPT-AMP-L card and the OPT-BST-L or OSC-CSM card. Check the values again. If they still do not match, contact your next level of support.
- g. For the west OPT-AMP-L card provisioned as an OPT-PRE, complete the “[DLP-G360 Verify the OPT-AMP-L \(OPT-PRE Mode\) Amplifier Laser and Power](#)” task on page 4-18.

Step 24 If an MMU card is installed on the west side, complete the following steps, then continue with [Step 26](#). If an MMU card is not installed on the west side, continue with [Step 25](#).

- a. Display the west MMU card in card view.
- b. Click the **Provisioning > Optical Line > Parameters** tabs.
- c. Locate the Port 3 (COM-RX) power parameter. Record the value.
- d. If an west OPT-AMP-L card provisioned in OPT-PRE mode is installed, display it in card view and complete Step e. If not, continue with Step f.
- e. Click the OPT-AMP-L **Provisioning > Opt.Ampli.Line > Parameters** tabs and read the Total Output Power value for Port 2 (COM-TX), then continue with Step i.
- f. If an OPT-BST-L card is installed on the west side, display it in card view and complete Step g. If not, continue with Step h.
- g. Click the **Provisioning > Optical Line > Parameters** tabs and read the Power value for Port 2 (COM-TX), then continue with Step i.
- h. Display the west OSC-CSM card in card view, click the **Provisioning > Optical Line > Parameters** tabs and read the Power value for Port 3 (COM-TX), then continue with Step i.
- i. Verify that value in the Step e, g, or h matches the power recorded in Step c, +/- 1.0 dB. If not, use the “[NTP-G115 Clean Fiber Connectors](#)” procedure on page 13-25 to clean the fiber connection between the MMU card and the OPT-BST-L, OPT-AMP-L, or OSC-CSM cards. Check the values again. If they still do not match, contact your next level of support.
- j. Display the east MMU card in card view.
- k. Click the **Provisioning > Optical Line > Parameters** tabs.
 - l. Record the value in the Power table cell for Port 2(EXP-TX) of the west MMU card.
- m. Display the west 32WSS-L card in card view.
- n. Click the **Provisioning > Optical Line > Parameters** tabs.
- o. Verify that the value in the Power table cell for Port 68 (COM-RX) is equal to the value recorded in Step l, +/- 1.0 dB. If not, use the “[NTP-G115 Clean Fiber Connectors](#)” procedure on page 13-25 to clean the fiber connection between the 32WSS and cards and the MMU cards. Check the values again. If they still do not match, contact your next level of support.
- p. Continue with [Step 26](#).

Step 25 Verify the west 32WSS-L card to OPT-BST-L, OPT-AMP-L, or OSC-CSM card cable connection:

- a. Display the west 32WSS-L card in card view.
- b. Click the **Provisioning > Optical Line > Parameters** tabs.
- c. Locate the Port 68 (COM-RX) Power parameter. Record the value.
- d. If a west OPT-AMP-L card is installed, display it in card view, and complete Step e. If not, continue with Step f.

- e. Click the **Provisioning > Opt.Ampli.Line > Parameters** tabs and read the Total Output Power value for Port 2 (COM-TX), then continue with Step [i](#).
- f. If a west OPT-BST-L card is installed, display it in card view, and complete Step [g](#). If not, continue with Step [h](#).
- g. Click the **Provisioning > Opt.Ampli.Line > Parameters** tabs and read the Power value for Port 2 (COM-TX), then continue with Step [i](#).
- h. Display the west OSC-CSM card in card view, click the **Provisioning > Opt.Ampli.Line > Parameters** tabs and read the Power value for Port 3 (COM-TX), then continue with Step [i](#).
- i. Verify that the value in Step [e](#), [g](#), or [h](#) matches the power recorded in Step [c](#), +/-1.5 dB. If not, use the “[NTP-G115 Clean Fiber Connectors](#)” procedure on page 13-25 to clean the fiber connection between the 32WSS-L card and the OPT-AMP-L, OPT-BST-L, or OSC-CSM card. Check the values again. If they still do not match, contact your next level of support.

Step 26 Verify the EXPRESS cable connection between the two 32WSS-L cards:

- a. Display the west 32WSS-L card in card view.
- b. Click the **Provisioning > Optical Line > Parameters** tabs.
- c. Locate the Port 65 (EXP-TX) Power parameter. Record the value.
- a. Display the east 32WSS-L card in card view.
- b. Click the **Provisioning > Optical Line > Parameters** tabs.
- c. Locate the Power value for Port 66 (EXP-RX). Verify that the value matches the power recorded in Step [c](#), +/- 1 dB. If not, use the “[NTP-G115 Clean Fiber Connectors](#)” procedure on page 13-25 to clean the fiber connection between the 32WSS-L cards. Check the values again. If they still do not match, contact your next level of support.

Step 27 Display the east 32WSS-L card in card view.

Step 28 Click the **Provisioning > Optical Chn Optical Connector n > Parameters** tabs, where n = the connector number containing the wavelength you are testing. Refer to [Table 4-1 on page 4-21](#), if needed.

Step 29 Wait 60 to 70 seconds (or click **Reset**), then locate the Power and VOA Power Ref parameters for the tested PASS-THROUGH port. Verify that the Power value is equal to the VOA Power Ref value, +/-1.5 dBm. If the Power value is not equal to the VOA Power Ref value +/-1.5 dBm, consult your next level of support.

Step 30 If an MMU card is installed on the east side, complete the following steps. If an MMU card is not installed on the east side, continue with [Step 31](#).

- a. Display the east 32WSS-L card in card view.
- b. Click the **Provisioning > Optical Line > Parameters** tabs.
- c. Record the value in the Power table cell for Port 67(COM-TX).
- d. Display the east MMU card in card view.
- e. Click the **Provisioning > Optical Line > Parameters** tabs.
- f. Verify that the value in the Power table cell for Port 1(EXP-RX) is equal to the value recorded in Step [c](#), +/- 1.0 dB. If not, use the “[NTP-G115 Clean Fiber Connectors](#)” procedure on page 13-25 to clean the fiber connection between the 32WSS-L and MMU cards. Check the values again. If they still do not match, contact your next level of support.
- g. Record the value in the Power table cell for Port 4 (COM-TX).
- h. If a east OPT-BST-L card is installed, display it in card view and complete Step [i](#). If not, continue with Step [j](#).

- i. Click the **Provisioning > Optical Line > Parameters** tabs and read the Power value for Port 1 (COM-RX), then continue with Step [k](#).
 - j. Display the east OSC-CSM card in card view, click the **Provisioning > Optical Line > Parameters** tabs and read the Power value for Port 2 (COM-RX), then continue with Step [k](#).
 - k. Verify that the value in Step [i](#) or [j](#) matches the power recorded in Step [g](#), +/- 1.5 dB. If not, use the “[NTP-G115 Clean Fiber Connectors](#)” procedure on page 13-25 to clean the fiber connection between the OPT-BST-L, or OSC-CSM and MMU cards. Check the values again. If they still do not match, contact your next level of support.
 - l. Continue with [Step 32](#).
- Step 31** If an OPT-BST-L or OSC-CSM card is installed on the east side, complete the following steps. If not, continue with [Step 32](#).
- a. Display the east OPT-BST-L or OSC-CSM card in card view.
 - b. Click the **Provisioning > Optical Line > Parameters** tabs.
 - c. Locate the Port 1 (COM-RX) Power parameter (OPT-BST-L card) or the Port 2 (COM-RX) Power parameter (OSC-CSM card). Record the value.
 - d. Display the east 32WSS-L card in card view.
 - e. Click the **Provisioning > Optical Line > Parameters** tabs.
 - f. Locate the Power value for Port 67 (COM-TX). Verify that the value matches the power recorded in Step [c](#), +/-1 dB. If not, use the “[NTP-G115 Clean Fiber Connectors](#)” procedure on page 13-25 to clean the fiber connection between the OPT-BST-L and OSC-CSM or 32WSS-L cards. Check the values again. If they still do not match, contact your next level of support.
 - g. Complete the “[DLP-G79 Verify the OPT-BST, OPT-BST-E, or OPT-BST-L Amplifier Laser and Power](#)” task on page 4-5.
- Step 32** Repeat Steps [18](#), [19](#), [27](#) and [28](#) for the remaining wavelengths to be tested. If you have tested all the wavelengths, continue with [Step 33](#).
- Step 33** Display the east 32WSS-L card in card view.
- Step 34** Click the **Maintenance** tab.
- Step 35** Under Operating Mode, click the table cell and choose **Not Assigned** from the drop-down list for all wavelengths.
- Step 36** Click **Apply**, then click **Yes** to confirm.
- Step 37** Display the west 32WSS-L in card view.
- Step 38** Repeat Steps [34](#) through [36](#) for the west 32WSS-L card.
- Step 39** Remove the TXP or tunable laser from the east OPT-BST-L or OSC-CSM line side TX and RX ports.
- Step 40** Remove the loopback fiber from the line RX and TX in the west OPT-BST-L or OSC-CSM card.
- Step 41** Return to your originating procedure (NTP).
-

DLP-G363 Verify the East ROADM L-Band Add/Drop Channels

Purpose	This procedure verifies the signal flow through the east side of a ROADM node for L-band add/drop channels.
Tools/Equipment	One of the following: <ul style="list-style-type: none"> • A tunable laser • TXP_MR_10E_L An optical power meter or optical spectrum analyzer 2 bulk attenuators (10 dB) with LC connectors
Prerequisite Procedures	“DLP-G46 Log into CTC” task on page 2-25
Required/As Needed	Required
Onsite/Remote	Onsite
Security Level	Superuser



Note Throughout this task, west refers to Slots 1 through 8, and east refers to Slots 10 through 17.

- Step 1** In node view (single-shelf mode) or multishelf view (multishelf mode), display the Alarms tab.
- Step 2** Create a physical loopback on the east OPT-BST-L or OSC-CSM card by connecting the LINE TX port to its LINE RX port. For OPT-BST-L cards, connect a 10-dB bulk attenuator to the fiber. (OSC-CSM cards do not require attenuation.)



Caution Failure to use proper attenuation might damage equipment.

- Step 3** Wait 2 to 3 minutes, then click the **Alarms** tab. Verify that the LOS alarms on the east OSCM or OSC-CSM card and the OPT-BST-L card have cleared. The clearing of the LOS alarms indicates that the OSC link is active on the east side.



Note An SDCC Termination Failure alarm will continue to appear due to the OSC signal loopback.

- Step 4** If you are using a tunable laser, follow the manufacturer’s instructions to complete the following steps. If you are using a TXP_MR_10E_L card, continue with [Step 5](#).
- Set the output power to a nominal value, such as -3 dBm.
 - Set the tuner to the wavelength you are testing, then continue with [Step 7](#).
- Step 5** If you are using a TXP_MR_10E_L card, complete the [“DLP-G358 Provision TXP_MR_10E_L Card for Acceptance Testing” task on page 4-16](#) for the TXP containing the wavelength you will test. Refer to [“Table 4-232 WSS-L Ports and Wavelengths Test Checklist” task on page 4-43](#), if needed.
- Step 6** If you are using a TXP_MR_10E_L card, complete the following steps. If you are using a tunable laser, continue with [Step 7](#).
- Display the TXP_MR_10E_L in card view.
 - Click the **Performance > Optics PM > Current Values** tabs.
 - Locate the Port 2 (Trunk) table cell for the TX Optical Pwr parameter. Record the value.

- Step 7** Connect the tunable laser transmitter or the TXP_MR_10E_L card DWDM TX port to the east side fiber patch panel MUX port that corresponds to the east 32WSS-L card port carrying the tested wavelength.
- Step 8** Connect the TXP_MR_10E_L DWDM RX port or the power meter RX port to the east side fiber patch panel DMX port that is connected with the east 32DMX-L card CHAN-TX port carrying the tested wavelength. (If the TXP_MR_10E_L card was installed during [Chapter 3, “Turn Up a Node,”](#) simply verify the cable connection.)
- Step 9** Display the 32WSS-L card in card view.
- Step 10** Click the **Maintenance** tab.
- Step 11** For each wavelength that you will test, click the table cell under Operating Mode and choose **Add Drop** from the drop-down list.
- Step 12** Click **Apply** and then **Yes**, to confirm.
- Step 13** Click the **Provisioning > Optical Chn Optical Connector n > Parameters** tabs, where n = the optical connector number that carries the wavelengths you will test. Refer to [Table 4-2 on page 4-43](#), if needed.
- Step 14** Find the tested wavelength CHAN RX port, then scroll to the right until you see the Power Add parameter. Verify that the Power Add value for the tested port CHAN RX is equal to the output power level of the tunable laser or the TXP_MR_10E_L card measured in [Step 6](#) +/- 1 dBm.
- Step 15** Click the **Provisioning > Optical Line > Parameters** tabs and record the value in the Power table cell for Port 67 (COM-TX) for the wavelength under test.
- Step 16** Verify that the power value from [Step 15](#) reaches the EastSide.Tx.Power.Add&Drop - Output Power set +/- 1 dBm. To view this setpoint:
- In node view (single-shelf mode) or multishelf view (multishelf mode), click the **Provisioning > WDM-ANS > Provisioning** tabs.
 - In the Selector window on the left, expand the **East Side** parameters tree view.
 - Expand the **TX** category.
 - Expand the **Power** category, then highlight **Add&Drop - Output Power**.
 - View the EastSide.TxPower.Add&Drop - Output Power parameter on the right pane.
 - If the power value does not match the value recorded in [Step 15](#), +/- 2dBm, contact your next level of support.
- Step 17** If an MMU card is installed on the east side, complete the following steps. If an MMU card is not installed on the east side, continue with [Step 18](#).
- Display the east 32WSS-L card in card view.
 - Click the **Provisioning > Optical Line > Parameters** tabs.
 - Record the value in the Power table cell for Port 67 (COM-TX).
 - Display the east MMU card in card view.
 - Click the **Provisioning > Optical Line > Parameters** tabs.
 - Verify that the value in the Power table cell for Port 1(EXP-RX) is equal to the value recorded in [Step c](#), +/- 1.0 dB. If not, use the [“NTP-G115 Clean Fiber Connectors” procedure on page 13-25](#) to clean the fiber connection between the 32WSS-L and MMU cards. Check the values again. If they still do not match, contact your next level of support.
 - Record the value in the Power table cell for Port 4 (COM-TX).
 - If a east OPT-BST-L card is installed, display it in card view and complete [Step i](#). If not, continue with [Step j](#).

- i. Click the Provisioning > Optical Line > Parameters tabs and read the Power value for Port 1 (COM-RX), then continue with Step k.
- j. Display the east OSC-CSM card in card view, click the **Provisioning > Optical Line > Parameters** tabs and read the Power value for Port 2 (COM-RX), then continue with Step k.
- k. Verify that the value in Step i or j matches the power recorded in Step g, +/- 1.5 dB. If not, use the “[NTP-G115 Clean Fiber Connectors](#)” procedure on page 13-25 to clean the fiber connection between the OPT-BST-L or OSC-CSM and MMU cards. Check the values again. If they still do not match, contact your next level of support.
- l. Continue with Step 19.

Step 18 Verify the connection between the 32WSS-L and OPT-BST-L or OSC_CSM cards:

- a. Display the east 32WSS-L card in card view.
- b. Click the **Provisioning > Optical Line > Parameters** tabs.
- c. Record the value in the Power table cell for Port 67 (COM-TX).
- d. If a OPT-BST-L card is installed on the east side, display it in card view and complete Step e. If not, continue with Step f.
- e. Click the **Provisioning > Optical Line > Parameters** tabs and read the Power value for Port 1 (COM-RX), then continue with Step g.
- f. Display the east OSC-CSM card in card view, click the **Provisioning > Optical Line > Parameters** tabs and read the Power value for Port 2 (COM-RX), then continue with Step g.
- g. Verify that the value in Step e or f matches the power recorded in Step c, +/- 1.0 dB. If so, continue with Step 19. If not, use the “[NTP-G115 Clean Fiber Connectors](#)” procedure on page 13-25 to clean the fiber connection between the OPT-BST-L or OSC-CSM and 32WSS-L cards. Check the values again. If they still do not match, contact your next level of support.

Step 19 If an OPT-AMP-L card provisioned in OPT-PRE mode is installed on the east side, complete the following steps. If not, continue with Step 20.

- a. Display the east OPT-AMP-L card in card view.
- b. Click the **Provisioning > Optical Line > Parameters** tabs.
- c. Locate the Power parameter for Port 1 (COM-RX). Record the value.
- d. Display the east OPT-BST-L or OSC-CSM card in card view.
- e. Click the **Provisioning > Optical Line > Parameters** tabs.
- f. Locate the Port 2 (COM-TX) Power value (for OPT-BST-L cards) or Port 3 (COM-TX) Power value (for OSC-CSM card). Verify that the value matches the power recorded in Step c, +/- 1.5 dB. If not, use the “[NTP-G115 Clean Fiber Connectors](#)” procedure on page 13-25 to clean the fiber connection between the OPT-AMP-L card and the OPT-BST-L or OSC-CSM card. Check the values again. If they still do not match, contact your next level of support.
- g. For the east OPT-AMP-L card, complete the “[DLP-G80 Verify the OPT-PRE Amplifier Laser and Power](#)” task on page 4-6.

Step 20 If an MMU card is installed on the east side, complete the following steps. If an MMU card is not installed on the east side, continue with Step 21.

- a. Display the east MMU card in card view.
- b. Click the **Provisioning > Optical Line > Parameters** tabs.
- c. Locate the Port 68 (COM-RX) Power parameter. Record the value.

- d. If an OPT-AMP-L card provisioned in OPT-PRE mode is installed on the east side, display it in card view and complete Step e. If not, continue with Step f.
- e. Click the OPT-PRE **Provisioning > Opt.Ampli.Line > Parameters** tabs. Record the Total Output Power value for Port 2 (COM-TX), then continue with Step i.
- f. If an east OPT-BST-L card is installed, display it in card view and complete Step g. If not, continue with Step h.
- g. Click the Provisioning > Optical Line > Parameters tabs and read the Power value for Port 2 (COM-TX), then continue with Step i.
- h. Display the east OSC-CSM card in card view, click the Provisioning > Optical Line > Parameters tabs and read the Power value for Port 3 (COM-TX), then continue with Step i.
- i. Verify that value in the Step e, g, or h matches the power recorded in Step e, +/- 1.0 dB. If not, use the “[NTP-G115 Clean Fiber Connectors](#)” procedure on page 13-25 to clean the fiber connection between the MMU card and the OPT-BST-L or OSC-CSM cards. Check the values again. If they still do not match, contact your next level of support.
- j. Display the east MMU card in card view.
- k. Click the **Provisioning > Optical Line > Parameters** tabs.
 - l. Record the value in the Power table cell for Port 2 (EXP-TX).
- m. Display the east 32WSS-L card in card view.
- n. Click the **Provisioning > Optical Line > Parameters** tabs.
- o. Verify that the value in the Power table cell for Port 68 (COM-RX) is equal to the value recorded in Step l, +/- 1.0 dB. If not, use the “[NTP-G115 Clean Fiber Connectors](#)” procedure on page 13-25 to clean the fiber connection between the 32WSS-L and MMU cards. Check the values again. If they still do not match, contact your next level of support.
- p. Continue with [Step 22](#).

Step 21 Verify the connection between the east 32WSS-L card and the OPT-BST-L, OPT-AMP-L (in OPT-PRE mode), or OSC-CSM card:

- a. Display the east 32WSS-L in card view.
- b. Click the **Provisioning > Optical Line > Parameters** tabs.
- c. Locate the Port 68 (COM-RX) Power parameter. Record the value.
- d. If an east OPT-AMP-L card provisioned in OPT-PRE mode is installed, display it in card view and complete Step e. If not, continue with Step f.
- e. Click the **Provisioning > Opt.Ampli.Line > Parameters** tabs and read the Total Output Power value for Port 2 (COM-TX), then continue with Step i.
- f. If an east OPT-BST-L card is installed, display it in card view and complete Step g. If not, continue with Step h.
- g. Click the **Provisioning > Optical Line > Parameters** tabs and read the Power value for Port 2 (COM-TX), then continue with Step i.
- h. Display the east OSC-CSM card in card view. Click the **Provisioning > Optical Line > Parameters** tabs and read the Power value for Port 3 (COM-TX), then continue with Step i.
- i. Verify that the value in Step e, g, or h matches the power recorded in Step c, +/- 1.5 dB. If not, use the “[NTP-G115 Clean Fiber Connectors](#)” procedure on page 13-25 to clean the fiber connection between the 32WSS-L card and the OPT-AMP-L, OPT-BST-L, or OSC-CSM card.

- Step 22** Verify the east 32WSS-L and 32DMX-L connection:
- Display the east 32WSS-L card in card view.
 - Click the **Provisioning > Optical Line > Parameters** tabs, and record the value in the Power table cell for Port 69 (DROP-TX).
 - Display the east 32DMX-L card in card view.
 - Click the **Provisioning > Optical Line > Parameters** tabs. Record the value in the Port 2 (COM-RX) table cell. Verify that the value is equal to the value recorded in **b.**, ± 1 dBm. If not, use the [“NTP-G115 Clean Fiber Connectors” procedure on page 13-25](#) to clean the fiber connection between the 32WSS-L and 32DMX-L cards. Check the values again. If they still do not match, contact your next level of support.
- Step 23** Display the east 32DMX-L card in card view.
- Step 24** Click the **Provisioning > Optical Chn > Parameters** tab. Record the CHAN-TX port value under the Power parameter for the wavelength under test.
- Step 25** Verify that the power value from [Step 24](#) reaches the EastSide.Rx.Power.Add&Drop - Drop Power setpoint ± 2 dBm. To view this setpoint:
- Go to node view (single-shelf mode) or multishelf view (multishelf mode) and click the **Provisioning > WDM-ANS > Provisioning** tabs.
 - In the Selector window on the left, expand the **East Side** parameters tree view.
 - Expand the **RX** category.
 - Expand the **Power** category, then highlight **Add&Drop - Drop Power**.
 - View the EastSide.Rx.Power.Add&Drop - Drop Power parameter on the right pane.
 - If the power value does not match the value recorded in [Step 24](#) (± 2 dBm), contact your next level of support.
- Step 26** Display the TXP_MR_10E_L card in card view.
- Step 27** Click the **Performance > Optics PM > Current Values** tabs.
- Step 28** In the Port 2 (Trunk) column, locate the RX Optical Power value. Verify that the value matches the power in [Step 24](#), ± 2 dBm. If the power values do not match (± 2 dBm), complete the following steps:
- Remove, clean, and replace the cable connecting the TXP_MR_10E_C RX port to the east fiber patch panel DMX port for the tested wavelength. See the [“NTP-G115 Clean Fiber Connectors” procedure on page 13-25](#).
 - Repeat this step. If the power values still do not match (± 2 dBm) contact your next level of support.
- Step 29** Repeat Steps [4](#) through [28](#) for the remaining wavelengths.
- Step 30** Display the east 32WSS-L card in card view.
- Step 31** Click the **Maintenance** tab.
- Step 32** Click the table cell under Operating Mode and choose **Not Assigned** from the drop-down list for all wavelengths.
- Step 33** Click **Apply**, then click **Yes** to confirm.
- Step 34** Disconnect the TXP or tunable laser from the east side patch panel.
- Step 35** Unplug the physical loopback fiber from the line TX and RX in the OPT-BST-L or OSC-CSM card.

Step 36 Return to your originating procedure (NTP).

DLP-G364 Verify the West ROADM L-Band Add/Drop Channels

Purpose	This procedure verifies the signal flow through the west side of a ROADM node for L-band add/drop channels.
Tools/Equipment	One of the following: <ul style="list-style-type: none"> • A tunable laser • TXP_MR_10E_L An optical power meter or optical spectrum analyzer 2 bulk attenuators (10 dB) with LC connectors
Prerequisite Procedures	“DLP-G46 Log into CTC” task on page 2-25
Required/As Needed	Required
Onsite/Remote	Onsite
Security Level	Superuser



Note Throughout this task, west refers to Slots 1 through 8, and east refers to Slots 10 through 17.

- Step 1** In node view (single-shelf mode) or multishelf view (multishelf mode), display the Alarms tab.
- Step 2** Create a physical loopback on the west OPT-BST-L or OSC-CSM card by connecting the LINE TX port to its LINE RX port. For OPT-BST-L cards, connect a 10-dB bulk attenuator to the fiber. (OSC-CSM cards do not require attenuation.)



Caution Failure to use proper attenuation might damage equipment.

- Step 3** Wait 2 to 3 minutes, then click the **Alarms** tab. Verify that the LOS alarms on the west OSCM or OSC-CSM card and the OPT-BST-L card have cleared. The clearing of the LOS alarms indicates that the OSC link is active on the west side.



Note An SDCC Termination Failure alarm will continue to appear due to the OSC signal loopback.

- Step 4** If you are using a tunable laser, follow the manufacturer’s instructions to complete the following steps. If you are using a TXP_MR_10E_L card, continue with [Step 5](#).
- Set the output power to a nominal value, such as -3 dBm.
 - Set the tuner to the wavelength you are testing, then continue with [Step 7](#).
- Step 5** If you are using a TXP_MR_10E_L card, complete the [“DLP-G358 Provision TXP_MR_10E_L Card for Acceptance Testing” task on page 4-16](#) for the TXP containing the wavelength you will test. Refer to [“Table 4-232WSS-L Ports and Wavelengths Test Checklist” task on page 4-43](#), if needed.

- Step 6** If you are using a TXP_MR_10E_L card, complete the following steps. If you are using a tunable laser, continue with [Step 7](#).
- Display the TXP_MR_10E_L in card view.
 - Click the **Performance > Optics PM > Current Values** tabs.
 - Locate the Port 2 (Trunk) table cell for the TX Optical Pwr parameter. Record the value.
- Step 7** Connect the tunable laser transmitter or the TXP_MR_10E_L card DWDM TX port to the west side fiber patch panel MUX port that corresponds to the west 32WSS-L card port carrying the tested wavelength.
- Step 8** Connect the TXP_MR_10E_L DWDM RX port or the power meter RX port to the west side fiber patch panel DMX port that is connected with the west 32DMX-L card CHAN-TX port carrying the tested wavelength. (If the TXP_MR_10E_L card was installed during [Chapter 3, “Turn Up a Node,”](#) simply verify the cable connection.)
- Step 9** Display the 32WSS-L card in card view.
- Step 10** Click the **Maintenance** tab.
- Step 11** For each wavelength that you will test, click the table cell under Operating Mode and choose **Add Drop** from the drop-down list.
- Step 12** Click **Apply** and then **Yes**, to confirm.
- Step 13** Click the **Provisioning > Optical Chn Optical Connector_n > Parameters** tabs, where *n* = the optical connector number that carries the wavelengths you will test. Refer to [Table 4-2 on page 4-43](#), if needed.
- Step 14** Find the tested wavelength CHAN RX port, then scroll to the right until you see the Power Add parameter. Verify that the Power Add value for the tested port CHAN RX is equal to the output power level of the tunable laser or the TXP_MR_10E_L card measured in [Step 6](#) +/- 1 dBm.
- Step 15** Click the **Provisioning > Optical Line > Parameters** tabs and record the value in the Power table cell for Port 67 (COM-TX) for the wavelength under test.
- Step 16** Verify that the power value from [Step 15](#) reaches the WestSide.Tx.Power.Add&Drop - Output Power set +/- 1 dBm. To view this setpoint:
- In node view (single-shelf mode) or multishelf view (multishelf mode), click the **Provisioning > WDM-ANS > Provisioning** tabs.
 - In the Selector window on the left, expand the **West Side** parameters tree view.
 - Expand the **TX** category.
 - Expand the **Power** category, then highlight **Add&Drop - Output Power**.
 - View the WestSide.TxPower.Add&Drop - Output Power parameter on the right pane.
 - If the power value does not match the value recorded in [Step 15](#), +/- 2dBm, contact your next level of support.
- Step 17** If an MMU card is installed on the west side, complete the following steps. If an MMU card is not installed on the west side, continue with [Step 18](#).
- Display the west 32WSS-L card in card view.
 - Click the **Provisioning > Optical Line > Parameters** tabs.
 - Record the value in the Power table cell for Port 67 (COM-TX).
 - Display the west MMU card in card view.
 - Click the **Provisioning > Optical Line > Parameters** tabs.

- f. Verify that the value in the Power table cell for Port 1 (EXP-RX) is equal to the value recorded in Step c, +/- 1.0 dB. If not, use the “[NTP-G115 Clean Fiber Connectors](#)” procedure on page 13-25 to clean the fiber connection between the 32WSS-L and MMU cards. Check the values again. If they still do not match, contact your next level of support.
- g. Record the value in the Power table cell for Port 4 (COM-TX).
- h. If a west OPT-BST-L card is installed, display it in card view and complete Step i. If not, continue with Step j.
- i. Click the Provisioning > Optical Line > Parameters tabs and read the Power value for Port 1 (COM-RX), then continue with Step k.
- j. Display the west OSC-CSM card in card view, click the **Provisioning > Optical Line > Parameters** tabs and read the Power value for Port 2 (COM-RX), then continue with Step k.
- k. Verify that the value in Step i or j matches the power recorded in Step g, +/- 1.5 dB. If not, use the “[NTP-G115 Clean Fiber Connectors](#)” procedure on page 13-25 to clean the fiber connection between the OPT-BST-L or OSC-CSM and MMU cards. Check the values again. If they still do not match, contact your next level of support.
- l. Continue with [Step 19](#).

Step 18 Verify the connection between the 32WSS-L and OPT-BST-L or OSC_CSM cards:

- a. Display the west 32WSS-L card in card view.
- b. Click the **Provisioning > Optical Line > Parameters** tabs.
- c. Record the value in the Power table cell for Port 67 (COM-TX).
- d. If a OPT-BST-L card is installed on the west side, display it in card view and complete Step e. If not, continue with Step f.
- e. Click the **Provisioning > Optical Line > Parameters** tabs and read the Power value for Port 1 (COM-RX), then continue with Step g.
- f. Display the west OSC-CSM card in card view, click the **Provisioning > Optical Line > Parameters** tabs and read the Power value for Port 2 (COM-RX), then continue with Step g.
- g. Verify that the value in Step e or f matches the power recorded in Step c, +/- 1.0 dB. If so, continue with [Step 19](#). If not, use the “[NTP-G115 Clean Fiber Connectors](#)” procedure on page 13-25 to clean the fiber connection between the OPT-BST-L or OSC-CSM and 32WSS-L cards. Check the values again. If they still do not match, contact your next level of support.

Step 19 If an OPT-AMP-L card provisioned in OPT-PRE mode is installed on the west side, complete the following steps. If not, continue with [Step 20](#).

- a. Display the west OPT-AMP-L card in card view.
- b. Click the **Provisioning > Optical Line > Parameters** tabs.
- c. Locate the Power parameter for Port 1 (COM-RX). Record the value.
- d. Display the west OPT-BST-L or OSC-CSM card in card view.
- e. Click the **Provisioning > Optical Line > Parameters** tabs.
- f. Locate the Port 2 (COM-TX) Power value (for OPT-BST-L cards) or Port 3 (COM-TX) Power value (for OSC-CSM card). Verify that the value matches the power recorded in Step c, +/- 1.5 dB. If not, use the “[NTP-G115 Clean Fiber Connectors](#)” procedure on page 13-25 to clean the fiber connection between the OPT-AMP-L card and the OPT-BST-L or OSC-CSM card. Check the values again. If they still do not match, contact your next level of support.
- g. For the west OPT-AMP-L card, complete the “[DLP-G80 Verify the OPT-PRE Amplifier Laser and Power](#)” task on page 4-6.

- Step 20** If an MMU card is installed on the west side, complete the following steps. If an MMU card is not installed on the west side, continue with [Step 21](#).
- a. Display the west MMU card in card view.
 - b. Click the **Provisioning > Optical Line > Parameters** tabs.
 - c. Locate the Port 68 (COM-RX) Power parameter. Record the value.
 - d. If an OPT-AMP-L card provisioned in OPT-PRE mode is installed on the west side, display it in card view and complete Step [e](#). If not, continue with Step [f](#).
 - e. Click the OPT-PRE **Provisioning > Opt.Ampli.Line > Parameters** tabs. Record the Total Output Power value for Port 2 (COM-TX), then continue with Step [i](#).
 - f. If an west OPT-BST-L card is installed, display it in card view and complete Step [g](#). If not, continue with Step [h](#).
 - g. Click the Provisioning > Optical Line > Parameters tabs and read the Power value for Port 2 (COM-TX), then continue with Step [i](#).
 - h. Display the west OSC-CSM card in card view, click the Provisioning > Optical Line > Parameters tabs and read the Power value for Port 3 (COM-TX), then continue with Step [i](#).
 - i. Verify that value in the Step [e](#), [g](#), or [h](#) matches the power recorded in Step [e](#), +/- 1.0 dB. If not, use the “[NTP-G115 Clean Fiber Connectors](#)” procedure on page 13-25 to clean the fiber connection between the MMU card and the OPT-BST-L or OSC-CSM cards. Check the values again. If they still do not match, contact your next level of support.
 - j. Display the west MMU card in card view.
 - k. Click the **Provisioning > Optical Line > Parameters** tabs.
 - l. Record the value in the Power table cell for Port 2 (EXP-TX).
 - m. Display the west 32WSS-L card in card view.
 - n. Click the **Provisioning > Optical Line > Parameters** tabs.
 - o. Verify that the value in the Power table cell for Port 68 (COM-RX) is equal to the value recorded in Step [l](#), +/- 1.0 dB. If not, use the “[NTP-G115 Clean Fiber Connectors](#)” procedure on page 13-25 to clean the fiber connection between the 32WSS-L and MMU cards. Check the values again. If they still do not match, contact your next level of support.
 - p. Continue with [Step 22](#).
- Step 21** Verify the connection between the west 32WSS-L card and the OPT-BST-L, OPT-AMP-L (in OPT-PRE mode), or OSC-CSM card:
- a. Display the west 32WSS-L in card view.
 - b. Click the **Provisioning > Optical Line > Parameters** tabs.
 - c. Locate the Port 68 (COM-RX) Power parameter. Record the value.
 - d. If an west OPT-AMP-L card provisioned in OPT-PRE mode is installed, display it in card view and complete Step [e](#). If not, continue with Step [f](#).
 - e. Click the **Provisioning > Opt.Ampli.Line > Parameters** tabs and read the Total Output Power value for Port 2 (COM-TX), then continue with Step [i](#).
 - f. If an west OPT-BST-L card is installed, display it in card view and complete Step [g](#). If not, continue with Step [h](#).
 - g. Click the **Provisioning > Optical Line > Parameters** tabs and read the Power value for Port 2 (COM-TX), then continue with Step [i](#).

- h. Display the west OSC-CSM card in card view. Click the **Provisioning > Optical Line > Parameters** tabs and read the Power value for Port 3 (COM-TX), then continue with Step i.
 - i. Verify that the value in Step e, g, or h matches the power recorded in Step c, +/- 1.5 dB. If not, use the “[NTP-G115 Clean Fiber Connectors](#)” procedure on page 13-25 to clean the fiber connection between the 32WSS-L card and the OPT-AMP-L, OPT-BST-L, or OSC-CSM card.
- Step 22** Verify the west 32WSS-L and 32DMX-L connection:
 - a. Display the west 32WSS-L card in card view.
 - b. Click the **Provisioning > Optical Line > Parameters** tabs, and record the value in the Power table cell for Port 69 (DROP-TX).
 - c. Display the west 32DMX-L card in card view.
 - d. Click the **Provisioning > Optical Line > Parameters** tabs. Record the value in the Port 2 (COM-RX) table cell. Verify that the value is equal to the value recorded in b., +/- 1 dBm. If not, use the “[NTP-G115 Clean Fiber Connectors](#)” procedure on page 13-25 to clean the fiber connection between the 32WSS-L and 32DMX-L cards. Check the values again. If they still do not match, contact your next level of support.
- Step 23** Display the west 32DMX-L card in card view.
- Step 24** Click the **Provisioning > Optical Chn > Parameters** tab. Record the CHAN-TX port value under the Power parameter for the wavelength under test.
- Step 25** Verify that the power value from Step 24 reaches the WestSide.Rx.Power.Add&Drop - Drop Power setpoint +/- 2 dBm. To view this setpoint:
 - a. Go to node view (single-shelf mode) or multishelf view (multishelf mode) and click the **Provisioning > WDM-ANS > Provisioning** tabs.
 - b. In the Selector window on the left, expand the **West Side** parameters tree view.
 - c. Expand the **RX** category.
 - d. Expand the **Power** category, then highlight **Add&Drop - Drop Power**.
 - e. View the WestSide.Rx.Power.Add&Drop - Drop Power parameter on the right pane.
 - f. If the power value does not match the value recorded in Step 24 (+/- 2 dBm), contact your next level of support.
- Step 26** Display the TXP_MR_10E_L card in card view.
- Step 27** Click the **Performance > Optics PM > Current Values** tabs.
- Step 28** In the Port 2 (Trunk) column, locate the RX Optical Power value. Verify that the value matches the power in Step 24, +/- 2 dBm. If the power values do not match (+/- 2 dBm), complete the following steps:
 - a. Remove, clean, and replace the cable connecting the TXP_MR_10E_C RX port to the west fiber patch panel DMX port for the tested wavelength. See the “[NTP-G115 Clean Fiber Connectors](#)” procedure on page 13-25.
 - b. Repeat this step. If the power values still do not match (+/- 2 dBm) contact your next level of support.
- Step 29** Repeat Steps 4 through 28 for the remaining wavelengths.
- Step 30** Display the west 32WSS-L card in card view.
- Step 31** Click the **Maintenance** tab.
- Step 32** Click the table cell under Operating Mode and choose **Not Assigned** from the drop-down list for all wavelengths.
- Step 33** Click **Apply**, then click **Yes** to confirm.

- Step 34** Disconnect the TXP or tunable laser from the west side patch panel.
- Step 35** Unplug the physical loopback fiber from the line TX and RX in the OPT-BST-L or OSC-CSM card.
- Step 36** Return to your originating procedure (NTP).

NTP-G44 Perform the Anti-ASE Hub Node Acceptance Test

Purpose	This procedure tests an anti-ASE hub node.
Tools/Equipment	A tunable laser or a TXP_MR_10E_C card An optical power meter or optical spectrum analyzer 2 bulk attenuators (10 dB) with LC connectors
Prerequisite Procedures	Chapter 3, “Turn Up a Node”
Required/As Needed	Required
Onsite/Remote	Onsite
Security Level	Superuser



Note Optical power measurements require either a tunable laser or a multirate transponder to generate the proper optical wavelength. If multirate transponders were installed during completion of [Chapter 3, “Turn Up a Node,”](#) they can be used for this procedure. No additional cabling changes are needed.

- Step 1** Complete the [“DLP-G46 Log into CTC” task on page 2-25](#) at the node where you want to perform the acceptance test. If you are already logged in, continue with [Step 2](#).
- Step 2** From the View menu, choose **Go to Network View**.
- Step 3** Click the **Alarms** tab.
- Verify that the alarm filter is not on. See the [“DLP-G128 Disable Alarm Filtering” task on page 8-28](#) as necessary.
 - Verify that no equipment alarms appear indicating equipment failure or other hardware problems. (Equipment alarms are indicated by an EQPT in the Alarms tab Cond column.) If alarms appear, investigate and resolve them before continuing. Refer to the *Cisco ONS 15454 DWDM Troubleshooting Guide* for procedures.



Note The OSC terminations created during node turn-up will generate two alarms for each side of the shelf: one for LOS on the OPT-BST or OPT-BST-E card, and the other for LOS on the OSC_CSM or OSCM card.

- Step 4** In node view (single-shelf mode) or multishelf view (multishelf mode), click the **Provisioning > WDM-ANS > Port Status** tabs. Verify that all statuses under Link Status are Success - Changed, Success - Unchanged, or Not Applicable. If any are not, complete the following steps:
- Delete the two OSC channels using the [“DLP-G186 Delete an OSC Termination” task on page 10-44](#).
 - Complete the [“NTP-G37 Run Automatic Node Setup” procedure on page 3-82](#).

- c. Create the OSC channels using the [“NTP-G38 Provision OSC Terminations” procedure on page 3-83](#).

Step 5 From your Cisco MetroPlanner site configuration file, identify the dropped and added channels that are configured in pass-through mode in both directions.



Note Configuring a channel pass-through mode means that the channel is dropped along one direction by a 32DMX-O or 32DMX (15xx.xx TX port) located on one side (west or east) of the shelf, and then added by a 32MUX-O/32DMX (1522.22 RX port) on the opposite side of the shelf but in the same direction. The channel is not terminated inside the site.

- Step 6** Create a loopback on the west OPT-BST or OPT-BST-E amplifier by connecting a patchcord from the LINE TX port to the LINE RX port with a 10-dB bulk attenuator.
- Step 7** Verify that the OSC link becomes active on the west OSCM or OSC-CSM card. (The OSC Termination must already be provisioned. If not, complete the [“NTP-G38 Provision OSC Terminations” procedure on page 3-83](#).)
- Step 8** For pass-through channels, continue with [Step 9](#). For add and drop channels, continue with [Step 18](#).
- Step 9** Verify the first channel connection configured in pass-through mode in both directions:
- a. If you are using a tunable laser, set the output power to a nominal value, such as -3 dBm. If you are using a TXP_MR_10E_C card, continue with [Step b](#).
 - b. Set the tunable laser or TXP_MR_10E_C card to a corresponding wavelength on the 100-GHz ITU-T grid. Refer to the tunable laser manufacturer’s documentation or the [“DLP-G268 Provision TXP_MR_10E_C Cards for Acceptance Testing” task on page 4-4](#).
 - c. Connect the tunable laser transmitter or the TXP_MR_10E_C card DWDM TX port to the LINE RX port of the east OPT-BST or OPT-BST-E using a 10-dB bulk attenuator.
- Step 10** Complete the [“DLP-G80 Verify the OPT-PRE Amplifier Laser and Power” task on page 4-6](#) for the east OPT-PRE amplifier.
- Step 11** Complete the [“DLP-G269 Verify the 32DMX-O Card Power” task on page 4-7](#) for the west 32MUX-O and 32DMX-O/32DMX cards.
- Step 12** Complete the [“DLP-G79 Verify the OPT-BST, OPT-BST-E, or OPT-BST-L Amplifier Laser and Power” task on page 4-5](#) for the west OPT-BST or OPT-BST-E amplifier.
- Step 13** Complete the [“DLP-G80 Verify the OPT-PRE Amplifier Laser and Power” task on page 4-6](#) for the west OPT-PRE amplifier.
- Step 14** Complete the [“DLP-G269 Verify the 32DMX-O Card Power” task on page 4-7](#) for the west 32MUX-O and 32DMX-O.32DMX cards.
- Step 15** Complete the [“DLP-G79 Verify the OPT-BST, OPT-BST-E, or OPT-BST-L Amplifier Laser and Power” task on page 4-5](#) for the east OPT-BST or OPT-BST-E amplifier.
- Step 16** Repeat [Steps 9](#) through [15](#) for the remaining wavelengths on the 100-GHz grid that are pass-through wavelengths.
- Step 17** If you have add and drop channels, continue with [Step 18](#) to verify the channels. If not, continue with [Step 29](#).
- Step 18** Set the tunable laser or TXP_MR_10E_C card to the first wavelength of the 100-GHz ITU-T grid that is not a pass-through wavelength. Refer to the tunable laser manufacturer’s documentation or the [“DLP-G268 Provision TXP_MR_10E_C Cards for Acceptance Testing” task on page 4-4](#).
- Step 19** Connect the tunable laser or TXP_MR_10E_C card to the CHAN RX *nn* port on the west 32MUX-O card, where *nn* is the first add or drop channel.

- Step 20** Display the west 32MUX-O in card view.
- Step 21** Click the **Provisioning > Optical Chn > Parameters** tabs.
- Step 22** Change the administrative state of Port *nn* to **OOS,MT** (ANSI) or **Locked,maintenance** (ETSI).
- Step 23** Check that the power value on Port *nn* reaches the provisioned setpoint (VOA Power Ref).
- Step 24** Display the west 32DMX-O card in card view.
- Step 25** Click the **Provisioning > Optical Chn > Parameters** tabs.
- Step 26** Change the administrative state of Port *nn* to **OOS,MT** (ANSI) or **Locked,maintenance** (ETSI).
- Step 27** Check that the power value on Port *nn* reaches the provisioned setpoint (VOA Power Ref).
- Step 28** (Optional) Connect a power meter to the CHAN TX *nn* port through the patch panel and verify that the physical optical power coming out of drop Port *nn* on the west 32DMX-O/32DMX card is consistent with the value read on the meter within 0.5 dB.
- Step 29** Repeat Steps 18 through 28 for the remaining wavelengths on the 100-GHz grid that are not pass-through wavelengths.
- Step 30** Remove the loopback connection on the west OPT-BST or OPT-BST-E card.
- Step 31** Complete the “[NTP-G37 Run Automatic Node Setup](#)” procedure on page 3-82 to restore the original configuration.
- Step 32** Create a loopback on the east OPT-BST or OPT-BST-E amplifier by connecting a patchcord from the LINE TX port to the LINE RX port with 10-dB bulk attenuator.
- Step 33** Verify that the OSC link becomes active on the east OSCM card. (The OSC termination must be already provisioned. If not, complete the “[NTP-G38 Provision OSC Terminations](#)” procedure on page 3-83.)
- Step 34** Repeat 18 through 33 for the east side add and drop cards.
- Step 35** Remove the loopback on the east OPT-BST or OPT-BST-E card.
- Step 36** Restore the default administrative state (IS,AINS/Unlocked,automaticInService) on all the ports previously set to **OOS,MT** (ANSI) or **Locked,maintenance** (ETSI).
- Stop. You have completed this procedure.**

NTP-G45 Perform the C-Band Line Amplifier Node with OSCM Cards Acceptance Test

Purpose	This procedure tests a C-band line amplifier node with OSCM cards installed on both the east and west sides of the shelf by looping a single wavelength through the shelf.
Tools/Equipment	One of the following: <ul style="list-style-type: none"> • A tunable laser • TXP_MR_10E_C An optical power meter or optical spectrum analyzer 2 bulk attenuators (10 dB) with LC connectors
Prerequisite Procedures	Chapter 3, “Turn Up a Node”

Required/As Needed	Required
Onsite/Remote	Onsite
Security Level	Superuser

**Note**

Optical power measurements require either a tunable laser or a multirate transponder to generate the proper optical wavelength. If multirate transponders were installed during completion of [Chapter 3, “Turn Up a Node,”](#) they can be used for this procedure. No additional cabling changes are needed.

-
- Step 1** Complete the [“DLP-G46 Log into CTC” task on page 2-25](#) at the node where you want to perform the acceptance test. If you are already logged in, continue with [Step 3](#).
- Step 2** If you are using TXP_MR_10E_C cards, complete the [“DLP-G268 Provision TXP_MR_10E_C Cards for Acceptance Testing” task on page 4-4](#). If not, continue with [Step 3](#).
- Step 3** From the View menu, choose **Go to Home View**.
- Step 4** Click the **Alarms** tab.
- Verify that the alarm filter is not on. See the [“DLP-G128 Disable Alarm Filtering” task on page 8-28](#) as necessary.
 - Verify that no equipment alarms appear indicating equipment failure or other hardware problems. (Equipment alarms are indicated by an EQPT in the Alarms tab Cond column.) If alarms appear, investigate and resolve them before continuing. Refer to the *Cisco ONS 15454 DWDM Troubleshooting Guide* for procedures.

**Note**

The OSC terminations created during node turn-up will generate two alarms for each side of the shelf, one for LOS on the OPT-BST or OPT-BST-E card, and the other for LOS on the OSCM card.

-
- Step 5** In node view (single-shelf mode) or multishelf view (multishelf mode), click the **Provisioning > WDM-ANS > Port Status** tabs. Verify that all statuses under Link Status are listed as Success - Changed, Success - Unchanged, or Not Applicable. If any are not, complete the following steps:
- Delete the two OSC channels using the [“DLP-G186 Delete an OSC Termination” task on page 10-44](#).
 - Complete the [“NTP-G37 Run Automatic Node Setup” procedure on page 3-82](#).
 - Create the OSC channels using the [“NTP-G38 Provision OSC Terminations” procedure on page 3-83](#).
- Step 6** Create a loopback on the west OPT-BST or OPT-BST-E card by using a fiber with a 10-dB bulk attenuator to connect the LINE TX port to the LINE RX port.
- Step 7** If you are using a tunable laser, follow the manufacturer’s instructions to complete the following steps. If you are using a TXP_MR_10E_C card, continue with [Step 8](#).
- Set the output power to a nominal value, such as -3 dBm.
 - Set the tuner to the wavelength under test, then continue with [Step 9](#).
- Step 8** If you are using a TXP_MR_10E_C card, complete the [“DLP-G268 Provision TXP_MR_10E_C Cards for Acceptance Testing” task on page 4-4](#) for the TXP containing the wavelength you will test. Refer to [Table 4-1 on page 4-21](#), if needed.
- Step 9** Connect the tunable laser transmitter or the TXP_MR_10E_C card DWDM TX port to the LINE RX port of the east OPT-BST or OPT-BST-E card using a 10-dB bulk attenuator.

**Caution**

Failure to use proper attenuation might damage equipment.

- Step 10** Wait 90 to 100 seconds, then in node view (single-shelf mode) or multishelf view (multishelf mode) click the **Alarms** tab. Verify that the LOS alarms on the west OPT-BST or OPT-BST-E and OSCM cards have cleared. The clearing of the LOS alarms indicates that the OSC link is active on the west side.

**Note**

An SDCC Termination Failure alarm will continue to appear due to the OSC signal loopback. An LOS-O alarm appears on the east OPT-BST or OPT-BST-E card, and an LOS alarm appears on the east OCSM card.

If the alarms clear, continue with [Step 11](#). If not, perform the following steps:

- a. Display the west OPT-BST or OPT-BST-E card in card view.
 - b. Click the **Provisioning > Optical Line > Optics Thresholds** tabs.
 - c. Under Types, click **Alarms**, then click **Refresh**.
 - d. Locate the Port 2 Power Failure Low parameter. Double-click the table cell and change the value to -30 dBm.
 - e. Locate the Port 4 Power Failure Low parameter. Double-click the table cell and change the value to -40 dBm.
 - f. Click **Apply**, and then **Yes**.
 - g. Wait 90 to 100 seconds, then in node view (single-shelf mode) or multishelf view (multishelf mode) click the **Alarms** tab. Verify that the LOS alarm on the west OPT-BST or OPT-BST-E card has cleared. If so, continue with [Step 11](#). If not, disconnect the OSCM card from the OPT-BST.
 - h. Create a loopback on the OSCM card by connecting a patch cable from the OSC TX port to the OSC RX port using a 10-dB bulk attenuator.
 - i. Wait 90 to 100 seconds, then in node view (single-shelf mode) or multishelf view (multishelf mode) click the **Alarms** tab. Verify that the LOS alarm on the west OSCM card has cleared. If so, replace the OPT-BST or OPT-BST-E card. If not, replace the OSCM card. See the “[NTP-G30 Install the DWDM Cards](#)” procedure on page 3-44.
- Step 11** If an OPT-PRE card is installed on the east side, complete the “[DLP-G80 Verify the OPT-PRE Amplifier Laser and Power](#)” task on page 4-6. If not, continue with [Step 12](#).
- Step 12** Complete the “[DLP-G79 Verify the OPT-BST, OPT-BST-E, or OPT-BST-L Amplifier Laser and Power](#)” task on page 4-5 for the west OPT-BST or OPT-BST-E amplifier.
- Step 13** If an OPT-PRE amplifier is installed on the west side, complete the “[DLP-G80 Verify the OPT-PRE Amplifier Laser and Power](#)” task on page 4-6. If not, continue with continue with [Step 14](#).
- Step 14** Complete the “[DLP-G79 Verify the OPT-BST, OPT-BST-E, or OPT-BST-L Amplifier Laser and Power](#)” task on page 4-5 for the east OPT-BST or OPT-BST-E amplifier.
- Step 15** Disconnect the TXP or tunable laser from the east OPT-BST or OPT-BST-E card.
- Step 16** Remove the loopback on the west OPT-BST or OPT-BST-E card created in [Step 6](#).
- Step 17** Create a loopback on the east OPT-BST or OPT-BST-E card by connecting a patchcord from the LINE TX port to the LINE RX port with a 10-dB bulk attenuator.
- Step 18** If you are using a tunable laser, follow the manufacturer’s instructions to complete the following steps. If you are using a TXP_MR_10E_C card, continue with [Step 19](#).
- a. Set the output power to a nominal value, such as -3 dBm.

b. Set the tuner to the wavelength under test, then continue with [Step 20](#).

Step 19 If you are using a TXP_MR_10E_C card, complete the “[DLP-G268 Provision TXP_MR_10E_C Cards for Acceptance Testing](#)” task on page 4-4 for the TXP containing the wavelength you will test. Refer to [Table 4-1](#) on page 4-21, if needed.

Step 20 Connect the tunable laser transmitter or the TXP_MR_10E_C card DWDM TX port to the LINE RX port of the west OPT-BST or OPT-BST-E card using a 10-dB bulk attenuator.



Caution Failure to use proper attenuation might damage equipment.

Step 21 Wait 90 to 100 seconds, then in node view (single-shelf mode) or multishelf view (multishelf mode) click the **Alarms** tab. Verify that the LOS alarms on the east OPT-BST or OPT-BST-E and OSCM cards have cleared. The clearing of the LOS alarms indicates that the OSC link is active on the east side.



Note An SDCC Termination Failure alarm will continue to appear due to the OSC signal loopback. An LOS-O alarm appears on the west OPT-BST or OPT-BST-E card, and an LOS alarm appears on the west OSCM card.

If the alarms clear, continue with [Step 22](#). If not, perform the following steps:

- a. Display the east OPT-BST or OPT-BST-E card in card view.
- b. Click the **Provisioning > Optical Line > Optics Thresholds** tabs.
- c. Under Types, click **Alarms**, then click **Refresh**.
- d. Locate the Port 2 Power Failure Low parameter. Double-click the table cell and change the value to -30 dBm.
- e. Locate the Port 4 Power Failure Low parameter. Double-click the table cell and change the value to -40 dBm.
- f. Click **Apply**, and then **Yes**.
- g. Wait 90 to 100 seconds, then in node view (single-shelf mode) or multishelf view (multishelf mode) click the **Alarms** tab. Verify that the LOS alarms on the east OPT-BST or OPT-BST-E card has cleared. If so, continue with [Step 22](#). If not, disconnect the OSCM card from the OPT-BST or OPT-BST-E card.
- h. Create a loopback on the OSCM card by connecting a patch cable from the OSC TX port to the OSC RX port using a 10-dB bulk attenuator.
- i. Wait 90 to 100 seconds, then in node view (single-shelf mode) or multishelf view (multishelf mode) click the **Alarms** tab. Verify that the LOS alarms on the east OSCM card has cleared. If so, replace the OPT-BST or OPT-BST-E card. If not, replace the OSCM card. See the “[NTP-G30 Install the DWDM Cards](#)” procedure on page 3-44.

Step 22 If an OPT-PRE card is installed on the west side, complete the “[DLP-G80 Verify the OPT-PRE Amplifier Laser and Power](#)” task on page 4-6. If not, continue with [Step 23](#).

Step 23 Complete the “[DLP-G79 Verify the OPT-BST, OPT-BST-E, or OPT-BST-L Amplifier Laser and Power](#)” task on page 4-5 for the east OPT-BST or OPT-BST-E amplifier.

Step 24 If an OPT-PRE amplifier is installed on the east side, complete the “[DLP-G80 Verify the OPT-PRE Amplifier Laser and Power](#)” task on page 4-6. If not, continue with continue with [Step 25](#).

Step 25 Complete the “[DLP-G79 Verify the OPT-BST, OPT-BST-E, or OPT-BST-L Amplifier Laser and Power](#)” task on page 4-5 for the west OPT-BST or OPT-BST-E amplifier.

- Step 26** Disconnect the TXP or tunable laser from the west OPT-BST or OPT-BST-E card.
- Step 27** Remove the loopback on the east OPT-BST or OPT-BST-E amplifier created in [Step 17](#).
- Step 28** Delete both OSC channels using the “[DLP-G186 Delete an OSC Termination](#)” task on page 10-44.
- Step 29** Complete the “[NTP-G37 Run Automatic Node Setup](#)” procedure on page 3-82 to restore the original configuration.
- Step 30** Create the two OSC channels using the “[NTP-G38 Provision OSC Terminations](#)” procedure on page 3-83.
- Stop.** You have completed this procedure.

NTP-G155 Perform the L-Band Line Amplifier Node with OSCM Cards Acceptance Test

Purpose	This procedure tests a L-band line amplifier node with OSCM cards installed on both the east and west sides of the shelf by looping a single wavelength through the shelf.
Tools/Equipment	One of the following: <ul style="list-style-type: none"> • A tunable laser • TXP_MR_10E_L An optical power meter or optical spectrum analyzer 2 bulk attenuators (10 dB) with LC connectors
Prerequisite Procedures	Chapter 3, “Turn Up a Node”
Required/As Needed	Required
Onsite/Remote	Onsite
Security Level	Superuser



Note Optical power measurements require either a tunable laser or a multirate transponder to generate the proper optical wavelength. If multirate transponders were installed during completion of [Chapter 3, “Turn Up a Node,”](#) they can be used for this procedure. No additional cabling changes are needed.

- Step 1** Complete the “[DLP-G46 Log into CTC](#)” task on page 2-25 at the node where you want to perform the acceptance test. If you are already logged in, continue with [Step 3](#).
- Step 2** If you are using TXP_MR_10E_L cards, complete the “[DLP-G358 Provision TXP_MR_10E_L Card for Acceptance Testing](#)” task on page 4-16. If not, continue with [Step 3](#).
- Step 3** From the View menu, choose **Go to Home View**.
- Step 4** Click the **Alarms** tab.
- Verify that the alarm filter is not on. See the “[DLP-G128 Disable Alarm Filtering](#)” task on page 8-28 as necessary.

- b. Verify that no equipment alarms appear indicating equipment failure or other hardware problems. (Equipment alarms are indicated by an EQPT in the Alarms tab Cond column.) If alarms appear, investigate and resolve them before continuing. Refer to the *Cisco ONS 15454 DWDM Troubleshooting Guide* for procedures.



Note The OSC terminations created during node turn-up will generate two alarms for each side of the shelf, one for an LOS on the OPT-BST-L card, and the other for an LOS on the OSCM card.

- Step 5** In node view (single-shelf mode) or multishelf view (multishelf mode), click the **Provisioning > WDM-ANS > Port Status** tabs. Verify that all statuses under Link Status are listed as Success - Changed, Success - Unchanged, or Not Applicable. If any are not, complete the following steps:
- a. Delete the two OSC channels using the “[DLP-G186 Delete an OSC Termination](#)” task on [page 10-44](#).
 - b. Complete the “[NTP-G37 Run Automatic Node Setup](#)” procedure on [page 3-82](#).
 - c. Create the OSC channels using the “[NTP-G38 Provision OSC Terminations](#)” procedure on [page 3-83](#).
- Step 6** Create a loopback on the west OPT-BST-L card by using a fiber with a 10-dB bulk attenuator to connect the LINE TX port to the LINE RX port.
- Step 7** If you are using a tunable laser, follow the manufacturer’s instructions to complete the following steps. If you are using a TXP_MR_10E_L card, continue with [Step 8](#).
- a. Set the output power to a nominal value, such as –3 dBm.
 - b. Set the tuner to the wavelength under test, then continue with [Step 9](#).
- Step 8** If you are using a TXP_MR_10E_L card, complete the “[DLP-G358 Provision TXP_MR_10E_L Card for Acceptance Testing](#)” task on [page 4-16](#) for the wavelength you will test.
- Step 9** Connect the tunable laser transmitter or the TXP_MR_10E_L card DWDM TX port to the LINE RX port of the east OPT-BST-L card using a 10-dB bulk attenuator.



Caution Failure to use proper attenuation might damage equipment.

- Step 10** Wait 90 to 100 seconds, then in node view (single-shelf mode) or multishelf view (multishelf mode) click the **Alarms** tab. Verify that the LOS alarms on the west OPT-BST-L and OSCM cards have cleared. The clearing of the LOS alarms indicates that the OSC link is active on the west side.



Note An SDCC Termination Failure alarm will continue to appear due to the OSC signal loopback. An LOS-O alarm appears on the east OPT-BST-L card, and an LOS alarm appears on the east OSCM card.

If the alarms clear, continue with [Step 11](#). If not, perform the following steps:

- a. Display the west OPT-BST-L card in card view.
- b. Click the **Provisioning > Optical Line > Optics Thresholds** tabs.
- c. Under Types, click **Alarms**, then click **Refresh**.
- d. Locate the Port 2 Power Failure Low parameter. Double-click the table cell and change the value to –30 dBm.

- e. Locate the Port 4 Power Failure Low parameter. Double-click the table cell and change the value to -40 dBm.
- f. Click **Apply**, and then **Yes**.
- g. Wait 90 to 100 seconds, then in node view (single-shelf mode) or multishelf view (multishelf mode) click the **Alarms** tab. Verify that the LOS alarm on the west OPT-BST-L card has cleared. If so, continue with [Step 11](#). If not, disconnect the OSCM card from the OPT-BST-L card.
- h. Create a loopback on the OSCM card by connecting a patch cable from the OSC TX port to the OSC RX port using a 10-dB bulk attenuator.
- i. Wait 90 to 100 seconds, then in node view (single-shelf mode) or multishelf view (multishelf mode) click the **Alarms** tab. Verify that the LOS alarm on the west OSCM card has cleared. If so, replace the OPT-BST-L card. If not, replace the OSCM card. See the “[NTP-G30 Install the DWDM Cards](#)” procedure on page 3-44.

- Step 11** If an OPT-AMP-L card (provisioned as an OPT-PRE) is installed on the east side, complete the “[DLP-G360 Verify the OPT-AMP-L \(OPT-PRE Mode\) Amplifier Laser and Power](#)” task on page 4-18. If not, continue with [Step 12](#).
- Step 12** Complete the “[DLP-G359 Verify the OPT-BST-L or OPT-AMP-L \(OPT-Line Mode\) Amplifier Laser and Power](#)” task on page 4-17 for the west OPT-BST-L amplifier.
- Step 13** If an OPT-AMP-L card (provisioned as an OPT-PRE) is installed on the west side, complete the “[DLP-G360 Verify the OPT-AMP-L \(OPT-PRE Mode\) Amplifier Laser and Power](#)” task on page 4-18. If not, continue with [Step 14](#).
- Step 14** Complete the “[DLP-G359 Verify the OPT-BST-L or OPT-AMP-L \(OPT-Line Mode\) Amplifier Laser and Power](#)” task on page 4-17 for the east OPT-BST-L amplifier.
- Step 15** Disconnect the TXP card or tunable laser from the east OPT-BST-L card.
- Step 16** Remove the loopback on the west OPT-BST-L created in [Step 6](#).
- Step 17** Create a loopback on the east OPT-BST-L card by connecting a patchcord from the LINE TX port to the LINE RX port with a 10-dB bulk attenuator.
- Step 18** If you are using a tunable laser, follow the manufacturer’s instructions to complete the following steps. If you are using a TXP_MR_10E_L card, continue with [Step 19](#).
- a. Set the output power to a nominal value, such as -3 dBm.
 - b. Set the tuner to the wavelength under test, then continue with [Step 20](#).
- Step 19** If you are using a TXP_MR_10E_L card, complete the “[DLP-G358 Provision TXP_MR_10E_L Card for Acceptance Testing](#)” task on page 4-16 for the wavelength you will test.
- Step 20** Connect the tunable laser transmitter or the TXP_MR_10E_L card DWDM TX port to the LINE RX port of the west OPT-BST-L card using a 10-dB bulk attenuator.



Caution Failure to use proper attenuation might damage equipment.

- Step 21** Wait 90 to 100 seconds, then in node view (single-shelf mode) or multishelf view (multishelf mode) click the **Alarms** tab. Verify that the LOS alarms on the east OPT-BST-L and OSCM cards have cleared. The clearing of the LOS alarms indicates that the OSC link is active on the east side.



Note An SDCC Termination Failure alarm will continue to appear due to the OSC signal loopback. An LOS-O alarm appears on the west OPT-BST-L card, and an LOS alarm appears on the west OSCM card.

If the alarms clear, continue with [Step 22](#). If not, perform the following steps:

- a. Display the east OPT-BST-L card in card view.
- b. Click the **Provisioning > Optical Line > Optics Thresholds** tabs.
- c. Under Types, click **Alarms**, then click **Refresh**.
- d. Locate the Port 2 Power Failure Low parameter. Double-click the table cell and change the value to -30 dBm.
- e. Locate the Port 4 Power Failure Low parameter. Double-click the table cell and change the value to -40 dBm.
- f. Click **Apply**, and then **Yes**.
- g. Wait 90 to 100 seconds, then in node view (single-shelf mode) or multishelf view (multishelf mode) click the **Alarms** tab. Verify that the LOS alarms on the east OPT-BST-L card has cleared. If so, continue with [Step 22](#). If not, disconnect the OSCM card from the OPT-BST-L card.
- h. Create a loopback on the OSCM card by connecting a patch cable from the OSC TX port to the OSC RX port using a 10-dB bulk attenuator.
- i. Wait 90 to 100 seconds, then in node view (single-shelf mode) or multishelf view (multishelf mode) click the **Alarms** tab. Verify that the LOS alarms on the east OSCM card has cleared. If so, replace the OPT-BST-L card. If not, replace the OSCM card. See the “[NTP-G30 Install the DWDM Cards](#)” procedure on page 3-44.

- Step 22** If an OPT-AMP-L (provisioned in OPT-PRE mode) card is installed on the west side, complete the “[DLP-G80 Verify the OPT-PRE Amplifier Laser and Power](#)” task on page 4-6. If not, continue with [Step 23](#).
- Step 23** Complete the “[DLP-G359 Verify the OPT-BST-L or OPT-AMP-L \(OPT-Line Mode\) Amplifier Laser and Power](#)” task on page 4-17 for the east OPT-BST-L amplifier.
- Step 24** If an OPT-AMP-L (provisioned in OPT-PRE mode) card is installed on the east side, complete the “[DLP-G360 Verify the OPT-AMP-L \(OPT-PRE Mode\) Amplifier Laser and Power](#)” task on page 4-18. If not, continue with [Step 25](#).
- Step 25** Complete the “[DLP-G359 Verify the OPT-BST-L or OPT-AMP-L \(OPT-Line Mode\) Amplifier Laser and Power](#)” task on page 4-17 for the west OPT-BST-L amplifier.
- Step 26** Disconnect the TXP card or tunable laser from the west OPT-BST-L card.
- Step 27** Remove the loopback on the east OPT-BST-L amplifier created in [Step 17](#).
- Step 28** Delete both OSC channels using the “[DLP-G186 Delete an OSC Termination](#)” task on page 10-44.
- Step 29** Complete the “[NTP-G37 Run Automatic Node Setup](#)” procedure on page 3-82 to restore the original configuration.
- Step 30** Create the two OSC channels using the “[NTP-G38 Provision OSC Terminations](#)” procedure on page 3-83.

Stop. You have completed this procedure.

NTP-G46 Perform the C-Band Line Amplifier Node with OSC-CSM Cards Acceptance Test

Purpose	This procedure tests a C-band line amplifier node with OSC-CSM cards installed on both the east and west sides of the shelf by looping a single wavelength through the shelf.
Tools/Equipment	One of the following: <ul style="list-style-type: none"> • A tunable laser • TXP_MR_10E_C card An optical power meter or optical spectrum analyzer 2 bulk attenuators (10 dB) with LC connectors
Prerequisite Procedures	Chapter 3, “Turn Up a Node”
Required/As Needed	Required
Onsite/Remote	Onsite
Security Level	Superuser

Note

Optical power measurements require either a tunable laser or a multirate transponder to generate the proper optical wavelength. If multirate transponders were installed during completion of [Chapter 3, “Turn Up a Node,”](#) they can be used for this procedure. No additional cabling changes are needed.

-
- Step 1** Complete the [“DLP-G46 Log into CTC” task on page 2-25](#) at the node where you want to perform the acceptance test. If you are already logged in, continue with [Step 3](#).
- Step 2** If you are using TXP_MR_10E_C cards, complete the [“DLP-G268 Provision TXP_MR_10E_C Cards for Acceptance Testing” task on page 4-4](#). If not, continue with [Step 3](#).
- Step 3** From the View menu, choose **Go to Home View**.
- Step 4** Click the **Alarms** tab.
- Verify that the alarm filter is not on. See the [“DLP-G128 Disable Alarm Filtering” task on page 8-28](#) as necessary.
 - Verify that no equipment alarms appear indicating equipment failure or other hardware problems. (Equipment alarms are indicated by an EQPT in the Alarms tab Cond column.) If alarms appear, investigate and resolve them before continuing. Refer to the *Cisco ONS 15454 DWDM Troubleshooting Guide* for procedures.

Note

The OSC terminations created during node turn-up will generate an LOS alarm on the OSC-CSM card.

- Step 5** In node view (single-shelf mode) or multishelf view (multishelf mode), click the **Provisioning > WDM-ANS > Port Status** tabs. Verify that all statuses under Link Status are listed as Success - Changed, Success - Unchanged, or Not Applicable. If any are not, complete the following:
- Delete the two OSC channels using the [“DLP-G186 Delete an OSC Termination” task on page 10-44](#).
 - Complete the [“NTP-G37 Run Automatic Node Setup” procedure on page 3-82](#).

- c. Create the OSC channels using the “[NTP-G38 Provision OSC Terminations](#)” procedure on page 3-83.

Step 6 Create a physical loopback on the west OSC-CSM card by connecting the LINE TX port to the LINE RX port with a fiber and 10-dB bulk attenuator.



Caution Failure to use proper attenuation might damage equipment.

Step 7 Wait 90 to 100 seconds, then in node view (single-shelf mode) or multishelf view (multishelf mode) click the **Alarms** tab. Verify that the LOS alarm on the west OSC-CSM card has cleared. The clearing of the LOS alarm indicates that the OSC link is active on the west side.



Note An SDCC Termination Failure alarm will continue to appear due to the OSC signal loopback, and an LOS alarm will appear for the east OSC-CSM, Port 1 (OSC).

If the alarm clears, continue with [Step 8](#). If not, perform the following steps:

- a. Remove the 10-dB bulk attenuator on the OSC-CSM LINE TX and LINE RX ports and reconnect using only the patchcord.
- b. In node view (single-shelf mode) or multishelf view (multishelf mode), click the **Alarms** tab. If the LOS alarm on the west OSC-CSM card clears, continue with [Step 8](#). If not, continue with [Step c](#).
- c. Display the OSC-CSM card in card view.
- d. Click the **Provisioning > Optical Line > Optics Thresholds** tabs.
- e. Under Types, click **Alarm**, then click **Refresh**.
- f. Locate the Port 3 Power Failure Low parameter. Double-click the table cell and change the value to -30 dBm.
- g. Locate the Port 6 Power Failure Low parameter. Double-click the table cell and change the value to -40 dBm.
- h. Click **Apply**, and then **Yes**.
- i. In node view (single-shelf mode) or multishelf view (multishelf mode), click the **Alarms** tab. If the LOS alarm on the west OSC-CSM card clears, continue with [Step 8](#). If not, replace the OSC-CSM card.

Step 8 If you are using a tunable laser, follow the manufacturer’s instructions to complete the following steps. If you are using a TXP_MR_10E_C card, continue with [Step 9](#).

- a. Set the output power to a nominal value, such as -3 dBm.
- b. Set the tuner to the wavelength under test, then continue with [Step 10](#).

Step 9 If you are using a TXP_MR_10E_C card, complete the “[DLP-G268 Provision TXP_MR_10E_C Cards for Acceptance Testing](#)” task on page 4-4 for the TXP containing the wavelength you will test. Refer to [Table 4-1](#) on page 4-21, if needed.

Step 10 Connect the tunable laser transmitter or the TXP_MR_10E_C card DWDM TX port to the east OSC-CSM LINE RX port using a 10-dB bulk attenuator.



Caution Failure to use proper attenuation might damage equipment.

- Step 11** If an OPT-PRE card is installed on the east side, complete the “[DLP-G80 Verify the OPT-PRE Amplifier Laser and Power](#)” task on page 4-6. If not, continue with [Step 12](#).
- Step 12** Display the west OSC-CSM card in card view.
- Step 13** Click the **Provisioning > Optical Line > Parameters** tabs. Locate the Port 3 Power value. Verify that the value is higher than –30 dBm. If the power value is not higher than –30 dBm, check your connections and clean the fibers using the “[NTP-G115 Clean Fiber Connectors](#)” procedure on page 13-25. If this does not change the power value, consult your next level of support.
- Step 14** If an OPT-PRE card is installed on the west side of the shelf, complete the “[DLP-G80 Verify the OPT-PRE Amplifier Laser and Power](#)” task on page 4-6. If not, continue with [Step 15](#).
- Step 15** Display the east OSC-CSM card in card view.
- Step 16** Click the **Provisioning > Optical Line > Parameters** tabs. Locate the Port 2 Power value. Verify that the value is higher than –30 dBm. If the power value is not higher than –30 dBm, check your connections and clean the fibers using the “[NTP-G115 Clean Fiber Connectors](#)” procedure on page 13-25. If this does not change the power value, consult your next level of support.
- Step 17** Disconnect the TXP or tunable laser from the east OSC-CSM card.
- Step 18** Remove the physical loopback created on the west OSC-CSM card in [Step 6](#).
- Step 19** Create a loopback on the east OSC-CSM card by connecting the LINE TX port with LINE RX port using a patchcord and 10-dB bulk attenuator.

**Caution**

Failure to use proper attenuation might damage equipment.

- Step 20** Wait 90 to 100 seconds, then in node view (single-shelf mode) or multishelf view (multishelf mode) click the **Alarms** tab. Verify that the LOS alarm on the east OSC-CSM card has cleared. The clearing of the LOS alarm indicates that the OSC link is active on the east side.

**Note**

An SDCC Termination Failure alarm will continue to appear due to the OSC signal loopback, and an LOS alarm will appear for the west OSC-CSM, Port 1 (OSC).

If the alarm clears, continue with [Step 21](#). If not, perform the following steps:

- a. Remove the 10-dB bulk attenuator on the OSC-CSM LINE TX and LINE RX ports and reconnect using only the patchcord.
- b. Wait 90 to 100 seconds then, in node view (single-shelf mode) or multishelf view (multishelf mode), click the **Alarms** tab. If the LOS alarm on the east OSC-CSM card clears, continue with [Step 21](#). If not, continue with [Step c](#).
- c. Display the OSC-CSM card in card view.
- d. Click the **Provisioning > Optical Line > Optics Thresholds** tabs.
- e. Under Types, click **Alarm**, then click **Refresh**.
- f. Locate the Port 3 Power Failure Low parameter. Double-click the table cell and change the value to –30 dBm.
- g. Locate the Port 6 Power Failure Low parameter. Double-click the table cell and change the value to –40 dBm.
- h. Click **Apply**, and then **Yes**.

- i. In node view (single-shelf mode) or multishelf view (multishelf mode), click the **Alarms** tab. If the LOS alarm on the east OSC-CSM card clears, continue with [Step 21](#). If not, replace the OSC-CSM card.
- Step 21** If you are using a tunable laser, follow the manufacturer's instructions to complete the following steps. If you are using a TXP_MR_10E_C card, continue with [Step 22](#).
- a. Set the output power to a nominal value, such as -3 dBm.
 - b. Set the tuner to the wavelength under test, then continue with [Step 23](#).
- Step 22** If you are using a TXP_MR_10E_C card, complete the “[DLP-G268 Provision TXP_MR_10E_C Cards for Acceptance Testing](#)” task on page 4-4 for the TXP containing the wavelength you will test. Refer to [Table 4-1](#) on page 4-21, if needed.
- Step 23** Connect the tunable laser transmitter or the TXP_MR_10E_C card DWDM TX port to the west OSC-CSM LINE RX port using a 10-dB bulk attenuator.

**Caution**

Failure to use proper attenuation might damage equipment.

- Step 24** If an OPT-PRE card is installed on the west side, complete the “[DLP-G80 Verify the OPT-PRE Amplifier Laser and Power](#)” task on page 4-6. If not, continue with [Step 25](#).
- Step 25** Display the east OSC-CSM card in card view.
- Step 26** Click the **Provisioning > Optical Line > Parameters** tabs. Locate the Port 3 Power value. Verify that the value is higher than -30 dBm. If the power value is not higher than -30 dBm, check your connections and clean the fibers using the “[NTP-G115 Clean Fiber Connectors](#)” procedure on page 13-25. If this does not change the power value, consult your next level of support.
- Step 27** If an OPT-PRE is installed on the east side of the shelf, complete the “[DLP-G80 Verify the OPT-PRE Amplifier Laser and Power](#)” task on page 4-6 for the east OPT-PRE amplifier. If not, continue with [Step 28](#).
- Step 28** Display the west OSC-CSM card in card view.
- Step 29** Click the **Provisioning > Optical Line > Parameters** tabs and locate the Power value for Port 2. Verify that the value is higher than -30 dBm. If the power value is not higher than -30 dBm, check your connections and clean the fibers using the “[NTP-G115 Clean Fiber Connectors](#)” procedure on page 13-25. If this does not change the power value, consult your next level of support.
- Step 30** Disconnect the TXP card or tunable laser from the west OSC-CSM card.
- Step 31** Remove the loopback created on the east OSC-CSM card in [Step 19](#).
- Step 32** Delete both OSC channels. See the “[DLP-G186 Delete an OSC Termination](#)” task on page 10-44.
- Step 33** Complete the “[NTP-G37 Run Automatic Node Setup](#)” procedure on page 3-82 to restore the original configuration.
- Step 34** Create the OSC channels using the “[NTP-G38 Provision OSC Terminations](#)” procedure on page 3-83.
- Stop. You have completed this procedure.**

NTP-G156 Perform the L-Band Line Amplifier Node with OSC-CSM Cards Acceptance Test

Purpose	This procedure tests a L-band line amplifier node with OSC-CSM cards installed on both the east and west sides of the shelf by looping a single wavelength through the shelf.
Tools/Equipment	One of the following: <ul style="list-style-type: none"> • A tunable laser • TXP_MR_10E_L card An optical power meter or optical spectrum analyzer 2 bulk attenuators (10 dB) with LC connectors
Prerequisite Procedures	Chapter 3, “Turn Up a Node”
Required/As Needed	Required
Onsite/Remote	Onsite
Security Level	Superuser

Note

Optical power measurements require either a tunable laser or a multirate transponder to generate the proper optical wavelength. If multirate transponders were installed during completion of [Chapter 3, “Turn Up a Node,”](#) they can be used for this procedure. No additional cabling changes are needed.

-
- Step 1** Complete the [“DLP-G46 Log into CTC” task on page 2-25](#) at the node where you want to perform the acceptance test. If you are already logged in, continue with [Step 3](#).
- Step 2** If you are using TXP_MR_10E_L cards, complete the [“DLP-G358 Provision TXP_MR_10E_L Card for Acceptance Testing” task on page 4-16](#). If not, continue with [Step 3](#).
- Step 3** From the View menu, choose **Go to Home View**.
- Step 4** Click the **Alarms** tab.
- Verify that the alarm filter is not on. See the [“DLP-G128 Disable Alarm Filtering” task on page 8-28](#) as necessary.
 - Verify that no equipment alarms appear indicating equipment failure or other hardware problems. (Equipment alarms are indicated by an EQPT in the Alarms tab Cond column.) If alarms appear, investigate and resolve them before continuing. Refer to the *Cisco ONS 15454 DWDM Troubleshooting Guide* for procedures.

Note

The OSC terminations created during node turn-up will generate an LOS alarm on the OSC-CSM card.

- Step 5** In node view (single-shelf mode) or multishelf view (multishelf mode), click the **Provisioning > WDM-ANS > Port Status** tabs. Verify that all statuses under Link Status are listed as Success - Changed, Success - Unchanged, or Not Applicable. If any are not, complete the following:
- Delete the two OSC channels using the [“DLP-G186 Delete an OSC Termination” task on page 10-44](#).
 - Complete the [“NTP-G37 Run Automatic Node Setup” procedure on page 3-82](#).

- c. Create the OSC channels using the “[NTP-G38 Provision OSC Terminations](#)” procedure on page 3-83.

Step 6 Create a physical loopback on the west OSC-CSM by connecting the LINE TX port to the LINE RX port with a fiber and 10-dB bulk attenuator.



Caution Failure to use proper attenuation might damage equipment.

Step 7 Wait 90 to 100 seconds, then in node view (single-shelf mode) or multishelf view (multishelf mode) click the **Alarms** tab. Verify that the LOS alarm on the west OSC-CSM card has cleared. The clearing of the LOS alarm indicates that the OSC link is active on the west side.



Note An SDCC Termination Failure alarm will continue to appear due to the OSC signal loopback, and an LOS alarm will appear for the east OSC-CSM, Port 1 (OSC).

If the alarm clears, continue with [Step 8](#). If not, perform the following steps:

- a. Remove the 10-dB bulk attenuator on the OSC-CSM LINE TX and LINE RX ports and reconnect using only the patchcord.
- b. In node view (single-shelf mode) or multishelf view (multishelf mode), click the **Alarms** tab. If the LOS alarm on the west OSC-CSM card clears, continue with [Step 8](#). If not, continue with [Step c](#).
- c. Display the OSC-CSM card in card view.
- d. Click the **Provisioning > Optical Line > Optics Thresholds** tabs.
- e. Under Types, click **Alarm**, then click **Refresh**.
- f. Locate the Port 3 Power Failure Low parameter. Double-click the table cell and change the value to -30 dBm.
- g. Locate the Port 6 Power Failure Low parameter. Double-click the table cell and change the value to -40 dBm.
- h. Click **Apply**, and then **Yes**.
- i. In node view (single-shelf mode) or multishelf view (multishelf mode), click the **Alarms** tab. If the LOS alarm on the west OSC-CSM card clears, continue with [Step 8](#). If not, replace the OSC-CSM card.

Step 8 If you are using a tunable laser, follow the manufacturer’s instructions to complete the following steps. If you are using a TXP_MR_10E_L card, continue with [Step 9](#).

- a. Set the output power to a nominal value, such as -3 dBm.
- b. Set the tuner to the wavelength under test, then continue with [Step 10](#).

Step 9 If you are using a TXP_MR_10E_L card, complete the “[DLP-G358 Provision TXP_MR_10E_L Card for Acceptance Testing](#)” task on page 4-16 for the wavelength you will test.

Step 10 Connect the tunable laser transmitter or the TXP_MR_10E_L card DWDM TX port to the east OSC-CSM LINE RX port using a 10-dB bulk attenuator.



Caution Failure to use proper attenuation might damage equipment.

- Step 11** If an OPT-AMP-L card (provisioned in OPT-PRE mode) is installed on the east side, complete the “DLP-G360 Verify the OPT-AMP-L (OPT-PRE Mode) Amplifier Laser and Power” task on page 4-18. If not, continue with [Step 12](#).
- Step 12** Display the west OSC-CSM card in card view.
- Step 13** Click the **Provisioning > Optical Line > Parameters** tabs. Locate the Port 3 Power value. Verify that the value is higher than –30 dBm. If the power value is not higher than –30 dBm, check your connections and clean the fibers using the “NTP-G115 Clean Fiber Connectors” procedure on page 13-25. If this does not change the power value, consult your next level of support.
- Step 14** If an OPT-AMP-L card (provisioned in OPT-PRE mode) is installed on the west side of the shelf, complete the “DLP-G360 Verify the OPT-AMP-L (OPT-PRE Mode) Amplifier Laser and Power” task on page 4-18. If not, continue with [Step 15](#).
- Step 15** Display the east OSC-CSM card in card view.
- Step 16** Click the **Provisioning > Optical Line > Parameters** tabs. Locate the Port 2 Power value. Verify that the value is higher than –30 dBm. If the power value is not higher than –30 dBm, check your connections and clean the fibers using the “NTP-G115 Clean Fiber Connectors” procedure on page 13-25. If this does not change the power value, consult your next level of support.
- Step 17** Disconnect the TXP card or tunable laser from the east OSC-CSM card.
- Step 18** Remove the physical loopback created on the west OSC-CSM card in [Step 6](#).
- Step 19** Create a loopback on the east OSC-CSM by connecting the LINE TX port with LINE RX port using a patchcord and 10-dB bulk attenuator.



Caution Failure to use proper attenuation might damage equipment.

- Step 20** Wait 90 to 100 seconds, then in node view (single-shelf mode) or multishelf view (multishelf mode) click the **Alarms** tab. Verify that the LOS alarm on the east OSC-CSM card has cleared. The clearing of the LOS alarm indicates that the OSC link is active on the east side.



Note An SDCC Termination Failure alarm will continue to appear due to the OSC signal loopback, and an LOS alarm will appear for the west OSC-CSM, Port 1 (OSC).

If the alarm clears, continue with [Step 21](#). If not, perform the following steps:

- a. Remove the 10-dB bulk attenuator on the OSC-CSM LINE TX and LINE RX ports and reconnect using only the patchcord.
- b. Wait 90 to 100 seconds then, in node view (single-shelf mode) or multishelf view (multishelf mode), click the **Alarms** tab. If the LOS alarm on the east OSC-CSM card clears, continue with [Step 21](#). If not, continue with [Step c](#).
- c. Display the OSC-CSM card in card view.
- d. Click the **Provisioning > Optical Line > Optics Thresholds** tabs.
- e. Under Types, click **Alarm**, then click **Refresh**.
- f. Locate the Port 3 Power Failure Low parameter. Double-click the table cell and change the value to –30 dBm.
- g. Locate the Port 6 Power Failure Low parameter. Double-click the table cell and change the value to –40 dBm.
- h. Click **Apply**, and then **Yes**.

- i. In node view (single-shelf mode) or multishelf view (multishelf mode), click the **Alarms** tab. If the LOS alarm on the east OSC-CSM card clears, continue with [Step 21](#). If not, replace the OSC-CSM card.
- Step 21** If you are using a tunable laser, follow the manufacturer's instructions to complete the following steps. If you are using a TXP_MR_10E_L card, continue with [Step 22](#).
- a. Set the output power to a nominal value, such as -3 dBm.
 - b. Set the tuner to the wavelength under test, then continue with [Step 23](#).
- Step 22** If you are using a TXP_MR_10E_L card, complete the “[DLP-G358 Provision TXP_MR_10E_L Card for Acceptance Testing](#)” task on page 4-16 for the wavelength you will test.
- Step 23** Connect the tunable laser transmitter or the TXP_MR_10E_L card DWDM TX port to the west OSC-CSM LINE RX port using a 10-dB bulk attenuator.



Caution Failure to use proper attenuation might damage equipment.

- Step 24** If an OPT-AMP-L card (provisioned in OPT-PRE mode) is installed on the west side, complete the “[DLP-G360 Verify the OPT-AMP-L \(OPT-PRE Mode\) Amplifier Laser and Power](#)” task on page 4-18. If not, continue with [Step 25](#).
- Step 25** Display the east OSC-CSM card in card view.
- Step 26** Click the **Provisioning > Optical Line > Parameters** tabs. Locate the Port 3 Power value. Verify that the value is higher than -30 dBm. If the power value is not higher than -30 dBm, check your connections and clean the fibers using the “[NTP-G115 Clean Fiber Connectors](#)” procedure on page 13-25. If this does not change the power value, consult your next level of support.
- Step 27** If an OPT-AMP-L card (provisioned in OPT-PRE mode) is installed on the east side, complete the “[DLP-G360 Verify the OPT-AMP-L \(OPT-PRE Mode\) Amplifier Laser and Power](#)” task on page 4-18. If not, continue with [Step 28](#).
- Step 28** Display the west OSC-CSM card in card view.
- Step 29** Click the **Provisioning > Optical Line > Parameters** tabs and locate the Power value for Port 2. Verify that the value is higher than -30 dBm. If the power value is not higher than -30 dBm, check your connections and clean the fibers using the “[NTP-G115 Clean Fiber Connectors](#)” procedure on page 13-25. If this does not change the power value, consult your next level of support.
- Step 30** Disconnect the TXP card or tunable laser from the west OSC-CSM card.
- Step 31** Remove the loopback created on the east OSC-CSM card in [Step 19](#).
- Step 32** Delete both OSC channels. See the “[DLP-G186 Delete an OSC Termination](#)” task on page 10-44.
- Step 33** Complete the “[NTP-G37 Run Automatic Node Setup](#)” procedure on page 3-82 to restore the original configuration.
- Step 34** Create the OSC channels using the “[NTP-G38 Provision OSC Terminations](#)” procedure on page 3-83.
- Stop. You have completed this procedure.**
-

NTP-G47 Perform the C-Band Line Amplifier Node with OSCM and OSC-CSM Cards Acceptance Test

Purpose	This procedure tests a C-band line amplifier node provisioned with an OSC-CSM card installed on one side of the shelf and an OSCM card installed on the other. This test verifies that a line amplifier node provisioned is operating properly before you connect it to the network. The test verifies the operation of the amplifiers and checks the power levels at each transmit and receive port to ensure that power loss in the cabling is within tolerance.
Tools/Equipment	One of the following: <ul style="list-style-type: none"> • A tunable laser or • TXP_MR_10E_C card An optical power meter or optical spectrum analyzer 2 bulk attenuators (10 dB) with LC connectors
Prerequisite Procedures	Chapter 3, “Turn Up a Node”
Required/As Needed	Required
Onsite/Remote	Onsite
Security Level	Superuser

**Note**

Optical power measurements require either a tunable laser or a multirate transponder to generate the proper optical wavelength. If multirate transponders were installed during completion of [Chapter 3, “Turn Up a Node,”](#) they can be used for this procedure. No additional cabling changes are needed.

**Note**

Because the node is isolated and no line-side fibers are connected during the test, the power levels going into the line-side cards will not be the same as the levels when the node is connected to the network. Therefore, if the line amplifier shelf does not contain OPT-BST or OPT-BST-E and OPT-PRE amplifiers on both the east and west sides, you must lower the OPT-PRE power thresholds so that it turns on properly. At the end of the test, you will run automatic node setup (ANS) to configure the node with the correct parameters for the network acceptance test.

-
- Step 1** Complete the [“DLP-G46 Log into CTC” task on page 2-25](#) at the node where you want to perform the acceptance test. If you are already logged in, continue with [Step 2](#).
- Step 2** If you are using TXP_MR_10E_C cards, complete the [“DLP-G268 Provision TXP_MR_10E_C Cards for Acceptance Testing” task on page 4-4](#). If not, continue with [Step 3](#).
- Step 3** Display the terminal node in node view (single-shelf mode) or multishelf view (multishelf mode).
- Step 4** Click the **Alarms** tab.
- Verify that the alarm filter is not on. See the [“DLP-G128 Disable Alarm Filtering” task on page 8-28](#) as necessary.
 - Verify that no equipment alarms appear indicating equipment failure or other hardware problems. (Equipment alarms are indicated by an EQPT in the Alarms tab Cond column.) If alarms appear, investigate and resolve them before continuing. Refer to the *Cisco ONS 15454 DWDM Troubleshooting Guide* for procedures.



Note The OSC terminations created during node turn-up will generate two alarms for each side of the shelf, one for an LOS on the OPT-BST or OPT-BST-E card, and the other for an LOS on the OSC-CSM or OSCM card.

- Step 5** In node view (single-shelf mode) or multishelf view (multishelf mode), click the **Provisioning > WDM-ANS > Port Status** tabs. Verify that all statuses under Link Status are listed as Success - Changed, Success - Unchanged, or Not Applicable. If any are not, complete the following:
- Delete the two OSC channels using the “[DLP-G186 Delete an OSC Termination](#)” task on page 10-44.
 - Complete the “[NTP-G37 Run Automatic Node Setup](#)” procedure on page 3-82.
 - Create the OSC channels using the “[NTP-G38 Provision OSC Terminations](#)” procedure on page 3-83.

- Step 6** Create a loopback on the OSC-CSM card by connecting the LINE TX port to the LINE RX port using a patchcord and 10-dB bulk attenuator.



Caution Failure to use proper attenuation might damage equipment.

- Step 7** Wait 90 to 100 seconds, then in node view (single-shelf mode) or multishelf view (multishelf mode) click the **Alarms** tab. Verify that the LOS alarm on the OSC-CSM card has cleared. The clearing of the LOS alarm indicates that the OSC link is active for this side of the shelf.



Note An SDCC Termination Failure alarm will continue to appear due to the OSC signal loopback.

If the alarm clears, continue with [Step 8](#). If not, perform the following steps:

- Remove the 10-dB bulk attenuator on the OSC-CSM LINE TX and LINE RX ports and reconnect using only the patchcord.
 - In node view (single-shelf mode) or multishelf view (multishelf mode), click the **Alarms** tab. If the LOS alarm on the OSC-CSM card clears, continue with [Step 8](#). If not, continue with [Step c](#).
 - Display the OSC-CSM card in card view.
 - Click the **Provisioning > Optical Line > Optics Thresholds** tabs.
 - Under Types, click **Alarm**, then click **Refresh**.
 - Locate the Port 3 Power Failure Low parameter. Double-click the table cell and change the value to -30 dBm.
 - Locate the Port 6 Power Failure Low parameter. Double-click the table cell and change the value to -40 dBm.
 - Click **Apply**, and then **Yes**.
 - In node view (single-shelf mode) or multishelf view (multishelf mode), click the **Alarms** tab. If the LOS alarm on the OSC-CSM card clears, continue with [Step 8](#). If not, replace the OSC-CSM card.
- Step 8** If you are using a tunable laser, follow the manufacturer’s instructions to complete the following steps. If you are using a TXP_MR_10E_C card, continue with [Step 9](#).
- Set the output power to a nominal value, such as -3 dBm.
 - Set the tuner to the wavelength under test, then continue with [Step 10](#).

- Step 9** If you are using a TXP_MR_10E_C card, complete the “[DLP-G268 Provision TXP_MR_10E_C Cards for Acceptance Testing](#)” task on page 4-4 for the TXP containing the wavelength you will test. Refer to [Table 4-1 on page 4-21](#), if needed.
- Step 10** Measure the TXP output power by connecting the TXP DWDM TX port to a test meter. Record the results for future reference.
- Step 11** Connect the tunable laser transmitter or the TXP_MR_10E_C card DWDM TX port to the OPT-BST or OPT-BST-E LINE RX port using a fiber patchcord and 10-dB bulk attenuator.



Caution Failure to use proper attenuation might damage equipment.

- Step 12** If an OPT-PRE card is installed on the side opposite the OSC-CSM, complete the “[DLP-G80 Verify the OPT-PRE Amplifier Laser and Power](#)” task on page 4-6. If not, continue with [Step 13](#).
- Step 13** Display the OSC-CSM card in card view.
- Step 14** Click the **Provisioning > Optical Line > Parameters** tabs and locate the Port 2 (COM-RX) Power value. Verify that the value is higher than –30 dBm. If the power value is not higher than –30 dBm, check your connections and clean the fibers using the “[NTP-G115 Clean Fiber Connectors](#)” procedure on page 13-25. If this does not change the power value, consult your next level of support.
- Step 15** If an OPT-PRE card is installed on the same side as the OSC-CSM, complete the “[DLP-G80 Verify the OPT-PRE Amplifier Laser and Power](#)” task on page 4-6. If not, continue with [Step 16](#).
- Step 16** Complete the “[DLP-G79 Verify the OPT-BST, OPT-BST-E, or OPT-BST-L Amplifier Laser and Power](#)” task on page 4-5 for the OPT-BST or OPT-BST-E card.
- Step 17** Disconnect the TXP or tunable laser from the OPT-BST or OPT-BST-E card.
- Step 18** Remove the loopback fiber on the OSC-CSM card.
- Step 19** Delete both OSC channels. See the “[DLP-G186 Delete an OSC Termination](#)” task on page 10-44.
- Step 20** Complete the “[NTP-G37 Run Automatic Node Setup](#)” procedure on page 3-82 to restore the original configuration.
- Step 21** Create the OSC channels using the “[NTP-G38 Provision OSC Terminations](#)” procedure on page 3-83.
- Step 22** Create a loopback on the OPT-BST or OPT-BST-E card by connecting the LINE TX port with LINE RX port using a patchcord and 10-dB bulk attenuator.
- Step 23** Wait 90 to 100 seconds, then in node view (single-shelf mode) or multishelf view (multishelf mode) click the **Alarms** tab. Verify that the LOS alarms on the OPT-BST or OPT-BST-E and OSCM cards have cleared. The clearing of the LOS alarms indicates that the OSC link is active for this side of the shelf.



Note A SDCC Termination Failure alarm will continue to appear due to the OSC signal loopback.

If the alarms clear, continue with [Step 24](#). If not, perform the following steps:

- a. Display the OPT-BST or OPT-BST-E card in card view.
- b. Click the **Provisioning > Optical Line > Optics Thresholds** tabs.
- c. Under Types, click **Alarms**, then click **Refresh**.
- d. Locate the Port 2 (COM-TX) Power Failure Low parameter. Double-click the table cell and change the value to –30 dBm.
- e. Locate the Port 4 (OSC-TX) Power Failure Low parameter. Double-click the table cell and change the value to –40 dBm.

- f. Click **Apply**, and then **Yes**.
 - g. Wait 90 to 100 seconds, then in node view (single-shelf mode) or multishelf view (multishelf mode) click the **Alarms** tab. Verify that the LOS alarms on the OPT-BST or OPT-BST-E card has cleared. If so, continue with [Step 24](#). If not, disconnect the OSCM card from the OPT-BST or OPT-BST-E card.
 - h. Create a loopback on the OSCM card by connecting a patch cable from the OSC TX port to the OSC RX port using a 10-dB bulk attenuator.
 - i. Wait 90 to 100 seconds, then in node view (single-shelf mode) or multishelf view (multishelf mode) click the **Alarms** tab. Verify that the LOS alarm on the OSCM card has cleared. If not, check your connections and clean the fibers using the “[NTP-G115 Clean Fiber Connectors](#)” procedure on [page 13-25](#). If this does not change the power value, consult your next level of support.
- Step 24** Connect the tunable laser transmitter or the TXP_MR_10E_C card DWDM TX port to the OSC-CSM LINE RX port using a fiber patchcord and 10-dB bulk attenuator.
- Step 25** If an OPT-PRE is installed on the same side of the shelf as the OSC-CSM, complete the “[DLP-G80 Verify the OPT-PRE Amplifier Laser and Power](#)” task on [page 4-6](#). If not, continue with [Step 26](#).
- Step 26** Complete the “[DLP-G79 Verify the OPT-BST, OPT-BST-E, or OPT-BST-L Amplifier Laser and Power](#)” task on [page 4-5](#) for the OPT-BST or OPT-BST-E card.
- Step 27** Display the OSC-CSM card in card view.
- Step 28** Click the **Provisioning > Optical Line > Parameters** tabs. Verify that the power value on Port 3 (COM-TX) is equal to the optical power from the tunable laser or TXP_MR_10E_C card (measured in [Step 10](#)) -10dB , $\pm 2\text{ dB}$. If not, check your connections and clean the fibers using the “[NTP-G115 Clean Fiber Connectors](#)” procedure on [page 13-25](#). If this does not change the power value, consult your next level of support.
- Step 29** If an OPT-PRE card is installed on the side opposite the OSC-CSM, complete the “[DLP-G80 Verify the OPT-PRE Amplifier Laser and Power](#)” task on [page 4-6](#). If not, continue with [Step 30](#).
- Step 30** Disconnect the TXP or tunable laser from the OSC-CSM card.
- Step 31** Remove the loopback fiber on the OPT-BST or OPT-BST-E amplifier card.
- Step 32** Delete both OSC channels. See the “[DLP-G186 Delete an OSC Termination](#)” task on [page 10-44](#).
- Step 33** Complete the “[NTP-G37 Run Automatic Node Setup](#)” procedure on [page 3-82](#) to restore the original configuration.
- Step 34** Create the OSC channels using the “[NTP-G38 Provision OSC Terminations](#)” procedure on [page 3-83](#).
- Stop. You have completed this procedure.**
-

NTP-G157 Perform the L-Band Line Amplifier Node with OSCM and OSC-CSM Cards Acceptance Test

Purpose	This procedure tests a L-band line amplifier node with an OSC-CSM card installed on one side of the shelf and an OSCM card installed on the other.
Tools/Equipment	One of the following: <ul style="list-style-type: none"> • A tunable laser or • TXP_MR_10E_L card An optical power meter or optical spectrum analyzer 2 bulk attenuators (10 dB) with LC connectors
Prerequisite Procedures	Chapter 3, “Turn Up a Node”
Required/As Needed	Required
Onsite/Remote	Onsite
Security Level	Superuser

Note

Optical power measurements require either a tunable laser or a multirate transponder to generate the proper optical wavelength. If multirate transponders were installed during completion of [Chapter 3, “Turn Up a Node,”](#) they can be used for this procedure. No additional cabling changes are needed.

-
- Step 1** Complete the [“DLP-G46 Log into CTC” task on page 2-25](#) at the node where you want to perform the acceptance test. If you are already logged in, continue with [Step 2](#).
- Step 2** If you are using TXP_MR_10E_L cards, complete the [“DLP-G358 Provision TXP_MR_10E_L Card for Acceptance Testing” task on page 4-16](#). If not, continue with [Step 3](#).
- Step 3** From the View menu, choose **Go to Home View**.
- Step 4** Click the **Alarms** tab.
- Verify that the alarm filter is not on. See the [“DLP-G128 Disable Alarm Filtering” task on page 8-28](#) as necessary.
 - Verify that no equipment alarms appear indicating equipment failure or other hardware problems. (Equipment alarms are indicated by an EQPT in the Alarms tab Cond column.) If alarms appear, investigate and resolve them before continuing. Refer to the *Cisco ONS 15454 DWDM Troubleshooting Guide* for procedures.

Note

The OSC terminations created during node turn-up will generate two alarms for each side of the shelf, one for an LOS on the OPT-BST-L card, and the other for an LOS on the OSC-CSM or OSCM card. If OSCM cards are installed, SDCC termination failure (EOC) alarms will appear.

- Step 5** In node view (single-shelf mode) or multishelf view (multishelf mode), click the **Provisioning > WDM-ANS > Port Status** tabs. Verify that all statuses under Link Status are listed as Success - Changed, Success - Unchanged, or Not Applicable. If any are not, complete the following:
- Delete the two OSC channels using the [“DLP-G186 Delete an OSC Termination” task on page 10-44](#).
 - Complete the [“NTP-G37 Run Automatic Node Setup” procedure on page 3-82](#).

- c. Create the OSC channels using the “[NTP-G38 Provision OSC Terminations](#)” procedure on [page 3-83](#).

Step 6 Create a loopback on the OSC-CSM card by connecting the LINE TX port to the LINE RX port using a fiber patchcord and 10-dB bulk attenuator.



Caution Failure to use proper attenuation might damage equipment.

Step 7 Wait 90 to 100 seconds, then in node view (single-shelf mode) or multishelf view (multishelf mode) click the **Alarms** tab. Verify that the LOS alarm on the OSC-CSM card has cleared. The clearing of the LOS alarm indicates that the OSC link is active for this side of the shelf.



Note An SDCC Termination Failure alarm will continue to appear due to the OSC signal loopback.

If the alarm clears, continue with [Step 8](#). If not, perform the following steps:

- a. Remove the 10-dB bulk attenuator on the OSC-CSM LINE TX and LINE RX ports and reconnect using only the patchcord.
- b. In node view (single-shelf mode) or multishelf view (multishelf mode), click the **Alarms** tab. If the LOS alarm on the OSC-CSM card clears, continue with [Step 8](#). If not, continue with [Step c](#).
- c. Display the OSC-CSM card in card view.
- d. Click the **Provisioning > Optical Line > Optics Thresholds** tabs.
- e. Under Types, click **Alarm**, then click **Refresh**.
- f. Locate the Port 3 Power Failure Low parameter. Double-click the table cell and change the value to -30 dBm.
- g. Locate the Port 6 Power Failure Low parameter. Double-click the table cell and change the value to -40 dBm.
- h. Click **Apply**, and then **Yes**.
 - i. In node view (single-shelf mode) or multishelf view (multishelf mode), click the **Alarms** tab. If the LOS alarm on the OSC-CSM card clears, continue with [Step 8](#). If not, replace the OSC-CSM card.

Step 8 If you are using a tunable laser, follow the manufacturer’s instructions to complete the following steps. If you are using a TXP_MR_10E_L card, continue with [Step 9](#).

- a. Set the output power to a nominal value, such as -3 dBm.
- b. Set the tuner to the wavelength under test, then continue with [Step 10](#).

Step 9 If you are using a TXP_MR_10E_L card, complete the “[DLP-G358 Provision TXP_MR_10E_L Card for Acceptance Testing](#)” task on [page 4-16](#) for the wavelength you will test.

Step 10 Measure the TXP card output power by connecting the TXP card DWDM TX port to a test meter. Record the results for future reference.

Step 11 Connect the tunable laser transmitter or the TXP_MR_10E_L card DWDM TX port to the OPT-BST-L LINE RX port using a 10-dB bulk attenuator.



Caution Failure to use proper attenuation might damage equipment.

Step 12 Display the OPT-BST-L card in card view.

- Step 13** Click the **Provisioning > Optical Line > Parameters** tabs. Verify that the power value on Port 2 (Out Com) is equal to the optical power from the tunable laser or TXP_MR_10E_L card (measured in [Step 10](#)) +/- 1 dBm.
- Step 14** If an OPT-AMP-L card (provisioned in OPT-PRE mode) is installed on the side opposite the OSC-CSM card, complete the “[DLP-G360 Verify the OPT-AMP-L \(OPT-PRE Mode\) Amplifier Laser and Power](#)” task on page 4-18. If not, continue with [Step 15](#).
- Step 15** Display the OSC-CSM card in card view.
- Step 16** Click the **Provisioning > Optical Line > Parameters** tabs and locate the Port 3 Power value. Verify that the value is higher than -30 dBm. If the power value is not higher than -30 dBm, check your connections and clean the fibers using the “[NTP-G115 Clean Fiber Connectors](#)” procedure on page 13-25. If this does not change the power value, consult your next level of support.
- Step 17** If an OPT-AMP-L card (provisioned in OPT-PRE mode) is installed on the same side as the OSC-CSM, complete the “[DLP-G360 Verify the OPT-AMP-L \(OPT-PRE Mode\) Amplifier Laser and Power](#)” task on page 4-18. If not, continue with [Step 18](#).
- Step 18** Complete the “[DLP-G359 Verify the OPT-BST-L or OPT-AMP-L \(OPT-Line Mode\) Amplifier Laser and Power](#)” task on page 4-17 for the OPT-BST-L card.
- Step 19** Disconnect the TXP card or tunable laser from the OPT-BST-L card.
- Step 20** Remove the loopback fiber on the OSC-CSM card.
- Step 21** Delete both OSC channels. See the “[DLP-G186 Delete an OSC Termination](#)” task on page 10-44.
- Step 22** Complete the “[NTP-G37 Run Automatic Node Setup](#)” procedure on page 3-82 to restore the original configuration.
- Step 23** Create the OSC channels using the “[NTP-G38 Provision OSC Terminations](#)” procedure on page 3-83.
- Step 24** Create a loopback on the OPT-BST-L card by connecting the LINE TX port with LINE RX port using a patchcord and 10-dB bulk attenuator.
- Step 25** Wait 90 to 100 seconds, then in node view (single-shelf mode) or multishelf view (multishelf mode) click the **Alarms** tab. Verify that the LOS alarms on the OPT-BST-L and OSCM cards have cleared. The clearing of the LOS alarms indicates that the OSC link is active for this side of the shelf.



Note An SDCC Termination Failure alarm will continue to appear due to the OSC signal loopback.

If the alarms clear, continue with [Step 26](#). If not, perform the following steps:

- a. Display the OPT-BST-L card in card view.
- b. Click the **Provisioning > Optical Line > Optics Thresholds** tabs.
- c. Under Types, click **Alarms**, then click **Refresh**.
- d. Locate the Port 2 Power Failure Low parameter. Double-click the table cell and change the value to -30 dBm.
- e. Locate the Port 4 Power Failure Low parameter. Double-click the table cell and change the value to -40 dBm.
- f. Click **Apply**, and then **Yes**.
- g. Wait 90 to 100 seconds, then in node view (single-shelf mode) or multishelf view (multishelf mode) click the **Alarms** tab. Verify that the LOS alarms on the OPT-BST-L card has cleared. If so, continue with [Step 26](#). If not, disconnect the OSCM card from the OPT-BST-L card.
- h. Create a loopback on the OSCM card by connecting a patch cable from the OSC TX port to the OSC RX port using a 10-dB bulk attenuator.

- i. Wait 90 to 100 seconds, then in node view (single-shelf mode) or multishelf view (multishelf mode) click the **Alarms** tab. Verify that the LOS alarm on the OSCM card has cleared. If so, replace the OPT-BST-L card. If not, replace the OSCM card. See the “[NTP-G30 Install the DWDM Cards](#)” procedure on page 3-44.
 - Step 26** Connect the tunable laser transmitter or the TXP_MR_10E_L card DWDM TX port to the OSC-CSM LINE RX port using a 10-dB bulk attenuator.
 - Step 27** If an OPT-AMP-L card (provisioned in OPT-PRE mode) is installed on the same side of the shelf as the OSC-CSM, complete the “[DLP-G360 Verify the OPT-AMP-L \(OPT-PRE Mode\) Amplifier Laser and Power](#)” task on page 4-18. If not, continue with Step 28.
 - Step 28** Complete the “[DLP-G359 Verify the OPT-BST-L or OPT-AMP-L \(OPT-Line Mode\) Amplifier Laser and Power](#)” task on page 4-17 for the OPT-BST-L card.
 - Step 29** Display the OSC-CSM card in card view.
 - Step 30** Click the **Provisioning > Optical Line > Parameters** tabs. Verify that the power value on Port 3 (Out Com) is equal to the optical power from the tunable laser or TXP_MR_10E_L card (measured in [Step 10](#)) +/- 1 dBm.
 - Step 31** If an OPT-AMP-L card (provisioned in OPT-PRE mode) is installed on the side opposite the OSC-CSM, complete the “[DLP-G360 Verify the OPT-AMP-L \(OPT-PRE Mode\) Amplifier Laser and Power](#)” task on page 4-18. If not, continue with Step 32.
 - Step 32** Disconnect the TXP card or tunable laser from the OSC-CSM card.
 - Step 33** Remove the loopback fiber on the OPT-BST-L amplifier card.
 - Step 34** Delete both OSC channels. See the “[DLP-G186 Delete an OSC Termination](#)” task on page 10-44.
 - Step 35** Complete the “[NTP-G37 Run Automatic Node Setup](#)” procedure on page 3-82 to restore the original configuration.
 - Step 36** Create the OSC channels using the “[NTP-G38 Provision OSC Terminations](#)” procedure on page 3-83.
- Stop. You have completed this procedure.**
-

NTP-G48 Perform the OADM Node Acceptance Test on a Symmetric Node with OSCM Cards

Purpose	This procedure checks the integrity of all the optical connections inside an OADM node with OSCM cards installed on both the east and west sides of the shelf. Three connection types are tested: <ul style="list-style-type: none"> • Express • Pass-through • Add/Drop
Tools/Equipment	A tunable laser or a TXP_MR_10E_C card An optical power meter or optical spectrum analyzer Two bulk attenuators (10 dB) with LC connectors
Prerequisite Procedures	Chapter 3, “Turn Up a Node.”
Required/As Needed	Required
Onsite/Remote	Onsite
Security Level	Superuser

Note

Optical power measurements require either a tunable laser or a multirate transponder to generate the proper optical wavelength. If multirate transponders were installed during completion of [Chapter 3, “Turn Up a Node,”](#) they can be used for this procedure. No additional cabling changes are needed.

-
- Step 1** Complete the [“DLP-G46 Log into CTC” task on page 2-25](#) at the OADM node where you want to perform the acceptance test. If you are already logged in, continue with Step 2.
- Step 2** From the View menu, choose **Go to Network View**.
- Step 3** Click the **Alarms** tab.
- Verify that the alarm filter is not on. See the [“DLP-G128 Disable Alarm Filtering” task on page 8-28](#) as necessary.
 - Verify that no equipment alarms appear indicating equipment failure or other hardware problems. (Equipment alarms are indicated by an EQPT in the Alarms tab Cond column.) If equipment failure alarms appear, investigate and resolve them before continuing. Refer to the *Cisco ONS 15454 DWDM Troubleshooting Guide* for procedures.
- Step 4** In node view (single-shelf mode) or multishelf view (multishelf mode), click the **Provisioning > WDM-ANS > Port Status** tabs. Verify that all statuses under Link Status are Success - Changed, Success - Unchanged, or Not Applicable. If not, complete the [“NTP-G37 Run Automatic Node Setup” procedure on page 3-82](#).
- Step 5** Check your Cisco MetroPlanner site configuration file to verify the presence of added and dropped bands (including four channels at 100 GHz) configured in pass-through mode in either direction.

Note

Configuring a band in pass-through mode means that the band is dropped in one direction by an AD-xB-xx.x card on one side (east or west) of the node, then added by another AD-xB-x.xx card on the opposite side in the same direction. The band is not terminated inside the node.

Step 6 If no bands are configured in pass-through mode, continue with [Step 7](#). If a band is configured in pass-through mode, mark it and skip the related optical test for the express, add, and drop sections. Band pass-through connections are verified separately.

Step 7 Check the site configuration file from Cisco MetroPlanner to verify the presence of dropped or added channels configured in pass-through mode in either direction.



Note Configuring a channel in pass-through mode means that the channel is dropped in one direction by an AD-xC-xx.x card on one side (east or west) of the node, then added by another AD-xC-x.xx card on the opposite side in the same direction. The channel is not terminated inside the node.

Step 8 If no channels are configured in pass-through mode, continue with [Step 9](#). If a channel is configured in pass-through mode, mark it and skip the related optical test for the express, add, and drop sections. Channel pass-through connections are verified separately.

Step 9 Create a loopback on the west OPT-BST or OPT-BST-E card by connecting the LINE TX port to the LINE RX port using a patchcord and 10-dB bulk attenuator.

Step 10 Verify that the OSC link becomes active on the west OSCM card. (The OSC termination must be already provisioned. If not, complete the “[NTP-G38 Provision OSC Terminations](#)” procedure on page 3-83.) If the OSC link becomes active, continue with [Step 11](#). If the OSC link does not turn up, complete the following steps:

- a. Modify the OSC Fail Low thresholds. Click the **Provisioning > Optical Line > Optics Thresholds** tabs and change the Port 4 opwrMin (minimum power) to -40 dBm.
- b. Modify the COM TX Fail Low Threshold. Change the Port 2 opwrMin (minimum power) to -30 dBm.
- c. If the OSC link turns up, continue with [Step 11](#). If the OSC link is still down, disconnect the OSCM card from the OPT-BST or OPT-BST-E card.
- d. Create a loopback on the OSCM card by connecting patch cable from the OSC TX port to the OSC RX port using a 10-dB bulk attenuator.
- e. If the OSC link turns up, replace the OPT-BST or OPT-BST-E card. If the OSC link does not turn up, replace the OSCM card.



Note Due to the OSC signal loopback, an SDCC Termination Failure alarm might be raised.

Step 11 If the node has express bands or channels, complete the “[DLP-G85 Verify Express Channel Connections on an OADM Node with OSCM Cards](#)” task on page 4-92. If the node does not have express bands or channels, continue with [Step 12](#).

Step 12 If connections configured in pass-through mode are present (noted in Steps 6 and 8), complete the “[DLP-G89 Verify OADM Node Pass-Through Channel Connections](#)” task on page 4-94. If not, continue with [Step 13](#).

Step 13 If connections have add/drop connections, complete the “[DLP-G93 Verify Add and Drop Connections on an OADM Node with OSCM Cards](#)” task on page 4-98.

Stop. You have completed this procedure.

DLP-G85 Verify Express Channel Connections on an OADM Node with OSCM Cards

Purpose	This task verifies the express channel connections during an OADM node acceptance test.
Tools/Equipment	A tunable laser or a TXP_MR_10E_C
Prerequisite Procedures	DLP-G46 Log into CTC, page 2-25
Required/As Needed	As needed
Onsite/Remote	Onsite
Security Level	Superuser

-
- Step 1** If you are using a tunable laser, set the output power to a nominal value, such as -3 dBm. If not, continue with [Step 2](#).
- Step 2** Connect the tunable laser transmitter or the TXP_MR_10E_C card DWDM TX port to the east OPT-BST or OPT-BST-E LINE RX port.
- Step 3** Based on the Cisco MetroPlanner site configuration file, tune the tunable laser of TXP_MR_10E_C card to a wavelength (on the 100-GHz ITU-T grid) that runs on the express path of all AD-xB-xx.x and AD-xC-xx.x cards on the east-to-west and west-to-east directions. Refer to the tunable laser manufacturer's documentation or the "[DLP-G268 Provision TXP_MR_10E_C Cards for Acceptance Testing](#)" task on page 4-4.
- Step 4** If an OPT-PRE card is installed on the east side, insert a 10-dB bulk attenuator on the COM RX port and complete the "[DLP-G80 Verify the OPT-PRE Amplifier Laser and Power](#)" task on page 4-6. If an OPT-PRE card is not installed on the east side, continue with [Step 5](#).
- Step 5** If AD-xB-xx.x cards are installed on the east side, complete the "[DLP-G87 Verify the AD-xB-xx.x Output Express Power](#)" task on page 4-93 for each east side card. If not, continue with [Step 6](#).



Note If AD-xB-xx.x and AD-xC-xx.x cards are both installed in one direction, the received express channels will go into the AD-xB-xx.x cards first, then into the AD-xC-xx.x cards.

- Step 6** If AD-xC-xx.x cards are installed on the east side, complete the "[DLP-G88 Verify the AD-xC-xx.x Output Express Power](#)" task on page 4-93 for each east side card. If not, continue with [Step 7](#).
- Step 7** If AD-xC-xx.x cards are installed on the west side, complete the "[DLP-G271 Verify the AD-xC-xx.x Output Common Power](#)" task on page 4-94 for each west side card. If not, continue with [Step 8](#).
- Step 8** If AD-xB-xx.x cards are installed on the west side, complete the "[DLP-G272 Verify the AD-xB-xx.x Output Common Power](#)" task on page 4-94 for each west side card. If not, continue with [Step 9](#).
- Step 9** Complete the "[DLP-G79 Verify the OPT-BST, OPT-BST-E, or OPT-BST-L Amplifier Laser and Power](#)" task on page 4-5 for the OPT-BST or OPT-BST-E card installed on the east side.
- Step 10** If an OPT-PRE card is installed on the west side, complete the "[DLP-G80 Verify the OPT-PRE Amplifier Laser and Power](#)" task on page 4-6. If an OPT-PRE card is not installed, continue with [Step 11](#).
- Step 11** Repeat Steps 5 through 8 for the AD-xB-xx.x and AD-xC-xx.x cards along the west-to-east direction.
- Step 12** Complete the "[DLP-G79 Verify the OPT-BST, OPT-BST-E, or OPT-BST-L Amplifier Laser and Power](#)" task on page 4-5 for the OPT-BST or OPT-BST-E card installed on the east side.

Step 13 Return to the originating procedure (NTP).

DLP-G87 Verify the AD-xB-xx.x Output Express Power

Purpose	This task verifies the output express power of AD-xB-xx.x cards.
Tools/Equipment	None
Prerequisite Procedures	DLP-G46 Log into CTC, page 2-25
Required/As Needed	As needed
Onsite/Remote	Onsite or remote
Security Level	Superuser

- Step 1** Display the AD-xB-xx.x card in card view.
- Step 2** Click the **Provisioning > Optical Line > Parameters** tabs.
- Step 3** Change the Output Express port administrative state to **OOS,MT (ANSI)** or **Locked,maintenance (ETSI)**. Click **Apply**.
- Step 4** Verify that the Output Express port Power value is greater than the default no-power value of -28 dBm.
- Step 5** Return to your originating procedure (NTP).
-

DLP-G88 Verify the AD-xC-xx.x Output Express Power

Purpose	This task verifies the output express power of the AD-xC-xx.x cards.
Tools/Equipment	None
Prerequisite Procedures	DLP-G46 Log into CTC, page 2-25
Required/As Needed	As needed
Onsite/Remote	Onsite or remote
Security Level	Superuser

- Step 1** Display the AD-xC-xx.x card in card view.
- Step 2** Click the **Provisioning > Optical Line > Parameters** tabs.
- Step 3** Change the Output Express port administrative state to **OOS,MT (ANSI)** or **Locked,maintenance (ETSI)**. Click **Apply**.
- Step 4** Verify that the Output Express port Power value is greater than the default no-power value of -30 dBm.
- Step 5** Return to your originating procedure (NTP).
-

DLP-G271 Verify the AD-xC-xx.x Output Common Power

Purpose	This task verifies the common power of the AD-xC-xx.x cards.
Tools/Equipment	None
Prerequisite Procedures	DLP-G46 Log into CTC, page 2-25
Required/As Needed	As needed
Onsite/Remote	Onsite or remote
Security Level	Superuser

-
- Step 1** Display the AD-xC-xx.x card in card view.
- Step 2** Click the **Provisioning > Optical Line > Parameters** tabs.
- Step 3** Verify that the Output Com port Power value is greater than the default no-power value of –30 dBm.
- Step 4** Return to your originating procedure (NTP).
-

DLP-G272 Verify the AD-xB-xx.x Output Common Power

Purpose	This task verifies the output common power of the AD-xB-xx.x cards.
Tools/Equipment	None
Prerequisite Procedures	DLP-G46 Log into CTC, page 2-25
Required/As Needed	As needed
Onsite/Remote	Onsite or remote
Security Level	Superuser

-
- Step 1** Display the AD-xB-xx.x card in card view.
- Step 2** Click the **Provisioning > Optical Line > Parameters** tabs.
- Step 3** Verify that the Output Com port Power value is greater than the default no-power value of –28 dBm.
- Step 4** Return to your originating procedure (NTP).
-

DLP-G89 Verify OADM Node Pass-Through Channel Connections

Purpose	This task verifies the pass-through channel connections during an OADM node acceptance test.
Tools/Equipment	A tunable laser or a TXP_MR_10E_C
Prerequisite Procedures	DLP-G46 Log into CTC, page 2-25
Required/As Needed	As needed

Onsite/Remote	Onsite
Security Level	Superuser

-
- Step 1** Identify the first band connection configured in pass-through mode in both directions.
- Step 2** Set the tunable laser or TXP_MR_10E_C card to the wavelength of the band to be tested. Refer to the tunable laser manufacturer’s documentation or the [“DLP-G268 Provision TXP_MR_10E_C Cards for Acceptance Testing” task on page 4-4](#).
- Step 3** Complete the [“DLP-G90 Verify an AD-xB-xx.x Pass-Through Connection Power” task on page 4-96](#) for the first pass-through connection.
- Step 4** (Optional) Complete one of the following:
- If OSCM cards are installed, connect a power meter to the east OPT-BST or OPT-BST-E LINE TX port and verify that the east amplifier is turned on by the pass-through wavelength.
 - If OSC-CSM cards are installed, complete the [“DLP-G84 Verify the OSC-CSM Incoming Power” task on page 4-97](#) for the east OSC-CSM card.
- Step 5** Complete Steps 2 through 4 for all band connections configured in pass-through mode in both directions.
- Step 6** If channel pass-through connections are not present, continue with [Step 15](#). If channel pass-through connections are present, continue with one of the following steps:
- If the pass-through channel connections use an AD-xC-xx.x card, continue with [Step 7](#).
 - If the pass-through channel connections use a 4MD-xx.x card, continue with [Step 11](#).
- Step 7** Tune the tunable laser on a wavelength (1 of 4) belonging to the channel to be tested.
- Step 8** Complete the [“DLP-G91 Verify an AD-xC-xx.x Pass-Through Connection” task on page 4-96](#) for the first pass-through connection.
- Step 9** (Optional) Complete one of the following:
- If an OSCM card is installed, connect a power meter to LINE TX port on the front-pane and verify that the east OPT-BST or OPT-BST-E amplifier is turned on by the pass-through wavelength.
 - If an OSC-CSM card is installed, complete the [“DLP-G84 Verify the OSC-CSM Incoming Power” task on page 4-97](#) for the east OSC-CSM card.
- Step 10** If the pass-through connections use a 4MD-xx.x, continue with [Step 11](#). If not, continue with [Step 15](#).
- Step 11** Identify the first channel connection that is configured in pass-through mode using the 4MD-xx.x cards in both directions.
- Step 12** Tune the tunable laser on the corresponding wavelength.
- Step 13** Complete the [“DLP-G92 Verify 4MD-xx.x Pass-Through Connection Power” task on page 4-100](#).
- Step 14** (Optional) Perform one of the following:
- If an OSCM card is installed, connect a power meter to LINE TX port on the card front panel and verify that the east OPT-BST or OPT-BST-E amplifier is turned on by the pass-through wavelength.
 - If an OSC-CSM card is installed, complete the [“DLP-G84 Verify the OSC-CSM Incoming Power” task on page 4-97](#) for the east OSC-CSM card.
- Step 15** Return to your originating procedure (NTP).
-

DLP-G90 Verify an AD-xB-xx.x Pass-Through Connection Power

Purpose	This task verifies an AD-xB-xx.x pass-through connection.
Tools/Equipment	None
Prerequisite Procedures	DLP-G46 Log into CTC, page 2-25
Required/As Needed	As needed
Onsite/Remote	Onsite or remote
Security Level	Superuser

-
- Step 1** Verify the east AD-xB-xx.x band TX power:
- Display the east AD-xB-xx.x card in card view.
 - Click the **Provisioning > Optical Band > Parameters** tabs.
 - Change the administrative state of the BAND TX (east-to-west) port related to the wavelength selected on the tunable laser to **OOS,MT** (ANSI) or **Locked,maintenance** (ETSI). Click **Apply**.
 - Verify that the BAND TX port Power value is higher than the default no-power value of –30 dBm.
- Step 2** Verify the west AD-xB-xx.x card RX and TX power:
- Display the west AD-xB-xx.x card in card view.
 - Click the **Provisioning > Optical Band > Parameters** tabs.
 - Verify that the Power value of the BAND RX (east-to-west) port is higher than the default no-power value of –30 dBm.
 - Change the administrative state of the BAND TX (west-to-east) port related to the wavelength selected on the tunable laser to **OOS,MT** (ANSI) or **Locked,maintenance** (ETSI). Click **Apply**.
 - Verify that the BAND TX port Power value is higher than the default no-power value of –30 dBm.
- Step 3** Verify the BAND RX port on the east AD-xB-xx.x card:
- Display the east AD-xB-xx.x card in card view.
 - Click the **Provisioning > Optical Band > Parameters** tabs.
 - Verify that the Power value of the BAND RX (west-to-east) port is higher than the default no-power value of –30 dBm.
- Step 4** Return to your originating procedure (NTP).
-

DLP-G91 Verify an AD-xC-xx.x Pass-Through Connection

Purpose	This task verifies an AD-xC-xx.x pass-through connection.
Tools/Equipment	None
Prerequisite Procedures	DLP-G46 Log into CTC, page 2-25
Required/As Needed	As needed
Onsite/Remote	Onsite or remote
Security Level	Superuser

-
- Step 1** Verify the east AD-xC-xx.x channel TX power:
- Display the east AD-xC-xx.x card in card view.
 - Click the **Provisioning > Optical Chn > Parameters** tabs.
 - Verify that the power value for the CHAN TX port is higher than the default no-power value of -35 dBm.
 - If the AD-xC-xx.x card is an AD-4C-xx.x card, a VOA (applied to all four channels) is installed along the drop path and needs to be activated in Step e.
 - Change the administrative state of the CHAN TX port related to the wavelength selected on the tunable laser to **OOS,MT** (ANSI) or **Locked,maintenance** (ETSI). Click **Apply**.
 - Verify that the power value of the CHAN TX port is higher than the default no-power value of -35 dBm.
- Step 2** Verify the channel power for the corresponding west AD-xC-xx.x card:
- Display the west AD-xC-xx.x card in card view.
 - Click the **Provisioning > Optical Chn > Parameters** tabs.
 - Verify that the power value of the CHAN TX port is higher than the default no-power value of -35 dBm.
 - Verify that the Power value of the CHAN RX port reaches the provisioned setpoint (VOA Power Ref).
 - Change the administrative state of the CHAN TX port related to the wavelength selected on the tunable laser to **OOS,MT** (ANSI) or **Locked,maintenance** (ETSI). Click **Apply**.
 - If the AD-xC-xx.x is an AD-4C-W card, a VOA (applying to all four channels) is installed along the drop path and needs to be activated in Step g.
 - Change the administrative state of the CHAN TX port related to the wavelength selected on the tunable laser to **OOS,MT** (ANSI) or **Locked,maintenance** (ETSI). Click **Apply**.
 - Verify that the power value of the CHAN TX port is higher than the default no-power value of -35 dBm.
- Step 3** Verify the east AD-xC-xx.x channel RX power:
- Display the east AD-xC-xx.x card in card view.
 - Click the **Provisioning > Optical Chn > Parameters** tabs.
 - Change the administrative state of the CHAN RX port to **OOS,MT** (ANSI) or **Locked,maintenance** (ETSI) for the channel related to the wavelength selected on the tunable laser.
 - Verify that the Power value of the CHAN RX port reaches the provisioned setpoint (VOA Power Ref).
- Step 4** Return to your originating procedure (NTP).
-

DLP-G84 Verify the OSC-CSM Incoming Power

Purpose	This task verifies the OSC-CSM card incoming power.
Tools/Equipment	None

Prerequisite Procedures [DLP-G46 Log into CTC, page 2-25](#)

Required/As Needed As needed

Onsite/Remote Onsite or remote

Security Level Superuser

-
- Step 1** Display the OSC-CSM card in card view.
- Step 2** Click the **Provisioning > Optical Line > Parameters** tabs.
- Step 3** Verify that the Power value for Port 2 is higher than the default no-power value of -30 dBm. The calculated expected power value for Port 2 is:
Pout COM TX of OPT-PRE (this normally is + 2 dBm)



Note Actual output power is affected by many factors. Always consider the calculated expected power to be a general guideline and not a precise value.

- Step 4** Return to your originating procedure (NTP).
-

DLP-G93 Verify Add and Drop Connections on an OADM Node with OSCM Cards

Purpose This task verifies the add and drop channel connections for an OADM node with OSCM cards installed.

Tools/Equipment A tunable laser or a TXP_MR_10E_C card

Prerequisite Procedures [DLP-G46 Log into CTC, page 2-25](#)

Required/As Needed As needed

Onsite/Remote Onsite

Security Level Superuser



Note In this task, you will verify add and drop connections in the following order: east-to-west add and west-to-east drop, Steps 1 through 15; west-to-east add and east-to-west drop, Steps 16 through 17.

-
- Step 1** Based on the Cisco MetroPlanner site configuration file, tune the tunable laser or TXP_MR_10E_C card to a wavelength (belonging to the 100-GHz ITU-T grid) of the channel running on the first add path of the first west AD-xC-xx.x or west 4MD-xx.x card on the east-to-west direction. Refer to the tunable laser manufacturer's documentation or the "[DLP-G268 Provision TXP_MR_10E_C Cards for Acceptance Testing](#)" task on page 4-4.
- Step 2** Connect the tunable laser transmitter or the TXP_MR_10E_C card DWDM TX port to the corresponding 15xx.x RX port (on the card front panel) of the west AD-xC-xx.x or 4MD-xx.x card.
- Step 3** Verify the west AD-xC-xx.x or 4MD-xx.x (east-to-west):
- Display the west AD-xC-xx.x or 4MD-xx.x card in card view.
 - Click the **Provisioning > Optical Chn > Parameters** tabs.
 - Change the administrative state of the CHAN RX port to **OOS,MT** (ANSI) or **Locked,maintenance** (ETSI) for the channel related to the wavelength chosen on the tunable laser.

- d. Verify that the Power value of the CHAN RX port reaches the provisioned setpoint (VOA Power Ref).
- Step 4** Complete the “[DLP-G79 Verify the OPT-BST, OPT-BST-E, or OPT-BST-L Amplifier Laser and Power](#)” task on page 4-5 on the west OPT-BST or OPT-BST-E amplifier to verify that the added wavelength turns on the laser.
- Step 5** If the add connection uses a 4MD-xx.x card, continue with [Step 6](#). If the add connection uses an AD-xC-xx.x card, move to [Step 10](#).
- Step 6** Verify the RX band port on the west AD-xB-xx.x card:
- a. Display the west AD-xB-xx.x card in card view.
 - b. Click the **Provisioning > Optical Band > Parameters** tabs.
- Step 7** Verify that the BAND RX Power value is higher than the default no-power value of –30 dBm.
- Step 8** Verify the band TX port on the west AD-xB-xx.x (west-to-east):
- a. Display the west AD-xB-xx.x card in card view.
 - b. Click the **Provisioning > Optical Band > Parameters** tabs.
 - c. Change the administrative state of the BAND TX port to **OOS,MT (ANSI)** or **Locked,maintenance (ETSI)** for the channel related to the wavelength selected on the tunable laser or TXP_MR_10E_C card.
 - d. Verify that the Power value of the BAND TX port is higher than the default no-power value of –30 dBm.
- Step 9** Verify the west 4MD-xx.x card (west-to-east):
- a. Display the west 4MD-xx.x card in card view.
 - b. Click the **Provisioning > Optical Chn > Parameters** tabs.
 - c. Verify that the Power value of the CHAN TX port is higher than the default no-power value of –30 dBm.
- Step 10** Verify the west AD-xC-xx.x (west-to-east) card:
- a. Display the west AD-xC-xx.x card in card view.
 - b. If the AD-xC-xx.x card is an AD-4C-xx.x card, a VOA (applied to all four channels) is installed along the drop path and needs to be activated according to [Step g](#).
 - c. Click the **Provisioning > Optical Chn > Parameters** tabs.
 - d. Verify that the Power value of the CHAN TX port is higher than the default no-power value of –35 dBm.
 - e. Display the east AD-xC-xx.x card in card view.
 - f. Click the **Provisioning > Optical Chn > Parameters** tabs.
 - g. Change the administrative state of the CHAN TX port related to the wavelength selected on the tunable laser or TXP_MR_10E_C card to **OOS,MT (ANSI)** or **Locked,maintenance (ETSI)**. Click **Apply**.
 - h. Verify that the power value for the CHAN TX port is higher than the default no-power value of –35 dBm.
 - i. Perform the output power check.

- Step 11** (Optional) Connect a power meter to the proper 15xx.x TX port on the front panel (the dual port compared with the port where the tunable laser or TXP_MR_10E_C card is connected). Verify that the physical optical power value from that port is consistent with the value displayed on the Provisioning > Optical Chn > Parameters tab for the proper CHAN TX power value +/- 0.5 dB.
- Step 12** Repeat Steps 6 through 11 for all add paths of any west AD-xC-xx.x or 4MD-xx.x cards along the east-to-west direction.
- Step 13** Remove the loopback on the west OPT-BST or OPT-BST-E amplifier and create a loopback on the east OPT-BST or OPT-BST-E amplifier.
- Step 14** Verify that the OSC link becomes active on the east OSCM card. (The OSC termination must be already provisioned. If not, complete the “[NTP-G38 Provision OSC Terminations](#)” procedure on page 3-83.) If the OSC link becomes active, continue with Step 15. If the OSC link does not become active, perform the following steps:
- Modify the OSC Fail Low thresholds by clicking the **Provisioning > Optical Line > Optics Thresholds** tabs and changing the Port 2 opwrMin (minimum power) to -40 dBm.
 - If the OSC link turns up, continue with Step 15. If the OSC link remains down, disconnect the OSCM card from the OPT-BST or OPT-BST-E card.
 - Create a loopback on the OSCM card by connecting patch cable from the OSC TX port to the OSC RX port using a 10-dB bulk attenuator.
 - If the OSC link turns up, replace the OPT-BST or OPT-BST-E card. If the OSC link does not turn up, replace the OSCM card. See the “[NTP-G30 Install the DWDM Cards](#)” procedure on page 3-44.



Note Due to the OSC signal loopback, an SDCC Termination Failure alarm might be raised.

- Step 15** Based on the Cisco MetroPlanner site configuration file, tune the tunable laser or TXP_MR_10E_C card to a wavelength (belonging to the 100-GHz ITU-T grid) of the channel running on the first add path of the first add path of the first AD-xC-xx.x or 4MD-xx.x card on the west-to-east direction. Refer to the tunable laser manufacturer’s documentation or the “[DLP-G268 Provision TXP_MR_10E_C Cards for Acceptance Testing](#)” task on page 4-4.
- Step 16** Connect the tunable laser transmitter or the TXP_MR_10E_C card DWDM TX port to the correspondent 15xx.x RX port (on the card front panel) of the east AD-xC-xx.x or east 4MD-xx.x card.
- Step 17** Repeat Steps 3 through 15, applying the steps to the west-to-east direction.
- Step 18** Remove the loopback connection and restore the default administrative state (IS,AINS or Unlocked,automaticInService) on all the ports previously set to OOS,MT (ANSI) or Locked,maintenance (ETSI).
- Step 19** Complete the “[NTP-G37 Run Automatic Node Setup](#)” procedure on page 3-82 to recover the correct node configuration.
- Step 20** Return to your originating procedure (NTP).
-

DLP-G92 Verify 4MD-xx.x Pass-Through Connection Power

Purpose	This task verifies 4MD-xx.x pass-through connection.
Tools/Equipment	None

Prerequisite Procedures [DLP-G46 Log into CTC, page 2-25](#)

Required/As Needed As needed

Onsite/Remote Onsite or remote

Security Level Superuser

-
- Step 1** Verify the TX band power on the related east AD-xB-xx.x card:
- Display the east AD-xB-xx.x card in card view.
 - Click the **Provisioning > Optical Band > Parameters** tabs.
 - Change the administrative state of the BAND TX port to **OOS,MT (ANSI)** or **Locked,maintenance (ETSI)** for the channel related to the wavelength selected on the tunable laser.
 - Verify that the BAND TX Power value is higher than the default no-power value of -30 dBm.
- Step 2** Verify the TX power on the related east 4MD-xx.x (east-to-west) card:
- Display the east 4MD-xx.x card in card view.
 - Click the **Provisioning > Optical Chn > Parameters** tabs.
 - Verify that the Power value on the CHAN TX port is higher than the default no-power value of -35 dBm.
- Step 3** Verify the RX band power on the west AD-xB-xx.x card (east-to-west):
- Display the west AD-xB-xx.x card in card view.
 - Click the **Provisioning > Optical Band > Parameters** tabs.
 - Verify that the BAND RX Power value is higher than the default no-power values of -30 dBm.
- Step 4** Verify the west 4MD-xx.x (east-to-west):
- Display the west 4MD-xx.x card in card view.
 - Click the **Provisioning > Optical Chn > Parameters** tabs.
 - Change the administrative state of the CHAN RX port to **OOS,MT (ANSI)** or **Locked,maintenance (ETSI)** for the channel related to the wavelength selected on the tunable laser.
 - Verify that the Power value of the CHAN RX port reaches the provisioned setpoint (VOA Power Ref).
- Step 5** Verify the TX band power on the west AD-xB-xx.x (west-to-east):
- Display the west AD-xB-xx.x card in card view.
 - Click the **Provisioning > Optical Band > Parameters** tabs.
 - Change the administrative state of the BAND TX port to **OOS,MT (ANSI)** or **Locked,maintenance (ETSI)** for the channel related to the wavelength selected on the tunable laser.
 - Verify that the BAND TX Power value is higher than the default no-power value of -30 dBm.
- Step 6** Verify the west 4MD-xx.x (west-to-east):
- Display the west 4MD-xx.x card in card view.
 - Click the **Provisioning > Optical Chn > Parameters** tabs.
 - Verify that the Power value on the CHAN TX port is higher than the default no-power value of -35 dBm.
- Step 7** Verify the east 4MD-xx.x (west-to-east):
- Display the east 4MD-xx.x card in card view.

- b. Click the **Provisioning > Optical Chn > Parameters** tabs.
- c. Change the administrative state of the CHAN RX port to **OOS,MT** (ANSI) or **Locked,maintenance** (ETSI) for the channel related to the wavelength selected on the tunable laser.
- d. Verify that the Power value of the CHAN RX port reaches the provisioned setpoint (VOA Power Ref).

Step 8 Return to your originating procedure (NTP).

NTP-G49 Perform the OADM Active Node Acceptance Test on a Symmetric Node with OSC-CSM Cards

Purpose	This procedure checks the integrity of all the optical connections inside an OADM node with OSC-CSM and OPT-BST or OPT-BST-E cards installed on both the east and west sides of the shelf. Three connection types are tested: <ul style="list-style-type: none"> • Express • Pass-through • Add/Drop
Tools/Equipment	A tunable laser or a TXP_MR_10E_C card An optical power meter or optical spectrum analyzer 2 bulk attenuators (10 dB) with LC connectors
Prerequisite Procedures	Chapter 3, “Turn Up a Node”
Required/As Needed	Required
Onsite/Remote	Onsite
Security Level	Superuser



Note

Optical power measurements require either a tunable laser or a multirate transponder to generate the proper optical wavelength. If multirate transponders were installed during completion of [Chapter 3, “Turn Up a Node,”](#) they can be used for this procedure. No additional cabling changes are needed.

- Step 1** Complete the [“DLP-G46 Log into CTC” task on page 2-25](#) at the OADM node where you want to perform the acceptance test. If you are already logged in, continue with [Step 2](#).
- Step 2** From the View menu, choose **Go to Network View**.
- Step 3** Click the **Alarms** tab.
 - a. Verify that the alarm filter is not on. See the [“DLP-G128 Disable Alarm Filtering” task on page 8-28](#) as necessary.
 - b. Verify that no equipment alarms appear indicating equipment failure or other hardware problems. (Equipment alarms are indicated by an EQPT in the Alarms tab Cond column.) If equipment failure alarms appear, investigate and resolve them before continuing. Refer to the *Cisco ONS 15454 DWDM Troubleshooting Guide* for procedures.

Step 4 In node view (single-shelf mode) or multishelf view (multishelf mode), click the **Provisioning > WDM-ANS > Port Status** tabs. Verify that all statuses under Link Status are Success - Changed, Success - Unchanged, or Not Applicable. If not, complete the “[NTP-G37 Run Automatic Node Setup](#)” procedure on page 3-82.

Step 5 Check the Cisco MetroPlanner site configuration file to verify the presence of added and dropped bands (including 4 channels at 100 GHz) configured in pass-through mode in either direction.



Note Configuring a band in pass-through mode means that the band is dropped in one direction by an AD-xB-xx.x card on one side (east or west) of the node, then added by another AD-xB-x.xx card on the opposite side in the same direction. The band is not terminated inside the node.

Step 6 If no bands are configured in pass-through mode, continue with [Step 7](#). If a band is configured in pass-through mode, mark it and skip the related optical test for the express, add, and drop sections. Band pass-through connections are verified separately.

Step 7 Check the site configuration file from Cisco MetroPlanner to verify the presence of dropped or added channels configured in pass-through mode in either direction.



Note Configuring a channel in pass-through mode means that the channel is dropped in one direction by an AD-xC-xx.x card on one side (east or west) of the node, then added by another AD-xC x.xx card on the opposite side in the same direction. The channel is not terminated inside the node.

Step 8 If no channels are configured in pass-through mode, continue with [Step 9](#). If a channel is configured in pass-through mode, mark it and skip the related optical test for the express, add, and drop sections. Channel pass-through connections are verified separately.

Step 9 Create a loopback on the west OSC-CSM card by connecting the LINE TX port to the LINE RX port using a patchcord and a 10-dB bulk attenuator.

Step 10 Verify that the OSC link becomes active on the west OSC-CSM card. (The OSC termination must be already provisioned. If not, complete the “[NTP-G38 Provision OSC Terminations](#)” procedure on page 3-83.)



Note Due to the OSC signal loopback, an SDCC Termination Failure alarm might be raised.

Step 11 If the OSC link becomes active, continue with [Step 12](#). If the OSC link does not turn up, perform the following troubleshooting steps:

- a. Remove the 10-dB bulk attenuator between the LINE TX and LINE RX connection. If the OSC link becomes active, continue with [Step 12](#). If not, continue with [Step b](#).
- b. Modify the OSC Fail Low thresholds. Click the **Provisioning > Optical Line > Optics Thresholds** tabs and change the Port 6 opwrMin (minimum power) to -40 dBm.
- c. Modify the COM TX Fail Low Threshold. Change the Port 3 opwrMin (minimum power) to -30 dBm.
- d. If the OSC link turns up, continue with [Step 12](#). If it does not turn up, replace the OSC-CSM card.

Step 12 If the node has express bands or channels, complete the “[DLP-G86 Verify Express Channel Connections on an OADM Node with OSC-CSM Cards](#)” task on page 4-104. If the node does not have express bands or channels, continue with [Step 13](#).

- Step 13** If connections configured in pass-through mode are present (noted in Steps 6 and 8), complete the “[DLP-G89 Verify OADM Node Pass-Through Channel Connections](#)” task on page 4-94. If not, continue with Step 14.
- Step 14** If connections have add/drop connections, complete the “[DLP-G94 Verify Add and Drop Connections on an OADM Node with OSC-CSM Cards](#)” task on page 4-105.

Stop. You have completed this procedure.

DLP-G86 Verify Express Channel Connections on an OADM Node with OSC-CSM Cards

Purpose	This task verifies the express channel connections for an OADM node with OSC-CSM cards during a node acceptance test.
Tools/Equipment	A tunable laser or a TXP_MR_10E_C card
Prerequisite Procedures	DLP-G46 Log into CTC , page 2-25
Required/As Needed	As needed
Onsite/Remote	Onsite
Security Level	Superuser

- Step 1** If you are using a tunable laser, set the output power to a nominal value, such as –3 dBm. If not, continue with [Step 2](#).
- Step 2** Connect the tunable laser transmitter or the TXP_MR_10E_C card DWDM TX port to the LINE RX port of the east OSC-CSM card.
- Step 3** If an OPT-PRE amplifier card is installed on the east side, install a 10-dB bulk attenuator on the COM RX port.
- Step 4** Based on the Cisco MetroPlanner site configuration file, tune the tunable laser or TXP_MR_10E_C card to a wavelength (on the 100-GHz ITU-T grid) that runs on the express path of all AD-xB-xx.x and AD-xC-xx.x cards on the east-to-west and west-to-east directions. Refer to the tunable laser manufacturer’s documentation or the “[DLP-G268 Provision TXP_MR_10E_C Cards for Acceptance Testing](#)” task on page 4-4.
- Step 5** Complete the “[DLP-G80 Verify the OPT-PRE Amplifier Laser and Power](#)” task on page 4-6 for the OPT-PRE amplifier card installed on the west side.
- Step 6** If AD-xB-xx.x cards are installed on the east side, complete the “[DLP-G87 Verify the AD-xB-xx.x Output Express Power](#)” task on page 4-93 for each east side card. If not, continue with [Step 7](#).



Note If AD-xB-xx.x and AD-xC cards are both installed in one direction, the received express channels will go into the AD-xB-xx.x cards first, then into the AD-xC-xx.x cards.

- Step 7** If AD-xC-xx.x cards are installed on the east side, complete the “[DLP-G88 Verify the AD-xC-xx.x Output Express Power](#)” task on page 4-93 for each east side card. If not, continue with [Step 8](#).
- Step 8** If AD-xC-xx.x cards are installed on the west side, complete the “[DLP-G271 Verify the AD-xC-xx.x Output Common Power](#)” task on page 4-94 for each west side card. If not, continue with [Step 9](#).

- Step 9** If AD-xB-xx.x cards are installed on the west side, complete the “[DLP-G272 Verify the AD-xB-xx.x Output Common Power](#)” task on page 4-94 for each west side card. If not, continue with [Step 10](#).
- Step 10** Complete the “[DLP-G83 Verify the OSC-CSM Power on OADM Nodes](#)” task on page 4-105 for the OSC-CSM card installed on the west side.
- Step 11** Complete the “[DLP-G80 Verify the OPT-PRE Amplifier Laser and Power](#)” task on page 4-6 for the OPT-PRE card installed on the east side.
- Step 12** Repeat Steps [6](#) through [9](#) for the AD-xB-xx.x and AD-xC-xx.x cards along the west-to-east direction.
- Step 13** Complete the “[DLP-G83 Verify the OSC-CSM Power on OADM Nodes](#)” task on page 4-105 for the OSC-CSM card installed on the west side.
- Step 14** Return to your originating procedure (NTP).

DLP-G83 Verify the OSC-CSM Power on OADM Nodes

Purpose	This task verifies the OSC-CSM card power on OADM nodes.
Tools/Equipment	None
Prerequisite Procedures	DLP-G46 Log into CTC, page 2-25
Required/As Needed	As needed
Onsite/Remote	Onsite or remote
Security Level	Superuser

- Step 1** Display the OSC-CSM card in card view.
- Step 2** Click the **Provisioning > Optical Line > Parameters** tabs.
- Step 3** Verify that the Power value for Port 3 is higher than the default no-power value of –30 dBm. The calculated expected power value for Port 3 is:
Pout COM TX of last AD-xy-xx.x – IL02 OSC-CSM (COM RX > LINE TX) – 10 dB (bulk attenuator)
- Step 4** Double-check the value.
-  **Note** Actual output power is affected by many factors. Always consider the calculated expected power to be a general guideline and not a precise value.
- Step 5** Return to your originating procedure (NTP).

DLP-G94 Verify Add and Drop Connections on an OADM Node with OSC-CSM Cards

Purpose	This task verifies the add and drop channel connections for an OADM node with OSC-CSM cards installed.
Tools/Equipment	A tunable laser or a TXP_MR_10E_C card

Prerequisite Procedures [DLP-G46 Log into CTC, page 2-25](#)

Required/As Needed As needed

Onsite/Remote Onsite

Security Level Superuser

-
- Step 1** Based on the Cisco MetroPlanner site configuration file, tune the tunable laser or TXP_MR_10E_C card to a wavelength (belonging to the 100-GHz ITU-T grid) of the channel running on the first add path of the first west AD-xC-xx.x or west 4MD-xx.x card on the east-to-west direction. Refer to the tunable laser manufacturer's documentation or the [“DLP-G268 Provision TXP_MR_10E_C Cards for Acceptance Testing” task on page 4-4](#).
- Step 2** Connect the tunable laser transmitter or the TXP_MR_10E_C card DWDM TX port to the corresponding 15xx.x RX port (on the card front panel) of the west AD-xC-xx.x or 4MD-xx.x card.
- Step 3** Verify the west AD-xC-xx.x or 4MD-xx.x (east-to-west):
- Display the west AD-xC-xx.x or 4MD-xx.x card in card view.
 - Click the **Provisioning > Optical Chn > Parameters** tabs.
 - Change the administrative state of the CHAN RX port to **OOS,MT** (ANSI) or **Locked,maintenance** (ETSI) for the channel related to the wavelength selected on the tunable laser.
 - Verify that the Power value of the CHAN RX port reaches the provisioned setpoint (VOA Power Ref).
- Step 4** Complete the [“DLP-G80 Verify the OPT-PRE Amplifier Laser and Power” task on page 4-6](#) on the west OPT-PRE amplifier to verify that the added wavelength turns on the laser.
- Step 5** If the add connection uses a 4MD-xx.x card, continue with [Step 6](#). If the add connection uses an AD-xC-xx.x card, move to [Step 10](#).
- Step 6** Verify the west AD-xB-xx.x:
- Display the west AD-xB-xx.x card in card view.
 - Click the **Provisioning > Optical Band > Parameters** tabs.
 - Change the administrative state of the BAND TX port to **OOS,MT** (ANSI) or **Locked,maintenance** (ETSI) for the channel related to the wavelength selected on the tunable laser.
 - Verify that the Power value of the BAND TX port is higher than the default no-power value of -30 dBm.
- Step 7** Display the related AD-xB-xx.x card (west-to-east direction) in card view.
- Step 8** Change the administrative state of the drop BAND TX port related to the wavelength selected on the tunable laser to **OOS,MT** (ANSI) or **Locked,maintenance** (ETSI).
- Step 9** (Optional) Connect a power meter to the proper 15xx.xs TX port on the front panel (the dual port compared with the port where the tunable laser is connected). Verify that the physical optical power value from that port is consistent with the value displayed on the Provisioning > Optical Chn > Parameters tab for the proper CHAN TX power value, +/- 0.5 dB.
- Step 10** Verify the west AD-xC-xx.x (west-to-east) card:
- Display the west AD-xC-xx.x card in card view.
 - Click the **Provisioning > Optical Chn > Parameters** tabs.
 - Verify that the Power value of the CHAN TX port is higher than the default no-power value of -35 dBm.
 - Display the east AD-xC-xx.x card in card view.

- e. Click the **Provisioning > Optical Chn > Parameters** tabs.
- f. Verify that the power value for the CHAN TX port is higher than the default no-power value of -35 dBm.
- g. If the AD-xC-xx.x card is an AD-4C-xx.x card, a VOA (applied to all four channels) is installed along the drop path and needs to be activated in Step h.
- h. Change the administrative state of the CHAN TX port related to the wavelength selected on the tunable laser to **OOS,MT** (ANSI) or **Locked,maintenance** (ETSI). Click **Apply**.
- i. Perform the output power check.

- Step 11** (Optional) Connect a power meter to the proper 15xx.xx TX port on the front panel (the dual port compared with the port where the tunable laser is connected). Verify that the physical optical power value from that port is consistent with the value on Provisioning > Optical Chn > Parameters tab for the proper CHAN TX power value, ± 0.5 dB.
- Step 12** Repeat Steps 10 through 11 for all add paths of any west AD-xC-xx.x cards along the east-to-west direction.
- Step 13** Remove the loopback on the west OSC-CSM card.
- Step 14** In node view (single-shelf mode) or multishelf view (multishelf mode), click the **Provisioning > WDM-ANS > Port Status** tabs.
- Step 15** Click **Launch ANS**.
- Step 16** Create a loopback on the east OSC-CSM card by connecting the OSC-CSM LINE RX and LINE TX ports using a patchcord and 10-dB bulk attenuator.
- Step 17** Verify that the OSC link becomes active on the west OSC-CSM card. (The OSC termination must be already provisioned. If not, complete the [“NTP-G38 Provision OSC Terminations” procedure on page 3-83.](#))



Note Due to the OSC signal loopback, an SDCC Termination Failure alarm might be raised.

- Step 18** If the OSC link becomes active, continue with Step 19. If the OSC link does not turn up, perform the following troubleshooting steps:
- a. Remove the 10-dB bulk attenuator between the LINE TX and LINE RX connection. If the OSC link becomes active, continue with Step 19. If not, continue with Step b.
 - b. Modify the OSC Fail Low thresholds. Click the **Provisioning > Optical Line > Optics Thresholds** tabs and change the Port 6 opwrMin (minimum power) to -40 dBm.
 - c. Modify the COM TX Fail Low Threshold. Change the Port 3 opwrMin (minimum power) to -30 dBm.
 - d. If the OSC link turns up, continue with Step 19. If it does not turn up, replace the OSC-CSM card.
- Step 19** Check the site configuration file from Cisco MetroPlanner and identify the wavelength (belonging to the 100 GHz ITU-T grid) of the channel running on the first add path of the first AD-xC-xx.x or 4MD-xx.x card on the west-to-east direction.
- Step 20** Connect the tunable laser to the correspondent 15xx.x RX port (on the card front panel) of the east AD-xC-xx.x or east 4MD-xx.x card.
- Step 21** Repeat Steps 3 through 20, applying the steps to the east-to-west direction.
- Step 22** Restore the default administrative state (IS,AINS/Unlocked,automaticInService) on all the ports previously set to **OOS,MT** (ANSI) or **Locked,maintenance** (ETSI).

- Step 23** Complete the “[NTP-G37 Run Automatic Node Setup](#)” procedure on page 3-82 to recover the correct node configuration.
- Step 24** Return to your originating procedure (NTP).

NTP-G50 Perform the OADM Passive Node Acceptance Test on a Symmetric Node with OSC-CSM Cards

Purpose	This procedure checks the integrity of all the optical connections inside an OADM node with OSC-CSM cards and no OPT-BST or OPT-BST-E cards installed on the east and west sides of the shelf. Three connection types are tested: <ul style="list-style-type: none"> • Express • Pass-through • Add/Drop
Tools/Equipment	A tunable laser or a TXP_MR_10E_C card An optical power meter or optical spectrum analyzer 2 bulk attenuators (10 dB) with LC connectors
Prerequisite Procedures	Chapter 3, “Turn Up a Node”
Required/As Needed	Required
Onsite/Remote	Onsite
Security Level	Superuser



Note

Optical power measurements require either a tunable laser or a multirate transponder to generate the proper optical wavelength. If multirate transponders were installed during completion of [Chapter 3, “Turn Up a Node,”](#) they can be used for this procedure. No additional cabling changes are needed.

- Step 1** Complete the “[DLP-G46 Log into CTC](#)” task on page 2-25 at the OADM node where you want to perform the acceptance test. If you are already logged in, continue with [Step 2](#).
- Step 2** From the View menu, choose **Go to Network View**.
- Step 3** Click the **Alarms** tab.
- Verify that the alarm filter is not on. See the “[DLP-G128 Disable Alarm Filtering](#)” task on page 8-28 as necessary.
 - Verify that no equipment alarms appear indicating equipment failure or other hardware problems. (Equipment alarms are indicated by an EQPT in the Alarms tab Cond column.) If equipment failure alarms appear, investigate and resolve them before continuing. Refer to the *Cisco ONS 15454 DWDM Troubleshooting Guide* for procedures.
- Step 4** In node view (single-shelf mode) or multishelf view (multishelf mode), click the **Provisioning > WDM-ANS > Port Status** tabs. Verify that all statuses under Link Status are Success - Changed, Success - Unchanged, or Not Applicable. If not, complete the “[NTP-G37 Run Automatic Node Setup](#)” procedure on page 3-82.

- Step 5** Check the Cisco MetroPlanner site configuration file to verify the presence of a dropped or added bands (including 4 channels at 100 GHz) configured in pass-through mode in either direction.



Note Configuring a band in pass-through mode means that the band is dropped in one direction by an AD-xB-xx.x card on one side (east or west) of the node, then added by another AD-xB x.xx card on the opposite side in the same direction. The band is not terminated inside the node.

- Step 6** If no bands are configured in pass-through mode, continue with [Step 7](#). If a band is configured in pass-through mode, mark it and skip the related optical test for the express, add, and drop sections. Band pass-through connections are verified separately.

- Step 7** Check the site configuration file from Cisco MetroPlanner to verify the presence of dropped or added channels configured in pass-through mode in either direction.



Note Configuring a channel in pass-through mode means that the channel is dropped in one direction by an AD-xC-xx.x card on one side (east or west) of the node, then added by another AD-xC-x.xx card on the opposite side in the same direction. The channel is not terminated inside the node.

- Step 8** If no channels are configured in pass-through mode, continue with [Step 9](#). If a channel is configured in pass-through mode, mark it and skip the related optical test for the express, add, and drop sections. Channel pass-through connections are verified separately.

- Step 9** Create a loopback on the west OSC-CSM card by connecting the LINE TX port to the LINE RX port using a patchcord and 10-dB bulk attenuator.

- Step 10** Verify that the OSC link becomes active on the west OSC-CSM card. (The OSC termination must be already provisioned. If not, complete the [“NTP-G38 Provision OSC Terminations” procedure on page 3-83.](#))



Note Due to the OSC signal loopback, an SDCC Termination Failure alarm might be raised.

- Step 11** If the OSC link becomes active, continue with [Step 12](#). If the OSC link does not turn up, perform the following troubleshooting steps:
- Remove the 10-dB bulk attenuator between the LINE TX and LINE RX connection. If the OSC link becomes active, continue with [Step 12](#). If not, continue with [Step b](#).
 - Modify the OSC Fail Low thresholds. Click the **Provisioning > Optical Line > Optics Thresholds** tabs and change the Port 6 opwrMin (minimum power) to -40 dBm.
 - Modify the COM TX Fail Low Threshold. Change the Port 3 opwrMin (minimum power) to -30 dBm.
 - If the OSC link turns up, continue with [Step 12](#). If it does not turn up, replace the OSC-CSM card.
- Step 12** If the node has express bands or channels, complete the [“DLP-G86 Verify Express Channel Connections on an OADM Node with OSC-CSM Cards” task on page 4-104](#). If the node does not have express bands or channels, continue with [Step 13](#).
- Step 13** If connections configured in pass-through mode are present (noted in [Steps 5 and 7](#)), complete the [“DLP-G89 Verify OADM Node Pass-Through Channel Connections” task on page 4-94](#). If not, continue with [Step 14](#).
- Step 14** If connections have add/drop connections, complete the [“DLP-G94 Verify Add and Drop Connections on an OADM Node with OSC-CSM Cards” task on page 4-105](#).

Stop. You have completed this procedure.

DLP-G82 Verify the OSC-CSM Power

Purpose	This task verifies the OSC-CSM card power.
Tools/Equipment	None
Prerequisite Procedures	DLP-G46 Log into CTC, page 2-25
Required/As Needed	As needed
Onsite/Remote	Onsite or remote
Security Level	Superuser

- Step 1** Display the OSC-CSM card in card view.
- Step 2** Click the **Provisioning > Optical Line > Parameters** tabs.
- Step 3** If an OPT-PRE is not installed on the same side of the shelf as the OSC-CSM, verify that the Port 3 Power value is higher than the default no-power value of -30 dBm. If the power is not higher than -30 dBm, contact your next level of support.
- Step 4** Return to your originating procedure (NTP).
-



Provision Transponder and Muxponder Cards

This chapter explains how to provision transponder (TXP) and muxponder (MXP) cards. The provisioning must be performed before you provision the dense wavelength division multiplexing (DWDM) network and create circuits.



Note

Unless otherwise specified, “ONS 15454” refers to both ANSI and ETSI shelf assemblies.

Before You Begin

Before performing any of the following procedures, investigate all alarms and clear any trouble conditions. Refer to the *Cisco ONS 15454 DWDM Troubleshooting Guide* as necessary.



Caution

Provisioning TXPs and MXPs can be service affecting. You should make all changes during a scheduled maintenance window.

This section lists the chapter procedures (NTPs). Turn to a procedure for applicable tasks (DLPs).

1. [NTP-G128 Manage Pluggable Port Modules, page 5-2](#)—Complete this procedure to provision a multirate pluggable port module (PPM), provision or change the optical line rate of a PPM, or delete a PPM. PPMs provide the fiber interface to the TXP and MXP cards. With the exception of the TXP_MR_10G card, all TXPs and MXPs accept PPMs.
2. [NTP-G33 Create a Y-Cable Protection Group, page 5-14](#)—Complete this procedure, as needed, for TXP and MXP cards that will be protected with Y-cable protection.
3. [NTP-G98 Provision the 2.5G Multirate Transponder Card Line Settings and PM Parameter Thresholds, page 5-17](#)—As needed, complete this procedure to change the transmission settings for TXP_MR_2.5G and TXPP_MR_2.5G cards.
4. [NTP-G96 Provision the 10G Multirate Transponder Card Line Settings, PM Parameters, and Thresholds, page 5-37](#)—As needed, complete this procedure to change the transmission settings for TXP_MR_10G, TXP_MR_10E, TXP_MR_10E_C, and TXP_MR_10E_L cards.
5. [NTP-G97 Modify the 4x2.5G Muxponder Card Line Settings and PM Parameter Thresholds, page 5-58](#)—As needed, complete this procedure to change the transmission settings for MXP_2.5G_10G, MXP_2.5G_10E, MXP_2.5G_10E_C, and MXP_2.5G_10E_L cards.
6. [NTP-G99 Modify the 2.5G Data Muxponder Card Line Settings and PM Parameter Thresholds, page 5-79](#)—As needed, complete this procedure to change the transmission settings for MXP_MR_2.5G and MXPP_MR_2.5G cards.

7. [NTP-G148 Modify the 10G Data Muxponder Card Line Settings and PM Parameter Thresholds, page 5-97](#)—As needed, complete this procedure to change the transmission settings for MXP_MR_10DME_C and MXP_MR_10DME_L cards.
8. [NTP-G162 Change the TXP or MXP ALS Maintenance Settings, page 5-117](#)—As needed, complete this procedure to change a TXP or MXP card automatic laser shutdown settings.

NTP-G128 Manage Pluggable Port Modules

Purpose	Complete this procedure to provision a multirate PPM, provision the optical line rate of a multirate PPM, or delete a single-rate or multirate PPM.
Tools/Equipment	None
Prerequisite Procedures	NTP-G32 Install the Transponder and Muxponder Cards, page 3-50 DLP-G63 Install an SFP or XFP, page 3-52
Required/As Needed	As needed
Onsite/Remote	Onsite or remote
Security Level	Provisioning or higher



Note

If a single-rate PPM is installed, the PPM screen will autoprovision and no further steps are necessary.



Note

The hardware device that plugs into a TXP or MXP card faceplate to provide a fiber interface to the card is called a Small Form-factor Pluggable (SFP or XFP). In Cisco Transport Controller (CTC), SFPs and XFPs are called PPMs. SFPs/XFPs are hot-swappable input/output devices that plug into a TXP, MXP, or line card port to link the port with the fiber-optic network. For more information about SFPs and XFPs, refer “Hardware Specifications” chapter in the *Cisco ONS 15454 DWDM Reference Manual*, or the *Installing GBIC, SFP and XFP Optics Modules in Cisco ONS 15454, 15454 SDH, 15327, 15600, and 15310-CL Platforms* document available in the ONS 15454 production documentation website on www.cisco.com.

- Step 1** Complete the “[DLP-G46 Log into CTC](#)” task on [page 2-25](#) to log into an ONS 15454 on the network. If you are already logged in, continue with Step 2.
- Step 2** Click the **Alarms** tab:
 - a. Verify that the alarm filter is not turned on. See the “[DLP-G128 Disable Alarm Filtering](#)” task on [page 8-28](#) as necessary.
 - b. Verify that no unexplained conditions appear on the network. If unexplained conditions appear, resolve them before continuing. Refer to the *Cisco ONS 15454 DWDM Troubleshooting Guide*.
- Step 3** If you are provisioning a MXP_MR_2.5G and MXPP_MR_2.5G card, complete the “[DLP-G235 Change the 2.5G Data Muxponder Card Mode](#)” task on [page 5-3](#). If not, continue with Step 4
- Step 4** If you are provisioning a MXP_MR_10DME_C and MXP_MR_10DME_L card, complete the “[DLP-G332 Change the 10G Data Muxponder Port Mode](#)” task on [page 5-4](#). If not, continue with Step 5.
- Step 5** Complete the “[DLP-G277 Provision a Multirate PPM](#)” task on [page 5-6](#). If you preprovisioned a multirate PPM ([DLP-G273 Preprovision an SFP or XFP Slot, page 3-53](#)), skip this step and continue with Step 6.

- Step 6** If you are provisioning an IBM ETR_CLO (External Time Reference – Control Link Oscillator) or InterSystem Coupling Link (ISC) service on the PPM, complete “[DLP-G274 Verify Topologies for ETR_CLO and ISC Services](#)” task on page 5-7. Otherwise, continue with [Step 7](#).
- Step 7** Complete the “[DLP-G278 Provision the Optical Line Rate](#)” task on page 5-9 to assign a line rate to a TXP or MXP port.
- Step 8** If you need to delete a PPM at any point in this procedure, complete the “[DLP-G280 Delete a PPM](#)” task on page 5-12.
- Stop. You have completed this procedure.**
-

DLP-G235 Change the 2.5G Data Muxponder Card Mode

Purpose	This task changes the card mode for MXP_MR_2.5G and MXPP_MR_2.5G muxponder cards. The card mode determines what PPMs can be provisioned for the card.
Tools/Equipment	None
Prerequisite Procedures	DLP-G46 Log into CTC, page 2-25
Required/As Needed	As needed
Onsite/Remote	Onsite or remote
Security Level	Provisioning or higher

- Step 1** Click the **Provisioning > Line > SONET (ANSI) or SDH (ETSI)** tabs.
- Step 2** Locate the Trunk port table row and verify that the Service State column value is OOS-MA,DSBLD (ANSI) or Locked-enabled,disabled (ETSI). If yes, continue with [Step 3](#). If not, complete the following steps:
- Click the **Admin State** table cell and choose **OOS,MT (ANSI) or Locked,Maintenance (ETSI)**.
 - Click **Apply**, then **Yes**.
- Step 3** In node view (single-shelf mode) or shelf view (multishelf view), double-click the MXP_MR_2.5G or MXPP_MR_2.5G card where you want to change the card settings.
- Step 4** Click the **Provisioning > Card** tabs.
- Step 5** Modify any of the settings described in [Table 5-1](#).

Table 5-1 2.5G Data Muxponder Card Settings

Parameter	Description	Options
Card Mode	Sets the mode of operation that determines what PPMs can be provisioned. (PPMs are provisioned in the “ DLP-G277 Provision a Multirate PPM ” task on page 5-6.)	<p>Chose one of the following:</p> <ul style="list-style-type: none"> FC-GE—Choose this option if you will provision any of the following PPM port rates: FC1G (Ports 1-1 and 2-1 only), FC2G (Port 1-1 only), FICON1G (Ports 1-1 and 2-1 only), FICON2G (Port 1-1 only), and ONE_GE (Ports 1-1 through 8-1). Mixed—Choose this option if you will provision any of the following PPM port rates: FC1G and ONE_GE (Port 1-1 only), ESCON (Ports 5-1 through 8-1 only) ESCON—Choose this option if you will provision the ESCON PPM on Ports 1-1 through 8-1.
Tunable Wavelengths	(Display only) Shows the supported wavelengths of the trunk port after the card is installed in the format: <i>first wavelength-last wavelength-frequency spacing-number of supported wavelengths</i> . For example, 1529.55nm-1561.83nm-50gHz-82.	—

Step 6 Click **Apply**.

Step 7 Return to your originating procedure (NTP).

DLP-G332 Change the 10G Data Muxponder Port Mode

Purpose	This task changes the port mode for the MXP_MR_10DME_C and MXP_MR_10DME_L muxponder cards. The port mode determines what PPMs can be provisioned on the MXP_MR_10DME_C and MXP_MR_10DME_L ports.
Tools/Equipment	None
Prerequisite Procedures	DLP-G46 Log into CTC , page 2-25
Required/As Needed	As needed
Onsite/Remote	Onsite or remote
Security Level	Provisioning or higher



Note

To change the card mode, ports within the port group must be OOS (out-of-service). Ports in the other port group do not need to be OOS if you are not changing its card mode.

- Step 1** In node view (single-shelf mode) or shelf view (multishelf view), double-click the MXP_MR_10DME_C or MXP_MR_10DME_L card where you want to change the card settings.
- Step 2** Click the **Provisioning > Card** tabs.
- Step 3** Modify any of the settings described in [Table 5-2](#).



Note The PPM port rates are provisioned in the “[DLP-G277 Provision a Multirate PPM](#)” task on [page 5-6](#).

Table 5-2 10G Data Muxponder Card Settings

Parameter	Description	Options
Port 1-4 Mode	Sets the mode of operation for Ports 1-1 through 4-1.	<p>Chose one of the following:</p> <ul style="list-style-type: none"> FC-GE_ISC—Choose this option if you will provision any of the following PPM port rates: FC1G (Ports 1-1 through 4-1), FC2G (Ports 1-1 and 3-1 only), FICON1G (Ports 1-1 through 4-1), FICON2G (Ports 1-1 and 3-1 only), ONE_GE (Ports 1-1 through 4-1), ISC3 COMPAT (Ports 1-1 through 4-1), ISC3 PEER 1G (Ports 1-1 through 4-1), and ISC3 PEER 2G (Ports 1-1 and 3-1 only). FC4G—Choose this option if you will provision an FC4G or FICON4G PPM (Port 1-1 only).
Port 5-8 Mode	Sets the mode of operation for Ports 5-1 through 8-1.	<p>Chose one of the following:</p> <ul style="list-style-type: none"> FC-GE_ISC—choose this option if you will provision any of the following PPM port rates: FC1G (Ports 5-1 through 8-1), FC2G (Ports 5-1 and 7-1 only), FICON1G (Ports 5-1 through 8-1), FICON2G (Ports 5-1 and 7-1 only), ONE_GE (Ports 5-1 through 8-1), ISC3 COMPAT (Ports 5-1 through 8-1), ISC3 PEER 1G (Ports 5-1 through 8-1), and ISC3 PEER 2G (Ports 5-1 and 7-1 only). FC4G—choose this option if you will provision an FC4G or FICON4G PPM port rate (Port 5-1 only).
Tunable Wavelengths (Display only)	Shows the wavelengths supported by the card. Wavelengths appear after a physical card is installed.	If a MXP_MR_10DME_C card is installed, the 32 C-band wavelengths are displayed. If the MXP_MR_10DME_L card is installed, the 32 L-band wavelengths are displayed.

- Step 4** Click **Apply**.
- Step 5** Return to your originating procedure (NTP).



Note Loopbacks on MXP-MR-10DME are not applicable when Fiber Channel switches are present.



Note If the Fiber Channel switch version is not present then the Distance Extension settings are not supported.

DLP-G277 Provision a Multirate PPM

Purpose	This task provisions a multirate TXP/MXP PPM.
Tools/Equipment	None
Prerequisite Procedures	DLP-G46 Log into CTC, page 2-25
Required/As Needed	As needed
Onsite/Remote	Onsite or remote
Security Level	Provisioning or higher



Note If the PPM was preprovisioned using the “[DLP-G273 Preprovision an SFP or XFP Slot](#)” task on [page 3-53](#) this task is unnecessary, unless the PPM has an Out-of-Service and Autonomous Management, Unassigned (OOS-AUMA,UAS) (ANSI) or unlocked-disabled, unassigned (ETSI) service state.

- Step 1** In node view (single-shelf mode) or shelf view (multishelf view), double-click the TXP or MXP card where you want to provision PPM settings.
- Step 2** If this is the first PPM provisioned for the TXP/MXP card, complete the following steps. If not, continue with [Step 3](#).
- Click the **Provisioning > Line > SONET** (ANSI) or **SDH** (ETSI) tabs.
 - Locate the Trunk port table row and verify that the Service State column value is OOS-MA,DSBLD (ANSI) or Locked-enabled,disabled (ETSI). If yes, continue with [Step 3](#). If not, continue with Step 3.
 - Click the **Admin State** table cell and choose **OOS,MT** (ANSI) or **Locked,Maintenance** (ETSI).
 - Click **Apply**, then **Yes**.
- Step 3** Click the **Provisioning > Pluggable Port Modules** tabs.
- Step 4** In the Pluggable Port Modules area, click **Create**. The Create PPM dialog box appears.
- Step 5** In the Create PPM dialog box, complete the following:
- PPM—Choose the slot number where the SFP is installed from the drop-down list.
 - PPM Type—Choose the number of ports supported by your SFP from the drop-down list. If only one port is supported, **PPM (1 port)** is the only option.
- Step 6** Click **OK**. The newly created port appears in the Pluggable Port Modules area. The row in the Pluggable Port Modules area turns white and the Actual Equipment Type column lists the equipment name.
- Step 7** If you want to provision a PPM on another port, repeat Steps [4](#) through [6](#). If not, continue with [Step 8](#).

Step 8 Return to your originating procedure (NTP).

DLP-G274 Verify Topologies for ETR_CLO and ISC Services

Purpose	This task verifies that the DWDM network topology can support the IBM ETR_CLO and ISC services.
Tools/Equipment	Cisco MetroPlanner site plan.
Prerequisite Procedures	None
Required/As Needed	As needed
Onsite/Remote	Onsite or remote
Security Level	Provisioning or higher

Step 1 Display your site plan in Cisco MetroPlanner.

Step 2 Verify that the topology where you plan to run the ETR_CLO or ISC service is one of the topologies that supports these services:

- Single span—Two terminal sites with no intermediate sites in between and one of the following sets of cards installed:
 - 32MUX-O and 32DMX-O cards
 - 32WSS and 32DMX cards
 - 32WSS and 32-DMX-O cards

Figure 5-1 shows a single-span topology as displayed in Cisco MetroPlanner.

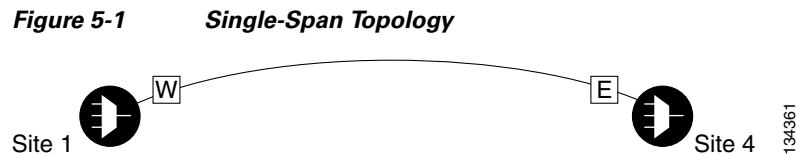

- Point-to-Point—Two terminal sites with one of the following sets of cards installed:
 - 32MUX-O and 32DMX-O cards
 - 32WSS and 32DMX cards
 - 32WSS and 32-DMX-O cards

Line amplifiers can be installed between the terminal sites, but intermediate (traffic terminating) sites cannot be installed. Figure 5-2 shows a point-to-point topology as shown in Cisco MetroPlanner.

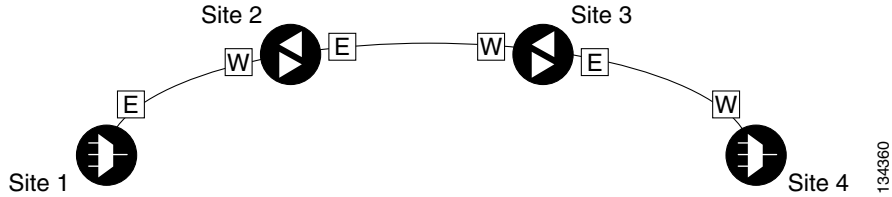
Figure 5-2 Point-to-Point Topology

- Two hubs—Two hub nodes in a ring with one of the following sets of cards installed:
 - 32MUX-O and 32DMX-O cards
 - 32WSS and 32DMX cards
 - 32WSS and 32-DMX-O cards

Line amplifiers can be installed between the hubs. [Figure 5-3](#) shows two hub nodes with no line amplifier nodes installed. [Figure 5-4](#) shows two hub nodes with line amplifier nodes installed.

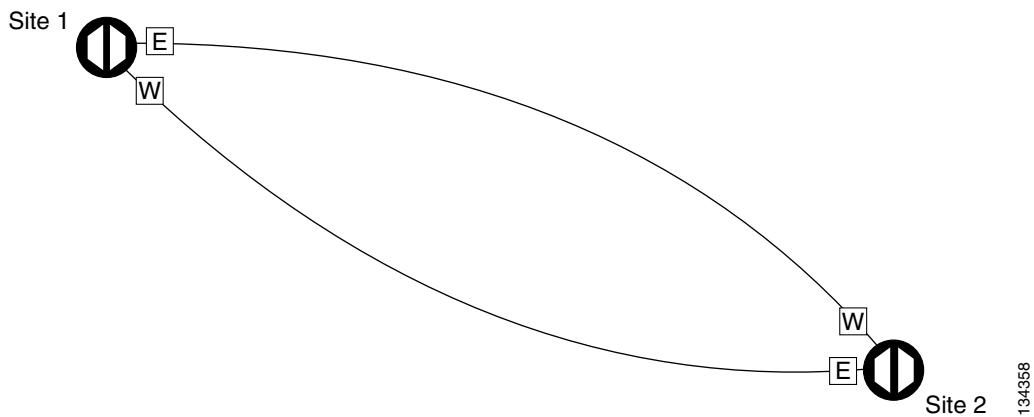
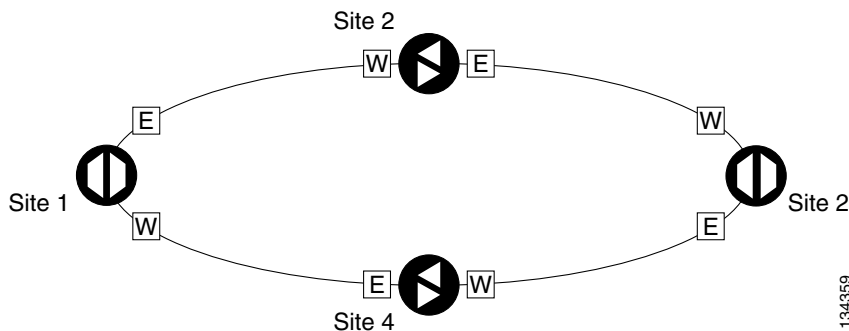
Figure 5-3 Hubs with No Line Amplifiers**Figure 5-4** Hubs with Line Amplifiers

Step 3 Return to your originating procedure (NTP).

DLP-G278 Provision the Optical Line Rate

Purpose	This task provisions the line rate on a TXP/MXP multirate PPM.
Tools/Equipment	None
Prerequisite Procedures	DLP-G46 Log into CTC, page 2-25 DLP-G277 Provision a Multirate PPM, page 5-6 DLP-G274 Verify Topologies for ETR_CLO and ISC Services, page 5-7 , if you are provisioning an ETR_CLO service.
Required/As Needed	Required
Onsite/Remote	Onsite or remote
Security Level	Provisioning or higher



Note Single-rate PPMs do not need to be provisioned.

- Step 1** In node view (single-shelf mode) or shelf view (multishelf view), double-click the TXP or MXP card where you want to provision PPM ports. If the data rate that you are provisioning is DV-6000, HDTV, ESCON, SDI/D1 Video, ISC-3 (all cards except the MXP_MR_10DME_C or MXP_MR_10DME_L), or ETR_CLO, complete the following steps. Otherwise, continue with [Step 2](#).
- Click the **Provisioning > OTN > OTN Lines** tabs.
 - In the G.709 OTN field, choose **Disable**.
 - In the FEC field, choose **Disable**.
 - Click **Apply**.
- Step 2** Click the **Provisioning > Pluggable Port Modules** tabs.
- Step 3** In the Pluggable Ports area, click **Create**. The Create Port dialog box appears.
- Step 4** In the Create Port dialog box, complete the following:
- Port—Choose the PPM number and port number from the drop-down list. The first number indicates the PPM in the Pluggable Port Modules area, and the second number indicates the port number on the PPM. For example, the first PPM with one port displays as 1-1 and the second PPM with one port displays as 2-1. The PPM number can be 1 to 4, but the port number is always 1.
 - Port Type—Choose the type of port from the drop-down list. The port type list displays the supported port rates on your PPM. See [Table 5-3 on page 5-10](#) for definitions of the supported rates on the TXP or MXP card.
- Step 5** Click **OK**. The row in the Pluggable Ports area turns light blue until the actual SFP is installed, and then the row turns white.
If the optical parameter values differ from the NE Default settings, change the port state to In-Service (for ANSI) or Unlocked (for ETSI) to synchronize the values with the NE Default settings.
- Step 6** Repeat Steps [3](#) through [5](#) to configure the rest of the port rates as needed.

Table 5-3 PPM Port Types

Card	Port Type
TXP_MR_2.5G TXPP_MR_2.5G	<ul style="list-style-type: none"> • OC-3/STM1—155 Mbps • OC-12/STM4—622 Mbps • OC-48/STM16—2.48 Gbps • ONE_GE—One Gigabit Ethernet 1.125 Gbps • ESCON—Enterprise System Connection 200 Mbps (IBM signal) • DV6000—Proprietary signal from video vendor • SDI_D1_VIDEO—Serial Digital Interface and Digital Video signal type 1 • HDTV—High Definition Television • PASS-THRU—Not specified • FC1G—Fibre Channel 1.06 Gbps • FC2G—Fibre Channel 2.125 Gbps • FICON1G—Fiber connectivity 1.06 Gbps (IBM signal) • FICON2G—Fiber connectivity 2.125 Gbps (IBM signal) • ETR_CLO—External Time Reference–Control Link Oscillator • ISC compat—InterSystem Coupling Link 1 (ISC1) • ISC peer—InterSystem Coupling Link 3 (ISC3)
MXP_2.5G_10G MXP_2.5G_10E MXP_2.5G_10E_C MXP_2.5G_10E_L	<ul style="list-style-type: none"> • OC-48/STM16—2.48 Gbps
TXP_MR_10G ¹	<ul style="list-style-type: none"> • SONET (OC-192)/SDH (STM-64) including 10G Ethernet WAN Phy • 10G Ethernet LAN Phy
TXP_MR_10E TXP_MR_10E_C TXP_MR_10E_L	<ul style="list-style-type: none"> • SONET (OC-192)/SDH (STM-64) including 10G Ethernet WAN Phy—10 Gbps • 10G Ethernet LAN Phy—10 Gbps Ethernet • 10G Fibre Channel—10 Gbps Fibre Channel

Table 5-3 PPM Port Types (continued)

Card	Port Type
MXP_MR_2.5G MXPP_MR_2.5G	<p>If the card mode is FC_GE:</p> <ul style="list-style-type: none"> • FC1G ISL—Fibre Channel 1.06 Gbps (Ports 1-1 and 2-1) • FC2G ISL—Fibre Channel 2.125 Gbps (Port 1-1 only) • FICON1G ISL—Fiber connectivity 1.06 Gbps (IBM signal) (Ports 1-1 and 2-1) • FICON2G ISL—Fiber connectivity 2.125 Gbps (IBM signal) (Port 1-1 only) • ONE_GE—One Gigabit Ethernet 1.125 Gbps (Ports 1-1 and 2-1 only) <p>If the card mode is Mixed:</p> <ul style="list-style-type: none"> • FC1G ISL—Fibre Channel 1.06 Gbps (Port 1-1 only) • FICON1G ISL—Fiber connectivity 1.06 Gbps (IBM signal) (Port 1-1 only) • ONE_GE—One Gigabit Ethernet 1.125 Gbps (Port 1-1 only) • ESCON—Enterprise System Connection 200 Mbps (IBM signal) (Ports 5-1 through 8-1) <p>If the card mode is ESCON:</p> <ul style="list-style-type: none"> • ESCON—Enterprise System Connection 200 Mbps (IBM signal) (Ports 1-1 through 8-1)

Table 5-3 PPM Port Types (continued)

Card	Port Type
MXP_MR_10DME_C MXP_MR_10DME_L	<p>If the port mode is FC_GE_ISC:</p> <ul style="list-style-type: none"> FC1G—Fibre Channel 1.06 Gbps (Ports 1-1 through 8-1) FC2G—Fibre Channel 2.125 Gbps (Ports 1-1, 3-1, 5-1, and 7-1 only; ports are not available if the port that follows—2-1, 4-1, 6-1, or 8-1—has a PPM provisioned.) FICON1G—Fiber connectivity 1.06 Gbps (IBM signal) (Ports 1-1 through 8-1) FICON2G—Fiber connectivity 2.125 Gbps (IBM signal) (Ports 1-1, 3-1, 5-1, and 7-1 only; ports are not available if the port that follows—2-1, 4-1, 6-1, or 8-1—has a PPM provisioned.) ONE_GE—One Gigabit Ethernet 1.125 Gbps (Ports 1-1 through 8-1) ISC COMPAT (Ports 1-1 through 8-1) ISC3 PEER 1G (Ports 1-1 through 8-1) ISC3 PEER 2G (Ports 1-1, 3-1, 5-1, and 7-1 only; ports are not available if the port that follows—2-1, 4-1, 6-1, or 8-1—has a PPM provisioned.) <p>If the port mode is FC4G:</p> <ul style="list-style-type: none"> FC4G—Fibre Channel 4.25 Gbps (Ports 1-1 or 5-1 only; ports are not available if any of the three ports that follow has a PPM provisioned.) FICON4G—Fiber connectivity 4.25 Gbps (IBM signal) (Ports 1-1 or 5-1 only; ports are not available if any of the three ports that follow has a PPM provisioned.)

1. Provisioned on the Data Rate Selection tab.

Step 7 Return to your originating procedure (NTP).

DLP-G280 Delete a PPM

Purpose	This task deletes PPM provisioning for SFPs or XFPs installed on TXP or MXP cards.
Tools/Equipment	None
Prerequisite Procedures	DLP-G63 Install an SFP or XFP, page 3-52 or DLP-G273 Preprovision an SFP or XFP Slot, page 3-53 DLP-G46 Log into CTC, page 2-25
Required/As Needed	As needed

Onsite/Remote	Onsite or remote
Security Level	Provisioning or higher



Note Before deleting a PPM, delete the PPM from the provisioning pane.



Note This task does not apply to the TXP_MR_10G card.

- Step 1** In node view (single-shelf mode) or shelf view (multishelf view), double-click the TXP or MXP card where you want to delete PPM settings.
- Step 2** Click the **Provisioning > Pluggable Port Modules** tabs.
- Step 3** To delete a PPM and the associated ports:



Note You cannot delete a client port if the client is in the In Service and Normal (IS-NR) (ANSI) or Unlocked-enabled (ETSI) service state; is part of a protection group; has a generic communications channel (GCC) or data communications channel (DCC) in use; is used as a timing source; has circuits; or has overhead circuits. You can delete a client port if the trunk port is in service and the client port is in the OOS-MA,DSBLD (ANSI) or Locked-enabled,disabled (ETSI) service state, with the exception of the last port. You can delete the last client port only if the trunk port is in a OOS-MA,DSBLD (ANSI) or Locked-enabled,disabled (ETSI) service state for all cards except the MXP_MR_2.5G, MXPP_MR_2.5G, MXP_MR_10DME_C, and MXP_MR_10DME_L cards. For more information about port states, refer to “DWDM Administrative and Service States” appendix in the *Cisco DWDM Reference Manual*.

- a. In the Pluggable Port Modules area, click the PPM that you want to delete. The highlight changes to dark blue.
 - b. Click **Delete**. The Delete PPM dialog box appears.
 - c. Click **Yes**. The PPM provisioning is removed from the Pluggable Port Modules area and the Pluggable Ports area.
- Step 4** Verify that the PPM provisioning is deleted:
- In the TXP/MXP card view, CTC shows an empty port after the PPM is deleted.
 - If the SFP or XFP is physically present when you delete the PPM provisioning, CTC transitions to the deleted state, the ports (if any) are deleted, and the PPM is represented as a gray graphic in CTC. The SFP or XFP can be provisioned again in CTC, or the equipment can be removed, in which case the removal causes the graphic to disappear.
- Step 5** If you need to remove the PPM hardware (the SFP or XFP), complete the “[DLP-G64 Remove an SFP or XFP](#)” task on page 3-54.
- Step 6** Return to your originating procedure (NTP).

NTP-G33 Create a Y-Cable Protection Group

Purpose	This procedure creates a Y-cable protection group between the client ports of two transponder or muxponder cards. For additional information about Y-cable protection, see the “Card Reference” chapter in the <i>Cisco ONS 15454 DWDM Reference Manual</i> .
Tools/Equipment	Installed TXP or MXP cards Cisco MetroPlanner Traffic Matrix
Prerequisite Procedures	NTP-G15 Install the Common Control Cards, page 1-72 NTP-G14 Install DWDM Equipment, page 1-64 DLP-G46 Log into CTC, page 2-25 NTP-G139 Verify Cisco MetroPlanner Reports and Files, page 3-3
Required/As Needed	As needed
Onsite/Remote	Onsite or remote
Security Level	Provisioning or higher

Note

For SONET or SDH payloads, Loss of Pointer Path (LOP-P) alarms can occur on a split signal if the ports are not in a Y-cable protection group.

-
- Step 1** View the Cisco MetroPlanner Traffic Matrix (see [Table 3-1 on page 3-3](#)) for your site. Verify the TXP or MXP cards that need Y-cable protection groups. (Cards requiring Y-cable protection are indicated with “Y-Cable” in the Traffic Matrix table Protection Type column. Refer to the *Cisco MetroPlanner DWDM Operations Guide* for more information.)
- Step 2** Verify that the TXP or MXP cards are installed according to the requirements specified in [Table 3-3 on page 3-76](#). [Table 5-4](#) lists the protection types available in the ONS 15454 for DWDM client cards.

Table 5-4 Protection Types

Type	Cards	Description and Installation Requirements
Y-cable	MXP_2.5_10G MXP_2.5_10E MXP_2.5_10E_C MXP_2.5_10E_L TXP_MR_10G TXP_MR_10E TXP_MR_10E_C TXP_MR_10E_L TXP_MR_2.5G MXP_MR_2.5G MXP_MR_10DME_C MXP_MR_10DME_L	Pairs a working transponder or muxponder card/port with a protect transponder or muxponder card/port. The protect port must be on a different card than the working port and it must be the same card type as the working port. The working and protect port numbers must be the same, that is, Port 1 can only protect Port 1, Port 2 can only protect Port 2, etc.
Splitter	TXPP_MR_2.5G MXPP_MR_2.5G	A splitter protection group is automatically created when a TXPP_MR_2.5G or MXPP_MR_2.5G card is installed. You can edit the splitter protection group name.

- Step 3** Verify that pluggable ports are provisioned for the same payload and payload rate on the TXP and MXP cards where you will create the Y-cable protection group:
- Display the TXP or MXP card in card view.
 - Click the **Provisioning > Pluggable Port Module** tabs.
 - Verify that a pluggable port is provisioned in the Pluggable Port Module area, and the payload type and rate is provisioned for it in the Pluggable Ports area. If they are not the same, for example, if the pluggable port and rate are not the same, you must either delete the provisioned rate and create a new rate to match using the [“DLP-G273 Preprovision an SFP or XFP Slot” task on page 3-53](#) or replace the pluggable port (SFP or XFP). using the [“DLP-G64 Remove an SFP or XFP” task on page 3-54](#).
- Step 4** In node view (single-shelf mode) or shelf view (multishelf view), click the **Provisioning > Protection** tabs.
- Step 5** In the Protection Groups area, click **Create**.
- Step 6** In the Create Protection Group dialog box, enter the following:
- Name—Type a name for the protection group. The name can have up to 32 alphanumeric (a-z, A-Z, 0-9) characters. Special characters are permitted. For TL1 compatibility, do not use question mark (?), backslash (\), or double quote (") characters.
 - Type—Choose **Y Cable** from the drop-down list.
 - Protect Port—From the drop-down list, choose the port that will be the standby or protection port to the active port. The list displays the available transponder or muxponder ports. If transponder or muxponder cards are not installed, no ports appear in the drop-down list.

After you choose the protect port, a list of available working ports appear in the Available Ports list, as shown in Figure 5-5. If no cards are available, no ports appear. If this occurs, you can not complete this task until you install the physical cards or preprovision the ONS 15454 slots using the “DLP-G353 Preprovision a Single Slot” procedure on page 3-42.

Figure 5-5 Creating a Y-Cable Protection Group

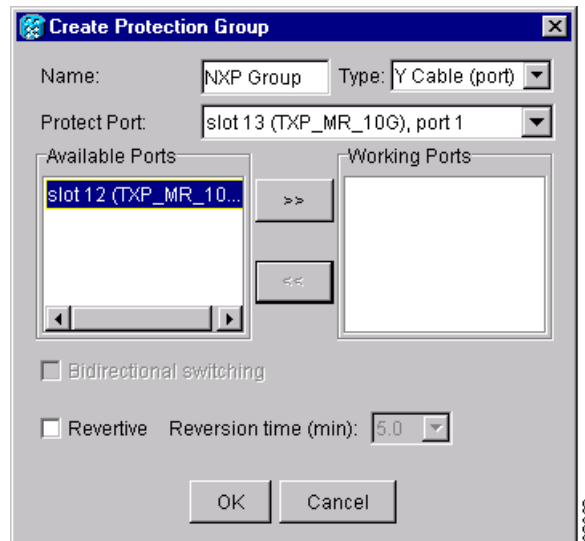

Step 7 From the Available Ports list, select the port that will be protected by the port you selected in Protect Ports. Click the top arrow button to move the port to the Working Ports list.

Step 8 Complete the remaining fields:

- **Revertive**—Check this check box if you want traffic to revert to the working port after failure conditions remain corrected for the amount of time entered in the Reversion Time field.
- **Reversion time**—If Revertive is checked, select a reversion time from the drop-down list. The range is 0.5 to 12.0 minutes. The default is 5.0 minutes. Reversion time is the amount of time that will elapse before the traffic reverts to the working card. The reversion timer starts after conditions causing the switch are cleared.



Note The Bidirectional switching option is available only for SONET and SDH 1+1 protection groups. It is not available for Y-cable protection groups.

Step 9 Click **OK**.

Step 10 Repeat this procedure for every Y-cable protection group indicated in the Cisco MetroPlanner Traffic Matrix.

Stop. You have completed this procedure.

NTP-G98 Provision the 2.5G Multirate Transponder Card Line Settings and PM Parameter Thresholds

Purpose	This procedure changes the line and threshold settings for TXP_MR_2.5G and TXPP_MR_2.5G transponder cards.
Tools/Equipment	None
Prerequisite Procedures	NTP-G32 Install the Transponder and Muxponder Cards, page 3-50 DLP-G63 Install an SFP or XFP, page 3-52 DLP-G277 Provision a Multirate PPM, page 5-6 (if necessary) DLP-G278 Provision the Optical Line Rate, page 5-9 (if necessary)
Required/As Needed	As needed
Onsite/Remote	Onsite or remote
Security Level	Provisioning or higher

-
- Step 1** Complete the “[DLP-G46 Log into CTC](#)” task on page 2-25 at the node where you want to change the transponder card settings. If you are already logged in, continue with [Step 2](#).
- Step 2** As needed, complete the “[NTP-G103 Back Up the Database](#)” procedure on page 13-2 to preserve the existing transmission settings.
- Step 3** Perform any of the following tasks as needed:
- [DLP-G229 Change the 2.5G Multirate Transponder Card Settings, page 5-18](#)
 - [DLP-G230 Change the 2.5G Multirate Transponder Line Settings, page 5-19](#)
 - [DLP-G231 Change the 2.5G Multirate Transponder Line Section Trace Settings, page 5-22](#)
 - [DLP-G232 Change the 2.5G Multirate Transponder SONET or SDH Line Threshold Settings, page 5-24](#)
 - [DLP-G320 Change the 2.5G Multirate Transponder Line RMON Thresholds for 1G Ethernet or 1G FC/FICON Payloads, page 5-27](#)
 - [DLP-G305 Provision the 2.5G Multirate Transponder Trunk Port Alarm and TCA Thresholds, page 5-28](#)
 - [DLP-G306 Provision the 2.5G Multirate Transponder Client Port Alarm and TCA Thresholds, page 5-30](#)
 - [DLP-G234 Change the 2.5G Multirate Transponder OTN Settings, page 5-34](#)
 - [DLP-G367 Change the 2.5G Multirate Transponder Trunk Wavelength Settings, page 5-23](#)
- Stop. You have completed this procedure.**
-

DLP-G229 Change the 2.5G Multirate Transponder Card Settings

Purpose	This task changes the card settings for TXP_MR_2.5G and TXPP_MR_2.5G transponder cards.
Tools/Equipment	None
Prerequisite Procedures	DLP-G46 Log into CTC, page 2-25
Required/As Needed	As needed
Onsite/Remote	Onsite or remote
Security Level	Provisioning or higher

-
- Step 1** In node view (single-shelf mode) or shelf view (multishelf view), double-click the TXP_MR_2.5G or TXPP_MR_2.5G card where you want to change the card settings.
- Step 2** Click the **Provisioning > Card** tabs.
- Step 3** Modify any of the settings described in [Table 5-5](#).



Note The Card subtab Framing Type and Tunable Wavelengths fields are display-only. Framing Type shows the card framing type, either SONET or SDH, depending on whether the card is installed in an ANSI or ETSI chassis. The Tunable Wavelengths shows the tunable wavelengths for the physical TXP_MR_2.5G and TXPP_MR_2.5G that is installed.

Table 5-5 *TXP_MR_2.5G and TXPP_MR_2.5G Transponder Card Settings*

Parameter	Description	Options
Termination Mode	Sets the mode of operation (option only supported for SONET/SDH payloads). Refer to the “Card Reference” chapter in the <i>Cisco ONS 15454 DWDM Reference Manual</i> for more details.	<ul style="list-style-type: none"> Transparent Section (ANSI) or Regeneration Section (ETSI) Line (ANSI) or Multiplex Section (ETSI)
Regeneration Peer Slot	<p>Sets the slot containing another TXP_MR_2.5G or TXPP_MR_2.5G card to create a regeneration peer group. A regeneration peer group facilitates the management of two TXP_MR_2.5G or TXPP_MR_2.5G cards that are needed to perform a complete signal regeneration.</p> <p>The regeneration peer group synchronizes provisioning of the two cards. Payload type and ITU-T G.709 optical transport network (OTN) changes made on one TXP_MR_2.5G or TXPP_MR_2.5G card are reflected on the peer TXP_MR_2.5G or TXPP_MR_2.5G card.</p> <p>Note Y-cable protection groups cannot be created on TXP_MR_2.5G or TXPP_MR_2.5G cards that are in a regeneration peer group.</p>	<ul style="list-style-type: none"> None 1 2 3 4 5 6 12 13 14 15 16 17
Regeneration Group Name	Sets the regeneration peer group name.	User defined.

Step 4 Click **Apply**.

Step 5 Return to your originating procedure (NTP).

DLP-G230 Change the 2.5G Multirate Transponder Line Settings

Purpose	This task changes the line settings for the client port of the TXP_MR_2.5G and TXPP_MR_2.5G transponder cards.
Tools/Equipment	None
Prerequisite Procedures	DLP-G46 Log into CTC, page 2-25
Required/As Needed	As needed
Onsite/Remote	Onsite or remote
Security Level	Provisioning or higher

- Step 1** In node view (single-shelf mode) or shelf view (multishelf view), double-click the TXP_MR_2.5G or TXPP_MR_2.5G card where you want to change the line settings.
- Step 2** Click the **Provisioning > Line > Pluggable Port Rate**, where *Pluggable Port Rate* is the pluggable port rate provisioned on the Pluggable Port Modules tab.
- Step 3** Modify any of the settings described in [Table 5-6](#).



Note The 2.5G multirate transponder trunk settings are provisioned in the “[DLP-G305 Provision the 2.5G Multirate Transponder Trunk Port Alarm and TCA Thresholds](#)” task on page 5-28.

Table 5-6 TXP_MR_2.5G and TXPP_MR_2.5G Transponder Card Line Settings

Parameter	Description	Options
Port	(Display only) Displays the port number.	<ul style="list-style-type: none"> 1 2 (Trunk) 3 (Trunk) (TXPP_MR_2.5G card only)
Port Name	The user can assign a logical name for each of the ports shown by filling in this field.	User-defined. Name can be up to 32 alphanumeric/special characters. Blank by default. See the “ DLP-G104 Assign a Name to a Port ” task on page 7-3.
Admin State	Sets the port service state unless network conditions prevent the change. For more information about administrative states, refer to the “Administrative and Service States” appendix in the <i>Cisco ONS 15454 DWDM Reference Manual</i> .	<ul style="list-style-type: none"> IS (ANSI) or Unlocked (ETSI) IS,AINS (ANSI) or Unlocked,automaticInService (ETSI) OOS,DSBLD (ANSI) or Locked,disabled (ETSI) OOS,MT (ANSI) or Locked,maintenance (ETSI)
Service State	(Display only) Identifies the autonomously generated state that gives the overall condition of the port. Service states appear in the format: Primary State-Primary State Qualifier, Secondary State. For more information about service states, refer to the “Administrative and Service States” appendix in the <i>Cisco ONS 15454 DWDM Reference Manual</i> .	<ul style="list-style-type: none"> IS-NR (ANSI) or Unlocked-enabled (ETSI) OOS-AU,AINS (ANSI) or Unlocked-disabled, automaticInService (ETSI) OOS-MA,DSBLD (ANSI) or Locked-enabled,disabled (ETSI) OOS-MA,MT (ANSI) or Locked-enabled,maintenance (ETSI)
SF BER	(OC-N and STM-N payloads only) Sets the signal fail bit error rate.	<ul style="list-style-type: none"> 1E-3 1E-4 1E-5
SD BER	(OC-N and STM-N payloads only) Sets the signal degrade bit error rate.	<ul style="list-style-type: none"> 1E-5 1E-6 1E-7 1E-8 1E-9

Table 5-6 *TXP_MR_2.5G and TXPP_MR_2.5G Transponder Card Line Settings (continued)*

Parameter	Description	Options
ALS Mode	Sets the automatic laser shutdown (ALS) function.	<ul style="list-style-type: none"> Disabled (default) Auto Restart Manual Restart Manual Restart for Test
Reach	Displays the optical reach distance of the client port.	Options: ANSI/ETSI <ul style="list-style-type: none"> Autoprovision/Autoprovision (default) SR SR 1/I-1—Short reach up to 2-km distance IR 1/S1—Intermediate reach, up to 15-km distance IR 2/S2—Intermediate reach up to 40-km distance LR 1/L1—long reach, up to 40-km distance LR 2/L2—long reach, up to 80-km distance LR 3/L3—long reach, up to 80-km distance
Wavelength	Displays the wavelength of the client port.	<ul style="list-style-type: none"> First Tunable Wavelength Further wavelengths: 1310 nm through 1560.61 nm, 100-GHz ITU spacing; coarse wavelength division multiplexing (CWDM) spacing Note: supported wavelengths are marked by asterisks (**).
AINS Soak	(OC-N and STM-N payloads only) Sets the automatic in-service soak period.	<ul style="list-style-type: none"> Duration of valid input signal, in hh.mm format, after which the card becomes in service (IS) automatically 0 to 48 hours, 15-minute increments
Type	(OC-N and STM-N payloads only) The optical transport type.	<ul style="list-style-type: none"> SONET SDH

Step 4 Click **Apply**.

Step 5 Return to your originating procedure (NTP).

DLP-G231 Change the 2.5G Multirate Transponder Line Section Trace Settings

Purpose	This task changes the section trace settings for TXP_MR_2.5G and TXPP_MR_2.5G transponder cards.
Tools/Equipment	None
Prerequisite Procedures	DLP-G46 Log into CTC, page 2-25
Required/As Needed	As needed
Onsite/Remote	Onsite or remote
Security Level	Provisioning or higher



Note This task only applies to SONET services.

- Step 1** In node view (single-shelf mode) or shelf view (multishelf view), double-click the TXP_MR_2.5G or TXPP_MR_2.5G card where you want to change the section trace settings.
- Step 2** Click the **Provisioning > Line > Section Trace** tabs.
- Step 3** Modify any of the settings described in [Table 5-7](#).

Table 5-7 TXP_MR_2.5G and TXPP_MR_2.5G Transponder Card Section Trace Settings

Parameter	Description	Options
Port	(Display only) Port number.	<ul style="list-style-type: none"> 1 2 (Trunk) 3 (Trunk) (TXPP_MR_2.5G only)
Received Trace Mode	Sets the trace mode.	<ul style="list-style-type: none"> Off/None Manual
Disable AIS/RDI on TIM-S	If an TIM on Section overhead alarm arises because of a J0 overhead string mismatch, no alarm indication signal is sent to downstream nodes if this box is checked.	<ul style="list-style-type: none"> Checked (AIS/RDI on TIM-S is disabled) Unchecked (AIS/RDI on TIM-S is not disabled)
Transmit Section Trace String Size	Sets the trace string size.	<ul style="list-style-type: none"> 1 byte 16 byte
Transmit	Displays the current transmit string; sets a new transmit string. You can click the button on the right to change the display. Its title changes, based on the current display mode. Click Hex to change the display to hexadecimal (button changes to ASCII); click ASCII to change the display to ASCII (button changes to Hex).	String of trace string size

Table 5-7 *TXP_MR_2.5G and TXPP_MR_2.5G Transponder Card Section Trace Settings*

Parameter	Description	Options
Expected	Displays the current expected string; sets a new expected string. You can click the button on the right to change the display. Its title changes, based on the current display mode. Click Hex to change the display to hexadecimal (button changes to ASCII); click ASCII to change the display to ASCII (button changes to Hex).	String of trace string size
Received	(Display only) Displays the current received string. You can click Refresh to manually refresh this display, or check the Auto-refresh every 5 sec check box to keep this display updated automatically.	String of trace string size
Auto-refresh	If checked, automatically refreshes the display every 5 seconds.	Checked/unchecked (default)

- Step 4** Click **Apply**.
- Step 5** Return to your originating procedure (NTP).

DLP-G367 Change the 2.5G Multirate Transponder Trunk Wavelength Settings

Purpose	This task changes the trunk wavelength settings for the TXP_MR_2.5G and TXPP_MR_2.5G.
Tools/Equipment	None
Prerequisite Procedures	DLP-G46 Log into CTC, page 2-25
Required/As Needed	As needed
Onsite/Remote	Onsite or remote
Security Level	Provisioning or higher

- Step 1** In node view (single-shelf mode) or shelf view (multishelf view), double-click the TXP_MR_2.5G or TXPP_MR_2.5G card where you want to change the trunk wavelength settings.
- Step 2** Click the **Provisioning > Line > Wavelength Trunk Settings** tabs.
- Step 3** Modify any of the settings for the Wavelength Trunk Settings tab as described in [Table 5-8](#).

Table 5-8 TXP_MR_2.5G and TXPP_MR_2.5G Card Wavelength Trunk Settings

Parameter	Description	Options
Port	(Display only) Displays the port number.	<ul style="list-style-type: none"> • 2 (Trunk) • 3 (Trunk) (TXPP_MR_2.5G only)
Band	Indicates the wavelength band that can be provisioned. For TXP_MR_2.5G and TXPP_MR_2.5G cards, the field is display-only.	C—Only the C band is available
Even/Odd	Sets the wavelengths available for provisioning. This field does not apply to TXP_MR_2.5G or TXPP_MR_2.5G cards	—
Wavelength	The wavelength provisioned for the trunk.	<ul style="list-style-type: none"> • First Tunable Wavelength • Further wavelengths in 100-GHz ITU-T, C-band spacing. If the card is installed, the wavelengths it carries are identified with two asterisks. Other wavelengths have a dark grey background. If the card is not installed, all wavelengths appear with a dark grey background.

Step 4 Click **Apply**.

Step 5 Return to your originating procedure (NTP).

DLP-G232 Change the 2.5G Multirate Transponder SONET or SDH Line Threshold Settings

Purpose	This task changes the line threshold settings for TXP_MR_2.5G and TXPP_MR_2.5G transponder cards carrying OC-3/STM-1, OC-12/STM-4, and OC-48/STM-16 payloads.
Tools/Equipment	None
Prerequisite Procedures	DLP-G46 Log into CTC, page 2-25
Required/As Needed	As needed
Onsite/Remote	Onsite or remote
Security Level	Provisioning or higher

Step 1 In node view (single-shelf mode) or shelf view (multishelf view), double-click the TXP_MR_2.5G or TXPP_MR_2.5G card where you want to change the line threshold settings.

Step 2 Click the **Provisioning > Line Thresholds** tabs.

**Note**

You must modify Near End and Far End independently; 15 Min and 1 Day independently; and Line and Section independently. To do so, choose the appropriate radio button and click **Refresh**.

Step 3 Modify any of the settings in [Table 5-9](#).

**Note**

Some parameters and options in [Table 5-9](#) do not apply to all TXP_MR_2.5G or TXPP_MR_2.5G cards. If a parameter or option does not apply, it does not appear in CTC.

Table 5-9 *TXP_MR_2.5G and TXPP_MR_2.5G Transponder Card Line Thresholds Settings for OC-3/STM-1, OC-12/STM-4, and OC-48/STM-16 Payloads*

Parameter	Description	Options - ANSI	Options - ETSI
Port	(Display only) Port number	<ul style="list-style-type: none"> 1 2 (Trunk) 3 (Trunk) (TXPP_MR_2.5G only) 	<ul style="list-style-type: none"> 1 2 (Trunk) 3 (Trunk) (TXPP_MR_2.5G only)
EB	Path Errored Block indicates that one or more bits are in error within a block	Numeric. Threshold display options include: <ul style="list-style-type: none"> Direction—Near End or Far End Interval—15 Min (minutes) or 1 day Types—Line or Section (near end only) Choose an option in each category and click Refresh .	Numeric. Threshold display options include: <ul style="list-style-type: none"> Direction—Near End or Far End Interval—15 Min (minutes) or 1 day Types—Multiplex Section or Regeneration Section (near end only) Choose an option in each category and click Refresh .
CV	Coding violations	Numeric. Threshold display options include: <ul style="list-style-type: none"> Direction—Near End or Far End Interval—15 Min (minutes) or 1 day Types—Line or Section (near end only) Choose an option in each category and click Refresh .	Numeric. Threshold display options include: <ul style="list-style-type: none"> Direction—Near End or Far End Interval—15 Min (minutes) or 1 day Types—Multiplex Section or Regeneration Section (near end only) Choose an option in each category and click Refresh .
ES	Errored seconds	Numeric. Threshold display options include: <ul style="list-style-type: none"> Direction—Near End or Far End Interval—15 Min (minutes) or 1 day Types—Line or Section (near end only) Choose an option in each category and click Refresh .	Numeric. Threshold display options include: <ul style="list-style-type: none"> Direction—Near End or Far End Interval—15 Min (minutes) or 1 day Types—Multiplex Section or Regeneration Section (near end only) Choose an option in each category and click Refresh .

Table 5-9 *TXP_MR_2.5G and TXPP_MR_2.5G Transponder Card Line Thresholds Settings for OC-3/STM-1, OC-12/STM-4, and OC-48/STM-16 Payloads (continued)*

Parameter	Description	Options - ANSI	Options - ETSI
SES	Severely errored seconds	Numeric. Threshold display options include: <ul style="list-style-type: none"> Direction—Near End or Far End Interval—15 Min (minutes) or 1 day Types—Line or Section (near end only) Choose an option in each category and click Refresh .	Numeric. Threshold display options include: <ul style="list-style-type: none"> Direction—Near End or Far End Interval—15 Min (minutes) or 1 day Types—Multiplex Section or Regeneration Section (near end only) Choose an option in each category and click Refresh .
FC	(Line or Multiplex Section only) Failure count	Numeric. Threshold display options include: <ul style="list-style-type: none"> Direction—Near End or Far End Interval—15 Min (minutes) or 1 day Types—Line or Section (near end only) Choose an option in each category and click Refresh .	Numeric. Threshold display options include: <ul style="list-style-type: none"> Direction—Near End or Far End Interval—15 Min (minutes) or 1 day Types—Multiplex Section or Regeneration Section (near end only) Choose an option in each category and click Refresh .
UAS	(Line or Multiplex Section only) Unavailable seconds	Numeric. Threshold display options include: <ul style="list-style-type: none"> Direction—Near End or Far End Interval—15 Min (minutes) or 1 day Types—Line or Section (near end only) Choose an option in each category and click Refresh .	Numeric. Threshold display options include: <ul style="list-style-type: none"> Direction—Near End or Far End Interval—15 Min (minutes) or 1 day Types—Multiplex Section or Regeneration Section (near end only) Choose an option in each category and click Refresh .
SEFS	(Near End Section or Regeneration Section only) Severely errored framing seconds	Numeric. Threshold display options include: <ul style="list-style-type: none"> Direction—Near End or Far End Interval—15 Min (minutes) or 1 day Types—Line or Section (near end only) Choose an option in each category and click Refresh .	Numeric. Threshold display options include: <ul style="list-style-type: none"> Direction—Near End or Far End Interval—15 Min (minutes) or 1 day Types—Multiplex Section or Regeneration Section (near end only) Choose an option in each category and click Refresh .

Step 4 Click **Apply**.

Step 5 Return to your originating procedure (NTP).

DLP-G320 Change the 2.5G Multirate Transponder Line RMON Thresholds for 1G Ethernet or 1G FC/FICON Payloads

Purpose	This task changes the line RMON threshold settings for TXP_MR_2.5G and TXPP_MR_2.5G transponder cards carrying the 1G Ethernet or 1G FC/FICON payloads.
Tools/Equipment	None
Prerequisite Procedures	DLP-G46 Log into CTC, page 2-25
Required/As Needed	As needed
Onsite/Remote	Onsite or remote
Security Level	Provisioning or higher

-
- Step 1** Display the TXP_MR_2.5G or TXPP_MR_2.5G card where you want to change the line threshold settings in card view.
- Step 2** Click the **Provisioning > Line Thresholds > RMON Thresholds** tabs.
- Step 3** Click **Create**. The Create Threshold dialog box appears.
- Step 4** From the Port drop-down list, choose the applicable port.
- Step 5** From the Variable drop-down list, choose an Ethernet variable. See [Table 5-10](#) for a list of available Ethernet variables.

Table 5-10 TXP_MR_2.5G and TXPP_MR_2.5G Card 1G Ethernet and 1G FC/FICON Thresholds

Variable	Description
ifInErrors	Number of inbound packets that contained errors preventing them from being deliverable to a higher-layer protocol.
rxTotalPkts	Total number of received packets.
8b10bStatsEncodingDispErrors	Number of IETF 8b10b disparity violations on the Fibre Channel line side.
8b10bIdleOrderedSets	Number of received packets containing idle ordered sets.
8b10bNonIdleOrderedSets	Number of received packets containing non-idle ordered sets.
8b10bDataOrderedSets	Number of received packets containing data ordered sets.

- Step 6** From the Alarm Type drop-down list, indicate whether the event will be triggered by the rising threshold, the falling threshold, or both the rising and falling thresholds.
- Step 7** From the Sample Type drop-down list, choose either **Relative** or **Absolute**. Relative restricts the threshold to use the number of occurrences in the user-set sample period. Absolute sets the threshold to use the total number of occurrences, regardless of time period.
- Step 8** Type in an appropriate number of seconds for the Sample Period.
- Step 9** Type in the appropriate number of occurrences for the Rising Threshold.

For a rising type of alarm, the measured value must move from below the falling threshold to above the rising threshold. For example, if a network is running below a rising threshold of 1000 collisions every 15 seconds and a problem causes 1001 collisions in 15 seconds, the excess occurrences trigger an alarm.

- Step 10** Enter the appropriate number of occurrences in the Falling Threshold field. In most cases a falling threshold is set lower than the rising threshold.

A falling threshold is the counterpart to a rising threshold. When the number of occurrences is above the rising threshold and then drops below a falling threshold, it resets the rising threshold. For example, when the network problem that caused 1001 collisions in 15 seconds subsides and creates only 799 collisions in 15 seconds, occurrences fall below a falling threshold of 800 collisions. This resets the rising threshold so that if network collisions again spike over a 1000 per 15-second period, an event again triggers when the rising threshold is crossed. An event is triggered only the first time a rising threshold is exceeded (otherwise, a single network problem might cause a rising threshold to be exceeded multiple times and cause a flood of events).

- Step 11** Click **OK**.
- Step 12** Return to your originating procedure (NTP).

DLP-G305 Provision the 2.5G Multirate Transponder Trunk Port Alarm and TCA Thresholds

Purpose	This task changes the TXP_MR_2.5G and TXPP_MR_2.5G trunk port alarm and threshold crossing alert (TCA) thresholds.
Tools/Equipment	None
Prerequisite Procedures	DLP-G46 Log into CTC, page 2-25
Required/As Needed	As needed
Onsite/Remote	Onsite or remote
Security Level	Provisioning or higher



Note In this task, trunk port refers to Port 2 for TXP_MR_2.5G cards, and to Ports 2 and 3 for TXPP_MR_2.5G cards.

- Step 1** In node view (single-shelf mode) or shelf view (multishelf view), double-click the TXP_MR_2.5G or TXPP_MR_2.5G card where you want to change the trunk port alarm and TCA settings.
- Step 2** Click the **Pluggable Port Modules** tab. Under Pluggable Ports, record the Rate that is provisioned.
- Step 3** Look up the rate in [Table 5-11](#) and determine whether it is 2R or 3R.

Table 5-11 2R and 3R Mode and ITU-T G.709 Compliance by Client Interface

Client Interface	Input Bit Rate	3R vs. 2R	ITU-T G.709
OC-48/STM-16	2.488 Gbps	3R	On or Off
DV-6000	2.38 Gbps	2R	—
2 Gigabit Fibre Channel (2G-FC)/fiber connectivity (FICON)	2.125 Gbps	3R ¹	On or Off
High-Definition Television (HDTV)	1.48 Gbps	2R	—
Gigabit Ethernet (GE)	1.25 Gbps	3R	On or Off

Table 5-11 2R and 3R Mode and ITU-T G.709 Compliance by Client Interface (continued)

Client Interface	Input Bit Rate	3R vs. 2R	ITU-T G.709
1 Gigabit Fibre Channel (1G-FC)/FICON	1.06 Gbps	3R	On or Off
OC-12/STM-4	622 Mbps	3R	On or Off
OC-3/STM-1	155 Mbps	3R	On or Off
Enterprise System Connection (ESCON)	200 Mbps	2R	—
SDI/D1 video	270 Mbps	2R	—
ISC-1 Compact	1.06 Gbps	3R	Off
ISC-3	1.06 or 2.125 Gbps	2R	—
ETR_CLO	16 Mbps	2R	—

1. No monitoring

Step 4 Click the **Provisioning > Optics Thresholds** tabs.

Step 5 Click the **15 Min** performance monitoring (PM) interval radio button and click **Refresh**.

Step 6 Referring to [Table 5-12 on page 5-29](#), provision the trunk port TCA thresholds for RX Power High and RX Power Low depending on whether the rate is 2R or 3R.



Note Do not modify the Laser Bias parameters.

Table 5-12 TXP_MR_2.5G and TXPP_MR_2.5G Trunk Port TCA Thresholds

Signal	TCA RX Power Low	TCA RX Power High
3R	-23 dBm	-9 dBm
2R	-24 dBm	-9 dBm

Step 7 Click **Apply**.

Step 8 Under Types, click the **Alarm** radio button and click **Refresh**.

Step 9 Provision the trunk port Alarm thresholds for RX Power High to -7 dBm, and for RX Power Low to -26 dBm.

Step 10 Click **Apply**.

Step 11 Under Types, click **TCA**, then click the **1 Day** interval. Click **Refresh**, then repeat Steps 6 through 10 for the 1-day interval. If you have completed both intervals, continue with [Step 12](#).

Step 12 Return to your originating procedure (NTP).

DLP-G306 Provision the 2.5G Multirate Transponder Client Port Alarm and TCA Thresholds

Purpose	This task provisions the client port alarm and TCA thresholds for the TXP_MR_2.5G and TXPP_MR_2.5G cards.
Tools/Equipment	None
Prerequisite Procedures	DLP-G278 Provision the Optical Line Rate, page 5-9 DLP-G46 Log into CTC, page 2-25
Required/As Needed	Required
Onsite/Remote	Onsite or remote
Security Level	Provisioning or higher

- Step 1** In node view (single-shelf mode) or shelf view (multishelf view), double-click the TXP_MR_2.5G or TXPP_MR_2.5G card where you want to change the client port alarm and TCA settings.
- Step 2** Click the **Provisioning > Optics Thresholds** tabs. The TCA thresholds are shown by default.
- Step 3** Referring to [Table 5-13](#), provision the Port 1 (client) TCA thresholds for RX Power High, RX Power Low, TX Power High, and TX Power Low based on the client interface at the other end. For additional information about client SFP and XFP interfaces, also known as PPMs, refer to the “Hardware Specifications” appendix in the *Cisco ONS 15454 DWDM Reference Manual*.



Note Do not modify the Laser Bias parameters.



Note You must modify 15 Min and 1 Day independently. To do so, choose the appropriate radio button and click **Refresh**.

Table 5-13 TXP_MR_2.5G and TXPP_MR_2.5G Card Client Interface TCA Thresholds

Port Type (by CTC)	Pluggable Port Module (SFP)	TCA RX Power Low	TCA RX Power High	TCA TX Power Low	TCA TX Power High
OC-3	15454-SFP3-1-IR	-23	-8	-21	-2
STM-1	15454E-SFP-L.1.1	-24	-10	-21	-2
OC-12	15454-SFP12-4-IR	-28	-7	-21	-2
STM-4	15454E-SFP-L.4.1	-28	-8	-21	-2
OC-48	ONS-SE-2G-S1	-18	-3	-16	3
	15454-SFP-OC48-IR	-18	0	-11	6
STM-16	ONS-SE-2G-S1	-18	-3	-16	3
	15454E-SFP-L.16.1	-18	0	-11	6

Table 5-13 TXP_MR_2.5G and TXPP_MR_2.5G Card Client Interface TCA Thresholds (continued)

Port Type (by CTC)	Pluggable Port Module (SFP)	TCA RX Power Low	TCA RX Power High	TCA TX Power Low	TCA TX Power High
ONE_GE	15454-SFP-GEFC-SX 15454E-SFP-GEFC-S ONS-SE-G2F-SX	-17	0	-16	3
	15454-SFP-GE+-LX 15454E-SFP-GE+-LX ONS-SE-G2F-LX	-20	-3	-16	3
ESCON	15454-SFP-200 15454E-SFP-200 ONS-SE-200-MM	-21	-14	-35	-8
DV6000	15454-SFP-OC48-IR	-28	-7	-21	-2
	15454E-SFP-L.16.1	-18	0	-11	6
SDI_D1_VIDEO	15454-SFP12-4-IR	-28	-7	-21	-2
	15454E-SFP-L.4.1	-28	-8	-21	-2
HDTV	15454-SFP-GE+-LX 15454E-SFP-GE+-LX ONS-SE-G2F-LX	-20	-3	-16	3
PASS-THRU	2R MODE (not specified)	—	—	—	—
FC1G	15454-SFP-GEFC-SX 15454E-SFP-GEFC-S ONS-SE-G2F-SX	-17	0	-16	3
	15454-SFP-GE+-LX 15454E-SFP-GE+-LX ONS-SE-G2F-LX	-20	-3	-16	3
FC2G	15454-SFP-GEFC-SX 15454E-SFP-GEFC-S ONS-SE-G2F-SX	-15	0	-16	3
	15454-SFP-GE+-LX 15454E-SFP-GE+-LX ONS-SE-G2F-LX	-20	-3	-16	3
FICON1G	15454-SFP-GEFC-SX 15454E-SFP-GEFC-S ONS-SE-G2F-SX	-17	0	-16	3
	15454-SFP-GE+-LX 15454E-SFP-GE+-LX ONS-SE-G2F-LX	-20	-3	-16	3
FICON2G	15454-SFP-GEFC-SX 15454E-SFP-GEFC-S ONS-SE-G2F-SX	-17	0	-16	3
	15454-SFP-GE+-LX 15454E-SFP-GE+-LX ONS-SE-G2F-LX	-20	-3	-16	3

Table 5-13 *TXP_MR_2.5G and TXPP_MR_2.5G Card Client Interface TCA Thresholds (continued)*

Port Type (by CTC)	Pluggable Port Module (SFP)	TCA RX Power Low	TCA RX Power High	TCA TX Power Low	TCA TX Power High
ETR_CLO	15454-SFP-200 15454E-SFP-200 ONS-SE-200-MM	-17	0	-16	3
ISC compat	15454-SFP-GE+-LX 15454E-SFP-GE+-LX ONS-SE-G2F-LX	-20	-3	-16	3
ISC peer	15454-SFP-GE+-LX 15454E-SFP-GE+-LX ONS-SE-G2F-LX	-20	-3	-16	3

Step 4 Click **Apply**.

Step 5 Under Types, click the **Alarm** radio button and click **Refresh**.

Step 6 Referring to [Table 5-14](#), provision the Alarm thresholds for RX Power High, RX Power Low, TX Power High, and TX Power Low based on the client interface that is provisioned.



Note You must modify 15 Min and 1 Day independently. To do so, choose the appropriate radio button and click **Refresh**.

Table 5-14 *TXP_MR_2.5G and TXPP_MR_2.5G Card Client Interface Alarm Thresholds*

Port Type (by CTC)	Pluggable Port Module (SFP)	Alarm RX Power Low	Alarm RX Power High	Alarm TX Power Low	Alarm TX Power High
OC-3	15454-SFP3-1-IR	-26	-5	-18	-5
STM-1	15454E-SFP-L.1.1	-27	-7	-18	-5
OC-12	15454-SFP12-4-IR	-31	-4	-18	-5
STM-4	15454E-SFP-L.4.1	-31	-5	-18	-5
OC-48	ONS-SE-2G-S1	-21	0	-13	0
	15454-SFP-OC48-IR	-21	3	-8	3
STM-16	ONS-SE-2G-S1	-21	0	-13	0
	15454E-SFP-L.16.1	-21	3	-8	3
ONE_GE	15454-SFP-GEFC-SX 15454E-SFP-GEFC-S ONS-SE-G2F-SX	-20	3	-13	-1
	15454-SFP-GE+-LX 15454E-SFP-GE+-LX ONS-SE-G2F-LX	-23	0	-13	0
ESCON	15454-SFP-200 15454E-SFP-200 ONS-SE-200-MM	-24	-11	-32	-11

Table 5-14 *TXP_MR_2.5G and TXPP_MR_2.5G Card Client Interface Alarm Thresholds (continued)*

Port Type (by CTC)	Pluggable Port Module (SFP)	Alarm RX Power Low	Alarm RX Power High	Alarm TX Power Low	Alarm TX Power High
DV6000	15454-SFP-OC48-IR	-31	-4	-18	-5
	15454E-SFP-L.16.1	-21	3	-8	3
SDI_D1_VIDEO	15454-SFP12-4-IR	-31	-4	-18	-5
	15454E-SFP-L.4.1	-31	-5	-18	-5
HDTV	15454-SFP-GE+-LX 15454E-SFP-GE+-LX ONS-SE-G2F-LX	-23	0	-13	0
PASS-THRU	2R MODE (not specified)	—	—	—	—
FC1G	15454-SFP-GEFC-SX 15454E-SFP-GEFC-S ONS-SE-G2F-SX	-20	3	-13	-1
	15454-SFP-GE+-LX 15454E-SFP-GE+-LX ONS-SE-G2F-LX	-23	0	-13	0
FC2G	15454-SFP-GEFC-SX 15454E-SFP-GEFC-S ONS-SE-G2F-SX	-18	3	-13	-1
	15454-SFP-GE+-LX 15454E-SFP-GE+-LX ONS-SE-G2F-LX	-23	0	-13	0
FICON1G	15454-SFP-GEFC-SX 15454E-SFP-GEFC-S ONS-SE-G2F-SX	-20	3	-13	-1
	15454-SFP-GE+-LX 15454E-SFP-GE+-LX ONS-SE-G2F-LX	-23	0	-13	0
FICON2G	15454-SFP-GEFC-SX 15454E-SFP-GEFC-S ONS-SE-G2F-SX	-20	3	-13	-1
	15454-SFP-GE+-LX 15454E-SFP-GE+-LX ONS-SE-G2F-LX	-23	0	-13	0
ETR_CLO	15454-SFP-200 15454E-SFP-200 ONS-SE-200-MM	-20	3	-13	-1
ISC compat	15454-SFP-GE+-LX 15454E-SFP-GE+-LX ONS-SE-G2F-LX	-23	0	-13	0
ISC peer	15454-SFP-GE+-LX 15454E-SFP-GE+-LX ONS-SE-G2F-LX	-23	0	-13	0

- Step 7** Click **Apply**.
- Step 8** Return to your originating procedure (NTP).

DLP-G234 Change the 2.5G Multirate Transponder OTN Settings

Purpose	This task changes the OTN settings for TXP_MR_2.5G and TXPP_MR_2.5G transponder cards.
Tools/Equipment	None
Prerequisite Procedures	DLP-G46 Log into CTC, page 2-25
Required/As Needed	As needed
Onsite/Remote	Onsite or remote
Security Level	Provisioning or higher

- Step 1** In node view (single-shelf mode) or shelf view (multishelf view), double-click the TXP_MR_2.5G or TXPP_MR_2.5G card where you want to change the OTN settings.
- Step 2** Click the **Provisioning > OTN** tabs, then choose one of the following subtabs: **OTN Lines**, **G.709 Thresholds**, **FEC Thresholds**, or **Trail Trace Identifier**.
- Step 3** Modify any of the settings described in Tables [5-15](#) through [5-18](#).



Note You must modify Near End and Far End; 15 Min and 1 Day; and SM and PM independently. To do so, choose the appropriate radio button and click **Refresh**.

[Table 5-15](#) describes the values on the Provisioning > OTN > OTN Lines tab.

Table 5-15 TXP_MR_2.5G and TXPP_MR_2.5G Transponder Card OTN Line Settings

Parameter	Description	Options
Port	(Display only) Displays the port number.	<ul style="list-style-type: none"> 2 (Trunk) 3 (Trunk) (TXPP_MR_2.5G)
G.709 OTN	Sets the OTN lines according to ITU-T G.709.	<ul style="list-style-type: none"> Enable Disable
FEC	Sets the OTN lines to forward error correction (FEC).	<ul style="list-style-type: none"> Enable Disable
SF BER	(Display only) The signal fail bit error rate.	<ul style="list-style-type: none"> 1E-5
SD BER	Sets the signal degrade bit error rate.	<ul style="list-style-type: none"> 1E-5 1E-6 1E-7 1E-8 1E-9

Table 5-16 describes the values on the Provisioning > OTN > G.709 Thresholds tab.

Table 5-16 TXP_MR_2.5G and TXPP_MR_2.5G Transponder Card ITU-T G.709 Threshold Settings

Parameter	Description	Options
Port ¹	(Display only) Port number.	<ul style="list-style-type: none"> 2 (Trunk) 3 (Trunk) (TXPP_MR_2.5G)
ES	Errored seconds	Numeric. Can be set for Near End or Far End, for 15-minute or one-day intervals, or for SM (OTUk) or PM (ODUk). Select a bullet and click Refresh .
SES	Severely errored seconds	Numeric. Can be set for Near End or Far End, for 15-minute or one-day intervals, or for SM (OTUk) or PM (ODUk). Select a bullet and click Refresh .
UAS	Unavailable seconds	Numeric. Can be set for Near End or Far End, for 15-minute or one-day intervals, or for SM (OTUk) or PM (ODUk). Select a bullet and click Refresh .
BBE	Background block errors	Numeric. Can be set for Near End or Far End, for 15-minute or one-day intervals, or for SM (OTUk) or PM (ODUk). Select a bullet and click Refresh .
FC	Failure counter	Numeric. Can be set for Near End or Far End, for 15-minute or one-day intervals, or for SM (OTUk) or PM (ODUk). Select a bullet and click Refresh .

1. Latency for a 1G-FC payload without ITU-T G.709 is 4 microseconds, and with ITU-T G.709 is 40 microseconds. Latency for a 2G-FC payload without ITU-T G.709 is 2 microseconds, and with ITU-T G.709 is 20 microseconds. Consider these values when planning a FC network that is sensitive to latency.

Table 5-17 describes the values on the Provisioning > OTN > FEC Threshold tab.

Table 5-17 TXP_MR_2.5G and TXPP_MR_2.5G Transponder Card FEC Threshold Settings

Parameter	Description	Options
Port	(Display only) Port number.	<ul style="list-style-type: none"> 2 (Trunk) 3 (Trunk) (TXPP_MR_2.5G)
Bit Errors Corrected	Sets the value for bit errors corrected.	Numeric. Can be set for 15-minute or one-day intervals.
Uncorrectable Words	Sets the value for uncorrectable words.	Numeric. Can be set for 15-minute or one-day intervals.

Table 5-18 describes the values on the Provisioning > OTN > Trail Trace Identifier tab.

Table 5-18 *TXP_MR_2.5G and TXPP_MR_2.5G Transponder Card Trail Trace Identifier Settings*

Parameter	Description	Options
Port	(Display only) Port number.	<ul style="list-style-type: none"> • 2 (Trunk) • 3 (Trunk) (TXPP_MR_2.5G)
Level	Sets the level.	<ul style="list-style-type: none"> • Section • Path
Received Trace Mode	Sets the trace mode.	<ul style="list-style-type: none"> • Off/None • Manual
Disable AIS/RDI on TIM-S	If an TIM on Section overhead alarm arises because of a J0 overhead string mismatch, no alarm indication signal is sent to downstream nodes if this box is checked.	<ul style="list-style-type: none"> • Checked (AIS/RDI on TIM-S is disabled) • Unchecked (AIS/RDI on TIM-S is not disabled)
Transmit	Displays the current transmit string; sets a new transmit string. You can click the button on the right to change the display. Its title changes, based on the current display mode. Click Hex to change the display to hexadecimal (button changes to ASCII); click ASCII to change the display to ASCII (button changes to Hex).	String of trace string size
Expected	Displays the current expected string; sets a new expected string. You can click the button on the right to change the display. Its title changes, based on the current display mode. Click Hex to change the display to hexadecimal (button changes to ASCII); click ASCII to change the display to ASCII (button changes to Hex).	String of trace string size
Received	(Display only) Displays the current received string. You can click Refresh to manually refresh this display, or check the Auto-refresh every 5 sec check box to keep this panel updated.	String of trace string size
Auto-refresh	If checked, automatically refreshes the display every 5 minutes.	Checked/unchecked (default)

Step 4 Click **Apply**.

Step 5 Return to your originating procedure (NTP).

NTP-G96 Provision the 10G Multirate Transponder Card Line Settings, PM Parameters, and Thresholds

Purpose	This procedure changes the line and threshold settings for 10G multirate transponder cards including the TXP_MR_10G, TXP_MR_10E, TXP_MR_10E_C, and TXP_MR_10E_L cards.
Tools/Equipment	None
Prerequisite Procedures	NTP-G32 Install the Transponder and Muxponder Cards, page 3-50 DLP-G63 Install an SFP or XFP, page 3-52 DLP-G277 Provision a Multirate PPM, page 5-6 (if necessary) DLP-G278 Provision the Optical Line Rate, page 5-9 (if necessary)
Required/As Needed	As needed
Onsite/Remote	Onsite or remote
Security Level	Provisioning or higher



Note The TXP_MR_10G card does not support PPMs.

- Step 1** Complete the “[DLP-G46 Log into CTC](#)” task on page 2-25 at the node where you want to change the transponder card settings. If you are already logged in, continue with [Step 2](#).
- Step 2** As needed, complete the “[NTP-G103 Back Up the Database](#)” procedure on page 13-2 to preserve the existing transmission settings.
- Step 3** If you are provisioning a TXP_MR_10G card, complete the “[DLP-G365 Provision the TXP_MR_10G Data Rate](#)” task on page 5-38. If not, continue with [Step 4](#).
- Step 4** Perform any of the following tasks as needed:
- [DLP-G216 Change the 10G Multirate Transponder Card Settings, page 5-38](#)
 - [DLP-G217 Change the 10G Multirate Transponder Line Settings, page 5-40](#)
 - [DLP-G218 Change the 10G Multirate Transponder Line Section Trace Settings, page 5-43](#)
 - [DLP-G219 Change the 10G Multirate Transponder Line Thresholds for SONET or SDH Payloads Including 10G Ethernet WAN Phy, page 5-45](#)
 - [DLP-G319 Change the 10G Multirate Transponder Line RMON Thresholds for 10G Ethernet LAN Phy Payloads, page 5-48](#)
 - [DLP-G301 Provision the 10G Multirate Transponder Trunk Port Alarm and TCA Thresholds, page 5-51](#)
 - [DLP-G302 Provision the 10G Multirate Transponder Client Port Alarm and TCA Thresholds, page 5-52](#)
 - [DLP-G221 Change the 10G Multirate Transponder OTN Settings, page 5-54](#)
 - [DLP-G368 Change the 10G Multirate Transponder Trunk Wavelength Settings, page 5-44](#)

Stop. You have completed this procedure.

DLP-G365 Provision the TXP_MR_10G Data Rate

Purpose	This task changes the TXP_MR_10G data rate.
Tools/Equipment	None
Prerequisite Procedures	DLP-G46 Log into CTC, page 2-25
Required/As Needed	As needed
Onsite/Remote	Onsite or remote
Security Level	Provisioning or higher

-
- Step 1** In node view (single-shelf mode) or shelf view (multishelf view), double-click the TXP_MR_10G card where you want to change the card data rate settings.
- Step 2** Click the **Provisioning > Data Rate Selection** tabs.
- Step 3** Click Create.
- Step 4** In the Create Port dialog box, choose one of the following data rates:
- SONET (ANSI) or SDH (ETSI) (including 10G Ethernet WAN Phy)
 - 10G Ethernet LAN Phy
- Step 5** Click **Ok**.
- Step 6** Return to your originating procedure.
-

DLP-G216 Change the 10G Multirate Transponder Card Settings

Purpose	This task changes the card settings for the TXP_MR_10G, TXP_MR_10E, TXP_MR_10E_C, and TXP_MR_10E_L cards.
Tools/Equipment	None
Prerequisite Procedures	DLP-G46 Log into CTC, page 2-25
Required/As Needed	As needed
Onsite/Remote	Onsite or remote
Security Level	Provisioning or higher

-
- Step 1** In node view (single-shelf mode) or shelf view (multishelf view), double-click the TXP_MR_10G, TXP_MR_10E, TXP_MR_10E_C, or TXP_MR_10E_L card where you want to change the card settings.
- Step 2** Click the **Provisioning > Card** tabs.
- Step 3** Modify any of the settings described in [Table 5-19](#).

Table 5-19 TXP_MR_10G, TXP_MR_10E, TXP_MR_10E_C, or TXP_MR_10E_L Card Settings

Parameter	Description	ONS 15454 Options	ONS 15454 SDH Options
Termination Mode	Sets the mode of operation. (This option is only available for SONET/SDH payloads). Refer to the “Card Reference” chapter in the <i>Cisco ONS 15454 DWDM Reference Manual</i> for more details.	<ul style="list-style-type: none"> Transparent Section (TXP_MR_10E only) Line 	<ul style="list-style-type: none"> Transparent Regeneration Section (TXP_MR_10E only) Multiplex Section
AIS/Squelch Configuration	(TXP_MR_10E, TXP_MR_10E_C, or TXP_MR_10E_L only) Sets the transparent termination mode configuration.	<ul style="list-style-type: none"> Squelch AIS 	<ul style="list-style-type: none"> Squelch AIS
Regeneration Peer Slot	<p>Sets the slot containing another TXP_MR_10G, TXP_MR_10E, TXP_MR_10E_C, or TXP_MR_10E_L card to create a regeneration peer group. A regeneration peer group facilitates the management of two TXP_MR_10G, TXP_MR_10E, TXP_MR_10E_C, or TXP_MR_10E_L cards that are needed to perform a complete signal regeneration.</p> <p>The regeneration peer group synchronizes provisioning of the two cards. Payload type and ITU-T G.709 optical transport network (OTN) changes made on one TXP_MR_10G, TXP_MR_10E, TXP_MR_10E_C, or TXP_MR_10E_L card are reflected on the peer TXP_MR_10G, TXP_MR_10E, TXP_MR_10E_C, or TXP_MR_10E_L card.</p> <p>Note Y-cable protection groups cannot be created on TXP cards that are in a regeneration peer group.</p>	<ul style="list-style-type: none"> None 1 2 3 4 5 6 12 13 14 15 16 17 	<ul style="list-style-type: none"> None 1 2 3 4 5 6 12 13 14 15 16 17
Regeneration Group Name	(Display only) The regeneration peer group name.	—	—
Tunable Wavelengths	(Display only) Shows the supported wavelengths of the trunk port after the card is installed. For the TXP_MR_10E_C, or TXP_MR_10E_L cards, the first and last supported wavelength, frequency spacing, and number of supported wavelengths are shown in the format: <i>first wavelength-last wavelength-frequency spacing-number of supported wavelengths</i> . For example, the TXP_MR_10E_C card would show: 1529.55nm-1561.83nm-50GHz-82. The TXP_MR_10G and TXP_MR_10E show the four wavelengths supported by the card that is installed.	—	—

Step 4 Click **Apply**.

Step 5 Return to your originating procedure (NTP).

DLP-G217 Change the 10G Multirate Transponder Line Settings

Purpose	This task changes the line settings for TXP_MR_10G, TXP_MR_10E, TXP_MR_10E_C, and TXP_MR_10E_L cards.
Tools/Equipment	None
Prerequisite Procedures	DLP-G46 Log into CTC, page 2-25
Required/As Needed	As needed
Onsite/Remote	Onsite or remote
Security Level	Provisioning or higher

- Step 1** In node view (single-shelf mode) or shelf view (multishelf view), double-click the TXP_MR_10G, TXP_MR_10E, TXP_MR_10E_C, or TXP_MR_10E_L card where you want to change the line settings.
- Step 2** Click the **Provisioning > Line > Service** where Service = SONET (including 10G Ethernet WAN phy) (ANSI), SDH (including 10G Ethernet WAN phy) (ETSI) or Ethernet (when the Pluggable Port Rate is set to 10GE LAN Phy) tabs.
- Step 3** Modify any of the settings described in [Table 5-20](#).



Note In [Table 5-20](#), some parameter tabs do not always apply to all 10G multirate transponder cards. If a tab does not apply, it will not appear in CTC.

Table 5-20 TXP_MR_10G, TXP_MR_10E, TXP_MR_10E_C, or TXP_MR_10E_L Line Settings

Parameter	Description	ONS 15454 Options	ONS 15454 SDH Options
Port	(Display only) Displays the port number.	<ul style="list-style-type: none"> 1 (OC192) (if TXP_MR_10G) 1 (Client) (if Ethernet LAN is provisioned) 1-1 (OC192) 2 (Trunk) 	<ul style="list-style-type: none"> 1 (STM-64) (if TXP_MR_10G) 1 (Client) (if Ethernet LAN is provisioned) 1-1 (STM-64) 2 (Trunk)
Port Name	Provides the ability to assign the specified port a name.	User-defined. Name can be up to 32 alphanumeric/special characters. Blank by default. See the “ DLP-G104 Assign a Name to a Port ” task on page 7-3.	User-defined. Name can be up to 32 alphanumeric/special characters. Blank by default. See the “ DLP-G104 Assign a Name to a Port ” task on page 7-3.
Admin State	Sets the port service state. For more information about administrative states, refer to the “Administrative and Service States” appendix in the <i>Cisco ONS 15454 DWDM Reference Manual</i> .	<ul style="list-style-type: none"> IS IS,AINS OOS,DSBLD OOS,MT 	<ul style="list-style-type: none"> Unlocked Unlocked,automaticInService Locked,disabled Locked,maintenance

Table 5-20 TXP_MR_10G, TXP_MR_10E, TXP_MR_10E_C, or TXP_MR_10E_L Line Settings (continued)

Parameter	Description	ONS 15454 Options	ONS 15454 SDH Options
Service State	(Display only) Identifies the autonomously generated state that gives the overall condition of the port. Service states appear in the format: Primary State-Primary State Qualifier, Secondary State. For more information about service states, refer to the “Administrative and Service States” appendix in the <i>Cisco ONS 15454 DWDM Reference Manual</i> .	<ul style="list-style-type: none"> IS-NR OOS-AU,AINS OOS-MA,DSBLD OOS-MA,MT 	<ul style="list-style-type: none"> Unlocked-enabled Unlocked-disabled, automaticInService Locked-enabled,disabled Locked-enabled,maintenance
SF BER	(SONET [ANSI] or SDH [ETSI] including 10G Ethernet WAN Phy only) Sets the signal fail bit error rate.	<ul style="list-style-type: none"> 1E-3 1E-4 1E-5 	<ul style="list-style-type: none"> 1E-3 1E-4 1E-5
SD BER	(SONET [ANSI] or SDH [ETSI] including 10G Ethernet WAN Phy only) Sets the signal degrade bit error rate.	<ul style="list-style-type: none"> 1E-5 1E-6 1E-7 1E-8 1E-9 	<ul style="list-style-type: none"> 1E-5 1E-6 1E-7 1E-8 1E-9
Type	(SONET [ANSI] or SDH [ETSI] including 10G Ethernet WAN Phy only) The optical transport type.	<ul style="list-style-type: none"> SONET SDH 	<ul style="list-style-type: none"> SONET SDH
ALS Mode	Sets the ALS function mode. The DWDM transmitter supports ALS according to ITU-T G.644 (06/99). ALS can be disabled, or it can be set for one of three mode options.	<ul style="list-style-type: none"> Disabled (default): ALS is off; the laser is not automatically shut down when traffic outages (LOS) occur. Auto Restart: ALS is on; the laser automatically shuts down when traffic outages (LOS) occur. It automatically restarts when the conditions that caused the outage are resolved. Manual Restart: ALS is on; the laser automatically shuts down when traffic outages (LOS) occur. However, the laser must be manually restarted when conditions that caused the outage are resolved. Manual Restart for Test: Manually restarts the laser for testing. 	<ul style="list-style-type: none"> Disabled (default): ALS is off; the laser is not automatically shut down when traffic outages (LOS) occur. Auto Restart: ALS is on; the laser automatically shuts down when traffic outages (LOS) occur. It automatically restarts when the conditions that caused the outage are resolved. Manual Restart: ALS is on; the laser automatically shuts down when traffic outages (LOS) occur. However, the laser must be manually restarted when conditions that caused the outage are resolved. Manual Restart for Test: Manually restarts the laser for testing.

Table 5-20 TXP_MR_10G, TXP_MR_10E, TXP_MR_10E_C, or TXP_MR_10E_L Line Settings (continued)

Parameter	Description	ONS 15454 Options	ONS 15454 SDH Options
AINS Soak	(SONET [ANSI] or SDH [ETSI] including 10G Ethernet WAN Phy only) Sets the automatic in-service soak period. Double-click the time and use the up and down arrows to change settings.	<ul style="list-style-type: none"> Duration of valid input signal, in hh.mm format, after which the card becomes in service (IS) automatically 0 to 48 hours, 15-minute increments 	<ul style="list-style-type: none"> Duration of valid input signal, in hh.mm format, after which the card becomes in service (IS) automatically 0 to 48 hours, 15-minute increments
ProvidesSync	(TXP_MR_10G, TXP_MR_10E, OC192 only) Sets the ProvidesSync card parameter. If checked, the card is provisioned as a network element (NE) timing reference.	Checked or unchecked	Checked or unchecked
SyncMsgIn	(TXP_MR_10G, TXP_MR_10E, OC192 only) Sets the EnableSync card parameter. Enables synchronization status messages (S1 byte), which allow the node to choose the best timing source.	Checked or unchecked	Checked or unchecked
Max Size	(TXP_MR_10E, TXP_MR_10G LAN Phy only) Sets the maximum Ethernet packet size.	<ul style="list-style-type: none"> 1548 bytes Jumbo (64 to 9,216 bytes) 	<ul style="list-style-type: none"> 1548 bytes Jumbo (64 to 9,216 bytes)
Incoming MAC Address	(TXP_MR_10E, TXP_MR_10G LAN Phy only) Sets the incoming MAC address.	Value of MAC address. Six bytes in hexadecimal format.	Value of MAC address. Six bytes in hexadecimal format.
Wavelength	Displays the wavelength of the client port.	<ul style="list-style-type: none"> First Tunable Wavelength Further wavelengths: 1310 nm through 1560.61 nm, 100-GHz ITU spacing; coarse wavelength division multiplexing (CWDM) spacing <p>Note: supported wavelengths are marked by asterisks (**)</p>	<ul style="list-style-type: none"> First Tunable Wavelength Further wavelengths: 1310 nm through 1560.61 nm, 100-GHz ITU spacing; coarse wavelength division multiplexing (CWDM) spacing <p>Note: supported wavelengths are marked by asterisks (**)</p>
Reach	Displays the optical reach distance of the client port.	The Reach options depend on the traffic type that has been selected.	The Reach options depend on the traffic type that has been selected.

Step 4 Click **Apply**.

Step 5 Return to your originating procedure (NTP).

DLP-G218 Change the 10G Multirate Transponder Line Section Trace Settings

Purpose	This task changes the line section trace settings for the TXP_MR_10G, TXP_MR_10E, TXP_MR_10E_C, and TXP_MR_10E_L transponder cards.
Tools/Equipment	None
Prerequisite Procedures	DLP-G46 Log into CTC, page 2-25
Required/As Needed	As needed
Onsite/Remote	Onsite or remote
Security Level	Provisioning or higher



Note The Section Trace tab is available for the 10G Multirate Transponder cards only if no PPMs are provisioned, or the OC192 PPM is provisioned. The tab is not available if a 10G Ethernet LAN Phy or 10G Fibre Channel PPM is provisioned.

- Step 1** In node view (single-shelf mode) or shelf view (multishelf view), double-click the TXP_MR_10G, TXP_MR_10E, TXP_MR_10E_C, or TXP_MR_10E_L card where you want to change the section trace settings.
- Step 2** Click the **Provisioning > Line > Section Trace** tabs.
- Step 3** Modify any of the settings described in [Table 5-21](#).

Table 5-21 TXP_MR_10G, TXP_MR_10E, TXP_MR_10E_C, or TXP_MR_10E_L Section Trace Settings

Parameter	Description	ONS 15454 Options	Options — ONS 15454 SDH
Port	Sets the port number.	<ul style="list-style-type: none"> 1-1 (OC192) 2—Trunk 	<ul style="list-style-type: none"> 1-1 (STM64) 2—Trunk
Received Trace Mode	Sets the trace mode.	<ul style="list-style-type: none"> Off/None Manual 	<ul style="list-style-type: none"> Off/None Manual
Transmit Section Trace String Size	Sets the trace string size.	<ul style="list-style-type: none"> 1 byte 16 byte 	<ul style="list-style-type: none"> 1 byte 16 byte
Transmit	Displays the current transmit string; sets a new transmit string. You can click the button on the right to change the display. Its title changes, based on the current display mode. Click Hex to change the display to hexadecimal (button changes to ASCII); click ASCII to change the display to ASCII (button changes to Hex).	String of trace string size	String of trace string size
Disable AIS/RDI on TIM-S	If an TIM on Section overhead alarm arises because of a J0 overhead string mismatch, no alarm indication signal is sent to downstream nodes if this box is checked.	<ul style="list-style-type: none"> Checked (AIS/RDI on TIM-S is disabled) Unchecked (AIS/RDI on TIM-S is not disabled) 	<ul style="list-style-type: none"> Checked (AIS/RDI on TIM-S is disabled) Unchecked (AIS/RDI on TIM-S is not disabled)

Table 5-21 TXP_MR_10G, TXP_MR_10E, TXP_MR_10E_C, or TXP_MR_10E_L Section Trace Settings (continued)

Parameter	Description	ONS 15454 Options	Options — ONS 15454 SDH
Expected	Displays the current expected string; sets a new expected string. You can click the button on the right to change the display. Its title changes, based on the current display mode. Click Hex to change the display to hexadecimal (button changes to ASCII); click ASCII to change the display to ASCII (button changes to Hex).	String of trace string size	String of trace string size
Received	(Display only) Displays the current received string. You can click Refresh to manually refresh this display, or check the Auto-refresh every 5 sec check box to keep this panel updated.	String of trace string size	String of trace string size
Auto-refresh	If checked, automatically refreshes the display every 5 seconds.	Checked/unchecked (default)	Checked/unchecked (default)

Step 4 Click **Apply**.

Step 5 Return to your originating procedure (NTP).

DLP-G368 Change the 10G Multirate Transponder Trunk Wavelength Settings

Purpose	This task changes the trunk wavelength settings for the TXP_MR_10G, TXP_MR_10E, TXP_MR_10E_C, and TXP_MR_10E_L cards.
Tools/Equipment	None
Prerequisite Procedures	DLP-G46 Log into CTC, page 2-25
Required/As Needed	As needed
Onsite/Remote	Onsite or remote
Security Level	Provisioning or higher



Note

Before modifying the wavelength settings, change the port state to OOS,DSBLD (for ANSI) or Locked,disabled (for ETSI) and delete the circuit and patchcord provisioning present on the port. Payload or communication channel provisioning can be retained.

Step 1 In node view (single-shelf mode) or shelf view (multishelf view), double-click the TXP_MR_10G, TXP_MR_10E, TXP_MR_10E_C, and TXP_MR_10E_L card where you want to change the trunk wavelength settings.

Step 2 Click the **Provisioning > Line > Wavelength Trunk Settings** tabs.

Step 3 Modify any of the settings for the Wavelength Trunk Settings tab as described in [Table 5-22](#).

Table 5-22 *TXP_MR_10G, TXP_MR_10E, TXP_MR_10E_C, and TXP_MR_10E_L Card Wavelength Trunk Settings*

Parameter	Description	Options
Port	(Display only) Displays the port number.	Port 2 (Trunk)
Band	Indicates the wavelength band that can be provisioned. If the physical TXP_MR_10G, TXP_MR_10E, TXP_MR_10E_C, and TXP_MR_10E_L is installed, this field is display-only.	<ul style="list-style-type: none"> C—The C-band wavelengths are available in the Wavelength field. L—The L-band wavelengths are available in the Wavelength field.
Even/Odd	Sets the wavelengths available for provisioning for TXP_MR_10E_C, and TXP_MR_10E_L cards. (This field does not apply to TXP_MR_10G or TXP_MR_10E cards.)	<ul style="list-style-type: none"> Even—Displays even C-band or L-band wavelengths in the Wavelength field. Odd—Displays odd C-band or L-band wavelengths in the Wavelength field.
Wavelength	The wavelength provisioned for the trunk.	<ul style="list-style-type: none"> First Tunable Wavelength Further wavelengths in 100-GHz ITU-T C-band or L-band spacing, depending on the card that is installed. For TXP_MR_10G and TXP_MR_10E cards, the wavelengths carried by the card are identified with two asterisks. If the card is not installed, all wavelengths appear with a dark grey background.

Step 4 Click **Apply**.

Step 5 Return to your originating procedure (NTP).

DLP-G219 Change the 10G Multirate Transponder Line Thresholds for SONET or SDH Payloads Including 10G Ethernet WAN Phy

Purpose	This task changes the line threshold settings for TXP_MR_10G, TXP_MR_10E, TXP_MR_10E_C, and TXP_MR_10E_L transponder cards carrying SONET or SDH payloads, including the physical 10G Ethernet WAN Phy payload.
Tools/Equipment	None
Prerequisite Procedures	DLP-G46 Log into CTC, page 2-25
Required/As Needed	As needed
Onsite/Remote	Onsite or remote
Security Level	Provisioning or higher

- Step 1** In node view (single-shelf mode) or shelf view (multishelf view), double-click the TXP_MR_10G, TXP_MR_10E, TXP_MR_10E_C, or TXP_MR_10E_L card where you want to change the line threshold settings.
- Step 2** Click the **Provisioning > Line Thresholds > SONET Thresholds (ANSI)** or **SDH Thresholds (ETSI)** tabs.
- Step 3** Modify any of the settings described in [Table 5-23](#).



Note Parameters shown in [Table 5-23](#) do not apply to all 10G multirate transponder cards. If the parameter or option does not apply, it is not shown in CTC.

Table 5-23 TXP_MR_10G, TXP_MR_10E, TXP_MR_10E_C, or TXP_MR_10E_L Card Line Threshold Settings

Parameter	Description	Options - ANSI	Options - ETSI
Port	(Display only) Port number	<ul style="list-style-type: none"> 1-1 (OC192) 2 (Trunk) 	<ul style="list-style-type: none"> 1-1 (STM64) 2 (Trunk)
EB	Path Errored Block indicates that one or more bits are in error within a block	Numeric. Threshold display options include: <ul style="list-style-type: none"> Direction—Near End or Far End Interval—15 Min (minutes) or 1 day Types—Line or Section (near end only) Choose an option in each category and click Refresh .	Numeric. Threshold display options include: <ul style="list-style-type: none"> Direction—Near End or Far End Interval—15 Min (minutes) or 1 day Types—Multiplex Section or Regeneration Section (near end only) Choose an option in each category and click Refresh .
CV	Coding violations	Numeric. Threshold display options include: <ul style="list-style-type: none"> Direction—Near End or Far End Interval—15 Min (minutes) or 1 day Types—Line or Section (near end only) Choose an option in each category and click Refresh .	Numeric. Threshold display options include: <ul style="list-style-type: none"> Direction—Near End or Far End Interval—15 Min (minutes) or 1 day Types—Multiplex Section or Regeneration Section (near end only) Choose an option in each category and click Refresh .
ES	Errored seconds	Numeric. Threshold display options include: <ul style="list-style-type: none"> Direction—Near End or Far End Interval—15 Min (minutes) or 1 day Types—Line or Section (near end only) Choose an option in each category and click Refresh .	Numeric. Threshold display options include: <ul style="list-style-type: none"> Direction—Near End or Far End Interval—15 Min (minutes) or 1 day Types—Multiplex Section or Regeneration Section (near end only) Choose an option in each category and click Refresh .

Table 5-23 TXP_MR_10G, TXP_MR_10E, TXP_MR_10E_C, or TXP_MR_10E_L Card Line Threshold Settings (continued)

Parameter	Description	Options - ANSI	Options - ETSI
SES	Severely errored seconds	Numeric. Threshold display options include: <ul style="list-style-type: none"> Direction—Near End or Far End Interval—15 Min (minutes) or 1 day Types—Line or Section (near end only) Choose an option in each category and click Refresh .	Numeric. Threshold display options include: <ul style="list-style-type: none"> Direction—Near End or Far End Interval—15 Min (minutes) or 1 day Types—Multiplex Section or Regeneration Section (near end only) Choose an option in each category and click Refresh .
SEFS	(Near End Section or Regeneration Section only) Severely errored framing seconds	Numeric. Threshold display options include: <ul style="list-style-type: none"> Direction—Near End or Far End Interval—15 Min (minutes) or 1 day Types—Line or Section (near end only) Choose an option in each category and click Refresh .	Numeric. Threshold display options include: <ul style="list-style-type: none"> Direction—Near End or Far End Interval—15 Min (minutes) or 1 day Types—Multiplex Section or Regeneration Section (near end only) Choose an option in each category and click Refresh .
BBE	Background block errors	Numeric. Threshold display options include: <ul style="list-style-type: none"> Direction—Near End or Far End Interval—15 Min (minutes) or 1 day Types—Line or Section (near end only) Choose an option in each category and click Refresh .	Numeric. Threshold display options include: <ul style="list-style-type: none"> Direction—Near End or Far End Interval—15 Min (minutes) or 1 day Types—Multiplex Section or Regeneration Section (near end only) Choose an option in each category and click Refresh .
FC	(Line or Multiplex Section only) Failure count	Numeric. Threshold display options include: <ul style="list-style-type: none"> Direction—Near End or Far End Interval—15 Min (minutes) or 1 day Types—Line or Section (near end only) Choose an option in each category and click Refresh .	Numeric. Threshold display options include: <ul style="list-style-type: none"> Direction—Near End or Far End Interval—15 Min (minutes) or 1 day Types—Multiplex Section or Regeneration Section (near end only) Choose an option in each category and click Refresh .
UAS	(Line or Multiplex Section only) Unavailable seconds	Numeric. Threshold display options include: <ul style="list-style-type: none"> Direction—Near End or Far End Interval—15 Min (minutes) or 1 day Types—Line or Section (near end only) Choose an option in each category and click Refresh .	Numeric. Threshold display options include: <ul style="list-style-type: none"> Direction—Near End or Far End Interval—15 Min (minutes) or 1 day Types—Multiplex Section or Regeneration Section (near end only) Choose an option in each category and click Refresh .

- Step 4** Click **Apply**.
- Step 5** Return to your originating procedure (NTP).

DLP-G319 Change the 10G Multirate Transponder Line RMON Thresholds for 10G Ethernet LAN Phy Payloads

Purpose	This task changes the line threshold settings for TXP_MR_10G, TXP_MR_10E, TXP_MR_10E_C, and TXP_MR_10E_L transponder cards carrying the physical 10G Ethernet LAN payload.
Tools/Equipment	None
Prerequisite Procedures	DLP-G46 Log into CTC, page 2-25
Required/As Needed	As needed
Onsite/Remote	Onsite or remote
Security Level	Provisioning or higher

- Step 1** Display the TXP_MR_10G, TXP_MR_10E, TXP_MR_10E_C, or TXP_MR_10E_L card where you want to change the line threshold settings in card view.
- Step 2** Click the **Provisioning > Line Thresholds > RMON Thresholds** tabs.
- Step 3** Click **Create**. The Create Threshold dialog box appears.
- Step 4** From the Port drop-down list, choose the applicable port.
- Step 5** From the Variable drop-down list, choose an Ethernet variable. See [Table 5-24](#) for a list of available Ethernet variables.

Table 5-24 TXP_MR_10G, TXP_MR_10E, TXP_MR_10E_C, or TXP_MR_10E_L Card GE LAN Phy Variables

Variable	Description
ifInOctets	Total number of octets received on the interface, including framing characters.
rxTotalPkts	Total number of received packets.
ifInMulticastPkts	Number of multicast frames received error free.
ifInBroadcastPkts	Number of packets, delivered by a sublayer to an higher sublayer, that were addressed to a broadcast address at this sublayer.
ifInErrors	Number of inbound packets that contained errors preventing them from being delivered to a higher-layer protocol.
ifInErrorBytePkts	Number of receive error bytes.
ifInFramingErrorPkts	Number of receive framing error counters.
ifInJunkInterPkts	Number of receive interpacket junk counters.
ifOutOctets	Total number of octets transmitted out of the interface, including framing characters.
txTotalPkts	Total number of transmit packets.

Table 5-24 *TXP_MR_10G, TXP_MR_10E, TXP_MR_10E_C, or TXP_MR_10E_L Card GE LAN Phy Variables (continued)*

ifOutMulticastPkts	Number of multicast frames transmitted error free.
ifOutBroadcastPkts	Total number of packets that higher-level protocols requested be transmitted, and that were addressed to a broadcast address at this sublayer, including those that were discarded or not sent.
dot3StatsFCSErrors	Number of frames with frame check errors, that is, there is an integral number of octets, but an incorrect Frame Check Sequence (FCS).
dot3StatsFrameTooLong	Number of received frames that were larger than the maximum size permitted.
etherStatsUndersizePkts	Total number of packets received that were less than 64 octets long (excluding framing bits, but including FCS octets) and were otherwise well formed.
etherStatsFragments	Total number of packets received that were less than 64 octets in length (excluding framing bits but including FCS octets) and had either a bad FCS with an integral number of octets (FCS Error) or a bad FCS with a nonintegral number of octets (Alignment Error). Note that it is entirely normal for etherStatsFragments to increment. This is because it counts both runts (which are normal occurrences due to collisions) and noise hits.
etherStatsPkts64Octets	Total number of packets (including bad packets) received that were 64 octets in length (excluding framing bits but including FCS octets).
etherStatsPkts65to127Octets	Total number of packets (including bad packets) received that were between 65 and 127 octets in length inclusive (excluding framing bits but including FCS octets).
etherStatsPkts128to255Octets	The total number of packets (including bad packets) received that were between 128 and 255 octets in length inclusive (excluding framing bits but including FCS octets).
etherStatsPkts256to511Octets	Total number of packets (including bad packets) received that were between 256 and 511 octets in length inclusive (excluding framing bits but including FCS octets).
etherStatsPkts512to1023Octets	Total number of packets (including bad packets) received that were between 512 and 1023 octets in length inclusive (excluding framing bits but including FCS octets).
etherStatsPkts1024to1518Octets	Total number of packets (including bad packets) received that were between 1024 and 1518 octets in length inclusive (excluding framing bits but including FCS octets).
etherStatsBroadcastPkts	Total number of good packets received that were directed to the broadcast address. Note that this does not include multicast packets.
etherStatsMulticastPkts	Total number of good packets received that were directed to a multicast address. Note that this number does not include packets directed to the broadcast address.
etherStatsOversizePkts	Total number of packets received that were longer than 1518 octets (excluding framing bits, but including FCS octets) and were otherwise well formed.

Table 5-24 *TXP_MR_10G, TXP_MR_10E, TXP_MR_10E_C, or TXP_MR_10E_L Card GE LAN Phy Variables (continued)*

etherStatsJabbers	Total number of packets received that were longer than 1518 octets (excluding framing bits, but including FCS octets), and had either a bad FCS with an integral number of octets (FCS Error) or a bad FCS with a nonintegral number of octets (Alignment Error).
etherStatsOctets	Total number of octets of data (including those in bad packets) received on the network (excluding framing bits but including FCS octets).
etherStatsCRCAlignErrors	Total number of packets received that had a length (excluding framing bits, but including FCS octets) of between 64 and 1518 octets, inclusive, but had either a bad FCS with an integral number of octets (FCS Error) or a bad FCS with a nonintegral number of octets (Alignment Error).
rxPauseFrames	Number of received IETF 802.x pause frames.
rxControlFrames	Number of MAC control frames passed by the MAC sublayer to the MAC control sublayer.
rxUnknownOpcodeFrames	Number of MAC control frames received that contain an opcode that is not supported by the device.

- Step 6** From the Alarm Type drop-down list, indicate whether the event will be triggered by the rising threshold, the falling threshold, or both the rising and falling thresholds.
- Step 7** From the Sample Type drop-down list, choose either **Relative** or **Absolute**. Relative restricts the threshold to use the number of occurrences in the user-set sample period. Absolute sets the threshold to use the total number of occurrences, regardless of time period.
- Step 8** Type in an appropriate number of seconds for the Sample Period.
- Step 9** Type in the appropriate number of occurrences for the Rising Threshold.
- For a rising type of alarm, the measured value must move from below the falling threshold to above the rising threshold. For example, if a network is running below a rising threshold of 1000 collisions every 15 seconds and a problem causes 1001 collisions in 15 seconds, the excess occurrences trigger an alarm.
- Step 10** Enter the appropriate number of occurrences in the Falling Threshold field. In most cases a falling threshold is set lower than the rising threshold.
- A falling threshold is the counterpart to a rising threshold. When the number of occurrences is above the rising threshold and then drops below a falling threshold, it resets the rising threshold. For example, when the network problem that caused 1001 collisions in 15 seconds subsides and creates only 799 collisions in 15 seconds, occurrences fall below a falling threshold of 800 collisions. This resets the rising threshold so that if network collisions again spike over a 1000 per 15-second period, an event again triggers when the rising threshold is crossed. An event is triggered only the first time a rising threshold is exceeded (otherwise, a single network problem might cause a rising threshold to be exceeded multiple times and cause a flood of events).
- Step 11** Click **OK**.
- Step 12** To view all RMON thresholds, click **Show All RMON thresholds**. If not, continue with [Step 13](#)
- Step 13** Return to your originating procedure (NTP).

DLP-G301 Provision the 10G Multirate Transponder Trunk Port Alarm and TCA Thresholds

Purpose	This task provisions the TXP_MR_10G, TXP_MR_10E, TXP_MR_10E_C, or TXP_MR_10E_L trunk port alarm and threshold cross alert (TCA) thresholds.
Tools/Equipment	None
Prerequisite Procedures	DLP-G46 Log into CTC, page 2-25
Required/As Needed	As needed
Onsite/Remote	Onsite or remote
Security Level	Provisioning or higher

- Step 1** In node view (single-shelf mode) or shelf view (multishelf view), double-click the TXP_MR_10G, TXP_MR_10E, TXP_MR_10E_C, or TXP_MR_10E_L card where you want to change the trunk port alarm and TCA settings.
- Step 2** Click the **Provisioning > Optics Thresholds** tabs.
- Step 3** Under Types, verify that the TCA radio button is checked. If not, check it, then click **Refresh**.
- Step 4** Referring to [Table 5-25](#), provision the trunk port (Port 2) TCA thresholds for RX Power High, RX Power Low, TX Power High, and TX Power Low.



Note You must modify 15 Min and 1 Day independently. To do so, choose the appropriate radio button and click **Refresh**.



Note Do not modify the Laser Bias parameters.

Table 5-25 10G Multirate Transponder Trunk Port TCA Thresholds

Card	TCA RX Power High	TCA RX Power Low	TCA TX Power High	TCA TX Power Low
TXP_MR_10G	-8 dBm	-22 dBm	7 dBm	-1 dBm
TXP_MR_10E	-9 dBm	-18 dBm	9 dBm	0 dBm
TXP_MR_10E_C				
TXP_MR_10E_L				

- Step 5** Click **Apply**.
- Step 6** Under Types, click the **Alarm** radio button and click **Refresh**.
- Step 7** Referring to [Table 5-26](#), provision the trunk port (Port 2) Alarm thresholds for RX Power High, RX Power Low, TX Power High, and TX Power Low.



Note You must modify 15 Min and 1 Day independently. To do so, choose the appropriate radio button and click **Refresh**.

Table 5-26 10G Multirate Transponder Trunk Port Alarm Thresholds

Card	Alarm RX Power High	Alarm RX Power Low	Alarm TX Power High	Alarm TX Power Low
TXP_MR_10G	-8 dBm	-24 dBm	4 dBm	2 dBm
TXP_MR_10E	-8 dBm	-20 dBm	7 dBm	3 dBm
TXP_MR_10E_C				
TXP_MR_10E_L				

- Step 8** Click **Apply**.
- Step 9** Return to your originating procedure (NTP).

DLP-G302 Provision the 10G Multirate Transponder Client Port Alarm and TCA Thresholds

Purpose	This task provisions the client port alarm and TCA thresholds for the TXP_MR_10G, TXP_MR_10E, TXP_MR_10E_C, and TXP_MR_10E_L cards.
Tools/Equipment	None
Prerequisite Procedures	DLP-G278 Provision the Optical Line Rate, page 5-9 DLP-G46 Log into CTC, page 2-25
Required/As Needed	Required
Onsite/Remote	Onsite or remote
Security Level	Provisioning or higher

- Step 1** In node view (single-shelf mode) or shelf view (multishelf view), double-click the TXP_MR_10G, TXP_MR_10E, TXP_MR_10E_C, or TXP_MR_10E_L card where you want to change the client port alarm and TCA settings.
- Step 2** Click the **Provisioning > Optics Thresholds** tabs. The TCA thresholds are shown by default.
- Step 3** Under Types, verify that the TCA radio button is checked. If not, check it, then click **Refresh**.
- Step 4** Referring to [Table 5-27](#), provision the Port 1 (Client) TCA thresholds for RX Power High, RX Power Low, TX Power High, and TX Power Low based on the client interface at the other end. For additional information about client SFP and XFP interfaces, also known as PPMs, refer to the “Hardware Specifications” appendix in the *Cisco ONS 15454 DWDM Reference Manual*.



Note You must modify 15 Min and 1 Day independently. To do so, choose the appropriate radio button and click **Refresh**.



Note Do not modify the Laser Bias parameters.



Note Pluggable port rates can be viewed on the Provisioning > Pluggable Port Modules tabs.

Table 5-27 *TXP_MR_10G, TXP_MR_10E, TXP_MR_10E_C, or TXP_MR_10E_L Card Client Interface TCA Thresholds*

Pluggable Port Rate	Pluggable Port Module (XFP)	TCA RX Power High	TCA RX Power Low	TCA TX Power High	TCA TX Power Low
SONET (or SDH)	TXP_MR_10E uses ONS-XC-10G-S1 TXP_MR_10G (XFP not present)	-1	-11	5	-12
10G Ethernet LAN Phy	TXP_MR_10E uses ONS-XC-10G-S1 TXP_MR_10G (XFP not present)	1	-14	5	-12
10G Ethernet WAN PHY	TXP_MR_10E uses ONS-XC-10G-S1 TXP_MR_10G (XFP not present)	1	-14	5	-12
10G Fibre Channel	TXP_MR_10E uses ONS-XC-10G-S1 TXP_MR_10G (XFP not present)	1	-14	5	-12

Step 5 Click **Apply**.

Step 6 Under Types, click the **Alarm** radio button and click **Refresh**.

Step 7 Referring to [Table 5-28](#), provision the Port 1 (Client) Alarm thresholds for RX Power High, RX Power Low, TX Power High, and TX Power Low based on the client interface that is provisioned.



Note You must modify 15 Min and 1 Day independently. To do so, choose the appropriate radio button and click **Refresh**.

Table 5-28 *TXP_MR_10G, TXP_MR_10E, TXP_MR_10E_C, or TXP_MR_10E_L Card Client Interface Alarm Thresholds*

Pluggable Port Rate	Pluggable Port Module (XFP)	Alarm RX Power High	Alarm RX Power Low	Alarm TX Power High	Alarm TX Power Low
SONET (or SDH)	TXP_MR_10E uses ONS-XC-10G-S1 TXP_MR_10G (XFP not present)	2	-14	2	-9
10G Ethernet LAN Phy	TXP_MR_10E uses ONS-XC-10G-S1 TXP_MR_10G (XFP not present)	4	-17	2	-9
10G Ethernet WAN PHY	TXP_MR_10E uses ONS-XC-10G-S1 TXP_MR_10G (XFP not present)	4	-17	2	-9
10G Fibre Channel	TXP_MR_10E uses ONS-XC-10G-S1 TXP_MR_10G (XFP not present)	4	-17	2	-9

Step 8 Click **Apply**.

Step 9 Return to your originating procedure (NTP).

DLP-G221 Change the 10G Multirate Transponder OTN Settings

Purpose	This task changes the line OTN settings for the TXP_MR_10G, TXP_MR_10E, TXP_MR_10E_C, and TXP_MR_10E_L transponder cards.
Tools/Equipment	None
Prerequisite Procedures	DLP-G46 Log into CTC, page 2-25
Required/As Needed	As needed
Onsite/Remote	Onsite or remote
Security Level	Provisioning or higher

Step 1 In node view (single-shelf mode) or shelf view (multishelf view), double-click the TXP_MR_10G, TXP_MR_10E, TXP_MR_10E_C, or TXP_MR_10E_L card where you want to change the OTN settings.

Step 2 Click the **Provisioning > OTN** tabs, then click one of the following subtabs: **OTN Lines**, **G.709 Thresholds**, **FEC Thresholds**, or **Trail Trace Identifier**.

Step 3 Modify any of the settings described in Tables [5-29](#) through [5-32](#).



Note You must modify Near End and Far End independently; 15 Min and 1 Day independently; and SM and PM independently. To do so, choose the appropriate radio button and click **Refresh**.

Table 5-29 describes the values on the Provisioning > OTN > OTN Lines tab.

Table 5-29 *TXP_MR_10G, TXP_MR_10E, TXP_MR_10E_C, or TXP_MR_10E_L Card OTN Lines Settings*

Parameter	Description	Options
Port	(Display only) Displays the port number and optional name.	2
G.709 OTN	Sets the OTN lines according to ITU-T G.709. Check the box to enable.	<ul style="list-style-type: none"> • Enable • Disable
FEC	Sets the OTN lines FEC mode. FEC mode can be Disabled, Enabled, or, for the TXP_MR_10E, Enhanced FEC mode can be enabled to provide greater range and lower bit error rate. For TXP_MR_10E cards, Standard is the same as enabling FEC.	<ul style="list-style-type: none"> • Enable—(TXP_MR_10G only) FEC is on. • Disable—FEC is off. • Standard—(TXP_MR_10E only) Standard FEC is on. • Enhanced—(TXP_MR_10E only) Enhanced FEC is on.
SD BER	Sets the signal degrade bit error rate.	<ul style="list-style-type: none"> • 1E-5 • 1E-6 • 1E-7 • 1E-8 • 1E-9
SF BER	(Display only) Indicates the signal fail bit error rate.	<ul style="list-style-type: none"> • 1E-5
Asynch/Synch Mapping	(TXP_MR_10E only) Sets how the ODUk (client payload) is mapped to the optical channel (OTUk).	<ul style="list-style-type: none"> • Asynch mapping • Synch mapping

Table 5-30 describes the values on the Provisioning > OTN > G.709 Thresholds tab.

Table 5-30 *TXP_MR_10G, TXP_MR_10E, TXP_MR_10E_C, or TXP_MR_10E_L Card ITU-T G.709 Threshold Settings*

Parameter	Description	Options
Port	(Display only) Displays the port number and optional name.	2
ES	Severely errored seconds. Two types of thresholds can be asserted. Selecting the SM (OTUk) radio button selects FEC, overhead management, and PM using OTUk. Selecting the PM radio button selects path PM using ODUk.	<p>Numeric. Threshold display options include:</p> <ul style="list-style-type: none"> • Direction—Near End or Far End • Interval—15 Min (minutes) or 1 day • Types—SM (OTUk) or PM (ODUk) <p>Choose an option in each category and click Refresh.</p> <p>Note SM (OTUk) is the ITU-T G.709 optical channel transport unit order of k overhead frame used for management and performance monitoring. PM (ODUk) is the ITU-T G.709 optical channel data unit order of k overhead frame unit used for path performance monitoring.</p>
SES	Severely errored seconds	<p>Numeric. Threshold display options include:</p> <ul style="list-style-type: none"> • Direction—Near End or Far End • Interval—15 Min (minutes) or 1 day • Types—SM (OTUk) or PM (ODUk) <p>Choose an option in each category and click Refresh.</p>
UAS	Unavailable seconds	<p>Numeric. Threshold display options include:</p> <ul style="list-style-type: none"> • Direction—Near End or Far End • Interval—15 Min (minutes) or 1 day • Types—SM (OTUk) or PM (ODUk) <p>Choose an option in each category and click Refresh.</p>

Table 5-30 *TXP_MR_10G, TXP_MR_10E, TXP_MR_10E_C, or TXP_MR_10E_L Card ITU-T G.709 Threshold Settings (continued)*

Parameter	Description	Options
BBE	Background block errors	Numeric. Threshold display options include: <ul style="list-style-type: none"> • Direction—Near End or Far End • Interval—15 Min (minutes) or 1 day • Types—SM (OTUk) or PM (ODUk) Choose an option in each category and click Refresh .
FC	Failure counter	Numeric. Threshold display options include: <ul style="list-style-type: none"> • Direction—Near End or Far End • Interval—15 Min (minutes) or 1 day • Types—SM (OTUk) or PM (ODUk) Choose an option in each category and click Refresh .

[Table 5-31](#) describes the values on the Provisioning > OTN > FEC Thresholds tab.

Table 5-31 *TXP_MR_10G, TXP_MR_10E, TXP_MR_10E_C, or TXP_MR_10E_L Card FEC Threshold Settings*

Parameter	Description	Options
Port	(Display only) Displays the port number and optional name.	2
Bit Errors Corrected	Displays the number of bit errors corrected during the selected time period.	Numeric display. Can be set for 15-minute or one-day intervals.
Uncorrectable Words	Displays the number of uncorrectable words in the selected time period.	Numeric display. Can be set for 15-minute or one-day intervals.

[Table 5-32](#) describes the values on the Provisioning > OTN > Trail Trace Identifier tab.

Table 5-32 *10G Multirate Transponder Trail Trace Identifier Settings*

Parameter	Description	Options
Port	Sets the port number.	<ul style="list-style-type: none"> • 1 • 2
Level	Sets the level.	<ul style="list-style-type: none"> • Section • Path
Received Trace Mode	Sets the trace mode.	<ul style="list-style-type: none"> • Off/None • Manual

Table 5-32 10G Multirate Transponder Trail Trace Identifier Settings (continued)

Parameter	Description	Options
Disable FDI on TTIM	If a Trace Identifier Mismatch on Section overhead alarm arises because of a J0 overhead string mismatch, no Forward Defect Indication (FDI) signal is sent to the downstream nodes if this box is checked.	<ul style="list-style-type: none"> Checked (FDI on TTIM is disabled) Unchecked (FDI on TTIM is not disabled)
Transmit	Displays the current transmit string; sets a new transmit string. You can click the button on the right to change the display. Its title changes, based on the current display mode. Click Hex to change the display to hexadecimal (button changes to ASCII); click ASCII to change the display to ASCII (button changes to Hex).	String of trace string size; trail trace identifier is 64 bytes in length.
Expected	Displays the current expected string; sets a new expected string. You can click the button on the right to change the display. Its title changes, based on the current display mode. Click Hex to change the display to hexadecimal (button changes to ASCII); click ASCII to change the display to ASCII (button changes to Hex).	String of trace string size
Received	(Display only) Displays the current received string. You can click Refresh to manually refresh this display, or check the Auto-refresh every 5 sec check box to keep this panel updated.	String of trace string size
Auto-refresh	If checked, automatically refreshes the display every 5 minutes.	Checked/unchecked (default)

Step 4 Click **Apply**.

Step 5 Return to your originating procedure (NTP).

NTP-G97 Modify the 4x2.5G Muxponder Card Line Settings and PM Parameter Thresholds

Purpose This procedure changes the line and threshold settings for the MXP_2.5G_10G, MXP_2.5G_10E, MXP_2.5G_10E_C, and MXP_2.5G_10E_L muxponder cards.

Tools/Equipment None

Prerequisite Procedures	NTP-G32 Install the Transponder and Muxponder Cards, page 3-50. DLP-G63 Install an SFP or XFP, page 3-52 DLP-G277 Provision a Multirate PPM, page 5-6 (if necessary) DLP-G278 Provision the Optical Line Rate, page 5-9 (if necessary)
Required/As Needed	As needed
Onsite/Remote	Onsite or remote
Security Level	Provisioning or higher

-
- Step 1** Complete the “[DLP-G46 Log into CTC](#)” task on page 2-25 at the node where you want to change the muxponder card settings. If you are already logged in, continue with [Step 2](#).
- Step 2** As needed, complete the “[NTP-G103 Back Up the Database](#)” procedure on page 13-2 to preserve the existing transmission settings.
- Step 3** Perform any of the following tasks as needed:
- [DLP-G222 Change the 4x2.5G Muxponder Card Settings, page 5-59](#)
 - [DLP-G223 Change the 4x2.5G Muxponder Line Settings, page 5-61](#)
 - [DLP-G224 Change the 4x2.5G Muxponder Section Trace Settings, page 5-64](#)
 - [DLP-G225 Change the 4x2.5G Muxponder Trunk Settings, page 5-65](#)
 - [DLP-G226 Change the 4x2.5G Muxponder SONET/SDH Line Thresholds Settings, page 5-68](#)
 - [DLP-G303 Provision the 4x2.5G Muxponder Trunk Port Alarm and TCA Thresholds, page 5-71](#)
 - [DLP-G304 Provision the 4x2.5G Muxponder Client Port Alarm and TCA Thresholds, page 5-73](#)
 - [DLP-G228 Change the 4x2.5G Muxponder Line OTN Settings, page 5-75](#)
 - [DLP-G369 Change the 4x2.5G Muxponder Trunk Wavelength Settings, page 5-67](#)
- Step 4** As needed, complete the “[NTP-G103 Back Up the Database](#)” procedure on page 13-2.
- Stop. You have completed this procedure.**
-

DLP-G222 Change the 4x2.5G Muxponder Card Settings

Purpose	This task changes the card settings for the MXP_2.5G_10G, MXP_2.5G_10E, MXP_2.5G_10E_C, and MXP_2.5G_10E_L muxponder cards, including payload type, termination mode, and wavelength.
Tools/Equipment	None
Prerequisite Procedures	DLP-G46 Log into CTC, page 2-25
Required/As Needed	As needed
Onsite/Remote	Onsite or remote
Security Level	Provisioning or higher

-
- Step 1** In node view (single-shelf mode) or shelf view (multishelf view), double-click the MXP_2.5G_10G, MXP_2.5G_10E, MXP_2.5G_10E_C, or MXP_2.5G_10E_L card where you want to change the card settings.

Step 2 Click the **Provisioning > Card** tabs.

Step 3 Modify any of the settings described in [Table 5-33](#).



Note Parameters shown in [Table 5-33](#) do not apply to all 4x2.5G muxponder cards. If the parameter or option does not apply, it is not shown in CTC.

Table 5-33 *MXP_2.5G_10G, MXP_2.5G_10E, MXP_2.5G_10E_C, or MXP_2.5G_10E_L Card Settings*

Parameter	Description	Options
Termination Mode	<p>Sets the mode of operation. Options that do not apply to a card do not display.</p> <p>The MXP_2.5G_10G card is based on SONET/SDH multiplexing. The transparent mode terminates and rebuilds the B1 byte (as well as other bytes) of the incoming OC-48/STM-16 signal. The B2 byte is not touched.</p> <p>The MXP_2.5G_10E, MXP_2.5G_10E_C, and MXP_2.5G_10E_L cards are fully transparent in transparent mode based on the OTN/ITU-T G.709 multiplexing scheme. It does not terminate the B1 byte or other bytes.</p> <p>It encapsulates OC-48/STM-16 bytes into ODU1 first, then multiplexes them into an OTU2.</p> <p>Refer to the “Card Reference” chapter in the e <i>Cisco ONS 15454 DWDM Reference Manual</i> for more details.</p>	<p>For ANSI platforms:</p> <ul style="list-style-type: none"> Transparent Section (MXP_2.5G_10E, MXP_2.5G_10E_C, and MXP_2.5G_10E_L only) Line (MXP_2.5G_10G only) <p>For ETSI platforms:</p> <ul style="list-style-type: none"> Transparent Multiplex Section (MXP_2.5G_10G, only) Regeneration Section (MXP_2.5G_10E, MXP_2.5G_10E_C, and MXP_2.5G_10E_L only)
AIS/Squelch	(MXP_2.5G_10E, MXP_2.5G_10E_C, and MXP_2.5G_10E_L only) Sets the transparent termination mode configuration.	<ul style="list-style-type: none"> Ais Squelch

Table 5-33 *MXP_2.5G_10G, MXP_2.5G_10E, MXP_2.5G_10E_C, or MXP_2.5G_10E_L Card Settings (continued)*

Parameter	Description	Options
Tunable Wavelengths	(Display only) Shows the supported wavelengths of the trunk port after the card is installed. For the MXP_2.5G_10E_C, or MXP_2.5G_10E_L cards, the first and last supported wavelength, frequency spacing, and number of supported wavelengths are shown in the format: <i>first wavelength-last wavelength-frequency spacing-number of supported wavelengths</i> . For example, the MXP_2.5G_10E_C card would show: 1529.55nm-1561.83nm-50GHz-82. The MXP_2.5G_10G and MXP_2.5G_10E show the four wavelengths supported by the card that is installed.	—

- Step 4** Click **Apply**.
- Step 5** Return to your originating procedure (NTP).

DLP-G223 Change the 4x2.5G Muxponder Line Settings

Purpose	This task changes the line settings for the MXP_2.5G_10G, MXP_2.5G_10E, MXP_2.5G_10E_C, and MXP_2.5G_10E_L muxponder cards.
Tools/Equipment	None
Prerequisite Procedures	DLP-G46 Log into CTC, page 2-25
Required/As Needed	As needed
Onsite/Remote	Onsite or remote
Security Level	Provisioning or higher

Step 1 In node view (single-shelf mode) or shelf view (multishelf view), double-click the MXP_2.5G_10G, MXP_2.5G_10E, MXP_2.5G_10E_C, or MXP_2.5G_10E_L card where you want to change the line settings.

Step 2 Click the **Provisioning > Line > SONET (ANSI)** or **SDH (ETSI)** tabs.



Note The SONET tab appears only if you have created a PPM for a given port.

Step 3 Modify any of the settings described in [Table 5-34](#).

**Note**

You must modify Near End and Far End independently; 15 Min and 1 Day independently; and Line and Section independently. To do so, choose the appropriate radio button and click **Refresh**.

Table 5-34 *MXP_2.5G_10G, MXP_2.5G_10E, MXP_2.5G_10E_C, or MXP_2.5G_10E_L Card Line Settings*

Parameter	Description	Options
Port	(Display only) Port number. Ports 1 to 4 are client ports (OC-48/STM-16). Port 5 is the DWDM trunk (OC-192/STM-64) that provides wavelength services. Client ports will not appear if the pluggable port module is not provisioned for it.	<ul style="list-style-type: none"> • 1 • 2 • 3 • 4 • 5 (Trunk) (MXP_2.5G_10G only)
Port Name	Provides the ability to assign the specified port a logical name.	<p>User-defined. Name can be up to 32 alphanumeric/special characters. Blank by default.</p> <p>See the “DLP-G104 Assign a Name to a Port” task on page 7-3.</p>
Admin State	Sets the port service state unless network conditions prevent the change. For more information about administrative states, refer to the “Administrative and Service States” appendix in the <i>Cisco ONS 15454 DWDM Reference Manual</i> .	<ul style="list-style-type: none"> • IS (ANSI) or Unlocked (ETSI) • IS,AINS (ANSI) or Unlocked,automaticInService (ETSI) • OOS,DSBLD (ANSI) or Locked,disabled (ETSI) • OOS,MT (ANSI) or Locked,maintenance (ETSI)
Service State	(Display only) Identifies the autonomously generated state that gives the overall condition of the port. Service states appear in the format: Primary State-Primary State Qualifier, Secondary State. For more information about service states, refer to the “Administrative and Service States” appendix in the <i>Cisco ONS 15454 DWDM Reference Manual</i> .	<ul style="list-style-type: none"> • IS-NR (ANSI) or Unlocked-enabled (ETSI) • OOS-AU,AINS (ANSI) or Unlocked-disabled, automaticInService (ETSI) • OOS-MA,DSBLD (ANSI) or Locked-enabled,disabled (ETSI) • OOS-MA,MT (ANSI) or Locked-enabled,maintenance (ETSI)
SF BER	Sets the signal fail bit error rate.	<ul style="list-style-type: none"> • 1E-3 • 1E-4 • 1E-5
SD BER	Sets the signal degrade bit error rate.	<ul style="list-style-type: none"> • 1E-5 • 1E-6 • 1E-7 • 1E-8 • 1E-9

Table 5-34 *MXP_2.5G_10G, MXP_2.5G_10E, MXP_2.5G_10E_C, or MXP_2.5G_10E_L Card Line Settings (continued)*

Parameter	Description	Options
ALS Mode	Sets the ALS function mode. The DWDM transmitter supports ALS according to ITU-T G.644 (06/99). ALS can be disabled or can be set for one of three mode options.	<ul style="list-style-type: none"> Disable (default): ALS is off; the laser is not automatically shut down when traffic outages (LOS) occur. Auto Restart: ALS is on; the laser automatically shuts down when traffic outages (LOS) occur. It automatically restarts when the conditions that caused the outage are resolved. Manual Restart: ALS is on; the laser automatically shuts down when traffic outages (LOS) occur. However, the laser must be manually restarted when conditions that caused the outage are resolved. Manual Restart for Test: Manually restarts the laser for testing.
AINS Soak	Sets the automatic in-service soak period. Double-click the time and use the up and down arrows to change settings.	<ul style="list-style-type: none"> Duration of valid input signal, in hh.mm format, after which the card becomes in service (IS) automatically 0 to 48 hours, 15-minute increments
Type	Sets the optical transport type.	<ul style="list-style-type: none"> SONET SDH
SyncMsgIn	Enables synchronization status messages (S1 byte), which allow the node to choose the best timing source. (This parameter does not appear for the MXP_2.5G_10E trunk port.)	Checked or unchecked
ProvidesSync	Sets the ProvidesSync card parameter. If checked, the card is provisioned as an NE timing reference. (This parameter does not appear for the MXP_2.5G_10E trunk port.)	Checked or unchecked
Reach	Displays the optical reach distance of the client port.	Options: ANSI/ETSI <ul style="list-style-type: none"> Autoprovision/Autoprovision (default) SR SR 1/I-1—Short reach up to 2-km distance IR 1/S1—Intermediate reach, up to 15-km distance IR 2/S2—Intermediate reach up to 40-km distance LR 1/L1—long reach, up to 40-km distance LR 2/L2—long reach, up to 80-km distance LR 3/L3—long reach, up to 80-km distance
Wavelength	Displays the wavelength of the client port.	<ul style="list-style-type: none"> First Tunable Wavelength Further wavelengths: 850 nm through 1560.61 nm 100-GHz ITU spacing CWDM spacing

- Step 4** Click **Apply**.
- Step 5** Return to your originating procedure (NTP).

DLP-G224 Change the 4x2.5G Muxponder Section Trace Settings

Purpose	This task changes the section trace settings for the MXP_2.5G_10G, MXP_2.5G_10E, MXP_2.5G_10E_C, and MXP_2.5G_10E_L muxponder cards.
Tools/Equipment	None
Prerequisite Procedures	DLP-G46 Log into CTC, page 2-25
Required/As Needed	As needed
Onsite/Remote	Onsite or remote
Security Level	Provisioning or higher



Note The Section Trace tab appears only if you have created a PPM for the card.

- Step 1** In node view (single-shelf mode) or shelf view (multishelf view), double-click the MXP_2.5G_10G, MXP_2.5G_10E, MXP_2.5G_10E_C, or MXP_2.5G_10E_L card where you want to change the section trace settings.
- Step 2** Click the **Provisioning > Line > Section Trace** tabs.
- Step 3** Modify any of the settings described in [Table 5-35](#).

Table 5-35 *MXP_2.5G_10G, MXP_2.5G_10E, MXP_2.5G_10E_C, or MXP_2.5G_10E_L Card Section Trace Settings*

Parameter	Description	Options
Port	Sets the port number.	<ul style="list-style-type: none"> 1 2 3 4 5 (Trunk; MXP_2.5G_10G only)
Received Trace Mode	Sets the trace mode.	<ul style="list-style-type: none"> Off/None Manual
Disable AIS/RDI on TIM-S	If an TIM on Section overhead alarm arises because of a J0 overhead string mismatch, no alarm indication signal is sent to downstream nodes if this box is checked.	<ul style="list-style-type: none"> Checked (AIS/RDI on TIM-S is disabled) Unchecked (AIS/RDI on TIM-S is not disabled)
Transmit Section Trace String Size	Sets the trace string size. Select either radio button.	<ul style="list-style-type: none"> 1 byte 16 byte

Table 5-35 *MXP_2.5G_10G, MXP_2.5G_10E, MXP_2.5G_10E_C, or MXP_2.5G_10E_L Card Section Trace Settings (continued)*

Parameter	Description	Options
Transmit	Displays the current transmit string; sets a new transmit string. You can click the button on the right to change the display. Its title changes, based on the current display mode. Click Hex to change the display to hexadecimal (button changes to ASCII); click ASCII to change the display to ASCII (button changes to Hex).	String of trace string size
Expected	Displays the current expected string; sets a new expected string. You can click the button on the right to change the display. Its title changes, based on the current display mode. Click Hex to change the display to hexadecimal (button changes to ASCII); click ASCII to change the display to ASCII (button changes to Hex).	String of trace string size
Received	(Display only) Displays the current received string. You can click Refresh to manually refresh this display, or check the Auto-refresh every 5 sec check box to keep this panel updated.	String of trace string size
Auto-refresh	If checked, automatically refreshes the display every 5 minutes.	Checked/unchecked (default)

Step 4 Click **Apply**.

Step 5 Return to your originating procedure (NTP).

DLP-G225 Change the 4x2.5G Muxponder Trunk Settings

Purpose	This task provisions the trunk settings for the MXP_2.5G_10E, MXP_2.5G_10E_C, and MXP_2.5G_10E_L muxponder cards.
Tools/Equipment	None
Prerequisite Procedures	DLP-G46 Log into CTC, page 2-25
Required/As Needed	As needed
Onsite/Remote	Onsite or remote
Security Level	Provisioning or higher



Note This task does not apply to the MXP_2.5G_10G card.

- Step 1** In node view (single-shelf mode) or shelf view (multishelf view), double-click the MXP_2.5G_10E, MXP_2.5G_10E_C, or MXP_2.5G_10E_L card where you want to change the section trace settings.
- Step 2** Click the **Provisioning > Line > Trunk** tabs.
- Step 3** Modify any of the settings described in [Table 5-36](#).

Table 5-36 MXP_2.5G_10E, MXP_2.5G_10E_C, or MXP_2.5G_10E_L Card Trunk Settings

Parameter	Description	Options
Port	(Display only) Displays the port number. Port 5 is the DWDM trunk (OC-192/STM-64) that provides wavelength services.	5 (Trunk)
Port Name	Provides the ability to assign the specified port a logical name.	User-defined. Name can be up to 32 alphanumeric/special characters. Blank by default. See the “DLP-G104 Assign a Name to a Port” task on page 7-3.
Admin State	Sets the port service state unless network conditions prevent the change. For more information about administrative states, refer to the “Administrative and Service States” appendix in the <i>Cisco ONS 15454 DWDM Reference Manual</i> .	<ul style="list-style-type: none"> • IS (ANSI) or Unlocked (ETSI) • IS,AINS (ANSI) or Unlocked,automaticInService (ETSI) • OOS,DSBLD (ANSI) or Locked,disabled (ETSI) • OOS,MT (ANSI) or Locked,maintenance (ETSI)
Service State	(Display only) Identifies the autonomously generated state that gives the overall condition of the port. Service states appear in the format: Primary State-Primary State Qualifier, Secondary State. For more information about service states, refer to the “Administrative and Service States” appendix in the <i>Cisco ONS 15454 DWDM Reference Manual</i> .	<ul style="list-style-type: none"> • IS-NR (ANSI) or Unlocked-enabled (ETSI) • OOS-AU,AINS (ANSI) or Unlocked-disabled, automaticInService (ETSI) • OOS-MA,DSBLD (ANSI) or Locked-enabled,disabled (ETSI) • OOS-MA,MT (ANSI) or Locked-enabled,maintenance (ETSI)

Table 5-36 MXP_2.5G_10E, MXP_2.5G_10E_C, or MXP_2.5G_10E_L Card Trunk Settings (continued)

Parameter	Description	Options
ALS Mode	Sets the ALS function mode. The DWDM transmitter supports ALS according to ITU-T G.644 (06/99). ALS can be disabled or can be set for one of three mode options.	<ul style="list-style-type: none"> Disabled (default): ALS is off; the laser is not automatically shut down when traffic outages (LOS) occur. Auto Restart: ALS is on; the laser automatically shuts down when traffic outages (LOS) occur. It automatically restarts when the conditions that caused the outage are resolved. Manual Restart: ALS is on; the laser automatically shuts down when traffic outages (LOS) occur. However, the laser must be manually restarted when conditions that caused the outage are resolved. Manual Restart for Test: Manually restarts the laser for testing.
AINS Soak	(OC-N and STM-N payloads only) Sets the automatic in-service soak period.	<ul style="list-style-type: none"> Duration of valid input signal, in hh.mm format, after which the card becomes in service (IS) automatically 0 to 48 hours, 15-minute increments

Step 4 Click **Apply**.

Step 5 Return to your originating procedure (NTP).

DLP-G369 Change the 4x2.5G Muxponder Trunk Wavelength Settings

Purpose	This task changes the trunk wavelength settings for the MXP_2.5G_10G, MXP_2.5G_10E, MXP_2.5G_10E_C, and MXP_2.5G_10E_L cards.
Tools/Equipment	None
Prerequisite Procedures	DLP-G46 Log into CTC, page 2-25
Required/As Needed	As needed
Onsite/Remote	Onsite or remote
Security Level	Provisioning or higher

- Step 1** In node view (single-shelf mode) or shelf view (multishelf view), double-click the MXP_2.5G_10G, MXP_2.5G_10E, MXP_2.5G_10E_C, and MXP_2.5G_10E_L card where you want to change the trunk wavelength settings.
- Step 2** Click the **Provisioning > Line > Wavelength Trunk Settings** tabs.
- Step 3** Modify any of the settings for the Wavelength Trunk Settings tab as described in [Table 5-37](#).

Table 5-37 *MXP_2.5G_10G, MXP_2.5G_10E, MXP_2.5G_10E_C, and MXP_2.5G_10E_L Card Wavelength Trunk Settings*

Parameter	Description	Options
Port	(Display only) Displays the port number.	5 (Trunk)
Band	(Display only) Indicates the wavelength band available from the card that is installed. If the card is preprovisioned, the field can be provisioned to the band of the card that will be installed.	<ul style="list-style-type: none"> C—The C-band wavelengths are available in the Wavelength field. L—The L-band wavelengths are available in the Wavelength field.
Even/Odd	Sets the wavelengths available for provisioning for MXP_2.5G_10E_C and MXP_2.5G_10E_L cards. (This field does not apply to MXP_2.5G_10G or MXP_2.5G_10E cards.)	<ul style="list-style-type: none"> Even—Displays even C-band or L-band wavelengths in the Wavelength field. Odd—Displays odd C-band or L-band wavelengths in the Wavelength field.
Wavelength	The wavelength provisioned for the trunk.	<ul style="list-style-type: none"> First Tunable Wavelength Further wavelengths in 100-GHz ITU-T C-band or L-band spacing, depending on the card that is installed. For MXP_2.5G_10G and MXP_2.5G_10E cards, the wavelengths carried by the card are identified with two asterisks. If the card is not installed, all wavelengths appear with a dark grey background.

Step 4 Click **Apply**.

Step 5 Return to your originating procedure (NTP).

DLP-G226 Change the 4x2.5G Muxponder SONET/SDH Line Thresholds Settings

Purpose	This task changes the SONET (ANSI) or SDH (ETSI) line threshold settings for the MXP_2.5G_10G, MXP_2.5G_10E, MXP_2.5G_10E_C, and MXP_2.5G_10E_L muxponder cards.
Tools/Equipment	None
Prerequisite Procedures	DLP-G46 Log into CTC, page 2-25
Required/As Needed	As needed
Onsite/Remote	Onsite or remote
Security Level	Provisioning or higher

Step 1 In node view (single-shelf mode) or shelf view (multishelf view), double-click the MXP_2.5G_10G, MXP_2.5G_10E, MXP_2.5G_10E_C, or MXP_2.5G_10E_L card where you want to change the line threshold settings.

Step 2 Click the **Provisioning > Line Thresholds** tabs.

Step 3 Modify any of the settings described in [Table 5-38](#).



Note In [Table 5-38](#), some parameter tabs or selections do not always apply to all 4x2.5G muxponder cards. If the tabs or selections do not apply, they do not appear in CTC.

Table 5-38 *MPX_2.5G_10G, MPX_2.5G_10E, MPX_2.5G_10E_C, or MPX_2.5G_10E_LCard Line Threshold Settings*

Parameter	Description	Options - ONS 15454	Options - ONS 15454 SDH
Port	(Display only) Port number	<ul style="list-style-type: none"> • 1 • 2 • 3 • 4 • 5 (MPX_2.5G_10G only) 	<ul style="list-style-type: none"> • 1 • 2 • 3 • 4 • 5 (MPX_2.5G_10G only)
EB	Path Errored Block indicates that one or more bits are in error within a block	Numeric. Threshold display options include: <ul style="list-style-type: none"> • Direction—Near End or Far End • Interval—15 Min (minutes) or 1 day • Types—Line or Section (near end only) Choose an option in each category and click Refresh .	Numeric. Threshold display options include: <ul style="list-style-type: none"> • Direction—Near End or Far End • Interval—15 Min (minutes) or 1 day • Types—Multiplex Section or Regeneration Section (near end only) Choose an option in each category and click Refresh .
CV	Coding violations	Numeric. Threshold display options include: <ul style="list-style-type: none"> • Direction—Near End or Far End • Interval—15 Min (minutes) or 1 day • Types—Line or Section (near end only) Choose an option in each category and click Refresh .	Numeric. Threshold display options include: <ul style="list-style-type: none"> • Direction—Near End or Far End • Interval—15 Min (minutes) or 1 day • Types—Multiplex Section or Regeneration Section (near end only) Choose an option in each category and click Refresh .
ES	Errored seconds	Numeric. Threshold display options include: <ul style="list-style-type: none"> • Direction—Near End or Far End • Interval—15 Min (minutes) or 1 day • Types—Line or Section (near end only) Choose an option in each category and click Refresh .	Numeric. Threshold display options include: <ul style="list-style-type: none"> • Direction—Near End or Far End • Interval—15 Min (minutes) or 1 day • Types—Multiplex Section or Regeneration Section (near end only) Choose an option in each category and click Refresh .

Table 5-38 MXP_2.5G_10G, MXP_2.5G_10E, MXP_2.5G_10E_C, or MXP_2.5G_10E_LCard Line Threshold Settings

Parameter	Description	Options - ONS 15454	Options - ONS 15454 SDH
SES	Severely errored seconds	Numeric. Threshold display options include: <ul style="list-style-type: none"> Direction—Near End or Far End Interval—15 Min (minutes) or 1 day Types—Line or Section (near end only) Choose an option in each category and click Refresh .	Numeric. Threshold display options include: <ul style="list-style-type: none"> Direction—Near End or Far End Interval—15 Min (minutes) or 1 day Types—Multiplex Section or Regeneration Section (near end only) Choose an option in each category and click Refresh .
SEFS	(Near End Section or Regeneration Section only) Severely errored framing seconds	Numeric. Threshold display options include: <ul style="list-style-type: none"> Direction—Near End or Far End Interval—15 Min (minutes) or 1 day Types—Line or Section (near end only) Choose an option in each category and click Refresh .	Numeric. Threshold display options include: <ul style="list-style-type: none"> Direction—Near End or Far End Interval—15 Min (minutes) or 1 day Types—Multiplex Section or Regeneration Section (near end only) Choose an option in each category and click Refresh .
BBE	Background block errors	Numeric. Threshold display options include: <ul style="list-style-type: none"> Direction—Near End or Far End Interval—15 Min (minutes) or 1 day Types—Line or Section (near end only) Choose an option in each category and click Refresh .	Numeric. Threshold display options include: <ul style="list-style-type: none"> Direction—Near End or Far End Interval—15 Min (minutes) or 1 day Types—Multiplex Section or Regeneration Section (near end only) Choose an option in each category and click Refresh .
FC	(Line or Multiplex Section only) Failure count	Numeric. Threshold display options include: <ul style="list-style-type: none"> Direction—Near End or Far End Interval—15 Min (minutes) or 1 day Types—Line or Section (near end only) Choose an option in each category and click Refresh .	Numeric. Threshold display options include: <ul style="list-style-type: none"> Direction—Near End or Far End Interval—15 Min (minutes) or 1 day Types—Multiplex Section or Regeneration Section (near end only) Choose an option in each category and click Refresh .

Table 5-38 MXP_2.5G_10G, MXP_2.5G_10E, MXP_2.5G_10E_C, or MXP_2.5G_10E_L Card Line Threshold Settings

Parameter	Description	Options - ONS 15454	Options - ONS 15454 SDH
UAS	(Line or Multiplex Section only) Unavailable seconds	Numeric. Threshold display options include: <ul style="list-style-type: none"> • Direction—Near End or Far End • Interval—15 Min (minutes) or 1 day • Types—Line or Section (near end only) Choose an option in each category and click Refresh .	Numeric. Threshold display options include: <ul style="list-style-type: none"> • Direction—Near End or Far End • Interval—15 Min (minutes) or 1 day • Types—Multiplex Section or Regeneration Section (near end only) Choose an option in each category and click Refresh .

Step 4 Click **Apply**.

Step 5 Return to your originating procedure (NTP).

DLP-G303 Provision the 4x2.5G Muxponder Trunk Port Alarm and TCA Thresholds

Purpose	This task changes the MXP_2.5G_10G, MXP_2.5G_10E, MXP_2.5G_10E_C, and MXP_2.5G_10E_L trunk port alarm and TCA thresholds.
Tools/Equipment	None
Prerequisite Procedures	DLP-G46 Log into CTC, page 2-25
Required/As Needed	As needed
Onsite/Remote	Onsite or remote
Security Level	Provisioning or higher

Step 1 In node view (single-shelf mode) or shelf view (multishelf view), double-click the MXP_2.5G_10G, MXP_2.5G_10E, MXP_2.5G_10E_C, or MXP_2.5G_10E_L card where you want to change the trunk port alarm and TCA settings.

Step 2 Click the **Provisioning > Optics Thresholds** tabs.

Step 3 Select **TCA** (if not already selected), a **15 Min** or **1 Day** PM interval radio button and then click **Refresh**.



Note You must modify 15 Min and 1 Day independently. To do so, choose the appropriate radio button and click **Refresh**.

Step 4 Referring to [Table 5-39](#), provision the trunk port (Port 5) TCA thresholds for RX Power High, RX Power Low, TX Power High, and TX Power Low.



Note Do not modify the Laser Bias parameters.

Table 5-39 *MXP_2.5G_10G, MXP_2.5G_10E, MXP_2.5G_10E_C, or MXP_2.5G_10E_L Trunk Port TCA Thresholds*

Card	TCA RX Power High	TCA RX Power Low	TCA TX Power High	TCA TX Power Low
MXP_2.5G_10G	-8 dBm	-22 dBm	7 dBm	-1 dBm
MXP_2.5G_10E	-9 dBm	-18 dBm	9 dBm	0 dBm
MXP_2.5G_10E_C	-9 dBm	-18 dBm	9 dBm	0 dBm
MXP_2.5G_10E_L	-9 dBm	-18 dBm	9 dBm	0 dBm

Step 5 Click **Apply**.

Step 6 Under Types, click the **Alarm** radio button and click **Refresh**.

Step 7 Referring to [Table 5-40](#), provision the trunk port (Port 5) Alarm thresholds for RX Power High, RX Power Low, TX Power High, and TX Power Low.



Note Do not modify the Laser Bias parameters.



Note You must modify 15 Min and 1 Day independently. To do so, choose the appropriate radio button and click **Refresh**.

Table 5-40 *MXP_2.5G_10G, MXP_2.5G_10E, MXP_2.5G_10E_C, or MXP_2.5G_10E_L Trunk Port Alarm Thresholds*

Card	Alarm RX Power High	Alarm RX Power Low	Alarm TX Power High	Alarm TX Power Low
MXP_2.5G_10G	-8 dBm	-24 dBm	4 dBm	2 dBm
MXP_2.5G_10E	-8 dBm	-20 dBm	7 dBm	3 dBm
MXP_2.5G_10E_C	-8 dBm	-20 dBm	7 dBm	3 dBm
MXP_2.5G_10E_L	-8 dBm	-20 dBm	7 dBm	3 dBm

Step 8 Click **Apply**.

Step 9 Return to your originating procedure (NTP).

DLP-G304 Provision the 4x2.5G Muxponder Client Port Alarm and TCA Thresholds

Purpose	This task provisions the client port alarm and TCA thresholds for the MXP_2.5G_10G, MXP_2.5G_10E, MXP_2.5G_10E_C, and MXP_2.5G_10E_L cards.
Tools/Equipment	None
Prerequisite Procedures	DLP-G278 Provision the Optical Line Rate, page 5-9 DLP-G46 Log into CTC, page 2-25
Required/As Needed	Required
Onsite/Remote	Onsite or remote
Security Level	Provisioning or higher

- Step 1** In node view (single-shelf mode) or shelf view (multishelf view), double-click the MXP_2.5G_10G, MXP_2.5G_10E, MXP_2.5G_10E_C, or MXP_2.5G_10E_L card where you want to change the client port alarm and TCA settings.
- Step 2** Click the **Provisioning > Optics Thresholds** tabs. The TCA thresholds are shown by default.
- Step 3** Referring to [Table 5-41](#), provision the client Port *N* (where *N* = 1 through 4) TCA thresholds for RX Power High, RX Power Low, TX Power High, and TX Power Low based on the client interface at the other end.



Note

The hardware device that plugs into a TXP or MXP card faceplate to provide a fiber interface to the card is called a Small Form-factor Pluggable (SFP or XFP). In Cisco Transport Controller (CTC), SFPs and XFPs are called PPMs. SFPs/XFPs are hot-swappable input/output devices that plug into a TXP, MXP, or line card port to link the port with the fiber-optic network. For more information about SFPs and XFPs, refer “Hardware Specifications” chapter in the *Cisco ONS 15454 DWDM Reference Manual*, or the *Installing GBIC, SFP and XFP Optics Modules in Cisco ONS 15454, 15454 SDH, 15327, 15600, and 15310-CL Platforms* document available in the ONS 15454 production documentation website on www.cisco.com.



Note

You must modify 15 Min and 1 Day independently. To do so, choose the appropriate radio button and click **Refresh**.



Note

Do not modify the Laser Bias parameters.

Table 5-41 MXP_2.5G_10G, MXP_2.5G_10E, MXP_2.5G_10E_C, or MXP_2.5G_10E_L Card Client Interfaces TCA Thresholds

Port Type (by CTC)	Pluggable Port Module (SFP)	TCA RX Power High	TCA RX Power Low	TCA TX Power High	TCA TX Power Low
OC-48	ONS-SE-2G-S1	-3	-18	3	-16
	15454-SFP-OC48-IR	0	-18	6	-11

Table 5-41 *MXP_2.5G_10G, MXP_2.5G_10E, MXP_2.5G_10E_C, or MXP_2.5G_10E_L Card Client Interfaces TCA Thresholds (continued)*

Port Type (by CTC)	Pluggable Port Module (SFP)	TCA RX Power High	TCA RX Power Low	TCA TX Power High	TCA TX Power Low
STM-16	ONS-SE-2G-S1	-3	-18	3	-16
	15454E-SFP-L.16.1	0	-18	6	-11

- Step 4** Repeat [Step 3](#) to provision each additional client port.
- Step 5** Under Types, click the **Alarm** radio button and click **Refresh**.
- Step 6** Referring to [Table 5-42](#), provision the client Port *N* (where *N* = 1 through 4) Alarm thresholds for RX Power High, RX Power Low, TX Power High, and TX Power Low based on the client interface that is provisioned.



Note You must modify 15 Min and 1 Day independently. To do so, choose the appropriate radio button and click **Refresh**.



Note Do not modify the Laser Bias parameters.

Table 5-42 *MXP_2.5G_10G, MXP_2.5G_10E, MXP_2.5G_10E_C, or MXP_2.5G_10E_L Card Client Interfaces Alarm Thresholds*

Port Type (by CTC)	Pluggable Port Module (SFP)	Alarm RX Power High	Alarm RX Power Low	Alarm TX Power High	Alarm TX Power Low
OC-48	ONS-SE-2G-S1	0	-21	0	-13
	15454-SFP-OC48-IR	3	-21	3	-8
STM-16	ONS-SE-2G-S1	0	-21	0	-13
	15454E-SFP-L.16.1	3	-21	3	-8

- Step 7** Click **Apply**.
- Step 8** Repeat Steps [6](#) and [7](#) to provision each additional client port. When you have finished provisioning client ports, continue with [Step 9](#).
- Step 9** Return to your originating procedure (NTP).

DLP-G228 Change the 4x2.5G Muxponder Line OTN Settings

Purpose	This task changes the line OTN settings for MXP_2.5G_10G, MXP_2.5G_10E, MXP_2.5G_10E_C, and MXP_2.5G_10E_L muxponder cards.
Tools/Equipment	None
Prerequisite Procedures	DLP-G46 Log into CTC, page 2-25
Required/As Needed	As needed
Onsite/Remote	Onsite or remote
Security Level	Provisioning or higher

- Step 1** In node view (single-shelf mode) or shelf view (multishelf view), double-click the MXP_2.5G_10G, MXP_2.5G_10E, MXP_2.5G_10E_C, or MXP_2.5G_10E_L card where you want to change the line OTN settings.
- Step 2** Click the **Provisioning > OTN** tabs, then choose one of the following subtabs: **OTN Lines**, **OTN G.709 Thresholds**, **FEC Thresholds**, or **Trail Trace Identifier**.
- Step 3** Modify any of the settings described in Tables [5-43](#) through [5-46](#).



Note You must modify Near End and Far End independently; 15 Min and 1 Day independently; and SM and PM independently. To do so, choose the appropriate radio button and click **Refresh**.

[Table 5-43](#) describes the values on the Provisioning > OTN > OTN Lines tab.



Note In [Table 5-43](#), some parameter tabs or values do not always apply to all MXP_2.5G_10G, MXP_2.5G_10E, MXP_2.5G_10E_C, or MXP_2.5G_10E_L cards. If the tabs or values do not apply, they do not appear in CTC.

Table 5-43 *MXP_2.5G_10G, MXP_2.5G_10E, MXP_2.5G_10E_C, or MXP_2.5G_10E_L Card Line OTN Settings*

Parameter	Description	Options
Port	(Display only) Displays the port number.	5 (Trunk)
G.709 OTN	Sets the OTN lines according to ITU-T G.709.	<ul style="list-style-type: none"> • Enable • Disable
FEC	Sets the OTN line FEC mode. FEC mode can be Disabled or Enabled. With the MXP_2.5G_10E card, Enhanced FEC (E-FEC) mode can be enabled to provide greater range and lower bit error rate. E-FEC applies only to the MXP_2.5G_10E card.	<ul style="list-style-type: none"> • Enable—(MXP_2.5G_10G only) FEC is on. • Disable—FEC is off. • Standard—(MXP_2.5G_10E only) FEC is on. • Enhanced—(MXP_2.5G_10E only) Enhanced FEC is on.

Table 5-43 *MXP_2.5G_10G, MXP_2.5G_10E, MXP_2.5G_10E_C, or MXP_2.5G_10E_L Card Line OTN Settings (continued)*

Parameter	Description	Options
SD BER	Sets the signal degrade bit error rate.	<ul style="list-style-type: none"> • 1E-5 • 1E-6 • 1E-7 • 1E-8 • 1E-9
SF BER	(Display only) Sets the signal fail bit error rate.	<ul style="list-style-type: none"> • 1E-5
Asynch/Synch Mapping	(MXP_2.5G_10E only) The MXP_2.5G_10E can perform standard ODU multiplexing according to ITU-T G.709. The card uses this to aggregate the four OC-48 client signals.	<ul style="list-style-type: none"> • ODU Multiplex

Table 5-44 describes the values on the Provisioning > OTN > OTN G.709 Thresholds tab.

Table 5-44 *MXP_2.5G_10G, MXP_2.5G_10E, MXP_2.5G_10E_C, or MXP_2.5G_10E_L ITU-T G.709 Threshold Settings*

Parameter	Description	Options
Port	(Display only) Port number	5 (Trunk)
ES	Errored seconds	<p>Numeric. Threshold display options include:</p> <ul style="list-style-type: none"> • Direction—Near End or Far End • Interval—15 Min (minutes) or 1 day • Types—SM (OTUk) or PM (ODUk) <p>Choose an option in each category and click Refresh.</p> <p>Note SM (OTUk) is the ITU-T G.709 optical channel transport unit order of k overhead frame used for management and performance monitoring. PM (ODUk) is the ITU-T G.709 optical channel data unit order of k overhead frame unit used for path performance monitoring.</p>

Table 5-44 *MXP_2.5G_10G, MXP_2.5G_10E, MXP_2.5G_10E_C, or MXP_2.5G_10E_L ITU-T G.709 Threshold Settings (continued)*

Parameter	Description	Options
SES	Severely errored seconds. Two types of thresholds can be asserted. Selecting the SM (OTUk) radio button selects FEC, overhead management, and PM using OTUk. Selecting the PM radio button selects path PM using ODUk.	Numeric. Threshold display options include: <ul style="list-style-type: none"> • Direction—Near End or Far End • Interval—15 Min (minutes) or 1 day • Types—SM (OTUk) or PM (ODUk) Choose an option in each category and click Refresh .
UAS	Unavailable seconds	Numeric. Threshold display options include: <ul style="list-style-type: none"> • Direction—Near End or Far End • Interval—15 Min (minutes) or 1 day • Types—SM (OTUk) or PM (ODUk) Choose an option in each category and click Refresh .
BBE	Background block errors	Numeric. Threshold display options include: <ul style="list-style-type: none"> • Direction—Near End or Far End • Interval—15 Min (minutes) or 1 day • Types—SM (OTUk) or PM (ODUk) Choose an option in each category and click Refresh .
FC	Failure counter	Numeric. Threshold display options include: <ul style="list-style-type: none"> • Direction—Near End or Far End • Interval—15 Min (minutes) or 1 day • Types—SM (OTUk) or PM (ODUk) Choose an option in each category and click Refresh .

Table 5-45 describes the values on the Provisioning > OTN > FEC Thresholds tab.

Table 5-45 *MXP_2.5G_10G, MXP_2.5G_10E, MXP_2.5G_10E_C, or MXP_2.5G_10E_L FEC Threshold Settings*

Parameter	Description	Options
Port	(Display only) Displays the port number.	5 (Trunk)

Table 5-45 *MXP_2.5G_10G, MXP_2.5G_10E, MXP_2.5G_10E_C, or MXP_2.5G_10E_L FEC Threshold Settings (continued)*

Parameter	Description	Options
Bit Errors Corrected	Displays the number of bit errors corrected during the interval selected. The interval can be set for 15 minutes or one day.	Numeric
Uncorrectable Words	Displays the number of uncorrectable words during the interval selected. The interval can be set for 15 minutes or one day.	Numeric

Table 5-46 describes the values on the Provisioning > OTN > Trail Trace Identifier tab.

Table 5-46 *MXP_2.5G_10G, MXP_2.5G_10E, MXP_2.5G_10E_C, or MXP_2.5G_10E_L Trail Trace Identifier Settings*

Parameter	Description	Options
Port	Sets the port number. The trail trace identifier is applicable only to the trunk interface, which handles ITU-T G.709 frames.	5 (Trunk)
Level	Sets the level.	<ul style="list-style-type: none"> Section Path
Received Trace Mode	Sets the trace mode.	<ul style="list-style-type: none"> Off/None Manual
Disable FDI on TTIM	If a Trace Identifier Mismatch on Section overhead alarm arises because of a J0 overhead string mismatch, no Forward Defect Indication (FDI) signal is sent to the downstream nodes if this box is checked.	<ul style="list-style-type: none"> Checked (FDI on TTIM is disabled) Unchecked (FDI on TTIM is not disabled)
Transmit	Displays the current transmit string; sets a new transmit string. You can click the button on the right to change the display. Its title changes, based on the current display mode. Click Hex to change the display to hexadecimal (button changes to ASCII); click ASCII to change the display to ASCII (button changes to Hex).	String of trace string size; trail trace identifier is 64 bytes in length.
Expected	Displays the current expected string; sets a new expected string. You can click the button on the right to change the display. Its title changes, based on the current display mode. Click Hex to change the display to hexadecimal (button changes to ASCII); click ASCII to change the display to ASCII (button changes to Hex).	String of trace string size

Table 5-46 *MXP_2.5G_10G, MXP_2.5G_10E, MXP_2.5G_10E_C, or MXP_2.5G_10E_L Trail Trace Identifier Settings (continued)*

Parameter	Description	Options
Received	(Display only) Displays the current received string. You can click Refresh to manually refresh this display, or check the Auto-refresh every 5 sec box to keep this panel updated.	String of trace string size
Auto-refresh	If checked, automatically refreshes the display every 5 minutes.	Checked/unchecked (default)

Step 4 Click **Apply**.

Step 5 Return to your originating procedure (NTP).

NTP-G99 Modify the 2.5G Data Muxponder Card Line Settings and PM Parameter Thresholds

Purpose	This procedure changes the line and threshold settings for the MXP_MR_2.5G and MXPP_MR_2.5G muxponder cards.
Tools/Equipment	None
Prerequisite Procedures	<p>NTP-G32 Install the Transponder and Muxponder Cards, page 3-50</p> <p>DLP-G63 Install an SFP or XFP, page 3-52</p> <p>DLP-G277 Provision a Multirate PPM, page 5-6 (if necessary)</p> <p>DLP-G278 Provision the Optical Line Rate, page 5-9 (if necessary)</p>
Required/As Needed	As needed
Onsite/Remote	Onsite or remote
Security Level	Provisioning or higher

Step 1 Complete the “[DLP-G46 Log into CTC](#)” task on page 2-25 at the node where you want to change the muxponder card settings. If you are already logged in, proceed to [Step 2](#).

Step 2 As needed, complete the “[NTP-G103 Back Up the Database](#)” procedure on page 13-2 to preserve the existing transmission settings.

Step 3 Perform any of the following tasks as needed:

- [DLP-G236 Change the 2.5G Data Muxponder Client Line Settings, page 5-80](#)
- [DLP-G237 Change the 2.5G Data Muxponder Distance Extension Settings, page 5-83](#)
- [DLP-G238 Change the 2.5G Data Muxponder SONET \(OC-48\)/SDH \(STM-16\) Settings, page 5-85](#)
- [DLP-G239 Change the 2.5G Data Muxponder Section Trace Settings, page 5-87](#)
- [DLP-G240 Change the 2.5G Data Muxponder SONET or SDH Line Thresholds, page 5-90](#)

- [DLP-G321 Change the 2.5G Data Muxponder Line Thresholds for 1G Ethernet or 1G FC/FICON Payloads, page 5-92](#)
- [DLP-G307 Provision the 2.5G Data Muxponder Trunk Port Alarm and TCA Thresholds, page 5-94](#)
- [DLP-G308 Provision the 2.5G Data Muxponder Client Port Alarm and TCA Thresholds, page 5-95](#)
- [DLP-G370 Change the 2.5G Data Muxponder Trunk Wavelength Settings, page 5-89](#)



Note To use the Alarm Profiles tab, including creating alarm profiles and suppressing alarms, see [Chapter 8, “Manage Alarms.”](#)

Stop. You have completed this procedure.

DLP-G236 Change the 2.5G Data Muxponder Client Line Settings

Purpose	This task changes the client line settings for MXP_MR_2.5G and MXPP_MR_2.5G muxponder cards.
Tools/Equipment	None
Prerequisite Procedures	DLP-G46 Log into CTC, page 2-25
Required/As Needed	As needed
Onsite/Remote	Onsite or remote
Security Level	Provisioning or higher

- Step 1** In node view (single-shelf mode) or shelf view (multishelf view), double-click the MXP_MR_2.5G or MXPP_MR_2.5G card where you want to change the line settings.
- Step 2** Click the **Provisioning > Line > Client** tabs. Tabs and parameter selections vary according to PPM provisioning.
- Step 3** Modify any of the settings for the Client tab as described in [Table 5-47](#).

Table 5-47 MXP_MR_2.5G or MXPP_MR_2.5G Card Client Settings

Parameter	Description	Options
Port	(Display only) Port number.	<ul style="list-style-type: none"> • 1 • 2
Port Name	The user can assign a logical name for each of the ports shown by filling in this field.	User-defined. Name can be up to 32 alphanumeric/ special characters. Blank by default. See the “DLP-G104 Assign a Name to a Port” task on page 7-3 .
Admin State	Sets the port service state unless network conditions prevent the change. For more information about administrative states, refer to the “Administrative and Service States” appendix in the <i>Cisco ONS 15454 DWDM Reference Manual</i> .	<ul style="list-style-type: none"> • IS (ANSI) or Unlocked (ETSI) • OOS,DSBLD (ANSI) or Locked,disabled (ETSI) • OOS,MT (ANSI) or Locked,maintenance (ETSI)

Table 5-47 MXP_MR_2.5G or MXPP_MR_2.5G Card Client Settings (continued)

Parameter	Description	Options
Service State	Identifies the autonomously generated state that gives the overall condition of the port. Service states appear in the format: Primary State-Primary State Qualifier, Secondary State. For more information about service states, refer to the “Administrative and Service States” appendix in the <i>Cisco ONS 15454 DWDM Reference Manual</i> .	<ul style="list-style-type: none"> IS-NR (ANSI) or Unlocked-enabled (ETSI) OOS-AU,AINS (ANSI) or Unlocked-disabled, automaticInService (ETSI) OOS-MA,DSBLD (ANSI) or Locked-enabled,disabled (ETSI) OOS-MA,MT (ANSI) or Locked-enabled,maintenance (ETSI)
ALS Mode	Sets the ALS function.	<ul style="list-style-type: none"> Disabled (default): ALS is off; the laser is not automatically shut down when traffic outages (LOS) occur. Auto Restart: (MXP_MR_2.5G only) ALS is on; the laser automatically shuts down when traffic outages (LOS) occur. It automatically restarts when the conditions that caused the outage are resolved. Manual Restart: ALS is on; the laser automatically shuts down when traffic outages (LOS) occur. However, the laser must be manually restarted when conditions that caused the outage are resolved. Manual Restart for Test: Manually restarts the laser for testing.

Table 5-47 MXP_MR_2.5G or MXPP_MR_2.5G Card Client Settings (continued)

Parameter	Description	Options
Reach	Displays the optical reach distance of the client port.	<p>The reach distances that appear in the drop-down list depend on the card:</p> <ul style="list-style-type: none"> • Autoprovision—The system to automatically provision the reach from the pluggable port module (PPM) reach value on the hardware. • SX—Short laser wavelength on multimode fiber optic cable for a maximum length of 550 meters. The operating wavelength range is 770-860 nm.) • LX—Long wavelength for a long haul fiber optic cable for a maximum length of 10 km. The operating wavelength range is 1270-1355 nm.) • CX—Two pairs of 150-ohm shielded twisted pair cable for a maximum length of 25 meters.) • T—Four pairs of Category 5 Unshielded Twisted Pair cable for a maximum length of 100 meters.) • DX—Single mode up to 40 km. The operating wavelength range is 1430-1580 nm.) • HX—Single mode up to 40 km. The operating wavelength range is 1280-1335 nm.) • ZX—Extended wavelength single-mode optical fiber for up to 100 km. The operating wavelength range is 1500-1580 nm.) • VX—Single mode up to 100 km. The operating wavelength range is 1500-1580 nm.)
Wavelength	Displays the wavelength of the client port.	<ul style="list-style-type: none"> • First Tunable Wavelength • Further wavelengths:850 nm through 1560.61 nm; 100-GHz ITU spacing; CWDM spacing

Step 4 Click **Apply**.

Step 5 Return to your originating procedure (NTP).

DLP-G237 Change the 2.5G Data Muxponder Distance Extension Settings

Purpose	This task changes the distance extension settings for MXP_MR_2.5G and MXPP_MR_2.5G muxponder cards. Distance extension should be enabled when the distance between the MXP_MR_2.5G/MXPP_MR_2.5G source and destination cards is greater than 5 km and/or when the Fibre Channel switch buffer is set to 128 bytes or less.
Tools/Equipment	None
Prerequisite Procedures	DLP-G46 Log into CTC, page 2-25
Required/As Needed	As needed
Onsite/Remote	Onsite or remote
Security Level	Provisioning or higher



Note Distance extension settings can be changed only if the facilities are out of service (OOS).



Note If distance extension is enabled for one MXP_MR_2.5G/MXPP_MR_2.5G card, it must be enabled on the MXP_MR_2.5G/MXPP_MR_2.5G card at the other end. A GFP-DE-MISMATCH alarm is raised if distance extension is enabled for a card at only one end.



Note The MXP_MR_2.5G/MXPP_MR_2.5G cards can operate with different Fibre Channel switch buffers at each end. However, the traffic flow will be unequal.



Note The distance extension parameters only apply to client ports (Ports 1 to 8) and not to the trunk ports (Port 9 for MXP_MR_2.5G card or Ports 9 and 10 for the MXPP_MR_2.5G card).

- Step 1** In node view (single-shelf mode) or shelf view (multishelf view), double-click the MXP_MR_2.5G or MXPP_MR_2.5G card where you want to change the distance extension settings.
- Step 2** Click the **Provisioning > Line > Service** tabs, where *Service* is the service type provisioned on the Pluggable Port Modules tab, such as SONET (ANSI), SDH (ETSI), 1G Ethernet, and others.
- Step 3** Locate the Trunk port table row and verify that the Service State column value is OOS-MA,DSBLD (ANSI) or Locked-enabled,disabled (ETSI). If yes, continue with [Step 4](#). If not, complete the following steps:
 - a. Click the **Admin State** table cell and choose **OOS,MT** (ANSI) or **Locked,Maintenance** (ETSI).
 - b. Click **Apply**, then **Yes**.
- Step 4** Click the **Provisioning > Line > Distance Extension** tabs. Tabs and parameter selections vary according to PPM provisioning.
- Step 5** Modify any of the settings for the Distance Extension tab as described in [Table 5-48](#).

Table 5-48 *MXP_MR_2.5G or MXPP_MR_2.5G Card Line Distance Extension Settings*

Parameter	Description	Options
Port	(Display only) Port number.	<ul style="list-style-type: none"> • 1 • 2
Enable Distance Extension	<p>If checked, allows end-to-end distances up to 1600 km for FC1G and up to 800 km for FC2G through a flow control scheme based on the transparent-mode Generic Framing Protocol (GFP-T). GFP-T flow control enables the node to be part of a storage area network (SAN) with long-distance remote nodes. Cisco recommends that you enable distance extension when one or both of the following conditions exist:</p> <ul style="list-style-type: none"> • The distance between the source and destination MXP_MR_2.5G/MXPP_MR_2.5G cards is greater than 5 km. • The FC switch buffer at either end is less than 128 bytes. <p>If distance extension is enabled, the Fibre Channel switch must be set to Interop or Open Fabric mode, depending on the switch. By default, the MXP_MR_2.5G/MXPP_MR_2.5G card interoperates with the Cisco Multilayer Director Switch (MDS) storage products.</p>	Checked or unchecked
Auto Detect Credits	(Available only when distance extension is enabled). If checked, enables the node to detect the transmit credits from a remote node. Credits are used for link flow control and for Extended Link Protocol (ELP) login frames between Fibre Channel/FICON switch E ports. If distance extension is enabled, Cisco recommends that you enable Auto Detect Credits.	Checked or unchecked
Credits Available	If Auto Detect Credits is not enabled, sets the number of credits when an ELP login frame setting is missing or if the ELP login frame cannot be detected.	Numeric. Values are 2 through 256 in multiples of 2.

Table 5-48 MXP_MR_2.5G or MXPP_MR_2.5G Card Line Distance Extension Settings (continued)

Parameter	Description	Options
Autoadjust GFP Buffer Threshold	If checked, the threshold of the GFP buffer between two MXP_MR_2.5G or two MXPP_MR_2.5G cards is automatically adjusted. This guarantees the best utilization of the SONET/SDH transport by balancing bandwidth and latency.	Checked or unchecked
GFP Buffers Available	If Autoadjust GFP Buffer Threshold is not checked, sets the GFP buffer depth. For shorter SONET transport distances, Cisco recommends lower values to decrease latency. For longer SONET transport distances, Cisco recommends higher values to provide higher bandwidth.	Numeric. Possible values are 16 through 1200 in multiples of 16.

- Step 6** Click **Apply**.
- Step 7** Return to your originating procedure (NTP).

DLP-G238 Change the 2.5G Data Muxponder SONET (OC-48)/SDH (STM-16) Settings

Purpose	This task changes the SONET (OC-48) or SDH (STM-16) settings for MXP_MR_2.5G and MXPP_MR_2.5G muxponder cards.
Tools/Equipment	None
Prerequisite Procedures	DLP-G46 Log into CTC, page 2-25
Required/As Needed	As needed
Onsite/Remote	Onsite or remote
Security Level	Provisioning or higher



Note SONET (OC-48)/SDH (STM-16) settings apply only to the trunk ports (Port 9 for the MXP_MR_2.5G card and Ports 9 and 10 for the MXPP_MR_2.5G card.)

- Step 1** In node view (single-shelf mode) or shelf view (multishelf view), double-click the MXP_MR_2.5G or MXPP_MR_2.5G card where you want to change the OC-48/STM-64 settings.
- Step 2** Click the **Provisioning > Line > SONET (ANSI)** or **SDH (ETSI)**. Tabs and parameter selections vary according to PPM provisioning.
- Step 3** Modify any of the settings for the SONET or SDH tab as described in [Table 5-49](#).

Table 5-49 MXP_MR_2.5G or MXPP_MR_2.5G Card Line SONET or SDH Settings

Parameter	Description	Options
Port	(Display only) Port number.	9 (trunk for MXP_MR_2.5G) or 9 and 10 (trunks for MXPP_MR_2.5G)
Port Name	Provides the ability to assign the specified port a name.	User-defined. Name can be up to 32 alphanumeric/special characters. Blank by default. See the “DLP-G104 Assign a Name to a Port” task on page 7-3.
Admin State	Sets the port service state unless network conditions prevent the change. For more information about administrative states, refer to the “Administrative and Service States” appendix in the <i>Cisco ONS 15454 DWDM Reference Manual</i> .	<ul style="list-style-type: none"> IS (ANSI) or Unlocked (ETSI) IS,AINS (ANSI) or Unlocked,automaticInService (ETSI) OOS,DSBLD (ANSI) or Locked,disabled (ETSI) OOS,MT (ANSI) or Locked,maintenance (ETSI)
Service State	(Display only) Identifies the autonomously generated state that gives the overall condition of the port. Service states appear in the format: Primary State-Primary State Qualifier, Secondary State. For more information about service states, refer to the “Administrative and Service States” appendix in the <i>Cisco ONS 15454 DWDM Reference Manual</i> .	<ul style="list-style-type: none"> IS-NR (ANSI) or Unlocked-enabled (ETSI) OOS-AU,AINS (ANSI) or Unlocked-disabled, automaticInService (ETSI) OOS-MA,DSBLD (ANSI) or Locked-enabled,disabled (ETSI) OOS-MA,MT (ANSI) or Locked-enabled,maintenance (ETSI)
SF BER ¹	Sets the signal fail bit error rate.	<ul style="list-style-type: none"> 1E-3 1E-4 1E-5
SD BER ¹	Sets the signal degrade bit error rate.	<ul style="list-style-type: none"> 1E-5 1E-6 1E-7 1E-8 1E-9
ALS Mode	Sets the ALS function mode. The DWDM transmitter supports ALS according to ITU-T G.644 (06/99). ALS can be disabled or can be set for one of three mode options.	<ul style="list-style-type: none"> Disable (default): ALS is off; the laser is not automatically shut down when traffic outages (LOS) occur. Auto Restart: ALS is on; the laser automatically shuts down when traffic outages (LOS) occur. It automatically restarts when the conditions that caused the outage are resolved. Manual Restart: ALS is on; the laser automatically shuts down when traffic outages (LOS) occur. However, the laser must be manually restarted when conditions that caused the outage are resolved. Manual Restart for Test: Manually restarts the laser for testing.

Table 5-49 *MXP_MR_2.5G or MXPP_MR_2.5G Card Line SONET or SDH Settings (continued)*

Parameter	Description	Options
AINS Soak	Sets the automatic in-service soak period. Double-click the time and use the up and down arrows to change settings.	<ul style="list-style-type: none"> Duration of valid input signal, in hh.mm format, after which the card becomes in service (IS) automatically 0 to 48 hours, 15-minute increments
Type	The optical transport type.	<ul style="list-style-type: none"> SONET (ANSI) SDH (ETSI)
SyncMsgIn	Sets the EnableSync card parameter. Enables synchronization status messages (S1 byte), which allow the node to choose the best timing source.	Checked or unchecked
Send DoNotUse	Sets the Send DoNotUse card state. When checked, sends a DUS message on the S1 byte.	Checked or unchecked
ProvidesSync	Sets the ProvidesSync card parameter. If checked, the card is provisioned as an NE timing reference.	Checked or unchecked

1. SF BER and SD BER thresholds apply only to trunk ports (Port 9 for MXP_MR_2.5G and Ports 9 and 10 for MXPP_MR_2.5G).

Step 4 Click **Apply**.

Step 5 Return to your originating procedure (NTP).

DLP-G239 Change the 2.5G Data Muxponder Section Trace Settings

Purpose	This task changes the section trace settings for MXP_MR_2.5G and MXPP_MR_2.5G muxponder cards.
Tools/Equipment	None
Prerequisite Procedures	DLP-G46 Log into CTC, page 2-25
Required/As Needed	As needed
Onsite/Remote	Onsite or remote
Security Level	Provisioning or higher

Step 1 In node view (single-shelf mode) or shelf view (multishelf view), double-click the MXP_MR_2.5G or MXPP_MR_2.5G card where you want to change the section trace settings.

Step 2 Click the **Provisioning > Line > Section Trace** tabs. Tabs and parameter selections vary according to PPM provisioning.

Step 3 Modify any of the settings in the Section Trace tab as described in [Table 5-50](#).

Table 5-50 *MXP_MR_2.5G or MXPP_MR_2.5G Card Line Section Trace Settings*

Parameter	Description	Options
Port	(Display only) Port number.	<ul style="list-style-type: none"> 9 (trunk port for MXP_MR_2.5G) 9 and 10 (trunk ports for MXPP_MR_2.5G)
Received Trace Mode	Sets the received trace mode.	<ul style="list-style-type: none"> Off/None Manual
Disable AIS/RDI on TIM-S	If an TIM on Section overhead alarm arises because of a J0 overhead string mismatch, no alarm indication signal is sent to downstream nodes if this box is checked.	<ul style="list-style-type: none"> Checked (AIS/RDI on TIM-S is disabled) Unchecked (AIS/RDI on TIM-S is not disabled)
Transmit Section Trace String Size	Sets the trace string size.	<ul style="list-style-type: none"> 1 byte 16 byte
Transmit	Displays the current transmit string; sets a new transmit string. You can click the button on the right to change the display. Its title changes, based on the current display mode. Click Hex to change the display to hexadecimal (button changes to ASCII); click ASCII to change the display to ASCII (button changes to Hex).	String of trace string size
Expected	Displays the current expected string; sets a new expected string. You can click the button on the right to change the display. Its title changes, based on the current display mode. Click Hex to change the display to hexadecimal (button changes to ASCII); click ASCII to change the display to ASCII (button changes to Hex).	String of trace string size
Received	(Display only) Displays the current received string. You can click Refresh to manually refresh this display, or check the Auto-refresh every 5 sec check box to keep this panel updated.	String of trace string size
Auto-refresh	If checked, automatically refreshes the display every 5 seconds.	Checked/unchecked (default)

Step 4 Click **Apply**.

Step 5 Return to your originating procedure (NTP).

DLP-G370 Change the 2.5G Data Muxponder Trunk Wavelength Settings

Purpose	This task changes the trunk wavelength settings for the MXP_MR_2.5G and MXPP_MR_2.5G.
Tools/Equipment	None
Prerequisite Procedures	DLP-G46 Log into CTC, page 2-25
Required/As Needed	As needed
Onsite/Remote	Onsite or remote
Security Level	Provisioning or higher

- Step 1** In node view (single-shelf mode) or shelf view (multishelf view), double-click the MXP_MR_2.5G or MXPP_MR_2.5G card where you want to change the trunk wavelength settings.
- Step 2** Click the **Provisioning > Line > Wavelength Trunk Settings** tabs.
- Step 3** Modify any of the settings for the Wavelength Trunk Settings tab as described in [Table 5-51](#).

Table 5-51 MXP_MR_2.5G or MXPP_MR_2.5G Card Wavelength Trunk Settings

Parameter	Description	Options
Port	(Display only) Displays the port number.	9 (Trunk) 10 (Trunk) (MXPP_MR_2.5G only)
Band	Indicates the wavelength band that can be provisioned. For MXP_MR_2.5G and MXPP_MR_2.5G cards, the field is display-only.	C—Only the C band is available
Even/Odd	Sets the wavelengths available for provisioning. This field does not apply to MXP_MR_2.5G or MXPP_MR_2.5G cards	—
Wavelength	The wavelength provisioned for the trunk.	<ul style="list-style-type: none"> First Tunable Wavelength Further wavelengths in 100-GHz ITU-T, C-band spacing. If the card is installed, the wavelengths it carries are identified with two asterisks. Other wavelengths have a dark grey background. If the card is not installed, all wavelengths appear with a dark grey background.

- Step 4** Click **Apply**.
- Step 5** Return to your originating procedure (NTP).

DLP-G240 Change the 2.5G Data Muxponder SONET or SDH Line Thresholds

Purpose	This task changes the SONET or SDH line threshold settings for MXP_MR_2.5G and MXPP_MR_2.5G muxponder cards.
Tools/Equipment	None
Prerequisite Procedures	DLP-G46 Log into CTC, page 2-25
Required/As Needed	As needed
Onsite/Remote	Onsite or remote
Security Level	Provisioning or higher

- Step 1** In node view (single-shelf mode) or shelf view (multishelf view), double-click the MXP_MR_2.5G or MXPP_MR_2.5G card where you want to change the line threshold settings.
- Step 2** Click the **Provisioning > Line Thresholds > SONET Thresholds (ANSI)** or **SDH Thresholds (ETSI)** tabs.
- Step 3** Modify any of the settings as shown in [Table 5-52](#).



Note You must modify Near End and Far End independently; 15 Min and 1 Day independently; and Line and Section independently. To do so, choose the appropriate radio button and click **Refresh**.



Note In [Table 5-52](#), some parameters or options do not apply to all MXP_MR_2.5G or MXPP_MR_2.5G cards. If the parameters or options do not apply, they do not appear in CTC.

Table 5-52 MXP_MR_2.5G or MXPP_MR_2.5G Card Line Threshold Settings

Field	Description	ONS 15454 Options	ONS 15454 SDH Options
Port	(Display only) Port number	<ul style="list-style-type: none"> 9 (MXP_MR_2.5G) 9 and 10 (MXPP_MR_2.5G) 	<ul style="list-style-type: none"> 9 (MXP_MR_2.5G) 9 and 10 (MXPP_MR_2.5G)
EB	Path Errored Block indicates that one or more bits are in error within a block	Numeric. Threshold display options include: <ul style="list-style-type: none"> Direction—Near End or Far End Interval—15 Min (minutes) or 1 day Types—Line or Section (near end only) Choose an option in each category and click Refresh .	Numeric. Threshold display options include: <ul style="list-style-type: none"> Direction—Near End or Far End Interval—15 Min (minutes) or 1 day Types—Multiplex Section or Regeneration Section (near end only) Choose an option in each category and click Refresh .
CV	Coding violations	Numeric. Threshold display options include: <ul style="list-style-type: none"> Direction—Near End or Far End Interval—15 Min (minutes) or 1 day Types—Line or Section (near end only) Choose an option in each category and click Refresh .	Numeric. Threshold display options include: <ul style="list-style-type: none"> Direction—Near End or Far End Interval—15 Min (minutes) or 1 day Types—Multiplex Section or Regeneration Section (near end only) Choose an option in each category and click Refresh .

Table 5-52 MXP_MR_2.5G or MXPP_MR_2.5G Card Line Threshold Settings (continued)

Field	Description	ONS 15454 Options	ONS 15454 SDH Options
ES	Errored seconds	Numeric. Threshold display options include: <ul style="list-style-type: none"> • Direction—Near End or Far End • Interval—15 Min (minutes) or 1 day • Types—Line or Section (near end only) Choose an option in each category and click Refresh .	Numeric. Threshold display options include: <ul style="list-style-type: none"> • Direction—Near End or Far End • Interval—15 Min (minutes) or 1 day • Types—Multiplex Section or Regeneration Section (near end only) Choose an option in each category and click Refresh .
SES	Severely errored seconds	Numeric. Threshold display options include: <ul style="list-style-type: none"> • Direction—Near End or Far End • Interval—15 Min (minutes) or 1 day • Types—Line or Section (near end only) Choose an option in each category and click Refresh .	Numeric. Threshold display options include: <ul style="list-style-type: none"> • Direction—Near End or Far End • Interval—15 Min (minutes) or 1 day • Types—Multiplex Section or Regeneration Section (near end only) Choose an option in each category and click Refresh .
BBE	Background block errors	Numeric. Threshold display options include: <ul style="list-style-type: none"> • Direction—Near End or Far End • Interval—15 Min (minutes) or 1 day • Types—SM (OTUk) or PM (ODUk) Choose an option in each category and click Refresh .	Numeric. Threshold display options include: <ul style="list-style-type: none"> • Direction—Near End or Far End • Interval—15 Min (minutes) or 1 day • Types—SM (OTUk) or PM (ODUk) Choose an option in each category and click Refresh .
SEFS	(Section or Regeneration Section only) Severely errored framing seconds	Numeric. Threshold display options include: <ul style="list-style-type: none"> • Direction—Near End or Far End • Interval—15 Min (minutes) or 1 day • Types—Section only Choose an option in each category and click Refresh .	Numeric. Threshold display options include: <ul style="list-style-type: none"> • Direction—Near End or Far End • Interval—15 Min (minutes) or 1 day • Types—Regeneration Section (only) Choose an option in each category and click Refresh .
FC	(Line or Multiplex Section only) Failure count	Numeric. Threshold display options include: <ul style="list-style-type: none"> • Direction—Near End or Far End • Interval—15 Min (minutes) or 1 day • Types—Section only Choose an option in each category and click Refresh .	Numeric. Threshold display options include: <ul style="list-style-type: none"> • Direction—Near End or Far End • Interval—15 Min (minutes) or 1 day • Types—Regeneration Section (only) Choose an option in each category and click Refresh .
UAS	(Line or Multiplex Section only) Unavailable seconds	Numeric. Threshold display options include: <ul style="list-style-type: none"> • Direction—Near End or Far End • Interval—15 Min (minutes) or 1 day • Types—Section only Choose an option in each category and click Refresh .	Numeric. Threshold display options include: <ul style="list-style-type: none"> • Direction—Near End or Far End • Interval—15 Min (minutes) or 1 day • Types—Regeneration Section (only) Choose an option in each category and click Refresh .

- Step 4** Click **Apply**.
- Step 5** Return to your originating procedure (NTP).

DLP-G321 Change the 2.5G Data Muxponder Line Thresholds for 1G Ethernet or 1G FC/FICON Payloads

Purpose	This task changes the line threshold settings for MXP_MR_10G and MXPP_MR_2.5G transponder cards carrying the 1G Ethernet or 1G FC/FICON payloads.
Tools/Equipment	None
Prerequisite Procedures	DLP-G46 Log into CTC, page 2-25
Required/As Needed	As needed
Onsite/Remote	Onsite or remote
Security Level	Provisioning or higher

- Step 1** Display the MXP_MR_2.5G or MXPP_MR_2.5G card where you want to change the line threshold settings in card view.
- Step 2** Click the **Provisioning > Line Thresholds > RMON Thresholds** tabs.
- Step 3** Click **Create**. The Create Threshold dialog box appears.
- Step 4** From the Port drop-down list, choose the applicable port.
- Step 5** From the Variable drop-down list, choose an Ethernet variable. See [Table 5-53](#) for a list of available Ethernet variables.

Table 5-53 MXP_MR_2.5G and MXPP_MR_2.5G Card 1G Ethernet or 1G FC/FICON Variables

Variable	Description
ifInOctets	Number of bytes received since the last counter reset.
rxTotalPkts	Total number of receive packets.
ifInDiscards	Number of inbound packets that were chosen to be discarded even though no errors had been detected to prevent their being deliverable to a higher-layer protocol.
ifInErrors	Total number of receive errors.
ifOutOctets	The total number of octets transmitted out of the interface, including framing characters.
txTotalPkts	Total number of transmitted packets.
ifOutDiscards	Number of outbound packets that were chosen to be discarded even though no errors had been detected to prevent their being transmitted.
mediaIndStatsRxFramesTruncated	Total number of frames received that are less than 5 bytes. This value is a part of high-level data link control (HDLC) and GFP port statistics.

Table 5-53 MXP_MR_2.5G and MXPP_MR 2.5G Card 1G Ethernet or 1G FC/FICON Variables

mediaIndStatsRxFramesTooLong	Number of received frames that exceed the maximum transmission unit (MTU). This value is part of HDLC and GFP port statistics.
mediaIndStatsRxFramesBadCRC	Number of receive data frames with payload cyclic redundancy check (CRC) errors when HDLC framing is used.
mediaIndStatsTxFramesBadCRC	Number of transmitted data frames with payload CRC errors when HDLC framing is used.
fcStatsLinkRecoveries	Number of link recoveries.
fcStatsZeroTxCredits	Number of transmit attempts that failed because of unavailable credits.
8b10bInvalidOrderedSets	Number of 8b10b disparity violations on the Fibre Channel line side.
8b10bStatsEncodingDispErrors	Number of 8b10b disparity violations on the Fibre Channel line side.

- Step 6** From the Alarm Type drop-down list, indicate whether the event will be triggered by the rising threshold, the falling threshold, or both the rising and falling thresholds.
- Step 7** From the Sample Type drop-down list, choose either **Relative** or **Absolute**. Relative restricts the threshold to use the number of occurrences in the user-set sample period. Absolute sets the threshold to use the total number of occurrences, regardless of time period.
- Step 8** Type in an appropriate number of seconds for the Sample Period.
- Step 9** Type in the appropriate number of occurrences for the Rising Threshold.

For a rising type of alarm, the measured value must move from below the falling threshold to above the rising threshold. For example, if a network is running below a rising threshold of 1000 collisions every 15 seconds and a problem causes 1001 collisions in 15 seconds, the excess occurrences trigger an alarm.

- Step 10** Enter the appropriate number of occurrences in the Falling Threshold field. In most cases a falling threshold is set lower than the rising threshold.

A falling threshold is the counterpart to a rising threshold. When the number of occurrences is above the rising threshold and then drops below a falling threshold, it resets the rising threshold. For example, when the network problem that caused 1001 collisions in 15 seconds subsides and creates only 799 collisions in 15 seconds, occurrences fall below a falling threshold of 800 collisions. This resets the rising threshold so that if network collisions again spike over a 1000 per 15-second period, an event again triggers when the rising threshold is crossed. An event is triggered only the first time a rising threshold is exceeded (otherwise, a single network problem might cause a rising threshold to be exceeded multiple times and cause a flood of events).

- Step 11** Click **OK**.
- Step 12** Return to your originating procedure (NTP).

DLP-G307 Provision the 2.5G Data Muxponder Trunk Port Alarm and TCA Thresholds

Purpose	This task changes the MXP_MR_2.5G and MXPP_MR_2.5G trunk port alarm and TCA thresholds.
Tools/Equipment	None
Prerequisite Procedures	DLP-G46 Log into CTC, page 2-25
Required/As Needed	As needed
Onsite/Remote	Onsite or remote
Security Level	Provisioning or higher



Note Throughout this task, trunk port refers to Port 9 (MXP_MR_2.5G and MXPP_MR_2.5G) and Port 10 (MXPP_MR_2.5G only).

Step 1 In node view (single-shelf mode) or shelf view (multishelf view), double-click the MXP_MR_2.5G or MXPP_MR_2.5G card where you want to change the trunk port alarm and TCA settings.

Step 2 Click the **Provisioning > Optics Thresholds** tabs.



Note You must modify 15 Min and 1 Day independently. To do so, choose the appropriate radio button and click **Refresh**.

Step 3 Provision the trunk port TCA thresholds for RX Power High to -9 dBm and for RX Power Low to -23 dBm.

Step 4 Under Types, click the **Alarm** radio button and click **Refresh**.



Note Do not modify the Laser Bias parameters.

Step 5 Provision the trunk port Alarm thresholds for RX Power High to -7 dBm and for RX Power Low to -26 dBm.



Note You must modify 15 Min and 1 Day independently. To do so, choose the appropriate radio button and click **Refresh**.

Step 6 Click **Apply**.

Step 7 Return to your originating procedure (NTP).

DLP-G308 Provision the 2.5G Data Muxponder Client Port Alarm and TCA Thresholds

Purpose	This task provisions the client port alarm and TCA thresholds for the MXP_MR_2.5G and MXPP_MR_2.5G cards.
Tools/Equipment	None
Prerequisite Procedures	DLP-G278 Provision the Optical Line Rate, page 5-9 DLP-G46 Log into CTC, page 2-25
Required/As Needed	Required
Onsite/Remote	Onsite or remote
Security Level	Provisioning or higher

- Step 1** In node view (single-shelf mode) or shelf view (multishelf view), double-click the MXP_MR_2.5G or MXPP_MR_2.5G card where you want to change the client port alarm and TCA settings.
- Step 2** Click the **Provisioning > Optics Thresholds** tabs. The TCA thresholds are shown by default.
- Step 3** Referring to [Table 5-54](#), provision the client port (Ports 1 through 8) TCA thresholds for RX Power High, RX Power Low, TX Power High, and TX Power Low based on the client interface at the other end. For additional information about client SFP and XFP interfaces, also known as PPMs, refer to the “Hardware Specifications” appendix in the *Cisco ONS 15454 DWDM Reference Manual*.



Note Do not modify the Laser Bias parameters.



Note You must modify 15 Min and 1 Day independently. To do so, choose the appropriate radio button and click **Refresh**.

Table 5-54 MXP_MR_2.5G and MXPP_MR_2.5G Card Client Interface TCA Thresholds

Port Type (by CTC)	Pluggable Port Module (XFP)	TCA RX Power Low	TCA RX Power High	TCA TX Power Low	TCA TX Power High
FC1G	15454-SFP-GEFC-SX 15454E-SFP-GEFC-S ONS-SE-G2F-SX	-17	0	-16	3
	15454-SFP-GE+-LX 15454E-SFP-GE+-LX ONS-SE-G2F-LX	-20	-3	-16	3
FC2G	15454-SFP-GEFC-SX 15454E-SFP-GEFC-S ONS-SE-G2F-SX	-15	0	-16	3
	15454-SFP-GE+-LX 15454E-SFP-GE+-LX ONS-SE-G2F-LX	-20	-3	-16	3

Table 5-54 MXP_MR_2.5G and MXPP_MR_2.5G Card Client Interface TCA Thresholds (continued)

Port Type (by CTC)	Pluggable Port Module (XFP)	TCA RX Power Low	TCA RX Power High	TCA TX Power Low	TCA TX Power High
FICON1G	15454-SFP-GEFC-SX 15454E-SFP-GEFC-S ONS-SE-G2F-SX	-17	0	-16	3
	15454-SFP-GE+-LX 15454E-SFP-GE+-LX ONS-SE-G2F-LX	-20	-3	-16	3
FICON2G	15454-SFP-GEFC-SX 15454E-SFP-GEFC-S ONS-SE-G2F-SX	-17	0	-16	3
	15454-SFP-GE+-LX 15454E-SFP-GE+-LX ONS-SE-G2F-LX	-20	-3	-16	3
ONE_GE	15454-SFP-GEFC-SX 15454E-SFP-GEFC-S ONS-SE-G2F-SX	-17	0	-16	3
	15454-SFP-GE+-LX 15454E-SFP-GE+-LX ONS-SE-G2F-LX	-20	-3	-16	3
ESCON	ONS-SE-200-MM	-21	-14	-32	-11

Step 4 Click **Apply**.

Step 5 Repeat Steps 3 and 4 to provision each additional client port.

Step 6 Under Types, click the **Alarm** radio button and click **Refresh**.

Step 7 Referring to Table 5-55, provision the client port (Ports 1 through 8) Alarm thresholds for RX Power High, RX Power Low, TX Power High, and TX Power Low based on the client interface that is provisioned.



Note You must modify 15 Min and 1 Day independently. To do so, choose the appropriate radio button and click **Refresh**.

Table 5-55 MXP_MR_2.5G and MXPP_MR_2.5G Card Client Interface Alarm Thresholds

Port Type (by CTC)	Pluggable Port Module (XFP)	Alarm RX Power Low	Alarm RX Power High	Alarm TX Power Low	Alarm TX Power High
FC1G	15454-SFP-GEFC-SX 15454E-SFP-GEFC-S ONS-SE-G2F-SX	-20	3	-13	-1
	15454-SFP-GE+-LX 15454E-SFP-GE+-LX ONS-SE-G2F-LX	-23	0	-13	0

Table 5-55 MXP_MR_2.5G and MXPP_MR_2.5G Card Client Interface Alarm Thresholds

Port Type (by CTC)	Pluggable Port Module (XFP)	Alarm RX Power Low	Alarm RX Power High	Alarm TX Power Low	Alarm TX Power High
FC2G	15454-SFP-GEFC-SX 15454E-SFP-GEFC-S ONS-SE-G2F-SX	-18	3	-13	-1
	15454-SFP-GE+-LX 15454E-SFP-GE+-LX ONS-SE-G2F-LX	-23	0	-13	0
FICON1G	15454-SFP-GEFC-SX 15454E-SFP-GEFC-S ONS-SE-G2F-SX	-20	3	-13	-1
	15454-SFP-GE+-LX 15454E-SFP-GE+-LX ONS-SE-G2F-LX	-23	0	-13	0
FICON2G	15454-SFP-GEFC-SX 15454E-SFP-GEFC-S ONS-SE-G2F-SX	-20	3	-13	-1
	15454-SFP-GE+-LX 15454E-SFP-GE+-LX ONS-SE-G2F-LX	-23	0	-13	0
ONE_GE	15454-SFP-GEFC-SX 15454E-SFP-GEFC-S ONS-SE-G2F-SX	-20	3	-13	-1
	15454-SFP-GE+-LX 15454E-SFP-GE+-LX ONS-SE-G2F-LX	-23	0	-13	0
ESCON	ONS-SE-200-MM	-24	-11	-35	-8

Step 8 Click **Apply**.

Step 9 Repeat Steps 7 and 8 to provision each additional client port. When you have finished provisioning client ports, continue with [Step 10](#).

Step 10 Return to your originating procedure (NTP).

NTP-G148 Modify the 10G Data Muxponder Card Line Settings and PM Parameter Thresholds

Purpose	This procedure changes the line and threshold settings for the MXP_MR_10DME_C and MXP_MR_10DME_L muxponder cards.
Tools/Equipment	None

Prerequisite Procedures	NTP-G32 Install the Transponder and Muxponder Cards, page 3-50 DLP-G63 Install an SFP or XFP, page 3-52 DLP-G277 Provision a Multirate PPM, page 5-6 (if necessary) DLP-G278 Provision the Optical Line Rate, page 5-9 (if necessary)
Required/As Needed	As needed
Onsite/Remote	Onsite or remote
Security Level	Provisioning or higher

-
- Step 1** Complete the “[DLP-G46 Log into CTC](#)” task on page 2-25 at the node where you want to change the muxponder card settings. If you are already logged in, proceed to [Step 2](#).
- Step 2** As needed, complete the “[NTP-G103 Back Up the Database](#)” procedure on page 13-2 to preserve the existing transmission settings.
- Step 3** Perform any of the following tasks as needed:
- [DLP-G333 Change the 10G Data Muxponder Client Line Settings, page 5-99](#)
 - [DLP-G334 Change the 10G Data Muxponder Distance Extension Settings, page 5-101](#)
 - [DLP-G340 Change the 10G Data Muxponder Trunk Wavelength Settings, page 5-102](#)
 - [DLP-G335 Change the 10G Data Muxponder SONET \(OC-192\)/SDH \(STM-64\) Settings, page 5-103](#)
 - [DLP-G336 Change the 10G Data Muxponder Section Trace Settings, page 5-105](#)
 - [DLP-G341 Change the 10G Data Muxponder SONET or SDH Line Thresholds, page 5-106](#)
 - [DLP-G337 Change the 10G Data Muxponder Line RMON Thresholds for Ethernet, 1G FC/FICON, or ISC/ISC3 Payloads, page 5-108](#)
 - [DLP-G338 Provision the 10G Data Muxponder Trunk Port Alarm and TCA Thresholds, page 5-111](#)
 - [DLP-G339 Provision the 10G Data Muxponder Client Port Alarm and TCA Thresholds, page 5-112](#)
 - [DLP-G366 Change the 10G Data Muxponder OTN Settings, page 5-115](#)



Note To use the Alarm Profiles tab, including creating alarm profiles and suppressing alarms, see [Chapter 8, “Manage Alarms.”](#)

Stop. You have completed this procedure.

DLP-G333 Change the 10G Data Muxponder Client Line Settings

Purpose	This task changes the line settings for the MXP_MR_10DME_C and MXP_MR_10DME_L muxponder cards.
Tools/Equipment	None
Prerequisite Procedures	DLP-G46 Log into CTC, page 2-25
Required/As Needed	As needed
Onsite/Remote	Onsite or remote
Security Level	Provisioning or higher

- Step 1** In node view (single-shelf mode) or shelf view (multishelf view), double-click the MXP_MR_10DME_C or MXP_MR_10DME_L card where you want to change the line settings.
- Step 2** Click the **Provisioning > Line > Client** tabs. Tabs and parameter selections vary according to PPM provisioning.
- Step 3** Modify any of the settings for the Client tab as described in [Table 5-56](#).

Table 5-56 MXP_MR_10DME_C or MXP_MR_10DME_L Card Line Client Settings

Parameter	Description	Options
Port	(Display only) Port number.	1 through 8
Port Name	The user can assign a logical name for each of the ports shown by filling in this field.	User-defined. Name can be up to 32 alphanumeric/ special characters. Blank by default. See the “ DLP-G104 Assign a Name to a Port ” task on page 7-3.
Admin State	Sets the port service state unless network conditions prevent the change. For more information about administrative states, refer to the Appendix B, “Administrative and Service States” in the <i>Cisco ONS 15454 DWDM Reference Manual</i> .	<ul style="list-style-type: none"> IS (ANSI) or Unlocked (ETSI) OOS,DSBLD (ANSI) or Locked,disabled (ETSI) OOS,MT (ANSI) or Locked,maintenance (ETSI)
Service State	(Display only) Identifies the autonomously generated state that gives the overall condition of the port. Service states appear in the format: Primary State-Primary State Qualifier, Secondary State. For more information about service states, refer to Appendix B, “Administrative and Service States” in the <i>Cisco ONS 15454 DWDM Reference Manual</i> .	<ul style="list-style-type: none"> IS-NR (ANSI) or Unlocked-enabled (ETSI) OOS-AU,AINS (ANSI) or Unlocked-disabled, automaticInService (ETSI) OOS-MA,DSBLD (ANSI) or Locked-enabled,disabled (ETSI) OOS-MA,MT (ANSI) or Locked-enabled,maintenance (ETSI)
ALS Mode	Sets the ALS function mode.	<ul style="list-style-type: none"> Disabled (default): ALS is off; the laser is not automatically shut down when traffic outages (LOS) occur. Manual Restart: ALS is on; the laser automatically shuts down when traffic outages (LOS) occur. However, the laser must be manually restarted when conditions that caused the outage are resolved. Manual Restart for Test: Manually restarts the laser for testing.

Table 5-56 MXP_MR_10DME_C or MXP_MR_10DME_L Card Line Client Settings (continued)

Parameter	Description	Options
Reach	Sets the optical reach distance of the client port.	<p>The reach distances that appear in the drop-down list depend on the card:</p> <ul style="list-style-type: none"> • Autoprovision—The system to automatically provision the reach from the pluggable port module (PPM) reach value on the hardware. • SX—Short laser wavelength on multimode fiber optic cable for a maximum length of 550 meters. The operating wavelength range is 770-860 nm.) • LX—Long wavelength for a long haul fiber optic cable for a maximum length of 10 km. The operating wavelength range is 1270-1355 nm.) • CX—Two pairs of 150-ohm shielded twisted pair cable for a maximum length of 25 meters.) • T—Four pairs of Category 5 Unshielded Twisted Pair cable for a maximum length of 100 meters.) • DX—Single mode up to 40 km. The operating wavelength range is 1430-1580 nm.) • HX—Single mode up to 40 km. The operating wavelength range is 1280-1335 nm.) • ZX—Extended wavelength single-mode optical fiber for up to 100 km. The operating wavelength range is 1500-1580 nm.) • VX—Single mode up to 100 km. The operating wavelength range is 1500-1580 nm.)
Wavelength	Displays the wavelength of the client port.	<ul style="list-style-type: none"> • First Tunable Wavelength • Further wavelengths: 850 nm through 1560.61 nm 100-GHz ITU spacing CWDM spacing
Squelch	Shuts down the far-end laser in response to certain defects. (Squelch does not apply to ISC COMPACT payloads.)	<ul style="list-style-type: none"> • Squelch • Disable

Step 4 Click **Apply**.

Step 5 Return to your originating procedure (NTP).

DLP-G334 Change the 10G Data Muxponder Distance Extension Settings

Purpose	This task changes the distance extension settings for the MXP_MR_10DME_C and MXP_MR_10DME_L muxponder card ports provisioned for Fibre Channel or FICON payloads.
Tools/Equipment	None
Prerequisite Procedures	DLP-G46 Log into CTC, page 2-25
Required/As Needed	As needed
Onsite/Remote	Onsite or remote
Security Level	Provisioning or higher



Note The distance extension parameters only apply to client ports (Ports 1 to 8) and not to the trunk port (Port 9).



Note Cisco recommends enabling distance extension for the MXP_MR_10DME_C cards at all times. Distance extension should only be disabled in special circumstances, for example when the card is not facing a switch, router, or data storage equipment.

- Step 1** In node view (single-shelf mode) or shelf view (multishelf view), double-click the MXP_MR_10DME_C or MXP_MR_10DME_L card where you want to change the distance extension settings.
- Step 2** Click the **Provisioning > Line > Distance Extension** tabs.
- Step 3** Modify any of the settings for the Distance Extension tab as described in [Table 5-57](#).

Table 5-57 *MXP_MR_10DME_C or MXP_MR_10DME_L Card Line Distance Extension Settings*

Parameter	Description	Options
Port	(Display only) Port number. Up to eight ports might appear based on the number of pluggable port modules that are provisioned.	—
Enable Distance Extension	Allows end-to-end distances of up to 1600 km for FC1G and up to 800 km for FC2G. If Distance Extension is enabled, set the connected Fibre Channel switches to Interop or Open Fabric mode, depending on the Fibre Channel switch. By default, the MXP_MR_10DME_C and MXP_MR_10DME_L card will interoperate with the Cisco MDS storage products. Note: Cisco recommends that this box always remain checked.	<ul style="list-style-type: none"> Checked—(Default) Distance extension is enabled. Unchecked—Distance extension is not enabled.

- Step 4** Click **Apply**.

Step 5 Return to your originating procedure (NTP).

DLP-G340 Change the 10G Data Muxponder Trunk Wavelength Settings

Purpose	This task changes the trunk wavelength settings for the MXP_MR_10DME_C and MXP_MR_10DME_L.
Tools/Equipment	None
Prerequisite Procedures	DLP-G46 Log into CTC, page 2-25
Required/As Needed	As needed
Onsite/Remote	Onsite or remote
Security Level	Provisioning or higher

- Step 1** In node view (single-shelf mode) or shelf view (multishelf view), double-click the MXP_MR_10DME_C or MXP_MR_10DME_L card where you want to change the trunk wavelength settings.
- Step 2** Click the **Provisioning > Line > Wavelength Trunk Settings** tabs.
- Step 3** Modify any of the settings for the Wavelength Trunk Settings tab as described in [Table 5-58](#).

Table 5-58 MXP_MR_10DME_C or MXP_MR_10DME_L Card Wavelength Trunk Settings

Parameter	Description	Options
Port	(Display only) Displays the port number.	Port 9 (Trunk)
Band	Indicates the wavelength band that can be provisioned. The field is display-only when a physical MXP_MR_10DME_C or MXP_MR_10DME_L is installed. If the card is provisioned in CTC only, you can provision the band for the card that will be installed.	<ul style="list-style-type: none"> C—The C-band wavelengths are available in the Wavelength field. L—The L-band wavelengths are available in the Wavelength field.
Even/Odd	Sets the wavelengths available for provisioning.	<ul style="list-style-type: none"> Even—Displays even C-band or L-band wavelengths in the Wavelength field. Odd—Displays odd C-band or L-band wavelengths in the Wavelength field.
Wavelength	The wavelength provisioned for the trunk.	<ul style="list-style-type: none"> First Tunable Wavelength Further wavelengths in 100-GHz ITU spacing

- Step 4** Click **Apply**.
- Step 5** Return to your originating procedure (NTP).

DLP-G335 Change the 10G Data Muxponder SONET (OC-192)/SDH (STM-64) Settings

Purpose	This task changes the OC-192 (ANSI)/STM-64 (ETSI) settings for the MXP_MR_10DME_C and MXP_MR_10DME_L muxponder cards.
Tools/Equipment	None
Prerequisite Procedures	DLP-G46 Log into CTC, page 2-25
Required/As Needed	As needed
Onsite/Remote	Onsite or remote
Security Level	Provisioning or higher

- Step 1** In node view (single-shelf mode) or shelf view (multishelf view), double-click the MXP_MR_10DME_C or MXP_MR_10DME_L card where you want to change the SONET (OC-192)/SDH (STM-64) settings.
- Step 2** Click the **Provisioning > Line > SONET (ANSI) or SDH (ETSI)**. Tabs and parameter selections vary according to PPM provisioning.
- Step 3** Modify any of the settings for the SONET or SDH tab as described in [Table 5-59](#).

Table 5-59 MXP_MR_10DME_C or MXP_MR_10DME_L Card Line SONET or SDH Settings

Parameter	Description	Options
Port	(Display only) Port number.	9 (Trunk)
Port Name	Provides the ability to assign the specified port a name.	User-defined. Name can be up to 32 alphanumeric/special characters. Blank by default. See the “ DLP-G104 Assign a Name to a Port ” task on page 7-3 .
Admin State	Sets the port service state unless network conditions prevent the change. For more information about administrative states, refer to the “Administrative and Service States” appendix in the <i>Cisco ONS 15454 DWDM Reference Manual</i> .	<ul style="list-style-type: none"> IS (ANSI) or Unlocked (ETSI) IS,AINS (ANSI) or Unlocked,automaticInService (ETSI) OOS,DSBLD (ANSI) or Locked,disabled (ETSI) OOS,MT (ANSI) or Locked,maintenance (ETSI)
Service State	(Display only) Identifies the autonomously generated state that gives the overall condition of the port. Service states appear in the format: Primary State-Primary State Qualifier, Secondary State. For more information about service states, refer to the “Administrative and Service States” appendix in the <i>Cisco ONS 15454 DWDM Reference Manual</i> .	<ul style="list-style-type: none"> IS-NR (ANSI) or Unlocked-enabled (ETSI) OOS-AU,AINS (ANSI) or Unlocked-disabled, automaticInService (ETSI) OOS-MA,DSBLD (ANSI) or Locked-enabled,disabled (ETSI) OOS-MA,MT (ANSI) or Locked-enabled,maintenance (ETSI)
SF BER ¹	Sets the signal fail bit error rate.	<ul style="list-style-type: none"> 1E-3 1E-4 1E-5

Table 5-59 MXP_MR_10DME_C or MXP_MR_10DME_L Card Line SONET or SDH Settings (continued)

Parameter	Description	Options
SD BER ¹	Sets the signal degrade bit error rate.	<ul style="list-style-type: none"> • 1E-5 • 1E-6 • 1E-7 • 1E-8 • 1E-9
Type	The optical transport type.	<ul style="list-style-type: none"> • SONET (ANSI) • SDH (ETSI)
ALS Mode	Sets the ALS function mode. The DWDM transmitter supports ALS according to ITU-T G.644 (06/99). ALS can be disabled or can be set for one of three mode options.	<ul style="list-style-type: none"> • Disabled (default): ALS is off; the laser is not automatically shut down when traffic outages (LOS) occur. • Auto Restart: ALS is on; the laser automatically shuts down when traffic outages (LOS) occur. It automatically restarts when the conditions that caused the outage are resolved. • Manual Restart: ALS is on; the laser automatically shuts down when traffic outages (LOS) occur. However, the laser must be manually restarted when conditions that caused the outage are resolved. • Manual Restart for Test: Manually restarts the laser for testing.
AINS Soak	Sets the automatic in-service soak period. Double-click the time and use the up and down arrows to change settings.	<ul style="list-style-type: none"> • Duration of valid input signal, in hh.mm format, after which the card becomes in service (IS) automatically • 0 to 48 hours, 15-minute increments
ProvidesSync	Sets the ProvidesSync card parameter. If checked, the card is provisioned as a NE timing reference.	Checked or unchecked
SyncMsgIn	Sets the EnableSync card parameter. Enables synchronization status messages (S1 byte), which allow the node to choose the best timing source.	Checked or unchecked
Send DoNotUse	Sets the Send DoNotUse card state. When checked, sends a DUS (do not use) message on the S1 byte.	Checked or unchecked

1. SF BER and SD BER thresholds apply only to trunk ports (Port 9 for MXP_MR_2.5G and Ports 9 and 10 for MXPP_MR_2.5G).

Step 4 Click **Apply**.

Step 5 Return to your originating procedure (NTP).

DLP-G336 Change the 10G Data Muxponder Section Trace Settings

Purpose	This task changes the section trace settings for the MXP_MR_10DME_C and MXP_MR_10DME_L muxponder cards.
Tools/Equipment	None
Prerequisite Procedures	DLP-G46 Log into CTC, page 2-25
Required/As Needed	As needed
Onsite/Remote	Onsite or remote
Security Level	Provisioning or higher

- Step 1** In node view (single-shelf mode) or shelf view (multishelf view), double-click the MXP_MR_10DME_C or MXP_MR_10DME_L card where you want to change the section trace settings.
- Step 2** Click the **Provisioning > Line > Section Trace** tabs. Tabs and parameter selections vary according to PPM provisioning.
- Step 3** Modify any of the settings in the Section Trace tab as described in [Table 5-60](#).

Table 5-60 MXP_MR_10DME_C or MXP_MR_10DME_L Card Line Section Trace Settings

Parameter	Description	Options
Port	(Display only) Port number.	<ul style="list-style-type: none"> 9 (trunk only)
Received Trace Mode	Sets the received trace mode.	<ul style="list-style-type: none"> Off/None Manual
Disable AIS/RDI on TIM-S	If a TIM on section overhead alarm arises because of a J0 overhead string mismatch, no alarm indication signal is sent to downstream nodes if this box is checked.	<ul style="list-style-type: none"> Checked (AIS/RDI on TIM-S is disabled) Unchecked (AIS/RDI on TIM-S is not disabled)
Transmit Section Trace String Size	Sets the trace string size.	<ul style="list-style-type: none"> 1 byte 16 byte
Transmit	Displays the current transmit string; sets a new transmit string. You can click the button on the right to change the display. Its title changes, based on the current display mode. Click Hex to change the display to hexadecimal (button changes to ASCII); click ASCII to change the display to ASCII (button changes to Hex).	String of trace string size
Expected	Displays the current expected string; sets a new expected string. You can click the button on the right to change the display. Its title changes, based on the current display mode. Click Hex to change the display to hexadecimal (button changes to ASCII); click ASCII to change the display to ASCII (button changes to Hex).	String of trace string size
Received	(Display only) Displays the current received string. You can click Refresh to manually refresh this display, or select the Auto-refresh every 5 sec check box to keep this panel updated.	String of trace string size
Auto-refresh	If checked, automatically refreshes the display every 5 seconds.	Checked/unchecked (default)

- Step 4** Click **Apply**.
- Step 5** Return to your originating procedure (NTP).

DLP-G341 Change the 10G Data Muxponder SONET or SDH Line Thresholds

Purpose	This task changes the SONET or SDH line threshold settings for the MXP_MR_10DME_C and MXP_MR_10DME_L muxponder cards.
Tools/Equipment	None
Prerequisite Procedures	DLP-G46 Log into CTC, page 2-25
Required/As Needed	As needed
Onsite/Remote	Onsite or remote
Security Level	Provisioning or higher

- Step 1** In node view (single-shelf mode) or shelf view (multishelf view), double-click the MXP_MR_10DME_C or MXP_MR_10DME_L card where you want to change the line threshold settings.
- Step 2** Click the **Provisioning > Line Thresholds > SONET Thresholds (ANSI)** or **SDH Thresholds (ETSI)** tabs.
- Step 3** Modify any of the settings as shown in [Table 5-61](#).



Note You must modify Near End and Far End independently; 15 Min and 1 Day independently; and Line and Section independently. To do so, choose the appropriate radio button and click **Refresh**.



Note In [Table 5-61](#), some parameters and options do not apply to all 4x2.5G muxponder cards. If the parameter or options do not apply, they do not appear in CTC.

Table 5-61 MXP_MR_10DME_C or MXP_MR_10DME_L Card Line Threshold Settings

Parameter	Description	Options - ONS 15454	Options - ONS 15454 SDH
Port	(Display only) Port number	<ul style="list-style-type: none"> 9 (Trunk) 	<ul style="list-style-type: none"> 9 (Trunk)
EB	Path Errored Block indicates that one or more bits are in error within a block	Numeric. Threshold display options include: <ul style="list-style-type: none"> Direction—Near End or Far End Interval—15 Min (minutes) or 1 day Types—Line or Section (near end only) Choose an option in each category and click Refresh .	Numeric. Threshold display options include: <ul style="list-style-type: none"> Direction—Near End or Far End Interval—15 Min (minutes) or 1 day Types—Multiplex Section or Regeneration Section (near end only) Choose an option in each category and click Refresh .

Table 5-61 MXP_MR_10DME_C or MXP_MR_10DME_L Card Line Threshold Settings (continued)

Parameter	Description	Options - ONS 15454	Options - ONS 15454 SDH
CV	Coding violations	Numeric. Threshold display options include: <ul style="list-style-type: none"> • Direction—Near End or Far End • Interval—15 Min (minutes) or 1 day • Types—Line or Section (near end only) Choose an option in each category and click Refresh .	Numeric. Threshold display options include: <ul style="list-style-type: none"> • Direction—Near End or Far End • Interval—15 Min (minutes) or 1 day • Types—Multiplex Section or Regeneration Section (near end only) Choose an option in each category and click Refresh .
ES	Errored seconds	Numeric. Threshold display options include: <ul style="list-style-type: none"> • Direction—Near End or Far End • Interval—15 Min (minutes) or 1 day • Types—Line or Section (near end only) Choose an option in each category and click Refresh .	Numeric. Threshold display options include: <ul style="list-style-type: none"> • Direction—Near End or Far End • Interval—15 Min (minutes) or 1 day • Types—Multiplex Section or Regeneration Section (near end only) Choose an option in each category and click Refresh .
SES	Severely errored seconds	Numeric. Threshold display options include: <ul style="list-style-type: none"> • Direction—Near End or Far End • Interval—15 Min (minutes) or 1 day • Types—Line or Section (near end only) Choose an option in each category and click Refresh .	Numeric. Threshold display options include: <ul style="list-style-type: none"> • Direction—Near End or Far End • Interval—15 Min (minutes) or 1 day • Types—Multiplex Section or Regeneration Section (near end only) Choose an option in each category and click Refresh .
SEFS	(Near End Section or Regeneration Section only) Severely errored framing seconds	Numeric. Threshold display options include: <ul style="list-style-type: none"> • Direction—Near End or Far End • Interval—15 Min (minutes) or 1 day • Types—Line or Section (near end only) Choose an option in each category and click Refresh .	Numeric. Threshold display options include: <ul style="list-style-type: none"> • Direction—Near End or Far End • Interval—15 Min (minutes) or 1 day • Types—Multiplex Section or Regeneration Section (near end only) Choose an option in each category and click Refresh .
BBE	Background block errors	Numeric. Threshold display options include: <ul style="list-style-type: none"> • Direction—Near End or Far End • Interval—15 Min (minutes) or 1 day • Types—Line or Section (near end only) Choose an option in each category and click Refresh .	Numeric. Threshold display options include: <ul style="list-style-type: none"> • Direction—Near End or Far End • Interval—15 Min (minutes) or 1 day • Types—Multiplex Section or Regeneration Section (near end only) Choose an option in each category and click Refresh .

Table 5-61 MXP_MR_10DME_C or MXP_MR_10DME_L Card Line Threshold Settings (continued)

Parameter	Description	Options - ONS 15454	Options - ONS 15454 SDH
FC	(Line or Multiplex Section only) Failure count	Numeric. Threshold display options include: <ul style="list-style-type: none"> Direction—Near End or Far End Interval—15 Min (minutes) or 1 day Types—Line or Section (near end only) Choose an option in each category and click Refresh .	Numeric. Threshold display options include: <ul style="list-style-type: none"> Direction—Near End or Far End Interval—15 Min (minutes) or 1 day Types—Multiplex Section or Regeneration Section (near end only) Choose an option in each category and click Refresh .
UAS	(Line or Multiplex Section only) Unavailable seconds	Numeric. Threshold display options include: <ul style="list-style-type: none"> Direction—Near End or Far End Interval—15 Min (minutes) or 1 day Types—Line or Section (near end only) Choose an option in each category and click Refresh .	Numeric. Threshold display options include: <ul style="list-style-type: none"> Direction—Near End or Far End Interval—15 Min (minutes) or 1 day Types—Multiplex Section or Regeneration Section (near end only) Choose an option in each category and click Refresh .

Step 4 Click **Apply**.

Step 5 Return to your originating procedure (NTP).

DLP-G337 Change the 10G Data Muxponder Line RMON Thresholds for Ethernet, 1G FC/FICON, or ISC/ISC3 Payloads

Purpose	This task changes the line threshold settings for MXP_MR_10DME_C and MXP_MR_10DME_L cards carrying Ethernet, FC/FICON, or ISC/ISC3 payloads.
Tools/Equipment	None
Prerequisite Procedures	DLP-G46 Log into CTC, page 2-25
Required/As Needed	As needed
Onsite/Remote	Onsite or remote
Security Level	Provisioning or higher

Step 1 In node view (single-shelf mode) or shelf view (multishelf view), display the MXP_MR_10DME_C or MXP_MR_10DME_L card where you want to change the line threshold settings in card view.

Step 2 Click the **Provisioning > Line Thresholds > RMON Thresholds** tabs.

Step 3 Click **Create**. The Create Threshold dialog box appears.

Step 4 From the Port drop-down list, choose the applicable port, either the payload port, for example “1-1 (ONE_GE)”, or the equivalent ITU-T G.7041 GFP (Generic Frame Procedure) port.

- Step 5** From the Variable drop-down list, choose an Ethernet, FC, FICON, or ISC variable. See [Table 5-62](#) for a list of available Ethernet variables, [Table 5-63](#) for a list of FC and FICON variables, and [Table 5-64](#) for a list of ISC and ISC3 variables.

Table 5-62 *MXP_MR_10DME_C or MXP_MR_10DME_L Ethernet Variables*

Variable	Description
ifInOctets	Number of bytes received since the last counter reset.
rxTotalPkts	Total number of receive packets.
ifInErrors	Total number of receive errors.
ifOutOctets	The total number of octets transmitted out of the interface, including framing characters.
txTotalPkts	Total number of transmitted packets.
mediaIndStatsRxFramesTruncated	Total number of frames received that are less than 5 bytes. This value is a part of HDLC and GFP port statistics.
mediaIndStatsRxFramesTooLong	Number of received frames that exceed the MTU. This value is part of HDLC and GFP port statistics.
mediaIndStatsRxFramesBadCRC	Number of receive data frames with payload CRC errors when HDLC framing is used.
mediaIndStatsTxFramesBadCRC	Number of transmitted data frames with payload CRC errors when HDLC framing is used.
8b10bInvalidOrderedSetsDispErrorsSum	Number of code violations/running disparity errors in the 8b/10b encoded characters received.

Table 5-63 *MXP_MR_10DME_C or MXP_MR_10DME_L FC/FICON Variables*

Variable	Description
ifInOctets	Number of bytes received since the last counter reset.
rxTotalPkts	Total number of receive packets.
ifInErrors	Total number of receive errors.
ifOutOctets	The total number of octets transmitted out of the interface, including framing characters.
txTotalPkts	Total number of transmitted packets.
ifOutOversizePkts	Total number of oversized packets output from the interface.
mediaIndStatsRxFramesTruncated	Total number of frames received that are less than 5 bytes. This value is a part of HDLC and GFP port statistics.
mediaIndStatsRxFramesTooLong	Number of received frames that exceed the MTU. This value is part of HDLC and GFP port statistics.
mediaIndStatsRxFramesBadCRC	Number of receive data frames with payload CRC errors when HDLC framing is used.
mediaIndStatsTxFramesBadCRC	Number of transmitted data frames with payload CRC errors when HDLC framing is used.
fcStatsZeroTxCredits	This is a count that increments when the FC/FICON Tx credits go from a non-zero value to zero.

Table 5-63 *MXP_MR_10DME_C or MXP_MR_10DME_L FC/FICON Variables (continued)*

fcStatsRxRecvrReady	Number of received RDY (Receive Ready) order set.
fcStatsTxRecvrReady	Number of transmitted RDY (Receive Ready) order set.
8b10bInvalidOrderedSetsDispErrorsSum	Number of Code Violations/Running Disparity errors in the 8b/10b encoded characters received

Table 5-64 *MXP_MR_10DME_C or MXP_MR_10DME_L ISC and ISC3Variables*

Variable	Description
ifInOctets	Number of bytes received since the last counter reset.
rxTotalPkts	Total number of receive packets.
ifOutOctets	The total number of octets transmitted out of the interface, including framing characters.
txTotalPkts	Total number of transmitted packets.

Step 6 From the Alarm Type drop-down list, indicate whether the event will be triggered by the rising threshold, the falling threshold, or both the rising and falling thresholds.

Step 7 From the Sample Type drop-down list, choose either **Relative** or **Absolute**. Relative restricts the threshold to use the number of occurrences in the user-set sample period. Absolute sets the threshold to use the total number of occurrences, regardless of time period.

Step 8 Type in an appropriate number of seconds for the Sample Period.

Step 9 Type in the appropriate number of occurrences for the Rising Threshold.

For a rising type of alarm, the measured value must move from below the falling threshold to above the rising threshold. For example, if a network is running below a rising threshold of 1000 collisions every 15 seconds and a problem causes 1001 collisions in 15 seconds, the excess occurrences trigger an alarm.

Step 10 Enter the appropriate number of occurrences in the Falling Threshold field. In most cases a falling threshold is set lower than the rising threshold.

A falling threshold is the counterpart to a rising threshold. When the number of occurrences is above the rising threshold and then drops below a falling threshold, it resets the rising threshold. For example, when the network problem that caused 1001 collisions in 15 seconds subsides and creates only 799 collisions in 15 seconds, occurrences fall below a falling threshold of 800 collisions. This resets the rising threshold so that if network collisions again spike over a 1000 per 15-second period, an event again triggers when the rising threshold is crossed. An event is triggered only the first time a rising threshold is exceeded (otherwise, a single network problem might cause a rising threshold to be exceeded multiple times and cause a flood of events).

Step 11 Click **OK**.

Step 12 To view all RMON thresholds, click **Show All RMON thresholds**. If not, continue with [Step 13](#)

Step 13 Return to your originating procedure (NTP).

DLP-G338 Provision the 10G Data Muxponder Trunk Port Alarm and TCA Thresholds

Purpose	This task changes the MXP_MR_10DME_C and MXP_MR_10DME_L trunk port alarm and TCA thresholds.
Tools/Equipment	None
Prerequisite Procedures	DLP-G46 Log into CTC, page 2-25
Required/As Needed	As needed
Onsite/Remote	Onsite or remote
Security Level	Provisioning or higher

Step 1 In node view (single-shelf mode) or shelf view (multishelf view), double-click the MXP_MR_10DME_C or MXP_MR_10DME_L card where you want to change the trunk port alarm and TCA settings.

Step 2 Click the **Provisioning > Optics Thresholds** tabs.



Note You must modify 15 Min and 1 Day independently. To do so, choose the appropriate radio button and click **Refresh**.



Note Do not modify the Laser Bias parameters.

Step 3 If TCA is not selected, click **TCA** and then click Refresh. If it is selected, continue with [Step 4](#).

Step 4 Provision the trunk port (Port 9) TCA thresholds as follows:

- RX Power High: -9 dBm
- RX Power Low: -18 dBm
- TX Power High: 9 dBm
- TX Power Low: 0 dBm

Step 5 Under Types, click the **Alarm** radio button and click **Refresh**.



Note Do not modify the Laser Bias parameters.

Step 6 Provision the trunk port (Port 9) Alarm thresholds as follows:

- RX Power High: -8 dBm
- RX Power Low: -20 dBm
- TX Power High: 7 dBm
- TX Power Low: 3 dBm



Note You must modify 15 Min and 1 Day independently. To do so, choose the appropriate radio button and click **Refresh**.

- Step 7** Click **Apply**.
- Step 8** Return to your originating procedure (NTP).

DLP-G339 Provision the 10G Data Muxponder Client Port Alarm and TCA Thresholds

Purpose	This task provisions the client port alarm and TCA thresholds for the MXP_MR_10DME_C and MXP_MR_10DME_L cards.
Tools/Equipment	None
Prerequisite Procedures	DLP-G278 Provision the Optical Line Rate, page 5-9 DLP-G46 Log into CTC, page 2-25
Required/As Needed	Required
Onsite/Remote	Onsite or remote
Security Level	Provisioning or higher

- Step 1** In node view (single-shelf mode) or shelf view (multishelf view), double-click the MXP_MR_10DME_C and MXP_MR_10DME_L card where you want to change the client port alarm and TCA settings.
- Step 2** Click the **Provisioning > Optics Thresholds** tabs. The TCA thresholds are shown by default.
- Step 3** Referring to [Table 5-65](#), provision the client ports (Ports 1 through 8) TCA thresholds for RX Power High, RX Power Low, TX Power High, and TX Power Low based on the client interface at the other end. For additional information about client SFP and XFP interfaces, also known as Pluggable Port Modules (PPMs), refer to the “Hardware Specifications” appendix in the *Cisco ONS 15454 DWDM Reference Manual*.



Note Do not modify the Laser Bias parameters.



Note You must modify 15 Min and 1 Day independently. To do so, choose the appropriate radio button and click **Refresh**.



Note The PPM port rate can be viewed on the Provisioning > Pluggable Port Modules tab. For more information about SFPs and XFPs, refer to the “Hardware Specifications” chapter in the *Cisco ONS 15454 DWDM Reference Manual*, or the *Installing GBIC, SFP and XFP Optics Modules in Cisco ONS 15454, 15454 SDH, 15327, 15600, and 15310-CL Platforms* document available in the ONS 15454 production documentation website on www.cisco.com.

Table 5-65 MXP_MR_10DME_C and MXP_MR_10DME_L Card Client Interfaces TCA Thresholds

PPM Port Rate	Pluggable Port Module (XFP)	TCA RX Power High	TCA RX Power Low	TCA TX Power High	TCA TX Power Low
FC1G	15454-SFP-GEFC-SX 15454E-SFP-GEFC-S ONS-SE-G2F-SX	0	-17	3	-16
	15454-SFP-GE+-LX 15454E-SFP-GE+-LX ONS-SE-G2F-LX	-3	-20	3	-16
FC2G	15454-SFP-GEFC-SX 15454E-SFP-GEFC-S ONS-SE-G2F-SX	0	-15	3	-16
	15454-SFP-GE+-LX 15454E-SFP-GE+-LX ONS-SE-G2F-LX	-3	-20	3	-16
FICON1G	15454-SFP-GEFC-SX 15454E-SFP-GEFC-S ONS-SE-G2F-SX	0	-17	3	-16
	15454-SFP-GE+-LX 15454E-SFP-GE+-LX ONS-SE-G2F-LX	-3	-20	3	-16
FICON2G	15454-SFP-GEFC-SX 15454E-SFP-GEFC-S ONS-SE-G2F-SX	0	-17	3	-16
	15454-SFP-GE+-LX 15454E-SFP-GE+-LX ONS-SE-G2F-LX	-3	-20	3	-16
ISC3 PEER 1G	ONS-SE-G2F-SX	0	-17	3	-16
	ONS-SE-G2F-LX	0	-20	3	-16
ISC3 PEER 2G					
FC4G	ONS-SE-4G-MM	0	-12	4	-15
	ONS-SE-4G-SM	-1	-15	4	-15
FICON4G	ONS-SE-4G-MM	0	-12	4	-15
	ONS-SE-4G-SM	-1	-15	4	-15

Step 4 Click **Apply**.

Step 5 Repeat Steps 3 and 4 to provision each additional client port.

Step 6 Under Types, click the **Alarm** radio button and click **Refresh**.

Step 7 Referring to Table 5-66, provision the client port (Ports 1 through 8) Alarm thresholds for RX Power High, RX Power Low, TX Power High, and TX Power Low based on the client interface that is provisioned.



Note You must modify 15 Min and 1 Day independently. To do so, choose the appropriate radio button and click **Refresh**.

Table 5-66 *MXP_MR_10DME_C and MXP_MR_10DME_L Card Client Interface Alarm Thresholds*

PPM Port Rate	Pluggable Port Module (XFP)	Alarm RX Power Low	Alarm RX Power High	Alarm TX Power Low	Alarm TX Power High
FC1G	15454-SFP-GEFC-SX 15454E-SFP-GEFC-S ONS-SE-G2F-SX	-20	3	-13	-1
	15454-SFP-GE+-LX 15454E-SFP-GE+-LX ONS-SE-G2F-LX	-23	0	-13	0
FC2G	15454-SFP-GEFC-SX 15454E-SFP-GEFC-S ONS-SE-G2F-SX	-18	3	-13	-1
	15454-SFP-GE+-LX 15454E-SFP-GE+-LX ONS-SE-G2F-LX	-23	0	-13	0
FICON1G	15454-SFP-GEFC-SX 15454E-SFP-GEFC-S ONS-SE-G2F-SX	-20	3	-13	-1
	15454-SFP-GE+-LX 15454E-SFP-GE+-LX ONS-SE-G2F-LX	-23	0	-13	0
FICON2G	15454-SFP-GEFC-SX 15454E-SFP-GEFC-S ONS-SE-G2F-SX	-20	3	-13	-1
	15454-SFP-GE+-LX 15454E-SFP-GE+-LX ONS-SE-G2F-LX	-23	0	-13	0
ISC3 PEER 1G	ONS-SE-G2F-SX	-20	3	-13	-1
	ONS-SE-G2F-LX	-23	0	-13	0
ISC3 PEER 2G					
FC4G	ONS-SE-4G-MM	-15	3	-11	-1
	ONS-SE-4G-SM	-18	2	-11	0
FICON4G	ONS-SE-4G-MM	-15	3	-11	-1
	ONS-SE-4G-SM	-18	2	-11	0

Step 8 Click **Apply**.

Step 9 Repeat Steps 7 and 8 to provision each additional client port. When you have finished provisioning client ports, continue with [Step 10](#).

Step 10 Return to your originating procedure (NTP).

DLP-G366 Change the 10G Data Muxponder OTN Settings

Purpose	This task changes the OTN settings for the MXP_MR_10DME_C and MXP_MR_10DME_L cards.
Tools/Equipment	None
Prerequisite Procedures	DLP-G46 Log into CTC, page 2-25
Required/As Needed	As needed
Onsite/Remote	Onsite or remote
Security Level	Provisioning or higher

- Step 1** In node view (single-shelf mode) or shelf view (multishelf view), double-click the MXP_MR_10DME_C and MXP_MR_10DME_L card where you want to change the OTN settings.
- Step 2** Click the **Provisioning > OTN** tabs, then choose one of the following subtabs: **OTN Lines**, **G.709 Thresholds**, **FEC Thresholds**, or **Trail Trace Identifier**.
- Step 3** Modify any of the settings described in Tables [5-15](#) through [5-18](#).



Note You must modify Near End and Far End; 15 Min and 1 Day; and SM and PM independently. To do so, choose the appropriate radio button and click **Refresh**.

[Table 5-67](#) describes the values on the Provisioning > OTN > OTN Lines tab.

Table 5-67 MXP_MR_10DME_C and MXP_MR_10DME_L Card OTN Line Settings

Parameter	Description	Options
Port	(Display only) Displays the port number.	9 (Trunk)
G.709 OTN	Sets the OTN lines according to ITU-T G.709.	<ul style="list-style-type: none"> • Enable • Disable
FEC	Sets the OTN lines to forward error correction (FEC).	<ul style="list-style-type: none"> • Standard • Enhanced
SF BER	(Display only) Sets the signal fail bit error rate.	<ul style="list-style-type: none"> • 1E-5
SD BER	Sets the signal degrade bit error rate.	<ul style="list-style-type: none"> • 1E-5 • 1E-6 • 1E-7 • 1E-8 • 1E-9
Asynch/Synch Mapping	Sets how the ODUk (client payload) is mapped to the optical channel (OTUk).	<ul style="list-style-type: none"> • Asynch mapping • Synch mapping

Table 5-68 describes the values on the Provisioning > OTN > G.709 Thresholds tab.

Table 5-68 MXP_MR_10DME_C and MXP_MR_10DME_L Card ITU-T G.709 Threshold Settings

Parameter	Description	Options
Port ¹	(Display only) Port number.	9 (Trunk)
ES	Errored seconds	Numeric. Can be set for Near End or Far End, for 15-minute or one-day intervals, or for SM (OTUk) or PM (ODUk). Select a bullet and click Refresh .
SES	Severely errored seconds	Numeric. Can be set for Near End or Far End, for 15-minute or one-day intervals, or for SM (OTUk) or PM (ODUk). Select a bullet and click Refresh .
UAS	Unavailable seconds	Numeric. Can be set for Near End or Far End, for 15-minute or one-day intervals, or for SM (OTUk) or PM (ODUk). Select a bullet and click Refresh .
BBE	Background block errors	Numeric. Can be set for Near End or Far End, for 15-minute or one-day intervals, or for SM (OTUk) or PM (ODUk). Select a bullet and click Refresh .
FC	Failure counter	Numeric. Can be set for Near End or Far End, for 15-minute or one-day intervals, or for SM (OTUk) or PM (ODUk). Select a bullet and click Refresh .

1. Latency for a 1G-FC payload without ITU-T G.709 is 4 microseconds, and with ITU-T G.709 is 40 microseconds. Latency for a 2G-FC payload without ITU-T G.709 is 2 microseconds, and with ITU-T G.709 is 20 microseconds. Consider these values when planning a FC network that is sensitive to latency.

Table 5-69 describes the values on the Provisioning > OTN > FEC Threshold tab.

Table 5-69 MXP_MR_10DME_C and MXP_MR_10DME_L Card FEC Threshold Settings

Parameter	Description	Options
Port	(Display only) Port number.	2
Bit Errors Corrected	Sets the value for bit errors corrected.	Numeric. Can be set for 15-minute or one-day intervals.
Uncorrectable Words	Sets the value for uncorrectable words.	Numeric. Can be set for 15-minute or one-day intervals.

Table 5-70 describes the values on the Provisioning > OTN > Trail Trace Identifier tab.

Table 5-70 MXP_MR_10DME_C and MXP_MR_10DME_L Card Trail Trace Identifier Settings

Parameter	Description	Options
Port	(Display only) Port number.	2
Level	Sets the level.	<ul style="list-style-type: none"> • Section • Path
Received Trace Mode	Sets the trace mode.	<ul style="list-style-type: none"> • Off/None • Manual

Table 5-70 *MXP_MR_10DME_C and MXP_MR_10DME_L Card Trail Trace Identifier Settings*

Parameter	Description	Options
Transmit	Displays the current transmit string; sets a new transmit string. You can click the button on the right to change the display. Its title changes, based on the current display mode. Click Hex to change the display to hexadecimal (button changes to ASCII); click ASCII to change the display to ASCII (button changes to Hex).	String of trace string size
Disable FDI on TTIM	If a Trace Identifier Mismatch on Section overhead alarm arises because of a J0 overhead string mismatch, no Forward Defect Indication (FDI) signal is sent to the downstream nodes if this box is checked.	<ul style="list-style-type: none"> • Checked (FDI on TTIM is disabled) • Unchecked (FDI on TTIM is not disabled)
Expected	Displays the current expected string; sets a new expected string. You can click the button on the right to change the display. Its title changes, based on the current display mode. Click Hex to change the display to hexadecimal (button changes to ASCII); click ASCII to change the display to ASCII (button changes to Hex).	String of trace string size
Received	(Display only) Displays the current received string. You can click Refresh to manually refresh this display, or check the Auto-refresh every 5 sec check box to keep this panel updated.	String of trace string size

Step 4 Click **Apply**.

Step 5 Return to your originating procedure (NTP).

NTP-G162 Change the TXP or MXP ALS Maintenance Settings

Purpose	This task changes the ALS maintenance settings for the TXP and MXP cards.
Tools/Equipment	None
Prerequisite Procedures	DLP-G46 Log into CTC, page 2-25
Required/As Needed	As needed
Onsite/Remote	Onsite or remote
Security Level	Provisioning or higher

**Note**

The automatic laser shutdown (ALS) function is normally disabled for TXP and MXP cards. Enable ALS only when TXP and MXP cards are directly connected to each other.

- Step 1** In node view (single-shelf mode) or shelf view (multishelf mode), double-click the TXP or MXP card where you want to change the ALS maintenance settings.
- Step 2** Click the **Maintenance > ALS** tabs.
- Step 3** Modify any of the settings described in [Table 5-71](#). The provisionable parameters are listed in the Options column in the table.

Table 5-71 ALS Settings

Parameter	Description	Options
OSRI	Optical safety remote interlock. When set to On, the TXP/MXP card TX output power is shut down.	From the drop-down list, choose one of the following: <ul style="list-style-type: none"> On Off
ALS Mode	Automatic laser shutdown. ALS provides the ability to shut down the TXP/MXP TX laser when the TXP/MXP RX detects an LOS.	From the drop-down list, choose one of the following: <ul style="list-style-type: none"> Disable—Deactivates ALS. Auto Restart—(Default) ALS is active. The power is automatically shut down when needed and automatically tries to restart using a probe pulse until the cause of the failure is repaired. Manual Restart Manual Restart for Test
Recovery Pulse Duration	(Display only) Displays the duration of the optical power pulse that begins when an amplifier restarts.	—
Recovery Pulse Interval	(Display only) Displays the interval between optical power pulses.	—
Currently Shutdown	(Display only) Displays the current status of the laser.	—
Request Laser Restart	If checked, allows you to restart the laser for maintenance.	Checked or unchecked

- Step 4** Click **Apply**. If the change affects traffic, a warning message displays. Click **Yes** to complete the change.
- Step 5** Return to your originating procedure (NTP).



Turn Up a Network

This chapter explains how to turn up and test a Cisco ONS 15454 dense wavelength division multiplexing (DWDM) network. For DWDM topology reference information and span loss tables, refer to the “Network Reference” chapter in the *Cisco ONS 15454 DWDM Reference Manual*.

There are two main DWDM network types: metro core, where the channel power is equalized and dispersion compensation is applied, and metro access, where the channels are not equalized and dispersion compensation is not applied. The DWDM network topologies supported are hubbed rings, multihubbed rings, meshed rings, linear configurations, and single-span links. The DWDM node types supported are hub, terminal, optical add/drop multiplexing (OADM), reconfigurable optical add/drop multiplexing (ROADM), anti-amplified spontaneous emissions (anti-ASE), and line amplifier. For DWDM and hybrid node turn-up procedures, see [Chapter 3, “Turn Up a Node.”](#)



Note

Unless otherwise specified, “ONS 15454” refers to both ANSI and ETSI shelf assemblies.

Before You Begin

This section lists the chapter procedures (NTPs). Turn to a procedure for applicable tasks (DLPs).

1. [NTP-G51 Verify DWDM Node Turn-Up, page 6-2](#)—Complete this procedure before beginning network turn-up.
2. [NTP-G52 Verify Node-to-Node Connections, page 6-3](#)—Complete this procedure next.
3. [NTP-G53 Set Up Timing, page 6-4](#)—Complete this procedure next.
4. [NTP-G54 Provision and Verify a DWDM Network, page 6-10](#)—Complete this procedure next.
5. [NTP-G56 Verify the OSNR, page 6-14](#)—Complete as needed.
6. [NTP-G142 Perform a Protection Switch Test, page 6-15](#)—Complete as needed.
7. [NTP-G57 Create a Logical Network Map, page 6-18](#)—Complete as needed.

NTP-G51 Verify DWDM Node Turn-Up

Purpose	This procedure verifies that each ONS 15454 is ready for DWDM network turn-up before adding nodes to a network. This procedure applies to all ROADM, OADM, and line amplifier nodes.
Tools/Equipment	Network plan provided by your network administrator
Prerequisite Procedures	Chapter 3, “Turn Up a Node”
Required/As Needed	Required
Onsite/Remote	Onsite or remote
Security Level	Provisioning or higher

-
- Step 1** Log into an ONS 15454 node on the network that you will test. See the [“DLP-G46 Log into CTC” task on page 2-25](#). If you are already logged in, proceed to Step 2.
- Step 2** Click the **Alarms** tab.
- Verify that the alarm filter is not turned on. See the [“DLP-G128 Disable Alarm Filtering” task on page 8-28](#) as necessary.
 - Verify that no equipment alarms appear (EQPT in the Alarms tab Cond column) indicating equipment failure or other hardware problems. If equipment failure alarms appear, investigate and resolve them before continuing. Refer to the *Cisco ONS 15454 DWDM Troubleshooting Guide* for procedures.
- Step 3** Verify that the software version shown in the node view (single-shelf mode) or multishelf view (multishelf mode) status area matches the version required by your network. (The status area is located to the left of the shelf graphic.) If the software is not the correct version, perform one of the following procedures:
- Perform a software upgrade using a Cisco ONS 15454 software CD. Refer to the release-specific software upgrade document.
 - Replace the TCC2/TCC2P cards with cards containing the correct release.
- Step 4** Click the **Provisioning > General** tabs. Verify that all general node information settings are correct according to documentation provided by the network administrator. If not, see the [“NTP-G80 Change Node Management Information” procedure on page 10-6](#).
- Step 5** Click the **Provisioning > Network** tabs. Ensure that the IP settings and other Cisco Transport Controller (CTC) network access information is correct according to documentation provided by the network administrator. If not, see the [“NTP-G81 Change CTC Network Access” procedure on page 10-18](#).
- Step 6** Click the **Provisioning > Protection** tabs. Verify that all required protection groups have been created according to documentation provided by the network administrator. If not, see the [“NTP-G33 Create a Y-Cable Protection Group” procedure on page 5-14](#) or the [“NTP-G83 Modify or Delete Card Protection Settings” procedure on page 10-34](#).
- Step 7** Click the **Provisioning > Security** tabs. Verify that all users have been created and that their security levels are correct according to documentation provided by the network administrator. If not, see the [“NTP-G88 Modify Users and Change Security” procedure on page 10-48](#).
- Step 8** If Simple Network Management Protocol (SNMP) is provisioned on the node, click the **Provisioning > SNMP** tabs. Verify that all SNMP settings are correct according to documentation provided by the network administrator. If not, see the [“NTP-G89 Change SNMP Settings” procedure on page 10-64](#).
- Step 9** Repeat this procedure at each node in the network.

Stop. You have completed this procedure.

NTP-G52 Verify Node-to-Node Connections

Purpose	This procedure verifies optical service channel (OSC) terminations between nodes and checks span attenuation. This procedure applies to all ROADMs, OADM, and line amplifier locations.
Tools/Equipment	None
Prerequisite Procedures	NTP-G51 Verify DWDM Node Turn-Up, page 6-2
Required/As Needed	Required
Onsite/Remote	Onsite or remote
Security Level	Provisioning or higher

- Step 1** Check to see if the fibers coming from the adjacent nodes are connected to the OPT-BST, OPT-BST-E, or OSC-CSM LINE RX and TX ports. If yes, continue with [Step 2](#). If not, do not continue. Install the cabling to the adjacent nodes using the “[NTP-G34 Install Fiber-Optic Cables on DWDM Cards and DCUs](#)” procedure on page 3-56.
- Step 2** Verify the following network fiber connections:
- The node’s west-side ports (LINE TX and RX) are connected to the east-side ports (LINE RX and TX) of the adjacent node.
 - The node’s east-side ports (LINE RX and TX) are connected to the west-side ports (LINE TX and RX) of the adjacent node.
- Step 3** Complete the “[DLP-G46 Log into CTC](#)” task on page 2-25 at the network node that you want to verify.
- Step 4** Click the **Provisioning > Comm Channels > OSC** tabs. Verify that OSC terminations appear under the OSC Terminations area for the east and west OSC-CSM or OSCM cards and that the port state is In-Service and Normal (IS-NR [ANSI]/Unlocked-enabled [ETSI]). If so, continue with [Step 5](#). If OSC terminations are not created, complete the “[NTP-G38 Provision OSC Terminations](#)” procedure on page 3-83.
- Step 5** Complete the “[NTP-G76 Verify Optical Span Loss Using CTC](#)” procedure on page 10-2 for all OSC-CSM cards. If the measured span loss is within the minimum and maximum expected span loss values, continue with [Step 6](#). If not, clean the fiber connected to the OPT-BST, OPT-BST-E, or OSC-CSM cards on both ends of the span, then repeat the “[NTP-G76 Verify Optical Span Loss Using CTC](#)” task on page 10-2. If the span loss is within the minimum and maximum expected span loss values, continue with [Step 6](#). If not, contact your next level of support.
- Step 6** Repeat Steps 2 through 5 at each network node.

Stop. You have completed this procedure.

NTP-G53 Set Up Timing

Purpose	This procedure provisions the ONS 15454 timing.
Tools/Equipment	None
Prerequisite Procedures	NTP-G51 Verify DWDM Node Turn-Up, page 6-2
Required/As Needed	Required
Onsite/Remote	Onsite or remote
Security Level	Provisioning or higher

-
- Step 1** Complete the “[DLP-G46 Log into CTC](#)” task on page 2-25 at the node where you will set up timing. If you are already logged in, continue with [Step 2](#).
- Step 2** Complete the “[DLP-G95 Set Up External or Line Timing](#)” task on page 6-4 if an external building integrated timing supply (BITS) source is available. This is the common ONS 15454 timing setup procedure.
- Step 3** If an external BITS source is not available, complete the “[DLP-G96 Set Up Internal Timing](#)” task on page 6-7. This task can only provide Stratum 3 timing.
- Step 4** Repeat this procedure at each node in the network.
- Stop. You have completed this procedure.**
-

DLP-G95 Set Up External or Line Timing

Purpose	This task defines the ONS 15454 timing source (external or line).
Tools/Equipment	None
Prerequisite Procedures	DLP-G46 Log into CTC, page 2-25
Required/As Needed	Required
Onsite/Remote	Onsite or remote
Security Level	Provisioning or higher

-
- Step 1** In node view (single-node mode) or shelf view (multishelf mode), click the **Provisioning > Timing > General** tabs.
- Step 2** In the General Timing area, complete the following information:
- Timing Mode—Choose **External** if the ONS 15454 derives its timing from a building integrated timing supply (BITS) source wired to the backplane pins (ANSI) or a MIC-C/T/P front mount electrical connection (FMEC) (ETSI); choose **Line** if timing is derived from an OSC-CSM or OSCM card that is optically connected to the timing node. A third option, Mixed, allows you to set external and line timing references.



Note Because Mixed timing might cause timing loops, Cisco does not recommend its use. Use this mode with care.

- SSM Message Set—For DWDM nodes, choose the Generation 2 synchronization status messaging (SSM) option. Generation 1 is used only by SONET or SDH ONS 15454s that are connected to equipment that does not support Generation 2. See the “Timing Reference” chapter in the *Cisco ONS 15454 DWDM Reference Manual* for more information about SSM, including definitions of the SONET timing levels.
- Quality of RES—Sets the timing quality for the user-defined, reserved (RES) S1 byte if your timing sources supports RES. Most timing sources do not use RES. If it does not support RES, choose RES=DUS (do not use for timing reference). Qualities are displayed in descending quality order as ranges. For example, in Generation 1 SSM, ST3<RES<ST2 means that the timing reference RES is higher than a Stratum 3 (ST3) and lower than a Stratum 2 (ST2).
- Revertive—Select this check box if you want the ONS 15454 to revert to a primary reference source after the conditions that caused it to switch to a secondary timing reference are corrected.
- Reversion Time—If Revertive is checked, choose the amount of time that the ONS 15454 will wait before reverting to its primary timing source. Five minutes is the default.

Step 3 In the Reference Lists area, complete the following information:



Note

You can define up to three timing references for the node and up to six BITS Out references. BITS Out references define the timing references used by equipment that can be attached to the node’s BITS Out pins on the backplane (ANSI) or FMEC (ETSI). If you attach equipment to BITS Out pins, you normally attach it to a node with Line mode, because equipment near the external timing reference can be directly wired to the reference.

- NE Reference—Allows you to define three timing references (Ref 1, Ref 2, Ref 3). The node uses Reference 1 unless a failure occurs to that reference, in which case the node uses Reference 2. If Reference 2 fails, the node uses Reference 3, which is typically set to Internal Clock. Reference 3 is the Stratum 3 clock provided on the TCC2/TCC2P card. The options displayed depend on the Timing Mode setting.
 - If the Timing Mode is set to External, your options are BITS-1, BITS-2, and Internal Clock.
 - If the Timing Mode is set to Line, your options are the node’s working OSCM cards, OSC-CSM cards, transponder (TXP) cards, muxponder (MXP) cards, and Internal Clock. Choose the cards/ports that are directly or indirectly connected to the node wired to the BITS source. Set Reference 1 to the card that is closest to the BITS source. For example, if Slot 5 is connected to the node wired to the BITS source, choose Slot 5 as Reference 1.
 - If the Timing Mode is set to Mixed, both BITS references and OSC, TXP, or MXP cards are available, allowing you to set a mixture of external BITS clocks and OSC, TXP, or MXP cards as timing references.
- BITS-1 Out/BITS-2 Out—Sets the timing references for equipment wired to the BITS Out backplane (ANSI) or FMEC (ETSI) pins. BITS-1 Out and BITS-2 Out are enabled when BITS-1 Out and BITS-2 Out facilities are put in service. If Timing Mode is set to external, choose the OSC, TXP, or MXP card used to set the timing. If Timing Mode is set to Line, you can choose an OSC, TXP, or MXP card or choose NE Reference to have the BITS-1 Out and/or BITS-2 Out follow the same timing references as the network element (NE).



Note

All TXP or MXP card client ports are available for timing regardless of the card’s termination mode. TXP or MXP trunk ports can be a timing reference when ITU-T G.709 is set to OFF and the Termination Mode is set to LINE.

Step 4 Click **Apply**.

Step 5 Click the **BITS Facilities** tab.



Note The BITS Facilities section sets the parameters for your BITS-1 and BITS-2 timing references. Many of these settings are determined by the timing source manufacturer. If equipment is timed through BITS Out, you can set timing parameters to meet the requirements of the equipment.

Step 6 In the BITS In area, complete the following information:

- Facility Type—(TCC2P card only) Choose the BITS signal type supported by your BITS clock, either DS1 or 64Khz+8Khz.
- BITS In State—If Timing Mode is set to External or Mixed, set the BITS In State for BITS-1 and/or BITS-2 to **IS** (in service) depending whether one or both BITS input pin pairs on the MIC are connected to the external timing source. If Timing Mode is set to Line, set the BITS In State to **OOS** (out of service).

Step 7 If BITS In State is set to OOS, continue with [Step 8](#). If the BITS In State is set to IS, complete the following information:

- Coding—Choose the coding used by your BITS reference, either B8ZS (binary 8-zero substitution) or AMI (alternate mark inversion).
- Framing—Choose the framing used by your BITS reference, either ESF (Extended Super Frame) or SF (D4) (Super Frame).
- Sync Messaging—Check this check box to enable SSM. SSM is not available if Framing is set to Super Frame.
- Admin SSM—If the Sync Messaging check box is not checked, you can choose the SSM Generation 2 type from the drop-down list. Choices are PRS (Primary reference source; Stratum 1), ST2 (Stratum 2), TNC (Transit Node Clock), ST3E (Stratum 3E), ST3 (Stratum 3), SMC (SONET minimum clock), and ST4 (Stratum 4).

Step 8 In the BITS Out area, complete the following information, as needed:

- Facility Type—(TCC2P only) Choose the BITS Out signal type, either DS1 or 64Khz+8Khz.
- BITS Out State—If equipment is connected to the node's BITS output pins on the backplane and you want to time the equipment from a node reference, set the BITS Out State for BITS-1 and/or BITS-2 to **IS**, depending on which BITS Out pins are used for the external equipment. If equipment is not attached to the BITS output pins, set the BITS Out State to **OOS**.

Step 9 If the BITS Out State is set to OOS, continue with [Step 10](#). If BITS Out State is set to IS, complete the following information:

- Coding—Choose the coding used by your BITS reference, either B8ZS or AMI.
- Framing—Choose the framing used by your BITS reference, either ESF or SF (D4).
- AIS Threshold—If SSM is disabled or Super Frame is used, choose the quality level where a node sends an alarm indication signal (AIS) from the BITS 1 Out and BITS 2 Out backplane pins. An AIS alarm is raised when the optical source for the BITS reference falls to or below the SSM quality level defined in this field.
- LBO—If an external device is connected to the BITS Out pins, sets the line build-out (LBO) distance between the ONS 15454 and an external device. If an external device is connected to BITS Out, choose the distance between the device and the ONS 15454. Options are: 0-133 ft. (default), 134-266 ft., 267-399 ft., 400-533 ft., and 534-655 ft. Line build out (LBO) relates to the BITS cable length. If an external device is not connected to BITS Out, leave this field set to the default.

Step 10 Click **Apply**.



Note Refer to the *Cisco ONS 15454 DWDM Troubleshooting Guide* for timing-related alarms.

Step 11 Return to your originating procedure (NTP).

DLP-G96 Set Up Internal Timing

Purpose	This task sets up internal timing (Stratum 3) for an ONS 15454.
Tools/Equipment	None
Prerequisite Procedures	DLP-G46 Log into CTC, page 2-25
Required/As Needed	As needed (use only if a BITS source is not available)
Onsite/Remote	Onsite or remote
Security Level	Provisioning or higher



Caution

Internal timing is Stratum 3 and is not intended for permanent use. All ONS 15454 SONET or SDH nodes should be timed to a Stratum 2 or better primary reference source. Internal timing is appropriate for DWDM nodes.

- Step 1** In node view (single-node mode) or shelf view (multishelf mode), click the **Provisioning > Timing > General** tabs.
- Step 2** In the General Timing area, enter the following:
- Timing Mode—Set to **External**.
 - SSM Message Set—Set to **Generation 1**.
 - Quality of RES—Does not apply to internal timing.
 - Revertive—Does not apply to internal timing.
 - Reversion Time—Does not apply to internal timing.
- Step 3** In the Reference Lists area, enter the following information:
- NE Reference
 - Ref 1—Set to **Internal Clock**.
 - Ref 2—Set to **Internal Clock**.
 - Ref 3—Set to **Internal Clock**.
 - BITS-1 Out/BITS-2 Out—Set to **None**.
- Step 4** Click **Apply**.
- Step 5** Click the **BITS Facilities** tab.
- Step 6** In the BITS Facilities area, change the BITS In State and BITS Out State to **OOS** for BITS 1 and BITS 2. Disregard the other BITS Facilities settings; they are not relevant to internal timing.
- Step 7** Click **Apply**.

Step 8 Return to your originating procedure (NTP).

DLP-G350 Use the Cisco MetroPlanner Traffic Matrix Report

Purpose	This task describes how to use the Cisco MetroPlanner traffic matrix report to provision and verify a DWDM network.
Tools/Equipment	None
Prerequisite Procedures	NTP-G139 Verify Cisco MetroPlanner Reports and Files, page 3-3
Required/As Needed	As needed
Onsite/Remote	Onsite
Security Level	Provisioning or higher

Step 1 Display a printed copy of the Cisco MetroPlanner Traffic Matrix report for your network. [Figure 6-1](#) shows an example of the Traffic Matrix report in Cisco MetroPlanner. The report can be exported in Microsoft Excel (XLS) or HTML format.

Figure 6-1 Cisco MetroPlanner Traffic Matrix Report

Service Demand	Service Circuit	OCH-CC Src	OCH-CC Src Position	OCH-CC Src Unit	OCH-CC Src Port	A/D Src Position	A/D Src Unit	A/D Src
Site1 - Site3_1	Site1 - Site3_1_1	Site3.E	Rack 1.ShelfAnsi 1.Slot 14	TXP_MR_10E_C	Client-RX	Rack 1.ShelfAnsi 1.Slot 16	AD-2C-S8.1	AD_RX0
		Site1.W	Rack 1.ShelfAnsi 1.Slot 15	TXP_MR_10E_C	Client-RX	Rack 1.ShelfAnsi 1.Slot 2	AD-2C-S8.1	AD_RX0
Site1 - Site3_2	Site1 - Site3_2_1	Site3.E	Rack 1.ShelfAnsi 1.Slot 13	TXP_MR_10E_C	Client-RX	Rack 1.ShelfAnsi 1.Slot 16	AD-2C-S8.1	AD_RX1
		Site1.W	Rack 1.ShelfAnsi 1.Slot 14	TXP_MR_10E_C	Client-RX	Rack 1.ShelfAnsi 1.Slot 2	AD-2C-S8.1	AD_RX1
Site1 - Site2_1	Site1 - Site2_1_1	Site1.E	Rack 1.ShelfAnsi 1.Slot 13	MXP_2.5G_10E_C	Client1-RX	Rack 1.ShelfAnsi 1.Slot 16	AD-4C-S8.1	AD_RX0
	Site2.W	Rack 1.ShelfAnsi 1.Slot 15	MXP_2.5G_10E_C	Client1-RX	Rack 1.ShelfAnsi 1.Slot 2	AD-4C-S8.1	AD_RX0	AD_RX0
	Site1 - Site2_1_2	Site1.E	Rack 1.ShelfAnsi 1.Slot 13	MXP_2.5G_10E_C	Client2-RX	Rack 1.ShelfAnsi 1.Slot 16	AD-4C-S8.1	AD_RX0
	Site2.W	Rack 1.ShelfAnsi 1.Slot 15	MXP_2.5G_10E_C	Client2-RX	Rack 1.ShelfAnsi 1.Slot 2	AD-4C-S8.1	AD_RX0	AD_RX0
	Site1 - Site2_1_3	Site1.E	Rack 1.ShelfAnsi 1.Slot 13	MXP_2.5G_10E_C	Client3-RX	Rack 1.ShelfAnsi 1.Slot 16	AD-4C-S8.1	AD_RX0
	Site2.W	Rack 1.ShelfAnsi 1.Slot 15	MXP_2.5G_10E_C	Client3-RX	Rack 1.ShelfAnsi 1.Slot 2	AD-4C-S8.1	AD_RX0	AD_RX0
	Site1 - Site2_1_4	Site1.E	Rack 1.ShelfAnsi 1.Slot 13	MXP_2.5G_10E_C	Client4-RX	Rack 1.ShelfAnsi 1.Slot 16	AD-4C-S8.1	AD_RX0
	Site2.W	Rack 1.ShelfAnsi 1.Slot 15	MXP_2.5G_10E_C	Client4-RX	Rack 1.ShelfAnsi 1.Slot 2	AD-4C-S8.1	AD_RX0	AD_RX0
Site2 - Site3_1	Site2 - Site3_1_1	Site2.E	Rack 1.ShelfAnsi 1.Slot 14	MXP_MR_10DME_C	Client1-RX	Rack 1.ShelfAnsi 1.Slot 16	AD-4C-S8.1	AD_RX0
	Site3.W	Rack 1.ShelfAnsi 1.Slot 15	MXP_MR_10DME_C	Client1-RX	Rack 1.ShelfAnsi 1.Slot 2	AD-4C-S8.1	AD_RX0	AD_RX0
	Site2 - Site3_1_2	Site2.E	Rack 1.ShelfAnsi 1.Slot 14	MXP_MR_10DME_C	Client2-RX	Rack 1.ShelfAnsi 1.Slot 16	AD-4C-S8.1	AD_RX0
	Site3.W	Rack 1.ShelfAnsi 1.Slot 15	MXP_MR_10DME_C	Client2-RX	Rack 1.ShelfAnsi 1.Slot 2	AD-4C-S8.1	AD_RX0	AD_RX0
	Site2 - Site3_1_3	Site2.E	Rack 1.ShelfAnsi 1.Slot 14	MXP_MR_10DME_C	Client3-RX	Rack 1.ShelfAnsi 1.Slot 16	AD-4C-S8.1	AD_RX0
	Site3.W	Rack 1.ShelfAnsi 1.Slot 15	MXP_MR_10DME_C	Client3-RX	Rack 1.ShelfAnsi 1.Slot 2	AD-4C-S8.1	AD_RX0	AD_RX0
	Site2 - Site3_1_4	Site2.E	Rack 1.ShelfAnsi 1.Slot 14	MXP_MR_10DME_C	Client4-RX	Rack 1.ShelfAnsi 1.Slot 16	AD-4C-S8.1	AD_RX0
	Site3.W	Rack 1.ShelfAnsi 1.Slot 15	MXP_MR_10DME_C	Client4-RX	Rack 1.ShelfAnsi 1.Slot 2	AD-4C-S8.1	AD_RX0	AD_RX0
	Site2 - Site3_1_5	Site2.E	Rack 1.ShelfAnsi 1.Slot 14	MXP_MR_10DME_C	Client5-RX	Rack 1.ShelfAnsi 1.Slot 16	AD-4C-S8.1	AD_RX0
	Site3.W	Rack 1.ShelfAnsi 1.Slot 15	MXP_MR_10DME_C	Client5-RX	Rack 1.ShelfAnsi 1.Slot 2	AD-4C-S8.1	AD_RX0	AD_RX0
	Site2 - Site3_1_6	Site2.E	Rack 1.ShelfAnsi 1.Slot 14	MXP_MR_10DME_C	Client6-RX	Rack 1.ShelfAnsi 1.Slot 16	AD-4C-S8.1	AD_RX0
	Site3.W	Rack 1.ShelfAnsi 1.Slot 15	MXP_MR_10DME_C	Client6-RX	Rack 1.ShelfAnsi 1.Slot 2	AD-4C-S8.1	AD_RX0	AD_RX0

Step 2 View the following information:

- Service Demand—Lists the general service demand from site to site.
- Service Circuit—Lists the service circuit.
- OCH-CC Src—Lists the optical channel client connection (OCHCC) source site and shelf direction, either east (E) or west (W).

- OCH-CC Src Position—Lists the OCHCC source rack, shelf, and slot.
- OCH-CC Src Unit—Lists the OCHCC source TXP, MXP, or ITU-T line card.
- OCH-CC Src Port—Lists the OCHCC source port.
- A/D Src Position—Lists the optical channel add/drop card source rack, shelf, and slot.
- A/D Src Unit—Lists the optical channel add/drop card source TXP, MXP, or ITU-T line card.
- A/D Src Port—Lists the optical channel add/drop card source port.
- OCH-CC Dst—Lists the optical channel client connection (OCHCC) destination site and shelf direction, either east (E) or west (W).
- OCH-CC Dst Position—Lists the OCHCC destination rack, shelf, and slot.
- OCH-CC Dst Unit—Lists the OCHCC destination TXP, MXP, or ITU-T line card.
- OCH-CC Dst Port—Lists the OCHCC destination port.
- A/D Dst Position—Lists the optical channel add/drop card destination rack, shelf, and slot
- A/D Dst Unit—Lists the optical channel add/drop card destination TXP, MXP, or ITU-T line card.
- A/D Dst Port—Lists the optical channel add/drop card destination port.
 - Dest Unit is the product ID of the optical path source card.
 - Dest Port is the port label reported on the front panel of the optical path destination card.
- Cl Service Type—identifies the service type of the optical channel.
- Protection—identifies the type of protection used for the optical channel:
 - Optical paths for unprotected-east and unprotected-west optical channels are routed along one direction only in the network.
 - Optical paths for Y-cable, fiber-switched, and client 1+1 optical channels are routed along two independent directions in the network.
- Op Bypass Site Name—identifies where the optical channel is dropped and reinserted when it is not terminated on a TXP or MXP card (optical bypass).



Note If the word None appears in the Op Bypass Site Name column, no optical bypass is defined for the optical channel.

- Wavelength—identifies the wavelength used for the optical channel. [Table 7-2 on page 7-12](#) lists the thirty-two available wavelengths.
- DWDM Interface Type—identifies the DWDM interface type that is used for the optical channel:
 - Transponder indicates that an MSTP transponder, an MSTP muxponder, or a DWDM pluggable port module is used for the optical channel.
 - Line Card indicates that an ITU line card is used for the optical channel.
- DWDM Card Type—identifies the type of TXP or line card that is used for the optical channel. For information about DWDM card types supported by Cisco MetroPlanner, refer to the *Cisco MetroPlanner DWDM Operations Guide*.

Step 3 Return to your originating procedure (NTP).

NTP-G54 Provision and Verify a DWDM Network

Purpose	This procedure verifies the performance of all cable connections and cards in a network topology. You can also use this procedure to troubleshoot any problems with DWDM network setup.
Tools/Equipment	Test set or protocol analyzer Cisco MetroPlanner Traffic Matrix
Prerequisite Procedures	DLP-G277 Provision a Multirate PPM, page 5-6 DLP-G278 Provision the Optical Line Rate, page 5-9 NTP-G96 Provision the 10G Multirate Transponder Card Line Settings, PM Parameters, and Thresholds, page 5-37 NTP-G97 Modify the 4x2.5G Muxponder Card Line Settings and PM Parameter Thresholds, page 5-58 NTP-G98 Provision the 2.5G Multirate Transponder Card Line Settings and PM Parameter Thresholds, page 5-17 NTP-G99 Modify the 2.5G Data Muxponder Card Line Settings and PM Parameter Thresholds, page 5-79 NTP-G148 Modify the 10G Data Muxponder Card Line Settings and PM Parameter Thresholds, page 5-97
Required/As Needed	As needed
Onsite/Remote	Onsite or remote
Security Level	Provisioning or higher

-
- Step 1** Complete the [“DLP-G46 Log into CTC” task on page 2-25](#) to log into an ONS 15454 on the network.
- Step 2** Click the **Alarms** tab:
- Verify that the alarm filter is not turned on. See the [“DLP-G128 Disable Alarm Filtering” task on page 8-28](#) as necessary.
 - Verify that no equipment (EQPT) alarms appear. If equipment failure alarms appear, investigate and resolve them before continuing. Refer to the *Cisco ONS 15454 DWDM Troubleshooting Guide* for procedures.
- Step 3** Using the Cisco MetroPlanner Traffic Matrix (see [Table 3-1 on page 3-3](#)) for your site, identify the first channel (ITU wavelength) to be provisioned. Use the TXP, MXP, or line card that corresponds to the selected wavelength.
- Step 4** For the ITU wavelength identified in [Step 3](#), create an OCHCC or OCHNC circuit using one of the following procedures:
- For OCHCCs, complete the [“DLP-G346 Provision Optical Channel Client Connections” procedure on page 7-4](#).
 - For OCHNCs, complete the [“DLP-G105 Provision Optical Channel Network Connections” procedure on page 7-11](#).

After completing the OCHCC or OCHNC circuit, return to this procedure and continue with [Step 5](#).

**Note**

Every time a channel is created in the DWDM network, the amplifiers automatically calculate the optical output power needed to maintain a constant power level on each channel. Automatic power control (APC) also starts every 60 minutes. If the span length changes, APC modifies amplifier gains and express variable optical attenuation (VOA). For more information about APC, refer to the “Network Reference” chapter in the *Cisco ONS 15454 DWDM Reference Manual*.

- Step 5** In node view (single-shelf mode) or multishelf view (multishelf mode), click the **Circuits** tab. Verify that the OCHCC or OCHNC created in [Step 4](#) has a DISCOVERED status and an IS state. If so, continue with [Step 6](#).
- Step 6** Click the circuit and click **Edit**.
- Step 7** In the Edit Circuit dialog box, click the **State** tab.
- Step 8** In the Cross-Connections table, record all the nodes that appear in the Node column. These are the nodes that are in the circuit path. The first node is the circuit source, and the last node is the circuit destination.
- Step 9** Display the circuit source node in node view (single-shelf mode), or shelf view (multishelf mode). If an OPT-PRE card is installed, complete the following steps. If not, continue with [Step 10](#).
- Display the OPT-PRE card in card view.
 - Click the **Provisioning > Opt.Ampli.Line > Parameters** tabs.
 - Check the value of the Port 2 (COM-TX) Signal Output Power:
 - If the OPT-PRE card is not carrying traffic, the values will not match. Skip this step and go to [Step 10](#).
 - If the value is equal to or greater than the value shown in the Channel Power Ref table cell, continue with [Step d](#).
 - If the value is lower than the value shown in the Channel Power Ref table cell, contact your next level of support.
 - If a second OPT-PRE is installed, repeat Steps [a](#) through [c](#) for the second OPT-PRE card. If not, continue with [Step 10](#).
- Step 10** If an OPT-BST card is installed, complete the following steps. If not, continue with [Step 11](#).
- Display the OPT-BST card in card view.
 - Click the **Provisioning > Opt.Ampli.Line > Parameters** tabs.
 - check the value of the Port 6 (COM-TX) Signal Output Power:
 - If the OPT-BST card is not carrying traffic, the values will not match. Skip this step and go to [Step 11](#).
 - If the value is equal to or greater than the value shown in the Channel Power Ref table cell, continue with [Step d](#).
 - If the value is lower than the value shown in the Channel Power Ref table cell, contact your next level of support.
 - If a second OPT-BST is installed, repeat Steps [a](#) through [c](#) for the second OPT-BST card. If not, continue with [Step 11](#).
- Step 11** If the node is a ROADM with 32WSS and 32DMX or 32-DMX-O cards installed and the circuit is an Add/Drop circuit, complete the following steps. If not, continue with [Step 12](#).
- In node view (single-node mode) or multishelf view (multishelf mode) click the **Provisioning > WDM-ANS > Provisioning** tabs.

- b. In the Selector area, double-click the one of the following parameters:
 - 32DMX-0 card installed—**West Side > Rx > Power > Band x > Ch y Drop Power** where x = 1 through 8 and y = 1 through 32 for the band and channel carrying the circuit.
 - 32DMX card installed—**West Side > Rx > Power > Add&Drop Drop Power**
- c. Record the value located in the Value table cell on the right for one of the following:
 - West Side.Rx.Power.Band x .Ch y Drop Power (if a 32DMX-O card is installed)
 - West Side.Rx.Power.Add&Drop - Drop Power (if a 32DMX card is installed)

If the value is not present, skip this step and continue with Step [d](#).

- d. Display 32DMX card installed on the west side in card view.
- e. Click the **Provisioning > Optical Chn > Parameters** tabs.
- f. Locate the channel that carries the circuit and verify that the value in the Power column matches the value recorded in Step [c](#), +/- 2 dB. If so, continue with Step [g](#). If the value is lower, contact your next level of support.



Note Note If the 32DMX card is not carrying traffic, the values will not match and the above check must be skipped.

- g. In node view (single-node mode) or multishelf view (multishelf mode) click the **Provisioning > WDM-ANS > Provisioning** tabs.
- h. In the Selector area, click the **West Side > Tx > Power > Add&Drop - Output Power** parameters. Record the value under the Value column. If the value is not present, skip this check and move to step [i](#).
- i. Display the 32WSS card installed on the west side in card view.
- j. Click the **Provisioning > Optical Chn: Optical Connector x > Parameters** where x = the MPO connector (1 through 4) carrying 8 wavelengths.
- k. Locate the CHAN-TX port, 1 through 32, that corresponds to the circuit and verify that the value in the Power column matches the value recorded in step [e](#)., +/- 1 dB. If the value is lower, contact your next level of support.



Note Note If the 32WSS card is not carrying traffic, the values will not match and the above check must be skipped.

- l. Repeat steps from [b](#) through [k](#) for cards that are installed on the east side.
- m. Continue with [Step 13](#).

Step 12 If the node is a ROADM with 32WSS and 32DMX cards installed and the circuit is a Pass-Through circuit, complete the following steps. If not, continue with [Step 13](#).

- a. In node view (single-node mode) or multishelf view (multishelf mode), click the **Provisioning > WDM-ANS > Provisioning** tabs.
- b. In the Selector area, double-click the **West Side > TX > Power** parameters. Record the value in the Power.Add&Drop - Output Power Value column. If the value is not present, skip this check and continue with Step [c](#).
- c. Display the 32WSS card installed on the west side in card view.

- d. Click the **Provisioning > Optical Chn: Optical Connector x > Parameters** where x = the MPO connector (1 through 4) carrying 8 wavelengths.
- e. Locate the port (CHAN-TX) 33 through 64, that corresponds to the circuit and verify that the value in the Power column matches the value recorded in step [b.](#), +/- 1 dB. If the value is lower, contact your next level of support.



Note Note If the 32WSS card is not carrying traffic, the values will not match and the above check must be skipped.

- f. Repeat steps [a](#) through [e](#) or the cards installed on the east side of the node.

Step 13 Check the received power range:

- a. Navigate to the node where the first TXP, MXP, or line card is installed.
- b. Display the TXP, MXP, or line card in card view.
- c. Complete the “[DLP-G136 Clear Selected PM Counts](#)” task on page 9-7.
- d. Click the **Performance > Optics PM** tabs.
- e. Record the values shown in the RX Optical Pwr field.
- f. Click the **Provisioning > Optics Thresholds** tabs.
- g. Verify that the value in Step [e](#) falls between the values shown for the RX Power High and RX Power Low. If so, continue with [Step 14](#). If not, complete one of the following.
 - Power lower than range—Clean the trunk fiber at the patch panel and on the TXP or MXP. Repeat Steps [e](#) through [g](#). If the power is still too low, contact your next level of support.
 - Power higher than range—Add attenuation to the fiber and repeat Steps [e](#) through [g](#). If the power still does not fall within the range, contact your next level of support.

Step 14 Perform a short-term bit error rate (BER) test:

- a. Complete the “[DLP-G136 Clear Selected PM Counts](#)” task on page 9-7 for the TXP, MXP, or line card.
- b. Display the TXP, MXP, or line card in card view.
- c. Click the **Performance > Payload PM** tabs, or, if OTN is provisioned, the **Performance > OTN PM** tabs.
- d. Perform a short-term BER test using a test signal from a test set or protocol analyzer.
- e. Monitor the payload performance monitoring (PM) for at least 10 minutes for errors.



Note To see an accurate PM count, the BER test results must be consistent with the transmitted bit rate for at least 10 minutes.



Note For information about using a test set or protocol analyzer, refer to the test set or protocol analyzer user guide.

Step 15 Display the next node in the circuit path identified in [Step 8](#) in node view.

Step 16 Repeat Steps [9](#) through [14](#) for the node.

- Step 17** Repeat Steps 15 and 16 for all nodes on the circuit path identified in Step 8. Complete the steps for the circuit destination node last.
- Step 18** Switch to network view and click the **Circuits** tab.
- Step 19** Create a new OCHNC or OCHCC circuit for the next ITU wavelength listed in the Traffic Matrix report using one of the following procedures:
- [NTP-G151 Create and Delete Optical Channel Client Connections, page 7-2](#)
 - [NTP-G150 Upgrade Optical Channel Network Connections to Optical Channel Client Connections, page 7-15](#)
- Step 20** After the circuit status is DISCOVERED and its state is IS, click it and then click **Edit**.
- Step 21** In the Edit Circuit dialog box, click the **State** tab.
- Step 22** In the Cross-Connections table, record all the nodes that appear in the Node column. These are the nodes that are in the circuit path. The first node is the circuit source, and the last node is the circuit destination.
- Step 23** Complete Steps 9 through 14 for nodes in Step 22 that:
- Are not part of the circuit created in Step 4.
 - Are the circuit source or destination and the circuit created in Step 4 did not originate or terminate on the same side (west or east).

For all the remaining nodes, no further checks are needed.

- Step 24** Repeat Steps 9 through 23 for all OCHCC or OCHNC circuits listed in your Traffic Matrix report. If a node fails any test, verify the setup and configuration and then repeat the test. If the test fails again, refer to the next level of support.

After all tests are successfully completed and no alarms exist in the network, the network is ready for service.

Stop. You have completed this procedure.

NTP-G56 Verify the OSNR

Purpose	This procedure verifies the optical signal-to-noise ratio (OSNR). The OSNR is the ratio between the signal power level and the noise power level.
Tools/Equipment	Optical spectrum analyzer
Prerequisite Procedures	DLP-G46 Log into CTC, page 2-25
Required/As Needed	As needed
Onsite/Remote	Onsite
Security Level	Provisioning or higher

- Step 1** Complete the “[DLP-G46 Log into CTC](#)” task on page 2-25 at an ONS 15454 on the network.
- Step 2** Using an optical spectrum analyzer, check the received OSNR for each transmitted channel on both ends of the span. Identify the last OSC-CSM, OPT-PRE, or OPT-BST MON port that the channel passes through before it is dropped. If OPT-PRE cards are installed with an OPT-BST, OPT-BST-E, or OSC-CSM card, use the OPT-PRE MON port.



Note For OSNR values for each card class, refer to the “Card Reference” chapter in the *Cisco ONS 15454 DWDM Reference Manual*.

Step 3 If the OSNR is too low, check the following, depending on your node configuration:



Note The purpose of this step is not to improve the signal-to-noise ratio (SNR), but to match the per-channel power level within the RX port power range.

- Check the fiber connections between the OPT-BST, OPT-BST-E, or OSC-CSM card and the OPT-PRE amplifier. If needed, clean the connectors. See the “[NTP-G115 Clean Fiber Connectors](#)” procedure on page 13-25.
- On the near-end OPT-BST amplifier, check the equalization of the added channels at the monitor output.
- On the OPT-PRE amplifier, check the output power on both COM TX and DC TX ports.
- On the far-end OPT-PRE amplifier, check the amplifier gain tilt at the monitor output.

If the OSNR is still too low, contact your next level of support.

Step 4 Repeat Steps 2 and 3 for all traffic in the network.

Stop. You have completed this procedure.

NTP-G142 Perform a Protection Switch Test

Purpose	This procedure tests the optical path, client TXPs, MXPs, and Y-cable protection groups in your system for proper operation. The test signals can be generated by either the actual client device or a test set, whichever is available. Cisco recommends that you repeat this test at each node in the network where protection group traffic is dropped.
Tools/Equipment	A list of protection groups. This information is provided in the Cisco MetroPlanner Traffic Matrix. A test set or actual client device that provides the required payload for the circuits that are provisioned.
Prerequisite Procedures	None
Required/As Needed	As needed
Onsite/Remote	Onsite; personnel are required to be on site at each end of the circuit under test.
Security Level	Provisioning or higher

Step 1 Complete the “[DLP-G46 Log into CTC](#)” task on page 2-25 at an ONS 15454 on the network.

Step 2 Identify the Y-cable circuit to be tested by viewing the Traffic Matrix for your site. Locate the TXPs/MXPs in the ONS 15454 node that will be used for the protection group.

- Step 3** Verify that the Y-cable protection group is provisioned:
- In node view (single-node mode) or multishelf view (multishelf mode), click the **Provisioning > Protection** tabs.
 - In the Protect and Working areas, confirm that the correct TXPs/MXPs are in the Y-cable protection group by viewing the slot number and card type.
 - If the required protection group is not provisioned, stop and perform the “[NTP-G33 Create a Y-Cable Protection Group](#)” procedure on page 5-14. Otherwise continue with [Step 4](#).
- Step 4** Repeat [Step 3](#) for each Y-cable protection group at this node. When all protection groups are verified, proceed to [Step 5](#).
- Step 5** Physically connect the transmitter of the client or test set to either Port 10 or Port 12 of the Y-cable module protecting the circuit under test. (See [Table 3-3 on page 3-76](#) and [Table 3-4 on page 3-76](#).)
- Step 6** If you connected the transmitter to Port 10, connect the client or test set receiver to Port 5 on the Y-cable module. If not, connect the client or test set receiver to Port 11 of the Y-cable module.
- Step 7** At the far-end site for the circuit under test, physically loop the Y-cable module as follows:
- If this is the first client on the Y-cable module, loop Port 10 to Port 5 on the far-end Y-cable module.
 - If this is the second client on the Y-cable module, loop Ports 11 and 12 on the far-end Y-cable module.
- Step 8** At the near-end site for the circuit under test, place the client device or test set into service and begin transmitting the required payload.
- Step 9** In CTC, display the near-end site in node view (single-node mode) or multishelf view (multishelf mode).
- Step 10** Click the **Maintenance > Protection** tabs ([Figure 6-2](#)).

Figure 6-2 Maintenance > Protection Tabs

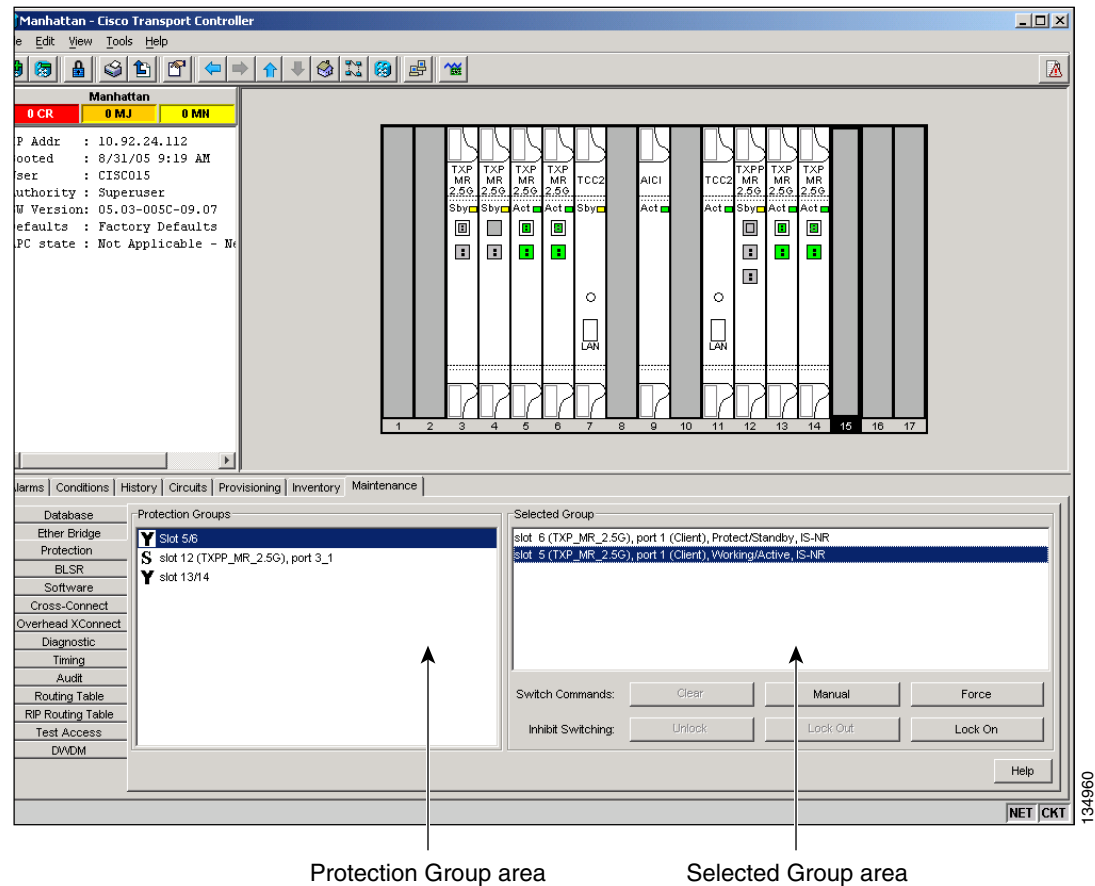

Protection Group area

Selected Group area

- Step 11** In the Protection Groups area, highlight the protection group to be tested.
- Step 12** In the Selected Group area, identify the slot that is Active and the slot that is Standby.
- Step 13** Verify that the LED display on the physical cards in the shelf match the following:
- For the Active TXP/MXP card, record the slot number: _____. Verify that the port LEDs are as follows:
 - DWDM port is green.
 - Client port is green.
 - For the Standby TXP/MXP card, record the slot number: _____. Verify that the port LEDs are as follows:
 - DWDM port is green.
 - Client port is not illuminated or amber, depending on the TXP/MXP card.
- Step 14** In the Selected Group area, highlight the active TXP/MXP slot.
- Step 15** From the Switch Commands area below the Selected Group area, click **Manual**, then click **YES**.
- Step 16** From the Selected Group area, record the following information and verify that the active and standby TXP/MXP slot numbers are the opposite of [Step 13](#).
- For the Active TXP/MXP card, record the slot number: _____. Verify that the port LEDs are as follows:

- DWDM port is green.
 - Client port is green.
- b.** For the Standby TXP/MXP card, record the slot number: _____. Verify that the port LEDs are as follows:
- DWDM port is green.
 - Client port is not illuminated or amber, depending on the TXP/MXP card.
- Step 17** Verify that the LED displays on the physical cards in the shelf match the following:
- a.** For the Active TXP/MXP slot LEDs:
- DWDM port is green.
 - Client port is green.
- b.** For the Standby TXP/MXP slot LEDs:
- DWDM port is green.
 - Client port is not illuminated.
- Step 18** Confirm that the client or test set at the local site is operating normally with no alarms. If the test set is reporting active alarms, contact your next level of support.
-  **Note** It is normal to see a traffic hit on the test set during a protection switch.
- Step 19** From the Switch Commands area below the Selected Group area, click **Clear**, then click **YES** to return the protection group to the original state.
- Step 20** Repeat Steps 5 through 19 for each protection group at your site.
- Stop. You have completed this procedure.**
-

NTP-G57 Create a Logical Network Map

Purpose	This procedure allows a Superuser to create a consistent network view for all nodes on the network.
Tools	None
Prerequisite Procedures	This procedure assumes that network turn-up is complete.
Required/As Needed	As needed
Onsite/Remote	Onsite or remote
Security Level	Superuser

- Step 1** Complete the “[DLP-G46 Log into CTC](#)” task on page 2-25 at a node on the network where you want to create the network map. If you are already logged in, continue with Step 2.
- Step 2** From the View menu, choose **Go to Network View**.
- Step 3** Change the position of the nodes in the network view according to your site plan.
- a.** Click a node to select it, then drag and drop the node icon to a new location.

b. Repeat Step a for each node you need to position.

Step 4 On the network view map, right-click and choose **Save Node Position** from the shortcut menu.

Step 5 Click **Yes** in the Save Node Position dialog box.

CTC opens a progress bar and saves the new node positions.



Note Retrieve, Provisioning, and Maintenance users can move nodes on the network map, but only Superusers can save new network map configurations. To restore the view to a previously saved version of the network map, right-click the network view map and choose **Reset Node Position**.

Stop. You have completed this procedure.



Create Channels and Circuits

This chapter explains how to create Cisco ONS 15454 dense wavelength division multiplexing (DWDM) optical channel client connections (OCHCCs), optical channel client network connections (OCHNCs), and overhead circuits. It also tells you how to upgrade OCHNCs to OCHCCs.



Note

Unless otherwise specified, “ONS 15454” refers to both ANSI and ETSI shelf assemblies.

Before You Begin

Before performing any of the following procedures, investigate all alarms and clear any trouble conditions. Refer to the *Cisco ONS 15454 DWDM Troubleshooting Guide* as necessary.

This section lists the chapter procedures (NTPs). Turn to a procedure for applicable tasks (DLPs).

1. [NTP-G151 Create and Delete Optical Channel Client Connections, page 7-2](#)—Complete as needed.
2. [NTP-G59 Create and Delete Optical Channel Network Connections, page 7-10](#)—Complete as needed.
3. [NTP-G150 Upgrade Optical Channel Network Connections to Optical Channel Client Connections, page 7-15](#)—Complete as needed.
4. [NTP-G60 Create and Delete Overhead Circuits, page 7-21](#)—Complete as needed to create IP-encapsulated, firewall, and proxy tunnels, to create generic communications channel (GCC) terminations, to provision orderwire, or to create user data channel (UDC) circuits.
5. [NTP-G62 Create a J0 Section Trace, page 7-29](#)—Complete as needed to monitor interruptions or changes to traffic between two nodes.
6. [NTP-G58 Locate and View Optical Channel Network and Client Connections, page 7-30](#)—Complete as needed to find, view, and filter OCHCCs and OCHNCs.

NTP-G151 Create and Delete Optical Channel Client Connections

Purpose	This procedure creates and deletes DWDM OCHCC circuits.
Tools/Equipment	None
Prerequisite Procedures	Chapter 3, “Turn Up a Node”
Required/As Needed	As needed
Onsite/Remote	Onsite or remote
Security Level	Provisioning or higher

-
- Step 1** As needed, identify the OCHCC to be provisioned using the [“DLP-G350 Use the Cisco MetroPlanner Traffic Matrix Report”](#) task on page 6-8.
- Step 2** Complete the [“DLP-G46 Log into CTC”](#) task on page 2-25 at a node on the network where you want to create and delete OCHCCs. If you are already logged in, continue with [Step 3](#).
- Step 3** If you want to assign a name to the OCHCC source and destination ports before you create the circuit, complete the [“DLP-G104 Assign a Name to a Port”](#) task on page 7-3. (Naming the client ports facilitates the OCHCC creation by helping you more quickly identify the correct client ports.) If not, continue with [Step 4](#).
- Step 4** If the client TXP/MXP/line cards are installed in a multishelf, continue with [Step 5](#). If not, complete the following steps:
- Use the information obtained from the Cisco MetroPlanner traffic matrix report in [Step 1](#) to complete the [“DLP-G344 Verify Provisionable Patchcords”](#) task on page 7-18. If PPCs are created between the nodes containing the TXP/MXP/ITU-T line cards and the DWDM nodes at each end of the OCHCC, continue with [Step 5](#). If not, continue with [Step b](#).
 - complete the [“DLP-G99 Create a Provisionable Patchcord”](#) task on page 7-20 to create the PPCs between the OCHCC source and destination nodes.
- Step 5** If the client TXP/MXP/ITU-T line card is installed in a multishelf, use the information obtained from the Cisco MetroPlanner traffic matrix report in [Step 1](#) to create internal patchcords between the 32DMX or 32DMX-O ports and the TXP/MXP trunk ports using the [“DLP-G354 Create an Internal Patchcord Manually”](#) task on page 3-81. Create the internal patchcords on both the source and destination nodes of each OCHCC path. If the TXP/MXP/ITU-T line card is not installed in a multishelf, continue with [Step 6](#).
- Step 6** Complete the [“DLP-G345 Verify OCHCC Client Ports”](#) task on page 7-3.
- Step 7** Complete the [“DLP-G346 Provision Optical Channel Client Connections”](#) task on page 7-4 as needed.
- Step 8** Complete the [“DLP-G347 Delete Optical Channel Client Connections”](#) task on page 7-8 as needed.
- Stop. You have completed this procedure.**
-

DLP-G104 Assign a Name to a Port

Purpose	This task assigns a name to a port on any ONS 15454 card.
Tools/Equipment	None
Prerequisite Procedures	DLP-G46 Log into CTC, page 2-25
Required/As Needed	As needed
Onsite/Remote	Onsite or remote
Security Level	Provisioning or higher

-
- Step 1** Double-click the card that has the port that you want to provision. This can be any port on a traffic-carrying card.
- Step 2** Click the **Provisioning** tab.
- Step 3** Double-click the **Port Name** table cell for the port number to which you are assigning a name. The cell activates and a blinking cursor appears to indicate where you are to type the port name.
- Step 4** Type the port name.
The port name can be up to 32 alphanumeric/special characters. The field is blank by default.
- Step 5** Click **Apply**.
- Step 6** Return to your originating procedure (NTP).
-

DLP-G345 Verify OCHCC Client Ports

Purpose	This task verifies the OCHCC client ports.
Tools/Equipment	DLP-G46 Log into CTC, page 2-25
Prerequisite Procedures	Chapter 3, “Turn Up a Node”
Required/As Needed	As needed
Onsite/Remote	Onsite
Security Level	Provisioning or higher

-
- Step 1** Display the TXP, MXP, or ITU-T line card in card view.
- Step 2** Click the **Provisioning > Maintenance** tabs.
- Step 3** Verify that the administrative state of the client and trunk ports is Out of Service and Disabled (OOS,DSBLD) (ANSI) or Locked,disabled (ETSI). If so, continue with [Step 4](#). If not, complete the following steps:
- Click the Admin State table cell and choose **OOS,DSBLD** (ANSI) or **Locked,disabled** (ETSI) for the client and trunk ports.
 - Click **Apply**.
- Step 4** Click the **Provisioning > Pluggable Port Modules** tabs.

- Step 5** Verify that a pluggable port module has been created and that the port rate under the Pluggable Port area is provisioned. If so, continue with [Step 7](#). If not, complete the “[DLP-G277 Provision a Multirate PPM](#)” task on page 5-6 and the “[DLP-G278 Provision the Optical Line Rate](#)” task on page 5-9.
- Step 6** Repeat Steps 1 through 5 for each TXP, MXP, or ITU-T line card containing OCHCC ports that you want to verify.
- Step 7** Return to your originating procedure (NTP).

DLP-G346 Provision Optical Channel Client Connections

Purpose	This task creates an OCHCC between two transponder (TXP), muxponder (MXP), or ITU-T-compliant OC card ports.
Tools/Equipment	Cisco MetroPlanner Traffic Matrix Report
Prerequisite Procedures	DLP-G46 Log into CTC, page 2-25 DLP-G345 Verify OCHCC Client Ports, page 7-3
Required/As Needed	As needed
Onsite/Remote	Onsite
Security Level	Provisioning or higher



Note OCHCCs can be created on preprovisioned client cards or physically installed client cards.



Note OCHCC creation will fail if the client card’s trunk port is in service and the trunk port parameters provisioned on the OCHCC circuit creation wizard differ from the settings provisioned on the client card’s trunk port. If you want the OCHCC circuit to provision the client card trunk port’s ITU-T G.709, FEC, SD and SF threshold settings and Mapping parameters, you must place the client card trunk ports out of service.



Note Creating an OCHCC circuit automatically creates an OCH trail circuit between the OCHCC source and destination client card trunk ports. The OCH trail circuit is created for the first OCHCC between two MXP cards. The OCH trail circuit is used by succeeding OCHCCs created between the MXP cards. When the OCH trail is created, it is assigned a system-generated name in the format *circuit-type_NE-name::unique sequence number*. To edit the OCH trail circuit name, complete the “[DLP-G425 Edit an OCH Trail Circuit Name](#)” task on page 7-10.



Note If trunk ports are connected by a peer-to-peer provisionable patchcord (PPC), an OCH trail is not created.



Note The OCH Wlen (wavelength) parameter on the Circuits page can be used to determine the OCHCC and OCH trail associations.

- Step 1** From the View menu, choose **Go to Network View**.

- Step 2** Click the **Circuits** tab, then click **Create**.
- Step 3** In the Circuit Creation dialog box, choose **OCHCC** from the Circuit Type list.
- Step 4** Click **Next**.
- Step 5** In the Circuit area of the Circuit Attributes page (Figure 7-1), provision the OCHCC circuit attributes:
- **Name**—Assign a name to the OCHCC. The name can be alphanumeric and up to 48 characters (including spaces). Circuit names should be 44 characters or less if you want the ability to create monitor circuits. If you leave the field blank, CTC assigns a default name to the circuit.
 - **Type**—(Display only) OCHCC.
 - **Size**—Defines the circuit payload type and rate. Two fields are provided. The first specifies the payload type. Choose a payload type, then choose the rate in the next field. Table 7-1 provides the OCHCC payload types and rates.



Note The payload type and rate must match the PPM provisioning on the client cards at the source and destination nodes.

Table 7-1 OCHCC Client Rates

Payload Type	Rates
SONET/SDH	ANSI/ETSI OC-192/STM-64—9.92 Gbps OC-48/STM-12—2.48 Gbps OC-12/STM-4—622 Mbps OC-3/STM-1—155 Mbps
Ethernet	10GE—One Gigabit Ethernet 11.25 Gbps 1GE—One Gigabit Ethernet 1.125 Gbps
FC/FICON	10GFC—Fibre Channel 10Gpbs 4GFC—Fibre Channel 4Gpbs 2GFC—Fibre Channel 2.125Gpbs 1GFC—Fibre Channel 1.06 Gpbs 4GFICON—FICON 4Gpbs 2GFICON—FICON 2.125 Gpbs 1GFICON—FICON 1.06 Gpbs
Data Storage	ESCON—Enterprise System Connection 200 Mbps (IBM signal) ISC Peer—InterSystem Coupling Link 3 (ISC3) ISC3 Peer 1G—InterSystem Coupling Link 3 (ISC3) 1 Gpbs ISC3 Peer 2G—InterSystem Coupling Link 3 (ISC3) 2 Gpbs ISC COMPAT—InterSystem Coupling Link 1 (ISC1)

Table 7-1 OCHCC Client Rates (continued)

Payload Type	Rates
Video	HDTV—High Definition Television SDI/DI—Serial Digital Interface and Digital Video signal type 1 DV6000—Proprietary signal from video vendor
Other	Pass Through—Creates a pass-through OCHCC

- OCHNC Wavelength—Provides three fields to define the wavelength that the OCHCC will use to travel across the OCH network. Choose a wavelength from the first field. In the second field, you can change the wavelength band by choosing either C Band or L Band. In the third field, you can indicate whether odd or even C-band or L-band wavelengths are displayed.



Note The OCHNC wavelength must match the trunk wavelength provisioned on the source and destination TXP or MXP cards. If the wavelengths do not match, the card will not appear as a source or destination.

- Bidirectional—(Display only) OCHCCs are bidirectional. This field cannot be changed.

Figure 7-1 OCHCC Attributes Page

- Step 6** In the State area of the Circuit Attributes page, provision the OCHCC state attributes:
- State—Provisions the OCHCC circuit state. The state can be IS (ANSI)/Unlocked (ETSI) or OOS,DSBLED (ANSI)/Locked,Disabled (ETSI).
 - Apply to OCHCC ports—If checked, applies the state chosen in the Apply to OCHCC ports drop-down list to the OCHCC client ports. For TXP, MXP, TXPP, or MXPP cards, this will be the client and all trunk ports. For ITU-T-compliant OC line cards, this will be the trunk port only. The states that you can apply include: IS (ANSI)/Unlocked (ETSI), OOS,DSBLED (ANSI)/Locked,Disabled (ETSI), and IS,AINS (ANSI)/Unlocked,AutomaticInService (ETSI).
- Step 7** In the Protection area of the Circuit Attributes page, provision the OCHCC protection attributes:

- Protection—Check this box if the source and destination client cards are TXPP or MXPP cards. Checking the box restricts the source and destination choices to those cards and allows you to provision the reversion parameters.
- Reversion—If Protection is checked, checking this box turns on the TXPP or MXPP reversion parameter.
- Reversion Time—If Reversion is checked, set the time before the protection will switch to the active port after conditions that caused the switch are remedied.

Step 8 In the Trunk area of the Circuit Attributes page, provision the OCHCC trunk attributes:



Note For information about the trunk fields supported by the TXP, MXP, or ITU-T line card, refer to the [Chapter 11, “Change DWDM Card Settings,”](#) and to the “Card Reference” chapter in the *ONS 15454 DWDM Reference Manual*.

- G.709 OTN—If checked, enables the ITU-T G.709 optical transport network on the client cards, if permitted by the client card and payload.
- FEC—Allows you to enable or disable FEC on the client cards, if permitted by the client card and payload.
- SF BER—Allows you to set the signal fail bit error rate for payloads and client cards that allow the parameter to be provisioned.
- SD BER—Allows you to set the signal degrade bit error rate for payloads and client cards that allow the parameter to be provisioned.
- Mapping—Sets the mapping for the TXP_MR_10E, TXP_MR_10E_C, TXP_MR_10E_L, MXP_MR_10DME_C, and MXP_MR_DME_L cards. If you set mapping to Synchronous, the client signal is mapped into the OTU2 signal without justification of the payload because the client signal timing (the timing source) is the same as the trunk output timing. If you set mapping to asynchronous, the trunk timing is disconnected from the client timing (because the network element [NE] is the timing source), so justification is needed to map the client signal (OC192/STM64) to OTU2 trunk output.

Step 9 Click **Next**.

Step 10 In the Source area, choose the source node from the Node drop-down list, then choose the source shelf (multishelf nodes only) slot and, if needed, source port from the Shelf, Slot and Port drop-down lists.

If no nodes appear in the Node drop-down list, complete the following steps:

- a. Click **Back** and review your circuit attribute settings. Verify that they are set to the client attributes provisioned on the client cards. If necessary, click **Cancel** and complete the [“DLP-G345 Verify OCHCC Client Ports”](#) task on page 7-3 to verify the client settings.
- b. If the source and/or destination nodes are not configured for multishelf, complete the [“DLP-G344 Verify Provisionable Patchcords”](#) task on page 7-18 to verify the patchcords were created accurately.

If these steps do not solve the problem, refer to your next level of support.

Step 11 Click **Next**.

Step 12 In the Destination area, choose the destination node from the Node drop-down list, then choose the destination shelf (multishelf nodes only), slot and, if needed, source port from the Shelf, Slot and Port drop-down lists.

If no nodes appear in the Node drop-down list, complete the following steps:

- a. Click **Back** and review your circuit attribute settings. Verify that they are set to the client attributes provisioned on the client cards. If necessary, click **Cancel** and complete the “[DLP-G345 Verify OCHCC Client Ports](#)” task on page 7-3 to verify the client settings.
- b. If the source and/or destination nodes are not configured for multishelf, complete the “[DLP-G344 Verify Provisionable Patchcords](#)” task on page 7-18 to verify the patchcords were created accurately.

If these steps do not solve the problem, refer to your next level of support.

- Step 13** Click **Finish**. The OCHCC and its OCH trail will appear in the Circuits window. After the circuit status has been verified, the DISCOVERED status appears in the Status column.

If the OCHCC status does not change to DISCOVERED within a 2-3 minutes, refer to the *ONS 15454 DWDM Troubleshooting Guide* for troubleshooting procedures.

- Step 14** Return to your originating procedure (NTP).

DLP-G347 Delete Optical Channel Client Connections

Purpose	This task deletes DWDM OCHCC circuits.
Tools/Equipment	None
Prerequisite Procedures	DLP-G46 Log into CTC, page 2-25
Required/As Needed	As needed
Onsite/Remote	Onsite or remote
Security Level	Provisioning or higher



Note

If you are deleting more than half of all the active OCHCCs, Cisco recommends that you delete them two at a time to allow for proper power compensation. This does not apply if you are deleting all the active OCHCCs.

- Step 1** Complete the “[NTP-G103 Back Up the Database](#)” procedure on page 13-2, or record the circuit information if it will be recreated.
- Step 2** Consult your network operations center (NOC) or other appropriate personnel to verify that the OCHCC can be safely deleted.
- Step 3** Investigate all network alarms and resolve any problems that might be affected by the OCHCC deletion.
- Step 4** Choose **View > Go to Network View**.
- Step 5** Click the **Circuits** tab.
- Step 6** Choose one or more OCHCCs, identified under the Type column, that you want to delete, then click **Delete**.
- Step 7** In the Delete Circuits confirmation dialog box, complete the following:
- Change drop port admin state—check this box if you want to change the circuit source and destination ports administrative state. After checking the box, choose one of the following administrative states:
 - IS (ANSI) or Unlocked (ETSI—puts the ports in service).

- IS,AINS (ANSI) or UnlockedAutomaticInService (ETSI)—puts the ports in automatic in service.
- OOS,DSBLD (ANSI) or Locked,disabled (ETSI)—removes the ports from service and disables them.
- OOS,MT (ANSI) or Locked,maintenance (ETSI)—removes the ports from service for maintenance.
- Notify when completed—If checked, the CTC Alerts confirmation dialog box indicates when the OCHCC is deleted. During this time, you cannot perform other CTC functions. If you are deleting many OCHCCs, waiting for confirmation might take a few minutes. Circuits are deleted whether or not this check box is checked.



Note The CTC Alerts dialog box will not automatically open to show a deletion error unless you checked All alerts or Error alerts only in the CTC Alerts dialog box. For more information, see the “[DLP-G53 Configure the CTC Alerts Dialog Box for Automatic Popup](#)” task on page 2-32. If the CTC Alerts dialog box is not set to open automatically with a notification, the red triangle inside the CTC Alerts toolbar icon indicates that a notification exists.

- Step 8** Complete one of the following:
- If you checked Notify when completed, the CTC Alerts dialog box appears. If you want to save the information, continue with [Step 10](#). If you do not want to save the information, continue with [Step 11](#).
 - If you did not check Notify when completed, the Circuits window appears. Continue with [Step 12](#).
- Step 9** If you want to save the information in the CTC Alerts dialog box, complete the following steps. If you do not want to save it, continue with [Step 11](#).
- a. Click **Save**.
 - b. Click **Browse** and navigate to the directory where you want to save the file.
 - c. Type the file name using a.txt file extension, and click **OK**.
- Step 10** Click **Close** to close the CTC Alerts dialog box.
- Step 11** Complete the “[NTP-G103 Back Up the Database](#)” procedure on page 13-2 if you require a backup of your changes.
- Step 12** Return to your originating procedure (NTP).

DLP-G424 Edit an OCHCC Circuit Name

Purpose	This task changes the name of an OCHCC circuit.
Tools/Equipment	None
Prerequisite Procedures	DLP-G105 Provision Optical Channel Network Connections , page 7-11 DLP-G46 Log into CTC , page 2-25
Required/As Needed	As needed
Onsite/Remote	Onsite or remote
Security Level	Provisioning or higher

-
- Step 1** From the View menu, choose **Go to Network View**.
- Step 2** Click the **Circuits** tab.
- Step 3** Click the OCHCC whose name you want to edit, then click **Edit**. The Edit Circuit dialog box appears with the General tab displayed.
- Step 4** In the Name field, enter the new OCHCC circuit name.
- Step 5** Click **Apply**.
- Step 6** Return to your originating procedure (NTP).
-

DLP-G425 Edit an OCH Trail Circuit Name

Purpose	This task changes the name of an OCH trail circuit.
Tools/Equipment	None
Prerequisite Procedures	DLP-G105 Provision Optical Channel Network Connections, page 7-11 DLP-G46 Log into CTC, page 2-25
Required/As Needed	As needed
Onsite/Remote	Onsite or remote
Security Level	Provisioning or higher

-
- Step 1** From the View menu, choose **Go to Network View**.
- Step 2** Click the **Circuits** tab.
- Step 3** Click the OCH trail whose name you want to edit, then click **Edit**. The Edit Circuit dialog box appears with the General tab displayed.
- Step 4** In the Name field, enter the new OCH trail circuit name.
- Step 5** Click **Apply**.
- Step 6** Return to your originating procedure (NTP).
-

NTP-G59 Create and Delete Optical Channel Network Connections

Purpose	This procedure creates and deletes DWDM OCHNC channels.
Tools/Equipment	None
Prerequisite Procedures	Chapter 3, “Turn Up a Node”
Required/As Needed	As needed
Onsite/Remote	Onsite or remote
Security Level	Provisioning or higher

-
- Step 1** Complete the “[DLP-G46 Log into CTC](#)” task on page 2-25 at a node on the network where you want to create and delete OCHNCs. If you are already logged in, continue with Step 2.
- Step 2** If you want to assign a name to the OCHNC source and destination ports before you create the circuit, complete the “[DLP-G104 Assign a Name to a Port](#)” task on page 7-3. If not, continue with the next step.
- Step 3** Complete the “[DLP-G105 Provision Optical Channel Network Connections](#)” task on page 7-11 as needed.
- Step 4** Complete the “[DLP-G106 Delete Optical Channel Network Connections](#)” task on page 7-13 as needed.
- Step 5** Complete the “[DLP-G426 Edit an OCHNC Circuit Name](#)” task on page 7-15, as needed.
- Stop. You have completed this procedure.**
-

DLP-G105 Provision Optical Channel Network Connections

Purpose	This task creates an OCHNC between ONS 15454s that are provisioned for DWDM.
Tools/Equipment	None
Prerequisite Procedures	<ul style="list-style-type: none"> • DLP-G46 Log into CTC, page 2-25 • An OCHNC add port on the source node and an OCHNC drop port on destination node of the same wavelength • Cisco MetroPlanner Traffic Matrix Report
Required/As Needed	As needed
Onsite/Remote	Onsite
Security Level	Provisioning or higher

- Step 1** Choose **View > Go to Network View**.
- Step 2** Click the **Circuits** tab, then click **Create**.
- Step 3** In the Circuit Creation dialog box, choose **OCHNC** from the Circuit Type list.
- Step 4** Click **Next**.
- Step 5** In the Circuit area of the Circuit Attributes, provision the OCHNC circuit attributes:
- **Name**—Assign a name to the OCHNC. The name can be alphanumeric and up to 48 characters (including spaces). Circuit names should be 44 characters or less if you want the ability to create monitor circuits. If you leave the field blank, CTC assigns a default name to the circuit.
 - **Type**—(Display only) OCHNC.
 - **Size**—Equipped non specific is the default. You cannot change it.
 - **OCHNC Wavelength**—Choose a band, either C Band or L Band in the lower drop-down list, then choose wavelength you want to provision in the upper drop-down list. [Table 7-2](#) lists the thirty-two available wavelengths.

Table 7-2 OCHNC Channels

Channel No.	Channel ID	Frequency (GHz)	Wavelength (nm)
1	30.3	195.9	1530.33
2	31.2	195.8	1531.12
3	31.9	195.7	1531.90
4	32.6	195.6	1532.68
5	34.2	195.4	1534.25
6	35.0	195.3	1535.04
7	35.8	195.2	1535.82
8	36.6	195.1	1536.61
9	38.1	194.9	1538.19
10	38.9	194.8	1538.98
11	39.7	194.7	1539.77
12	40.5	194.6	1540.56
13	42.1	194.4	1542.14
14	42.9	194.3	1542.94
15	43.7	194.2	1543.73
16	44.5	194.1	1544.53
17	46.1	193.9	1546.12
18	46.9	193.8	1546.92
19	47.7	193.7	1547.72
20	48.5	193.6	1548.51
21	50.1	193.4	1550.12
22	50.9	193.3	1550.92
23	51.7	193.2	1551.72
24	52.5	193.1	1552.52
25	54.1	192.9	1554.13
26	54.9	192.8	1544.94
27	55.7	192.7	1555.75
28	56.5	192.6	1556.55
29	58.1	192.4	1558.17
30	58.9	192.3	1558.98
31	59.7	192.2	1559.79
32	60.6	192.1	1560.61

- Use OCHNC Direction—Choose the OCHNC direction, either **East to West** or **West to East**. If you choose West to East, the channel will exit the node through the LINE-TX port of the east OSC-CSM, OPT-BST, or OPT-BST-E card, named the East Side Card by Cisco MetroPlanner (typically, these

cards are hosted by Slot 17). If you choose East to West, the channel will exit the node through the LINE-TX port of the west OSC-CSM, OPT-BST, or OPT-BST-E card, named the West Side Card by Cisco MetroPlanner (typically, these cards are hosted by Slot 1).



Note OCHNC direction is not used in Software Release 7.0.

- **Bidirectional**—Check this check box to create a bidirectional OCHNC; uncheck it to create a unidirectional OCHNC.
- **State**—Provisions the OCHNC circuit state. The state can be IS (ANSI)/Unlocked (ETSI) or OOS,DSBLED (ANSI)/Locked,Disabled (ETSI).

Step 6 Click **Next**.

Step 7 In the Circuit Source area, choose the source node from the Node drop-down list, then choose the source shelf (multishelf only), slot, and, if needed source port from the Shelf, Slot, and Port drop-down lists. The source In and Out shelf (multishelf only), slot and port appear under the OTS (optical transport signal) Lines area to show the OTS in and out shelf, slot, and ports.

Step 8 Click **Next**.

Step 9 In the Circuit Destination area, choose the destination node from the Node drop-down list, then choose the destination shelf (multishelf only), slot, and, if needed destination port from the Shelf, Slot, and Port drop-down lists.

The destination In and Out shelf (multishelf only), slot and port appear under the OTS (optical transport signal) Lines area to show the destination in and out shelf, slots, and ports.

Step 10 Click **Finish**. After the circuit status has been verified, the DISCOVERED status appears in the Status column. (The circuit might take a few minutes to come up, depending on the size of the network.) If problems occur, refer to the *Cisco ONS 15454 DWDM Troubleshooting Guide* as necessary.

Step 11 Return to your originating procedure (NTP).

DLP-G106 Delete Optical Channel Network Connections

Purpose	This task deletes DWDM OCHNC circuits.
Tools/Equipment	None
Prerequisite Procedures	DLP-G46 Log into CTC, page 2-25
Required/As Needed	As needed
Onsite/Remote	Onsite or remote
Security Level	Provisioning or higher



Note If you are deleting more than half of all the active OCHNCs, Cisco recommends that you delete them two at a time to allow for proper power compensation. This does not apply if you are deleting all the active OCHNCs.

Step 1 Complete the “[NTP-G103 Back Up the Database](#)” procedure on page 13-2, or record the circuit information if it will be recreated.

- Step 2** Consult your NOC or other appropriate personnel to verify that the OCHNC can be safely deleted.
- Step 3** Investigate all network alarms and resolve any problems that might be affected by the OCHNC deletion.
- Step 4** Choose **View > Go to Network View**.
- Step 5** Click the **Circuits** tab.
- Step 6** On the Circuits table, use the Circuit Name and Type columns to click the OCHNCs that you want to delete. (To choose more than one OCHNC, press the **Shift** key as you click the circuits.)
- Step 7** Click **Delete**.
- Step 8** In the Delete Circuits confirmation dialog box, check **Notify when completed**, as needed.
- If checked, the CTC Alerts confirmation dialog box indicates when the OCHNC is deleted. During this time, you cannot perform other CTC functions. If you are deleting many OCHNCs, waiting for confirmation might take a few minutes. Circuits are deleted whether or not this check box is checked.



Note The CTC Alerts dialog box will not automatically open to show a deletion error unless you checked All alerts or Error alerts only in the CTC Alerts dialog box. For more information, see the “[DLP-G53 Configure the CTC Alerts Dialog Box for Automatic Popup](#)” task on page 2-32. If the CTC Alerts dialog box is not set to open automatically with a notification, the red triangle inside the CTC Alerts toolbar icon indicates that a notification exists.

- Step 9** Complete one of the following:
- If you checked Notify when completed, the CTC Alerts dialog box appears. If you want to save the information, continue with [Step 10](#). If you do not want to save the information, continue with [Step 11](#).
 - If you did not check Notify when completed, the Circuits window appears. Continue with [Step 12](#).
- Step 10** If you want to save the information in the CTC Alerts dialog box, complete the following steps. If you do not want to save it, continue with [Step 11](#).
- a. Click **Save**.
 - b. Click **Browse** and navigate to the directory where you want to save the file.
 - c. Type the file name using a.txt file extension, and click **OK**.
- Step 11** Click **Close** to close the CTC Alerts dialog box.
- Step 12** Complete the “[NTP-G103 Back Up the Database](#)” procedure on page 13-2 if you require a backup of your changes.
- Step 13** Return to your originating procedure (NTP).
-

DLP-G426 Edit an OCHNC Circuit Name

Purpose	This task changes the name of an OCHNC circuit.
Tools/Equipment	None
Prerequisite Procedures	DLP-G105 Provision Optical Channel Network Connections, page 7-11 DLP-G46 Log into CTC, page 2-25
Required/As Needed	As needed
Onsite/Remote	Onsite or remote
Security Level	Provisioning or higher

-
- Step 1** From the View menu, choose **Go to Network View**.
- Step 2** Click the **Circuits** tab.
- Step 3** Click the OCHNC whose name you want to edit, then click **Edit**. The Edit Circuit dialog box appears with the General tab displayed.
- Step 4** In the Name field, enter the new OCHNC circuit name.
- Step 5** Click **Apply**.
- Step 6** Return to your originating procedure (NTP).
-

NTP-G150 Upgrade Optical Channel Network Connections to Optical Channel Client Connections

Purpose	This procedure upgrades OCHNCs created in earlier software releases to OCHCCs.
Tools/Equipment	None
Prerequisite Procedures	DLP-G105 Provision Optical Channel Network Connections, page 7-11
Required/As Needed	As needed
Onsite/Remote	Onsite or remote
Security Level	Provisioning or higher



Note

During this procedure, the OCHNC is replaced with two circuit types, the OCHCC, which establishes a connection between the client card client ports, and the OCH trail, which establishes a connection between the client card trunk ports. The OCH trail is given the same name as the OCHNC. The OCHCC is given a system-generated name in the format: *circuit-type_NE-name::unique sequence number*. To edit the OCHCC circuit name, complete the “[DLP-G424 Edit an OCHCC Circuit Name](#)” task on [page 7-9](#). To edit the OCH trail circuit name, complete the “[DLP-G424 Edit an OCHCC Circuit Name](#)” task on [page 7-9](#).

**Note**

Multiple OCHCCs might use the same OCH trail. The OCH Wlen (wavelength) parameter on the Circuits page can be used to determine the OCHCC and OCH trail associations.

-
- Step 1** As needed, identify the OCHCC to be provisioned using the “[DLP-G350 Use the Cisco MetroPlanner Traffic Matrix Report](#)” task on page 6-8.
- Step 2** Complete the [DLP-G46 Log into CTC, page 2-25](#) at a node on the network where you want to upgrade the OCHNCs. If you are already logged in, continue with [Step 3](#).
- Step 3** From the View menu, choose **Go to Network View**.
- Step 4** Click the **Circuits** tab and find the OCH you want to upgrade.
- Step 5** Record the following information:
- OCHNC Wlen (OCHNC wavelength)
 - Source node/shelf (if applicable)/slot/port/side (include both Side A and Side B nodes, if present)
 - Destination node/shelf (if applicable)/slot/port/side (include both Side A and Side B nodes, if present)
- Step 6** Use the information recorded in [Step 5](#) to complete one of the following
- [DLP-G344 Verify Provisionable Patchcords, page 7-18](#)—Complete this task if provisionable patchcords (PPCs) and internal patchcords exist on the network but you are not sure whether one was created for the OCHNC that you want to upgrade.
 - [DLP-G99 Create a Provisionable Patchcord, page 7-20](#)—Complete this procedure if you know that PPCs were not created between the OCHNC node and the client node. If you recently upgraded from a previous release, you must create PPCs between the source client and OCHNC node and between the destination client and OCHNC node.
- Step 7** In network view, click the OCHNC that you want to upgrade.
- Step 8** From the Tools menu, choose **Circuits > Upgrade OCHNC**. If the Upgrade OCHNC Initialization “Completed” status appears ([Figure 7-2](#)), continue with [Step 9](#). If the “Failed” status appears ([Figure 7-3](#)), complete the following substeps:
- a. Click each failure reason to view the failure details. A common cause of initialization failures is the absence or incorrect completion of PPCs or internal patchcords between the client nodes and the optical channel (OCH) nodes.
 - b. Repeat [Steps 3](#) through [8](#), verifying that the OCHNC ports and provisionable patchcord (PPC) path match on both sides. If the upgrade “Failed” status appears again, click **Save** to save the results to a local or network computer. (The file can be opened with any text editor.) Then, contact your next level of support.

Figure 7-2 Upgrade OCHNC Initialization—Completed

Click to display details

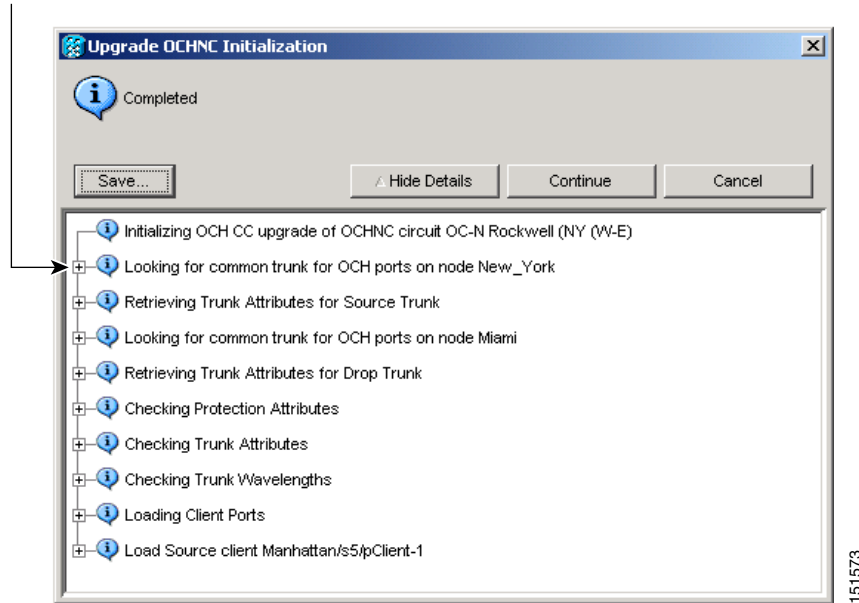
**Figure 7-3 Upgrade OCHNC Initialization—Failed**

Click to display details

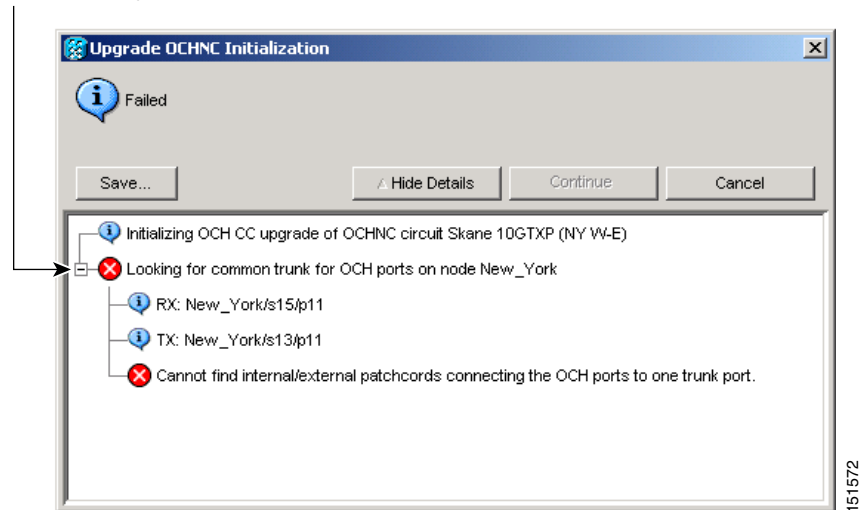

- Step 9** Click each result to review the details. If you want to save the results, click Save and save the results to a file on a local or network computer. Click **Continue**.
- Step 10** Review the information in the Upgrade OCHNC dialog box (Figure 7-4), then click **OK**.
- Step 11** Click **Yes** in the confirmation dialog box, then click **OK** on the Completed Upgrade OCHNC wizard page.

**Tip**

To see all of the information in the Source and Destination table cells, increase the column widths by clicking and dragging the column heading borders to the right or left.

Figure 7-4 Upgrade OCHNC Dialog Box

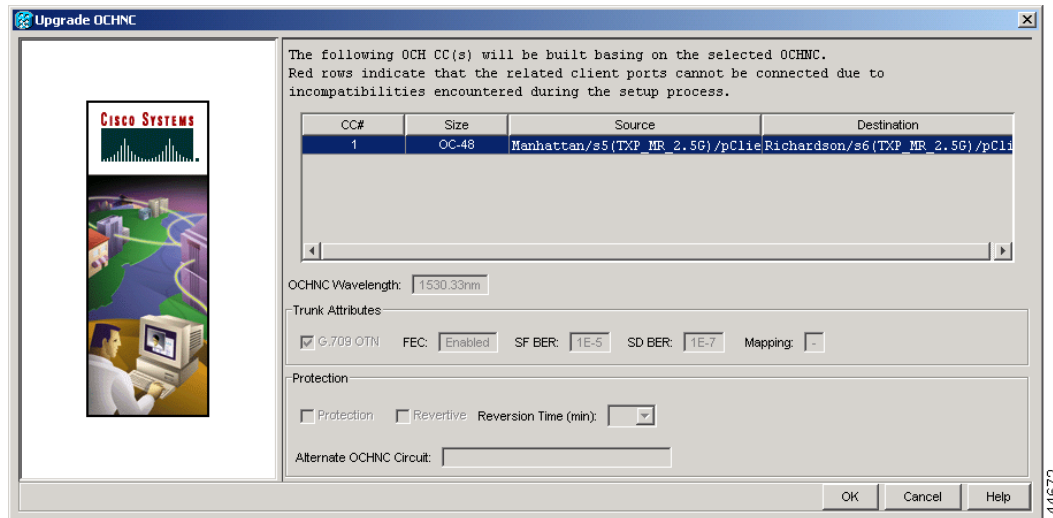

- Step 12** View the OCHCC and its OCH trail in the Circuits page. For information and procedures for viewing and editing OCHCC and OCH trails, see the [“NTP-G58 Locate and View Optical Channel Network and Client Connections” procedure on page 7-30](#).

Stop. You have completed this procedure.

DLP-G344 Verify Provisionable Patchcords

Purpose	This task verifies the PPCs that are required between client TXP/MXP/line cards and optical channel (OCH) DWDM nodes for OCHCCs. This task is not required for OCHNCs.
Tools/Equipment	None
Prerequisite Procedures	DLP-G46 Log into CTC, page 2-25
Required/As Needed	As needed
Onsite/Remote	Onsite or remote
Security Level	Provisioning or higher

- Step 1** In node view (single-shelf mode) or multishelf view (multishelf mode), Click the **Provisioning > Provisionable Patchcords (PPC)** tabs.
- Step 2** Use one of the following methods to verify that PPCs exist from the client TXP/MXP/line card node, slot, and port to the DWDM OCH node, slot, port, and wavelength:
- Review the Patchcord Terminations table. PPCs should exist from the client TXP/MXP/line card node to the OCH node slot and port recorded in the referring procedure.

- Review the network graphic (see Figure 7-5). PPCs are indicated by a small hand holding a lambda symbol. Clicking the PPC line on the graphic displays the PPC source and destination nodes, slots, and ports in the CTC information area. The information in the information area should match the node, slot, and port recorded in the referring procedure.

Figure 7-5 Viewing the Provisionable Patchcords Table

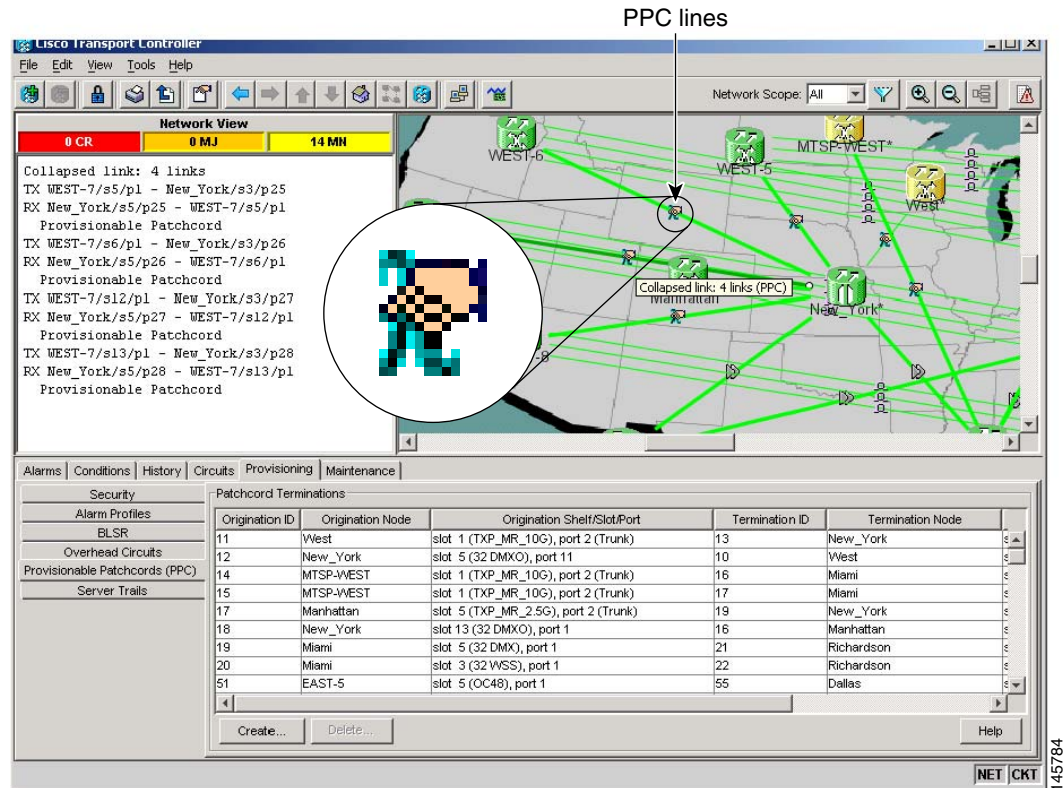

Step 3 Return to your originating procedure (NTP).

DLP-G99 Create a Provisionable Patchcord

Purpose	This task creates a provisionable patchcord (PPC), also called a virtual link. PPCs appear as dashed lines in CTC network view. PPCs are required for optical channel client connections (OCHCCs) when the transponder (TXP), muxponder (MXP), or optical line client cards are not installed in the same shelf (either single or multishelf) as the OCH (DWDM) cards. (PPCs are not required for OCHNCs.) PPCs create a virtual connection between the OCH and client nodes. For the specific situations in which a patchcord is necessary, refer to the “Management Network Connectivity” chapter in the <i>Cisco ONS 15454 DWDM Reference Manual</i> .
Tools/Equipment	OC-N, TXP, MXP, OADM, ROADM, multiplexer, and demultiplexer cards
Prerequisite Procedures	DLP-G46 Log into CTC, page 2-25
Required/As Needed	As needed
Onsite/Remote	Onsite or remote
Security Level	Provisioning or higher

Note

This task requires DCC or GCC connectivity between the OCH node and the subtended TXP, MXP, or line card client shelves.



Note

An optical port requires two patchcords when the remote end is Y-cable protected or is an add/drop multiplexer or multiplexer/demultiplexer port.

- Step 1** Complete the following tasks, as needed, to verify the cabling between the TXP/MXP/line cards in the client node and the OCH cards in the DWDM node:
- [DLP-G349 Use the Cisco MetroPlanner Internal Connections Report, page 3-58](#)
 - [DLP-G350 Use the Cisco MetroPlanner Traffic Matrix Report, page 6-8](#)
- Step 2** In node view (single-node view) or multishelf view (multishelf mode), click the **Provisioning > Comm Channels > PPC** tabs. If you are in network view, click the **Provisioning > PPC** tabs.
- Step 3** Click **Create**. The Provisionable Patchcord dialog box appears.
- Step 4** In the Origination Node area, choose the origination node. If you are in node view (single-shelf mode) or multishelf view (multishelf mode), the origination node defaults to the current node. If you are in network view, click the desired origination node from the drop-down list.
- Step 5** In the Termination Node area, click the desired termination node from the drop-down list. If the remote node has not previously been discovered by CTC but is accessible by CTC, type the name of the remote node.

After you enter a termination node, the dialog box expands so that the TX and RX ports appear ([Figure 7-6](#)) for both the origination and termination nodes.

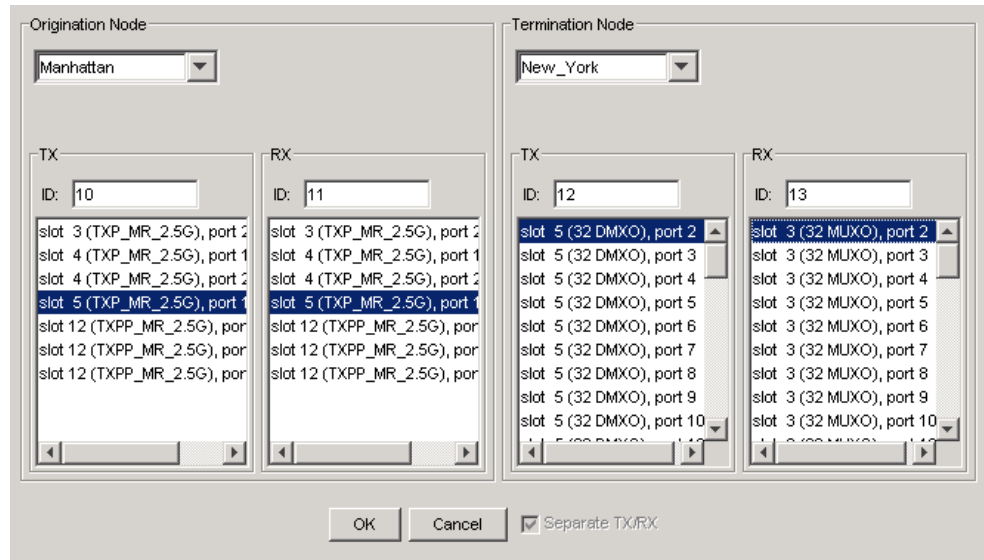
Figure 7-6 Create Provisionable Patchcord - Single Shelf to Single Shelf



- Step 6** Type a patchcord identifier (0 through 32767) in the TX and RX ID fields for the origination node and the termination node. The identifiers are used for your internal tracking and to help identify PPCs. All TX and RX IDs must be unique.
- Step 7** In the Origination Node area, click the desired origination slot/port from the list of available slots/ports. The origination ports and termination ports must be different. The TX and RX port selections will align automatically, depending on the card. For example, if you choose a TXP card in Slot 5 for the RX port, the TX will automatically change to Slot 5.
- Step 8** In the Termination Node area, click the desired termination slot/port from the list of available slots/ports. The origination ports and the termination ports must be different.
- Step 9** If you need to provision transmit (Tx) and receive (Rx) separately for multiplexer/demultiplexer cards, check the **Separate Tx/Rx** check box. If not, continue with [Step 10](#).
- Step 10** Click **OK**.
- Step 11** If you provisioned a patchcord on a port in a 1+1 protection group, a dialog box appears to ask if you would like to provision the peer patchcord. Click **Yes**. Repeat [Steps 4](#) through [10](#).
- Step 12** Return to your originating procedure.

NTP-G60 Create and Delete Overhead Circuits

Purpose	This procedure creates overhead circuits on an ONS 15454 network. Overhead circuits include ITU-T general communications channels (GCCs), the AIC-I card orderwire, and the AIC-I card UDC.
Tools/Equipment	None
Prerequisite Procedures	None
Required/As Needed	As needed

Onsite/Remote	Onsite or remote
Security Level	Provisioning or higher

-
- Step 1** Complete the “[DLP-G46 Log into CTC](#)” task on page 2-25 at the node where you will create the overhead circuit. If you are already logged in, continue with Step 2.
- Step 2** As needed, complete the “[DLP-G76 Provision DCC/GCC Terminations](#)” task on page 7-22.
- Step 3** As needed, complete the “[DLP-G97 Provision a Proxy Tunnel](#)” task on page 7-24.
- Step 4** As needed, complete the “[DLP-G98 Provision a Firewall Tunnel](#)” task on page 7-25.
- Step 5** As needed, complete the “[DLP-G109 Provision Orderwire](#)” task on page 7-26.
- Step 6** As needed, complete the “[DLP-G110 Create a User Data Channel Circuit](#)” task on page 7-28.
- Step 7** As needed, complete the “[DLP-G112 Delete Overhead Circuits](#)” task on page 7-29.

Stop. You have completed this procedure.

DLP-G76 Provision DCC/GCC Terminations

Purpose	This task creates the DWDM DCC/GCC terminations required for network setup when using the TXP and MXP cards. Perform this task before you create OCHCC or OCHNC circuits for these cards. In this task, you can also set up the node so that it has direct IP access to a far-end non-ONS node over the DCC/GCC network.
Tools/Equipment	None
Prerequisite Procedures	DLP-G46 Log into CTC, page 2-25
Required/As Needed	As needed
Onsite/Remote	Onsite or remote
Security Level	Provisioning or higher

-
- Step 1** If you are provisioning DCC termination on the TXP and MXP card, set the termination mode of the card as appropriate. For details, see the section “Termination Modes” in the chapter “Card Reference” of *Cisco ONS 15454 DWDM Reference Manual*.
- Step 2** If you are provisioning DCC termination, ensure that the OTN is disabled on OTN interfaces (usually trunk ports). If OTN is enabled, provision GCC instead of DCC termination. For more information about managing OTN setting on the card, see the procedures for changing card OTN settings in [Chapter 5, “Provision Transponder and Muxponder Cards”](#).
- Step 3** In node view (single-shelf mode) or multishelf view (multishelf mode), click the **Provisioning > Comm Channels > GCC** tabs.
- Step 4** Select the DCC or GCC tabs as necessary. Available tabs are:
- GCC (both ANSI and ETSI)
 - DCC
 - SDCC and LDCC (for ANSI)
 - RS-DCC and MS-DCC (for ETSI)

- Step 5** Click the **Create** button. The Create Terminations dialog box appears.
- Step 6** Select the ports where you want to create the DCC/GCC termination. To select more than one port, press the **Shift** key or the **Ctrl** key.
- Step 7** Under Port Admin State area, select one of the following:
- **Leave unchanged**—Does not change the DCC/GCC termination port administrative state.
 - **Set to IS** or **Set to Unlocked** —Puts the DCC/GCC termination port in service.
 - **Set OOS,DSLBD to IS,AINS** (for ANSI) or **Set Locked,disabled to Unlocked,automaticInService** (for ETSI)—Changes a port that is currently out of service or locked to automatic in service.
 - **Set OOS,DSLBD to OOS,MT** (for ANSI) or **Set Locked,disabled to Locked,maintenance** (for ETSI)—Changes a port that is currently out of service or locked to out of service for maintenance.



Note For GCC termination, the GCC Rate is set as 192 kbps by default. This rate currently cannot be changed.

- Step 8** Verify that the Disable OSPF on Link is unchecked. If this check box is checked, node discovery through the link termination will not happen.
- Step 9** If the DCC/GCC termination includes a non-ONS node, check the **Far End is Foreign** check box. This automatically sets the far-end node IP address to 0.0.0.0, which means that any address can be specified by the far end. To change the default to a specific IP address, see the [“DLP-G184 Change a DCC/GCC Termination” task on page 10-43](#).
- Step 10** In the Layer 3 area, perform one of the following:
- Check the IP box only if the DCC/GCC is between the ONS 15454 and another ONS node and only ONS nodes reside on the network. The DCC/GCC will use Point-to-Point Protocol (PPP).
 - Check the IP and OSI boxes if the DCC/GCC is between the ONS 15454 and another ONS node, and third party NEs that use the OSI protocol stack are on the same network. The DCC/GCC will use PPP.
- Step 11** If you checked OSI, complete the following steps. If you checked IP only, continue with [Step 12](#).
- a. Click **Next**.
 - b. Provision the following fields:
 - Router—Choose the OSI router.
 - ESH—Sets the End System Hello (ESH) propagation frequency. End system (ES) NEs transmit ESHs to inform other ESs and intermediate systems (ISs) about the Network Service Access Points (NSAPs) that they serve. The default is 10 seconds. The range is 10 to 1000 seconds.
 - ISH—Sets the Intermediate System Hello (ISH) PDU propagation frequency. IS NEs send ISHs to other ESs and ISs to inform them about the IS NEs that they serve. The default is 10 seconds. The range is 10 to 1000 seconds.
 - IIH—Sets the Intermediate System to Intermediate System Hello (IIH) PDU propagation frequency. The IS-IS Hello protocol data units (PDUs) establish and maintain adjacencies between ISs. The default is 3 seconds. The range is 1 to 600 seconds.
 - IS-IS Cost—Sets the cost for sending packets on the LAN subnet. The IS-IS protocol uses the cost to calculate the shortest routing path. The default metric cost for LAN subnets is 60. It normally should not be changed.
- Step 12** Click **Finish**. The following alarms appear until all the network DCC/GCC terminations are created and the ports are in service:

- GCC-EOC for GCC termination
- EOC for SDCC termination
- EOC-L for LDCC termination

Step 13 Return to your originating procedure (NTP).

DLP-G97 Provision a Proxy Tunnel

Purpose	This task sets up a proxy tunnel to communicate with a non-ONS far-end node. Proxy tunnels are only necessary when the proxy server is enabled and a foreign GCC termination exists, or if static routes exist so that the GCC network is used to access remote networks or devices. You can provision a maximum of 12 proxy server tunnels.
Tools/Equipment	None
Prerequisite Procedures	DLP-G46 Log into CTC, page 2-25 DLP-G76 Provision DCC/GCC Terminations, page 7-22
Required/As Needed	As needed
Onsite/Remote	Onsite or remote
Security Level	Superuser



Note If the proxy server is disabled, you cannot set up a proxy tunnel.

- Step 1** In node view (single-shelf mode) or multishelf view (multishelf mode), click the **Provisioning > Network > Proxy** tabs.
- Step 2** Click **Create**.
- Step 3** In the Create Tunnel dialog box, complete the following:
- **Source Address**—Type the IP address of the source node (32 bit length) or source subnet (any other length).
 - **Length**—Choose the length of the source subnet mask.
 - **Destination Address**—Type the IP address of the destination node (32 bit length) or destination subnet (any other length).
 - **Length**—Choose the length of the destination subnet mask.
- Step 4** Click **OK**.
- Step 5** Continue with your originating procedure (NTP).
-

DLP-G98 Provision a Firewall Tunnel

Purpose	This task provisions destinations that will not be blocked by the firewall. Firewall tunnels are only necessary when the proxy server is enabled and a foreign GCC termination exists, or if static routes exist so that the GCC network is used to access remote networks or devices. You can provision a maximum of 12 firewall tunnels.
Tools/Equipment	None
Prerequisite Procedures	DLP-G46 Log into CTC, page 2-25 DLP-G76 Provision DCC/GCC Terminations, page 7-22
Required/As Needed	As needed
Onsite/Remote	Onsite or remote
Security Level	Superuser



Note If the proxy server is configured as proxy-only or is disabled, you cannot set up a firewall tunnel.

-
- Step 1** In node view (single-shelf mode) or multishelf view (multishelf mode), click the **Provisioning > Network > Firewall** tabs.
- Step 2** Click **Create**.
- Step 3** In the Create Tunnel dialog box, complete the following:
- **Source Address**—Type the IP address of the source node (32 bit length) or source subnet (any other length).
 - **Length**—Choose the length of the source subnet mask.
 - **Destination Address**—Type the IP address of the destination node (32 bit length) or destination subnet (any other length).
 - **Length**—Choose the length of the destination subnet mask.
- Step 4** Click **OK**.
- Step 5** Continue with your originating procedure (NTP).
-

DLP-G108 Change the Service State for a Port

Purpose	This task puts a port in service or removes a port from service. After creating an IP-encapsulated tunnel, put the ports that are hosting the IP-encapsulated tunnel in service.
Tools/Equipment	None
Prerequisite Procedures	DLP-G46 Log into CTC, page 2-25
Required/As Needed	As needed
Onsite/Remote	Onsite or remote
Security Level	Provisioning or higher

-
- Step 1** In node view (single-shelf mode) or shelf view (multishelf mode) on the shelf graphic, double-click the card with the port(s) you want to put in or out of service. The card view appears.
- Step 2** Click the **Provisioning > Line** tabs.
- Step 3** In the Admin State column for the desired port, choose one of the following from the drop-down list:
- **IS (ANSI) or Unlocked (ETSI)**—Puts the port in the IS-NR (ANSI) or Unlocked-enabled (ETSI) service state.
 - **OOS,DSBLD (ANSI) or Locked,disabled (ETSI)**—Puts the port in the OOS-MA,DSBLD (ANSI) or Locked-enabled,disabled (ETSI) service state.
- For ANSI nodes, traffic is not passed on the port until the service state is changed to IS-NR; OOS-MA,MT; or Out-of-Service and Autonomous, Automatic In-Service (OOS-AU,AINS). For ETSI nodes, traffic is not passed on the port until the service state is changed to Unlocked-enabled; Locked-enabled,maintenance; or Unlocked-disabled,automaticInService.
- **OOS,MT (ANSI) or Locked,maintenance (ETSI)**—Puts the port in the OOS-MA,MT/Locked-enabled,maintenance service state. This service state does not interrupt traffic flow, but alarm reporting is suppressed and loopbacks are allowed. Raised fault conditions, whether or not their alarms are reported, can be retrieved on the CTC Conditions tab or by using the TL1 RTRV-COND command. Use the OOS-MA,MT/Locked-enabled,maintenance service state for testing or to suppress alarms temporarily. Change to the IS-NR/Unlocked-enabled or OOS-AU,AINS/Unlocked-disabled,automaticInService service states when testing is complete.
 - **IS,AINS (ANSI) or Unlocked,automaticInService (ETSI)**—Puts the port in the OOS-AU,AINS/Unlocked-enabled,automaticInService service state. In this service state, alarm reporting is suppressed, but traffic is carried and loopbacks are allowed. After the soak period passes, the port changes to IS-NR/Unlocked-enabled. Raised fault conditions, whether their alarms are reported or not, can be retrieved on the CTC Conditions tab or by using the TL1 RTRV-COND command.
- For more information about service states, refer to the “Administrative and Service States” appendix in the *Cisco ONS 15454 DWDM Reference Manual*.
- Step 4** If you set the Admin State field to IS-AINS or Unlocked,automaticInService, set the soak period time in the AINS Soak field. This is the amount of time that the port will stay in the OOS-AU,AINS or Unlocked-enabled,automaticInService service state after a signal is continuously received. When the soak period elapses, the port changes to the IS-NR or Unlocked-enabled service state.
- Step 5** Click **Apply**. The new port service state appears in the Service State column.
- Step 6** As needed, repeat this task for each port.
- Step 7** Return to your originating procedure (NTP).
-

DLP-G109 Provision Orderwire

Purpose	This task provisions orderwire on the AIC-I card.
Tools/Equipment	An AIC-I card must be installed in Slot 9. An OSCM, OSC-CSM, MXP_2.5_10E, MXP_2.5_10G, MXPP_MR_2.5G, or MXP_MR_2.5G card must be installed.
Prerequisite Procedures	DLP-G46 Log into CTC, page 2-25

Required/As Needed	As needed
Onsite/Remote	Onsite or remote
Security Level	Provisioning or higher

-
- Step 1** In network view, click the **Provisioning > Overhead Circuits** tabs.
- Step 2** Click **Create**.
- Step 3** In the Overhead Circuit Creation dialog box, complete the following fields in the Circuit Attributes area:
- **Name**—Assign a name to the circuit. The name can be alphanumeric and up to 48 characters (including spaces).
 - **Circuit Type**—Choose either **Local Orderwire** or **Express Orderwire** depending on the orderwire path that you want to create. If regenerators are not used between ONS 15454 nodes, you can use either local or express orderwire channels. If regenerators exist, use the express orderwire channel. You can provision up to four ONS 15454 OC-N ports for each orderwire path.
 - **PCM**—Choose the Pulse Code Modulation voice coding and companding standard, either **Mu_Law** (North America, Japan) or **A_Law** (Europe). The provisioning procedures are the same for both types of orderwire.

**Caution**

When provisioning orderwire for ONS 15454s residing in a ring, do not provision a complete orderwire loop. For example, a four-node ring typically has east and west ports provisioned at all four nodes. However, to prevent orderwire loops, provision two orderwire ports (east and west) at all but one of the ring nodes.

-
- Step 4** Click **Next**.
- Step 5** In the Circuit Source area, complete the following:
- **Node**—Choose the source node.
 - **Shelf**—(Multishelf mode only) Choose the source shelf.
 - **Slot**—Choose the source slot.
 - **Port**—If applicable, choose the source port.
- Step 6** Click **Next**.
- Step 7** In the Circuit Destination area, complete the following:
- **Node**—Choose the destination node.
 - **Shelf**—(Multishelf mode only) Choose the destination shelf.
 - **Slot**—Choose the destination slot.
 - **Port**—If applicable, choose the destination port.
- Step 8** Click **Finish**.
- Step 9** Return to your originating procedure (NTP).
-

DLP-G110 Create a User Data Channel Circuit

Purpose	This task creates a UDC circuit on the ONS 15454. A UDC circuit allows you to create a dedicated data channel between nodes.
Tools/Equipment	OSCM, OSC-CSM, MXPP_MR_2.5G, or MXP_MR_2.5G must be installed.
Prerequisite Procedures	DLP-G46 Log into CTC, page 2-25
Required/As Needed	As needed
Onsite/Remote	Onsite or remote
Security Level	Provisioning or higher

-
- Step 1** In network view, click the **Provisioning > Overhead Circuits** tabs.
- Step 2** Click **Create**.
- Step 3** In the Overhead Circuit Creation dialog box, complete the following fields in the Circuit Attributes area:
- Name—Assign a name to the circuit. The name can be alphanumeric and up to 48 characters (including spaces).
 - Type—Choose either **User Data-F1** or **User Data D-4-D-12** from the drop-down list. (User Data D-4-D-12 is not available if the ONS 15454 is provisioned for DWDM.)
- Step 4** Click **Next**.
- Step 5** In the Circuit Source area, complete the following:
- Node—Choose the source node.
 - Shelf—(Multishelf mode only) Choose the source shelf.
 - Slot—Choose the source slot.
 - Port—If applicable, choose the source port.
- Step 6** Click **Next**.
- Step 7** In the Circuit Destination area, complete the following:
- Node—Choose the destination node.
 - Shelf—(Multishelf mode only) Choose the destination shelf.
 - Slot—Choose the destination slot.
 - Port—If applicable, choose the destination port.
- Step 8** Click **Finish**.
- Step 9** Return to your originating procedure (NTP).
-

DLP-G112 Delete Overhead Circuits

Purpose	This task deletes overhead circuits. Overhead circuits include IP-encapsulated tunnels, AIC-I card orderwire, and UDCs.
Tools/Equipment	None
Prerequisite Procedures	DLP-G46 Log into CTC, page 2-25
Required/As Needed	As needed
Onsite/Remote	Onsite or remote
Security Level	Provisioning or higher



Caution

Deleting overhead circuits is service affecting if the circuits are in service (IS). To put circuits out of service (OOS), see the [“DLP-G108 Change the Service State for a Port” task on page 7-25](#).

-
- Step 1** From the View menu, choose **Go to Network View**.
 - Step 2** Click the **Provisioning > Overhead Circuits** tabs.
 - Step 3** Click the overhead circuit that you want to delete: local or express orderwire, user data, IP-encapsulated tunnel, or DCC tunnel.
 - Step 4** Click **Delete**.
 - Step 5** In the confirmation dialog box, click **Yes** to continue.
 - Step 6** Return to your originating procedure (NTP).
-

NTP-G62 Create a JO Section Trace

Purpose	This procedure creates a repeated, fixed-length string of characters used to monitor interruptions or changes to traffic between nodes.
Tools/Equipment	One TXP or MXP card must be installed.
Prerequisite Procedures	NTP-G32 Install the Transponder and Muxponder Cards, page 3-50
Required/As Needed	As needed (optional if path trace is set)
Onsite/Remote	Onsite or remote
Security Level	Provisioning or higher

-
- Step 1** Complete the [“DLP-G46 Log into CTC” task on page 2-25](#) at a node on the network where you will create the section trace. If you are already logged in, continue with Step 2.
 - Step 2** In node view (single-shelf mode) or shelf view (multishelf mode), double-click the TXP or MXP card.
 - Step 3** Click the **Provisioning > Line > Section Trace** tabs.
 - Step 4** From the Port drop-down list, choose the port for the section trace.
 - Step 5** From the Received Trace Mode drop-down list, enable the section trace expected string by choosing **Manual**.

- Step 6** In the Transmit Section Trace String Size area, click **1 byte** or **16 byte**. The 1 byte option allows you to enter one character and the 16 byte option allows a 15 character string.
- Step 7** In the New Transmit String field, enter the string that you want to transmit. Enter a string that makes the destination port easy to identify, such as the node IP address, node name, or another string. If the New Transmit String field is left blank, the J0 transmits a string of null characters.
- Step 8** If you set the Section Trace Mode field to Manual, enter the string that the destination port should receive from the source port in the New Expected String field.
- Step 9** Click the **Disable AIS and RDI if TIM-P is detected** check box if you want to suppress the alarm indication signal (AIS) and remote defect indication (RDI) when the STS Section Trace Identifier Mismatch Path (TIM-P) alarm appears. Refer to the *Cisco ONS 15454 DWDM Troubleshooting Guide* for descriptions of alarms and conditions.
- Step 10** Click **Apply**.
- Step 11** After you set up the section trace, the received string appears in the Received field. The following options are available:
- Click **Hex Mode** to display section trace in hexadecimal format. The button name changes to ASCII Mode. Click it to return the section trace to ASCII format.
 - Click the **Reset** button to reread values from the port.
 - Click **Default** to return to the section trace default settings (Section Trace Mode is set to Off and the New Transmit and New Expected Strings are null).

**Caution**

Clicking Default will generate alarms if the port on the other end is provisioned with a different string.

The expect and receive strings are updated every few seconds.

Stop. You have completed this procedure.

NTP-G58 Locate and View Optical Channel Network and Client Connections

Purpose	This procedure allows you to locate and view DWDM OCHNCs and OCHCCs. You can also export circuit data from the Circuits and Edit Circuits windows.
Tools/Equipment	None
Prerequisite Procedures	DLP-G105 Provision Optical Channel Network Connections, page 7-11 DLP-G346 Provision Optical Channel Client Connections, page 7-4
Required/As Needed	As needed
Onsite/Remote	Onsite or remote
Security Level	Retrieve or higher

- Step 1** Complete the “[DLP-G46 Log into CTC](#)” task on page 2-25 at a node on the network where you want to view the circuits. If you are already logged in, continue with Step 2.



Note Do not check Disable Circuit Management in the Login dialog box. No circuits appear if this option is checked.

- Step 2** As needed, complete the “[DLP-G100 Search for Optical Channel Network and Client Connections](#)” task on page 7-31.
- Step 3** As needed, complete the “[DLP-G101 View Optical Channel Network and Client Connection Information](#)” task on page 7-32.
- Step 4** As needed, complete the “[DLP-G102 Filter the Display of Optical Channel Network and Client Connections](#)” task on page 7-35.
- Step 5** As needed, complete the “[DLP-G103 View Optical Channel Network Connections on a Span](#)” task on page 7-37.
- Step 6** As needed, complete the [DLP-G114 Export CTC Data](#), page 8-4.
- Stop. You have completed this procedure.**

DLP-G100 Search for Optical Channel Network and Client Connections

Purpose	This task searches for DWDM OCHNCs, OCHCCs, and ONS 15454 circuits at the network, node, or card level.
Tools/Equipment	None
Prerequisite Procedures	DLP-G46 Log into CTC , page 2-25
Required/As Needed	As needed
Onsite/Remote	Onsite or remote
Security Level	Retrieve or higher

- Step 1** Navigate to the appropriate Cisco Transport Controller (CTC) view:
- To search the entire network, choose **View > Go to Network View**.
 - To search for circuits that originate, terminate, or pass through a specific node, choose **View > Go to Other Node**, then choose the node you want to search and click **OK**.
 - To search for circuits that originate, terminate, or pass through a specific card, double-click the card on the shelf graphic in node view (single-shelf mode) or shelf view (multishelf mode) to open the card in card view.
- Step 2** Click the **Circuits** tab.
- Step 3** If you are in node or card view, choose the scope for the search, **Node** or **Network (All)**, in the Scope drop-down list located at the bottom right side of the screen. Choose **Node** to see all of the circuits on that node, or **Network (All)** to see all circuits in the network.
- Step 4** Click **Search** if you need to search through the list of circuits.
- Step 5** In the Circuit Name Search dialog box, complete the following:
- Find What—Enter the text of the circuit name you want to find. This field is not case-sensitive.
 - Match whole word only—Check this check box to instruct CTC to select circuits only if the entire word matches the text in the Find What field.

- Match case—Check this check box to instruct CTC to select circuits only when the capitalization matches the capitalization entered in the Find What field.
 - Direction—Choose the direction for the search. Searches are conducted up or down from the currently selected circuit.
- Step 6** Click **Find Next**. If a match is found the circuit will be highlighted on the Circuits window. To continue the search, click **Find Next** again to find the next circuit.
- Step 7** Repeat Steps 5 and 6 until you are finished, then click **Cancel**.
- Step 8** Return to your originating procedure (NTP).

DLP-G101 View Optical Channel Network and Client Connection Information

Purpose	This task provides information about DWDM OCHNCs, OCHCCs, and ONS 15454 circuits.
Tools/Equipment	None
Prerequisite Procedures	DLP-G46 Log into CTC, page 2-25
Required/As Needed	As needed
Onsite/Remote	Onsite or remote
Security Level	Retrieve or higher

- Step 1** Navigate to the appropriate CTC view:
- To view circuits for an entire network, choose **View > Go to Network View**.
 - To view circuits that originate, terminate, or pass through a specific node, choose **View > Go to Other Node**, then choose the node you want to search and click **OK**.
 - To view circuits that originate, terminate, or pass through a specific card, in node view (single-shelf mode) or shelf view (multishelf mode), double-click the card containing the circuits you want to view.



Note In node or card view, you can change the scope of the circuits that appear by choosing Card (in card view), Node, or Network from the Scope drop-down list in the bottom right corner of the Circuits window.

- Step 2** Click the **Circuits** tab. The Circuits tab shows the following information:



Note The following order is the default column sequence, the order might be different on your screen, depending on your individual CTC setup.

- Circuit Name—Name of the circuit. The circuit name can be manually assigned or automatically generated.
- Type—Circuit types are OCHNC, OCHCC, and OCH-Trail.



Note The following circuit types are not applicable to DWDM nodes: STS, VT, VTT (VT tunnel), VAP (VT aggregation point), STS-v (STS VCAT circuit), VT-v (VT VCAT circuit), HOP (high-order circuit), LOP (low-order circuit), VCT (VC low-order tunnel), and VCA (low-order VCAT circuit).

- Size—Circuit size. OCHNC, OCHCC, and OCH-Trail sizes are Equipped not specific, Multi-rate, 2.5 Gbps No FEC (forward error correction), 2.5 Gbps FEC, 10 Gbps No FEC, and 10 Gbps FEC.



Note The following circuit types under the circuit size column are not applicable to DWDM nodes: STS, VT, VCAT, VC12, VC11, VC3, and VC4.

- OCHNC Wlen—The wavelength provisioned for the OCHNC, OCHCC, or OCH trail. See [Table 7-2 on page 7-12](#) for a list of channels and wavelengths.
- Direction—The circuit direction, either two-way or one-way.
- OCHNC Dir—The line direction of the OCHNC, OCHCC, or OCH trail, either East to West or West to East. If the direction is West to East, the channel exits from the node through the LINE-TX port of the east OSC-CSM, OPT-BST-E, or OPT-BST-E card, named the East Side Card by Cisco MetroPlanner (typically these cards are hosted in Slot 17). If the direction is East to West, the channel exits from the node through the LINE-TX port of the west OSC-CSM, or OPT-BST, or OPT-BST-E card, named the West Side Card by Cisco MetroPlanner (typically these cards are hosted in Slot 1).
- Protection—The type of circuit protection. See [Table 7-3 on page 7-34](#) for a list of protection types.
- Status—The circuit status. [Table 7-4 on page 7-34](#) lists the circuit statuses that can appear.
- Source—The circuit source in the format: *node/slot/port “port name”*. The port name will appear in quotes only if a name was assigned to it. (To assign names to ports, see the “[DLP-G104 Assign a Name to a Port](#)” task on page 7-3.
- Destination—The circuit destination in the format: *node/slot/port “port name”*. The port name will appear in quotes only if a name was assigned to it. (To assign names to ports, see the “[DLP-G104 Assign a Name to a Port](#)” task on page 7-3.
- # of VLANs—The number of VLANs used by an Ethernet circuit. VLANs are not applicable to DWDM nodes.
- # of Spans—The number of internode links that constitute the circuit. Right-clicking the column title shows a shortcut menu from which you can choose Span Details to show or hide circuit span detail.
- State—The circuit service state, which is an aggregate of its cross-connects. For ANSI, the service state is IS, OOS, or OOS-PARTIAL. For ETSI, the service state is Unlocked, Locked, or Locked-partial. For more information about ANSI and ETSI service states, see the “Administrative and Service States” appendix in the *Cisco ONS 15454 DWDM Reference Manual*.
 - IS/Unlocked—All cross-connects are in service and operational.
 - OOS/Locked—For ANSI, all cross-connects are Out-of-Service and Management, Maintenance (OOS-MA,MT) and/or Out-of-Service and Management, Disabled (OOS-MA,DSBLD). For ETSI, all cross-connects are Locked-enabled,maintenance and/or Locked-enabled,disabled.
 - OOS-PARTIAL/Locked-partial—At least one cross-connect is In-Service and Normal (IS-NR) (ANSI) or Unlocked-enabled (ETSI) and others are out-of-service.



Note Right-clicking a column title (Circuit name, Type, etc.) opens a shortcut menu that allows you to show or hide the desired circuit details.

Table 7-3 *Circuit Protection Types*

Protection Type	Description
Y-cable	(OCHNC and OCH-Trail circuit types only) The circuit is protected by a transponder or muxponder card Y-cable protection group.
Splitter	The circuit is protected by the protect transponder splitter protection.
Unprot	A circuit with a source and destination on different nodes is not protected.
N/A	A circuit with connections on the same node is not protected.
Unknown	A circuit has a source and destination on different nodes and communication is down between the nodes. This protection type appears if not all circuit components are known.

Table 7-4 *Cisco ONS 15454 Circuit Status*

Status	Definition/Activity
CREATING	CTC is creating a circuit.
DISCOVERED	CTC created a circuit. All components are in place and a complete path exists from the circuit source to the circuit destination.
DELETING	CTC is deleting a circuit.
PARTIAL	<p>A CTC-created circuit is missing a cross-connect or network span, a complete path from source to destination(s) does not exist, or an alarm interface panel (AIP) change occurred on one of the circuit nodes and the circuit is in need of repair. (AIPs store the node MAC address.)</p> <p>In CTC, circuits are represented using cross-connects and network spans. If a network span is missing from a circuit, the circuit status is PARTIAL. However, a PARTIAL status does not necessarily mean that a circuit traffic failure has occurred, because traffic might flow on a protect path.</p> <p>Network spans are in one of two states: up or down. On CTC circuit and network maps, up spans are shown as green lines, and down spans are shown as gray lines. If a failure occurs on a network span during a CTC session, the span remains on the network map but its color changes to gray to indicate the span is down. If you restart your CTC session while the failure is active, the new CTC session cannot discover the span and its span line will not appear on the network map.</p> <p>Subsequently, circuits routed on a network span that goes down will appear as DISCOVERED during the current CTC session, but they will appear as PARTIAL to users who log in after the span failure.</p> <p>This status does not appear for OCHNC circuit types.</p>

Table 7-4 Cisco ONS 15454 Circuit Status (continued)

Status	Definition/Activity
DISCOVERED_TL1	A TL1-created circuit or a TL1-like CTC-created circuit is complete. A complete path from source to destination(s) exists. This status does not appear for OCHNC circuit types.
PARTIAL_TL1	A TL1-created circuit or a TL1-like CTC-created circuit is missing a cross-connect, and a complete path from source to destination(s) does not exist. This status does not appear for OCHNC circuit types.

Step 3 Return to your originating procedure (NTP).

DLP-G102 Filter the Display of Optical Channel Network and Client Connections

Purpose	This task filters the display of DWDM OCHNCs, OCHCCs, as well as SONET or SDH circuits in the Circuits window. You can filter the circuits in network, node, or card view based on circuit or OCHNC name, size, type, direction, and other attributes.
Tools/Equipment	None
Prerequisite Procedures	DLP-G46 Log into CTC, page 2-25
Required/As Needed	As needed
Onsite/Remote	Onsite or remote
Security Level	Retrieve or higher

Step 1 Navigate to the appropriate CTC view:

- To filter network circuits, choose **View > Go to Network View**.
- To filter circuits that originate, terminate, or pass through a specific node, choose **View > Go to Other Node**, then choose the node you want to search and click **OK**.
- To filter circuits that originate, terminate, or pass through a specific card, double-click the card on the shelf graphic in node view (single-shelf mode) or shelf view (multishelf mode) to open the card in card view.

Step 2 Click the **Circuits** tab.

Step 3 Set the attributes for filtering the circuit display:

- Click the **Filter** button.
- In the General tab of the Circuit Filter dialog box, set the following filter attributes, as necessary:
 - Name—Enter a complete or partial circuit name to filter circuits based on the circuit name; otherwise leave the field blank.
 - Direction—Choose one: **Any** (direction not used to filter circuits), **1-way** (display only one-way circuits), or **2-way** (display only two-way circuits).

- OCHNC Dir—(DWDM OCHNCs only) Choose one: **East to West** (displays only east-to-west circuits) or **West to East** (displays only west-to-east circuits).
- OCHNC Wlen—(DWDM OCHNCs only) Choose an OCHNC wavelength to filter the circuits. For example, choosing 1530.33 will display channels provisioned on the 1530.33-nm wavelength.
- Status—Choose one: **Any** (status not used to filter circuits) or **Discovered** (display only discovered circuits). Other statuses do not apply to OCHNCs.
- State—Choose one: **OOS** (ANSI) or **Locked** (ETSI) to display only out-of-service circuits; **IS** (ANSI) or **Unlocked** (ETSI) to display only in-service circuits (OCHNCs have IS/Unlocked states only); or **OOS-PARTIAL** (ANSI) or **Locked-partial** (ETSI) to display only circuits with cross-connects in mixed service states.
- Protection—Enter the circuit protection type to filter circuits based on their protection.
- Shelf—(multishelf nodes only)—Enter the shelf name to filter circuits based on that shelf.
- Slot—Enter a slot number to filter circuits based on the source or destination slot; otherwise leave the field blank.
- Port—Enter a port number to filter circuits based on the source or destination port; otherwise leave the field blank.
- Type—Choose one: **Any** (type not used to filter circuits), **OCHNC** (displays only OCHNCs), **OCHCC** (displays only OCHCCs), or **OCH-Trail** (displays only OCH trail circuits).

**Note**

The following circuit types are not applicable to DWDM nodes: STS (displays only STS circuits), VT (displays only VT circuits), VT Tunnel (displays only VT tunnels), STS-V (displays STS VCAT circuits), VT-V (displays VT VCAT circuits), and VT Aggregation Point (displays only VT aggregation points), VC_HO_PATH_CIRCUIT (displays VC4 and VC4-Nc circuits), VC_LO_PATH_CIRCUIT (displays only VC3 and VC12 circuits), VC_LO_PATH_TUNNEL (displays only low-order tunnels), VC_LO_PATH_AGGREGATION (displays only log-order aggregation points), VC_HO_PATH_VCAT_CIRCUIT (displays high-order VCAT circuits), and VC_LO_PATH_VCAT_CIRCUIT (displays low-order VCAT circuits).

- Size—Click the appropriate check boxes to filter circuits based on size. The following sizes are available, depending on the circuit type: **Multi-rate**, **Equipment non specific**, **2.5 Gbps FEC**, **2.5 Gbps No FEC**, **10 Gbps FEC**, and **10 Gbps No FEC**.

**Note**

VT1.5, STS-1, STS3c, STS-6c, STS-9c, STS-12c, STS-24c, STS-48c, and STS-192c are not applicable to ANSI DWDM nodes. VC12, VC3, VC4, VC4-2c, VC4-3c, VC4-4c, VC4-6c, VC4-8c, VC4-9c, VC4-16c, and VC4-64 are not applicable to ETSI DWDM nodes.

The check boxes shown depend on the Type field selection. If you chose Any, all sizes are available. If you chose OCHNC as the circuit type, only Multi-rate, Equipment non specific, 2.5 Gbps FEC, 2.5 Gbps No FEC, 10 Gbps FEC, and 10 Gbps No FEC appear. If you choose OCHCC, only OCHCC is available. If you choose OCH Trail, only Equipment non specific is available.

Step 4 To set the filter for ring, node, link, and source and drop type, click the **Advanced** tab and complete the following. If you do not want to make advanced filter selections, continue with [Step 5](#).

- If you made selections on the General tab, click **Yes** in the confirmation box to apply the settings.

- b. In the Advanced tab of the Circuit Filter dialog box, set the following filter attributes as necessary:
- Ring—Choose the ring from the drop-down list.
 - Node—Click the check boxes by each node in the network to filter circuits based on node.
 - Link—Choose the desired link in the network.
 - Source/Drop—Choose one of the following to filter circuits based on whether they have one or multiple sources and drops: **One Source and One Drop Only** or **Multiple Sources or Multiple Drops**.
- Step 5** Click **OK**. Circuits matching the attributes in the Filter Circuits dialog box appear in the Circuits window.
- Step 6** To turn filtering off, click the Filter icon in the lower right corner of the Circuits window. Click the icon again to turn filtering on, and click the **Filter** button to change the filter attributes.
- Step 7** Return to your originating procedure (NTP).

DLP-G103 View Optical Channel Network Connections on a Span

Purpose	This task allows you to view OCHNCs and OCHCCs circuits on an ONS 15454 span.
Tools/Equipment	None
Prerequisite Procedures	DLP-G46 Log into CTC, page 2-25
Required/As Needed	As needed
Onsite/Remote	Onsite or remote
Security Level	Retrieve or higher

- Step 1** In node view (single-shelf mode) or multishelf view (multishelf mode), choose **View > Go to Network View**. If you are already in network view, continue with [Step 2](#).
- Step 2** Right-click the green line between the nodes containing the circuits that you want to view and choose **Circuits** to view DWDM OCHNCs, OCHCCs, or unprotected circuits on the span.
- Step 3** In the Circuits on Span dialog box, view information about the circuits that traverse the span. The information that appears depends on the circuit type. For DWDM OCHNCs, the following information appears:
- Type—The type of circuit, OCHNC, OCHCC, or OCH-Trail.
 - Size—The circuit size.
 - OCHNC Wavelength—The wavelength provisioned for the OCHNC.
 - DIR—2-way or 1-way.
 - Circuit—The OCHNC circuit name.
 - OCHNC Dir—The direction provisioned for the OCHNC, either east-to-west or west-to-east.
- Step 4** Return to your originating procedure (NTP).



Manage Alarms



Note

The terms "Unidirectional Path Switched Ring" and "UPSR" may appear in Cisco literature. These terms do not refer to using Cisco ONS 15xxx products in a unidirectional path switched ring configuration. Rather, these terms, as well as "Path Protected Mesh Network" and "PPMN," refer generally to Cisco's path protection feature, which may be used in any topological network configuration. Cisco does not recommend using its path protection feature in any particular topological network configuration.

This chapter contains the procedures for viewing and managing the alarms and conditions on a Cisco ONS 15454.

Cisco Transport Controller (CTC) detects and reports alarms generated by the Cisco ONS 15454 and the Optical Networking System (ONS) network. You can use CTC to monitor and manage alarms at card, node, or network level. You can also view alarm counts on the LCD front panel.



Note

Unless otherwise specified, "ONS 15454" refers to both ANSI and ETSI shelf assemblies.

Before You Begin

This section lists the chapter procedures (NTPs). Turn to a procedure for applicable tasks (DLPs).

1. [NTP-G63 Document Existing Provisioning, page 8-2](#)—Complete this procedure as needed to print or export node data.
2. [NTP-G64 View Alarms, History, Events, and Conditions, page 8-6](#)—Complete this procedure as needed to see alarms and conditions occurring on the node and a complete history of alarm and condition messages.
3. [NTP-G65 Delete Cleared Alarms from Display, page 8-14](#)—Complete this procedure as needed to delete cleared alarm information.
4. [NTP-G66 View Alarm-Affected Circuits, page 8-15](#)—Complete this procedure as needed to find circuits that are affected by a particular alarm or condition.
5. [NTP-G67 View Alarm Counts on the LCD for a Node, Slot, or Port, page 8-15](#)—Complete this procedure as needed to see a statistical count of alarms that have occurred for a slot or port.
6. [NTP-G68 Create, Download, and Assign Alarm Severity Profiles, page 8-17](#)—Complete this procedure as needed to change the default severity for certain alarms, to assign the new severities to a port, card, or node, and to delete alarm profiles.

7. [NTP-G69 Enable, Modify, or Disable Alarm Severity Filtering, page 8-25](#)—Complete this procedure as needed to enable, disable, or modify alarm severity filtering in the Conditions, Alarms, or History screens at the node or network level.
8. [NTP-G70 Suppress Alarms or Discontinue Alarm Suppression, page 8-29](#)—Complete this procedure as needed to suppress reported alarms at the port, card, or node level and to disable the suppress command to resume normal alarm reporting.
9. [NTP-G72 Provision External Alarms and Controls on the Alarm Interface Controller-International Card, page 8-32](#)—Complete this procedure as needed to provision external alarms and controls on the Alarm Interface Controller–International (AIC-I) card.

NTP-G63 Document Existing Provisioning

Purpose	Use this procedure to document existing provisioning by printing card, node, or network CTC information or exporting card, node, or network information as delineated text files to other applications. This procedure is useful for network record keeping and troubleshooting.
Tools/Equipment	A printer connected to the CTC computer by a direct or network connection
Prerequisite Procedures	Chapter 3, “Turn Up a Node”
Required/As needed	As needed
Onsite/Remote	Onsite or remote
Security Level	Retrieve or higher

Step 1 Complete the [“DLP-G46 Log into CTC” task on page 2-25](#) at the node where you want to print or export data. If you are already logged in, continue with [Step 2](#).

Step 2 As needed, complete the [“DLP-G113 Print CTC Data” task on page 8-2](#).

Step 3 As needed, complete the [“DLP-G114 Export CTC Data” task on page 8-4](#).

Stop. You have completed this procedure.

DLP-G113 Print CTC Data

Purpose	This task prints CTC card, node, or network data in graphical or tabular format on a Windows-provisioned printer.
Tools/Equipment	Printer connected to the CTC computer by a direct or network connection
Prerequisite procedures	DLP-G46 Log into CTC, page 2-25
Required/As needed	As needed
Onsite/Remote	Onsite or remote
Security Level	Retrieve or higher

Step 1 Click the tab (and subtab, if present) containing the information you want to print. For example, click the **Alarms** tab to print Alarms window data.

The print operation is available for all network, node, and card view windows.

Step 2 From the File menu choose **Print**. The Print dialog box appears (Figure 8-1).

Figure 8-1 Selecting CTC Data For Print

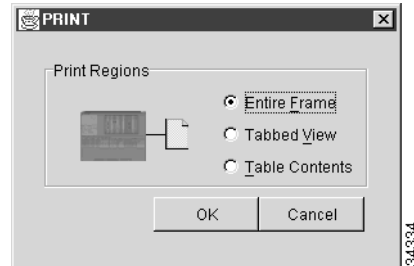

Step 3 In the Print dialog box, click a printing option:

- Entire Frame—Prints the entire CTC window including the graphical view of the card, node, or network. This option is available for all windows.
- Tabbed View—Prints the lower half of the CTC window containing tabs and data. The printout includes the selected tab (on top) and the data shown in the tab window. For example, if you print the History window Tabbed View, you print only history items appearing in the window. This option is available for all windows.
- Table Contents—Prints CTC data in table format without graphical representations of shelves, cards, or tabs. This option applies to all windows except:
 - Node view (single-shelf mode) or multishelf view (multishelf mode) Provisioning > General > General and Power Monitor windows
 - Node view (single-shelf mode) or multishelf view (multishelf mode) Provisioning > Network > General windows
 - Node view (single-shelf mode) or multishelf view (multishelf mode) Provisioning > Security > Policy, Access, and Legal Disclaimer windows
 - Node view (single-shelf mode) or multishelf view (multishelf mode) Provisioning > SNMP window
 - Node view (single-shelf mode) or shelf view (multishelf mode) Provisioning > Timing window > General and BITS Facilities windows
 - Node view (single-shelf mode) or multishelf view (multishelf mode) Provisioning > OSI > Main Setup and TARP windows
 - Node view (single-shelf mode) or multishelf view (multishelf mode) Provisioning > WDM-ANS > Node Setup windows
 - Node view (single-shelf mode) or shelf view (multishelf mode) Maintenance > Overhead XConnect window
 - Node view (single-shelf mode) or multishelf view (multishelf mode) Maintenance > Database window
 - Node view (single-shelf mode), multishelf view (multishelf mode), or shelf view (multishelf mode) Maintenance > Diagnostic window
 - Node view (single-shelf mode) or shelf view (multishelf mode) Maintenance > Protection window
 - Node view (single-shelf mode) or shelf view (multishelf mode) Maintenance > Timing > Source window

The Table Contents option prints all the data contained in a table and the table column headings. For example, if you print the History window Table Contents view, you print all data included in the table whether or not items appear in the window.



Tip When you print using the Tabbed View option, it can be difficult to distinguish whether the printout applies to the network, node, or card view. To determine the view, compare the tabs on the printout. The network, node, and card views are identical except that network view does not contain an Inventory tab or Performance tab.

- Step 4** Click **OK**.
- Step 5** In the Windows Print dialog box, click a printer and click **OK**.
- Step 6** Repeat this task for each window that you want to print.
- Step 7** Return to your originating procedure (NTP).

DLP-G114 Export CTC Data

Purpose	This task exports CTC table data as delineated text to view or edit the data in text editor, word processing, spreadsheet, database management, or web browser applications.
Tools/Equipment	None
Prerequisite procedures	DLP-G46 Log into CTC, page 2-25
Required/As needed	As needed
Onsite/Remote	Onsite or remote
Security Level	Retrieve or higher

- Step 1** Click the tab containing the information you want to export (for example, the Alarms tab or the Circuits tab).
- Step 2** If you want to export detailed circuit information, complete the following:
- In the Circuits window, choose a circuit and click **Edit** to open it in the Edit Circuits window.
 - In the Edit Circuits window, choose the desired tab: Drops, UPSR/SNCP Selectors, UPSR/SNCP Switch Counts, State, or Merge.



Note Depending upon your configuration, you may or may not see all of the above tabs when you click Edit.

- Step 3** Choose **Export** from the File menu. The Export dialog box appears ([Figure 8-2](#)).

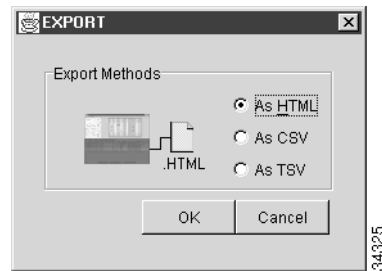
Figure 8-2 Selecting CTC Data For Export

Step 4 In the Export dialog box, click a data format:

- **As HTML**—Saves data as a simple HTML table file without graphics. The file must be viewed or edited with applications such as Netscape Navigator, Microsoft Internet Explorer, or other applications capable of opening HTML files.
- **As CSV**—Saves the CTC table as comma-separated values (CSV). This option does not apply to the Node view (single-shelf mode) or shelf view (multishelf mode) Maintenance > Timing > Report window.
- **As TSV**—Saves the CTC table as tab-separated values (TSV).

Step 5 If you want to open a file in a text editor or word processor application, procedures will vary. Typically, you can use the File > Open command to view the CTC data, or you can double-click the file name and choose an application such as Notepad.

Text editor and word processor applications format the data exactly as it is exported, including comma or tab separators. All applications that open the data files allow you to format the data.

Step 6 If you want to open the file in spreadsheet and database management applications, procedures will vary. Typically, you need to open the application and choose File > Import, then choose a delimited file to format the data in cells.

Spreadsheet and database management programs also allow you to manage the exported data.



Note An exported file cannot be opened in CTC.

The export operation applies to all tabular data except:

- Circuits (Edit option, General and Monitor windows)
- Node view (single-shelf mode) or multishelf view (multishelf mode) Provisioning > General > General and Power Monitor windows
- Node view (single-shelf mode) or multishelf view (multishelf mode) Provisioning > Network > General window
- Node view (single-shelf mode) or multishelf view (multishelf mode) Provisioning > Security > Policy, Access, and Legal Disclaimer windows
- Provisioning > SNMP window
- Node view (single-shelf mode) or shelf view (multishelf mode) Provisioning > Timing > General and BITS Facilities windows
- Node view (single-shelf mode) or multishelf view (multishelf mode) Provisioning > OSI > Main Setup window

- Node view (single-shelf mode) or multishelf view (multishelf mode) Provisioning > OSI > TARP > Config window
- Node view (single-shelf mode) or multishelf view (multishelf mode) Provisioning > WDM-ANS > Node Setup window
- Node view (single-shelf mode) or shelf view (multishelf mode) Maintenance > Overhead XConnect window
- Node view (single-shelf mode) or multishelf view (multishelf mode) Maintenance > Database window
- Node view (single-shelf mode), multishelf view (multishelf mode), or shelf view (multishelf mode) Maintenance > Diagnostic window
- Node view (single-shelf mode) or shelf view (multishelf mode) Maintenance > Protection window
- Node view (single-shelf mode) or shelf view (multishelf mode) Maintenance > Timing > Source windows
- Node view (single-shelf mode) or multishelf view (multishelf mode) Maintenance > DWDM > ROADM Power Monitoring window [ETSI only]

Step 7 Click **OK**.

Step 8 In the Save dialog box, enter a name in the File name field using one of the following formats:

- *filename.html* for HTML files
- *filename.csv* for CSV files
- *filename.tsv* for TSV files

Step 9 Navigate to a directory where you want to store the file.

Step 10 Click **Save**.

Step 11 Repeat the task for each window that you want to export.

Step 12 Return to your originating procedure (NTP).

NTP-G64 View Alarms, History, Events, and Conditions

Purpose	Use this procedure to view current or historical alarms and conditions for a card, node, or network. This information is useful for monitoring and troubleshooting hardware and software events.
Tools/Equipment	None
Prerequisite Procedures	None
Required/As Needed	As needed
Onsite/Remote	Onsite or remote
Security Level	Provisioning or higher

Step 1 Complete the [“DLP-G46 Log into CTC” task on page 2-25](#).

Step 2 Complete the [“DLP-G115 View Alarms” task on page 8-7](#) as needed.

Step 3 Complete the [“DLP-G116 View Alarm or Event History” task on page 8-8](#) as needed.

- Step 4** Complete the “[DLP-G117 Change the Maximum Number of Session Entries for Alarm History](#)” task on [page 8-10](#) as needed.
- Step 5** Complete the “[DLP-G118 Display Alarms and Conditions Using Time Zone](#)” task on [page 8-11](#) as needed.
- Step 6** Complete the “[DLP-G119 Synchronize Alarms](#)” task on [page 8-12](#) as needed.
- Step 7** Complete the “[DLP-G120 View Conditions](#)” task on [page 8-12](#) as needed.

Stop. You have completed this procedure.

DLP-G115 View Alarms

Purpose	Use this task to view current alarms in network, node, or card view.
Tools/Equipment	None
Prerequisite Procedures	DLP-G46 Log into CTC , page 2-25
Required/As Needed	As needed
Onsite/Remote	Onsite or remote
Security Level	Provisioning or higher

- Step 1** In card, node, or network view, click the **Alarms** tab to view the alarms for that card, node, or network. [Table 8-1](#) describes the columns in the Alarms window

Table 8-1 Alarm Column Descriptions

Column	Information Recorded
Num	Sequence number of the original alarm.
Ref	Reference number of the original alarm.
New	Indicates a new alarm; to change this status, click either the Synchronize button or the Delete Cleared Alarms button.
Date	Date and time of the alarm.
Node	(Network view only) The name of the node where the alarm occurred.
Shelf	(Multishelf mode, multishelf view only) The number of the shelf where the alarm occurred.
Object	TL1 access identifier (AID) for the alarmed object; for an STSmon or VTmon, this is the monitored synchronous transport signal (STS) or Virtual Tributary (VT).
Eqpt Type	If an alarm is raised on a card, the card type in this slot.
Slot	If an alarm is raised on a card, the slot where the alarm occurred (appears only in network and node view (single-shelf mode) or shelf view (multishelf view)).
Port	If an alarm is raised on a card, the port where the alarm is raised; for STSTerm and VTTerm, the port refers to the upstream card it is partnered with.
Path Width	Indicates how many STSs are contained in the alarmed path. This information complements the alarm object notation, which is explained in the <i>Cisco ONS 15454 DWDM Troubleshooting Guide</i> .

Table 8-1 Alarm Column Descriptions (continued)

Column	Information Recorded
Sev	Severity level: CR (Critical), MJ (Major), MN (minor), NA (Not Alarmed), NR (Not Reported).
ST	Status: R (raised), C (clear), T (transient).
SA	When checked, indicates a service-affecting alarm.
Cond	The error message/alarm name; these names are alphabetically defined in the <i>Cisco ONS 15454 Troubleshooting DWDM Guide</i> .
Description	Description of the alarm.

Table 8-2 lists the color codes for alarm and condition severities.

Table 8-2 Color Codes for Alarms and Condition Severities

Color	Description
Red	Raised Critical (CR) alarm
Orange	Raised Major (MJ) alarm
Yellow	Raised Minor (MN) alarm
Magenta (pink)	Raised Not Alarmed (NA) condition
Blue	Raised Not Reported (NR) condition
White	Cleared (C) alarm or condition

- Step 2** If alarms are present, refer to the *Cisco ONS 15454 DWDM Troubleshooting Guide* for information and troubleshooting procedures.
- Step 3** Return to your originating procedure (NTP).

DLP-G116 View Alarm or Event History

Purpose	This task is used to view past cleared and uncleared ONS 15454 alarm messages at the card, node, or network level. This task is useful for troubleshooting configuration, traffic, or connectivity issues that are indicated by alarms.
Tools/Equipment	None
Prerequisite Procedures	DLP-G46 Log into CTC, page 2-25
Required/As Needed	As needed
Onsite/Remote	Onsite or remote
Security Level	Retrieve or higher

- Step 1** Decide whether you want to view the alarm message history at the node, network, or card level.

Step 2 To view alarm history for a single-shelf node:

- a. In node view, click the **History > Session** tabs to view the alarms and conditions (events) raised during the current session.
- b. Click the **History > Shelf** tabs.

If you check the **Alarms** check box, the node alarm history appears. If you check the **Events** check box, the node Not Alarmed and transient event history appears. If you check both check boxes, you will retrieve node history for alarms and events.

- c. Click **Retrieve** to view all available messages for the History > Shelf tab.



Note Alarms can be unreported when they are filtered out of the display using the Filter button in either tab. See the [“DLP-G126 Enable Alarm Filtering” task on page 8-26](#) for information.



Tip Double-click an alarm in the alarm table or an event (condition) message in the history table to display the view that corresponds to the alarm message. For example, double-clicking a card alarm takes you to card view. In network view, double-clicking a node alarm takes you to node view.

Step 3 To view alarm history for a multishelf node:

- a. In multishelf view, click the **History > Session** tabs to view the alarms and conditions (events) raised during the current session for the multishelf.
- b. Click the **History > Node** tabs.

If you check the **Alarms** check box, the multishelf alarm history appears. If you check the **Events** check box, the multishelf Not Alarmed and transient event history appears. If you check both check boxes, you will retrieve the multishelf history for alarms and events.

- c. Click **Retrieve** to view all available messages for the History > Node tab.

Step 4 To view node alarm history for a shelf within a multishelf:

- a. In shelf view, click the **History > Session** tabs to view the alarms and conditions (events) raised during the current session for the shelf.
- b. Click the **History > Shelf** tabs.

If you check the **Alarms** check box, the shelf alarm history appears. If you check the **Events** check box, the shelf Not Alarmed and transient event history appears. If you check both check boxes, you will retrieve the shelf node history for alarms and events.

- c. Click **Retrieve** to view all available messages for the History > Shelf tab.

Step 5 To view network alarm history:

- a. From the View menu, choose **Go to Network View**.
- b. Click the **History** tab.

Alarms and conditions (events) raised during the current session appear.

Step 6 To view card alarm history:

- a. From the View menu, choose **Go to Home View**.
- b. If the node is a multishelf, double-click the shelf containing the card you want to view. If it is a single shelf, continue with Step c.

- c. Double-click a card on the shelf graphic to open the card-level view. TCC2/TCC2P cards do not have a card view.
- d. Click the **History** > **Session** tab to view the alarm messages raised during the current session.
- e. Click the **History** > **Card** tab to retrieve all available alarm messages for the card and click **Retrieve**.

If you check the **Alarms** check box, the node's alarm history appears. If you check the **Events** check box, the Not Alarmed and transient event history appears. If you check both boxes, node history for both alarms and events appears.



Note The ONS 15454 can store up to 640 critical alarm messages, 640 major alarm messages, 640 minor alarm messages, and 640 condition messages. When any of these limits is reached, the ONS 15454 discards the oldest events in that category.

Raised and cleared alarm messages (and events, if selected) appear.

Step 7 Return to your originating procedure (NTP).

DLP-G117 Change the Maximum Number of Session Entries for Alarm History

Purpose	This task changes the maximum number of session entries included in the alarm history. Use this task to expand the history list to save information for future reference or troubleshooting.
Tools/Equipment	None
Prerequisite Procedures	DLP-G46 Log into CTC, page 2-25
Required/As Needed	As needed
Onsite/Remote	Onsite or remote
Security Level	Provisioning or higher

Step 1 From the CTC Edit menu, choose **Preferences**.
The CTC Preferences dialog box appears ([Figure 8-3](#)).

Figure 8-3 CTC Preferences Dialog Box

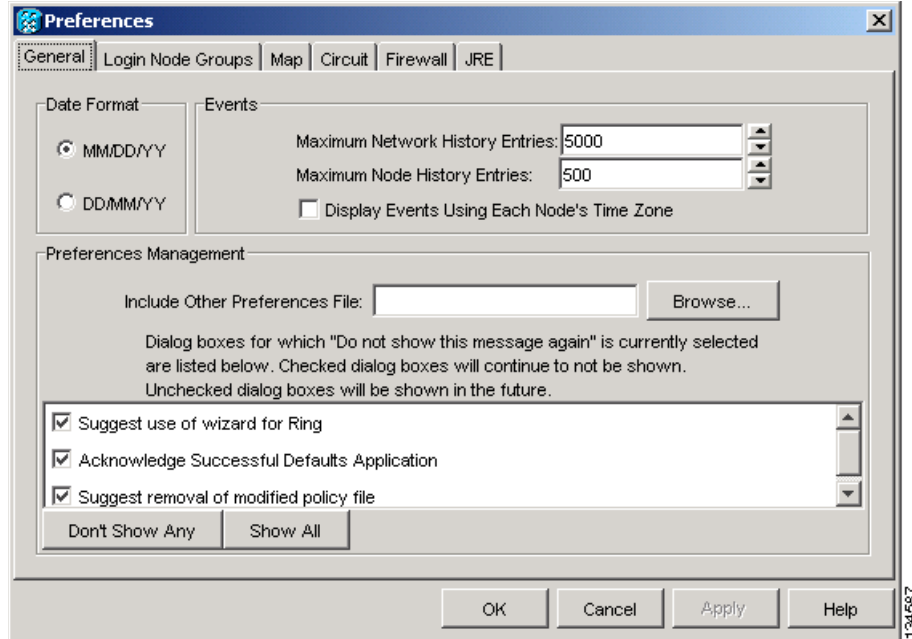

Step 2 Click the up or down arrow buttons next to the Maximum History Entries field to change the entry.

Step 3 Click **Apply** and **OK**.



Note Setting the Maximum History Entries value to the high end of the range uses more CTC memory and could impair CTC performance.



Note This task changes the maximum history entries recorded for CTC sessions. It does not affect the maximum number of history entries viewable for a network, node, or card.

Step 4 Return to your originating procedure (NTP).

DLP-G118 Display Alarms and Conditions Using Time Zone

Purpose	This task changes the time stamp for events to the time zone of the ONS node reporting the alarm. By default, the events time stamp is set to the time zone for the CTC workstation.
Tools/Equipment	None
Prerequisite Procedures	DLP-G46 Log into CTC, page 2-25
Required/As Needed	As needed
Onsite/Remote	Onsite or remote
Security Level	Provisioning or higher

-
- Step 1** From the Edit menu, choose **Preferences**.
The CTC Preferences dialog box appears ([Figure 8-3 on page 8-11](#)).
- Step 2** Check the **Display Events Using Each Node's Time Zone** check box. The Apply button is enabled.
- Step 3** Click **Apply** and **OK**.
- Step 4** Return to your originating procedure (NTP).
-

DLP-G119 Synchronize Alarms

Purpose	This task is used to view ONS 15454 events at the card, node, or network level and to refresh the alarm listing so that you can check for new and cleared alarms and conditions.
Tools/Equipment	None
Prerequisite Procedures	DLP-G46 Log into CTC, page 2-25
Required/As Needed	As needed
Onsite/Remote	Onsite or remote
Security Level	Retrieve or higher

Step 1 At card, node, or network view, click the **Alarms** tab.

Step 2 Click **Synchronize**.

This button causes CTC to retrieve a current alarm summary for the card, node, or network. This step is optional because CTC updates the Alarms window automatically as raise/clear messages arrive from the node.



Note Alarms that have been raised during the session will have a check mark in the Alarms window New column. When you click Synchronize, the check mark disappears.

Step 3 Return to your originating procedure (NTP).

DLP-G120 View Conditions

Purpose	This task is used to view conditions (events with a Not Reported [NR] severity) at the card, node, or network level. Conditions give you a clear record of changes or events that do not result in alarms.
Tools/Equipment	None
Prerequisite Procedures	DLP-G46 Log into CTC, page 2-25
Required/As Needed	As needed
Onsite/Remote	Onsite or remote
Security Level	Retrieve or higher

Step 1 From card, node, or network view, click the **Conditions** tab.

Step 2 Click **Retrieve**.

The Retrieve button requests the current set of fault conditions from the node, card, or network. The window is not updated when events change on the node. You must click Retrieve to see any changes.

Conditions include all fault conditions raised on the node, whether or not they are reported.



Note Alarms can be unreported if they are filtered out of the display. See the [“DLP-G126 Enable Alarm Filtering” task on page 8-26](#) for information.

Events that are reported as Major (MJ), Minor (MN), or Critical (CR) severities are alarms. Events that are reported as Not Alarmed (NA) are conditions. Conditions that are not reported at all are marked Not Reported (NR) in the Conditions window severity column.

Conditions that have a default severity of Critical (CR), Major (MJ), Minor (MN), or Not Alarmed (NA) but are not reported due to exclusion or suppression are shown as NR in the Conditions window.



Note For more information about alarm suppression, see the [“DLP-G129 Suppress Alarm Reporting” task on page 8-29](#).

Current conditions are shown with the severity chosen in the alarm profile, if used. For more information about alarm profiles, see the [“NTP-G68 Create, Download, and Assign Alarm Severity Profiles” procedure on page 8-17](#).



Note When a port is placed in the Out-of-Service and Management, Maintenance (OOS-MA,MT) (ANSI) or Locked-enabled, maintenance (ETSI) service state, it raises an Alarms Suppressed for Maintenance (AS-MT) condition. For information about alarm and condition troubleshooting, refer to the *Cisco ONS 15454 DWDM Troubleshooting Guide*.

Step 3 If you want to apply exclusion rules, check the **Exclude Same Root Cause** check box at the node or network view, but do not check the Exclude Same Root Cause check box in card view.

An exclusion rule eliminates all lower-level alarms or conditions that originate from the same cause. For example, a fiber break might cause a loss of signal (LOS) alarm, an alarm indication signal (AIS) condition, and a signal fail (SF) condition. If you check the Exclude Same Root Cause check box, only the LOS alarm will appear. According to Telcordia, exclusion rules apply to a query of “all conditions from a node.”

Step 4 Return to your originating procedure (NTP).

NTP-G65 Delete Cleared Alarms from Display

Purpose	Use this procedure to delete Cleared (C) status alarms from the Alarms window or transient messages from the CTC History window.
Tools/Equipment	None
Prerequisite Procedures	None
Required/As Needed	As needed
Onsite/Remote	Onsite or remote
Security Level	Retrieve or higher

-
- Step 1** Complete the “[DLP-G46 Log into CTC](#)” task on page 2-25. If you are already logged in, continue with [Step 2](#).
- Step 2** To delete cleared node-level or multishelf-level alarms:
- In node view (single-shelf mode) or multishelf view (multishelf mode), click the **Alarms** tab.
 - Click **Delete Cleared Alarms**.
 - If the Autodelete Cleared Alarms check box is checked, an alarm disappears from the window when it is cleared.
 - If the Autodelete Cleared Alarms check box is not checked, an alarm remains in the window when it is cleared. The alarm appears white in the window and has a Clear (CL) severity. The alarm can be removed by clicking the **Delete Cleared Alarms** button.
- This action removes any cleared ONS 15454 alarms from the Alarms tab. The rows of cleared alarms turn white and have a C in their status (ST) column.
- Step 3** To delete cleared card-level alarms:
- In node view, double-click the card graphic for the card you want to open.
 - Click the **Alarms** tab and then click **Delete Cleared Alarms**.
 - If the Autodelete Cleared Alarms check box is checked, an alarm disappears from the window when it is cleared.
 - If the Autodelete Cleared Alarms check box is not checked, an alarm remains in the window when it is cleared. The alarm appears white in the window and has a Clear (CL) severity. The alarm can be removed by clicking the **Delete Cleared Alarms** button.
- Step 4** To delete cleared network-level alarms:
- In node view, click **View > Go to Network View**.
 - Click the **Alarms** tab and then click **Delete Cleared Alarms**.
 - If the Autodelete Cleared Alarms check box is checked, an alarm disappears from the window when it is cleared.
 - If the Autodelete Cleared Alarms check box is not checked, an alarm remains in the window when it is cleared. The alarm appears white in the window and has a Clear (CL) severity. The alarm can be removed by clicking the **Delete Cleared Alarms** button.
- Step 5** To remove the transient messages from the History window, click **Delete Cleared Alarms**. Transient messages are single messages, not raise-and-clear pairs (that is, they do not have companion messages stating that they are cleared).

Stop. You have completed this procedure.

NTP-G66 View Alarm-Affected Circuits

Purpose	Use this procedure to view all optical channel network connections (OCHNCs) and ONS 15454 circuits, if any, that are affected by an alarm or condition.
Tools/Equipment	None
Prerequisite Procedures	NTP-G64 View Alarms, History, Events, and Conditions, page 8-6
Required/As Needed	As needed
Onsite/Remote	Onsite or remote
Security Level	Retrieve or higher

Step 1 Complete the “[DLP-G46 Log into CTC](#)” task on page 2-25. If you are already logged in, continue with [Step 2](#).

Step 2 In network, node, or card view, click the **Alarms** tab or **Conditions** tab and then right-click anywhere in the row of an active alarm or condition.



Note The node view is the default, but you can also navigate to the Alarms tab in the network view or card view to perform Step 2.

The Select Affected Circuit option appears on the shortcut menu.

Step 3 Left-click or right-click **Select Affected Circuits**.

The **Circuits** window appears with the affected OCHNC highlighted.

Stop. You have completed this procedure.

NTP-G67 View Alarm Counts on the LCD for a Node, Slot, or Port

Purpose	Use this procedure to view an alarm summary for a node, slot, or port without using CTC.
Tools/Equipment	None
Prerequisite Procedures	None
Required/As Needed	As needed
Onsite/Remote	Onsite
Security Level	None

- Step 1** If you want to view the entire alarm summary for the node, press either the **Slot** button or **Port** button on the LCD panel until “Node” appears on the LCD. You will also see the direction, “Status=Alm Ct.” This means that if you press the Status button at this time, as directed in [Step 2](#), you will see an alarm count for the node.
- Step 2** Press the **Status** button to see a summary of alarms and severities for the node. You will see a message similar to “Alm Ct: 2: MJ:2 MN:2,” meaning that there are two critical alarms, two major alarms, and two minor alarms.
- Step 3** If you want to see alarm counts for a particular slot, such as the alarms for an OC-3 card in Slot 3, press the **Slot** button until you see “Slot-3” on the LCD. You will see the direction, “Status=Alm Ct Sum.”
- Step 4** Press the **Status** button to see a summary of alarms and severities against the slot. For example, you might see “Slot-3 Alm Sum:0 MJ:1 MN:2.” This means that there are no critical alarms, one major alarm, and two minor alarms against the slot.
- Step 5** If you want to view the alarms against a port on the card, such as Port 3 of the OC-3 card you viewed previously, press the **Port** button until you see “Port-3 Status=Alm Ct.”
- Step 6** Press **Status** to view alarm count against the port. You will see a message similar to “Slot-3 Port-0 Ct:0 MJ:1 MN:0.” This means that there is one major alarm against this port.

[Figure 8-4](#) shows the shelf LCD panel.

Figure 8-4 Shelf LCD Panel

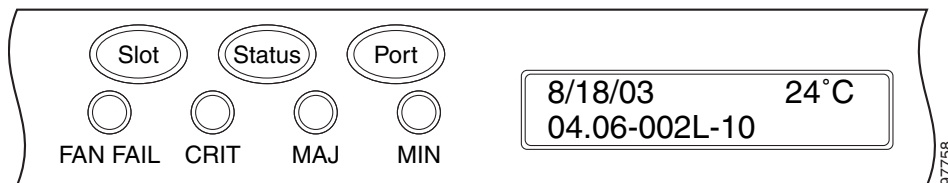

To return to the previous view from the Port screen, continue to press **Port** until the display cycles through all the ports on the slot.

To return to the node menu from the Slot screen, press **Slot** until you cycle through all the slots and see “Node.”

If you do not press any buttons, the LCD will return to its default display with the node name. However, if you did not cycle through the options to return to the node status, you will see the slot or port where you last checked status.



Note A blank LCD results when the fuse on the alarm interface panel (AIP) board has blown. If this occurs, contact the Cisco Technical Assistance Center (TAC). See the [“Obtaining Documentation and Submitting a Service Request”](#) section on page iv.

Stop. You have completed this procedure.

NTP-G68 Create, Download, and Assign Alarm Severity Profiles

Purpose	Use this procedure to create a customized alarm profile at the network, node, or card level. This procedure also provides links to tasks that describe how to assign custom severities individually to each port, card, or node, and to delete alarm profiles.
Tools/Equipment	None
Prerequisite Procedures	None
Required/As Needed	As needed
Onsite/Remote	Onsite or remote
Security Level	Provisioning or higher

-
- Step 1** Complete the “[DLP-G46 Log into CTC](#)” task on page 2-25 at the node where you want to create an alarm profile. If you are already logged in, continue with [Step 2](#) to create, clone, or modify an alarm profile, or go to [Step 3](#) to download an alarm profile.
- Step 2** Complete the “[DLP-G121 Create a New or Cloned Alarm Severity Profile](#)” task on page 8-17. This task clones a current alarm profile, renames the profile, and customizes the new profile.
- Step 3** Complete the “[DLP-G122 Download an Alarm Severity Profile](#)” task on page 8-20. This task downloads an alarm severity profile from a CD or a node.



Note After storing a created or downloaded alarm profile, you must go to the node (either by logging into it or clicking on it from the network view) and activate the profile by applying it to the shelf, one or more cards, or one or more ports.

-
- Step 4** As necessary, complete the “[DLP-G123 Apply Alarm Profiles to Ports](#)” task on page 8-21 or the “[DLP-G124 Apply Alarm Profiles to Cards and Nodes](#)” task on page 8-23.
- Step 5** As necessary, complete the “[DLP-G125 Delete Alarm Severity Profiles](#)” task on page 8-23.

Stop. You have completed this procedure.

DLP-G121 Create a New or Cloned Alarm Severity Profile

Purpose	This task creates a custom severity profile or clones and modifies the default severity profile.
Tools/Equipment	None
Prerequisite Procedures	DLP-G46 Log into CTC , page 2-25
Required/As Needed	As needed
Onsite/Remote	Onsite or remote
Security Level	Provisioning or higher

-
- Step 1** From the CTC window View menu, select **Go To Network View**.
- Step 2** To access the alarm profile editor from network view, click the **Provisioning > Alarm Profiles** tabs.



Note To access the profile editor from node view (single-shelf mode) or shelf view (multishelf mode), or card view, click the **Provisioning > Alarm Profiles > Alarm Profile Editor** tabs.

Step 3 If you want to create a new profile based on the default profile in use, click **New**. Continue with [Step 9](#).

Step 4 If you want to create a profile using an existing profile located on the node, click **Load** and **From Node** in the Load Profiles dialog box.

- a. Click the node name you are logged into in the Node Names list.
- b. Click the name of an existing profile in the Profile Names list, such as **Default**. Continue with [Step 6](#).

Step 5 If you want to create a profile using an existing profile located in a file that is stored locally or on a network drive, click **From File** in the Load Profiles dialog box.

- a. Click **Browse**.
- b. Navigate to the file location in the **Open** dialog box.
- c. Click **Open**.



Note All default or user-defined severity settings that are Critical (CR) or Major (MJ) are demoted to Minor (MN) in Non-Service-Affecting (NSA) situations as defined in Telcordia GR-474-CORE.

Step 6 Click **OK**.

The alarm severity profile appears in the Alarm Profiles window. The alarm profile list contains a master list of alarms that is used for a mixed node network. Some of these alarms might not be used in all ONS nodes.

Step 7 Right-click anywhere in the profile column to view the profile editing shortcut menu. (Refer to [Step 10](#) for further information about the Default profile.)

Step 8 Click **Clone** in the shortcut menu.



Tip To see the full list of profiles, including those available for loading or cloning, click Available. You must load a profile before you can clone it.

Step 9 In the New Profile dialog box, enter a name in the New Profile Name field.

Profile names must be unique. If you try to import or name a profile that has the same name as another profile, CTC adds a suffix to create a new name. Long file names are supported.

Step 10 Click **OK**.

A new alarm profile (named in [Step 9](#)) is created. (If this is the first alarm profile created during installation, the default alarm profile settings are displayed in the AlarmType::Condition column on the left.) This profile duplicates the default profile severities and appears at the right of the previous profile column in the Alarm Profiles window. You can select it and drag it to a different position.



Note Up to ten profiles, including the two reserved profiles, Inherited and Default, can be stored in CTC.

The Default profile sets severities to standard Telcordia GR-474-CORE settings. If an alarm has an Inherited profile, it inherits (copies) its severity from the same alarm's severity at the higher level. For example, if you choose the Inherited profile from the network view, the severities at the lower levels (node, card, and port) will be copied from this selection. A card with an Inherited alarm profile copies the severities used by the node that contains the card. (If you are creating profiles, you can apply these separately at any level. To do this, refer to the “DLP-G124 Apply Alarm Profiles to Cards and Nodes” task on page 8-23.)

- Step 11** Modify (customize) the new alarm profile:
- a. In the new alarm profile column, click the alarm severity you want to change in the custom profile.
 - b. Choose a severity from the drop-down list.
 - c. Repeat Steps a and b for each severity you want to customize. Refer to the following guidelines when you view the alarms or conditions after making modifications:
 - All Critical (CR) or Major (MJ) default or user-defined severity settings are demoted to Minor (MN) in Non-Service-Affecting (NSA) situations as defined in Telcordia GR-474-CORE.
 - Default severities are used for all alarms and conditions until you create and apply a new profile.
 - Changing a severity to inherited (I) or unset (U) does not change the severity of the alarm.
- Step 12** After you have customized the new alarm profile, right-click the profile column to highlight it.
- Step 13** Click **Store**.
- Step 14** In the Store Profiles dialog box (Figure 8-5), click **To Node(s)** and go to Step a, or click **To File** and go to Step b.

Figure 8-5 Store Profiles Dialog Box

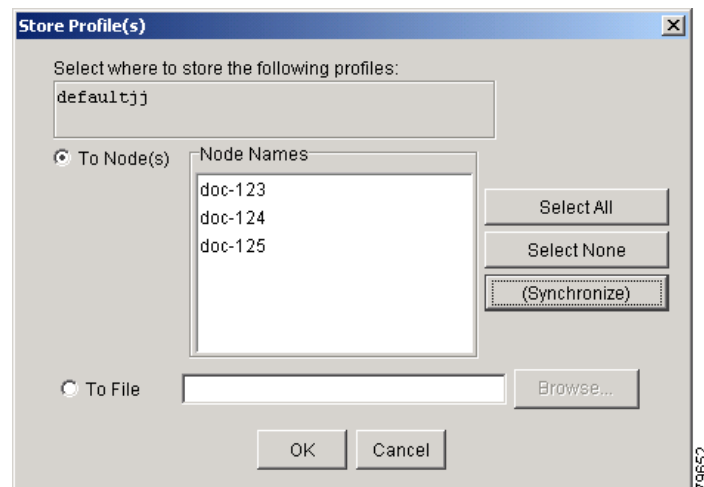

- a. Choose the node where you want to save the profile:
 - If you want to save the profile to only one node, click the node in the Node Names list.
 - If you want to save the profile to all nodes, click **Select All**.
 - Press the Ctrl key, and simultaneously left-click the node where the profile is to be saved.
 - If you do not want to save the profile to any nodes, click **Select None**.
 - If you want to update alarm profile information, click **(Synchronize)**.

- Click **OK** to save the profile.
- b.** Save the profile:
- Click **Browse** and navigate to the profile save location.
 - Enter a name in the File name field.
 - Click **Select** to choose this name and location. Long file names are supported. CTC supplies a suffix of *.pfl to stored files.
 - Click **OK** to store the profile.
- Step 15** As needed, perform any of the following actions. The following options are located at the bottom of the **Provisioning > Alarm Profile** window.
- Click the **Hide Identical Rows** check box to configure the Alarm Profiles window to view rows with dissimilar severities.
 - Click the **Hide Reference Values** check box to configure the Alarm Profiles window to view severities that do not match the Default profile.
 - Click the **Only show service-affecting severities** check box to configure the Alarm Profiles window not to display Minor and some Major alarms that will not affect service.
- Step 16** Return to your originating procedure (NTP).

DLP-G122 Download an Alarm Severity Profile

Purpose	This task downloads a custom alarm severity profile from a network-drive-accessible CD-ROM, floppy disk, or hard disk location.
Tools/Equipment	None
Prerequisite Procedures	DLP-G46 Log into CTC, page 2-25
Required/As Needed	As needed
Onsite/Remote	Onsite or remote
Security Level	Provisioning or higher



Note

You must always store the alarm profile after editing it. If you edit an alarm profile without saving it, changes to the profile will be lost if you change views in CTC.

- Step 1** To access the alarm profile editor from network view, click the **Provisioning > Alarm Profiles** tabs.



Note

To access the profile editor from node view (single-shelf mode) or shelf view (multishelf mode), or card view, click the **Provisioning > Alarm Profiles > Alarm Profile Editor** tabs.

- Step 2** Click **Load**.

- Step 3** If you want to download a profile that exists on the node, click **From Node** in the Load Profiles dialog box.

- a.** Click the node name you are logged into in the Node Names list.
- b.** Click the name of the profile in the Profile Names list, such as **Default**.

c. Click **OK**.

Step 4 If you want to download a profile that is stored locally or on a network drive, click **From File** in the Load Profile dialog box.

a. Click **Browse**.

b. Navigate to the file location in the **Open** dialog box.

c. Click **Open**.



Note All default or user-defined severity settings that are Critical (CR) or Major (MJ) are demoted to Minor (MN) in Non-Service-Affecting (NSA) situations as defined in Telcordia GR-474.

Step 5 Click **OK**.

The downloaded profile appears at the right side of the Alarm Profiles window.

Step 6 Right-click anywhere in the downloaded profile column to view the profile editing shortcut menu.

Step 7 Click **Store**.

Step 8 In the Store Profiles dialog box, click **To Node(s)**.

a. Choose the nodes where you want to save the profile:

- If you want to save the profile to only one node, click the node in the Node Names list.
- If you want to save the profile to all nodes, click **Select All**.
- Press the Ctrl key, and simultaneously left-click the node where the profile is to be saved.
- If you do not want to save the profile to any nodes, click **Select None**.
- If you want to update alarm profile information, click **Synchronize**.

b. Click **OK**.

Step 9 Return to your originating procedure (NTP).

DLP-G123 Apply Alarm Profiles to Ports

Purpose	This task applies a custom or default alarm severity profile to a port or ports.
Tools/Equipment	None
Prerequisite Procedures	DLP-G121 Create a New or Cloned Alarm Severity Profile, page 8-17 DLP-G46 Log into CTC, page 2-25
Required/As Needed	As needed
Onsite/Remote	Onsite or remote
Security Level	Provisioning or higher



Note You can also apply alarm profiles to cards using the [“DLP-G124 Apply Alarm Profiles to Cards and Nodes” task on page 8-23](#).

- Step 1** In node view (single-shelf mode) or shelf view (multishelf mode), double-click the card that you want to change to open the card view.



Note The card view is not available for the TCC2/TCC2P card.

- Step 2** Click the **Provisioning > Alarm Profiles > Alarm Behavior** tabs.

Figure 8-6 shows alarm profiles for the AD-1C card, for example. CTC shows Parent Card Profile: Inherited.

Figure 8-6 AD-1C Card Alarm Profile

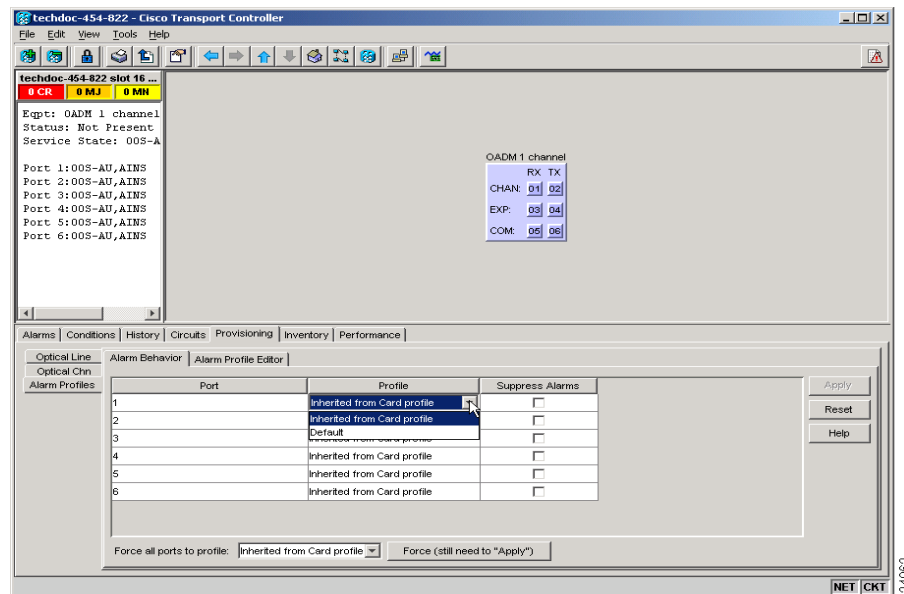

Go to [Step 3](#) to apply profiles to a port. Go to [Step 4](#) to apply profiles to all ports on a card.

- Step 3** To apply profiles on a port basis:
- In card view, click the port row in the Profile column.
 - Choose the new profile from the drop-down list.
 - Click **Apply**. Confirm the profile updated to the port correctly.
- Step 4** To apply profiles to all ports on a card:
- In card view, click the **Force all ports to profile** drop-down arrow at the bottom of the window.
 - Choose the new profile from the drop-down list.
 - Click **Force (still need to “Apply”)**.
 - Click **Apply**. Confirm that the profile updated to all ports correctly.

In node view, the Port Level Profiles column indicates port-level profiles with a notation such as “exist (1)”.

- Step 5** To reapply a previous alarm profile after you have applied a new one, select the previous profile and click **Apply** again.

Step 6 Return to your originating procedure (NTP).

DLP-G124 Apply Alarm Profiles to Cards and Nodes

Purpose	This task applies a custom or default alarm profile to cards or nodes.
Tools/Equipment	None
Prerequisite Procedures	DLP-G121 Create a New or Cloned Alarm Severity Profile, page 8-17 DLP-G46 Log into CTC, page 2-25
Required/As Needed	As needed
Onsite/Remote	Onsite or remote
Security Level	Provisioning or higher

- Step 1** In node view (single-shelf mode) or shelf view (multishelf mode), click the **Provisioning > Alarm Profiles > Alarm Behavior** tab.
- Step 2** To apply profiles to a card:
- Click a selection from the Profile column for the card.
 - Choose the new profile from the drop-down list.
 - Click **Apply**.
- Step 3** To apply the profile to an entire node:
- Click the **Force All Ports to Profile** drop-down arrow at the bottom of the window.
 - Choose the new alarm profile from the drop-down list.
 - Click **Force (still need to apply)**.
- Step 4** Click **Apply** again.
- Step 5** Return to your originating procedure (NTP).
-

DLP-G125 Delete Alarm Severity Profiles

Purpose	This task deletes a custom or default alarm severity profile.
Tools/Equipment	None
Prerequisite Procedures	DLP-G46 Log into CTC, page 2-25
Required/As Needed	As needed
Onsite/Remote	Onsite or remote
Security Level	Provisioning or higher

- Step 1** To access the alarm profile editor from network view, click the **Provisioning > Alarm Profiles** tabs.



Note To access the profile editor from node or card view, click the **Provisioning > Alarm Profiles > Alarm Profile Editor** tabs.

Step 2 Click the profile that you want to delete. (Click the column that displays the profile name to select it.)

Step 3 Click **Delete**.

The Select Node/Profile Combination for Delete dialog box appears (Figure 8-7).

Figure 8-7 Select Node/Profile Combination For Delete Dialog Box

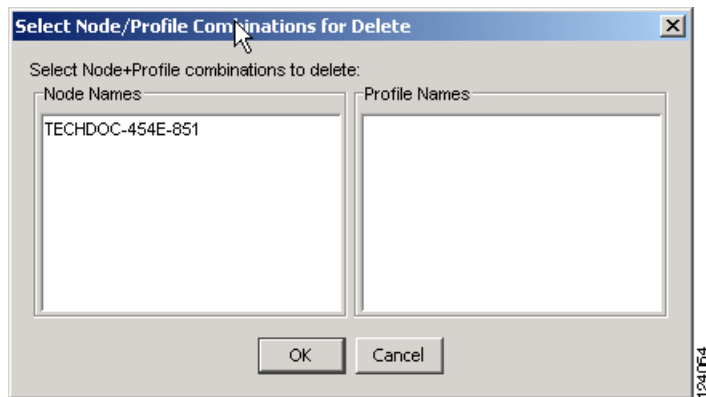

Note You cannot delete the Inherited or Default alarm profiles.



Note A previously created alarm profile cannot be deleted unless it has been stored on the node. If the profile is visible on the Alarm Profiles tab but is not listed in the Select Node/Profile Combinations to Delete dialog box, continue with [Step 8](#).

Step 4 Click the node name in the Node Names list to highlight the profile location.



Tip If you hold the Shift key down, you can select consecutive node names. If you hold the Ctrl key down, you can select any combination of nodes.

Step 5 Click the profile names that you want to delete in the Profile Names list.

Step 6 Click **OK**.

Step 7 Click **Yes** in the Delete Alarm Profile dialog box.

If you delete a profile from a node, it still appears in the network view Provisioning > Alarm Profile Editor window unless you remove it using the following step.

Step 8 To remove the alarm profile from the window, right-click the column of the profile that you deleted and choose **Remove** from the shortcut menu.

If a node and profile combination is selected but does not exist, a warning appears: “One or more of the profiles selected do not exist on one or more of the node(s) selected.” For example, if Node A has only Profile 1 stored and the user tries to delete both Profile 1 and Profile 2 from Node A, this warning appears. However, the operation still removes Profile 1 from Node A.

The Default and Inherited special profiles cannot be deleted and do not appear in the Select Node/Profile Combination for Delete window.

- Step 9** Return to your originating procedure (NTP).
-

NTP-G69 Enable, Modify, or Disable Alarm Severity Filtering

Purpose	Use this procedure to start, change, or stop alarm filtering for one or more severities in the Alarms, Conditions, and History windows in all network nodes.
Tools/Equipment	None
Prerequisite Procedures	None
Required/As Needed	As needed
Onsite/Remote	Onsite or remote
Security Level	Retrieve or higher

- Step 1** Complete the “[DLP-G46 Log into CTC](#)” task on page 2-25 at the node where you want to enable alarm severity filtering. If you are already logged in, continue with [Step 2](#).
- Step 2** As needed, complete the “[DLP-G126 Enable Alarm Filtering](#)” task on page 8-26. This task enables alarm filtering at the card, node, and network views for all nodes in the network. Alarm filtering can be enabled for alarms, conditions, or events.
- Step 3** As needed, complete the “[DLP-G127 Modify Alarm, Condition, and History Filtering Parameters](#)” task on page 8-26 to modify the alarm filtering for network nodes to show or hide particular alarms or conditions.
- Step 4** As needed, complete the “[DLP-G128 Disable Alarm Filtering](#)” task on page 8-28 to disable alarm profile filtering for all network nodes.

Stop. You have completed this procedure.

DLP-G126 Enable Alarm Filtering

Purpose	This task enables alarm filtering for alarms, conditions, or event history in all network nodes.
Tools/Equipment	None
Prerequisite Procedures	DLP-G46 Log into CTC, page 2-25
Required/As Needed	As needed
Onsite/Remote	Onsite or remote
Security Level	Retrieve or higher

-
- Step 1** At node, network, or card view, click the **Alarms** tab.
- Step 2** Click the **Filter** tool icon on the right side of the bottom toolbar.



Note The Filter tool icon differs from the Filter button at the bottom left of the screen.

Alarm filtering is enabled if the tool is selected and disabled if the tool is raised (not selected).

Alarm filtering is enabled in the card, node, and network views of the same window for all nodes in the network. For example, if the Filter tool is enabled in the node view Alarms window, the network view Alarms window and card view Alarms window also show the tool enabled.

- Step 3** If you want alarm filtering enabled when you view conditions, repeat Steps 1 and 2 using the Conditions window.
- Step 4** If you want alarm filtering enabled when you view alarm history, repeat Steps 1 and 2 using the History window.
- Step 5** Return to your originating procedure (NTP).
-

DLP-G127 Modify Alarm, Condition, and History Filtering Parameters

Purpose	This task changes alarm and condition reporting in all network nodes.
Tools/Equipment	None
Prerequisite Procedures	DLP-G126 Enable Alarm Filtering, page 8-26 DLP-G46 Log into CTC, page 2-25
Required/As Needed	As needed
Onsite/Remote	Onsite or remote
Security Level	Retrieve or higher

-
- Step 1** At node, network, or card view, click the **Alarms** tab, **Conditions** tab, or **History** tab.
- Step 2** Click the **Filter** button on the left side of the bottom toolbar.
- The filter dialog box appears, displaying the General tab. [Figure 8-8](#) shows the Alarm Filter dialog box; the Conditions and History tabs have similar dialog boxes.

Figure 8-8 Alarm Filter Dialog Box General Tab

In the General tab Show Severity area, you can choose which alarm severities will show through the alarm filter and provision a time period during which filtered alarms show through the filter. To change the alarm severities shown in the filter, go to [Step 3](#). To change the time period filter for the alarms, go to [Step 4](#).

- Step 3** In the Show Severity area, click the check boxes for the severities [Critical (CR), Major (MJ), Minor (MN), or Not Alarmed (NA)] that you want to be reported at the network level. Leave severity check boxes deselected (unchecked) to prevent those severities from appearing.

When alarm filtering is disabled, all alarms show.

- Step 4** In the Time area, click the **Show alarms between time limits** check box to enable it. Click the up and down arrows in the From Date, To Date, and Time fields to modify the period of alarms that is shown.

To modify filter parameters for conditions, continue with [Step 5](#). If you do not need to modify them, continue with [Step 6](#).

- Step 5** Click the filter dialog box **Conditions** tab ([Figure 8-9](#)).

Figure 8-9 Alarm Filter Dialog Box Conditions Tab

When filtering is enabled, conditions in the Show list are visible and conditions in the Hide list are invisible.

- To move conditions individually from the Show list to the Hide list, click the > button.
- To move conditions individually from the Hide list to the Show list, click the < button.
- To move conditions collectively from the Show list to the Hide list, click the >> button.
- To move conditions collectively from the Hide list to the Show list, click the << button.



Note Conditions include alarms.

Step 6 Click **Apply** and **OK**.

Alarm and condition filtering parameters are enforced when alarm filtering is enabled (see the “[DLP-G126 Enable Alarm Filtering](#)” task on page 8-26), and the parameters are not enforced when alarm filtering is disabled (see the “[DLP-G128 Disable Alarm Filtering](#)” task on page 8-28).

Step 7 Return to your originating procedure (NTP).

DLP-G128 Disable Alarm Filtering

Purpose	This task turns off specialized alarm filtering in all network nodes so that all severities are reported in CTC.
Tools/Equipment	None
Prerequisite Procedures	DLP-G126 Enable Alarm Filtering , page 8-26 DLP-G46 Log into CTC , page 2-25
Required/As Needed	As needed
Onsite/Remote	Onsite or remote
Security Level	Retrieve or higher

Step 1 At node, network, or card view, click the **Alarms** tab.

Step 2 Click the **Filter** tool icon on the right side of the bottom toolbar.



Note The Filter tool icon differs from the Filter button at the bottom left of the screen.

Alarm filtering is enabled if the tool is indented (the filter icon is blue) and disabled if the tool is raised (not selected; the filter icon is white).

Step 3 If you want alarm filtering disabled when you view conditions, click the **Conditions** tab and click the Filter tool.

Step 4 If you want alarm filtering disabled when you view alarm history, click the **History** tab and click the Filter tool.

Step 5 Return to your originating procedure (NTP).

NTP-G70 Suppress Alarms or Discontinue Alarm Suppression

Purpose	Use this procedure to prevent alarms from being reported for a port, card, or node in circumstances when an alarm or condition is known to exist but you do not want to include it in the Alarms or History display. This procedure also provides a link to a task that explains how to resume normal alarm reporting by discontinuing the suppression.
Tools/Equipment	None
Prerequisite Procedures	None
Required/As Needed	As needed
Onsite/Remote	Onsite or remote
Security Level	Provisioning or higher

Step 1 Complete the [“DLP-G46 Log into CTC” task on page 2-25](#). If you are already logged in, continue with [Step 2](#).

Step 2 Complete the [“DLP-G129 Suppress Alarm Reporting” task on page 8-29](#) to enable the node to send autonomous messages that clear specific raised alarms and cause suppressed alarms to appear in the Conditions window.

Suppressing one or more alarms prevents them from appearing in Alarm or History windows or in any other clients. The suppress command causes CTC to display them in the Conditions window with their severity, their severity color code, and their service-affecting status.

Step 3 Complete the [“DLP-G130 Discontinue Alarm Suppression” task on page 8-31](#) to discontinue alarm suppression and resume normal alarm reporting.

Stop. You have completed this procedure.

DLP-G129 Suppress Alarm Reporting

Purpose	This task suppresses the reporting of ONS 15454 alarms at the node, card, or port level.
Tools/Equipment	None
Prerequisite Procedures	DLP-G46 Log into CTC, page 2-25
Required/As Needed	As needed
Onsite/Remote	Onsite or remote
Security Level	Provisioning or higher



Caution

If multiple CTC/TL1 sessions are open, suppressing alarms in one session suppresses the alarms in all other open sessions.

**Note**

Alarm suppression at the node level does not supersede alarm suppression at the card or port level. Suppression can exist independently for all three entities, and each entity will raise separate alarms suppressed by the user command (AS-CMD) alarm.

Step 1 If you are in node view, click the **Provisioning > Alarm Profiles > Alarm Behavior** tabs.

Step 2 To suppress alarms for the entire node:

- a. Check the **Suppress Alarms** check box.
- b. Click **Apply**.

All raised alarms for the node will change color to white in the Alarms window and their status will change to cleared. After suppressing alarms, clicking **Synchronize** in the Alarms window will remove cleared alarms from the window. However, an AS-CMD alarm will show in node or card view to indicate that node-level alarms were suppressed, and the word System will appear in the Object column.

**Note**

The only way to suppress building integrated timing supply (BITS), power source, or system alarms is to suppress alarms for the entire node. These cannot be suppressed separately.

Step 3 To suppress alarms for individual cards:

- a. In the alarm behavior window, locate the card row (using the Location column for the slot number or the Eqpt Type column for the equipment name).
- b. Check the **Suppress Alarms** column check box in that row.

Alarms that directly apply to this card will change appearance as described in [Step 2](#). For example, if you suppressed raised alarms for an OC-48 card in Slot 16, raised alarms for this card will change in node or card view. The AS-CMD alarm will show the slot number in the Object number. For example, if you suppressed alarms for a Slot 16 OC-48 card, the AS-CMD object will be "SLOT-16."

Click **Apply**.

Step 4 To suppress alarms for individual card ports, double-click the card in node view.

Step 5 Click the **Provisioning > Alarm Profiles > Alarm Behavior** tabs.

Step 6 Check the **Suppress Alarms** column check box for the port row where you want to suppress alarms ([Figure 8-6 on page 8-22](#)).

Step 7 Click **Apply**.

Alarms that apply directly to this port will change appearance as described in [Step 2](#). (However, alarms raised on the entire card will remain raised.) A raised AS-CMD alarm that shows the port as its object will appear in either alarm window. For example, if you suppressed alarms for Port 1 on the Slot 16 OC-48 card, the alarm object will show "FAC-16-1."

Step 8 Return to your originating procedure (NTP).

DLP-G130 Discontinue Alarm Suppression

Purpose	This task discontinues alarm suppression and reenables alarm reporting on a port, card, or node.
Tools/Equipment	None
Prerequisite Procedures	DLP-G129 Suppress Alarm Reporting, page 8-29 DLP-G46 Log into CTC, page 2-25
Required/As Needed	As needed
Onsite/Remote	Onsite or remote
Security Level	Provisioning or higher



Caution

If multiple CTC sessions are open, discontinuing suppression in one session will discontinue suppression in all other open sessions.

-
- Step 1** To discontinue alarm suppression for the entire node:
- In node view, click the **Provisioning > Alarm Profiles > Alarm Behavior** tab.
 - Uncheck the **Suppress Alarms** check box.
- Suppressed alarms will reappear in the Alarms window. (They might have previously been cleared from the window using the Synchronize button.) The AS-CMD alarm with the System object will be cleared in all views.
- Step 2** To discontinue alarm suppression for individual cards:
- In node view, click the **Provisioning > Alarm Profiles > Alarm Behavior** tabs.
 - Locate the card that is suppressed in the slot list.
 - Uncheck the Suppress Alarms column check box for that slot.
 - Click **Apply**.
- Suppressed alarms will reappear in the Alarms window. (They might have previously been cleared from the window using the Synchronize button.) The AS-CMD alarm with the slot object (for example, SLOT-16) will be cleared in all views.
- Step 3** To discontinue alarm suppression for ports, click the **Provisioning > Alarm Profiles > Alarm Behavior** tabs.
- Step 4** Uncheck the **Suppress Alarms** check box for the port(s) that you no longer want to suppress.
- Step 5** Click **Apply**.
- Suppressed alarms will reappear in the Alarms window. (They might have previously been cleared from the window using the Synchronize button.) The AS-CMD alarm with the port object (for example, FAC-16-1) will be cleared in all views.
- Step 6** Return to your originating procedure (NTP).
-

NTP-G72 Provision External Alarms and Controls on the Alarm Interface Controller-International Card

Purpose	Use this procedure to create external (environmental) alarms and external controls for the AIC-I card.
Tools/Equipment	An AIC-I card must be installed in Slot 9.
Prerequisite Procedures	DLP-G34 Install the AIC-I Card, page 1-76
Required/As Needed	As needed
Onsite/Remote	Onsite or remote
Security Level	Provisioning or higher



Note

On the ONS 15454 ANSI shelf, the AIC-I card alarm provides direct alarm contacts (external alarm inputs and external control outputs) routed through the backplane to wire-wrap pins accessible from the back of the shelf. If you install an Alarm Expansion Panel (AEP), the AIC-I alarm contacts cannot be used. Only the AEP alarm contacts can be used. For further information about the AEP, see [“NTP-G9 Install the Alarm Expansion Panel \(ANSI Only\)” procedure on page 1-43](#) and the [“NTP-G11 Install an External Wire-Wrap Panel on the AEP \(ANSI Only\)” procedure on page 1-57](#). The ONS 15454 ETSI shelf is not compatible with the AEP.



Note

For information about the AIC-I external alarms, external controls, and virtual wire, refer to the “Alarm Monitoring and Management” chapter in the *Cisco ONS 15454 DWDM Reference Manual*.

- Step 1** If you are using an ONS 15454 ANSI shelf, verify the backplane wiring. If you are using the AEP, see the [“NTP-G9 Install the Alarm Expansion Panel \(ANSI Only\)” procedure on page 1-43](#). Otherwise, see the [“NTP-G10 Attach Wires to Alarm, Timing, LAN, and Craft Pin Connections” procedure on page 1-46](#) for information about the ONS 15454 backplane pins.
- For external alarms, verify that the external device relays are wired to the ENVIR ALARMS IN backplane pins.
 - For external controls, verify that the external device relays are wired to the ENVIR ALARMS OUT backplane pins.
- Step 2** If you are using an ONS 15454 ETSI shelf, verify the alarm contact wiring. See the [“NTP-G10 Attach Wires to Alarm, Timing, LAN, and Craft Pin Connections” procedure on page 1-46](#) for information about the ONS 15454 SDH contacts.
- For external alarms, verify that the external device relays are wired to the ENVIR ALARMS IN connector pins.
 - For external controls, verify the external device relays are wired to the ENVIR ALARMS OUT connector pins.
- Step 3** Complete the [“DLP-G46 Log into CTC” task on page 2-25](#). If you are already logged in, continue with [Step 4](#).
- Step 4** In node view, double-click the AIC-I card on the shelf graphic. The card view appears.
- Step 5** Click the **Provisioning > Card** tabs.

- Step 6** In the Alarm Contacts area, click the **Add Extension** radio button if you are using the AEP. Clicking this option will choose the External Alarm input/output type and the AEP extension type; it will give you access to 16 external alarm contacts.
- Step 7** If you did not click Add Extension, in the Input/Output area choose either External Alarm or External Control. (External Alarm will limit your input/output options as explained in [Step 6](#).) Choosing External Control will enable both external alarms and external controls. This will convert four of the external alarm contacts to external controls, leaving 12 available external control contacts. The extension type for both options is AEP.
- Step 8** If you are provisioning external alarms, click the **External Alarms** tab ([Figure 8-10](#)). If you are not provisioning external alarms, skip [Steps 9](#) through [11](#) and go to [Step 12](#).

Figure 8-10 Provisioning External Alarms on the AIC-I Card

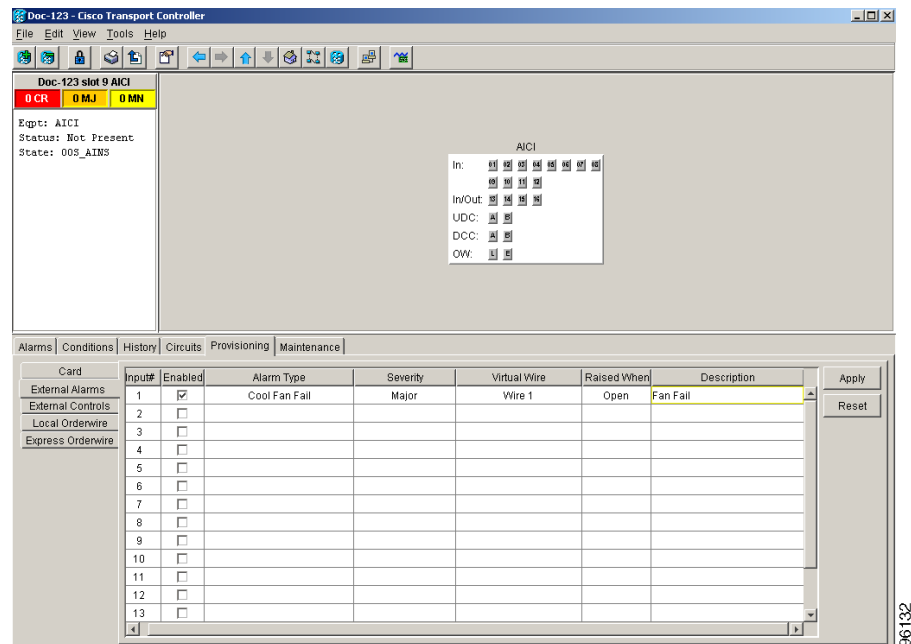

- Step 9** For external alarms, complete the following fields:
- **Enabled**—Check the check box to activate the fields for the alarm input number.
 - **Alarm Type**—Choose an alarm type from the drop-down list.
 - **Severity**—Choose a severity from the drop-down list.
- The severity determines the alarm's severity in the Alarms and History tabs and determines whether the LEDs are activated. Critical (CR), Major (MJ), and Minor (MN) alarms activate the LEDs. Not Alarmed (NA) and Not Reported (NR) events do not activate LEDs, but do report the information in CTC.
- **Virtual Wire**—Choose the virtual wire number from the drop-down list if you want to assign the external device to a virtual wire. Otherwise, do not change the None default.
 - **Raised When**—From the drop-down list, choose the contact condition (open or closed) that triggers the alarm.
 - **Description**—A default description is provided; enter a different description if needed. (Double-click the cell and highlight the text to change it.)

Step 10 To provision additional devices, complete [Step 9](#) for each additional device.

Step 11 Click **Apply**.

When you provision an external alarm, the alarm object is ENV-IN-*nn*. The variable *nn* refers to the external alarm's number, regardless of the name you assign.

Step 12 For external controls, click the **External Controls** tab and complete the following fields for each control wired to the ONS 15454 backplane (ANSI) or FMEC connector pins (ETSI):

- **Enabled**—Check this check box to activate the fields for the alarm input number.
- **Control Type**—Choose the control type from the drop-down list: air conditioner, engine, fan, generator, heat, light, sprinkler, or miscellaneous.
- **Trigger Type**—Choose a trigger type: a local minor, major, or critical alarm; a remote minor, major, or critical alarm; or a virtual wire activation.
- **Description**—Enter a description. (Double-click on the cell and highlight the text to change it.)

Step 13 To provision additional external controls, complete [Step 12](#) for each device.

Step 14 Click **Apply**.



Note External alarms and controls should be recorded locally for the network element (NE). Both the alarm name and resolution are node-specific.

Stop. You have completed this procedure.



Monitor Performance

This chapter explains how to enable and view performance monitoring (PM) statistics for the Cisco ONS 15454. PM parameters are used by service providers to gather, store, set thresholds, and report performance data for early detection of problems. For more PM information, details, and definitions, refer to the *Cisco ONS 15454 DWDM Reference Manual*.



Note

Unless otherwise specified, “ONS 15454” refers to both ANSI and ETSI shelf assemblies.

Before You Begin

Before performing any of the following procedures, investigate all alarms and clear any trouble conditions. Refer to the *Cisco ONS 15454 DWDM Troubleshooting Guide* as necessary.

This section lists the chapter procedures (NTPs). Turn to a procedure for applicable tasks (DLPs).

1. [NTP-G73 Change the PM Display, page 9-2](#)—Complete as needed to change the displayed PM counts.
2. [NTP-G74 Monitor DWDM Card Performance, page 9-9](#)—Complete as needed to monitor dense wavelength division multiplexing (DWDM) performance.
3. [NTP-G75 Monitor Transponder and Muxponder Performance, page 9-19](#)—Complete as needed to monitor transponder (TXP) and muxponder (MXP) card performance.



Note

For additional information regarding PM parameters, refer to Telcordia GR-499-CORE, GR-253-CORE, GR-820-CORE (titled *Generic Digital Transmission Surveillance*), and GR-1230-CORE, and to the ANSI T1.231 document titled *Digital Hierarchy - Layer 1 In-Service Digital Transmission Performance Monitoring*.

NTP-G73 Change the PM Display

Purpose	This procedure enables you to change the display of PM counts by selecting drop-down list or radio button options in the Performance window.
Tools/Equipment	None
Prerequisite Procedures	Before you monitor performance, be sure you have created the appropriate circuits and provisioned the card according to your specifications. For more information, see Chapter 7, “Create Channels and Circuits,” Chapter 5, “Provision Transponder and Muxponder Cards,” and Chapter 11, “Change DWDM Card Settings.”
Required/As Needed	As needed
Onsite/Remote	Onsite or remote
Security Level	Retrieve or higher

Step 1 Complete the “[DLP-G46 Log into CTC](#)” task on [page 2-25](#) at the node that you want to monitor. If you are already logged in, continue with [Step 2](#).

Step 2 As needed, use the following tasks to change the display of PM counts:



- [DLP-G131 Refresh PM Counts at 15-Minute Intervals, page 9-2](#)
- [DLP-G132 Refresh PM Counts at One-Day Intervals, page 9-3](#)
- [DLP-G133 View Near-End PM Counts, page 9-4](#)
- [DLP-G134 View Far-End PM Counts, page 9-5](#)
- [DLP-G135 Reset Current PM Counts, page 9-6](#)
- [DLP-G136 Clear Selected PM Counts, page 9-7](#)
- [DLP-G137 Set Auto-Refresh Interval for Displayed PM Counts, page 9-8](#)
- [DLP-G138 Refresh PM Counts for a Different Port, page 9-9](#)

Stop. You have completed this procedure.

DLP-G131 Refresh PM Counts at 15-Minute Intervals

Purpose	This task changes the window view to display PM counts in 15-minute intervals.
Tools/Equipment	None
Prerequisite Procedures	DLP-G46 Log into CTC, page 2-25
Required/As Needed	As needed
Onsite/Remote	Onsite or remote
Security Level	Retrieve or higher

Step 1 In node view (single-shelf mode), or shelf view (multishelf mode), double-click the DWDM, TXP, or MXP card where you want to change the PM count display interval. The card view appears.

- Step 2** Click the **Performance** tab.
- Step 3** If you want to change the PM interval to 15 minutes for a subtab, click the relevant subtab(s), located along the left side of the Performance tab.
-  **Note** Performance subtabs vary, depending on the card viewed.
- Step 4** If you want to change the PM interval to 15 minutes for a specific port, select the port from the Ports drop-down list (where available).
- Step 5** Go to any of the tabs, subtabs, or ports (found in the Ports drop-down list where available) for that card where you want to set the PM count interval by clicking on the desired subtab and choosing the port from the drop-down list.
- Step 6** Click the **15 min** radio button.
- Step 7** Click **Refresh**. PM parameters appear in 15-minute intervals synchronized with the time of day.
- Step 8** View the Curr column to find PM counts for the current 15-minute interval.
- Each monitored performance parameter has corresponding threshold values for the current time period. If the value of the counter exceeds the threshold value for a particular 15-minute interval, a threshold crossing alert (TCA) is raised. The number represents the counter value for each specific PM parameter.
- Step 9** View the Prev-*n* columns to find PM counts for the previous 15-minute intervals.
-  **Note** If a complete 15-minute interval count is not possible, the value appears with a yellow background. An incomplete or incorrect count can be caused by monitoring for less than 15 minutes after the counter started, changing the node timing settings, changing the time zone settings, replacing a card, resetting a card, or changing port service states. When the problem is corrected, the subsequent 15-minute interval appears with a white background.
- Step 10** Return to your originating procedure (NTP).

DLP-G132 Refresh PM Counts at One-Day Intervals

Purpose	This task changes the window view to display PM parameters in 1-day intervals.
Tools/Equipment	None
Prerequisite Procedures	DLP-G46 Log into CTC, page 2-25
Required/As Needed	As needed
Onsite/Remote	Onsite or remote
Security Level	Retrieve or higher

- Step 1** In node view (single-shelf mode), or shelf view (multishelf mode), double-click the DWDM, TXP, or MXP card where you want to change the PM interval. The card view appears.
- Step 2** Click the **Performance** tab.

Step 3 If you want to refresh the PM counts for a subtab, click the relevant subtab(s), located along the left side of the Performance tab.



Note Performance subtabs vary, depending on the card viewed.

Step 4 If you want to refresh the PM counts for a specific port, select the port from the Ports drop-down list (where available).

Step 5 Click the **1 day** radio button.

Step 6 Click **Refresh**. Performance monitoring appears in 1-day intervals synchronized with the time of day.

Step 7 View the Curr column to find PM counts for the current 1-day interval.

Each monitored performance parameter has corresponding threshold values for the current time period. If the value of the counter exceeds the threshold value for a particular 1-day interval, a TCA is raised. The number represents the counter value for each specific PM parameter.

Step 8 View the Prev-*n* columns to find PM counts for the previous 1-day intervals.



Note If a complete count over a 1-day interval is not possible, the value appears with a yellow background. An incomplete or incorrect count can be caused by monitoring for less than 24 hours after the counter started, changing node timing settings, changing the time zone settings, replacing a card, resetting a card, or changing port service states. When the problem is corrected, the subsequent 1-day interval appears with a white background.

Step 9 Return to your originating procedure (NTP).

DLP-G133 View Near-End PM Counts

Purpose	This task enables you to view near-end PM counts for the selected card and port.
Tools/Equipment	None
Prerequisite Procedures	DLP-G46 Log into CTC, page 2-25
Required/As Needed	As needed
Onsite/Remote	Onsite or remote
Security Level	Retrieve or higher

Step 1 In node view (single-shelf mode), or shelf view (multishelf mode), double-click the DWDM, TXP, or MXP card where you want to view near end PM counts. The card view appears.

Step 2 Click the **Performance** tab.

Step 3 If you want to view the near-end PM counts for a subtab, click the relevant subtab(s), located along the left side of the Performance tab.



Note Performance subtabs vary, depending on the card viewed.

- Step 4** If you want to view near-end PM counts for a specific port, select the port from the Ports drop-down list (where available).
- Step 5** Click the **Near End** radio button, where available. (Viewing near-end PM counts is not available on some tabs.)
- Step 6** Click **Refresh**. All PM parameters occurring for the selected card on the incoming signal appear. For PM parameter definitions, refer to the “Performance Monitoring” chapter in the *Cisco ONS 15454 DWDM Reference Manual*.
- Step 7** View the Curr column to find PM counts for the current time interval.
- Step 8** View the Prev-*n* columns to find PM counts for the previous time intervals.
- Step 9** Return to your originating procedure (NTP).

DLP-G134 View Far-End PM Counts

Purpose	This task enables you to view far-end PM parameters for the selected card and port.
Tools/Equipment	None
Prerequisite Procedures	DLP-G46 Log into CTC, page 2-25
Required/As Needed	As needed
Onsite/Remote	Onsite or remote
Security Level	Retrieve or higher



Note Far-end PM parameters are not available for all ports.

- Step 1** In node view (single-shelf mode), or shelf view (multishelf mode), double-click the DWDM, TXP, or MXP card where you want to view far-end PM counts. The card view appears.
- Step 2** Click the **Performance** tab.
- Step 3** If you want to view far-end PM counts for a subtab, click the relevant subtab(s), located along the left side of the Performance tab.



Note Performance subtabs vary, depending on the card viewed.

- Step 4** If you want to view far-end PM counts for a specific port, select the port from the Ports drop-down list (where available).
- Step 5** Click the **Far End** radio button, where available. (Viewing far-end PM counts is not available on some tabs.)
- Step 6** Click **Refresh**. All PM parameters recorded by the far-end node for the selected card on the outgoing signal appear. For PM parameter definitions, refer to the “Performance Monitoring” chapter in the *Cisco ONS 15454 DWDM Reference Manual*.
- Step 7** View the Curr column to find PM counts for the current time interval.
- Step 8** View the Prev-*n* columns to find PM counts for the previous time intervals.

Step 9 Return to your originating procedure (NTP).

DLP-G135 Reset Current PM Counts

Purpose	This task clears the current PM count, but it does not clear the cumulative PM count. This task allows you to see how quickly PM counts rise.
Tools/Equipment	None
Prerequisite Procedures	DLP-G46 Log into CTC, page 2-25
Required/As Needed	As needed
Onsite/Remote	Onsite or remote
Security Level	Retrieve or higher

Step 1 In node view (single-shelf mode), or shelf view (multishelf mode), double-click the DWDM, TXP, or MXP card where you want to reset the current PM counts. The card view appears.

Step 2 Click the **Performance** tab.

Step 3 If you want to reset the PM counts for a subtab, click the relevant subtab(s), located along the left side of the Performance tab.



Note Performance subtabs vary, depending on the card viewed.

Step 4 If you want to reset the PM counts for a specific port, select the port from the Ports drop-down list (where available).



Note You cannot change the PM count interval on the TXP or MXP card Optics PM > Current Values tab.

Step 5 Click **Baseline**.



Note The Baseline button clears the PM counts displayed in the current time interval but does not clear the PM counts on the card. When the current time interval expires or the window view changes, the total number of PM counts on the card and in the window appears in the appropriate column. The baseline values are discarded if you change views to a different window and then return to the Performance window.

Step 6 View the current statistics columns to observe changes to PM counts for the current time interval.

Step 7 Return to your originating procedure (NTP).

DLP-G136 Clear Selected PM Counts

Purpose	This task uses the Clear button to clear specified PM counts depending on the option selected.
Tools/Equipment	None
Prerequisite Procedures	DLP-G46 Log into CTC, page 2-25
Required/As Needed	As needed
Onsite/Remote	Onsite or remote
Security Level	Superuser



Caution

Pressing the Clear button can mask problems if used incorrectly. This button is commonly used for testing purposes. After pressing this button, the current bin is marked invalid. Also note that the unavailable seconds (UAS) count is not cleared if you were counting UAS; therefore, this count could be unreliable when you press Clear.

-
- Step 1** In node view (single-shelf mode), or shelf view (multishelf mode), double-click the DWDM, TXP, or MXP card where you want to clear the PM counts. The card view appears.
- Step 2** Click the **Performance** tab.
- Step 3** If you want to clear the selected PM counts for a subtab, click the relevant subtab(s), located along the left side of the Performance tab.



Note Performance subtabs vary, depending on the card viewed.

- Step 4** If you want to clear the selected PM counts for a specific port, select the port from the Ports drop-down list (where available).



Note You cannot clear the PM count interval on the TXP or MXP card Optics PM > Current Values tab.

- Step 5** Click **Clear**.
- Step 6** From the Clear Statistics dialog box, click one of the following radio buttons:
- **Displayed statistics:** Clearing displayed statistics erases all PM counts associated with the current combination of statistics on the selected port from the card and the window. This means that the selected time interval, direction, and signal type counts are erased from the card and the window.
 - **All statistics for port *x*:** Clearing all statistics for port *x* erases all PM counts associated with all combinations of the statistics on the selected port from the card and the window. This means that all time intervals, directions, and signal type counts are erased from the card and the window.
 - **All statistics for card:** Clearing all statistics for card erases all PM counts for all ports from the card and the window.
- Step 7** From the Clear Statistics dialog box, click **OK** to clear the selected statistics. Click **Yes** to confirm the change.
- Step 8** Verify that the selected PM counts have been cleared.

Step 9 Return to your originating procedure (NTP).

DLP-G137 Set Auto-Refresh Interval for Displayed PM Counts

Purpose	This task changes the window auto-refresh intervals for updating the PM counts.
Tools/Equipment	None
Prerequisite Procedures	DLP-G46 Log into CTC, page 2-25
Required/As Needed	As needed
Onsite/Remote	Onsite or remote
Security Level	Retrieve or higher

Step 1 In node view (single-shelf mode), or shelf view (multishelf mode), double-click the DWDM, TXP, or MXP card where you want to set the auto-refresh interval for displayed PM counts. The card view appears.

Step 2 Click the **Performance** tab.

Step 3 If you want to set the PM auto-refresh interval for a subtab, click the relevant subtab(s), located along the left side of the Performance tab.



Note Performance subtabs vary, depending on the card viewed.

Step 4 If you want to set the PM auto-refresh interval for a specific port, select the port from the Ports drop-down list (where available).

Step 5 From the Auto-refresh drop-down list, choose one of the following options:

- **None:** This option disables the auto-refresh feature.
- **15 Seconds:** This option sets the window auto-refresh at 15-second time intervals.
- **30 Seconds:** This option sets the window auto-refresh at 30-second time intervals.
- **1 Minute:** This option sets the window auto-refresh at 1-minute time intervals.
- **3 Minutes:** This option sets the window auto-refresh at 3-minute time intervals.
- **5 Minutes:** This option sets the window auto-refresh at 5-minute time intervals.

Step 6 Click **Refresh**. The PM counts for the newly selected auto-refresh time interval appear.

Depending on the selected auto-refresh interval, the displayed PM counts automatically update when each refresh interval completes. If the auto-refresh interval is set to None, the PM counts that appear are not updated unless you click Refresh.

Step 7 Return to your originating procedure (NTP).

DLP-G138 Refresh PM Counts for a Different Port

Purpose	This task changes the window view to display PM counts for another port on a TXP or MXP card.
Tools/Equipment	None
Prerequisite Procedures	DLP-G46 Log into CTC, page 2-25
Required/As Needed	As needed
Onsite/Remote	Onsite or remote
Security Level	Retrieve or higher

-
- Step 1** In node view (single-shelf mode), or shelf view (multishelf mode), double-click the DWDM, TXP, or MXP card where you want to refresh PM counts for a different port. The card view appears.
- Step 2** Click the **Performance** tab.
- Step 3** In the Port drop-down list, choose a port.
- Step 4** Click **Refresh**. The PM counts for the newly selected port appear.
- Step 5** Return to your originating procedure (NTP).
-

NTP-G74 Monitor DWDM Card Performance

Purpose	This procedure enables you to view, transmit, and receive performance information for OSCM, OSC-CSM, 32MUX-O, 32DMX-O, 32DMX-L, 4MD, AD-xC-xx.x, AD-xB-xx.x, 32WSS, 32WSS-L, OPT-BST, OPT-PRE, OPT-BST-L, and OPT-AMP-L cards and ports during selected time intervals to detect possible performance problems.
Tools/Equipment	None
Prerequisite Procedures	Before you monitor performance, be sure you have created the appropriate circuits and provisioned the card according to your specifications. For more information, see Chapter 7, “Create Channels and Circuits” and Chapter 11, “Change DWDM Card Settings.”
Required/As Needed	As needed
Onsite/Remote	Onsite or remote
Security Level	Retrieve or higher

-
- Step 1** Complete the “[DLP-G46 Log into CTC](#)” procedure on page 2-25 at the node that you want to monitor. If you are already logged in, continue with [Step 2](#).
- Step 2** Complete the following tasks as needed:
- [DLP-G139 View Optical Service Channel PM Parameters, page 9-10.](#)
 - [DLP-G140 View Optical Amplifier Power Statistics, page 9-12.](#)
 - [DLP-G141 View Optical Power Statistics for 32MUX-O, 32WSS, 32WSS-L, 32DMX-O, 32DMX, and 32DMX-L Cards, page 9-13.](#)

- [DLP-G276 View 4-Channel Multiplexer/Demultiplexer Optical Power Statistics, page 9-15](#)
- [DLP-G142 View Channel Optical Add/Drop Multiplexer Power Statistics, page 9-16.](#)
- [DLP-G143 View Band Optical Add/Drop Multiplexer Power Statistics, page 9-18.](#)



Note To refresh, reset, or clear PM counts, see the [“NTP-G73 Change the PM Display” procedure on page 9-2.](#)

Stop. You have completed this procedure.

DLP-G139 View Optical Service Channel PM Parameters

Purpose	This task enables you to view optical service channel (OSC) PM counts at selected time intervals on an OSCM or OSC-CSM card and port to detect possible performance problems.
Tools/Equipment	None
Prerequisite Procedures	DLP-G46 Log into CTC, page 2-25
Required/As Needed	As needed
Onsite/Remote	Onsite or remote
Security Level	Retrieve or higher

- Step 1** In node view (single-shelf mode), or shelf view (multishelf mode), double-click the OSCM or OSC-CSM card where you want to view PM counts. The card view appears.
- Step 2** Click the **Performance > OC3 Line** tabs ([Figure 9-1](#)).

Figure 9-1 OC3 Line Tab in the Optical Service Channel Card View Performance Window

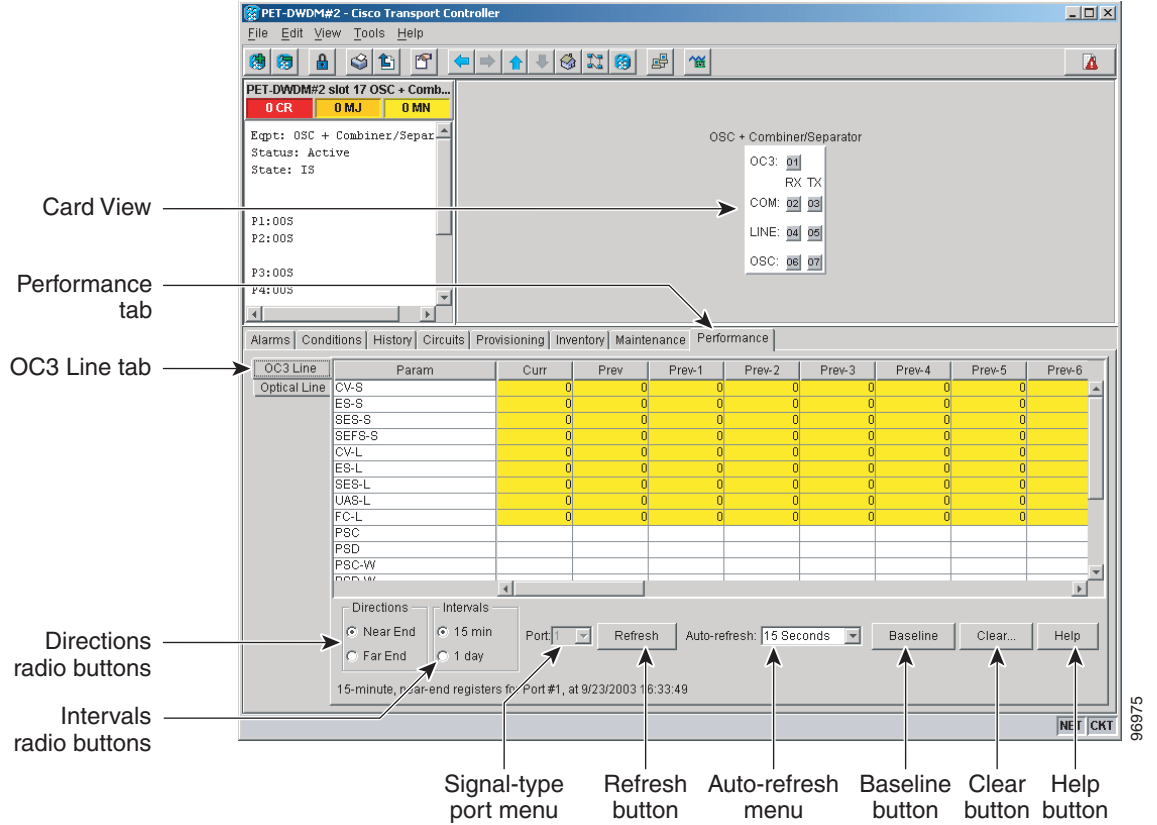

- Step 3** Click **Refresh**. PMs appear for the OC3 (Port 1).
- Step 4** Click the **Optical Line** tab.
- Step 5** In the Port drop-down list, choose the optical line port where you want to view the power statistics:
 - 2—COM RX
 - 3—COM TX
 - 4—LINE RX (available only on the OSC-CSM card)
 - 5—LINE TX (available only on the OSC-CSM card)
 - 6—OSC RX (available only on the OSC-CSM card)
 - 7—OSC TX (available only on the OSC-CSM card)
- Step 6** Click **Refresh**. The minimum, maximum, and average optical power statistics for the selected line port appear.
- Step 7** Return to your originating procedure (NTP).

DLP-G140 View Optical Amplifier Power Statistics

Purpose	This task enables you to view the power statistics on an OPT-PRE, OPT-BST, OPT-BST-L, or OPT-AMP-L amplifier card.
Tools/Equipment	None
Prerequisite Procedures	DLP-G46 Log into CTC, page 2-25
Required/As Needed	As needed
Onsite/Remote	Onsite or remote
Security Level	Retrieve or higher

- Step 1** In node view (single-shelf mode), or shelf view (multishelf mode), double-click the optical amplifier card where you want to view PM counts. The card view appears.
- Step 2** Click the **Performance > Optical Line** tabs (Figure 9-2).

Figure 9-2 Optical Line Tab in the Optical Amplifier Card View Performance Window

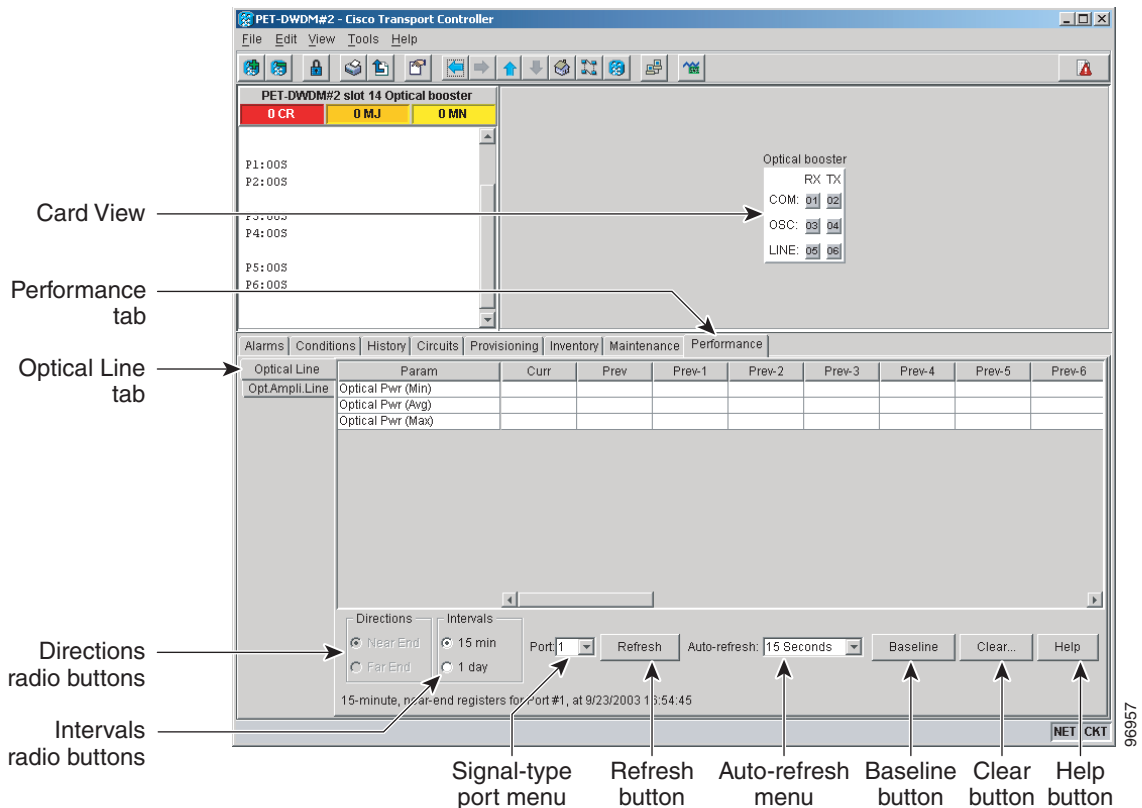

- Step 3** In the Port drop-down list, choose an optical line port where you want to view the optical power statistics:
- For the OPT-PRE card, the following ports are available to view:
 - 1—COM RX
 - 3—DC RX

- 4—DC TX
 - For the OPT-BST and OPT-BST-E cards, the following ports are available to view:
 - 1—COM RX
 - 2—COM TX
 - 4—OSC TX
 - For the OPT-BST-L card, the following ports are available to view:
 - 1—COM RX
 - 2—COM TX
 - 4—OSC TX
 - For the OPT-AMP-L card, the following ports are available to view:
 - 1—COM RX
 - 2—COM TX
 - 4—OSC TX
 - 7—DC RX
 - 8—DC TX
- Step 4** Click **Refresh**. Optical power statistics for the selected port appear.
- Step 5** Click the **Opt. Ampli. Line** tab.
- Step 6** Click **Refresh**. Optical power statistics for the optical amplifier output port (COM TX, Port 02 for the OPT-PRE card, and Line TX, Port 06 for the OPT-BST card) appear.
- Step 7** Return to your originating procedure (NTP).
-

DLP-G141 View Optical Power Statistics for 32MUX-O, 32WSS, 32WSS-L, 32DMX-O, 32DMX, and 32DMX-L Cards

Purpose	This task enables you to view optical power statistics for a 32MUX-O, 32WSS, 32WSS-L, 32DMX-O, 32DMX, or 32DMX-L card.
Tools/Equipment	None
Prerequisite Procedures	DLP-G46 Log into CTC, page 2-25
Required/As Needed	As needed
Onsite/Remote	Onsite or remote
Security Level	Retrieve or higher

- Step 1** In node view (single-shelf mode), or shelf view (multishelf mode), double-click the 32MUX-O, 32WSS, 32WSS-L, 32DMX-O, 32DMX, or 32DMX-L card where you want to view PM counts. The card view appears.
- Step 2** Click the **Performance > Optical Chn** tabs ([Figure 9-3 on page 9-14](#)).

Figure 9-3 Optical Channel Tab in the Multiplexer/Demultiplexer Card View Performance Window

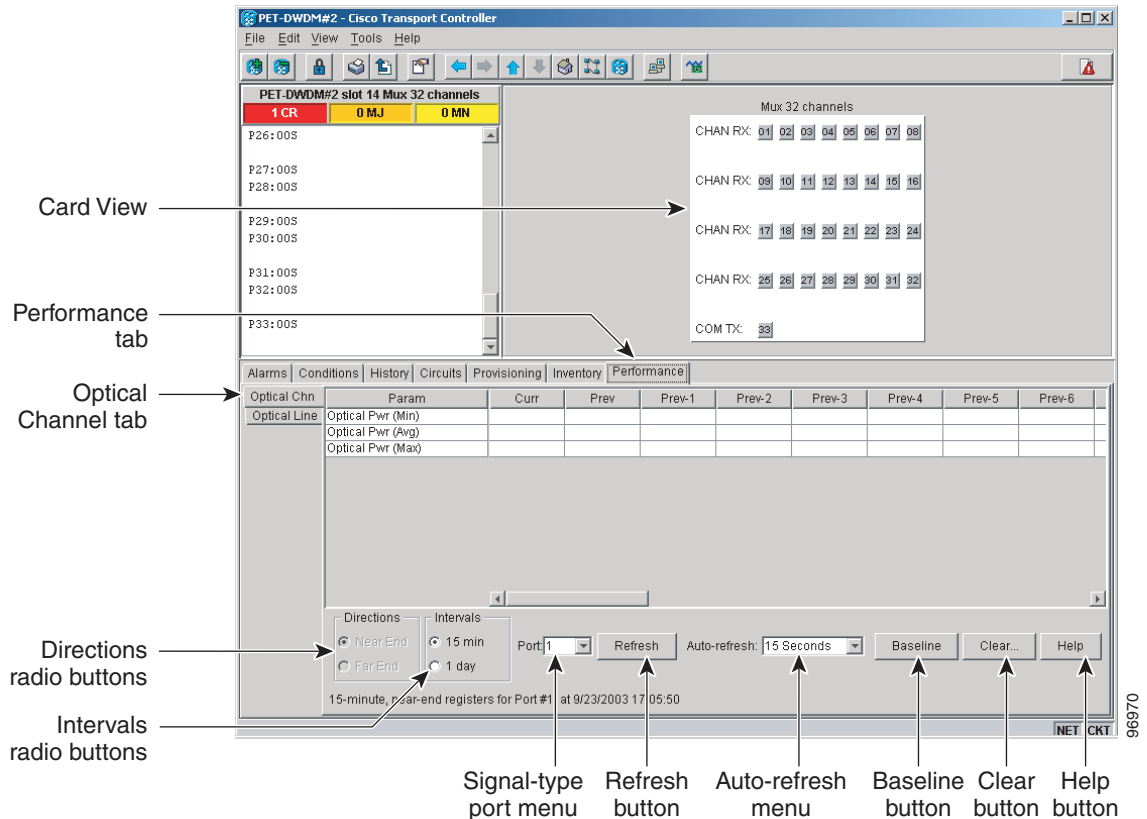

- Step 3** In the Port drop-down list, choose an optical channel to view by selecting the port where you want to view the optical power statistics.
- 32MUX-O—optical channel receive port (CHAN RX), Ports 01 through 32.
 - 32WSS and 32WSS-L—optical channel receive port (ADD RX) Ports 01 through 32, or a pass-through port (PT), Ports 33 through 64.
 - 32DMX-O, 32DMX, and 32DMX-L—optical channel transmit port (CHAN TX), Ports 01 through 32.
- Step 4** Click **Refresh**. Optical channel power statistics (minimum, maximum, average) for the selected port appear.
- Step 5** Click the **Optical Line** tab.
- Step 6** For a 32WSS and 32WSS-L card, select the port for which you wish to monitor power statistics (65, 66, 67, 68, or 69). For a 32DMX, 32DMX-L, or 32DMX-O card, accept the default port (33).
- Step 7** Click **Refresh**. Optical channel power statistics (minimum, maximum, average) for the selected port appear.
- Step 8** Return to your originating procedure (NTP).

DLP-G276 View 4-Channel Multiplexer/Demultiplexer Optical Power Statistics

Purpose	This task enables you to view the minimum, maximum, and average optical power statistics for a 4MD-xx.x card channel and band ports.
Tools/Equipment	None
Prerequisite Procedures	DLP-G46 Log into CTC , page 2-25
Required/As Needed	As needed
Onsite/Remote	Onsite or remote
Security Level	Retrieve or higher

- Step 1** In node view (single-shelf mode), or shelf view (multishelf mode), double-click the 4MD-xxx card where you want to the optical power statistics. The card view appears.
- Step 2** Click the **Performance > Optical Chn** tabs (Figure 9-4).

Figure 9-4 Optical Channel Tab in the 4MD-xx.x Card View Performance Window

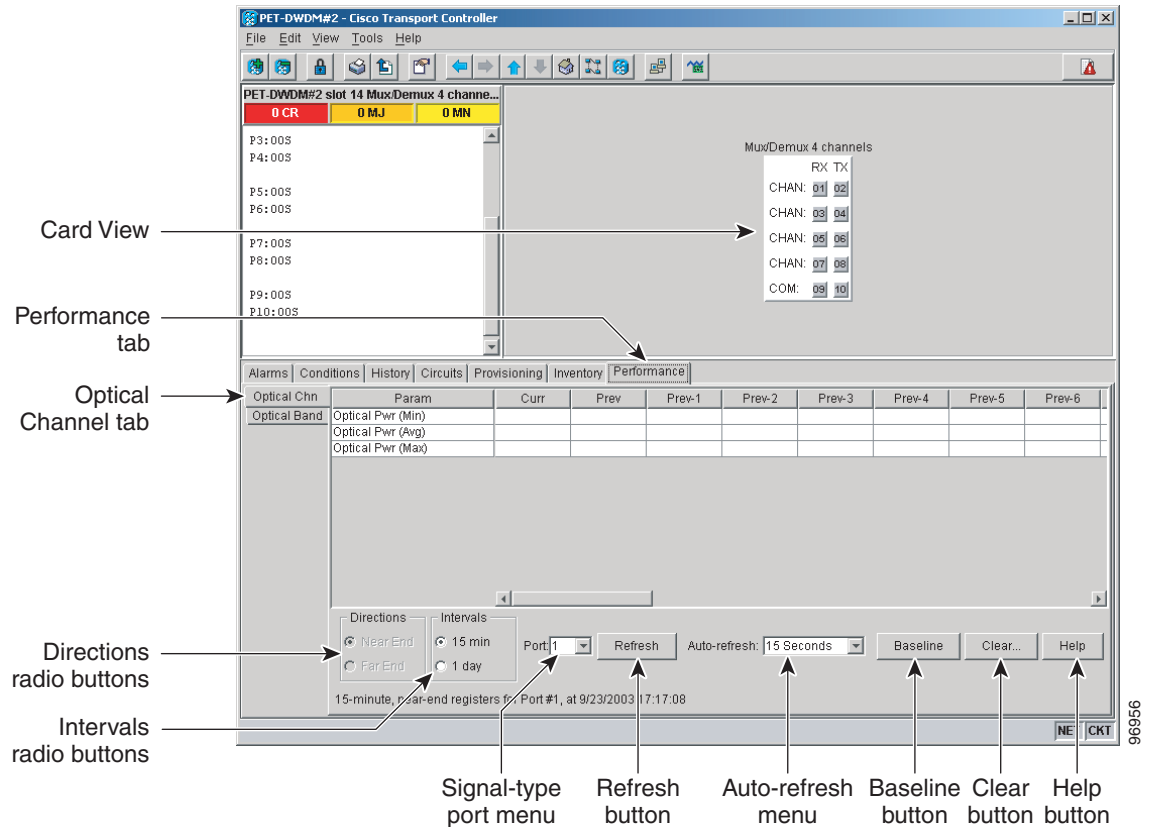

- Step 3** In the Port drop-down list, choose the channel port (1 through 8 for CHAN Ports 01 through 08) where you want to view the power statistics.
- Step 4** Click **Refresh**. The minimum, maximum, and average optical power for the selected channel port appear.
- Step 5** To change the auto-refresh interval, click **Auto Refresh** and choose one of the automatic refresh intervals: None, 15 seconds, 30 seconds, 1 minute, 3 minutes, or 5 minutes.

- Step 6** Click the **Optical Band** tab.
- Step 7** In the Port drop-down list, choose the band port (9 or 10 for COM Ports 09 and 10) where you want to view the power statistics.
- Step 8** Click **Refresh**. The minimum, maximum, and average optical power for the selected band port appear.
- Step 9** To change the auto-refresh interval, click **Auto Refresh** and choose one of the automatic refresh intervals: None, 15 seconds, 30 seconds, 1 minute, 3 minutes, or 5 minutes.
- Step 10** Return to your originating procedure (NTP).
-

DLP-G142 View Channel Optical Add/Drop Multiplexer Power Statistics

Purpose	This task enables you to view channel optical add/drop multiplexer (OADM) minimum, maximum, and average power statistics on an AD-1C-xx.x, AD-2C-xx.x, or AD-4C-xx.x card.
Tools/Equipment	None
Prerequisite Procedures	DLP-G46 Log into CTC, page 2-25
Required/As Needed	As needed
Onsite/Remote	Onsite or remote
Security Level	Retrieve or higher

- Step 1** In node view (single-shelf mode), or shelf view (multishelf mode), double-click the optical AD-xC-xx.x card where you want to view the optical power statistics. The card view appears.
- Step 2** Click the **Performance > Optical Line** tabs ([Figure 9-5](#)).

Figure 9-5 Optical Line Tab in the Channel Filter OADM Card View Performance Window

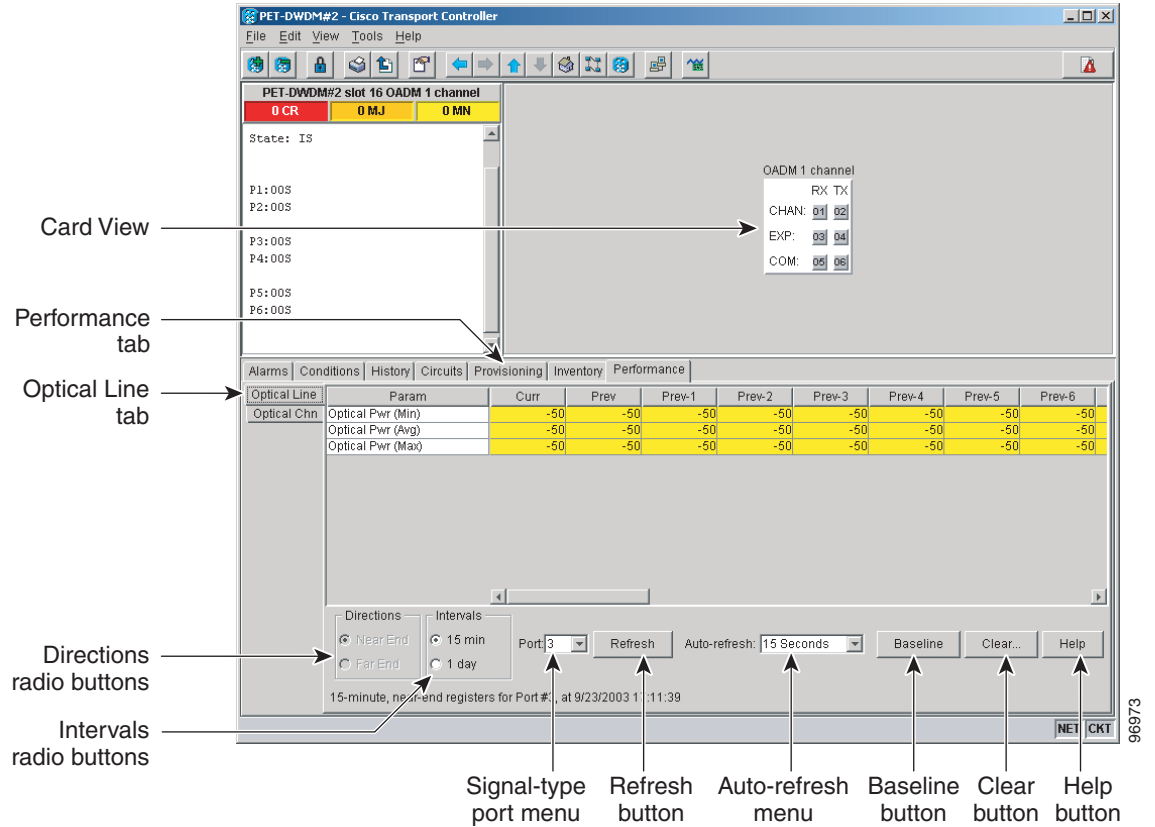

Step 3 In the Port drop-down list, choose an optical line port (Table 9-1) where you want to view the optical power statistics.

Table 9-1 Channel OADM Optical Line Ports

Port Name	Port Number		
	AD-1C-xx.x	AD-2C-xx.x	AD-4C-xx.x
EXP RX	3	5	9
EXP TX	4	6	10
COM RX	5	7	11
COM TX	6	8	12

Step 4 Click **Refresh**. Optical line power statistics for the selected port appear.

Step 5 Click the **Optical Chn** tab.

Step 6 In the Port drop-down list, choose an optical channel port (Table 9-1) where you want to view the optical power statistics.

Table 9-2 Channel OADM Optical Line Ports

Port Name	Port Number		
	AD-1C-xx.x	AD-2C-xx.x	AD-4C-xx.x
CHAN RX	1	1	1
CHAN TX	2	2	2
CHAN RX	—	3	3
CHAN TX	—	4	4
CHAN RX	—	—	5
CHAN TX	—	—	6
CHAN RX	—	—	7
CHAN TX	—	—	8

Step 7 Click **Refresh**. Optical channel PM statistics for the selected port appear.

Step 8 Return to your originating procedure (NTP).

DLP-G143 View Band Optical Add/Drop Multiplexer Power Statistics

Purpose	This task enables you to view band OADM minimum, maximum, and average power statistics on an AD-1B-xx.x or AD-4B-xx.x card.
Tools/Equipment	None
Prerequisite Procedures	DLP-G46 Log into CTC, page 2-25
Required/As Needed	As needed
Onsite/Remote	Onsite or remote
Security Level	Retrieve or higher

Step 1 In node view (single-shelf mode), or shelf view (multishelf mode), double-click the optical AD-xB-xx.x card where you want to view the optical power statistics. The card view appears.

Step 2 Click the **Performance > Optical Line** tabs.

Step 3 In the Port drop-down list, choose an optical line port ([Table 9-3](#)) where you want to view the optical power statistics.

Table 9-3 Band OADM Optical Line Ports

Port Name	Port Number	
	AD-1B-xx.x	AD-4B-xx.x
EXP RX	3	9
EXP TX	4	10
COM RX	5	11
COM TX	6	12

- Step 4** Click **Refresh**. Optical line power statistics for the selected port appear.
- Step 5** Click the **Optical Band** tab.
- Step 6** In the Port drop-down list, choose an optical band port ([Table 9-4](#)) where you want to view the optical power statistics.

Table 9-4 Band OADM Optical Line Ports

Port Name	Port Number	
	AD-1B-xx.x	AD-4B-xx.x
BAND RX	1	1
BAND TX	2	2
BAND RX	—	3
BAND TX	—	4
BAND RX	—	5
BAND TX	—	6
BAND RX	—	7
BAND TX	—	8

- Step 7** Click **Refresh**. Optical channel PM statistics for the selected port appear.
- Step 8** Return to your originating procedure (NTP).

NTP-G75 Monitor Transponder and Muxponder Performance

Purpose	This procedure enables you to view node near-end or far-end performance during selected time intervals on a transponder card (TXP_MR_10G, TXP_MR_2.5G, TXPP_MR_2.5G, TXP_MR_10E, TXP_MR_10E_C, TXP_MR_10E_L) or muxponder card (MXP_MR_10DME_C, MXP_MR_10DME_L, MXP_2.5G_10E, MXP_MR_2.5G, MXPP_MR_2.5G, MXP_2.5G_10G, MXP_2.5G_10E_C, MXP_2.5G_10E_L) to detect possible performance problems.
Tools/Equipment	None
Prerequisite Procedures	Before you monitor performance, be sure you have created the appropriate circuits and provisioned the card according to your specifications. For more information, see Chapter 7, “Create Channels and Circuits,” Chapter 5, “Provision Transponder and Muxponder Cards,” or Chapter 11, “Change DWDM Card Settings.”
Required/As Needed	As needed
Onsite/Remote	Onsite or remote
Security Level	Retrieve or higher

-
- Step 1** Complete the “[DLP-G46 Log into CTC](#)” task on page 2-25 at the node that you want to monitor. If you are already logged in, continue with Step 2.
- Step 2** Complete the “[DLP-G144 Enable or Disable OTN ITU-T G.709 Performance Monitoring](#)” task on page 9-20 as needed for any TXP or MXP card (except the TXP_MR_10E and MXP_2.5G_10E cards) to enable or disable optical transport network (OTN) ITU-T G.709 monitoring.
- Step 3** Complete the “[DLP-G145 Enable or Disable OTN FEC Performance Monitoring](#)” task on page 9-21 as needed for TXP_MR_10E and MXP_2.5G_10E cards to enable or disable OTN forward error correction (FEC) monitoring.
- Step 4** Complete the following tasks as needed to view PM parameters:
- [DLP-G146 View Optics PM Parameters](#), page 9-22
 - [DLP-G147 View Payload PM Parameters](#), page 9-23
 - [DLP-G148 View OTN PM Parameters](#), page 9-25
 - [DLP-G149 View Payload Statistics PM Parameters](#), page 9-27
 - [DLP-G150 View Payload Utilization PM Parameters](#), page 9-29
 - [DLP-G151 View Payload History PM Parameters](#), page 9-30
 - [DLP-G152 View Payload SONET/SDH PM Parameters](#), page 9-32



Note To refresh, reset, or clear PM counts, see the “[NTP-G73 Change the PM Display](#)” procedure on page 9-2.

Stop. You have completed this procedure.

DLP-G144 Enable or Disable OTN ITU-T G.709 Performance Monitoring

Purpose	This task enables or disables OTN ITU-T G.709 monitoring of near-end or far-end performance on a card and port during selected time intervals to detect possible problems. This task can be performed for any TXP or MXP card except the TXP_MR_10E and MXP_2.5G_10E cards. See the “ DLP-G145 Enable or Disable OTN FEC Performance Monitoring ” task on page 9-21 for TXP_MR_10E and MXP_2.5G_10E card information.
Tools/Equipment	None
Prerequisite Procedures	DLP-G46 Log into CTC , page 2-25
Required/As Needed	As needed
Onsite/Remote	Onsite or remote
Security Level	Provisioning or higher

-
- Step 1** In node view (single-shelf mode), or shelf view (multishelf mode), double-click the card you want to monitor. The card view appears.

- Step 2** Determine if the port where you want to enable or disable OTN ITU-T G.709 is in service (IS). (Click the **Provisioning** > **Line** tabs, and observe the Service State column for that port.) If it is IS, perform the following tasks for that port. If not, go to [Step 3](#).
- [DLP-G108 Change the Service State for a Port, page 7-25](#) to set the port to Out of Service, Disabled (OOS,DSBLD).
 - [DLP-G185 Delete a DCC/GCC Termination, page 10-43](#), if a generic communications channel (GCC) is provisioned on that port.
- Step 3** Click the **Provisioning** > **OTN** > **OTN Lines** tabs.
- Step 4** From the G.709 OTN drop-down list, select **Enable** or **Disable** to enable or disable ITU-T G.709 for that port. (Disable is the default).
- Step 5** Click **Apply**.
- Step 6** Click the **Performance** tab to view PM parameters. For PM parameter definitions, refer to the “Performance Monitoring” chapter in the *Cisco ONS 15454 DWDM Reference Manual*.
-  **Note** If you set the port’s service state to OOS,DSBLD in [Step 2](#), set the port’s service state back to IS, and provision the GCC for that port according to the “[DLP-G76 Provision DCC/GCC Terminations](#)” procedure on page 7-22.
- Step 7** Return to your originating procedure (NTP).

DLP-G145 Enable or Disable OTN FEC Performance Monitoring

Purpose	This task enables or disables OTN FEC monitoring of node near-end or far-end performance on a selected TXP_MR_10E or MXP_2.5G_10E card and port during selected time intervals.
Tools/Equipment	None
Prerequisite Procedures	DLP-G46 Log into CTC, page 2-25
Required/As Needed	As needed
Onsite/Remote	Onsite or remote
Security Level	Provisioning or higher

- Step 1** In node view (single-shelf mode), or shelf view (multishelf mode), double-click the card you want to monitor. The card view appears.
- Step 2** Determine if the port where you want to enable or disable FEC is in service (IS). (Click the **Provisioning** > **Line** tabs, and observe the Service State column for that port.) If it is IS, perform the following tasks for that port. If not, go to [Step 3](#).
- [DLP-G108 Change the Service State for a Port, page 7-25](#) to set the port to OOS,DSBLD.
 - [DLP-G185 Delete a DCC/GCC Termination, page 10-43](#), if GCC is provisioned on that port.
- Step 3** Click the **Provisioning** > **OTN** > **OTN Lines** tabs.
- Step 4** Make an FEC selection based on the following rules:
- Choose **Disable** to disable the OTN FEC monitoring.

- Choose **Enable** to enable standard FEC monitoring for that port (default).

Step 5 Click **Apply**.

Step 6 Click the following:

- **Performance > OTN PM > G.709 PM** tabs to view G.709 PM parameters.
- **Performance > OTN PM > FEC PM** to view FEC PM parameters.

For PM parameter definitions, refer to the “Performance Monitoring” chapter in the *Cisco ONS 15454 DWDM Reference Manual*.



Note If you set the port’s service state to OOS,DSBLD in [Step 2](#), set the port’s service state back to IS, and provision the GCC for that port according to the “[DLP-G76 Provision DCC/GCC Terminations](#)” procedure on page 7-22.

Step 7 Return to your originating procedure (NTP).

DLP-G146 View Optics PM Parameters

Purpose	This task enables you to view the optics PM counts on transponder cards (TXP_MR_10G, TXP_MR_2.5G, TXPP_MR_2.5G, TXP_MR_10E, TXP_MR_10E_C, TXP_MR_10E_L), or muxponder cards (MXP_2.5G_10E, MXP_2.5G_10E_C, MXP_2.5G_10E_L, MXP_MR_2.5G, MXPP_MR_2.5G, MXP_2.5G_10G, MXP_MR_10DME_C, MXP_MR_10DME_L) to detect possible performance problems.
Tools/Equipment	None
Prerequisite Procedures	DLP-G46 Log into CTC, page 2-25
Required/As Needed	As needed
Onsite/Remote	Onsite or remote
Security Level	Retrieve or higher

Step 1 In node view (single-shelf mode), or shelf view (multishelf mode), double-click the transponder or muxponder card where you want to view PM counts. The card view appears.

Step 2 Click the **Performance > Optics PM** tabs ([Figure 9-6](#)).

Figure 9-6 Viewing Optics Performance Monitoring Information

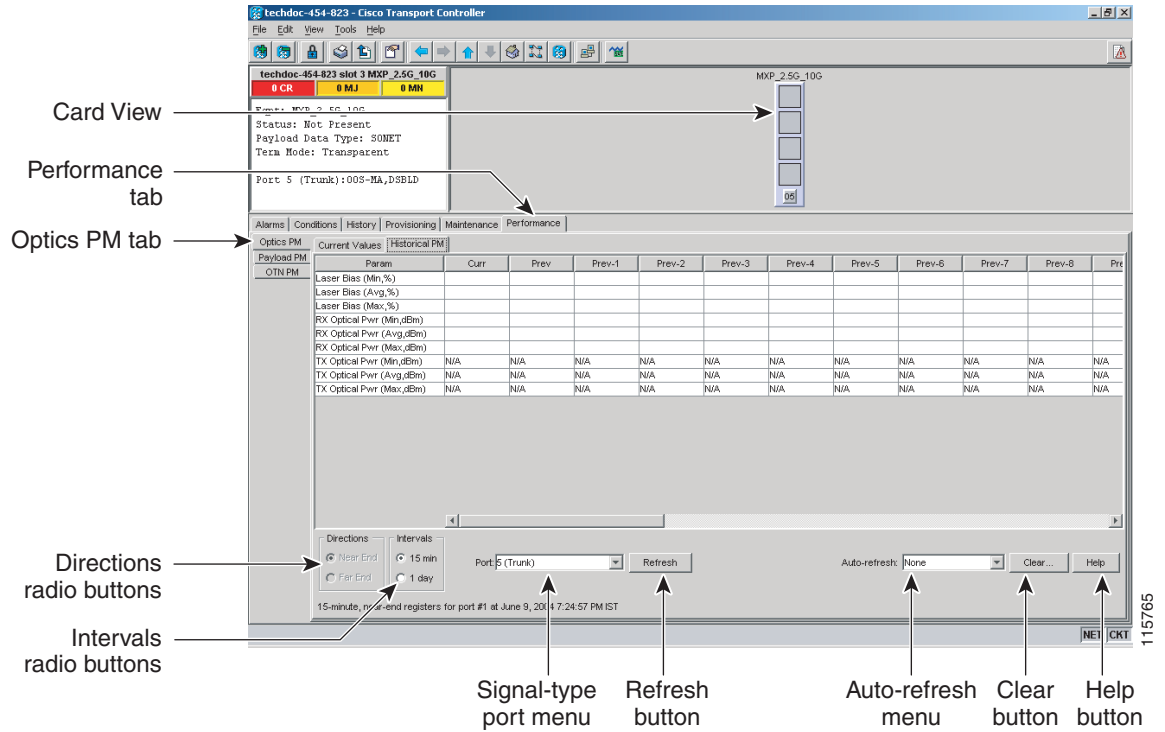

Step 3 View the PM parameter names that appear in the Param column of the Current Values and History PM tabs. The PM parameter values appear in the Curr (current) and Prev-*n* (previous) columns. For PM parameter definitions, refer to the “Performance Monitoring” chapter in the *Cisco ONS 15454 DWDM Reference Manual*.

Step 4 Return to your originating procedure (NTP).

DLP-G147 View Payload PM Parameters

Purpose This task enables you to view the payload PM counts on a transponder cards (TXP_MR_10G, TXP_MR_2.5G, TXPP_MR_2.5G, TXP_MR_10E, TXP_MR_10E_C, TXP_MR_10E_L), or muxponder cards (MXP_2.5G_10E, MXP_2.5G_10E_C, MXP_2.5G_10E_L, MXP_MR_2.5G, MXPP_MR_2.5G, MXP_2.5G_10G, MXP_MR_10DME_C, MXP_MR_10DME_L) to detect possible performance problems.

Tools/Equipment None

Prerequisite Procedures [DLP-G46 Log into CTC, page 2-25](#)

Required/As Needed As needed

Onsite/Remote Onsite or remote

Security Level Retrieve or higher

- Step 1** In node view (single-shelf mode), or shelf view (multishelf mode), double-click the transponder or muxponder card where you want to view PM counts. The card view appears.
- Step 2** Click the **Performance > Payload PM** tabs (Figure 9-7).

Figure 9-7 Viewing Payload Performance Monitoring Information

The screenshot shows the Cisco Transport Controller interface for a transponder card. The card view displays details such as 'Expt: TXPP_MR_2.5G', 'Status: Not Present', and 'Payload Data Type: 0C48'. The Performance tab is active, showing the Payload PM subtab. A table displays PM parameters and their current and previous values. The interface also includes controls for directions, intervals, and a port selection menu.

Optics PM	Param	Curr	Prev	Prev-1	Prev-2	Prev-3	Prev-4	Prev-5	Prev-6
Payload PM	CV-S								
OTN PM	ES-S								
	SEFS-S								
	SEFS-S								
	CV-L								
	ES-L								
	SES-L								
	UAS-L								
	FC-L								

- Step 3** Go to any of the tabs, subtabs, or ports (found in the Ports drop-down list where available) for the card where you want to view the payload PM parameters by clicking on the desired subtab, and choosing the port from the Port drop-down list.
- Step 4** View the PM parameter names that appear in the Param column of the Current Values and History PM tabs. The PM parameter values appear in the Curr (current), and Prev-*n* (previous) columns. For PM parameter definitions, refer to the “Performance Monitoring” chapter in the *Cisco ONS 15454 DWDM Reference Manual*.



Note The payload PMs for data parameters can be viewed only after creating a pluggable port module (PPM). See the “NTP-G128 Manage Pluggable Port Modules” procedure on page 5-2 for more information about PPMs.

**Note**

The PM parameters that appear depend on the data payload and framing type provisioned on the port. Unframed data payloads such as Enterprise System Connection (ESCON), DV6000, DSI/D1 video, and high-definition television (HDTV) do not provide payload PM information. The PM parameters that appear also depend on the PPM payload configured. The TXP_MR_10E card supports three payloads, the MXP_2.5G_10G and MXP_2.5G_10E cards support the OC48/STM16 payload, and the MXP_MR_2.5G and MXPP_MR_2.5G cards support the 1G FC, 2G FC, 1G FICON, 2G FICON, and 1GE payloads.

Step 5 Return to your originating procedure (NTP).

DLP-G148 View OTN PM Parameters

Purpose	This task enables you to view the OTN PM counts on a transponder cards (TXP_MR_10G, TXP_MR_2.5G, TXPP_MR_2.5G, TXP_MR_10E, TXP_MR_10E_C, TXP_MR_10E_L, 10DME_C, 10DME_L), or muxponder cards (MXP_2.5G_10E, MXP_2.5G_10E_C, MXP_2.5G_10E_L, MXP_2.5G_10G, MXP_MR_10DME_C, MXP_MR_10DME_L) to detect possible performance problems.
Tools/Equipment	None
Prerequisite Procedures	DLP-G46 Log into CTC, page 2-25
Required/As Needed	As needed
Onsite/Remote	Onsite or remote
Security Level	Retrieve or higher

Step 1 In node view (single-shelf mode), or shelf view (multishelf mode), double-click the TXP or MXP card where you want to view PM counts. The card view appears.

Step 2 Click the **Performance > OTN PM > G.709 PM** tabs ([Figure 9-8](#)).

Figure 9-8 Viewing OTN ITU-T G.709 Performance Monitoring Information

Card View

Performance tab

G.709 PM tab

OTN PM tab

Directions radio buttons

Intervals radio buttons

Signal-type port menu

Refresh button

Auto-refresh menu

Baseline button

Clear button

Help button

Param	Curr	Prev	Prev-1	Prev-2	Prev-3	Prev-4	Prev-5	Prev-6
BBE-SM								
ES-SM								
SES-SM								
UAS-SM								
FC-SM								
ESR-SM								
SESR-SM								
BBER-SM								
BBE-PM								
ES-PM								
SES-PM								

Step 3 View the PM parameter names that appear in the Param column. The PM parameter values appear in the Curr (current) and Prev-*n* (previous) columns. For PM parameter definitions, refer to the “Performance Monitoring” chapter in the *Cisco ONS 15454 DWDM Reference Manual*.

Step 4 Click the **FEC PM** tab (Figure 9-9).

Figure 9-9 Viewing OTN FEC Performance Monitoring Information

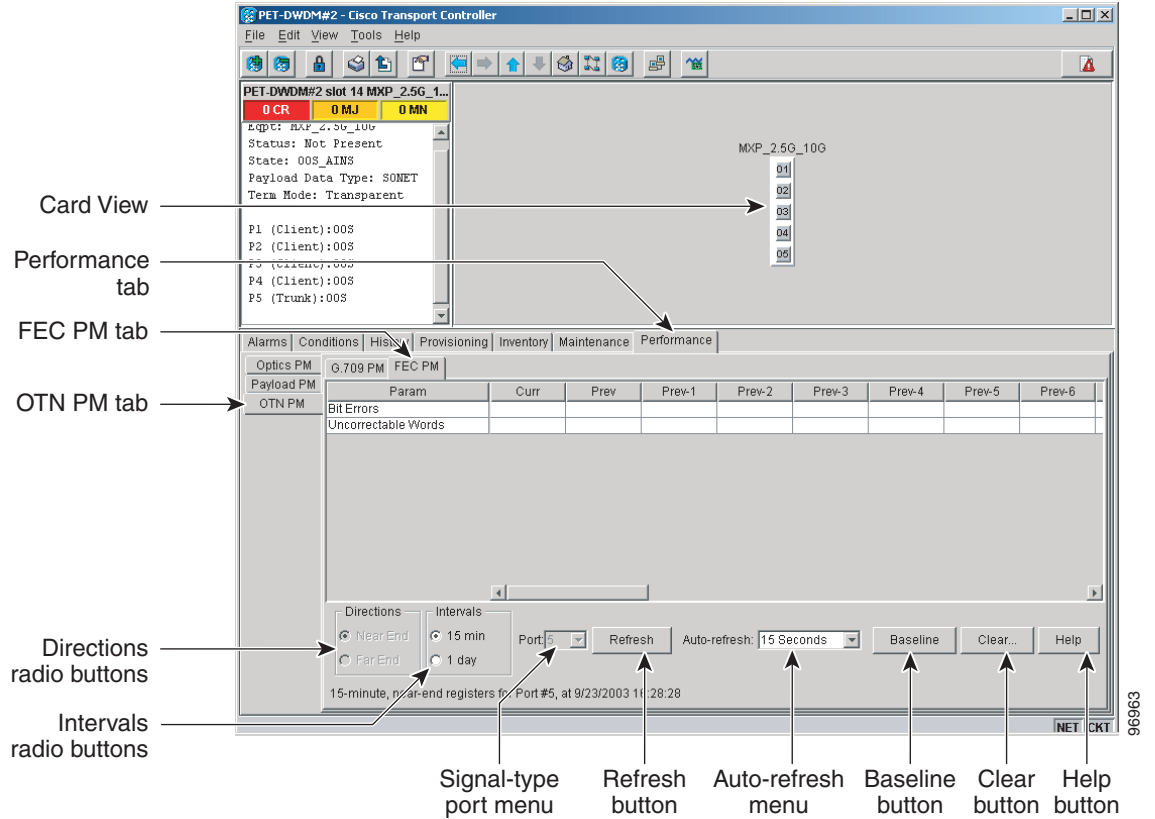

- Step 5** View the PM parameter names that appear in the Param column. The PM parameter values appear in the Curr (current) and Prev-n (previous) columns. For PM parameter definitions, refer to the “Performance Monitoring” chapter in the *Cisco ONS 15454 DWDM Reference Manual*.
- Step 6** Return to your originating procedure (NTP).

DLP-G149 View Payload Statistics PM Parameters

Purpose	This task enables you to view current statistical PM counts on an MXP_MR_2.5G or MXPP_MR_2.5G card and port to detect possible performance problems.
Tools/Equipment	None
Prerequisite Procedures	DLP-G46 Log into CTC, page 2-25
Required/As Needed	As needed
Onsite/Remote	Onsite or remote
Security Level	Retrieve or higher

- Step 1** In node view (single-shelf mode), or shelf view (multishelf mode), double-click the MXP_MR_2.5G or MXPP_MR_2.5G card where you want to view PM counts. The card view appears.

Step 2 Click the **Performance > Payload PM > Statistics** tabs (Figure 9-10).

Figure 9-10 *Statistics Tab on the Card View Performance Window*

Card View

Performance tab

Statistics tab

Payload PM tab

Refresh button

Auto-refresh menu

Baseline button

Clear button

Help button

Param	Port 1-1 (FC2G)	Port 1 (GFP)	
Time Last Clear			N/A
ifnOctets			N/A
ifnDiscards			N/A
ifnErrors			N/A
ifOutOctets			N/A
ifOutDiscards			N/A
txTotalPkts			N/A
rxTotalPkts			N/A
grpStatsRvSBEErrors			N/A
grpStatsRvMEMErrors			N/A
grpStatsRvTypeErrors			N/A
grpStatsRvCRCErrors			N/A
grpStatsLDFRaising			N/A
grpStatsCSFRaising			N/A
medianStatsRvFramesTruncated			N/A
medianStatsRvFramesTooLong			N/A
medianStatsRvFramesBadCRC			N/A
medianStatsRvFramesBadCRC			N/A
fcIngressRvDataQueueExitBuffers			N/A
fcEgressTxDataQueueExitBuffers			N/A
fcStatsLinkRecoveries			N/A

Step 3 Click **Refresh**. PM statistics appear for each port on the card.

Step 4 View the PM parameter names that appear in the Param column. The current PM parameter values appear in the Port # columns. For PM parameter definitions, refer to the “Performance Monitoring” chapter in the *Cisco ONS 15454 DWDM Reference Manual*.



Note To refresh, reset, or clear PM counts, see the “NTP-G73 Change the PM Display” procedure on page 9-2.

Step 5 Return to your originating procedure (NTP).

DLP-G150 View Payload Utilization PM Parameters

Purpose	This task enables you to view line utilization PM counts on an MXP_MR_2.5G or MXPP_MR_2.5G card and port to detect possible performance problems.
Tools/Equipment	None
Prerequisite Procedures	DLP-G46 Log into CTC , page 2-25
Required/As Needed	As needed
Onsite/Remote	Onsite or remote
Security Level	Retrieve or higher

- Step 1** In node view (single-shelf mode), or shelf view (multishelf mode), double-click the MXP_MR_2.5G or MXPP_MR_2.5G card where you want to view PM counts. The card view appears.
- Step 2** Click the **Performance > Payload PM > Utilization** tabs ([Figure 9-11](#)).

Figure 9-11 Utilization Tab on the Card View Performance Window

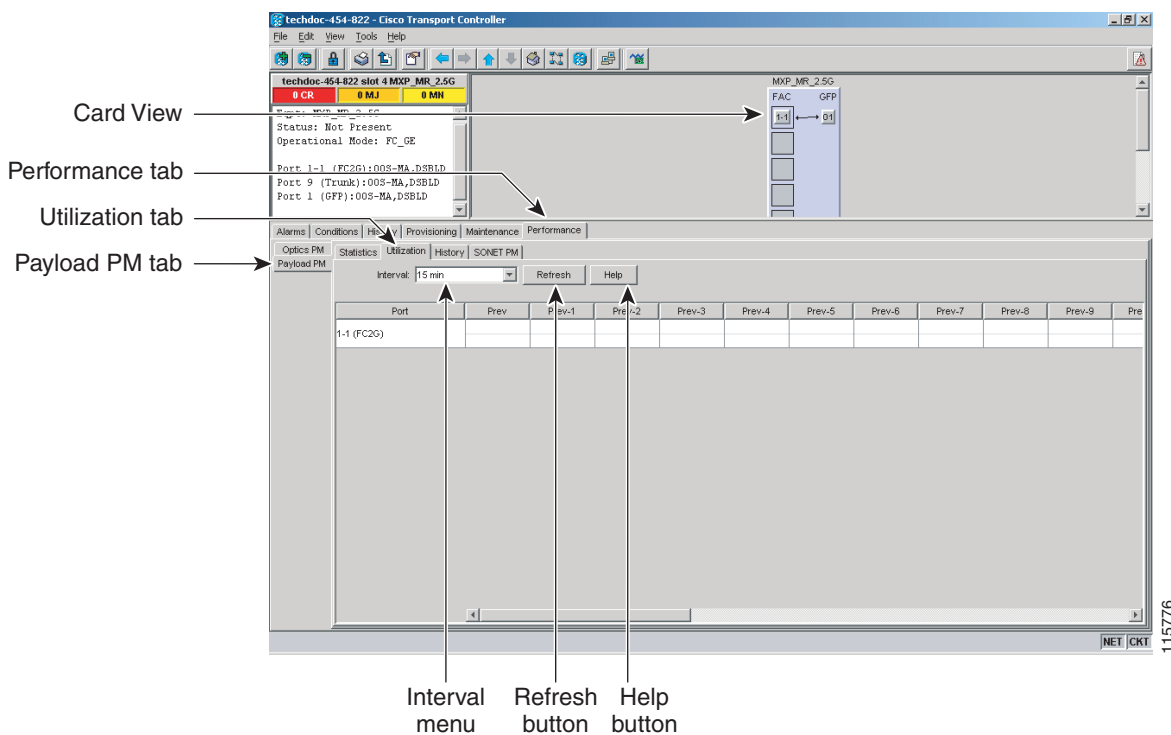

- Step 3** Click **Refresh**. PM utilization values appear for each port on the card.
- Step 4** View the appropriate row for the port you want to monitor.
- Step 5** The transmit (Tx) and receive (Rx) bandwidth utilization values for the previous time intervals appear in the Prev-*n* columns. For PM parameter definitions, refer to the “Performance Monitoring” chapter in the *Cisco ONS 15454 DWDM Reference Manual*.



Note To refresh, reset, or clear PM counts, see the “[NTP-G73 Change the PM Display](#)” procedure on [page 9-2](#).

Step 6 Return to your originating procedure (NTP).

DLP-G151 View Payload History PM Parameters

Purpose	This task enables you to view historical PM counts at selected time intervals on an MXP_MR_2.5G or MXPP_MR_2.5G card and port to detect possible performance problems.
Tools/Equipment	None
Prerequisite Procedures	DLP-G46 Log into CTC, page 2-25
Required/As Needed	As needed
Onsite/Remote	Onsite or remote
Security Level	Retrieve or higher

Step 1 In node view (single-shelf mode), or shelf view (multishelf mode), double-click the MXP_MR_2.5G or MXPP_MR_2.5G card where you want to view PM counts. The card view appears.

Step 2 Click the **Performance > Payload PM > History** tabs ([Figure 9-12](#)).

Figure 9-12 History Tab on the Card View Performance Window

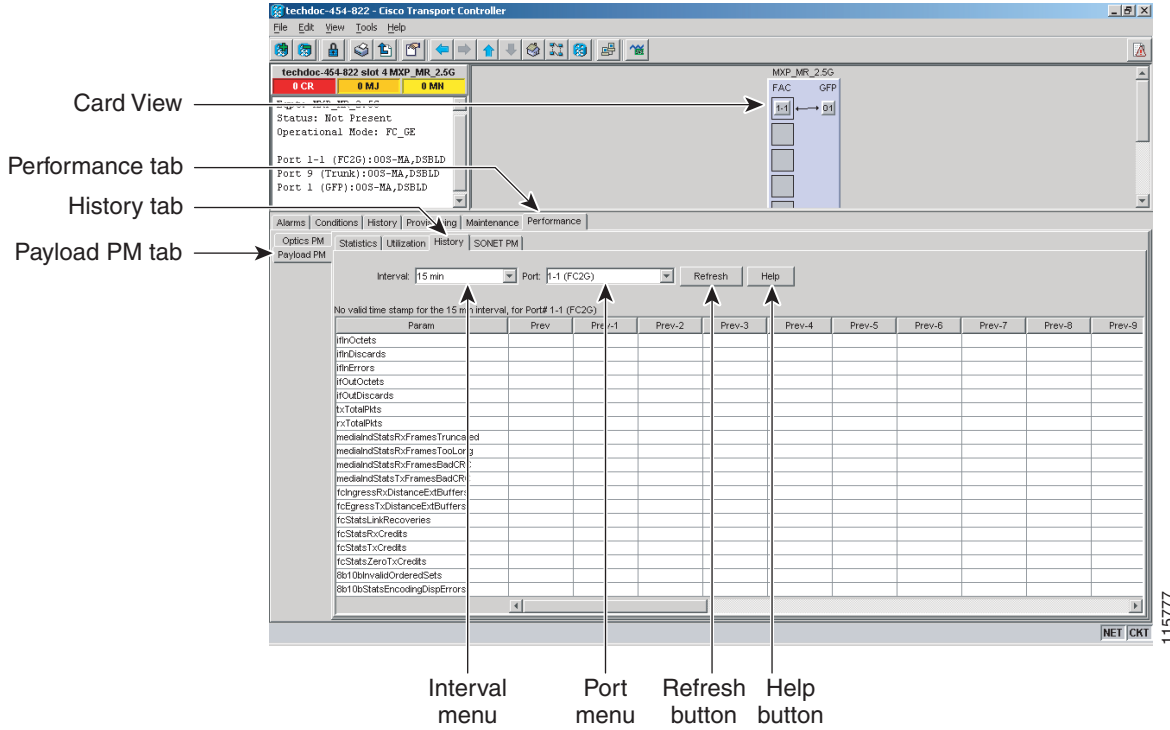

- Step 3** Select the desired port from the Port drop-down list.
- Step 4** Click **Refresh**. PM statistics appear for the selected port.
- Step 5** View the PM parameter names that appear in the Param column. The PM parameter values appear in the Prev-n columns. For PM parameter definitions, refer to the “Performance Monitoring” chapter in the *Cisco ONS 15454 DWDM Reference Manual*.



Note To refresh, reset, or clear PM counts, see the [“NTP-G73 Change the PM Display” procedure on page 9-2](#).

- Step 6** Return to your originating procedure (NTP).

DLP-G152 View Payload SONET/SDH PM Parameters

Purpose	This task enables you to view SONET/SDH PM counts at selected time intervals on an MXP_MR_2.5G or MXPP_MR_2.5G card and port to detect possible performance problems.
Tools/Equipment	None
Prerequisite Procedures	DLP-G46 Log into CTC, page 2-25
Required/As Needed	As needed
Onsite/Remote	Onsite or remote
Security Level	Retrieve or higher

- Step 1** In node view (single-shelf mode), or shelf view (multishelf mode), double-click the MXP_MR_2.5G or MXPP_MR_2.5G card where you want to view PM counts. The card view appears.
- Step 2** Click the **Performance > Payload PM > SONET** or **SDH** tabs ([Figure 9-13](#)).

Figure 9-13 SONET PM Tab on the Card View Performance Window

The screenshot shows the CTC interface for a Cisco Transport Controller. The main window displays the performance monitoring window for an MXP_MR_2.5G card. The interface is divided into several sections:

- Card View:** Shows the card status (Not Present) and operational mode (FC_GE). It lists three ports: Port 1-1 (FC2G):00S-MA,DSB1D; Port 9 (Trunk):00S-MA,DSB1D; and Port 1 (GFP):00S-MA,DSB1D.
- Performance Tab:** Contains sub-tabs for Alarms, Conditions, History, Provisioning, Maintenance, and Performance. The Performance sub-tab is active.
- SONET PM Tab:** Contains sub-tabs for Optics PM, Statistics, Utilization, and History. The SONET PM sub-tab is active.
- Payload PM Tab:** Contains a table with columns for Param, Curr, Prev, Prev-1, Prev-2, Prev-3, Prev-4, Prev-5, Prev-6, Prev-7, Prev-8, and Pre. The Param column lists various SONET/SDH parameters like CV-S, ES-S, SES-S, SEFS-S, CV-L, ES-L, SES-L, UAS-L, and FC-L.
- Directions and Intervals:** Radio buttons for Near End, Far End, 15 min, and 1 day.
- Buttons:** Refresh, Auto-refresh, Baseline, Clear, and Help buttons.

- Step 3** Click **Refresh**. PM statistics appear for the selected port.
- Step 4** View the PM parameter names that appear in the Param column. The PM parameter values appear in the Prev-*n* columns. For PM parameter definitions, refer to the “Performance Monitoring” chapter in the *Cisco ONS 15454 DWDM Reference Manual*.



Note The MXP_MR_2.5G and MXPP_MR_2.5G cards support only the OC48/STM16 payload. Each payload has a set of PM parameters.



Note To refresh, reset, or clear PM counts, see the [“NTP-G73 Change the PM Display” procedure on page 9-2](#).

Step 5 Return to your originating procedure (NTP).



Manage the Node

This chapter explains how to modify node provisioning for the Cisco ONS 15454 and perform common management tasks such as monitoring the dense wavelength division multiplexing (DWDM) automatic power control (APC) and span loss values. To provision a new node, see [Chapter 3, “Turn Up a Node.”](#) To change default network element (NE) settings and to view a list of those settings, refer to the “Network Element Defaults” appendix in the *Cisco ONS 15454 DWDM Reference Manual*.



Note

Unless otherwise specified, “ONS 15454” refers to both ANSI and ETSI shelf assemblies.

Before You Begin

Before performing the following procedures, investigate all alarms and clear any trouble conditions. Refer to the *Cisco ONS 15454 DWDM Troubleshooting Guide* as necessary.

This section lists the chapter procedures (NTPs). Turn to a procedure for applicable tasks (DLPs).

1. [NTP-G76 Verify Optical Span Loss Using CTC, page 10-2](#)—Complete this procedure as needed to view or modify the DWDM span loss values.
2. [NTP-G77 Manage Automatic Power Control, page 10-3](#)—Complete this procedure as needed to manage the DWDM APC.
3. [NTP-G78 View ROADM Node Power Equalization, page 10-5](#)—Complete this procedure as needed to view and update a reconfigurable optical add/drop multiplexing (ROADM) node’s power equalization.
4. [NTP-G80 Change Node Management Information, page 10-6](#)—Complete this procedure as needed to change node name, contact information, latitude, longitude, date, time, and login legal disclaimer.
5. [NTP-G134 Modify OSI Provisioning, page 10-9](#)—Complete this procedure as needed to modify Open System Interconnection (OSI) parameters including the OSI routing mode, Target Identifier Address Resolution Protocol (TARP), routers, subnets, and IP-over-connectionless network service (CLNS) tunnels.
6. [NTP-G81 Change CTC Network Access, page 10-18](#)—Complete this procedure as needed to change the IP address, default router, subnet mask, network configuration settings, and static routes.
7. [NTP-G82 Customize the CTC Network View, page 10-26](#)—Complete this procedure as needed to create domains and customize the appearance of the network map, including specifying a different default map, creating domains, consolidating links in the network view, selecting your own map or image, and changing the background color.

8. [NTP-G83 Modify or Delete Card Protection Settings, page 10-34](#)—Complete this procedure as needed.
9. [NTP-G84 Initiate and Clear Y-Cable and Splitter External Switching Commands, page 10-37](#)—Complete this procedure as needed.
10. [NTP-G85 Modify or Delete OSC Terminations, DCC/GCC Terminations, and Provisionable Patchcords, page 10-42](#)—Complete this procedure as needed to modify or delete generic communications channel (GCC) terminations, optical service channel (OSC) terminations, and provisionable patchcords.
11. [NTP-G86 Convert a Pass-Through Connection to Add/Drop Connections, page 10-45](#)—Complete this procedure as needed to convert a pass-through connection to an add/drop connection.
12. [NTP-G87 Change Node Timing Parameters, page 10-47](#)—Complete this procedure as needed.
13. [NTP-G88 Modify Users and Change Security, page 10-48](#)—Complete this procedure as needed to make changes to user settings, including security level and security policies, and to delete users.
14. [NTP-G131 Convert DWDM Nodes to Hybrid Nodes, page 10-61](#)—Complete this procedure as needed to convert a DWDM node to a hybrid node.
15. [NTP-G89 Change SNMP Settings, page 10-64](#)—Complete this procedure as needed.

NTP-G76 Verify Optical Span Loss Using CTC

Purpose	This procedure verifies the span loss between two DWDM nodes using Cisco Transport Controller (CTC). Perform this procedure after a node or network modification has occurred and you want to verify that the span loss between the nodes has not changed.
Tools/Equipment	None
Prerequisite Procedures	All procedures in Chapter 6, “Turn Up a Network.”
Required/As Needed	As needed
Onsite/Remote	Onsite or remote
Security Level	Superuser



Note

Using CTC to verify span loss is faster than a span loss measurement using an optical time domain reflectometer (OTDR) and does not require fibers to be removed. However, the resolution is not as precise as an OTDR measurement.

- Step 1** Complete the [“DLP-G46 Log into CTC” task on page 2-25](#). If you are already logged in, continue with Step 2.
- Step 2** In node view (single-shelf mode) or multishelf view (multishelf mode), click the **Provisioning > Comm Channels > OSC** tabs. Verify that two OSC terminations are provisioned and have an In-Service and Normal (IS-NR) (ANSI) or Unlocked-enabled (ETSI) service state.
- Step 3** Click the **Maintenance > DWDM > WDM Span Check** tabs.
- Step 4** Click **Retrieve Span Loss Values** to retrieve the latest span loss data.
- Step 5** View the following information:
 - Side—Shows the side to which the span loss values apply, either east or west.

- **Min Expected Span Loss (dBm)**—Shows the expected minimum span loss (in dBm). You can change the minimum by entering a new value in the field.
- **Meas Span Loss (dBm)**—Shows the measured span loss (in dBm).
- **Max Expected Span Loss (dBm)**—Shows the expected maximum span loss (in dBm). You can change the minimum by entering a new value in the field.



Note The minimum and maximum expected span loss values are calculated by Cisco MetroPlanner and imported to the node when you perform the [“NTP-G143 Import the Cisco MetroPlanner NE Update Configuration File”](#) task on page 3-38.

- **Resolution (dBm)**—Shows the resolution of the span loss measurement (in dBm):
 - +/- 1.5 dB for measured span losses between 0 and 25 dB
 - +/- 2.5 dB for measured span losses between 25 and 38 dB

Step 6 If the measured span loss is not between the minimum and maximum expected span loss, contact your site planner for further instructions.

Stop. You have completed this procedure.

NTP-G77 Manage Automatic Power Control

Purpose	This procedure manages the DWDM APC.
Tools/Equipment	None
Prerequisite Procedures	All procedures in the following chapters: Chapter 3, “Turn Up a Node” Chapter 6, “Turn Up a Network”
Required/As Needed	As needed
Onsite/Remote	Onsite or remote
Security Level	Superuser

Step 1 Complete the [“DLP-G46 Log into CTC”](#) task on page 2-25. If you are already logged in, continue with Step 2.

Step 2 Complete the following tasks as necessary:

- [DLP-G157 Disable Automatic Power Control](#), page 10-4
- [DLP-G158 Enable Automatic Power Control](#), page 10-4
- [DLP-G159 Refresh Automatic Power Control Information](#), page 10-5

Stop. You have completed this procedure.

DLP-G157 Disable Automatic Power Control

Purpose	This task disables the DWDM APC.
Tools/Equipment	None
Prerequisite Procedures	DLP-G46 Log into CTC, page 2-25
Required/As Needed	As needed
Onsite/Remote	Onsite or remote
Security Level	Superuser



Caution

Disable APC only to perform specific troubleshooting or node provisioning tasks. Always enable APC as soon as the tasks are completed. Leaving APC disabled can cause traffic loss.

-
- Step 1** In node view (single-shelf mode) or multishelf view (multishelf mode), click the **Maintenance > DWDM > APC** tabs.
 - Step 2** Click **Disable APC**.
 - Step 3** In the confirmation dialog box, Click **Yes**.
 - Step 4** In the status area, verify that the Check APC State status changes to Disable.
 - Step 5** Return to your originating procedure (NTP).
-

DLP-G158 Enable Automatic Power Control

Purpose	This task enables the DWDM APC.
Tools/Equipment	None
Prerequisite Procedures	DLP-G46 Log into CTC, page 2-25
Required/As Needed	As needed
Onsite/Remote	Onsite or remote
Security Level	Superuser



Caution

Disable APC only to perform specific troubleshooting or node provisioning tasks. Always enable APC as soon as the tasks are completed. Leaving APC disabled can cause traffic loss.

-
- Step 1** In node view (single-shelf mode) or multishelf view (multishelf mode), click the **Maintenance > DWDM > APC** tabs.
 - Step 2** Click **Enable APC**.
 - Step 3** In the confirmation dialog box, Click **Yes**.
 - Step 4** In the status area, verify that the Check APC State status changes to Disable.
 - Step 5** Return to your originating procedure (NTP).
-

DLP-G159 Refresh Automatic Power Control Information

Purpose	This task refreshes the DWDM APC information.
Tools/Equipment	A node provisioning plan prepared by Cisco MetroPlanner is required.
Prerequisite Procedures	DLP-G46 Log into CTC, page 2-25
Required/As Needed	As needed
Onsite/Remote	Onsite or remote
Security Level	Superuser

-
- Step 1** In node view (single-shelf mode) or multishelf view (multishelf mode), click the **Maintenance > DWDM > APC** tabs.
- Step 2** Click **Refresh**.
- Step 3** Return to your originating procedure (NTP).
-

NTP-G78 View ROADM Node Power Equalization

Purpose	This procedure allows you to view ROADM node power equalization levels.
Tools/Equipment	None
Prerequisite Procedures	DLP-G46 Log into CTC, page 2-25
Required/As Needed	As needed
Onsite/Remote	Onsite or remote
Security Level	Superuser

-
- Step 1** Complete the “[DLP-G46 Log into CTC](#)” task on page 2-25. If you are already logged in, continue with Step 2.
- Step 2** In node view (single-shelf mode) or multishelf view (multishelf mode), click the **Maintenance > DWDM > ROADM Power Monitoring** tabs.
- Step 3** On the Power Monitoring tab, view the following east-to-west (E > W) and west-to-east (W > E) power information:
- Padd—Add power. This power level is represented by the red bar.
 - Ppt—Pass-through power. This power level is represented by the yellow bar.
 - Pout—Output power. This power level is represented by the blue bar. It shows the per-channel (wavelength) power at the 32WSS output (COM_TX) port.



Note The 32WSS and 32WSS-L cards are designed to handle minor differences in output power. The output power does not need to be exactly the same for all wavelengths.

[Figure 10-1](#) shows an example of ROADM node with equalized output power.

Figure 10-1 Equalized ROADM Power Example

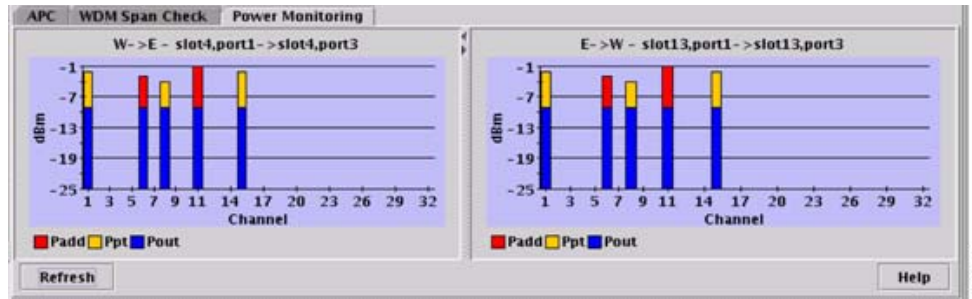

- Step 4** If needed, click **Refresh** to update the display.
Stop. You have completed this procedure.

NTP-G80 Change Node Management Information

Purpose	This procedure changes the node name, date, time, contact information, and login legal disclaimer.
Tools/Equipment	None
Prerequisite Procedures	NTP-G24 Set Up Name, Date, Time, and Contact Information , page 3-10
Required/As Needed	As needed
Onsite/Remote	Onsite or remote
Security Level	Provisioning or higher

- Step 1** Complete the “[DLP-G46 Log into CTC](#)” task on page 2-25. If you are already logged in, continue with Step 2.
- Step 2** Complete the “[NTP-G103 Back Up the Database](#)” procedure on page 13-2.
- Step 3** In node view (single-shelf mode) or multishelf view (multishelf mode), click the **Provisioning > General** tabs.
- Step 4** Complete the “[DLP-G160 Change the Node Name, Date, Time, and Contact Information](#)” task on page 10-7, as needed.
- Step 5** Complete the “[DLP-G161 Change the Login Legal Disclaimer](#)” task on page 10-8, as needed.
- Step 6** After confirming the changes, complete the “[NTP-G103 Back Up the Database](#)” procedure on page 13-2.
- Stop.** You have completed this procedure.

DLP-G160 Change the Node Name, Date, Time, and Contact Information

Purpose	This task changes basic information such as node name, date, time, and contact information.
Tools/Equipment	None
Prerequisite Procedures	DLP-G46 Log into CTC, page 2-25
Required/As Needed	As needed
Onsite/Remote	Onsite or remote
Security Level	Provisioning or higher



Caution

Changing the date, time, or time zone might invalidate the node's performance monitoring counters.

Step 1 In node view (single-shelf mode) or multishelf view (multishelf mode), click the **Provisioning > General** tabs.

Step 2 Change any of the following:

- General: Node Name
- General: Contact
- Location: Latitude
- Location: Longitude
- Location: Description



Note

To see changes to longitude or latitude on the network map, you must go to network view and right-click the specified node, then click **Reset Node Position**.

- Time: Use NTP/SNTP Server
- Time: NTP/SNTP Server IP Address (if Use NTP/SNTP Server is checked)
- Time: Date (M/D/Y)
- Time: Time (H:M:S)
- Time: Time Zone
- Time: Use Daylight Saving Time
- AIS-V Insertion On STS-1 Signal Degrade - Path: Insert AIS-V on STS-1 SD-P
- AIS-V Insertion On STS-1 Signal Degrade - Path: SD-P BER

See the “[NTP-G24 Set Up Name, Date, Time, and Contact Information](#)” procedure on page 3-10 for detailed field descriptions.

Step 3 Click **Apply**.

Step 4 Return to your originating procedure (NTP).

DLP-G161 Change the Login Legal Disclaimer

Purpose	This task modifies the legal disclaimer statement shown in the CTC login dialog box so that it will display customer-specific information when users log into the network.
Tools/Equipment	None
Prerequisite Procedures	DLP-G46 Log into CTC, page 2-25
Required/As Needed	As needed
Onsite/Remote	Onsite or remote
Security Level	Superuser

-
- Step 1** In node view (single-shelf mode) or multishelf view (multishelf mode), click the **Provisioning > Security > Legal Disclaimer > HTML** tabs.
- Step 2** The existing statement is a default, non-customer-specific disclaimer. If you want to edit this statement with specifics for your company, you can change the text. Use the HTML commands in [Table 10-1](#) to format the text, as needed.

Table 10-1 *HTML Commands for the Legal Disclaimer*

Command	Description
	Begins boldface font
	Ends boldface font
<center>	Aligns type in the center of the window
</center>	Ends the center alignment
<font= <i>n</i> > (where <i>n</i> = font point size)	Changes the font to the new size
	Ends the font size command
<p>	Creates a line break
<sub>	Begins subscript
</sub>	Ends subscript
<sup>	Begins superscript
</sup>	Ends superscript
<u>	Begins underline
</u>	Ends underline

- Step 3** If you want to preview your changed statement and formatting, click the **Preview** subtab.
- Step 4** Click **Apply**.
- Step 5** Return to your originating procedure (NTP).
-

NTP-G134 Modify OSI Provisioning

Purpose	This procedure modifies the ONS 15454 OSI parameters including the OSI routing mode, TARP, routers, subnets, and IP-over-CLNS tunnels.
Tools/Equipment	None
Prerequisite Procedures	NTP-G132 Provision OSI, page 3-27
Required/As Needed	As needed
Onsite/Remote	Onsite or remote
Security Level	Provisioning or higher

Note

Additional information about the ONS 15454 implementation of OSI is provided in the “Management Network Connectivity” chapter of the *Cisco ONS 15454 DWDM Reference Manual*.

-
- Step 1** Complete the “[DLP-G46 Log into CTC](#)” task on page 2-25. If you are already logged in, continue with Step 2.
- Step 2** Complete the “[NTP-G103 Back Up the Database](#)” procedure on page 13-2.
- Step 3** Perform any of the following tasks as needed:
- [DLP-G284 Modify the TARP Operating Parameters, page 10-10](#)
 - [DLP-G285 Add a Static TID to NSAP Entry to the TARP Data Cache, page 3-31](#)
 - [DLP-G286 Remove a Static TID to NSAP Entry from the TARP Data Cache, page 10-12](#)
 - [DLP-G287 Add a TARP Manual Adjacency Table Entry, page 10-12](#)
 - [DLP-G292 Remove a TARP Manual Adjacency Table Entry, page 10-13](#)
 - [DLP-G293 Change the OSI Routing Mode, page 10-14](#)
 - [DLP-G294 Edit the OSI Router Configuration, page 10-15](#)
 - [DLP-G295 Edit the OSI Subnetwork Point of Attachment, page 10-16](#)
 - [DLP-G296 Edit an IP-Over-CLNS Tunnel, page 10-17](#)
 - [DLP-G297 Delete an IP-Over-CLNS Tunnel, page 10-18](#)
- Step 4** Complete the “[NTP-G103 Back Up the Database](#)” procedure on page 13-2.
- Stop. You have completed this procedure.**
-

DLP-G284 Modify the TARP Operating Parameters

Purpose	This task modifies the TARP operating parameters including TARP protocol data unit (PDU) propagation, timers, and loop detection buffer (LDB).
Tools/Equipment	None
Prerequisite Procedures	DLP-G46 Log into CTC, page 2-25
Required/As Needed	As needed
Onsite/Remote	Onsite or remote
Security Level	Superuser

Step 1 In node view (single-shelf mode) or multishelf view (multishelf mode), click the **Provisioning > OSI > TARP > Config** tabs.

Step 2 Provision the following parameters, as needed:

- TARP PDUs L1 Propagation—If checked (default), TARP Type 1 PDUs that are received by the node and are not excluded by the LDB are propagated to other NEs within the Level 1 OSI area. (Type 1 PDUs request a protocol address that matches a target identifier [TID] within a Level 1 routing area.) The propagation does not occur if the NE is the target of the Type 1 PDU, and PDUs are not propagated to the NE from which the PDU was received.



Note The TARP PDUs L1 Propagation parameter is not used when the Node Routing Area (Provisioning > OSI > Main Setup tab) is set to End System.

- TARP PDUs L2 Propagation—If checked (default), TARP Type 2 PDUs received by the node that are not excluded by the LDB are propagated to other NEs within the Level 2 OSI areas. (Type 2 PDUs request a protocol address that matches a TID within a Level 2 routing area.) The propagation does not occur if the NE is the target of the Type 2 PDU, and PDUs are not propagated to the NE from which the PDU was received.



Note The TARP PDUs L2 Propagation parameter is only used when the Node Routing Area is provisioned to Intermediate System Level 1/Level 2.

- TARP PDUs Origination—If checked (default), the node performs all TARP origination functions including:
 - TID to Network Service Access Point (NSAP) resolution requests (originate TARP Type 1 and Type 2 PDUs)
 - NSAP to TID requests (originate Type 5 PDUs)
 - TARP address changes (originate Type 4 PDUs)



Note TARP Echo and NSAP to TID are not supported.

- TARP Data Cache—If checked (default), the node maintains a TARP data cache (TDC). The TDC is a database of TID-to-NSAP pairs created from TARP Type 3 PDUs that are received by the node and modified by TARP Type 4 PDUs (TID-to-NSAP updates or corrections). TARP 3 PDUs are responses to Type 1 and Type 2 PDUs. The TDC can also be populated with static entries entered on the TARP > Static TDC tab.



Note This parameter is only used when the TARP PDUs Origination parameter is enabled.

- L2 TARP Data Cache—If checked (default), the TIDs and NSAPs of NEs originating Type 2 requests are added to the TDC before the node propagates the requests to other NEs.



Note The L2 TARP Data Cache parameter is designed for Intermediate System Level 1/Level 2 nodes that are connected to other Intermediate System Level 1/Level 2 nodes. Enabling the parameter for Intermediate System Level 1 nodes is not recommended.

- LDB—If checked (default), enables the TARP loop detection buffer. The LDB prevents TARP PDUs from being sent more than once on the same subnet.



Note The LDB parameter is not used if the Node Routing Mode is provisioned to End System or if the TARP PDUs L1 Propagation parameter is not enabled.

- LAN TARP Storm Suppression—If checked (default), enables TARP storm suppression. This function prevents redundant TARP PDUs from being unnecessarily propagated across the LAN network.
- Send Type 4 PDU on Startup—If checked, a TARP Type 4 PDU is originated during the initial ONS 15454 startup. Type 4 PDUs indicate that a TID or NSAP change has occurred at the NE. (The default setting is not enabled.)
- Type 4 PDU Delay—Sets the amount of time that will pass before the Type 4 PDU is generated when Send Type 4 PDU on Startup is enabled. 60 seconds is the default. The range is 0 to 255 seconds.



Note The Send Type 4 PDU on Startup and Type 4 PDU Delay parameters are not used if the TARP PDUs Origination parameter is not enabled.

- LDB Entry—Sets the TARP loop detection buffer timer. The LDB buffer time is assigned to each LDB entry for which the TARP sequence number (tar-seq) is zero. The default is 5 minutes. The range is 1 to 10 minutes.
- LDB Flush—Sets the frequency period for flushing the LDB. The default is 5 minutes. The range is 0 to 1440 minutes.
- T1—Sets the amount of time to wait for a response to a Type 1 PDU. Type 1 PDUs seek a specific NE TID within an OSI Level 1 area. The default is 15 seconds. The range is 0 to 3600 seconds.
- T2—Sets the amount of time to wait for a response to a Type 2 PDU. TARP Type 2 PDUs seek a specific NE TID value within OSI Level 1 and Level 2 areas. The default is 25 seconds. The range is 0 to 3600 seconds.
- T3—Sets the amount of time to wait for an address resolution request. The default is 40 seconds. The range is 0 to 3600 seconds.

- T4—Sets the amount of time to wait for an error recovery. This timer begins after the T2 timer expires without finding the requested NE TID. The default is 20 seconds. The range is 0 to 3600 seconds.



Note The T1, T2, and T4 timers are not used if TARP PDUs Origination is not enabled.

- Step 3** Click **Apply**.
- Step 4** Return to your originating procedure (NTP).

DLP-G286 Remove a Static TID to NSAP Entry from the TARP Data Cache

Purpose	This task removes a static TID to NSAP entry from the TDC.
Tools/Equipment	None
Prerequisite Procedures	DLP-G46 Log into CTC, page 2-25
Required/As Needed	As needed
Onsite/Remote	Onsite or remote
Security Level	Provisioner or higher

- Step 1** In node view (single-shelf mode) or multishelf view (multishelf mode), click the **Provisioning > OSI > TARP > Static TDC** tabs.
- Step 2** Click the static entry that you want to delete.
- Step 3** Click **Delete Static Entry**.
- Step 4** In the Delete TDC Entry dialog box, click **Yes**.
- Step 5** Return to your originating procedure (NTP).

DLP-G287 Add a TARP Manual Adjacency Table Entry

Purpose	This task adds an entry to the TARP manual adjacency table (MAT). Entries are added to the MAT when the ONS 15454 must communicate across routers or non-SONET NEs that lack TARP capability.
Tools/Equipment	None
Prerequisite Procedures	DLP-G46 Log into CTC, page 2-25
Required/As Needed	As needed
Onsite/Remote	Onsite or remote
Security Level	Provisioning or higher

- Step 1** In the node view (single-shelf mode) or multishelf view (multishelf mode), click the **Provisioning > OSI > TARP > MAT** tabs.

- Step 2** Click **Add**.
- Step 3** In the Add TARP Manual Adjacency Table Entry dialog box, enter the following:
- **Level**—Sets the TARP Type Code that will be sent:
 - **Level 1**—Indicates that the adjacency is within the same area as the current node. The entry generates Type 1 PDUs.
 - **Level 2**—Indicates that the adjacency is in a different area from the current node. The entry generates Type 2 PDUs.
 - **NSAP**—Enter the OSI NSAP address in the NSAP field or, if preferred, click **Use Mask** and enter the address in the Masked NSAP Entry dialog box.
- Step 4** Click **OK** to close the Masked NSAP Entry dialog box, if used, and then click **OK** to close the Add Static Entry dialog box.
- Step 5** Return to your originating procedure (NTP).
-

DLP-G292 Remove a TARP Manual Adjacency Table Entry

Purpose	This task removes an entry from the TARP MAT.
Tools/Equipment	None
Prerequisite Procedures	DLP-G46 Log into CTC, page 2-25
Required/As Needed	As needed
Onsite/Remote	Onsite or remote
Security Level	Provisioning or higher



Caution

If TARP manual adjacency is the only means of communication to a group of nodes, loss of visibility will occur when the adjacency table entry is removed.

- Step 1** In node view (single-shelf mode) or multishelf view (multishelf mode), click the **Provisioning > OSI > TARP > MAT** tabs.
- Step 2** Click the MAT entry that you want to delete.
- Step 3** Click **Remove**.
- Step 4** In the Delete TDC Entry dialog box, click **OK**.
- Step 5** Return to your originating procedure (NTP).
-

DLP-G293 Change the OSI Routing Mode

Purpose	This task changes the OSI routing mode.
Tools/Equipment	None
Prerequisite Procedures	DLP-G46 Log into CTC, page 2-25
Required/As Needed	As needed
Onsite/Remote	Onsite or remote
Security Level	Provisioning or higher



Caution

Do not complete this procedure until you confirm the role of the node within the network. It will be either an ES, IS Level 1, or IS Level 1/Level 2. This decision must be carefully considered. For additional information about OSI provisioning, refer to the “Management Network Connectivity” chapter of the *Cisco ONS 15454 DWDM Reference Manual*.



Caution

Link state PDU (LSP) buffers must be the same at all NEs within the network, or loss of visibility could occur. Do not modify the LSP buffers unless you are sure that all NEs within the OSI have the same buffer size.



Caution

LSP buffer sizes cannot be greater than the LAP-D MTU size within the OSI area.

Step 1

Verify the following:

- All L1/L2 virtual routers on the NE must reside in the same area. This means that all neighboring virtual routers must have at least one common area address.
- For OSI L1/L2 to ES routing mode changes, only one L1/L2 virtual router and no more than one subnet can be configured.
- For OSI L1 to ES routing mode changes, only one L1 virtual router and no more than one subnet can be configured.

Step 2

In node view (single-shelf mode) or multishelf view (multishelf mode), click the **Provisioning > OSI > Main Setup** tabs.

Step 3

Choose one of the following node routing modes:

- **End System**—The ONS 15454 performs OSI IS functions. It communicates with IS and ES nodes that reside within its OSI area. It depends upon an IS L1/L2 node to communicate with IS and ES nodes that reside outside its OSI area.
- **Intermediate System Level 1**—The ONS 15454 performs IS functions. It communicates with IS and ES nodes that reside within its OSI area. It does not communicate with IS nodes that reside in other OSI areas except through an IS L1/L2 node residing in its own area.
- **Intermediate System Level 1/Level 2**—The ONS 15454 performs IS functions. It communicates with IS and ES nodes that reside within its OSI area. It also communicates with IS L1/L2 nodes that reside in other OSI areas. Before choosing this option, verify the following:
 - The node is connected to another IS Level 1/Level 2 node that resides in a different OSI area.
 - The node is connected to all nodes within its area that are provisioned as IS L1/L2.



Note Changing a routing mode should be carefully considered. Additional information about OSI ESs and ISs and the ES-IS and IS-IS protocols are provided in the “Management Network Connectivity” chapter of the *Cisco ONS 15454 DWDM Reference Manual*.

- Step 4** Although Cisco does not recommend changing the LSP buffer sizes, you can adjust the buffers in the following fields:
- L1 LSP Buffer Size—Adjusts the Level 1 link state PDU buffer size.
 - L2 LSP Buffer Size—Adjusts the Level 2 link state PDU buffer size.
- Step 5** Return to your originating procedure (NTP).

DLP-G294 Edit the OSI Router Configuration

Purpose	This task allows you to edit the OSI router configuration, including enabling and disabling OSI routers, editing the primary area address, and creating or editing additional area addresses.
Tools/Equipment	None
Prerequisite Procedures	DLP-G46 Log into CTC, page 2-25
Required/As Needed	As needed
Onsite/Remote	Onsite or remote
Security Level	Provisioning or higher

- Step 1** Click the **Provisioning > OSI > Routers > Setup** tabs.
- Step 2** Choose the router you want provision and click **Edit**.
- Step 3** In the OSI Router Editor dialog box:
- Check or uncheck the Enabled box to enable or disable the router.



Note Router 1 must be enabled before you can enable Routers 2 and 3.

- For enabled routers, edit the primary area address, if needed. The address can be between 8 and 24 alphanumeric characters in length.
 - If you want to add or edit an area address to the primary area, enter the address at the bottom of the Multiple Area Addresses area. The area address can be 2 to 26 numeric characters (0–9) in length. Click **Add**.
 - Click **OK**.
- Step 4** Return to your originating procedure (NTP).

DLP-G295 Edit the OSI Subnetwork Point of Attachment

Purpose	This task allows you to view and edit the OSI subnetwork point of attachment parameters. The parameters are initially provisioned when you create a section data communications channel (SDCC) (ANSI) or regeneration section (RS-DCC) (ETSI), Line data communications channel (LDCC) (ANSI) or multiplex section (MS-DCC) (ETSI), generic communications channel (GCC), or optical service channel (OSC), or when you enable the LAN subnet.
Tools/Equipment	None
Prerequisite Procedures	DLP-G46 Log into CTC, page 2-25
Required/As Needed	As needed
Onsite/Remote	Onsite or remote
Security Level	Provisioning or higher

-
- Step 1** If the subnet router is not enabled, complete “[DLP-G294 Edit the OSI Router Configuration](#)” task on [page 10-15](#) to enable it. If it is enabled, continue with [Step 2](#).
- Step 2** In the node view (single-shelf mode) or multishelf view (multishelf mode), click the **Provisioning > OSI > Routers > Subnet** tabs.
- Step 3** Choose the subnet you want to edit, then click **Edit**.
- Step 4** In the Edit <subnet type> Subnet <slot/port> dialog box, edit the following fields:
- ESH—The End System Hello (ESH) PDU propagation frequency. An end system NE transmits ESHs to inform other ESs and ISs about the NSAPs it serves. The default is 10 seconds. The range is 10 to 1000 seconds.
 - ISH—The Intermediate System Hello (ISH) PDU propagation frequency. An intermediate system NE sends ISHs to other ESs and ISs to inform them about the NEs it serves. The default is 10 seconds. The range is 10 to 1000 seconds.
 - IIH—The Intermediate System to Intermediate System Hello (IIH) PDU propagation frequency. The IS-IS Hello PDUs establish and maintain adjacencies between ISs. The default is 3 seconds. The range is 1 to 600 seconds.
-  **Note** The IS-IS Cost and DIS Priority parameters are provisioned when you create or enable a subnet. You cannot change the parameters after the subnet is created. To change the DIS Priority and IS-IS Cost parameters, delete the subnet and create a new one.
-
- Step 5** Click **OK**.
- Step 6** Return to your originating procedure (NTP).
-

DLP-G296 Edit an IP-Over-CLNS Tunnel

Purpose	This task allows you to edit the parameters of an IP-over-CLNS tunnel.
Tools/Equipment	None
Prerequisite Procedures	DLP-G291 Create an IP-Over-CLNS Tunnel, page 3-35 DLP-G46 Log into CTC, page 2-25
Required/As Needed	As needed
Onsite/Remote	Onsite or remote
Security Level	Provisioning or higher



Caution

Changing the IP or NSAP addresses on an IP-over-CLNS tunnel can cause loss of NE visibility or NE isolation. Do not change network addresses until you verify the changes with your network administrator.

Step 1 Click the **Provisioning > OSI > Tunnels** tabs.

Step 2 Click **Edit**.

Step 3 In the Edit IP Over OSI Tunnel dialog box, complete the following fields:

- Tunnel Type—Edit the tunnel type:
 - **Cisco**—Creates the proprietary Cisco IP tunnel. Cisco IP tunnels add the CLNS header to the IP packets.
 - **GRE**—Creates a generic routing encapsulation (GRE). GRE tunnels add the CLNS header and a GRE header to the IP packets.

The Cisco proprietary tunnel is slightly more efficient than the GRE tunnel because it does not add the GRE header to each IP packet. The two tunnel types are not compatible. Most Cisco routers support the Cisco IP tunnel, while only a few support both GRE and Cisco IP tunnels. You generally should create Cisco IP tunnels if you are tunneling between two Cisco routers or between a Cisco router and an ONS node.



Caution

Always verify that the IP-over-CLNS tunnel type you choose is supported by the equipment at the other end of the tunnel.

- IP Address—Enter the IP address of the IP-over-CLNS tunnel destination.
- IP Mask—Enter the IP address subnet mask of the IP-over-CLNS destination.
- OSPF Metric—Enter the Open Shortest Path First (OSPF) metric for sending packets across the IP-over-CLNS tunnel. The OSPF metric, or cost, is used by OSPF routers to calculate the shortest path. The default is 110. Normally, it is not changed unless you are creating multiple tunnel routes and want to prioritize routing by assigning different metrics.
- NSAP Address—Enter the destination NE or OSI router NSAP address.

Step 4 Click **OK**.

Step 5 Return to your originating procedure (NTP).

DLP-G297 Delete an IP-Over-CLNS Tunnel

Purpose	This task allows you to delete an IP-over-CLNS tunnel.
Tools/Equipment	None
Prerequisite Procedures	DLP-G46 Log into CTC, page 2-25
Required/As Needed	As needed
Onsite/Remote	Onsite or remote
Security Level	Provisioning or higher



Caution

Deleting an IP-over-CLNS tunnel might cause the nodes to lose visibility or cause node isolation. If node isolation occurs, onsite provisioning might be required to regain connectivity. Always confirm tunnel deletions with your network administrator.

-
- Step 1** Click the **Provisioning > OSI > Tunnels** tabs.
- Step 2** Choose the IP-over-CLNS tunnel that you want to delete.
- Step 3** Click **Delete**.
- Step 4** Click **OK**.
- Step 5** Return to your originating procedure (NTP).
-

NTP-G81 Change CTC Network Access

Purpose	This procedure changes or deletes network information, including IP settings, static routes, OSPF options, proxy tunnels, and firewall tunnels.
Tools/Equipment	None
Prerequisite Procedures	NTP-G26 Set Up CTC Network Access, page 3-13
Required/As Needed	As needed
Onsite/Remote	Onsite or remote
Security Level	Provisioning or higher



Note

Additional ONS 15454 networking information, including IP addressing examples, dual IP addressing (secure mode) information, static route scenarios, OSPF protocol information, and Routing Information Protocol (RIP) options are provided in the “Management Network Connectivity” chapter in the *Cisco ONS 15454 DWDM Reference Manual*.

-
- Step 1** Complete the “[DLP-G46 Log into CTC](#)” task on page 2-25. If you are already logged in, continue with Step 2.
- Step 2** Complete the “[NTP-G103 Back Up the Database](#)” procedure on page 13-2.
- Step 3** Perform any of the following tasks as needed:
- [DLP-G162 Change IP Settings, page 10-19](#)

- [DLP-G265 Lock Node Security](#), page 10-20
- [DLP-G266 Modify Backplane Port IP Settings in Security Mode](#), page 10-21
- [DLP-G267 Disable Node Security Mode](#), page 10-22
- [DLP-G163 Modify a Static Route](#), page 10-23
- [DLP-G164 Delete a Static Route](#), page 10-24
- [DLP-G165 Disable OSPF](#), page 10-24
- [DLP-G59 Set Up or Change Open Shortest Path First Protocol](#), page 3-21
- [DLP-G166 Delete a Proxy Tunnel](#), page 10-25
- [DLP-G167 Delete a Firewall Tunnel](#), page 10-25

Step 4 Complete the “[NTP-G103 Back Up the Database](#)” procedure on page 13-2.

Stop. You have completed this procedure.

DLP-G162 Change IP Settings

Purpose	This task changes the IP address, subnet mask, default router, Dynamic Host Configuration Protocol (DHCP) access, firewall Internet Inter-Object Request Broker Protocol (IIOP) listener port, LCD IP display, and proxy server settings.
Tools/Equipment	None
Prerequisite Procedures	DLP-G46 Log into CTC , page 2-25 DLP-G56 Provision IP Settings , page 3-14
Required/As Needed	As needed
Onsite/Remote	Onsite or remote
Security Level	Superuser



Caution

Changing the node IP address, subnet mask, or IIOP listener port causes the TCC2/TCC2P cards to reboot. If Ethernet circuits using Spanning Tree Protocol (STP) originate or terminate on E-Series Ethernet cards installed in the node, circuit traffic will be lost for several minutes while the spanning trees reconverge. Other circuits are not affected by TCC2/TCC2P reboots.

Step 1 In node view (single-shelf mode) or multishelf view (multishelf mode), click the **Provisioning > Network > General** tabs.

Step 2 Change any of the following, as required:

- IP Address
- Net/Subnet Mask Length
- Default Router
- LCD Setting
- Suppress CTC IP Display
- Forward DHCP Request To

Gateway Settings

- Enable SOCKS proxy on Port. If enabled, one of the following:
 - External Network Element
 - Gateway Network Element
 - SOCK Proxy only

See the “[DLP-G56 Provision IP Settings](#)” task on page 3-14 for detailed field descriptions.

Step 3 Click **Apply**.

If you changed a network field that will cause the node to reboot, such as the IP address, or subnet mask, the Change Network Configuration confirmation dialog box appears. If you changed a gateway setting, a confirmation appropriate to the gateway field appears.

Step 4 If a confirmation dialog box appears, click **Yes**.

If you changed an IP address, subnet mask length, both ONS 15454 TCC2/TCC2P cards reboot, one at a time. A TCC2/TCC2P card reboot causes a temporary loss of connectivity to the node, but traffic is unaffected.

Step 5 Confirm that the changes appear on the Provisioning > Network > General tabs. If not, refer to the *Cisco ONS 15454 DWDM Troubleshooting Guide*.**Step 6** Return to your originating procedure (NTP).

DLP-G265 Lock Node Security

Purpose	This task locks the ONS 15454 security mode. When security mode is locked, two IP addresses must always be provisioned for the node, one for the TCC2P LAN (TCP/IP) port, and one for the backplane LAN port.
Tools/Equipment	TCC2P cards must be installed.
Prerequisite Procedures	DLP-G46 Log into CTC, page 2-25 DLP-G264 Enable Node Security Mode, page 3-18
Required/As Needed	As needed
Onsite/Remote	Onsite or remote
Security Level	Superuser

**Caution**

When a node is locked, it cannot be unlocked by any user or action. It can only be changed by Cisco Technical Support. Even if the node’s database is deleted and another unlocked database is loaded, the node will remain locked. Do not proceed unless you want the node to permanently retain the current secure configuration including dual IP addresses.

**Note**

The options in this task are available only when TCC2P cards are installed.

Step 1 In node view (single-shelf mode) or multishelf view (multishelf mode), click the **Provisioning > Security > Data Comm** tabs.

- Step 2** Click **Lock**.
- Step 3** In the Confirm Lock Secure Mode dialog box, click **Yes**.
- Step 4** Return to your originating procedure (NTP).

DLP-G266 Modify Backplane Port IP Settings in Security Mode

Purpose	This task modifies the ONS 15454 backplane IP address, subnet mask, and default router when security mode is enabled. It also modifies settings that control backplane IP address visibility in CTC and the ONS 15454 LCD.
Tools/Equipment	TCC2P cards must be installed.
Prerequisite Procedures	NTP-G103 Back Up the Database, page 13-2 DLP-G46 Log into CTC, page 2-25 DLP-G264 Enable Node Security Mode, page 3-18
Required/As Needed	As needed
Onsite/Remote	Onsite or remote
Security Level	Superuser



Caution

Provisioning an IP address that is incompatible with the ONS 15454 network might be service affecting.



Caution

This task cannot be performed on a secure mode NE that has been locked.



Note

The options in this task are available only when TCC2P cards are installed.

- Step 1** Click the **Provisioning > Security > Data Comm** tabs.
- Step 2** Modify the following fields, as necessary:
- IP Address
 - Subnet Mask
 - Default Router
 - LCD IP Setting—choose one of the following:
 - **Allow Configuration**—Displays the backplane IP address on the LCD and allows it to be changed using the LCD buttons.
 - **Display only**—Displays the backplane IP address on the LCD but does not allow it to be changed using the LCD buttons.
 - **Suppress Display**—Suppresses the display of the IP address on the LCD.
 - Suppress CTC IP Address—If checked, suppresses the IP address from display on the Data Comm subtab, CTC node view or multishelf view information area, and other locations.
- Step 3** Click **Apply**.

If you changed the IP address, subnet mask, or default router, the node will reboot. This will take 5 to 10 minutes.

Step 4 Return to your originating procedure (NTP).

DLP-G267 Disable Node Security Mode

Purpose	This task disables the ONS 15454 security mode and allows only one IP address to be provisioned for the backplane LAN port and the TCC2P LAN port.
Tools/Equipment	TCC2P cards must be installed.
Prerequisite Procedures	DLP-G46 Log into CTC, page 2-25 DLP-G264 Enable Node Security Mode, page 3-18
Required/As Needed	As needed
Onsite/Remote	Onsite or remote
Security Level	Superuser



Note

The node will reboot after you complete this task, causing a temporary disconnection between the CTC computer and the node.



Note

If you change an NE from secure mode to the default (repeater) mode, the backplane IP address becomes the node IP address.



Note

This task cannot be performed if the NE's security mode configuration is locked. If secure mode is locked, you must contact Cisco Technical Support to change the node configuration.



Note

The options in this task are only available when TCC2P cards are installed.

Step 1 Click the **Provisioning > Security > Data Comm** tabs.

Step 2 Click **Change Mode**.

Step 3 Review the information on the Change Secure Mode wizard page, then click **Next**.

Step 4 On the Node IP Address page, choose the address you want to assign to the node:

- **Backplane Ethernet Port**—Assigns the backplane IP address as the node IP address.
- **TCC Ethernet Port**—Assigns the TCC2P port IP address as the node IP address.
- **New IP Address**—Allows you to define a new IP address. If you choose this option, enter the new IP address, subnet mask, and default router IP address.

Step 5 Click **Next**.

Step 6 On the SOCKS Proxy Server Settings page, choose one of the following:

- **External Network Element (ENE)**—If selected, the CTC computer is only visible to the ONS 15454 to which the CTC computer is connected. The computer is not visible to the data communications channel (DCC)-connected nodes. In addition, firewall is enabled, which means that the node prevents IP traffic from being routed between the DCC and the LAN port.
- **Gateway Network Element (GNE)**—If selected, the CTC computer is visible to other DCC-connected nodes. The node prevents IP traffic from being routed between the DCC and the LAN port.
- **Proxy-only**—If selected, the ONS 15454 responds to CTC requests with a list of DCC-connected nodes for which the node serves as a proxy. The CTC computer is visible to other DCC-connected nodes. The node does not prevent traffic from being routed between the DCC and LAN port.

Step 7 Click **Finish**.

Within the next 30 to 40 seconds, the TCC2P cards reboot. CTC switches to network view, and the CTC Alerts dialog box appears. In network view, the node changes to gray and a DISCONNECTED condition appears.

Step 8 In the CTC Alerts dialog box, click **Close**. Wait for the reboot to finish. (This might take several minutes.)

Step 9 Return to your originating procedure (NTP).

DLP-G163 Modify a Static Route

Purpose	This task modifies a static route on an ONS 15454.
Tools/Equipment	None
Prerequisite Procedures	DLP-G46 Log into CTC, page 2-25 DLP-G58 Create a Static Route, page 3-20
Required/As Needed	As needed
Onsite/Remote	Onsite or remote
Security Level	Provisioning or higher

Step 1 In node view (single-shelf mode) or multishelf view (multishelf mode), click the **Provisioning > Network** tabs.

Step 2 Click the **Static Routing** tab.

Step 3 Click the static route you want to edit.

Step 4 Click **Edit**.

Step 5 In the Edit Selected Static Route dialog box, enter the following:

- Mask
- Next Hop
- Cost

See the “[DLP-G58 Create a Static Route](#)” task on page 3-20 for detailed field descriptions.

Step 6 Click **OK**.

Step 7 Return to your originating procedure (NTP).

DLP-G164 Delete a Static Route

Purpose	This task deletes an existing static route on an ONS 15454.
Tools/Equipment	None
Prerequisite Procedures	DLP-G46 Log into CTC, page 2-25 DLP-G58 Create a Static Route, page 3-20
Required/As Needed	As needed
Onsite/Remote	Onsite or remote
Security Level	Provisioning or higher

- Step 1** In node view (single-shelf mode) or multishelf view (multishelf mode), click the **Provisioning > Network > Static Routing** tabs.
- Step 2** Click the static route that you want to delete.
- Step 3** Click **Delete**. A confirmation dialog box appears.
- Step 4** Click **Yes**.
- Step 5** Return to your originating procedure (NTP).
-

DLP-G165 Disable OSPF

Purpose	This task disables the OSPF routing protocol process for an ONS 15454 LAN.
Tools/Equipment	None
Prerequisite Procedures	DLP-G46 Log into CTC, page 2-25 DLP-G59 Set Up or Change Open Shortest Path First Protocol, page 3-21
Required/As Needed	As needed
Onsite/Remote	Onsite or remote
Security Level	Provisioning or higher

- Step 1** In node view (single-shelf mode) or multishelf view (multishelf mode), click the **Provisioning > Network > OSPF** tabs. The OSPF subtab has several options.
- Step 2** In the OSPF on LAN area, uncheck the **OSPF active on LAN** check box.
- Step 3** Click **Apply**. Confirm that the changes appear.
- Step 4** Return to your originating procedure (NTP).
-

DLP-G166 Delete a Proxy Tunnel

Purpose	This task removes a proxy tunnel.
Tools/Equipment	None
Prerequisite Procedures	DLP-G97 Provision a Proxy Tunnel, page 7-24 DLP-G46 Log into CTC, page 2-25
Required/As Needed	As needed
Onsite/Remote	Onsite or remote
Security Level	Superuser

- Step 1** Click the **Provisioning > Network > Proxy** subtabs.
- Step 2** Click the proxy tunnel that you want to delete.
- Step 3** Click **Delete**.
- Step 4** Continue with your originating procedure (NTP).
-

DLP-G167 Delete a Firewall Tunnel

Purpose	This task removes a firewall tunnel.
Tools/Equipment	None
Prerequisite Procedures	DLP-G98 Provision a Firewall Tunnel, page 7-25 DLP-G46 Log into CTC, page 2-25
Required/As Needed	As needed
Onsite/Remote	Onsite or remote
Security Level	Superuser

- Step 1** Click the **Provisioning > Network > Firewall** subtabs.
- Step 2** Click the firewall tunnel that you want to delete.
- Step 3** Click **Delete**.
- Step 4** Return to your originating procedure (NTP).
-

NTP-G82 Customize the CTC Network View

Purpose	This procedure modifies the CTC network view, including grouping nodes into domains for a less-cluttered display, changing the network view background color, and using a custom image for the network view background.
Tools/Equipment	None
Prerequisite Procedures	None
Required/As Needed	As needed
Onsite/Remote	Onsite or remote
Security Level	Superuser

Step 1 Complete the “[DLP-G46 Log into CTC](#)” task on page 2-25. If you are already logged in, continue with Step 2.

Step 2 Complete the following tasks, as needed:

- [DLP-G168 Change the Network View Background Color](#), page 10-26
- [DLP-G169 Change the Default Network View Background Map](#), page 10-27
- [DLP-G170 Apply a Custom Network View Background Map](#), page 10-28
- [DLP-G171 Create Domain Icons](#), page 10-28
- [DLP-G172 Manage Domain Icons](#), page 10-29
- [DLP-G173 Enable Dialog Box Do-Not-Display Option](#), page 10-30
- [DLP-G174 Switch Between TDM and DWDM Network Views](#), page 10-31
- [DLP-G330 Consolidate Links in Network View](#), page 10-31

Stop. You have completed this procedure.

DLP-G168 Change the Network View Background Color

Purpose	This task changes the network view background color or the domain view background color (the area displayed when you open a domain).
Tools/Equipment	None
Prerequisite Procedures	DLP-G46 Log into CTC , page 2-25
Required/As Needed	As needed
Onsite/Remote	Onsite or remote
Security Level	Retrieve or higher



Note If you modify background colors, the change is stored in your CTC user profile on the computer. The change does not affect other CTC users.

Step 1 From the View menu in CTC, choose **Go to Network View**.

- Step 2** If you want to change a domain background, double-click the domain. If not, continue with [Step 3](#).
 - Step 3** Right-click the network view or domain map area and choose **Set Background Color** from the shortcut menu.
 - Step 4** In the Choose Color dialog box, select a background color.
 - Step 5** Click **OK**.
 - Step 6** Return to your originating procedure (NTP).
-

DLP-G169 Change the Default Network View Background Map

Purpose	This task changes the default map of the CTC network view.
Tools/Equipment	None
Prerequisite Procedures	DLP-G46 Log into CTC, page 2-25
Required/As Needed	As needed
Onsite/Remote	Onsite or remote
Security Level	Superuser



Note If you modify the background image, the change is stored in your CTC user profile on the computer. The change does not affect other CTC users.

- Step 1** From the Edit menu, choose **Preferences > Map** and check the **Use Default Map** check box.
 - Step 2** Click **Apply**.
 - Step 3** Click **OK**. Verify that the United States map is displayed.
 - Step 4** In network view, double-click any node on the map.
 - Step 5** In node view (single-shelf mode) or multishelf view (multishelf mode), click the **Provisioning > Defaults** tabs. Wait for the Defaults selector frame to load the defaults. This could take a few minutes.
 - Step 6** In the Defaults Selector area, choose **CTC** and then **network**. (You might have to scroll down on the list to find “network.”)
 - Step 7** Click the **Default Value** field and choose a default map from the drop-down list. Map choices are Germany, Japan, Netherlands, South Korea, United Kingdom, and the United States.
 - Step 8** Click **Apply**.
 - Step 9** Click **OK**.
 - Step 10** From the View menu, select **Go to Network View**. Confirm that the new map is displayed.
 - Step 11** If the ONS 15454 icons are not visible, right-click the network view and choose **Zoom Out**. Repeat until all the ONS 15454 icons are visible. (You can also choose **Fit Graph to Window**.)
 - Step 12** If you need to reposition the node icons, drag and drop them one at a time to a new location on the map.
 - Step 13** If you want to change the magnification of the icons, right-click the network view and choose **Zoom In**. Repeat until the ONS 15454 icons are displayed at the magnification you want.
 - Step 14** Return to your originating procedure (NTP).
-

DLP-G170 Apply a Custom Network View Background Map

Purpose	This task changes the background image or map of the CTC network view.
Tools/Equipment	None
Prerequisite Procedures	DLP-G46 Log into CTC, page 2-25
Required/As Needed	As needed
Onsite/Remote	Onsite or remote
Security Level	Retrieve or higher



Note

You can replace the network view background image with any JPEG or GIF image that is accessible on a local or network drive. If you apply a custom background image, the change is stored in your CTC user profile on the computer. The change does not affect other CTC users.

-
- Step 1** From the Edit menu, choose **Preferences > Map** and uncheck the **Use Default Map** check box.
 - Step 2** From the View menu, choose **Go to Network View**.
 - Step 3** Right-click the network or domain map and choose **Set Background Image**.
 - Step 4** Click **Browse**. Navigate to the graphic file you want to use as a background.
 - Step 5** Select the file. Click **Open**.
 - Step 6** Click **Apply** and then click **OK**.
 - Step 7** If the ONS 15454 icons are not visible, right-click the network view and choose **Zoom Out**. Repeat this step until all the ONS 15454 icons are visible.
 - Step 8** If you need to reposition the node icons, drag and drop them one at a time to a new location on the map.
 - Step 9** If you want to change the magnification of the icons, right-click the network view and choose **Zoom In**. Repeat until the ONS 15454 icons are displayed at the magnification you want.
 - Step 10** Return to your originating procedure (NTP).
-

DLP-G171 Create Domain Icons

Purpose	This task creates a domain, which is an icon that groups ONS 15454 icons in CTC network view. By default, domains are visible to all CTC sessions that log into the network.
Tools/Equipment	None
Prerequisite Procedures	DLP-G46 Log into CTC, page 2-25
Required/As Needed	As needed
Onsite/Remote	Onsite or remote
Security Level	Superuser



Note

To allow users of any security level to create local domains, that is, domains that are visible on the home CTC session only, superusers can change the CTC.network.LocalDomainCreationAndViewing NE default value to TRUE. A TRUE value means any user can maintain the domain information in his or her

Preferences file, meaning domain changes will not affect other CTC sessions. (The default value is FALSE, meaning domain information affects all CTC sessions and only superusers can create a domain or put a node into a domain.) See the “[NTP-G135 Edit Network Element Defaults](#)” procedure on [page 13-41](#) to change NE default values.

-
- Step 1** From the View menu, choose **Go to Network View**.
- Step 2** Right-click the network map and choose **Create New Domain** from the shortcut menu.
- Step 3** When the domain icon appears on the map, click the map name and type the domain name.
- Step 4** Press **Enter**.
- Step 5** Return to your originating procedure (NTP).
-

DLP-G172 Manage Domain Icons

Purpose	This task manages CTC network view domain icons. By default, domains are visible to all CTC sessions that log into the network.
Tools/Equipment	None
Prerequisite Procedures	DLP-G46 Log into CTC, page 2-25 DLP-G171 Create Domain Icons, page 10-28
Required/As Needed	As needed
Onsite/Remote	Onsite or remote
Security Level	Superuser



Note

To allow users of any security level to create local domains, that is, domains that are visible on the home CTC session only, superusers can change the CTC.network.LocalDomainCreationAndViewing NE default value to TRUE. A TRUE value means any user can maintain the domain information in his or her Preferences file, meaning domain changes will not affect other CTC sessions. (The default value is FALSE, meaning domain information affects all CTC sessions and only superusers can create a domain or put a node into a domain.) See the “[NTP-G135 Edit Network Element Defaults](#)” procedure on [page 13-41](#) to change NE default values.

-
- Step 1** From the View menu, choose **Go to Network View**.
- Step 2** Locate the domain action that you want to perform in [Table 10-2](#) and complete the appropriate steps.

Table 10-2 *Managing Domains*

Domain Action	Steps
Move a domain	Drag and drop the domain icon to the new location.
Rename a domain	Right-click the domain icon and choose Rename Domain from the shortcut menu. Type the new name in the domain name field.
Add a node to a domain	Drag and drop the node icon to the domain icon.

Table 10-2 Managing Domains (continued)

Domain Action	Steps
Move a node from a domain to the network map	Open the domain and right-click a node. Choose Move Node Back to Parent View .
Open a domain	Complete one of the following: <ul style="list-style-type: none"> • Double-click the domain icon. • Right-click the domain and choose Open Domain.
Return to network view	Right-click the domain view area and choose Go to Parent View from the shortcut menu.
Preview domain contents	Right-click the domain icon and choose Show Domain Overview . The domain icon shows a small preview of the nodes in the domain. To turn off the domain overview, right-click the overview and select Show Domain Overview .
Remove domain	Right-click the domain icon and choose Remove Domain . Any nodes in the domain are returned to the network map.

Step 3 Return to your originating procedure (NTP).

DLP-G173 Enable Dialog Box Do-Not-Display Option

Purpose	This task ensures that a user-selected do-not-display dialog box preference is enabled for subsequent sessions or disables the do-not-display option.
Tools/Equipment	None
Prerequisite Procedures	DLP-G46 Log into CTC, page 2-25
Required/As Needed	As needed
Onsite/Remote	Onsite or remote
Security Level	Provisioning or higher



Note

If any user who has rights to perform an operation (for example, creating a circuit) selects the “Do not show this message again” check box in a dialog box, the dialog box is not displayed for any other users who perform that operation on the network from the same computer unless the command is overridden using the following task. (The preference is stored on the computer, not in the node database.)

Step 1 From the Edit menu, choose **Preferences**.

Step 2 In the Preferences dialog box, click the **General** tab.

The Preferences Management area field lists all dialog boxes where “Do not show this message again” is enabled.

Step 3 Choose one of the following options, or uncheck the individual dialog boxes that you want to appear:

- **Don’t Show Any**—Hides all do-not-display check boxes.
- **Show All**—Overrides do-not-display check box selections and displays all dialog boxes.

- Step 4** Click **OK**.
- Step 5** Return to your originating procedure (NTP).

DLP-G174 Switch Between TDM and DWDM Network Views

Purpose	Use this task to switch between time division multiplexing (TDM) and DWDM network views.
Tools/Equipment	None
Prerequisite Procedures	DLP-G46 Log into CTC, page 2-25
Required/As Needed	As needed
Onsite/Remote	Onsite or remote
Security Level	Retrieve or higher

- Step 1** From the View menu, choose **Go to Network View**.
- Step 2** From the Network Scope drop-down list on the toolbar, choose one of the following:
- **All**—Displays both TDM and DWDM nodes.
 - **TDM**—Displays only ONS 15454s with SONET or SDH cards including the transponder (TXP) and muxponder (MSP) cards.
 - **DWDM**—Displays only ONS 15454s with DWDM cards, including the TXP and MXP cards.
- Step 3** Return to your originating procedure (NTP).

DLP-G330 Consolidate Links in Network View

Purpose	This task consolidates DCC, GCC, optical transport service (OTS) and provisionable patchcord (PPC) links in CTC network view.
Tools/Equipment	None
Prerequisite Procedures	DLP-G46 Log into CTC, page 2-25
Required/As Needed	As needed
Onsite/Remote	Onsite or remote
Security Level	Retrieve or higher



Note Global consolidation persists when CTC is re-launched but local consolidation does not persist.

- Step 1** From the View menu, choose **Go to Network View**. CTC shows the link icons by default.
- Step 2** Perform the following steps as needed:
- To toggle between the links, go to [Step 3](#).
 - To consolidate all the links on the network map, go to [Step 4](#).

- To consolidate a link or links between two nodes, go to [Step 5](#).
- To view information about a consolidated link, go to [Step 6](#).
- To access an individual link within a consolidated link, go to [Step 7](#).
- To expand consolidated links, go to [Step 8](#).
- To filter the links by class, go to [Step 9](#).

Step 3 Right-click on the network map and choose **Show Link Icons** to toggle the link icons on and off.

Step 4 To consolidate all the links on the network map (global consolidation):

- Right-click anywhere on the network map.
- Choose **Collapse/Expand Links** from the shortcut menu. The Collapse/Expand Links dialog window appears.
- Select the check boxes for the link classes you want to consolidate.
- Click **OK**. The selected link classes are consolidated throughout the network map.

Step 5 To consolidate a link or links between two nodes (local consolidation):

- Right-click the link on the network map.
- Choose **Collapse Link** from the shortcut menu. The selected link type consolidates to show only one link.



Note The links consolidate by class. For example, if you select a DCC link for consolidation only the DCC links will consolidate, leaving any other link classes expanded.

[Figure 10-2](#) shows the network view with unconsolidated DCC and PPC links.

Figure 10-2 Unconsolidated Links in the Network View

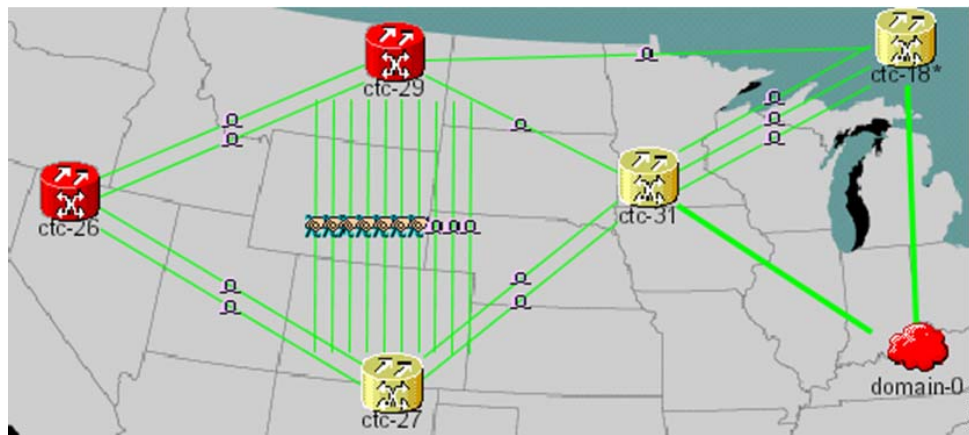

[Figure 10-3](#) shows a network view with globally consolidated links.

Figure 10-3 Consolidated Links in the Network View

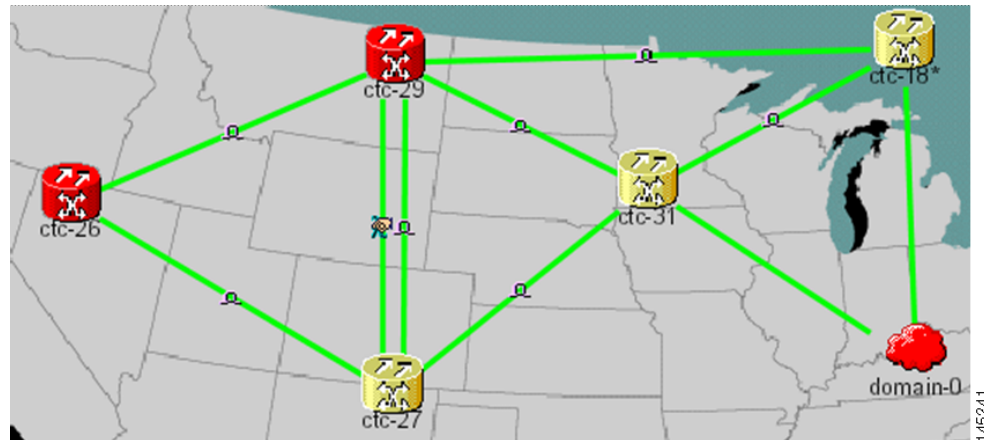

Figure 10-4 shows a network view with local DCC link consolidation between two nodes.

Figure 10-4 Network View with Local Link Consolidation



- Step 6** To view information about a consolidated link, either move your mouse over the link (the tooltip displays the number of links and the link class) or single-click the link to display detailed information on the left side of the window.
- Step 7** To access an individual link within a consolidated link (for example, if you need to perform a span upgrades):
- a. Right-click the consolidated link. A shortcut menu appears with a list of the individual links.
 - b. Hover the mouse over the selected link. A cascading menu appears where you can select an action for the individual link or navigate to one of the nodes where the link is attached.
- Step 8** To expand locally consolidated links, right-click the consolidated link and choose **Expand [link class] Links** from the shortcut menu, where “link class” is DCC, PPC, etc.
- Step 9** To filter the links by class:
- a. Click the **Link Filter** button in the upper right area of the window. The Link Filter dialog appears.

The link classes that appear in the Link Filter dialog are determined by the Network Scope you choose in the network view (Table 10-3).

Table 10-3 Link Classes By Network Scope

Network Scope	Displayed Link Classes
ALL	DCC, GCC, OTS, PPC, Server Trail
DWDM	GCC, OTS, PPC
TDM	DCC, PPC

- b. Check the check boxes next to the links you want to display.
- c. Click **OK**.

Step 10 Return to your originating procedure (NTP).

NTP-G83 Modify or Delete Card Protection Settings

Purpose	This procedure modifies and deletes card protection settings.
Tools/Equipment	None
Prerequisite Procedures	NTP-G33 Create a Y-Cable Protection Group, page 5-14
Required/As Needed	As needed
Onsite/Remote	Onsite or remote
Security Level	Provisioning or higher



Caution

Modifying and deleting protection groups can be service affecting.

Step 1 Complete the “[DLP-G46 Log into CTC](#)” task on page 2-25. If you are already logged in, continue with Step 2.

Step 2 Perform any of the following tasks as needed:

- [DLP-G175 Modify a Y-Cable Protection Group, page 10-35](#)
- [DLP-G176 Modify a Splitter Protection Group, page 10-35](#)
- [DLP-G177 Delete a Y-Cable Protection Group, page 10-36](#)

Step 3 Complete the “[NTP-G103 Back Up the Database](#)” procedure on page 13-2.

Stop. You have completed this procedure.

DLP-G175 Modify a Y-Cable Protection Group

Purpose	This task modifies a Y-cable protection group that has been created for two TXP or MXP card client ports.
Tools/Equipment	None
Prerequisite Procedures	NTP-G33 Create a Y-Cable Protection Group, page 5-14 DLP-G46 Log into CTC, page 2-25
Required/As Needed	As needed
Onsite/Remote	Onsite or remote
Security Level	Provisioning or higher

-
- Step 1** In node view (single-shelf mode) or shelf view (multishelf mode), click the **Provisioning > Protection** tabs.
- Step 2** In the Protection Groups area, click the Y-cable protection group that you want to modify.
- Step 3** Click **Edit**.
- Step 4** In the Selected Group area, you can modify the following, as needed:
- **Name**—Type the changes to the protection group name. The name can have up to 32 alphanumeric characters.
 - **Revertive**—Check this box if you want traffic to revert to the working card after failure conditions stay corrected for the amount of time chosen from the Reversion Time list. Uncheck this box if you do not want traffic to revert.
 - **Reversion time**—If the Revertive check box is selected, choose the reversion time from the Reversion time drop-down list. The range is 0.5 to 12.0 minutes. The default is 5.0 minutes. This is the amount of time that will elapse before the traffic reverts to the working card. Traffic can revert when conditions causing the switch are cleared.
- Step 5** Click **OK**. Confirm that the changes appear.
- Step 6** Return to your originating procedure (NTP).
-

DLP-G176 Modify a Splitter Protection Group

Purpose	This task modifies a splitter protection group for any client port on a TXPP_MR_2.5G or MXPP_MR_2.5G card. Splitter protection is automatically created when the TXPP or MXPP card is installed.
Tools/Equipment	None
Prerequisite Procedures	DLP-G46 Log into CTC, page 2-25
Required/As Needed	As needed
Onsite/Remote	Onsite or remote
Security Level	Provisioning or higher

-
- Step 1** In node view (single-shelf mode) or shelf view (multishelf mode), click the **Provisioning > Protection** tabs.
- Step 2** In the Protection Groups area, click the splitter protection group that you want to modify.
- Step 3** Click **Edit**.
- Step 4** In the Selected Group area, you can modify the following, as needed:
- **Name**—Type the changes to the protection group name. The name can have up to 32 alphanumeric characters.
 - **Revertive**—Check this box if you want traffic to revert to the working card after failure conditions stay corrected for the amount of time chosen from the Reversion Time list. Uncheck this box if you do not want traffic to revert.
 - **Reversion time**—If the Revertive check box is selected, choose the reversion time from the Reversion time drop-down list. The range is 0.5 to 12.0 minutes. The default is 5.0 minutes. This is the amount of time that will elapse before the traffic reverts to the working card. Traffic can revert when conditions causing the switch are cleared.
- Step 5** Click **OK**. Confirm that the changes appear.
- Step 6** Return to your originating procedure (NTP).
-

DLP-G177 Delete a Y-Cable Protection Group

Purpose	This task deletes a Y-cable protection group.
Tools/Equipment	None
Prerequisite Procedures	DLP-G46 Log into CTC, page 2-25
Required/As Needed	As needed
Onsite/Remote	Onsite or remote
Security Level	Provisioning or higher

-
- Step 1** In node view (single-shelf mode) or shelf view (multishelf mode), double-click the Near End Transponder Card to open it in the card view.
- Step 2** In the card view mode, click the **Provisioning** tab. The Line tab view with the ports provisioned is displayed.
- Step 3** Click the **Admin State** list box and select the **Out-of-Service (OOS)** option for the Near End Transponder Trunk and Client Ports (example:1-1(OC3), 2(OC48)).
- Step 4** Click **Apply**. Repeat steps 1-4 for the Far End Transponder Card.
- Step 5** Right-click the **Tranponder card** in card view mode and select **Go to Parent View**.
- Step 6** In node view (single-shelf mode) or shelf view (multishelf mode), click the **Provisioning->Protection** tabs.
- Step 7** In the Protection Groups area, disconnect the Y-Cable fiber for the Protection Transponder ports in the protection group you want to delete.
- Step 8** Select the protection group and click **Delete**.
- Step 9** Click **Yes** in the Delete Protection Group dialog box. Confirm that the changes appear.

Step 10 Return to your originating procedure (NTP).



Note

When you delete the protection group, traffic drops because both the Transponder TX ports will be in a Service state (Protect TX port gets turned on). The Transponder TX ports are connected through a Y-cable and as a result two signals will be passing through the same fiber. Hence, you should put the protect port OOS and remove the fibering for the protect port and then delete the protection group.

NTP-G84 Initiate and Clear Y-Cable and Splitter External Switching Commands

Purpose	This procedure describes how to apply and remove Manual and Force protection switches on Y-cable and splitter protection groups. It also describes how to apply and remove a Lock On or Lock Out protection command to a Y-cable protection group.
Tools/Equipment	None
Prerequisite Procedures	NTP-G32 Install the Transponder and Muxponder Cards, page 3-50 NTP-G33 Create a Y-Cable Protection Group, page 5-14
Required/As Needed	As needed
Onsite/Remote	Onsite
Security Level	Superuser



Note

Splitter protection groups are automatically created when you install a TXPP_MR_2.5G or MXPP_MR_2.5G card.

- Step 1** Complete the “[DLP-G46 Log into CTC](#)” task on page 2-25. If you are already logged in, continue with Step 2.
- Step 2** To perform a Manual protection switch, complete the “[DLP-G178 Apply a Manual Y-Cable or Splitter Protection Switch](#)” task on page 10-38.
- Step 3** To perform a Force protection switch, complete the “[DLP-G179 Apply a Force Y-Cable or Splitter Protection Switch](#)” task on page 10-38.
- Step 4** To clear a Force or Manual protection switch, complete the “[DLP-G180 Clear a Manual or Force Y-Cable or Splitter Protection Switch](#)” task on page 10-39.
- Step 5** To prevent traffic on a working or protect card from switching to the other card in the pair, complete the “[DLP-G181 Apply a Lock-On](#)” task on page 10-40.
- Step 6** To prevent traffic from switching to the protect card, complete the “[DLP-G182 Apply a Lockout](#)” task on page 10-40.
- Step 7** To remove a lock-on or lockout and return a protection group to its usual switching method, complete the “[DLP-G183 Clear a Lock-On or Lockout](#)” task on page 10-41.

Stop. You have completed this procedure.

DLP-G178 Apply a Manual Y-Cable or Splitter Protection Switch

Purpose	This task performs a Manual protection switch on a Y-cable or splitter protection group.
Tools/Equipment	None
Prerequisite Procedures	DLP-G46 Log into CTC, page 2-25
Required/As Needed	As needed
Onsite/Remote	Onsite or remote
Security Level	Maintenance or higher



Caution

A Manual switch will move traffic from the active to the standby card only if network conditions permit it. If conditions change during the switch, CTC will attempt to place traffic back on the original active card.

-
- Step 1** In node view (single-shelf mode) or shelf view (multishelf mode), click the **Maintenance > Protection** tabs.
- Step 2** In the Protection Groups list, click the Y-cable or splitter protection group where you want to apply the Manual protection switch.
- Step 3** In the Selected Group area, click the active card or port.
- Step 4** In the Switch Commands drop-down list, click **Manual**.
- Step 5** In the Confirm Manual Operation dialog box, click **Yes**.
- If conditions permit, the Manual switch will be applied. To clear the Manual switch, see the “[DLP-G180 Clear a Manual or Force Y-Cable or Splitter Protection Switch](#)” task on page 10-39.
- Step 6** Return to your originating procedure (NTP).
-

DLP-G179 Apply a Force Y-Cable or Splitter Protection Switch

Purpose	This task performs a Force protection switch on a Y-cable or splitter protection group.
Tools/Equipment	None
Prerequisite Procedures	DLP-G46 Log into CTC, page 2-25
Required/As Needed	As needed
Onsite/Remote	Onsite or remote
Security Level	Maintenance or higher



Caution

A Force switch will move traffic from the active to the standby card or port immediately, regardless of network conditions. The switch will remain in effect until it is cleared.

-
- Step 1** In node view (single-shelf mode) or shelf view (multishelf mode), click the **Maintenance > Protection** tabs.

- Step 2** In the Protection Groups list, click the Y-cable or splitter protection group where you want to apply the Force protection switch.
- Step 3** In the Selected Group area, click the active card or port.
- Step 4** In the Switch Commands drop-down list, click **Force**.
- Step 5** In the Confirm Manual Operation dialog box, click **Yes**.
- The Force switch will be applied. To clear the Force switch, see the “[DLP-G180 Clear a Manual or Force Y-Cable or Splitter Protection Switch](#)” task on page 10-39.
- Step 6** Return to your originating procedure (NTP).
-

DLP-G180 Clear a Manual or Force Y-Cable or Splitter Protection Switch

Purpose	This task clears a Manual or Force protection switch on a Y-cable or splitter protection group.
Tools/Equipment	None
Prerequisite Procedures	<p>DLP-G46 Log into CTC, page 2-25</p> <p>One of the following tasks:</p> <ul style="list-style-type: none"> • DLP-G178 Apply a Manual Y-Cable or Splitter Protection Switch, page 10-38 • DLP-G179 Apply a Force Y-Cable or Splitter Protection Switch, page 10-38
Required/As Needed	As needed
Onsite/Remote	Both
Security Level	Maintenance or higher

- Step 1** In node view (single-shelf mode) or shelf view (multishelf mode), click the **Maintenance > Protection** tabs.
- Step 2** In the Protection Groups area, click the protection group that contains the card you want to clear.
- Step 3** In the Selected Group area, click the card that you want to clear.
- Step 4** In the Switch Commands drop-down list, click **Clear**.
- Step 5** Click **Yes** in the confirmation dialog box.
- The Manual or Force protection switch is cleared.
- Step 6** Return to your originating procedure (NTP).
-

DLP-G181 Apply a Lock-On

Purpose	This task prevents traffic from being switched from the working/active card in a Y-cable protection group or port in a splitter protection group.
Tools/Equipment	None
Prerequisite Procedures	DLP-G46 Log into CTC, page 2-25
Required/As Needed	As needed
Onsite/Remote	Onsite or remote
Security Level	Maintenance or higher

Note

You can apply the Lock On command only to the working/active card or port. If the working card or port is standby (traffic is switched), the Lock On button is not available.

-
- Step 1** In node view (single-shelf mode) or shelf view (multishelf mode), click the **Maintenance > Protection** tabs.
- Step 2** In the Protection Groups area, click the protection group that contains the card (Y-cable) or port (splitter) that you want to lock on.
- Step 3** In the Selected Group area, click the working/active card.
- Step 4** In the Inhibit Switching drop-down list, click **Lock On**.
- Step 5** Click **Yes** in the confirmation dialog box.

The lock-on has been applied. Traffic cannot switch to the protect card. To clear the lock-on, see the “[DLP-G183 Clear a Lock-On or Lockout](#)” task on page 10-41.

Note

Provisioning a lock-on raises a LOCKON-REQ or an FE-LOCKON condition in CTC. Clearing the lock-on switch request clears these conditions.

- Step 6** Return to your originating procedure (NTP).
-

DLP-G182 Apply a Lockout

Purpose	This task keeps traffic from switching to the protect/standby card or port. The Lock Out command overrides the Force and Manual switching commands.
Tools/Equipment	None
Prerequisite Procedures	DLP-G46 Log into CTC, page 2-25
Required/As Needed	As needed
Onsite/Remote	Onsite or remote
Security Level	Maintenance or higher



Note You can apply the lockout to the protect/standby card or port. If the protect card or port is active (traffic is switched), the lockout task cannot be performed.

- Step 1** In node view (single-shelf mode) or shelf view (multishelf mode), click the **Maintenance > Protection** tabs.
- Step 2** In the Protection Groups area, click the protection group that contains the card (Y-cable) or port (splitter) that you want to lock out.
- Step 3** In the Selected Group area, click the protect/standby card.
- Step 4** In the Inhibit Switching drop-down list, click **Lock Out**.
- Step 5** Click **Yes** in the confirmation dialog box.

The lockout has been applied. Traffic cannot switch to the protect card. To clear the lockout, see the “[DLP-G183 Clear a Lock-On or Lockout](#)” task on page 10-41.



Note Provisioning a lockout raises a LOCKOUT-REQ or an FE-LOCKOUT condition in CTC. Clearing the lockout switch request clears these conditions.

- Step 6** Return to your originating procedure (NTP).

DLP-G183 Clear a Lock-On or Lockout

Purpose	This task clears a lock-on or lockout.
Tools/Equipment	None
Prerequisite Procedures	DLP-G46 Log into CTC, page 2-25 One of the following tasks: <ul style="list-style-type: none"> • DLP-G181 Apply a Lock-On, page 10-40 • DLP-G182 Apply a Lockout, page 10-40
Required/As Needed	As needed
Onsite/Remote	Both
Security Level	Maintenance or higher

- Step 1** In node view (single-shelf mode) or shelf view (multishelf mode), click the **Maintenance > Protection** tabs.
- Step 2** In the Protection Groups area, click the protection group that contains the card you want to clear.
- Step 3** In the Selected Group area, click the card you want to clear.
- Step 4** In the Inhibit Switching drop-down list, click **Unlock**.
- Step 5** Click **Yes** in the confirmation dialog box.
- The lock-on or lockout is cleared.

Step 6 Return to your originating procedure (NTP).

NTP-G85 Modify or Delete OSC Terminations, DCC/GCC Terminations, and Provisionable Patchcords

Purpose	This procedure modifies DCC/GCC terminations, and deletes provisionable patchcords, OSC terminations, and GCC terminations.
Tools/Equipment	None
Prerequisite Procedures	One or more of the following tasks: <ul style="list-style-type: none"> • DLP-G76 Provision DCC/GCC Terminations, page 7-22 • NTP-G38 Provision OSC Terminations, page 3-83 • DLP-G99 Create a Provisionable Patchcord, page 7-20
Required/As Needed	As needed
Onsite/Remote	Onsite or remote
Security Level	Provisioning or higher



Caution

Deleting an OSC termination can cause you to lose visibility of nodes that do not have other OSCs or network connections to the CTC computer.

Step 1 Complete the “[DLP-G46 Log into CTC](#)” task on page 2-25. If you are already logged in, continue with Step 2.

Step 2 In node view (single-shelf mode) or multishelf view (multishelf mode), complete the following tasks as needed:

- To modify a GCC termination, complete the “[DLP-G184 Change a DCC/GCC Termination](#)” task on page 10-43.
- To delete a GCC termination, complete the “[DLP-G185 Delete a DCC/GCC Termination](#)” task on page 10-43.
- To delete an OSC termination, complete the “[DLP-G186 Delete an OSC Termination](#)” task on page 10-44.
- To delete a provisionable patchcord, complete the “[DLP-G187 Delete a Provisionable Patchcord](#)” task on page 10-45.

Stop. You have completed this procedure.

DLP-G184 Change a DCC/GCC Termination

Purpose	This task modifies a DCC/GCC termination. You can enable or disable OSPF and enable or disable the foreign node setting.
Tools/Equipment	None
Prerequisite Procedures	DLP-G46 Log into CTC, page 2-25
Required/As Needed	As needed
Onsite/Remote	Remote
Security Level	Provisioning or higher

-
- Step 1** In node view (single-shelf mode) or shelf view (multishelf mode), click the **Provisioning > Comm Channels**.
- Step 2** Select the DCC or GCC tabs as necessary. Available tabs are:
- GCC (both ANSI and ETSI)
 - DCC
 - SDCC and LDCC (for ANSI)
 - RS-DCC and MS-DCC (for ETSI)
- Step 3** Select the DCC/GCC that you want to change.
- Step 4** Click **Edit**. The Edit Termination dialog box appears.
- Step 5** Complete the following as necessary:
- GCC Rate—(Display only) Indicates the communication channel rate.
 - Disable OSPF on Link—If checked, OSPF is disabled on the link. OSPF should be disabled only when the slot and port connect to third-party equipment that does not support OSPF.
 - Far End is Foreign—Check this box to specify that the DCC/GCC termination is a non-ONS node.
 - Far end IP—If you checked the Far End is Foreign check box, type the IP address of the far-end node or leave the 0.0.0.0 default. An IP address of 0.0.0.0 means that any address can be used by the far end.
- Step 6** Click **OK**.
- Step 7** Return to your origination procedure (NTP).
-

DLP-G185 Delete a DCC/GCC Termination

Purpose	This task deletes the DWDM DCC/GCC terminations required for network setup when using TXP or MXP cards.
Tools/Equipment	None
Prerequisite Procedures	DLP-G46 Log into CTC, page 2-25
Required/As Needed	As needed
Onsite/Remote	Onsite or remote
Security Level	Provisioning or higher

**Note**

Deleting the DCC/GCC termination on a port also deletes any provisionable patchcord links that might exist on the port.

-
- Step 1** In node view (single-shelf mode) or shelf view (multishelf mode), click the **Provisioning > Comm Channel**.
- Step 2** Select the DCC or GCC tabs as necessary. Available tabs are:
- GCC (both ANSI and ETSI)
 - DCC
 - SDCC and LDCC (for ANSI)
 - RS-DCC and MS-DCC (for ETSI)
- Step 3** Select the DCC/GCC that you want to delete.
- Step 4** Click **Delete**.
- Step 5** In the Delete Terminations dialog box, check the **Set port OOS** check box if you want to place ports out of service.
- Step 6** Click **Yes**. The following alarms will appear until all network terminations are deleted and the ports are out of service:
- GCC-EOC for GCC termination
 - EOC for SDCC termination
 - EOC-L for LDCC termination
- Step 7** Return to your originating procedure (NTP).
-

DLP-G186 Delete an OSC Termination

Purpose	This task deletes an OSC termination on the ONS 15454.
Tools/Equipment	None
Prerequisite Procedures	DLP-G46 Log into CTC, page 2-25
Required/As Needed	As needed
Onsite/Remote	Onsite or remote
Security Level	Provisioning or higher

**Caution**

Deleting a OSC termination might cause node isolation and loss of visibility to nodes that do not have other OSCs or network connections to the CTC computer.

-
- Step 1** Click the **Provisioning > Comm Channel > OSC** tabs.
- Step 2** If a Ring ID is created, complete the following steps. Otherwise, continue with [Step 3](#).
- a. Select the DWDM Ring ID that you want to delete and click **Delete**.
 - b. In the Delete DWDM Ring ID confirmation box, click **Yes**. Confirm that the changes appear.

- Step 3** Click the OSC termination that you want to delete and click **Delete**.
- Step 4** In the Delete OSC Termination confirmation box, click **Yes**. Confirm that the changes appear.
Until all network OSC terminations are deleted, loss of signal (LOS) or power failure alarms might appear on the OPT-BST amplifier, OSCM card, and OSC-CSM card.
- Step 5** Return to your originating procedure (NTP).

DLP-G187 Delete a Provisionable Patchcord

Purpose	This task deletes a provisionable patchcord.
Tools/Equipment	None
Prerequisite Procedures	DLP-G46 Log into CTC, page 2-25 DLP-G99 Create a Provisionable Patchcord, page 7-20
Required/As Needed	As needed
Onsite/Remote	Onsite or remote
Security Level	Provisioning and higher

- Step 1** In node view (single-shelf mode) or multishelf view (multishelf mode), click the **Provisioning > Comm Channels > PPC** tabs. If you are in network view, click **Provisioning > Provisionable Patchcords** tabs.
- Step 2** Click the provisionable patchcord that you want to delete.
- Step 3** Click **Delete**.
- Step 4** In the confirmation dialog box, click **Yes**.
- Step 5** Return to your originating procedure (NTP).

NTP-G86 Convert a Pass-Through Connection to Add/Drop Connections

Purpose	This procedure converts a pass-through connection into add/drop connections (one on the add side and the other on the drop side). Use this procedure during a network upgrade. Pass-through channel connections can be provided between channel input and output ports for the AD-xC-xx.x, 4MD-xx.x, 32MUX-O, 32DMX-O, 32DMX, and 32DMX-L cards. You can set up pass-through connections in nodes that might require more add or drop channel capability or configuration.
Tools/Equipment	None
Prerequisite Procedures	None
Required/As Needed	As needed

Onsite/Remote	Onsite
Security Level	Provisioning or higher

-
- Step 1** Complete the “[DLP-G46 Log into CTC](#)” task on page 2-25 at an ONS 15454 on the network.
- Step 2** In node view (single-shelf mode) or multishelf view (multishelf mode), click the **Circuits** tab. Delete the unidirectional or bidirectional pass-through optical channel network connection (OCHNC) that applies to the pass-through connection to be removed.
- Step 3** Remove the physical pass-through cabling. Click the **Provisioning > WDM-ANS > Internal Patchcords** tabs to identify the card ports to be removed. The pass-through connection that you are removing can be connected in both OADM and hub nodes.
- For a hub node—Connect the 32DMX-O, 32DMX, or 32DMX-L output port to the 32MUX-O input port.
 - For an OADM node—Connect the AD-xC-xx.x drop (TX) port to the AD-xC-xx.x add (RX) port.
- Step 4** Physically connect the proper client interface to the correct add and drop ports.
- Step 5** Delete the filter connections related to the pass-through connection that is being converted to an add/drop connection:
- a. In node view (single-shelf mode) or multishelf view (multishelf mode), click the **Provisioning > WDM-ANS > Port Status** tabs.
 - b. Highlight the pass-through connections between ITU-T channel add and drop port filters.
 - c. Click **Delete**.
- Step 6** Create two new unidirectional OCHNCs (one heading east, the other heading west) to support the new add/drop channels. See the “[DLP-G105 Provision Optical Channel Network Connections](#)” task on page 7-11.
- Step 7** As necessary, complete the [DLP-G99 Create a Provisionable Patchcord](#), page 7-20.
- Step 8** As necessary, add an optical attenuator between the channel TX port of the AD-xC-xx.x, 4MD-xx.x, 32DMX-O, 32DMX, or 32-DMX-L card and the DWDM RX port on the TXP, MXP, or OC-N/STM-N ITU-T line card.



Note If the channel is coming from a 32DMX-O, the optical power can be adjusted in CTC by modifying the value of the internal per-channel variable optical attenuator (VOA).

- Step 9** (Optional) The following verification steps might be needed for an intermediate node when a pass-through connection is converted:
- a. Verify that the received channels are at the specified power level. See the “[NTP-G76 Verify Optical Span Loss Using CTC](#)” procedure on page 10-2 for instructions.
 - b. Verify that the added channels are equalized with the express channels within +/-1 dB.
 - c. If the channels are not equalized with the express channels within +/-1 dB, check the attenuation of the VOAs.
 - d. Check all the fiber adapters to minimize their insertion losses. See the “[NTP-G115 Clean Fiber Connectors](#)” procedure on page 13-25 for instructions.

Stop. You have completed this procedure.

NTP-G87 Change Node Timing Parameters

Purpose	This procedure changes the timing parameters for the ONS 15454. To switch the timing reference, see the “NTP-G112 Change the Node Timing Reference” procedure on page 13-17 .
Tools/Equipment	None
Prerequisite Procedures	NTP-G53 Set Up Timing, page 6-4
Required/As Needed	As needed
Onsite/Remote	Onsite or remote
Security Level	Provisioning or higher



Caution

The following procedure might be service affecting and should be performed during a scheduled maintenance window.

- Step 1** Complete the [“DLP-G46 Log into CTC” task on page 2-25](#). If you are already logged in, continue with Step 2.
- Step 2** Complete the [“NTP-G103 Back Up the Database” procedure on page 13-2](#).
- Step 3** Click the **Provisioning > Timing > General** tabs.
- Step 4** In the General Timing section, change any of the following information:

- Timing Mode



Note Because mixed timing can cause timing loops, Cisco does not recommend using the Mixed Timing option. Use this mode with care.

- SSM Message Set
- Quality of RES
- Revertive
- Revertive Time

See the [“NTP-G53 Set Up Timing” task on page 6-4](#) for field descriptions.

- Step 5** In the Reference Lists area, you can change the following information:



Note Reference lists define up to three timing references for the node and up to six BITS Out references. BITS Out references define the timing references used by equipment that can be attached to the node’s BITS Out pins on the backplane. If you attach equipment to BITS Out pins, you normally attach it to a node with Line mode because equipment near the external timing reference can be directly wired to the reference.

- NE Reference
- BITS 1 Out
- BITS 2 Out

- Step 6** Click the **Provisioning > Timing > BITS Facilities** tabs.

Step 7 In the BITS In section, you can change the following information:



Note The BITS Facilities section sets the parameters for your BITS1 and BITS2 timing references. Many of these settings are determined by the timing source manufacturer. If equipment is timed through BITS Out, you can set timing parameters to meet the requirements of the equipment.

- BITS In State
- Coding
- State
- Framing
- Sync Messaging
- Admin SSM

Step 8 In the BITS Out section, you can change the following information:

- Coding
- Framing
- AIS Threshold
- LBO

Step 9 Click **Apply**. Confirm that the changes appear.



Caution Internal timing is Stratum 3 and is not intended for permanent use. All ONS 15454s should be timed to a Stratum 2 or better primary reference source.

Step 10 Complete the [“NTP-G103 Back Up the Database” procedure on page 13-2](#).

Stop. You have completed this procedure.

NTP-G88 Modify Users and Change Security

Purpose	This procedure modifies user and security properties for the ONS 15454.
Tools/Equipment	None
Prerequisite Procedures	NTP-G23 Create Users and Assign Security, page 3-7
Required/As Needed	As needed
Onsite/Remote	Onsite or remote
Security Level	Superuser

Step 1 Complete the [“DLP-G46 Log into CTC” task on page 2-25](#). If you are already logged in, continue with Step 2.

Step 2 Complete the [“NTP-G103 Back Up the Database” procedure on page 13-2](#).

Step 3 Perform any of the following tasks as needed:

- [DLP-G188 Change Security Policy for a Single Node, page 10-49](#)
 - [DLP-G189 Change Security Policy for Multiple Nodes, page 10-50](#)
 - [DLP-G317 Change Node Access and PM Clearing Privilege, page 10-52](#)
 - [DLP-G328 Grant Superuser Privileges to a Provisioning User, page 10-53](#)
 - [DLP-G191 Change User Password and Security Level on a Single Node, page 10-54](#)
 - [DLP-G192 Change User Password and Security Level for Multiple Nodes, page 10-55](#)
 - [DLP-G193 Delete a User From a Single Node, page 10-55](#)
 - [DLP-G194 Delete a User From Multiple Nodes, page 10-56](#)
 - [DLP-G195 Log Out a User on a Single Node, page 10-57](#)
 - [DLP-G196 Log Out a User on Multiple Nodes, page 10-58](#)
 - [DLP-G281 Configure the Node for RADIUS Authentication, page 10-58](#)
 - [DLP-G282 View and Terminate Active Logins, page 10-61](#)
- Step 4** Complete the “[NTP-G103 Back Up the Database](#)” procedure on page 13-2.
- Stop. You have completed this procedure.**
-

DLP-G188 Change Security Policy for a Single Node

Purpose	This task changes the security policy for a single node, including idle user timeouts, user lockouts, password changes, and concurrent login policies.
Tools/Equipment	None
Prerequisite Procedures	DLP-G46 Log into CTC, page 2-25
Required/As Needed	As needed
Onsite/Remote	Onsite or remote
Security Level	Superuser

- Step 1** In node view (single-shelf mode) or multishelf view (multishelf mode), click the **Provisioning > Security > Policy** tabs.
- Step 2** If you want to modify the idle user timeout period, click the hour (H) and minute (M) arrows in the Idle User Timeout area for the security level that you want to provision: RETRIEVE, MAINTENANCE, PROVISIONING, or SUPERUSER. The idle period time range is 0 and 16 hours, and 0 and 59 minutes. The user is logged out after the idle user timeout period is reached.
- Step 3** In the User Lockout area, you can modify the following:
- **Failed Logins Before Lockout**—The number of failed login attempts a user can make before the user is locked out from the node. You can choose a value between 0 and 10.
 - **Manual Unlock by Superuser**—Allows a user with Superuser privileges to manually unlock a user who has been locked out from a node.
 - **Lockout Duration**—Sets the amount of time the user will be locked out after a failed login. You can choose a value between 0 and 10 minutes, and 0 and 55 seconds (in five-second intervals).



Note Manual Unlock by Superuser and Lockout Duration are mutually exclusive.

- Step 4** In the Password Change area, you can modify the following:
- Prevent Reusing Last [] Passwords—Choose a value between 1 and 10 to set the number of different passwords that the user must create before they can reuse a password.
 - New Password must Differ from the Old Password—Choose the number of characters that must differ between the old and new password. The default number is 1. The range is 1 to 5.
 - Cannot Change New Password for [] days—If checked, prevents users from changing their password for the specified period. The range is 20 to 95 days.
 - Require Password Change on First Login to New Account—If checked, requires users to change their password the first time they log into their account.
- Step 5** To require users to change their password at periodic intervals, check the Enforce Password Aging check box in the Password Aging area. If checked, provision the following parameters:
- Aging Period—Sets the amount of time that must pass before the user must change his or her password for each security level: RETRIEVE, MAINTENANCE, PROVISIONING, and SUPERUSER. The range is 20 to 95 days.
 - Warning Period—Sets the number days the user will be warned to change his or her password for each security level. The range is 2 to 20 days.
- Step 6** In the Other area, you can provision the following:
- Single Session Per User—If checked, limits users to one login session at one time.
 - Disable Inactive User—If checked, disables users who do not log into the node for the period of time specified in the Inactive Duration box. The Inactive Duration range is 1 to 99 days.
- Step 7** Click **Apply**. Confirm that the changes appear.
- Step 8** Return to your originating procedure (NTP).
-

DLP-G189 Change Security Policy for Multiple Nodes

Purpose	This task changes the security policy for multiple nodes including idle user timeouts, user lockouts, password change, and concurrent login policies.
Tools/Equipment	None
Prerequisite Procedures	DLP-G46 Log into CTC, page 2-25
Required/As Needed	As needed
Onsite/Remote	Onsite or remote
Security Level	Superuser

- Step 1** From the View menu, choose **Go to Network View**.
- Step 2** Click the **Provisioning > Security > Policy** tabs. A read-only table of nodes and their policies appears.
- Step 3** Click a node on the table that you want to modify, then click **Change**.

Step 4 If you want to modify the idle user timeout period, click the hour (H) and minute (M) arrows in the Idle User Timeout area for the security level that you want to provision: RETRIEVE, MAINTENANCE, PROVISIONING, or SUPERUSER. The idle period time range is 0 and 16 hours, and 0 and 59 minutes. The user is logged out after the idle user timeout period is reached.

Step 5 In the User Lockout area, you can modify the following:

- Failed Logins Before Lockout—The number of failed login attempts a user can make before the user is locked out from the node. You can choose a value between 0 and 10.
- Manual Unlock by Superuser—Allows a user with Superuser privileges to manually unlock a user who has been locked out from a node.
- Lockout Duration—Sets the amount of time the user will be locked out after a failed login. You can choose a value between 0 and 10 minutes, and 0 and 55 seconds (in five-second intervals).



Note Manual Unlock by Superuser and Lockout Duration are mutually exclusive.

Step 6 In the Password Change area, you can modify the following:

- Prevent Reusing Last [] Passwords—Choose a value between 1 and 10 to set the number of different passwords that the user must create before they can reuse a password.
- New Password must Differ from the Old Password—Choose the number of characters that must differ between the old and new password. The default number is 1. The range is 1 to 5.
- Cannot Change New Password for [] days—If checked, prevents users from changing their password for the specified period. The range is 20 to 95 days.
- Require Password Change on First Login to New Account—If checked, requires users to change their password the first time they log into their account.

Step 7 To require users to change their password at periodic intervals, check the Enforce Password Aging check box in the Password Aging area. If checked, provision the following parameters:

- Aging Period—Sets the amount of time that must pass before the user must change his or her password for each security level: RETRIEVE, MAINTENANCE, PROVISIONING, and SUPERUSER. The range is 20 to 95 days.
- Warning Period—Sets the number days the user will be warned to change his or her password for each security level. The range is 2 to 20 days.

Step 8 In the Other area, you can provision the following:

- Single Session Per User—If checked, limits users to one login session at one time.
- Disable Inactive User—If checked, disables users who do not log into the node for the period of time specified in the Inactive Duration box. The Inactive Duration range is 1 to 99 days.

Step 9 In the Select Applicable Nodes area, uncheck any nodes where you do not want to apply the changes.

Step 10 Click **OK**.

Step 11 In the Security Policy Change Results dialog box, confirm that the changes are correct, then click **OK**.

Step 12 Return to your originating procedure (NTP).

DLP-G317 Change Node Access and PM Clearing Privilege

Purpose	This task provisions the physical access points and shell programs used to connect to the ONS 15454 and sets the user security level that can clear node performance monitoring (PM) data.
Tools/Equipment	None
Prerequisite Procedures	DLP-G46 Log into CTC, page 2-25
Required/As Needed	As needed
Onsite/Remote	Onsite or remote
Security Level	Superuser

-
- Step 1** In node view (single-shelf mode) or multishelf view (multishelf mode), click the **Provisioning > Security > Access** tabs.
- Step 2** In the Access area, provision the following:
- LAN access—Choose one of the following options to set the access paths to the node:
 - **No LAN Access**—Allows access to the node only through DCC connections. Access through the TCC2/TCC2P RJ-45 port and backplane is not permitted.
 - **Front only**—Allows access through the TCC2/TCC2P RJ-45 port. Access through the DCC and the backplane is not permitted.
 - **Backplane only**—Allows access through DCC connections and the backplane. Access through the TCC2/TCC2P RJ-45 port is not allowed.
 - **Front and Backplane**—Allows access through DCC, TCC2/TCC2P RJ-45 port, and backplane connections.
 - Restore Timeout—Sets a time delay for enabling of front and backplane access when DCC connections are lost and “DCC only” is chosen in LAN Access. Front and backplane access is enabled after the restore timeout period has passed. Front and backplane access is disabled as soon as DCC connections are restored.
- Step 3** In the Shell Access area, set the shell program used to access the node:
- Access State—Allows you to set the shell program access mode to Disable (disables shell access), Non-Secure, or Secure. Secure mode allows access to the node using the Secure Shell (SSH) program. SSH is a terminal-remote host Internet protocol that uses encrypted links.
 - Telnet Port—Allows access to the node using the Telnet port. Telnet is the terminal-remote host Internet protocol developed for the Advanced Agency Research Project Network (ARPANET). Port 23 is the default.
 - Enable Shell Password—If checked, enables the SSH password. To enable the shell password, check the box and click **Apply**. To disable the password, uncheck the check box, click **Apply**, type the current password in the Disable Shell Password dialog box, then click **OK**.
- Step 4** In the TL1 Access area, select the desired level of TL1 access. Disabled completely disables all TL1 access; Non-Secure and Secure allow access using SSH.
- Step 5** In the PM Clearing Privilege field, choose the minimum security level that can clear node PM data: PROVISIONING or SUPERUSER.
- Step 6** Select the Enable Craft Port check box to turn on the shelf controller serial ports.
- Step 7** Select the EMS access state from the list. Available states are Non-Secure and Secure (allows access using SSH).

- Step 8** In the TCC CORBA (IIOP/SSLIOP) Listener Port area, choose a listener port option:
- **Default - TCC Fixed**—Uses Port 57790 to connect to ONS 15454s on the same side of the firewall or if no firewall is used (default). This option can be used for access through a firewall if Port 57790 is open.
 - **Standard Constant**—Uses Port 683 (IIOP) or Port 684 (SSLIOP), the CORBA default port number.
 - **Other Constant**—If the default port is not used, type the IIOP or SSLIOP (Secure Socket Layer Inter-ORB Protocol) port specified by your firewall administrator.
- Step 9** In the SNMP Access area, set the Simple Network Management Protocol (SNMP) access state to Non-Secure or Disabled (disables SNMP access).
- Step 10** Click **Apply**.
- Step 11** Return to your originating procedure (NTP).
-

DLP-G328 Grant Superuser Privileges to a Provisioning User

Purpose	This task enables a provisioning user to retrieve audit logs, restore databases, clear PMs, and activate and revert software loads.
Tools/Equipment	None
Prerequisite Procedures	DLP-G46 Log into CTC, page 2-25
Required/As Needed	As needed
Onsite/Remote	Onsite or remote
Security Level	Superuser

- Step 1** In node view (single-shelf mode) or multishelf view (multishelf mode), click the **Provisioning > Defaults** tabs.
- Step 2** In the Defaults Selector area, choose **NODE**.
- Step 3** In the Default Name area, choose one of the following parameters:
- NODE.security.grantPermission.RetrieveAuditLog
 - NODE.security.grantPermission.RestoreDB
 - NODE.security.grantPermission.PMClearingPrivilege
 - NODE.security.grantPermission.ActivateRevertSoftware
- Step 4** Click the Default Value column and choose **Provisioning** from the drop-down list for each property in [Step 3](#) that you want to change.



Note If you click **Reset** before you click **Apply**, all values will return to their original settings.

- Step 5** Click **Apply**.
- A pencil icon will appear next to the default name that will be changed as a result of editing the defaults file.

Step 6 Return to your originating procedure (NTP).

DLP-G191 Change User Password and Security Level on a Single Node

Purpose	This task changes settings for an existing user at one node.
Tools/Equipment	None
Prerequisite Procedures	DLP-G46 Log into CTC, page 2-25
Required/As Needed	As needed
Onsite/Remote	Onsite or remote
Security Level	Superuser



Note Each ONS 15454 must have one user with a Superuser security level. The default CISCO15 user name and security level cannot be changed unless you create another user with Superuser security.

Step 1 In node view (single-shelf mode) or multishelf view (multishelf mode), click the **Provisioning > Security > Users** tabs.

Step 2 Click the user whose settings you want to modify, then click **Edit**.

Step 3 In the Change User dialog box, you can:

- Change a user password.
- Modify the user security level.
- Lock out the user.
- Disable the user.
- Force the user to change password on next login.

See the “[DLP-G54 Create a New User on a Single Node](#)” procedure on page 3-8 for field descriptions.

Step 4 Click **OK**.

Step 5 Click **OK** in the confirmation dialog box.



Note User settings that you changed during this task will not appear until that user logs off and logs back in.

Step 6 Return to your originating procedure (NTP).

DLP-G192 Change User Password and Security Level for Multiple Nodes

Purpose	This task changes settings for an existing user at multiple nodes.
Tools/Equipment	None
Prerequisite Procedures	DLP-G46 Log into CTC, page 2-25
Required/As Needed	As needed
Onsite/Remote	Onsite or remote
Security Level	Superuser

Note

You must add the same user name and password to each node that the user will access.

- Step 1** From the View menu, choose **Go to Network View**. Verify that you can access all the nodes where you want to change the users.
- Step 2** Click the **Provisioning > Security > Users** tabs. Highlight the user's name whose settings you want to change.
- Step 3** Click **Change**. The Change User dialog box appears.
- Step 4** In the Change User dialog box, you can:
- Change a user's password.
 - Modify the user's security level.
 - Lock out the user.
 - Disable the user.
 - Force the user to change password on next login.

See the “[DLP-G55 Create a New User on Multiple Nodes](#)” task on page 3-9 for field descriptions.

- Step 5** In the Select Applicable Nodes area, uncheck any nodes where you do not want to change the user's settings (all network nodes are selected by default).

Note

The Select Applicable Nodes area does not appear for users who are provisioned for only one node.

- Step 6** Click **OK**. A Change Results confirmation dialog box appears.
- Step 7** Click **OK** to acknowledge the changes.
- Step 8** Return to your originating procedure (NTP).

DLP-G193 Delete a User From a Single Node

Purpose	This task deletes an existing user from a single node.
Tools/Equipment	None
Prerequisite Procedures	DLP-G46 Log into CTC, page 2-25

Required/As Needed	As needed
Onsite/Remote	Onsite or remote
Security Level	Superuser

**Note**

You cannot delete a user who is currently logged in. To log out a user, you can complete the [“DLP-G195 Log Out a User on a Single Node” task on page 10-57](#), or you can choose the “Logout before delete” option in the Delete User dialog box.

**Note**

CTC will allow you to delete other Superusers if one Superuser remains. For example, you can delete the CISCO15 user if you have created another Superuser. Use this option with caution.

-
- Step 1** In node view (single-shelf mode) or multishelf view (multishelf mode), click the **Provisioning > Security > Users** tabs.
- Step 2** Choose the user that you want to delete.
- Step 3** Click **Delete**.
- Step 4** In the Delete User dialog box, verify that the user name displayed is the one that you want to delete. Click **Logout before delete** if the user is currently logged in. (You cannot delete users if they are logged in.)
- Step 5** Click **OK**.
- Step 6** In the User Deletion Results box, click **OK**.
- Step 7** Return to your originating procedure (NTP).
-

DLP-G194 Delete a User From Multiple Nodes

Purpose	This task deletes an existing user from multiple nodes.
Tools/Equipment	None
Prerequisite Procedures	DLP-G46 Log into CTC, page 2-25
Required/As Needed	As needed
Onsite/Remote	Onsite or remote
Security Level	Superuser

**Note**

You cannot delete a user who is currently logged in. To log out a user, you can complete the [“DLP-G196 Log Out a User on Multiple Nodes” task on page 10-58](#), or you can choose the “Logout before delete” option in the Delete User dialog box.

**Note**

CTC will allow you to delete other Superusers if one Superuser remains. For example, you can delete the CISCO15 user if you have created another Superuser. Use this option with caution.

-
- Step 1** From the View menu, choose **Go to Network View**.

- Step 2** Click the **Provisioning > Security** tabs. Highlight the name of the user you want to delete.
- Step 3** Click **Delete**. The Delete User dialog box appears.
- Step 4** In the Select Applicable Nodes area, uncheck any nodes where you do not want to delete this user.



Note The Select Applicable Nodes area does not appear for users who are provisioned for only one node.

- Step 5** Click **OK**. A User Deletion Results confirmation dialog box appears.
- Step 6** Click **OK** to acknowledge the changes.
- Step 7** Return to your originating procedure (NTP).

DLP-G195 Log Out a User on a Single Node

Purpose	This task logs out a user from a single node.
Tools/Equipment	None
Prerequisite Procedures	DLP-G46 Log into CTC, page 2-25
Required/As Needed	As needed
Onsite/Remote	Onsite or remote
Security Level	Superuser

- Step 1** In node view (single-shelf mode) or multishelf view (multishelf mode), click the **Provisioning > Security > Active Logins** tabs.
- Step 2** Choose the user that you want to log out and click **Logout**.
- Step 3** In the Logout User dialog box, check **Lockout before Logout** if you want to lock the user out. This prevents the user from logging in after logout based on user lockout parameters provisioned in the Policy tab. A manual unlock by a Superuser is required, or else the user is locked out for the amount of time specified in the Lockout Duration field. See the [“DLP-G188 Change Security Policy for a Single Node” task on page 10-49](#) for more information.
- Step 4** Click **OK**.
- Step 5** Click **OK** to confirm the logout.
- Step 6** Return to your originating procedure (NTP).

DLP-G196 Log Out a User on Multiple Nodes

Purpose	This task logs out a user from multiple nodes.
Tools/Equipment	None
Prerequisite Procedures	DLP-G46 Log into CTC, page 2-25
Required/As Needed	As needed
Onsite/Remote	Onsite or remote
Security Level	Superuser

-
- Step 1** From the View menu, chose **Go to Network View**.
- Step 2** Click the **Provisioning > Security > Active Logins** tabs.
- Step 3** Choose the user that you want to log out.
- Step 4** Click **Logout**.
- Step 5** In the Logout User dialog box, check the nodes where you want to log out the user.
- Step 6** Check **Lockout before Logout** if you want to lock the user out prior to logout. This prevents the user from logging in after logout based on user lockout parameters provisioned in the Policy tab. A manual unlock by a Superuser is required, or else the user is locked out for the amount of time specified in the Lockout Duration field. See the “[DLP-G189 Change Security Policy for Multiple Nodes](#)” task on [page 10-50](#) for more information.
- Step 7** In the Select Applicable Nodes area, uncheck any nodes where you do not want to change the user’s settings (all network nodes are selected by default).
- Step 8** Click **OK**.
- Step 9** Click **OK** in the confirmation dialog box.
- Step 10** Return to your originating procedure (NTP).
-

DLP-G281 Configure the Node for RADIUS Authentication

Purpose	This task allows you to configure a node for Remote Authentication Dial In User Service (RADIUS) authentication. RADIUS validates remote users who are attempting to connect to the network.
Tools/Equipment	None
Prerequisite Procedures	DLP-G46 Log into CTC, page 2-25 Before configuring the node for RADIUS authentication, you must first add the node as a network device on the RADIUS server. Refer to the <i>User Guide for Cisco Secure ACS for Windows Server</i> for more information about configuring a RADIUS server.
Required/As Needed	As needed
Onsite/Remote	Onsite or remote
Security Level	Superuser

**Caution**

Do not configure a node for RADIUS authentication until after you have added that node to the RADIUS server and added the RADIUS server to the list of authenticators. If you do not add the node to a RADIUS server prior to activating RADIUS authentication, no user will be able to access the node. Refer to the *User Guide for Cisco Secure ACS for Windows Server* for more information about adding a node to a RADIUS server.

**Note**

The following Cisco vendor-specific attribute (VSA) needs to be specified when adding users to the RADIUS server:

```
shell:priv-lvl=N
```

where *N* is equal to:

- 0 for Retrieve user
- 1 for Maintenance user
- 2 for Provisioning user
- 3 for Superuser

Step 1 In node view (single-shelf mode) or multishelf view (multishelf mode), click the **Provisioning > Security > RADIUS Server** tabs (Figure 10-5).

Figure 10-5 RADIUS Server Tab

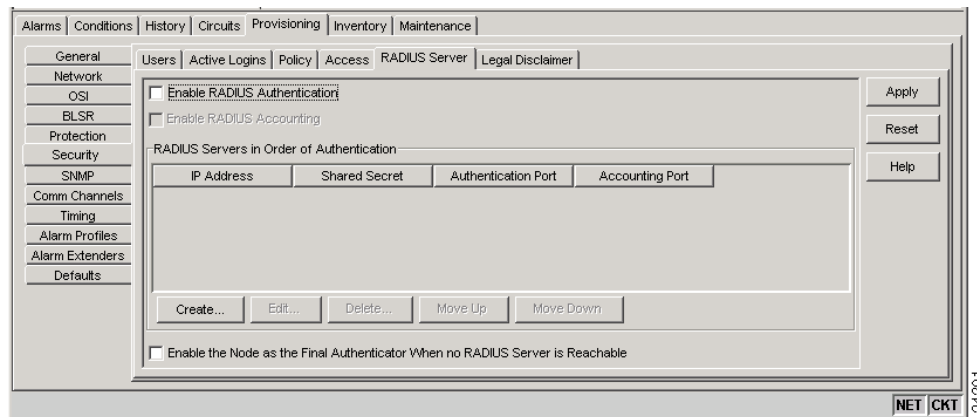

Step 2 Click **Create** to add a RADIUS server to the list of authenticators. The Create RADIUS Server Entry dialog box appears (Figure 10-6).

Figure 10-6 Create RADIUS Server Entry Window

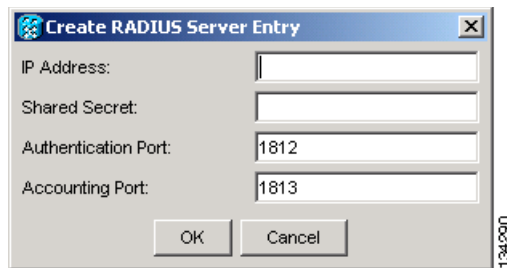

- Step 3** Enter the RADIUS server IP address in the IP Address field. If the node is an end network element (ENE), enter the IP address of the gateway network element (GNE) in this field.

The GNE passes authentication requests from the ENEs in its network to the RADIUS server, which grants authentication if the GNE is listed as a client on the server.

**Caution**

Because the ENE nodes use the GNE to pass authentication requests to the RADIUS server, you must add the ENEs to the RADIUS server individually for authentication. If you do not add the ENE node to a RADIUS server prior to activating RADIUS authentication, no user will be able to access the node. Refer to the *User Guide for Cisco Secure ACS for Windows Server* for more information about adding a node to a RADIUS server.

- Step 4** Enter the shared secret in the Shared Secret field. A shared secret is a text string that serves as a password between a RADIUS client and RADIUS server.
- Step 5** Enter the RADIUS authentication port number in the Authentication Port field. The default port is 1812. If the node is an ENE, set the authentication port to a number within the range of 1860 to 1869.
- Step 6** Enter the RADIUS accounting port in the Accounting Port field. The default port is 1813. If the node is an ENE, set the accounting port to a number within the range of 1870 to 1879.
- Step 7** Click **OK**. The RADIUS server is added to the list of RADIUS authenticators.



Note You can add up to 10 RADIUS servers to a node's list of authenticators.

- Step 8** Click **Edit** to make changes to an existing RADIUS server. You can change the IP address, the shared secret, the authentication port, and the accounting port.
- Step 9** Click **Delete** to delete the selected RADIUS server.
- Step 10** Select a server and click **Move Up** or **Move Down** to reorder that server in the list of RADIUS authenticators. The node requests authentication from the servers sequentially from top to bottom. If one server is unreachable, the node will request authentication from the next RADIUS server on the list.
- Step 11** Click the **Enable RADIUS Authentication** check box to activate remote-server authentication for the node.
- Step 12** Click the **Enable RADIUS Accounting** check box if you want to show RADIUS authentication information in the audit trail.
- Step 13** Click the **Enable the Node as the Final Authenticator** check box if you want the node to be the final authenticator. This means that if every RADIUS authenticator is unavailable, the node will authenticate the login rather than locking the user out.
- Step 14** Click **Apply** to save all changes or **Reset** to clear all changes.

Step 15 Return to your originating procedure (NTP).

DLP-G282 View and Terminate Active Logins

Purpose	This procedure allows you to view active CTC logins, retrieve the last activity time, and terminate all current logins.
Tools/Equipment	None
Prerequisite Procedures	DLP-G46 Log into CTC, page 2-25
Required/As Needed	As needed
Onsite/Remote	Onsite or remote
Security Level	Retrieve or higher for viewing; Superuser for session termination

- Step 1** In node view (single-shelf mode) or multishelf view (multishelf mode), click the **Provisioning > Security > Active Logins** tabs. The Active Logins tab displays the following information:
- User ID
 - User IP address
 - Current node the user is logged into
 - Session Type (EMS, TL1, FTP, Telnet, or SSH)
 - Login time
 - Last activity time
- Step 2** Click **Logout** to end the session of every logged-in user. This will log out all current users, excluding the initiating Superuser.
- Step 3** Click **Retrieve Last Activity Time** to display the most recent activity date and time for users in the Last Activity Time field.
- Step 4** Return to your originating procedure (NTP).
-

NTP-G131 Convert DWDM Nodes to Hybrid Nodes

Purpose	This procedure converts a DWDM node to a hybrid (DWDM and TDM) node. The conversion may require you to replace OSCM cards with OSC-CSM cards. OSCM cards use Slots 8 and 10, which are required for cross-connect cards in TDM and DWDM hybrid configurations. The OSC-CSM cards can be installed in Slots 1 to 6 or 12 to 17.
Tools/Equipment	Two OSC-CSM cards
Prerequisite Procedures	None
Required/As Needed	As needed
Onsite/Remote	Onsite
Security Level	Maintenance or higher

**Note**

You cannot perform this upgrade on software released prior to Software Release 4.6.

**Note**

Downgrade procedures from OSC-CSM cards to OSCM cards are not supported. Contact the Cisco Technical Assistance Center (TAC) for more information. See the [“Obtaining Documentation and Submitting a Service Request”](#) section on page iv.

- Step 1** Complete the [“DLP-G46 Log into CTC”](#) task on page 2-25 at the node where you will perform the upgrade. If you are already logged in, continue with Step 2.
- Step 2** Complete the [“NTP-G103 Back Up the Database”](#) procedure on page 13-2.
- Step 3** If you have timing set up on the OSCM card, delete the timing source:
- In node view (single-shelf mode) or shelf view (multishelf mode), click the **Provisioning > Timing** tabs.
 - Scroll to the Reference Lists area.
 - In the NE Reference column, select **Internal Clock** from the drop-down list for all entries where the selected Clock Source is the OSCM that you are removing.
 - Click **Apply**.
- Step 4** If you have overhead circuits on the node, complete the [“DLP-G112 Delete Overhead Circuits”](#) task on page 7-29.
- Step 5** Delete the DWDM ring ID:
- In node view (single-shelf mode) or multishelf view (multishelf mode), click the **Provisioning > Comm Channels > OSC** tabs.
 - Select the DWDM Ring ID that you want to delete and click **Delete**.
 - In the Delete DWDM Ring ID confirmation box, click **Yes**. Confirm that the changes appear.
- Step 6** If you have OSC terminations, refer to the [“DLP-G186 Delete an OSC Termination”](#) task on page 10-44 to delete the OSC termination.
- Step 7** Delete the OSCM card wavelength division multiplexing-automatic node setup (WDM-ANS) connections:
- In node view (single-shelf mode) or multishelf view (multishelf mode), click the **Provisioning > WDM-ANS > Internal Patchcords** tabs.
 - Select the connection to be deleted.
 - Click **Delete**.
 - In the Delete Optical Link dialog box, click **Yes**.
- Step 8** Delete the card from CTC:
- In node view (single-shelf mode) or shelf view (multishelf mode), right-click the OSCM card.
 - Select **Delete Card** from the shortcut menu.
- The card name disappears and the slot turns gray.
- Step 9** Remove the cables from the OSCM OSC ports.
- Step 10** Physically replace the deleted OSCM card on the ONS 15454 with an OSC-CSM card:



Note The OSCM card and OSC-CSM card do not have the same slot requirements.

- a. Open the OSCM card ejectors.
- b. Slide the card out of Slot 8 or 10.
- c. Open the ejectors on the OSC-CSM card.
- d. Slide the OSC-CSM card into the slot along the guide rails in the slots directed by your site plan.
- e. Close the ejectors.



Note On the OSC-CSM card, the fail LED above the ACT/STBY LED becomes red, blinks for several seconds, and turns off. The ACT/STBY LED turns green and remains on. In node view (single-shelf mode) or shelf view (multishelf mode), the OSC-CSM appears green.

Step 11 If an OSCM card was removed from Slot 8 and an OSC-CSM card was installed in Slots 12 to 17, modify the OSC-CSM line direction from east-to-west to west-to-east.



Note The Cisco MetroPlanner configuration file labels the OSC-CSM card as west even if it is installed in the east side of the node.

- a. To modify the OSC-CSM card line direction, double-click the OSC-CSM card in node view (single-shelf mode) or shelf view (multishelf mode). The card view appears.
 - a. Click the **Provisioning > Optical Line > Parameter** tabs.
 - b. In the Port 2 line, click the Line Direction drop-down list and choose **West to East**.
 - c. Click **Apply**.

Step 12 If an OSCM card was removed from Slot 10 and an OSC-CSM card was installed in Slots 1 to 6, modify the OSC-CSM line direction from west-to-east to east-to-west.



Note The Cisco MetroPlanner configuration file will label the OSC-CSM card as east even if it is installed in the west side of the node.

- a. To modify the OSC-CSM card line direction, double-click the OSC-CSM card in node view (single-shelf mode) or shelf view (multishelf mode). The card view appears.
 - b. Click the **Provisioning > Optical Line > Parameter** tabs.
 - c. In the Port 2 line, click the Line Direction drop-down list and choose **East to West**.
 - d. Click **Apply**.

Step 13 Verify the default internal patchcords:

- a. Click the CTC up arrow to return to node view or multishelf view.
 - a. Click the **Provisioning > WDM-ANS > Internal Patchcords** tabs.
 - b. Click **Default Patchcords**.

Step 14 Connect the cables from the OSC-CSM LINE ports to the OPT-BST amplifier OSC ports. Follow the recommended connections that were automatically calculated in the Internal Patchcords tab as described in Step 13.

- Step 15** Launch ANS port regulation:
- Click the **Provisioning > WDM-ANS > Port Status** tabs.
 - Click the **Launch ANS** button.
 - In the Link Status column, the ports change to Regulated.
- Step 16** Create OSC terminations starting from the OSC-CSM card. See the [“NTP-G38 Provision OSC Terminations” task on page 3-83](#).
- Step 17** (Optional) If you want to set up timing on the OSC-CSM card, create the timing source:
- In node view (single-shelf mode) or shelf view (multishelf mode), click the **Provisioning > Timing** tabs.
 - Scroll down to the Reference Lists area.
 - In the NE Reference column, select **Internal Clock** from the drop-down list for all entries where the selected Clock Source is the OSC-CSM that you are adding.
 - Click **Apply**.
- Step 18** (Optional) Complete the [“NTP-G60 Create and Delete Overhead Circuits” procedure on page 7-21](#).
- Step 19** Repeat Steps 3 through 18 for each OSCM card you are replacing in the node.
- Step 20** If you are installing cross-connect cards, refer to the *Cisco ONS 15454 Procedure Guide* or the *Cisco ONS 15454 SDH Procedure Guide* for instructions.
- Stop. You have completed this procedure.**
-

NTP-G89 Change SNMP Settings

Purpose	This procedure modifies the SNMP settings for the ONS 15454.
Tools/Equipment	None
Prerequisite Procedures	NTP-G28 Set Up SNMP, page 3-36
Required/As Needed	As needed
Onsite/Remote	Onsite or remote
Security Level	Provisioning or higher

- Step 1** Complete the [“DLP-G46 Log into CTC” task on page 2-25](#). If you are already logged in, continue with Step 2.
- Step 2** Complete the [“NTP-G103 Back Up the Database” procedure on page 13-2](#).
- Step 3** Perform any of the following tasks as needed:
- [DLP-G197 Modify SNMP Trap Destinations, page 10-65](#)
 - [DLP-G198 Delete SNMP Trap Destinations, page 10-66](#)
- Step 4** Complete the [“NTP-G103 Back Up the Database” procedure on page 13-2](#).
- Stop. You have completed this procedure.**
-

DLP-G197 Modify SNMP Trap Destinations

Purpose	This task modifies the SNMP trap destinations on an ONS 15454 including community name, default User Datagram Protocol (UDP) port, SNMP trap version, and maximum traps per second.
Tools/Equipment	None
Prerequisite Procedures	DLP-G46 Log into CTC, page 2-25
Required/As Needed	As needed
Onsite/Remote	Onsite or remote
Security Level	Provisioning or higher

-
- Step 1** In node view (single-shelf mode) or multishelf view (multishelf mode), click the **Provisioning > SNMP** tabs.
- Step 2** Select a trap from the **Trap Destinations** area.
For a description of SNMP traps, refer to the *Cisco ONS 15454 DWDM Reference Manual*.
- Step 3** Highlight the Destination row field entry in the Community column and change the entry to another valid community name.

The community name is a form of authentication and access control. The community name assigned to the ONS 15454 is case-sensitive and must match the community name of the network management system (NMS).
- Step 4** If needed, modify the UDP port in the UDP Port field. The default UDP port for SNMP is 162.
- Step 5** Set the Trap Version field for either SNMPv1 or SNMPv2.
Refer to your NMS documentation to determine whether to use SNMPv1 or SNMPv2.
- Step 6** If you want the SNMP agent to accept SNMP SET requests on certain MIBs, click the **Allow SNMP Sets** check box. If this box is not checked, SET requests are rejected.
- Step 7** If you want to set up the SNMP proxy feature to allow network management, message reporting, and performance statistics retrieval across ONS firewalls, click the **Enable SNMP Proxy** check box located on the SNMP tab.
- Step 8** Click **Apply**.
- Step 9** SNMP settings are now modified. To view SNMP information for each node, highlight the node IP address in the Trap Destinations area of the Trap Destinations area. Confirm that the changes appear; if not, repeat the task.
- Step 10** Return to your originating procedure (NTP).
-

DLP-G198 Delete SNMP Trap Destinations

Purpose	This task deletes SNMP trap destinations on an ONS 15454.
Tools/Equipment	None
Prerequisite Procedures	DLP-G46 Log into CTC, page 2-25
Required/As Needed	As needed
Onsite/Remote	Onsite or remote
Security Level	Provisioning or higher

-
- Step 1** In node view (single-shelf mode) or multishelf view (multishelf mode), click the **Provisioning > SNMP** tabs.
 - Step 2** In the Trap Destinations area, click the trap that you want to delete.
 - Step 3** Click **Delete**. A confirmation dialog box appears.
 - Step 4** Click **Yes**. Confirm that the changes appear; if not, repeat the task.
 - Step 5** Return to your originating procedure (NTP).
-



Change DWDM Card Settings

This chapter explains how to change line, performance monitoring (PM), and threshold settings on Cisco ONS 15454 optical service, amplifier, multiplexer, demultiplexer, 32WSS, MMU, and AIC-I cards. To install DWDM cards, see the [“NTP-G30 Install the DWDM Cards” procedure on page 3-44](#).



Note

Unless otherwise specified, “ONS 15454” refer to both ANSI and ETSI shelf assemblies.



Note

Unless otherwise specified, card parameters apply to cards installed in both ANSI and ETSI shelf assemblies.

Before You Begin

Before performing any of the following procedures, investigate all alarms and clear any trouble conditions. Refer to the *Cisco ONS 15454 DWDM Troubleshooting Guide* as necessary.



Caution

Changing card settings can be service affecting. You should make all changes during a scheduled maintenance window.

This section lists the chapter procedures (NTPs). Turn to a procedure for applicable tasks (DLPs).

1. [NTP-G90 Modify OSCM and OSC-CSM Card Line Settings and PM Thresholds, page 11-2](#)—As needed, complete this procedure to change the OSCM and OSC-CSM card settings.
2. [NTP-G91 Modify OPT-PRE and OPT-BST Card Line Settings and PM Thresholds, page 11-13](#)—As needed, complete this procedure to change the OPT-PRE and OPT-BST amplifier card settings.
3. [NTP-G160 Modify OPT-AMP-L Card Line Settings and PM Thresholds, page 11-25](#)—As needed, complete this procedure to change the OPT-AM-L amplifier card settings.
4. [NTP-G92 Modify 32MUX-O, 32DMX-O, 32DMX, 32DMX-L, and 4MD Line Card Settings and PM Thresholds, page 11-38](#)—As needed, complete this procedure to change the multiplexer and demultiplexer card settings.
5. [NTP-G93 Modify the 32WSS and 32WSS-L Line Settings and PM Thresholds, page 11-48](#)—As needed, complete this procedure to change the 32WSS and 32WSS-L card settings.
6. [NTP-G149 Modify the MMU Line Settings and PM Thresholds, page 11-58](#)—As needed, complete this procedure to change the MMU card settings.

7. [NTP-G101 Modify Alarm Interface Controller–International Settings, page 11-62](#)—As needed, complete this procedure to change settings for external alarms, controls, and orderwire for the AIC-I card.
8. [NTP-G102 Change Card Service State, page 11-65](#)—As needed, complete this procedure to change the card service state.

NTP-G90 Modify OSCM and OSC-CSM Card Line Settings and PM Thresholds

Purpose	This procedure changes the optical service channel (OC-3/STM-1) and PM parameters and thresholds for the OSCM and OSC-CSM cards.
Tools/Equipment	None
Prerequisite Procedures	NTP-G30 Install the DWDM Cards, page 3-44
Required/As Needed	As needed
Onsite/Remote	Onsite or remote
Security Level	Provisioning or higher

-
- Step 1** Complete the “[DLP-G46 Log into CTC](#)” task on page 2-25 at the node where you want to change the OSCM or OSC-CSM card settings. If you are already logged in, proceed to [Step 2](#).
- Step 2** Complete the “[NTP-G103 Back Up the Database](#)” procedure on page 13-2.
- Step 3** Perform any of the following tasks as needed:
- [DLP-G199 Change the OSCM and OSC-CSM Optical Service Channel Settings, page 11-2](#)
 - [DLP-G200 Change the OSCM and OSC-CSM Optical Service Channel Thresholds, page 11-5](#)
 - [DLP-G201 Change Optical Line Parameters for OSCM and OSC-CSM Cards, page 11-6](#)
 - [DLP-G202 Change the OSCM and OSC-CSM Optical Line Threshold Settings, page 11-8](#)
 - [DLP-G203 Change the OSCM and OSC-CSM ALS Maintenance Settings, page 11-12](#)
- Step 4** Complete the “[NTP-G103 Back Up the Database](#)” procedure on page 13-2.
- Stop. You have completed this procedure.**
-

DLP-G199 Change the OSCM and OSC-CSM Optical Service Channel Settings

Purpose	This task changes the OC-3/STM-1 optical service channel (OSC) settings for OSCM and OSC-CSM cards.
Tools/Equipment	None
Prerequisite Procedures	DLP-G46 Log into CTC, page 2-25
Required/As Needed	As needed
Onsite/Remote	Onsite or remote
Security Level	Provisioning or higher

- Step 1** In node view (single-shelf mode) or shelf view (multishelf view), double-click the OSCM or OSC-CSM card where you want to change the OC-3 optical line settings.
- Step 2** Click the **Provisioning > OC3 Line > OC3 Line (ANSI)** or **Provisioning > STM-1 > STM-1 Line (ETSI)** tabs.
- Step 3** Modify any of the settings described in [Table 11-1](#). The provisionable parameters are listed in the Options column.

Table 11-1 OSCM and OSC-CSM Card OC-3/STM-1 Settings

Parameter	Description	Options
Port	(Display only) Displays the port number, 1.	—
Port Name	Provides the ability to assign the specified port a name.	User-defined. Name can be up to 32 alphanumeric/special characters. Blank by default. See the “ DLP-G104 Assign a Name to a Port ” task on page 7-3 .
Admin State	(Display only) Displays the port admin state. For more information about administrative states, see the “Administrative and Service States” appendix in the <i>Cisco ONS 15454 DWDM Reference Manual</i> .	<ul style="list-style-type: none"> IS (ANSI) or Unlocked (ETSI)—Puts the port in service. The port service state changes to IS-NR (ANSI) or Unlocked-enabled (ETSI). IS,AINS (ANSI) or Unlocked,automaticInService (ETSI)—Puts the port in automatic in-service. The port service state changes to OOS-AU,AINS (ANSI) or Unlocked-disabled,automaticInService (ETSI).
Service State	(Display only) Identifies the autonomously generated state that gives the overall condition of the port. Service states appear in the format: Primary State-Primary State Qualifier, Secondary State. For more information about service states, see “Administrative and Service States” appendix in the <i>Cisco ONS 15454 DWDM Reference Manual</i> .	<ul style="list-style-type: none"> IS-NR (In-Service and Normal [ANSI]) or Unlocked-enabled (ETSI)—The port is fully operational and is performing as provisioned. OOS-AU,AINS (Out-Of-Service and Autonomous, Automatic In-Service [ANSI]) or Unlocked-disabled,automaticInService (ETSI)—The port is out of service, but traffic is carried. Alarm reporting is suppressed. The ONS node monitors the ports for an error-free signal. After an error-free signal is detected, the port stays in the OOS-AU,AINS/Unlocked-disabled,automaticInService state for the duration of the soak period. After the soak period ends, the port service state changes to IS-NR/Unlocked-enabled. OOS-MA,DSBLD (Out-of-Service and Management, Disabled [ANSI]) or Locked-enabled,disabled (ETSI)—The port is out of service and unable to carry traffic. OOS-MA,MT (Out-of-Service and Management, Maintenance [ANSI]) or Locked-enabled,maintenance (ETSI)—The port is out of service for maintenance. Alarm reporting is suppressed, but traffic is carried and loopbacks are allowed.

Table 11-1 OSCM and OSC-CSM Card OC-3/STM-1 Settings (continued)

Parameter	Description	Options
SF BER	Sets the signal fail bit error rate.	From the drop-down list, choose one of the following: <ul style="list-style-type: none"> • 1E-3 • 1E-4 • 1E-5
SD BER	Sets the signal degrade bit error rate.	From the drop-down list, choose one of the following: <ul style="list-style-type: none"> • 1E-5 • 1E-6 • 1E-7 • 1E-8 • 1E-9
Provides Synch	(Display only) If checked, the card is provisioned as a network element (NE) timing reference.	<ul style="list-style-type: none"> • Checked • Unchecked
SyncMsgIn	Enables synchronization status messages (SSM) on the S1 byte, which allow the node to choose the best timing source.	<ul style="list-style-type: none"> • Checked • Unchecked
Send Do Not Use	When checked, sends a Do Not Use for Synchronization (DUS) message on the S1 byte.	<ul style="list-style-type: none"> • Checked • Unchecked
PJSTSMon #	(Display only) Sets the STS that will be used for pointer justification.	This parameter is set to Off. It cannot be changed.
AINS Soak	(Display only) The automatic in-service soak period. It is always 00.00.	—
Type	Defines the port as SONET or SDH. The Enable Sync Msg field and the Send Do Not Use field must be disabled before the port can be set to SDH.	From the drop-down list, choose one of the following: <ul style="list-style-type: none"> • SONET • SDH

Step 4 Click **Apply**. If the change affects traffic, a warning message displays. Click **Yes** to complete the change.

Step 5 Return to your originating procedure (NTP).

DLP-G200 Change the OSCM and OSC-CSM Optical Service Channel Thresholds

Purpose	This task changes the OC-3 (STM-1) SONET (SDH) thresholds settings for the OSC signal transmitted by the OSCM and OSC-CSM cards.
Tools/Equipment	None
Prerequisite Procedures	DLP-G46 Log into CTC, page 2-25
Required/As Needed	As needed
Onsite/Remote	Onsite or remote
Security Level	Provisioning or higher

- Step 1** In node view (single-shelf mode) or shelf view (multishelf view), double-click the OSCM or OSC-CSM card where you want to change the optical line threshold settings.
- Step 2** Click the **Provisioning > OC3 Line > SONET Thresholds (ANSI)** or **Provisioning > OC3 Line > SDH Thresholds (ETSI)** tabs.
- Step 3** Modify any of the settings described in [Table 11-2 \(ANSI\)](#) or [Table 11-3 \(ANSI\)](#). The provisionable parameters are listed in the Options column in the table.

Table 11-2 *OSCM and OSC-CSM Cards SONET Threshold Settings*

Parameter	Description	Options
Port	(Display only) Displays the port number, 1	—
CV	Coding violations	Numeric. Can be set for 15-minute or one-day intervals for Line or Section (Near and Far End). Select the bullet and click Refresh .
ES	Errored seconds	Numeric. Can be set for 15-minute or one-day intervals for Line or Section (Near and Far End). Select the bullet and click Refresh .
SES	Severely errored seconds	Numeric. Can be set for 15-minute or one-day intervals for Line or Section (Near and Far End). Select the bullet and click Refresh .
SEFS	Severely errored framing seconds (Section only)	Numeric. Can be set for Far End, for 15-minute or one-day intervals for Section only. Select the bullet and click Refresh .
FC	Failure count (Line only)	Numeric. Can be set for 15-minute or one-day intervals for Line. Select the bullet and click Refresh (Near and Far End).
UAS	Unavailable seconds (Line only)	Numeric. Can be set for 15-minute or one-day intervals for Line (Near and Far End). Select the bullet and click Refresh .

Table 11-3 OSCM and OSC-CSM Cards SDH Threshold Settings

Parameter	Description	Options
Port	(Display only) Displays the port number, 1	—
EB	Errored block	Numeric. Can be set for 15-minute or one-day intervals for MS (Multiplex Section) or RS (Regeneration Section) (Near and Far End). Select the bullet and click Refresh .
ES	Errored seconds	Numeric. Can be set for 15-minute or one-day intervals for MS (Multiplex Section) or RS (Regeneration Section) (Near and Far End). Select the bullet and click Refresh .
SES	Severely errored seconds	Numeric. Can be set for 15-minute or one-day intervals for MS or RS (Near and Far End). Select the bullet and click Refresh .
BBE	Background block error	Numeric. Can be set for 15-minute or one-day intervals for MS or RS (Near and Far End). Select the bullet and click Refresh .
OFS		Numeric. Can be set for 15-minute or one-day intervals for RS, Near End. Select the bullet and click Refresh .
UAS	Unavailable seconds	Numeric. Can be set for 15-minute or one-day intervals for MS or RS (Near and Far End). Select the bullet and click Refresh .

- Step 4** Click **Apply**. If the change affects traffic, a warning message displays. Click **Yes** to complete the change.
- Step 5** Return to your originating procedure (NTP).

DLP-G201 Change Optical Line Parameters for OSCM and OSC-CSM Cards

Purpose	This task changes the optical line parameters for OSCM and OSC-CSM cards.
Tools/Equipment	None
Prerequisite Procedures	DLP-G46 Log into CTC, page 2-25
Required/As Needed	As needed
Onsite/Remote	Onsite or remote
Security Level	Provisioning or higher

- Step 1** In node view (single-shelf mode) or shelf view (multishelf mode), double-click the OSCM or OSC-CSM card where you want to change the optical line parameters.
- Step 2** Click the **Provisioning > Optical Line > Parameters** tabs.
- Step 3** Modify any of the settings described in [Table 11-4](#). The provisionable parameters are listed in the Options column in the table. In the Options column, the SONET (ANSI) option is followed by the SDH (ETSI) option.

Table 11-4 OSCM and OSC-CSM Card Optical Line Parameter Settings

Parameter	Description	Options
Port	(Display only) Displays the port number, port type, and direction (TX or RX): OSCM <ul style="list-style-type: none"> • 2 (OSC-RX) • 3 (OSC-TX) OSC-CSM <ul style="list-style-type: none"> • 2 (COM-RX) • 3 (COM-TX) • 4 (LINE-RX) • 5 (LINE-TX) • 6 (OSC-RX) • 6 (OSC-TX) 	—
Port Name	Provides the ability to assign the specified port a name.	User-defined. Name can be up to 32 alphanumeric/special characters. Blank by default. See the “DLP-G104 Assign a Name to a Port” task on page 7-3 .
Admin State	Sets the port service state unless network conditions prevent the change. For more information about administrative states, refer to the “Administrative and Service States” appendix in the <i>Cisco ONS 15454 DWDM Reference Manual</i> .	From the drop-down list, choose one of the following: <ul style="list-style-type: none"> • IS,AINS/Unlocked,automaticInService • OOS,DSBLD/Locked,disabled • OOS,MT/Locked,maintenance
Service State	(Display only) Identifies the autonomously generated state that gives the overall condition of the port. Service states appear in the format: Primary State-Primary State Qualifier, Secondary State. For more information about service states, refer to the “Administrative and Service States” appendix in the <i>Cisco ONS 15454 DWDM Reference Manual</i> .	<ul style="list-style-type: none"> • IS-NR/Unlocked-enabled • OOS-AU,AINS/Unlocked-disabled,automaticInService • OOS-MA,DSBLD/Locked-enabled,disabled • OOS-MA,MT/Locked-enabled,maintenance
Line Direction	Shows the line direction associated with the optical signal that passes through the port. This parameter is automatically configured during ANS. To change it, you must modify the network plan in Cisco MetroPlanner, import the NE Update file and run ANS.	<ul style="list-style-type: none"> • East to West • West to East The options cannot be modified.
Power	(Display only) Shows the current power level per port.	—
VOA Mode	(Display only) Shows the functional mode of the variable optical attenuator (VOA), when present.	<ul style="list-style-type: none"> • Constant Attenuation • Constant Power

Table 11-4 OSCM and OSC-CSM Card Optical Line Parameter Settings (continued)

Parameter	Description	Options
VOA Power Ref	(Display only) Shows the optical power setpoint that must be reached when a VOA is present and VOA Mode is set to Constant Power. This parameter can only be modified by Automatic Node Setup (ANS).	—
VOA Power Calib	Modifies the optical power value of the VOA when VOA Mode is set to Constant Power.	Numeric. Double-click the parameter, enter a value, and press Enter .
VOA Attenuation Ref	(Display only) Shows the VOA attenuation value when VOA Mode is set to Constant Attenuation. This parameter can only be modified by ANS.	—
VOA Attenuation Calib	Modifies the attenuation value of the VOA when the VOA Mode is set to Constant Attenuation.	Numeric. Double-click the parameter, enter a value, and press Enter .

Step 4 Click **Apply**. If the change affects traffic, a warning message displays. Click **Yes** to complete the change.

Step 5 Return to your originating procedure (NTP).

DLP-G202 Change the OSCM and OSC-CSM Optical Line Threshold Settings

Purpose	This task changes the optical line threshold settings for OSCM and OSC-CSM cards.
Tools/Equipment	None
Prerequisite Procedures	DLP-G46 Log into CTC, page 2-25
Required/As Needed	As needed
Onsite/Remote	Onsite or remote
Security Level	Provisioning or higher

Step 1 In node view (single-shelf mode) or shelf view (multishelf mode), double-click the OSCM or OSC-CSM card where you want to change the optical channel threshold settings.

Step 2 Click the **Provisioning > Optical Line > Optics Thresholds** tabs.

Step 3 Under Types, choose the type of threshold you want to change, either **Warning** or **Alarm**.



Caution Warning thresholds are not monitored by CTC. They must be user-provisioned and monitored through custom alarm profiles.

Step 4 Click **Refresh**.

Step 5 Modify any of the warning or alarm threshold settings. [Table 11-5](#) shows the thresholds for warnings. [Table 11-6](#) shows the thresholds for alarms.

Table 11-5 *OSCM and OSC-CSM Cards Optical Line Warning Thresholds Settings*

Parameter	Description	Options
Port	(Display only) Displays the port number, port type, and direction (TX or RX): OSCM <ul style="list-style-type: none"> • 2 (OSC-RX) • 3 (OSC-TX) OSC-CSM <ul style="list-style-type: none"> • 2 (COM-RX) • 3 (COM-TX) • 4 (LINE-RX) • 5 (LINE-TX) • 6 (OSC-RX) • 6 (OSC-TX) 	—
opwrMin (dBm)	Sets the low power warning level.	Numeric. Can be set for 15-minute or one-day intervals. The default is -50 dBm. Double-click the parameter, enter a value, and press Enter .
opwrMax (dBm)	Sets the high power warning level.	Numeric. Can be set for 15-minute or one-day intervals. The default is 30 dBm. Double-click the parameter, enter a value, and press Enter .

Table 11-6 OSCM and OSC-CSM Cards Optical Line Alarm Thresholds Settings

Parameter	Description	Options
Port	<p>(Display only) Displays the port number, port type, and direction (TX or RX):</p> <p>OSCM</p> <ul style="list-style-type: none"> • 2 (OSC-RX) • 3 (OSC-TX) <p>OSC-CSM</p> <ul style="list-style-type: none"> • 2 (COM-RX) • 3 (COM-TX) • 4 (LINE-RX) • 5 (LINE-TX) • 6 (OSC-RX) • 6 (OSC-TX) 	—
Power Failure Low (dBm)	<p>Shows the optical power failure low threshold for the port. The threshold is calculated automatically when you run ANS. If the VOA Mode is Constant Attenuation, you can manually change the threshold. The value must be within the optical power range that is specified for the card. (Refer to the “Hardware Specifications” appendix in the <i>Cisco ONS 15454 DWDM Reference Manual</i>.)</p> <p>If VOA Mode is Constant Power, you cannot change the threshold manually because it is based on the Power setpoint (VOA Power Ref + VOA Power Calib). To change the threshold, you must change the VOA Power Calib value. This adjusts the Power setpoint. The threshold is automatically set to a value that is 5 dB lower than the Power setpoint.</p>	Numeric (dB). Double-click the table cell, enter a value, then press Enter .

Table 11-6 *OSCM and OSC-CSM Cards Optical Line Alarm Thresholds Settings (continued)*

Parameter	Description	Options
Power Degrade High (dBm)	Shows the power degrade high threshold. This power value applies to the corresponding port and is automatically calculated when ANS is run. This threshold applies to a port that is associated to a VOA (OSC-VOA). In Constant Power mode, the port is always active and the threshold is automatically linked to the Power setpoint (VOA Power Ref + VOA Power Calib). To change the threshold, change the Power setpoint. The threshold will always be 2 dB higher than the Power setpoint.	Numeric.
Power Degrade Low (dBm)	Shows the power degrade low threshold. This power value applies to the corresponding port and is automatically calculated when ANS is run. This threshold applies to a port associated to a VOA (OSC-VOA) always active in Constant Power mode. In this case, the threshold is automatically linked to the Power setpoint (VOA Power Ref + VOA Power Calib) that is provisioned. Changing the setpoint will result in changing the threshold (always 2 dB lower).	Numeric.
VOA Degrade High (dBm)	Does not apply to OSCM and OSC-CSM cards.	—
VOA Degrade Low (dBm)	Does not apply to OSCM and OSC-CSM cards.	—

Step 6 Click **Apply**. If the change affects traffic, a warning message displays. Click **Yes** to complete the change.

Step 7 Return to your originating procedure (NTP).

DLP-G203 Change the OSCM and OSC-CSM ALS Maintenance Settings

Purpose	This task changes the automatic laser shutdown (ALS) maintenance settings for the OSC-CSM and OSCM cards.
Tools/Equipment	None
Prerequisite Procedures	DLP-G46 Log into CTC, page 2-25
Required/As Needed	As needed
Onsite/Remote	Onsite or remote
Security Level	Provisioning or higher



Note

The automatic laser shutdown (ALS) function should only be disabled temporarily for installation or maintenance reasons. Activate ALS immediately after maintenance or installation.



Warning

Invisible laser radiation could be emitted from the end of the unterminated fiber cable or connector. Do not stare into the beam directly with optical instruments. Viewing the laser output with certain optical instruments (for example, eye loupes, magnifiers, and microscopes) within a distance of 100 mm could pose an eye hazard. Statement 1056

- Step 1** In node view (single-shelf mode) or shelf view (multishelf mode), double-click the OSC-CSM or OSCM card where you want to change the ALS maintenance settings.
- Step 2** Click the **Maintenance > ALS** tabs.
- Step 3** Modify any of the settings described in [Table 11-7](#). The provisionable parameters are listed in the Options column in the table.

Table 11-7 OSC-CSM and OSCM Maintenance Settings

Parameter	Description	Options
OSRI	Optical safety remote interlock. When set to On, the OSC TX output power is shut down.	From the drop-down list, choose one of the following: <ul style="list-style-type: none"> On Off
ALS Mode	Automatic laser shutdown mode. For OSCM cards ALS provides the ability to shut down the OSC TX laser when the OSC RX detects a loss of signal (LOS). For OSC-CSM cards, ALS provides the same functions as the OSCM card and also enables an optical safety mechanism at the DWDM network layer. Refer to the “Card Reference” chapter in the <i>Cisco ONS 15454 DWDM Reference Manual</i> for more detail.	From the drop-down list, choose one of the following: <ul style="list-style-type: none"> Disable—Deactivates ALS. Auto Restart—(Default) ALS is active. The power is automatically shut down when needed and automatically tries to restart using a probe pulse until the cause of the failure is repaired. Manual Restart Manual Restart for Test

Table 11-7 OSC-CSM and OSCM Maintenance Settings (continued)

Parameter	Description	Options
Recovery Pulse Duration	(Display only) Displays the duration of the optical power pulse that begins when an amplifier restarts.	—
Recovery Pulse Interval	(Display only) Displays the interval between optical power pulses.	—
Currently Shutdown	(Display only) Displays whether or not the laser is currently shut down, either YES or NO.	—
Request Laser Restart	If checked, allows you to restart the laser.	Checked or unchecked

Step 4 Click **Apply**. If the change affects traffic, a warning message displays. Click **Yes** to complete the change.

Step 5 Return to your originating procedure (NTP).

NTP-G91 Modify OPT-PRE and OPT-BST Card Line Settings and PM Thresholds

Purpose	This procedure changes the line and threshold settings for the OPT-PRE, OPT-BST, OPT-BST-E, and OPT-BST-L amplifier cards.
Tools/Equipment	None
Prerequisite Procedures	NTP-G30 Install the DWDM Cards, page 3-44
Required/As Needed	As needed
Onsite/Remote	Onsite or remote
Security Level	Provisioning or higher

Step 1 Complete the “[DLP-G46 Log into CTC](#)” task on page 2-25 at the node where you want to change the OPT-PRE, OPT-BST, OPT-BST-E, or OPT-BST-L amplifier card settings. If you are already logged in, proceed to [Step 2](#).

Step 2 Complete the “[NTP-G103 Back Up the Database](#)” procedure on page 13-2.

Step 3 Perform any of the following tasks as needed:

- [DLP-G204 Change Optical Line Settings for OPT-PRE and OPT-BST Amplifiers, page 11-14](#)
- [DLP-G205 Change Optical Line Threshold Settings for OPT-PRE and OPT-BST Amplifiers, page 11-15](#)
- [DLP-G206 Change Optical Amplifier Line Settings for OPT-PRE and OPT-BST Amplifiers, page 11-18](#)
- [DLP-G207 Change Optical Amplifier Threshold Settings for OPT-PRE and OPT-BST Amplifiers, page 11-20](#)
- [DLP-G322 Change the OPT-BST ALS Maintenance Settings, page 11-24](#)

- Step 4** Complete the “[NTP-G103 Back Up the Database](#)” procedure on page 13-2.
Stop. You have completed this procedure.

DLP-G204 Change Optical Line Settings for OPT-PRE and OPT-BST Amplifiers

Purpose	This task changes the optical line settings for the OPT-PRE, OPT-BST, OPT-BST-E, or OPT-BST-L amplifier cards.
Tools/Equipment	None
Prerequisite Procedures	DLP-G46 Log into CTC , page 2-25
Required/As Needed	As needed
Onsite/Remote	Onsite or remote
Security Level	Provisioning or higher

- Step 1** In node view (single-shelf mode) or shelf view (multishelf mode), double-click the OPT-PRE, OPT-BST, OPT-BST-E, or OPT-BST-L amplifier where you want to change the optical line settings.
- Step 2** Click the **Provisioning > Optical Line > Parameters** tabs.
- Step 3** Modify any of the settings described in [Table 11-8](#). The provisionable parameters are listed in the Options column in the table. In the Options column, the SONET (ANSI) option is followed by the SDH (ETSI) option.

Table 11-8 OPT-PRE, OPT-BST, OPT-BST-E, and OPT-BST-L Amplifier Optical Line Settings

Parameter	Description	Options
Port	(Display only) Displays the port number, port type, and direction (TX or RX): OPT-BST, OPT-BST-E, and OPT-BST-L <ul style="list-style-type: none"> • 1 (COM-RX) • 2 (COM-TX) • 3 (OSC-RX) • 4 (OSC-TX) • 5 (LINE-RX) OPT-PRE <ul style="list-style-type: none"> • 1 (COM-RX) • 3 (DC-RX) • 4 (DC-TX) 	—
Port Name	Provides the ability to assign the specified port a name.	User-defined. Name can be up to 32 alphanumeric/special characters. Blank by default. Double-click, enter the name, and press Enter . See the “ DLP-G104 Assign a Name to a Port ” task on page 7-3.

Table 11-8 OPT-PRE, OPT-BST, OPT-BST-E, and OPT-BST-L Amplifier Optical Line Settings (continued)

Parameter	Description	Options
Admin State	Sets the port service state unless network conditions prevent the change. For more information about administrative states, refer to the “Administrative and Service States” appendix in the <i>Cisco ONS 15454 DWDM Reference Manual</i> .	From the drop-down list, choose one of the following: <ul style="list-style-type: none"> IS,AINS/Unlocked,automaticInService OOS,DSBLD/Locked,disabled OOS,MT/Locked,maintenance
Service State	(Display only) Identifies the autonomously generated state that gives the overall condition of the port. Service states appear in the format: Primary State-Primary State Qualifier, Secondary State. For more information about service states, refer to the “Administrative and Service States” appendix in the <i>Cisco ONS 15454 DWDM Reference Manual</i> .	<ul style="list-style-type: none"> IS-NR/Unlocked-enabled OOS-AU,AINS/Unlocked-disabled,automaticInService OOS-MA,DSBLD/Locked-enabled,disabled OOS-MA,MT/Locked-enabled,maintenance
Line Direction	Shows the line direction associated with the optical signal that passes through the port. This parameter is automatically configured during ANS. To change it, you must modify the network plan in Cisco MetroPlanner, import the NE Update file and run ANS.	<ul style="list-style-type: none"> East to West West to East The options cannot be modified.
Power	(Display only) Shows the current power level per port.	—
AINS Soak	(Display only) Shows the soak time, which is always 00.00.	—

Step 4 Click **Apply**. If the change affects traffic, a warning message displays. Click **Yes** to complete the change.

Step 5 Return to your originating procedure (NTP).

DLP-G205 Change Optical Line Threshold Settings for OPT-PRE and OPT-BST Amplifiers

Purpose	This task changes the optical line threshold settings for OPT-PRE, OPT-BST, OPT-BST-E, and OPT-BST-L amplifier cards.
Tools/Equipment	None
Prerequisite Procedures	DLP-G46 Log into CTC, page 2-25
Required/As Needed	As needed
Onsite/Remote	Onsite or remote
Security Level	Provisioning or higher



Caution

Warning thresholds are not monitored by CTC. They must be user-provisioned and monitored through custom alarm profiles.

- Step 1** In node view (single-shelf mode) or shelf view (multishelf mode), double-click the OPT-PRE, OPT-BST, OPT-BST-E, or OPT-BST-L amplifier where you want to change the optical line threshold settings.
- Step 2** Click the **Provisioning > Optical Line > Optics Thresholds** tabs.
- Step 3** If you want to change the warning thresholds, complete the following steps. If not, continue with [Step 4](#).
- Under Types, choose **Warning**.
 - Choose the warning interval that you want to provision, either **15 minutes** or **1 Day**.
 - Click **Refresh**.
 - Modify any of the warning thresholds shown under the Options column in [Table 11-9](#).
 - Click **Apply**. If the change affects traffic, a warning message displays. Click **Yes** to complete the change.

Table 11-9 *OPT-PRE, OPT-BST, OPT-BST-E, and OPT-BST-L Card Optical Line Warning Threshold Settings*

Parameter	Description	Options
Port	(Display only) Displays the port number, port type, and direction (TX or RX): OPT-BST, OPT-BST-E, and OPT-BST-L <ul style="list-style-type: none"> • 1 (COM-RX) • 2 (COM-TX) • 3 (OSC-RX) • 4 (OSC-TX) • 5 (LINE-RX) OPT-PRE <ul style="list-style-type: none"> • 1 (COM-RX) • 3 (DC-RX) 4 (DC-TX)	—
opwrMin (dBm)	Sets the low power warning level.	Numeric. Can be set for 15-minute or one-day intervals. The default is -50 dBm. Double-click, enter the name, and press Enter .
opwrMax (dBm)	Sets the high power warning level.	Numeric. Can be set for 15-minute or one-day intervals. The default is 30 dBm. Double-click, enter the name, and press Enter .

- Step 4** If you want to change the alarm thresholds, complete the following steps. If not, continue with [Step 5](#).
- Under Types, choose **Alarm**.
 - Click **Refresh**.
 - Modify any of the alarm thresholds shown under the Options column in [Table 11-10](#).
 - Click **Apply**. If the change affects traffic, a warning message displays. Click **Yes** to complete the change.

Table 11-10 *OPT-PRE, OPT-BST, OPT-BST-E, and OPT-BST-L Card Optical Line Alarm Threshold Settings*

Parameter	Description	Options
Port	(Display only) Displays the port number, port type, and direction (RX or TX): OPT-BST, OPT-BST-E, and OPT-BST-L <ul style="list-style-type: none"> • 1 (COM-RX) • 2 (COM-TX) • 3 (OSC-RX) • 4 (OSC-TX) • 5 (LINE-RX) OPT-PRE <ul style="list-style-type: none"> • 1 (COM-RX) • 3 (DC-RX) • 4 (DC-TX) 	—
Power Failure Low (dBm)	Shows the optical power failure low threshold for the port. The threshold is calculated automatically when you run ANS. You can manually change the threshold. The value must be within the optical power range that is specified for the card. (Refer to the “Hardware Specifications” appendix in the <i>Cisco ONS 15454 DWDM Reference Manual</i> .) For OPT-BST, OPT-BST-E, OPT-BST-L cards, this parameter applies to Port 1 (COM-RX), Port 2 (COM-TX) and Port 4 (OSC-TX), which are related to the Optical Safety mechanism at the DWDM Network layer. (See the “Network Reference” chapter in the <i>Cisco ONS 15454 DWDM Reference Manual</i> for more information.)	Numeric. Double-click the table cell, enter a value and press Enter .
Power Degrade High (dBm)	Does not apply to OPT-BST, OPT-BST-E, OPT-BST-L and OPT-PRE line parameters.	—
Power Degrade Low (dBm)	Does not apply to OPT-BST, OPT-BST-E, OPT-BST-L and OPT-PRE line parameters.	—

Table 11-10 OPT-PRE, OPT-BST, OPT-BST-E, and OPT-BST-L Card Optical Line Alarm Thresholds Settings (continued)

Parameter	Description	Options
Gain Degrade Low (dB)	Does not apply to OPT-BST, OPT-BST-E, OPT-BST-L and OPT-PRE line parameters.	—
Gain Degrade High (dB)	Does not apply to OPT-BST, OPT-BST-E, OPT-BST-L and OPT-PRE line parameters.	—

Step 5 Return to your originating procedure (NTP).

DLP-G206 Change Optical Amplifier Line Settings for OPT-PRE and OPT-BST Amplifiers

Purpose	This task changes the optical amplifier line settings for OPT-PRE, OPT-BST, OPT-BST-E, and OPT-BST-L amplifier cards.
Tools/Equipment	None
Prerequisite Procedures	DLP-G46 Log into CTC, page 2-25
Required/As Needed	As needed
Onsite/Remote	Onsite or remote
Security Level	Provisioning or higher

- Step 1** In node view (single-shelf mode) or shelf view (multishelf mode), double-click the OPT-PRE, OPT-BST, OPT-BST-E, or OPT-BST-L amplifier where you want to change the optical amplifier line settings.
- Step 2** Click the **Provisioning > Opt. Ampli. Line > Parameters** tabs.
- Step 3** Modify any of the settings described in [Table 11-11](#). The provisionable parameters are listed in the Options column in the table. In the Options column, the SONET (ANSI) option is followed by the SDH (ETSI) option.

Table 11-11 OPT-PRE, OPT-BST, OPT-BST-E, and OPT-BST-L Optical Amplifier Line Settings

Parameter	Description	Options
Port	(Display only) Displays the port number, port type, and direction (TX or RX): OPT-PRE <ul style="list-style-type: none"> • 2 (COM-TX) OPT-BST, OPT-BST-E, OPT-BST-L <ul style="list-style-type: none"> • 6 (LINE-TX) 	—
Port Name	Provides the ability to assign the specified port a name.	User-defined. Name can be up to 32 alphanumeric/special characters. Blank by default. See the “ DLP-G104 Assign a Name to a Port ” task on page 7-3.
Admin State	Sets the port service state unless network conditions prevent the change. For more information about administrative states, refer to the “Administrative and Service States” appendix in the <i>Cisco ONS 15454 DWDM Reference Manual</i> .	From the drop-down list, choose one of the following: <ul style="list-style-type: none"> • IS,AINS/Unlocked,automaticInService • OOS,DSBLD/Locked,disabled • OOS,MT/Locked,maintenance
Service State	(Display only) Identifies the autonomously generated state that gives the overall condition of the port. Service states appear in the format: Primary State-Primary State Qualifier, Secondary State. For more information about service states, refer to the “Administrative and Service States” appendix in the <i>Cisco ONS 15454 DWDM Reference Manual</i> .	<ul style="list-style-type: none"> • IS-NR/Unlocked-enabled • OOS-AU,AINS/Unlocked-disabled, automaticInService • OOS-MA,DSBLD/Locked-enabled,disabled • OOS-MA,MT/Locked-enabled,maintenance
Line Direction	Shows the line direction associated with the optical signal that passes through the port. This parameter is automatically configured during ANS. To change it, you must modify the network plan in Cisco MetroPlanner, import the NE Update file and run ANS.	<ul style="list-style-type: none"> • East to West • West to East The options cannot be modified.
Total Output Power	(Display only) Shows the current power level per port.	—
Channel Power Ref.	(Display only) Shows the optical per-channel signal power setpoint that must be reached at the amplifier output when gain control is active.	Numeric. Double-click the table cell, enter a value, then press Enter .
Offset	Adjusts the Total Output Power unless network conditions prevent the adjustment, for example the port is in IS state.	Numeric. Double-click the table cell, enter a value, then press Enter .
Signal Output Power	(Display only) Shows the current output power leaving the amplifier, including the amplified spontaneous emissions (ASE) contribution.	—
Output Power Set-Point	(Display only) Shows the output power setpoint.	—

Table 11-11 OPT-PRE, OPT-BST, OPT-BST-E, and OPT-BST-L Optical Amplifier Line Settings (continued)

Parameter	Description	Options
Working Mode	(Display only) Shows the working mode, either GAIN or POWER.	—
Gain	(Display only) The current gain of the amplifiers.	—
Gain Set Point	The value of the gain that the amplifier must achieve. APC can modify this value based on the number of optical channel network connection (OCHNC) circuits that are managed by the amplifier or to compensate for fiber aging insertion loss. Refer to the “Network Reference” chapter in the <i>Cisco ONS 15454 DWDM Reference Manual</i> for more information.	Display only or numeric depending on mode setting. When the system is configured as metro core, this field is display only. When the system is configured as metro access, this field can be changed by the user.
AINS Soak	(Display only) Shows the automatic in-service soak period. It is always 00.00.	—
Tilt Reference	(Display only) Shows the default value for the amplifier tilt. This field can only be modified by ANS.	—
Tilt Calibration	Allows you to manually change the amplifier tilt.	Numeric. Double-click the parameter, enter a value, and press Enter .
DCU Insertion Loss	(OPT-PRE cards only; display only)	—

Step 4 Click **Apply**. If the change affects traffic, a warning message displays. Click **Yes** to complete the change.

Step 5 Return to your originating procedure (NTP).

DLP-G207 Change Optical Amplifier Threshold Settings for OPT-PRE and OPT-BST Amplifiers

Purpose	This task changes the optical channel threshold settings for the OPT-PRE, OPT-BST, OPT-BST-E, and OPT-BST-L amplifier cards.
Tools/Equipment	None
Prerequisite Procedures	DLP-G46 Log into CTC, page 2-25
Required/As Needed	As needed
Onsite/Remote	Onsite or remote
Security Level	Provisioning or higher



Caution

Warning thresholds are not monitored by CTC. They must be user-provisioned and monitored through custom alarm profiles.

- Step 1** In node view (single-shelf mode) or shelf view (multishelf mode), double-click the OPT-PRE, OPT-BST, OPT-BST-E, or OPT-BST-L amplifier where you want to change the optical channel threshold settings.
- Step 2** Click the **Provisioning > Opt Apli Line > Optics Thresholds** tabs.
- Step 3** If you want to change the warning thresholds, complete the following steps. If not, continue with [Step 4](#).
- Under Types, choose **Warning**.
 - Choose the warning interval that you want to provision, either **15 minutes** or **1 Day**.
 - Click **Refresh**.
 - Modify any of the warning thresholds shown under the Options column in [Table 11-12](#).
 - Click **Apply**. If the change affects traffic, a warning message displays. Click **Yes** to complete the change.

Table 11-12 *OPT-PRE, OPT-BST, OPT-BST-E, and OPT-BST-L Card Amplifier Line Warning Threshold Settings*

Parameter	Description	Options
Port	(Display only) Displays the port number, port type, and direction (TX or RX): OPT-PRE <ul style="list-style-type: none"> • 2 (COM-TX) OPT-BST, OPT-BST-E, OPT-BST-L <ul style="list-style-type: none"> • 6 (LINE-TX) 	—
opwrMin (dBm)	Sets the low power warning level.	Numeric. Can be set for 15-minute or one-day intervals. The default is -50 dBm. Double-click the parameter, enter a value, and press Enter .
opwrMax (dBm)	Sets the high power warning level.	Numeric. Can be set for 15-minute or one-day intervals. The default is 30 dBm. Double-click the parameter, enter a value, and press Enter .

- Step 4** If you want to change the alarm thresholds, complete the following steps. If not, continue with [Step 5](#).
- Choose the alarm interval that you want to provision, either **15 minutes** or **1 Day**.
 - Under Types, choose **Alarm**.
 - Click **Refresh**.
 - Modify any of the alarm thresholds shown under the Options column in [Table 11-13](#).
 - Click **Apply**. If the change affects traffic, a warning message displays. Click **Yes** to complete the change.

Table 11-13 *OPT-PRE, OPT-BST, OPT-BST-E, and OPT-BST-L Card Amplifier Line Alarm Thresholds Setting*

Parameter	Description	Options
Port	(Display only) Displays the port number, port type, and direction (TX or RX): OPT-PRE <ul style="list-style-type: none"> • 2 (COM-TX) OPT-BST, OPT-BST-E, OPT-BST-L <ul style="list-style-type: none"> • 6 (LINE-TX) 	—
Power Failure Low (dBm)	Shows the optical power failure low threshold for the port. The threshold is calculated automatically when you run ANS. You can manually change the threshold. The value must be within the optical power range that is specified for the card. (Refer to the “Hardware Specifications” appendix in the <i>Cisco ONS 15454 DWDM Reference Manual</i> .)	Numeric.
Power Degrade High (dBm)	Does not apply to OPT-PRE, OPT-BST, OPT-BST-E, or OPT-BST-L line parameters.	—
Power Degrade Low (dBm)	Does not apply to OPT-PRE, OPT-BST, OPT-BST-E, or OPT-BST-L line parameters.	—

Table 11-13 *OPT-PRE, OPT-BST, OPT-BST-E, and OPT-BST-L Card Amplifier Line Alarm Thresholds Setting (continued)*

Parameter	Description	Options
Gain Degradate High (dBm)	<p>(Display only) Shows the current value of the gain degrade high threshold configured in the card. This threshold applies only when the amplifier is active and in constant gain mode.</p> <p>Gain Degradate High refers to the port's Gain value and is automatically calculated by the TCC2/TCC2P and when the amplifier is turned up.</p> <p>The Gain Degradate High threshold is linked to the Gain setpoint. Changing the setpoint changes the Gain Degradate High threshold. The threshold value is always 2 dB higher than the Gain Setpoint value.</p> <p>APC can modify this value based on the number of OCHNC circuits that the amplifier is managing and to compensate for insertion loss due to fiber aging.</p>	—
Gain Degradate Low (dBm)	<p>(Display only) Shows the current value of the gain degrade low threshold configured in the card. This threshold applies only when the amplifier is active and in constant gain mode.</p> <p>Gain Degradate Low refers to the port's Gain value and is automatically calculated by the TCC2/TCC2P and when the amplifier is turned up.</p> <p>The Gain Degradate Low threshold is automatically linked to the Gain Setpoint that is provisioned. Changing the setpoint changes the Gain Degradate Low threshold. The threshold value is always 2 dB lower than the Gain Setpoint value.</p> <p>APC can also modify this value based on the number of OCHNC circuits that the amplifier is managing.</p>	—

Step 5 Return to your originating procedure (NTP).

DLP-G322 Change the OPT-BST ALS Maintenance Settings

Purpose	This task changes the ALS maintenance settings for the OPT-BST, OPT-BST-E, and OPT-BST-L cards.
Tools/Equipment	None
Prerequisite Procedures	DLP-G46 Log into CTC, page 2-25
Required/As Needed	As needed
Onsite/Remote	Onsite or remote
Security Level	Provisioning or higher



Note

The automatic laser shutdown (ALS) function should only be disabled temporarily for installation or maintenance reasons. Activate ALS immediately after maintenance or installation.



Warning

Invisible laser radiation could be emitted from the end of the unterminated fiber cable or connector. Do not stare into the beam directly with optical instruments. Viewing the laser output with certain optical instruments (for example, eye loupes, magnifiers, and microscopes) within a distance of 100 mm could pose an eye hazard. Statement 1056

- Step 1** In node view (single-shelf mode) or shelf view (multishelf mode), double-click the OPT-BST, OPT-BST-E, or OPT-BST-L where you want to change the ALS maintenance settings.
- Step 2** Click the **Maintenance > ALS** tabs.
- Step 3** Modify any of the settings described in [Table 11-14](#). The provisionable parameters are listed in the Options column in the table.

Table 11-14 OPT-BST Maintenance Settings

Parameter	Description	Options
OSRI	Optical safety remote interlock. When set to On, the OPT-BST TX output power is shut down.	From the drop-down list, choose one of the following: <ul style="list-style-type: none"> On Off
ALS Mode	Automatic laser shutdown. For OPT-BST cards, ALS provides the ability to shut down the OPT-BST TX laser when the OPT-BST RX detects an LOS. ALS also enables an optical safety mechanism at the DWDM network layer. See the “Automatic Laser Shutdown” section in the Card Reference chapter of the ONS 15454 DWDM Reference manual for more information.	From the drop-down list, choose one of the following: <ul style="list-style-type: none"> Disable—Deactivates ALS. Auto Restart—(Default) ALS is active. The power is automatically shut down when needed and automatically tries to restart using a probe pulse until the cause of the failure is repaired. Manual Restart Manual Restart for Test

Table 11-14 OPT-BST Maintenance Settings (continued)

Parameter	Description	Options
Recovery Pulse Duration	(Display only) Displays the duration of the optical power pulse that begins when an amplifier restarts.	—
Recovery Pulse Interval	(Display only) Displays the interval between optical power pulses.	—
Currently Shutdown	(Display only) Displays whether or not the laser is currently shut down, either YES or NO.	—
Request Laser Restart	If checked, allows you to restart the laser.	Checked or unchecked

Step 4 Click **Apply**. If the change affects traffic, a warning message displays. Click **Yes** to complete the change.

Step 5 Return to your originating procedure (NTP).

NTP-G160 Modify OPT-AMP-L Card Line Settings and PM Thresholds

Purpose	This procedure changes the line and threshold settings for the OPT-AMP-L amplifier card.
Tools/Equipment	None
Prerequisite Procedures	NTP-G30 Install the DWDM Cards, page 3-44
Required/As Needed	As needed
Onsite/Remote	Onsite or remote
Security Level	Provisioning or higher

Step 1 Complete the “[DLP-G46 Log into CTC](#)” task on page 2-25 at the node where you want to change the OPT-AMP-L amplifier card settings. If you are already logged in, proceed to [Step 2](#).

Step 2 Complete the “[NTP-G103 Back Up the Database](#)” procedure on page 13-2.

Step 3 Set the card working mode:



Caution

Do not change the OPT-AMP-L working mode if it is in service and circuits are provisioned.

- a. Display the OPT-AMP-L in card view.
- b. Click the **Provisioning > Card** tabs.
- c. In the Card Working Mode field, choose one of the following:
 - **OPT-PRE**—Sets the card working mode to optical preamplifier.
 - **OPT-LINE**—Sets the card working mode to optical booster.

d. Click **Apply**.

Step 4 Perform any of the following tasks as needed:

- [DLP-G323 Change Optical Line Settings for OPT-AMP-L Amplifiers, page 11-26](#)
- [DLP-G324 Change Optical Line Threshold Settings for OPT-AMP-L Amplifiers, page 11-28](#)
- [DLP-G325 Change Optical Amplifier Line Settings for OPT-AMP-L Amplifiers, page 11-30](#)
- [DLP-G326 Change Optical Amplifier Threshold Settings for OPT-AMP-L Amplifiers, page 11-32](#)
- [DLP-G327 Change the ALS Maintenance Settings of an OPT-AMP-L Card Configured in OPT-LINE Mode, page 11-36](#)

Step 5 Complete the “[NTP-G103 Back Up the Database](#)” procedure on page 13-2.

Stop. You have completed this procedure.

DLP-G323 Change Optical Line Settings for OPT-AMP-L Amplifiers

Purpose	This task changes the optical line settings for the OPT-AMP-L amplifier card.
Tools/Equipment	None
Prerequisite Procedures	DLP-G46 Log into CTC, page 2-25
Required/As Needed	As needed
Onsite/Remote	Onsite or remote
Security Level	Provisioning or higher

Step 1 In node view (single-shelf mode) or shelf view (multishelf mode), double-click the OPT-AMP-L amplifier where you want to change the optical line settings.

Step 2 Click the **Provisioning > Optical Line > Parameters** tabs.

Step 3 Modify any of the settings described in [Table 11-15](#). The provisionable parameters are listed in the Options column in the table. In the Options column, the SONET (ANSI) option is followed by the SDH (ETSI) option.

Table 11-15 OPT-AMP-L Amplifier Optical Line Settings

Parameter	Description	Options
Port	(Display only) Displays the port number, port type, and direction (TX or RX): <ul style="list-style-type: none"> • 1 (COM-RX) • 2 (COM-TX) • 3 (OSC-RX) • 4 (OSC-TX) • 5 (LINE-RX) • 7 (DC-RX) • 9 (DC-TX) 	—
Port Name	Provides the ability to assign the specified port a name.	User-defined. Name can be up to 32 alphanumeric/special characters. Blank by default. Double-click, enter the name, and press Enter . See the “ DLP-G104 Assign a Name to a Port ” task on page 7-3.
Admin State	Sets the port service state unless network conditions prevent the change. For more information about administrative states, refer to the “Administrative and Service States” appendix in the <i>Cisco ONS 15454 DWDM Reference Manual</i> .	From the drop-down list, choose one of the following: <ul style="list-style-type: none"> • IS/Unlocked • IS,AINS/Unlocked,automaticInService • OOS,DSBLD/Locked,disabled • OOS,MT/Locked,maintenance
Service State	(Display only) Identifies the autonomously generated state that gives the overall condition of the port. Service states appear in the format: Primary State-Primary State Qualifier, Secondary State. For more information about service states, refer to the “Administrative and Service States” appendix in the <i>Cisco ONS 15454 DWDM Reference Manual</i> .	<ul style="list-style-type: none"> • IS-NR/Unlocked-enabled • OOS-AU,AINS/Unlocked-disabled,automaticInService • OOS-MA,DSBLD/Locked-enabled,disabled • OOS-MA,MT/Locked-enabled,maintenance
Line Direction	Shows the line direction associated with the optical signal that passes through the port. This parameter is automatically configured during ANS. To change it, you must modify the network plan in Cisco MetroPlanner, import the NE Update file and run ANS.	<ul style="list-style-type: none"> • East to West • West to East The options cannot be modified.
AINS Soak	(Display only) Shows the soak time.	—
Power	(Display only) Shows the current power level per port.	—

Step 4 Click **Apply**. If the change affects traffic, a warning message displays. Click **Yes** to complete the change.

Step 5 Return to your originating procedure (NTP).

DLP-G324 Change Optical Line Threshold Settings for OPT-AMP-L Amplifiers

Purpose	This task changes the optical line threshold settings for OPT-AMP-L amplifier card.
Tools/Equipment	None
Prerequisite Procedures	DLP-G46 Log into CTC, page 2-25
Required/As Needed	As needed
Onsite/Remote	Onsite or remote
Security Level	Provisioning or higher



Caution

Warning thresholds are not monitored by CTC. They must be user-provisioned and monitored through custom alarm profiles.

- Step 1** In node view (single-shelf mode) or shelf view (multishelf mode), double-click the OPT-AMP-L amplifier where you want to change the optical line threshold settings.
- Step 2** Click the **Provisioning > Optical Line > Optics Thresholds** tabs.
- Step 3** If you want to change the warning thresholds, complete the following steps. If not, continue with [Step 4](#).
- Under Types, choose **Warning**.
 - Choose the warning interval that you want to provision, either **15 minutes** or **1 Day**.
 - Click **Refresh**.
 - Modify any of the warning thresholds shown under the Options column in [Table 11-16](#).
 - Click **Apply**. If the change affects traffic, a warning message displays. Click **Yes** to complete the change.

Table 11-16 OPT-AMP-L Card Optical Line Warning Threshold Settings

Parameter	Description	Options
Port	(Display only) Displays the port number, port type, and direction (TX or RX): <ul style="list-style-type: none"> • 1 (COM-RX) • 2 (COM-TX) • 3 (OSC-RX) • 4 (OSC-TX) • 5 (LINE-RX) • 7 (DC-RX) • 8 (DC-TX) 	—

Table 11-16 OPT-AMP-L Card Optical Line Warning Threshold Settings

Parameter	Description	Options
opwrMin (dBm)	Sets the low power warning level.	Numeric. Can be set for 15-minute or one-day intervals. The default is -50 dBm. Double-click, enter the name, and press Enter .
opwrMax (dBm)	Sets the high power warning level.	Numeric. Can be set for 15-minute or one-day intervals. The default is 30 dBm. Double-click, enter the name, and press Enter .

- Step 4** If you want to change the alarm thresholds, complete the following steps. If not, continue with [Step 5](#).
- Under Types, choose **Alarm**.
 - Click **Refresh**.
 - Modify any of the alarm thresholds shown under the Options column in [Table 11-17](#).
 - Click **Apply**. If the change affects traffic, a warning message displays. Click **Yes** to complete the change.

Table 11-17 OPT-AMP-L Card Optical Line Alarm Thresholds Setting

Parameter	Description	Options
Port	(Display only) Displays the port number. <ul style="list-style-type: none"> 1 (COM-RX) 2 (COM-TX) 3 (OSC-RX) 4 (OSC-TX) 5 (LINE-RX) 7 (DC-RX) 8 (DC-TX) 	—
Power Failure Low (dBm)	Shows the optical power failure low threshold for the port. The threshold is calculated automatically when you run ANS. You can manually change the threshold. The value must be within the optical power range that is specified for the card. (Refer to the “Hardware Specifications” appendix in the <i>Cisco ONS 15454 DWDM Reference Manual</i> .)	Numeric.
Power Degrade High (dBm)	Does not apply to OPT-AMP-L line parameters.	Numeric.
Power Degrade Low (dBm)	Does not apply to OPT-AMP-L line parameters.	Numeric.

Table 11-17 OPT-AMP-L Card Optical Line Alarm Thresholds Setting (continued)

Parameter	Description	Options
Gain Degrade Low (dBm)	Does not apply to OPT-AMP-L line parameters.	—
Gain Degrade High (dBm)	Does not apply to OPT-AMP-L line parameters.	—

Step 5 Return to your originating procedure (NTP).

DLP-G325 Change Optical Amplifier Line Settings for OPT-AMP-L Amplifiers

Purpose	This task changes the optical amplifier line settings for OPT-AMP-L amplifier card.
Tools/Equipment	None
Prerequisite Procedures	DLP-G46 Log into CTC, page 2-25
Required/As Needed	As needed
Onsite/Remote	Onsite or remote
Security Level	Provisioning or higher

- Step 1** In node view (single-shelf mode) or shelf view (multishelf mode), double-click the OPT-AMP-L amplifier where you want to change the optical amplifier line settings.
- Step 2** Click the **Provisioning > Opt. Ampli. Line > Parameters** tabs.
- Step 3** Modify any of the settings described in [Table 11-18](#). The provisionable parameters are listed in the Options column in the table. In the Options column, the SONET (ANSI) option is followed by the SDH (ETSI) option.

Table 11-18 OPT-AMP-L Optical Amplifier Line Settings

Parameter	Description	Options
Port	(Display only) Displays the port number, port type, and direction: 6 (LINE-TX).	—
Port Name	Provides the ability to assign the specified port a name.	User-defined. Name can be up to 32 alphanumeric/special characters. Blank by default. See the “ DLP-G104 Assign a Name to a Port ” task on page 7-3 .
Admin State	Sets the port service state unless network conditions prevent the change. For more information about administrative states, refer to the “Administrative and Service States” appendix in the <i>Cisco ONS 15454 DWDM Reference Manual</i> .	From the drop-down list, choose one of the following: <ul style="list-style-type: none"> IS/Unlocked IS,AINS/Unlocked,automaticInService OOS,DSBLD/Locked,disabled OOS,MT/Locked,maintenance

Table 11-18 OPT-AMP-L Optical Amplifier Line Settings (continued)

Parameter	Description	Options
Service State	(Display only) Identifies the autonomously generated state that gives the overall condition of the port. Service states appear in the format: Primary State-Primary State Qualifier, Secondary State. For more information about service states, refer to the “Administrative and Service States” appendix in the <i>Cisco ONS 15454 DWDM Reference Manual</i> .	<ul style="list-style-type: none"> IS-NR/Unlocked-enabled OOS-AU,AINS/Unlocked-disabled, automaticInService OOS-MA,DSBLD/Locked-enabled,disabled OOS-MA,MT/Locked-enabled,maintenance
Line Direction	Shows the line direction associated with the optical signal that passes through the port. This parameter is automatically configured during ANS. To change it, you must modify the network plan in Cisco MetroPlanner, import the NE Update file and run ANS.	<ul style="list-style-type: none"> East to West West to East <p>The options cannot be modified.</p>
Total Output Power	(Display only) Shows the current power level per port.	—
Channel Power Ref.	(Display only) Shows the optical per-channel signal power setpoint that must be reached at the amplifier output when gain control is active.	—
Offset	Adjusts the Total Output Power unless network conditions prevent the adjustment, for example the port is in IS state.	Numeric. Double-click to change.
Signal Output Power	(Display only) Shows the current output power leaving the amplifier, including the ASE contribution.	—
Output Power Set-Point	(Display only) Shows the output power setpoint.	—
Working Mode	(Display only) Shows the working mode, either Output Power or Control Gain	—
Gain	(Display only) The current gain of the amplifiers.	—
Gain Set Point	The value of the gain that the amplifier must achieve. APC can modify this value based on the number of OCHNC circuits that are managed by the amplifier or to compensate for fiber aging insertion loss. Refer to the “Network Reference” chapter in the <i>Cisco ONS 15454 DWDM Reference Manual</i> for more information.	Display only or numeric depending on mode setting. When the system is configured as metro core, this field is display only. When the system is configured as metro access, this field can be changed by the user.
AINS Soak	(Display only) Shows the automatic in-service soak period.	<ul style="list-style-type: none"> Duration of valid input signal, in hh.mm format, after which the card becomes in service (IS) automatically 0 to 48 hours, 15-minute increments
Tilt Reference	(Display only) Shows the default value for the amplifier tilt. This field can only be modified by ANS.	—

Table 11-18 OPT-AMP-L Optical Amplifier Line Settings (continued)

Parameter	Description	Options
Tilt Calibration	Allows you to manually change the amplifier tilt.	Numeric. Double-click the parameter, enter a value, and press Enter .
DCU Insertion Loss	(When provisioned as an OPT-PRE only; display only) Shows the DCU insertion loss.	—

Step 4 Click **Apply**. If the change affects traffic, a warning message displays. Click **Yes** to complete the change.

Step 5 Return to your originating procedure (NTP).

DLP-G326 Change Optical Amplifier Threshold Settings for OPT-AMP-L Amplifiers

Purpose	This task changes the optical channel threshold settings for the OPT-AMP-L amplifier card.
Tools/Equipment	None
Prerequisite Procedures	DLP-G46 Log into CTC, page 2-25
Required/As Needed	As needed
Onsite/Remote	Onsite or remote
Security Level	Provisioning or higher



Caution

Warning thresholds are not monitored by CTC. They must be user-provisioned and monitored through custom alarm profiles.

- Step 1** In node view (single-shelf mode) or shelf view (multishelf mode), double-click the OPT-AMP-L amplifier where you want to change the optical channel threshold settings.
- Step 2** Click the **Provisioning > Opt Ampli Line > Optics Thresholds** tabs.
- Step 3** If you want to change the warning thresholds, complete the following steps. If not, continue with [Step 4](#).
- Under Types, choose **Warning**.
 - Choose the warning interval that you want to provision, either **15 minutes** or **1 Day**.
 - Click **Refresh**.
 - Modify any of the warning thresholds shown under the Options column in [Table 11-19](#).
 - Click **Apply**. If the change affects traffic, a warning message displays. Click **Yes** to complete the change.

Table 11-19 OPT-AMP-L Card Amplifier Line Warning Threshold Settings

Parameter	Description	Options
Port	(Display only) Displays the port number, port type, and direction: 6 (LINE-TX).	—
opwrMin (dBm)	Sets the low power warning level.	Numeric. Can be set for 15-minute or one-day intervals. The default is -50 dBm. Double-click the parameter, enter a value, and press Enter .
opwrMax (dBm)	Sets the high power warning level.	Numeric. Can be set for 15-minute or one-day intervals. The default is 30 dBm. Double-click the parameter, enter a value, and press Enter .

- Step 4** If you want to change the alarm thresholds, complete the following steps. If not, continue with [Step 5](#).
- Under Types, choose **Alarm**.
 - Click **Refresh**.
 - Modify any of the alarm thresholds shown under the Options column in [Table 11-20](#).
 - Click **Apply**. If the change affects traffic, a warning message displays. Click **Yes** to complete the change.

Table 11-20 OPT-AMP-L Card Amplifier Line Alarm Thresholds Setting

Parameter	Description	Options
Port	(Display only) Displays the port number, port type, and direction: 6 (LINE-TX).	—
Power Failure Low (dBm)	Shows the optical power failure low threshold for the port. The threshold is calculated automatically when you run ANS. You can manually change the threshold. The value must be within the optical power range that is specified for the card. (Refer to the “Hardware Specifications” appendix in the <i>Cisco ONS 15454 DWDM Reference Manual</i> .)	Numeric. Double-click to change.

Table 11-20 OPT-AMP-L Card Amplifier Line Alarm Thresholds Setting (continued)

Parameter	Description	Options
Power Degrade High (dBm)	<p>(Display only) Shows the current value of the optical power degrade high threshold. This threshold applies only when the amplifier is active and in constant power mode.</p> <p>Power Degrade High refers to the port's Signal Output Power value and is automatically calculated by the TCC2/TCC2P when the amplifier is turned up.</p> <p>The Power Degrade High threshold is linked to the Output Power Setpoint on the Parameters tab. Changing the setpoint changes the Power Degrade High threshold. The threshold value is always 2 dB higher than the Output Power Setpoint value.</p> <p>APC can modify this value based on the number of OCHNC circuits that the amplifier is managing. Refer to the "Network Reference" chapter in the <i>Cisco ONS 15454 DWDM Reference Manual</i> for more information.</p>	—
Power Degrade Low (dBm)	<p>(Display only) Shows the current value of the optical power degrade high threshold configured in the card. This threshold applies only when the amplifier is active and in constant power mode.</p> <p>Power Degrade Low refers to the port's Signal Output Power value and is automatically calculated by the TCC2/TCC2P when the amplifier is turned up.</p> <p>The Power Degrade Low threshold is automatically linked to the Output Power Setpoint on the Parameters tab. Changing the setpoint changes the Power Degrade Low threshold. The threshold value is always 2 dB lower than the Output Power Setpoint.</p> <p>APC can modify this value based on the number of OCHNC circuits that the amplifier is managing.</p>	—

Table 11-20 OPT-AMP-L Card Amplifier Line Alarm Thresholds Setting (continued)

Parameter	Description	Options
Gain Degradate High (dBm)	<p>(Display only) Shows the current value of the gain degrade high threshold configured in the card. This threshold applies only when the amplifier is active and in constant gain mode.</p> <p>Gain Degradate High refers to the port's Gain value and is automatically calculated by the TCC2/TCC2P and when the amplifier is turned up.</p> <p>The Gain Degradate High threshold is linked to the Gain setpoint. Changing the setpoint changes the Gain Degradate High threshold. The threshold value is always 2 dB higher than the Gain Setpoint value.</p> <p>APC can modify this value based on the number of OCHNC circuits that the amplifier is managing and to compensate for insertion loss due to fiber aging.</p>	—
Gain Degradate Low (dBm)	<p>(Display only) Shows the current value of the gain degrade low threshold configured in the card. This threshold applies only when the amplifier is active and in constant gain mode.</p> <p>Gain Degradate Low refers to the port's Gain value and is automatically calculated by the TCC2/TCC2P and when the amplifier is turned up.</p> <p>The Gain Degradate Low threshold is automatically linked to the Gain Setpoint that is provisioned. Changing the setpoint changes the Gain Degradate Low threshold. The threshold value is always 2 dB lower than the Gain Setpoint value.</p> <p>APC can also modify this value based on the number of OCHNC circuits that the amplifier is managing.</p>	—

Step 5 Return to your originating procedure (NTP).

DLP-G327 Change the ALS Maintenance Settings of an OPT-AMP-L Card Configured in OPT-LINE Mode

Purpose	This task changes the ALS maintenance settings for the OPT-AMP-L card that is configured in OPT-LINE mode.
Tools/Equipment	None
Prerequisite Procedures	DLP-G46 Log into CTC, page 2-25
Required/As Needed	As needed
Onsite/Remote	Onsite or remote
Security Level	Provisioning or higher



Note

To perform this task, the OPT-AMP-L card must be in OPT-LINE mode. To change the OPT-AMP-L card mode, see the [“DLP-G323 Change Optical Line Settings for OPT-AMP-L Amplifiers”](#) task on [page 11-26](#).



Note

The automatic laser shutdown (ALS) function should only be disabled temporarily for installation or maintenance reasons. Activate ALS immediately after maintenance or installation.



Warning

Invisible laser radiation could be emitted from the end of the unterminated fiber cable or connector. Do not stare into the beam directly with optical instruments. Viewing the laser output with certain optical instruments (for example, eye loupes, magnifiers, and microscopes) within a distance of 100 mm could pose an eye hazard. Statement 1056

- Step 1** In node view (single-shelf mode) or shelf view (multishelf mode), double-click the OPT-AMP-L where you want to change the ALS maintenance settings.
- Step 2** Click the **Maintenance > ALS** tabs.
- Step 3** Modify any of the settings described in [Table 11-21](#). The provisionable parameters are listed in the Options column in the table.

Table 11-21 OPT-AMP-L Maintenance Settings

Parameter	Description	Options
OSRI	Optical safety remote interlock. When set to On, the OPT-AMP-L TX output power is shut down.	From the drop-down list, choose one of the following: <ul style="list-style-type: none"> On Off
ALS Mode	Automatic laser shutdown. For OPT-AMP-L cards, ALS provides the ability to shut down the OPT-AMP-L TX laser when the OPT-AMP-L RX detects an LOS. ALS also enables an optical safety mechanism at the DWDM network layer. See the “Network Reference” chapter in the <i>ONS 15454 DWDM Reference Manual</i> for more information.	From the drop-down list, choose one of the following: <ul style="list-style-type: none"> Disable—Deactivates ALS. Auto Restart—(Default) ALS is active. The power is automatically shut down when needed and automatically tries to restart using a probe pulse until the cause of the failure is repaired. Manual Restart Manual Restart for Test
Recovery Pulse Duration	(Display only) Displays the duration of the optical power pulse that begins when an amplifier restarts.	—
Recovery Pulse Interval	(Display only) Displays the interval between optical power pulses.	—
Currently Shutdown	(Display only) Displays the current status of the laser.	—
Request Laser Restart	If checked, allows you to restart the laser for maintenance.	Checked or unchecked

Step 4 Click **Apply**. If the change affects traffic, a warning message displays. Click **Yes** to complete the change.

Step 5 Return to your originating procedure (NTP).

NTP-G92 Modify 32MUX-O, 32DMX-O, 32DMX, 32DMX-L, and 4MD Line Card Settings and PM Thresholds

Purpose	This procedure changes the line and PM parameter threshold settings for the multiplexer and demultiplexer cards. The cards included in this category are the 32MUX-O, 32DMX-O, 32DMX, 32DMX-L, and 4MD-xx.x cards.
Tools/Equipment	None
Prerequisite Procedures	NTP-G30 Install the DWDM Cards, page 3-44
Required/As Needed	As needed
Onsite/Remote	Onsite or remote
Security Level	Provisioning or higher

Note

Complete the “[DLP-G141 View Optical Power Statistics for 32MUX-O, 32WSS, 32WSS-L, 32DMX-O, 32DMX, and 32DMX-L Cards](#)” task on page 9-13 to view multiplexer and demultiplexer optical power statistics.

-
- Step 1** Complete the “[DLP-G46 Log into CTC](#)” task on page 2-25 at the node where you want to change the 32MUX-O, 32DMX-O, 32DMX, 32DMX-L, or 4MD-xx.x card settings. If you are already logged in, proceed to [Step 2](#).
- Step 2** Complete the “[NTP-G103 Back Up the Database](#)” procedure on page 13-2.
- Step 3** Perform any of the following tasks as needed:
- [DLP-G208 Change Optical Line Settings for Multiplexer and Demultiplexer Cards, page 11-39](#)
 - [DLP-G209 Change Optical Line Threshold Settings for Multiplexer and Demultiplexer Cards, page 11-41](#)
 - [DLP-G210 Change Optical Channel Settings for Multiplexer and Demultiplexer Cards, page 11-43](#)
 - [DLP-G211 Change Optical Channel Threshold Settings for Multiplexer and Demultiplexer Cards, page 11-45](#)
- Step 4** Complete the “[NTP-G103 Back Up the Database](#)” procedure on page 13-2.
- Stop. You have completed this procedure.**
-

DLP-G208 Change Optical Line Settings for Multiplexer and Demultiplexer Cards

Purpose	This task changes the optical line settings for 32MUX-O, 32DMX-O, 32DMX, 32DMX-L, and 4MD-xx.x multiplexer and demultiplexer cards.
Tools/Equipment	None
Prerequisite Procedures	DLP-G46 Log into CTC, page 2-25
Required/As Needed	As needed
Onsite/Remote	Onsite or remote
Security Level	Provisioning or higher

- Step 1** In node view (single-shelf mode) or shelf view (multishelf mode), double-click the multiplexer or demultiplexer card where you want to change the optical line settings.
- Step 2** Perform one of the following:
- For 32MUX-O, 32DMX-O, 32DMX, 32DMX-L cards, click the **Provisioning > Optical Line > Parameters** tabs.
 - For 4MD cards, click the **Provisioning > Optical Band > Parameters** tabs.
- Step 3** Modify any of the settings described in [Table 11-22](#). The provisionable parameters are listed in the Options column in the table. In the Options column, the SONET (ANSI) option is followed by the SDH (ETSI) option.

Table 11-22 Multiplexer and Demultiplexer Card Optical Line Settings

Parameter	Description	Options
Port	(Display only) Displays the port number, port type, and direction (TX or RX): 32DMX, 32DMX-O, 32DMX-L <ul style="list-style-type: none"> 33 (COM-RX) 32MUX-O <ul style="list-style-type: none"> 33 (COM-TX) 4MD <ul style="list-style-type: none"> 9 (COM-RX) and 10 (COM-TX) 	—
Port Name	Provides the ability to assign the specified port a name.	User-defined. Name can be up to 32 alphanumeric/special characters. Blank by default. Double-click, enter the name, and press Enter . See the “ DLP-G104 Assign a Name to a Port ” task on page 7-3 .
Admin State	Sets the port service state unless network conditions prevent the change. For more information about administrative states, refer to the “Administrative and Service States” appendix in the <i>Cisco ONS 15454 DWDM Reference Manual</i> .	From the drop-down list, choose one of the following: <ul style="list-style-type: none"> IS,AINS/Unlocked,automaticInService OOS,DSBLD/Locked,disabled OOS,MT/Locked,maintenance

Table 11-22 Multiplexer and Demultiplexer Card Optical Line Settings (continued)

Parameter	Description	Options
Service State	(Display only) Identifies the autonomously generated state that gives the overall condition of the port. Service states appear in the format: Primary State-Primary State Qualifier, Secondary State. For more information about service states, refer to the “Administrative and Service States” appendix in the <i>Cisco ONS 15454 DWDM Reference Manual</i> .	<ul style="list-style-type: none"> IS-NR/Unlocked-enabled OOS-AU,AINS/Unlocked-disabled, automaticInService OOS-MA,DSBLD/Locked-enabled,disabled OOS-MA,MT/Locked-enabled,maintenance
Line Direction	Shows the line direction associated with the optical signal that passes through the port. This parameter is automatically configured during ANS. To change it, you must modify the network plan in Cisco MetroPlanner, import the NE Update file and run ANS.	<ul style="list-style-type: none"> East to West West to East <p>The options cannot be modified.</p>
Power	(Display only) Shows the current power level per port.	—
AINS Soak	(Display only) Sets the automatic in-service soak period. The value is always 00.00.	—
VOA Mode	(32DMX and 32DMX-L only; display only) Shows the functional mode of the VOA, when present.	<ul style="list-style-type: none"> Constant Attenuation Constant Power
VOA Power Ref	(32DMX and 32DMX-L only; display only) Shows the optical power setpoint that must be reached when a VOA is present and VOA Mode is set to Constant Power. This parameter can only be modified by ANS.	—
VOA Power Calib	(32DMX and 32DMX-L only) Modifies the optical power value of the VOA when VOA Mode is set to Constant Power.	Numeric. Double-click the parameter, enter a value, and press Enter .
VOA ATTenuation Ref	(32DMX and 32DMX-L only; display only) Shows the VOA attenuation value when VOA Mode is set to Constant Attenuation. This parameter can only be modified by ANS.	—
VOA Attenuation Calib	(32DMX and 32DMX-L only) Modifies the attenuation value of the VOA when the VOA Mode is set to Constant Attenuation.	Numeric. Double-click the parameter, enter a value, and press Enter .

Step 4 Click **Apply**. If the change affects traffic, a warning message displays. Click **Yes** to complete the change.

Step 5 Return to your originating procedure (NTP).

DLP-G209 Change Optical Line Threshold Settings for Multiplexer and Demultiplexer Cards

Purpose	This task changes the optical line threshold settings for 32MUX-O, 32DMX-O, 32DMX, 32DMX-L, and 4MD-xx.x multiplexer and demultiplexer cards.
Tools/Equipment	None
Prerequisite Procedures	DLP-G46 Log into CTC, page 2-25
Required/As Needed	As needed
Onsite/Remote	Onsite or remote
Security Level	Provisioning or higher

- Step 1** In node view (single-shelf mode) or shelf view (multishelf mode), double-click the multiplexer or demultiplexer card where you want to change the optical line threshold settings.
- Step 2** Perform one of the following:
- For 32MUX-O, 32DMX-O, 32DMX, 32DMX-L cards, click the **Provisioning > Optical Line > Optics Thresholds** tabs.
 - For 4MD cards, click the **Provisioning > Optical Band > Optics Thresholds** tabs.
- Step 3** If you want to change the warning thresholds, complete the following steps. If not, continue with [Step 4](#).
- a. Under Types, choose **Warning**.
 - b. Choose the warning interval that you want to provision, either **15 minutes** or **1 Day**.
 - c. Click **Refresh**.
 - d. Modify any of the warning thresholds shown under the Options column in [Table 11-23](#).
 - e. Click **Apply**. If the change affects traffic, a warning message displays. Click **Yes** to complete the change.

Table 11-23 Multiplexer and Demultiplexer Card Optical Line Warning Threshold Settings

Parameter	Description	Options
Port	(Display only) Displays the port number, port type, and direction (TX or RX): 32DMX, 32DMX-O, 32DMX-L <ul style="list-style-type: none"> • 33 (COM-RX) 32MUX-O <ul style="list-style-type: none"> • 33 (COM-TX) 4MD <ul style="list-style-type: none"> • 9 (COM-RX) and 10 (COM-TX) 	—

Table 11-23 Multiplexer and Demultiplexer Card Optical Line Warning Threshold Settings

Parameter	Description	Options
opwrMin (dBm)	Sets the low power warning level.	Numeric. Can be set for 15-minute or one-day intervals. The default is -50 dBm. Double-click the parameter, enter a value, and press Enter .
opwrMax (dBm)	Sets the high power warning level.	Numeric. Can be set for 15-minute or one-day intervals. The default is 30 dBm. Double-click the parameter, enter a value, and press Enter .

**Caution**

Warning thresholds are not monitored by CTC. They must be user-provisioned and monitored through custom alarm profiles.

- Step 4** If you want to change the alarm thresholds, complete the following steps. If not, continue with [Step 5](#).
- Under Types, choose **Alarm**.
 - Click **Refresh**.
 - Modify any of the alarm thresholds shown under the Options column in [Table 11-24](#).
 - Click **Apply**. If the change affects traffic, a warning message displays. Click **Yes** to complete the change.

Table 11-24 Multiplexer and Demultiplexer Optical Line Alarm Threshold Settings

Parameter	Description	Options
Port	(Display only) Displays the port number, port type, and direction (TX or RX): 32DMX, 32DMX-O, 32DMX-L <ul style="list-style-type: none"> 33 (COM-RX) 32MUX-O <ul style="list-style-type: none"> 33 (COM-TX) 4MD <ul style="list-style-type: none"> 9 (COM-RX) and 10 (COM-TX) 	—
Power Failure Low (dBm)	Shows the optical power failure low threshold for the port. The threshold is calculated automatically when you run ANS. You can manually change the threshold. The value must be within the optical power range that is specified for the card. (Refer to the “Hardware Specifications” appendix in the <i>Cisco ONS 15454 DWDM Reference Manual</i> .)	Numeric. Double-click the parameter, enter a value, and press Enter .

Table 11-24 Multiplexer and Demultiplexer Optical Line Alarm Threshold Settings (continued)

Parameter	Description	Options
Power Degrade High (dBm)	Not applicable to 32MUX-O, 32DMX-O, 32DMX, 32DMX-L, and 4MD-xx.x cards.	—
Power Degrade Low (dBm)	Not applicable to 32MUX-O, 32DMX-O, 32DMX, 32DMX-L, and 4MD-xx.x cards.	—

Step 5 Return to your originating procedure (NTP).

DLP-G210 Change Optical Channel Settings for Multiplexer and Demultiplexer Cards

Purpose	This task changes the optical channel settings for 32MUX-O, 32DMX-O, 32DMX, 32DMX-L, and 4MD-xx.x multiplexer and demultiplexer cards.
Tools/Equipment	None
Prerequisite Procedures	DLP-G46 Log into CTC, page 2-25
Required/As Needed	As needed
Onsite/Remote	Onsite or remote
Security Level	Provisioning or higher

- Step 1** In node view (single-shelf mode) or shelf view (multishelf mode), double-click the multiplexer or demultiplexer card where you want to change the optical channel settings.
- Step 2** Click the **Provisioning > Optical Chn > Parameters** tabs.
- Step 3** Modify any of the settings described in [Table 11-25](#). The provisionable parameters are listed in the Options column in the table. In the Options column, the SONET (ANSI) option is followed by the SDH (ETSI) option.

Table 11-25 Multiplexer and Demultiplexer Card Optical Channel Settings

Parameter	Description	Options
Port	(Display only) Displays the port number, port type, and direction (TX or RX): 32MUX-O, 32DMX-O, 32DMX, 32DMX-L 1 through 32 (CHAN-RX or CHAN-TX) 4MD-xx.x 1 through 8 (CHAN-RX or CHAN-TX)	—
Port Name	Provides the ability to assign the specified port a name.	User-defined. Name can be up to 32 alphanumeric/special characters. Blank by default. Double-click, enter the name, and press Enter . See the “ DLP-G104 Assign a Name to a Port ” task on page 7-3 .

Table 11-25 Multiplexer and Demultiplexer Card Optical Channel Settings (continued)

Parameter	Description	Options
Admin State	Sets the port service state unless network conditions prevent the change. For more information about administrative states, refer to the “Administrative and Service States” appendix in the <i>Cisco ONS 15454 DWDM Reference Manual</i> .	From the drop-down list, choose one of the following: <ul style="list-style-type: none"> IS,AINS/Unlocked,automaticInService OOS,DSBLD/Locked,disabled OOS,MT/Locked,maintenance
Service State	(Display only) Identifies the autonomously generated state that gives the overall condition of the port. Service states appear in the format: Primary State-Primary State Qualifier, Secondary State. For more information about service states, refer to the “Administrative and Service States” appendix in the <i>Cisco ONS 15454 DWDM Reference Manual</i> .	<ul style="list-style-type: none"> IS-NR/Unlocked-enabled OOS-AU,AINS/Unlocked-disabled, automaticInService OOS-MA,DSBLD/Locked-enabled,disabled OOS-MA,MT/Locked-enabled,maintenance
Line Direction	Shows the line direction associated with the optical signal that passes through the port. This parameter is automatically configured during ANS. To change it, you must modify the network plan in Cisco MetroPlanner, import the NE Update file and run ANS.	<ul style="list-style-type: none"> East to West West to East <p>The options cannot be modified.</p>
Power	(Display only) Shows the current power level per port.	—
Actual Wavelength	(Display only) Shows the wavelength specified by the manufacturing data. This field cannot be set manually.	—
Expected Wavelength	(Display only) Shows the preprovisioned wavelength. This field is used to preprovision cards.	—
AINS Soak	(Display only) Automatic in-service soak period. It is always 00.00	—
VOA Mode	(Display only; 32MUX-O, 32DMX-0, 4MD-xx.x cards only) Shows the current functional mode of the VOA.	<ul style="list-style-type: none"> Constant Power Constant Attenuation
VOA Power Ref.	(Display only; 32MUX-O, 32DMX-0, 4MD-xx.x cards only) Shows the Power setpoint that must be reached on the path where a VOA is present when the VOA Mode is Constant Power. Demultiplexers show the reference value of the desired optical power going to the client. Multiplexers show the reference value of the desired per-channel optical power. This parameter can only be modified by ANS.	—

Table 11-25 Multiplexer and Demultiplexer Card Optical Channel Settings (continued)

Parameter	Description	Options
VOA Power Calib.	(32MUX-O, 32DMX-0, 4MD-xx.x cards only) The user can modify the optical output power to the VOA if necessary. The VOA power calibration offsets the VOA power reference. For demultiplexers, you can modify the optical output power to the client if necessary. For multiplexers, you can modify the output power per channel. This feature is normally used when the Network Type is configured as Access in the Provisioning > WDM-ANS tab.	Numeric. Double-click the parameter, enter a value and press Enter .
VOA Attenuation Ref.	(Display only; 32MUX-O, 32DMX-0, 4MD-xx.x cards only) Shows the attenuation value of the VOA when the VOA is set in attenuation mode. This parameter can only be modified by ANS and APC.	—
VOA Attenuation Calib.	(32MUX-O, 32DMX-0, and 4MD-xx.x cards only) Allows the user to modify the attenuation value of the VOA if necessary when the VOA mode is set for constant attenuation.	Numeric, double-click the parameter, enter a value and press Enter .

Step 4 Click **Apply**. If the change affects traffic, a warning message displays. Click **Yes** to complete the change.

Step 5 Return to your originating procedure (NTP).

DLP-G211 Change Optical Channel Threshold Settings for Multiplexer and Demultiplexer Cards

Purpose	This task changes the optical channel threshold settings for 32MUX-O, 32DMX-O, 32DMX, 32DMX-L, and 4MD-xx.x multiplexer and demultiplexer cards.
Tools/Equipment	None
Prerequisite Procedures	DLP-G46 Log into CTC, page 2-25
Required/As Needed	As needed
Onsite/Remote	Onsite or remote
Security Level	Provisioning or higher



Caution

Warning thresholds are not monitored by CTC. They must be user-provisioned and monitored through custom alarm profiles.

Step 1 In node view (single-shelf mode) or shelf view (multishelf mode), double-click the multiplexer or demultiplexer card where you want to change the optical threshold settings.

- Step 2** Click the **Provisioning > Optical Chn > Optics Thresholds** tabs.
- Step 3** If you want to change the warning thresholds, complete the following steps. If not, continue with [Step 4](#).
- Under Types, choose **Warning**.
 - Choose the warning interval that you want to provision, either **15 minutes** or **1 Day**.
 - Click **Refresh**.
 - Modify any of the warning thresholds shown under the Options column in [Table 11-26](#).
 - Click **Apply**. If the change affects traffic, a warning message displays. Click **Yes** to complete the change.

Table 11-26 Multiplexer and Demultiplexer Card Optical Channel Warning Threshold Settings

Parameter	Description	Options
Port	(Display only) Displays the port number, port type, and direction (TX or RX): 32MUX-O, 32DMX-O, 32DMX, 32DMX-L <ul style="list-style-type: none"> 1 through 32 (CHAN-RX or CHAN-TX) 4MD-xx.x <ul style="list-style-type: none"> 1 through 8 (CHAN-RX or CHAN-TX) 	—
opwrMin (dBm)	Set the low power warning level.	Numeric. Can be set for 15-minute or one-day intervals. The default is -50 dBm. Double-click the parameter, enter a value, and press Enter .
opwrMax (dBm)	Set the high power warning level.	Numeric. Can be set for 15-minute or one-day intervals. The default is 30 dBm. Double-click the parameter, enter a value, and press Enter .

- Step 4** If you want to change the alarm thresholds, complete the following steps. If not, continue with [Step 5](#).
- Under Types, choose **Alarm**.
 - Click **Refresh**.
 - Modify any of the alarm thresholds shown under the Options column in [Table 11-27](#).
 - Click **Apply**. If the change affects traffic, a warning message displays. Click **Yes** to complete the change.

Table 11-27 Multiplexer and Demultiplexer Card Optical Channel Alarm Threshold Settings

Parameter	Description	Options
Port	<p>(Display only) Displays the port number, port type, and direction (TX or RX):</p> <p>32MUX-O, 32DMX-O, 32DMX, 32DMX-L</p> <ul style="list-style-type: none"> 1 through 32 (CHAN-RX or CHAN-TX) <p>4MD-xx.x</p> <ul style="list-style-type: none"> 1 through 8 (CHAN-RX or CHAN-TX) 	—
Power Failure Low (dBm)	<p>Shows the power failure low threshold. This power value applies to the corresponding port and is automatically calculated when ANS is run.</p> <p>This threshold applies to a port associated to a VOA (OSC-VOA) always active in Constant Power mode.</p> <p>The threshold is automatically linked to the Power Setpoint (VOA Power Ref + VOA Power Calib) that is provisioned. Changing the setpoint results in changing the threshold (always 5 dB lower).</p> <p>The 32DMX is an exception. 32DMX Power Failure Low thresholds apply to ports that are not associated to a VOA. The threshold is calculated automatically when you run ANS. You can manually change the threshold. The value must be within the optical power range that is specified for the card. (Refer to the “Hardware Specifications” appendix in the <i>Cisco ONS 15454 DWDM Reference Manual</i>.)</p>	Numeric. Double-click the parameter, enter a value, and press Enter .

Table 11-27 Multiplexer and Demultiplexer Card Optical Channel Alarm Threshold Settings

Parameter	Description	Options
Power Degrade High (dBm)	Shows the power degrade high threshold. This power value applies to the corresponding port and is automatically calculated when ANS is run. This threshold applies to a port associated to a VOA (OSC-VOA) always active in Constant Power mode. The threshold is automatically linked to the Power Setpoint (VOA Power Ref + VOA Power Calib) that is provisioned. Changing the setpoint will result in changing the threshold (always 3 dB higher). This threshold does not apply to the 32DMX and 32DMX-L cards.	—
Power Degrade Low (dBm)	Shows the power degrade low threshold. This power value applies to the corresponding port and is automatically calculated when ANS is run. This threshold applies to a port associated to a VOA (OSC-VOA) always active in Constant Power mode. The threshold is automatically linked to the Power Setpoint (VOA Power Ref + VOA Power Calib) that is provisioned. Changing the setpoint will result in changing the threshold (always 2 dB lower). This threshold does not apply to the 32DMX and 32DMX-L cards.	Numeric. Double-click the parameter, enter a value, and press Enter .

Step 5 Return to your originating procedure (NTP).

NTP-G93 Modify the 32WSS and 32WSS-L Line Settings and PM Thresholds

Purpose This procedure changes the 32WSS and 32WSS-L card thresholds and settings.

Tools/Equipment None

Prerequisite Procedures [NTP-G30 Install the DWDM Cards, page 3-44](#).

Required/As Needed	As needed
Onsite/Remote	Onsite or remote
Security Level	Provisioning or higher

Step 1 Complete the “[DLP-G46 Log into CTC](#)” task on page 2-25 at the node where you want to change the 32WSS and 32WSS-L card settings. If you are already logged in, continue with Step 2.

Step 2 Complete the “[NTP-G103 Back Up the Database](#)” procedure on page 13-2.

Step 3 Perform any of the following tasks as needed:

- [DLP-G212 Change 32WSS and 32WSS-L Optical Channel Parameters](#), page 11-49
- [DLP-G213 Change the 32WSS and 32WSS-L Optical Channel Thresholds](#), page 11-52



Note To use the alarm profile tab, including creating alarm profiles and suppressing alarms, see [Chapter 8, “Manage Alarms.”](#)

- [DLP-G214 Change 32WSS and 32WSS-L Optical Line Parameters](#), page 11-55
- [DLP-G215 Change the 32WSS and 32-WSS-L Optical Line Thresholds](#), page 11-56

Step 4 Complete the “[NTP-G103 Back Up the Database](#)” procedure on page 13-2.

Stop. You have completed this procedure.

DLP-G212 Change 32WSS and 32WSS-L Optical Channel Parameters

Purpose	This task changes the optical channel parameter settings for the 32WSS and 32WSS-L cards.
Tools/Equipment	None
Prerequisite Procedures	DLP-G46 Log into CTC , page 2-25
Required/As Needed	As needed
Onsite/Remote	Onsite or remote
Security Level	Provisioning or higher

Step 1 In node view (single-shelf mode) or shelf view (multishelf mode), double-click the 32WSS and 32WSS-L card where you want to change the optical channel parameter settings.

Step 2 Click the **Provisioning > Optical Chn: Optical Connectors > Parameters** tabs, where n = one of the four available groups of eight optical channels.

Step 3 Modify any of the settings described in [Table 11-28](#). The provisionable parameters are listed in the Options column in the table. In the Options column, the SONET (ANSI) option is followed by the SDH (ETSI) option.

Table 11-28 32WSS and 32WSS-L Optical Channel Parameter Settings

Parameter	Description	Options
Port	(Display only) Shows the port number. Each optical channel (wavelength) has two logical ports. However, only one is active at a time depending on the operating mode provisioned for the port on the card view Maintenance tab: either CHAN-RX or PASS-THROUGH. Ports 1 through 32 (CHAN-RX) are assigned to optical channels configured as Add Channels. Ports 33 through 64 (PASS-THROUGH) are assigned to optical channels configured as pass-through channels.	—
Port Name	Allows a logical name to be assigned for each of the port.	User-defined. Name can be up to 32 alphanumeric/special characters. Blank by default. Double-click, enter the name, and press Enter . See the “ DLP-G104 Assign a Name to a Port ” task on page 7-3.
Admin State	Sets the port service state unless network conditions prevent the change. For more information about administrative states, refer to the “Administrative and Service States” appendix in the <i>Cisco ONS 15454 DWDM Reference Manual</i> .	From the drop-down list, choose one of the following: <ul style="list-style-type: none"> IS,AINS/Unlocked,automaticInService OOS,DSBLD/Locked,disabled OOS,MT/Locked,maintenance
Service State	(Display only) Identifies the autonomously generated state that gives the overall condition of the port. Service states appear in the format: Primary State-Primary State Qualifier, Secondary State. For more information about service states, refer to the “Administrative and Service States” appendix in the <i>Cisco ONS 15454 DWDM Reference Manual</i> .	<ul style="list-style-type: none"> IS-NR/Unlocked-enabled OOS-AU,AINS/Unlocked-disabled,automaticInService OOS-MA,DSBLD/Locked-enabled,disabled OOS-MA,MT/Locked-enabled,maintenance
Line Direction	Shows the line direction associated with the optical signal that passes through the port. This parameter is automatically configured during ANS. To change it, you must modify the network plan in Cisco MetroPlanner, import the NE Update file and run ANS.	<ul style="list-style-type: none"> East to West West to East The options cannot be modified.
Power	(Display only) Power value read by the photodiode located after the VOA associated to the port, and calibrated to the COM_TX port. For more information, see the “Card Reference” chapter or the “Hardware Specifications” appendix in the <i>Cisco ONS 15454 DWDM Reference Manual</i> .	Numeric value (dB)
Actual Wavelength	(Display only) Displays the actual wavelength utilized by the channel.	—

Table 11-28 32WSS and 32WSS-L Optical Channel Parameter Settings (continued)

Parameter	Description	Options
Expected Wavelength	(Display only) Displays the expected wavelength assigned for the channel.	—
AINS Soak	(Display only) Shows the automatic in-service soak period. It is always 00.00	—
VOA Mode	(Display only) Displays the active VOA working mode.	<ul style="list-style-type: none"> • Constant Power • Constant Attenuation
VOA Power Reference	(Display only) Shows the value of the optical power setpoint that must be reached on the path where a VOA is present, when VOA Mode is set to Constant Power. This value is the desired per-channel optical power. This parameter can only be modified by ANS.	Numeric value (dB)
VOA Power Calibration	Allows you to modify the VOA power value when VOA Mode is Constant Power.	Double-click the parameter, enter a value, and press Enter . <ul style="list-style-type: none"> • Numeric value (dB) • -37 dB to -2 dB
VOA Attenuation Reference	(Display only) Shows the attenuation value of the VOA when the VOA Mode is Constant Attenuation. This parameter can only be modified by ANS.	Numeric value (dB)
VOA Attenuation Calibration	Allows you to modify the VOA attenuation value when VOA Mode is Constant Attenuation.	Double-click the parameter, enter a value, and press Enter . <ul style="list-style-type: none"> • Numeric value (dB) • -30 dB to +30 dB
Power ADD	(Display only) Displays a measurement of the optical power coming in on the ADD RX port, reported in the CHAN-RX port column. This is the power transmitted by the TX laser of the TXP or MXP card that is connected to the 32WSS or 32WSS-L.	Numeric value (dB)
Path Value	(Display only) Displays Path value for the CHAN-RX port column parameter.	<ul style="list-style-type: none"> • Standby

Step 4 Click **Apply**. If the change affects traffic, a warning message displays. Click **Yes** to complete the change.

Step 5 Return to your originating procedure (NTP).

DLP-G213 Change the 32WSS and 32WSS-L Optical Channel Thresholds

Purpose	This task changes the optical channel threshold settings for the 32WSS and 32WSS-L cards.
Tools/Equipment	None
Prerequisite Procedures	DLP-G46 Log into CTC, page 2-25
Required/As Needed	As needed
Onsite/Remote	Onsite or remote
Security Level	Provisioning or higher



Caution

Warning thresholds are not monitored by CTC. They must be user-provisioned and monitored through custom alarm profiles.

- Step 1** In node view (single-shelf mode) or shelf view (multishelf mode), double-click the 32WSS or 32WSS-L card where you want to change the optical channel optics threshold settings.
- Step 2** Click the **Provisioning > Optical Chn: Optical Connectors > Optics Thresholds** tabs, where *n* = one of the four groups of eight optical channels that are available.
- Step 3** If you want to change the warning thresholds, complete the following steps. If not, continue with [Step 4](#).
- Under Types, choose **Warning**.
 - Choose the warning interval that you want to provision, either **15 minutes** or **1 Day**.
 - Click **Refresh**.
 - Modify any of the warning thresholds shown under the Options column in [Table 11-29](#).
 - Click **Apply**. If the change affects traffic, a warning message displays. Click **Yes** to complete the change.

Table 11-29 32WSS and 32WSS-L Optical Channel Warning Threshold Settings

Parameter	Description	Options
Port	(Display only) Shows the port number, port type, and direction (RX or TX). Each optical channel (wavelength) has two logical ports. However, only one is active at a time depending on the operating mode provisioned for the port on the card view Maintenance tab: either CHAN-RX or PASS-THROUGH.	—
opwrMin (dBm)	Set the low power warning level.	Numeric. Can be set for 15-minute or one-day intervals. Double-click the parameter, enter a value, and press Enter .
opwrMax (dBm)	Set the high power warning level.	Numeric. Can be set for 15-minute or one-day intervals. Double-click the parameter, enter a value, and press Enter .

- Step 4** If you want to change the alarm thresholds, complete the following steps. If not, continue with [Step 5](#).
- Under Types, choose **Alarm**.
 - Click **Refresh**.
 - Modify any of the alarm thresholds shown under the Options column in [Table 11-30](#).
 - Click **Apply**. If the change affects traffic, a warning message displays. Click **Yes** to complete the change.

Table 11-30 32WSS and 32WSS-L Optical Channel Alarm Threshold Settings

Parameter	Description	Options
Port	<p>(Display only) Displays the port number, port type, and direction (RX or TX). For each optical channel (wavelength), two logical ports are associated. Only one port can be active at a time, depending on the port's operating mode. The operating mode, provisioned on the card view Maintenance tab, is either CHAN RX or PASS-THROUGH.</p> <p>Ports 1 through 32 (CHAN-RX) are associated to optical channels configured as Add Drop channels. Ports 33 through 64 (PASS-THROUGH) are associated to optical channels configured as Pass-Through channels.</p>	—
Power Failure Low (dBm)	<p>Shows the power failure low threshold. This power value applies to the corresponding port and is automatically calculated when ANS is run.</p> <p>This threshold applies to a port associated to a VOA (OSC-VOA) always active in Constant Power mode.</p> <p>The threshold is automatically linked to the Power Setpoint (VOA Power Ref + VOA Power Calib) that is provisioned. Changing the setpoint results in changing the threshold (always 5 dB lower).</p> <p>The threshold is calculated automatically when you run ANS. (Refer to the "Hardware Specifications" appendix in the <i>Cisco ONS 15454 DWDM Reference Manual</i>.)</p>	Numeric. CTC does not allow it to be changed.

Table 11-30 32WSS and 32WSS-L Optical Channel Alarm Threshold Settings (continued)

Parameter	Description	Options
Power Degrade High (dBm)	<p>(Display only) Shows the power degrade high threshold. This power value applies to the corresponding port and is automatically calculated when ANS is run.</p> <p>This threshold applies to a port associated to a VOA (OSC-VOA) always active in Constant Power mode.</p> <p>The threshold is automatically linked to the Power Setpoint (VOA Power Ref + VOA Power Calib) that is provisioned. Changing the setpoint results in changing the threshold (always 3 dB higher).</p>	—
Power Degrade Low (dBm)	<p>(Display only) Shows the power degrade low threshold. This power value applies to the corresponding port and is automatically calculated when ANS is run.</p> <p>This threshold applies to a port associated to a VOA (OSC-VOA) always active in Constant Power mode.</p> <p>The threshold is automatically linked to the Power Setpoint (VOA Power Ref + VOA Power Calib) that is provisioned. Changing the setpoint results in changing the threshold (always 2 dB lower).</p>	Numeric
Power ADD Failure Low (dBm)	<p>Shows the power add failure low threshold. This power value applies to the corresponding port and is automatically calculated when ANS is run.</p> <p>This threshold applies to the actual measurement of the optical power on the ADD RX port, reported as CHAN RX, that is, the power transmitted by the Trunk-Tx laser of the TXP/MXP card connected to the 32WSS or 32WSS-L card.</p>	Numeric. CTC does not allow it to be changed.

Step 5 Return to your originating procedure (NTP).

DLP-G214 Change 32WSS and 32WSS-L Optical Line Parameters

Purpose	This task changes the optical line parameter settings for the 32WSS and 32WSS-L cards.
Tools/Equipment	None
Prerequisite Procedures	DLP-G46 Log into CTC, page 2-25
Required/As Needed	As needed
Onsite/Remote	Onsite or remote
Security Level	Provisioning or higher

- Step 1** In node view (single-shelf mode) or shelf view (multishelf mode), double-click the 32WSS or 32WSS-L card where you want to change the optical line parameter settings.
- Step 2** Click the **Provisioning > Optical Line > Parameters** tabs.
- Step 3** Modify any of the settings described in [Table 11-31](#). The provisionable parameters are listed in the Options column in the table. In the Options column, the SONET (ANSI) option is followed by the SDH (ETSI) option.

Table 11-31 32WSS and 32WSS-L Optical Line Parameter Settings

Parameter	Description	Options
Port	(Display only) Displays the port number, port type, and direction (RX or TX). <ul style="list-style-type: none"> 65 (EXP-TX) 66 (EXP-RX) 67 (COM-TX) 68 (COM-RX) 69 (DROP-TX) 	—
Port Name	Allows you to assign a logical name for each of the ports shown.	User-defined. Name can be up to 32 alphanumeric/special characters. Blank by default. Double-click, enter the name, and press Enter . See the “ DLP-G104 Assign a Name to a Port ” task on page 7-3 .
Admin State	Sets the port service state unless network conditions prevent the change. For more information about administrative states, refer to the “Administrative and Service States” appendix in the <i>Cisco ONS 15454 DWDM Reference Manual</i> .	From the drop-down list, choose one of the following: <ul style="list-style-type: none"> IS,AINS/Unlocked,automaticInService OOS,DSBLD/Locked,disabled OOS,MT/Locked,maintenance
Service State	(Display only) Identifies the autonomously generated state that gives the overall condition of the port. Service states appear in the format: Primary State-Primary State Qualifier, Secondary State. For more information about service states, refer to the “Administrative and Service States” appendix in the <i>Cisco ONS 15454 DWDM Reference Manual</i> .	<ul style="list-style-type: none"> IS-NR/Unlocked-enabled OOS-AU,AINS/Unlocked-disabled,automaticInService OOS-MA,DSBLD/Locked-enabled,disabled OOS-MA,MT/Locked-enabled,maintenance

Table 11-31 32WSS and 32WSS-L Optical Line Parameter Settings (continued)

Parameter	Description	Options
Line Direction	Shows the line direction associated with the optical signal that passes through the port. This parameter is automatically configured during ANS. To change it, you must modify the network plan in Cisco MetroPlanner, import the NE Update file and run ANS.	<ul style="list-style-type: none"> East to West West to East The options cannot be modified.
Power	(Display only) Power value read by the photodiode associated with the port.	Numeric value (dB)
AINS Soak	(Display only) The automatic in-service soak period. It is always 00.00.	—

Step 4 Return to your originating procedure (NTP).

DLP-G215 Change the 32WSS and 32-WSS-L Optical Line Thresholds

Purpose	This task changes the 32WSS and 32WSS-L card optical line threshold settings.
Tools/Equipment	None
Prerequisite Procedures	DLP-G46 Log into CTC, page 2-25
Required/As Needed	As needed
Onsite/Remote	Onsite or remote
Security Level	Provisioning or higher



Caution

Warning thresholds are not monitored by CTC. They must be user-provisioned and monitored through custom alarm profiles.

- Step 1** In node view (single-shelf mode) or shelf view (multishelf mode), double-click the 32WSS or 32WSS-L card where you want to change the optical line optics warning threshold settings.
- Step 2** Click the **Provisioning > Optical Line > Optics Thresholds** tabs for one of the four groups of eight optical channels that are available.
- Step 3** If you want to change the warning thresholds, complete the following steps. If not, continue with [Step 4](#).
- Under Types, choose **Warning**.
 - Choose the warning interval that you want to provision, either **15 minutes** or **1 Day**.
 - Click **Refresh**.
 - Modify any of the warning thresholds shown under the Options column in [Table 11-32](#).
 - Click **Apply**. If the change affects traffic, a warning message displays. Click **Yes** to complete the change.

Table 11-32 32WSS and 32WSS-L Optical Line Warning Threshold Settings

Parameter	Description	Options
Port	(Display only) Displays the port number, port type, and direction (RX or TX): <ul style="list-style-type: none"> • 65 (EXP-TX) • 66 (EXP-RX) • 67 (COM-TX) • 68 (COM-RX) • 69 (DROP-TX) 	—
opwrMin (dBm)	Set the low power warning level.	Numeric. Can be set for 15-minute or one-day intervals. The default is -50 dBm.
opwrMax (dBm)	Set the high power warning level.	Numeric. Can be set for 15-minute or one-day intervals. The default is 30 dBm.

- Step 4** If you want to change the alarm thresholds, complete the following steps. If not, continue with [Step 5](#).
- Under Types, choose **Alarm**.
 - Click **Refresh**.
 - Modify any of the alarm thresholds shown under the Options column in [Table 11-33](#).
 - Click **Apply**. If the change affects traffic, a warning message displays. Click **Yes** to complete the change.

Table 11-33 32WSS and 32WSS-L Optical Line Alarm Threshold Settings

Parameter	Description	Options
Port	(Display only) Displays the port number, port type, and direction (RX or TX): <ul style="list-style-type: none"> • 65 (EXP-TX) • 66 (EXP-RX) • 67 (COM-TX) • 68 (COM-RX) • 69 (DROP-TX) 	—
Power Failure Low (dBm)	Shows the power failure low threshold. This power value applies to the corresponding port and is automatically calculated when ANS is run. You can manually change the threshold. The value must be within the optical power range that is specified for the card. (Refer to the “Hardware Specifications” appendix in the <i>Cisco ONS 15454 DWDM Reference Manual</i> .)	Numeric. Double-click the parameter, enter a value, and press Enter .

Table 11-33 32WSS and 32WSS-L Optical Line Alarm Threshold Settings (continued)

Parameter	Description	Options
Power Degrade High (dBm)	Does not apply to 32WSS and 32WSS-L cards at the optical line level.	—
Power Degrade Low (dBm)	Does not apply to 32WSS and 32WSS-L cards at the optical line level.	—

Step 5 Return to your originating procedure (NTP).

NTP-G149 Modify the MMU Line Settings and PM Thresholds

Purpose	This procedure changes the MMU card thresholds and settings.
Tools/Equipment	None
Prerequisite Procedures	NTP-G30 Install the DWDM Cards, page 3-44 .
Required/As Needed	As needed
Onsite/Remote	Onsite or remote
Security Level	Provisioning or higher

Step 1 Complete the “[DLP-G46 Log into CTC](#)” task on page 2-25 at the node where you want to change the MMU card settings. If you are already logged in, continue with Step 2.

Step 2 Complete the “[NTP-G103 Back Up the Database](#)” procedure on page 13-2.

Step 3 Perform any of the following tasks as needed:



Note To use the alarm profile tab, including creating alarm profiles and suppressing alarms, see [Chapter 8, “Manage Alarms.”](#)

- [DLP-G342 Change MMU Optical Line Parameters, page 11-59](#)
- [DLP-G343 Change the MMU Optical Line Thresholds, page 11-60](#)

Step 4 Complete the “[NTP-G103 Back Up the Database](#)” procedure on page 13-2.

Stop. You have completed this procedure.

DLP-G342 Change MMU Optical Line Parameters

Purpose	This task changes the optical line parameter settings for the MMU card.
Tools/Equipment	None
Prerequisite Procedures	DLP-G46 Log into CTC, page 2-25
Required/As Needed	As needed
Onsite/Remote	Onsite or remote
Security Level	Provisioning or higher

- Step 1** In node view (single-shelf mode) or shelf view (multishelf mode), double-click the MMU card where you want to change the optical line parameter settings.
- Step 2** Click the **Provisioning > Optical Line > Parameters** tabs.
- Step 3** Modify any of the settings described in [Table 11-34](#). The provisionable parameters are listed in the Options column in the table. In the Options column, the SONET (ANSI) option is followed by the SDH (ETSI) option.

Table 11-34 MMU Optical Line Parameter Settings

Parameter	Description	Options
Port	(Display only) Displays the port number, port type, and direction (RX or TX): <ul style="list-style-type: none"> 1 (EXP-RX) 2 (EXP-TX) 3 (COM-RX) 4 (COM-TX) 5 (EXP A-RX) 6 (EXP A-TX) 	—
Port Name	Allows you to assign a logical name for each of the ports shown.	User-defined. Name can be up to 32 alphanumeric/special characters. Blank by default. Double-click, enter the name, and press Enter . See the “ DLP-G104 Assign a Name to a Port ” task on page 7-3 .
Admin State	Sets the port service state unless network conditions prevent the change. For more information about administrative states, refer to the “Administrative and Service States” appendix in the <i>Cisco ONS 15454 DWDM Reference Manual</i> .	From the drop-down list, choose one of the following: <ul style="list-style-type: none"> IS/Unlocked IS,AINS/Unlocked,automaticInService OOS,DSBLD/Locked,disabled OOS,MT/Locked,maintenance

Table 11-34 MMU Optical Line Parameter Settings (continued)

Parameter	Description	Options
Service State	(Display only) Identifies the autonomously generated state that gives the overall condition of the port. Service states appear in the format: Primary State-Primary State Qualifier, Secondary State. For more information about service states, refer to the “Administrative and Service States” appendix in the <i>Cisco ONS 15454 DWDM Reference Manual</i> .	<ul style="list-style-type: none"> IS-NR/Unlocked-enabled OOS-AU,AINS/Unlocked-disabled, automaticInService OOS-MA,DSBLD/Locked-enabled,disabled OOS-MA,MT/Locked-enabled,maintenance
Line Direction	Shows the line direction associated with the optical signal that passes through the port. This parameter is automatically configured during ANS. To change it, you must modify the network plan in Cisco MetroPlanner, import the NE Update file and run ANS.	<ul style="list-style-type: none"> East to West West to East <p>The options cannot be modified.</p>
Power	(Display only) Power value read by the photodiode associated with the port.	Numeric value (dB)
AINS Soak	(Display only) Sets the automatic in-service soak period.	<ul style="list-style-type: none"> Duration of valid input signal, in hh.mm format, after which the card becomes in service (IS) automatically 0 to 48 hours, 15-minute increments

Step 4 Return to your originating procedure (NTP).

DLP-G343 Change the MMU Optical Line Thresholds

Purpose	This task changes the MMU card optical line threshold settings.
Tools/Equipment	None
Prerequisite Procedures	DLP-G46 Log into CTC, page 2-25
Required/As Needed	As needed
Onsite/Remote	Onsite or remote
Security Level	Provisioning or higher



Caution

Warning thresholds are not monitored by CTC. They must be user-provisioned and monitored through custom alarm profiles.

- Step 1** In node view (single-shelf mode) or shelf view (multishelf mode), double-click the MMU card where you want to change the optical line optics warning threshold settings.
- Step 2** Click the **Provisioning > Optical Line > Optics Thresholds** tabs.
- Step 3** If you want to change the warning thresholds, complete the following steps. If not, continue with [Step 4](#).
 - a.** Under Types, choose **Warning**.

- b. Choose the warning interval that you want to provision, either **15 minutes** or **1 Day**.
- c. Click **Refresh**.
- d. Modify any of the warning thresholds shown under the Options column in [Table 11-35](#).
- e. Click **Apply**. If the change affects traffic, a warning message displays. Click **Yes** to complete the change.

Table 11-35 MMU Optical Line Warning Threshold Settings

Parameter	Description	Options
Port	(Display only) Displays the port number, port type, and direction (RX or TX): <ul style="list-style-type: none"> • 1 (EXP-RX) • 2 (EXP-TX) • 3 (COM-RX) • 4 (COM-TX) • 5 (EXP A-RX) • 6 (EXP A-TX) 	—
opwrMin (dBm)	Set the low power warning level.	Numeric. Can be set for 15-minute or one-day intervals. The default is -50 dBm.
opwrMax (dBm)	Set the high power warning level.	Numeric. Can be set for 15-minute or one-day intervals. The default is 30 dBm.

- Step 4** If you want to change the alarm thresholds, complete the following steps. If not, continue with [Step 5](#).
- a. Under Types, choose **Alarm**.
 - b. Click **Refresh**.
 - c. Modify any of the alarm thresholds shown under the Options column in [Table 11-36](#).
 - d. Click **Apply**. If the change affects traffic, a warning message displays. Click **Yes** to complete the change.

Table 11-36 MMU Optical Line Alarm Threshold Settings

Parameter	Description	Options
Port	(Display only) Displays the port number, port type, and direction (RX or TX): <ul style="list-style-type: none"> • 1 (EXP-RX) • 2 (EXP-TX) • 3 (COM-RX) • 4 (COM-TX) • 5 (EXP A-RX) • 6 (EXP A-TX) 	—
Power Failure Low (dBm)	Shows the power failure low threshold. This power value applies to the corresponding port and is automatically calculated when ANS is run. You can manually change the threshold. The value must be within the optical power range that is specified for the card. (Refer to the “Hardware Specifications” appendix in the <i>Cisco ONS 15454 DWDM Reference Manual</i> .)	Numeric. Double-click the parameters, enter a value, and press Enter .

Step 5 Return to your originating procedure (NTP).

NTP-G101 Modify Alarm Interface Controller–International Settings

Purpose	This procedure provisions the AIC-I card to receive input from or send output to external devices wired to the backplane (called external alarms and controls or environmental alarms), or changes orderwire settings.
Tools/Equipment	None
Prerequisite Procedures	NTP-G72 Provision External Alarms and Controls on the Alarm Interface Controller-International Card, page 8-32 DLP-G109 Provision Orderwire, page 7-26
Required/As Needed	As needed
Onsite/Remote	Onsite or remote
Security Level	Provisioning or higher

Step 1 Complete the “[DLP-G46 Log into CTC](#)” task on page 2-25 at the node where you want to change the AIC-I card settings. If you are already logged in, proceed to [Step 2](#).

- Step 2** Complete the “[NTP-G103 Back Up the Database](#)” procedure on page 13-2.
- Step 3** Perform any of the following tasks as needed:
- [DLP-G245 Change External Alarms Using the AIC-I Card](#), page 11-63
 - [DLP-G246 Change External Controls Using the AIC-I Card](#), page 11-64
 - [DLP-G247 Change AIC-I Card Orderwire Settings](#), page 11-64
- Step 4** Complete the “[NTP-G103 Back Up the Database](#)” procedure on page 13-2.
- Stop.** You have completed this procedure.
-

DLP-G245 Change External Alarms Using the AIC-I Card

Purpose	This task changes external alarm settings on the AIC-I card.
Tools/Equipment	None
Prerequisite Procedures	DLP-G46 Log into CTC , page 2-25
Required/As Needed	As needed
Onsite/Remote	Onsite or remote
Security Level	Provisioning or higher



Note The procedure is the same if you are using the alarm expansion panel (AEP). In this case, the number of contacts that are shown on the screen is changed accordingly.

- Step 1** Confirm that external-device relays are wired to the ENVIR ALARMS IN pins. See the “[DLP-G20 Install Alarm Wires on the MIC-A/P \(ETSI Only\)](#)” task on page 1-47 (ETSI) or “[DLP-G23 Install Alarm Wires on the Backplane \(ANSI Only\)](#)” task on page 1-52 (ANSI) for more information.
- Step 2** Double-click the AIC-I card to display it in card view.
- Step 3** Click the **Provisioning > External Alarms** tabs.
- Step 4** Modify any of the following fields for each external device wired to the ONS 15454 backplane. For definitions of these fields, see the “[NTP-G72 Provision External Alarms and Controls on the Alarm Interface Controller-International Card](#)” procedure on page 8-32.
- Enabled
 - Alarm Type
 - Severity
 - Virtual Wire
 - Raised When
 - Description
- Step 5** Click **Apply**.
- Step 6** Return to your originating procedure (NTP).
-

DLP-G246 Change External Controls Using the AIC-I Card

Purpose	This task changes external control settings on the AIC-I card.
Tools/Equipment	None
Prerequisite Procedures	DLP-G46 Log into CTC, page 2-25
Required/As Needed	As needed
Onsite/Remote	Onsite or remote
Security Level	Provisioning or higher

Note

The task is the same if you are using the AEP. In this case, the number of contacts that are shown on the screen is changed accordingly.

-
- Step 1** Verify the external control relays to the ENVIR ALARMS OUT backplane pins. See the “[DLP-G20 Install Alarm Wires on the MIC-A/P \(ETSI Only\)](#)” task on page 1-47 (ETSI) or “[DLP-G23 Install Alarm Wires on the Backplane \(ANSI Only\)](#)” task on page 1-52 (ANSI) for more information.
- Step 2** In node view (single-shelf mode) or shelf view (multishelf mode), double-click the AIC-I card to display it in card view.
- Step 3** Click the **Provisioning > External Controls** tabs.
- Step 4** Modify any of the following fields for each external control wired to the ONS 15454 backplane. For definitions of these fields, see the “[NTP-G72 Provision External Alarms and Controls on the Alarm Interface Controller-International Card](#)” procedure on page 8-32.
- Enabled
 - Trigger Type
 - Control Type
 - Description
- Step 5** Click **Apply**.
- Step 6** Return to your originating procedure (NTP).
-

DLP-G247 Change AIC-I Card Orderwire Settings

Purpose	This task changes orderwire settings on the AIC-I card.
Tools/Equipment	None
Prerequisite Procedures	DLP-G46 Log into CTC, page 2-25
Required/As Needed	As needed
Onsite/Remote	Onsite or remote
Security Level	Provisioning or higher

**Caution**

When provisioning orderwire for ONS 15454s residing in a ring, do not provision a complete orderwire loop. For example, a four-node ring typically has east and west ports provisioned at all four nodes. However, to prevent orderwire loops, provision two orderwire ports (east and west) at all but one of the ring nodes.

**Tip**

Before you begin, make a list of the ONS 15454 slots and ports that require orderwire communication.

- Step 1** In node view (single-shelf mode) or shelf view (multishelf mode), double-click the AIC-I card to display it in card view.
- Step 2** Click the **Provisioning > Local Orderwire** tabs or the **Provisioning > Express Orderwire** tabs, depending on the orderwire path that you want to change. Provisioning steps are the same for both types of orderwire.
- Step 3** If needed, adjust the transmit (Tx) and receive (Rx) dBm values by moving the slider to the right or left for the headset type (four-wire or two-wire) that you will use. In general, you should not need to adjust the dBm values.
- Step 4** If you want to turn on the audible alert (buzzer) for the orderwire, check the **Buzzer On** check box.
- Step 5** Click **Apply**.
- Step 6** Return to your originating procedure (NTP).

NTP-G102 Change Card Service State

Purpose	This procedure changes a card service state.
Tools/Equipment	None
Prerequisite Procedures	NTP-G30 Install the DWDM Cards, page 3-44 or NTP-G32 Install the Transponder and Muxponder Cards, page 3-50
Required/As Needed	As needed
Onsite/Remote	Onsite or remote
Security Level	Provisioning or higher

- Step 1** Complete the “[DLP-G46 Log into CTC](#)” task on [page 2-25](#) at the node where you want to change the card service state.
- Step 2** In node view (single-shelf mode) or multishelf view (multishelf mode), click the **Inventory** tab.
- Step 3** Click the cell in the Admin State column for the card you want to change, and choose an administrative state from the drop-down list:
- **IS** (ANSI) or **Unlocked** (ETSI)
 - **OOS,MT** (ANSI) or **Locked-enabled** (ETSI)
- Step 4** Click **Apply**.

Step 5 If an error message appears indicating that the card state cannot be changed from its current state, click **OK**.

For information about the card state transitions, refer to the “Administrative and Service States” appendix in the *Cisco ONS 15454 DWDM Reference Manual*.

Stop. You have completed this procedure.



Add and Remove Cards and Nodes

This chapter provides procedures for adding and removing dense wavelength division multiplexing (DWDM) cards and nodes.



Note

Unless otherwise specified, “ONS 15454” refers to both ANSI and ETSI shelf assemblies.

Before You Begin

Before performing any of the following procedures, investigate all alarms and clear any trouble conditions. Refer to the *Cisco ONS 15454 DWDM Troubleshooting Guide* as necessary for general troubleshooting information and alarm or error descriptions.

This section lists the chapter procedures (NTPs). Turn to a procedure to view its tasks (DLPs).

1. [NTP-G107 Permanently Remove or Remove and Replace DWDM Cards, page 12-2](#)—Complete as needed.
2. [NTP-G127 Add an AD-xC-xx.x Card to an OADM Node, page 12-5](#)—Complete as needed.
3. [NTP-G129 Add a DWDM Node, page 12-8](#)—Complete as needed.
4. [NTP-G130 Remove a DWDM Node, page 12-10](#)—Complete as needed.
5. [NTP-G146 Add a Rack and/or Shelf to a Multishelf Node, page 12-13](#)—Complete as needed.
6. [NTP-G147 Delete a Shelf and/or Rack from a Multishelf Node, page 12-14](#)—Complete as needed.

NTP-G107 Permanently Remove or Remove and Replace DWDM Cards

Purpose	This procedure permanently removes or removes and replaces DWDM cards installed in the ONS 15454 shelf and rack.
Tools/Equipment	None
Prerequisite Procedures	NTP-G30 Install the DWDM Cards, page 3-44 NTP-G32 Install the Transponder and Muxponder Cards, page 3-50
Required/As Needed	As needed
Onsite/Remote	Onsite
Security Level	Provisioning or higher

**Caution**

Removing and replacing cards can be traffic affecting.

**Caution**

Do not use this procedure to replace a TCC2 or TCC2P card. To replace a TCC2/TCC2P card, refer to the *Cisco ONS 15454 DWDM Troubleshooting Guide*.

Step 1 Complete the “[DLP-G46 Log into CTC](#)” task on page 2-25.

**Note**

If you cannot log into Cisco Transport Controller (CTC) and you need to remove a card, remove the card as described in [Step 6](#). After you log into CTC, troubleshoot the mismatched equipment alarm (MEA) with the *Cisco ONS 15454 DWDM Troubleshooting Guide*.

Step 2 Click the **Alarms** tab.

- a. Verify that the alarm filter is not on. See the “[DLP-G128 Disable Alarm Filtering](#)” task on page 8-28 as necessary.
- b. Verify that no unexplained alarms appear on the network. If alarms appear, investigate and resolve them before continuing. Refer to the *Cisco ONS 15454 DWDM Troubleshooting Guide* for procedures.

Step 3 If you are removing and replacing a card, go to [Step 5](#).

Step 4 If you are permanently removing a card, go to [Step 11](#).

Step 5 To remove and replace a card, complete the following tasks, as needed:

- The circuits traversing through the card that needs to be replaced (for example, an amplifier) need to be protection switched. For instance, if the card you want to replace is an active transponder (TXP) or muxponder (MXP) in a Y-cable protection group, complete the “[DLP-G179 Apply a Force Y-Cable or Splitter Protection Switch](#)” task on page 10-38 to force traffic away from the TXP or MXP that you will remove. If the card you want to replace is the standby TXP or MXP in a Y-cable protection group, complete the “[DLP-G182 Apply a Lockout](#)” task on page 10-40 to prevent traffic from switching to the TXP or MXP that you will remove.
- If the card is used as a node timing reference, complete the “[NTP-G112 Change the Node Timing Reference](#)” procedure on page 13-17 to change the timing reference to a card that will not be removed.

- If the card is an OSCM or OSC-CSM with an optical service channel (OSC) or TXP, MXP cards with generic communications channel (GCC) termination, complete the “[NTP-G85 Modify or Delete OSC Terminations, DCC/GCC Terminations, and Provisionable Patchcords](#)” procedure on [page 10-42](#) to delete the termination and recreate it on a card that will not be removed.



Note If you delete a card in CTC but do not remove it from the shelf, it will reboot and reappear in CTC.

- Step 6** Physically remove the card:
- a. Disconnect any cables.
 - b. Open the card latches/ejectors.
 - c. Use the latches/ejectors to pull the card forward and away from the shelf.
- Step 7** Insert the new card using one of the following procedures as applicable:
- [NTP-G30 Install the DWDM Cards, page 3-44](#)
 - [NTP-G32 Install the Transponder and Muxponder Cards, page 3-50](#)
- Step 8** Continue with the “[NTP-G34 Install Fiber-Optic Cables on DWDM Cards and DCUs](#)” procedure on [page 3-56](#).
- Step 9** Complete the following tasks or procedures, as needed:
- If you switched a Y-cable protection group in [Step 5](#), complete the “[DLP-G180 Clear a Manual or Force Y-Cable or Splitter Protection Switch](#)” task on [page 10-39](#).
 - If you deleted circuits in [Step 5](#), complete the “[DLP-G105 Provision Optical Channel Network Connections](#)” task on [page 7-11](#).
 - If you switched the timing reference in [Step 5](#), complete the “[NTP-G112 Change the Node Timing Reference](#)” procedure on [page 13-17](#) to change the reference back to the new card.
 - If you deleted an OSC or GCC termination in [Step 5](#), complete the “[NTP-G38 Provision OSC Terminations](#)” procedure on [page 3-83](#) or the “[DLP-G76 Provision DCC/GCC Terminations](#)” task on [page 7-22](#).
- Step 10** Go to [Step 13](#).
- Step 11** To permanently remove a card, complete the following tasks:
- Delete the circuits associated with the card being removed. Complete the “[DLP-G106 Delete Optical Channel Network Connections](#)” task on [page 7-13](#), and the “[DLP-G347 Delete Optical Channel Client Connections](#)” task on [page 7-8](#) as needed.
 - Physically remove the card:
 - Disconnect any cables.
 - Open the card latches/ejectors.
 - Use the latches/ejectors to pull the card forward and away from the shelf.
- Step 12** If the card you are removing is an OSCM, OSC-CSM, DWDM Amplifier, or Filter card, complete the following tasks; otherwise, go to [Step 13](#).
- Reconfigure the circuits (OCHCC, OCHNC, Trails) as needed. Complete the “[DLP-G105 Provision Optical Channel Network Connections](#)” task on [page 7-11](#), and the “[DLP-G346 Provision Optical Channel Client Connections](#)” task on [page 7-4](#) as needed.
 - Reload ANS provisioning. Complete the “[NTP-G143 Import the Cisco MetroPlanner NE Update Configuration File](#)” task on [page 3-38](#).

- Relaunch ANS. Complete the “[NTP-G37 Run Automatic Node Setup](#)” task on page 3-82.

Step 13 Click the **Alarms** tab.

- Verify that the alarm filter is not on. See the “[DLP-G128 Disable Alarm Filtering](#)” task on page 8-28 as necessary.
- Verify that no unexplained alarms appear on the network. If alarms appear, investigate and resolve them. Refer to the *Cisco ONS 15454 DWDM Troubleshooting Guide* for procedures.

Stop. You have completed this procedure.

DLP-G254 Place OPT-BST, OPT-BST-E, OPT-BST-L, and OPT-PRE Ports Out of Service

Purpose	This task places OPT-BST, OPT-BST-E, OPT-BST-L, and OPT-PRE card ports out of service in preparation for card removal.
Tools/Equipment	None
Prerequisite Procedures	DLP-G46 Log into CTC, page 2-25
Required/As Needed	As needed
Onsite/Remote	Onsite or remote
Security Level	Provisioning or higher

- Step 1** On the shelf graphic in CTC, double-click the OPT-BST, OPT-BST-E, OPT-BST-L, or OPT-PRE card with the ports that you want to put out of service.
 - Step 2** Click the **Provisioning > Optical Line > Parameters** tabs.
 - Step 3** In the Admin State column for the card’s ports, choose **OOS,DSBLD** (ANSI) or **Locked,disabled** (ETSI) for each port that does not have an OOS-MA,DSBLD or Locked-enabled,disabled service state.
 - Step 4** Click **Apply**.
 - Step 5** In the confirmation dialog box, click **Yes**.
 - Step 6** Click the **Provisioning > Opt Apli Line > Parameters** tabs.
 - Step 7** In the Admin State column for the card’s ports, choose **OOS,DSBLD** or **Locked,disabled** (ETSI) for each port that does not have an OOS-MA,DSBLD or Locked,disabled service state.
 - Step 8** Click **Apply**.
 - Step 9** In the confirmation dialog box, click **Yes**.
 - Step 10** Return to your originating procedure (NTP).
-

DLP-G318 Place OPT-BST, OPT-BST-E, OPT-BST-L, and OPT-PRE Ports In Service

Purpose	This task places OPT-BST, OPT-BST-E, OPT-BST-L, and OPT-PRE card ports in service.
Tools/Equipment	None
Prerequisite Procedures	DLP-G46 Log into CTC, page 2-25
Required/As Needed	As needed
Onsite/Remote	Onsite or remote
Security Level	Provisioning or higher

-
- Step 1** On the shelf graphic in CTC, double-click the OPT-BST, OPT-BST-E, OPT-BST-L, or OPT-PRE card with the ports that you want to put in service.
- Step 2** Click the **Provisioning > Optical Line > Parameters** tabs.
- Step 3** In the Admin State column for the card's ports, choose **IS,AINS** (ANSI) or **Unlocked-automaticInService** (ETSI) for Port 1 (COM-RX) of the OPT-PRE or Ports 2 (OSC-RX) and 3 (COM-TX) of the OPT-BST, OPT-BST-E, or OPT-BST-L cards.
- Step 4** Click **Apply**.
- Step 5** In the confirmation dialog box, click **Yes**.
- Step 6** Return to your originating procedure (NTP).
-

NTP-G127 Add an AD-xC-xx.x Card to an OADM Node

Purpose	This procedure adds an AD-xC-xx.x card to an optical add/drop multiplexing (OADM) node.
Tools/Equipment	None
Prerequisite Procedures	Chapter 3, "Turn Up a Node" A Cisco MetroPlanner OADM site plan recalculated for the new OADM card
Required/As Needed	As needed
Onsite/Remote	Onsite
Security Level	Provisioning or higher



Note Do not begin this procedure until the Cisco MetroPlanner site plan has been recalculated with the new AD-xC-xx.x card added to the OADM node.



Note During this procedure, you will use TL1 commands to delete and recreate optical channel network connection (OCHNC) cross-connects. You might need to refer to the *Cisco ONS SONET TL1 Command Guide* or the *Cisco ONS 15454 SDH TL1 Command Guide*.

**Caution**

This procedure will affect the service of unprotected circuits that pass through the OADM node.

- Step 1** Complete the “[DLP-G46 Log into CTC](#)” task on page 2-25 at a node on the OADM network.
- Step 2** In node view (single-shelf mode) or multishelf view (multishelf mode), display the OADM node where you will add the card.
- Step 3** Click the **Circuits** tab.
- Step 4** Make a list of all OCHNCs and/or OCHCCs that are carried on the express path for both the east-to-west (E > W) and west-to-east (W > E) directions.
- Step 5** For OCHNCs and/or OCHCCs identified in [Step 4](#) that are routed on the active path of a splitter or Y-cable protection group, force the traffic to the protect path in the opposite side of the ring using the “[DLP-G179 Apply a Force Y-Cable or Splitter Protection Switch](#)” task on page 10-38.
- Step 6** Click the **Circuits** tab.
- Step 7** Complete the following steps for all OCHNCs and/or OCHCCs carried on the express path that were identified in [Step 4](#):
- Choose the OCHNC or OCHCC circuit(s) and click **Edit**. (To choose multiple circuits, press the Shift key while you click the circuits.)
 - In the Edit Circuit dialog box, click the **State** tab.
 - In the State field on the right, choose **OOS,DSBLD** (ANSI) or **Locked,disabled** (ETSI) from the drop-down list.
 - Click **Apply**.
 - Repeat Steps [a](#) through [d](#) for each OCHNC or OCHCC circuit.
- Step 8** From the Tools menu, choose **Open TL1 Connection**.
- Step 9** In the Select Node dialog box, choose the OADM node where you will add the AD-xC-xx.x card and click **OK**.
- Step 10** In the TL1 dialog box, use the **DLT-OCHNC** command to delete the OCHNC cross-connects for the express path OCHNC and/or the relative OCH-TRAIL for the OCHCCs listed in [Step 4](#), as follows:
`DLT-OCHNC:[<TID>]:<SRC>,<DST>:<CTAG>:::[CKTID=<CKTID>],[CMDMDE=<CMDMDE>];`
 where:
- <SRC> is the Source access identifier from the “CHANNEL” section. In 2-way wavelength connection sources both directions need to be indicated.
 - <DST> is the Destination access identifier from the “LINE” section. In 2-way wavelength connection sources both directions need to be indicated.
 - <CKTID> is the cross-connect ID. The default is Blank or None. String of ASCII characters. Maximum length is 48. If CKTID is empty or null the CKTID field will not be displayed.
 - <CMDMDE> is the command execution mode.
- For additional information, including valid command values, refer to the *Cisco ONS SONET TL1 Command Guide* or the *Cisco ONS 15454 SDH TL1 Command Guide*.
- Step 11** Click **Close** to close the TL1 dialog box.
- Step 12** In node view (single-shelf mode) or multishelf view (multishelf mode), click the **Provisioning > WDM-ANS > Internal Patchcords** tabs.

- Step 13** Highlight the two express connections that carry the deleted circuits passing through the node. (The express connections are the only ones connecting an EXP_TX port on the last west-side OADM card, W > E, with an EXP_RX port on the first east-side OADM card, W > E.)
- Step 14** Click **Delete**.
- Step 15** Remove the physical express cables between the EXP_TX and EXP_RX ports specified in [Step 13](#).
- Step 16** Insert the new AD-xC-xx.x card in the slot identified by your Cisco MetroPlanner site plan.
- Step 17** Complete the “[NTP-G34 Install Fiber-Optic Cables on DWDM Cards and DCUs](#)” procedure on [page 3-56](#) for the OADM node, following the new internal connections table generated by Cisco MetroPlanner.
- Step 18** Complete the “[NTP-G152 Create and Verify Internal Patchcords](#)” procedure on [page 3-80](#).
- Step 19** Import the recalculated OADM site parameters. See the “[NTP-G143 Import the Cisco MetroPlanner NE Update Configuration File](#)” task on [page 3-38](#).
- Step 20** In node view (single-shelf mode) or multishelf view (multishelf mode), click the **Provisioning > WDM-ANS > Port Status** tabs.
- Step 21** Click **Launch ANS**.
- Step 22** From the Tools menu, choose **Open TL1 Connection**.
- Step 23** In the Select Node dialog box, choose the OADM node and click **OK**.
- Step 24** In the TL1 dialog box, use the **ENT-OCHNC** command to create the OCHNC or relative OCH-Trail of the OCHCC cross-connects that were deleted in [Step 10](#), as follows:
- ```
ENT-OCHNC:[<TID>]:<SRC>,<DST>:<CTAG>::[<WCT>]:[CKTID=<CKTID>],
[CMDMDE=<CMDMDE>]:[<PST>[,<SST>]];
```
- where:
- <SRC> is the Source access identifier from the “CHANNEL” section. In 2-way wavelength connection sources both directions need to be indicated.
  - <DST> is the Destination access identifier from the “LINE” section. In 2-way wavelength connection sources both directions need to be indicated.
  - <WCT> Wavelength connection type, either 1WAY or 2WAY. The default is 1WAY.
  - <CKTID> is the cross-connect ID. The default is Blank or None. String of ASCII characters. Maximum length is 48. If CKTID is empty or null the CKTID field will not be displayed.
  - <CMDMDE> is the command execution mode.
  - <PST> is the primary state, either IS or OOS.
  - <SST> is the secondary state.
- For additional information and a list of valid command values, see the *Cisco ONS SONET TL1 Command Guide* or the *Cisco ONS 15454 SDH TL1 Command Guide*.
- Step 25** Click **Close** to close the TL1 dialog box.
- Step 26** In node view (single-shelf mode) or multishelf view (multishelf mode), click the **Circuits** tab.
- Step 27** Complete the following steps for all OCHNCs and/or OCHCCs set to OOS,DSBLD (ANSI) or Locked,disabled (ETSI) in [Step 7](#):
- a. Choose the OCHNC or OCHCC circuit(s) and click **Edit**. To choose multiple circuits, press the Shift key while you click the circuits.
  - b. In the Edit Circuit dialog box, click the **State** tab.

- c. In the State field on the right, choose **IS,AINS** (ANSI) or **Unlocked,automaticInService** (ETSI) from the drop-down list.
- d. Click **Apply**, and then click **OK**.

**Step 28** Complete the “[DLP-G180 Clear a Manual or Force Y-Cable or Splitter Protection Switch](#)” task on [page 10-39](#) for OCHNCs and/or OCHCCs that were switched to the opposite side of the ring as part of a splitter or Y-cable protection group to return the traffic to its condition before the card was added.

**Stop. You have completed this procedure.**

---

## NTP-G129 Add a DWDM Node

|                                |                                                                                                                |
|--------------------------------|----------------------------------------------------------------------------------------------------------------|
| <b>Purpose</b>                 | This procedure adds a DWDM node to an existing Multi-Service Transport Platform (MSTP) network.                |
| <b>Tools/Equipment</b>         | None                                                                                                           |
| <b>Prerequisite Procedures</b> | <a href="#">Chapter 3, “Turn Up a Node”</a><br>A Cisco MetroPlanner network plan recalculated for the new node |
| <b>Required/As Needed</b>      | As needed                                                                                                      |
| <b>Onsite/Remote</b>           | Onsite                                                                                                         |
| <b>Security Level</b>          | Provisioning or higher                                                                                         |



### Note

Do not begin this procedure until the Cisco MetroPlanner network plan has been updated and recalculated with the new DWDM node.

---



### Note

This procedure assumes all turn-up procedures provided in [Chapter 3, “Turn Up a Node,”](#) have been completed at the node that will be added. If this has not been completed, do not continue. Complete the turn up procedures at the new node before you complete this procedure.

---



### Note

During this procedure, you will use TL1 commands to delete and recreate OCHNC and OCHCC cross-connects. You might need to refer to the *Cisco ONS SONET TL1 Command Guide* or the *Cisco ONS 15454 SDH TL1 Command Guide*.

---



### Caution

To complete this procedure, a span will be disconnected where the new node is added. This will affect the service of any unprotected circuits that pass through that span.

---

**Step 1** At the node that will be added, complete the “[NTP-G51 Verify DWDM Node Turn-Up](#)” procedure on [page 6-2](#). If the node has not been turned up, do not continue. Complete procedures in [Chapter 3, “Turn Up a Node,”](#) and [Chapter 4, “Perform Node Acceptance Tests,”](#) then begin this procedure again.

**Step 2** If the Cisco MetroPlanner network design has not been updated and recalculated for the new node and client services, update and recalculate it now, following the procedures in the Cisco MetroPlanner documentation.

- Step 3** Identify the fiber spans that must be disconnected to insert the new node.
- Step 4** Complete the “[DLP-G46 Log into CTC](#)” task on page 2-25 at a DWDM node that is active on the network where you want to add the new DWDM node.
- Step 5** In network view, click the **Circuits** tab.
- Step 6** Identify the OCHCCs and/or OCHNCs that are carried on the fiber span express path that you identified in [Step 3](#) in both the east-to-west and west-to-east directions.
- Step 7** If the OCHCC and/or OCHNC circuit is on the active path and is protected by a splitter or Y-cable protection group, complete the “[DLP-G179 Apply a Force Y-Cable or Splitter Protection Switch](#)” task on page 10-38 to force traffic away from the span where the node will be added. If not, continue with [Step 8](#).
- Step 8** For each circuit identified in [Step 6](#) that was not switched in [Step 7](#) (unprotected circuits), complete the following steps:
- In network view, select the OCHNC and/or OCHCC circuit and click **Edit**.
  - In the Edit Circuit dialog box, click the **State** tab.
  - In the State field on the right, choose **OOS,DSBLD** (ANSI) or **Locked,disabled** (ETSI) from the drop-down list.
  - Click **Apply**, then click **OK**.
- Step 9** Remove the fibers from the cards at the adjacent nodes that will connect to the new node.
- Step 10** Install the fibers from the adjacent nodes that will connect to the new node using the “[NTP-G34 Install Fiber-Optic Cables on DWDM Cards and DCUs](#)” procedure on page 3-56.
- Step 11** Create cross-connects on the new node for all circuits identified in [Step 6](#):
- From the Tools menu, choose **Open TL1 Connection**.
  - In the Select Node dialog box, choose the new node and click **OK**.
  - In the TL1 dialog box, use the **ENT-OCHNC** command to create the OCHNC and/or OCHCC cross-connects for each unprotected pass-through circuit as follows:  

```
ENT-OCHNC:[<TID>]:<SRC>,<DST>:<CTAG>::[<WCT>]:[CKTID=<CKTID>],
[CMDMDE=<CMDMDE>]:[<PST>[,<SST>]];
```

where:

    - <SRC> is the Source access identifier from the “CHANNEL” section. In 2-way wavelength connection sources both directions need to be indicated.
    - <DST> is the Destination access identifier from the “LINE” section. In 2-way wavelength connection sources both directions need to be indicated.
    - <WCT> Wavelength connection type, either 1WAY or 2WAY. The default is 1WAY.
    - <CKTID> is the cross-connect ID. The default is Blank or None. String of ASCII characters. Maximum length is 48. If CKTID is empty or null the CKTID field will not be displayed.
    - <CMDMDE> is the command execution mode.
    - <PST> is the primary state, either IS or OOS.
    - <SST> is the secondary state.

For additional information and a list of valid command values, see the *Cisco ONS SONET TL1 Command Guide* or the *Cisco ONS 15454 SDH TL1 Command Guide*.
  - Click **Close** to close the TL1 dialog box.

- e. Repeat [Step 8](#) to change the circuits placed in OOS,DSBLD (ANSI) or Locked,disabled (ETSI) back in service by choosing IS-AINS (ANSI) or Unlocked,automaticInService (ETSI) in the State drop-down list.
- Step 12** Complete the “[DLP-G180 Clear a Manual or Force Y-Cable or Splitter Protection Switch](#)” task on [page 10-39](#) for the circuits that were switched in [Step 7](#) to return the traffic to its original paths.
- Step 13** Complete the “[DLP-G106 Delete Optical Channel Network Connections](#)” task on [page 7-13](#) for circuits identified in [Step 6](#) that will not be part of the traffic matrix after the node is added.
- Step 14** Divide the circuits that existed previously into two groups: those that will terminate in the new node and those that will pass through it.
- Step 15** For circuits that will terminate in the new node, complete the “[DLP-G106 Delete Optical Channel Network Connections](#)” task on [page 7-13](#) and then the “[DLP-G105 Provision Optical Channel Network Connections](#)” task on [page 7-11](#).
- Step 16** Complete the “[DLP-G105 Provision Optical Channel Network Connections](#)” task on [page 7-11](#) to create new circuits.

**Stop. You have completed this procedure.**

---

## NTP-G130 Remove a DWDM Node

|                                |                                                                 |
|--------------------------------|-----------------------------------------------------------------|
| <b>Purpose</b>                 | This procedure removes a node from a DWDM network.              |
| <b>Tools/Equipment</b>         | None                                                            |
| <b>Prerequisite Procedures</b> | <a href="#">Chapter 3, “Turn Up a Node”</a>                     |
|                                | A Cisco MetroPlanner network plan recalculated for the new node |
| <b>Required/As Needed</b>      | As needed                                                       |
| <b>Onsite/Remote</b>           | Onsite                                                          |
| <b>Security Level</b>          | Provisioning or higher                                          |



### Note

Do not begin this procedure until the Cisco MetroPlanner network plan has been updated and recalculated with the DWDM node removed.

---



### Note

During this procedure, you will use TL1 commands to delete and recreate OCHNC or OCHCC cross-connects. You might need to refer to the *Cisco ONS SONET TL1 Command Guide* or the *Cisco ONS 15454 SDH TL1 Command Guide*.

---



### Caution

This procedure will affect the service of unprotected circuits that pass through the span where the node will be removed.

---

- Step 1** If the Cisco MetroPlanner network design has not been updated and recalculated with the node removed, update and recalculate the design now, following the procedures in the Cisco MetroPlanner documentation.



- Step 2** Complete the “[NTP-G21 Log into the ONS 15454 GUI](#)” task on page 2-23 at the DWDM target node.
- Step 3** Click the **Circuits** tab.
- Step 4** Identify the OCHNCs and/or OCHCCs that pass through or are added and dropped at the node that will be removed (that is, the target node), in both the Side B-to-Side A and Side A-to-Side B directions.
- Step 5** Complete the “[DLP-G347 Delete Optical Channel Client Connections](#)” task on page 7-8 and/or the “[DLP-G106 Delete Optical Channel Network Connections](#)” task on page 7-13 to delete OCHCCs and/or OCHNCs identified in [Step 4](#) that terminate (add/drop) on the target DWDM node.
- Step 6** If OCHNC and/or OCHCC circuits pass through the target node on the active path and are protected by a splitter or Y-cable protection group, navigate to a node connected to the target node and complete the “[DLP-G179 Apply a Force Y-Cable or Splitter Protection Switch](#)” task on page 10-38 to force the traffic away from the node that will be deleted. Otherwise, continue with [Step 7](#).
- Step 7** Complete the following steps for each circuit identified in [Step 4](#) that was not deleted in [Step 5](#) or switched in [Step 6](#):
- Select the OCHNCs or OCHCCs and click **Edit**.
  - In the Edit Circuit dialog box, click the **State** tab.
  - In the State field, choose **OOS,DSBLD** (ANSI) or **Locked,disabled** (ETSI) from the drop-down list.
  - Click **Apply**, then click **OK**.
- Step 8** Delete the cross-connects on the target node for each circuit placed in the OOS-DSBLD or Locked,disabled state in [Step 7](#):
- From the Tools menu, choose **Open TL1 Connection**.
  - In the Select Node dialog box, select the new node and click **OK**.
  - In the TL1 dialog box, use the **DLT-OCHNC** command to delete the OCHNC cross-connects for each unprotected pass-through circuit as follows:  

```
DLT-OCHNC:[<TID>]:<SRC>,<DST>:<CTAG>:::[CKTID=<CKTID>],
[CMDMDE=<CMDMDE>];
```

where:

    - <SRC> is the source access identifier from the Channel section in a two-way wavelength.
    - <DST> is the destination access identifier from the LINEWL section in a two-way wavelength.
    - <CKTID> is the cross-connect ID. The default is Blank or None. CKTD is a string of ASCII characters. The maximum length is 48. If CKTID is empty or null, the CKTID field will not be displayed.
    - <CMDMDE> is the command execution mode. NORM mode is the default behavior for all commands but you can specify FRCD to force the system to override a state in which the command would normally be denied.

For additional information, including valid command values, refer to the *Cisco ONS SONET TL1 Command Guide* or the *Cisco ONS 15454 SDH and Cisco ONS 15600 SDH TL1 Command Guide*.
  - In the TL1 dialog box, use the **DLT-OCHCC** command to delete the OCHCC cross-connects for the express path OCHCC listed in [Step 4](#), using the following format:  

```
DLT-OCHCC:[<TID>]:<AID>:<CTAG>[:::[CKTID=<CKTID>],
```

where:

    - <AID> is the access identifier from the Channel section.

- <CKTID> is the cross-connect ID. The default is Blank or None. CKTD is a string of ASCII characters. The maximum length is 48. If CKTID is empty or null, the CKTID field will not be displayed.
- <CMDMDE> is the command execution mode. NORM mode is the default behavior for all commands but you can specify FRCD to force the system to override a state in which the command would normally be denied.
- <PST> is the Primary state, which indicates the current overall service condition of an entity. The default is IS (in service).
- <SST> is the Secondary state, which provides additional information pertaining to PST and PSTQ. The default is AINS.

For additional information, including valid command values, refer to the *Cisco ONS SONET TL1 Command Guide* or the *Cisco ONS 15454 SDH and Cisco ONS 15600 SDH TL1 Command Guide*.

- e. Click **Close** to close the TL1 dialog box.

**Step 9** Remove the fibers from the target node, and reconnect the fibers to the adjacent nodes.

**Step 10** Update the ANS parameters at the adjacent nodes:

- a. Display an adjacent node in node view.
- b. Complete the “[NTP-G143 Import the Cisco MetroPlanner NE Update Configuration File](#)” procedure on page 3-38 to load the new NE Update file onto the node.
- c. Complete the “[NTP-G37 Run Automatic Node Setup](#)” procedure on page 3-82 to recalculate the ANS parameters at the node.
- d. Display the next adjacent node in node view.
- e. Repeat Steps b and c for the second adjacent node.

**Step 11** Repeat [Step 7](#) to change the circuits placed in OOS,DSBLD (ANSI) or Locked,disabled (ETSI) back in service by changing the Target Circuit Admin State field to **IS-AINS** (ANSI) or **Unlocked,AutomaticInService** (ETSI).

**Step 12** Complete the “[DLP-G180 Clear a Manual or Force Y-Cable or Splitter Protection Switch](#)” task on page 10-39 for the OCHNCs and/or OCHCCs that were switched in [Step 6](#).

**Step 13** Complete the “[DLP-G346 Provision Optical Channel Client Connections](#)” task on page 7-4 and/or the “[DLP-G105 Provision Optical Channel Network Connections](#)” task on page 7-11 to recreate OCHCCs and/or OCHNCs identified in [Step 4](#) that originated or terminated on the removed DWDM node. Choose the new DWDM node as the start/end (add/drop, respectively) for each circuit.

**Stop. You have completed this procedure.**

---

# NTP-G146 Add a Rack and/or Shelf to a Multishelf Node

|                                |                                                                                                                                                                                                                                                                                                                                                                       |
|--------------------------------|-----------------------------------------------------------------------------------------------------------------------------------------------------------------------------------------------------------------------------------------------------------------------------------------------------------------------------------------------------------------------|
| <b>Purpose</b>                 | This procedure adds a rack and/or subtending shelf to a multishelf node.                                                                                                                                                                                                                                                                                              |
| <b>Tools/Equipment</b>         | None                                                                                                                                                                                                                                                                                                                                                                  |
| <b>Prerequisite Procedures</b> | One of the following: <ul style="list-style-type: none"> <li>• <a href="#">NTP-G145 Connect a Multishelf Node and Subtending Shelves to an MS-ISC-100T Card</a>, page 1-78, or</li> <li>• <a href="#">NTP-G158 Connect a Multishelf Node and Subtending Shelves to a Cisco Catalyst 2950</a>, page 1-80</li> </ul> <p><a href="#">Chapter 3, “Turn Up a Node”</a></p> |
| <b>Required/As Needed</b>      | As needed                                                                                                                                                                                                                                                                                                                                                             |
| <b>Onsite/Remote</b>           | Onsite                                                                                                                                                                                                                                                                                                                                                                |
| <b>Security Level</b>          | Provisioning or higher                                                                                                                                                                                                                                                                                                                                                |



## Note

Each shelf you want to add to a multishelf configuration must have network connectivity. For more information, see [Chapter 2, “Connect the PC and Log into the GUI.”](#)

- 
- Step 1** Complete the [“DLP-G46 Log into CTC” task on page 2-25](#) at the multishelf DWDM node where you want to add a shelf.
- Step 2** To add a rack, in multishelf view, right click the gray area and choose **Add Rack**. If you do not need to add a rack, continue with [Step 3](#).
- Step 3** To add a shelf, in multishelf view, right-click the white space inside the rack and choose **Add Shelf**.
- Step 4** In the Shelf ID Selection dialog box, choose a shelf ID from the drop-down list.
- Step 5** Click **OK**. The shelf appears in the multishelf view.
- Step 6** Complete the [“DLP-G46 Log into CTC” task on page 2-25](#) at the subtending shelf.
- Step 7** In multishelf view, click the **Provisioning > General > Multishelf Config** tabs.
- Step 8** Click **Enable as Subtended Shelf**.
- Step 9** From the Shelf ID drop-down list, choose the shelf ID that you created in [Step 4](#).
- Step 10** Click **Apply**.
- Step 11** In the confirmation dialog box, click **Yes** to reboot the shelf. The CTC view changes to network view and the node icon changes to gray. (This might take several minutes.)
- Step 12** If you are connecting the new subtending shelf to the EAP patch panel, complete the following steps. If not, continue with [Step 13](#).
- Using a cross-over (CAT 5) LAN cable, plug one connector into the front panel of the subtending shelf TCC2/TCC2P card in Slot 7 and plug the other end into the SSC port on the left patch panel.
  - Using a cross-over (CAT 5) LAN cable, plug one connector into the front panel of the subtending shelf TCC2/TCC2P card in Slot 11 and plug the other end into the SSC port on the right patch panel.
- Step 13** If you are connecting the subtending shelf to the Catalyst 2950 switch, complete the following steps. If not, continue with [Step 14](#).
- Plug one end of a cross-over (CAT-5) LAN cable into the front panel of the subtending shelf TCC2/TCC2P card in Slot 7 and plug the other end into Port 2 of the first Catalyst 2950.

- b. Plug one end of a cross-over (CAT-5) LAN cable into the front panel of the subtending shelf TCC2/TCC2P card in Slot 11 and plug the other end into Port 2 of the backup Catalyst 2950.

**Step 14** Repeat Steps 3 through 12 for each subtending shelf in the multishelf configuration.

**Stop.** You have completed this procedure.

## NTP-G147 Delete a Shelf and/or Rack from a Multishelf Node

|                                |                                                                                                                                                                                                                                                                                                                                                                |
|--------------------------------|----------------------------------------------------------------------------------------------------------------------------------------------------------------------------------------------------------------------------------------------------------------------------------------------------------------------------------------------------------------|
| <b>Purpose</b>                 | This procedure deletes a shelf and/or rack from a multishelf node in the CTC window.                                                                                                                                                                                                                                                                           |
| <b>Tools/Equipment</b>         | None                                                                                                                                                                                                                                                                                                                                                           |
| <b>Prerequisite Procedures</b> | One of the following: <ul style="list-style-type: none"> <li>• <a href="#">NTP-G145 Connect a Multishelf Node and Subtending Shelves to an MS-ISC-100T Card, page 1-78</a>, or</li> <li>• <a href="#">NTP-G158 Connect a Multishelf Node and Subtending Shelves to a Cisco Catalyst 2950, page 1-80</a></li> </ul> <a href="#">Chapter 3, “Turn Up a Node”</a> |
| <b>Required/As Needed</b>      | As needed                                                                                                                                                                                                                                                                                                                                                      |
| <b>Onsite/Remote</b>           | Onsite                                                                                                                                                                                                                                                                                                                                                         |
| <b>Security Level</b>          | Provisioning or higher                                                                                                                                                                                                                                                                                                                                         |



**Note** You cannot delete a node controller shelf from a multishelf node configuration.

**Step 1** Complete the “[DLP-G46 Log into CTC](#)” task on page 2-25 at the multishelf DWDM node where you want to delete a shelf or rack. If you want to delete a shelf, continue with [Step 2](#). If you want to delete a rack only, go to [Step 9](#).

**Step 2** Complete the following tasks, as needed:

- If cards on the shelf carry unprotected circuits, you must delete the circuits. Complete the “[DLP-G106 Delete Optical Channel Network Connections](#)” task on page 7-13 or the or the “[DLP-G347 Delete Optical Channel Client Connections](#)” task on page 7-8.
- If cards use internal patchcords, complete the “[DLP-G355 Delete an Internal Patchcord](#)” task on page 3-82.
- If cards on the shelf are an OSCM or OSC-CSM with an OSC or GCC termination, complete the “[NTP-G85 Modify or Delete OSC Terminations, DCC/GCC Terminations, and Provisionable Patchcords](#)” procedure on page 10-42.
- Put all ports in the Out-of-Service and Management, Disabled (OOS-MA,DSBLD) (ANSI) or Locked-enabled,disabled (ETSI) service state. For more information, see [Chapter 11, “Change DWDM Card Settings.”](#)



**Note** It is not necessary to delete the cards from the shelf before deleting a shelf.

**Step 3** From the View menu, choose **Go to Parent View** to return to multishelf view.

- Step 4** Right-click on the shelf in the rack for the subtending shelf you want to delete and choose **Delete Shelf**.
- Step 5** In the confirmation dialog box, click **Yes**.
- Step 6** To return the deleted shelf to a single-shelf node, you must use the LCD panel:
- Repeatedly press the **Status** button until Shelf Status appears.
  - Repeatedly press the **Port** button until Controller Status=MS Config appears.
  - Press **Status** again and press **Port** to set multishelf mode to MS=N.
  - Press **Status** to choose Done.
  - Repeatedly press **Status** until “Save and Reboot?” appears, and then press **Slot** to choose Apply. This reboots the shelf. A “Saving changes; TCC may reboot” message appears on the LCD.
- Step 7** After the TCC2/TCC2P reboot is complete, complete the following steps to disconnect the removed subtending shelf from the patch panel or Catalyst 2950.
- Remove the cross-over (CAT 5) LAN cable from the front panel of the TCC2/TCC2P card in Slot 7.
  - Remove the cross-over (CAT 5) LAN cable from the front panel of the TCC2/TCC2P card in Slot 11.
- Step 8** Reconnect the shelf to the LAN either on the backplane or one of the front panel TCC2/TCC2Ps. For more information, see [Chapter 2, “Connect the PC and Log into the GUI.”](#)
- Step 9** To delete an empty rack from the CTC window, right-click in the gray area on the rack graphic and choose **Delete Rack**.
- Stop. You have completed this procedure.**
-

■ NTP-G147 Delete a Shelf and/or Rack from a Multishelf Node



## Maintain the Node

This chapter provides procedures for maintaining the Cisco ONS 15454, including database backup and restoration, removing and replacing cards, viewing the ONS 15454 audit trail, and hardware maintenance procedures such as cleaning fibers, changing the fan tray filter, and other maintenance procedures.



**Note**

Unless otherwise specified, “ONS 15454” refers to both ANSI and ETSI shelf assemblies.

## Before You Begin

Before performing any of the following procedures, investigate all alarms and clear any trouble conditions. Refer to the *Cisco ONS 15454 DWDM Troubleshooting Guide* as necessary for general troubleshooting information and alarm or error descriptions.

This section lists the chapter procedures (NTPs). Turn to a procedure to view its tasks (DLPs).

1. [NTP-G103 Back Up the Database, page 13-2](#)—Complete as needed.
2. [NTP-G104 Restore the Database, page 13-3](#)—Complete as needed.
3. [NTP-G105 Restore the Node to Factory Configuration, page 13-4](#)—Complete as needed to clear the database and upload a blank database and the latest software.
4. [NTP-G133 View and Manage OSI Information, page 13-9](#)—Complete as needed.
5. [NTP-G106 Reset Cards Using CTC, page 13-12](#)—Complete as needed to reset the TCC2/TCC2P cards and the dense wavelength division multiplexing (DWDM) cards.
6. [NTP-G108 Viewing the Audit Trail Records, page 13-14](#)—Complete as needed.
7. [NTP-G109 Off-Load the Audit Trail Record, page 13-16](#)—Complete as needed.
8. [NTP-G110 Off-Load the Diagnostics File, page 13-17](#)—Complete as needed.
9. [NTP-G112 Change the Node Timing Reference, page 13-17](#)—Complete as needed.
10. [NTP-G113 View the ONS 15454 Timing Report, page 13-19](#)—Complete as needed.
11. [NTP-G114 Inspect, Clean, and Replace the Air Filter, page 13-22](#)—Complete as needed.
12. [NTP-G115 Clean Fiber Connectors, page 13-25](#)—Complete as needed.
13. [NTP-G40 Replace the Front Door, page 13-28](#)—Complete as needed.
14. [NTP-G116 Replace the Fan-Tray Assembly, page 13-30](#)—Complete as needed.
15. [NTP-G117 Replace the ANSI Shelf Alarm Interface Panel, page 13-35](#)—Complete as needed.

16. [NTP-G118 Replace the ANSI Shelf Plastic Lower Backplane Cover, page 13-39](#)—Complete as needed.
17. [NTP-G135 Edit Network Element Defaults, page 13-41](#)—Complete as needed to edit the factory-configured (default) network element (NE) settings for the Cisco ONS 15454.
18. [NTP-G136 Import Network Element Defaults, page 13-42](#)—Complete as needed to import the factory-configured (default) NE settings for the Cisco ONS 15454.
19. [NTP-G137 Export Network Element Defaults, page 13-43](#)—Complete as needed to export the factory-configured (default) NE settings for the Cisco ONS 15454.

## NTP-G103 Back Up the Database

|                                |                                                                                                                                                                  |
|--------------------------------|------------------------------------------------------------------------------------------------------------------------------------------------------------------|
| <b>Purpose</b>                 | This procedure stores a backup version of the TCC2/TCC2P (software) database on the workstation running Cisco Transport Controller (CTC) or on a network server. |
| <b>Tools/Equipment</b>         | None                                                                                                                                                             |
| <b>Prerequisite Procedures</b> | None                                                                                                                                                             |
| <b>Required/As Needed</b>      | Required. Cisco recommends performing a database backup at approximately weekly intervals and prior to and after configuration changes.                          |
| <b>Onsite/Remote</b>           | Onsite or remote                                                                                                                                                 |
| <b>Security Level</b>          | Maintenance or higher                                                                                                                                            |



### Note

You must back up and restore the database for each node on a circuit path in order to maintain a complete circuit.



### Note

The following parameters are not backed up and restored: node name, IP address, subnet mask and gateway, and Internet Inter-ORB Protocol (IPOP) port. If you change the node name and then restore a backed up database with a different node name, the circuits map to the new node name. Cisco recommends keeping a record of the old and new node names.

- Step 1** Complete the [“DLP-G46 Log into CTC” task on page 2-25](#) at the node you want to back up. If you are already logged in, continue with [Step 2](#).
- Step 2** In node view (single-shelf mode) or multishelf view (multishelf mode), click the Maintenance > Database tabs.
- Step 3** Click **Backup**.
- Step 4** Save the database on the workstation’s hard drive or on network storage. Use an appropriate file name with the DB file extension; for example, database.db.
- Step 5** Click **Save**.
- Step 6** Click **OK** in the confirmation dialog box.

**Stop. You have completed this procedure.**



# NTP-G104 Restore the Database

|                                |                                                                |
|--------------------------------|----------------------------------------------------------------|
| <b>Purpose</b>                 | This procedure restores the TCC2/TCC2P card software database. |
| <b>Tools/Equipment</b>         | None                                                           |
| <b>Prerequisite Procedures</b> | <a href="#">NTP-G103 Back Up the Database, page 13-2</a>       |
| <b>Required/As Needed</b>      | As needed                                                      |
| <b>Onsite/Remote</b>           | Onsite or remote                                               |
| <b>Security Level</b>          | Superuser                                                      |



## Note

The following parameters are not backed up and restored: node name, IP address, subnet mask and gateway, and IIOP port. If you change the node name and then restore a backed up database with a different node name, the circuits map to the new renamed node. Cisco recommends keeping a record of the old and new node names.



## Caution

If you are restoring the database on multiple nodes, wait approximately one minute after the TCC2/TCC2P card reboot has completed on each node before proceeding to the next node.

- Step 1** Complete the [“DLP-G46 Log into CTC” task on page 2-25](#) at the node where you are restoring the database. If you are already logged in, continue with Step 2.
- Step 2** In node view (single-shelf mode) or multishelf view (multishelf mode), click the **Circuits** tab. Verify that no optical channel network connection (OCHNC) circuits have a PARTIAL\_OOS state. If so, investigate and resolve the partial state before continuing.
- Step 3** Complete the [“DLP-G157 Disable Automatic Power Control” task on page 10-4](#).
- Step 4** In multishelf view (multishelf mode) or in node view (single-shelf mode), click the **Maintenance > Database** tabs.
- Step 5** Click **Restore**.
- Step 6** Locate the database file stored on the workstation hard drive or on network storage.  
To clear all existing provisioning, locate and upload the database found on the latest ONS 15454 software CD.
- Step 7** Click the database file to highlight it.
- Step 8** Click **OK**. The DB Restore dialog box appears. Opening a restore file from another node or from an earlier backup might affect traffic on the login node.
- Step 9** Click **Yes**.

The Restore Database dialog box monitors the file transfer ([Figure 13-1](#)).

**Figure 13-1 Restoring the Database—In-Process Notification**

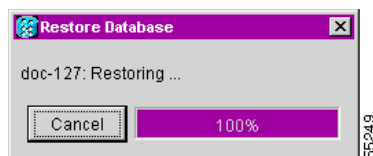

- Step 10** Wait for the file to complete the transfer to the TCC2/TCC2P card.
- Step 11** Click **OK** when the “Lost connection to node, changing to Network View” dialog box appears. Wait for the node to reconnect.
- Step 12** Complete the “[DLP-G158 Enable Automatic Power Control](#)” task on page 10-4.
- Stop. You have completed this procedure.**
- 

## NTP-G105 Restore the Node to Factory Configuration

|                                |                                                                                                                                                                                                                                                                                                                                                                                                                                |
|--------------------------------|--------------------------------------------------------------------------------------------------------------------------------------------------------------------------------------------------------------------------------------------------------------------------------------------------------------------------------------------------------------------------------------------------------------------------------|
| <b>Purpose</b>                 | This procedure reinitializes the ONS 15454 using the CTC reinitialization tool. Reinitialization uploads a new software package to the TCC2/TCC2P cards, clears the node database, and restores the factory default parameters.                                                                                                                                                                                                |
| <b>Tools/Equipment</b>         | ONS 15454 System Software CD, Version 7.0<br><br>Java Runtime Environment (JRE) 1.4.2 or JRE 5.0 must be installed on the computer to log into the node at the completion of the reinitialization. The reinitialization tool can run on JRE 1.3.1_02, JRE 1.4.2, or JRE 5.0.                                                                                                                                                   |
| <b>Prerequisite Procedures</b> | <a href="#">NTP-G103 Back Up the Database</a> , page 13-2<br><a href="#">NTP-G17 Set Up Computer for CTC</a> , page 2-1<br><br>One of the following: <ul style="list-style-type: none"> <li><a href="#">NTP-G18 Set Up CTC Computer for Local Craft Connection to the ONS 15454</a>, page 2-9, or</li> <li><a href="#">NTP-G19 Set Up a CTC Computer for a Corporate LAN Connection to the ONS 15454</a>, page 2-21</li> </ul> |
| <b>Required/As Needed</b>      | As needed                                                                                                                                                                                                                                                                                                                                                                                                                      |
| <b>Onsite/Remote</b>           | Onsite                                                                                                                                                                                                                                                                                                                                                                                                                         |
| <b>Security Level</b>          | Superuser                                                                                                                                                                                                                                                                                                                                                                                                                      |



### Caution

Cisco strongly recommends that you keep different node databases in separate folders. This is because the reinitialization tool chooses the first product-specific software package in the specified directory if you use the Search Path field instead of the Package and Database fields. You might accidentally copy an incorrect database if multiple databases are kept in the specified directory.

---



### Caution

Restoring a node to the factory configuration deletes all cross-connects on the node.

---



### Caution

Cisco recommends that you save the node database to safe location if you will not be restoring the node using the database provided on the software CD.

---

**Note**

The following parameters are not backed up and restored when you delete the database and restore the factory settings: node name, IP address, subnet mask and gateway, and IIOP port. If you change the node name and then restore a backed up database with a different node name, the circuits map to the new renamed node. Cisco recommends keeping a record of the old and new node names.

- 
- Step 1** If you need to install or replace one or more TCC2/TCC2P cards, see the [“DLP-G33 Install the TCC2 or TCC2P Card” task on page 1-73](#).
- Step 2** If you are using Microsoft Windows, complete the [“DLP-G248 Use the Reinitialization Tool to Clear the Database and Upload Software \(Windows\)” task on page 13-5](#).
- Step 3** If you are using UNIX, complete the [“DLP-G249 Use the Reinitialization Tool to Clear the Database and Upload Software \(UNIX\)” task on page 13-7](#).
- Stop. You have completed this procedure.**
- 

## DLP-G248 Use the Reinitialization Tool to Clear the Database and Upload Software (Windows)

|                                |                                                                                                                                                                                                                                                                                                                                                                                                                                  |
|--------------------------------|----------------------------------------------------------------------------------------------------------------------------------------------------------------------------------------------------------------------------------------------------------------------------------------------------------------------------------------------------------------------------------------------------------------------------------|
| <b>Purpose</b>                 | This task reinitializes the ONS 15454 using the CTC reinitialization tool on a Windows computer. Reinitialization uploads a new software package to the TCC2/TCC2P cards, clears the node database, and restores the factory default parameters.                                                                                                                                                                                 |
| <b>Tools/Equipment</b>         | ONS 15454 System Software CD, Version 7.0<br><br>JRE 1.4.2 or JRE 5.0 must be installed on the computer to log into the node at the completion of the reinitialization. The reinitialization tool can run on JRE 1.3.1_02, JRE 1.4.2, or JRE 5.0.                                                                                                                                                                                |
| <b>Prerequisite Procedures</b> | <a href="#">NTP-G103 Back Up the Database, page 13-2</a><br><a href="#">NTP-G17 Set Up Computer for CTC, page 2-1</a><br><br>One of the following: <ul style="list-style-type: none"> <li>• <a href="#">NTP-G18 Set Up CTC Computer for Local Craft Connection to the ONS 15454, page 2-9</a>, or</li> <li>• <a href="#">NTP-G19 Set Up a CTC Computer for a Corporate LAN Connection to the ONS 15454, page 2-21</a></li> </ul> |
| <b>Required/As Needed</b>      | As needed to clear the existing database from a TCC2/TCC2P and restore the node default settings.                                                                                                                                                                                                                                                                                                                                |
| <b>Onsite/Remote</b>           | Onsite                                                                                                                                                                                                                                                                                                                                                                                                                           |
| <b>Security Level</b>          | Superuser                                                                                                                                                                                                                                                                                                                                                                                                                        |

**Caution**

Restoring a node to the factory configuration deletes all cross-connects on the node.



**Note** The ONS 14545 Software CD is if the Reinit.jar file, the CISCO 15454 package file, and the NE default file are not stored on your computer.

- Step 1** Insert the ONS 15454 System Software CD, Version 7.0, into the computer CD-ROM drive. If the CTC Installation Wizard appears, click **Cancel**.
- Step 2** From the Windows Start menu, choose **Run**. In the Run dialog box, click **Browse** and navigate to the CISCO15454 or CISCO15454SDH folder on the software CD.
- Step 3** In the Browse dialog box Files of Type field, choose **All Files**.
- Step 4** Choose the RE-INIT.jar file and click **Open**. The NE Re-Initialization window appears (Figure 13-2).

**Figure 13-2 Reinitialization Tool**

**Step 5** Complete the following fields:

- **GNE IP**—If the node you are reinitializing is accessed through another node configured as a gateway network element (GNE), enter the GNE IP address. If you have a direct connection to the node, leave this field blank.
- **Node IP**—Enter the node name or IP address of the node that you are reinitializing.
- **User ID**—Enter the user ID needed to access the node.
- **Password**—Enter the password for the user ID.
- **Upload Package**—Check this box to send the software package file to the node. If unchecked, the software stored on the node is not modified.
- **Force Upload**—Check this box to send the software package file to the node even if the node is running the same software version. If unchecked, reinitialization will not send the software package if the node is already running the same version.
- **Activate/Revert**—Check this box to activate the uploaded software (if the software is a later than the installed version) or revert to the uploaded software (if the software is earlier than the installed version) as soon as the software file is uploaded. If unchecked, the software is not activated or reverted after the upload, allowing you to initiate the functions later from the node view Maintenance > Software tab.
- **Re-init Database**—Check this box to send a new database to the node. (This is equivalent to the CTC database restore operation.) If unchecked, the node database is not modified.
- **Confirm**—Check this box if you want a warning message displayed before any operation is performed. If unchecked, reinitialization does not display a warning message.

- Search Path—Enter the path to the CISCO15454 folder on the CD drive.

**Step 6** Click **Go**.



**Caution** Before continuing with the next step, verify that the database to upload is correct. You cannot reverse the upload process after you click Yes.

**Step 7** Review the information in the Confirm NE Re-Initialization dialog box, then click **Yes** to start the reinitialization.

The reinitialization begins. After the software is downloaded and activated, and the database is uploaded to the TCC2/TCC2P cards, “Complete” appears in the status bar and the TCC2/TCC2P cards will reboot. Wait a few minutes for the reboot to complete.

**Step 8** After the reboot is complete, log into the node using the [“DLP-G46 Log into CTC” task on page 2-25](#).

**Step 9** Complete the [“NTP-G24 Set Up Name, Date, Time, and Contact Information” procedure on page 3-10](#) and the [“NTP-G26 Set Up CTC Network Access” procedure on page 3-13](#).

**Step 10** Return to your originating procedure (NTP).

## DLP-G249 Use the Reinitialization Tool to Clear the Database and Upload Software (UNIX)

|                                |                                                                                                                                                                                                                                                                                                                                                                                                                              |
|--------------------------------|------------------------------------------------------------------------------------------------------------------------------------------------------------------------------------------------------------------------------------------------------------------------------------------------------------------------------------------------------------------------------------------------------------------------------|
| <b>Purpose</b>                 | This task reinitializes the ONS 15454 using the CTC reinitialization tool on a UNIX computer. Reinitialization uploads a new software package to the TCC2/TCC2P cards, clears the node database, and restores the factory default parameters.                                                                                                                                                                                |
| <b>Tools/Equipment</b>         | ONS 15454 SONET System Software CD, Version 5.0.x<br>JRE 1.4.2 or JRE 5.0 must be installed on the computer to log into the node at the completion of the reinitialization. The reinitialization tool can run on JRE 1.3.1_02, JRE 1.4.2, or JRE 5.0.                                                                                                                                                                        |
| <b>Prerequisite Procedures</b> | <a href="#">NTP-G103 Back Up the Database, page 13-2</a><br><a href="#">NTP-G17 Set Up Computer for CTC, page 2-1</a><br>One of the following: <ul style="list-style-type: none"> <li>• <a href="#">NTP-G18 Set Up CTC Computer for Local Craft Connection to the ONS 15454, page 2-9</a>, or</li> <li>• <a href="#">NTP-G19 Set Up a CTC Computer for a Corporate LAN Connection to the ONS 15454, page 2-21</a></li> </ul> |
| <b>Required/As Needed</b>      | As needed to clear the existing database from a TCC2/TCC2P and restore the node default settings.                                                                                                                                                                                                                                                                                                                            |
| <b>Onsite/Remote</b>           | Onsite                                                                                                                                                                                                                                                                                                                                                                                                                       |
| <b>Security Level</b>          | Superuser                                                                                                                                                                                                                                                                                                                                                                                                                    |



**Caution** Restoring a node to the factory configuration deletes all cross-connects on the node.

- 
- Step 1** Insert the system software CD containing the reinitialization tool, software, and defaults database into the computer CD-ROM drive. If the CTC Installation Wizard appears, click **Cancel**.
- Step 2** To find the recovery tool file, go to the CISCO15454 directory on the CD (usually /cdrom/cdrom0/CISCO15454 or /cdrom/cdrom0/CISCO15454SDH).
- Step 3** If you are using a file explorer, double-click the **RE-INIT.jar** file. If you are working with a command line, run **java -jar RE-INIT.jar**. The NE Re-Initialization window appears (Figure 13-2).
- Step 4** Complete the following fields:
- GNE IP—If the node you are reinitializing is accessed through another node configured as a GNE, enter the GNE IP address. If you have a direct connection to the node, leave this field blank.
  - Node IP—Enter the node name or IP address of the node that you are reinitializing.
  - User ID—Enter the user ID needed to access the node.
  - Password—Enter the password for the user ID.
  - Upload Package—Check this box to send the software package file to the node. If unchecked, the software stored on the node is not modified.
  - Force Upload—Check this box to send the software package file to the node even if the node is running the same software version. If unchecked, reinitialization will not send the software package if the node is already running the same version.
  - Activate/Revert—Check this box to activate the uploaded software (if the software is a later than the installed version) or revert to the uploaded software (if the software is earlier than the installed version) as soon as the software file is uploaded. If unchecked, the software is not activated or reverted after the upload, allowing you to initiate the functions later from the node view Maintenance > Software tab.
  - Re-init Database—Check this box to send a new database to the node. (This is equivalent to the CTC database restore operation.) If unchecked, the node database is not modified.
  - Confirm—Check this box if you want a warning message displayed before any operation is performed. If unchecked, reinitialization does not display a warning message.
  - Search Path—Enter the path to the CISCO15454 or CISCO15454SDH folder on the CD drive.
- Step 5** Click **Go**.
- 
-  **Caution** Before continuing with the next step, verify that the database to upload is correct. You cannot reverse the upload process after you click Yes.
- 
- Step 6** Review the information in the Confirm NE Re-Initialization dialog box, then click **Yes** to start the reinitialization.
- The reinitialization begins. After the software is downloaded and activated and the database is uploaded to the TCC2/TCC2P cards, “Complete” appears in the status bar and the TCC2/TCC2P cards will reboot. Wait a few minutes for the reboot to complete.
- Step 7** After the reboot is complete, log into the node using the [“DLP-G46 Log into CTC” task on page 2-25](#).
- Step 8** Complete the [“NTP-G24 Set Up Name, Date, Time, and Contact Information” procedure on page 3-10](#) and the [“NTP-G26 Set Up CTC Network Access” procedure on page 3-13](#).
- Step 9** Return to your originating procedure (NTP).
-

# NTP-G133 View and Manage OSI Information

|                                |                                                                                                                                                                                                                                                                                                                            |
|--------------------------------|----------------------------------------------------------------------------------------------------------------------------------------------------------------------------------------------------------------------------------------------------------------------------------------------------------------------------|
| <b>Purpose</b>                 | This procedure allows you to view and manage Open Systems Interconnection (OSI) including the End System to Intermediate System (ES-IS) and Intermediate System to Intermediate System (IS-IS) routing information tables, the Target Identifier Address Resolution Protocol (TARP) data cache, and the manual area table. |
| <b>Tools/Equipment</b>         | None                                                                                                                                                                                                                                                                                                                       |
| <b>Prerequisite Procedures</b> | <a href="#">NTP-G103 Back Up the Database, page 13-2</a><br><a href="#">NTP-G17 Set Up Computer for CTC, page 2-1</a><br><a href="#">NTP-G132 Provision OSI, page 3-27</a>                                                                                                                                                 |
| <b>Required/As Needed</b>      | As needed                                                                                                                                                                                                                                                                                                                  |
| <b>Onsite/Remote</b>           | Onsite or remote                                                                                                                                                                                                                                                                                                           |
| <b>Security Level</b>          | Provisioning or higher                                                                                                                                                                                                                                                                                                     |

**Note**

Additional information about the ONS 15454 implementation of OSI is provided in the “Management Network Connectivity” chapter in the *Cisco ONS 15454 DWDM Reference Manual*.

- Step 1** Complete the “[DLP-G46 Log into CTC](#)” task on page 2-25. If you are already logged in, continue with Step 2.
- Step 2** Perform any of the following tasks as needed:
- [DLP-G298 View IS-IS Routing Information Base, page 13-9](#)
  - [DLP-G299 View ES-IS Routing Information Base, page 13-10](#)
  - [DLP-G300 Manage the TARP Data Cache, page 13-11](#)

**Stop. You have completed this procedure.**

## DLP-G298 View IS-IS Routing Information Base

|                                |                                                                                                                                                                                                                                                                                                                                                              |
|--------------------------------|--------------------------------------------------------------------------------------------------------------------------------------------------------------------------------------------------------------------------------------------------------------------------------------------------------------------------------------------------------------|
| <b>Purpose</b>                 | This task allows you to view the IS-IS protocol routing information base (RIB). IS-IS is an OSI routing protocol that floods the network with information about NEs on the network. Each NE uses the information to build a complete and consistent picture of a network topology. The IS-IS RIB shows the network view from the perspective of the IS node. |
| <b>Tools/Equipment</b>         | None                                                                                                                                                                                                                                                                                                                                                         |
| <b>Prerequisite procedures</b> | <a href="#">DLP-G46 Log into CTC, page 2-25</a>                                                                                                                                                                                                                                                                                                              |
| <b>Required/As needed</b>      | As needed                                                                                                                                                                                                                                                                                                                                                    |
| <b>Onsite/Remote</b>           | Onsite or remote                                                                                                                                                                                                                                                                                                                                             |
| <b>Security Level</b>          | Provisioning or higher                                                                                                                                                                                                                                                                                                                                       |

- 
- Step 1** In node view (single-shelf mode) or multishelf view (multishelf mode), click the **Maintenance > OSI > IS-IS RIB** tabs.
- Step 2** View the following RIB information for Router 1:
- **Subnet Type**—Indicates the OSI subnetwork point of attachment type used to access the destination address. Subnet types include SDCC, LDCC, GCC, OSC, and LAN.
  - **Location**—Indicates the OSI subnetwork point of attachment. For data communications channel (DCC) subnets, the slot and port are displayed. LAN subnets are shown as LAN.
  - **Destination Address**—The destination Network Service Access Point (NSAP) of the IS.
  - **MAC Address**—For destination NEs that are accessed by LAN subnets, the NE's MAC address.
- Step 3** If additional routers are enabled, you can view their RIBs by choosing the router number in the Router field and clicking **Refresh**.
- Step 4** Return to your originating procedure (NTP).
- 

## DLP-G299 View ES-IS Routing Information Base

|                                |                                                                                                                                                                                                                                                                                                                                                     |
|--------------------------------|-----------------------------------------------------------------------------------------------------------------------------------------------------------------------------------------------------------------------------------------------------------------------------------------------------------------------------------------------------|
| <b>Purpose</b>                 | This task allows you to view the ES-IS protocol RIB. ES-IS is an OSI protocol that defines how end systems (hosts) and intermediate systems (routers) learn about each other. For ESs, the ES-IS RIB shows the network view from the perspective of the ES node. For ISs, the ES-IS RIB shows the network view from the perspective of the IS node. |
| <b>Tools/Equipment</b>         | None                                                                                                                                                                                                                                                                                                                                                |
| <b>Prerequisite procedures</b> | <a href="#">DLP-G46 Log into CTC, page 2-25</a>                                                                                                                                                                                                                                                                                                     |
| <b>Required/As needed</b>      | As needed                                                                                                                                                                                                                                                                                                                                           |
| <b>Onsite/Remote</b>           | Onsite or remote                                                                                                                                                                                                                                                                                                                                    |
| <b>Security Level</b>          | Provisioning or higher                                                                                                                                                                                                                                                                                                                              |

- 
- Step 1** In node view (single-shelf mode) or multishelf view (multishelf mode), click the **Maintenance > OSI > ES-IS RIB** tabs.
- Step 2** View the following RIB information for Router 1:
- **Subnet Type**—Indicates the OSI subnetwork point of attachment type used to access the destination address. Subnet types include SDCC, LDCC, GCC, OSC, and LAN.
  - **Location**—Indicates the subnet interface. For DCC subnets, the slot and port are displayed. LAN subnets are shown as LAN.
  - **Destination Address**—The destination IS NSAP.
  - **MAC Address**—For destination NEs that are accessed by LAN subnets, the NE's MAC address.
- Step 3** If additional routers are enabled, you can view their RIBs by choosing the router number in the Router field and clicking **Refresh**.
- Step 4** Return to your originating procedure (NTP).
-



## DLP-G300 Manage the TARP Data Cache

|                                |                                                                                                                                                   |
|--------------------------------|---------------------------------------------------------------------------------------------------------------------------------------------------|
| <b>Purpose</b>                 | This task allows you to view and manage the TARP data cache (TDC). The TDC facilitates TARP processing by storing a list of TID to NSAP mappings. |
| <b>Tools/Equipment</b>         | None                                                                                                                                              |
| <b>Prerequisite procedures</b> | <a href="#">DLP-G46 Log into CTC, page 2-25</a>                                                                                                   |
| <b>Required/As needed</b>      | As needed                                                                                                                                         |
| <b>Onsite/Remote</b>           | Onsite or remote                                                                                                                                  |
| <b>Security Level</b>          | Provisioning or higher                                                                                                                            |

**Step 1** In node view (single-shelf mode) or multishelf view (multishelf mode), click the **Maintenance > OSI > TDC** tabs.

**Step 2** View the following TDC information:

- **TID**—The target identifier of the originating NE. For ONS 15454s, the TID is the name entered in the Node Name/TID field on the Provisioning > General tab.
- **NSAP/NET**—The NSAP or Network Element Title (NET) of the originating NE.
- **Type**—Indicates how the TDC entry was created:
  - **Dynamic**—The entry was created through the TARP propagation process.
  - **Static**—The entry was manually created and is a static entry.

**Step 3** If you want to query the network for an NSAP that matches a TID, complete the following steps. Otherwise, continue with [Step 4](#).



**Note** The TID to NSAP function is not available if the TDC is not enabled on the Provisioning > OSI > TARP subtab.

- a. Click the **TID to NSAP** button.
- b. In the TID to NSAP dialog box, enter the TID you want to map to an NSAP.
- c. Click **OK**, then click **OK** in the information message box.
- d. On the TDC tab, click **Refresh**.

If TARP finds the TID in its TDC, it returns the matching NSAP. If not, TARP sends protocol data units (PDUs) across the network. Replies will return to the TDC later, and a check TDC later message is displayed.

**Step 4** If you want to delete all the dynamically generated TDC entries, click the **Flush Dynamic Entries** button. If not, continue with [Step 5](#).

**Step 5** Return to your originating procedure (NTP).

## NTP-G106 Reset Cards Using CTC

|                                |                                                                   |
|--------------------------------|-------------------------------------------------------------------|
| <b>Purpose</b>                 | This procedure resets the TCC2/TCC2P and DWDM cards using CTC.    |
| <b>Tools/Equipment</b>         | None                                                              |
| <b>Prerequisite Procedures</b> | <a href="#">DLP-G33 Install the TCC2 or TCC2P Card, page 1-73</a> |
| <b>Required/As Needed</b>      | As needed                                                         |
| <b>Onsite/Remote</b>           | Onsite or remote                                                  |
| <b>Security Level</b>          | Superuser                                                         |

- 
- Step 1** Complete the “[DLP-G46 Log into CTC](#)” task on page 2-25 at the node where you are performing the TCC2/TCC2P reset. If you are already logged in, continue with [Step 2](#).
- Step 2** As needed, complete the “[DLP-G250 Reset the TCC2/TCC2P Card](#)” task on page 13-12.
- Step 3** As needed, complete the “[DLP-G251 Reset DWDM Cards Using CTC](#)” task on page 13-13.
- Stop. You have completed this procedure.**
- 

## DLP-G250 Reset the TCC2/TCC2P Card

|                                |                                                                                                                      |
|--------------------------------|----------------------------------------------------------------------------------------------------------------------|
| <b>Purpose</b>                 | This task resets the TCC2/TCC2P card and switches the node to the redundant TCC2/TCC2P.                              |
| <b>Tools/Equipment</b>         | None                                                                                                                 |
| <b>Prerequisite Procedures</b> | <a href="#">DLP-G33 Install the TCC2 or TCC2P Card, page 1-73</a><br><a href="#">DLP-G46 Log into CTC, page 2-25</a> |
| <b>Required/As Needed</b>      | As needed                                                                                                            |
| <b>Onsite/Remote</b>           | Onsite or remote                                                                                                     |
| <b>Security Level</b>          | Superuser                                                                                                            |



### Warning

**Do not reach into a vacant slot or chassis while you install or remove a module or a fan. Exposed circuitry could constitute an energy hazard.** Statement 206



### Note

Before you reset the TCC2/TCC2P, you should wait at least 60 seconds after the last provisioning change you made to avoid losing any changes to the database.



### Note

When a software reset is performed on an active TCC2/TCC2P, the AIC-I card goes through an initialization process and also resets. The AIC-I card reset is normal and happens each time an active TCC2/TCC2P card goes through a software-initiated reset.

- 
- Step 1** In node view (single-shelf mode) or multishelf view (multishelf mode), click the **Alarms** tab.
- Verify that the alarm filter is not on. See the “[DLP-G128 Disable Alarm Filtering](#)” task on page 8-28 as necessary.
  - Verify that no unexplained alarms appear on the network. If alarms appear, investigate and resolve them before continuing. Refer to the *Cisco ONS 15454 DWDM Troubleshooting Guide* for procedures.
- Step 2** In node view, right-click the TCC2/TCC2P card to reveal a shortcut menu.
- Step 3** Click **Reset Card**.
- Step 4** Click **Yes** when the confirmation dialog box appears.
- Step 5** Click **Close** when the “Lost connection to node, changing to Network View” dialog box appears.
- Step 6** Return to node view (single-shelf mode) or multishelf view (multishelf mode) and confirm that the TCC2/TCC2P card LED is amber (standby).
- Step 7** Return to your originating procedure (NTP).
- 

## DLP-G251 Reset DWDM Cards Using CTC

|                                |                                                                                                                                                                                                |
|--------------------------------|------------------------------------------------------------------------------------------------------------------------------------------------------------------------------------------------|
| <b>Purpose</b>                 | This task resets the OSCM, OSC-CSM, 32MUX-O, 32DMX-O, 32DMX, 32WSS, OPT-BST, OPT-PRE, AD-xC.xx.x, AD-xB.xx.x, transponder (TXP), and muxponder (MXP) cards using CTC.                          |
| <b>Tools/Equipment</b>         | None                                                                                                                                                                                           |
| <b>Prerequisite Procedures</b> | <a href="#">NTP-G30 Install the DWDM Cards, page 3-44</a><br><a href="#">NTP-G32 Install the Transponder and Muxponder Cards, page 3-50</a><br><a href="#">DLP-G46 Log into CTC, page 2-25</a> |
| <b>Required/As Needed</b>      | As needed                                                                                                                                                                                      |
| <b>Onsite/Remote</b>           | Onsite or remote                                                                                                                                                                               |
| <b>Security Level</b>          | Superuser                                                                                                                                                                                      |



### Warning

**Do not reach into a vacant slot or chassis while you install or remove a module or a fan. Exposed circuitry could constitute an energy hazard.** Statement 206

---



### Note

ONS 15454 cards normally do not need to be reset. However, you might occasionally need to reset a card for testing or as an initial trouble-clearing step. For additional information, see the *Cisco ONS 15454 DWDM Troubleshooting Guide*.

---

- Step 1** If you will switch an active TXP or MXP card that is in a Y-cable protection group, complete the “[DLP-G179 Apply a Force Y-Cable or Splitter Protection Switch](#)” task on page 10-38. If not, continue with [Step 2](#).
- Step 2** Right-click the card that you want to reset to reveal a shortcut menu.
- Step 3** Click **Reset Card**.

- Step 4** Click **Yes** when the confirmation dialog box appears.
- The card LED on the ONS 15454 shelf graphic will go through the following sequence: Fail (white LED), Ldg (white LED), and Act (green LED). The reset should complete within 1 to 2 minutes.
- Step 5** If you performed a Y-cable protection group switch in [Step 1](#), complete the “[DLP-G180 Clear a Manual or Force Y-Cable or Splitter Protection Switch](#)” task on [page 10-39](#). If not, continue with [Step 6](#).
- Step 6** Return to your originating procedure (NTP).
- 

## NTP-G108 Viewing the Audit Trail Records

|                                |                                                                                                                                                                                                                                                                                                |
|--------------------------------|------------------------------------------------------------------------------------------------------------------------------------------------------------------------------------------------------------------------------------------------------------------------------------------------|
| <b>Purpose</b>                 | This procedure explains how to view audit trail records. Audit trail records are useful for maintaining security, recovering lost transactions, and enforcing accountability. Accountability refers to tracing user activities; that is, associating a process or action with a specific user. |
| <b>Tools/Equipment</b>         | None                                                                                                                                                                                                                                                                                           |
| <b>Prerequisite Procedures</b> | None                                                                                                                                                                                                                                                                                           |
| <b>Required/As Needed</b>      | As needed                                                                                                                                                                                                                                                                                      |
| <b>Onsite/Remote</b>           | Onsite or remote                                                                                                                                                                                                                                                                               |
| <b>Security Level</b>          | Provisioning or higher                                                                                                                                                                                                                                                                         |

---

- Step 1** Complete the “[DLP-G46 Log into CTC](#)” task on [page 2-25](#) at the node where you want to view the audit trail log. If you are already logged in, continue with [Step 2](#).
- Step 2** In node view (single-shelf mode) or multishelf view (multishelf mode), click, click the **Maintenance > Audit** tabs.
- Step 3** Click **Retrieve**.
- A window containing the most recent audit trail records appears as shown in [Figure 13-3](#).

Figure 13-3 Viewing the Audit Trail Records

| Database          | Date              | Num | User    | P/F | Operation                                                                                                |
|-------------------|-------------------|-----|---------|-----|----------------------------------------------------------------------------------------------------------|
| Ether Bridge      | 03/13/04 06:01:08 | 8   | tCORBA  | F   | Security::General::login("CISCO15", "64.101.4.221", "FAIL - Password")                                   |
| Protection        | 03/13/04 06:01:42 | 12  | tCORBA  | F   | Security::General::login("CISCO15", "64.101.4.221", "FAIL - Password")                                   |
| BLSR              | 03/13/04 06:02:09 | 16  | tCORBA  | F   | Security::General::login("CISCO15", "64.101.4.221", "FAIL - Password")                                   |
| Software          | 03/16/04 02:19:49 | 49  | tCORBA  | F   | Security::General::login("CISCO15", "64.101.146.148", "FAIL - Password")                                 |
| Cross-Connect     | 03/16/04 02:23:49 | 58  | CISCO15 | F   | Equipment::EntityTable::provisionModule(SLOT-3, DS3_EC1_48_CARD)                                         |
| Overhead XConnect | 03/16/04 02:24:02 | 60  | CISCO15 | F   | Equipment::EntityTable::provisionModule(SLOT-3, DS3_EC1_48_CARD)                                         |
| Diagnostic        | 03/17/04 04:12:53 | 99  | CISCO15 | F   | SonetTopology::StsCircuitPart::setAdminState(occ, cf.d3.14.22:1)                                         |
| Timing            | 03/19/04 06:32:49 | 114 | tCORBA  | F   | Security::General::login("CISCO15", "64.101.7.46", "FAIL - Password")                                    |
| Audit             | 03/19/04 06:33:20 | 115 | tCORBA  | F   | Security::General::login("CISCO15", "64.101.7.46", "FAIL - Password")                                    |
| Routing Table     | 03/19/04 06:33:56 | 116 | tCORBA  | F   | Security::General::login("CISCO15", "64.101.7.46", "FAIL - Username")                                    |
| RIP Routing Table | 03/19/04 06:36:12 | 117 | tCORBA  | F   | Security::General::login("CISCO15", "64.101.7.46", "FAIL - Password")                                    |
| DWDM              | 03/23/04 06:21:29 | 187 | CISCO15 | F   | Equipment::Module::unprovision(SLOT-12)                                                                  |
|                   | 03/23/04 06:23:43 | 188 | CISCO15 | F   | Equipment::Module::unprovision(SLOT-12)                                                                  |
|                   | 03/23/04 06:24:21 | 190 | CISCO15 | F   | Equipment::Module::unprovision(SLOT-12)                                                                  |
|                   | 03/23/04 06:28:21 | 203 | CISCO15 | F   | Equipment::Module::unprovision(SLOT-5)                                                                   |
|                   | 03/23/04 06:28:52 | 204 | CISCO15 | F   | Equipment::Module::unprovision(SLOT-5)                                                                   |
|                   | 03/26/04 04:44:54 | 328 | CISCO15 | F   | Equipment::EntityTable::provisionModule(SLOT-17, DS3_EC1_48_CARD)                                        |
|                   | 03/27/04 05:50:35 | 354 | CISCO15 | F   | Equipment::Module::unprovision(SLOT-3)                                                                   |
|                   | 03/30/04 01:28:45 | 413 | CISCO15 | F   | Equipment::Module::unprovision(SLOT-5)                                                                   |
|                   | 03/30/04 01:33:14 | 419 | CISCO15 | F   | Equipment::Module::unprovision(SLOT-5)                                                                   |
|                   | 03/13/04 05:52:31 | 1   | tlrit   | P   | Event::EventManager::RegisterClient("SNMPproxy", "IOR:00dfdfdf0000001e49444c3a43616c6c6261636b2f457665") |
|                   | 03/13/04 05:52:31 | 2   | tlrit   | P   | Event::EventManager::RegisterClient("TL1proxy", "IOR:00dfdfdf0000001e49444c3a43616c6c6261636b2f457665")  |
|                   | 03/13/04 05:53:56 | 3   | tlrit   | P   | Event::EventManager::RegisterClient("SNMPproxy", "IOR:00dfdfdf0000001e49444c3a43616c6c6261636b2f457665") |
|                   | 03/13/04 05:53:56 | 4   | tlrit   | P   | Event::EventManager::RegisterClient("TL1proxy", "IOR:00dfdfdf0000001e49444c3a43616c6c6261636b2f457665")  |
|                   | 03/13/04 06:00:53 | 5   | tCORBA  | P   | Security::General::login("CISCO15", "64.101.4.221", "64.101.4.221", "SUCCESS")                           |

A definition of each column in the audit trail log is listed in Table 13-1.

Table 13-1 Audit Trail Column Definitions

| Column    | Definition                                                    |
|-----------|---------------------------------------------------------------|
| Date      | Date when the action occurred in the format MM/dd/yy HH:mm:ss |
| Num       | Incrementing count of actions                                 |
| User      | User ID that initiated the action                             |
| P/F       | Pass/Fail (that is, whether or not the action was executed)   |
| Operation | Action that was taken                                         |

Left-click the column headings to display the list in ascending-to-descending or descending-to-ascending order.

Right-click the column heading to display the following options:

- Reset Sorting—Resets the column to the default setting.
- Hide Column—Hides the column from view.
- Sort Column—Sorts the table by the column's values.
- Sort Column (incremental)—Sorts the table incrementally by multiple columns.
- Reset Columns Order/Visibility—Displays all hidden columns.
- Row Count—Provides a numerical count of log entries.

Shift-click the column heading for an incremental sort of the list.

**Stop. You have completed this procedure.**

# NTP-G109 Off-Load the Audit Trail Record

|                                |                                                                                                                                                                                                                                                                                  |
|--------------------------------|----------------------------------------------------------------------------------------------------------------------------------------------------------------------------------------------------------------------------------------------------------------------------------|
| <b>Purpose</b>                 | This procedure describes how to off-load up to 640 audit trail log entries in a local or network drive file to maintain a record of actions performed for the node. If the audit trail log is not off-loaded, the oldest entries are overwritten after the log reaches capacity. |
| <b>Tools/Equipment</b>         | None                                                                                                                                                                                                                                                                             |
| <b>Prerequisite Procedures</b> | None                                                                                                                                                                                                                                                                             |
| <b>Required/As Needed</b>      | As needed                                                                                                                                                                                                                                                                        |
| <b>Onsite/Remote</b>           | Onsite or remote                                                                                                                                                                                                                                                                 |
| <b>Security Level</b>          | Provisioning or higher                                                                                                                                                                                                                                                           |

- 
- Step 1** Complete the “[DLP-G46 Log into CTC](#)” task on page 2-25 at the node where you want to off-load the audit trail log. If you are already logged in, continue with [Step 2](#).
- Step 2** In node view (single-shelf mode) or multishelf view (multishelf mode), click, click the **Maintenance > Audit** tabs.
- Step 3** Click **Retrieve**.
- Step 4** Click **Archive**.
- Step 5** In the Archive Audit Trail dialog box, navigate to the directory (local or network) where you want to save the file.
- Step 6** Enter a name in the File Name field.
- You do not have to give the archive file a particular extension. It is readable in any application that supports text files, such as WordPad, Microsoft Word (imported), etc.
- Step 7** Click **Save**. Click **OK**.

The 640 entries are saved in this file. The next entries continue with the next number in the sequence, rather than starting over.



---

**Note** Archiving does not delete entries from the CTC audit trail log. However, entries can be self-deleted by the system after the log maximum is reached. If you archived the entries, you cannot reimport the log file back into CTC and will have to view the log in a different application.

---

**Stop. You have completed this procedure.**

---

## NTP-G110 Off-Load the Diagnostics File

|                                |                                                                                                                                                                                                                                                                             |
|--------------------------------|-----------------------------------------------------------------------------------------------------------------------------------------------------------------------------------------------------------------------------------------------------------------------------|
| <b>Purpose</b>                 | This procedure describes how to off-load a diagnostic file. The diagnostic file contains a set of debug commands that were run on a node and their results. This file is useful to the Cisco Technical Assistance Center (TAC) when troubleshooting problems with the node. |
| <b>Tools/Equipment</b>         | None                                                                                                                                                                                                                                                                        |
| <b>Prerequisite Procedures</b> | None                                                                                                                                                                                                                                                                        |
| <b>Required/As Needed</b>      | As needed                                                                                                                                                                                                                                                                   |
| <b>Onsite/Remote</b>           | Onsite or remote                                                                                                                                                                                                                                                            |
| <b>Security Level</b>          | Maintenance or higher                                                                                                                                                                                                                                                       |

- 
- Step 1** Complete the “[DLP-G46 Log into CTC](#)” task on page 2-25 at the node where you want to off-load the diagnostics file. If you are already logged in, continue with [Step 2](#).
- Step 2** In node view (single-shelf mode) or multishelf view (multishelf mode), click the **Maintenance > Diagnostic** tabs.
- Step 3** Click **Retrieve Tech Support Log**.
- Step 4** In the Saving Diagnostic File dialog box, navigate to the directory (local or network) where you want to save the file.
- Step 5** Enter a name in the File Name field.
- You do not have to give the archive file a particular extension. It is a compressed file (gzip) that can be unzipped and read by Cisco Technical Support.
- Step 6** Click **Save**.
- The Get Diagnostics status window shows a progress bar indicating the percentage of the file being saved, then shows “Get Diagnostics Complete.”
- Step 7** Click **OK**.
- Stop. You have completed this procedure.**
- 

## NTP-G112 Change the Node Timing Reference

|                                |                                                                                                             |
|--------------------------------|-------------------------------------------------------------------------------------------------------------|
| <b>Purpose</b>                 | This procedure enables automatic timing reference switching or returns the node timing to normal operation. |
| <b>Tools/Equipment</b>         | None                                                                                                        |
| <b>Prerequisite Procedures</b> | <a href="#">NTP-G53 Set Up Timing</a> , page 6-4                                                            |
| <b>Required/As Needed</b>      | As needed                                                                                                   |
| <b>Onsite/Remote</b>           | Onsite or remote                                                                                            |
| <b>Security Level</b>          | Maintenance or higher                                                                                       |

- 
- Step 1** Complete the “[DLP-G46 Log into CTC](#)” task on page 2-25 at the node where you want to enable timing switching. If you are already logged in, continue with [Step 2](#).

- Step 2** Complete the “[DLP-G259 Manual or Force Switch the Node Timing Reference](#)” task on page 13-18 as needed.
- Step 3** Complete the “[DLP-G260 Clear a Manual or Force Switch on a Node Timing Reference](#)” task on page 13-19 as needed.

**Stop.** You have completed this procedure.

---

## DLP-G259 Manual or Force Switch the Node Timing Reference

|                                |                                                                                  |
|--------------------------------|----------------------------------------------------------------------------------|
| <b>Purpose</b>                 | This task commands the node to switch to the timing reference you have selected. |
| <b>Tools/Equipment</b>         | None                                                                             |
| <b>Prerequisite Procedures</b> | <a href="#">DLP-G46 Log into CTC, page 2-25</a>                                  |
| <b>Required/As Needed</b>      | As needed                                                                        |
| <b>Onsite/Remote</b>           | Onsite or remote                                                                 |
| <b>Security Level</b>          | Maintenance or higher                                                            |

---

- Step 1** In node view (single-shelf mode) or multishelf view (multishelf mode), click the **Maintenance > Timing > Source** tabs.
- Step 2** From the Reference drop-down list for the desired Clock, choose the desired reference.
- Step 3** From the Operation drop-down list for the desired Clock, choose one of the following options:
- **Manual**—This operation commands the node to switch to the reference you have selected if the synchronization status message (SSM) quality of the reference is not lower than the current timing reference.
  - **Force**—This operation commands the node to switch to the reference you have selected, regardless of the SSM quality (if the reference is valid).



**Note** For information about the Clear option, see the “[DLP-G260 Clear a Manual or Force Switch on a Node Timing Reference](#)” task on page 13-19.

---

- Step 4** Click **Apply** next to the timing source.
- Step 5** Click **Yes** in the confirmation dialog box. If the selected timing reference is an acceptable valid reference, the node switches to the selected timing reference. If the selected timing reference is invalid, a warning dialog box appears. Click **OK**; the node will not switch to the new timing reference.
- Step 6** Return to your originating procedure (NTP).
-



## DLP-G260 Clear a Manual or Force Switch on a Node Timing Reference

|                                |                                                                                                                                     |
|--------------------------------|-------------------------------------------------------------------------------------------------------------------------------------|
| <b>Purpose</b>                 | This task clears a Manual or Force switch on a node timing reference and reverts the timing reference to its provisioned reference. |
| <b>Tools/Equipment</b>         | None                                                                                                                                |
| <b>Prerequisite Procedures</b> | <a href="#">DLP-G46 Log into CTC, page 2-25</a>                                                                                     |
| <b>Required/As Needed</b>      | As needed                                                                                                                           |
| <b>Onsite/Remote</b>           | Onsite or remote                                                                                                                    |
| <b>Security Level</b>          | Maintenance or higher                                                                                                               |

- 
- Step 1** In node view (single-shelf mode) or multishelf view (multishelf mode), click the **Maintenance > Timing > Source** tabs.
- Step 2** Find the Clock reference that is currently set to Manual or Force in the Operation drop-down list.
- Step 3** From the Operation drop-down list, choose **Clear**.
- Step 4** Click **Apply**.
- Step 5** Click **Yes** in the confirmation dialog box. If the normal timing reference is an acceptable valid reference, the node switches back to the normal timing reference as defined by the system configuration. If the normal timing reference is invalid or has failed, a warning dialog box appears. Click **OK**; the timing reference will not revert.
- Step 6** Return to your originating procedure (NTP).
- 

## NTP-G113 View the ONS 15454 Timing Report

|                                |                                                                                |
|--------------------------------|--------------------------------------------------------------------------------|
| <b>Purpose</b>                 | This procedure displays the current status of the ONS 15454 timing references. |
| <b>Tools/Equipment</b>         | None                                                                           |
| <b>Prerequisite Procedures</b> | <a href="#">NTP-G53 Set Up Timing, page 6-4</a>                                |
| <b>Required/As Needed</b>      | As needed                                                                      |
| <b>Onsite/Remote</b>           | Onsite or remote                                                               |
| <b>Security Level</b>          | Maintenance or higher                                                          |

- 
- Step 1** Complete the “[DLP-G46 Log into CTC](#)” task on page 2-25 at the node where you want to view the node timing status. If you are already logged in, continue with [Step 2](#).
- Step 2** In node view (single-shelf mode) or multishelf view (multishelf mode), click the **Maintenance > Timing > Report** tabs.
- Step 3** In the Timing Report area, you can view node timing information. The date and time of the report appear at the top of the report. The time stamp is the same as the alarms time stamp and can be configured using the “[DLP-G118 Display Alarms and Conditions Using Time Zone](#)” task on page 8-11. [Table 13-2](#) describes the report fields and entries.
- Step 4** To update the report, click **Refresh**.

Table 13-2 ONS 15454 Timing Report

| Item   | Description                                                                                        | Option                  | Option Description                                                                                                                                                                                                                                                                                                                                                            |
|--------|----------------------------------------------------------------------------------------------------|-------------------------|-------------------------------------------------------------------------------------------------------------------------------------------------------------------------------------------------------------------------------------------------------------------------------------------------------------------------------------------------------------------------------|
| Clock  | Indicates the timing clock. The report section that follows applies to the timing clock indicated. | NE                      | The node timing clock.                                                                                                                                                                                                                                                                                                                                                        |
|        |                                                                                                    | BITS-1 Out              | The BITS-1 Out timing clock.                                                                                                                                                                                                                                                                                                                                                  |
|        |                                                                                                    | BITS-2 Out              | The BITS-2 Out timing clock.                                                                                                                                                                                                                                                                                                                                                  |
| Status | Indicates the status of the timing clock.                                                          | INIT_STATE              | The timing reference has not been provisioned. For an NE reference, this status appears just before the first provisioning messages when the TCC2/TCC2P card is booting. Timing is provisioned to the internal clock of the node.                                                                                                                                             |
|        |                                                                                                    | HOLDOVER_STATE          | The clock was locked onto a valid timing reference for more than 140 seconds when a failure occurred. Holdover state timing is a computation based on timing during the normal state combined with the node's internal clock. The node holds onto this frequency until the valid reference is restored. This status appears for NE references only.                           |
|        |                                                                                                    | FREERUN_STATE           | The node is running off its internal clock without any modification except the calibrated value to bring timing to 0 PPM. Freerun state can occur when a Force switch to the Internal clock is initiated, when all references fail without the 140 seconds of holdover data, or when only Internal timing references are defined. This status appears for NE references only. |
|        |                                                                                                    | NO_SYNC_STATE           | A synchronization timing reference is not defined. BITS-1 Out or BITS-2 Out default to this status until an OC-N/STM-N card is defined as its reference on the Provisioning > Timing tab. This status appears for external references only.                                                                                                                                   |
|        |                                                                                                    | NE_SYNCH_STATE          | BITS-1 Out and BITS-2 Out use the same timing source as the NE. This is displayed when NE Reference is selected in the BITS-1 Out and BITS-2 Out Reference List on the Provisioning > Timing tab.                                                                                                                                                                             |
|        |                                                                                                    | NORMAL_STATE            | The timing reference is locked onto one of its provisioned references. The reference cannot be Internal or NO SYNC STATE.                                                                                                                                                                                                                                                     |
|        |                                                                                                    | FAST_START_STATE        | The node has switched references, but the reference is too far away to reach NORMAL_STATE within an acceptable amount of time. FAST_START_STATE is a fast acquisition mode to allow the node to quickly acquire the reference. After it achieves this goal, the node progresses to NORMAL_STATE.                                                                              |
|        |                                                                                                    | FAST_START_FAILED_STATE | A timing reference is too far away to reach in normal state. The FAST_START_STATE could not acquire sufficient timing information within the allowable amount of time.                                                                                                                                                                                                        |

Table 13-2 ONS 15454 Timing Report (continued)

| Item              | Description                                                                                   | Option                                                                  | Option Description                                                                                                             |
|-------------------|-----------------------------------------------------------------------------------------------|-------------------------------------------------------------------------|--------------------------------------------------------------------------------------------------------------------------------|
| Status Changed At | Date and time of the last status change.                                                      | —                                                                       | —                                                                                                                              |
| Switch Type       | Type of switch.                                                                               | AUTOMATIC                                                               | The timing switch was system-generated.                                                                                        |
|                   |                                                                                               | Manual                                                                  | The timing switch was a user-initiated Manual switch.                                                                          |
|                   |                                                                                               | Force                                                                   | The timing switch was user-initiated Force switch.                                                                             |
| Reference         | Indicates the timing reference.                                                               | Three timing references are available on the Provisioning > Timing tab. | —                                                                                                                              |
| Selected          | Indicates whether the reference is selected.                                                  | Selected references are indicated with an X.                            | —                                                                                                                              |
| Facility          | Indicates the timing facility provisioned for the reference on the Provisioning > Timing tab. | BITS-1                                                                  | The timing facility is a building integrated timing supply (BITS) clock attached to the node's BITS-1 pins.                    |
|                   |                                                                                               | BITS-2                                                                  | The timing facility is a BITS clock attached to the node's BITS-2 pins.                                                        |
|                   |                                                                                               | OC-N/STM-N card with port number                                        | If the node is set to line timing, this is the OC-N/STM-N card and port provisioned as the timing reference.                   |
|                   |                                                                                               | Internal clock                                                          | The node is using its internal clock.                                                                                          |
| State             | Indicates the timing reference state.                                                         | IS                                                                      | The timing reference is in service.                                                                                            |
|                   |                                                                                               | OOS                                                                     | The timing reference is out of service.                                                                                        |
| Condition         | Indicates the timing reference state.                                                         | OKAY                                                                    | The reference is valid to use as a timing reference.                                                                           |
|                   |                                                                                               | OOB                                                                     | Out of bounds; the reference is not valid and cannot be used as a timing reference, for example, a BITS clock is disconnected. |
| Condition Changed | Indicates the date and time of the last status change in MM/DD/YY HH:MM:SS format.            | —                                                                       | —                                                                                                                              |
| SSM               | Indicates whether SSM is enabled for the timing reference.                                    | Enabled                                                                 | SSM is enabled.                                                                                                                |
|                   |                                                                                               | Disabled                                                                | SSM is not enabled.                                                                                                            |

Table 13-2 ONS 15454 Timing Report (continued)

| Item        | Description                                                                            | Option                                           | Option Description                                                                                             |
|-------------|----------------------------------------------------------------------------------------|--------------------------------------------------|----------------------------------------------------------------------------------------------------------------|
| SSM Quality | Indicates the SSM timing quality.                                                      | 8 to 10 SSM quality messages might be displayed. | For a list of SSM message sets, see the “Timing” chapter in the <i>Cisco ONS 15454 DWDM Reference Manual</i> . |
| SSM Changed | Indicates the date and time of the last SSM status change in MM/DD/YY HH:MM:SS format. | —                                                | —                                                                                                              |

Stop. You have completed this procedure.

## NTP-G114 Inspect, Clean, and Replace the Air Filter

|                                |                                                                                                                                                          |
|--------------------------------|----------------------------------------------------------------------------------------------------------------------------------------------------------|
| <b>Purpose</b>                 | This procedure ensures that the air filter is free from dirt and dust, which allows optimum air flow and prevents dirt and dust from entering the shelf. |
| <b>Tools/Equipment</b>         | Vacuum or detergent and water faucet, spare filter, pinned hex key tool                                                                                  |
| <b>Prerequisite Procedures</b> | None                                                                                                                                                     |
| <b>Required/As Needed</b>      | As needed                                                                                                                                                |
| <b>Onsite/Remote</b>           | Onsite                                                                                                                                                   |
| <b>Security Level</b>          | None                                                                                                                                                     |



### Warning

**Do not reach into a vacant slot or chassis while you install or remove a module or a fan. Exposed circuitry could constitute an energy hazard.** Statement 206



### Caution

Cisco recommends that you inspect the air filter monthly, and clean the filter every three to six months. Replace the air filter every two to three years. Avoid cleaning the air filter with harsh cleaning agents or solvents.



### Note

Although the filter can work if it is installed with either side facing up, Cisco recommends that you install it with the metal bracing facing up to preserve the surface of the filter.

### Step 1

Verify that you are replacing a reusable air filter. The reusable filter is made of a gray, open-cell, polyurethane foam that is specially coated to provide fire and fungi resistance. NEBS 3E and later versions of the ONS 15454 use a reusable air filter.

- Step 2** If the air filter is installed in the external filter brackets, slide the filter out of the brackets while being careful not to dislodge any dust that might have collected on the filter and proceed to [Step 9](#). [Figure 13-4](#) shows the reusable fan-tray air filter in an external filter bracket on an ANSI shelf. [Figure 13-5](#) shows the reusable fan-tray air filter in an external filter bracket on an ETSI shelf.
- Step 3** If the filter is installed below the fan tray and not in the external filter brackets, open the front door of the shelf assembly. If the front door is already open, proceed to [Step 4](#).
- Open the front door lock.  
The ONS 15454 comes with a pinned hex key for locking and unlocking the front door. Turn the key counterclockwise to unlock the door and clockwise to lock it.
  - Press the door button to release the latch.
  - Swing the door open.
- Step 4** (Optional) Remove the front door using the “[DLP-G10 Remove the Front Door](#)” task on page 1-21. If you do not want to remove the door or it is already removed, proceed to [Step 5](#).

**Figure 13-4** ANSI Shelf Fan-Tray Air Filter in an External Filter Bracket (Front Door Removed)

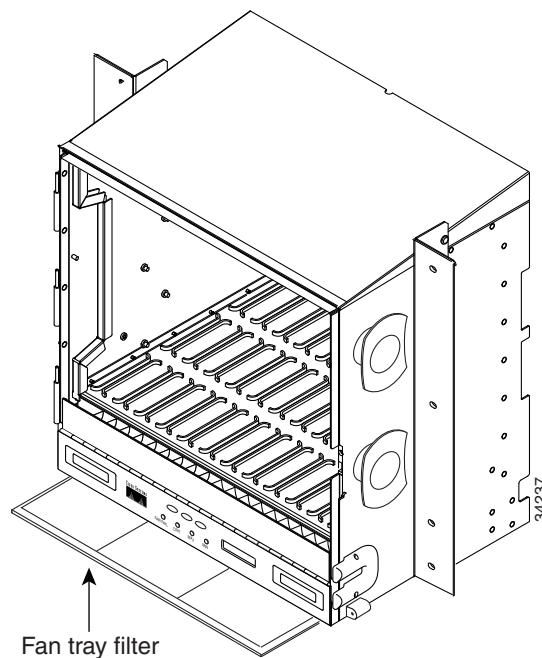

**Figure 13-5** ETSI Shelf Fan-Tray Air Filter in an External Filter Bracket (Front Door Removed)

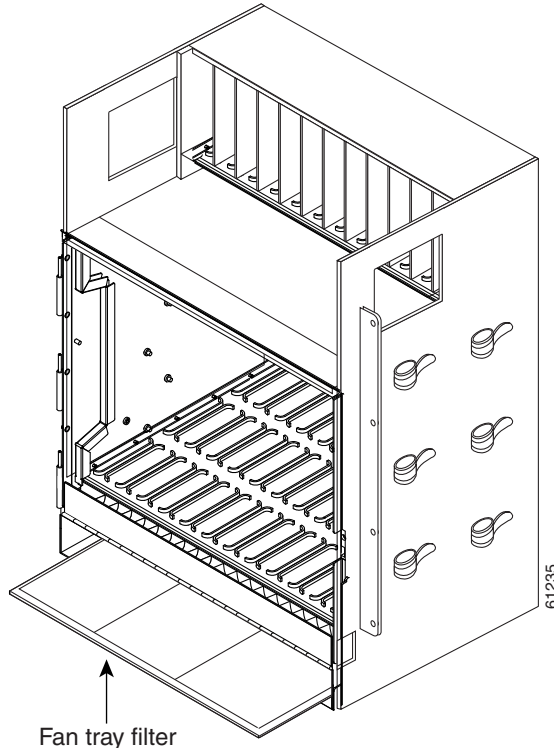

- Step 5** Push the outer side of the handles on the fan-tray assembly to expose the handles.
- Step 6** Pull the handles and slide the fan-tray assembly one inch (25.4 mm) out of the shelf assembly and wait until the fans stop.
- Step 7** When the fans have stopped, pull the fan-tray assembly completely out of the shelf assembly.
- Step 8** Gently remove the air filter from the shelf assembly. Be careful not to dislodge any dust that might have collected on the filter.
- Step 9** Visually inspect the air filter material for dirt and dust.
- Step 10** If the reusable air filter contains a concentration of dirt and dust, replace the dirty air filter with a clean air filter (spare filters should be kept in stock) and reinsert the fan-tray assembly. Then, vacuum the dirty air filter or wash it under a faucet with a light detergent.



**Caution**

Do not leave the fan tray out of the chassis for an extended period of time because excessive heat can damage the ONS 15454 cards.



**Note**

Cleaning should take place outside of the operating environment to avoid releasing dirt and dust near the equipment.

- Step 11** If you washed the filter, allow it to completely air dry for at least eight hours.



**Caution**

Do not put a damp filter back in the ONS 15454.

- Step 12** Replace the clean filter:
- If the air filter is installed in the external filter brackets, slide the dry air filter all the way to the back of the brackets to complete the procedure, continue to step 16.
  - If the filter is installed below the fan-tray assembly, remove the fan-tray assembly and slide the dry/clean air filter into the recessed compartment at the bottom of the shelf assembly. Put the front edge of the air filter flush against the front edge of the recessed compartment. Push the fan tray back into the shelf assembly.

**Caution**

If the fan tray does not slide all the way to the back of the shelf assembly, pull the fan tray out and readjust the position of the reusable filter until the fan tray fits correctly.

**Note**

On a powered-up ONS 15454, the fans start immediately after the fan-tray assembly is correctly inserted.

- Step 13** To verify that the tray is plugged into the backplane, ensure that the LCD on the front of the fan-tray assembly is activated and displays node information.
- Step 14** Rotate the retractable handles back into their compartments.
- Step 15** If you removed the door, complete the [“NTP-G40 Replace the Front Door” procedure on page 13-28](#). If not, close and lock the door.

**Stop. You have completed this procedure.**

## NTP-G115 Clean Fiber Connectors

|                                |                                                                                                                                                                                                    |
|--------------------------------|----------------------------------------------------------------------------------------------------------------------------------------------------------------------------------------------------|
| <b>Purpose</b>                 | This procedure cleans the fiber connectors.                                                                                                                                                        |
| <b>Tools/Equipment</b>         | <ul style="list-style-type: none"> <li>Inspection microscope</li> <li>Type A Fiber Optic Connector Cleaner (CLETOP reel)</li> <li>Optical swab</li> <li>Optical receiver cleaning stick</li> </ul> |
| <b>Prerequisite Procedures</b> | None                                                                                                                                                                                               |
| <b>Required/As Needed</b>      | Required                                                                                                                                                                                           |
| <b>Onsite/Remote</b>           | Onsite                                                                                                                                                                                             |
| <b>Security Level</b>          | None                                                                                                                                                                                               |

**Warning**

**Invisible laser radiation may be emitted from the end of the unterminated fiber cable or connector. Do not view directly with optical instruments. Viewing the laser output with certain optical instruments (for example, eye loupes, magnifiers, and microscopes) within a distance of 100 mm may pose an eye hazard.** Statement 1056

- Step 1** Using an inspection microscope, inspect each fiber connector for dirt, cracks, or scratches.
- Step 2** Replace any damaged fiber connectors.



---

**Note** Replace all dust caps whenever the equipment is unused for 30 minutes or more.

---

- Step 3** Complete the “DLP-G262 Clean Fiber Connectors with CLETOP” task on page 13-27 as necessary.
- Step 4** Complete the “DLP-G263 Clean the Fiber Adapters” task on page 13-27 as necessary.



---

**Note** To clean multi-fiber optic connectors, complete the “DLP-G261 Clean Multi Fiber-Optic Cable Connectors” task on page 13-26 as necessary.

---

**Stop. You have completed this procedure.**

---

## DLP-G261 Clean Multi Fiber-Optic Cable Connectors

|                                |                                                     |
|--------------------------------|-----------------------------------------------------|
| <b>Purpose</b>                 | This task cleans the multi fiber optic connectors   |
| <b>Tools/Equipment</b>         | Cleaning Cartridge for multi fiber optic connectors |
| <b>Prerequisite Procedures</b> | None                                                |
| <b>Required/As Needed</b>      | As needed                                           |
| <b>Onsite/Remote</b>           | Onsite                                              |
| <b>Security Level</b>          | None                                                |



**Warning**

---

**Invisible laser radiation may be emitted from the end of the unterminated fiber cable or connector. Do not stare into the beam or view directly with optical instruments.** Statement 1051

---

- Step 1** Remove the protective cap on the optical fiber cable connector.
- Step 2** Read the manufacturer (cleaning cartridge) instructions to insert the connector into the cleaning cartridge.
- Step 3** Slide the lever on the cartridge to swipe the connector surface.
- Step 4** Insert the fiber connector into the applicable adapter or attach a dust cap to the fiber connector.



---

**Note** If you must replace a dust cap on a connector, first verify that the dust cap is clean.

---

- Step 5** Return to your originating procedure (NTP).
-



## DLP-G262 Clean Fiber Connectors with CLETOP

|                                |                                                                                       |
|--------------------------------|---------------------------------------------------------------------------------------|
| <b>Purpose</b>                 | This task cleans the fiber connectors with CLETOP.                                    |
| <b>Tools/Equipment</b>         | Type A Fiber Optic Connector Cleaner (CLETOP reel)<br>Optical receiver cleaning stick |
| <b>Prerequisite Procedures</b> | None                                                                                  |
| <b>Required/As Needed</b>      | Required                                                                              |
| <b>Onsite/Remote</b>           | Onsite                                                                                |
| <b>Security Level</b>          | None                                                                                  |

- 
- Step 1** Remove the dust cap from the fiber connector.
- Step 2** Press the lever up to open the shutter door. Each time you press the lever, you expose a clean wiping surface.
- Step 3** Insert the connector into the CLETOP cleaning cassette slot, rotate one quarter turn, and gently swipe downwards.
- Step 4** Use an inspection microscope to inspect each fiber connector for dirt, cracks, or scratches. If the connector is not clean, repeat Steps 1 to 3.
- Step 5** Insert the fiber connector into the applicable adapter or attach a dust cap to the fiber connector.



**Note** If you must replace a dust cap on a connector, first verify that the dust cap is clean. To clean the dust cap, wipe the outside of the cap using a dry, lint-free wipe and the inside of the dust cap using a CLETOP stick swab (14100400).

- 
- Step 6** Return to your originating procedure (NTP).
- 

## DLP-G263 Clean the Fiber Adapters

|                                |                                      |
|--------------------------------|--------------------------------------|
| <b>Purpose</b>                 | This task cleans the fiber adapters. |
| <b>Tools/Equipment</b>         | CLETOP stick swab                    |
| <b>Prerequisite Procedures</b> | None                                 |
| <b>Required/As Needed</b>      | Required                             |
| <b>Onsite/Remote</b>           | Onsite                               |
| <b>Security Level</b>          | None                                 |

- 
- Step 1** Remove the dust plug from the fiber adapter.
- Step 2** Insert a CLETOP stick swab (14100400) into the adapter opening and rotate the swab.
- Step 3** Place dust plugs on the fiber adapters when not in use.
- Step 4** Return to your originating procedure (NTP).
-

# NTP-G40 Replace the Front Door

|                                |                                                                                                             |
|--------------------------------|-------------------------------------------------------------------------------------------------------------|
| <b>Purpose</b>                 | This procedure replaces the front door and door ground strap after installing cards and fiber-optic cables. |
| <b>Tools/Equipment</b>         | #2 Phillips screwdriver<br>Medium slot-head screwdriver<br>Small slot-head screwdriver                      |
| <b>Prerequisite Procedures</b> | <a href="#">NTP-G3 Open and Remove the Front Door</a> , page 1-20                                           |
| <b>Required/As Needed</b>      | Required                                                                                                    |
| <b>Onsite/Remote</b>           | Onsite                                                                                                      |
| <b>Security Level</b>          | None                                                                                                        |

**Note**

Be careful not to crimp any fiber cables that are connected to the MXP/TXP cards or DWDM cards. Some might not have the fiber boot attached.

- Step 1** Insert the front door into the hinges on the shelf assembly.
- Step 2** (ANSI only) Attach one end of the ground strap terminal lug (72-3622-01) to the male stud on the inside of the door. Attach and tighten the #6 Kepnut (49-0600-01) using the open-end wrench ([Figure 13-6](#)).

**Figure 13-6** Installing the Door Ground Strap Retrofit Kit

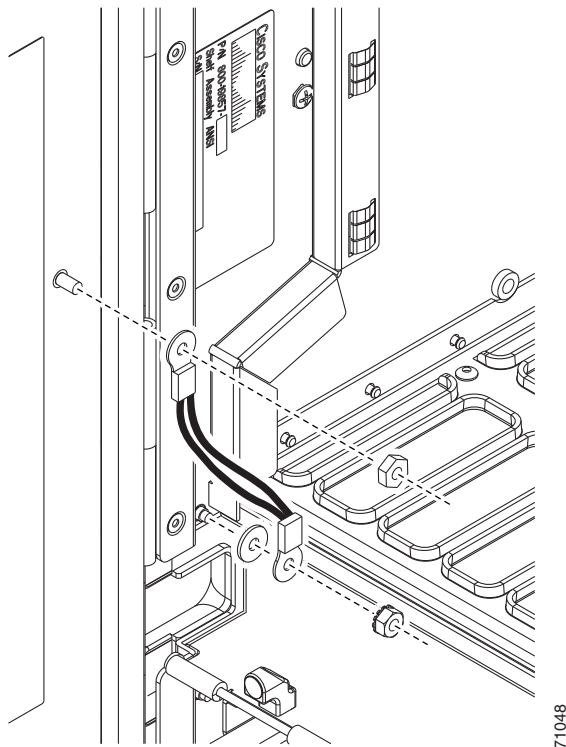

- Step 3** (ANSI only) Attach the other end of the ground strap to the longer screw on the fiber guide.
- Attach the lock washer.

- b. Attach the terminal lug.
- c. Using the open-end wrench, attach and tighten the #4 Kepnut (49-0337-01) on the terminal lug.



**Note** To avoid interference with the traffic (line) card, make sure the ground strap is in a flat position when the door is open. To move the ground strap into a flat position, rotate the terminal lug counterclockwise before tightening the Kepnut.

**Step 4** Replace the left cable-routing channel if it was removed. If not, continue with [Step 5](#).

**Step 5** Using a Phillips screwdriver, insert and tighten the screws for the cable-routing channel.

[Figure 13-7](#) shows the shelf assembly with the front door and ground strap installed.

**Figure 13-7 Shelf Assembly with Door Ground Strap Retrofit Kit Installed (ANSI)**

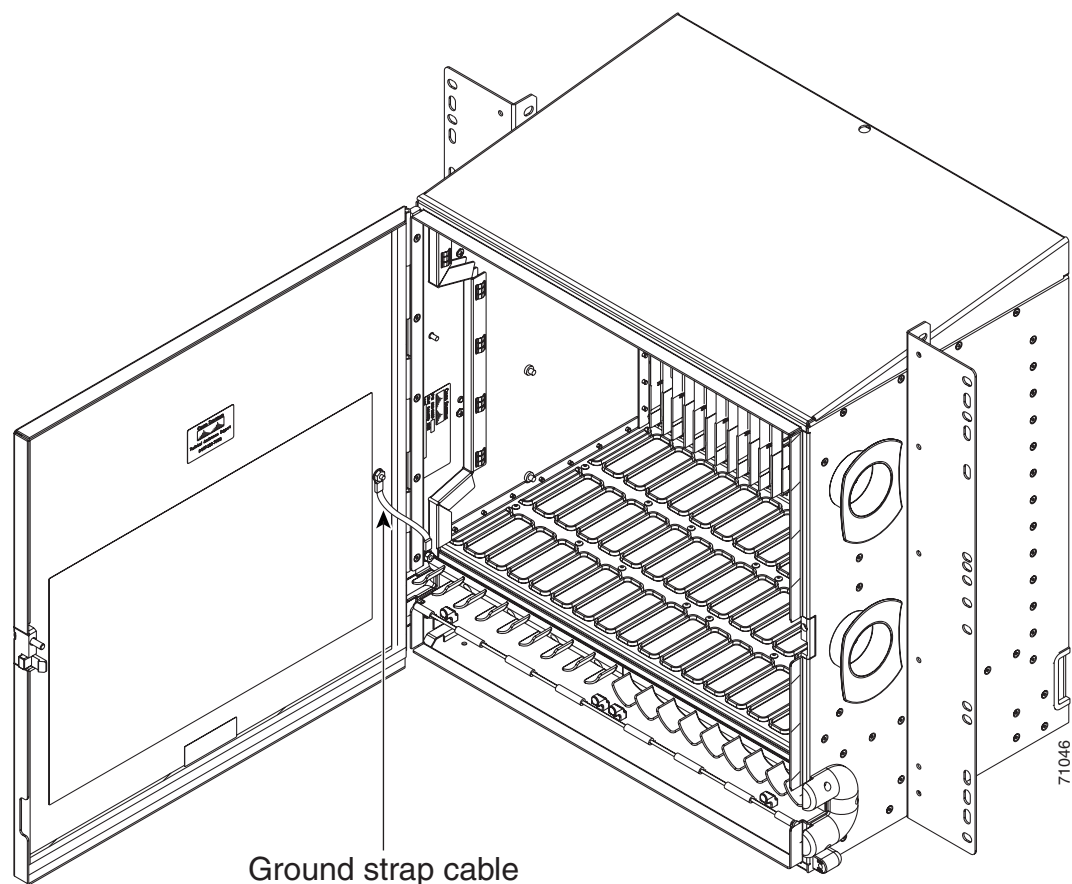

**Step 6** Swing the door closed and lock the door with the provided pinned-hex key. Turn the key clockwise to lock the door; counterclockwise to unlock it.

**Stop. You have completed this procedure.**

# NTP-G116 Replace the Fan-Tray Assembly

|                                |                                                             |
|--------------------------------|-------------------------------------------------------------|
| <b>Purpose</b>                 | This procedure replaces a malfunctioning fan-tray assembly. |
| <b>Tools/Equipment</b>         | None                                                        |
| <b>Prerequisite Procedures</b> | <a href="#">NTP-G8 Install the Fan-Tray Assembly</a>        |
| <b>Required/As Needed</b>      | As needed                                                   |
| <b>Onsite/Remote</b>           | Onsite                                                      |
| <b>Security Level</b>          | None                                                        |

**Caution**

The 15454-FTA3 fan-tray assembly can only be installed in ONS 15454 R3.1 and later shelf assemblies (15454-SA-ANSI, P/N: 800-19857; 15454-SA-HD, P/N: 800-24848). The fan-tray assembly includes a pin that prevents it from being installed in ONS 15454 shelf assemblies released before ONS 15454 R3.1 (15454-SA-NEBS3E, 15454-SA-NEBS3, and 15454-SA-R1, P/N: 800-07149). Equipment damage can result from attempting to install the 15454-FTA3 in a incompatible shelf assembly.

**Caution**

Do not force a fan-tray assembly into place. Doing so can damage the connectors on the fan tray and/or the connectors on the backplane.

**Note**

To replace the fan-tray assembly, it is not necessary to move any of the cable management facilities.

**Step 1**

Review [Table 13-3](#) (ANSI) or [Table 13-4](#) (ETSI) to ensure that you have compatible components when replacing the fan-tray assembly. Note the alarms that will be generated when an incompatibility occurs.



**Note** If you need to determine the hardware that has been installed on a node, click the Inventory tab in node view.

**Table 13-3 Incompatibility Alarms for ONS 15454 ANSI**

| Shelf Assembly <sup>1</sup> | Fan Tray <sup>2</sup> | AIP <sup>3</sup> | 10G Cards <sup>4</sup> | Ethernet Cards <sup>5</sup> | Alarms                                                                    |
|-----------------------------|-----------------------|------------------|------------------------|-----------------------------|---------------------------------------------------------------------------|
| —                           | —                     | No fuse          | —                      | —                           | Mismatch of equipment attributes (MEA) on the alarm interface panel (AIP) |
| NEBS3E or NEBS3             | 2A                    | 2A               | No                     | —                           | None                                                                      |
| NEBS3E or NEBS3             | 2A                    | 2A               | Yes                    | —                           | MEA on 10G                                                                |
| NEBS3E or NEBS3             | 2A                    | 5A               | No                     | —                           | None                                                                      |
| NEBS3E or NEBS3             | 2A                    | 5A               | Yes                    | —                           | MEA on 10G                                                                |
| ANSI or HD                  | 2A                    | 2A               | No                     | —                           | None                                                                      |
| ANSI or HD                  | 2A                    | 2A               | Yes                    | 2.5G compatible             | MEA on fan tray, AIP, and Ethernet                                        |

**Table 13-3 Incompatibility Alarms for ONS 15454 ANSI (continued)**

| Shelf Assembly <sup>1</sup> | Fan Tray <sup>2</sup> | AIP <sup>3</sup> | 10G Cards <sup>4</sup> | Ethernet Cards <sup>5</sup> | Alarms                       |
|-----------------------------|-----------------------|------------------|------------------------|-----------------------------|------------------------------|
| ANSI or HD                  | 2A                    | 2A               | Yes                    | 10G compatible              | MEA on fan tray and AIP      |
| ANSI or HD                  | 2A                    | 5A               | No                     | Either                      | None                         |
| ANSI or HD                  | 2A                    | 5A               | Yes                    | 2.5G compatible             | MEA on fan tray and Ethernet |
| ANSI or HD                  | 2A                    | 5A               | Yes                    | 10G compatible              | MEA on fan tray              |
| ANSI or HD                  | 5A                    | 2A               | No                     | Either                      | MEA on AIP                   |
| ANSI or HD                  | 5A                    | 2A               | Yes                    | 2.5G compatible             | MEA on AIP and Ethernet      |
| ANSI or HD                  | 5A                    | 2A               | Yes                    | 10G compatible              | MEA on AIP                   |
| ANSI or HD                  | 5A                    | 5A               | No                     | Either                      | None                         |
| ANSI or HD                  | 5A                    | 5A               | Yes                    | Either                      | None                         |

- 15454-SA-NEBS3E (P/N: 800-07149-xx) or 15454-SA-NEBS3 (P/N: 800-06741-xx) = shelf assemblies released before ONS 15454 Release 3.1  
15454-SA-ANSI (P/N: 800-19857-01) = ONS 15454 Release 3.1 and later shelf assembly  
15454-SA-HD (P/N: 800-24848) = ONS 15454 Release 3.1 and later shelf assembly
- 5A Fan Tray = 15454-FTA3 (P/N: 800-19858-xx) or 15454-FTA3-T (P/N: 800-21448-xx)  
2A Fan Tray = 15454-FTA2 (P/Ns: 800-07145-xx, 800-07385-xx, 800-19591-xx, 800-19590-xx)
- 5A AIP (P/N: 73-7665-01), 2A AIP (P/N: 73-5262-01)
- 10G cards include the XC10G, OC192, and OC48AS.
- 2.5G compatible indicates cards that are compatible with the XCVT cross-connect card. 10G compatible indicates cards that are compatible with the XC10G and XC-VXC-10G cross-connect cards.

**Table 13-4 Incompatibility Alarms for ONS 15454 ETSI**

| Shelf Assembly <sup>1</sup> | Fan Tray <sup>2</sup> | 10G Cards <sup>3</sup> | Ethernet Cards  | Alarms                        |
|-----------------------------|-----------------------|------------------------|-----------------|-------------------------------|
| 15454E-SA-ETSI              | 2A                    | No                     | —               | None                          |
| 15454E-SA-ETSI              | 2A                    | Yes                    | —               | MEA on 10G                    |
| 15454E-SA-ETSI              | 2A                    | No                     | —               | None                          |
| 15454E-SA-ETSI              | 2A                    | Yes                    | —               | MEA on 10G                    |
| 15454E-SA-ETSI              | 5A                    | No                     | —               | MEA on fan tray               |
| 15454E-SA-ETSI              | 5A                    | Yes                    | —               | MEA on fan tray and 10G cards |
| 15454E-SA-ETSI              | 5A                    | No                     | —               | None                          |
| 15454E-SA-ETSI              | 5A                    | Yes                    | —               | MEA on 10G                    |
| ETSI                        | 2A                    | No                     | —               | None                          |
| ETSI                        | 2A                    | Yes                    | 2.5G compatible | MEA on fan tray or Ethernet   |
| ETSI                        | 2A                    | Yes                    | 10G compatible  | MEA on fan tray               |
| ETSI                        | 2A                    | No                     | Either          | None                          |
| ETSI                        | 2A                    | Yes                    | 2.5G compatible | MEA on fan tray, Ethernet     |

**Table 13-4** Incompatibility Alarms for ONS 15454 ETSI (continued)

| Shelf Assembly <sup>1</sup> | Fan Tray <sup>2</sup> | 10G Cards <sup>3</sup> | Ethernet Cards  | Alarms          |
|-----------------------------|-----------------------|------------------------|-----------------|-----------------|
| ETSI                        | 2A                    | Yes                    | 10G compatible  | MEA on fan tray |
| ETSI                        | 5A                    | Yes                    | 2.5G compatible | MEA on Ethernet |
| ETSI                        | 5A                    | No                     | Either          | None            |
| ETSI                        | 5A                    | Yes                    | Either          | None            |

1. 15454-SA-ETSI (P/N: 800-08708-XX) = ONS 15454 SDH Release 3.3 and later shelf assembly

2. 5A Fan Tray = 15454E-FTA-60V  
2A Fan Tray = 15454E-FTA-48V

3. 10G cards = XC10G, XC-VXL-10G, XC-VXC-10G

- Step 2** Open the front door of the shelf assembly. If the shelf assembly does not have a front door, continue with [Step 4](#).
- a. Open the front door lock.  
The ONS 15454 comes with a pinned hex key for locking and unlocking the front door. Turn the key counterclockwise to unlock the door and clockwise to lock it.
  - b. Press the door button to release the latch.
  - c. Swing the door open.
- Step 3** (Optional) Complete the “[DLP-G10 Remove the Front Door](#)” task on page 1-21 to remove the front door. If you do not want to remove the door, proceed to [Step 4](#).
- Step 4** Push the outer side of the handles on the fan-tray assembly to expose the handles.
- Step 5** Fold out the retractable handles at the outside edges of the fan tray.
- Step 6** Pull the handles and slide the fan-tray assembly one inch (25.4 mm) out of the shelf assembly and wait until the fans stop.
- Step 7** When the fans have stopped, pull the fan-tray assembly completely out of the shelf assembly. [Figure 13-8](#) shows the location of the fan tray on the ONS 15454 ANSI shelf.

Figure 13-8 Removing or Replacing the Fan-Tray Assembly (Front Door Removed) (ANSI)

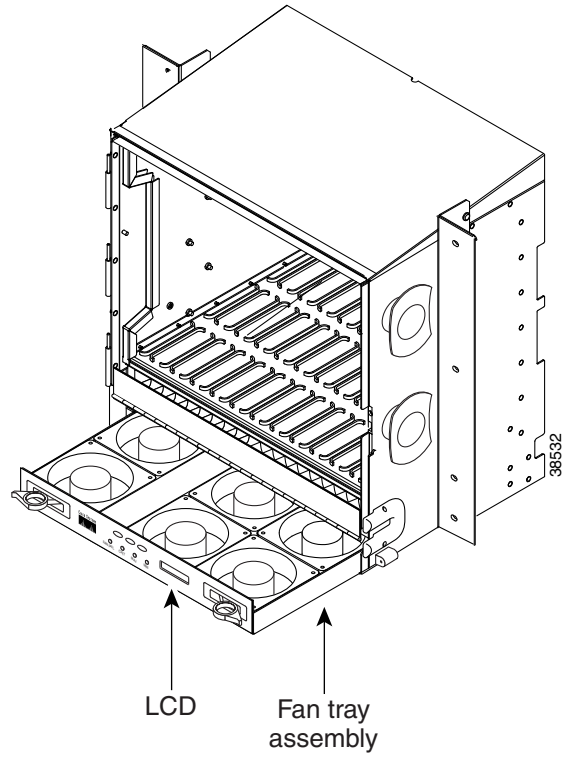
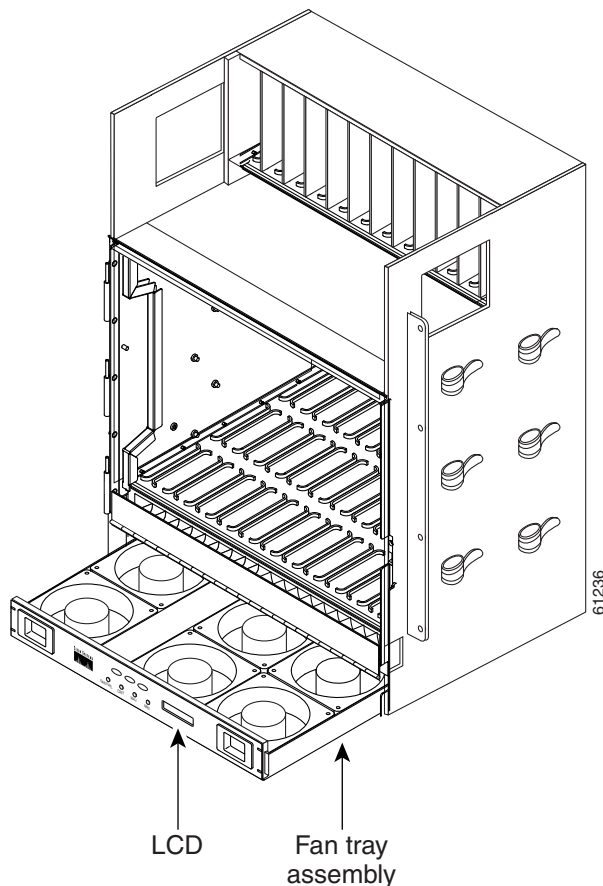

Figure 13-9 shows the location of the fan tray on the ONS 15454 ETSI shelf.

**Figure 13-9** Removing or Replacing the Fan-Tray Assembly (Front Door Removed) (ETSI)



- Step 8** If you are replacing the fan-tray air filter and it is installed beneath the fan-tray assembly, slide the existing air filter out of the shelf assembly and replace it before replacing the fan-tray assembly.
- If you are replacing the fan-tray air filter and it is installed in the external bottom bracket (ANSI shelf only), you can slide the existing air filter out of the bracket and replace it at anytime. For more information on the fan-tray air filter, see the [“NTP-G114 Inspect, Clean, and Replace the Air Filter” procedure on page 13-22](#).
- Step 9** Slide the new fan tray into the shelf assembly until the electrical plug at the rear of the tray plugs into the corresponding receptacle on the backplane.
- Step 10** To verify that the tray has plugged into the backplane, ensure that the LCD on the front of the fan tray is activated.
- Step 11** If you removed the door, complete the [“NTP-G40 Replace the Front Door” procedure on page 13-28](#).
- Stop. You have completed this procedure.**



# NTP-G117 Replace the ANSI Shelf Alarm Interface Panel

|                                |                                                                       |
|--------------------------------|-----------------------------------------------------------------------|
| <b>Purpose</b>                 | This procedure replaces the AIP on the ONS 15454 ANSI shelf assembly. |
| <b>Tools/Equipment</b>         | #2 Phillips screwdriver                                               |
| <b>Prerequisite Procedures</b> | None                                                                  |
| <b>Required/As Needed</b>      | As needed                                                             |
| <b>Onsite/Remote</b>           | Onsite or remote                                                      |
| <b>Security Level</b>          | Provisioning or higher                                                |

**Caution**

Do not use a 2A AIP with a 5A fan-tray assembly; doing so will cause a blown fuse on the AIP.

**Caution**

Always use the supplied ESD wristband when working with a powered ONS 15454. Plug the wristband cable into the ESD jack located on the lower-right outside edge of the shelf assembly.

**Caution**

Do not perform this procedure on a node with live traffic. Hot-swapping the AIP can affect traffic and result in a loss of data. For assistance with AIP replacement, contact the Cisco TAC. See the [“Obtaining Documentation and Submitting a Service Request”](#) section on page iv.

- Step 1** Review [Table 13-3 on page 13-30](#) to ensure that you have compatible components when replacing the ANSI shelf AIP and note the alarms that will occur when an incompatibility occurs.
- Step 2** Ensure that all nodes in the affected network are running the same software version before replacing the AIP and repairing circuits:
- In network view or multishelf view (multishelf mode), click, click the **Maintenance > Software** tabs. The working software version for each node is listed in the Working Version column.
  - If you need to upgrade the software on a node, refer to the release-specific software upgrade document. No hardware should be changed or circuit repair performed until after the software upgrade is complete. If you do not need to upgrade software or have completed the software upgrade, proceed to [Step 3](#).
- Step 3** Record the MAC address of the old AIP:
- Log into the node where you will replace the AIP. See the [“DLP-G46 Log into CTC”](#) task on [page 2-25](#).
  - In node view (single-shelf mode) or multishelf view (multishelf mode), click the **Provisioning > Network** tabs.
  - Record the MAC address shown in the General tab ([Figure 13-10](#)).

Figure 13-10 Find the MAC Address

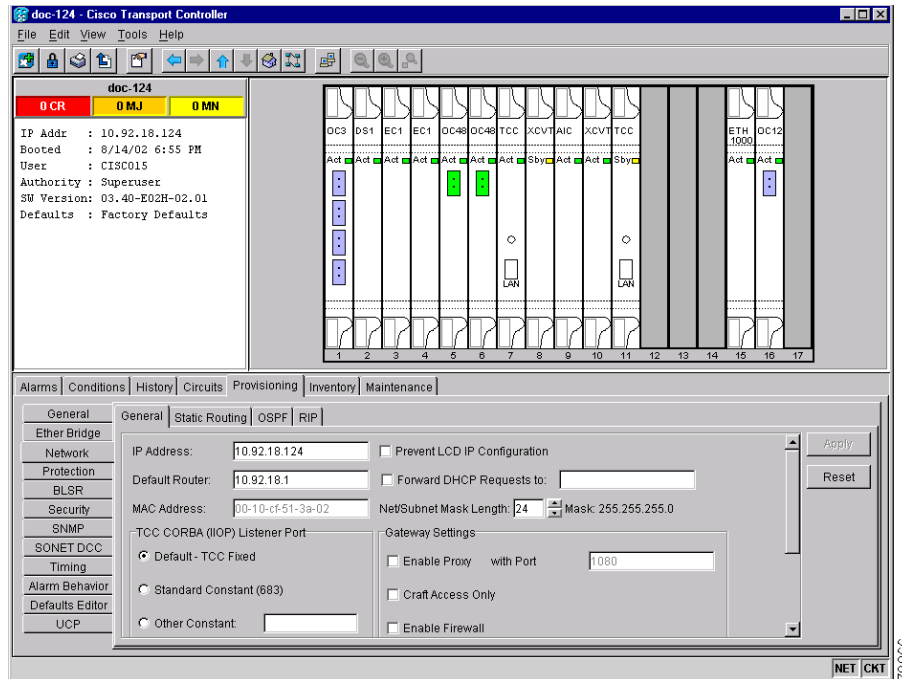

- Step 4** Call Cisco TAC for assistance in replacing the AIP and maintaining the original MAC address. See the “Obtaining Documentation and Submitting a Service Request” section on page Iv.
- Step 5** Complete the “DLP-G13 Remove the Lower Backplane Cover” task on page 1-27.
- Step 6** Unscrew the two screws that hold the AIP cover in place.
- Step 7** Grip the cover and gently pull away from the backplane.



**Note** On the 15454-SA-HD (P/N: 800-24848), 15454-SA-NEBS3E, 15454-SA-NEBS3, and 15454-SA-R1 (P/N: 800-07149) shelves, the AIP cover is clear plastic. On the 15454-SA-ANSI shelf (P/N: 800-19857), the AIP cover is metal.

- Step 8** Grip the AIP and gently pull it away from the backplane.
- Step 9** Disconnect the fan-tray assembly power cable from the AIP.
- Step 10** Set the old AIP aside for return to Cisco.

**Caution**

The type of shelf that the AIP resides in determines the version of AIP that should replace the failed AIP. The 15454-SA-ANSI shelf (P/N: 800-19857) and 15454-SA-HD (P/N: 800-24848) currently use the 5A AIP, (P/N: 73-7665-01). The 15454-SA-NEBS3E, 15454-SA-NEBS3, and 15454-SA-R1 (P/N: 800-07149) shelves and earlier use the 2A AIP (P/N: 73-5262-01).

**Caution**

Do not put a 2A AIP (P/N: 73-5262-01) into a 15454-SA-ANSI (P/N: 800-19857) or 15454-SA-HD (P/N: 800-24848) shelf; doing so will cause a blown fuse on the AIP.

- Step 11** Attach the fan-tray assembly power cable to the new AIP.

- Step 12** Place the new AIP on the backplane by plugging the panel into the backplane using the DIN connector.
- Step 13** Replace the AIP cover over the AIP and secure the cover with the two screws.
- Step 14** Replace the lower backplane cover and secure the cover with the five screws.
- Step 15** In node view (single-shelf mode) or multishelf view (multishelf mode), click the **Provisioning > Network** tabs.

**Caution**

Cisco recommends that TCC2/TCC2P card resets be performed in a maintenance window to avoid any potential service disruptions.

- Step 16** Reset the standby TCC2/TCC2P card:
- Right-click the standby TCC2/TCC2P card and choose **Reset Card**.
  - Click **Yes** in the Resetting Card dialog box. As the card resets, a loading (Ldg) indication appears on the card in CTC.

**Note**

The reset takes approximately five minutes. Do not perform any other steps until the reset is complete.

- Step 17** Complete the [“DLP-G250 Reset the TCC2/TCC2P Card” task on page 13-12](#) to reset the active TCC2/TCC2P card.
- Step 18** From the **File** drop-down list, choose **Exit** to exit the CTC session.
- Step 19** Log back into the node. In the Login dialog box, choose **(None)** from the Additional Nodes drop-down list.
- Step 20** Record the new MAC address:
- In node view (single-shelf mode) or multishelf view (multishelf mode), click the **Provisioning > Network** tabs.
  - Record the MAC address shown in the General tab.
- Step 21** In node view (single-shelf mode) or multishelf view (multishelf mode), click the **Circuits** tab. Note that all circuits listed have a status of PARTIAL.
- Step 22** In node view (single-shelf mode) or multishelf view (multishelf mode), choose **Repair Circuits** from the **Tools** drop-down list. The Circuit Repair dialog box appears.
- Step 23** Read the instructions in the Circuit Repair dialog box ([Figure 13-11](#)). If all the steps in the dialog box have been completed, click **Next**. Ensure that you have the old and new MAC addresses.

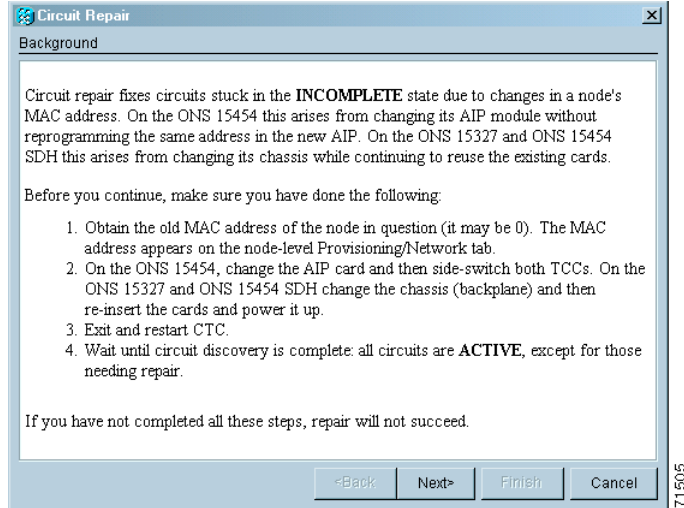
**Figure 13-11** Repairing Circuits

- Step 24** The Node MAC Addresses dialog box appears (Figure 13-12):
- From the Node drop-down list, choose the name of the node where you replaced the AIP.
  - In the Old MAC Address field, enter the old MAC address that was recorded in Step 3.
  - Click **Next**.

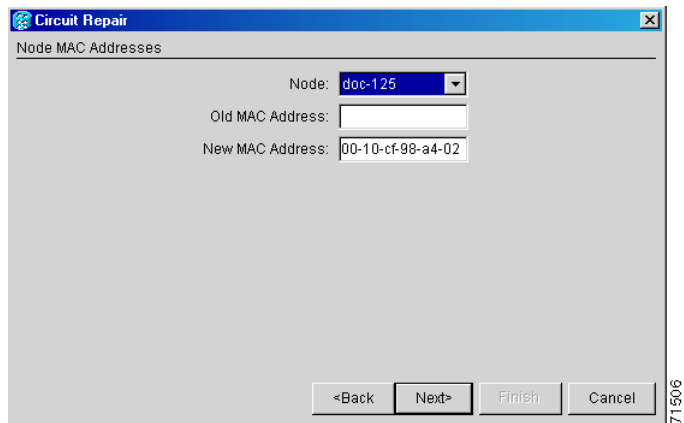
**Figure 13-12** Recording the Old MAC Address Before Replacing the AIP

- Step 25** The Repair Circuits dialog box appears (Figure 13-13). Read the information in the dialog box and click **Finish**.

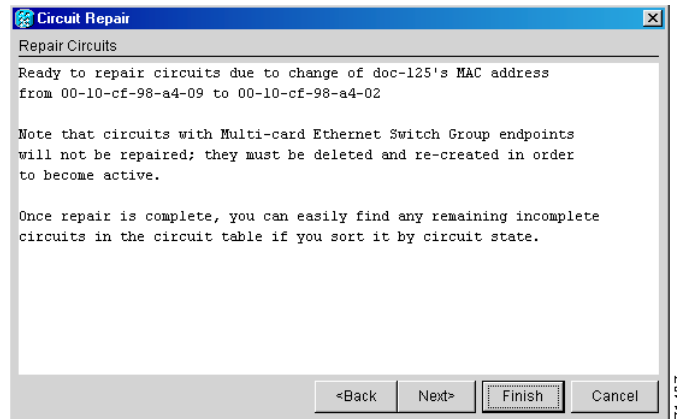
**Figure 13-13** Circuit Repair Information

**Note** The CTC session freezes until all circuits are repaired. Circuit repair can take up to five minutes or more depending on the number of circuits provisioned.

When the circuit repair is complete, the Circuits Repaired dialog box appears.

**Step 26** Click **OK**.

**Step 27** In node view of the new node, click the **Circuits** tab. Check to ensure that all circuits listed have a status of **DISCOVERED**. If all circuits listed are not **DISCOVERED**, call the Cisco TAC at (800) 553-2447 to open a Return Material Authorization (RMA).

**Stop. You have completed this procedure.**

## NTP-G118 Replace the ANSI Shelf Plastic Lower Backplane Cover

|                                |                                                                                                                        |
|--------------------------------|------------------------------------------------------------------------------------------------------------------------|
| <b>Purpose</b>                 | This procedure replaces the metal cover with the plastic cover located at the bottom rear of the ONS 15454 ANSI shelf. |
| <b>Tools/Equipment</b>         | Phillips screwdriver                                                                                                   |
| <b>Prerequisite Procedures</b> | None                                                                                                                   |
| <b>Required/As Needed</b>      | As needed                                                                                                              |
| <b>Onsite/Remote</b>           | Onsite                                                                                                                 |
| <b>Security Level</b>          | None                                                                                                                   |

**Step 1** Use the Phillips screwdriver to unscrew the five retaining screws that hold the metal cover in place.

**Step 2** Grasp the metal cover on each side.

**Step 3** Gently pull the metal cover away from the backplane.

**Step 4** Place the plastic cover against the shelf assembly and align the screw holes on the cover and the shelf assembly (Figure 13-14).

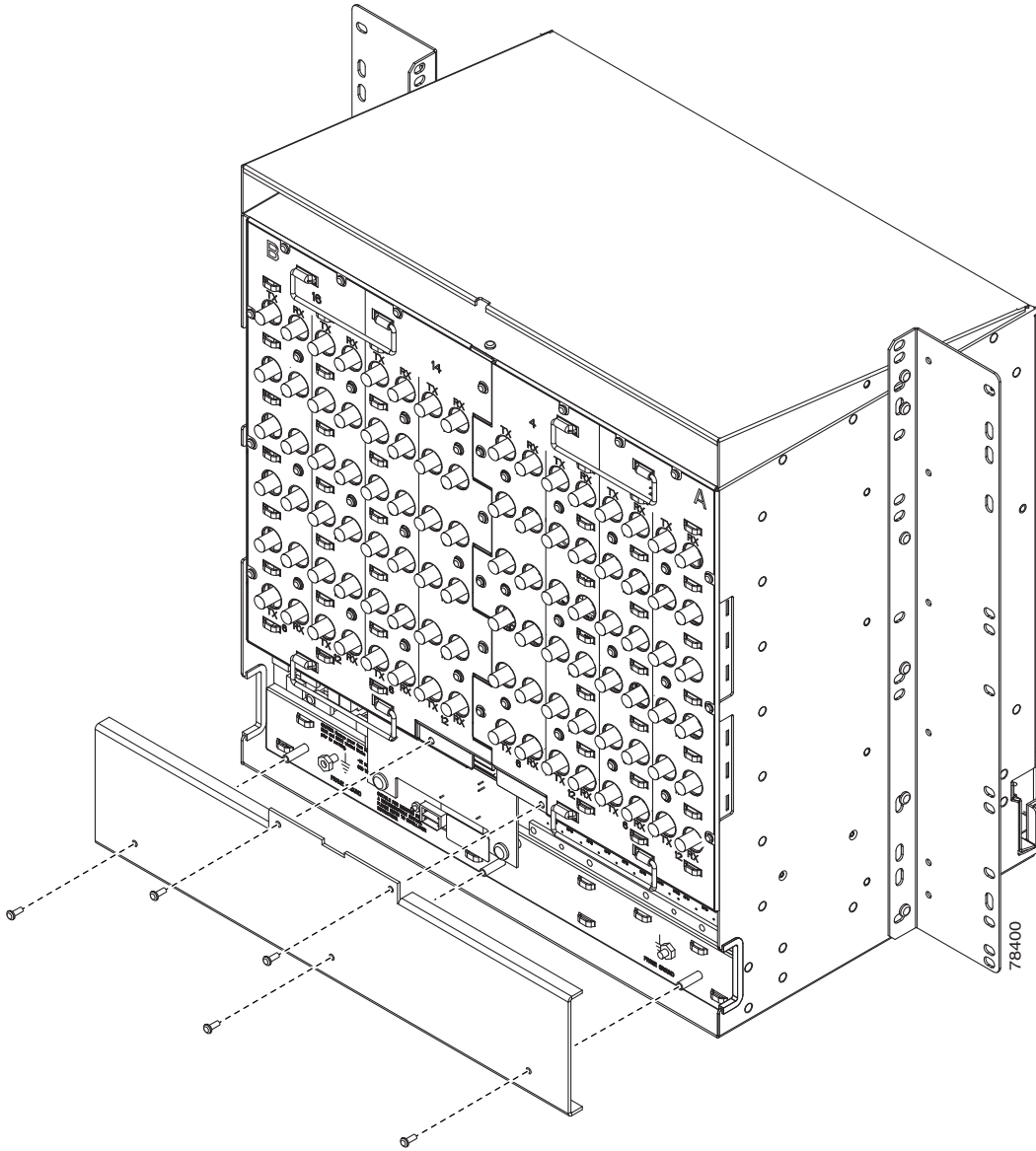
**Figure 13-14** Attaching Plastic Lower Backplane Cover

- Step 5** Tighten the five retaining screws that hold the plastic cover in place.  
**Stop. You have completed this procedure.**
-

# NTP-G135 Edit Network Element Defaults

|                                |                                                                                                                                                                                                                       |
|--------------------------------|-----------------------------------------------------------------------------------------------------------------------------------------------------------------------------------------------------------------------|
| <b>Purpose</b>                 | This procedure edits the factory-configured NE defaults using the NE Defaults editor. The new defaults can be applied to the node where they are edited, or exported to a file to be imported for use on other nodes. |
| <b>Tools/Equipment</b>         | None                                                                                                                                                                                                                  |
| <b>Prerequisite Procedures</b> | None                                                                                                                                                                                                                  |
| <b>Required/As Needed</b>      | As needed                                                                                                                                                                                                             |
| <b>Onsite/Remote</b>           | Onsite or remote                                                                                                                                                                                                      |
| <b>Security Level</b>          | Superuser                                                                                                                                                                                                             |



**Note** For a list of NE defaults, see the “Network Element Defaults” appendix in the *Cisco ONS 15454 DWDM Reference Manual*.

- 
- Step 1** Complete the “[DLP-G46 Log into CTC](#)” task on page 2-25 at the node where you want to edit NE defaults.
- Step 2** In node view (single-shelf mode) or multishelf view (multishelf mode), click the **Provisioning > Defaults** tabs. Wait for the Defaults selector frame to load the defaults. This could take several minutes.
- Step 3** Under Defaults Selector, choose either a card (if editing card-level defaults) or NODE (if editing node-level defaults). Clicking on the node name (at the top of the Defaults Selector column) lists all available NE defaults (both node- and card-level) under Default Name.
- Step 4** Locate a default that you want to change under Default Name.
- Step 5** Click in the **Default Value** column for the default property that you are changing and either choose a value from the drop-down list (when available), or type in the desired new value.



**Note** If you click **Reset** before you click **Apply**, all values will return to their original settings.

- Step 6** Click **Apply** (click in the **Default Name** column to activate the Apply button if it is unavailable). You can modify multiple default values before applying the changes.
- A pencil icon will appear next to any default value that will be changed as a result of editing the defaults file.
- Step 7** If you are modifying node-level defaults, a dialog box appears telling you that defaults were successfully applied to the node. Click **Yes**.
- If you are modifying the IIOP Listener Port setting, a dialog box appears warning you that the node will reboot and asks if you want to continue. Click **Yes**.



**Note** Changes to most node defaults reprovision the node when you click Apply. Changes made to card settings using the Defaults Editor do not change the settings for cards that are already installed or slots that are preprovisioned for cards, but rather, change only cards that are installed or preprovisioned thereafter. To change settings for installed cards or preprovisioned slots, see [Chapter 11, “Change DWDM Card Settings.”](#) To change settings for transponder or muxponder cards see [Chapter 5, “Provision Transponder and Muxponder Cards.”](#)



**Note** Changing some NE defaults can cause CTC disconnection or a reboot of the node in order for the default to take effect. Before you change a default, view the Side Effects column of the Defaults editor (right-click a column header and select **Show Column > Side Effects**) and be prepared for the occurrence of any side effects listed for that default.

**Stop. You have completed this procedure.**

## NTP-G136 Import Network Element Defaults

|                                |                                                                                                                                                                                                                |
|--------------------------------|----------------------------------------------------------------------------------------------------------------------------------------------------------------------------------------------------------------|
| <b>Purpose</b>                 | This procedure imports the NE defaults using the NE Defaults editor. The defaults can either be imported from the CTC software CD (factory defaults) or from a customized file exported and saved from a node. |
| <b>Tools/Equipment</b>         | None                                                                                                                                                                                                           |
| <b>Prerequisite Procedures</b> | None                                                                                                                                                                                                           |
| <b>Required/As Needed</b>      | As needed                                                                                                                                                                                                      |
| <b>Onsite/Remote</b>           | Onsite or remote                                                                                                                                                                                               |
| <b>Security Level</b>          | Superuser                                                                                                                                                                                                      |



**Note** For a list of NE defaults, refer to the “Network Element Defaults” appendix in the *Cisco ONS 15454 DWDM Reference Manual*.

- Step 1** Complete the “[DLP-G46 Log into CTC](#)” task on page 2-25 at the node where you want to import NE defaults.
- Step 2** In node view (single-shelf mode) or multishelf view (multishelf mode), click the **Provisioning > Defaults** tabs.
- Step 3** Click **Import**.
- Step 4** If the correct file name and location of the desired file do not appear in the Import Defaults from File dialog box, click **Browse** and browse to the file that you are importing.
- Step 5** When the correct file name and location appear in the dialog box, click **OK**. If you are importing the factory defaults, the correct file name is 15454-defaults.txt for ANSI shelves and 15454SDH-defaults.txt for ETSI shelves.  
A pencil icon will appear next to any default value that will be changed as a result of importing the new defaults file.
- Step 6** Click **Apply**.
- Step 7** If the imported file fails to pass all edits, the problem field shows the first encountered problem default value that must be fixed. Change the problem default value and click **Apply**. Repeat until the imported file passes all edits successfully.
- Step 8** If you are modifying node-level defaults, a dialog box appears telling you that defaults were successfully applied to the node. Click **Yes**.
- Step 9** If you are modifying the IIOP Listener Port setting, a dialog box appears warning you that the node will reboot and asks if you want to continue. Click **Yes**.





**Note** Changes to most node defaults reprovision the node when you click Apply. Changes made to card settings using the Defaults Editor do not change the settings for cards that are already installed or slots that are preprovisioned for cards, but rather, change only cards that are installed or preprovisioned thereafter. To change settings for installed cards or preprovisioned slots, see [Chapter 11, “Change DWDM Card Settings.”](#) To change settings for transponder or muxponder cards, see [Chapter 5, “Provision Transponder and Muxponder Cards.”](#)



**Note** Changing some NE defaults can cause CTC disconnection or a reboot of the node in order for the default to take effect. Before you change a default, view the Side Effects column of the Defaults editor (right-click a column header and select **Show Column > Side Effects**) and be prepared for the occurrence of any side effects listed for that default.

**Stop. You have completed this procedure.**

## NTP-G137 Export Network Element Defaults

|                                |                                                                                                                            |
|--------------------------------|----------------------------------------------------------------------------------------------------------------------------|
| <b>Purpose</b>                 | This procedure exports the NE defaults using the NE Defaults editor. The exported defaults can be imported to other nodes. |
| <b>Tools/Equipment</b>         | None                                                                                                                       |
| <b>Prerequisite Procedures</b> | None                                                                                                                       |
| <b>Required/As Needed</b>      | As needed                                                                                                                  |
| <b>Onsite/Remote</b>           | Onsite or remote                                                                                                           |
| <b>Security Level</b>          | Superuser                                                                                                                  |



**Note** The defaults currently displayed are exported whether or not they have been applied to the current node.



**Note** The NE defaults can also be exported from the File > Export menu. These exported defaults are for reference only and cannot be imported.



**Note** For a list of NE defaults, refer to the “Network Element Defaults” appendix in the *Cisco ONS 15454 DWDM Reference Manual*.

- Step 1** Complete the [“DLP-G46 Log into CTC” task on page 2-25](#) at the node where you want to export NE defaults.
- Step 2** In node view (single-shelf mode) or multishelf view (multishelf mode), click the **Provisioning > Defaults** editor tabs.
- Step 3** Click **Export**.

- Step 4** If the location where you want to export the file does not appear in the Export Defaults to File dialog box, click **Browse** and browse to the location.
- Step 5** Change the file name to something that is easy to remember (the file name has no extension).
- Step 6** Click **OK**.

**Stop. You have completed this procedure.**

---



## Power Down a Node

---

This chapter explains how to power down a node and stop all node activity on the Cisco ONS 15454 ANSI or ETSI.



**Note**

The CTC views referenced in this chapter depend on the ONS 15454 mode. For more information about CTC views, refer to [Appendix A, “CTC Information and Shortcuts.”](#)

---

## NTP-G119 Power Down the Node

|                                |                                         |
|--------------------------------|-----------------------------------------|
| <b>Purpose</b>                 | This procedure stops all node activity. |
| <b>Tools/Equipment</b>         | None                                    |
| <b>Prerequisite Procedures</b> | None                                    |
| <b>Required/As Needed</b>      | As needed                               |
| <b>Onsite/Remote</b>           | Onsite                                  |
| <b>Security Level</b>          | Provisioning or higher                  |



**Warning**

**Do not reach into a vacant slot or chassis while you install or remove a module or a fan. Exposed circuitry could constitute an energy hazard.** Statement 206

---



**Caution**

The following procedure is designed to minimize traffic outages when powering down nodes, but traffic will be lost if you delete and recreate circuits that passed through a working node.

---



**Note**

Always use the supplied ESD wristband when working with the Cisco ONS 15454. Plug the wristband into the ESD jack located on the fan-tray assembly or on the lower right outside edge of the shelf on the NEBS 3 shelf assembly. To access the ESD plug on the NEBS 3 shelf assembly, open the front door of the Cisco ONS 15454. The front door is grounded to prevent electrical shock.

---

- Step 1** Identify the node that you want to power down. If no cards are installed, go to [Step 16](#). If cards are installed, log into the node. See the [“DLP-G46 Log into CTC” task on page 2-25](#) for instructions.
- Step 2** Choose **Go to Network View** from the View menu.

- Step 3** Verify that the node is not connected to a network.
- If the node is part of a Software R4.7 or later dense wavelength division multiplexing (DWDM) configuration, see the “[NTP-G130 Remove a DWDM Node](#)” task on page 12-10 continue with [Step 4](#).
  - If the node is not connected to a working network and the current configurations are no longer required, proceed to [Step 4](#).



---

**Note** Before the power-down of a DWDM node, the fiber spans connected around it must be disconnected from the network. This is to prevent the accidental disconnection of wavelengths that pass through the shelf. A good indication that the shelf has been disconnected from the network is optical service channel (OSC) alarms, or no OSC channels provisioned.

---



---

**Note** Current configurations will be saved if [Steps 4](#) to [16](#) are skipped.

---

- Step 4** In node view (single-shelf mode) or multishelf view (multishelf mode), click the **Circuits** tab and verify that no circuits appear, then proceed to [Step 5](#). If circuits appear, delete all the circuits that originate or terminate in the node. Complete the “[DLP-G106 Delete Optical Channel Network Connections](#)” task on page 7-13, the “[DLP-G347 Delete Optical Channel Client Connections](#)” task on page 7-8, or the “[DLP-G112 Delete Overhead Circuits](#)” task on page 7-29 as needed.



---

**Note** When deleting circuits from a node, make sure that the node is not connected to any network.

---

- Step 5** In node view (single-shelf mode) or shelf view (multishelf mode), click the **Provisioning > Protection** tabs and delete all protection groups:

- Click the protection group that needs to be deleted and click **Delete**.
- Click **Yes**.

Repeat until no protection groups appear.

- Step 6** In node view (single-shelf mode) or multishelf view (multishelf mode), click the **Provisioning > Comm Channels** tabs and delete all communications channel terminations:

- Click the section data communications channel (SDCC), line data communications channel (LDCC), generic communications channel (GCC), or OSC termination that needs to be deleted and click **Delete**.
- Click **Yes**.

Repeat until no SDCC, LDCC, GCC, or OSC terminations are present.



---

**Note** Before deleting the OSC termination, make sure the Ring ID is deleted. Click the **Provisioning > Comm Channels > OSC** tabs. Select the Ring ID and click **Delete**.

---

- Step 7** Before deleting any installed DWDM cards, the optical patch cords have to be deleted. In node view (single-shelf mode) or multishelf view (multishelf mode), click **Provisioning > WDM-ANS > Connections** tabs.

- Select all the connections and click **Delete**.
- Click **Yes**.

- Step 8** For each installed channel-bearing card (AD-1C-xx.x, AD-2C-xx.x, and AD-4C-xx.x, where xx.x refers to the specific wavelengths), make sure all lines and bands are not in IS-NR (ANSI) or Unlocked-Enabled (ETSI) service state:
- In card view, click the **Provisioning > Optical Line > Parameters** tabs.
  - In the Admin State column for each line, make sure that the default state IS, AINS (ANSI) or Unlocked,automaticInservice (ETSI) is selected.
  - Click the **Provisioning > Optical Chn > Parameters** tabs.
  - In the Admin State column for each line, make sure that the default state IS, AINS (ANSI) or Unlocked,automaticInservice (ETSI) is selected.
- Step 9** For each installed DWDM band-bearing card (AD-1B-xx.x and AD-4B-xx.x, where xx.x refers to the specific wavelengths), make sure all lines and bands are not in the IS-NR (ANSI) or Unlocked-Enabled (ETSI) service state:
- In card view, click the **Provisioning > Optical Line > Parameters** tabs.
  - In the Admin State column for each line, make sure that the default state IS, AINS (ANSI) or Unlocked,automaticInservice (ETSI) is selected.
  - Click the **Provisioning > Optical Band > Parameters** tabs.
  - In the Admin State column for each line, make sure that the default state IS, AINS (ANSI) or Unlocked,automaticInservice (ETSI) is selected.
- Step 10** For each installed transponder (TXP), muxponder (MXP), multiplexer, demultiplexer or amplifier card (32MUX-O, 32DMX-0, 32DMX, 32WSS, 4MD-xx.x, OPT-BST, OPT-PRE, TXP\_MR\_10G, TXP\_MR\_10E, TXP\_MR\_2.5G, TXPP\_MR\_2.5G, MXP\_2.5G\_10G, MXP\_2.5G\_10E, MXP\_MR\_2.5G, MXPP\_MR\_2.5G), make sure all lines are not in the IS-NR (ANSI) or Unlocked-enabled (ETSI) service state:
- In card view, click the appropriate tab depending on the card:
    - For MXP\_2.5G\_10G, TXP\_MR\_10G, TXP\_MR\_10E cards, click the **Provisioning > Line > SONET** tabs if the card was provisioned for a SONET payload, or the **Provisioning > Line > SDH** tabs if the card was provisioned for an SDH payload.
    - For TXP\_MR\_2.5G, TXPP\_MR\_2.5G, and MXPP\_MR\_2.5G cards, click the **Provisioning > Line > OC48** tabs.
    - For MXP\_2.5G\_10E cards, click the **Provisioning > Line > Trunk** tabs.
    - For MXP\_MR\_2.5G cards, click the **Provisioning > Line > Client** tabs.
    - For 32MUX-O, 32DMX-0, 32DMX, 32WSS, OPT-BST, OPT-PRE cards, click the **Provisioning > Optical Line > Parameters** tabs.
    - For 32DMX and 32DMX-O cards, click the **Provisioning > Optical Chn > Parameters** tabs.
    - For 4MD-xx.x cards, click the **Provisioning > Optical Band > Parameters** tabs.
    - For OPT-BST and OPT-PRE cards, click the **Provisioning > Optical Ampli Line > Parameters** tabs.
  - In the Admin State column for each line, make sure that the default state IS, AINS (ANSI) or Unlocked,automaticInservice (ETSI) is selected.
  - Repeat Steps **a** and **b** for each installed DWDM card.

**Note**

---

Ports are put in service when circuits are provisioned, and put out of service when circuits are deleted. When circuits are deleted the Admin State displays as IS, AINS (ANSI) or Unlocked,automaticInService (ETSI) and the Service State displays OOS-AU,AINS (ANSI) or Unlocked-disabled,automaticInService (ETSI).

---

- Step 11** Remove all fiber connections to the cards.
- Step 12** In node view (single-shelf mode) or shelf view (multishelf mode), right-click an installed card and click **Delete**.
- Step 13** Click **Yes**.
- Step 14** After you have deleted the card, open the card ejectors and remove it from the node.
- Step 15** Repeat [Step 11](#) through [Step 14](#) for each installed card.

**Note**

---

You cannot delete a TCC2 or TCC2P card in Cisco Transport Controller (CTC). Physically remove it after all the other cards have been deleted and removed.

---

- Step 16** Shut off the power from the power supply that feeds the node.
- Step 17** Disconnect the node from its external fuse source.
- Step 18** Store all of the cards that you removed and update inventory records according to local site practice.
- Stop. You have completed this procedure.**
-



## CTC Information and Shortcuts

---



**Note**

The terms "Unidirectional Path Switched Ring" and "UPSR" may appear in Cisco literature. These terms do not refer to using Cisco ONS 15xxx products in a unidirectional path switched ring configuration. Rather, these terms, as well as "Path Protected Mesh Network" and "PPMN," refer generally to Cisco's path protection feature, which may be used in any topological network configuration. Cisco does not recommend using its path protection feature in any particular topological network configuration.

---

This appendix describes the Cisco Transport Controller (CTC) views, menus options, tool options, shortcuts, and table display options. This appendix also describes the shelf inventory data presented in CTC. For more information about CTC, refer to the "CTC Operation" chapter in the *Cisco ONS 15454 DWDM Reference Manual*.



**Note**

Unless otherwise specified, "ONS 15454" refers to both ANSI and ETSI shelf assemblies.

---



**Note**

If network discovery is enabled on the node, CTC searches each node in the network for more recent versions of the CTC software. If a more recent version is discovered, CTC gives you the option of downloading the Java archive (JAR) files to your PC.

---

### A.1 Multishelf and Single-Shelf Modes

In a DWDM configuration, CTC views can be displayed in one of two modes. If a node contains only one shelf, the possible views are network view, node view, and card view. This is known as single-shelf mode. In multishelf mode, a control node and subtending shelves are configured to operate as a single node. In this mode, four views are possible: network view, multishelf view, shelf view, and card view. Multishelf view is the home view for nodes that are configured in multishelf mode. Multishelf view displays all of the shelves in the node. When you open a shelf from multishelf view, shelf view appears, which looks similar to node view but does not contain the tabs and subtabs that are used for node-level operations.

### A.2 Display CTC Views

CTC provides four views of the ONS 15454 and the ONS network:

- If the login ONS 15454 node is in multishelf mode, the multishelf view appears when you first log into the node. This view shows a graphic of the ONS 15454 racks and provides access to tabs and subtabs that you use to manage the multishelf node and its subtending shelves.
- If the login ONS 15454 node is in single-shelf mode, node view appears when you first log into an ONS 15454. This view shows a graphic of the ONS 15454 shelf and provides access to tabs and subtabs that you use to manage the node. When you open a shelf from multishelf view, shelf view appears, which looks similar to node view but does not contain the tabs and subtabs that are used for node operations.
- Card view provides access to individual ONS 15454 cards. This view provides a graphic of the card and provides access to tabs and subtabs that you use to manage the card.
- Network view shows all the nodes in a ring and provides access to tabs and subtabs that you use to manage the network. A Superuser can create a network view that is identical for all users who log into the network or users can create custom views with maps.

Users can group a subset of nodes into a domain, which is used to isolate nodes or groups of nodes for easier maintenance and a more streamlined network view. Double-clicking a domain displays all the nodes that are members of the domain. Nodes connected to the domain nodes are grayed out.

Table A-1 lists different actions for changing CTC views.

**Table A-1**      **Change CTC Views**

| <b>To Display</b>                                                      | <b>Perform One of the Following</b>                                                                                                                                                                                                                                                                                                                                                                                                                                                                                                                                                                                                                                                                                                                                                                                                                                                                                                                                |
|------------------------------------------------------------------------|--------------------------------------------------------------------------------------------------------------------------------------------------------------------------------------------------------------------------------------------------------------------------------------------------------------------------------------------------------------------------------------------------------------------------------------------------------------------------------------------------------------------------------------------------------------------------------------------------------------------------------------------------------------------------------------------------------------------------------------------------------------------------------------------------------------------------------------------------------------------------------------------------------------------------------------------------------------------|
| Multishelf view<br>(multishelf mode)                                   | <ul style="list-style-type: none"> <li>• In network view, double-click a node icon, or right-click the node and choose <b>Open Node</b> from the shortcut menu.</li> <li>• In network view, single-click a node icon, then choose <b>Go To Selected Object View</b> from the View menu.</li> <li>• From the View menu, choose <b>Go To Other Node</b>, then choose the node you want from the shortcut menu.</li> <li>• Use the arrows on the CTC toolbar to navigate up or down views until you reach node view.</li> </ul>                                                                                                                                                                                                                                                                                                                                                                                                                                       |
| Node view<br>(single-shelf mode) or<br>shelf view (multishelf<br>mode) | <ul style="list-style-type: none"> <li>• In network view, double-click a node icon, or right-click the node and choose <b>Open Node</b> from the shortcut menu. If the node is in multishelf view (multishelf mode), double-click a shelf icon, or right-click and choose <b>Open Shelf</b> from the shortcut menu.</li> <li>• In network view, single-click a node icon, then choose <b>Go To Selected Object View</b> from the View menu. If the node is in multishelf mode, double-click a shelf icon, or right-click and choose <b>Open Shelf</b> from the shortcut menu.</li> <li>• In multishelf view (multishelf mode), double-click a shelf icon, or right-click and choose <b>Open Shelf</b> from the shortcut menu.</li> <li>• From the View menu, choose <b>Go To Other Node</b>, then choose the node you want from the shortcut menu.</li> <li>• Use the arrows on the CTC toolbar to navigate up or down views until you reach node view.</li> </ul> |



**Table A-1** *Change CTC Views (continued)*

| <b>To Display</b> | <b>Perform One of the Following</b>                                                                                                                                                                                                                                                                                                                                                                                                                                |
|-------------------|--------------------------------------------------------------------------------------------------------------------------------------------------------------------------------------------------------------------------------------------------------------------------------------------------------------------------------------------------------------------------------------------------------------------------------------------------------------------|
| Network view      | <ul style="list-style-type: none"> <li>• In node view (single-shelf mode) or multishelf view (multishelf mode), click the up arrow or the Network View tool on the CTC toolbar. If in shelf view (multishelf mode), you must click the up arrow twice.</li> <li>• In multishelf view (multishelf mode), click the up arrow or the Network View tool on the CTC toolbar.</li> <li>• From the View menu, choose <b>Go To Network View</b>.</li> </ul>                |
| Card view         | <ul style="list-style-type: none"> <li>• In node view, double-click a card or right-click the card and choose <b>Open Card</b>.</li> <li>• In node view (single-shelf mode) or shelf view (multishelf mode), single-click a card icon, then choose <b>Go To Selected Object View</b> from the View menu.</li> <li>• Use the arrows on the CTC toolbar to navigate up or down views. For example, in node view, click a card, then click the down arrow.</li> </ul> |

## A.2.1 Node Icons on the Network View Map

[Table A-2](#) lists the node icons on the network view map.

Table A-2 Description of Node Icons on Network View Map









| Node Name                                                                                                           | Icon                                                                                | Description                                                                                                                                                                                                                                                                                                                                                                                                                                                                                                                                                                                                                                                                                                                                                                                                                                                                                                                                                                                                                                                                                                                                                                          |
|---------------------------------------------------------------------------------------------------------------------|-------------------------------------------------------------------------------------|--------------------------------------------------------------------------------------------------------------------------------------------------------------------------------------------------------------------------------------------------------------------------------------------------------------------------------------------------------------------------------------------------------------------------------------------------------------------------------------------------------------------------------------------------------------------------------------------------------------------------------------------------------------------------------------------------------------------------------------------------------------------------------------------------------------------------------------------------------------------------------------------------------------------------------------------------------------------------------------------------------------------------------------------------------------------------------------------------------------------------------------------------------------------------------------|
| SONET<br>SDH<br>Hybrid OADM<br>Hybrid line amplifier<br>Hybrid terminal<br>Passive hybrid terminal<br>Amplified TDM |    | <p>A SONET, SDH, hybrid, or amplified time-division multiplexing (TDM) node icon is represented as a cylinder with crossed arrows.</p> <ul style="list-style-type: none"> <li>• A SONET or SDH node can include OC-N cards, electrical cards, cross-connects, Storage Access Management (SAM) cards, and Ethernet cards.</li> <li>• A hybrid optical add/drop multiplexing (OADM) node contains at least one AD-xC-xx.x card or one AD-xB-xx.x card and two TCC2/TCC2P cards. TDM cards can be installed in any available slot.</li> <li>• A hybrid line amplifier node contains amplifiers and both TDM and dense wavelength division multiplexing (DWDM) cards.</li> <li>• A hybrid terminal node contains at least one 32MUX-O card, one 32DMX-O card, amplifiers, two TCC2/TCC2P cards, and TDM cards.</li> <li>• A passive hybrid terminal node has the same equipment as the hybrid terminal node, but does not contain amplifiers.</li> <li>• An amplified TDM node is a node that increases the span length between two ONS 15454 nodes that contain TDM cards and optical amplifiers. Amplified TDM nodes contain either OPT-BST amplifiers or AD-1C-xx.x cards.</li> </ul> |
| Hub                                                                                                                 |  | <p>A DWDM hub node icon is represented as a three-dimensional cylinder with amplifiers. A hub node contains at least two 32DMX or 32DMX-O cards and two 32MUX-O cards. No OADM cards are provisioned.</p>                                                                                                                                                                                                                                                                                                                                                                                                                                                                                                                                                                                                                                                                                                                                                                                                                                                                                                                                                                            |
| OADM                                                                                                                |  | <p>A DWDM OADM node icon is represented as a three-dimensional cylinder with arrows. An OADM node contains at least one AD-xC-xx.x card or one AD-xB-xx.x card. No 32MUX-O, 32DMX-O, or 32DMX cards are provisioned.</p>                                                                                                                                                                                                                                                                                                                                                                                                                                                                                                                                                                                                                                                                                                                                                                                                                                                                                                                                                             |
| ROADM                                                                                                               |  | <p>A reconfigurable OADM (ROADM) node icon is represented as a three-dimensional cylinder with two amplifier symbols that have arrows between them. An ROADM node contains at least one 32WSS card. A single-slot 32DMX or double-slot 32DMX-O can be installed, but is not required. Transponders (TXPs) and muxponders (MXPs) can be installed in Slots 6 and 12. If amplification is not used, TXPs or MXPs can be installed in Slots 1 and 17. If OPT-BSTs are not installed, OSC-CSM cards are installed in Slots 2 and 16 and Slots 8 and 10 are empty.</p>                                                                                                                                                                                                                                                                                                                                                                                                                                                                                                                                                                                                                    |

Table A-2 Description of Node Icons on Network View Map (continued)

| Node Name                     | Icon                                                                                | Description                                                                                                                                                                                                                                                                                                                                                                    |
|-------------------------------|-------------------------------------------------------------------------------------|--------------------------------------------------------------------------------------------------------------------------------------------------------------------------------------------------------------------------------------------------------------------------------------------------------------------------------------------------------------------------------|
| Terminal (west)               |    | <p>A terminal (west) node is represented as a three-dimensional cylinder with one amplifier on the right side of the icon.</p> <ul style="list-style-type: none"> <li>• A terminal node contains one 32DMX or 32DMX-O card and one 32-MUX-O card. No OADM cards are provisioned.</li> <li>• A flexible terminal node contains a series of OADM and amplifier cards.</li> </ul> |
| Terminal (east)               |    | <p>A terminal (east) node is represented as a three-dimensional square with one amplifier on the left side of the icon.</p> <ul style="list-style-type: none"> <li>• A terminal node contains one 32DMX or 32DMX-O card and one 32MUX-O card. No OADM cards are provisioned.</li> <li>• A flexible terminal node contains a series of OADM and amplifier cards.</li> </ul>     |
| Line<br>OSC regeneration line |    | <p>Line and OSC regeneration line nodes are represented as a three-dimensional cylinder with one arrow pointing west and another arrow pointing east.</p> <ul style="list-style-type: none"> <li>• A line node has only OPT-PRE or OPT-BST amplifiers provisioned.</li> <li>• An optical service channel (OSC) regeneration line node contains two OSC-CSM cards.</li> </ul>   |
| Unknown                       |  | <p>An unknown DWDM node icon is represented as a three-dimensional cylinder with one arrow pointing north. An unknown node means that the provisioned cards do not allow the node to fit any of the defined DWDM node categories.</p>                                                                                                                                          |

## A.3 Manage the CTC Window

Different navigational methods are available within the CTC window to access views and perform management actions. You can double-click and right-click objects in the graphic area and move the mouse over nodes, cards, and ports to view popup status information.

### A.3.1 CTC Menu and Toolbar Options

The CTC window menu bar and toolbar provide primary CTC functions. [Table A-3](#) shows the actions that are available from the CTC menu and toolbar.

Table A-3 CTC Menu and Toolbar Options







| Menu | Menu Option          | Toolbar                                                                             | Description                                                                                                                                                                                                                                                                                                                                                                                                                                                                                                                                                                                                                                                                                                                                                                                                                                                                                                                                                                                                                                                                                                                           |
|------|----------------------|-------------------------------------------------------------------------------------|---------------------------------------------------------------------------------------------------------------------------------------------------------------------------------------------------------------------------------------------------------------------------------------------------------------------------------------------------------------------------------------------------------------------------------------------------------------------------------------------------------------------------------------------------------------------------------------------------------------------------------------------------------------------------------------------------------------------------------------------------------------------------------------------------------------------------------------------------------------------------------------------------------------------------------------------------------------------------------------------------------------------------------------------------------------------------------------------------------------------------------------|
| File | Add Node             |    | Adds a node to the current session. See the <a href="#">“DLP-G49 Add a Node to the Current Session or Login Group”</a> task on page 2-30.                                                                                                                                                                                                                                                                                                                                                                                                                                                                                                                                                                                                                                                                                                                                                                                                                                                                                                                                                                                             |
|      | Delete Selected Node |    | Deletes a node from the current session.                                                                                                                                                                                                                                                                                                                                                                                                                                                                                                                                                                                                                                                                                                                                                                                                                                                                                                                                                                                                                                                                                              |
|      | Lock CTC             |    | Locks CTC without closing the CTC session. A user name and password are required to open CTC.                                                                                                                                                                                                                                                                                                                                                                                                                                                                                                                                                                                                                                                                                                                                                                                                                                                                                                                                                                                                                                         |
|      | Print                |    | Prints CTC data. See the <a href="#">“DLP-G113 Print CTC Data”</a> task on page 8-2.                                                                                                                                                                                                                                                                                                                                                                                                                                                                                                                                                                                                                                                                                                                                                                                                                                                                                                                                                                                                                                                  |
|      | Export               |    | Exports CTC data. See the <a href="#">“DLP-G114 Export CTC Data”</a> task on page 8-4.                                                                                                                                                                                                                                                                                                                                                                                                                                                                                                                                                                                                                                                                                                                                                                                                                                                                                                                                                                                                                                                |
|      | Exit                 | —                                                                                   | Closes the CTC session.                                                                                                                                                                                                                                                                                                                                                                                                                                                                                                                                                                                                                                                                                                                                                                                                                                                                                                                                                                                                                                                                                                               |
| Edit | Preferences          |  | <p>Displays the Preferences dialog box, which shows the following tabs:</p> <ul style="list-style-type: none"> <li>• General—Allows you to change event defaults and manage preferences.</li> <li>• Login Node Groups—Allows you to create login node groups. See the <a href="#">“DLP-G48 Create Login Node Groups”</a> task on page 2-29.</li> <li>• Map—Allows you to customize the network view. See the <a href="#">“DLP-G168 Change the Network View Background Color”</a> task on page 10-26 and the <a href="#">“DLP-G170 Apply a Custom Network View Background Map”</a> task on page 10-28.</li> <li>• Circuit—Allows you to change the color of circuit spans. This task is not applicable on DWDM-only nodes.</li> <li>• Firewall—Sets the Internet Inter-ORB Protocol (IIOP) listener ports for access to the ONS 15454 through a firewall. See the <a href="#">“NTP-G27 Set Up the ONS 15454 for Firewall Access”</a> procedure on page 3-24.</li> <li>• JRE—Allows you to select another Java Runtime Environment (JRE) version. See the <a href="#">“DLP-G52 Change the JRE Version”</a> task on page 2-8.</li> </ul> |

Table A-3 CTC Menu and Toolbar Options (continued)











| Menu | Menu Option                | Toolbar                                                                             | Description                                                                                                                                                                                                                                                                                                                                                                                                                                                                             |
|------|----------------------------|-------------------------------------------------------------------------------------|-----------------------------------------------------------------------------------------------------------------------------------------------------------------------------------------------------------------------------------------------------------------------------------------------------------------------------------------------------------------------------------------------------------------------------------------------------------------------------------------|
| View | Go To Previous View        |    | Displays the previous CTC view. Available only after you navigate to a next view.                                                                                                                                                                                                                                                                                                                                                                                                       |
|      | Go To Next View            |    | Displays the next CTC view. Go to Previous View and Go to Next View are similar to forward and backward navigation in a web browser.                                                                                                                                                                                                                                                                                                                                                    |
|      | Go To Parent View          |    | References the CTC view hierarchy: network view, multishelf view (multishelf mode), node view (single-shelf mode), shelf view (multishelf mode), and card view. In card view, this command displays the node view (single-shelf mode) or shelf view (multishelf mode); in node view (single-shelf mode) or multishelf view (multishelf mode), the command displays network view. Not available in network view. In shelf view (multishelf mode), this command displays multishelf view. |
|      | Go To Selected Object View |    | Displays the object selected in the CTC window.                                                                                                                                                                                                                                                                                                                                                                                                                                         |
|      | Go To Home View            |   | Displays the login node in node view (single-shelf mode) or multishelf view (multishelf mode). If the login node is a multishelf node controller, the multishelf view displays.                                                                                                                                                                                                                                                                                                         |
|      | Go To Network View         |  | Displays the network view.                                                                                                                                                                                                                                                                                                                                                                                                                                                              |
|      | Go To Other Node           |  | Displays a dialog box allowing you to type in the node name or IP address of a network node that you want to view.                                                                                                                                                                                                                                                                                                                                                                      |
|      | Show Status Bar            | —                                                                                   | Click this item to display or hide the status bar at the bottom of the CTC window.                                                                                                                                                                                                                                                                                                                                                                                                      |
|      | Show Tool Bar              | —                                                                                   | Click this item to display or hide the CTC toolbar.                                                                                                                                                                                                                                                                                                                                                                                                                                     |
| —    | —                          |  | (Toolbar only) Zooms out the network view area.                                                                                                                                                                                                                                                                                                                                                                                                                                         |
| —    | —                          |  | (Toolbar only) Zooms in the network view area.                                                                                                                                                                                                                                                                                                                                                                                                                                          |
| —    | —                          |  | (Toolbar only) Zooms in a selected network view area.                                                                                                                                                                                                                                                                                                                                                                                                                                   |

Table A-3 CTC Menu and Toolbar Options (continued)





| Menu       | Menu Option         | Toolbar                                                                                             | Description                                                                                                                                                                                                                                                                                                                                                                                                                                                                                                                                                                                                                                                                                                                                                                                                                                                       |
|------------|---------------------|-----------------------------------------------------------------------------------------------------|-------------------------------------------------------------------------------------------------------------------------------------------------------------------------------------------------------------------------------------------------------------------------------------------------------------------------------------------------------------------------------------------------------------------------------------------------------------------------------------------------------------------------------------------------------------------------------------------------------------------------------------------------------------------------------------------------------------------------------------------------------------------------------------------------------------------------------------------------------------------|
| Tools      | Circuits            | —                                                                                                   | Displays the following options: <ul style="list-style-type: none"> <li>Repair Circuits—Repairs incomplete circuits following replacement of the ONS 15454 alarm interface panel (AIP). Refer to the <i>Cisco ONS 15454 DWDM Troubleshooting Guide</i> for more information.</li> <li>Reconfigure Circuits—Allows you to reconfigure circuits. Not applicable to DWDM nodes.</li> <li>Set Path Selector Attributes—Allows you to edit path protection or subnetwork connection protection (SNCP) circuit path selector attributes. Not applicable on DWDM nodes.</li> <li>Set Circuit State—Allows you to change a circuit state. Not applicable on DWDM nodes.</li> <li>Roll Circuit—Allows you to reroute live traffic without interrupting service.</li> <li>Delete Rolls—Removes rolls that are not deleted by CTC after a roll has been completed.</li> </ul> |
|            | Overhead Circuits   | —                                                                                                   | (SONET and SDH only) Displays the Repair IP Tunnels option, which fixes circuits that are in the PARTIAL status as a result of node IP address changes.                                                                                                                                                                                                                                                                                                                                                                                                                                                                                                                                                                                                                                                                                                           |
|            | Topology Upgrade    | —                                                                                                   | Displays the following options: <ul style="list-style-type: none"> <li>Convert UPSR to BLSR (or Convert SNCP to MS-SPRing)—Converts a path protection to a bidirectional line switch ring (BLSR) or an SNCP to a multiplex section-shared protection ring (MS-SPRing). Not applicable to DWDM nodes.</li> <li>Convert Unprotected to UPSR (or SNCP)—Converts a point-to-point or linear add/drop multiplexer (ADM) to path protection or SNCP. Not applicable to DWDM nodes.</li> </ul>                                                                                                                                                                                                                                                                                                                                                                           |
|            | Manage VLANs        | —                                                                                                   | Displays a list of VLANs that have been created and allows you to delete VLANs. Not applicable to DWDM nodes.                                                                                                                                                                                                                                                                                                                                                                                                                                                                                                                                                                                                                                                                                                                                                     |
|            | Manage TL1 Tunnels  | —                                                                                                   | Displays existing TL1 tunnels; allows you to create, edit, and delete the tunnels.                                                                                                                                                                                                                                                                                                                                                                                                                                                                                                                                                                                                                                                                                                                                                                                |
|            | Open TL1 Connection |                  | Displays the TL1 session dialog box so you can create a TL1 session to a specific node. Refer to the <i>Cisco ONS SONET TL1 Reference Guide</i> and the <i>Cisco ONS 15454 SDH TL1 Reference Guide</i> .                                                                                                                                                                                                                                                                                                                                                                                                                                                                                                                                                                                                                                                          |
|            | Open IOS Connection |                  | Displays the Cisco IOS command line interface (CLI) dialog box if a Cisco IOS capable card (ML1000-2, ML100T-12, or ML-100X-8) is installed in the node. Not applicable to DWDM nodes.                                                                                                                                                                                                                                                                                                                                                                                                                                                                                                                                                                                                                                                                            |
| Update CTC | —                   | Allows you to update CTC to a newer version, if a newer version was found during network discovery. |                                                                                                                                                                                                                                                                                                                                                                                                                                                                                                                                                                                                                                                                                                                                                                                                                                                                   |
| Help       | Contents and Index  | —                                                                                                   | Displays the online help window.                                                                                                                                                                                                                                                                                                                                                                                                                                                                                                                                                                                                                                                                                                                                                                                                                                  |
|            | User Manuals        | —                                                                                                   | Displays the Cisco ONS 15454 documentation.                                                                                                                                                                                                                                                                                                                                                                                                                                                                                                                                                                                                                                                                                                                                                                                                                       |
|            | About CTC           | —                                                                                                   | Displays the software version and the nodes in the CTC session.                                                                                                                                                                                                                                                                                                                                                                                                                                                                                                                                                                                                                                                                                                                                                                                                   |

Table A-3 CTC Menu and Toolbar Options (continued)

| Menu | Menu Option   | Toolbar                                                                                                                                                                | Description                                                                                                                                                                                                                                                                                                                                                                                                                                                                                                                                                                                                                                                                                                                                                                                                                                                                                                                                                                                                                                                                                                                                                                                                                                                                                                                                  |
|------|---------------|------------------------------------------------------------------------------------------------------------------------------------------------------------------------|----------------------------------------------------------------------------------------------------------------------------------------------------------------------------------------------------------------------------------------------------------------------------------------------------------------------------------------------------------------------------------------------------------------------------------------------------------------------------------------------------------------------------------------------------------------------------------------------------------------------------------------------------------------------------------------------------------------------------------------------------------------------------------------------------------------------------------------------------------------------------------------------------------------------------------------------------------------------------------------------------------------------------------------------------------------------------------------------------------------------------------------------------------------------------------------------------------------------------------------------------------------------------------------------------------------------------------------------|
| —    | Network Scope | —                                                                                                                                                                      | Displays the selected network scope. The network scope drop-down list has three options: DWDM, TDM, or All. If you choose DWDM, DWDM and hybrid nodes appear on the network view map. If you choose TDM, TDM and hybrid nodes appear on the network view map. If you choose All, every node on the network appears on the network view map.                                                                                                                                                                                                                                                                                                                                                                                                                                                                                                                                                                                                                                                                                                                                                                                                                                                                                                                                                                                                  |
| —    | Link Filter   |                                                                                       | <p>Opens the Link Filter dialog box, which allows you to choose which link classes appear on the nondetail network map. The available classes vary according to the selected network scope.</p> <ul style="list-style-type: none"> <li>• ALL—DCC, GCC, OTS, PPC</li> <li>• DWDM—GCC, OTS, PPC</li> <li>• TDM—DCC, PPC</li> </ul>                                                                                                                                                                                                                                                                                                                                                                                                                                                                                                                                                                                                                                                                                                                                                                                                                                                                                                                                                                                                             |
| —    | —             | <br> | <p>Opens the CTC Alerts dialog box, which shows the status of certain CTC background tasks. When the CTC Alerts toolbar icon contains a red triangle, unread notifications exist. When there are no unread notifications, the CTC Alerts toolbar icon contains a gray triangle (see the icons in the Toolbar column for comparison). Notifications include:</p> <ul style="list-style-type: none"> <li>• Network disconnection.</li> <li>• Send-PDIP inconsistency—CTC discovers a new node that does not have a SEND-PDIP setting consistent with the login node.</li> <li>• Circuit deletion status—Reports when the circuit deletion process completes if you chose “Notify when complete” as described in the <a href="#">“NTP-G60 Create and Delete Overhead Circuits” procedure on page 7-21</a>. The CTC Alerts window always reports circuit deletion errors.</li> <li>• Conditions retrieval error.</li> <li>• Software download failure.</li> </ul> <p>You can save a notification by clicking the Save button in the CTC Alerts dialog box and navigating to the directory where you want to save the text file.</p> <p>By default, the CTC Alerts dialog box appears automatically. To disable automatic popup, see the <a href="#">“DLP-G53 Configure the CTC Alerts Dialog Box for Automatic Popup” task on page 2-32</a>.</p> |

## A.3.2 CTC Mouse Options

In addition to the CTC menu bar and toolbar, you can invoke actions by double-clicking CTC window items with your mouse, or by right-clicking an item and selecting actions from shortcut menus.

[Table A-4](#) lists the CTC window mouse shortcuts.

**Table A-4** CTC Window Mouse Shortcuts

| Technique    | Description                                                                                                                                                                                                                                                                                                                                                                                                                                                                                                                                                                                                                                                                                                                                                                                                                                                                                                                                                                                                                                                                                                                                                                                                                                                                                                                                                                                                                                                                                                                                                                                                                                                                                                                                                                                                                                                                                                                                                                                                                                                                                                                                                                                    |
|--------------|------------------------------------------------------------------------------------------------------------------------------------------------------------------------------------------------------------------------------------------------------------------------------------------------------------------------------------------------------------------------------------------------------------------------------------------------------------------------------------------------------------------------------------------------------------------------------------------------------------------------------------------------------------------------------------------------------------------------------------------------------------------------------------------------------------------------------------------------------------------------------------------------------------------------------------------------------------------------------------------------------------------------------------------------------------------------------------------------------------------------------------------------------------------------------------------------------------------------------------------------------------------------------------------------------------------------------------------------------------------------------------------------------------------------------------------------------------------------------------------------------------------------------------------------------------------------------------------------------------------------------------------------------------------------------------------------------------------------------------------------------------------------------------------------------------------------------------------------------------------------------------------------------------------------------------------------------------------------------------------------------------------------------------------------------------------------------------------------------------------------------------------------------------------------------------------------|
| Double-click | <ul style="list-style-type: none"> <li>• Node in network view—Displays the node view (single-shelf mode) or multishelf view (multishelf mode) view.</li> <li>• Domain in network view—Displays the domain view.</li> <li>• Shelf in multishelf view—Displays the shelf view.</li> <li>• Card in node view (single-shelf mode) or shelf view (multishelf mode)—Displays the card view.</li> <li>• Alarm/Event—Displays the object that raised the alarm or event.</li> <li>• Circuits—Displays the Edit Circuit window.</li> </ul>                                                                                                                                                                                                                                                                                                                                                                                                                                                                                                                                                                                                                                                                                                                                                                                                                                                                                                                                                                                                                                                                                                                                                                                                                                                                                                                                                                                                                                                                                                                                                                                                                                                              |
| Right-click  | <ul style="list-style-type: none"> <li>• Network view graphic area—Displays a shortcut menu that you can use to create a new domain; change the position and zoom level of the graphic image; save the map layout (if you have a Superuser security level); reset the default layout of the network view; set, change, or remove the background image and color; and save or reset the node position.</li> <li>• Domain in network view—Displays a shortcut menu that you can use to open a domain, show the domain overview, rename the domain, and delete the domain.</li> <li>• Node in network view—Displays a shortcut menu that you can use to open the node, reset the node icon position to the longitude and latitude that is set on the Provisioning &gt; General tab, delete the node, fix the node position for automatic layout, provision circuits, provision channels, and update circuits or channels with a new node.</li> <li>• Multishelf view (multishelf mode)—Right-clicking over an existing shelf displays a shortcut menu that you can use to open or delete a shelf. Right-clicking over an empty space in a rack displays a shortcut menu that allows you to add a shelf. Right-clicking over an empty space that is outside of a rack displays a shortcut menu that you can use to add a new rack. Right-clicking over the rack number displays a shortcut menu that you can use to delete a rack.</li> <li>• Span in network view—Displays a shortcut menu that you can use to view information about the span's source and destination ports, the protection scheme, and the optical or electrical level.</li> <li>• Card in node view (single-shelf mode) or shelf view (multishelf mode)—Displays a shortcut menu that you can use to open, delete, reset, and change cards. The card that you choose determines the commands that appear.</li> <li>• Card in card view—Displays a shortcut menu that you can use to reset the card, or go to the parent view (node view).</li> <li>• Empty slot in node view (single-shelf mode) or shelf view (multishelf mode)—Displays a shortcut menu with cards that you can choose to preprovision the slot.</li> </ul> |



**Table A-4** *CTC Window Mouse Shortcuts (continued)*

| Technique         | Description                                                                                                                                                                                                                                                                                                                                                                                                                                                                                                                                                                                                                                                                                                                                                                                                                                                                                                                                                                                                                                                                                                                                                                    |
|-------------------|--------------------------------------------------------------------------------------------------------------------------------------------------------------------------------------------------------------------------------------------------------------------------------------------------------------------------------------------------------------------------------------------------------------------------------------------------------------------------------------------------------------------------------------------------------------------------------------------------------------------------------------------------------------------------------------------------------------------------------------------------------------------------------------------------------------------------------------------------------------------------------------------------------------------------------------------------------------------------------------------------------------------------------------------------------------------------------------------------------------------------------------------------------------------------------|
| Move mouse cursor | <ul style="list-style-type: none"> <li>Over node in network view—Displays a summary of node alarms and provides a warning if the node icon has been moved out of the map range.</li> <li>Over span in network view—Displays circuit (node, slot, port) bandwidth and protection information. For DWDM spans, the optical direction and optical ring ID appear. If the span terminates on the trunk port of a transponder (TXP) or muxponder (MXP) card, the associated DWDM wavelength also appears.</li> <li>Over domain in network view—Displays domain name and the number of nodes in the domain.</li> <li>Over card in node view (single-shelf mode) or multishelf view (multishelf mode)—Displays card type, card status, alarm profile status and, depending on the DWDM card type, number of bands or channels.</li> <li>Over card port in node/shelf view—Displays card name, port state, and alarm profile status.</li> <li>Over card port in card view—Displays port state and alarm profile status. For DWDM cards, the port number is labeled as channel, band, or line depending on the card type along with the port state and alarm profile status.</li> </ul> |

### A.3.3 Multishelf View Shortcuts

Table A-5 shows actions on ONS 15454 cards that you can perform by moving your mouse over the CTC window in multishelf view (multishelf mode).

**Table A-5** *Multishelf View Card-Related Shortcuts*

| Action                   | Shortcut                                                                                                                                                                                                                               |
|--------------------------|----------------------------------------------------------------------------------------------------------------------------------------------------------------------------------------------------------------------------------------|
| Display card information | In multishelf view (multishelf mode), move your mouse over cards in the graphic to display tool tips with the card type, card status (active or standby), the highest level of alarm (if any), and the alarm profile used by the card. |

### A.3.4 Node View (Single-Shelf Mode) and Shelf View (Multishelf Mode) Shortcuts

Table A-6 shows actions that you can perform by moving your mouse in the CTC window in node (single-shelf mode) or shelf (multishelf mode) view.

**Table A-6 Node/Shelf View Card-Related Shortcuts**

| Action                        | Shortcut                                                                                                                                                                                                                                                                                                                             |
|-------------------------------|--------------------------------------------------------------------------------------------------------------------------------------------------------------------------------------------------------------------------------------------------------------------------------------------------------------------------------------|
| Display card information      | In node view (single-shelf mode) or shelf view (multishelf mode), move your mouse over cards in the graphic to display tool tips with the card type, card status (active or standby), the highest level of alarm (if any), and the alarm profile used by the card.                                                                   |
| Open, reset, or delete a card | In node view (single-shelf mode) or shelf view (multishelf mode), right-click a card. Choose <b>Open Card</b> to display the card in card view, <b>Delete Card</b> to delete it, or <b>Reset Card</b> to reset the card.                                                                                                             |
| Provision a slot              | In node view (single-shelf mode) or shelf view (multishelf mode), right-click an empty slot. Choose the card type for which you want to provision the slot from the shortcut menu.                                                                                                                                                   |
| Change a card                 | In node view (single-shelf mode) or shelf view (multishelf mode), right-click an OC-N card or a DS3 card, and choose <b>Change Card</b> . In the Change Card dialog box, choose the card type. Change Card retains all card provisioning, including data communications channel (DCC) terminations, protection, circuits, and rings. |

## A.3.5 Network View Tasks

Right-click the network view graphic area or a node, span, or domain to display shortcut menus.

[Table A-7](#) lists the actions that are available from the network view.

**Table A-7 Network Management Tasks in Network View**

| Action                   | Task                                                                                                                                                                                                                                                                                                                                                                                                                                                                          |
|--------------------------|-------------------------------------------------------------------------------------------------------------------------------------------------------------------------------------------------------------------------------------------------------------------------------------------------------------------------------------------------------------------------------------------------------------------------------------------------------------------------------|
| Open a node              | Any of the following: <ul style="list-style-type: none"> <li>• Double-click a node icon.</li> <li>• Right-click a node icon and choose <b>Open Node</b> from the shortcut menu.</li> <li>• Click a node and choose <b>Go To Selected Object View</b> from the View menu.</li> <li>• From the View menu, choose <b>Go To Other Node</b>. Choose a node from the Select Node dialog box.</li> <li>• Double-click a node alarm or event in the Alarms or History tab.</li> </ul> |
| Move a node icon         | Press the <b>Ctrl</b> key and the left mouse button simultaneously and drag the node icon to a new location.                                                                                                                                                                                                                                                                                                                                                                  |
| Reset node icon position | Right-click a node and choose <b>Reset Node Position</b> from the shortcut menu. The node icon moves to the position defined by the longitude and latitude fields on the Provisioning > General tab in node view (single-shelf mode) or multishelf view (multishelf mode).                                                                                                                                                                                                    |
| Consolidate links        | Right-click on a link and choose <b>Consolidate/Expand</b> from the shortcut menu. For more detailed instructions, refer to <a href="#">Chapter 10, "Manage the Node."</a>                                                                                                                                                                                                                                                                                                    |
| Provision a circuit      | Right-click a node. From the shortcut menu, choose <b>Provision Circuit To</b> and choose the node where you want to provision the circuit. For circuit creation procedures, see <a href="#">Chapter 7, "Create Channels and Circuits."</a>                                                                                                                                                                                                                                   |

**Table A-7** Network Management Tasks in Network View (continued)

| Action                                                                    | Task                                                                                                                                                                                                                                                                                                                       |
|---------------------------------------------------------------------------|----------------------------------------------------------------------------------------------------------------------------------------------------------------------------------------------------------------------------------------------------------------------------------------------------------------------------|
| Update circuits with new node                                             | Right-click a node and choose <b>Update Circuits With New Node</b> from the shortcut menu. Use this command when you add a new node and want to pass circuits through it.                                                                                                                                                  |
| Display a link end point                                                  | Right-click a span. From the shortcut menu, choose <b>Go To</b> {<node>   <port>   <slot>} for the drop port you want to view. CTC displays the card in card view.                                                                                                                                                         |
| Display span properties                                                   | Do any of the following: <ul style="list-style-type: none"> <li>• Move the mouse over a span; the properties appear near the span.</li> <li>• Click a span; the properties appear in the upper left corner of the window.</li> <li>• Right-click a span; the properties appear at the top of the shortcut menu.</li> </ul> |
| Perform a UPSR (ANSI) or SNCP (ETSI) protection switch for an entire span | Right-click a network span and click <b>Circuits</b> . In the Circuits on Span dialog box, switch options appear in the UPSR (or SNCP) Span Switching field.                                                                                                                                                               |
| Display DWDM span properties                                              | Right-click a DWDM network span and choose <b>Circuits</b> from the shortcut menu. The optical channel network connection (OCHNC), optical direction, and circuit appear.                                                                                                                                                  |
| Upgrade a span                                                            | Right-click a span and choose <b>Upgrade Span</b> from the shortcut menu. Not applicable to DWDM nodes.                                                                                                                                                                                                                    |

## A.3.6 Table Display Options

Right-clicking a table column displays a shortcut menu. [Table A-8](#) shows table display options, which include rearranging or hiding CTC table columns and sorting table columns by primary or secondary keys.

**Table A-8** Table Display Options

| Task                       | Click                                                                           | Right-Click Shortcut Menu                        |
|----------------------------|---------------------------------------------------------------------------------|--------------------------------------------------|
| Resize column              | Click while dragging the column separator to the right or left.                 | —                                                |
| Rearrange column order     | Click while dragging the column header to the right or left.                    | —                                                |
| Reset column order         | —                                                                               | Choose <b>Reset Columns Order/Visibility</b> .   |
| Hide column                | —                                                                               | Choose <b>Hide Column</b> .                      |
| Show column                | —                                                                               | Choose <b>Show Column</b> > <i>column_name</i> . |
| Display all hidden columns | —                                                                               | Choose <b>Reset Columns Order/Visibility</b> .   |
| Sort table (primary)       | Click a column header; each click changes sort order (ascending or descending). | Choose <b>Sort Column</b> .                      |

Table A-8 Table Display Options (continued)

| Task                                | Click                                                                  | Right-Click Shortcut Menu                                                      |
|-------------------------------------|------------------------------------------------------------------------|--------------------------------------------------------------------------------|
| Sort table (secondary sorting keys) | Press the <b>Shift</b> key and simultaneously click the column header. | Choose <b>Sort Column (incremental)</b> .                                      |
| Reset sorting                       | —                                                                      | Choose <b>Reset Sorting</b> .                                                  |
| View table row count                | —                                                                      | View the number after “Row count=” (it is the last item on the shortcut menu). |

## A.4 Equipment Inventory

In node view (single-shelf mode) and multishelf view (multishelf mode), the Inventory tab displays information about the ONS 15454 equipment, including:

- Location—Identifies where the equipment is installed, either chassis or slot number.
- Eqpt Type—Displays the type of equipment but not the specific card name, for example, OC-12 or DS-1.
- Actual Eqpt Type—Displays the specific card name, for example, OC12 IR/STM4 SH 1310.
- Admin State—Changes the card service state unless network conditions prevent the change. For more information about card administrative states, refer to the “Administrative and Service States” appendix in the *Cisco ONS 15454 DWDM Reference Manual*.
  - IS (ANSI) or Unlocked (ETSI)—Places the card in the In-Service and Normal (IS-NR [ANSI]) or Unlocked-enabled (ETSI) service state.
  - OOS,MA (ANSI) or Locked,maintenance (ETSI)—Places the card in the Out-of-Service and Autonomous, Maintenance (OOS-AU,MT [ANSI]) or Unlocked-disabled,maintenance (ETSI) service state.
- Service State—Displays the current card service state, which is an autonomously generated state that gives the overall condition of the card. Service states appear in the format: Primary State-Primary State Qualifier, Secondary State. For more information about card service states, refer to the “Administrative and Service States” appendix in the *Cisco ONS 15454 DWDM Reference Manual*.
- HW Part #—Displays the hardware part number; this number is printed on the top of the card or equipment piece.
- HW Rev—Displays the hardware revision number.
- Serial #—Displays the equipment serial number; this number is unique to each card.
- CLEI Code—Displays the Common Language Equipment Identifier code.
- Firmware Rev—Displays the revision number of the software used by the application-specific integrated circuit (ASIC) chip installed on the ONS 15454 card.
- Product ID—Displays the manufacturing product identifier for a hardware component, such as a fan tray, chassis, or card. The Product ID column displays “N/A” for equipment existing before Software Release 4.6.
- Version ID—Displays the manufacturing version identifier for a fan tray, chassis, or card. The Version ID column displays “N/A” for equipment existing before Software Release 4.6.

Buttons at the bottom of the Inventory tab are used to delete or reset a card when a card is selected, or to delete a PPM if a PPM is selected on the table.





## Numerics

### 32DMX card

- attaching fiber to patch-panel tray [3-64](#)
- changing administrative state [11-39, 11-44](#)
- changing optical channel settings [11-43](#)
- changing optical channel thresholds [11-45](#)
- changing optical line settings [11-39](#)
- changing optical line thresholds [11-41](#)
- fiber clip [3-57](#)
- installing [3-44](#)
- modifying line settings and PM thresholds [11-38](#)
- resetting [13-13](#)
- ROADM node acceptance test [4-20](#)
- routing fiber to the deep patch-panel tray [3-69](#)
- Terminal node acceptance test [4-8](#)
- terminal node acceptance test [4-8](#)
- verifying power [4-12](#)
- viewing optical power statistics [9-13](#)

### 32DMX-L card

- changing administrative state [11-44](#)
- changing optical channel settings [11-43](#)
- changing optical channel thresholds [11-45](#)
- changing optical line settings [11-39](#)
- changing optical line thresholds [11-41](#)
- installing [3-44](#)
- modifying line settings and PM thresholds [11-38](#)
- ROADM acceptance test [4-42](#)
- Terminal node acceptance test [4-13](#)
- terminal node acceptance test [4-13](#)
- verifying power [4-19](#)
- viewing optical power statistics [9-13](#)

### 32DMX-O card

- attaching fiber to patch-panel tray [3-64](#)
- changing administrative state [11-39, 11-44](#)
- changing optical channel settings [11-43](#)
- changing optical channel thresholds [11-45](#)
- changing optical line settings [11-39](#)
- changing optical line thresholds [11-41](#)
- deleting [3-41](#)
- fiber clip [3-57](#)
- installing [3-44](#)
- modifying line settings and PM thresholds [11-38](#)
- resetting [13-13](#)
- routing fiber to the deep patch-panel tray [3-69](#)
- terminal and hub node acceptance test [4-2](#)
- verifying power [4-7](#)
- viewing optical power statistics [9-13](#)

### 32MUX-O card

- attaching fiber to patch-panel tray [3-64](#)
- changing administrative state [11-39, 11-44](#)
- changing optical channel settings [11-43](#)
- changing optical channel thresholds [11-45](#)
- changing optical line settings [11-39](#)
- changing optical line thresholds [11-41](#)
- deleting [3-41](#)
- fiber clip [3-57](#)
- installing [3-44](#)
- modifying line settings and PM thresholds [11-38](#)
- resetting [13-13](#)
- routing fiber to the deep patch-panel tray [3-69](#)
- terminal and hub node acceptance test [4-2](#)
- verifying power [4-7](#)
- viewing optical power statistics [9-13](#)

### 32WSS card

- attaching fiber to patch-panel tray [3-64](#)

- changing administrative state [11-50, 11-55](#)
- changing optical channel parameters [11-49](#)
- changing optical channel thresholds [11-52](#)
- changing optical line parameters [11-55](#)
- changing optical line thresholds [11-56](#)
- deleting [3-41](#)
- installing [3-44](#)
- modifying line settings and PM thresholds [11-48](#)
- resetting [13-13](#)
- ROADM node acceptance test [4-20](#)
- routing fiber to the deep patch-panel tray [3-69](#)
- Terminal node acceptance test [4-8](#)
- terminal node acceptance test [4-8](#)
- viewing optical power statistics [9-13](#)

#### 32WSS-L card

- changing administrative state [11-50, 11-55](#)
- changing optical channel parameters [11-49](#)
- changing optical channel thresholds [11-52](#)
- changing optical line parameters [11-55](#)
- changing optical line thresholds [11-56](#)
- deleting [3-41](#)
- installing [3-44](#)
- modifying line settings and PM thresholds [11-48](#)
- ROADM node acceptance test [4-42](#)
- Terminal node acceptance test [4-13](#)
- terminal node acceptance test [4-13](#)
- viewing optical power statistics [9-13](#)

#### 4MD-xx.x card

- changing administrative state [11-39, 11-44](#)
- changing optical channel settings [11-43](#)
- changing optical channel thresholds [11-45](#)
- changing optical line settings [11-39](#)
- changing optical line thresholds [11-41](#)
- deleting [3-41](#)
- installing [3-44](#)
- modifying line settings and PM thresholds [11-38](#)
- verifying pass-through connection power [4-100](#)
- viewing optical power statistics [9-15](#)

## A

### acceptance tests

- anti-ASE hub node [4-64](#)
- C-band line amplifier node with OSC-CSM and OSCM cards [4-82](#)
- C-band line amplifier node with OSC-CSM cards [4-74](#)
- C-band line amplifier node with OSCM cards [4-66](#)
- L-band line amplifier node with OSC-CSM and OSCM cards [4-86](#)
- L-band line amplifier node with OSC-CSM cards [4-78](#)
- L-band line amplifier node with OSCM cards [4-70](#)
- ROADM node [4-20, 4-42](#)
- shelf connections [1-84](#)
- shelf installation [1-82](#)
- symmetric OADM node with OSC-CSM cards [4-102](#)
- symmetric OADM node with OSCM cards [4-90](#)
- symmetric passive OADM node with OSC-CSM cards [4-108](#)
- terminal and hub nodes with 32MUX-O and 32DMX-O cards [4-2](#)
- terminal node with 32WSS and 32DMX cards [4-8](#)
- terminal node with 32WSS-L and 32DMX-L cards [4-13](#)

accessing, TL1 craft interface [1-56](#)

### active logins

- terminating [10-61](#)
- viewing [10-61](#)

### AD-1B-xx.x card

- deleting [3-41](#)
- installing [3-44](#)
- resetting [13-13](#)
- verifying output common power [4-94](#)
- verifying output express power [4-93](#)
- verifying pass-through connection power [4-96](#)
- viewing band OADM power statistics [9-18](#)

### AD-1C-xx.x card

- adding to an OADM node [12-5](#)
- deleting [3-41](#)



- installing [3-44](#)
  - resetting [13-13](#)
  - verifying output common power [4-94](#)
  - verifying output express power [4-93](#)
  - verifying pass-through connection [4-96](#)
  - viewing channel OADM power statistics [9-16](#)
- AD-2C-xx.x card
- adding to an OADM node [12-5](#)
  - deleting [3-41](#)
  - installing [3-44](#)
  - resetting [13-13](#)
  - verifying output common power [4-94](#)
  - verifying output express power [4-93](#)
  - verifying pass-through connection [4-96](#)
  - viewing channel OADM power statistics [9-16](#)
- AD-4B-xx.x card
- deleting [3-41](#)
  - installing [3-44](#)
  - resetting [13-13](#)
  - verifying output common power [4-94](#)
  - verifying output express power [4-93](#)
  - verifying pass-through connection power [4-96](#)
  - viewing band OADM power statistics [9-18](#)
- AD-4C-xx.x card
- adding to an OADM node [12-5](#)
  - deleting [3-41](#)
  - installing [3-44](#)
  - resetting [13-13](#)
  - verifying output common power [4-94](#)
  - verifying output express power [4-93](#)
  - verifying pass-through connection [4-96](#)
  - viewing channel OADM power statistics [9-16](#)
- adding
- AD-xC-xx.x card to an OADM node [12-5](#)
  - DWDM node to a network [12-8](#)
  - firewall tunnels [7-25](#)
  - node to a domain [10-29](#)
  - node to the current session [A-6](#)
  - node to the current session or login group [2-30](#)
  - proxy tunnels [7-24](#)
  - static TID-to-NSAP entry to the TDC [3-31](#)
  - subtending shelf to a multishelf node [12-13](#)
  - TARP MAT entry [3-32, 10-12](#)
- administrative state, changing
- during ANS [3-83](#)
  - for 10G data muxponder cards [5-99](#)
  - for 10G multirate transponder cards [5-40](#)
  - for 2.5G data muxponder cards [5-80](#)
  - for 2.5G multirate transponder cards [5-20](#)
  - for 32WSS and 32WSS-L cards [11-50](#)
  - for 4x2.5G muxponder cards [5-62](#)
  - for MMU card [11-59](#)
  - for multiplexer and demultiplexer cards [11-39](#)
  - for OCHCC circuits [7-10, 7-15](#)
  - for OPT-AMP-L card [11-27](#)
  - for OPT-PRE, OPT-BST, OPT-BST-E, and OPT-BST-L cards [11-15](#)
  - for OSCM and OSC-CSM cards [11-3](#)
  - in the Inventory tab [11-65, A-14](#)
- AEP
- See also* AIC-I card
  - connecting external wire-wrap panel [1-57](#)
  - description [1-43](#)
  - installing on backplane [1-43](#)
  - pin assignments [1-46](#)
  - wire-wrap connections to backplane pins [1-45](#)
- AIC-I card
- See also* external alarms
  - See also* external controls
  - changing external alarms [11-63](#)
  - changing external controls [11-64](#)
  - changing orderwire settings [11-64](#)
  - installing [1-76](#)
  - modifying settings [11-62](#)
  - provisioning external alarms and controls [8-32](#)
  - provisioning orderwire [7-26](#)
- AINS soak
- 10G data muxponder cards [5-104](#)

- 10G multirate transponder cards [5-42](#)
  - 2.5G data muxponder cards [5-87](#)
  - 2.5G multirate transponder cards [5-21](#)
  - 32WSS and 32WSS-L cards [11-51, 11-56](#)
  - 4x2.5G muxponder cards [5-63, 5-67](#)
  - MMU card [11-60](#)
  - multiplexer and demultiplexer cards [11-44](#)
  - OSCM and OSC-CSM cards [11-4](#)
- AIP, replacing [13-35](#)
- air filter
- inspecting, cleaning, and replacing [13-22](#)
  - installing below the fan-tray assembly [1-40](#)
  - installing below the shelf assembly with external brackets [1-11](#)
  - location [1-40](#)
  - requirement [1-40](#)
- air ramp, installing [1-19](#)
- AIS threshold [6-6](#)
- alarm filtering
- disabling [8-28](#)
  - enabling [8-26](#)
  - modifying [8-26](#)
- alarm indication signal *see* AIS
- alarm profiles
- applying to cards and nodes [8-23](#)
  - applying to ports [8-21](#)
  - creating [8-17](#)
  - deleting [8-23](#)
  - downloading [8-20](#)
- alarms
- changing the maximum number of session entries [8-10](#)
  - deleting cleared alarms from display [8-14](#)
  - displaying using time zone [8-11](#)
  - filtering [8-25](#)
  - incompatibility alarms [13-31](#)
  - suppressing [8-29](#)
  - synchronizing [8-12](#)
  - troubleshooting. *See the Cisco ONS 15454 Troubleshooting Guide*
  - unsuppressing [8-31](#)
  - viewing [8-7](#)
  - viewing alarm-affected circuits [8-15](#)
  - viewing alarm counts on LCD [8-15](#)
  - viewing history [8-8](#)
- alarm severities, changing. *See* alarm profiles
- alerts [2-32, A-9](#)
- Allen key. *See* pinned hex (Allen) key
- ALS
- provisioning maintenance for transponder and muxponder cards [5-117](#)
  - changing OPT-AMP-L card settings [11-36](#)
  - changing settings [11-12](#)
  - provisioning for 10G data muxponder cards [5-99, 5-104](#)
  - provisioning for 10G multirate transponder cards [5-41](#)
  - provisioning for 2.5G data muxponder cards [5-81, 5-86](#)
  - provisioning for 4x2.5G muxponder cards [5-63, 5-67](#)
  - provisioning for OPT-BST cards [11-24](#)
  - provisioning for OSCM and OSC-CSM cards [11-12](#)
  - provisioning for the OPT-AMP-L card [11-36](#)
  - provisioning for TXP\_MR\_2.5G and TXPP\_MR\_2.5G cards [5-21](#)
- AMI [6-6](#)
- AMP champ [1-58](#)
- amplifier cards
- See* OPT-AMP-L card
  - See* OPT-BST card
  - See* OPT-BST-E card
  - See* OPT-BST-L card
  - See* OPT-PRE card
- ANS [3-82](#)
- anti-ASE acceptance test [4-64](#)
- APC. *See* automatic power control
- applying
- alarm profiles to cards and nodes [8-23](#)
  - alarm profiles to ports [8-21](#)
  - custom background image (map) [10-28](#)

- Force Y-cable or splitter protection switch [10-38](#)
- lock-on [10-40](#)
- lockout [10-40](#)
- Manual Y-cable or splitter protection switch [10-38](#)
- APR. *See* ALS
- ARP sniffing [2-16](#)
- assigning
  - port names [7-3](#)
  - user security level [3-8, 3-9](#)
- attaching
  - AEP to the backplane [1-43](#)
  - fiber. *See* installing
- audit trail
  - off-loading records [13-16](#)
  - viewing records [13-14](#)
- automatic host detection [2-16](#)
- automatic laser shutdown. *See* ALS
- automatic node setup. *See* ANS
- automatic power control
  - disabling [10-4](#)
  - enabling [10-4](#)
  - interval [6-11](#)
  - managing [10-3](#)
  - refreshing [10-5](#)

---

## B

- B8ZS [6-6](#)
- backing up the CTC database [13-2](#)
- backplane
  - AEP connections [1-45](#)
  - alarm wire connections [1-52](#)
  - alarm wire illustration [1-54](#)
  - attaching AEP [1-43](#)
  - ground location [1-34](#)
  - installing the rear cover [1-62](#)
  - IP address. *See* secure mode
  - LAN wire connections [1-55](#)
  - removing the lower cover [1-27](#)

- removing the sheet metal cover [1-27](#)
- replacing the lower cover [13-39](#)
- timing wire connections [1-54](#)
- TL1 craft interface connections [1-56](#)
- band filter OADM cards
  - See* AD-1B-xx.x cards
  - See* AD-4B-xx.x cards
- battery power monitor thresholds [3-12](#)
- battery termination [1-38](#)
- BER [6-13](#)
- BITS
  - BITS Out references [6-5, 10-47](#)
  - external alarm pin assignments (ANSI) [1-52](#)
  - external timing pin assignments (ANSI) [1-54](#)
  - external timing pin assignments (ETSI) [1-50](#)
  - facilities [6-6, 10-48](#)
  - timing setup [6-4](#)
- blade. *See* card
- bottom brackets. *See* air filter
- browsers
  - See also* Internet Explorer
  - See also* Netscape Navigator
  - register with the Java plug-in [2-5, 2-8](#)
  - required versions [2-2](#)
- bypassing proxy service [2-22](#)

---

## C

- cabinet compartment. *See* front door
- cables
  - See also* MPO cable
  - See also* fiber
  - See also* LAN cables
  - coaxial cable [1-50](#)
  - installing alarm cables [1-47, 1-52](#)
  - installing timing cables [1-50, 1-54](#)
  - installing TL1 craft interface cables [1-56](#)
  - routing power cables [1-38](#)
- card protection

*See* splitter protection

*See* Y-cable protection

## cards

*See also* cards indexed individually by name

applying alarm profiles to [8-23](#)

changing service states [11-65](#)

resetting with CTC [13-12](#)

revision number [A-14](#)

serial number [A-14](#)

viewing part numbers in CTC [A-14](#)

## card view

changing to [A-3](#)

description [A-1](#)

CAT-5 cable. *See* LAN cable

Catalyst 2950 [1-80](#)

## C band

*See also* MXP\_2.5G\_10E\_C card

*See also* TXP\_MR\_10E\_C card

line amplifier node with OSC-CSM cards acceptance test [4-74](#)

line amplifier node with OSCM and OSC-CSM cards acceptance test [4-82](#)

line amplifier node with OSCM cards acceptance test [4-66](#)

provisioning for 10G data muxponder cards [5-102](#)

provisioning for 10G multirate transponder cards [5-45](#)

provisioning for 4x2.5G muxponder cards [5-68](#)

verifying east ROADM add/drop channels [4-32](#)

verifying ROADM pass-through channels [4-24](#)

verifying west ROADM add/drop channels [4-37](#)

CD-ROM, ONS [1-iv](#)

## changing

*See also* editing

*See also* modifying

10G data muxponder administrative states [5-99, 5-103](#)

10G data muxponder client line settings [5-99](#)

10G data muxponder distance extension settings [5-101](#)

10G data muxponder Ethernet, 1G FC/FICON, or ISC/ISC3 line thresholds [5-108](#)

10G data muxponder OC-48/STM-16 settings [5-103](#)

10G data muxponder OTN settings [5-115](#)

10G data muxponder port mode [5-4](#)

10G data muxponder section trace settings [5-105](#)

10G data muxponder SONET or SDH line thresholds [5-106](#)

10G data muxponder trunk wavelength settings [5-102](#)

10G multirate transponder administrative state [5-40](#)

10G multirate transponder card settings [5-38](#)

10G multirate transponder line settings [5-40](#)

10G multirate transponder line thresholds for 10G Ethernet LAN Phy payloads [5-48](#)

10G multirate transponder line thresholds for SONET or SDH payloads [5-45](#)

10G multirate transponder OTN settings [5-54](#)

10G multirate transponder section trace settings [5-43](#)

10G multirate transponder trunk wavelength settings [5-44](#)

2.5G data muxponder administrative states [5-80, 5-86](#)

2.5G data muxponder client line settings [5-80](#)

2.5G data muxponder distance extensions settings [5-83](#)

2.5G data muxponder line settings and PM thresholds [5-79](#)

2.5G data muxponder line thresholds for 1G Ethernet or 1G FC/FICON payloads [5-92](#)

2.5G data muxponder OC-48/STM-16 settings [5-85](#)

2.5G data muxponder section trace [5-87](#)

2.5G data muxponder settings [5-3](#)

2.5G data muxponder SONET or SDH line thresholds [5-90](#)

2.5G data muxponder trunk wavelength settings [5-89](#)

2.5G multirate transponder card OTN settings [5-34](#)

2.5G multirate transponder card section trace [5-22](#)

2.5G multirate transponder card settings [5-18](#)

2.5G multirate transponder line settings [5-19](#)

2.5G multirate transponder line thresholds for 1G Ethernet or 10G FC/FICON payloads [5-27](#)

2.5G multirate transponder SONET or SDH line threshold settings [5-24](#)

- 2.5G multirate transponder trunk wavelength settings [5-23](#)
- 32WSS and 32WSS-L optical channel parameters [11-49](#)
- 32WSS and 32WSS-L optical channel thresholds [11-52](#)
- 32WSS and 32WSS-L optical line parameters [11-55](#)
- 32WSS and 32WSS-L optical line thresholds [11-56](#)
- 32WSS port administrative state [11-50](#)
- 32WSS port administrative states [11-55](#)
- 4x2.5G muxponder administrative states [5-62, 5-66](#)
- 4x2.5G muxponder line settings [5-61](#)
- 4x2.5G muxponder line thresholds [5-68](#)
- 4x2.5G muxponder OTN settings [5-75](#)
- 4x2.5G muxponder settings [5-59](#)
- 4x2.5G muxponder trunk settings [5-65](#)
- 4x2.5G muxponder trunk wavelength settings [5-67](#)
- administrative state [A-14](#)
- administrative state during ANS [3-83](#)
- alarm severities. *See* alarm profiles
- ALS settings [11-12, 11-24](#)
- amplifier card administrative states [11-15, 11-19](#)
- amplifier card optical channel threshold settings [11-20](#)
- amplifier card optical line settings [11-14](#)
- amplifier card optical line threshold settings [11-15](#)
- card service states [11-65](#)
- clock settings [10-7](#)
- CTC network access [10-18](#)
- date [10-7](#)
- DCC terminations [10-43](#)
- default network map [10-27](#)
- default router [3-16, 10-19](#)
- DHCP request recipient [10-19](#)
- DWDM node to hybrid node [10-61](#)
- external alarms [11-63](#)
- external controls [11-64](#)
- GCC terminations [10-43](#)
- general node information [10-7](#)
- heap size [2-2](#)
- IP address [3-16](#)
- IP address default for corporate LAN connection [2-21](#)
- IP settings [10-19](#)
- Java virtual memory heap size [2-2, 2-24](#)
- JRE version [2-8](#)
- LCD IP display [10-19](#)
- maximum number of entries for alarm history [8-10](#)
- MMU card administrative states [11-59](#)
- MMU card optical line parameters [11-59](#)
- MMU card optical line thresholds [11-60](#)
- multiplexer and demultiplexer administrative state [11-44](#)
- multiplexer and demultiplexer optical channel settings [11-43](#)
- multiplexer and demultiplexer optical channel thresholds [11-45](#)
- multiplexer and demultiplexer optical line settings [11-39](#)
- multiplexer and demultiplexer optical line threshold settings [11-41](#)
- multiplexer and demultiplexer port administrative state [11-39](#)
- multiplexer and demultiplexer VOA [11-44](#)
- NE defaults to allow local domains [10-28](#)
- network mask [3-16](#)
- network view background color [10-26](#)
- node access permission [10-52](#)
- node management information [10-6](#)
- node timing parameters [10-47](#)
- node timing reference [13-17](#)
- OPT-AMP-L card administrative states [11-27, 11-30](#)
- OPT-AMP-L card ALS settings [11-36](#)
- OPT-AMP-L card optical amplifier line settings [11-30](#)
- OPT-AMP-L card optical channel threshold settings [11-32](#)
- OPT-AMP-L card optical line settings [11-26](#)
- OPT-AMP-L card optical line thresholds [11-28](#)
- optical amplifier line settings [11-18](#)
- orderwire settings [11-64](#)

- OSCM and OSC-CSM card administrative states [11-3](#), [11-7](#)
- OSCM and OSC-CSM card optical line parameters [11-6](#)
- OSCM and OSC-CSM card optical line thresholds [11-8](#)
- OSCM and OSC-CSM card VOA [11-7](#)
- OSC settings [11-2](#)
- OSC thresholds [11-5](#)
- OSI routing mode [10-14](#)
- OSPF [3-21](#)
- pass-through connections to add/drop connections [10-45](#)
- passwords [10-50](#), [10-51](#), [10-54](#), [10-55](#)
- PM clearing privileges [10-52](#)
- PM display [9-2](#)
- port service state [7-25](#)
- proxy server gateway settings [10-20](#)
- rack size [1-10](#)
- security policy [10-49](#), [10-50](#)
- SNMP settings [10-64](#)
- subnet mask [10-19](#)
- table column size [A-13](#)
- table format [A-13](#)
- time zone [10-7](#)
- to card view [A-3](#)
- to multishelf view [A-2](#)
- to network view [A-3](#)
- to node view [A-2](#)
- TXP\_MR\_10G card data rate [5-38](#)
- VOA for 32WSS cards [11-51](#)
- channel filter OADM cards
  - See* AD-1C-xx.x card
  - See* AD-2C-xx.x card
  - See* AD-4C-xx.x card
- circuits
  - See also* OCHCC
  - See also* OCHNC
  - See also* overhead circuits
  - creating [7-1 to 7-30](#)
  - disabling circuit discovery [2-27](#)
  - effect of a node name change [13-5](#)
  - Repair Circuit dialog box [13-38](#)
  - states. *See* service states
- CISCO15 [2-27](#)
- Cisco MetroPlanner
  - importing the configuration file [3-38](#)
  - internal connections report [3-58](#)
  - provisioning a network [6-10](#)
  - requirement [1-65](#), [3-1](#)
  - shelf layout illustration [3-4](#)
  - shelf layout report [3-47](#)
  - traffic matrix report [6-8](#)
  - verifying reports and files [3-3](#)
- Cisco Transport Controller. *See* CTC
- cleaning
  - air filter [13-22](#)
  - fiber adaptors [13-27](#)
  - fiber connectors [13-25](#)
- clearing
  - CTC database for disaster recovery [13-4](#)
  - Force switch [13-19](#)
  - lock-on or lockout [10-41](#)
  - Manual switch [13-19](#)
  - PM count display [9-6](#)
  - selected PM counts [9-7](#)
  - Y-cable or splitter protection switch [10-39](#)
- CLEI code [A-14](#)
- CLETOP [13-27](#)
- clock
  - changing time [10-7](#)
  - resetting [1-37](#)
  - setting time [3-11](#)
- closing
  - active logins [10-61](#)
  - active Superuser sessions [10-61](#)
  - FMEC cover [1-61](#)
- coating bare power conductors [1-38](#)
- coaxial cable [1-50](#)

- columns, table. *See* tables
- common control cards
  - See* AIC-I card
  - See* MS-ISC-100T card
  - See* TCC2 card
  - See* TCC2P card
- computer. *See* PC setup
- conditions
  - displaying using time zone [8-11](#)
  - modifying filtering parameters [8-26](#)
  - viewing [8-12](#)
- configuration file (Cisco MetroPlanner) [3-38](#)
- configuring
  - Catalyst 2950 for a multishelf node [1-80](#)
  - computer for CTC software [2-1](#)
  - CTC alerts dialog box [2-32](#)
  - NMS IP address during SNMP setup [3-36](#)
  - node for RADIUS authentication [10-58](#)
  - SOCKS settings for secure mode [3-18](#)
  - TCP/IP during craft setup [2-11, 2-14, 2-15, 2-16](#)
  - TCP/IP for craft setup [2-12](#)
- connecting
  - 32DMX or 32DMX-O card to the patch panel [3-71](#)
  - 32WSS or 32MUX-O cards to the patch panel [3-65, 3-70](#)
  - cable to MIC-C/T/P [1-29, 1-51](#)
  - computer to corporate LAN port [2-21](#)
  - external wire-wrap pin to AEP [1-57](#)
  - ground to ANSI shelf [1-33](#)
  - ground to ETSI shelf [1-32](#)
  - multishelf node and subtending shelves to a Catalyst 2950 [1-80](#)
  - multishelf node and subtending shelves to an MS-ISC-100T card [1-78](#)
  - PC computer and ONS 15454 [2-10](#)
  - power to ANSI shelf [1-36](#)
  - power to ETSI shelf [1-35](#)
- consolidating network view links [10-31](#)
- converting OCHNC to OCHCC [7-15](#)
- CORBA [3-25](#)
- corporate LAN [2-21](#)
- cost [3-20, 3-21, 10-23](#)
- covers
  - See* backplane
  - See* FMEC cover
- craft connection
  - choose type [2-9](#)
  - PC and node using automatic host detection [2-16](#)
  - PC and node using DHCP [2-13](#)
  - PC and node using static IP addresses [2-11](#)
  - Solaris workstation and node [2-19](#)
- creating
  - alarm profiles [8-17](#)
  - circuits [7-1 to 7-30](#)
  - domains [10-28](#)
  - internal patchcord [3-81](#)
  - IP-over-CLNS tunnels [3-35](#)
  - J0 section traces [7-29](#)
  - logical network map [6-18](#)
  - login node groups [2-29](#)
  - new user on a single node [3-8](#)
  - new users on multiple nodes [3-9](#)
  - OCHCCs [7-4](#)
  - OCHNCs [7-11](#)
  - OCH trails [7-8](#)
  - overhead circuits [7-21](#)
  - provisionable patchcords [7-20](#)
  - static route [3-20](#)
  - user data channels [7-28](#)
- crimping cables [2-11](#)
- crimp tool [1-38](#)
- CTC
  - See also* PC setup
  - adjusting the Java virtual memory heap size [2-2](#)
  - autodiscovery of newer software releases [2-23](#)
  - changing network access [10-18](#)
  - configuring alerts dialog box [2-32](#)
  - database backup [13-2](#)
  - determine version [2-26](#)

- documenting existing provisioning [8-2](#)
- exporting data [8-4, A-6](#)
- firewall access [3-24](#)
- incompatibility alarm [2-26](#)
- installing from the CD-ROM [2-3](#)
- locking [A-6](#)
- logging in [2-23, 2-25](#)
- managing the GUI [A-5](#)
- menu options [A-5](#)
- mouse options [A-9](#)
- preventing IP address display [3-14](#)
- printing data [8-2, A-6](#)
- resetting cards [13-12](#)
- setting up computer for [2-1](#)
- setting up name, date, time, and contact information [3-10](#)
- setting up network access [3-13](#)
- toolbar icons. *See* toolbar icons
- toolbar options [A-5](#)
- verifying software release [1-75](#)
- version mismatch among multiple nodes [2-26](#)
- views. *See* network view, node view, multishelf view, card view
- customizing the network view [6-18](#)
- cutting fuse and alarm cables [1-37](#)

## D

### database

- backing up [13-2](#)
- parameters that are not backed up [13-2](#)
- parameters that are not restored [13-5](#)
- restoring [13-3](#)
- restoring node and card defaults [13-4](#)

### date

- changing setting [10-7](#)
- default [1-36](#)
- provisioning [3-11](#)

daylight savings time [3-11, 10-7](#)

DB-62 connector [1-49](#)

### DCC

- changing DCC terminations [10-43](#)
- consolidating links in network view [10-31](#)
- deleting DCC terminations [10-43](#)
- deleting terminations [14-2](#)
- disabling autodiscovery [2-27](#)
- OSI subnetwork point of attachment [10-16](#)
- provisioning DCC terminations [7-22](#)

DCN [3-27, 3-28](#)

### DCU

- attaching fiber [3-56](#)
- installing [3-49](#)
- installing the DCU chassis [1-65](#)

### default router

- changing [10-19](#)
- changing using LCD [3-16](#)
- entering IP address [3-14](#)
- initially provisioning [3-14](#)
- modifying in secure mode [10-21](#)

### deleting

*See also* removing

- alarm profiles [8-23](#)
- cleared alarms from display [8-14](#)
- DCC terminations [10-43](#)
- DWDM cards [3-41](#)
- firewall tunnels [10-25](#)
- GCC terminations [10-43](#)
- internal patchcords [3-82](#)
- IP-encapsulated tunnels [7-29](#)
- IP-over-CLNS tunnels [10-18](#)
- node (shortcut) [A-6](#)
- node from current session or login group [2-31](#)
- node from specific login node group [2-31](#)
- OCHCCs [7-8](#)
- OCHNCs [7-13](#)
- orderwire [7-29](#)
- OSC terminations [10-44](#)
- overhead circuits [7-29](#)



- PPM provisioning [5-12](#)
- PPMs [A-15](#)
- provisionable patchcords [10-45](#)
- proxy tunnels [10-25](#)
- selected nodes [A-6](#)
- SFP provisioning [5-12](#)
- SNMP trap destinations [10-66](#)
- static routes [10-24](#)
- subtending shelf from a multishelf node [12-14](#)
- terminations [14-2](#)
- user data channels [7-29](#)
- users [10-55, 10-56](#)
- Y-cable protection group [10-36](#)
- demultiplexer cards
  - See* 32DMX card
  - See* 32DMX-L card
  - See* 32DMX-O card
- dense wavelength division multiplexing. *See* DWDM
- designated intermediate system priority. *See* DIS priority
- detaching the ground strap [1-22](#)
- DHCP
  - changing IP address setting for corporate LAN connection [2-21](#)
  - changing request recipient [10-19](#)
  - configuration note [2-14](#)
  - enabling during network setup [3-14](#)
  - provisioning [2-13](#)
  - provisioning server [3-14](#)
- diagnostics file, off-loading [13-17](#)
- dialog box, do not display [10-30](#)
- disabling
  - alarm filtering [8-28](#)
  - APC [10-4](#)
  - circuit discovery [2-27](#)
  - DCC autodiscovery [2-27](#)
  - OSPF [10-24](#)
  - proxy service [2-22](#)
  - secure mode [10-22](#)
- disaster recovery [13-4](#)
- displaying
  - See also* viewing
  - alarms and conditions by time zone [8-11](#)
  - hidden table columns [A-13](#)
- DIS priority [3-35](#)
- documentation
  - audience [1-xlvii](#)
  - objectives [1-xlvii](#)
  - organization [1-xlvii](#)
  - related to this book [1-xlviii](#)
  - typographical conventions [1-xlviii](#)
- documenting existing provisioning [8-2](#)
- domains
  - description [A-2](#)
  - adding a node [10-29](#)
  - changing the NE defaults to allow local domains [10-28](#)
  - creating [10-28](#)
  - managing [10-29](#)
  - moving [10-29](#)
  - removing [10-30](#)
  - renaming [10-29](#)
- downloading
  - alarm profiles [8-20](#)
  - JAR files [2-28](#)
- DWDM
  - adding a node to a network [12-8](#)
  - monitoring performance [9-9 to 9-19](#)
  - optional hardware [1-64](#)
  - provisioning a network [6-10](#)
  - removing node from a network [12-10](#)
- DWDM cards
  - See also* 32DMX card
  - See also* 32DMX-L card
  - See also* 32DMX-O card
  - See also* 32MUX-O card
  - See also* 32WSS card
  - See also* 32WSS-L card
  - See also* 4MD-xx.x card

*See also* AD-1B-xx.x card  
*See also* AD-1C-xx.x card  
*See also* AD-2C-xx.x card  
*See also* AD-4B-xx.x card  
*See also* AD-4C-xx.x card  
*See also* MMU card  
*See also* OPT-AMP-L card  
*See also* OPT-BST card  
*See also* OPT-BST-E card  
*See also* OPT-BST-L card  
*See also* OPT-PRE card  
*See also* OSC-CSM card  
*See also* OSCM card  
 attaching fiber [3-56](#)  
 deleting [3-41](#)  
 installing [3-44](#)  
 LED behavior during installation [3-46](#)  
 removing and replacing [12-2](#)

Dynamic Host Configuration Protocol. *See* DHCP

## E

### editing

*See also* changing  
*See also* modifying  
 IP-over-CLNS tunnels [10-17](#)  
 NE defaults [13-41](#)  
 OSI router configurations [10-15](#)  
 OSI subnetwork point of attachment [10-16](#)

### EIA/TIA-232 port

accessing a TL1 craft interface [1-56](#)  
 do not use backplane pins simultaneously [1-56](#)

### enabling

alarm filtering [8-26](#)  
 APC [10-4](#)  
 DHCP during network setup [3-14](#)  
 domain creation for all users [10-28](#)  
 OSI subnet on the LAN [3-34](#)  
 OTN FEC performance monitoring [9-21](#)

OTN ITU-T G.709 performance monitoring [9-20](#)  
 secure mode [3-18](#)  
 SSM [10-48](#)

SSM for OSCM and OSC-CSM cards [11-4](#)

End System. *See* ES

End System Hello. *See* ESH

End System to Intermediate System. *See* ES-IS

entering IP address for default router [3-14](#)

environmental alarms

*See* external alarms

*See* external controls

equipment

*See also* installation

*See also* test equipment

installing DWDM equipment [1-64](#)

inventory list [A-14](#)

supplied by Cisco (ANSI) [1-3](#)

supplied by Cisco (ETSI) [1-5](#)

user-supplied (ANSI) [1-3](#)

user-supplied (ETSI) [1-5](#)

ES [3-28, 3-34](#)

ESD plug input [1-20](#)

E-Series Ethernet [10-19](#)

ESH [3-34](#)

ES-IS RIB [13-10](#)

ETR\_CLO service, verifying topologies [5-7](#)

events

*See* alarms

*See* conditions

exporting

CTC data [8-4, A-6](#)

NE defaults [13-43](#)

express channel connections [4-92, 4-104](#)

external alarms

alarm input connectors (ANSI) [1-60](#)

changing [11-63](#)

pin assignments using external wire-wrap panel [1-58](#)

pin assignments (ETSI) [1-48](#)

provisioning [8-32](#)

- wiring (ANSI) [1-52](#)
- wiring (ETSI) [1-47](#)

external brackets. *See* air filter

external controls

- alarm output connectors [1-61](#)
- changing [11-64](#)
- pin assignments using external wire-wrap panel [1-59](#)
- pin assignments (ETSI) [1-48](#)
- provisioning [8-32](#)
- wiring (ETSI) [1-47, 1-52](#)

external network element [3-15, 3-19, 10-23](#)

external switching commands

- applying a Force Y-cable or splitter protection switch [10-38](#)
- applying a lock-on [10-40](#)
- applying a lockout [10-40](#)
- applying a Manual Y-cable or splitter protection switch [10-38](#)
- clearing a lock-on or lockout [10-41](#)
- clearing a Y-cable or splitter protection switch [10-39](#)

external timing [6-4](#)

external wire-wrap panel [1-57](#)

## F

factory configuration, restoring [13-4](#)

fan-tray air filter. *See* air filter

fan-tray assembly

- installing [1-40](#)
- power cable [13-36](#)
- removing to replace air filter [13-24](#)
- replacing [13-30](#)

ferrites [1-82](#)

fiber

- cleaning adapters [13-27](#)
- cleaning connectors [13-25](#)
- fiber clips [3-57](#)
- fiber-storage tray illustration [3-57, 3-74](#)
- installing on DWDM cards and DCUs [3-56](#)

- installing on Y-cable protection modules [3-75](#)
- installing the fiber patch-panel tray [1-66](#)
- installing the fiber-storage tray [1-66](#)

fiber patch-panel tray

- deep patch-panel tray illustration [3-70](#)
- installing [1-66](#)
- routing fiber to deep patch-panel tray [3-69, 3-72](#)
- routing fiber to standard patch-panel tray [3-64, 3-68](#)
- standard patch-panel tray illustration [3-67, 3-68](#)

fiber-storage tray

- illustration [3-57, 3-74](#)
- installing [1-66](#)
- routing fiber from DWDM cards and DCUs [3-56, 3-73](#)
- routing fiber from the Y-cable modules [3-77](#)

filler cards, installing [3-55](#)

filtering

- alarms [8-25](#)
- modifying parameters [8-26](#)
- OCHNCs and OCHCCs [7-35](#)

filter stopper [1-12](#)

finding

- OCHNCs and OCHCCs [7-31](#)
- warning information [1-lv](#)

firewall

- provisioning access [3-14](#)
- provisioning IIOP listener port [3-25, 3-26](#)
- setting up [3-24](#)
- shortcut [A-6](#)

firewall tunnels

- adding [7-25](#)
- deleting [10-25](#)

flange [1-12](#)

FlexLayer

- See also* Y-cable protection
- hardware part numbers [1-69](#)
- installing FlexLayer modules [1-69](#)
- installing the FlexLayer shelf [1-68](#)
- installing Y-cable modules in FlexLayer chassis [1-70, 1-71](#)

## FMEC

- See* FMEC cover
- See* MIC-A/P FMEC
- See* MIC-C/T/P FMEC

## FMEC cover

- installing and closing [1-61](#)
- opening [1-24](#)
- removing [1-25](#)

Force switch. *See* external switching commands

## foreign node settings

- changing GCC terminations [10-43](#)
- provisioning a proxy tunnel [7-24](#)
- provisioning GCC terminations [7-22](#)
- specifying IP address [10-43](#)

frame-ground pin [1-56](#)framing [6-6, 10-48](#)

## front door

- installing ground strap retrofit kit [13-28](#)
- opening [1-20](#)
- removing [1-21](#)
- replacing [13-28](#)

## fuse and alarm panel

- measuring and cutting cables [1-37](#)
- verifying office battery and ground [1-39](#)

---

**G**

G.709. *See* OTN

gateway network element [3-15, 3-19, 10-23](#)

gateway settings. *See* proxy server

## GCC

- changing GCC terminations [10-43](#)
- consolidating links in network view [10-31](#)
- deleting GCC terminations [10-43, 14-2](#)
- foreign termination [7-24, 7-25](#)
- OSI subnetwork point of attachment [10-16](#)
- provisioning GCC terminations [7-22](#)

granting Superuser privileges to Provisioning users [10-53](#)

GRE tunnel [3-35, 10-17](#)

## ground

- connecting to ANSI shelf [1-33](#)
- connecting to ETSI shelf [1-32](#)
- installing [1-30](#)
- verifying before turning on office power [1-39](#)

## ground strap

- avoiding interference with cards [13-29](#)
- detaching [1-22](#)
- retrofit kit [13-29](#)

---

**H**

heap size, adjusting [2-2](#)

hello interval [3-22](#)

hex key. *See* pinned hex (Allen) key

hop [3-20, 10-23](#)

## hub node

- anti-ASE hub node acceptance test [4-64](#)
- converting pass-through connections [10-46](#)
- CTC icon [A-4](#)
- routing fiber [3-62](#)

hybrid node, converting from DWDM [10-61](#)

---

**I**

idle time [3-8](#)

IIH [3-35, 3-84](#)

## IIOP listener port

- provisioning on the node [3-25](#)
- provisioning on the PC [3-26](#)

## importing

- alarm profiles [8-20](#)
- Cisco MetroPlanner configuration file [3-38](#)
- NE defaults [13-42](#)

## inspecting

- air filter [13-22](#)
- shelf assembly [1-6, 1-7](#)

## installation

- acceptance test [1-82](#)
- list of procedures [1-1](#)
- required tools (ANSI) [1-3](#)
- required tools (ETSI) [1-5](#)
- installing
  - See also* mounting
  - AEP [1-43](#)
  - AIC-I card [1-76](#)
  - air filter [1-11, 1-40](#)
  - air ramp [1-19](#)
  - alarm wires on the backplane [1-52](#)
  - alarm wires on the MIC-A/P [1-47](#)
  - backplane rear cover [1-62](#)
  - browsers for CTC [2-2](#)
  - CTC for Windows PCs [2-2](#)
  - CTC from the CD-ROM [2-3](#)
  - CTC on a Solaris workstation [2-5](#)
  - DCUs [1-65, 3-49](#)
  - DCU shelf assembly [1-65](#)
  - DWDM cards [3-44](#)
  - DWDM equipment [1-64](#)
  - fan-tray assembly [1-40](#)
  - fiber on DWDM cards and DCUs [3-56](#)
  - fiber on Y-cable protection modules [3-75](#)
  - fiber patch-panel tray [1-66](#)
  - fiber-storage tray [1-66](#)
  - fiber to the patch-panel [3-64](#)
  - filler cards [3-55](#)
  - FlexLayer modules [1-69](#)
  - FlexLayer shelf [1-68](#)
  - FMEC cover [1-61](#)
  - front door ground strap retrofit kit [13-28](#)
  - ground [1-30](#)
  - JRE on a Solaris workstation [2-5](#)
  - JRE on a Windows PC [2-2](#)
  - LAN wires on the backplane [1-55](#)
  - LAN wires on the MIC-C/T/P [1-51](#)
  - MIC cards [1-28](#)
  - MS-ISC-100T card [1-77](#)
  - rear cover mounting brackets [1-63](#)
  - SFPs [3-52](#)
  - shelf assembly [1-8](#)
  - TCC2/TCC2P card [1-73](#)
  - timing wires on the backplane [1-54](#)
  - timing wires on the MIC-C/T/P [1-50](#)
  - TL1 craft interface wires [1-56](#)
  - transponder and muxponder cards [3-50](#)
  - Y-cable module tray [1-67](#)
  - Y-cable protection modules [1-70, 1-71](#)
- Intermediate System Hello. *See* ISH
- Intermediate System Level 1. *See* IS Level 1
- Intermediate System Level 1/Level 2. *See* IS Level 1/Level 2
- Intermediate System to Intermediate System. *See* IS-IS
- internal patchcord
  - creating [3-81](#)
  - deleting [3-82](#)
  - verifying [3-80](#)
- internal timing [6-7](#)
- Internet Explorer
  - See also* browser
  - disabling proxy service [2-22](#)
  - logging in [2-25](#)
- inventory [A-14](#)
- IP
  - changing settings [10-19](#)
  - provisioning IP settings [3-14](#)
- IP address
  - changing default for corporate LAN connection [2-21](#)
  - configuring for NMS during SNMP setup [3-36](#)
  - craft connection with static IP address [2-11](#)
  - default IP address for login [2-25](#)
  - dual-IP address capability. *See* secure mode
  - IP address using LCD [3-16](#)
  - modifying backplane IP settings [10-21](#)
  - preventing display in CTC [3-14](#)
  - provisioning network information [3-14](#)
  - selecting or entering for login [2-27](#)

suppressing CTC display [10-19](#)

IP-encapsulated tunnel

- deleting [7-29](#)

IP-over-CLNS tunnel

- creating [3-35](#)
- deleting [10-18](#)
- editing [10-17](#)

ISC service, verifying topologies [5-7](#)

ISH [3-35](#)

IS-IS

- cost [3-35](#)
- viewing RIB [13-9](#)

IS Level 1 [3-28](#)

IS Level 1/Level 2 [3-28, 3-29, 10-14](#)

ITU-T G.709. *See* OTN

---

## J

J0 section trace [7-29](#)

JAR files, automatic download [2-28](#)

Java

- adjusting the Java virtual memory heap size [2-24](#)
- Java plug-in security warning [2-26, 2-28](#)

JRE

- changing version [2-8](#)
- installing on a Solaris workstation [2-5](#)
- installing on a Windows PC [2-2](#)
- reinitialization requirement [13-4](#)

---

## K

Kepnut [1-22](#)

---

## L

LAN

- See also* craft connection
- See also* LAN cable

OSPF activity [3-21](#)

- provisioning default router during network setup [3-14](#)

LAN cable

- accessing a TL1 craft interface [1-56](#)
- connecting a multishelf node to a Catalyst 2950 [1-80](#)
- connecting cable to MIC-C/T/P [1-29, 1-51](#)
- connecting cable to TCC2/TCC2P card [2-10](#)
- connecting computer to corporate LAN port [2-21](#)
- connecting nodes in multishelf mode [1-78](#)
- connecting the computer to ONS 15454 [2-10](#)
- crimping cable [2-11](#)
- installing cable on MIC-C/T/P FMEC [1-51](#)
- installing LAN wires on the backplane [1-55](#)

LAP-D [3-28](#)

latitude [3-10](#)

L band

- line amplifier node with OSC-CSM cards acceptance test [4-78](#)
- line amplifier node with OSCM and OSC-CSM cards acceptance test [4-86](#)
- line amplifier node with OSCM cards acceptance test [4-70](#)
- provisioning for 10G data muxponder cards [5-102](#)
- provisioning for 10G multirate transponder cards [5-45](#)
- provisioning for 4x2.5G muxponder cards [5-68](#)
- verifying east ROADM add/drop channels [4-54](#)
- verifying ROADM node pass-through channels [4-46](#)
- verifying west ROADM add/drop channels [4-59](#)

## LCD

- changing IP address, network mask, and default router [3-16](#)
- changing IP display in CTC [10-19](#)
- modifying IP setting in secure mode [10-21](#)
- provisioning network settings [3-13](#)
- reading the software version on [3-5](#)
- suppressing IP address display [3-14](#)
- verifying software version [1-75](#)
- viewing alarm counts on [8-15](#)

line amplifier node

- hybrid, icon [A-4](#)
- verifying connections [6-3](#)
- line timing [6-4](#)
- Link State Protocol. *See* LSP
- listener port. *See* IOP listener port
- locking
  - CTC [A-6](#)
  - secure mode [10-20](#)
  - traffic [10-40](#)
- lock-on. *See* external switching commands
- lockout. *See* external switching commands
- lock washer [13-28](#)
- logging in
  - to CTC [2-23, 2-25](#)
  - using Internet Explorer [2-25](#)
  - using Netscape Navigator [2-25](#)
- logging out users
  - on a single node [10-57](#)
  - on multiple nodes [10-58](#)
- login legal disclaimer [10-8](#)
- login node groups
  - adding a node to current session [2-30](#)
  - creating [2-29](#)
  - deleting a node from a specified group [2-31](#)
  - deleting a node from the current session [2-31](#)
  - shortcut [A-6](#)
  - viewing [2-27](#)
- longitude [3-10](#)
- LSP buffers [3-28, 3-29](#)

---

## M

- MAC address
  - AIP replacement [13-37](#)
  - TXP\_MR\_10E incoming MAC address [5-42](#)
  - viewing [3-14](#)
- Maintenance user. *See* security
- managing
  - APC [10-3](#)

- CTC GUI [A-5](#)
- domains [10-29](#)
- OSI information [13-9](#)
- TDC [13-11](#)
- Manual switch. *See* external switching commands
- map. *See* network view
- measuring
  - fuse and alarm cables [1-37](#)
  - voltage [1-84](#)
- MetroPlanner. *See* Cisco MetroPlanner
- MIB
  - SNMP [3-37](#)
- MIC-A/P FMEC
  - description [1-29](#)
  - installing [1-28](#)
  - installing alarm cables [1-47](#)
  - pin connections [1-36](#)
- MIC-C/T/P FMEC
  - description [1-29](#)
  - installing [1-28](#)
  - installing LAN cables [1-51](#)
  - installing timing cables [1-50](#)
  - pin connections [1-36](#)
  - timing connectors [1-50](#)
- MMU card
  - changing administrative state [11-59](#)
  - changing optical line parameters [11-59](#)
  - changing optical line thresholds [11-60](#)
  - deleting [3-41](#)
  - installing [3-44](#)
  - verifying cabling [4-26, 4-28, 4-29, 4-30, 4-34, 4-40, 4-48, 4-50, 4-51, 4-52, 4-56, 4-62](#)
  - verifying insertion loss [4-8, 4-13, 4-20, 4-42](#)
- modifying
  - See also* changing
  - See also* editing
  - 32WSS and 32WSS-L line settings and PM thresholds [11-48](#)
  - AIC-I card settings [11-62](#)

- alarm filtering [8-26](#)
- amplifier card line settings [11-13](#)
- backplane IP settings [10-21](#)
- default router in secure mode [10-21](#)
- filtering parameters [8-26](#)
- IP settings in secure mode [10-21](#)
- multiplexer and demultiplexer line settings and PM thresholds [11-38](#)
- OSI provisioning [10-9](#)
- security settings [10-48](#)
- SNMP trap destinations [10-65](#)
- splitter protection [10-35](#)
- static routes [10-23](#)
- subnet mask in secure mode [10-21](#)
- TARP operating parameters [10-10](#)
- Y-cable protection group [10-35](#)
- module. *See* card
- monitoring
  - DWDM card performance [9-9 to 9-19](#)
  - transponder and muxponder card performance [9-19](#)
- mounting
  - multiple nodes in a rack [1-16](#)
  - shelf assembly in a rack (one person) [1-13](#)
  - shelf assembly in a rack (two people) [1-15](#)
- mounting brackets
  - installing the rear cover [1-63](#)
  - reversing the brackets to covert the rack size [1-10](#)
- moving domains [10-29](#)
- MPO cable
  - connecting a 32DMX or 32DMX-O card to the patch panel [3-67, 3-71](#)
  - connecting a 32WSS or 32MUX-O card to the patch panel [3-65, 3-70](#)
  - illustration [3-66](#)
  - routing through patch-panel tray [3-66](#)
- MS-ISC-100T card
  - connecting to a shelf [1-78](#)
  - deleting [3-41](#)
  - installing [1-77](#)
  - LED sequence [1-77](#)
  - verifying installation [3-5](#)
- MTU [3-28](#)
- multiplexer cards
  - See* 32MUX-O card
  - See* 4MD-xx.x card
- multishelf mode
  - See also* MS-ISC-100T card
  - See also* subtending shelf
  - adding a rack or shelf [12-13](#)
  - configuring a Catalyst 2950 [1-80](#)
  - connecting shelves [1-78](#)
  - connecting to a Catalyst 2950 [1-80](#)
  - corporate LAN connection [2-21](#)
  - deleting a rack or shelf [12-14](#)
  - LAN connection [2-10](#)
  - provisioning a multishelf node [3-5](#)
  - shortcuts in CTC multishelf view [A-11](#)
  - upgrading from single shelf [3-87](#)
- multishelf view
  - changing to [A-2](#)
  - description [A-2](#)
  - shortcuts [A-11](#)
- muxponder cards
  - See also* MXP\_2.5G\_10E card
  - See also* MXP\_2.5G\_10E\_C card
  - See also* MXP\_2.5G\_10E\_L card
  - See also* MXP\_2.5G\_10G card
  - See also* MXP\_MR\_10DME\_C card
  - See also* MXP\_MR\_10DME\_L card
  - See also* MXP\_MR\_2.5G card
  - See also* MXPP\_MR\_2.5G card
  - timing references [6-5](#)
  - provisioning GCC terminations [7-22](#)
  - routing fiber to the standard patch-panel tray [3-68](#)
- MXP\_2.5G\_10E\_C card
  - changing administrative state [5-62, 5-66](#)
  - changing card settings [5-59](#)
  - changing line OTN settings [5-75](#)
  - changing line settings [5-61](#)



- changing line thresholds [5-68](#)
  - changing trunk settings [5-65](#)
  - changing trunk wavelength settings [5-67](#)
  - deleting [3-41](#)
  - monitoring performance [9-19](#)
  - provisioning client port alarm and TCA thresholds [5-73](#)
  - provisioning trunk port alarm and TCA thresholds [5-71](#)
  - resetting [13-13](#)
  - viewing optics parameters [9-22](#)
  - viewing OTN parameters [9-25](#)
  - viewing payload parameters [9-23](#)
- MXP\_2.5G\_10E\_L card**
- changing administrative state [5-62, 5-66](#)
  - changing card settings [5-59](#)
  - changing line OTN settings [5-75](#)
  - changing line settings [5-61](#)
  - changing line thresholds [5-68](#)
  - changing trunk settings [5-65](#)
  - changing trunk wavelength settings [5-67](#)
  - deleting [3-41](#)
  - monitoring performance [9-19](#)
  - provisioning client port alarm and TCA thresholds [5-73](#)
  - provisioning trunk port alarm and TCA thresholds [5-71](#)
  - resetting [13-13](#)
  - viewing optics parameters [9-22](#)
  - viewing OTN parameters [9-25](#)
  - viewing payload parameters [9-23](#)
- MXP\_2.5G\_10E card**
- changing administrative state [5-62, 5-66](#)
  - changing card settings [5-59](#)
  - changing line OTN settings [5-75](#)
  - changing line settings [5-61](#)
  - changing line thresholds [5-68](#)
  - changing trunk settings [5-65](#)
  - changing trunk wavelength settings [5-67](#)
  - deleting [3-41](#)
  - installing [3-50](#)
  - monitoring performance [9-19](#)
  - provisioning client port alarm and TCA thresholds [5-73](#)
  - provisioning trunk port alarm and TCA thresholds [5-71](#)
  - resetting [13-13](#)
  - viewing optics parameters [9-22](#)
  - viewing OTN parameters [9-25](#)
  - viewing payload parameters [9-23](#)
- MXP\_MR\_10DME\_C card**
- changing administrative state [5-99, 5-103](#)
  - changing client line settings [5-99](#)
  - changing distance extension settings [5-101](#)
  - changing line thresholds for Ethernet, 1G FC/FICON, or ISC/ISC3 [5-108](#)
  - changing OC-48/STM-16 settings [5-103](#)
  - changing OTN settings [5-115](#)
  - changing section trace settings [5-105](#)
  - changing SONET or SDH line thresholds [5-106](#)
  - changing the port mode [5-4](#)

- changing trunk wavelength settings [5-102](#)
  - deleting [3-41](#)
  - installing [3-50](#)
  - monitoring performance [9-19](#)
  - provisioning client port alarm and TCA thresholds [5-112](#)
  - provisioning trunk port alarm and TCA thresholds [5-111](#)
  - resetting [13-13](#)
  - viewing optics parameters [9-22](#)
  - viewing OTN parameters [9-25](#)
  - viewing payload parameters [9-23](#)
- MXP\_MR\_10DME\_L card**
- changing administrative state [5-99, 5-103](#)
  - changing client line settings [5-99](#)
  - changing distance extension settings [5-101](#)
  - changing line thresholds for Ethernet, 1G FC/FICON, or ISC/ISC3 [5-108](#)
  - changing OC-48/STM-16 settings [5-103](#)
  - changing OTN settings [5-115](#)
  - changing section trace settings [5-105](#)
  - changing SONET or SDH line thresholds [5-106](#)
  - changing the port mode [5-4](#)
  - changing trunk wavelength settings [5-102](#)
  - deleting [3-41](#)
  - installing [3-50](#)
  - monitoring performance [9-19](#)
  - provisioning client port alarm and TCA thresholds [5-112](#)
  - provisioning trunk port alarm and TCA thresholds [5-111](#)
  - resetting [13-13](#)
  - viewing optics parameters [9-22](#)
  - viewing OTN parameters [9-25](#)
  - viewing payload parameters [9-23](#)
- MXP\_MR\_2.5G card**
- changing administrative state [5-80, 5-86](#)
  - changing card mode [5-3](#)
  - changing client line settings [5-80](#)
  - changing distance extension settings [5-83](#)
  - changing line settings and PM thresholds [5-79](#)
  - changing line thresholds for 1G Ethernet or 1G FC/FICON payloads [5-92](#)
  - changing OC-48/STM-16 settings [5-85](#)
  - changing section trace settings [5-87](#)
  - changing SONET or SDH line thresholds [5-90](#)
  - changing trunk wavelength settings [5-89](#)
  - deleting [3-41](#)
  - installing [3-50](#)
  - monitoring performance [9-19](#)
  - provisioning a UDC circuit [7-28](#)
- changing line settings and PM thresholds [5-79](#)
  - changing line thresholds for 1G Ethernet or 1G FC/FICON payloads [5-92](#)
  - changing OC-48/STM-16 settings [5-85](#)
  - changing section trace settings [5-87](#)
  - changing SONET or SDH line thresholds [5-90](#)
  - changing trunk wavelength settings [5-89](#)
  - deleting [3-41](#)
  - installing [3-50](#)
  - monitoring performance [9-19](#)
  - provisioning a UDC circuit [7-28](#)
  - provisioning client port alarm and TCA thresholds [5-95](#)
  - provisioning trunk port alarm and TCA thresholds [5-94](#)
  - resetting [13-13](#)
  - viewing optics parameters [9-22](#)
  - viewing OTN parameters [9-25](#)
  - viewing payload history parameters [9-30](#)
  - viewing payload parameters [9-23](#)
  - viewing payload SONET/SDH parameters [9-32](#)
  - viewing payload statistic parameters [9-27](#)
  - viewing payload utilization parameters [9-29](#)
- MXPP\_MR\_2.5G card**
- See also* splitter protection
- changing administrative state [5-80, 5-86](#)
  - changing card mode [5-3](#)
  - changing client line settings [5-80](#)
  - changing distance extension settings [5-83](#)
  - changing line settings and PM thresholds [5-79](#)
  - changing line thresholds for 1G Ethernet or 1G FC/FICON payloads [5-92](#)
  - changing OC-48/STM-16 settings [5-85](#)
  - changing section trace settings [5-87](#)
  - changing SONET or SDH line thresholds [5-90](#)
  - changing trunk wavelength settings [5-89](#)
  - deleting [3-41](#)
  - installing [3-50](#)
  - monitoring performance [9-19](#)
  - provisioning a UDC circuit [7-28](#)

- provisioning client port alarm and TCA thresholds [5-95](#)
- provisioning trunk port alarm and TCA thresholds [5-94](#)
- resetting [13-13](#)
- viewing optics parameters [9-22](#)
- viewing OTN parameters [9-25](#)
- viewing payload history parameters [9-30](#)
- viewing payload parameters [9-23](#)
- viewing payload SONET/SDH parameters [9-32](#)
- viewing payload statistics parameters [9-27](#)
- viewing payload utilization parameters [9-29](#)

## N

### NE defaults

- editing [13-41](#)
- enabling all user levels to create domains [10-28](#)
- exporting [13-43](#)
- granting Superuser privileges to Provisioning users [10-53](#)
- importing [13-42](#)
- restoring [13-4](#)

### Netscape Navigator

- See also* browser
- disabling proxy service [2-22](#)
- logging in [2-25](#)
- testing connection during Solaris workstation setup [2-19](#)

### networks

- adding a node [12-8](#)
- converting connections during upgrade [10-45](#)
- creating circuits [7-1 to 7-30](#)
- removing a node [12-10](#)
- setting up CTC network access [3-13](#)
- topology discovery [2-23](#)

### network time protocol [3-10](#)

### network view

- adding nodes to map. *See* domains
- applying a custom background image (map) [10-28](#)

- autodiscovery of newer software releases [2-23](#)
- changing the background color [10-26](#)
- changing the default network map [10-27](#)
- changing to [A-3](#)
- consolidating links [10-31](#)
- creating a customized network view [6-18](#)
- description [A-1](#)
- node icons [A-3](#)
- switch between TDM and DWDM network views [10-31](#)
- tasks [A-12](#)

### node

- See also* hub node
- See also* hybrid node
- See also* OADM node
- accessing behind a firewall [3-24](#)
- adding (shortcut) [A-6](#)
- adding to current session [2-30](#)
- changing management information [10-6](#)
- changing name, date, time, and contact information [10-7](#)
- changing node access permission [10-52](#)
- changing timing parameters [10-47](#)
- Cisco MetroPlanner shelf layout illustration [3-4](#)
- configuring for RADIUS authentication [10-58](#)
- deleting (shortcut) [A-6](#)
- deleting from current session [2-31](#)
- icons [A-4](#)
- removing power [14-1](#)
- secure (dual IP address) mode [3-18](#)
- setting up name, date, time, and contact information [3-10](#)
- verifying connections [6-3](#)
- verifying turn-up [6-2](#)

### nodes

- applying alarm profiles to [8-23](#)
- changing timing reference [13-17](#)

### node view

- changing to [A-2](#)
- description [A-1](#)

shortcuts [A-11](#)

non-ONS node. *See* foreign node settings

NSAP

- adding a static TID-to-NSAP entry to the TDC [3-31](#)
- adding NSAP address to TARP MAT [3-32](#)
- provisioning NSAP address in IP-over-CLNS tunnel [3-36](#)
- removing static TID-to-NSAP entry from the TDC [10-12](#)

NTP server [3-10](#)

## O

OADM node

- acceptance test [4-90, 4-102, 4-108](#)
- add an AD-xC-xx.x card to [12-5](#)
- converting pass-through connections [10-46](#)
- CTC icon [A-4](#)
- icon, hybrid [A-4](#)
- verifying add and drop connections [4-98, 4-105](#)
- verifying connections [6-3](#)
- verifying express channel connections [4-92, 4-104](#)
- verifying OSC-CSM power [4-105](#)
- verifying pass-through channel connections [4-94](#)
- viewing band OADM power statistics [9-18](#)
- viewing channel OADM power statistics [9-16](#)

obtaining

- optical networking information [1-lv](#)
- safety information [1-lv](#)
- security information [1-lv](#)
- technical support [1-lv](#)

OC-48/STM-16 settings

- changing for 10G data muxponder cards [5-103](#)
- changing for 2.5G data muxponder card [5-85](#)

OCHCC

- circuit status [7-34](#)
- client rates [7-5](#)
- converting from OCHNC [7-15](#)
- creating [7-4](#)

- deleting [7-8](#)
- filtering [7-35](#)
- finding [7-31](#)
- verifying client ports [7-3](#)
- viewing [7-32](#)
- viewing alarms [8-15](#)

### OCHNC

- circuit status [7-34](#)
- converting to OCHCC [7-15](#)
- creating [7-11](#)
- deleting [7-13](#)
- filtering [7-35](#)
- finding [7-31](#)
- viewing [7-32](#)
- viewing alarms [8-15](#)
- viewing on a span [7-37](#)

### OCH trail

- creating. *See* OCHCC
- viewing [7-32, 7-33](#)

office ground. *See* ground

office power. *See* power

### off-loading

- audit trail records [13-16](#)
- diagnostics file [13-17](#)

### opening

- FMEC cover [1-24](#)
- front door [1-20](#)
- TL1 connection [A-8](#)

### OPT-AMP-L card

- changing administrative state [11-27, 11-30](#)
- changing ALS settings [11-36](#)
- changing optical amplifier line settings [11-30](#)
- changing optical channel threshold settings [11-32](#)
- changing optical line settings [11-26](#)
- changing optical line thresholds [11-28](#)
- fiber clip [3-57](#)
- setting the card mode [11-25](#)
- verifying laser and power [4-17, 4-18](#)
- viewing optical amplifier power statistics [9-12](#)

## OPT-BST card

- changing administrative state [11-15, 11-19](#)
- changing ALS settings [11-24](#)
- changing optical amplifier line settings [11-18](#)
- changing optical channel threshold settings [11-20](#)
- changing optical line settings [11-14](#)
- changing optical line thresholds [11-15](#)
- deleting [3-41](#)
- fiber clip [3-57](#)
- installing [3-44](#)
- modifying line settings and PM thresholds [11-13](#)
- placing ports in service [12-5](#)
- placing ports out of service [12-4](#)
- resetting [13-13](#)
- verifying laser and power [4-5](#)
- viewing optical amplifier power statistics [9-12](#)

## OPT-BST-E card

- changing administrative state [11-15, 11-19](#)
- changing ALS settings [11-24](#)
- changing optical amplifier line settings [11-18](#)
- changing optical channel threshold settings [11-20](#)
- changing optical line settings [11-14](#)
- changing optical line thresholds [11-15](#)
- deleting [3-41](#)
- fiber clip [3-57](#)
- installing [3-44](#)
- modifying line settings and PM thresholds [11-13](#)
- placing ports in service [12-5](#)
- placing ports out of service [12-4](#)
- resetting [13-13](#)
- verifying laser and power [4-5](#)

## OPT-BST-L card

- changing administrative state [11-15, 11-19](#)
- changing ALS settings [11-24](#)
- changing optical amplifier line settings [11-18](#)
- changing optical channel threshold settings [11-20](#)
- changing optical line settings [11-14](#)
- changing optical line thresholds [11-15](#)
- deleting [3-41](#)

fiber clip [3-57](#)

installing [3-44](#)

modifying line settings and PM thresholds [11-13](#)

placing ports in service [12-5](#)

placing ports out of service [12-4](#)

resetting [13-13](#)

verifying laser and power [4-5, 4-17](#)

viewing optical amplifier power statistics [9-12](#)

optical channel client connections. *See* OCHCC

optical channel network connections. *See* OCHNC

optical signal-to-noise ratio. *See* OSNR

## OPT-PRE card

- changing administrative state [11-15, 11-19](#)
- changing optical amplifier line settings [11-18](#)
- changing optical channel threshold settings [11-20](#)
- changing optical line settings [11-14](#)
- changing optical line thresholds [11-15](#)
- deleting [3-41](#)
- fiber clip [3-57](#)
- installing [3-44](#)
- modifying line settings and PM thresholds [11-13](#)
- placing ports in service [12-5](#)
- placing ports out of service [12-4](#)
- resetting [13-13](#)
- verifying laser and power [4-6](#)
- viewing optical amplifier power statistics [9-12](#)

## orderwire

changing settings [11-64](#)

deleting [7-29](#)

provisioning [7-26](#)

## OSC

deleting OSC terminations [10-44, 14-2](#)

OSI subnetwork point of attachment [10-16](#)

provisioning OSC terminations [3-83](#)

## OSC-CSM card

C-band line amplifier node acceptance test [4-74, 4-82](#)

changing administrative state [11-3, 11-7](#)

changing ALS settings [11-12](#)

changing optical line parameters [11-6](#)

- changing optical line thresholds [11-8](#)
  - changing OSC settings [11-2](#)
  - changing OSC thresholds [11-5](#)
  - deleting [3-41](#)
  - fiber clip [3-57](#)
  - installing [3-44](#)
  - L-band line amplifier node acceptance test [4-78, 4-86](#)
  - provisioning a user data channel [7-28](#)
  - resetting [13-13](#)
  - symmetric OADM node acceptance test [4-102](#)
  - symmetric passive OADM node acceptance test [4-108](#)
  - verifying add and drop connections [4-105](#)
  - verifying express channel connections [4-104](#)
  - verifying incoming power [4-97](#)
  - verifying power [4-110](#)
  - verifying power on OADM nodes [4-105](#)
  - verifying transmit power [3-85](#)
  - viewing PM counts [9-10](#)
- OSCM card**
- C-band line amplifier node acceptance test [4-82](#)
  - changing administrative state [11-3, 11-7](#)
  - changing ALS settings [11-12](#)
  - changing optical line parameters [11-6](#)
  - changing optical line thresholds [11-8](#)
  - changing OSC settings [11-2](#)
  - changing OSC thresholds [11-5](#)
  - deleting [3-41](#)
  - fiber clip [3-57](#)
  - installing [3-44](#)
  - L-band line amplifier node acceptance test [4-70, 4-86](#)
  - provisioning a user data channel [7-28](#)
  - resetting [13-13](#)
  - symmetric line node acceptance test [4-66](#)
  - symmetric OADM node acceptance test [4-90](#)
  - verifying add and drop connections [4-98](#)
  - verifying transmit card [3-86](#)
  - verifying transmit power [3-85](#)
  - viewing PM counts [9-10](#)
- OSC regeneration node icon** [A-5](#)
- OSI**
- See also* TARP
  - changing routing mode [10-14](#)
  - editing router configuration [10-15](#)
  - editing subnetwork point of attachment [10-16](#)
  - enabling the OSI subnet on the LAN [3-34](#)
  - modifying provisioning [10-9](#)
  - primary area address [3-33, 3-34](#)
  - provisioning additional manual area addresses [3-33](#)
  - provisioning routers [3-32](#)
  - provisioning routing mode [3-27, 3-28](#)
  - tunneling. *See* IP-over-CLNS tunnel
  - viewing and managing information [13-9](#)
- OSNR, verifying** [6-14](#)
- OSPF**
- disabling [10-24](#)
  - setting up or changing [3-21](#)
- OTN**
- changing 10G data muxponder settings [5-115](#)
  - changing 10G multirate transponder settings [5-54](#)
  - changing 2.5G multirate transponder settings [5-34](#)
  - changing 4x2.5G muxponder settings [5-75](#)
  - enabling ITU-T G.709 performance monitoring [9-20](#)
  - enabling OTN FEC performance monitoring [9-21](#)
  - MXP\_2.5G\_10E\_C card in termination mode [5-60](#)
  - MXP\_2.5G\_10E\_L card in termination mode [5-60](#)
  - MXP\_2.5G\_10E card in termination mode [5-60](#)
  - viewing PMs [9-25](#)
- overhead circuits**
- See also* orderwire
  - See also* user data channel
  - creating [7-21](#)
  - deleting [7-29](#)
  - shortcut [A-8](#)
- 
- P**
- pass-through connections

- converting to add/drop connections [10-45](#)
  - verifying for OADM channels [4-94](#)
- passwords
  - changing [10-54, 10-55](#)
  - changing security [10-50, 10-51](#)
  - creating new user [3-8, 3-9](#)
  - first-time setup (login) [2-27](#)
- PCM [7-27](#)
- PC setup
  - See also* craft connection
  - accessing behind a firewall [3-24](#)
  - configuring PC for CTC software [2-1](#)
  - corporate LAN connection [2-21](#)
  - disabling proxy service [2-22](#)
  - installing browsers [2-2](#)
  - local craft connection [2-9](#)
  - requirements [2-3](#)
  - running the CTC installation wizard [2-2, 2-5](#)
- performance monitoring
  - See also* individual cards indexed by name
  - changing the display [9-2](#)
  - changing the PM clearing privileges [10-52](#)
  - clearing current (displayed) PM counts [9-6](#)
  - clearing specific PM counts [9-7](#)
  - PM clearing privilege [10-52](#)
  - refreshing counts at 15-minute intervals [9-2](#)
  - refreshing counts at one-day intervals [9-3](#)
  - refreshing counts for a different port [9-9](#)
  - setting auto-refresh interval [9-8](#)
  - threshold crossing alert. *See* TCA
  - viewing far-end PM counts [9-5](#)
  - viewing near-end PM counts [9-4](#)
  - viewing optics parameters on transponder and muxponder cards [9-22](#)
- pin assignments
  - AEP [1-46](#)
  - craft interface (ANSI) [1-57](#)
  - external alarms and controls (ANSI) [1-53](#)
  - external alarms and controls (ETSI) [1-48](#)
  - LAN (ANSI) [1-55](#)
  - LAN (ETSI) [1-51](#)
  - power and ground on the MIC-A/P [1-36](#)
  - power and ground on the MIC-C/T/P [1-36](#)
  - timing (ANSI) [1-54](#)
  - timing (ETSI) [1-50](#)
  - wire-wrap panel on the AEP [1-58, 1-59](#)
- pinned hex (Allen) key
  - mounting shelves [1-13, 1-15, 1-16](#)
  - opening the front door [1-20](#)
- plug-in unit. *See* card
- ports
  - See also* PPMs
  - applying alarm profiles to [8-21](#)
  - assigning names [7-3](#)
  - default UDP for SNMP [3-37](#)
  - default UDP port for SNMP [10-65](#)
  - listener port. *See* IIOP listener port
  - placing ports in or out of service [7-25](#)
- power
  - See also* ground
  - BAT1 backplane power terminal [1-38](#)
  - coating bare conductors [1-38](#)
  - connecting office power to ANSI shelf [1-36](#)
  - connecting office power to ETSI shelf [1-35](#)
  - measuring voltage [1-84](#)
  - RET2 backplane power terminal [1-38](#)
  - routing cables [1-38](#)
  - setting power monitor thresholds [3-12](#)
  - turning on and verifying office power [1-39](#)
  - verifying 32DMX card power [4-12](#)
  - verifying 32DMX-L card power [4-19](#)
  - verifying 32DMX-O card power [4-7](#)
  - verifying 32MUX-O card power [4-7](#)
  - verifying OPT-BST amplifier power [4-5](#)
  - verifying OPT-BST-L and OPT-AMP-L amplifier laser and power [4-17](#)
  - verifying OPT-PRE amplifier power [4-6](#)
  - verifying OSC-CSM incoming power [4-97](#)

- verifying OSCM and OSC-CSM card transmit power [3-85](#)
  - verifying the OPT-AMP-L card power [4-18](#)
  - viewing ROADM node power equalization [10-5](#)
- power down the node [14-1](#)
- PPMs
  - See also* SFPs
  - deleting [A-15](#)
  - deleting provisioning [5-12](#)
  - preprovisioning [3-53](#)
  - provisioning a multirate PPM [5-6](#)
  - provisioning the optical line rate [5-9](#)
  - verifying for Y-cable protection provisioning [5-15](#)
- preprovisioning
  - See also* provisioning
  - card slots [3-42](#)
  - PPMs [3-53](#)
  - slots (shortcut) [A-12](#)
- preventing IP address display in CTC [3-14](#)
- printing CTC data [8-2](#), [A-6](#)
- protecting
  - one client signal with Y-cable protection [3-76](#)
  - two client signals with Y-cable protection [3-76](#)
- protection, card
  - See* splitter protection
  - See* Y-cable protection
- protocols
  - DHCP [3-14](#)
  - NTP [3-11](#)
  - SNTP [3-10](#)
- provisionable patchcord
  - consolidating links in network view [10-31](#)
  - creating [7-20](#)
  - deleting [10-45](#)
  - verifying [7-18](#)
- provisioning
  - See also* preprovisioning
  - 10G data muxponder cards [5-97 to 5-117](#)
  - 10G multirate transponder cards [5-37 to 5-45](#)
  - 2.5G data muxponder cards [5-79 to 5-89](#)
  - 4x2.5G muxponder cards [5-58 to 5-68](#)
  - ALS settings [5-117](#), [11-12](#), [11-24](#), [11-36](#)
  - DCC terminations [7-22](#)
  - DHCP [2-13](#)
  - DHCP server [3-14](#)
  - documenting existing [8-2](#)
  - DWDM networks [6-10](#)
  - external alarms and controls [8-32](#)
  - GCC terminations [7-22](#)
  - IOP listener port [3-25](#)
  - IP settings [3-14](#)
  - multishelf nodes [3-5](#)
  - network settings from the LCD [3-13](#)
  - networks using Cisco MetroPlanner [6-10](#)
  - node date [3-11](#)
  - NSAP addresses in IP-over-CLNS tunnels [3-36](#)
  - orderwire [7-26](#)
  - OSCM and OSC-CSM cards [11-4](#)
  - OSC terminations [3-83](#)
  - OSI [3-27](#)
  - OSI manual area addresses [3-33](#)
  - OSI parameters [10-9](#)
  - OSI routers [3-32](#)
  - PPMs [5-6 to 5-13](#)
  - proxy server gateway settings [3-15](#)
  - proxy tunnels [7-24](#)
  - subnet mask in a static route [3-20](#)
  - TARP parameters [3-29](#)
  - time zone [3-11](#)
  - TXP\_MR\_10E\_C card for acceptance testing [4-4](#)
  - TXP\_MR\_10E\_L card for acceptance testing [4-16](#)
  - TXP\_MR\_2.5G and TXPP\_MR\_2.5G cards [5-17 to 5-24](#)
  - user data channels [7-28](#)
  - Y-cable protection group [5-14](#)
- Provisioning user. *See* security
- proxy server
  - configuring SOCKS settings for secure mode [3-18](#)



- gateway settings, changing [10-20](#)
  - provisioning gateway settings [3-15](#)
  - provisioning settings [3-14](#)
  - provisioning SOCKS [3-15](#)
  - proxy service
    - bypassing using Internet Explorer [2-22](#)
    - bypassing using Netscape [2-22](#)
    - disabling using Internet Explorer [2-22](#)
    - disabling using Netscape [2-22](#)
  - proxy tunnels
    - adding [7-24](#)
    - deleting [10-25](#)
  - public-key security certificate [2-28](#)
  - pulse code modulation [7-27](#)
- 
- R**
- rack
    - converting the rack size [1-10](#)
    - mounting a single node [1-13, 1-15](#)
    - mounting multiple nodes [1-16](#)
  - RADIUS, configuring [10-58](#)
  - raising
    - See also* suppressing
    - alarms [8-31](#)
  - RAM
    - PC requirements for CTC [2-3](#)
    - Solaris workstation requirements for CTC [2-6](#)
  - refreshing
    - APC [10-5](#)
    - PM counts at 15-minute intervals [9-2](#)
    - PM counts at one-day intervals [9-3](#)
    - PM counts for a different port [9-9](#)
  - reinitialization tool
    - overview [13-4](#)
    - UNIX [13-7](#)
    - Windows [13-5](#)
  - removing
    - See also* deleting
    - amplifier ports from service [12-4](#)
    - backplane lower cover [1-27](#)
    - backplane sheet metal cover [1-27](#)
    - domains [10-30](#)
    - DWDM cards [12-2](#)
    - fan-tray assembly [13-24](#)
    - FMEC cover [1-25](#)
    - front door [1-21](#)
    - node from a network [12-10](#)
    - SFPs [3-54](#)
    - static TID-to-NSAP entry from the TDC [10-12](#)
    - subtending shelf from a multishelf node [12-14](#)
    - TARP MAT entry [10-13](#)
  - renaming domains [10-29](#)
  - repeater mode
    - IP address after changing from secure mode [10-22](#)
  - replacing
    - AIP [13-35](#)
    - air filter [13-22](#)
    - DWDM cards [12-2](#)
    - fan-tray assembly [13-30](#)
    - front door [13-28](#)
    - lower backplane cover [13-39](#)
  - resetting
    - cards using CTC [13-12](#)
    - TCC2/TCC2P card clock [1-37](#)
  - resizing table columns [A-13](#)
  - restoring
    - CTC database [13-3](#)
    - factory configuration [13-4](#)
    - NE defaults [13-4](#)
    - NE defaults in UNIX [13-7](#)
    - node and card defaults [13-4](#)
  - Retrieve user. *See* security
  - reversing the mounting brackets [1-10](#)
  - revertive switching [5-16](#)
  - revertive timing [6-5](#)
  - RIP [3-23](#)
  - RMON

*See also* SNMP

## ROADM

- CTC node icons [A-4](#)
- node acceptance test [4-20, 4-42](#)
- routing fiber [3-62](#)
- verifying C-band pass-through channels [4-24](#)
- verifying east C-band add/drop channels [4-32](#)
- verifying east L-band add/drop channels [4-54](#)
- verifying L-band pass-through channels [4-46](#)
- verifying west C-band add/drop channels [4-37](#)
- verifying west L-band add/drop channels [4-59](#)
- viewing node power equalization [10-5](#)

## routing

- fiber between DWDM cards and transponder/muxponder cards [3-62](#)
- fiber from DWDM cards and DCUs to fiber-storage tray [3-56, 3-73](#)
- fiber from the Y-cable modules [3-77](#)
- fiber from transponder/muxponder cards to the patch panel [3-68](#)
- fiber to standard patch panel [3-64](#)
- fiber to the deep patch-panel tray [3-69, 3-72](#)
- MPO cable through patch panel [3-66](#)
- power cables [1-38](#)

Routing Information Protocol. *See* RIP

## S

safety, obtaining information about [1-lv](#)

## SD BER

- provisioning for 10G data muxponder cards [5-104, 5-115](#)
- provisioning for 10G multirate transponder cards [5-41, 5-55](#)
- provisioning for 2.5G data muxponder cards [5-86](#)
- provisioning for 2.5G multirate transponder cards [5-20](#)
- provisioning for 4x2.5G muxponder cards [5-62, 5-76](#)
- provisioning for OSCM and OSC-CSM cards [11-4](#)

searching. *See* finding

## section trace

- changing for 10G data muxponder cards [5-105](#)
- changing for 10G multirate transponder cards [5-43](#)
- changing for 2.5G data muxponder cards [5-87](#)
- changing for 2.5G multirate transponder cards [5-22](#)
- creating a J0 section trace [7-29](#)

## secure mode

- disabling [10-22](#)
- enabling [3-18](#)
- locking [10-20](#)
- TCC2P card requirement [3-18](#)

## security

*See also* audit trail

*See also* secure mode

- assigning user security level [3-8, 3-9](#)
- changing policy [10-49, 10-50](#)
- changing security level [10-54, 10-55](#)
- first-time login information [2-27](#)
- idle times [3-8](#)
- logging out users [10-57, 10-58](#)
- modifying settings [10-48](#)
- obtaining information about [1-lv](#)

selecting login IP address [2-27](#)

## service states

*See also* administrative state

- changing port service state [7-25](#)
- changing the card service state [11-65](#)
- circuit states list [7-33](#)
- viewing [A-14](#)

## setting

- battery power monitor thresholds [3-12](#)
- clock [3-11, 10-7](#)
- OPT-AMP-L card mode [11-25](#)
- PM auto-refresh [9-8](#)

## setting up

- computer for CTC [2-1](#)
- craft connection with static IP addresses [2-11](#)
- CTC network access [3-13](#)
- external timing [6-4](#)

- firewall access [3-24](#)
- internal timing [6-7](#)
- name, date, time, and contact information [3-10](#)
- nodes automatically [3-82](#)
- OSPF [3-21](#)
- passwords for first CTC use [2-27](#)
- PC for a corporate LAN connection [2-21](#)
- proxy tunnels [7-24](#)
- SNMP [3-36](#)
- Solaris workstation for craft connection [2-19](#)
- subtending shelf in a multishelf node [3-6, 3-89](#)
- timing [6-4](#)
- SF BER
  - 10G multirate transponder cards [5-41, 5-55](#)
  - 2.5G multirate cards [5-20](#)
  - provisioning for 10G data muxponder cards [5-103, 5-115](#)
  - provisioning for 2.5G data muxponder cards [5-86](#)
  - provisioning for 4x2.5G muxponder cards [5-62, 5-76](#)
  - provisioning for OSCM and OSC-CSM cards [11-4](#)
- SFPs
  - See also* PPMs
  - deleting provisioning [5-12](#)
  - installing [3-52](#)
  - removing [3-54](#)
- shelf assembly
  - See also* installation
  - FlexLayer shelf assembly illustration [1-70](#)
  - inspecting [1-7](#)
  - installing [1-8](#)
  - installing the DCU shelf assembly [1-65](#)
  - mounting in a rack [1-13, 1-15, 1-16](#)
  - unpacking and inspecting [1-6](#)
  - verifying [1-7](#)
- shell
  - access [10-52](#)
  - programs [10-52](#)
- Simple Network Time Protocol. *See* SNTP
- slots
  - AIC-I card [3-5](#)
  - MS-ISC-100T card [3-5](#)
  - preprovisioning (shortcut) [A-12](#)
  - preprovisioning card slots [3-42](#)
  - preprovisioning SFP and XFP slots [3-53](#)
- SNMP
  - changing settings [10-64](#)
  - deleting trap destinations [10-66](#)
  - modifying trap destination [10-65](#)
  - setting up [3-36](#)
- SNTP [3-10](#)
- SOCKS. *See* proxy server
- software
  - See also* CTC
  - backing up [13-2](#)
  - CTC autodiscovery of newer releases [2-23](#)
  - verifying software version [1-75](#)
- Solaris workstation
  - configuring workstation for CTC software [2-1](#)
  - connecting cable to ONS 15454 [2-10](#)
  - connecting LAN cable to corporate LAN port [2-21](#)
  - disabling proxy service [2-22](#)
  - requirements [2-6](#)
  - running the CTC installation wizard [2-5](#)
  - setting up a craft connection [2-19](#)
- span loss, verifying [10-2](#)
- specifying foreign node IP addresses [10-43](#)
- splitter protection
  - definition [5-15](#)
  - modifying [10-35](#)
  - protection switches [10-37](#)
- SSM
  - enable [6-6](#)
  - enabling [10-48](#)
  - enabling for OSCM and OSC-CSM cards [11-4](#)
  - message set [6-5, 10-47](#)
- standard constant [3-25](#)
- standoff kit [1-12](#)
- static route

- creating [3-20](#)
  - deleting [10-24](#)
  - modifying [10-23](#)
  - RIP prerequisite [3-23](#)
- straight-through cable. *See* LAN cable
- subnet mask
- changing [10-19](#)
  - modifying in secure mode [10-21](#)
  - OSPF area range table [3-22](#)
  - provisioning in a static route [3-20](#)
  - provisioning subnet mask length during network setup [3-14](#)
  - Windows setup [2-12, 2-13](#)
- subtending shelf
- adding to a multishelf node [12-13](#)
  - connecting to an MS-ISC-100T card [1-78](#)
  - removing from a multishelf node [12-14](#)
  - setting up in multishelf node [3-6, 3-89](#)
  - upgrading from single shelf [3-87](#)
- Superuser
- changing node access and PM clearing privileges [10-52](#)
  - changing node security policies [10-49, 10-50](#)
  - changing user password and security levels [10-54, 10-55](#)
  - creating a consistent network view for all users [6-18](#)
  - deleting users [10-56](#)
  - granting Superuser privileges to Provisioning users [10-53](#)
  - logging out users [10-57, 10-58](#)
  - terminating active sessions [10-61](#)
- suppressing
- See also* raising
  - alarms [8-29](#)
  - IP address in CTC display [10-19](#)
  - LCD IP address display [3-14](#)
- switch
- See* external switching commands
  - See* timing
- switching
- between TDM and DWDM network views [10-31](#)
  - node timing reference [13-18](#)
  - synchronizing alarms [8-12](#)
- 
- ## T
- tables
- See also* List of Tables
  - changing format [A-13](#)
  - displaying hidden columns [A-13](#)
  - printing data [8-2](#)
  - resizing columns [A-13](#)
  - sort [A-13](#)
- TARP
- adding a static TID-to-NSAP entry to the TDC [3-31](#)
  - adding MAT entry [3-32, 10-12](#)
  - managing TDC [13-11](#)
  - modifying TARP operating parameters [10-10](#)
  - provisioning operating parameters [3-29](#)
  - removing MAT entry [10-13](#)
  - removing static TID-to-NSAP entry from the TDC [10-12](#)
- TARP data cache. *See* TARP
- TCA, provisioning thresholds
- for 10G data muxponder cards [5-111, 5-112](#)
  - for 10G multirate transponder cards [5-51, 5-52](#)
  - for 2.5G data muxponder cards [5-94, 5-95](#)
  - for 2.5G multirate transponder cards [5-28, 5-30](#)
  - for 4x2.5G muxponder cards [5-71, 5-73](#)
- TCC2 card
- See also* EIA/TIA-232 port
  - clearing the database for disaster recovery [13-4](#)
  - clock reset [1-37](#)
  - database backup [13-2](#)
  - installing [1-73](#)
  - LAN port [2-10](#)
  - LED sequence [1-73](#)
  - reboot behavior [3-15](#)
  - restoring the database [13-3](#)

- soft reset [13-12](#)
- verifying installation [3-4](#)
- TCC2P card
  - See also* EIA/TIA-232 port
  - See also* secure mode
  - clearing the database for disaster recovery [13-4](#)
  - clock reset [1-37](#)
  - database backup [13-2](#)
  - installing [1-73](#)
  - LAN port [2-10](#)
  - LED sequence [1-74](#)
  - reboot behavior [3-15](#)
  - restoring the database [13-3](#)
  - soft reset [13-12](#)
  - verifying installation [3-4](#)
- TCP/IP, configuring
  - for Windows 2000 [2-12, 2-15, 2-18](#)
  - for Windows 98 [2-11, 2-14, 2-16](#)
  - for Windows NT [2-12, 2-15, 2-17](#)
  - for Windows XP [2-13, 2-15, 2-18](#)
- TDC. *See* TARP
- TDM
  - node icon [A-4](#)
  - switching between TDM and DWDM network views [10-31](#)
- technical support, obtaining [1-iv](#)
- terminal lug [13-28, 13-29](#)
- terminal node
  - acceptance test [4-8, 4-13](#)
  - CTC icons [A-5](#)
  - hybrid, icon [A-4](#)
  - routing fiber [3-62](#)
- terminating. *See* closing
- test equipment
  - See also* voltmeter
  - required for ANSI installation [1-4](#)
  - required for ETSI installation [1-6](#)
- testing
  - anti-ASE hub node [4-64](#)
  - C-band line amplifier node [4-66, 4-74, 4-82](#)
  - hub node [4-2](#)
  - L-band line amplifier node [4-70, 4-78, 4-86](#)
  - Mozilla connection during Solaris workstation setup [2-19](#)
  - OADM node [4-90](#)
  - ROADM node [4-20, 4-42](#)
  - symmetric OADM node [4-102](#)
  - symmetric passive OADM node [4-108](#)
  - terminal node [4-2, 4-8, 4-13](#)
  - Y-cable protection switching [6-15](#)
- threshold crossing alert. *See* TCA
- timed out. *See* idle time
- time zone
  - changing [10-7](#)
  - displaying alarms and conditions using [8-11](#)
  - provisioning [3-11](#)
- timing
  - BITS. *See* BITS
  - changing node timing parameters [10-47](#)
  - changing node timing reference [13-17](#)
  - clearing a Manual or Force switch [13-19](#)
  - installing timing cables on ETSI shelf [1-50](#)
  - mode [6-5](#)
  - NE reference [6-5](#)
  - setting node clock [3-11](#)
  - setting up external [6-4](#)
  - setting up internal [6-7](#)
  - setting up line [6-4](#)
  - switching a reference [13-18](#)
  - viewing report [13-19](#)
- TL1
  - craft interface connection [1-56](#)
  - EIA/TIA-232 port connection [1-56](#)
  - opening a session [A-8](#)
  - pin assignments [1-57](#)
- toolbar icons
  - add node [A-6](#)
  - delete selected node [A-6](#)

- export [A-6](#)
- go to home view [A-7](#)
- go to network view [A-7](#)
- go to next view [A-7](#)
- go to other node [A-7](#)
- go to parent view [A-7](#)
- go to previous view [A-7](#)
- go to selected object view [A-7](#)
- lock node [A-6](#)
- open TL1 connection [A-8](#)
- preferences [A-6](#)
- print [A-6](#)
- zoom in [A-7](#)
- zoom in selected area [A-7](#)
- tools
  - required for ANSI installation [1-3, 1-4](#)
  - required for ETSI installation [1-6](#)
- trace route [2-11, 2-16](#)
- transponder cards
  - See also* TXP\_MR\_10E card
  - See also* TXP\_MR\_10E\_C card
  - See also* TXP\_MR\_10G card
  - See also* TXP\_MR\_2.5G card
  - See also* TXP\_MR\_10E\_L card
  - See also* TXPP\_MR\_2.5G card
  - provisioning GCC terminations [7-22](#)
  - routing fiber to the standard patch-panel tray [3-68](#)
- trap [3-37](#)
- tunnels
  - See* firewall tunnels
  - See* IP-encapsulated tunnel
  - See* IP-over-CLNS tunnel
- turning on office power [1-39](#)
- TXP\_MR\_10E\_C card
  - changing administrative state [5-40](#)
  - changing card settings [5-38](#)
  - changing line settings [5-40](#)
  - changing line thresholds for 10G Ethernet LAN Phy payloads [5-48](#)
  - changing line thresholds for SONET or SDH payloads [5-45](#)
  - changing OTN settings [5-54](#)
  - changing section trace settings [5-43](#)
  - changing trunk wavelength settings [5-44](#)
  - deleting [3-41](#)
  - monitoring performance [9-19](#)
  - provisioning ALS [5-41](#)
  - provisioning client port alarm [5-52](#)
  - provisioning client port alarm and TCA thresholds [5-52](#)
  - provisioning for acceptance testing [4-16](#)
  - provisioning TCA thresholds [5-52](#)
  - provisioning trunk port alarm and TCA thresholds [5-51](#)
  - viewing optics parameters [9-22](#)
  - viewing OTN parameters [9-25](#)
- changing line thresholds for SONET or SDH payloads [5-45](#)
- changing OTN settings [5-54](#)
- changing section trace settings [5-43](#)
- changing trunk wavelength settings [5-44](#)
- deleting [3-41](#)
- monitoring performance [9-19](#)
- provisioning ALS [5-41](#)
- provisioning client port alarm [5-52](#)
- provisioning client port alarm and TCA thresholds [5-52](#)
- provisioning for acceptance testing [4-4](#)
- provisioning TCA thresholds [5-52](#)
- provisioning trunk port alarm and TCA thresholds [5-51](#)
- viewing optics parameters [9-22](#)
- viewing OTN parameters [9-25](#)
- viewing payload parameters [9-23](#)
- TXP\_MR\_10E\_L card
  - changing administrative state [5-40](#)
  - changing card settings [5-38](#)
  - changing line settings [5-40](#)
  - changing line thresholds for 10G Ethernet LAN Phy payloads [5-48](#)
  - changing line thresholds for SONET or SDH payloads [5-45](#)
  - changing OTN settings [5-54](#)
  - changing section trace settings [5-43](#)
  - changing trunk wavelength settings [5-44](#)
  - deleting [3-41](#)
  - monitoring performance [9-19](#)
  - provisioning ALS [5-41](#)
  - provisioning client port alarm [5-52](#)
  - provisioning client port alarm and TCA thresholds [5-52](#)
  - provisioning for acceptance testing [4-16](#)
  - provisioning TCA thresholds [5-52](#)
  - provisioning trunk port alarm and TCA thresholds [5-51](#)
  - viewing optics parameters [9-22](#)
  - viewing OTN parameters [9-25](#)

- viewing payload parameters [9-23](#)
- TXP\_MR\_10E card
  - changing administrative state [5-40](#)
  - changing card settings [5-38](#)
  - changing line settings [5-40](#)
  - changing line thresholds for 10G Ethernet LAN Phy payloads [5-48](#)
  - changing line thresholds for 1G Ethernet or 1G FC/FICON payloads [5-27](#)
  - changing line thresholds for SONET or SDH payloads [5-45](#)
  - changing OTN settings [5-54](#)
  - changing section trace settings [5-43](#)
  - changing trunk wavelength settings [5-44](#)
  - deleting [3-41](#)
  - installing [3-50](#)
  - monitoring performance [9-19](#)
  - provisioning ALS [5-41](#)
  - provisioning client port alarm and TCA thresholds [5-52](#)
  - provisioning trunk port alarm and TCA thresholds [5-51](#)
  - resetting [13-13](#)
  - viewing optics parameters [9-22](#)
  - viewing OTN parameters [9-25](#)
  - viewing payload parameters [9-23](#)
- TXP\_MR\_10G card
  - changing administrative state [5-40](#)
  - changing card settings [5-38](#)
  - changing line settings [5-40](#)
  - changing line thresholds for 10G Ethernet LAN Phy payloads [5-48](#)
  - changing line thresholds for 1G Ethernet or 1G FC/FICON payloads [5-27](#)
  - changing line thresholds for SONET or SDH payloads [5-45](#)
  - changing OTN settings [5-54](#)
  - changing section trace settings [5-43](#)
  - changing the data rate [5-38](#)
  - changing trunk wavelength settings [5-44](#)
  - deleting [3-41](#)
  - installing [3-50](#)
  - monitoring performance [9-19](#)
  - provisioning ALS [5-41](#)
  - provisioning client port alarm and TCA thresholds [5-52](#)
  - provisioning trunk port alarm and TCA thresholds [5-51](#)
  - resetting [13-13](#)
  - viewing optics parameters [9-22](#)
  - viewing OTN parameters [9-25](#)
  - viewing payload parameters [9-23](#)
- TXP\_MR\_2.5G card
  - changing administrative state [5-20](#)
  - changing card settings [5-18](#)
  - changing line settings [5-19](#)
  - changing OTN settings [5-34](#)
  - changing section trace settings [5-22](#)
  - changing SONET or SDH line threshold settings [5-24](#)
  - changing trunk wavelength settings [5-23](#)
  - deleting [3-41](#)
  - installing [3-50](#)
  - monitoring performance [9-19](#)
  - provisioning ALS [5-21](#)
  - provisioning client port alarm and TCA thresholds [5-30](#)
  - provisioning trunk port alarm and TCA thresholds [5-28](#)
  - resetting [13-13](#)
  - viewing optics parameters [9-22](#)
  - viewing OTN parameters [9-25](#)
  - viewing payload parameters [9-23](#)
- TXPP\_MR\_2.5G card
  - See also* splitter protection
  - changing administrative state [5-20](#)
  - changing card settings [5-18](#)
  - changing line settings [5-19](#)
  - changing OTN settings [5-34](#)
  - changing section trace settings [5-22](#)
  - changing SONET or SDH line threshold settings [5-24](#)
  - changing trunk wavelength settings [5-23](#)

- deleting [3-41](#)
- installing [3-50](#)
- monitoring performance [9-19](#)
- provisioning ALS [5-21](#)
- provisioning client port alarm and TCA thresholds [5-30](#)
- provisioning trunk port alarm and TCA thresholds [5-28](#)
- resetting [13-13](#)
- viewing optics parameters [9-22](#)
- viewing OTN parameters [9-25](#)
- viewing payload parameters [9-23](#)

---

## U

- UNIX, restoring NE defaults [13-7](#)
- unpacking the shelf assembly [1-6](#)
- unsuppressing. *See* raising
- upgrading. *See* converting
- upgrading to a multishelf configuration [3-87](#)
- user data channel
  - creating [7-28](#)
  - deleting [7-29](#)
- users
  - See also* security
  - changing password or security settings [10-54, 10-55](#)
  - creating on a single node [3-8](#)
  - creating on multiple nodes [3-9](#)
  - deleting [10-55, 10-56](#)
  - logging out [10-57, 10-58](#)
  - user name for first login [2-27](#)
- 32MUX-O card power [4-7](#)
- 4MD-xx.x card pass-through connections [4-100](#)
- AD-xB-xx.x card output common power [4-94](#)
- AD-xB-xx.x card output express power [4-93](#)
- AD-xB-xx.x pass-through connection power [4-96](#)
- ADxC-xx.x card output common power [4-94](#)
- AD-xC-xx.x card output express power [4-93](#)
- AD-xC-xx.x pass-through connections [4-96](#)
- Cisco MetroPlanner reports and files [3-3](#)
- east ROADM C-band add/drop channels [4-32](#)
- east ROADM L-band add/drop channels [4-54](#)
- ground [1-39](#)
- internal patchcords [3-80](#)
- MMU card cabling [4-26, 4-28, 4-29, 4-30, 4-34, 4-40, 4-48, 4-50, 4-51, 4-52, 4-56, 4-62](#)
- MMU card insertion loss [4-8, 4-13, 4-20, 4-42](#)
- MS-ISC-100T card installation [3-5](#)
- node connections [6-3](#)
- node turn-up [6-2](#)
- OADM node add and drop connections [4-98, 4-105](#)
- OADM node express channel connections [4-92, 4-104](#)
- OADM node pass-through channel connections [4-94](#)
- OCHCC client ports [7-3](#)
- office power [1-39](#)
- OPT-AMP-L card laser and power [4-18](#)
- OPT-BST card laser and power [4-5](#)
- OPT-BST-L and OPT-AMP-L card laser and power [4-17](#)
- OPT-BST-L card laser and power [4-17](#)
- OPT-PRE card laser and power [4-6](#)
- OSC-CSM card incoming power [4-97](#)
- OSC-CSM card power [4-110](#)
- OSC-CSM power on OADM nodes [4-105](#)
- OSCM and OSC-CSM card transmit power [3-85](#)
- OSNR [6-14](#)
- PPMs for Y-cable protection [5-15](#)
- provisionable patchcords [7-18](#)
- ROADM node C-band pass-through channels [4-24](#)
- ROADM node L-band pass-through channels [4-46](#)

---

## V

- variable optical attenuator. *See* VOA
- verifying
  - 32DMX card power [4-12](#)
  - 32DMX-L card power [4-19](#)
  - 32DMX-O card power [4-7](#)



shelf assembly [1-7](#)

shelf ground and power [1-84](#)

software version [1-75](#)

span loss [10-2](#)

TCC2/TCC2P card installation [3-4](#)

topologies for ETR\_CLP and ISC services [5-7](#)

west ROADM C-band add/drop channels [4-37](#)

west ROADM L-band add/drop channels [4-59](#)

viewing

- See also* displaying
- 32WSS and 32WSS-L card optical power statistics [9-13](#)
- 4MD-xx.x card optical power statistics [9-15](#)
- active logins [10-61](#)
- alarm-affected circuits [8-15](#)
- alarm counts on LCD [8-15](#)
- alarm history [8-8](#)
- alarms [8-7](#)
- audit trail records [13-14](#)
- band OADM power statistics [9-18](#)
- channel OADM power statistics [9-16](#)
- conditions [8-12](#)
- IS-IS RIB [13-9](#)
- login node groups [2-27](#)
- MAC address [3-14](#)
- multiplexer and demultiplexer card optical power statistics [9-13](#)
- MXP\_MR\_2.5G and MXPP\_MR\_2.5G card payload PM parameters [9-27, 9-29, 9-30, 9-32](#)
- near-end PM counts [9-4, 9-5](#)
- OCHNCs and OCHCCs [7-32](#)
- OCHNCs on a span [7-37](#)
- OCH trail [7-32, 7-33](#)
- optical amplifier power statistics [9-12](#)
- OSCM and OSC-CSM card PM counts [9-10](#)
- OSI information [13-9](#)
- OTN PM parameters [9-25](#)
- part numbers in CTC [A-14](#)
- ROADM node power equalization [10-5](#)
- service states [A-14](#)

timing report [13-19](#)

transponder and muxponder optics parameters [9-22](#)

transponder and muxponder payload parameters [9-23](#)

virtual link table (OSPF) [3-22](#)

VOA

- changing for 32WSS and 32WSS-L cards [11-51](#)
- changing for multiplexer and demultiplexer cards [11-44](#)
- changing for OSCM and OSC-CSM cards [11-7](#)
- running ANS [3-82](#)

voltage, measuring [1-84](#)

voltmeter

- verifying office battery and ground [1-39](#)
- verifying the office ground and power [1-84](#)
- verifying the shelf and ground power wiring [1-84](#)
- verifying the shelf for -48 VDC [1-39](#)

---

## W

warnings

- definition of [1-l to 1-liv](#)
- finding information about [1-lv](#)

wires. *See* cables

wire-wrap panel, external [1-57](#)

---

## X

XFPs. *See* SFPs

XML file [3-38](#)

---

## Y

Y-cable modules

- installing fiber [3-75](#)
- installing modules [1-70, 1-71](#)
- installing the tray [1-67](#)

Y-cable protection

- See also* FlexLayer
- See also* Y-cable modules

definition [5-15](#)  
deleting a protection group [10-36](#)  
modifying a protection group [10-35](#)  
performing a protection switch test [6-15](#)  
protecting a single client signal [3-76](#)  
protecting two client signals [3-76](#)  
protection switches [10-37](#)  
provisioning a protection group [5-14](#)

---

## Z

zooming [A-7](#)