



Turn Up a Node

This chapter explains how to provision a single Cisco ONS 15454 dense wavelength division multiplexing (DWDM) node and turn it up for service, including assigning the node name, date, and time; provisioning timing references; provisioning network attributes such as IP address and default router; setting up users and user security; installing cards; and creating DWDM connections.



Note

Procedures in this chapter require that you have a network plan calculated for your DWDM network with Cisco MetroPlanner, Release 7.0. Cisco MetroPlanner is a DWDM planning tool that is available from your Cisco account representative. Cisco MetroPlanner prepares a shelf plan for each network node and calculates the power and attenuation levels for the DWDM cards installed in the node. For information about Cisco MetroPlanner, contact your Cisco account representative. For instructions on using Cisco MetroPlanner, refer to the *Cisco MetroPlanner DWDM Operations Guide, Release 7.0*.



Note

Unless otherwise specified, in this document “ONS 15454” refers to both ANSI (ONS 15454) and ETSI (ONS 15454 SDH) shelf assemblies.



Note

CTC views referenced in these procedures depend on the ONS 15454 mode. In single-shelf mode, the views are network, node, and card. In multishelf mode, the views are network, multishelf, shelf, and card. For more information about CTC views, refer to [Appendix A, “CTC Information and Shortcuts.”](#)

Before You Begin

This section lists the non-trouble procedures (NTPs) needed to turn up a DWDM node. Turn to an NTP for applicable detail-level procedures (DLPs), known as tasks.

1. [NTP-G139 Verify Cisco MetroPlanner Reports and Files, page 3-3](#)—Complete this procedure first.
2. [NTP-G22 Verify Common Card Installation, page 3-4](#)—Complete this procedure next.
3. [NTP-G144 Provision a Multishelf Node, page 3-6](#)—Complete this procedure as needed.
4. [NTP-G23 Create Users and Assign Security, page 3-7](#)—Complete this procedure to create Cisco Transport Controller (CTC) users and assign their security levels.
5. [NTP-G24 Set Up Name, Date, Time, and Contact Information, page 3-10](#)—Continue with this procedure to set the node name, date, time, location, and contact information.

6. [NTP-G25 Set Battery Power Monitor Thresholds, page 3-12](#)—Continue with this procedure to set the node battery power thresholds.
7. [NTP-G26 Set Up CTC Network Access, page 3-13](#)—Continue with this procedure to provision the IP address, default router, subnet mask, and other network configuration settings.
8. [NTP-G341 Set Up Secure Access to the ONS 15454 TL1, page 3-24](#)—Continue with this procedure to enable secure access to TL1.
9. [NTP-G27 Set Up the ONS 15454 for Firewall Access, page 3-25](#)—Continue with this procedure if the ONS 15454 will be accessed behind firewalls.
10. [NTP-G132 Provision OSI, page 3-28](#)—Continue with this procedure if the ONS 15454 will be installed in networks with third-party, Open Systems Interconnection (OSI)-based network elements (NEs).
11. [NTP-G28 Set Up SNMP, page 3-38](#)—Complete this procedure if Simple Network Management Protocol (SNMP) will be used for network monitoring.
12. [NTP-G143 Import the Cisco MetroPlanner NE Update Configuration File, page 3-40](#)—Complete this procedure to preprovision the ONS 15454 slots and install the card and automatic node setup (ANS) parameters.
13. [NTP-G30 Install the DWDM Cards, page 3-47](#)—Complete this procedure to install the DWDM cards, including the OSCM, OSC-CSM, 32WSS, 32WSS-L, OPT-BST, OPT-BST-E, OPT-BST-L, OPT-AMP-L, OPT-PRE, 32MUX-O, 32DMX-O, 32DMX, 32DMX-L, 4MD-xx.x, AD-1C-xx.x, AD-2C-xx.x, AD-4C-xx.x, AD-1B-xx.x, AD-4B-xx.x, and MMU.
14. [NTP-G31 Install the DWDM Dispersion Compensating Units, page 3-51](#)—Complete this procedure, as needed, to install a dispersion compensating unit (DCU).
15. [NTP-G32 Install the Transponder and Muxponder Cards, page 3-52](#)—Complete this procedure, as needed, to install transponder (TXP) and muxponder (MXP) cards.
16. [NTP-G123 Install the Filler Cards, page 3-57](#)—Complete this procedure, as needed, to install ONS 15454 filler cards.
17. [NTP-G34 Install Fiber-Optic Cables on DWDM Cards and DCUs, page 3-58](#)—Complete this procedure, as needed, to install the fiber-optic cables on the DWDM cards.
18. [NTP-G140 Install Fiber-Optic Cables Between Terminal, Hub, or ROADM Node DWDM Cards and TXP/MXP Cards, page 3-64](#)—Complete this procedures, as needed, to connect TXP and MXP cards to DWDM cards in a terminal, hub, or ROADM node through the patch panel.
19. [NTP-G191 Install Fiber-Optic Cables on Passthrough ROADM Nodes, page 3-75](#)—Complete this procedures, as needed, to route fiber-optic cables from a 32WSS card in a ROADM node in one shelf to the corresponding 32WSS card in a ROADM node in another shelf. The purpose of this routing is to connect East and West intershelf ROADMs in a passthrough configuration.
20. [NTP-G141 Install Fiber-Optic Cables for Y-Cable Protection Modules, page 3-77](#)—Complete this procedure, as needed, to connect fiber-optic cables to Y-cable modules from client TXP, MXP, and ITU cards.
21. [NTP-G152 Create and Verify Internal Patchcords, page 3-82](#)—Complete this procedure to calculate the DWDM cable connections.
22. [NTP-G37 Run Automatic Node Setup, page 3-86](#)—Complete this procedure next.
23. [NTP-G38 Provision OSC Terminations, page 3-87](#)—Complete this procedure next.
24. [NTP-G39 Verify OSCM Transmit Power, page 3-89](#)—Complete this procedure next.
25. [NTP-G163 Upgrade Nodes in Single-Shelf Mode to Multishelf Mode, page 3-92](#)—Complete this procedure as needed.

NTP-G139 Verify Cisco MetroPlanner Reports and Files

Purpose	This procedure verifies that you have the Cisco MetroPlanner reports and files needed to turn up the node.
Tools/Equipment	None
Prerequisite Procedures	Chapter 1, “Install the Shelf and Common Control Cards”
Required/As Needed	Required
Onsite/Remote	Onsite
Security Level	Retrieve or higher

Step 1 Verify that you have the Cisco MetroPlanner reports and files shown in [Table 3-1](#) for the node that you will provision. The reports and files can be provided in one of the following ways:

- If you have Cisco MetroPlanner, verify that you have the electronic network design plan from which you can generate the reports in Cisco MetroPlanner. For information about generating the reports, refer to the *Cisco MetroPlanner DWDM Operations Guide*.
- If you do not have Cisco MetroPlanner, you must have printouts of all reports listed in [Table 3-1](#) except the Assisted Configuration Setup file. Assisted Configuration Setup is an electronic file that will be imported into CTC. You must be able to access it from the CTC computer used to provision the node.

Table 3-1 Cisco MetroPlanner Node Setup Information and Files

Source	Format	Description
Shelf layout	JPG file	Cisco MetroPlanner provides a shelf layout (Figure 3-1) showing the cards that should be installed in each ONS 15454 slot. Cisco MetroPlanner can export this as a JPG file with a user-defined name.
Installation Parameters	Table	Provides the target reference values for the variable optical attenuators (VOAs), output power, optical thresholds, and amplifier configuration parameters.
Internal Connections	Table	Identifies the patchcords that must be installed within the shelf.
NE Update Configuration file	XML file	The Cisco MetroPlanner NE Update configure file is an electronic file with an XML extension and a name assigned by the network designer for the network you are provisioning. The file is imported into CTC where it preprovisions the shelf, configures the OPT-AMP-L card, if present, and configures the Automatic Node Setup (ANS) parameters based on the network calculated by Cisco MetroPlanner.
Traffic Matrix	Table	Shows the traffic flow within the node. During node turn-up, this report is used to identify the location of Y-cable protection groups.
Cable list	Table or list	A list of cables needed to provision the node. The list can be derived from the Internal Connections Report or from the Bill of Materials report prepared by Cisco MetroPlanner.

Figure 3-1 Cisco MetroPlanner Shelf Layout

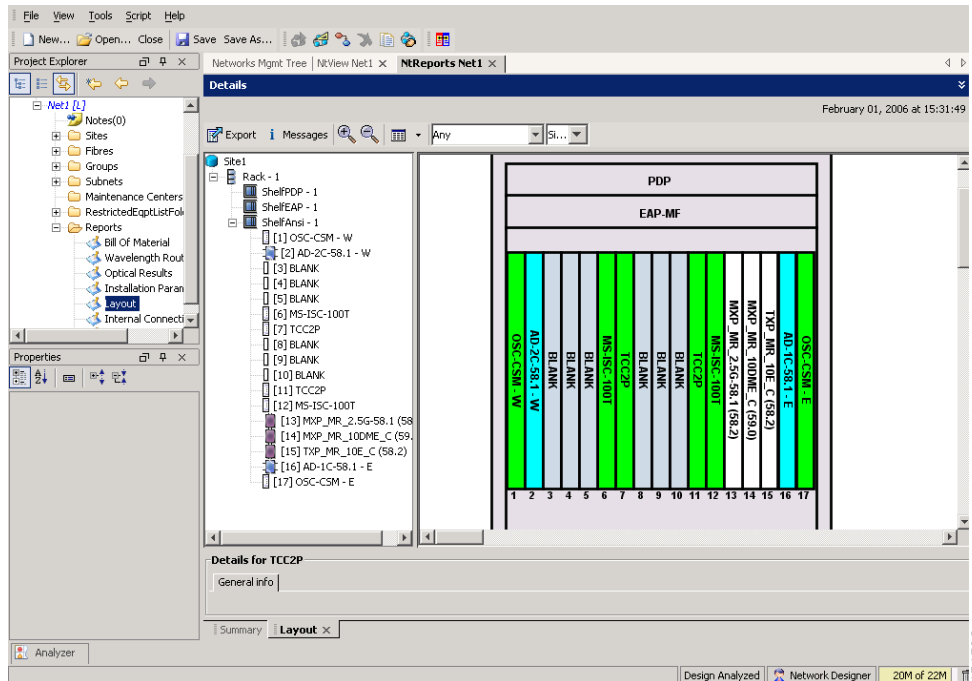

If you do not have all the reports and files listed in [Table 3-1](#), do not continue. See your site or network planner for the required information and files.

- Step 2** Print [Table 3-1](#) for reference. You will need information from the reports during node turn-up.
Stop. You have completed this procedure.

NTP-G22 Verify Common Card Installation

Purpose	This procedure verifies that the ONS 15454 node has two TCC2 or TCC2P cards installed. It also verifies the installation of the AIC-I and MS-ISC-100T cards, if they are installed.
Tools/Equipment	None
Prerequisite Procedures	Chapter 1, “Install the Shelf and Common Control Cards”
Required/As Needed	Required
Onsite/Remote	Onsite
Security Level	Retrieve or higher

- Step 1** Verify that two TCC2 or two TCC2P cards are installed in Slots 7 and 11.
- Step 2** Verify that the FAIL LED is off and the green ACT (active) LED is illuminated on one TCC2 or TCC2P card and the amber STBY (standby) LED is illuminated on the second TCC2 or TCC2P card.

**Note**

If the TCC2/TCC2P cards are not installed, or if their LEDs are not operating as described, do not continue. Repeat the “[DLP-G33 Install the TCC2 or TCC2P Card](#)” task on page 1-75 or refer to the *Cisco ONS 15454 DWDM Troubleshooting Guide* to resolve installation problems before proceeding to [Step 3](#).

Step 3 If the AIC-I card is installed, verify that it is installed in Slot 9 and its ACT (active) LED displays a solid green light.

**Note**

If the AIC-I card is not installed and the card is required by the Cisco MetroPlanner shelf layout, or if it is installed and its LEDs are not operating as described, do not continue. Repeat the “[DLP-G34 Install the AIC-I Card](#)” task on page 1-78 or refer to the *Cisco ONS 15454 DWDM Troubleshooting Guide* to resolve installation problems before proceeding to [Step 4](#).

Step 4 Verify that the software release shown on the LCD matches the software release required for your network. On the LCD, the software release is shown under the platform (Sonet or SDH) and date/temperature. If the release does not match, perform one of the following procedures:

- Perform a software upgrade using a Cisco ONS 15454 software CD or Cisco ONS 15454 SDH software CD. Refer to the release-specific software upgrade document.
- Replace the TCC2/TCC2P cards with cards containing the correct release.

Step 5 If the node will be configured as a multishelf node, verify that redundant MS-ISC-100T cards are installed (Slots 6 and 12 are recommended) and that the green ACT (active) LED is illuminated on both cards.

**Note**

If the MS-ISC-100T card is not installed and the card is required by the Cisco MetroPlanner shelf layout, or if the card’s LEDs are not operating as described, do not continue. Repeat the “[DLP-G309 Install the MS-ISC-100T Card](#)” task on page 1-79 or refer to the *Cisco ONS 15454 DWDM Troubleshooting Guide* to resolve installation problems before proceeding to the next procedure.

Stop. You have completed this procedure.

NTP-G144 Provision a Multishelf Node

Purpose	This procedure provisions a multishelf node from CTC. A multishelf node consists of a control node and subtending shelves that are configured to operate as a single node.
Tools/Equipment	None
Prerequisite Procedures	NTP-G22 Verify Common Card Installation, page 3-4 NTP-G145 Connect a Multishelf Node and Subtending Shelves to an MS-ISC-100T Card, page 1-81 or NTP-G158 Connect a Multishelf Node and Subtending Shelves to a Catalyst 2950, page 1-83
Required/As Needed	As needed
Onsite/Remote	Onsite or remote
Security Level	Superuser



Caution

An optical shelf in a multishelf configuration must be provisioned as the node controller shelf and not a subtending shelf, otherwise traffic will be dropped. If no slots are available on an optical shelf to install the MS-ISC-100T cards needed for a node controller shelf, install and configure the Cisco Catalyst 2950. See the “[NTP-G158 Connect a Multishelf Node and Subtending Shelves to a Catalyst 2950](#)” procedure on page 1-83.

-
- Step 1** Complete the “[DLP-G46 Log into CTC](#)” task on page 2-27 at the node that you want to configure as a multishelf node.
- Step 2** If you want to configure a shelf as the node controller, continue with [Step 3](#). If you want to configure a shelf as a subtending shelf, continue with [Step 4](#).
- Step 3** To set up the login node as the node controller, complete the following steps:
- In node view (single-node mode) or multishelf view (multishelf mode), click the **Provisioning > General > Multishelf Config** tabs.
 - Click **Enable as Node Controller**.
 - From the LAN Config drop-down list, complete one of the following:
 - Choose **Ethernet Switch** if MS-ISC-100T cards or the Catalyst 2950 switches are already installed and configured.
 - Choose **Stand-Alone** if MS-ISC-100T cards are not installed yet but will be included in the final layout. This option will allow a safe migration of the TCC2/TCC2P card database when the multishelf configuration is complete.
 - Click **Apply**.
 - In the confirmation dialog box, click **Yes** to allow the node to reboot. The CTC view changes to network view and the node icon changes to gray. Wait for the reboot to finish. (This might take several minutes.)
 - After the node reboots, double-click the node. The multishelf view appears.



Note The shelf ID of the node controller is automatically assigned as 1.

- Step 4** To add a node equipped with transponder and muxponder cards as a subtending shelf in the multishelf configuration, complete the following steps:
- a. In multishelf view, right-click in the white space in the rack and choose **Add Shelf**.
 - b. In the Shelf ID Selection dialog box, choose a shelf ID (from 2 to 8) from the drop-down list.
 - c. Click **OK**. The shelf appears in the multishelf view.
 - d. Disconnect the cross-over (CAT-5) LAN cable from the RJ-45 LAN (TCP/IP) port of the subtending shelf TCC2/TCC2P card in Slot 11.
 - e. Connect your Windows PC or Solaris workstation NIC to the RJ-45 LAN (TCP/IP) port on the TCC2/TCC2P card in slot 11.
 - f. Complete the “[DLP-G46 Log into CTC](#)” task on page 2-27 at the subtending shelf.
 - g. Click the **Provisioning > General > Multishelf Config** tabs.
 - h. Click **Enable as Subtended Shelf**.
 - i. From the Shelf ID drop-down list, choose the shelf ID that you created in Step b.
 - j. Click **Apply**.
 - k. In the confirmation dialog box, click **Yes** to reboot the shelf. The CTC view changes to network view and the node icon changes to gray. Wait for the reboot to finish. (This might take several minutes.)
 - l. Disconnect your Windows PC or Solaris workstation NIC from the RJ-45 LAN (TCP/IP) port of the subtending shelf TCC2/TCC2P card in Slot 11.
 - m. Reconnect the cross-over (CAT-5) LAN cable (disconnected in Step d) to the RJ-45 LAN (TCP/IP) port of the subtending shelf TCC2/TCC2P card in Slot 11.
 - n. Repeat Steps a through m to set up additional subtending shelves.
- Stop. You have completed this procedure.**

NTP-G23 Create Users and Assign Security

Purpose	This procedure creates ONS 15454 users and assigns their security levels.
Tools/Equipment	None
Prerequisite Procedures	NTP-G22 Verify Common Card Installation, page 3-4
Required/As Needed	As needed
Onsite/Remote	Onsite or remote
Security Level	Superuser

- Step 1** Complete the “[DLP-G46 Log into CTC](#)” task on page 2-27 at the node where you need to create users. If you are already logged in, continue with Step 2.



Note You must log in as a Superuser to create additional users. The CISCO15 user provided with each ONS 15454 can be used to set up other ONS 15454 users. You can add up to 500 users to one ONS 15454.

- Step 2** Complete the “[DLP-G54 Create a New User on a Single Node](#)” task on page 3-8 or the “[DLP-G55 Create a New User on Multiple Nodes](#)” task on page 3-9 as needed.



Note You must add the same user name and password to each node a user will access.

- Step 3** If you want to modify the security policy settings, including password aging and idle user timeout policies, complete the “[NTP-G88 Modify Users and Change Security](#)” procedure on page 10-49.

Stop. You have completed this procedure.

DLP-G54 Create a New User on a Single Node

Purpose	This task creates a new user for one ONS 15454.
Tools/Equipment	None
Prerequisite Procedures	DLP-G46 Log into CTC , page 2-27
Required/As Needed	As needed
Onsite/Remote	Onsite or remote
Security Level	Superuser

- Step 1** In node view (single-shelf mode) or multishelf view (multishelf mode), click the **Provisioning > Security > Users** tabs.

- Step 2** In the Users window, click **Create**.

- Step 3** In the Create User dialog box, enter the following:

- **Name**—Type the user name. The name must be a minimum of six and a maximum of 20 alphanumeric (a-z, A-Z, 0-9) characters. For TL1 compatibility, the user name must be 6 to 10 characters.
- **Password**—Type the user password. The password must be a minimum of six and a maximum of 20 alphanumeric (a-z, A-Z, 0-9) and special (+, #, %) characters, where at least two characters are non alphabetic and at least one character is a special character. For TL1 compatibility, the password must be 6 to 10 characters.



Note The password must not contain the user name.

- **Confirm Password**—Type the password again to confirm it.
- **Security Level**—Choose a security level for the user: RETRIEVE, MAINTENANCE, PROVISIONING, or SUPERUSER.



Note Each security level has a different idle time. The idle time is the length of time that CTC can remain idle before the password must be reentered. The defaults are: Retrieve user = unlimited, Maintenance user = 60 minutes, Provisioning user = 30 minutes, and Superuser = 15 minutes. To change the idle times, see the “[NTP-G88 Modify Users and Change Security](#)” procedure on page 10-49.

- Step 4** Click **OK**.
- Step 5** Return to your originating procedure (NTP).

DLP-G55 Create a New User on Multiple Nodes

Purpose	This task adds a new user to multiple ONS 15454 nodes.
Tools/Equipment	None
Prerequisite Procedures	DLP-G46 Log into CTC, page 2-27
Required/As Needed	As needed
Onsite/Remote	Onsite or remote
Security Level	Superuser



Note All nodes where you want to add users must be accessible in network view.

- Step 1** From the View menu, choose **Go to Network View**.
- Step 2** Click the **Provisioning > Security > Users** tabs.
- Step 3** In the Users window, click **Create**.
- Step 4** In the Create User dialog box, enter the following:
- **Name**—Type the user name. The name must be a minimum of six and a maximum of 20 alphanumeric (a-z, A-Z, 0-9) characters. For TL1 compatibility, the user name must be 6 to 10 characters.
 - **Password**—Type the user password. The password must be a minimum of six and a maximum of 20 alphanumeric (a-z, A-Z, 0-9) and special (+, #, %) characters, where at least two characters are non alphabetic and at least one character is a special character. For TL1 compatibility, the password must be 6 to 10 characters. The password must not contain the user name.
 - **Confirm Password**—Type the password again to confirm it.
 - **Security Level**—Choose a security level for the user: RETRIEVE, MAINTENANCE, PROVISIONING, or SUPERUSER.



Note Each security level has a different idle time. The idle time is the length of time that CTC can remain idle before it locks up and the password must be reentered. The defaults are: Retrieve user = unlimited, Maintenance user = 60 minutes, Provisioning user = 30 minutes, and Superuser = 15 minutes. To change the idle times, refer to the [“NTP-G88 Modify Users and Change Security” procedure on page 10-49](#).

- Step 5** In the Select Applicable Nodes area, deselect any nodes where you do not want to add the user (all network nodes are selected by default).
- Step 6** Click **OK**.
- Step 7** In the User Creation Results dialog box, verify that the user was added to all the nodes chosen in [Step 5](#). If not, click **OK** and repeat Steps [2](#) through [6](#). If the user was added to all nodes, click **OK** and continue with the next step.

Step 8 Return to your originating procedure (NTP).

NTP-G24 Set Up Name, Date, Time, and Contact Information

Purpose	This procedure provisions identification information for the node, including the node name, a contact name and phone number, the location of the node, and the date, time, and time zone.
Tools/Equipment	None
Prerequisite Procedures	NTP-G22 Verify Common Card Installation, page 3-4
Required/As Needed	As needed
Onsite/Remote	Onsite or remote
Security Level	Provisioning or higher

- Step 1** Complete the [“DLP-G46 Log into CTC” task on page 2-27](#) for the node you will turn up. If you are already logged in, continue with Step 2.
- Step 2** In node view (single-shelf mode) or multishelf view (multishelf mode), click the **Provisioning > General > General** tabs.
- Step 3** In the Node Name field, type a name for the node. For TL1 compliance, names must begin with an alpha character and have no more than 20 alphanumeric (a-z, A-Z, 0-9) characters.



Note To avoid errors when you import the Cisco MetroPlanner configuration file in the [“NTP-G143 Import the Cisco MetroPlanner NE Update Configuration File” task on page 3-40](#), the CTC node name and the Cisco MetroPlanner site name should be the same or at least easy to identify.

- Step 4** (Optional) In the Contact field, type the name of the node contact person and the phone number, up to 255 characters.
- Step 5** (Optional) In the Latitude field, enter the node latitude: N (north) or S (south), degrees, and minutes.
- Step 6** (Optional) In the Longitude field, enter the node longitude: E (east) or W (west), degrees, and minutes. CTC uses the latitude and longitude to position ONS 15454 icons on the network view map. To convert a coordinate in degrees to degrees and minutes, multiply the number after the decimal by 60. For example, the latitude 38.250739 converts to 38 degrees, 15 minutes ($0.250739 \times 60 = 15.0443$, rounded to the nearest whole number).
- Step 7** (Optional) In the Description field, type a description of the node. The description can be a maximum of 255 characters.
- Step 8** (Optional) Check the Use NTP/SNTP Server check box. When checked, CTC uses a Network Time Protocol (NTP) or Simple Network Time Protocol (SNTP) server to set the date and time of the node. Using an NTP or SNTP server ensures that all ONS 15454 network nodes use the same date and time reference. The server synchronizes the node’s time after power outages or software upgrades.
- a. If you check the Use NTP/SNTP Server check box, type the IP address of one of the following:
 - An NTP/SNTP server connected to the ONS 15454
 - Another ONS 15454 with NTP/SNTP enabled that is connected to the ONS 15454

**Note**

If you plan to check gateway network element (GNE) for the ONS 15454 SOCKS proxy server (see [“DLP-G56 Provision IP Settings” task on page 3-14](#)), external ONS 15454 nodes must reference the gateway ONS 15454 for NTP/SNTP timing. For more information about the ONS 15454 gateway settings, refer to the “Management Network Connectivity” chapter in the *Cisco ONS 15454 DWDM Reference Manual*.

**Caution**

If you reference another ONS 15454 for the NTP/SNTP server, make sure that the second ONS 15454 references an NTP/SNTP server and not the first ONS 15454 (that is, do not create an NTP/SNTP timing loop by having two ONS 15454 nodes reference each other).

- b. If you did not check Use SNTP/NTP Server, complete the Date and Time fields. The ONS 15454 will use these fields for alarm dates and times. By default, CTC displays all alarms in the CTC computer time zone for consistency. To change the display to the node time zone, complete the [“DLP-G118 Display Alarms and Conditions Using Time Zone” task on page 9-12](#).
 - Date—Type the current date in the format m/d/yyyy, for example, September 24, 2002 is 9/24/2002.
 - Time—Type the current time in the format hh:mm:ss, for example, 11:24:58. The ONS 15454 uses a 24-hour clock, so 10:00 PM is entered as 22:00:00.

Step 9 Click the Time Zone field and choose a city within your time zone from the drop-down list. The list displays the 80 World Time Zones from –11 through 0 (GMT) to +14. Continental United States time zones are GMT-05:00 (Eastern), GMT-06:00 (Central), GMT-07:00 (Mountain), and GMT-08:00 (Pacific).

Step 10 Click the Use Daylight Savings Time check box if the time zone that you chose uses Daylight Savings Time.

**Note**

The Insert AIS-V on STS-1 SD-P and SD-P BER field are not used in DWDM networks.

Step 11 Click **Apply**.

Step 12 In the confirmation dialog box, click **Yes**.

Step 13 Review the node information. If you need to make corrections, repeat Steps 3 through 12 to enter the corrections. If the information is correct, continue with the [“NTP-G25 Set Battery Power Monitor Thresholds” procedure on page 3-12](#).

Stop. You have completed this procedure.

NTP-G25 Set Battery Power Monitor Thresholds

Purpose	This procedure provisions extreme high, extreme low, and low input battery power thresholds within a –48 VDC environment.
Tools/Equipment	None
Prerequisite Procedures	NTP-G22 Verify Common Card Installation, page 3-4
Required/As Needed	Required
Onsite/Remote	Onsite or remote
Security Level	Provisioning or higher



Caution

The default battery power thresholds are normally not changed. Threshold changes should only be performed at the direction of your site administrator.



Note

When the thresholds are crossed, the TCC2/TCC2P card generates warning alarms in CTC. For ONS 15454 power specifications, see the “Hardware Specifications” appendix in the *Cisco ONS 15454 DWDM Reference Manual*.

- Step 1** Complete the “[DLP-G46 Log into CTC](#)” task on page 2-27 for the node you will set up. If you are already logged in, continue with Step 2.
- Step 2** In node view (single-shelf mode) or shelf view (multishelf mode), click the **Provisioning > General > Power Monitor** tabs.



Note

In multishelf mode, power monitor thresholds must be provisioned for each shelf within the multishelf including the node controller and all subtending shelves.

- Step 3** To change the extreme low battery voltage threshold in 0.5 VDC increments, choose a voltage from the ELWBATVGVdc drop-down list.
- Step 4** To change the low battery voltage threshold in 0.5 VDC increments, choose a voltage from the LWBATVGVdc drop-down list.
- Step 5** To change the high battery voltage threshold in 0.5 VDC increments, choose a voltage from the HIBATVGVdc drop-down list.
- Step 6** To change the extreme high battery voltage threshold in 0.5 VDC increments, choose a voltage from the EHIBATVGVdc drop-down list.
- Step 7** Click **Apply**.

Stop. You have completed this procedure.

NTP-G26 Set Up CTC Network Access

Purpose	This procedure provisions network access for a node, including its subnet mask, default router, Dynamic Host Configuration Protocol (DHCP) server, Internet Inter-Orb Protocol (IIOP) listener port, gateway settings, static routes, Open Shortest Path First (OSPF) protocol, and Routing Information Protocol (RIP).
Tools/Equipment	None
Prerequisite Procedures	NTP-G22 Verify Common Card Installation, page 3-4
Required/As Needed	Required
Onsite/Remote	Onsite or remote
Security Level	Superuser

-
- Step 1** Complete the [“DLP-G46 Log into CTC” task on page 2-27](#). If you are already logged in, continue with [Step 2](#).
- Step 2** Complete the [“DLP-G56 Provision IP Settings” task on page 3-14](#) to provision the ONS 15454 IP address, subnet mask, default router, DHCP server, IIOP listener port, and SOCKS proxy server settings.



Tip If you cannot log into the node, you can change its IP address, default router, and network mask by using the LCD on the ONS 15454 fan-tray assembly (unless LCD provisioning is suppressed). See the [“DLP-G57 Set the IP Address, Default Router, and Network Mask Using the LCD” task on page 3-16](#) for instructions. However, you cannot use the LCD to provision any other network settings.

- Step 3** If TCC2P cards are installed and you want to turn on the ONS 15454 secure mode, which allows two IP addresses to be provisioned for the node, complete the [“DLP-G264 Enable Node Security Mode” task on page 3-18](#). Secure mode is not available if TCC2 cards are installed.
- Step 4** If static routes are needed, complete the [“DLP-G58 Create a Static Route” task on page 3-20](#). For more information about static routes, refer to the “Management Network Connectivity” chapter in the *Cisco ONS 15454 DWDM Reference Manual*.
- Step 5** If the ONS 15454 is connected to a LAN or WAN that uses OSPF and you want to share routing information between the LAN or WAN and the ONS network, complete the [“DLP-G59 Set Up or Change Open Shortest Path First Protocol” task on page 3-21](#).
- Step 6** If the ONS 15454 is connected to a LAN or WAN that uses RIP, complete the [“DLP-G60 Set Up or Change Routing Information Protocol” task on page 3-23](#).

Stop. You have completed this procedure.

DLP-G56 Provision IP Settings

Purpose	This task provisions IP settings, which includes the IP address, default router, DHCP access, firewall access, and SOCKS proxy server settings for an ONS 15454 node.
Tools/Equipment	None
Prerequisite Procedures	DLP-G46 Log into CTC, page 2-27
Required/As Needed	Required
Onsite/Remote	Onsite or remote
Security Level	Superuser



Caution

All network changes should be approved by your network (or LAN) administrator.

Step 1 In node view (single-shelf mode) or multishelf view (multishelf mode), click the **Provisioning > Network > General** tabs.

Step 2 Complete the following information in the fields listed:

- IP Address—Type the IP address assigned to the ONS 15454 node.



Note

If TCC2P cards are installed, dual IP addressing via secure mode is available. When secure mode is off (sometimes called repeater mode), the IP address entered in the IP Address field applies to the ONS 15454 backplane LAN port and the TCC2P TCP/IP (LAN) port. When secure mode is on, the IP Address field shows the address assigned to the TCC2P TCP/IP (LAN) port and the superuser can enable or disable display of the backplane IP address. See [“DLP-G264 Enable Node Security Mode”](#) as needed. Refer to the “Management Network Connectivity” chapter in the *Cisco ONS 15454 DWDM Reference Manual* for more information about secure mode.

- Net/Subnet Mask Length—Type the subnet mask length (decimal number representing the subnet mask length in bits) or click the arrows to adjust the subnet mask length. The subnet mask length is the same for all ONS 15454 nodes in the same subnet.
- MAC Address—(Display only) Displays the ONS 15454 IEEE 802 MAC address.



Note

In secure mode, the front and back TCP/IP (LAN) ports are assigned different MAC addresses, and the backplane information can be hidden or revealed by a Superuser.

- Default Router—If the ONS 15454 is connected to a LAN, enter the IP address of the default router. The default router forwards packets to network devices that the ONS 15454 cannot directly access. This field is ignored if any of the following are true:
 - The ONS 15454 is not connected to a LAN.
 - SOCKS proxy server is enabled and the ONS 15454 is provisioned as an end network element (ENE).
 - OSPF (Open Shortest Path First) is enabled on both the ONS 15454 (the OSPF on LAN check box on the Provisioning > Network > OSPF tab) and the LAN where the ONS 15454 is connected.

- LCD IP Setting—Choose one of the following:
 - **Allow Configuration**—Displays the node IP address on the LCD and allows users to change the IP settings using the LCD. This option enables the “[DLP-G57 Set the IP Address, Default Router, and Network Mask Using the LCD](#)” task on page 3-16.
 - **Display Only**—Displays the node IP address on the LCD but does not allow users to change the IP settings using the LCD.
 - **Suppress Display**—Suppresses the node IP address display on the LCD.
- Suppress CTC IP Display—Check this check box if you want to prevent the node IP address from appearing in CTC to users with Provisioning, Maintenance, or Retrieve security levels. (The IP address suppression is not applied to users with Superuser security level.)



Note IP address suppression is not applied to users with Superuser security level. However, in secure mode the backplane IP address visibility can be restricted to only a locally connected Superuser viewing the routing table. In this case, the backplane IP address is not revealed to any user at any other NE on the routing table or in autonomous messages (such as the TL1 REPT^DBCHG command, alarms, and PM reporting).

- Forward DHCP Request To—Check this check box to enable DHCP. Also, enter the DHCP server IP address in the Request To field. Unchecked is the default. If you will enable any of the gateway settings to implement the ONS 15454 SOCKS proxy server features, leave this field blank.



Note If you enable DHCP, computers connected to an ONS 15454 node can obtain temporary IP addresses from an external DHCP server. The ONS 15454 only forwards DHCP requests; it does not act as a DHCP server.

- Gateway Settings—Provisions the ONS 15454 SOCKS proxy server features. (SOCKS is a standard proxy protocol for IP-based applications.) Do not change these options until you review Scenario 7 in the “Management Network Connectivity” chapter of the *Cisco ONS 15454 DWDM Reference Manual*. In SOCKS proxy server networks, the ONS 15454 is either an ENE, a GNE, or a proxy-only server. Provisioning must be consistent for each NE type.
- Enable SOCKS proxy server on port—If checked, the ONS 15454 serves as a proxy for connections between CTC clients and ONS 15454 nodes that are connected by data communications channels (DCCs) to the proxy ONS 15454. The CTC client establishes connections to DCC-connected nodes through the proxy node. The CTC client does not require IP connectivity to the DCC-connected nodes; it only requires IP connectivity to the proxy ONS 15454. If the Enable SOCKS proxy server on port check box is unchecked, the node does not proxy for any CTC clients. When this box is checked, you can provision one of the following options:
 - External Network Element (ENE)—Choose this option when the ONS 15454 is not connected to a LAN but has DCC connections to other ONS nodes. A CTC computer connected to the ENE through the TCC2/TCC2P card TCP/IP (craft) port can manage nodes that have DCC connections to the ENE. However, the CTC computer does not have direct IP connectivity to these nodes or to any LAN or WAN that those nodes might be connected to.
 - Gateway Network Element (GNE)—Choose this option when the ONS 15454 is connected to a LAN and has DCC connections to other nodes. A CTC computer connected to the LAN can manage all nodes that have DCC connections to the GNE, but the CTC computer does not have direct IP connectivity to them. The GNE option isolates the LAN from the DCC network so that IP traffic originating from the DCC-connected nodes and any CTC computers connected to them is prevented from reaching the LAN.

- SOCKS proxy only—Choose this option when the ONS 15454 is connected to a LAN and the LAN is separated from the node by a firewall. The SOCKS proxy only option is the same as the GNE option, except that the SOCKS proxy only option does not isolate the DCC network from the LAN.



Note If a node is provisioned in secure mode, it is automatically provisioned as a GNE with SOCKS proxy enabled. However, this provisioning can be overridden, and the secure node can be changed to an ENE. In secure mode, SOCKS cannot be disabled. For information about provisioning, including GNE and ENE status, see the “[DLP-G264 Enable Node Security Mode](#)” task on page 3-18.

Step 3 Click **Apply**.

Step 4 Click **Yes** in the confirmation dialog box.

Both TCC2/TCC2P cards reboot, one at a time if changes were made to the IP address, subnet mask, or gateway settings. During this time (approximately 5-6 minutes), the active and standby TCC2/TCC2P card LEDs will blink, turn on, and turn off at different intervals. Eventually, a “Lost node connection, switching to network view” message appears.

Step 5 Click **OK**. The network view appears. The node icon appears in gray, during which time you cannot access the node.

Step 6 Double-click the node icon when it becomes green.

Step 7 Return to your originating procedure (NTP).

DLP-G57 Set the IP Address, Default Router, and Network Mask Using the LCD

Purpose	This task changes the ONS 15454 IP address, default router, and network mask using the LCD on the fan-tray assembly. Use this task if you cannot log into CTC.
Tools/Equipment	None
Prerequisite Procedures	DLP-G33 Install the TCC2 or TCC2P Card , page 1-75
Required/As Needed	As needed
Onsite/Remote	Onsite
Security Level	None



Note You cannot perform this task if the LCD IP Display field on the node view Provisioning > Network tab is set to Display Only or Suppress Display. See the “[DLP-G56 Provision IP Settings](#)” task on page 3-14 to view or change the LCD IP Display field. If the node is locked in secure mode with the LCD display disabled, you will not be able to change this provisioning unless the lock is disabled by Cisco Technical Support. Refer to the “Management Network Connectivity” chapter in the *Cisco ONS 15454 DWDM Reference Manual* for more information about secure mode.



Note The LCD reverts to normal display mode after 5 seconds of button inactivity.

- Step 1** On the ONS 15454 front panel, repeatedly press the **Slot** button until SHELF on the first line of the LCD appears. You are in the Shelf menu.
- Step 2** Repeatedly press the **Port** button until the following information appears:
- To change the node IP address, Node Status=IpAddress (Figure 3-2)
 - To change the node network mask, Node Status=Net Mask
 - To change the default router IP address, Node Status=Default Rtr

Figure 3-2 Selecting the IP Address Option

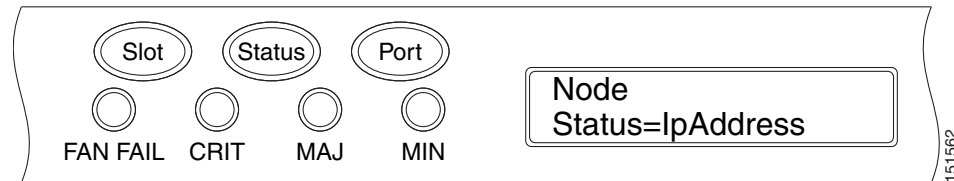

- Step 3** Press the **Status** button to display the node IP address (Figure 3-3), the node subnet mask length, or the default router IP address.

Figure 3-3 Changing the IP Address

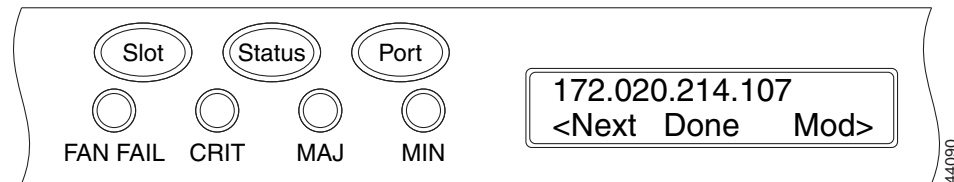

- Step 4** Push the **Slot** button to move to the digit of the IP address, subnet mask, or default router that you want to change. The selected digit flashes.



Tip The Slot, Status, and Port button positions correspond to the positions of the commands shown on the LCD. For example, in Figure 3-3, you press the Slot button to invoke the Next command and the Port button to invoke the Done command.

- Step 5** Press the **Port** button to cycle the IP address, subnet mask, or default router to the correct digit.
- Step 6** When the change is complete, press the **Status** button to return to the relative Node Status menu.
- Step 7** Repeatedly press the **Port** button until the Shelf Save Configuration option appears (Figure 3-4).

Figure 3-4 Selecting the Save Configuration Option

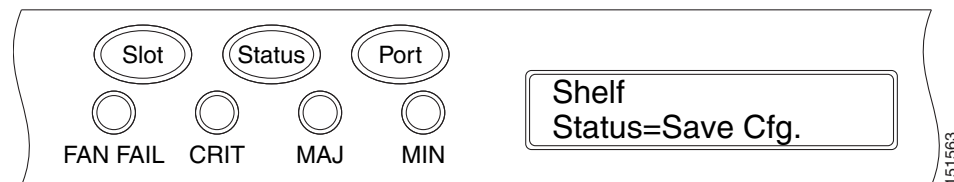

- Step 8** Press the **Status** button to choose the Save Configuration option.

A Save and REBOOT message appears (Figure 3-5).

Figure 3-5 Saving and Rebooting the TCC2/TCC2P

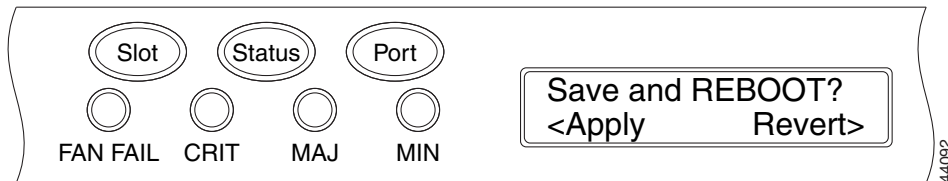

- Step 9** Press the **Slot** button to apply the new IP address, subnet mask, or default router configuration or press **Port** to cancel the configuration.



Note The IP address and default router must be on the same subnet. If not, you cannot apply the configuration.

- Step 10** Saving the new configuration causes the TCC2/TCC2P cards to reboot. During the reboot, a “TCC may Reset” message appears on the LCD. The LCD returns to the normal alternating display after both TCC2 cards or TCC2P cards finish rebooting.

- Step 11** Return to your originating procedure (NTP).

DLP-G264 Enable Node Security Mode

Purpose	This task enables the ONS 15454 security mode. When security mode is enabled, two IP addresses are assigned to the node. One address is assigned to the backplane LAN port and the other to the TCC2P RJ-45 TCP/IP (LAN) port. The TCC2 card does not support security mode.
Tools/Equipment	TCC2P cards must be installed. Do not install a mix of TCC2 and TCC2P cards.
Prerequisite Procedures	NTP-G103 Back Up the Database, page 13-2 DLP-G46 Log into CTC, page 2-27
Required/As Needed	As needed
Onsite/Remote	Onsite or remote
Security Level	Superuser



Caution

The IP address assigned to the TCC2P TCP/IP (LAN) port must reside on a different subnet from the backplane LAN port and the ONS 15454 default router. Verify that the new TCC2P IP address meets this requirement and is compatible with ONE 15454 network IP addresses.



Note

The node will reboot after you complete this task, causing a temporary disconnection between the CTC computer and the node.

Step 1 Click the **Provisioning > Security > Data Comm** tabs.



Note The security mode options are not available in CTC if TCC2 cards or a mix of TCC2 and TCC2P cards are installed.

Step 2 Click **Change Mode**.

Step 3 Review the information on the Change Secure Mode page, then click **Next**.

Step 4 On the TCC Ethernet Port page, enter the IP address and subnet mask for the TCC2P TCP/IP (LAN) port. The IP address cannot reside on the same subnet as the backplane LAN port or the ONS 15454 default router.

Step 5 Click **Next**.

Step 6 If needed, on the Backplane Ethernet Port page, modify the backplane IP address, subnet mask, and default router. (You normally do not modify these fields if no ONS 15454 network changes have occurred.)

Step 7 Click **Next**.

Step 8 On the SOCKS Proxy Server Settings page, choose one of the following options:

- **External Network Element (ENE)**—If selected, the CTC computer is only visible to the ONS 15454 where the CTC computer is connected. The CTC computer is not visible to the nodes connected to the data communications channel (DCC). In addition, firewall is enabled, which means that the node prevents IP traffic from being routed between the DCC and the LAN port.
- **Gateway Network Element (GNE)**—If selected, the CTC computer is visible to other DCC-connected nodes. The node prevents IP traffic from being routed between the DCC and the LAN port.



Note The SOCKS proxy server is automatically enabled when you enable secure mode.

Step 9 Click **Finish**.

Within the next 30 to 40 seconds, the TCC2P cards reboot. CTC switches to network view, and the CTC Alerts dialog box appears. In network view, the node changes to gray and a DISCONNECTED condition appears in the Alarms tab.

Step 10 In the CTC Alerts dialog box, click **Close**. Wait for the reboot to finish. (This might take several minutes.)

Step 11 After the DISCONNECTED condition clears, complete the following steps to suppress the backplane IP address from appearing in CTC and the LCD. If you do not want to suppress the backplane IP address display, continue with [Step 12](#).

- a. Display the node in node view (single-shelf mode) or multishelf view (multishelf mode).
- b. Click the **Provisioning > Security > Data Comm** tabs.
- c. In the LCD IP Setting field, choose **Suppress Display**. The IP address will not appear on the ONS 15454 LCD.
- d. Check the **Suppress CTC IP Address** check box. The IP address will not appear in the CTC information area or the Provisioning > Security > Data Comm tabs.
- e. Click **Apply**.



Note After you turn on secure mode, the TCC2P IP address becomes the node IP address.

Step 12 Return to your originating procedure (NTP).

DLP-G58 Create a Static Route

Purpose	This task creates a static route to establish CTC connectivity to a computer on another network. This task is performed when one of the following conditions exists: <ul style="list-style-type: none"> • CTC computers on one subnet need to connect to ONS 15454 nodes that are connected by a router to ONS 15454 nodes residing on another subnet. • OSPF is not enabled (OSPF Active on LAN check box on the Provisioning > Network > OSPF tab) and the External Network Element (ENE) gateway setting is not checked. • You need to enable multiple CTC sessions among ONS 15454 nodes residing on the same subnet and the External Network Element (ENE) gateway setting is not checked.
Tools/Equipment	None
Prerequisite Procedures	DLP-G46 Log into CTC, page 2-27
Required/As Needed	As needed.
Onsite/Remote	Onsite or remote
Security Level	Provisioning or higher

-
- Step 1** In node view (single-shelf mode) or multishelf view (multishelf mode), click the **Provisioning > Network** tabs.
- Step 2** Click the **Static Routing** tab. Click **Create**.
- Step 3** In the Create Static Route dialog box, enter the following:
- **Destination**—Enter the IP address of the computer running CTC. To limit access to one computer, enter the full IP address and a subnet mask of 255.255.255.255. To allow access to all computers on the 192.168.1.0 subnet, enter 192.168.1.0 and a subnet mask of 255.255.255.0. You can enter a destination of 0.0.0.0 to allow access to all CTC computers that connect to the router.
 - **Mask**—Enter a subnet mask. If the destination is a host route (that is, one CTC computer), enter a 32-bit subnet mask (255.255.255.255). If the destination is a subnet, adjust the subnet mask accordingly, for example, 255.255.255.0. If the destination is 0.0.0.0, CTC automatically enters a subnet mask of 0.0.0.0 to provide access to all CTC computers. You cannot change this value.
 - **Next Hop**—Enter the IP address of the router port or the node IP address if the CTC computer is connected to the node directly.
 - **Cost**—Enter the number of hops between the ONS 15454 and the computer.
- Step 4** Click **OK**. Verify that the static route appears in the Static Route window.



Note Static route networking examples are provided in “Management Network Connectivity” chapter of the *Cisco ONS 15454 DWDM Reference Manual*.

Step 5 Return to your originating procedure (NTP).

DLP-G59 Set Up or Change Open Shortest Path First Protocol

Purpose	This task enables the OSPF routing protocol on the ONS 15454. Perform this task if you want to include the ONS 15454 in OSPF-enabled networks.
Tools/Equipment	None
Prerequisite Procedures	DLP-G46 Log into CTC, page 2-27 You will need the OSPF Area ID, Hello and Dead intervals, and authentication key (if OSPF authentication is enabled) provisioned on the router to which the ONS 15454 is connected.
Required/As Needed	As needed
Onsite/Remote	Onsite or remote
Security Level	Provisioning or higher

- Step 1** In node view (single-shelf mode) or multishelf view (multishelf mode), click the **Provisioning > Network > OSPF** tabs.
- Step 2** On the top left side of the OSPF area, complete the following:
- **DCC/GCC OSPF Area ID Table**—In dotted decimal format, enter the number that identifies the ONS 15454 nodes as a unique OSPF area ID. The Area ID can be any number between 000.000.000.000 and 255.255.255.255, but must be unique to the LAN OSPF area.
 - **SDCC Metric**—This value is normally unchanged. It sets a cost for sending packets across the Section DCC, which is used by OSPF routers to calculate the shortest path. This value should always be higher than the LAN metric. The default SDCC metric is 100.
 - **LDCC Metric**—Sets a cost for sending packets across the Line DCC. This value should always be lower than the SDCC metric. The default LDCC metric is 33. It is usually not changed.
- Step 3** In the OSPF on LAN area, complete the following:
- **OSPF active on LAN**—When checked, enables the ONS 15454 OSPF topology to be advertised to OSPF routers on the LAN. Enable this field on ONS 15454 nodes that directly connect to OSPF routers.
 - **LAN Port Area ID**—Enter the OSPF area ID (dotted decimal format) for the router port where the ONS 15454 is connected. (This number is different from the DCC/GCC OSPF Area ID.)
- Step 4** By default, OSPF is set to No Authentication. If the OSPF router requires authentication, complete the following steps. If not, continue with [Step 5](#).
- Click the **No Authentication** button.
 - In the Edit Authentication Key dialog box, complete the following:
 - **Type**—Choose **Simple Password**.

- Enter Authentication Key—Enter the password.
- Confirm Authentication Key—Enter the same password to confirm it.

c. Click **OK**.

The authentication button label changes to Simple Password.

Step 5 Provision the OSPF priority and interval settings.

The OSPF priority and interval defaults are the defaults most commonly used by OSPF routers. Verify that these defaults match the ones used by the OSPF router where the ONS 15454 is connected.

- Router Priority—Selects the designated router for a subnet.
- Hello Interval (sec)—Sets the number of seconds between OSPF hello packet advertisements sent by OSPF routers. Ten seconds is the default.
- Dead Interval—Sets the number of seconds that will pass while an OSPF router's packets are not visible before its neighbors declare the router down. Forty seconds is the default.
- Transit Delay (sec)—Indicates the service speed. One second is the default.
- Retransmit Interval (sec)—Sets the time that will elapse before a packet is resent. Five seconds is the default.
- LAN Metric—Sets a cost for sending packets across the LAN. This value should always be lower than the SDCC metric. Ten is the default.

Step 6 Under OSPF Area Range Table, create an area range table if one is needed:



Note Area range tables consolidate the information that is outside an OSPF area border. One ONS 15454 in the ONS 15454 OSPF area is connected to the OSPF router. An area range table on this node points the router to the other nodes that reside within the ONS 15454 OSPF area.

- Under OSPF Area Range Table, click **Create**.
- In the Create Area Range dialog box, enter the following:
 - Range Address—Enter the area IP address for the ONS 15454 nodes that reside within the OSPF area. For example, if the ONS 15454 OSPF area includes nodes with IP addresses 10.10.20.100, 10.10.30.150, 10.10.40.200, and 10.10.50.250, the range address would be 10.10.0.0.
 - Range Area ID—Enter the OSPF area ID for the ONS 15454 nodes. This is either the ID in the DCC OSPF Area ID field or the ID in the Area ID for LAN Port field.
 - Mask Length—Enter the subnet mask length. In the Range Address example, this is 16.
 - Advertise—Check if you want to advertise the OSPF range table.
- Click **OK**.

Step 7 All OSPF areas must be connected to Area 0. If the ONS 15454 OSPF area is not physically connected to Area 0, use the following steps to create a virtual link table that will provide the disconnected area with a logical path to Area 0:

- Under OSPF Virtual Link Table, click **Create**.
- In the Create Virtual Link dialog box, complete the following fields. OSPF settings must match OSPF settings for the ONS 15454 OSPF area:
 - Neighbor—The router ID of the Area 0 router.
 - Transit Delay (sec)—The service speed. One second is the default.

- Hello Int (sec)—The number of seconds between OSPF hello packet advertisements sent by OSPF routers. Ten seconds is the default.
 - Auth Type—If the router where the ONS 15454 is connected uses authentication, choose **Simple Password**. Otherwise, choose **No Authentication**.
 - Retransmit Int (sec)—Sets the time that will elapse before a packet is resent. Five seconds is the default.
 - Dead Int (sec)—Sets the number of seconds that will pass while an OSPF router's packets are not visible before its neighbors declare the router down. Forty seconds is the default.
- c. Click **OK**.
- Step 8** After entering ONS 15454 OSPF area data, click **Apply**.
If you changed the Area ID, the TCC2/TCC2P cards reset, one at a time. The reset takes approximately 10 to 15 minutes.
- Step 9** Return to your originating procedure (NTP).

DLP-G60 Set Up or Change Routing Information Protocol

Purpose	This task enables RIP on the ONS 15454. Perform this task if you want to include the ONS 15454 in RIP-enabled networks.
Tools/Equipment	None
Prerequisite Procedures	DLP-G46 Log into CTC, page 2-27 You need to create a static route to the router adjacent to the ONS 15454 for the ONS 15454 to communicate its routing information to non-DCC-connected nodes.
Required/As Needed	As needed
Onsite/Remote	Onsite or remote
Security Level	Provisioning or higher

- Step 1** In node view (single-shelf mode) or multishelf view (multishelf mode), click the **Provisioning > Network > RIP** tabs.
- Step 2** Check the **RIP Active** check box if you are activating RIP.
- Step 3** Choose either RIP Version 1 or RIP Version 2 from the drop-down list, depending on which version is supported in your network.
- Step 4** Set the RIP metric. The RIP metric can be set to a number between 1 and 15 and represents the number of hops.
- Step 5** By default, RIP is set to No Authentication. If the router that the ONS 15454 is connected to requires authentication, complete the following steps. If not, continue with [Step 6](#).
- a. Click the **No Authentication** button.
 - b. In the Edit Authentication Key dialog box, complete the following:
 - Type—Choose **Simple Password**.
 - Enter Authentication Key—Enter the password.

- Confirm Authentication Key—Enter the same password to confirm it.

c. Click **OK**.

The authentication button label changes to Simple Password.

Step 6 If you want to complete an address summary, complete the following steps. If not, continue with [Step 7](#). Complete the address summary only if the ONS 15454 is a gateway NE with multiple external ONS 15454 NEs attached with IP addresses in different subnets.

a. In the RIP Address Summary area, click **Create**.

b. In the Create Address Summary dialog box, complete the following:

- Summary Address—Enter the summary IP address.
- Mask Length—Enter the subnet mask length using the up and down arrows.
- Hops—Enter the number of hops. The smaller the number of hops, the higher the priority.

c. Click **OK**.

Step 7 Return to your originating procedure (NTP).

NTP-G341 Set Up Secure Access to the ONS 15454 TL1

Purpose	This procedure provisions ONS 15454s for secure access to TL1.
Tools/Equipment	None
Prerequisite Procedures	NTP-G26 Set Up CTC Network Access, page 3-13
Required/As Needed	As needed
Onsite/Remote	Onsite or remote
Security Level	Superuser

Step 1 In the node view, click the **Provisioning > Security > Access** pane.

Step 2 Under the **TL1 Access** area, change the **Access State** to **Secure**.

Step 3 Click **Apply**.

Existing non-secure TL1 sessions, if any, are terminated.

Step 4 To create a secure TL1 connection, enter the following command at the UNIX or Linux prompt:

```
ssh -l username node-ip -p port-number
```

The port number for secure TL1 is 4083.



Note Use any SSH client on Windows.

Stop. You have completed this procedure.

NTP-G27 Set Up the ONS 15454 for Firewall Access

Purpose	This procedure provisions ONS 15454 nodes and CTC computers for access through firewalls.
Tools/Equipment	IIOIP listener port number provided by your LAN or firewall administrator
Prerequisite Procedures	NTP-G22 Verify Common Card Installation, page 3-4
Required/As Needed	As needed
Onsite/Remote	Onsite or remote
Security Level	Provisioning or higher

- Step 1** Log into a node that is behind the firewall. See the [“DLP-G46 Log into CTC” task on page 2-27](#) for instructions. If you are already logged in, continue with Step 2.
- Step 2** If the ONS 15454 node is in a protected network and CTC computer is an external network, complete the [“DLP-G61 Provision the IIOIP Listener Port on the ONS 15454” task on page 3-26](#).

[Figure 3-6](#) shows ONS 15454 nodes in a protected network and the CTC computer in an external network. For the computer to access the ONS 15454 nodes, you must provision the IIOIP listener port specified by your firewall administrator on the ONS 15454.

Figure 3-6 Nodes Behind a Firewall

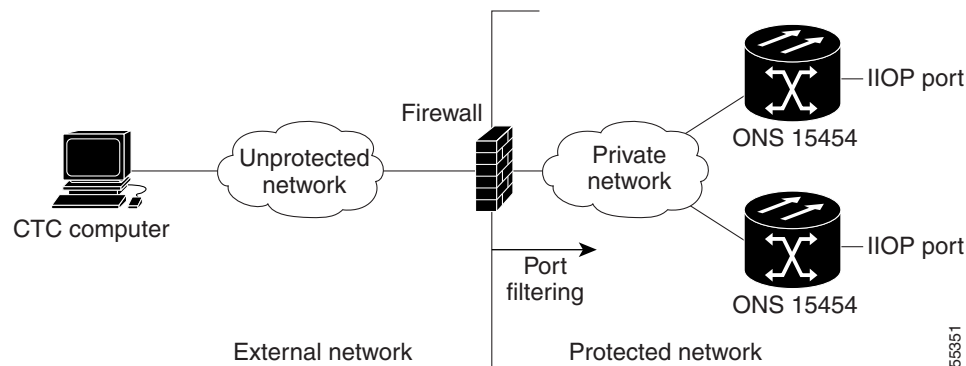

- Step 3** If the CTC computer resides behind a firewall, complete the [“DLP-G62 Provision the IIOIP Listener Port on the CTC Computer” task on page 3-27](#).

[Figure 3-7](#) shows a CTC computer and ONS 15454 behind firewalls. For the computer to access the ONS 15454, you must provision the IIOIP port on the CTC computer and on the ONS 15454.

Figure 3-7 CTC Computer and ONS 15454 Nodes Residing Behind Firewalls

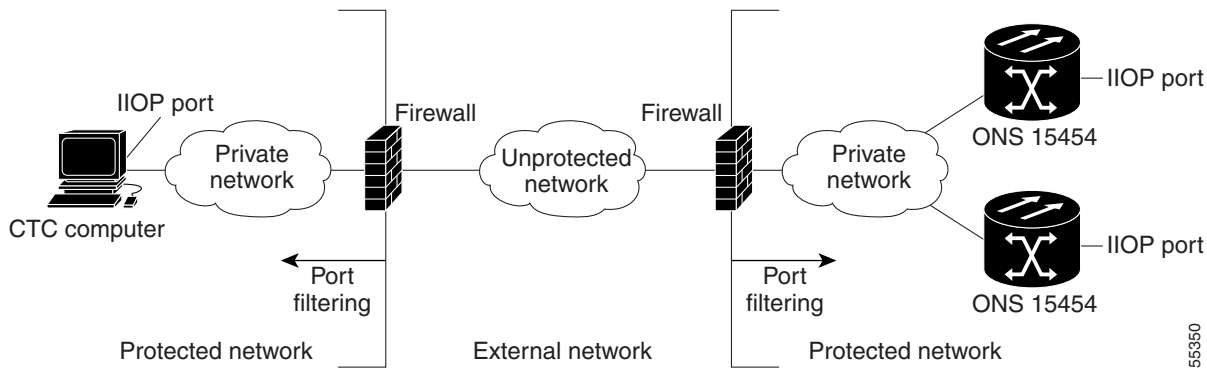

Stop. You have completed this procedure.

DLP-G61 Provision the IIOP Listener Port on the ONS 15454

Purpose	This task sets the IIOP listener port on the ONS 15454, which enables you to access ONS 15454 nodes that reside behind a firewall.
Tools/Equipment	IIOP listener port number provided by your LAN or firewall administrator
Prerequisite Procedures	DLP-G46 Log into CTC, page 2-27
Required/As Needed	As needed
Onsite/Remote	Onsite or remote
Security Level	Provisioning or higher



Note

If the Enable SOCKS proxy on port 1080 check box is checked, CTC will use port 1080 and ignore the configured IIOP port setting. If the check box is later unchecked, the configured IIOP listener port will be used.

- Step 1** In node view (single-shelf mode) or multishelf view (multishelf mode), click the **Provisioning > Security > Access** tabs.
- Step 2** In the TCC CORBA (IIOP) Listener Port area, choose a listener port option:
- **Default - TCC Fixed**—Uses Port 57790 to connect to ONS 15454 nodes on the same side of the firewall or if no firewall is used (default). This option can be used for access through a firewall if Port 57790 is open.
 - **Standard Constant**—Uses Port 683, the CORBA default port number.
 - **Other Constant**—If Port 683 is not used, type the IIOP port specified by your firewall administrator.
- Step 3** Click **Apply**.
- Step 4** When the Change Network Configuration message appears, click **Yes**.

Both ONS 15454 TCC2/TCC2P cards reboot, one at a time. The reboot takes approximately 15 minutes.

Step 5 Return to your originating procedure (NTP).

DLP-G62 Provision the IIOP Listener Port on the CTC Computer

Purpose	This task selects the IIOP listener port on CTC and must be completed if the computer running CTC resides behind a firewall.
Tools/Equipment	IIOP listener port number from LAN or firewall administrator.
Prerequisite Procedures	NTP-G22 Verify Common Card Installation, page 3-4 DLP-G46 Log into CTC, page 2-27
Required/As Needed	As needed.
Onsite/Remote	Onsite or remote
Security Level	Provisioning or higher

Step 1 From the Edit menu, choose **Preferences**.

Step 2 In the Preferences dialog box, click the **Firewall** tab.

Step 3 In the CTC CORBA (IIOP) Listener Port area, choose a listener port option:

- **Default - Variable**—Use to connect to ONS 15454 nodes from within a firewall or if no firewall is used (default).
- **Standard Constant**—Use Port 683, the CORBA default port number.
- **Other Constant**—If Port 683 is not used, enter the IIOP port defined by your administrator.

Step 4 Click **Apply**. A warning appears telling you that the port change will apply during the next CTC login.

Step 5 Click **OK**.

Step 6 In the Preferences dialog box, click **OK**.

Step 7 To access the ONS 15454 using the IIOP port, log out of CTC then log back in. (To log out, choose **Exit** from the File menu).

Step 8 Return to your originating procedure (NTP).

NTP-G132 Provision OSI

Purpose	This procedure provisions the ONS 15454 so it can be installed in networks with other vendor NEs that use the OSI protocol stack for data communications network (DCN) communications. This procedure provisions the TID Address Resolution Protocol (TARP), OSI routers, manual area addresses, subnetwork points of attachment, and IP-over-CLNS (connectionless network service) tunnels.
Tools/Equipment	None
Prerequisite Procedures	NTP-G15 Install the Common Control Cards, page 1-74
Required/As Needed	As needed
Onsite/Remote	Onsite
Security Level	Provisioning or higher



Caution

This procedure requires an understanding of OSI protocols, parameters, and functions. Before you begin, review the OSI reference sections in the “Management Network Connectivity” chapter of the *Cisco ONS 15454 DWDM Reference Manual* and ensure that you know the role of the ONS 15454 within the OSI and IP network.



Note

This procedure requires provisioning of non-ONS equipment including routers and third party NEs. Do not begin until you have the capability to complete that provisioning.

Step 1 Complete the “[DLP-G46 Log into CTC](#)” task on page 2-27 at the node where you want to provision the OSI. If you are already logged in, continue with Step 2.

Step 2 As needed, complete the following tasks:

- [DLP-G283 Provision OSI Routing Mode, page 3-29](#)—Complete this task first.
- [DLP-G284 Provision the TARP Operating Parameters, page 3-30](#)—Complete this task second.
- [DLP-G285 Add a Static TID to NSAP Entry to the TARP Data Cache, page 3-32](#)—Complete this task as needed.
- [DLP-G287 Add a TARP Manual Adjacency Table Entry, page 3-33](#)—Complete this task as needed.
- [DLP-G288 Provision OSI Routers, page 3-34](#)—Complete this task as needed.
- [DLP-G289 Provision Additional Manual Area Addresses, page 3-35](#)—Complete this task as needed.
- [DLP-G290 Enable the OSI Subnet on the LAN Interface, page 3-35](#)—Complete this task as needed.
- [DLP-G291 Create an IP-Over-CLNS Tunnel, page 3-37](#)—Complete this task as needed.

Stop. You have completed this procedure.

DLP-G283 Provision OSI Routing Mode

Purpose	This task provisions the OSI routing mode. Complete this task when the ONS 15454 is connected to networks with third party NEs that use the OSI protocol stack for DCN communication.
Tools/Equipment	None
Prerequisite Procedures	NTP-G15 Install the Common Control Cards, page 1-74 DLP-G46 Log into CTC, page 2-27
Required/As Needed	As needed
Onsite/Remote	Onsite
Security Level	Provisioning or higher



Caution

Do not complete this task until you confirm the role of the node within the network. It will be either an End System (ES), Intermediate System (IS) Level 1, or IS Level 1/Level 2. This decision must be carefully considered. For additional information about OSI provisioning, refer to the “Management Network Connectivity” chapter of the *Cisco ONS 15454 DWDM Reference Manual*.



Caution

Link State Protocol (LSP) buffers must be the same at all NEs within the network, or loss of visibility might occur. Do not modify the LSP buffers unless you confirm that all NEs within the OSI have the same buffer size.



Caution

LSP buffer sizes cannot be greater than the LAP-D maximum transmission unit (MTU) size within the OSI area.



Note

For ONS 15454 nodes, three virtual routers can be provisioned. The node primary Network Service Access Point (NSAP) address is also the Router 1 primary manual area address. To edit the primary NSAP, you must edit the Router 1 primary manual area address. After you enable Router 1 on the Routers subtab, the Change Primary Area Address button is available to edit the address.

Step 1 In node view (single-shelf mode) or multishelf view (multishelf mode), click the **Provisioning > OSI** tabs.

Step 2 Choose a routing mode:

- End System—The ONS 15454 performs OSI end system (ES) functions and relies upon an intermediate system (IS) for communication with nodes that reside within its OSI area.



Note The End System routing mode is not available if more than one virtual router is enabled.

- Intermediate System Level 1—The ONS 15454 performs OSI IS functions. It communicates with IS and ES nodes that reside within its OSI area. It depends upon an IS L1/L2 node to communicate with IS and ES nodes that reside outside its OSI area.

- Intermediate System Level 1/Level 2—The ONS 15454 performs IS functions. It communicates with IS and ES nodes that reside within its OSI area. It also communicates with IS L1/L2 nodes that reside in other OSI areas. Before choosing this option, verify the following:
 - The node is connected to another IS Level 1/Level 2 node that resides in a different OSI area.
 - The node is connected to all nodes within its area that are provisioned as IS L1/L2.

Step 3 If needed, change the LSP data buffers:

- L1 LSP Buffer Size—Adjusts the Level 1 link state PDU buffer size. The default is 512. It should not be changed.
- L2 LSP Buffer Size—Adjusts the Level 2 link state PDU buffer size. The default is 512. It should not be changed.

Step 4 Return to your originating procedure (NTP).

DLP-G284 Provision the TARP Operating Parameters

Purpose	This task provisions the TARP operating parameters including TARP protocol data unit (PDU) propagation, timers, and loop detection buffer (LDB).
Tools/Equipment	None
Prerequisite procedures	DLP-G46 Log into CTC, page 2-27
Required/As needed	As needed
Onsite/Remote	Onsite or remote
Security Level	Superuser

Step 1 In node view (single-shelf mode) or multishelf view (multishelf mode), click the **Provisioning > OSI > TARP > Config** tabs.

Step 2 Provision the following parameters, as needed:

- TARP PDUs L1 Propagation—If checked (default), TARP Type 1 PDUs that are received by the node and are not excluded by the LDB are propagated to other NEs within the Level 1 OSI area. (Type 1 PDUs request a protocol address that matches a target identifier [TID] within a Level 1 routing area.) The propagation does not occur if the NE is the target of the Type 1 PDU, and PDUs are not propagated to the NE from which the PDU was received.



Note The TARP PDUs L1 Propagation parameter is not used when the Node Routing Area (on the Provisioning > OSI > Main Setup tab) is set to End System.

- TARP PDUs L2 Propagation—If checked (default), TARP Type 2 PDUs that are received by the node and are not excluded by the LDB are propagated to other NEs within the Level 2 OSI areas. (Type 2 PDUs request a protocol address that matches a TID within a Level 2 routing area.) The propagation occurs if the NE is not the target of the Type 2 PDU, and PDUs are not propagated to the NE from which the PDU was received.



Note The TARP PDUs L2 Propagation parameter is only used when the Node Routing Area is provisioned to Intermediate System Level 1/Level 2.

- TARP PDUs Origination—If checked (default), the node performs all TARP origination functions including:
 - TID to NSAP resolution requests (originate TARP Type 1 and Type 2 PDUs)
 - NSAP to TID requests (originate Type 5 PDUs)
 - TARP address changes (originate Type 4 PDUs)



Note TARP Echo and NSAP to TID are not supported.

- TARP Data Cache—If checked (default), the node maintains a TARP data cache (TDC). The TDC is a database of TID to NSAP pairs created from TARP Type 3 PDUs received by the node and modified by TARP Type 4 PDUs (TID to NSAP updates or corrections). TARP 3 PDUs are responses to Type 1 and Type 2 PDUs. The TDC can also be populated with static entries entered on the TARP > Static TDC tab.



Note TARP Data Cache is only used when the TARP PDUs Origination parameter is enabled.

- L2 TARP Data Cache—If checked (default), the TIDs and NSAPs of NEs originating Type 2 requests are added to the TDC before the node propagates the requests to other NEs.



Note The L2 TARP Data Cache parameter is designed for Intermediate System Level 1/Level 2 nodes that are connected to other Intermediate System Level 1/Level 2 nodes. Enabling the parameter for Intermediate System Level 1 nodes is not recommended.

- LDB—If checked (default), enables the TARP loop detection buffer. The LDB prevents TARP PDUs from being sent more than once on the same subnet.



Note The LDB parameter is not used if the Node Routing Mode is provisioned to End System or if the TARP PDUs L1 Propagation parameter is not enabled.

- LAN TARP Storm Suppression—If checked (default), enables TARP storm suppression. This function prevents redundant TARP PDUs from being unnecessarily propagated across the LAN network.
- Send Type 4 PDU on Startup—If checked, a TARP Type 4 PDU is originated during the initial ONS 15454 startup. Type 4 PDUs indicate that a TID or NSAP change has occurred at the NE. (The default setting is not enabled.)
- Type 4 PDU Delay—Sets the amount of time that will pass before the Type 4 PDU is generated when Send Type 4 PDU on Startup is enabled. 60 seconds is the default. The range is 0 to 255 seconds.



Note The Send Type 4 PDU on Startup and Type 4 PDU Delay parameters are not used if TARP PDUs Origination is not enabled.

- **LDB Entry**—Sets the TARP loop detection buffer timer. The loop detection buffer time is assigned to each LDB entry for which the TARP sequence number (tar-seq) is zero. The default is 5 minutes. The range is 1 to 10 minutes.
- **LDB Flush**—Sets the frequency period for flushing the LDB. The default is 5 minutes. The range is 0 to 1440 minutes.
- **T1**—Sets the amount of time to wait for a response to a Type 1 PDU. Type 1 PDUs seek a specific NE TID within an OSI Level 1 area. The default is 15 seconds. The range is 0 to 3600 seconds.
- **T2**—Sets the amount of time to wait for a response to a Type 2 PDU. TARP Type 2 PDUs seek a specific NE TID value within OSI Level 1 and Level 2 areas. The default is 25 seconds. The range is 0 to 3600 seconds.
- **T3**—Sets the amount of time to wait for an address resolution request. The default is 40 seconds. The range is 0 to 3600 seconds.
- **T4**—Sets the amount of time to wait for an error recovery. This timer begins after the T2 timer expires without finding the requested NE TID. The default is 20 seconds. The range is 0 to 3600 seconds.



Note The T1, T2, and T4 timers are not used if TARP PDUs Origination is not enabled.

Step 3 Click **Apply**.

Step 4 Return to your originating procedure (NTP).

DLP-G285 Add a Static TID to NSAP Entry to the TARP Data Cache

Purpose	This task adds a static TID to NSAP entry to the TDC. The static entries are required for NEs that do not support TARP and are similar to static routes. For a specific TID, you must force a specific NSAP.
Tools/Equipment	None
Prerequisite procedures	DLP-G46 Log into CTC, page 2-27
Required/As needed	As needed
Onsite/Remote	Onsite or remote
Security Level	Provisioner or higher

Step 1 In node view (single-shelf mode) or multishelf view (multishelf mode), click the **Provisioning > OSI > TARP > Static TDC** tabs.

Step 2 Click **Add Static Entry**.

Step 3 In the Add Static Entry dialog box, enter the following:

- **TID**—Enter the TID of the NE. (For ONS nodes, the TID is the Node Name parameter on the node or multishelf view Provisioning > General tab.)
- **NSAP**—Enter the OSI NSAP address in the NSAP field or, if preferred, click **Use Mask** and enter the address in the Masked NSAP Entry dialog box.

- Step 4** Click **OK** to close the Masked NSAP Entry dialog box, if used, and then click **OK** to close the Add Static Entry dialog box.
- Step 5** Return to your originating procedure (NTP).
-

DLP-G287 Add a TARP Manual Adjacency Table Entry

Purpose	This task adds an entry to the TARP manual adjacency table (MAT). Entries are added to the MAT when the ONS 15454 must communicate across routers or NEs that lack TARP capability.
Tools/Equipment	None
Prerequisite procedures	DLP-G46 Log into CTC, page 2-27
Required/As needed	As needed
Onsite/Remote	Onsite or remote
Security Level	Provisioning or higher

- Step 1** In node view (single-shelf mode) or multishelf view (multishelf mode), click the **Provisioning > OSI > TARP > MAT** tabs.
- Step 2** Click **Add**.
- Step 3** In the Add TARP Manual Adjacency Table Entry dialog box, enter the following:
- **Level**—Sets the TARP Type Code that will be sent:
 - **Level 1**—Indicates that the adjacency is within the same area as the current node. The entry generates Type 1 PDUs.
 - **Level 2**—Indicates that the adjacency is in a different area than the current node. The entry generates Type 2 PDUs.
 - **NSAP**—Enter the OSI NSAP address in the NSAP field or, if preferred, click **Use Mask** and enter the address in the Masked NSAP Entry dialog box.
- Step 4** Click **OK** to close the Masked NSAP Entry dialog box, if used, and then click **OK** to close the Add Static Entry dialog box.
- Step 5** Return to your originating procedure (NTP).
-

DLP-G288 Provision OSI Routers

Purpose	This task enables an OSI router and edits its primary manual area address.
Tools/Equipment	None
Prerequisite Procedures	NTP-G22 Verify Common Card Installation, page 3-4 DLP-G46 Log into CTC, page 2-27
Required/As Needed	As needed
Onsite/Remote	Onsite or remote
Security Level	Provisioning or higher

Note

Router 1 must be enabled before you can enable and edit the primary manual area addresses for Routers 2 and 3.

Note

The Router 1 manual area address, System ID, and Selector “00” create the node NSAP address. Changing the Router 1 manual area address changes the node NSAP address.

Note

The System ID for Router 1 is the node MAC address. The System IDs for Routers 2 and 3 are created by adding 1 and 2 respectively to the Router 1 System ID. You cannot edit the System IDs.

-
- Step 1** Click the **Provisioning > OSI > Routers > Setup** tabs.
- Step 2** Chose the router you want provision and click **Edit**. The OSI Router Editor dialog box appears.
- Step 3** In the OSI Router Editor dialog box:
- Check **Enable Router** to enable the router and make its primary area address available for editing.
 - Click the manual area address, then click **Edit**.
 - In the Edit Manual Area Address dialog box, edit the primary area address in the Area Address field. If you prefer, click **Use Mask** and enter the edits in the Masked NSAP Entry dialog box. The address (hexadecimal format) can be 8 to 24 alphanumeric characters (0–9, a–f) in length.
 - Click **OK** successively to close the following dialog boxes: Masked NSAP Entry (if used), Edit Manual Area Address, and OSI Router Editor.
- Step 4** Return to your originating procedure (NTP).
-

DLP-G289 Provision Additional Manual Area Addresses

Purpose	This task provisions the OSI manual area addresses. One primary area and two additional manual areas can be created for each virtual router.
Tools/Equipment	None
Prerequisite Procedures	NTP-G22 Verify Common Card Installation, page 3-4 DLP-G288 Provision OSI Routers, page 3-34 DLP-G46 Log into CTC, page 2-27
Required/As Needed	As needed
Onsite/Remote	Onsite or remote
Security Level	Provisioning or higher

-
- Step 1** Click the **Provisioning > OSI > Routers > Setup** tabs.
- Step 2** Chose the router where you want provision an additional manual area address and click **Edit**. The OSI Router Editor dialog box appears.
- Step 3** In the OSI Router Editor dialog box:
- Check **Enable Router** to enable the router and make its primary area address available for editing.
 - Click the manual area address, then click **Add**.
 - In the Add Manual Area Address dialog box, enter the primary area address in the Area Address field. If you prefer, click **Use Mask** and enter the address in the Masked NSAP Entry dialog box. The address (hexadecimal format) can be 2 to 24 alphanumeric characters (0–9, a–f) in length.
 - Click **OK** successively to close the following dialog boxes: Masked NSAP Entry (if used), Add Manual Area Address, and OSI Router Editor.
- Step 4** Return to your originating procedure (NTP).
-

DLP-G290 Enable the OSI Subnet on the LAN Interface

Purpose	This task enables the OSI subnetwork point of attachment on the LAN interface.
Tools/Equipment	None
Prerequisite Procedures	NTP-G22 Verify Common Card Installation, page 3-4 DLP-G46 Log into CTC, page 2-27
Required/As Needed	As needed
Onsite/Remote	Onsite or remote
Security Level	Provisioning or higher



Note

When you create communication channels (OSC or GCC), OSI subnetwork points of attachment are enabled on the communication channels. See the “[NTP-G38 Provision OSC Terminations](#)” procedure on page 3-87 and the “[DLP-G76 Provision DCC/GCC Terminations](#)” task on page 7-21.

**Note**

The OSI subnetwork point of attachment cannot be enabled for the LAN interface if the OSI routing mode is set to ES.

**Note**

If Secure Mode is on, the OSI Subnet is enabled on the backplane LAN port, not the front TCC2P TCP/IP (LAN) port.

-
- Step 1** Click the **Provisioning > OSI > Routers > Subnet** tabs.
- Step 2** Click **Enable LAN Subnet**.
- Step 3** In the Enable LAN Subnet dialog box, complete the following fields:
- ESH—Sets the End System Hello (ESH) propagation frequency. An end system NE transmits ESHs to inform other ESs and ISs about the NSAPs it serves. The default is 10 seconds. The range is 10 to 1000 seconds.
 - ISH—Sets the Intermediate System Hello (ISH) PDU propagation frequency. An intermediate system NE sends ISHs to other ESs and ISs to inform them about the IS NEs it serves. The default is 10 seconds. The range is 10 to 1000 seconds.
 - IIH—Sets the Intermediate System to Intermediate System Hello (IIH) PDU propagation frequency. The IS-IS Hello PDUs establish and maintain adjacencies between ISs. The default is 3 seconds. The range is 1 to 600 seconds.
 - IS-IS Cost—Sets the cost for sending packets on the LAN subnet. The IS-IS protocol uses the cost to calculate the shortest routing path. The default IS-IS cost for LAN subnets is 20. It normally should not be changed.
 - DIS Priority—Sets the designated intermediate system (DIS) priority. In IS-IS networks, one router is elected to serve as the DIS (LAN subnets only). Cisco router DIS priority is 64. For the ONS 15454 LAN subnet, the default DIS priority is 63. It normally should not be changed.
- Step 4** Click **OK**.
- Step 5** Return to your originating procedure (NTP).
-

DLP-G291 Create an IP-Over-CLNS Tunnel

Purpose	This task creates an IP-over-Connectionless Network Service (CLNS) tunnel to allow ONS 15454 nodes to communicate across equipment and networks that use the OSI protocol stack.
Tools/Equipment	None
Prerequisite Procedures	NTP-G22 Verify Common Card Installation, page 3-4 DLP-G46 Log into CTC, page 2-27
Required/As Needed	As needed
Onsite/Remote	Onsite or remote
Security Level	Provisioning or higher



Caution

IP-over-CLNS tunnels require two endpoints. You will create one point on an ONS 15454. The other endpoint is generally provisioned on non-ONS equipment including routers and other vendor NEs. Before you begin, verify that you have the capability to create an OSI-over-CLNS tunnel on the other equipment location.

Step 1 Click the **Provisioning > OSI > Tunnels** tabs.

Step 2 Click **Create**.

Step 3 In the Create IP Over CLNS Tunnel dialog box, complete the following fields:

- Tunnel Type—Choose a tunnel type:
 - **Cisco**—Creates the proprietary Cisco IP tunnel. Cisco IP tunnels add the CLNS header to the IP packets.
 - **GRE**—Creates a Generic Routing Encapsulation tunnel. GRE tunnels add the CLNS header and a GRE header to the IP packets.

The Cisco proprietary tunnel is slightly more efficient than the GRE tunnel because it does not add the GRE header to each IP packet. The two tunnel types are not compatible. Most Cisco routers support the Cisco IP tunnel, while only a few support both GRE and Cisco IP tunnels. You generally should create Cisco IP tunnels if you are tunneling between two Cisco routers or between a Cisco router and an ONS node.



Caution

Always verify that the IP-over-CLNS tunnel type that you choose is supported by the equipment at the other end of the tunnel.

- IP Address—Enter the IP address of the IP-over-CLNS tunnel destination.
- IP Mask—Enter the IP address subnet mask of the IP-over-CLNS destination.
- OSPF Metric—Enter the OSPF metric for sending packets across the IP-over-CLNS tunnel. The OSPF metric, or cost, is used by OSPF routers to calculate the shortest path. The default is 110. Normally, it is not be changed unless you are creating multiple tunnel routes and want to prioritize routing by assigning different metrics.
- NSAP Address—Enter the destination NE or OSI router NSAP address.

Step 4 Click **OK**.

- Step 5** Provision the other tunnel endpoint using the documentation provided by the manufacturer of the third party vendor NE.
- Step 6** Return to your originating procedure (NTP).
-

NTP-G28 Set Up SNMP

Purpose	This procedure provisions the SNMP parameters so that you can use SNMP management software with the ONS 15454.
Tools/Equipment	None
Prerequisite Procedures	NTP-G22 Verify Common Card Installation, page 3-4
Required/As Needed	Required if SNMP is used at your installation.
Onsite/Remote	Onsite or remote
Security Level	Provisioning or higher

- Step 1** Complete the “[DLP-G46 Log into CTC](#)” task on page 2-27 at the node where you want to set up SNMP. If you are already logged in, continue with Step 2.
- Step 2** In node view (single-shelf mode) or multishelf view (multishelf mode), click the **Provisioning > SNMP** tabs.
- Step 3** In the Trap Destinations area, click **Create**.
- Step 4** Complete the following in the Create SNMP Trap Destination dialog box ([Figure 3-8](#)):
- Destination IP Address—Type the IP address of your network management system (NMS). If the node you are logged into is an ENE, set the destination address to the GNE.
 - Community—Type the SNMP community name. For a description of SNMP community names, refer to the “SNMP” chapter in the *Cisco ONS 15454 DWDM Reference Manual*.



Note The community name is a form of authentication and access control. The community name assigned to the ONS 15454 is case-sensitive and must match the community name of the NMS.

- UDP Port—The default User Datagram Protocol (UDP) port for SNMP is 162.
- Trap Version—Choose either SNMPv1 or SNMPv2. Refer to your NMS documentation to determine which version to use.

Figure 3-8 Creating an SNMP Trap

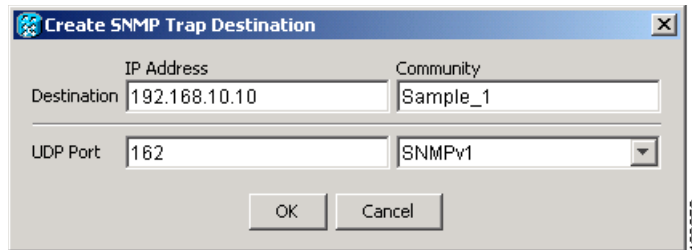

- Step 5** Click **OK**. The node IP address of the node where you provisioned the new trap destination appears in the Trap Destinations area.
- Step 6** Click the node IP address in the Trap Destinations area. Verify the SNMP information that appears in the Selected Destination list.
- Step 7** If you want the SNMP agent to accept SNMP SET requests on certain MIBs, click the **Allow SNMP Sets** check box. If this box is not checked, SET requests are rejected.
- Step 8** If you want to set up the SNMP proxy feature to allow network management, message reporting, and performance statistic retrieval across ONS firewalls, click the **Allow SNMP Proxy** check box located on the SNMP tab.



Note The Use Generic MIB check box is normally not checked for MSTP. It is checked only when the ONS 15454 resides in networks with multiple ONS products, and the network management system requires MIBs with the same name to have the same object IDs. By default, the ONS 15454 uses the CERENT-454-MIBs. Other ONS products, such as the ONS 15600, the ONS 15327, and ONS 15310-CL, use the CERENT-GENERIC-MIBs. If Use Generic MIB is checked, the ONS 15454 will use the CERENT-GENERIC-MIBs so the object IDs will be the same for all products.



Note Using the ONS firewall proxy feature effectively breaches the ONS firewall to exchange management information.

For more information about the SNMP proxy feature, refer to the “SNMP” chapter in the *Cisco ONS 15454 DWDM Reference Manual*.

- Step 9** Click **Apply**.
- Step 10** If you are setting up SNMP proxies, you can set up to three relays that send SNMP trap error counts back to the NE for each trap destination address:
- a. Click the first trap destination IP address. The address and its community name appear in the Destination fields.
 - b. Enter up to three SNMP Proxy relay addresses and community names in the fields for Relay A, Relay B, and Relay C.



Note The community names specified for each relay node must match one of the provisioned SNMP community names in the NE.

**Note**

The SNMP proxy directs SNMP traps from this node through IpA to IpB to IpC to the trap destination. Ensure that you enter the IP addresses in the correct order so that this sequence runs correctly.

Step 11 Click **Apply**.

Stop. You have completed this procedure.

NTP-G143 Import the Cisco MetroPlanner NE Update Configuration File

Purpose	This procedure imports the Cisco MetroPlanner NE Update configuration file. The configuration file, which is provided in XML format, provisions the shelf layout, sets the OPT-AMP-L mode (if present), and installs the automatic node setup (ANS) parameters calculated by Cisco MetroPlanner.
Tools/Equipment	A Cisco MetroPlanner node setup file for the network where the node is installed must be accessible to the CTC computer.
Prerequisite Procedures	NTP-G139 Verify Cisco MetroPlanner Reports and Files, page 3-3
Required/As Needed	Required
Onsite/Remote	Onsite or remote
Security Level	Superuser

**Caution**

Verify that you have the correct Cisco MetroPlanner network file before you begin this procedure. The file will have an XML extension and a name assigned by your network planner. Check with your network planner or administrator if you have any questions.

**Note**

The Cisco MetroPlanner configuration file contains parameters for the node, shelf, card type, port (including card's wavelength), and pluggable port module (PPM). Only the values present in XML format appear in the configuration file parameters; if the values are not in XML format, a column appears blank. The XML file values are independently reported and do not affect any configuration changes you apply.

**Note**

The NE Update configuration file does not provision TXP and MXP card TCA thresholds. You must provision the thresholds manually. Refer to [Chapter 5, "Provision Transponder and Muxponder Cards."](#)

Step 1 Complete the ["DLP-G46 Log into CTC" task on page 2-27](#) at the node where you want to import the Cisco MetroPlanner configuration file. If you are already logged in, continue with [Step 2](#).

Step 2 If you will choose the Provision Node Layout option to preprovision the cards in the shelf, complete the following steps. If not, continue with [Step 3](#).

- a. Display the node in node view (single-shelf mode) or multishelf view (multishelf mode).

- b. Verify that two TCC2/TCC2P cards are the only cards installed. If in multishelf mode, verify that each shelf in the multishelf has two TCC2/TCC2P cards.
 - If two TCC2/TCC2P cards are the only cards installed, continue with [Step 3](#).
 - If other cards appear, continue with [Step c](#).
 - c. If a physical card is installed, remove it from the shelf.
 - d. Delete the preprovisioned cards using the “[DLP-G351 Delete a Card in CTC](#)” task on [page 3-43](#), then repeat [Steps a](#) and [b](#).
- Step 3** If you have not created a log file to record the results of the NE update, complete the following steps. If a log file has been created, continue with [Step 4](#),
- a. Open a text editor or word processing application.
 - b. Create a new text (.TXT) document with a file name of your choosing.
 - c. Save the document in a directory that is easy to navigate to from CTC.
- Step 4** In CTC node view (single-shelf mode) or multishelf view, click the **Provisioning > WDM-ANS > Node Setup** tabs.
- Step 5** In the field under Select XML file, type the path to the Cisco MetroPlanner node setup file containing the parameters for the network where your node resides, or click **Browse** and navigate to the file on your computer or network server. Click the file, then click **Open**. The file will have an XML extension.
- Step 6** In the field under Select Log file, type the path to the text file created in [Step 3](#) where you want the node setup results recorded, or click **Browse** and navigate to the file on your computer or a network server.
-  **Note** Each node setup session overwrites the log file contents. If you want to save the results, save the log file with new name.
-
- Step 7** Click **Apply**. Either the Node Setup Selection for *node name* or Node Setup for *node name* will appear, where *node name* is the name of the node where you are importing the Cisco MetroPlanner configuration file. In a node with multishelf setup containing DWDM units, the top shelf is labeled as *node name_1*. All the other shelves are labelled as *node name_2*, *node name_3* and so on.
- Step 8** If the Node Setup Selection for *node name* page appears, complete the following steps. If not, continue with [Step 9](#).
- a. Choose the node profile that you want to apply to the node. The Cisco MetroPlanner XML file contains profiles for all nodes in the network. Choose the profile that applies to the node you are provisioning.
 - b. Click **Next**.
- Step 9** On the Node Setup for *node name* page, choose one or more of the following:
- Provision Node Layout—Preprovisions the slots in CTC for the cards required by the network plan. Choose this option when no DWDM cards are installed. (Errors will occur if cards are installed or the slots are preprovisioned.) Preprovisioning the slots before the physical cards are installed ensures that card installers place the cards in the correct slots. Preprovisioning the slots is also useful if you want to set up the network prior to card installation.
 - Provision Card Parameters—This option is available only when an OPT-AMP-L card will be installed. If you check the box, ANS provisions the OPT-AMP-L role, either as an L-band booster amplifier (OPT-LINE) or an L-band preamplifier (OPT-PRE).

- Provision ANS Parameters—If checked, installs the ANS parameters. ANS parameters provision the values required for the node to function within the specified network design. ANS parameters include span losses, optical power, optics thresholds, amplifier working mode, gain, tilt, and many others. Refer to the “Node Reference” chapter in the *Cisco ONS 15454 DWDM Reference Manual* for a list of ONS 15454 ANS parameters.



Note If you are importing the Cisco MetroPlanner configuration file for the first time, you normally choose all three options.

- Skip Interactive Mode—If checked, CTC provisions all the chosen setup components automatically without allowing you to view the results after each one.

Step 10 Click **Next**. The wizard page that appears depends on the options chosen in [Step 9](#):

- If you chose Skip Interactive Mode, continue with [Step 15](#).
- If you chose Provision Node Layout (regardless of whether you chose Provision Card Parameters and/or Provision ANS Parameters), continue with [Step 11](#).
- If you chose Provision Card Parameters, but not Provision Node Layout, continue with [Step 13](#).
- If you chose Provision ANS Parameters, but not Provision Node Layout or Provision ANS Parameters, continue with [Step 14](#).

Step 11 View the cards and slots on the left side of the page and verify that they are the same as the layout in the Cisco MetroPlanner Shelf Layout (see [Table 3-1 on page 3-3](#)). If the cards and slots match, click **Apply**. If not, click **Cancel**, and contact your next level of support to verify that you have the correct node setup file. If the site has a multishelf configuration, click **Next** and repeat this step for each shelf at the site.

CTC preprovisions the slots. (This might take a few seconds.) The results appear in the Log window. Slots that are successfully provisioned display an “Applied” status. A “Slot not empty” status appears if slots cannot be provisioned because a card is physically installed or the slot is already provisioned. If this occurs, complete the following steps. Otherwise, continue with [Step 12](#).

- Click **Cancel**, then click **Yes** at the confirmation. The slot preprovisioning does not revert when you click **Cancel**.
- If a physical card is installed, remove it from the shelf.
- Perform one of the following steps:
 - Delete all the preprovisioned slots using the “DLP-G351 Delete a Card in CTC” task on [page 3-43](#), then repeat Steps 2 through 11.
 - Delete the slot where the Slot Not Empty error occurred using the “DLP-G351 Delete a Card in CTC” task on [page 3-43](#). Complete the “DLP-G353 Preprovision a Single Slot” task on [page 3-44](#) to provision the slot manually, then repeat Steps 2 through 11 making sure to uncheck the Provision Node Layout option in [Step 9](#).



Note When you preprovision a slot, the card is purple in the CTC shelf graphic and an NP (not present) appears on the card. After the physical card is installed, the card changes to white and the NP is removed in the CTC shelf graphic.

Step 12 Choose one of the following steps, based on the choices made in [Step 9](#):

- If you chose Provision Card Parameters with or without Provision ANS Parameters, continue with [Step 13](#).
- If you chose Provision ANS Parameters, but not Provision Card Parameters, continue with [Step 14](#).

- If you chose Provision Node only, continue with [Step 15](#).
- Step 13** Click **Next**. On the Card Parameters page, review the OPT-AMP-L role(s) indicated under the Value column, either PRE_AMPL (L-band optical preamplifier) or BST_AMPL (L band optical booster), then click **Apply**.
- Step 14** If the Provision ANS Parameters box was chosen in [Step 9](#), complete the following steps. If not, continue with [Step 15](#).
- a. Click **Next**.
 - b. Review the ANS parameters on the left half of the page.
 - c. Click **Apply**. The log file will display the results. At the end, a Done status will appear. If a parameter could not be applied, a Setting Refused status appears. If this occurs, contact your next level of support.
- Step 15** Click **Finish**, then click **OK** in the Wizard Complete confirmation dialog box.



Note MS-ISC-100T cards are not provisioned by Cisco MetroPlanner.

Stop. You have completed this procedure.

DLP-G351 Delete a Card in CTC

Purpose	This task deletes a card from an ONS 15454 slot that is provisioned in CTC.
Tools/Equipment	None
Prerequisite Procedures	“DLP-G46 Log into CTC” task on page 2-27
Required/As Needed	As needed
Onsite/Remote	Onsite or remote
Security Level	Superuser



Note It is recommended that the card be physically removed from its slot before deleting it from CTC.

- Step 1** Verify that the following conditions are not present. (During node turn-up, these conditions are normally not present):
- The card is a TCC2/TCC2P card.
 - The card is part of a protection group
 - The card has optical channels or overhead circuits provisioned.
 - The card is being used for timing.
 - The card has an optical service channel (OSC)/generic communications channel (GCC) termination.
- If any of these conditions exist, do not continue. You will not be able to delete the card until the card is removed from protection groups; circuits, DCC, and GCCs are deleted; and a different timing source is provisioned.
- To replace a TCC2/TCC2P card, refer to the *Cisco ONS 15454 DWDM Troubleshooting Guide*.

- To delete a protection group, see the “[NTP-G83 Modify or Delete Card Protection Settings](#)” procedure on page 10-34.
- To delete optical channels see the “[DLP-G347 Delete Optical Channel Client Connections](#)” task on page 7-8 and the “[DLP-G106 Delete Optical Channel Network Connections](#)” task on page 7-13; to delete overhead circuits, see the “[DLP-G112 Delete Overhead Circuits](#)” task on page 7-28.
- To remove the card as a timing source, see the “[NTP-G87 Change Node Timing Parameters](#)” procedure on page 10-47.
- To remove OSC or GCC terminations, see the “[NTP-G85 Modify or Delete OSC Terminations, DCC/GCC Terminations, and Provisionable Patchcords](#)” procedure on page 10-42

Step 2 On the shelf graphic in CTC, right-click the card that you want to remove and choose **Delete Card**.



Note If you delete a card in CTC but do not remove it from the shelf, it will reboot and reappear in CTC.

Step 3 Return to your originating procedure (NTP).

DLP-G353 Preprovision a Single Slot

Purpose	This procedure preprovisions a single ONS 15454 slot in CTC. Preprovisioning all the slots in the shelf is normally performed when you complete the “ NTP-G143 Import the Cisco MetroPlanner NE Update Configuration File ” procedure on page 3-40. Use this task if you need to manually preprovision a single slot. All slot preprovisioning must be based upon the Cisco MetroPlanner shelf layout prepared for your site.
Tools/Equipment	Cisco MetroPlanner shelf layout table or JPG file.
Prerequisite Procedures	NTP-G139 Verify Cisco MetroPlanner Reports and Files , page 3-3 DLP-G46 Log into CTC , page 2-27
Required/As Needed	As needed
Onsite/Remote	Onsite or remote
Security Level	Provisioning or higher

Step 1 In node view (single-shelf mode) or multishelf view (multishelf mode), right-click an empty slot where you will install a card.

Step 2 From the Add Card shortcut menu, choose the card type that will be installed based on the Cisco MetroPlanner shelf layout (see [Table 3-1 on page 3-3](#)). Only cards that can be installed in the slot appear in the Add Card shortcut menu. The OPT-AMP-L, 32WSS, 32-MUX-O, and 32-DMX-O cards require two vacant slots, or they will not appear in the shortcut menu. [Table 3-2](#) shows the Add Card shortcut menu items, submenu items, and the card groups and menu options/cards that they reference.

Table 3-2 CTC Add Card Shortcut Menu for DWDM Cards

Menu Item	Submenu Category	Card Group	Submenu item	Card(s)
DWDM	nXP	Transponder and Muxponder	MXPP_MR_2.5G	MXPP_MR_2.5G
			MXP_2.5G_10E	MXP_2.5G_10E MXP_2.5G_10E_C MXP_2.5G_10E_L
			MXP_2.5G_10G	MXP_2.5G_10G
			MXP_MR_10DME	MXP_MR_10DME_C MXP_MR_10DME_L
			MXP_MR_2.5G	MXP_MR_2.5G
			TXPP_MR_2.5G	TXPP_MR_2.5G
			TXP_MR_10E	TXP_MR_10E TXP_MR_10E_C TXP_MR_10E_L
			TXP_MR_10G	TXP_MR_10G
			TXP_MR_2.5G	TXP_MR_2.5G
	MD	Multiplexer and Demultiplexer	32 DMX	32DMX
			32 DMX L	32DMX-L
			32 DMXO	32DMX-O
			32 MUXO	32MUX-O
			32 WSS	32WSS
			32 WSS L	32WSS-L
			4MD	4MD-xx.x
	OSC	Optical Service Channel	MMU	MMU
			OSC + Combiner/Separator	OSC-CSM
	OADM	Optical Add/Drop Multiplexer	AD-1B	AD-1B-xx.x
AD-1C			AD-1C-xx.x	
AD-2C			AD-2C-xx.x	
AD-4B			AD-4B-xx.x	
AD-4C			AD-4C-xx.x	
Ampli	Optical Amplifier	OPT-BST	OPT-BST	
		OPT-BST E	OPT-BST-E	
		OPT-BST L	OPT-BST-L	
		OPT-PRE	OPT-PRE	
		Optical Amplifier L	OPT-AMP-L	

Table 3-2 CTC Add Card Shortcut Menu for DWDM Cards (continued)

Menu Item	Submenu Category	Card Group	Submenu item	Card(s)
Ethernet	—	—	MS-ISC-100T	MS-ISC-100T G1000
OSCM	—	—	—	OSCM (Slots 8 and 10 only)



Note When you preprovision a slot, the card appears purple in the CTC shelf graphic, rather than white when a card is installed in the slot. NP (not present) on the card graphic indicates that the card is not physically installed.

- Step 3** Repeat [Step 2](#) until all the cards shown in the Cisco MetroPlanner shelf layout are provisioned in CTC.
- Stop. You have completed this procedure.**
-

NTP-G30 Install the DWDM Cards

Purpose	This procedure describes how to install DWDM cards (OPT-PRE, OPT-BST, OPT-BST-E, OPT-BST-L, OPT-AMP-L, 32MUX-O, 32DMX-O, 32DMX, 32DMX-L, 32WSS, 32WSS-L, MMU, 4MD-xx.x, AD-1C-xx.x, AD-2C-xx.x, AD-4C-xx.x, AD-1B-xx.x, AD-4B-xx.x, OSCM, and OSC-CSM).
Tools/Equipment	<ul style="list-style-type: none"> • Cisco MetroPlanner shelf layout • The following cards, as required by your site plan: OPT-PRE, OPT-BST, OPT-BST-E, OPT-BST-L, OPT-AMP-L, 32MUX-O, 32DMX-O, 32DMX, 32DMX-L, 32WSS, 32WSS-L, MMU, 4MD-xx.x, AD-1C-xx.x, AD-2C-xx.x, AD-4C-xx.x, AD-1B-xx.x, AD-4B-xx.x, OSCM, and OSC-CSM cards (as applicable) • The ONS 15454 NE defaults file if the node will use custom NE defaults
Prerequisite Procedures	NTP-G15 Install the Common Control Cards, page 1-74 NTP-G14 Install DWDM Equipment, page 1-66 NTP-G139 Verify Cisco MetroPlanner Reports and Files, page 3-3 NTP-G143 Import the Cisco MetroPlanner NE Update Configuration File, page 3-40
Required/As Needed	As needed
Onsite/Remote	Onsite
Security Level	Provisioning or higher



Warning

This warning symbol means danger. You are in a situation that could cause bodily injury. Before you work on any equipment, be aware of the hazards involved with electrical circuitry and be familiar with standard practices for preventing accidents. To see translations of the warnings that appear in this publication, refer to the Regulatory Compliance and Safety Information document for the appropriate Cisco chassis. Statement 274



Warning

During this procedure, wear grounding wrist straps to avoid ESD damage to the card. Do not directly touch the backplane with your hand or any metal tool, or you could shock yourself. Statement 94



Warning

Class I (CDRH) and Class 1M (IEC) laser products. Statement 1055



Warning

Invisible laser radiation may be emitted from the end of the unterminated fiber cable or connector. Do not view directly with optical instruments. Viewing the laser output with certain optical instruments (for example, eye loupes, magnifiers, and microscopes) within a distance of 100 mm may pose an eye hazard. Statement 1056

**Warning**

High-performance devices on this card can get hot during operation. To remove the card, hold it by the faceplate and bottom edge. Allow the card to cool before touching any other part of it or before placing it in an antistatic bag. Statement 201

**Caution**

Always use the supplied ESD wristband when working with a powered ONS 15454. Plug the wristband cable into the ESD jack located on the lower-right outside edge of the shelf assembly.

**Note**

For US installations, complies with the US Federal Drug Administration Code of Federal Regulations Title 21, Sections 1040.10 and 1040.11, except for deviations pursuant to Laser Notice No. 50, dated July 26, 2001.

**Note**

If protective clips are installed on the backplane connectors of the cards, remove the clips before installing the cards.

**Note**

If you install a card incorrectly, the FAIL LED flashes continuously.

Step 1

If the node requires a custom network element (NE) default settings to be installed on the node, complete the [“NTP-G136 Import Network Element Defaults” procedure on page 13-43](#). If not, continue with [Step 2](#). (For information about the ONS 15454 NE defaults, refer to the “Network Elements Defaults” appendix in the *Cisco ONS 15454 DWDM Reference Manual*.)

**Caution**

If custom NE defaults are required, they must be installed before you install the DWDM cards.

Step 2

Verify that you have one of the following guides for the DWDM card installation:

- The slots that were preprovisioned when you completed the [“NTP-G143 Import the Cisco MetroPlanner NE Update Configuration File” procedure on page 3-40](#).
- The Cisco MetroPlanner shelf layout report (see [Table 3-1 on page 3-3](#)).

Step 3

If the slots are preprovisioned, continue with [Step 4](#). If you are using the Cisco MetroPlanner shelf layout report, complete the [“DLP-G348 Use the Cisco MetroPlanner Shelf Layout Report” task on page 3-50](#).

Step 4

Remove a DWDM card from its packaging, then remove the protective caps from the backplane connectors. (Safety caps are typically yellow.)

Step 5

Open the card latches/ejectors.

Step 6

Use the latches/ejectors to firmly slide the card along the slot guide rails until the card plugs into the receptacle at the back of the slot. The correct slot is designated by the Cisco MetroPlanner shelf layout.

Step 7

Verify that the card is inserted correctly. Simultaneously close the latches/ejectors on the card.

**Note**

It is possible to close the latches/ejectors when the card is not completely plugged in. Ensure that you cannot insert the card any further.

After installing the card, the following LED activity will occur:

- The card's LEDs will go through a sequence of activities (turn on, turn off, blinking.) This will take 2-3 minutes.
- The ACT LED turns on.
- The signal fail (SF) LED might persist until all card ports connect to their far-end counterparts and a signal is present.

Step 8 If the card does not boot up properly, or the LED activity is not similar to the activity in [Step 7](#), check the following:

- When a physical card type does not match the type of card provisioned for that slot in CTC, the card might not boot. If a DWDM card does not boot, open CTC and ensure that the slot is not provisioned for a different card type before assuming that the card is faulty.
- If the red FAIL LED does not turn on, check the power.
- If you insert a card into a slot provisioned for a different card, all LEDs turn off and a minor equipment mismatch alarm appears on the CTC Alarms tab.
- If the red FAIL LED is on continuously or the LEDs behave erratically, the card is not installed.

If any of conditions are present, remove the card and repeat Steps 4 to 7. If the card does not boot up properly the second time, it might be defective. Contact your next level of support.

Step 9 Repeat Steps 4 through 8 until all the DWDM cards are installed in the node.

Step 10 If OPT-PRE cards are installed, complete one of the following steps for each OPT-PRE card based on the Cisco MetroPlanner shelf layout. If OPT-PRE cards are not installed, you have completed this procedure.

- If the Cisco MetroPlanner shelf layout does not include dispersion compensating units (DCUs), install a patchcord and 4-dB attenuator with a tolerance of +/-1 dB between the OPT-PRE DC TX and RX ports for each OPT-PRE card installed in the shelf.
- If the shelf layout includes DCUs, complete the "[NTP-G31 Install the DWDM Dispersion Compensating Units](#)" procedure on page 3-51 for each side of the shelf that requires a DCU.

Stop. You have completed this procedure.

DLP-G348 Use the Cisco MetroPlanner Shelf Layout Report

Purpose	This task describes how to use the Cisco MetroPlanner shelf layout report to install cards in a DWDM node.
Tools/Equipment	None
Prerequisite Procedures	NTP-G139 Verify Cisco MetroPlanner Reports and Files, page 3-3
Required/As Needed	As needed
Onsite/Remote	Onsite
Security Level	Provisioning or higher

- Step 1** Display the Cisco MetroPlanner shelf layout report for your site. The report can be viewed in Cisco MetroPlanner (see [Figure 3-9](#)). It can also be viewed as a JPG graphic in a web browser. Refer to the *Cisco MetroPlanner DWDM Operations Guide, Release 7.0* for information about generating shelf layout reports.

Figure 3-9 Cisco MetroPlanner Shelf Layout Report Displayed in Cisco MetroPlanner

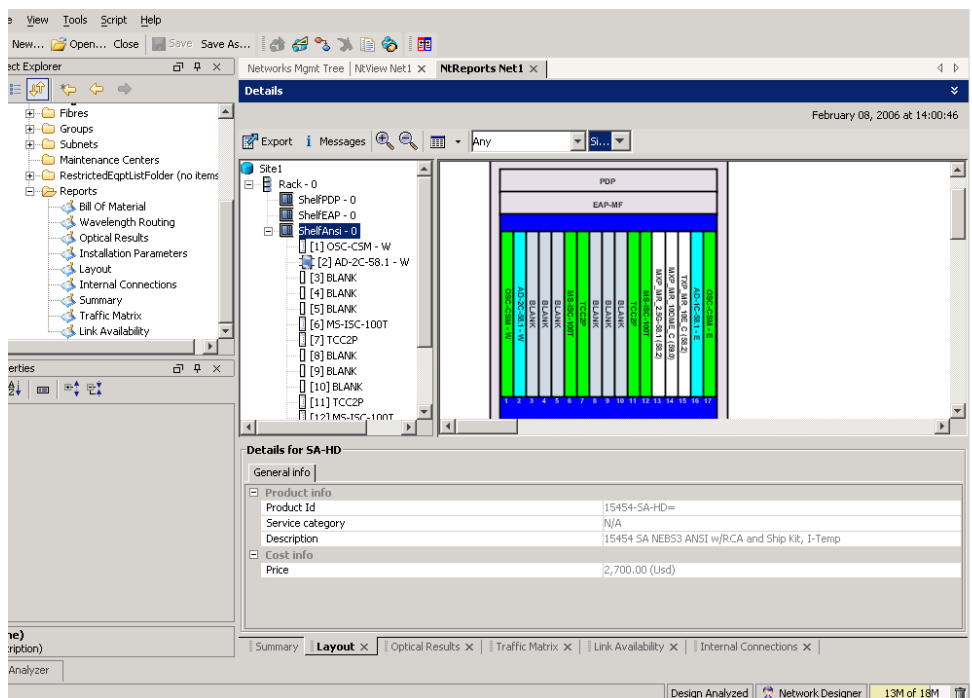

- Step 2** Review the following installation information:
- **Rack**—Indicates the rack in the node where the cards must be installed.
 - **Shelf**—Indicates the shelf in the rack where the cards must be installed. Shelf options include:
 - **Flex Shelf**—The ONS 15216 FlexLayer mechanical shelf houses Y-cable modules. Flex shelf positions are numbered 1 to 4 from left to right.
 - **DCU Shelf**—The Cisco ONS 15216 dispersion compensation shelf assembly houses dispersion compensation units (DCUs). DCU positions are numbered 1 to 2 from left to right.

- Shelf-ANSI-*n* or Shelf-ETSI-*n*—The ONS 15454 shelf assembly used to house ONS 15454 common, DWDM, and client cards. Positions in this type of shelf are numbered 1 to 17 from left to right. Multiple shelves may appear.
- Slot—Indicates the slot in the specific shelf where the cards must be installed:
 - Unit Name (Product ID)— Identifies the card by its Product ID.
 - Unit Description—Identifies the card by its name.
- Unit Side—Identifies the direction, east or west, that the specific card is serving.
- Unit Plug-in Modules—Identifies the type and number of pluggable port modules (PPMs) that will be used with specific TXP or MXP cards.

Step 3 Return to your originating procedure (NTP).

NTP-G31 Install the DWDM Dispersion Compensating Units

Purpose	This procedure describes how to install the dispersion compensating units (DCUs) for DWDM shelves.
Tools/Equipment	DCUs
Prerequisite Procedures	NTP-G15 Install the Common Control Cards, page 1-74 NTP-G14 Install DWDM Equipment, page 1-66 NTP-G30 Install the DWDM Cards, page 3-47 NTP-G139 Verify Cisco MetroPlanner Reports and Files, page 3-3
Required/As Needed	As needed
Onsite/Remote	Onsite
Security Level	Provisioning or higher



Warning

Class I (CDRH) and Class 1M (IEC) laser products. Statement 1055



Warning

Invisible laser radiation may be emitted from the end of the unterminated fiber cable or connector. Do not view directly with optical instruments. Viewing the laser output with certain optical instruments (for example, eye loupes, magnifiers, and microscopes) within a distance of 100 mm may pose an eye hazard. Statement 1056



Caution

Always use the supplied ESD wristband when working with a powered ONS 15454. Plug the wristband cable into the ESD jack located on the lower-right side of the shelf assembly.



Note

For US installations, complies with the US Federal Drug Administration Code of Federal Regulations Title 21, Sections 1040.10 and 1040.11, except for deviations pursuant to Laser Notice No. 50, dated July 26, 2001.

Step 1 Use both hands to push the DCU all the way into the chassis until the connector spring lock on the right side of the module clicks into place.

Step 2 Open the cover with the laser warning on the connector adapter and then connect the cable connector.



Note The west DCU is commonly installed on the left side and the east DCU is commonly installed on the right side.



Note Double-check the placement of the DCU card(s) with your Cisco MetroPlanner shelf layout. If you install the wrong DCU in a slot, remove the DCU and install the correct one.

Stop. You have completed this procedure.

NTP-G32 Install the Transponder and Muxponder Cards

Purpose	This procedure describes how to install the ONS 15454 TXP and MXP cards.
Tools/Equipment	TXP_MR_10G, TXP_MR_10E, TXP_MR_10E_C, TXP_MR_10E_L, TXP_MR_2.5G, TXPP_MR_2.5G, MXP_2.5G_10G, MXP_2.5G_10E, MXP_2.5G_10E_C, MXP_2.5G_10E_L, MXP_MR_2.5G, MXPP_MR_2.5G, MXP_MR_10DME_C, and MXP_MR_10DME_L cards (as applicable)
Prerequisite Procedures	NTP-G15 Install the Common Control Cards, page 1-74 NTP-G14 Install DWDM Equipment, page 1-66 NTP-G139 Verify Cisco MetroPlanner Reports and Files, page 3-3
Required/As Needed	As needed
Onsite/Remote	Onsite
Security Level	None



Warning

During this procedure, wear grounding wrist straps to avoid ESD damage to the card. Do not directly touch the backplane with your hand or any metal tool, or you could shock yourself. Statement 94



Warning

Class 1 laser product. Statement 1008



Warning

Invisible laser radiation may be emitted from the end of the unterminated fiber cable or connector. Do not view directly with optical instruments. Viewing the laser output with certain optical instruments (for example, eye loupes, magnifiers, and microscopes) within a distance of 100 mm may pose an eye hazard. Statement 1056

Warning

Class I (CDRH) and Class 1M (IEC) laser products. Statement 1055

Caution

Always use the supplied ESD wristband when working with a powered ONS 15454. Plug the wristband cable into the ESD jack located on the lower-right outside edge of the shelf assembly.



Note

For US installations, complies with the US Federal Drug Administration Code of Federal Regulations Title 21, Sections 1040.10 and 1040.11, except for deviations pursuant to Laser Notice No. 50, dated July 26, 2001.



Note

If protective clips are installed on the backplane connectors of the cards, remove the clips before installing the cards.



Note

If you install a card incorrectly, the FAIL LED flashes continuously.

- Step 1** Display Cisco MetroPlanner shelf layout (see [Table 3-1 on page 3-3](#)) for the node where you will install the TXP and MXP cards.
- Step 2** Remove the TXP or MXP card from its packaging, then remove the protective clips from the backplane connectors.
- Step 3** Open the card latches/ejectors.
- Step 4** Use the latches/ejectors to firmly slide the TXP or MXP card along the guide rails until the card plugs into the receptacle at the back of the slot designated by the Cisco MetroPlanner shelf layout.
- Step 5** Verify that the card is inserted correctly and simultaneously close the latches/ejectors on the card.



Note

It is possible to close the latches and ejectors when the card is not completely plugged into the backplane. Ensure that you cannot insert the card any further.



Note

If you install the card in the wrong slot, open the latches, slide the card out, then insert it in the correct slot.

After you install the card, the FAIL, ACT, and SF LEDs will go through a sequence of activities. They will turn on, turn off, and blink at different points. After approximately 2-3 minutes, the ACT or ACT/STBY LED turns on. The SF LED might persist until all card ports connect to their far-end counterparts and a signal is present.



Note

Until a TXP or MXP is provisioned, the card is in the standby condition and the ACT/STBY LED remains amber in color.

- Step 6** If the card does not boot up properly or the LEDs do not progress through the activities described in [Step 5](#), check the following:
- When a physical card type does not match the type of card provisioned for that slot in CTC, the card might not boot. If a TXP or MXP card does not boot, open CTC and ensure that the slot is not provisioned for a different card type before assuming that the card is faulty.
 - If the red FAIL LED does not turn on, check the power.
 - If you insert a card into a slot provisioned for a different card, all LEDs turn off.
 - If the red FAIL LED is on continuously or the LEDs behave erratically, the card is not installed properly.

If any of these conditions are present, remove the card and repeat Steps 3 to 5. If the card does not boot up properly the second time, contact your next level of support.

- Step 7** If the TXP or MXP requires a Small Form-factor Pluggable (SFP or XFP) connector, complete one of the following tasks:
- [DLP-G63 Install an SFP or XFP, page 3-55](#)—Complete this task to install the physical SFP or XFP into the TXP or MXP.
 - [DLP-G273 Preprovision an SFP or XFP Slot, page 3-56](#)—(Optional) Complete this task if you do not have the physical SFP or XFP and need to preprovision the SFP or XFP slot.



Note SFPs/XFPs are hot-swappable input/output devices that plug into a TXP, MXP, or line card port to link the port with the fiber-optic network. For more information about SFPs and XFPs, refer “Hardware Specifications” chapter in the *Cisco ONS 15454 DWDM Reference Manual*, or the *Installing GBIC, SFP and XFP Optics Modules in Cisco ONS 15454, 15454 SDH, 15327, 15600, and 15310-CL Platforms* document available in the ONS 15454 production documentation website on www.cisco.com.



Note Pluggable port module (PPM) provisioning determines how the SFPs and XFPs are used in CTC. PPM provisioning procedures are provided in [Chapter 5, “Provision Transponder and Muxponder Cards.”](#)

- Step 8** If you need to remove an SFP or XFP, complete the “[DLP-G64 Remove an SFP or XFP](#)” task on [page 3-57](#).



Note You will provision the TXP and MXP cards after you complete all node turn-up procedures. TXP and MXP provisioning procedures are provided in [Chapter 5, “Provision Transponder and Muxponder Cards.”](#)



Note Until a TXP or MXP is provisioned, the card is in the standby condition and the ACT/STBY LED remains amber in color.

Stop. You have completed this procedure.

DLP-G63 Install an SFP or XFP

Purpose	This task installs SFPs and XFPs into TXP and MXP cards. SFPs and XFPs provide a fiber interface to the card.
Tools/Equipment	None
Prerequisite Procedures	NTP-G32 Install the Transponder and Muxponder Cards, page 3-52
Required/As Needed	As needed
Onsite/Remote	Onsite
Security Level	Provisioning or higher

Note

SFPs and XFPs are hot-swappable input/output devices that plug into a TXP, MXP, or line card port to link the port with the fiber-optic network. For more information, refer “Hardware Specifications” chapter in the *Cisco ONS 15454 DWDM Reference Manual*, or the *Installing GBIC, SFP and XFP Optics Modules in Cisco ONS 15454, 15454 SDH, 15327, 15600, and 15310-CL Platforms* document available “Cisco ONS 15454 SONET and DWDM Components Installation” section in the Cisco ONS 15454 documentation website on www.cisco.com.

Note

If you install an ONS-XC-10G-L2 XFP in a compatible transponder card (TXP_MR_10E, TXP_MR_10E_C, or TXP_MR_10E_L), you must have the transponder installed only in one of the high-speed slots (6, 7, 12, or 13)

Note

SFPs and XFPs are generically called PPMs in CTC. After installing multirate SFPs or XFPs, multirate PPMs must be provisioned in CTC. To complete the provisioning of the pluggable port, complete the “[DLP-G277 Provision a Multirate PPM](#)” task on page 5-6.

Step 1 Verify that the SFP or XFP is correct for your network and TXP or MXP card (see the “Card Reference” chapter in the *Cisco ONS 15454 DWDM Reference Manual*). Check that you are installing compatible SFPs or XFPs, for example, SX to SX or LX/LH to LX/LH.

Step 2 Install the SFP or XFP:

- For a mylar tab SFP or XFP: Slide the SFP or XFP into the slot.
- For an actuator/button SFP or XFP: Slide the SFP or XFP all the way into the slot until you hear a click.
- For a bail clasp SFP or XFP: Latch (flip upwards) the bail clasp before inserting the SFP or XFP into the slot and then slide it into the slot.



Note SFP and XFPs are keyed to prevent incorrect installation.

Step 3 Do not remove the protective caps from the SFP or XFP until you are ready to attach the network fiber-optic cable.

Step 4 Return to your originating procedure (NTP).

DLP-G273 Preprovision an SFP or XFP Slot

Purpose	This procedure preprovisions SFPs and XFPs, which connect fiber to TXP and MXP cards. SFPs and XFPs are referred to as pluggable port modules (PPMs) in CTC.
Tools/Equipment	None
Prerequisite Procedures	DLP-G46 Log into CTC, page 2-27
Required/As Needed	As needed
Onsite/Remote	Onsite or remote
Security Level	Provisioning or higher



Note

SFPs and XFPs are generically called PPMs in CTC. After installing multirate SFPs or XFPs, multirate PPMs must be provisioned in CTC. To complete the provisioning of the pluggable port, complete the “[DLP-G277 Provision a Multirate PPM](#)” task on page 5-6.

-
- Step 1** In node view (single-shelf mode) or shelf view (multishelf mode), double-click the TXP or MXP card where you want to provision PPM settings.
 - Step 2** Click the **Provisioning > Pluggable Port Modules** tabs.
 - Step 3** In the Pluggable Port Modules area, click **Create**. The Create PPM dialog box appears.
 - Step 4** In the Create PPM dialog box, complete the following:
 - PPM—Choose the slot number where the SFP or XFP is installed from the drop-down list.
 - PPM Type—Choose the number of ports supported by your SFP or XFP from the drop-down list. The drop-down list displays the number of PPMs that are available for provisioning. If only one port is supported, **PPM (1 port)** is the only option.
 - Step 5** Click **OK**. The newly created port appears in the Pluggable Port Modules pane. The row in the Pluggable Port Modules pane turns light blue. The Actual Equipment Type column remains blank until the actual SFP or XFP is installed. After the SFP or XFP is installed, the row in the pane turns white and the Actual Equipment Type column shows the equipment name.
 - Step 6** Verify that the PPM appears in the list in the Pluggable Port Modules pane. If it does not, repeat Steps 3 through 5.
 - Step 7** Repeat the task to provision a second PPM, if needed. If not, continue with [Step 8](#).
 - Step 8** Click **OK**.
 - Step 9** Return to your originating procedure (NTP).
-

DLP-G64 Remove an SFP or XFP

Purpose	This task removes SFPs and XFPs from TXP and MXP cards.
Tools/Equipment	None
Prerequisite Procedures	NTP-G32 Install the Transponder and Muxponder Cards, page 3-52
Required/As Needed	As needed
Onsite/Remote	Onsite
Security Level	Provisioning or higher



Note

This task removes the SFP or XFP hardware. To delete the provisioning for an SFP or XFP, see the [“DLP-G280 Delete a PPM” procedure on page 5-13](#).

-
- Step 1** If a fiber is connected, disconnect the network fiber cable from the SFP or XFP LC-type connector.
- Step 2** Release the SFP or XFP from the slot by performing one of the following actions (depending which latch is on the SFP or XFP):
- For a mylar tab SFP or XFP: Pull out the mylar tab.
 - For an actuator/button SFP or XFP: Press the actuator/button.
 - For a bail clasp SFP or XFP: Unlatch the bail clasp and swing it downward.
- Step 3** Slide the SFP or XFP out of the slot.
- Step 4** Return to your originating procedure (NTP).
-

NTP-G123 Install the Filler Cards

Purpose	This procedure explains how to install the filler cards (blank faceplates) in any unused traffic or AIC-I card slots (Slots 1 through 6, 9, and 11 through 17). The filler card aids in maintaining proper air flow and EMI requirements and is detected by CTC in Software Release 6.0 and higher.
Tools/Equipment	Filler cards (Cisco P/N 15454-FILLER)
Prerequisite Procedures	NTP-G30 Install the DWDM Cards, page 3-47 NTP-G31 Install the DWDM Dispersion Compensating Units, page 3-51 NTP-G32 Install the Transponder and Muxponder Cards, page 3-52
Required/As Needed	As needed
Onsite/Remote	Onsite
Security Level	None



Warning

Blank faceplates (filler panels) serve three important functions: they prevent exposure to hazardous voltages and currents inside the chassis; they contain electromagnetic interference (EMI) that might disrupt other equipment; and they direct the flow of cooling air through the chassis. Do not operate the system unless all cards and faceplates are in place. Statement 156

**Caution**

Always use the supplied electrostatic discharge (ESD) wristband when working with a powered ONS 15454. Plug the wristband cable into the ESD jack located on the lower right outside edge of the shelf assembly and ensure the shelf assembly is properly grounded.

-
- Step 1** Open the card ejectors.
- Step 2** Slide the card along the guide rails into the correct slot.
- Step 3** Close the ejectors.
- Step 4** Repeat for any remaining unused card slots.
- Stop. You have completed this procedure.**
-

NTP-G34 Install Fiber-Optic Cables on DWDM Cards and DCUs

Purpose	This procedure attaches fiber-optic cables on the DWDM cards and dispersion compensating units (DCUs).
Tools/Equipment	Fiber-optic cables Cisco MetroPlanner Internal Connections Report
Prerequisite Procedures	NTP-G30 Install the DWDM Cards, page 3-47 NTP-G31 Install the DWDM Dispersion Compensating Units, page 3-51 (as applicable) NTP-G139 Verify Cisco MetroPlanner Reports and Files, page 3-3
Required/As Needed	As needed
Onsite/Remote	Onsite
Security Level	None

**Warning**

Class I (CDRH) and Class 1M (IEC) laser products. Statement 1055

**Note**

For US installations, complies with the US Federal Drug Administration Code of Federal Regulations Title 21, Sections 1040.10 and 1040.11, except for deviations pursuant to Laser Notice No. 50, dated July 26, 2001.

**Note**

In this procedure, you will generally connect fibers in an east-to-west or west-to-east pattern only. “West” refers to cards and ports in Slots 1 through 8. “East” refers to cards and ports installed in Slots 10 through 17.

**Note**

You will install fiber-optic cables on TXP and MXP cards later in the chapter during the “[NTP-G140 Install Fiber-Optic Cables Between Terminal, Hub, or ROADM Node DWDM Cards and TXP/MXP Cards](#)” procedure on page 3-64.

- Step 1** Refer to the “[DLP-G349 Use the Cisco MetroPlanner Internal Connections Report](#)” task on page 3-61 to complete the remainder of this procedure.
- Step 2** Verify that fibers are available to complete the connections shown in the Cisco MetroPlanner Internal Connections report:
- Count the number of connections listed in the Internal Connections and verify that you have the same number of fibers.
 - Measure the distance between Position 1 and Position 2 for each connection, then verify that the fiber lengths will fit each one.
- Step 3** Complete the “[NTP-G115 Clean Fiber Connectors](#)” procedure on page 13-25 for all fiber connections, even new fiber. Dust particles can degrade performance. Put caps on any fiber connectors that are not used.
- Step 4** On the front of the fiber-storage tray (usually installed below the node you are fiber-ing), push the tabs on the left and right sides inward to release the lock on the tray.
- Step 5** Pull the fiber-storage tray away from the shelf until it is fully opened.
- Step 6** Open the fold-down door that at the bottom of the shelf assembly to expose the cable-routing channel ([Figure 3-10](#)).

Figure 3-10 Managing Cables on the Front Panel

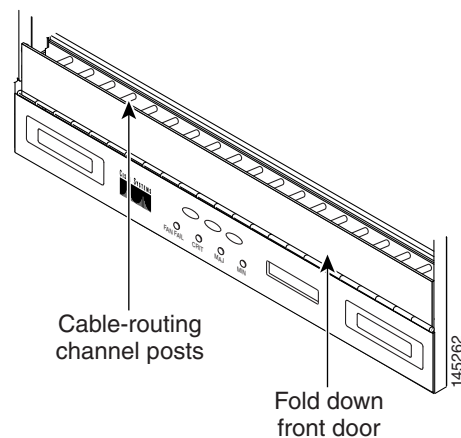

- Step 7** Using one end of the fiber cable into the desired RX port.
- Step 8** Route the fiber cable on the card faceplate through the fiber clip on the faceplate, if provided. (Fiber clips are factory-attached to the faceplates of 32MUX-O, 32DMX, 32DMX-O, OSCM, OSC-CSM, OPT-PRE, OPT-BST, OPT-BST-E, OPT-BST-L, OPT-AMP-L cards.)
- Step 9** Route the fiber cable through the cable-routing channel and cutout on the appropriate side of the shelf assembly, as necessary.
- Step 10** As needed, route slack fiber-optic cable around the round cable retainers in the fiber-storage tray ([Figure 3-11](#)).

Figure 3-11 Fiber-Storage Tray

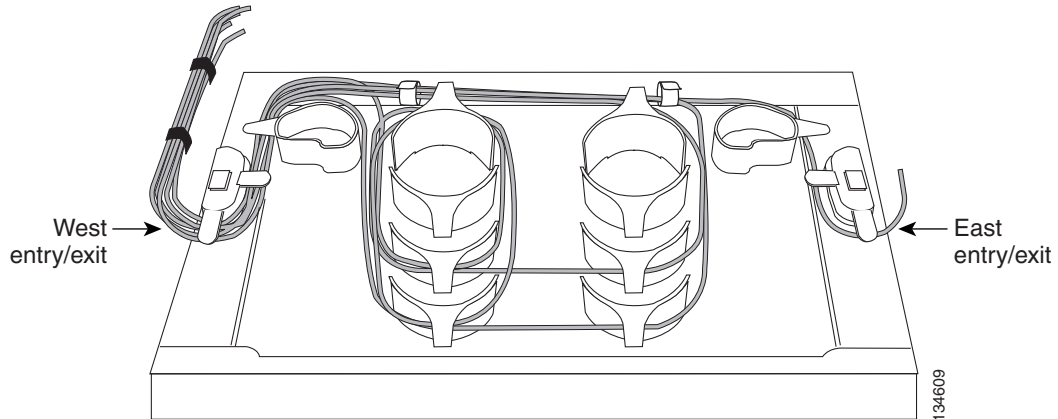
**Caution**

When you close the fiber-storage tray, the cables must not be pinched, and the cable bend radius must be equal to or greater than the minimum radius that is recommended in your site specifications. As you route each cable through the fiber-storage tray, make sure that adequate cable slack remains.

Step 11 Route the fiber cable out either side of the fiber-storage tray as necessary.

Step 12 Plug the other end of the cable into the desired TX port.

**Note**

Cards display an SF LED after the optical service channel (OSC) terminations are created (see the “[NTP-G38 Provision OSC Terminations](#)” procedure on page 3-87) and transmit and receive fibers are not connected correctly. For example, an RX port is connected to another RX port or a TX port is connected to another TX port.

Step 13 Repeat Steps 4 through 12 until you have connected the intra-shelf fibers according to the Cisco MetroPlanner Internal Connections report.

Step 14 To close the fiber-storage tray, push the tray back toward the rack until it locks into place.

Stop. You have completed this procedure.

DLP-G349 Use the Cisco MetroPlanner Internal Connections Report

Purpose	This task describes how to use the Cisco MetroPlanner Internal Connections report to install cables on the DWDM cards.
Tools/Equipment	None
Prerequisite Procedures	NTP-G139 Verify Cisco MetroPlanner Reports and Files, page 3-3
Required/As Needed	As needed
Onsite/Remote	Onsite
Security Level	Provisioning or higher

Step 1 Display the Cisco MetroPlanner Internal Connections report for the node that you are provisioning. The Internal Connections report is presented in two views, a patchcord installation view and a software provisioning view. [Figure 3-12 on page 3-62](#) shows an example patchcord installation view, and [Figure 3-13 on page 3-63](#) shows an example of a software provisioning view.

The table identifies the patchcords that you must cable by their endpoints. Position 1 identifies the fiber start point; Position 2 indicates the fiber endpoint. The patchcord endpoints are identified by site, slot, and port. Information provided by the Internal Connections report includes:

- **Name**—Displays the name of the site. On the software provisioning view, this column indicates whether you must create the connection manually in CTC. A Yes appearing in this column means that you must create the connection manually.
- **Position-1**—The cable origination in the format is Rack.Shelf.Port. For example, Rack#1.Main Shelf.02 refers to Slot 2 in the main (DWDM) shelf of Rack 1. Refer to the Cisco MetroPlanner Site Dialog for rack and shelf names and locations.
- **Unit-1**—The ONS 15454 DWDM card (unit) that is installed in the Position-1 slot. This is where the patchcord originates.
- **Port#-1**—The port identifier shown in the CTC for the first Position-1 connection.
- **Port ID-1**—(Software provisioning view only) The port identifier shown in TL1 for the Position-1 connection.
- **Port Label-1**—The name of the physical port printed on the card's front panel and shown in CTC card view for the Position-1 connection.
- **Attenuator**—If attenuation is required, the product ID (PID) of the bulk fixed attenuator is shown. "Att-Lpbk-4dB" indicates that the DC TX and DC RX ports on an OPT-PRE card are to be connected with an attenuated loopback that is shipped with the OPT-PRE card. This parameter also indicates when an internal attenuator must be placed between the OPT-PRE DC-TX and DC-RX ports on the when a DCU is equipped.



Note If the Attenuator field is blank, no attenuation is needed.

- **Position-2**—The cable termination in the format is Rack.Shelf.Port. For example, Rack#1.Main Shelf.02 refers to Slot 2 in the main shelf of Rack 1. Refer to the Cisco MetroPlanner Site Dialog window for rack and shelf names and locations.
- **Unit-2**—The ONS 15454 DWDM card that is installed in the Position-2 slot. This is where the cabling terminates.
- **Port #2**—The port identifier shown in CTC for the first Position-2 connection.

- Port ID-2—(Software provisioning view only) The port identifier shown in TL1 for the Position-2 connection.
- Port Label-2—The name of the physical port printed on the card's front panel and shown in CTC card view for the Position-2 connection.
- P/F—Indicates whether you must create the connection manually in CTC. A Yes appearing in this column means that you must create the connection manually.

**Caution**

Failure to create the required manual connections will prevent the node from turning up properly.

Figure 3-12 Cisco MetroPlanner Internal Connections Report - Patchcord Installation View

Name	Position	Unit	Port label	Attenuator	Position
Site1					
Cable	Rack 0.ShelfAnsi 0.Slot 2	AD-2C-58.1	EXP TX		Rack 0.ShelfAnsi 0.Slot 16
Cable	Rack 0.ShelfAnsi 0.Slot 16	AD-1C-58.1	EXP TX		Rack 0.ShelfAnsi 0.Slot 2
Cable	Rack 0.ShelfAnsi 0.Slot 2	AD-2C-58.1	AD_TX0	Attenuator	card Pos ?
Cable	Rack 0.ShelfAnsi 0.Slot 15	TXP_MR_10E_C	DWDM-TX		Rack 0.ShelfAnsi 0.Slot 2
Cable	Rack 0.ShelfAnsi 0.Slot 2	AD-2C-58.1	AD_TX1	Attenuator	card Pos ?
Cable	Rack 0.ShelfAnsi 0.Slot 14	MVP_MR_10DME_C	DWDM-TX		Rack 0.ShelfAnsi 0.Slot 2
Cable	Rack 0.ShelfAnsi 0.Slot 16	AD-1C-58.1	AD_TX0	Attenuator	card Pos ?
Cable	Rack 0.ShelfAnsi 0.Slot 13	MVP_MR_2_5G-58.1	DWDM-TX		Rack 0.ShelfAnsi 0.Slot 16
Cable	Rack 0.ShelfAnsi 0.Slot 1	OSC-CSM	COM TX		Rack 0.ShelfAnsi 0.Slot 2
Cable	Rack 0.ShelfAnsi 0.Slot 2	AD-2C-58.1	COM TX		Rack 0.ShelfAnsi 0.Slot 1
Cable	Rack 0.ShelfAnsi 0.Slot 17	OSC-CSM	COM TX		Rack 0.ShelfAnsi 0.Slot 16
Cable	Rack 0.ShelfAnsi 0.Slot 16	AD-1C-58.1	COM TX		Rack 0.ShelfAnsi 0.Slot 17
Site2					
Cable	Rack 0.ShelfAnsi 0.Slot 2	AD-1C-58.1	EXP TX		Rack 0.ShelfAnsi 0.Slot 16
Cable	Rack 0.ShelfAnsi 0.Slot 16	AD-1C-58.1	EXP TX		Rack 0.ShelfAnsi 0.Slot 2
Cable	Rack 0.ShelfAnsi 0.Slot 2	AD-1C-58.1	AD_TX0	Attenuator	card Pos ?
Cable	Rack 0.ShelfAnsi 0.Slot 15	MVP_MR_2_5G-58.1	DWDM-TX		Rack 0.ShelfAnsi 0.Slot 2
Cable	Rack 0.ShelfAnsi 0.Slot 16	AD-1C-58.1	AD_TX0	Attenuator	card Pos ?
Cable	Rack 0.ShelfAnsi 0.Slot 14	TXP_MR_10E_C	DWDM-TX		Rack 0.ShelfAnsi 0.Slot 16
Cable	Rack 0.ShelfAnsi 0.Slot 1	OSC-CSM	COM TX		Rack 0.ShelfAnsi 0.Slot 2
Cable	Rack 0.ShelfAnsi 0.Slot 2	AD-1C-58.1	COM TX		Rack 0.ShelfAnsi 0.Slot 1
Cable	Rack 0.ShelfAnsi 0.Slot 17	OSC-CSM	COM TX		Rack 0.ShelfAnsi 0.Slot 16
Cable	Rack 0.ShelfAnsi 0.Slot 16	AD-1C-58.1	COM TX		Rack 0.ShelfAnsi 0.Slot 17
Site3					

151591

Figure 3-13 Cisco MetroPlanner Internal Connections Report - SW Provisioning View

The screenshot shows the Cisco MetroPlanner Internal Connections Report in the SW Provisioning View. The interface includes a tree view on the left, a main table of connections, and a bottom status bar. The table lists connections for Site1 and Site2, with columns for Name, Position, Unit, Port Num, Port ID, Port label, and F. The connections are categorized by 'Manually Set: Yes' and 'Manually Set: No'.

Name	Position	Unit	Port Num	Port ID	Port label	F
Site1						
Manually Set: Yes						
Manually Set: No						
Cable	Rack 0.ShelfAnsi 0.Slot 2	AD-2C-S8.1	EXP TX	Rack 0.Sh
Cable	Rack 0.ShelfAnsi 0.Slot 16	AD-1C-S8.1	EXP TX	Rack 0.SF
Cable	Rack 0.ShelfAnsi 0.Slot 2	AD-2C-S8.1	AD_TX0	ca
Cable	Rack 0.ShelfAnsi 0.Slot 15	TXP_MR_10E_C	2	CHAN-14-2	DWDM-TX	Rack 0.SF
Cable	Rack 0.ShelfAnsi 0.Slot 2	AD-2C-S8.1	AD_TX0	ca
Cable	Rack 0.ShelfAnsi 0.Slot 14	MXP_MR_100ME_C	9	CHAN-13-9	DWDM-TX	Rack 0.SF
Cable	Rack 0.ShelfAnsi 0.Slot 16	AD-1C-S8.1	AD_TX0	ca
Cable	Rack 0.ShelfAnsi 0.Slot 13	MXP_MR_2.5G-S8.1	9	CHAN-12-9	DWDM-TX	Rack 0.Sh
Cable	Rack 0.ShelfAnsi 0.Slot 1	OSC-CSM	COM TX	Rack 0.SF
Cable	Rack 0.ShelfAnsi 0.Slot 2	AD-2C-S8.1	COM TX	Rack 0.SF
Cable	Rack 0.ShelfAnsi 0.Slot 17	OSC-CSM	COM TX	Rack 0.Sh
Cable	Rack 0.ShelfAnsi 0.Slot 16	AD-1C-S8.1	COM TX	Rack 0.Sh
Manually Set: No/Re...						
Site2						
Manually Set: Yes						
Manually Set: No						
Cable	Rack 0.ShelfAnsi 0.Slot 2	AD-1C-S8.1	EXP TX	Rack 0.Sh
Cable	Rack 0.ShelfAnsi 0.Slot 16	AD-1C-S8.1	EXP TX	Rack 0.SF
Cable	Rack 0.ShelfAnsi 0.Slot 2	AD-1C-S8.1	AD_TX0	ca
Cable	Rack 0.ShelfAnsi 0.Slot 15	MXP_MR_2.5G-S8.1	9	CHAN-14-9	DWDM-TX	Rack 0.SF
Cable	Rack 0.ShelfAnsi 0.Slot 16	AD-1C-S8.1	AD_TX0	ca
Cable	Rack 0.ShelfAnsi 0.Slot 14	TXP_MR_10E_C	2	CHAN-13-2	DWDM-TX	Rack 0.Sh
Cable	Rack 0.ShelfAnsi 0.Slot 1	OSC-CSM	COM TX	Rack 0.SF

Step 2 Return to your originating procedure (NTP).

NTP-G140 Install Fiber-Optic Cables Between Terminal, Hub, or ROADM Node DWDM Cards and TXP/MXP Cards

Purpose	This procedure routes fiber-optic cables from 32MUX-O, 32WSS, 32DMX-O, and 32DMX cards in a terminal, hub, or ROADM node to the patch panel, and from the patch panel to TXP/MXP cards.
Tools/Equipment	<p>The following node types require the listed equipment. The cards and patch panels should already be installed before you begin this procedure.</p> <p>Terminal node:</p> <ul style="list-style-type: none"> • One 32DMX-O card • One 32MUX-O card • One standard patch-panel tray; or one deep patch-panel tray • If you are using a standard patch panel, you will also need eight MPO cables: fiber-optic cables, terminated on one end with one multifiber push-on (MPO) connector and on the other end with eight LC-type connectors <p>Hub node:</p> <ul style="list-style-type: none"> • Two 32DMX-O cards • Two 32MUX-O cards • Two standard or two deep patch-panel trays • If you are using standard patch panels, you will also need sixteen MPO cables: fiber-optic cables, terminated on one end with one MPO connector and on the other end with eight LC-type connectors <p>ROADM node:</p> <ul style="list-style-type: none"> • Two 32WSS cards • Two 32DMX cards • Two standard or two deep patch-panel trays • If you are using standard patch panels, you will also need sixteen MPO cables: fiber-optic cables, terminated on one end with one MPO connector and on the other end with eight LC-type connectors <p>Fiber-optic cables, terminated with a single LC-type connector on each end Cisco MetroPlanner Internal Connections Report</p>
Prerequisite Procedures	<p>DLP-G28 Install the Fiber Patch-Panel Tray, page 1-68</p> <p>DLP-G29 Install the Fiber-Storage Tray, page 1-68</p> <p>NTP-G34 Install Fiber-Optic Cables on DWDM Cards and DCUs, page 3-58</p> <p>DLP-G348 Use the Cisco MetroPlanner Shelf Layout Report, page 3-50</p>
Required/As Needed	As needed
Onsite/Remote	Onsite
Security Level	None

-
- Step 1** On the front of the patch-panel tray, push the tabs on the left and right sides inward to release the lock on the tray.
- Step 2** Pull the patch-panel tray away from the shelf until it is fully opened.
- Step 3** Depending on the type of patch-panel tray you are using:
- If you are using the standard patch-panel tray:
 - Complete the “[DLP-G315 Install Fiber-Optic Cables From the 32WSS/32DMX and 32MUX-O/32DMX-O Cards to the Standard Patch-Panel Tray](#)” task on page 3-66.
 - Complete the “[DLP-G316 Install Fiber-Optic Cables from TXP/MXP Cards to the Standard Patch-Panel Tray](#)” task on page 3-70.
 - If you are using the deep patch-panel tray:
 - Complete the “[DLP-G356 Install Fiber-Optic Cables from the 32WSS/32DMX and 32MUX-O/32DMX-O Cards to the Deep Patch-Panel Tray](#)” section on page 3-71.
 - Complete the “[DLP-G357 Install Fiber-Optic Cables from the TXP/MXP Cards to the Deep Patch-Panel Tray](#)” section on page 3-74.
- Step 4** To close the fiber-storage tray, push the tray back toward the rack until it locks into place.
- Stop. You have completed this procedure.**
-

DLP-G315 Install Fiber-Optic Cables From the 32WSS/32DMX and 32MUX-O/32DMX-O Cards to the Standard Patch-Panel Tray

Purpose	This task describes how to route fiber-optic cables from 32MUX-O, 32WSS, 32DMX-O, and 32DMX cards in a terminal, hub, or ROADM node to the standard patch panel.
Tools/Equipment	<p>The following node types require the following equipment. The cards and patch panels should already be installed before you begin this procedure.</p> <p>Terminal node:</p> <ul style="list-style-type: none"> • One 32DMX-O card • One 32MUX-O card • One standard patch-panel tray • Eight fiber-optic MPO cables: each MPO cable is terminated on one end with one multifiber push-on (MPO) connector and on the other end with eight LC-type connectors <p>Hub node:</p> <ul style="list-style-type: none"> • Two 32DMX-O cards • Two 32MUX-O cards • Two standard patch-panel trays • Sixteen fiber-optic MPO cables: each MPO cable is terminated on one end with one multifiber push-on (MPO) connector and on the other end with eight LC-type connectors <p>ROADM node:</p> <ul style="list-style-type: none"> • Two 32WSS cards • Two 32DMX cards • Two standard patch-panel trays • Sixteen fiber-optic MPO cables: each MPO cable is terminated on one end with one multifiber push-on (MPO) connector and on the other end with eight LC-type connectors
Prerequisite Procedures	NTP-G34 Install Fiber-Optic Cables on DWDM Cards and DCUs, page 3-58
Required/As Needed	As needed
Onsite/Remote	Onsite
Security Level	None



Note

For a ROADM or hub node, two patch panels will be used, one for the east side and one for the west. The east side 32WSS/32DMX card will connect to the east patch panel. The west side 32WSS/32DMX card will connect to the west patch panel.

- Step 1** Choose either the east or west side of the shelf to cable the 32MUX-O and 32DMX-O cards (or the 32WSS and 32DMX cards for an ROADM node).

- Step 2** On the patch panel, pull up firmly on the two latches and use them to slide the patch panel up until it snaps in place above the tray (Figure 3-14).

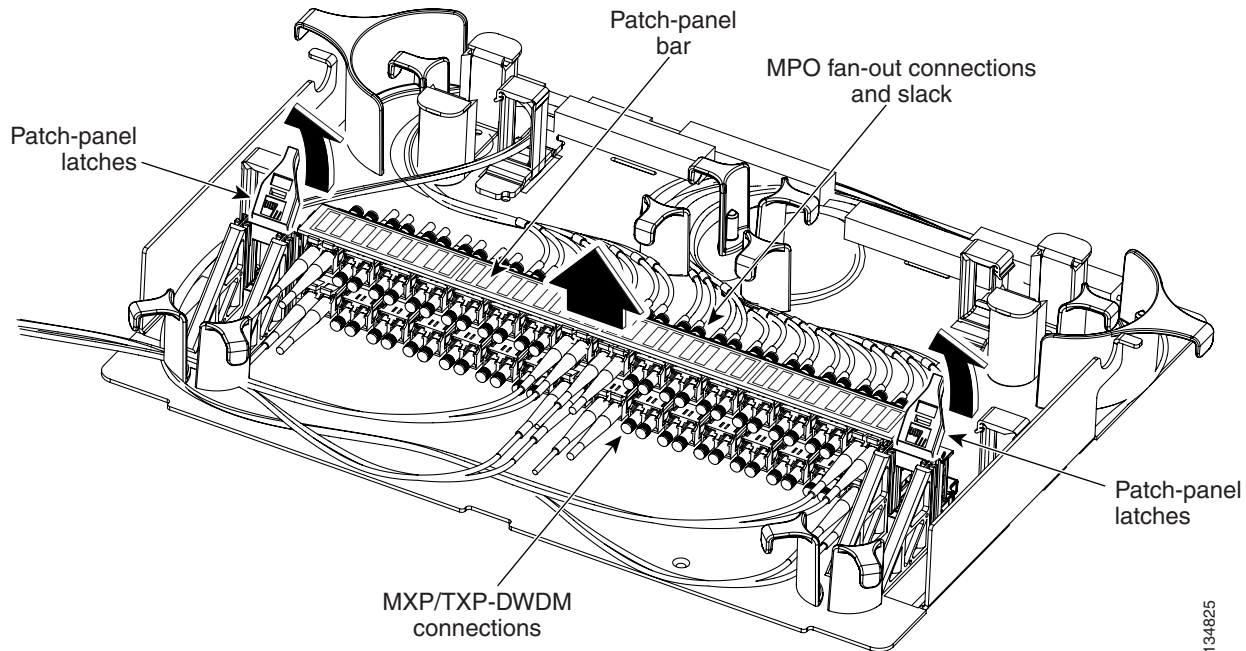
Figure 3-14 Using the Patch-Panel Latches to Slide the Patch Panel Away from the Tray



- Step 3** At the 32WSS or 32MUX-O card in the node, plug the MPO connector of an MPO cable (Figure 3-15) into the top Add RX (30.3–36.6) port of the card. If you are connecting a subsequent MPO cable, plug the MPO connector into the first vacant Add RX card port below the last MPO cable that was installed.

Figure 3-15 MPO Cable

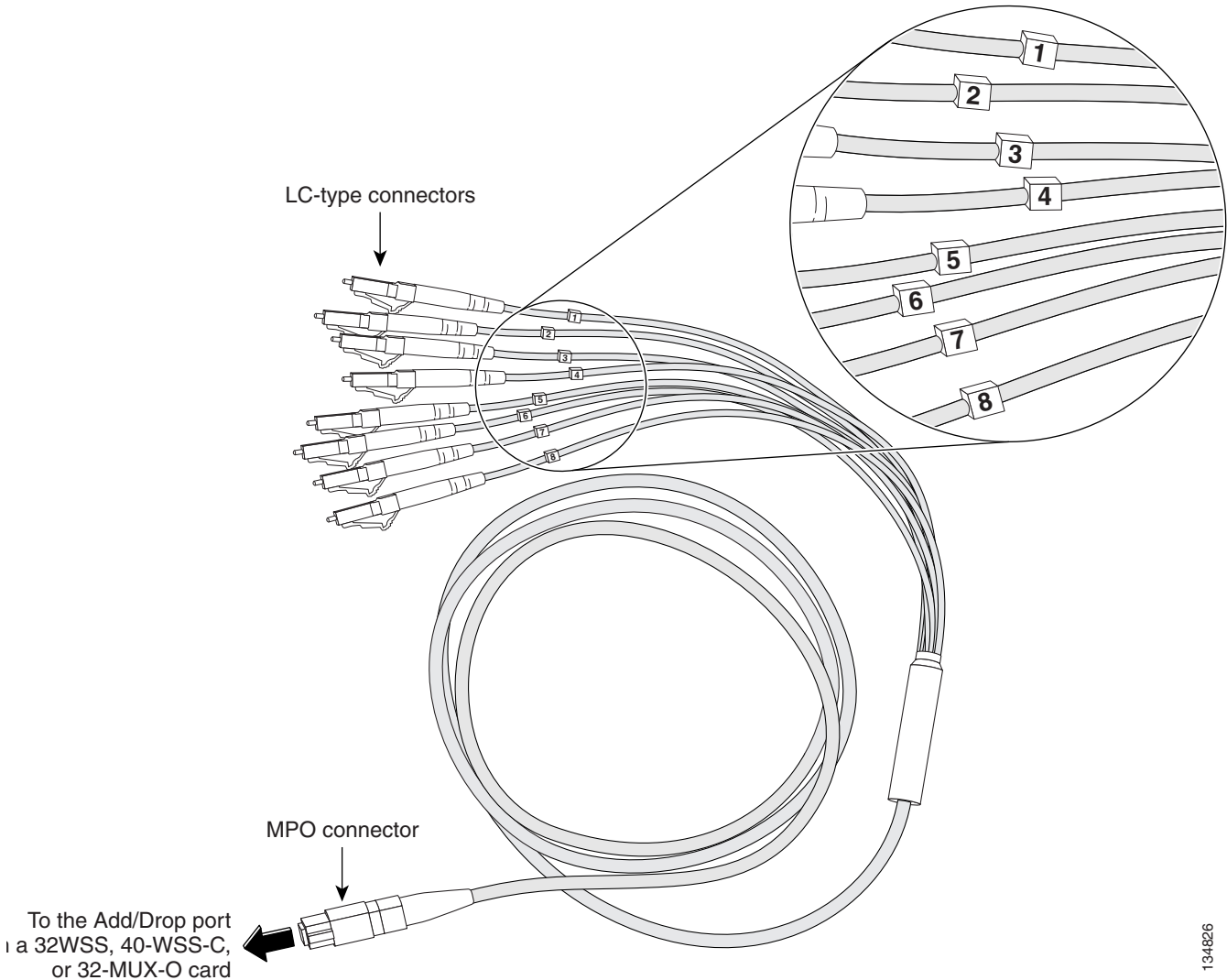

Step 4 Route the MPO cable slack through the patch-panel tray as necessary.



Caution

When you close the patch-panel tray, the cables must not be pinched, and the cable bend radius must be equal to or greater than the minimum radius that is recommended in your site specifications. As you route each cable through the patch-panel tray, make sure that adequate cable slack remains.

Step 5 While facing the front of the patch panel, at the rear side of the patch panel, plug the eight LC-connector fan-out cables on the MPO cable into their corresponding connectors on the bottom row of the patch panel. You should plug the fan-out cables from left to right (as you face the patch panel), following the numbers tagged (1 through 8) on the cables.

Figure 3-16 shows the patch-panel connectors from the rear of the patch-panel tray. Figure 3-17 shows the assigned wavelengths for each port on the patch panel, as indicated at the top of the patch-panel bar. The numbers on the patch-panel bar correspond to a wavelength on the ITU grid.

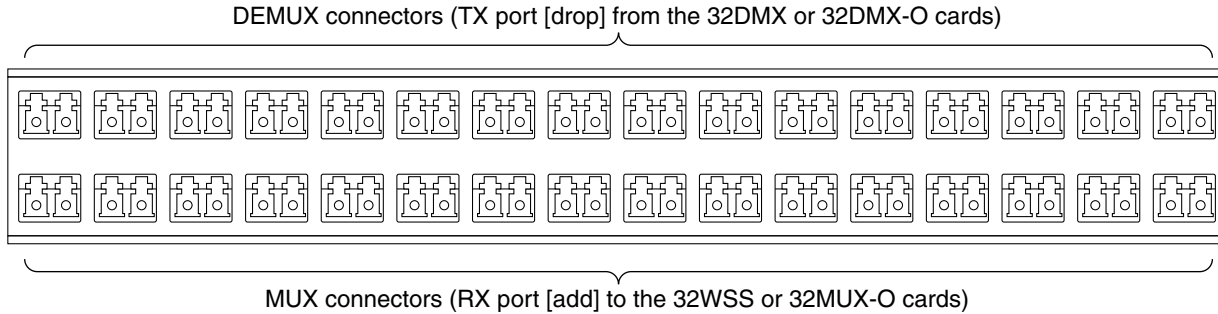
Figure 3-16 Rear View of the Patch Panel

134882

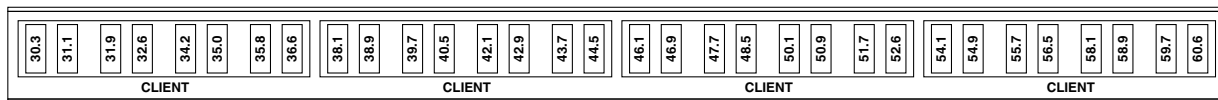
Figure 3-17 Top View of the Patch-Panel Bar

134824

- Step 6** As necessary, repeat Steps 3 through 5 for the remaining three Add RX ports on the 32WSS or MUX-O card, until all 32 LC connectors on the bottom row of the rear of the patch panel are connected.
- Step 7** At the adjacent 32DMX or DMX-O card in the same side of the shelf, plug the MPO connector of an MPO cable into the top Drop TX (30.3–36.6) port of the 32DMX or DMX-O card. If you are connecting a subsequent MPO cable, plug the MPO connector into the first vacant Drop TX card port below the last MPO cable that was installed.
- Step 8** Route the MPO cable slack through the patch-panel tray as necessary.

**Caution**

When you close the patch-panel tray, the cables must not be pinched, and the cable bend radius must be equal to or greater than the minimum radius that is recommended in your site specifications. As you route each cable through the patch-panel tray, make sure that adequate cable slack remains.

- Step 9** While facing the front of the patch panel, at the rear of the patch panel, plug the eight LC-connector fan-out cables on the MPO cable into their corresponding connectors on the top row of the patch panel. You should plug the fan-out cables from left to right (as you face the patch panel), following the numbers tagged (1 through 8) on the cables.
- Step 10** As necessary, repeat Steps 7 through 9 for the remaining three Drop TX ports on the 32DMX or DMX-O card, until all 32 LC connectors on the top row of the rear of the patch panel are connected.
- Step 11** For a hub or ROADM node, repeat Steps 2 through 10 to cable the other side of the shelf to the second patch panel. For a terminal node, go to Step 12.
- Step 12** Return to your originating procedure (NTP).

DLP-G316 Install Fiber-Optic Cables from TXP/MXP Cards to the Standard Patch-Panel Tray

Purpose	This task describes how to route fiber-optic cables from the patch panel to TXP and MXP cards.
Tools/Equipment	TXP or MXP card(s) Fiber-optic cable(s)
Prerequisite Procedures	NTP-G34 Install Fiber-Optic Cables on DWDM Cards and DCUs, page 3-58
Required/As Needed	As needed
Onsite/Remote	Onsite
Security Level	None

Step 1 At the appropriate TXP or MXP card, plug one end of a fiber-optic cable into the TX port of the DWDM adapter.

Step 2 As needed, route slack fiber-optic cable around the round cable retainers in the fiber-storage tray.



Caution

When you close the fiber-storage tray, the cables must not be pinched, and the cable bend radius must be equal to or greater than the minimum radius that is recommended in your site specifications. As you route each cable through the fiber-storage tray, make sure that adequate cable slack remains.

Step 3 On the DWDM (front) side of the patch panel, plug the other end of the cable into the connector on the bottom row that corresponds to the wavelength to which the TXP or MXP port is tuned. (See [Figure 3-17 on page 3-69](#) for a view of the wavelengths assigned to the patch-panel connectors).

[Figure 3-18](#) shows the patch-panel connectors from the front of the patch-panel tray.

Figure 3-18 Front View of the Patch Panel

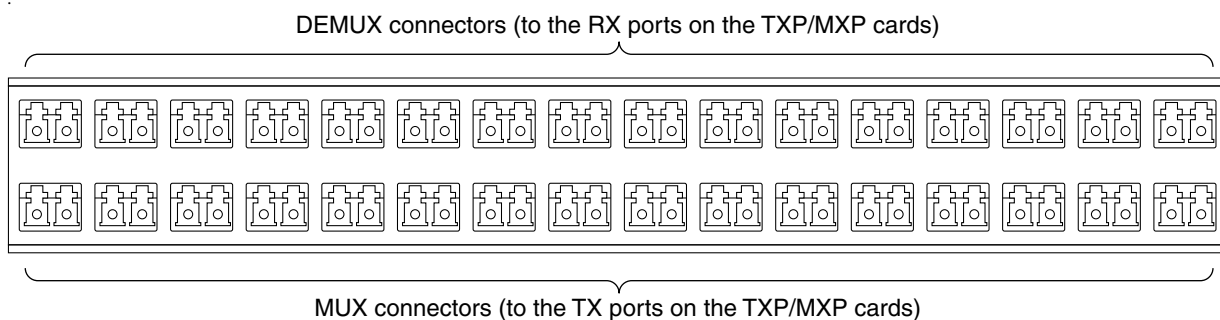

Step 4 Plug one end of a fiber-optic cable into the RX port of the DWDM adapter on that TXP/MXP card.

Step 5 On the DWDM (front) side of the patch panel, plug the other end of the cable into the connector on the top row that corresponds to the wavelength to which the TXP/MXP port is tuned.

Step 6 Repeat Steps 1 through 5 for all of the TXP/MXP cards that you want to connect to this patch panel.

Step 7 Return to your originating procedure (NTP).

DLP-G356 Install Fiber-Optic Cables from the 32WSS/32DMX and 32MUX-O/32DMX-O Cards to the Deep Patch-Panel Tray

Purpose	This task describes how to route fiber-optic cables from 32MUX-O, 32WSS, 32DMX-O, and 3DMX cards in a terminal, hub, or ROADM node to the deep patch-panel tray.
Tools/Equipment	<p>The following node types require the following equipment. The cards and patch panels should already be installed before you begin this procedure.</p> <p>Terminal node:</p> <ul style="list-style-type: none"> • One 32DMX-O card • One 32MUX-O card • One deep patch-panel tray, preinstalled with MPO cables (each MPO cable is terminated on one end with one multifiber push-on [MPO] connector and on the other end with eight LC-type connectors) <p>Hub node:</p> <ul style="list-style-type: none"> • Two 32DMX-O cards • Two 32MUX-O cards • Two deep patch-panel trays, preinstalled with MPO cables (each MPO cable is terminated on one end with one MPO connector and on the other end with eight LC-type connectors) <p>ROADM node:</p> <ul style="list-style-type: none"> • Two 32WSS cards • Two 32DMX cards • Two deep patch-panel trays, preinstalled with MPO cables (each MPO cable is terminated on one end with one multifiber push-on MPO connector and on the other end with eight LC-type connectors)
Prerequisite Procedures	NTP-G34 Install Fiber-Optic Cables on DWDM Cards and DCUs, page 3-58
Required/As Needed	As needed
Onsite/Remote	Onsite
Security Level	None



Note

For a ROADM or hub node, two patch panels will be used, one for the east side and one for the west. The east side 32WSS/32DMX card will connect to the east patch panel. The west side 32WSS/32DMX card will connect to the west patch panel. The MPO cables in the patch panel are preinstalled and routed out of the right side of the patch-panel tray.

-
- Step 1** Choose either the east or west side of the shelf to cable the 32MUX-O and 32DMX-O cards (or the 32WSS and 32DMX cards for an ROADM node).
- Step 2** On the patch panel, locate the MPO connectors ([Figure 3-15 on page 3-68](#)).
- Step 3** Route the preinstalled MPO cables out of the tray to the right or left ([Figure 3-19](#)).

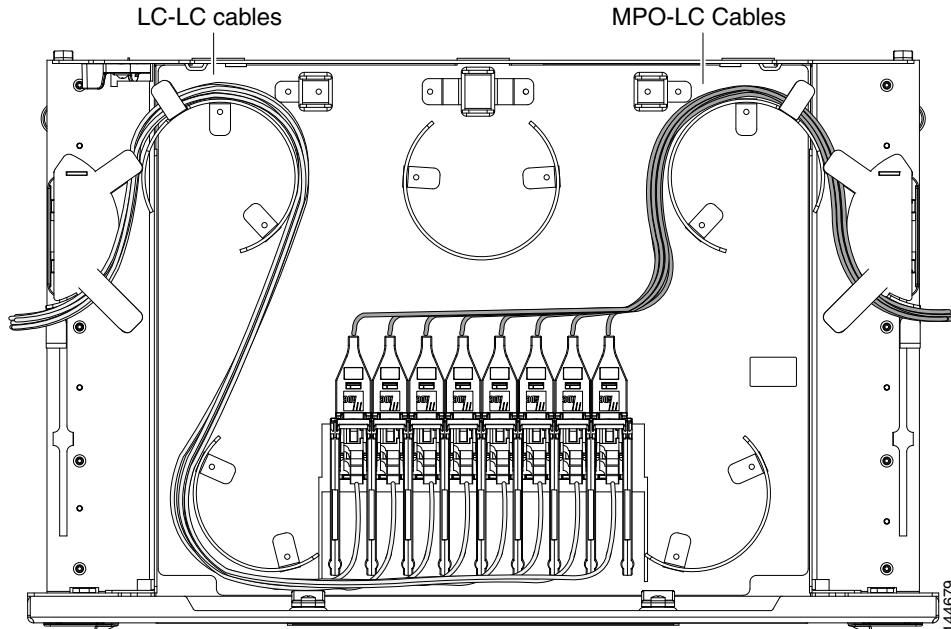
Figure 3-19 Deep Patch-Panel Tray

- Step 4** At the 32WSS or 32MUX-O card in the node, plug the MPO connector labeled “1 RX” on an MPO cable (Figure 3-15 on page 3-68) into the top Add RX (30.3–36.6) port of the card.
- Step 5** Plug the MPO connector labeled “2-RX” into the Add RX (38.1 - 44.5) port on the card.
- Step 6** Plug the MPO connector labeled “3-RX” into the Add RX (46.1 - 52.5) port on the card.
- Step 7** Plug the MPO connector labeled “4-RX” into the Add RX (54.1 - 60.6) port on the card.

**Caution**

When you close the patch-panel tray, the cables must not be pinched, and the cable bend radius must be equal to or greater than the minimum radius that is recommended in your site specifications. As you route each cable through the patch-panel tray, make sure that adequate cable slack remains.

Figure 3-20 shows the patch-panel ports and corresponding wavelengths.

Figure 3-20 Deep Patch-Panel Port Wavelengths

1	1532.6nm	1531.8nm	1531.1nm	1530.3nm				
	FX	FX	FX	FX				
2	1536.6nm	1535.8nm	1535.0nm	1534.2nm				
	FX	FX	FX	FX				
3	1540.5nm	1539.7nm	1538.9nm	1538.1nm				
	FX	FX	FX	FX				
4	1544.5nm	1543.7nm	1542.9nm	1542.1nm				
	FX	FX	FX	FX				
5	1548.5nm	1547.7nm	1546.9nm	1546.1nm				
	FX	FX	FX	FX				
6	1552.5nm	1551.7nm	1550.9nm	1550.1nm				
	FX	FX	FX	FX				
7	1556.5nm	1555.7nm	1554.9nm	1554.1nm				
	FX	FX	FX	FX				
8	1560.6nm	1559.7nm	1558.9nm	1558.1nm				
	FX	FX	FX	FX				
	1	2	3	4	5	6	7	8

144676

- Step 8** At the adjacent 32DMX or DMX-O card in the same side of the shelf, plug the MPO connector labeled “1 TX” on the MPO cable (Figure 3-15 on page 3-68) into the top Drop TX (30.3–36.6) port of the card (Figure 3-20).
- Step 9** Plug the MPO connector labeled “2-TX” into the Drop TX (38.1 - 44.5) port on the card.
- Step 10** Plug the MPO connector labeled “3-TX” into the Drop TX (46.1 - 52.5) port on the card.
- Step 11** Plug the MPO connector labeled “4-TX” into the Drop TX (54.1 - 60.6) port on the card.

**Caution**

When you close the patch-panel tray, the cables must not be pinched, and the cable bend radius must be equal to or greater than the minimum radius that is recommended in your site specifications. As you route each cable through the patch-panel tray, make sure that adequate cable slack remains.

- Step 12** For a hub or ROADM node, repeat Steps 4 through 11 to cable the other side of the shelf to the second patch panel. For a terminal node, go to Step 13.
- Step 13** Return to your originating procedure (NTP).

DLP-G357 Install Fiber-Optic Cables from the TXP/MXP Cards to the Deep Patch-Panel Tray

Purpose	This task describes how to route fiber-optic cables from the deep patch panel to TXP and MXP cards.
Tools/Equipment	TXP or MXP card(s) Fiber-optic cable(s) MetroPlanner Internal Connections Report
Prerequisite Procedures	NTP-G34 Install Fiber-Optic Cables on DWDM Cards and DCUs, page 3-58
Required/As Needed	As needed
Onsite/Remote	Onsite
Security Level	None

Step 1 Refer to the MetroPlanner Internal Connections Report to connect the TXP/MXP card to the proper (east or west) patch panel. MetroPlanner denotes the west side as Slots 1 to 6 and the east side as Slots 12 to 17. At the appropriate TXP or MXP card, plug one end of a fiber-optic cable into the TX port of the DWDM adapter.

Step 2 As needed, route slack fiber-optic cable around the round cable retainers in the fiber-storage tray.



Caution

When you close the fiber-storage tray, the cables must not be pinched, and the cable bend radius must be equal to or greater than the minimum radius that is recommended in your site specifications. As you route each cable through the fiber-storage tray, make sure that adequate cable slack remains.

Step 3 Plug the other end of the cable into the RX connector on the patch panel that corresponds to the wavelength to which the TXP or MXP port is tuned. (See [Figure 3-20 on page 3-73](#) for a view of the wavelengths assigned to the patch-panel connectors).

Step 4 Plug one end of a fiber-optic cable into the RX port of the DWDM adapter on that TXP/MXP card.

Step 5 Plug the other end of the cable into the TX connector on the patch panel that corresponds to the wavelength to which the TXP/MXP port is tuned.

Step 6 Repeat Steps 1 through 5 for all of the TXP/MXP cards that you want to connect to this patch panel.

Step 7 Return to your originating procedure (NTP).

NTP-G191 Install Fiber-Optic Cables on Passthrough ROADM Nodes

Purpose	This procedure routes fiber-optic cables from a 32WSS card in a ROADM node in one shelf to the corresponding 32WSS card in a ROADM node in another shelf. The purpose of this routing is to connect East and West intershelf ROADMs in a passthrough configuration.
Tools/Equipment	Each ROADM node requires the listed equipment. The cards and fiber-storage trays should already be installed before you begin this procedure. <ul style="list-style-type: none"> • One 32WSS card • One fiber-storage tray • Two 3-meter fiber-optic cables, each terminated with a single LC connector on each end. • Cisco MetroPlanner Internal Connections Report
Prerequisite Procedures	DLP-G29 Install the Fiber-Storage Tray, page 1-68 DLP-G348 Use the Cisco MetroPlanner Shelf Layout Report, page 3-50
Required/As Needed	As needed
Onsite/Remote	Onsite
Security Level	None

-
- Step 1** Choose either the East or West side of the first shelf to cable the 32WSS card for the first ROADM node.
- Step 2** Choose the corresponding West or East side of the second shelf to cable the 32WSS card for the second ROADM node.
- Step 3** On the front of the fiber-storage tray that will be used for routing the fiber-optic cable, push the tabs on the left and right sides inward to release the lock on the tray.
- Step 4** Pull the fiber-storage tray away from the shelf until it is fully opened.
- Step 5** Open the fold-down door located at the bottom of both shelf assemblies to expose the cable-routing channels for each ([Figure 3-21](#)).

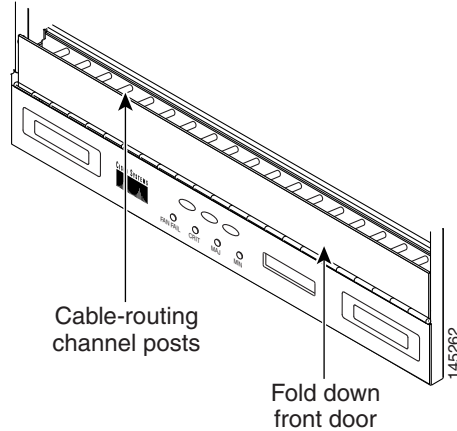
Figure 3-21 Managing Cables on the Front Panel

- Step 6** Plug one end of the first 3-meter fiber-optic cable into the EXP-TX connector on the first 32WSS card.
- Step 7** Route the fiber-optic cable through the shelf cable-routing channel and cutout on the appropriate side of the shelf assembly, as necessary.
- Step 8** Route the fiber-optic cable through the vertical fiber guide as needed to reach the entry to the fiber-storage tray.
- Step 9** Thread the cable into the fiber-storage tray at the appropriate side and around the first bend radius delimiter as shown (Figure 3-22).
- Step 10** As needed, route slack fiber-optic cable around the slack management cable retainers in the fiber-storage tray (Figure 3-22).

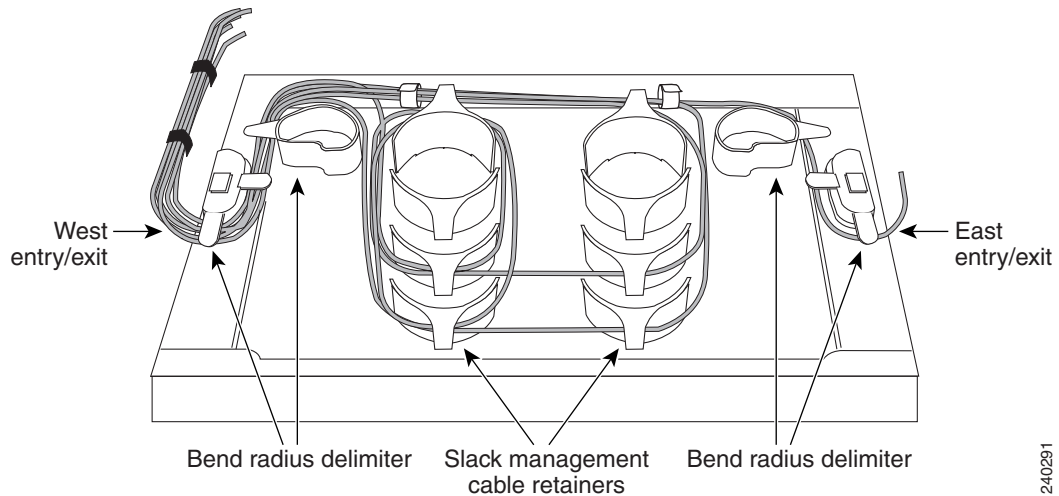
Figure 3-22 Fiber-Storage Tray**Caution**

When you close the fiber-storage tray, the cables must not be pinched, and the cable bend radius must be equal to or greater than the minimum radius that is recommended in your site specifications. As you route each cable through the fiber-storage tray, make sure that adequate cable slack remains.

- Step 11** Thread the fiber cable through the second bend delimiter and out the appropriate side of the fiber-storage tray as necessary.
- Step 12** Route the fiber-optic cable through the vertical fiber guide as needed to reach the second ROADM shelf where the second 32WSS is located.
- Step 13** Route the fiber-optic cable through the shelf cutout and through the shelf cable routing channel as needed.
- Step 14** Plug the end of the 3-meter fiber-optic cable into the EXP-RX port of the second 32WSS card.
- Step 15** Plug one end of the second 3-meter fiber-optic cable into the EXP-TX connector on the second 32WSS card.
- Step 16** Follow [Step 7](#) through [Step 14](#) to connect the EXP-TX connector of the second 32WSS card to the EXP-RX port of the first 32WSS card.
- Step 17** Close the fold-down doors located at the bottom of both shelf assemblies and slide the fiber-storage tray back into its normal locked position.
- Stop. You have completed this procedure.**

NTP-G141 Install Fiber-Optic Cables for Y-Cable Protection Modules

Purpose	This procedure installs and routes fiber-optic cables from the client signal to the Y-cable protection module (single mode or multimode), and from the Y-cable module to the transponder node. Using one Y-cable protection module, you can protect one client signal with two TXP or MXP cards, and two client signals with four TXP or MXP cards. You can use Y-cable protection modules that you have installed in a FleyLayer shelf, or Y-cable modules installed in a Y-cable module tray.
Tools/Equipment	Fiber-optic cables Cisco MetroPlanner Internal Connections Report
Prerequisite Procedures	DLP-G32 Install the Y-Cable Protection Modules in the FlexLayer Shelf, page 1-73 DLP-G377 Install the Y-Cable Protection Modules in the Y-Cable Module Tray, page 1-73
Required/As Needed	As needed
Onsite/Remote	Onsite
Security Level	None



Note

Refer to the “Shelf Assembly Hardware” chapter in the *Cisco ONS 15454 DWDM Reference Manual* for more information about Y-cable protection.

- Step 1** As needed, complete the “[DLP-G375 Install Fiber-Optic Cables on the Y-Cable Modules in the FlexLayer Shelf](#)” task on page 3-78.

Step 2 As needed, complete the “[DLP-G376 Install Fiber-Optic Cables on the Y-Cable Modules in the Y-Cable Module Tray](#)” task on page 3-79.

Stop. You have completed this procedure.

DLP-G375 Install Fiber-Optic Cables on the Y-Cable Modules in the FlexLayer Shelf

Purpose	This task installs fiber-optic cables from the TXP/MXP cards to the Y-cable modules installed in the FlexLayer shelves, and from the Y-cable modules to the client devices.
Tools/Equipment	Fiber-optic cables Cisco MetroPlanner Internal Connections Report
Prerequisite Procedures	DLP-G32 Install the Y-Cable Protection Modules in the FlexLayer Shelf , page 1-73 NTP-G32 Install the Transponder and Muxponder Cards , page 3-52
Required/As Needed	As needed
Onsite/Remote	Onsite
Security Level	None

Step 1 Referring to the Cisco MetroPlanner Internal Connections Report, install a fiber-optic cable between a TXP or MXP card and a Y-cable module.

If you want to protect one client signal, connect the fiber-optic cables according to either [Table 3-3](#) or [Table 3-4](#). To protect two client signals using a single Y-cable module, connect the cables according to both [Table 3-3](#) and [Table 3-4](#).

Table 3-3 Cable Connections for Y-Cable Protection of One Client Signal

From	To (Y-Cable Port Number)
Client 1 TX port	10
Client 1 RX port	5
TXP/MXP 1 TX port	1
TXP/MXP 1 RX port	2
TXP/MXP 2TX port	6
TXP/MXP 2RX port	7

Table 3-4 Cable Connections for Y-Cable Protection of a Second Client Signal

From	To (Y-Cable Port Number)
Client 2 TX port	12
Client 2 RX port	11
TXP/MXP 3 TX port	3

Table 3-4 Cable Connections for Y-Cable Protection of a Second Client Signal (continued)

From	To (Y-Cable Port Number)
TXP/MXP 3 RX port	4
TXP/MXP 4 TX port	8
TXP/MXP 4 RX port	9

Step 2 As needed, route slack fiber-optic cable around the round cable retainers in the fiber-storage tray as you install cables between the Y-cable module and the TXP or MXP cards (Figure 3-11 on page 3-60).

**Caution**

When you close the fiber-storage tray, the cables must not be pinched, and the cable bend radius must be equal to or greater than the minimum radius that is recommended in your site specifications. As you route each cable through the fiber-storage tray, make sure that adequate cable slack remains.

Step 3 Install a fiber-optic cable between the client device and the Y-cable module where you just installed a fiber-optic cable to the TXP/MXP card.

Step 4 Repeat Steps 1 through 3 for each Y-cable module you need to use for Y-cable protection.

Step 5 Return to your originating procedure (NTP).

DLP-G376 Install Fiber-Optic Cables on the Y-Cable Modules in the Y-Cable Module Tray

Purpose	This task installs fiber-optic cables from the TXP/MXP cards to the Y-cable modules installed in the Y-cable module tray, and from the Y-cable modules to the client devices.
Tools/Equipment	Fiber-optic cables (4-meter [13.12-foot]), single-mode or multimode as appropriate Cisco MetroPlanner Internal Connections Report
Prerequisite Procedures	DLP-G32 Install the Y-Cable Protection Modules in the FlexLayer Shelf, page 1-73 NTP-G32 Install the Transponder and Muxponder Cards, page 3-52
Required/As Needed	As needed
Onsite/Remote	Onsite
Security Level	None

Step 1 Open the drawer of the tray by pushing inward on the latches located at the left and right front of the tray.

Step 2 On each Y-cable module you will connect, use the tab to slide the module up so that it is fully extended and easily accessible in the tray.

Step 3 Referring to the Cisco MetroPlanner Internal Connections Report, install a 4-meter (13.12-foot) fiber-optic cable (single-mode or multimode, as appropriate) between a TXP or MXP card and the Y-cable module installed farthest to the left. Proceed according to the port label affixed to the front of the tray to identify the ports on each installed module (Figure 3-23).

Figure 3-23 Y-Cable Protection Port Label

Client TX	Client TX	Client TX	Client TX	Client TX	Client TX	Client TX	Client TX
Client RX	Client RX	Client RX	Client RX	Client RX	Client RX	Client RX	Client RX
TXP W TX	TXP W TX	TXP W TX	TXP W TX	TXP W TX	TXP W TX	TXP W TX	TXP W TX
TXP W RX	TXP W RX	TXP W RX	TXP W RX	TXP W RX	TXP W RX	TXP W RX	TXP W RX
TXP P TX	TXP P TX	TXP P TX	TXP P TX	TXP P TX	TXP P TX	TXP P TX	TXP P TX
TXP P RX	TXP P RX	TXP P RX	TXP P RX	TXP P RX	TXP P RX	TXP P RX	TXP P RX
#1	#2	#3	#4	#5	#6	#7	#8

144677

**Note**

You can use the label shown in [Figure 3-23](#) to take notes as to which wavelength/port you are connecting to each Y-cable module. “W” denotes the indicated Working port on the TXP or MXP card. “P” denotes the indicated Protect port on the TXP or MXP card.

**Note**

Protective covers are installed over the third and fourth ports on the Y-cable modules because they are not used.

As needed, route slack fiber-optic cable around the round cable retainers in the Y-cable module tray as you install cables between the Y-cable module and the TXP or MXP card ([Figure 3-24](#)).

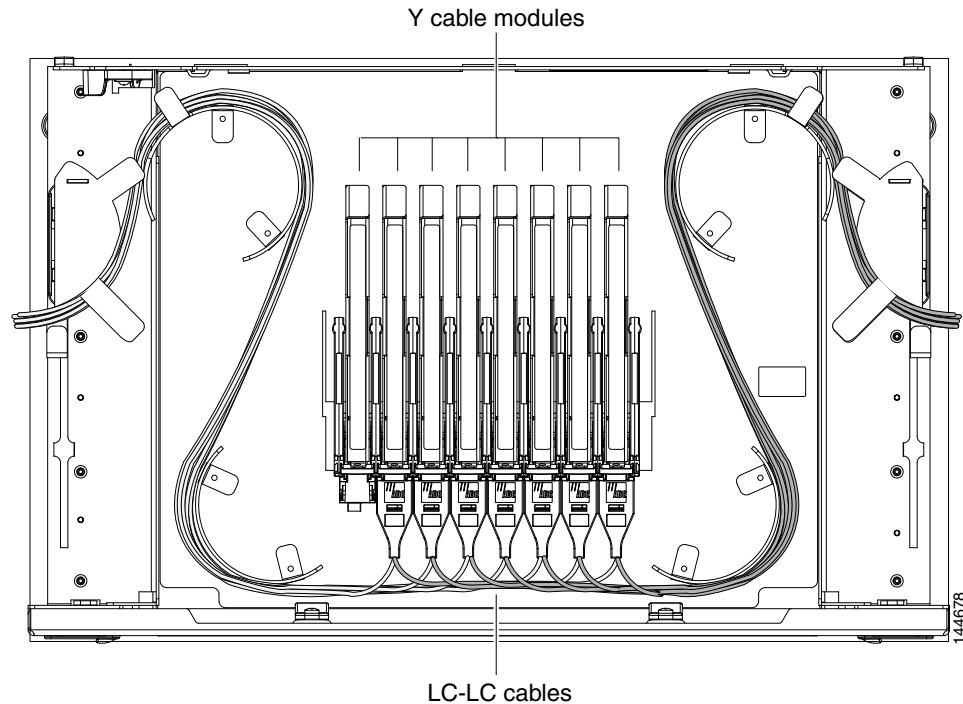
Figure 3-24 Y-Cable Protection Module Tray**Caution**

When you close the Y-cable module tray, the cables must not be pinched, and the cable bend radius must be equal to or greater than the minimum radius that is recommended in your site specifications. As you route each cable through the tray, make sure that adequate cable slack remains.

- Step 4** Referring to the Cisco MetroPlanner Internal Connections Report, install a fiber-optic cable of adequate length (single-mode or multimode, as appropriate) between the Y-cable module and the client signal that you want to protect.
- Step 5** As needed, route slack fiber-optic cable around the round cable retainers in the Y-cable module tray as you install cables between the Y-cable module and the TXP or MXP card.
- Step 6** Repeat Steps 2 through 5 for each Y-cable module you need to use for Y-cable protection.
- Step 7** To close the tray, unlock the drawer from the open position by depressing the red lock at the back left of the tray and push the tray closed.
- Step 8** Return to your originating procedure (NTP).

NTP-G152 Create and Verify Internal Patchcords

Purpose	This procedure creates the default internal patchcords, verifies the installed cards and calculates the connections that should be provisioned for them.
Tools/Equipment	Cisco MetroPlanner shelf layout Cisco MetroPlanner Internal Connections Report
Prerequisite Procedures	NTP-G22 Verify Common Card Installation, page 3-4 NTP-G139 Verify Cisco MetroPlanner Reports and Files, page 3-3
Required/As Needed	Required
Onsite/Remote	Onsite or remote
Security Level	Superuser

Step 1 Complete the “[DLP-G46 Log into CTC](#)” task on [page 2-27](#) at the node where you want to provision the DWDM cable connections. If you are already logged in, continue with [Step 2](#).

Step 2 In node view (single-shelf mode) or multishelf view (multishelf mode), click the **Provisioning > WDM-ANS > Internal Patchcords** tabs.

Step 3 Click **Default Patchcords**.

CTC verifies that the cards installed in the ONS 15454 shelf are compatible and will operate together as a valid DWDM node configuration. Furthermore, based on the cards installed or preprovisioned, CTC calculates the intra-shelf patchcords that are expected to be installed. If the cards are not compatible or are missing, for example, if an OPT-BST is installed but an OSCM card is not installed, the default patchcords function generates an error.



Note The Internal Patchcords tab does not show OPT-PRE DCU connections, span connections, or connections between the TXP/MXP cards and the DWDM cards.



Note The default patchcords calculation is not based on the Cisco MetroPlanner shelf layout or Internal Connections report. Calculations are based on the cards that are physically installed. If the Cisco MetroPlanner shelf layout calls for a ROADM node but hub node cards are installed, CTC calculates the internal patchcords based on the cards expected for a hub node.

Step 4 If no errors were generated, continue with [Step 5](#). If errors appear, verify that the cards installed in the shelf match the Cisco MetroPlanner shelf layout. If the wrong cards are installed or are missing, install the correct cards following the “[NTP-G30 Install the DWDM Cards](#)” procedure on [page 3-47](#).

Step 5 Verify that the connections in the Internal Patchcords tab match the connections in the Cisco MetroPlanner Internal Connections Report for the DWDM cards (see the “[DLP-G349 Use the Cisco MetroPlanner Internal Connections Report](#)” task on [page 3-61](#)). The CTC Connections tab will not show OPT-PRE DCUs, connections, span connections, or connections between TXP and MXP cards and the DWDM cards.

Step 6 Complete the “[DLP-G354 Create an Internal Patchcord Manually](#)” task on [page 3-83](#) for any connections that require manual provisioning. Connections that require manual creation appear under Manually Set: Yes in the Cisco MetroPlanner Internal Connections report. If you need to delete a connection, complete the “[DLP-G355 Delete an Internal Patchcord](#)” task on [page 3-86](#).



Note Although CTC calculates most DWDM connections automatically, some connections cannot be calculated because of the DWDM card type and position. You must create these connections manually. For example, connections related to optical bypass circuits must be manually provisioned.

Stop. You have completed this procedure.

DLP-G354 Create an Internal Patchcord Manually

Purpose	This task creates an internal patchcord manually when CTC is unable to calculate the internal patchcords automatically.
Tools/Equipment	None
Prerequisite Procedures	DLP-G46 Log into CTC, page 2-27
Required/As Needed	As needed
Onsite/Remote	Onsite or remote
Security Level	Superuser



Note Use only one management interface to complete the creation of internal patchcords. For example, do not begin the internal patchcord creation using the TL1 interface or CTP XML file and end the internal patchcord creation using CTC.

- Step 1** In node view (single-shelf mode) or multishelf view (multishelf mode), click the **Provisioning > WDM-ANS > Internal Patchcord** tabs.
- Step 2** Click **Create**.
- Step 3** In the Create Optical Link dialog box ([Figure 3-25](#)), complete the internal patchcord From fields:
- **ShelfID**—If the internal patchcord is being created on a multishelf node, choose the originating shelf ID. (This field is not available for single-shelf nodes.)
 - **Slot**—Choose the slot containing the card where the internal patchcord originates.
 - **Port**—Choose the originating port. If you are creating an internal patchcord between a TXP or MXP card and a DMX card, choose the DMX port that matches the wavelength of the TXP or MXP card. The DMX card wavelengths are shown in [Table 3-5](#).



Note To successfully create an Internal Patchcord between WSS/DMX channel port and TxP trunk port, the TxP must be chosen as "From" end point while WSS/DMX must be chosen as "To" end point.

Figure 3-25 Create Optical Link Dialog Box

The screenshot shows a dialog box titled "Create Optical Link". It is divided into two main sections: "From" and "To".

- From:**
 - ShelfId: 1
 - Slot: 5 32 DMX
 - Port: 1 (CHAN-TX)
- To:**
 - ShelfId: 2
 - Slot: 2 TXP_MR_2.5G
 - Port: 2 (Trunk)

At the bottom, there is a checked checkbox for "Bidirectional", and "OK" and "Cancel" buttons.

Table 3-5 Ports and Wavelengths for 32DMX, 32DMX-O, and 32DMX-L Cards

Port #	32DMX-O and 32DMX Wavelength (nm)	32DMX-L Wavelength (nm)	Port #	32DMX-O and 32DMX Wavelength (nm)	32DMX-L Wavelength (nm)
1	1530.33	1577.86	17	1546.12	1591.26
2	1531.12	1578.69	18	1546.92	1592.10
3	1531.90	1579.52	19	1547.72	1592.95
4	1532.68	1580.35	20	1548.51	1593.79
5	1534.25	1581.18	21	1550.12	1594.64
6	1535.04	1582.02	22	1550.92	1595.49
7	1535.82	1582.85	23	1551.72	1596.34
8	1536.61	1583.69	24	1552.52	1597.19
9	1538.19	1584.53	25	1554.13	1598.04
10	1538.98	1585.36	26	1554.94	1598.89
11	1539.77	1586.20	27	1555.75	1599.75
12	1540.56	1587.04	28	1556.55	1600.60
13	1542.14	1587.88	29	1558.17	1601.46
14	1542.94	1588.73	30	1558.98	1602.31
15	1543.73	1589.57	31	1559.79	1603.17
16	1544.53	1590.41	32	1560.61	1604.03

Step 4 In the Create Optical Link dialog box, complete the internal patchcord To fields:

- ShelfID—If the internal patchcord is being created on a multishelf node, choose the terminating shelf ID. (This field is not available for single-shelf nodes.)

- Slot—Choose the slot containing the card where the internal patchcord terminates.
- Port—Choose the terminating port.

Step 5 If the connection is unidirectional, uncheck the **bidirectional** check box.

Step 6 Click **OK**. The new patchcord(s) appear in the Internal Patchcords table. If bidirectional was selected, two patchcords will appear. However, the patchcord state is Uncommitted. [Figure 3-26](#) shows an example.

Figure 3-26 Internal Patchcords Table

The screenshot shows the Cisco Transport Controller interface for a node named 'Roadm3(90)'. The 'Internal Patchcords' tab is active, displaying a table of patchcords. The table has columns for 'From', 'To', and 'State'. One patchcord is highlighted in blue, and an arrow points to it with the label 'Uncommitted internal patchcord status'.

From	To	State
Shelf 1, Slot 1 (OPT-BST), Port 2 (COM-TX)	Shelf 1, Slot 2 (OPT-PRE), Port 1 (COM-RX)	Connected
Shelf 1, Slot 1 (OPT-BST), Port 4 (OSC-TX)	Shelf 1, Slot 8 (OSCM), Port 2 (OSC-RX)	Connected
Shelf 1, Slot 2 (OPT-PRE), Port 2 (COM-TX)	Shelf 1, Slot 3 (32 WSS), Port 66 (EXP-RX)	Connected
Shelf 1, Slot 3 (32 WSS), Port 65 (EXP-TX)	Shelf 1, Slot 14 (32 WSS), Port 66 (EXP-RX)	Connected
Shelf 1, Slot 3 (32 WSS), Port 67 (COM-TX)	Shelf 1, Slot 1 (OPT-BST), Port 1 (COM-RX)	Connected
Shelf 1, Slot 3 (32 WSS), Port 69 (DROP-TX)	Shelf 1, Slot 5 (32 DMX), Port 23 (COM-RX)	Connected
Shelf 1, Slot 3 (32 WSS), Port 69 (DROP-TX)	Shelf 2, Slot 3 (32 WSS), Port 1 (CHAN-RX) (Trunk)	Uncommitted
Shelf 1, Slot 8 (OSCM), Port 3 (OSC-TX)	Shelf 1, Slot 17 (OPT-BST), Port 3 (OSC-RX)	Connected
Shelf 1, Slot 14 (32 WSS), Port 65 (EXP-TX)	Shelf 1, Slot 17 (OPT-BST), Port 3 (OSC-RX)	Connected
Shelf 1, Slot 14 (32 WSS), Port 65 (EXP-TX)	Shelf 1, Slot 3 (32 WSS), Port 66 (EXP-RX)	Connected
Shelf 1, Slot 14 (32 WSS), Port 67 (COM-TX)	Shelf 1, Slot 17 (OPT-BST), Port 1 (COM-RX)	Connected
Shelf 1, Slot 14 (32 WSS), Port 69 (DROP-TX)	Shelf 1, Slot 13 (32 DMX), Port 33 (COM-RX)	Connected
Shelf 1, Slot 16 (OPT-PRE), Port 2 (COM-TX)	Shelf 1, Slot 14 (32 WSS), Port 68 (COM-RX)	Connected
Shelf 1, Slot 17 (OPT-BST), Port 2 (COM-TX)	Shelf 1, Slot 16 (OPT-PRE), Port 1 (COM-RX)	Connected
Shelf 1, Slot 17 (OPT-BST), Port 4 (OSC-TX)	Shelf 1, Slot 10 (OSCM), Port 2 (OSC-RX)	Connected
Shelf 2, Slot 15 (TRF_MR_10s), Port 2 (Trunk)	Shelf 1, Slot 3 (32 WSS), Port 1 (CHAN-RX)	Uncommitted

Step 7 Click the new patchcord(s) in the table. If two patchcords were created, click one patchcord, press the **Ctrl** key and click the next.

Step 8 Click **Commit**. The State column changes to Connected.

Step 9 If you need to create additional internal patchcords, repeat Steps 2 through 8 for each new patchcord. If not, continue with [Step 10](#).

Step 10 Return to your originating procedure (NTP).

DLP-G355 Delete an Internal Patchcord

Purpose	This task deletes an internal patchcord.
Tools/Equipment	None
Prerequisite Procedures	DLP-G46 Log into CTC, page 2-27
Required/As Needed	As needed
Onsite/Remote	Onsite or remote
Security Level	Superuser

-
- Step 1** In node view (single-shelf mode) or multishelf view (multishelf mode), click the **Provisioning > WDM-ANS > Internal Patchcord** tabs.
- Step 2** Click the connection you want to delete.
- Step 3** Click **Delete**, then click **Yes**.
- Step 4** Return to your originating procedure (NTP).
-

NTP-G37 Run Automatic Node Setup

Purpose	This procedure runs the CTC DWDM automatic node setup (ANS) function. ANS adjusts the values of the variable optical attenuators (VOAs) to equalize the per-channel power at the amplifier level.
Tools/Equipment	The Cisco MetroPlanner Installation Parameters file
Prerequisite Procedures	NTP-G152 Create and Verify Internal Patchcords, page 3-82 NTP-G143 Import the Cisco MetroPlanner NE Update Configuration File, page 3-40 NTP-G139 Verify Cisco MetroPlanner Reports and Files, page 3-3
Required/As Needed	Required
Onsite/Remote	Onsite or remote
Security Level	Superuser

-
- Step 1** Complete the “[DLP-G46 Log into CTC](#)” task on [page 2-27](#) at the node where you want to run ANS. If you are already logged in, continue with [Step 2](#).
- Step 2** Referring to the Cisco MetroPlanner Installation Parameters (see [Table 3-1 on page 3-3](#)), identify the parameters that have a Yes in the Manually Set column. If there are no parameters that have a Yes in the Manually Set column, continue with [Step 6](#).
- Step 3** In CTC, display the card where the parameter is to be manually provisioned in card view.
- Step 4** Enter the specified Calibration parameter from the Cisco MetroPlanner Installation Parameters table. Click **Apply**.
- Step 5** Repeat [Steps 2](#) through [4](#) for all parameters in the Cisco MetroPlanner Installation Parameters table that display Yes in the Manually Set field.
- Step 6** Change to node view (single-shelf mode) or multishelf view (multishelf mode).

- Step 7** Click the **Provisioning > WDM-ANS > Port Status** tabs.
- Step 8** Click **Launch ANS**.
- Step 9** In the Apply Launch ANS dialog box, click **Yes**.
- Step 10** In the Launch ANS confirmation dialog box, click **OK**.
- Step 11** Verify that one of the following statuses appears in the Link Status column for all ports:
- Success - Changed—The parameter setpoint was recalculated successfully.
 - Success - Unchanged—The parameter setpoint did not need recalculation.
 - Not Applicable—The parameter setpoint does not apply to this node type.

If one of the following statuses is shown, complete the provided instructions:

- Fail - Out of Range—The calculated setpoint is outside the expected range. Repeat the “[NTP-G152 Create and Verify Internal Patchcords](#)” procedure on page 3-82 to verify that all connections were provisioned correctly, paying attention to connections that require manual provisioning.



Note The Fail - Out of Range condition must be cleared before proceeding. Contact your next level of support if you are unable to clear this status.

- Fail - Port in IS State—The parameter could not be calculated because the port is in service. This status should normally not appear at this point in node turn-up. If it does, display the card in card view, change the port administrative state to OOS,DSL (ANSI) or Locked,disabled (ETSI), and repeat Steps 6 through 11.

Stop. You have completed this procedure.

NTP-G38 Provision OSC Terminations

Purpose	This procedure provisions the optical service channel (OSC) terminations. The OSC provides a bidirectional channel that connects all nodes within a DWDM ring. The OSC carries a supervisory data channel and synchronizes clocking at network nodes. The OSC also carries a user data channel.
Tools/Equipment	None
Prerequisite Procedures	NTP-G143 Import the Cisco MetroPlanner NE Update Configuration File , page 3-40
Required/As Needed	Required
Onsite/Remote	Onsite or remote
Security Level	Superuser



Note The DCCs, GCCs, and OSCs should not be provisioned between SONET (ANSI) and SDH (ETSI) nodes using CTC or TL1 because they cannot operate between SONET and SDH nodes. These communication channels should be provisioned on similar nodes, such as SONET-to-SONET or SDH-to-SDH.

- Step 1** Complete the “DLP-G46 Log into CTC” task on page 2-27 at the node where you want to provision the OSC terminations. If you are already logged in, continue with [Step 2](#).
- Step 2** In node view (single-shelf mode) or multishelf view (multishelf mode), click the **Provisioning > Comm Channels > OSC** tabs.
- Step 3** In the OSC Terminations area, click **Create** ([Figure 3-27](#)).

Figure 3-27 OSC Terminations Area

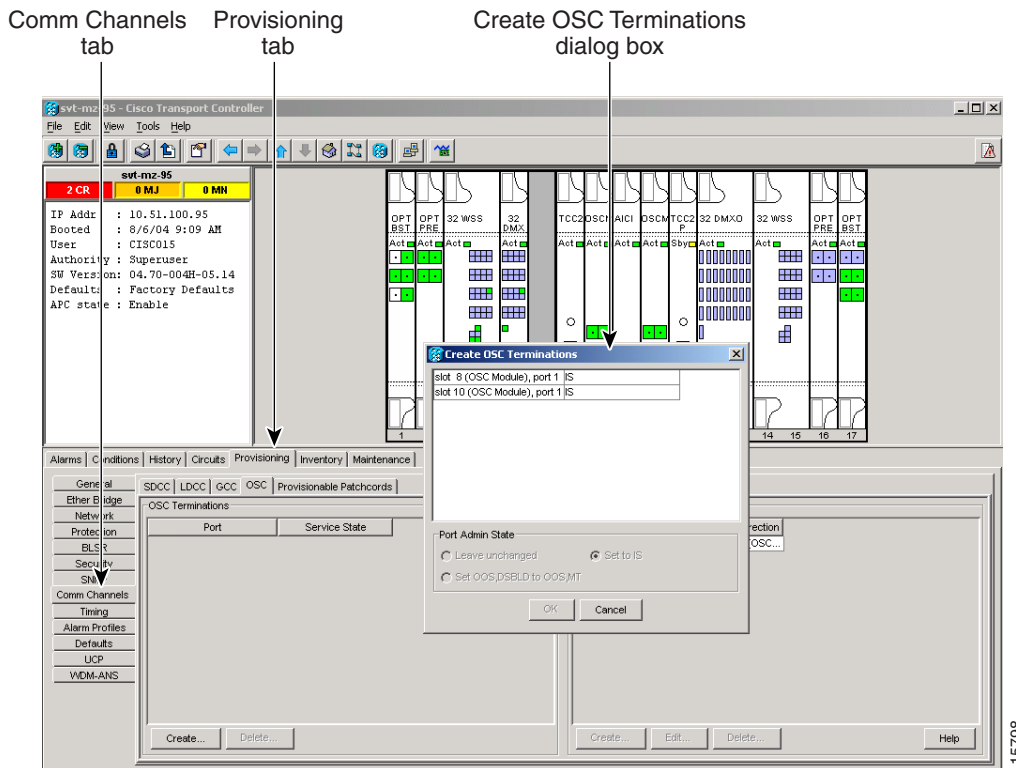

- Step 4** In the Create OSC Terminations dialog box, choose the ports where you want to create the OSC termination. To select more than one port, press the **Shift** key (to select a range of ports) or the **Ctrl** key (to select multiple individual ports).



Note The number of OSC terminations you create depends on the node type defined by Cisco MetroPlanner. Terminal nodes require one OSC termination. Hub, OADM, and ROADM nodes require two OSC termination.

- Step 5** In the Layer 3 area, check the OSI box if the OSC termination is between the ONS 15454 and another ONS node, and third party network elements (NEs) that use the OSI protocol stack are on the same network. If you checked OSI, complete the following steps. If not, continue with [Step 6](#).
- Click **Next**.
 - Provision the following fields:
 - Router—Choose the OSI router.

- ESH—Set the ESH propagation frequency. End system NEs transmit ESHs to inform other ESs and ISs about the NSAPs they serve. The default is 10 seconds. The range is 10 to 1000 seconds.
- ISH—Sets the ISH PDU propagation frequency. Intermediate system NEs send ISHs to other ESs and ISs to inform them about the IS NETs it serves. The default is 10 seconds. The range is 10 to 1000 seconds.
- IIH—Sets the IIH PDU propagation frequency. The IS-IS Hello PDUs establish and maintain adjacencies between ISs. The default is 3 seconds. The range is 1 to 600 seconds.
- Metric—Sets the cost for sending packets on the LAN subnet. The IS-IS protocol uses the cost to calculate the shortest routing path. The default metric cost for LAN subnets is 20. It normally should not be changed.

Step 6 Click **Finish**. Ports are automatically placed in service. The following alarms might appear in the node view (single-shelf mode) or multishelf view (multishelf mode) Alarms tab Description field. They will remain until all the network OSC connections between the adjacent nodes are created:

- SDCC Termination Failure on the OSCM or OSC-CSM card
- LOS on the OC-3 port (Port 1) on the OSCM, OSC-CSM, or OPT-BST card
- OPWR-LFAIL on the OPT-BST or OSC-CSM card



Note After the OSC termination is created, the line ports are placed in service and span power levels are checked.

Stop. You have completed this procedure.

NTP-G39 Verify OSCM Transmit Power

Purpose	This procedure verifies that the transmit power for the ONS 15454 OSCM and the OSC-CSM cards is correct.
Tools/Equipment	None
Prerequisite Procedures	NTP-G37 Run Automatic Node Setup, page 3-86
Required/As Needed	Required
Onsite/Remote	Onsite or remote
Security Level	Superuser

Step 1 Complete the “[DLP-G46 Log into CTC](#)” task on page 2-27 at the node where you want to verify the OSCM or OSC-CSM transmit power. If you are already logged in, continue with [Step 2](#).

Step 2 Disable ALS on the west or (for terminal nodes) the terminal side OSCM or OSC-CSM card:

- a. In the node view (single-shelf mode) or shelf view (multishelf mode), double-click the west or terminal-side OSCM or OSC-CSM card.
- b. Click the **Maintenance > ALS** tabs.
- c. From the ALS Mode drop-down list, choose **Disable**.
- d. Click **Apply**. Click **Yes** on the confirmation dialog box.

- Step 3** If an OSC-CSM or OSCM card is installed on the east side, complete the following steps. If not, continue with [Step 4](#).
- In the node view (single-shelf mode) or shelf view (multishelf mode), double-click the east OSCM or OSC-CSM card.
 - Click the **Maintenance > ALS** tabs.
 - From the ALS Mode drop-down list, choose **Disable**.
 - Click **Apply**. Click **Yes** on the confirmation dialog box.
- Step 4** Complete the [“DLP-G314 Verify OSCM Transmit Power” task on page 3-90](#).
- Step 5** Change ALS to Auto Restart on the west or (for terminal nodes) the terminal side OSCM or OSC-CSM card:
- In the node view (single-shelf mode) or shelf view (multishelf mode), double-click the west or terminal-side OSCM or OSC-CSM card.
 - Click the **Maintenance > ALS** tabs.
 - From the ALS Mode drop-down list, choose **Auto Restart**.
 - Click **Apply**. Click **Yes** on the confirmation dialog box.
- Step 6** If an OSC-CSM or OSCM card is installed on the east side, complete the following steps. If not, you have completed this procedure.
- In the node view (single-shelf mode) or shelf view (multishelf mode), double-click the east OSCM or OSC-CSM card.
 - Click the **Maintenance > ALS** tabs.
 - From the ALS Mode drop-down list, choose **Auto Restart**.
 - Click **Apply**. Click **Yes** on the confirmation dialog box.
- Stop. You have completed this procedure.**
-

DLP-G314 Verify OSCM Transmit Power

Purpose	This procedure verifies that the transmit power of the OSCM card is correct.
Tools/Equipment	None
Prerequisite Procedures	“DLP-G46 Log into CTC” task on page 2-27
Required/As Needed	Required
Onsite/Remote	Onsite or remote
Security Level	Superuser



Note Throughout this task, west refers to Slots 1 through 8, and east refers to Slots 10 through 17.

- Step 1** Display the OSCM card in card view.
- Step 2** Click the **Provisioning > Optical Line > Parameters** tabs.

- Step 3** Record the Port 3 (OSC TX) Power value: _____. If an OPT-PRE card is installed in the same side of the shelf as the OSCM, continue with [Step 4](#). If not, verify that the value is equal to -5 dBm \pm 0.5 dBm. If so, continue with [Step 7](#). If not, continue with [Step 6](#), Substep [a](#).
- Step 4** Change to node view (single-shelf mode) or multishelf view (multishelf mode), then click the **Provisioning > WDM-ANS** tabs.
- Step 5** Record the amplifier working mode value from one of the following:
For OSCM cards installed on the east side:
- In the Selector window on the left, expand the East Side parameters tree view.
 - Expand the RX category.
 - Expand the Amplifier category, then highlight **Working Mode**.
 - Record the EastSide.Rx.Amplifier.Working Mode parameter displayed in the right pane: _____
- For OSCM cards installed on the west side:
- In the Selector window on the left, expand the West Side parameters tree view.
 - Expand the RX category.
 - Expand the Amplifier category, then highlight **Working Mode**.
 - Record the WestSide.Rx.Amplifier.Working Mode parameter displayed in the right pane: _____
- Step 6** If the working mode recorded in [Step 5](#) is Control Gain, verify that the value recorded in [Step 3](#) is equal to -5 dBm \pm 0.5 dBm. If the value recorded in [Step 5](#) is Control Power, verify that the value recorded in [Step 3](#) is equal to 0.5 dBm, \pm 0.5 dBm. If the power level is not within this range, complete the following steps. Otherwise, continue with [Step 7](#).
- Click the **Maintenance > ALS** tabs. Verify that the ALS Command is set to OSRI Off. If not, click the cell and choose **Off** from the drop-down list. Click **Apply**, then click **Yes**.
 - Clean the optical connections. See the [“NTP-G115 Clean Fiber Connectors” procedure on page 13-25](#).
 - Complete the following procedures:
 - Delete the two OSC channels using the [“DLP-G186 Delete an OSC Termination” task on page 10-45](#).
 - Complete the [“NTP-G37 Run Automatic Node Setup” procedure on page 3-86](#).
 - Create the OSC channels using the [“NTP-G38 Provision OSC Terminations” procedure on page 3-87](#).
 - Repeat [Step 3](#) through [Step 6](#). If the power level is still not within the specified range, contact your next level of support.
- Step 7** Return to your originating procedure (NTP).
-

NTP-G163 Upgrade Nodes in Single-Shelf Mode to Multishelf Mode

Purpose	This procedure upgrades nodes in single-shelf mode to multishelf mode.
Tools/Equipment	The node you plan to use as the node controller must be equipped with optical units and cannot have a cross-connect card installed. Any nodes that you plan to add to the multishelf configuration as subtending shelves can be equipped with transponder and muxponder units. For more information on multishelf configurations, see the “Node Reference” chapter in the <i>Cisco ONS 15454 DWDM Reference Manual</i> .
Prerequisite Procedures	<p>NTP-G22 Verify Common Card Installation, page 3-4</p> <p>NTP-G145 Connect a Multishelf Node and Subtending Shelves to an MS-ISC-100T Card, page 1-81 or</p> <p>NTP-G158 Connect a Multishelf Node and Subtending Shelves to a Catalyst 2950, page 1-83</p> <p>DLP-G347 Delete Optical Channel Client Connections, page 7-8 if circuits exist on the transponder/muxponder shelf to be upgraded</p> <p>DLP-G187 Delete a Provisionable Patchcord, page 10-45 as needed on the transponder/muxponder shelf to be upgraded</p>



Caution

Upgrading a single-shelf transponder/muxponder shelf to a subtending shelf in a multishelf node is traffic affecting if OCHCC circuits exist on external patchcords between the OCh filters of the node controller and TXP/MXP trunk ports of the shelf to be upgraded. Before beginning the upgrade procedure, you must delete the OCHCC circuits and the external patchcords. You will replace them with internal patchcords between the optical shelf (node controller) and the preprovisioned TXP/MXP subtending shelf when performing the upgrade procedure.

Required/As Needed	As needed
Onsite/Remote	Onsite
Security Level	Superuser



Caution

An optical shelf in a multishelf configuration must be provisioned as the node controller shelf and not a subtending shelf, otherwise traffic will be dropped. If no slots are available on an optical shelf to install the MS-ISC-100T cards needed for a node controller shelf, install and configure the Cisco Catalyst 2950. See the “[NTP-G158 Connect a Multishelf Node and Subtending Shelves to a Catalyst 2950](#)” section on [page 1-83](#).



Note

CTM users can use the CTM NE Explorer to monitor and configure single-shelf and multishelf nodes. When the upgrade is complete, the original individual subtending shelves will be in the CTM network view and must be manually deleted. For detailed information, refer to the *Cisco Transport Manager User Guide*, Appendix B, “NE Explorer Information.”

- Step 1** Complete the “[DLP-G46 Log into CTC](#)” task on page 2-27 at the node that you want to configure as a multishelf node.
- Step 2** If you want to configure a shelf as the node controller, continue with [Step 3](#). If you want to configure a shelf as a subtending shelf, continue with [Step 4](#).
- Step 3** To set up the login node as the node controller, complete the following steps:
- In node view (single-node mode) or multishelf view (multishelf mode), click the **Provisioning > General > Multishelf Config** tabs.
 - Click **Enable as Node Controller**.
 - From the LAN Config drop-down list, complete one of the following:
 - Choose **Ethernet Switch** if MS-ISC-100T cards or the Catalyst 2950 switches are already installed and configured.
 - Choose **Stand-Alone** if MS-ISC-100T cards are not installed yet but will be in the final layout or if this is a line amplifier or an OSC-only site. This option will allow a safe migration of the TCC2/TCC2P database when the multishelf configuration is complete.
 - Click **Apply**.
 - In the confirmation dialog box, click **Yes** to allow the node to reboot. The CTC view changes to network view and the node icon changes to gray. Wait for the reboot to finish. (This might take several minutes.)
 - After the node reboots, double-click the node. The multishelf view appears.



Note The shelf ID of the node controller is automatically assigned as 1.

- Step 4** To add a node equipped with transponder and muxponder cards as a subtending shelf in the multishelf configuration, complete the following:
- In multishelf view, right-click in the white space in the rack and choose **Add Shelf**.
 - In the Shelf ID Selection dialog box, choose a shelf ID (from 2 to 8) from the drop-down list.
 - Click **OK**. The shelf appears in the multishelf view.
 - Preprovision the new shelf so that it has the same provisioning as the actual shelf that you will add as the subtending shelf:



Caution

If the subtending shelf is not preprovisioned, traffic will be lost.

- Cards, PPMs, administrative states, client and trunk port configuration—For more information on card and port settings, see [Chapter 5, “Provision Transponder and Muxponder Cards.”](#)
 - Timing—For more information, see the “[NTP-G53 Set Up Timing](#)” procedure on page 6-4.
 - GCC—For more information, see the “[DLP-G76 Provision DCC/GCC Terminations](#)” task on page 7-21.
 - Internal patchcords—Replace the deleted external patchcords with internal patchcords between the optical shelf (node controller) and the preprovisioned TXP/MXP subtending shelf. For more information, see the “[NTP-G152 Create and Verify Internal Patchcords](#)” procedure on page 3-82.
- Disconnect the cross-over (CAT-5) LAN cable from the RJ-45 (LAN) port of the subtending shelf TCC2/TCC2P card in Slot 11.

- f. Connect your Windows PC or Solaris workstation NIC to the RJ-45 (LAN) port on the TTC2/TCC2P card in Slot 11.
- g. Complete the “[DLP-G46 Log into CTC](#)” task on page 2-27 at the subtending shelf.
- h. Click the **Provisioning > General > Multishelf Config** tabs.
- i. Click **Enable as Subtended Shelf**.
- j. From the Shelf ID drop-down list, choose the shelf ID that you created in Step b.
- k. Click **Apply**.
- l. In the confirmation dialog box, click **Yes** to reboot the shelf. The CTC view changes to network view and the node icon changes to gray. Wait for the reboot to finish. (This might take several minutes.)
- m. Disconnect your Windows PC or Solaris workstation NIC from the RJ-45 (LAN) port of the subtending shelf TTC2/TCC2P card in Slot 11.
- n. Reconnect the cross-over (CAT-5) LAN cable (disconnected in Step e) to the RJ-45 (LAN) port of the subtending shelf TCC2/TCC2P card in Slot 11.
- o. Repeat Steps a through n to set up additional subtending shelves.



Note CTM users can use the CTM NE Explorer to monitor and configure single-shelf and multishelf nodes. When the upgrade is complete, the original individual subtending shelves will remain the CTM network view and must be manually deleted. For detailed information, refer to the *Cisco Transport Manager User Guide*, Appendix B, “NE Explorer Information.”

Stop. You have completed this procedure.
