



Cisco ONS 15454 DWDM Troubleshooting Guide

Product and Software Release 9.0
June 2012

Americas Headquarters
Cisco Systems, Inc.
170 West Tasman Drive
San Jose, CA 95134-1706
USA
<http://www.cisco.com>
Tel: 408 526-4000
800 553-NETS (6387)
Fax: 408 527-0883

Text Part Number: 78-18378-02

THE SPECIFICATIONS AND INFORMATION REGARDING THE PRODUCTS IN THIS MANUAL ARE SUBJECT TO CHANGE WITHOUT NOTICE. ALL STATEMENTS, INFORMATION, AND RECOMMENDATIONS IN THIS MANUAL ARE BELIEVED TO BE ACCURATE BUT ARE PRESENTED WITHOUT WARRANTY OF ANY KIND, EXPRESS OR IMPLIED. USERS MUST TAKE FULL RESPONSIBILITY FOR THEIR APPLICATION OF ANY PRODUCTS.

THE SOFTWARE LICENSE AND LIMITED WARRANTY FOR THE ACCOMPANYING PRODUCT ARE SET FORTH IN THE INFORMATION PACKET THAT SHIPPED WITH THE PRODUCT AND ARE INCORPORATED HEREIN BY THIS REFERENCE. IF YOU ARE UNABLE TO LOCATE THE SOFTWARE LICENSE OR LIMITED WARRANTY, CONTACT YOUR CISCO REPRESENTATIVE FOR A COPY.

The following information is for FCC compliance of Class A devices: This equipment has been tested and found to comply with the limits for a Class A digital device, pursuant to part 15 of the FCC rules. These limits are designed to provide reasonable protection against harmful interference when the equipment is operated in a commercial environment. This equipment generates, uses, and can radiate radio-frequency energy and, if not installed and used in accordance with the instruction manual, may cause harmful interference to radio communications. Operation of this equipment in a residential area is likely to cause harmful interference, in which case users will be required to correct the interference at their own expense.

The following information is for FCC compliance of Class B devices: The equipment described in this manual generates and may radiate radio-frequency energy. If it is not installed in accordance with Cisco's installation instructions, it may cause interference with radio and television reception. This equipment has been tested and found to comply with the limits for a Class B digital device in accordance with the specifications in part 15 of the FCC rules. These specifications are designed to provide reasonable protection against such interference in a residential installation. However, there is no guarantee that interference will not occur in a particular installation.

Modifying the equipment without Cisco's written authorization may result in the equipment no longer complying with FCC requirements for Class A or Class B digital devices. In that event, your right to use the equipment may be limited by FCC regulations, and you may be required to correct any interference to radio or television communications at your own expense.

You can determine whether your equipment is causing interference by turning it off. If the interference stops, it was probably caused by the Cisco equipment or one of its peripheral devices. If the equipment causes interference to radio or television reception, try to correct the interference by using one or more of the following measures:

- Turn the television or radio antenna until the interference stops.
- Move the equipment to one side or the other of the television or radio.
- Move the equipment farther away from the television or radio.
- Plug the equipment into an outlet that is on a different circuit from the television or radio. (That is, make certain the equipment and the television or radio are on circuits controlled by different circuit breakers or fuses.)

Modifications to this product not authorized by Cisco Systems, Inc. could void the FCC approval and negate your authority to operate the product.

The Cisco implementation of TCP header compression is an adaptation of a program developed by the University of California, Berkeley (UCB) as part of UCB's public domain version of the UNIX operating system. All rights reserved. Copyright © 1981, Regents of the University of California.

NOTWITHSTANDING ANY OTHER WARRANTY HEREIN, ALL DOCUMENT FILES AND SOFTWARE OF THESE SUPPLIERS ARE PROVIDED "AS IS" WITH ALL FAULTS. CISCO AND THE ABOVE-NAMED SUPPLIERS DISCLAIM ALL WARRANTIES, EXPRESSED OR IMPLIED, INCLUDING, WITHOUT LIMITATION, THOSE OF MERCHANTABILITY, FITNESS FOR A PARTICULAR PURPOSE AND NONINFRINGEMENT OR ARISING FROM A COURSE OF DEALING, USAGE, OR TRADE PRACTICE.

IN NO EVENT SHALL CISCO OR ITS SUPPLIERS BE LIABLE FOR ANY INDIRECT, SPECIAL, CONSEQUENTIAL, OR INCIDENTAL DAMAGES, INCLUDING, WITHOUT LIMITATION, LOST PROFITS OR LOSS OR DAMAGE TO DATA ARISING OUT OF THE USE OR INABILITY TO USE THIS MANUAL, EVEN IF CISCO OR ITS SUPPLIERS HAVE BEEN ADVISED OF THE POSSIBILITY OF SUCH DAMAGES.

Cisco and the Cisco logo are trademarks or registered trademarks of Cisco and/or its affiliates in the U.S. and other countries. To view a list of Cisco trademarks, go to this URL: www.cisco.com/go/trademarks. Third-party trademarks mentioned are the property of their respective owners. The use of the word partner does not imply a partnership relationship between Cisco and any other company. (1110R)

Any Internet Protocol (IP) addresses used in this document are not intended to be actual addresses. Any examples, command display output, and figures included in the document are shown for illustrative purposes only. Any use of actual IP addresses in illustrative content is unintentional and coincidental.

Cisco ONS 15454 DWDM Troubleshooting Guide, Release 9.0
Copyright © 2007–2012 Cisco Systems, Inc. All rights reserved.



CONTENTS

Preface xxxi

Revision History	xxxix
Document Objectives	xxxix
Audience	xxxix
Document Organization	xxxix
Related Documentation	xxxix
Document Conventions	xxxix
Obtaining Optical Networking Information	xi
Where to Find Safety and Warning Information	xi
Cisco Optical Networking Product Documentation CD-ROM	xi
Obtaining Documentation and Submitting a Service Request	xi

CHAPTER 1

General Troubleshooting 1-1

1.1 Loopback Description	1-2
1.1.1 Facility Loopbacks	1-2
1.1.1.1 General Behavior	1-3
1.1.1.2 Card Behavior	1-3
1.1.2 Terminal Loopbacks	1-5
1.1.2.1 General Behavior	1-5
1.1.2.2 Card Behavior	1-6
1.2 Troubleshooting MXP, TXP, XP, or ADM-10G Circuit Paths With Loopbacks	1-7
1.2.1 Perform a Facility Loopback on a Source-Node MXP or TXP Port	1-8
Create the Facility Loopback on the Source-Node MXP, TXP, XP or ADM-10G Port	1-9
Test and Clear the MXP, TXP, XP or ADM-10G Facility Loopback Circuit	1-10
Test the MXP, TXP, XP or ADM-10G Card	1-11
1.2.2 Perform a Terminal Loopback on a Source-Node MXP, TXP, XP, or ADM-10G Port	1-11
Create the Terminal Loopback on a Source-Node MXP, TXP, XP, or ADM-10G Port	1-12
Test and Clear the MXP, TXP, XP, or ADM-10G Port Terminal Loopback Circuit	1-13
Test the MXP, TXP, XP, or ADM-10G Card	1-13
1.2.3 Create a Facility Loopback on an Intermediate-Node MXP or TXP Port	1-14
Create a Facility Loopback on an Intermediate-Node MXP or TXP Port	1-15
Test and Clear the MXP or TXP Port Facility Loopback Circuit	1-16
Test the MXP or TXP Card	1-16
1.2.4 Create a Terminal Loopback on Intermediate-Node MXP or TXP Ports	1-17

Create a Terminal Loopback on Intermediate-Node MXP or TXP Ports	1-17
Test and Clear the MXP or TXP Terminal Loopback Circuit	1-18
Test the MXP or TXP Card	1-19
1.2.5 Perform a Facility Loopback on a Destination-Node MXP, TXP, XP, or ADM-10G Port	1-19
Create the Facility Loopback on a Destination-Node MXP, TXP, XP, or ADM-10G Port	1-20
Test and Clear the MXP, TXP, XP, or ADM-10G Facility Loopback Circuit	1-21
Test the MXP, TXP, XP, or ADM-10G Card	1-21
1.2.6 Perform a Terminal Loopback on a Destination-Node MXP, TXP, XP, or ADM-10G Port	1-22
Create the Terminal Loopback on a Destination-Node MXP, TXP, XP, or ADM-10G Port	1-23
Test and Clear the MXP, TXP, XP, or ADM-10G Terminal Loopback Circuit	1-23
Test the MXP, TXP, XP, or ADM-10G Card	1-24
1.3 Troubleshooting DWDM Circuit Paths With ITU-T G.709 Monitoring	1-25
1.3.1 ITU-T G.709 Monitoring in Optical Transport Networks	1-25
1.3.2 Optical Channel Layer	1-25
1.3.3 Optical Multiplex Section Layer	1-26
1.3.4 Optical Transmission Section Layer	1-26
1.3.5 Performance Monitoring Counters and Threshold Crossing Alerts	1-26
Set Node Default BBE or SES Card Thresholds	1-27
Provision Individual Card BBE or SES Thresholds in CTC	1-28
Provision Card PM Thresholds Using TL1	1-29
Provision Optical TCA Thresholds	1-30
1.3.6 Forward Error Correction	1-30
Provision Card FEC Thresholds	1-31
1.3.7 Sample Trouble Resolutions	1-31
1.4 Using CTC Diagnostics	1-33
1.4.1 Card LED Lamp Tests	1-33
Verify Card LED Operation	1-33
1.4.2 Retrieve Tech Support Logs Button	1-34
Off-Load the Diagnostics File	1-35
1.4.3 Data Communications Network Tool	1-36
1.5 Restoring the Database and Default Settings	1-37
1.5.1 Restore the Node Database	1-37
1.6 PC Connectivity Troubleshooting	1-38
1.6.1 PC System Minimum Requirements	1-38
1.6.2 Sun System Minimum Requirements	1-38
1.6.3 Supported Platforms, Browsers, and JREs	1-38
1.6.4 Unsupported Platforms and Browsers	1-39
1.6.5 Unable to Verify the IP Configuration of Your PC	1-39
Verify the IP Configuration of Your PC	1-39

- 1.6.6 Browser Login Does Not Launch Java 1-40
 - Reconfigure the PC Operating System Java Plug-in Control Panel 1-40
 - Reconfigure the Browser 1-41
- 1.6.7 Unable to Verify the NIC Connection on Your PC 1-41
- 1.6.8 Verify PC Connection to the ONS 15454 (ping) 1-42
 - Ping the ONS 15454 1-42
- 1.6.9 The IP Address of the Node is Unknown 1-43
 - Retrieve Unknown Node IP Address 1-43
- 1.7 CTC Operation Troubleshooting 1-43
 - 1.7.1 CTC Colors Do Not Appear Correctly on a UNIX Workstation 1-44
 - Limit Netscape Colors 1-44
 - 1.7.2 Unable to Launch CTC Help After Removing Netscape 1-44
 - Reset Internet Explorer as the Default Browser for CTC 1-44
 - 1.7.3 Unable to Change Node View to Network View 1-45
 - Set the CTC_HEAP and CTC_MAX_PERM_SIZE_HEAP Environment Variables for Windows 1-45
 - Set the CTC_HEAP and CTC_MAX_PERM_SIZE_HEAP Environment Variables for Solaris 1-46
 - 1.7.4 Browser Stalls When Downloading CTC JAR Files From TCC2/TCC2P Card 1-46
 - Disable the VirusScan Download Scan 1-46
 - 1.7.5 CTC Does Not Launch 1-47
 - Redirect the Netscape Cache to a Valid Directory 1-47
 - 1.7.6 Slow CTC Operation or Login Problems 1-47
 - Delete the CTC Cache File Automatically 1-48
 - Delete the CTC Cache File Manually 1-49
 - 1.7.7 Node Icon is Gray on CTC Network View 1-50
 - 1.7.8 Java Runtime Environment Incompatible 1-50
 - Launch CTC to Correct the Core Version Build 1-51
 - 1.7.9 Different CTC Releases Do Not Recognize Each Other 1-51
 - Launch CTC to Correct the Core Version Build 1-52
 - 1.7.10 Username or Password Do Not Match 1-52
 - Verify Correct Username and Password 1-52
 - 1.7.11 DCC Connection Lost 1-53
 - 1.7.12 "Path in Use" Error When Creating a Circuit 1-53
 - 1.7.13 Calculate and Design IP Subnets 1-53
- 1.8 Timing 1-53
 - 1.8.1 ONS 15454 Switches Timing Reference 1-54
 - 1.8.2 Holdover Synchronization Alarm 1-54
 - 1.8.3 Free-Running Synchronization Mode 1-55
 - 1.8.4 Daisy-Chained BITS Not Functioning 1-55
 - 1.8.5 Blinking STAT LED after Installing a Card 1-55

- 1.9 Fiber and Cabling **1-56**
 - 1.9.1 Bit Errors Appear for a Traffic Card **1-56**
 - 1.9.2 Faulty Fiber-Optic Connections **1-56**
 - 1.9.2.1 Crimp Replacement LAN Cables **1-57**
 - 1.9.2.2 Replace Faulty SFP or XFP Connectors **1-58**
 - Remove SFP or XFP Connectors **1-59**
 - Install an SFP or XFP Connector **1-59**
- 1.10 Power Supply Problems **1-59**
 - Isolate the Cause of Power Supply Problems **1-60**
- 1.11 Power Up Problems for Node and Cards **1-61**
- 1.12 Network Level (Internode) Problems **1-61**
 - 1.12.1 Fiber Cut Detection **1-61**
 - 1.12.1.1 Scenario A **1-62**
 - 1.12.1.2 Scenario B **1-65**
 - Fix a Fiber Cut **1-68**
 - 1.12.2 System Restart after a Fiber Cut **1-70**
 - 1.12.2.1 Scenario 1: Span Loss Change > 5 dBm and OSC Power Value on the Receiver < -42 dBm **1-70**
 - 1.12.2.2 Scenario 2: Span Loss Change > 5 dBm and OSC Power Value on the Receiver > -42 dBm **1-72**
 - 1.12.2.3 Scenario 3: 3 dBm < Span Loss Change < 5 dBm **1-75**
 - 1.12.2.4 Scenario 4: Span Loss Change < 3 dB **1-78**
 - 1.12.3 OCHNC Circuits Creation Failure **1-80**
 - 1.12.3.1 Prerequisites for Successful OCHNC Circuit Creation **1-80**
 - 1.12.3.2 Conditions for OCHNC Circuit Creation Failure **1-81**
 - 1.12.3.3 Scenarios for OCHNC Circuit Creation Failure **1-83**
- 1.13 Node Level (Intranode) Problems **1-85**
 - 1.13.1 VOA Startup Phases **1-85**
 - 1.13.1.1 Phase 1: Incoming Signal Validation **1-86**
 - 1.13.1.2 Phase 2: Valid Signal Detected **1-86**
 - 1.13.1.3 Phase 3: Channel Power Setpoint Locking **1-87**
 - 1.13.1.4 Phase 4: Channel Power Control Mode Fully Activated **1-87**
 - 1.13.2 VOA Failure Scenarios **1-87**
 - 1.13.2.1 Scenario A: Optical Power Level of the Incoming Signal Lower Than Minimum Allowed by MSTP Supported Optical Interfaces **1-87**
 - 1.13.2.2 Scenario B: Optical Power Level of the Incoming Signal Lower Than Expected **1-92**
 - Corrective Actions for Scenario B (Optical Power Level of Incoming Signal Lower than Expected) **1-94**
 - 1.13.2.3 Scenario C: Optical Drop Power Level Lower Than Expected **1-100**

Corrective Action for Scenario C (Optical Power Level of Incoming Signal Lower than Expected)	1-102
1.13.3 Counter-Propagating Light Affecting Operation of 32DMX-C and 32DMX-L Cards	1-106
Corrective Action—Software Releases Lower than 9.0	1-107

CHAPTER 2**Alarm Troubleshooting 2-1**

2.1 Alarm Indexes	2-1
2.1.1 Critical Alarms (CR)	2-2
2.1.2 Major Alarms (MJ)	2-2
2.1.3 Minor Alarms (MN)	2-3
2.1.4 NA Conditions	2-5
2.1.5 NR Conditions	2-8
2.1.6 Alarms and Conditions Listed By Alphabetical Entry	2-8
2.2 Logical Objects	2-14
2.2.1 Alarm Logical Objects	2-14
2.2.2 Alarm List by Logical Object Type	2-16
2.3 Trouble Characterizations	2-23
2.3.1 Alarm Characteristics	2-24
2.3.2 Condition Characteristics	2-24
2.3.3 Severity	2-24
2.3.4 Service Effect	2-25
2.3.5 State	2-25
2.4 Safety Summary	2-25
2.5 Trouble-Clearing Procedures	2-26
2.5.1 AIS	2-26
Clear the AIS Condition	2-27
2.5.2 AIS-L	2-27
Clear the AIS-L Condition	2-27
2.5.3 AIS-P	2-27
Clear the AIS-P Condition	2-28
2.5.4 ALS	2-28
2.5.5 ALS-DISABLED	2-28
Clear the ALS-DISABLED Condition	2-28
2.5.6 AMPLI-INIT	2-28
Clear the AMPLI-INIT Condition	2-29
2.5.7 APC-CORR-SKIPPED	2-29
2.5.8 APC-DISABLED	2-29
Clear the APC-DISABLED Alarm	2-30
2.5.9 APC-END	2-30

2.5.10	APC-OUT-OF-RANGE	2-31	
	Clear the APC-OUT-OF-RANGE Alarm	2-31	
2.5.11	APC-WRONG-GAIN	2-31	
	Clear the APC-WRONG-GAIN Alarm	2-32	
2.5.12	APSB	2-32	
	Clear the APSB Alarm	2-32	
2.5.13	APSCM	2-32	
	Clear the APSCM Alarm	2-33	
2.5.14	APSIMP	2-33	
	Clear the APSIMP Alarm	2-34	
2.5.15	APS-INV-PRIM	2-34	
2.5.16	APSMM	2-34	
	Clear the APSMM Alarm	2-35	
2.5.17	APS-PRIM-FAC	2-35	
	Clear the APS-PRIM-FAC Condition	2-35	
2.5.18	APS-PRIM-SEC-MISM	2-35	
	Clear the APS-PRIM-SEC-MISM Alarm	2-36	
2.5.19	AS-CMD	2-36	
	Clear the AS-CMD Condition	2-36	
2.5.20	AS-MT	2-37	
	Clear the AS-MT Condition	2-38	
2.5.21	AU-AIS	2-38	
	Clear the AU-AIS Condition	2-38	
2.5.22	AU-LOP	2-38	
	Clear the AU-LOP Alarm	2-39	
2.5.23	AUTOLSROFF	2-39	
	Clear the AUTOLSROFF Alarm	2-40	
2.5.24	AUTORESET	2-40	
	Clear the AUTORESET Alarm	2-41	
2.5.25	AUTOSW-AIS	2-41	
	Clear the AUTOSW-AIS Condition	2-41	
2.5.26	AUTOSW-AIS-SNCP	2-41	
	Clear the AUTOSW-AIS-path protection Condition	2-42	
2.5.27	AUTOSW-LOP (STSMON)	2-42	
	Clear the AUTOSW-LOP (STSMON) Condition	2-42	
2.5.28	AUTOSW-LOP-SNCP	2-42	
	Clear the AUTOSW-LOP-SNCP Alarm	2-43	
2.5.29	AUTOSW-PDI	2-43	
	Clear the AUTOSW-PDI Condition	2-43	
2.5.30	AUTOSW-PDI-SNCP	2-43	

Clear the AUTOSW-PDI-SNCP Condition	2-44
2.5.31 AUTOSW-SDBER	2-44
Clear the AUTOSW-SDBER Condition	2-44
2.5.32 AUTOSW-SDBER-SNCP	2-44
Clear the AUTOSW-SDBER-SNCP Condition	2-45
2.5.33 AUTOSW-SFBER	2-45
Clear the AUTOSW-SFBER Condition	2-45
2.5.34 AUTOSW-SFBER-SNCP	2-45
Clear the AUTOSW-SFBER-SNCP Condition	2-45
2.5.35 AUTOSW-UNEQ (STSMON)	2-46
Clear the AUTOSW-UNEQ (STSMON) Condition	2-46
2.5.36 AUTOSW-UNEQ-SNCP (VCMON-HP)	2-46
Clear the AUTOSW-UNEQ-SNCP (VCMON-HP) Condition	2-47
2.5.37 AWG-DEG	2-47
Clear the AWG-DEG Alarm	2-47
2.5.38 AWG-FAIL	2-48
Clear the AWG-FAIL Alarm	2-48
2.5.39 AWG-OVERTEMP	2-48
Clear the AWG-OVERTEMP Alarm	2-48
2.5.40 AWG-WARM-UP	2-49
2.5.41 BAT-FAIL	2-49
Clear the BAT-FAIL Alarm	2-49
2.5.42 BKUPMEMP	2-49
Clear the BKUPMEMP Alarm	2-50
2.5.43 BPV	2-50
Clear the BPV Alarm	2-51
2.5.44 CARLOSS (EQPT)	2-51
Clear the CARLOSS (EQPT) Alarm	2-52
2.5.45 CARLOSS (FC)	2-53
Clear the CARLOSS (FC) Alarm	2-53
2.5.46 CARLOSS (GE)	2-53
Clear the CARLOSS (GE) Alarm	2-54
2.5.47 CARLOSS (ISC)	2-54
Clear the CARLOSS (ISC) Alarm	2-55
2.5.48 CARLOSS (TRUNK)	2-55
Clear the CARLOSS (TRUNK) Alarm	2-55
2.5.49 CASETEMP-DEG	2-56
Clear the CASETEMP-DEG Alarm	2-56
2.5.50 CHANLOSS	2-57
Clear the CHANLOSS Condition	2-57

2.5.51	CLDRESTART	2-57
	Clear the CLDRESTART Condition	2-58
2.5.52	CONTBUS-DISABLED	2-58
	Clear the CONTBUS-DISABLED Alarm	2-58
2.5.53	CONTBUS-IO-A	2-59
	Clear the CONTBUS-IO-A Alarm	2-59
2.5.54	CONTBUS-IO-B	2-60
	Clear the CONTBUS-IO-B Alarm	2-60
2.5.55	CTNEOPT-MISMATCH	2-61
	Clear the CTNEOPT-MISMATCH Condition	2-61
2.5.56	DATAFLT	2-62
	Clear the DATAFLT Alarm	2-62
2.5.57	DBOSYNC	2-62
	Clear the DBOSYNC Alarm	2-63
2.5.58	DCU-LOSS-FAIL	2-63
	Clear the DCU-LOSS-FAIL Condition	2-63
2.5.59	DISCONNECTED	2-63
	Clear the DISCONNECTED Alarm	2-64
2.5.60	DSP-COMM-FAIL	2-64
2.5.61	DSP-FAIL	2-64
	Clear the DSP-FAIL Alarm	2-64
2.5.62	DUP-IPADDR	2-65
	Clear the DUP-IPADDR Alarm	2-65
2.5.63	DUP-NODENAME	2-65
	Clear the DUP-NODENAME Alarm	2-65
2.5.64	DUP-SHELF-ID	2-66
	Clear the DUP-SHELF-ID Alarm	2-66
2.5.65	EHIBATVG	2-66
	Clear the EHIBATVG Alarm	2-66
2.5.66	ELWBATVG	2-67
	Clear the ELWBATVG Alarm	2-67
2.5.67	ENCAP-MISMATCH-P	2-67
	Clear the ENCAP-MISMATCH-P Alarm	2-68
2.5.68	EOC	2-69
	Clear the EOC Alarm	2-70
2.5.69	EOC-L	2-71
	Clear the EOC-L Alarm	2-72
2.5.70	EQPT	2-72
	Clear the EQPT Alarm	2-73
2.5.71	EQPT-DIAG	2-73

Clear the EQPT-DIAG Alarm	2-73
2.5.72 EQPT-MISS	2-74
Clear the EQPT-MISS Alarm	2-74
2.5.73 ERFI-P-CONN	2-74
Clear the ERFI-P-CONN Condition	2-74
2.5.74 ERFI-P-SRVR	2-75
Clear the ERFI-P-SRVR Condition	2-75
2.5.75 EXCCOL	2-75
Clear the EXCCOL Alarm	2-75
2.5.76 EXT	2-75
Clear the EXT Alarm	2-76
2.5.77 FAILTOSW (2R, EQPT, ESCON, FC, GE, ISC, OCN/STMN, TRUNK, OTS)	2-76
Clear the FAILTOSW (2R, EQPT, ESCON, FC, GE, ISC, OCN/STMN, TRUNK, OTS) Condition	2-76
2.5.78 FAILTOSW (TRUNK)	2-77
Clear the FAILTOSW (TRUNK) Condition	2-77
2.5.79 FAILTOSW-HO	2-77
Clear the FAILTOSW-HO Condition	2-77
2.5.80 FAILTOSW-PATH	2-78
Clear the FAILTOSW-PATH Condition in a Path Protection Configuration	2-78
2.5.81 FAN	2-78
Clear the FAN Alarm	2-79
2.5.82 FAPS	2-79
Clear the FAPS Alarm	2-79
2.5.83 FAPS-CONFIG-MISMATCH	2-79
Clear the FAPS-CONFIG-MISMATCH Condition	2-80
2.5.84 FC-NO-CREDITS	2-80
Clear the FC-NO-CREDITS Alarm	2-80
2.5.85 FDI	2-81
Clear the FDI Condition	2-81
2.5.86 FE-FRCDWKSWBK-SPAN	2-82
Clear the FE-FRCDWKSWBK-SPAN Condition	2-82
2.5.87 FE-FRCDWKSWPR-SPAN	2-82
Clear the FE-FRCDWKSWPR-SPAN Condition	2-82
2.5.88 FE-MANWKSWBK-SPAN	2-83
Clear the FE-MANWKSWBK-SPAN Condition	2-83
2.5.89 FE-MANWKSWPR-SPAN	2-83
Clear the FE-MANWKSWPR-SPAN Condition	2-83
2.5.90 FEC-MISM	2-84
Clear the FEC-MISM Alarm	2-84
2.5.91 FEPRLF	2-85

Clear the FEPRLF Alarm on an BLSR	2-85
2.5.92 FIBERTEMP-DEG	2-85
Clear the FIBERTEMP-DEG Alarm	2-85
2.5.93 FORCED-REQ	2-86
Clear the FORCED-REQ Condition	2-86
2.5.94 FORCED-REQ-SPAN (2R, ESCON, FC, GE, ISC, OCN/STMN, OTS)	2-86
2.5.95 FORCED-REQ-SPAN (TRUNK)	2-87
2.5.96 FP-LINK-LOSS	2-87
Clear the FP-LINK-LOSS Condition	2-87
2.5.97 FRCDSWTOINT	2-87
2.5.98 FRCDSWTOPRI	2-88
2.5.99 FRCDSWTOSEC	2-88
2.5.100 FRCDSWTOTHIRD	2-88
2.5.101 FRNGSYNC	2-88
Clear the FRNGSYNC Condition	2-89
2.5.102 FSTSYNC	2-89
2.5.103 FTA-MISMATCH	2-89
Clear the FTA-MISMATCH Condition	2-89
2.5.104 GAIN-HDEG	2-90
Clear the GAIN-HDEG Alarm	2-90
2.5.105 GAIN-HFAIL	2-91
Clear the GAIN-HFAIL Alarm	2-91
2.5.106 GAIN-LDEG	2-91
Clear the GAIN-LDEG Alarm	2-92
2.5.107 GAIN-LFAIL	2-92
Clear the GAIN-LFAIL Alarm	2-92
2.5.108 GCC-EOC	2-92
Clear the GCC-EOC Alarm	2-93
2.5.109 GE-OOSYNC (FC, GE, ISC)	2-93
Clear the GE-OOSYNC (FC, GE, ISC) Alarm	2-93
2.5.110 GE-OOSYNC (TRUNK)	2-94
Clear the GE-OOSYNC (TRUNK) Alarm	2-94
2.5.111 GFP-CSF	2-94
Clear the GFP-CSF Alarm	2-95
2.5.112 GFP-LFD	2-95
Clear the GFP-LFD Alarm	2-95
2.5.113 GFP-UP-MISMATCH	2-96
Clear the GFP-UP-MISMATCH Alarm	2-96
2.5.114 HELLO	2-96
Clear the HELLO Alarm	2-97

2.5.115 HIBATVG	2-97
Clear the HIBATVG Alarm	2-97
2.5.116 HI-CCVOLT	2-97
Clear the HI-CCVOLT Condition	2-97
2.5.117 HI-LASERBIAS	2-98
Clear the HI-LASERBIAS Alarm	2-98
2.5.118 HI-LASERTEMP	2-98
Clear the HI-LASERTEMP Alarm	2-99
2.5.119 HI-RXPOWER	2-99
Clear the HI-RXPOWER Alarm	2-100
2.5.120 HITEMP	2-100
Clear the HITEMP Alarm	2-100
2.5.121 HI-TXPOWER	2-101
Clear the HI-TXPOWER Alarm	2-102
2.5.122 HLDVRSYNC	2-102
Clear the HLDVRSYNC Condition	2-102
2.5.123 HP-DEG	2-103
Clear the HP-DEG Condition	2-103
2.5.124 HP-ENCAP-MISMATCH	2-104
Clear the HP-ENCAP-MISMATCH Alarm	2-105
2.5.125 HP-EXC	2-105
Clear the HP-EXC Condition	2-105
2.5.126 HP-PLM	2-106
2.5.127 HP-RFI	2-106
Clear the HP-RFI Condition	2-106
2.5.128 HP-TIM	2-106
Clear the HP-TIM Alarm	2-107
2.5.129 HP-UNEQ	2-107
Clear the HP-UNEQ Alarm	2-107
2.5.130 I-HITEMP	2-109
Clear the I-HITEMP Alarm	2-109
2.5.131 ILK-FAIL	2-109
Clear the ILK-FAIL Alarm	2-109
2.5.132 IMPROPRMVL	2-109
Clear the IMPROPRMVL Alarm	2-110
2.5.133 INHSWPR	2-111
Clear the INHSWPR Condition	2-112
2.5.134 INHSWWKG	2-112
Clear the INHSWWKG Condition	2-112
2.5.135 INCOMPATIBLE-SEND-PDIP	2-112

	Clear the INCOMPATIBLE-SEND-PDIP Alarm	2-113
2.5.136	INCOMPATIBLE-SW	2-113
	Clear the INCOMPATIBLE-SW Alarm	2-113
2.5.137	INTRUSION-PSWD	2-113
	Clear the INTRUSION-PSWD Condition	2-113
2.5.138	INVMACADR	2-114
	Clear the INVMACADR Alarm	2-114
2.5.139	ISIS-ADJ-FAIL	2-116
	Clear the ISIS-ADJ-FAIL Alarm	2-116
2.5.140	LASER-APR	2-117
2.5.141	LASERBIAS-DEG	2-118
	Clear the LASERBIAS-DEG Alarm	2-118
2.5.142	LASERBIAS-FAIL	2-118
	Clear the LASERBIAS-FAIL Alarm	2-119
2.5.143	LASEREOL	2-119
	Clear the LASEREOL Alarm	2-119
2.5.144	LASERTEMP-DEG	2-120
	Clear the LASERTEMP-DEG Alarm	2-120
2.5.145	LMP-FAIL	2-120
	Clear the LMP-FAIL Alarm	2-121
2.5.146	LMP-SD	2-122
	Clear the LMP-SD Condition	2-122
2.5.147	LMP-SF	2-122
	Clear the LMP-SF Condition	2-123
2.5.148	LMP-UNALLOC	2-124
2.5.149	LOCKOUT-REQ	2-124
	Clear the LOCKOUT-REQ Condition	2-125
2.5.150	LOCKOUT-REQ (2R, EQPT, ESCON, FC, GE, ISC)	2-125
	Clear the LOCKOUT-REQ (2R, EQPT, ESCON, FC, GE, ISC) Condition	2-125
2.5.151	LOCKOUT-REQ (TRUNK)	2-125
	Clear the LOCKOUT-REQ (TRUNK) Condition	2-126
2.5.152	LOF (BITS)	2-126
	Clear the LOF (BITS) Alarm	2-126
2.5.153	LOF (TRUNK)	2-127
	Clear the LOF (TRUNK) Alarm	2-127
2.5.154	LOGBUFR90	2-128
2.5.155	LOGBUFROVFL	2-128
	Clear the LOGBUFROVFL Alarm	2-128
2.5.156	LO-LASERBIAS	2-128
	Clear the LO-LASERBIAS Alarm	2-129

- 2.5.157 LO-LASERTEMP 2-129
 - Clear the LO-LASERTEMP Alarm 2-129
- 2.5.158 LOM 2-130
 - Clear the LOM Alarm 2-130
- 2.5.159 LOP-P 2-131
 - Clear the LOP-P Alarm 2-131
- 2.5.160 LO-RXPOWER 2-132
 - Clear the LO-RXPOWER Alarm 2-132
- 2.5.161 LOS (2R) 2-133
 - Clear the LOS (2R) Alarm 2-133
- 2.5.162 LOS (BITS) 2-134
 - Clear the LOS (BITS) Alarm 2-134
- 2.5.163 LOS (ESCON) 2-134
 - Clear the LOS (ESCON) Alarm 2-134
- 2.5.164 LOS (ISC) 2-135
 - Clear the LOS (ISC) Alarm 2-136
- 2.5.165 LOS (OTS) 2-136
 - Clear the LOS (OTS) Alarm 2-136
- 2.5.166 LOS (TRUNK) 2-136
 - Clear the LOS (TRUNK) Alarm 2-137
- 2.5.167 LOS-O 2-138
 - Clear the LOS-O Alarm 2-138
- 2.5.168 LOS-P (AOTS, OMS, OTS) 2-139
 - Clear the LOS-P (AOTS, OMS, OTS) Alarm 2-139
- 2.5.169 LOS-P (OCH) 2-142
 - Clear the LOS-P (OCH) Alarm 2-142
- 2.5.170 LOS-P (TRUNK) 2-145
 - Clear the LOS-P (TRUNK) Alarm 2-146
- 2.5.171 LOS-RAMAN (OTS) 2-147
 - Clear the LOS-RAMAN Condition 2-147
- 2.5.172 LO-TXPOWER 2-148
 - Clear the LO-TXPOWER Alarm 2-149
- 2.5.173 LPBKCRS 2-149
 - Clear the Condition 2-149
- 2.5.174 LPBKFACILITY (ESCON) 2-149
 - Clear the LPBKFACILITY (ESCON) Condition 2-150
- 2.5.175 LPBKFACILITY (FC) 2-150
 - Clear the LPBKFACILITY (FC) Condition 2-150
- 2.5.176 LPBKFACILITY (GE) 2-150
 - Clear the LPBKFACILITY (GE) Condition 2-151

2.5.177 LPBKFACILITY (ISC)	2-151
Clear the LPBKFACILITY (ISC) Condition	2-151
2.5.178 LPBKFACILITY (TRUNK)	2-152
Clear the LPBKFACILITY (TRUNK) Condition	2-152
2.5.179 LPBKTERMINAL (ESCON)	2-152
Clear the LPBKTERMINAL (ESCON) Condition	2-152
2.5.180 LPBKTERMINAL (FC)	2-152
Clear the LPBKTERMINAL (FC) Condition	2-153
2.5.181 LPBKTERMINAL (GE)	2-153
Clear the LPBKTERMINAL (GE) Condition	2-153
2.5.182 LPBKTERMINAL (ISC)	2-154
Clear the LPBKTERMINAL (ISC) Condition	2-154
2.5.183 LPBKTERMINAL (TRUNK)	2-154
Clear the LPBKTERMINAL (TRUNK) Condition	2-154
2.5.184 LWBATVG	2-155
Clear the LWBATVG Alarm	2-155
2.5.185 MAN-REQ	2-155
Clear the MAN-REQ Condition	2-155
2.5.186 MANRESET	2-155
2.5.187 MANSWTOINT	2-156
2.5.188 MANSWTOPRI	2-156
2.5.189 MANSWTOSEC	2-156
2.5.190 MANSWTO THIRD	2-156
2.5.191 MANUAL-REQ-SPAN (2R, ESCON, FC, GE, ISC, OCN/STMN, OTS)	2-156
2.5.192 MANUAL-REQ-SPAN (TRUNK)	2-157
2.5.193 MEA (AIP)	2-157
Clear the MEA (AIP) Alarm	2-157
2.5.194 MEA (EQPT)	2-157
Clear the MEA (EQPT) Alarm	2-158
2.5.195 MEA (FAN)	2-159
Clear the MEA (FAN) Alarm	2-159
2.5.196 MEA (PPM)	2-160
Clear the MEA (PPM) Alarm	2-160
2.5.197 MEA (SHELF)	2-161
Clear the MEA (SHELF) Condition	2-161
2.5.198 MEM-GONE	2-161
2.5.199 MEM-LOW	2-161
2.5.200 MFGMEM	2-162
Clear the MFGMEM Alarm	2-162
2.5.201 MS-AIS	2-163

Clear the MS-AIS Condition	2-163
2.5.202 MS-DEG	2-163
Clear the MS-DEG Condition	2-163
2.5.203 MS-EOC	2-163
Clear the MS-EOC Alarm	2-164
2.5.204 MS-EXC	2-164
Clear the MS-EXC Condition	2-164
2.5.205 MS-RFI	2-164
Clear the MS-RFI Condition	2-165
2.5.206 MT-OCHNC	2-165
Clear the MT-OCHNC Condition	2-165
2.5.207 NON-CISCO-PPM	2-165
Clear the NON-CISCO-PPM Condition	2-165
2.5.208 NOT-AUTHENTICATED	2-166
2.5.209 OCHNC-INC	2-166
Clear the OCHNC-INC Alarm	2-167
2.5.210 OCHTERM-INC	2-167
Clear the OCHTERM-INC Condition	2-167
2.5.211 ODUK-1-AIS-PM	2-167
Clear the ODUK-1-AIS-PM Condition	2-168
2.5.212 ODUK-2-AIS-PM	2-168
Clear the ODUK-2-AIS-PM Condition	2-168
2.5.213 ODUK-3-AIS-PM	2-168
Clear the ODUK-3-AIS-PM Condition	2-168
2.5.214 ODUK-4-AIS-PM	2-169
Clear the ODUK-4-AIS-PM Condition	2-169
2.5.215 ODUK-AIS-PM	2-169
Clear the ODUK-AIS-PM Condition	2-170
2.5.216 ODUK-BDI-PM	2-170
Clear the ODUK-BDI-PM Condition	2-170
2.5.217 ODUK-LCK-PM	2-170
Clear the ODUK-LCK-PM Condition	2-171
2.5.218 ODUK-OCI-PM	2-171
Clear the ODUK-OCI-PM Condition	2-171
2.5.219 ODUK-SD-PM	2-171
Clear the ODUK-SD-PM Condition	2-172
2.5.220 ODUK-SF-PM	2-172
Clear the ODUK-SF-PM Condition	2-172
2.5.221 ODUK-TIM-PM	2-173
Clear the ODUK-TIM-PM Condition	2-173

2.5.222	OPEN-SLOT	2-173	
	Clear the OPEN-SLOT Condition	2-173	
2.5.223	OPTNTWMIS	2-174	
	Clear the OPTNTWMIS Alarm	2-174	
2.5.224	OPWR-HDEG	2-174	
	Clear the OPWR-HDEG Alarm	2-175	
2.5.225	OPWR-HFAIL	2-176	
	Clear the OPWR-HFAIL Alarm	2-177	
2.5.226	OPWR-LDEG	2-177	
	Clear the OPWR-LDEG Alarm	2-177	
2.5.227	OPWR-LFAIL	2-178	
	Clear the OPWR-LFAIL Alarm	2-178	
2.5.228	OSRION	2-178	
	Clear the OSRION Condition	2-179	
2.5.229	OTUK-AIS	2-179	
	Clear the OTUK-AIS Condition	2-179	
2.5.230	OTUK-BDI	2-179	
	Clear the OTUK-BDI Condition	2-180	
2.5.231	OTUK-IAE	2-180	
	Clear the OTUK-IAE Alarm	2-181	
2.5.232	OTUK-LOF	2-181	
	Clear the OTUK-LOF Alarm	2-182	
2.5.233	OTUK-SD	2-182	
	Clear the OTUK-SD Condition	2-183	
2.5.234	OTUK-SF	2-183	
	Clear the OTUK-SF Condition	2-184	
2.5.235	OTUK-TIM	2-184	
	Clear the OTUK-TIM Condition	2-184	
2.5.236	OUT-OF-SYNC	2-184	
	Clear the OUT-OF-SYNC Condition	2-185	
2.5.237	PARAM-MISM	2-185	
2.5.238	PDI-P	2-186	
	Clear the PDI-P Condition	2-187	
2.5.239	PEER-NORESPONSE	2-187	
	Clear the PEER-NORESPONSE Alarm	2-188	
2.5.240	PMI	2-188	
	Clear the PMI Condition	2-188	
2.5.241	PORT-FAIL	2-189	
	Clear the PORT-FAIL Alarm	2-189	
2.5.242	PROTNA	2-189	

Clear the PROTNA Alarm	2-190
2.5.243 PROV-MISMATCH	2-190
Clear the PROV-MISMATCH Alarm	2-191
2.5.244 PTIM	2-192
Clear the PTIM Alarm	2-192
2.5.245 PWR-FAIL-A	2-192
Clear the PWR-FAIL-A Alarm	2-193
2.5.246 PWR-FAIL-B	2-193
Clear the PWR-FAIL-B Alarm	2-194
2.5.247 PWR-FAIL-RET-A	2-194
Clear the PWR-FAIL-RET-A Alarm	2-194
2.5.248 PWR-FAIL-RET-B	2-194
Clear the PWR-FAIL-RET-A Alarm	2-195
2.5.249 PWR-PROT-ON	2-195
Clear the PWR-PROT-ON Alarm	2-195
2.5.250 RFI	2-195
Clear the RFI Condition	2-196
2.5.251 RFI-L	2-196
Clear the RFI-L Condition	2-196
2.5.252 RFI-P	2-196
Clear the RFI-P Condition	2-196
2.5.253 RLS	2-197
Clear the RLS Condition	2-197
2.5.254 ROUTE-OVERFLOW	2-197
Clear the ROUTE-OVERFLOW Condition	2-198
2.5.255 RS-EOC	2-198
Clear the RS-EOC Alarm	2-199
2.5.256 RS-TIM	2-200
Clear the RS-TIM Alarm	2-200
2.5.257 SD (TRUNK)	2-201
Clear the SD (TRUNK) Condition	2-201
2.5.258 SD-L	2-201
Clear the SD-L Condition	2-202
2.5.259 SD-L (TRUNK)	2-202
Clear the SD-L (TRUNK) Condition	2-202
2.5.260 SD-P	2-202
Clear the SD-P Condition	2-203
2.5.261 SDBER-EXCEED-HO	2-203
Clear the SDBER-EXCEED-HO Condition	2-203
2.5.262 SF (TRUNK)	2-204

Clear the SF (TRUNK) Condition	2-204
2.5.263 SF-L	2-205
Clear the SF-L Condition	2-205
2.5.264 SF-L (TRUNK)	2-205
Clear the SF-L (TRUNK) Condition	2-205
2.5.265 SF-P	2-206
Clear the SF-P Condition	2-206
2.5.266 SFTWDOWN	2-206
2.5.267 SHELF-COMM-FAIL	2-206
Clear the SHELF-COMM-FAIL Alarm	2-207
2.5.268 SH-IL-VAR-DEG-HIGH	2-207
Clear the SH-IL-VAR-DEG-HIGH Alarm	2-207
2.5.269 SH-IL-VAR-DEG-LOW	2-207
Clear the SH-IL-VAR-DEG-LOW Alarm	2-208
2.5.270 SHUTTER-OPEN	2-208
Clear the SHUTTER-OPEN Condition	2-208
2.5.271 SIGLOSS	2-208
Clear the SIGLOSS Alarm	2-209
2.5.272 SNTP-HOST	2-209
Clear the SNTP-HOST Alarm	2-209
2.5.273 SPANLEN-OUT-OF-RANGE	2-210
Clear the SPANLEN-OUT-OF-RANGE Alarm	2-210
2.5.274 SPAN-NOT-MEASURED	2-210
2.5.275 SQUELCHED	2-210
Clear the SQUELCHED Condition	2-212
2.5.276 SSM-DUS	2-212
2.5.277 SSM-FAIL	2-213
Clear the SSM-FAIL Alarm	2-213
2.5.278 SSM-LNC	2-213
2.5.279 SSM-OFF	2-213
Clear the SSM-OFF Condition	2-214
2.5.280 SSM-PRC	2-214
2.5.281 SSM-PRS	2-214
2.5.282 SSM-RES	2-214
2.5.283 SSM-SMC	2-214
2.5.284 SSM-ST2	2-215
2.5.285 SSM-ST3	2-215
2.5.286 SSM-ST3E	2-215
2.5.287 SSM-ST4	2-215
2.5.288 SSM-STU	2-216

Clear the SSM-STU Condition	2-216
2.5.289 SSM-TNC	2-216
2.5.290 SW-MISMATCH	2-216
Clear the SW-MISMATCH Condition	2-217
2.5.291 SWTOPRI	2-217
2.5.292 SWTOSEC	2-217
Clear the SWTOSEC Condition	2-217
2.5.293 SWTOTHIRD	2-217
Clear the SWTOTHIRD Condition	2-218
2.5.294 SYNC-FREQ	2-218
Clear the SYNC-FREQ Condition	2-218
2.5.295 SYNCLOSS	2-218
Clear the SYNCLOSS Alarm	2-219
2.5.296 SYNCPRI	2-219
Clear the SYNCPRI Alarm	2-219
2.5.297 SYNCSEC	2-220
Clear the SYNCSEC Alarm	2-220
2.5.298 SYNCTHIRD	2-220
Clear the SYNCTHIRD Alarm	2-220
2.5.299 SYSBOOT	2-221
2.5.300 TEMP-MISM	2-221
Clear the TEMP-MISM Condition	2-222
2.5.301 TIM	2-222
Clear the TIM Alarm	2-222
2.5.302 TIM-MON	2-223
Clear the TIM-MON Alarm	2-223
2.5.303 TIM-P	2-223
Clear the TIM-P Alarm	2-224
2.5.304 TIM-S	2-224
Clear the TIM-S Alarm	2-224
2.5.305 TRAIL-SIGNAL-FAIL	2-225
Clear the TRAIL-SIGNAL-FAIL Condition	2-225
2.5.306 UNC-WORD	2-225
Clear the UNC-WORD Condition	2-225
2.5.307 UNEQ-P	2-226
Clear the UNEQ-P Alarm	2-226
2.5.308 UNQUAL-PPM	2-228
Clear the UNQUAL-PPM Condition	2-228
2.5.309 UNREACHABLE-TARGET-POWER	2-228
2.5.310 UT-COMM-FAIL	2-228

- Clear the UT-COMM-FAIL Alarm 2-229
 - 2.5.311 UT-FAIL 2-229
 - Clear the UT-FAIL Alarm 2-229
 - 2.5.312 VOA-DISABLED 2-229
 - Clear the VOA-DISABLED Condition 2-229
 - 2.5.313 VOA-HDEG 2-230
 - Clear the VOA-HDEG Alarm 2-230
 - 2.5.314 VOA-HFAIL 2-230
 - Clear the VOA-HFAIL Alarm 2-230
 - 2.5.315 VOA-LDEG 2-231
 - Clear the VOA-LDEG Alarm 2-231
 - 2.5.316 VOA-LFAIL 2-231
 - Clear the VOA-LFAIL Alarm 2-231
 - 2.5.317 VOLT-MISM 2-232
 - Clear the VOLT-MISM Condition 2-232
 - 2.5.318 WKSWPR (2R, EQPT, ESCON, FC, GE, ISC, OTS) 2-232
 - 2.5.319 WKSWPR (TRUNK) 2-232
 - 2.5.320 WTR (2R, ESCON, FC, GE, ISC) 2-233
 - 2.5.321 WTR (TRUNK) 2-233
 - 2.5.322 WVLMISMATCH 2-233
 - Clear the WVLMISMATCH alarm 2-233
- 2.6 DWDM Card LED Activity 2-234
 - 2.6.1 DWDM Card LED Activity After Insertion 2-234
 - 2.6.2 DWDM Card LED Activity During Reset 2-234
- 2.7 Traffic Card LED Activity 2-235
 - 2.7.1 Typical Traffic Card LED Activity After Insertion 2-235
 - 2.7.2 Typical Traffic Card LED Activity During Reset 2-235
 - 2.7.3 Typical Card LED State After Successful Reset 2-235
- 2.8 Frequently Used Alarm Troubleshooting Procedures 2-236
 - 2.8.1 Node and Ring Identification, Change, Visibility, and Termination 2-236
 - Identify a BLSR Ring Name or Node ID Number 2-236
 - Change a BLSR Ring Name 2-236
 - Change a BLSR Node ID Number 2-236
 - Verify Node Visibility for Other Nodes 2-237
 - 2.8.2 Protection Switching, Lock Initiation, and Clearing 2-237
 - Initiate a 1+1 Protection Port Force Switch Command 2-237
 - Initiate a 1+1 Manual Switch Command 2-237
 - Initiate a 1:1 Card Switch Command 2-238
 - Clear a 1+1 Force or Manual Switch Command 2-238

Initiate a Lock-On Command	2-239
Initiate a Card or Port Lockout Command	2-239
Clear a Lock-On or Lockout Command	2-240
Initiate a Lockout on a BLSR Protect Span	2-240
Clear a BLSR External Switching Command	2-240
2.8.3 CTC Card Resetting and Switching	2-241
Reset a Card in CTC	2-241
Reset an Active TCC2/TCC2P Card and Activate the Standby Card	2-241
2.8.4 Physical Card Reseating, Resetting, and Replacement	2-242
Remove and Reinsert (Reseat) the Standby TCC2/TCC2P Card	2-242
Remove and Reinsert (Reseat) Any Card	2-243
Physically Replace a Card	2-244
2.8.5 Generic Signal and Circuit Procedures	2-244
Verify the Signal BER Threshold Level	2-244
Delete a Circuit	2-245
Verify or Create Node Section DCC Terminations	2-245
Clear an MXP, TXP, GE-XP, 10GE-XP, and ADM-10G Card Loopback Circuit	2-245
Verify or Create Node RS-DCC Terminations	2-246
Clear an STM-N Card XC Loopback Circuit	2-246
2.8.6 Air Filter and Fan Procedures	2-246
Inspect, Clean, and Replace the Reusable Air Filter	2-247
Remove and Reinsert a Fan-Tray Assembly	2-248
Replace the Fan-Tray Assembly	2-249
2.8.7 Interface Procedures	2-250
Replace the Alarm Interface Panel	2-250

CHAPTER 3**Transient Conditions 3-1**

3.1 Transients Indexed By Alphabetical Entry	3-1
3.2 Trouble Notifications	3-3
3.2.1 Condition Characteristics	3-3
3.2.2 Condition States	3-3
3.3 Transient Conditions	3-4
3.3.1 ADMIN-DISABLE	3-4
3.3.2 ADMIN-DISABLE-CLR	3-4
3.3.3 ADMIN-LOCKOUT	3-4
3.3.4 ADMIN-LOCKOUT-CLR	3-4
3.3.5 ADMIN-LOGOUT	3-4
3.3.6 ADMIN-SUSPEND	3-4
3.3.7 ADMIN-SUSPEND-CLR	3-5

3.3.8	AUD-ARCHIVE-FAIL	3-5
3.3.9	AUTOWDMANS	3-5
3.3.10	BLSR-RESYNC	3-5
3.3.11	DBBACKUP-FAIL	3-5
3.3.12	DBRESTORE-FAIL	3-5
3.3.13	EXERCISING-RING	3-6
3.3.14	EXERCISING-SPAN	3-6
3.3.15	FIREWALL-DIS	3-6
3.3.16	FRCDWKSWBK-NO-TRFSW	3-6
3.3.17	FRCDWKSWPR-NO-TRFSW	3-6
3.3.18	INTRUSION	3-6
3.3.19	INTRUSION-PSWD	3-7
3.3.20	IOSCFG-COPY-FAIL	3-7
3.3.21	LOGIN-FAIL-LOCKOUT	3-7
3.3.22	LOGIN-FAIL-ONALRDY	3-7
3.3.23	LOGIN-FAILURE-PSWD	3-7
3.3.24	LOGIN-FAILURE-USERID	3-7
3.3.25	LOGOUT-IDLE-USER	3-8
3.3.26	MANWKSWBK-NO-TRFSW	3-8
3.3.27	MANWKSWPR-NO-TRFSW	3-8
3.3.28	MCAST-MAC-ALIASING	3-8
3.3.29	MSSP-RESYNC	3-8
3.3.30	PM-TCA	3-8
3.3.31	PS	3-8
3.3.32	RMON-ALARM	3-9
3.3.33	RMON-RESET	3-9
3.3.34	SESSION-TIME-LIMIT	3-9
3.3.35	SFTWDOWN-FAIL	3-9
3.3.36	SPAN-NOT-MEASURED	3-9
3.3.37	SWFTDOWNFAIL	3-9
3.3.38	USER-LOCKOUT	3-9
3.3.39	USER-LOGIN	3-10
3.3.40	USER-LOGOUT	3-10
3.3.41	WKSWBK	3-10
3.3.42	WKSWPR	3-10
3.3.43	WRMRESTART	3-10
3.3.44	WTR-SPAN	3-10

CHAPTER 4 **Error Messages** 4-1

INDEX



FIGURES

<i>Figure 1-1</i>	Facility Loopback Path on a Near-End Transponder Card	1-3
<i>Figure 1-2</i>	Terminal Loopback on a TXP Card	1-5
<i>Figure 1-3</i>	Facility Loopback on a Circuit Source MXP or TXP Port	1-9
<i>Figure 1-4</i>	Terminal Loopback on a Source-Node MXP or TXP Port	1-12
<i>Figure 1-5</i>	Facility Loopback on an Intermediate-Node MXP or TXP Port	1-15
<i>Figure 1-6</i>	Terminal Loopback on an Intermediate-Node MXP or TXP Port	1-17
<i>Figure 1-7</i>	Facility Loopback on a Destination-Node MXP or TXP Port	1-20
<i>Figure 1-8</i>	Terminal Loopback on a Destination-Node MXP or TXP Port	1-22
<i>Figure 1-9</i>	Optical Transport Network Layers	1-25
<i>Figure 1-10</i>	Performance Monitoring Points on ONS DWDM	1-27
<i>Figure 1-11</i>	Set Default BBE/SES Card Thresholds	1-28
<i>Figure 1-12</i>	Provision Card BBE/SES Thresholds	1-29
<i>Figure 1-13</i>	Provision Optical TCA Thresholds	1-30
<i>Figure 1-14</i>	Provision Card FEC Thresholds	1-31
<i>Figure 1-15</i>	ONS 15454 Node View Diagnostic Window	1-34
<i>Figure 1-16</i>	DCN Tools OSPF Dump	1-37
<i>Figure 1-17</i>	Deleting the CTC Cache	1-49
<i>Figure 1-18</i>	RJ-45 Pin Numbers	1-57
<i>Figure 1-19</i>	LAN Cable Layout	1-57
<i>Figure 1-20</i>	Cross-Over Cable Layout	1-58
<i>Figure 1-21</i>	Linear Network, With No Fiber Cut	1-62
<i>Figure 1-22</i>	Fiber Cut with ALS MODE = Auto Restart	1-63
<i>Figure 1-23</i>	LOS Indication on the ROADM Node OSC-CSM	1-64
<i>Figure 1-24</i>	LOS Indication on the OLA Node OPT-BST	1-65
<i>Figure 1-25</i>	Network View Fault Condition for Fiber Cut with ALS Mode Disabled	1-66
<i>Figure 1-26</i>	ONS 15454 SDH ROADM Node View with Fault Condition for ALS MODE Disabled	1-67
<i>Figure 1-27</i>	ONS 15454 SDH OLA Node View with Fault Condition for ALS MODE Disabled	1-68
<i>Figure 1-28</i>	Network View for Span Loss Change > 5 dBm and OSC Power Value at Receiver > -42 dBm	1-73
<i>Figure 1-29</i>	OCHNC Circuit Successfully Completed	1-81
<i>Figure 1-30</i>	Partial Circuit	1-82

<i>Figure 1-31</i>	Circuit Discovered, State OSS	1-83
<i>Figure 1-32</i>	VOA Startup Procedure	1-86
<i>Figure 1-33</i>	LOS-P Indication on the VOA Port	1-88
<i>Figure 1-34</i>	Power Level of Incoming Signal Less than -33 dBm	1-93
<i>Figure 1-35</i>	Optical Power Less than 6 dB Lower than Expected	1-94
<i>Figure 1-36</i>	Optical Drop Power More than 6 dB Lower than Expected	1-101
<i>Figure 1-37</i>	Optical Drop Power Less than 6 dB Lower than Expected	1-102
<i>Figure 2-1</i>	Shelf LCD Panel	2-40
<i>Figure 2-2</i>	Shelf LCD Panel	2-101
<i>Figure 4-1</i>	Error Dialog Box	4-1



T A B L E S

<i>Table 1-1</i>	DWDM Card Facility Loopback Behavior	1-4
<i>Table 1-2</i>	DWDM Card Terminal Loopback Behavior	1-6
<i>Table 1-3</i>	Diagnostic Files Retrieved Based on User Privilege	1-35
<i>Table 1-4</i>	List of Diagnostic Files	1-36
<i>Table 1-5</i>	Slow CTC Operation or Login Problems	1-48
<i>Table 1-6</i>	JRE Compatibility	1-50
<i>Table 1-7</i>	LAN Cable Pinout	1-57
<i>Table 1-8</i>	Cross-Over Cable Pinout	1-58
<i>Table 2-1</i>	Critical DWDM Alarm List	2-2
<i>Table 2-2</i>	Major DWDM Alarm List	2-3
<i>Table 2-3</i>	Minor DWDM Alarm List	2-3
<i>Table 2-4</i>	NA DWDM Conditions List	2-5
<i>Table 2-5</i>	NR DWDM Conditions List	2-8
<i>Table 2-6</i>	Alphabetical DWDM Alarm and Condition List	2-8
<i>Table 2-7</i>	Alarm Logical Object Type Definitions	2-14
<i>Table 2-8</i>	Alarm List by Logical Object in Alarm Profile	2-17
<i>Table 2-9</i>	Transponder Trunk Alarms that Cause LMP-SD	2-122
<i>Table 2-10</i>	Transponder Client Alarm that Causes LMP-SD	2-122
<i>Table 2-11</i>	Transponder Card Alarms that Cause LMP-SF	2-123
<i>Table 2-12</i>	Transponder Trunk Alarms that Cause LMP-SF	2-123
<i>Table 2-13</i>	Transponder Client Alarms that Cause LMP-SF	2-123
<i>Table 3-1</i>	ONS 15454 Transient Condition Alphabetical Index	3-1
<i>Table 4-1</i>	Error Messages	4-2



Preface



Note

The terms "Unidirectional Path Switched Ring" and "UPSR" may appear in Cisco literature. These terms do not refer to using Cisco ONS 15xxx products in a unidirectional path switched ring configuration. Rather, these terms, as well as "Path Protected Mesh Network" and "PPMN," refer generally to Cisco's path protection feature, which may be used in any topological network configuration. Cisco does not recommend using its path protection feature in any particular topological network configuration.

This section explains the objectives, intended audience, and organization of this publication and describes the conventions that convey instructions and other information.

This section provides the following information:

- [Document Objectives](#)
- [Audience](#)
- [Document Organization](#)
- [Related Documentation](#)
- [Document Conventions](#)
- [Obtaining Optical Networking Information](#)
- [Obtaining Documentation and Submitting a Service Request](#)

Revision History

Date	Notes
November 2008	<ul style="list-style-type: none">• Updated Alarm Severity for SYNCPRI in Chapter 2, Alarm Troubleshooting.• Added ADM-10G alarms in Chapter 2, Alarm Troubleshooting.
March 2009	<ul style="list-style-type: none">• Deleted references to the ADD-OPWR-HDEG, ADD-OPWR-LDEG, ADD-OPWR-HFAIL, and ADD-OPWR-LFAIL Alarms in Chapter 2, Alarm Troubleshooting.
May 2009	<ul style="list-style-type: none">• Updated PWR-FAIL-A, PWR-FAIL-B, PWR-FAIL-RET-A, and PWR-FAIL-RET-B alarm details in Chapter 2, Alarm Troubleshooting.
June 2009	<ul style="list-style-type: none">• Updated client and trunk port details for ADM-10G card in Table 1-1 and Table 1-2 of Chapter 1, General Troubleshooting.

Date	Notes
July 2009	<ul style="list-style-type: none"> • Added a note under the “OPWR-LDEG” alarm in Chapter 2, “Alarm Troubleshooting”.
August 2009	<ul style="list-style-type: none"> • Added the description and the procedure to clear the “APC-WRONG-GAIN” condition in Chapter 2, “Alarm Troubleshooting”. • Updated MEM-GONE alarm description in Chapter 2, Alarm Troubleshooting.
November 2009	<ul style="list-style-type: none"> • Updated the section “Isolate the Cause of Power Supply Problems” in the chapter, “General Troubleshooting”.
January 2010	<ul style="list-style-type: none"> • Updated the “Alarm Troubleshooting” chapter with four new alarms: SD-L (TRUNK), SF-L (TRUNK), MEA (SHELF), and UNREACHABLE-TARGET-POWER.
February 2010	<ul style="list-style-type: none"> • Changed the BIEC parameter to BIT-EC in Chapter 1, “General Troubleshooting”.
March 2010	<ul style="list-style-type: none"> • Added content to the AS-MT alarm in Chapter 2, “General Troubleshooting”.
June 2010	<ul style="list-style-type: none"> • Updated the table “Alarm Logical Object Type Definitions” in the chapter “Alarm Troubleshooting”. • Updated the description of the PWR-FAIL-A and PWR-FAIL-B alarms in the chapter, Alarm Troubleshooting.
July 2010	Updated the “Error Messages” table in the chapter “Error Messages”.
January 2011	Updated the section “FAPS-CONFIG-MISMATCH” in the chapter “Alarm Troubleshooting”.
April 2011	Updated the section “LOS-P (AOTS, OMS, OTS)” in the chapter “Alarm Troubleshooting”.
September 2011	Updated the “Facility Loopbacks” section in the chapter, “General Troubleshooting”.
November 2011	Updated the section “PROV-MISMATCH” in the chapter “Alarm Troubleshooting”.
January 2012	Updated the section “SPANLENGTH-OUT-OF-RANGE” in the chapter, “Alarm Troubleshooting”.
February 2012	<ul style="list-style-type: none"> • Updated the section “RLS” in the chapter, “Alarm Troubleshooting”. • Updated the section “IMPROPRMVL” in the chapter “Alarm Troubleshooting”.
May 2012	Updated the section “Clear the UNC-WORD Condition” in the chapter “Alarm Troubleshooting”.
June 2012	Document Part Number revisioned to 78-18378-02 and a full length book-PDF was generated.

Document Objectives

This guide gives troubleshooting information and troubleshooting-related parameters for the Cisco ONS 15454 (ANSI) and Cisco ONS 15454 SDH (ETSI) platforms, specifically the dense wavelength division multiplexing (DWDM) application that can operate on either platform. Use this guide in conjunction with the appropriate publications listed in the [Related Documentation](#) section.

Audience

To use this publication, you should be familiar with Cisco or equivalent optical transmission hardware and cabling, telecommunications hardware and cabling, electronic circuitry and wiring practices, and preferably have experience as a telecommunications technician.

Document Organization

Table 1 *Cisco ONS 15454 Procedure Guide Chapters*

Title	Summary
Chapter 1, “General Troubleshooting”	Provides procedures for troubleshooting the most common problems encountered when operating a Cisco ONS 15454 DWDM shelf in ANSI or ETSI platforms.
Chapter 2, “Alarm Troubleshooting”	Gives a description, severity, and troubleshooting procedure for each commonly encountered Cisco DWDM alarm and condition.
Chapter 4, “Error Messages”	Lists the error messages for the Cisco ONS 15454 Multi-Service Transport Platform (MSTP).
Chapter 3, “Transient Conditions”	Gives a description, entity, Simple Network Management Protocol (SNMP) number, and trap for each commonly encountered Cisco ONS 15454 transient condition.

Related Documentation

Use the *Cisco ONS 15454 DWDM Troubleshooting Guide* in conjunction with the following publications:

- *Cisco ONS 15454 DWDM Procedure Guide*
Provides procedures to install, turn up, test, and maintain an ONS 15454 DWDM node and network.
- *Cisco ONS 15454 DWDM Reference Manual*
Provides card, node, and network reference information, including performance monitoring parameters and network element defaults.
- *Cisco ONS SONET TL1 Command Guide*
Provides a full TL1 command and autonomous message set including parameters, AIDs, conditions and modifiers for the Cisco ONS 15454, ONS 15600, ONS 15310-CL, and ONS 15310-MA systems.
- *Cisco ONS SONET TL1 Reference Guide*
Provides general information, procedures, and errors for TL1 in the Cisco ONS 15454, ONS 15327, ONS 15600, ONS 15310-CL, and ONS 15310-MA systems.
- *Cisco ONS 15454 SDH and Cisco ONS 15600 SDH TL1 Command Guide*
Provides a full TL1 command and autonomous message set including parameters, AIDs, conditions and modifiers for the Cisco ONS 15454 SDH and Cisco ONS 15600 SDH.

- *Cisco ONS 15454 SDH and Cisco ONS 15600 SDH TL1 Reference Guide*
Provides general information, procedures, and errors for TL1 in the Cisco ONS 15454 SDH and Cisco ONS 15600 SDH.
- *Release Notes for the Cisco ONS 15454 Release 9.0*
Provides caveats, closed issues, and new feature and functionality information.
- *Release Notes for the Cisco ONS 15454 SDH Release 9.0*
Provides caveats, closed issues, and new feature and functionality information.

Refer to the following standards documentation referenced in this publication:

- Telcordia GR-253 CORE

Document Conventions

This publication uses the following conventions:

Convention	Application
boldface	Commands and keywords in body text.
<i>italic</i>	Command input that is supplied by the user.
[]	Keywords or arguments that appear within square brackets are optional.
{ x x x }	A choice of keywords (represented by x) appears in braces separated by vertical bars. The user must select one.
Ctrl	The control key. For example, where Ctrl + D is written, hold down the Control key while pressing the D key.
screen font	Examples of information displayed on the screen.
boldface screen font	Examples of information that the user must enter.
< >	Command parameters that must be replaced by module-specific codes.



Note

Means *reader take note*. Notes contain helpful suggestions or references to material not covered in the document.



Caution

Means *reader be careful*. In this situation, the user might do something that could result in equipment damage or loss of data.



Warning

IMPORTANT SAFETY INSTRUCTIONS

This warning symbol means danger. You are in a situation that could cause bodily injury. Before you work on any equipment, be aware of the hazards involved with electrical circuitry and be familiar with standard practices for preventing accidents. Use the statement number provided at the end of each warning to locate its translation in the translated safety warnings that accompanied this device. Statement 1071

SAVE THESE INSTRUCTIONS

Waarschuwing

BELANGRIJKE VEILIGHEIDSINSTRUCTIES

Dit waarschuwingssymbool betekent gevaar. U verkeert in een situatie die lichamelijk letsel kan veroorzaken. Voordat u aan enige apparatuur gaat werken, dient u zich bewust te zijn van de bij elektrische schakelingen betrokken risico's en dient u op de hoogte te zijn van de standaard praktijken om ongelukken te voorkomen. Gebruik het nummer van de verklaring onderaan de waarschuwing als u een vertaling van de waarschuwing die bij het apparaat wordt geleverd, wilt raadplegen.

BEWAAR DEZE INSTRUCTIES

Varoitus

TÄRKEITÄ TURVALLISUUSOHJEITA

Tämä varoitusmerkki merkitsee vaaraa. Tilanne voi aiheuttaa ruumiillisia vammoja. Ennen kuin käsittelet laitteistoa, huomioi sähköpiirien käsittelyyn liittyvät riskit ja tutustu onnettomuuksien yleisiin ehkäisytapoihin. Turvallisuusvaroitusten käännökset löytyvät laitteen mukana toimitettujen käännettyjen turvallisuusvaroitusten joukosta varoitusten lopussa näkyvien lausuntonumeroiden avulla.

SÄILYTÄ NÄMÄ OHJEET

Attention

IMPORTANTES INFORMATIONS DE SÉCURITÉ

Ce symbole d'avertissement indique un danger. Vous vous trouvez dans une situation pouvant entraîner des blessures ou des dommages corporels. Avant de travailler sur un équipement, soyez conscient des dangers liés aux circuits électriques et familiarisez-vous avec les procédures couramment utilisées pour éviter les accidents. Pour prendre connaissance des traductions des avertissements figurant dans les consignes de sécurité traduites qui accompagnent cet appareil, référez-vous au numéro de l'instruction situé à la fin de chaque avertissement.

CONSERVEZ CES INFORMATIONS

Warnung

WICHTIGE SICHERHEITSHINWEISE

Dieses Warnsymbol bedeutet Gefahr. Sie befinden sich in einer Situation, die zu Verletzungen führen kann. Machen Sie sich vor der Arbeit mit Geräten mit den Gefahren elektrischer Schaltungen und den üblichen Verfahren zur Vorbeugung vor Unfällen vertraut. Suchen Sie mit der am Ende jeder Warnung angegebenen Anweisungsnummer nach der jeweiligen Übersetzung in den übersetzten Sicherheitshinweisen, die zusammen mit diesem Gerät ausgeliefert wurden.

BEWAHREN SIE DIESE HINWEISE GUT AUF.

Avvertenza IMPORTANTI ISTRUZIONI SULLA SICUREZZA

Questo simbolo di avvertenza indica un pericolo. La situazione potrebbe causare infortuni alle persone. Prima di intervenire su qualsiasi apparecchiatura, occorre essere al corrente dei pericoli relativi ai circuiti elettrici e conoscere le procedure standard per la prevenzione di incidenti. Utilizzare il numero di istruzione presente alla fine di ciascuna avvertenza per individuare le traduzioni delle avvertenze riportate in questo documento.

CONSERVARE QUESTE ISTRUZIONI**Advarsel VIKTIGE SIKKERHETSINSTRUKSJONER**

Dette advarselssymbolet betyr fare. Du er i en situasjon som kan føre til skade på person. Før du begynner å arbeide med noe av utstyret, må du være oppmerksom på farene forbundet med elektriske kretser, og kjenne til standardprosedyrer for å forhindre ulykker. Bruk nummeret i slutten av hver advarsel for å finne oversettelsen i de oversatte sikkerhetsadvarslene som fulgte med denne enheten.

TA VARE PÅ DISSE INSTRUKSJONENE**Aviso INSTRUÇÕES IMPORTANTES DE SEGURANÇA**

Este símbolo de aviso significa perigo. Você está em uma situação que poderá ser causadora de lesões corporais. Antes de iniciar a utilização de qualquer equipamento, tenha conhecimento dos perigos envolvidos no manuseio de circuitos elétricos e familiarize-se com as práticas habituais de prevenção de acidentes. Utilize o número da instrução fornecido ao final de cada aviso para localizar sua tradução nos avisos de segurança traduzidos que acompanham este dispositivo.

GUARDE ESTAS INSTRUÇÕES**¡Advertencia! INSTRUCCIONES IMPORTANTES DE SEGURIDAD**

Este símbolo de aviso indica peligro. Existe riesgo para su integridad física. Antes de manipular cualquier equipo, considere los riesgos de la corriente eléctrica y familiarícese con los procedimientos estándar de prevención de accidentes. Al final de cada advertencia encontrará el número que le ayudará a encontrar el texto traducido en el apartado de traducciones que acompaña a este dispositivo.

GUARDE ESTAS INSTRUCCIONES**Varning! VIKTIGA SÄKERHETSANVISNINGAR**

Denna varningssignal signalerar fara. Du befinner dig i en situation som kan leda till personskada. Innan du utför arbete på någon utrustning måste du vara medveten om farorna med elkretsar och känna till vanliga förfaranden för att förebygga olyckor. Använd det nummer som finns i slutet av varje varning för att hitta dess översättning i de översatta säkerhetsvarningar som medföljer denna anordning.

SPARA DESSA ANVISNINGAR

FONTOS BIZTONSÁGI ELOÍRÁSOK

Ez a figyelmeztető jel veszélyre utal. Sérülésveszélyt rejtő helyzetben van. Mielőtt bármely berendezésen munkát végezte, legyen figyelemmel az elektromos áramkörök okozta kockázatokra, és ismerkedjen meg a szokásos balesetvédelmi eljárásokkal. A kiadványban szereplő figyelmeztetések fordítása a készülékhez mellékelt biztonsági figyelmeztetések között található; a fordítás az egyes figyelmeztetések végén látható szám alapján kereshető meg.

ORIZZE MEG EZEKET AZ UTASÍTÁSOKAT!

Предупреждение

ВАЖНЫЕ ИНСТРУКЦИИ ПО СОБЛЮДЕНИЮ ТЕХНИКИ БЕЗОПАСНОСТИ

Этот символ предупреждения обозначает опасность. То есть имеет место ситуация, в которой следует опасаться телесных повреждений. Перед эксплуатацией оборудования выясните, каким опасностям может подвергаться пользователь при использовании электрических цепей, и ознакомьтесь с правилами техники безопасности для предотвращения возможных несчастных случаев. Воспользуйтесь номером заявления, приведенным в конце каждого предупреждения, чтобы найти его переведенный вариант в переводе предупреждений по безопасности, прилагаемом к данному устройству.

СОХРАНИТЕ ЭТИ ИНСТРУКЦИИ

警告

重要的安全性说明

此警告符号代表危险。您正处于可能受到严重伤害的工作环境中。在您使用设备开始工作之前，必须充分意识到触电的危险，并熟练掌握防止事故发生的标准工作程序。请根据每项警告结尾提供的声明号码来找到此设备的安全性警告说明的翻译文本。

请保存这些安全性说明

警告

安全上の重要な注意事項

「危険」の意味です。人身事故を予防するための注意事項が記述されています。装置の取り扱い作業を行うときは、電気回路の危険性に注意し、一般的な事故防止策に留意してください。警告の各国語版は、各注意事項の番号を基に、装置に付属の「Translated Safety Warnings」を参照してください。

これらの注意事項を保管しておいてください。

주의

중요 안전 지침

이 경고 기호는 위험을 나타냅니다. 작업자가 신체 부상을 일으킬 수 있는 위험한 환경에 있습니다. 장비에 작업을 수행하기 전에 전기 회로와 관련된 위험을 숙지하고 표준 작업 관례를 숙지하여 사고를 방지하십시오. 각 경고의 마지막 부분에 있는 경고문 번호를 참조하여 이 장치와 함께 제공되는 번역된 안전 경고문에서 해당 번역문을 찾으십시오.

이 지시 사항을 보관하십시오.

Aviso INSTRUÇÕES IMPORTANTES DE SEGURANÇA

Este símbolo de aviso significa perigo. Você se encontra em uma situação em que há risco de lesões corporais. Antes de trabalhar com qualquer equipamento, esteja ciente dos riscos que envolvem os circuitos elétricos e familiarize-se com as práticas padrão de prevenção de acidentes. Use o número da declaração fornecido ao final de cada aviso para localizar sua tradução nos avisos de segurança traduzidos que acompanham o dispositivo.

GUARDE ESTAS INSTRUÇÕES**Advarsel VIGTIGE SIKKERHEDSANVISNINGER**

Dette advarselssymbol betyder fare. Du befinder dig i en situation med risiko for legemeskade. Før du begynder arbejde på udstyr, skal du være opmærksom på de involverede risici, der er ved elektriske kredsløb, og du skal sætte dig ind i standardprocedurer til undgåelse af ulykker. Brug erklæringsnummeret efter hver advarsel for at finde oversættelsen i de oversatte advarsler, der fulgte med denne enhed.

GEM DISSE ANVISNINGER

تحذير

إرشادات الأمان الهامة

يوضح رمز التحذير هذا وجود خطر. وهذا يعني أنك متواجد في مكان قد ينتج عنه التعرض لإصابات. قبل بدء العمل، احذر مخاطر التعرض للصدمات الكهربائية وكن على علم بالإجراءات القياسية للحيلولة دون وقوع أي حوادث. استخدم رقم البيان الموجود في آخر كل تحذير لتحديد مكان ترجمته داخل تحذيرات الأمان المترجمة التي تأتي مع الجهاز. قم بحفظ هذه الإرشادات

Upozorenje VAŽNE SIGURNOSNE NAPOMENE

Ovaj simbol upozorenja predstavlja opasnost. Nalazite se u situaciji koja može prouzročiti tjelesne ozljede. Prije rada s bilo kojim uređajem, morate razumjeti opasnosti vezane uz električne sklopove, te biti upoznati sa standardnim načinima izbjegavanja nesreća. U prevedenim sigurnosnim upozorenjima, priloženima uz uređaj, možete prema broju koji se nalazi uz pojedino upozorenje pronaći i njegov prijevod.

SAČUVAJTE OVE UPUTE**Upozornění DŮLEŽITÉ BEZPEČNOSTNÍ POKYNY**

Tento upozorňující symbol označuje nebezpečí. Jste v situaci, která by mohla způsobit nebezpečí úrazu. Před prací na jakémkoliv vybavení si uvědomte nebezpečí související s elektrickými obvody a seznamte se se standardními opatřeními pro předcházení úrazům. Podle čísla na konci každého upozornění vyhledejte jeho překlad v přeložených bezpečnostních upozorněních, která jsou přiložena k zařízení.

USCHOVEJTE TYTO POKYNY

Προειδοποίηση	<p>ΣΗΜΑΝΤΙΚΕΣ ΟΔΗΓΙΕΣ ΑΣΦΑΛΕΙΑΣ</p> <p>Αυτό το προειδοποιητικό σύμβολο σημαίνει κίνδυνο. Βρίσκεστε σε κατάσταση που μπορεί να προκαλέσει τραυματισμό. Πριν εργαστείτε σε οποιοδήποτε εξοπλισμό, να έχετε υπόψη σας τους κινδύνους που σχετίζονται με τα ηλεκτρικά κυκλώματα και να έχετε εξοικειωθεί με τις συνήθεις πρακτικές για την αποφυγή ατυχημάτων. Χρησιμοποιήστε τον αριθμό δήλωσης που παρέχεται στο τέλος κάθε προειδοποίησης, για να εντοπίσετε τη μετάφρασή της στις μεταφρασμένες προειδοποιήσεις ασφαλείας που συνοδεύουν τη συσκευή.</p> <p>ΦΥΛΑΞΤΕ ΑΥΤΕΣ ΤΙΣ ΟΔΗΓΙΕΣ</p>
אזהרה	<p style="text-align: right;">הוראות בטיחות חשובות</p> <p>סימן אזהרה זה מסמל סכנה. אתה נמצא במצב העלול לגרום לפציעה. לפני שתעבוד עם ציוד כלשהו, עליך להיות מודע לסכנות הכרוכות במגעלים חשמליים ולהכיר את הנהלים המקובלים למניעת תאונות. השתמש במספר ההוראה המסופק בסופה של כל אזהרה כדי לאתר את התרגום באזהרות הבטיחות המתורגמות שמצורפות להתקן.</p> <p style="text-align: right;">שמור הוראות אלה</p>
Opomena	<p>ВАЖНИ БЕЗБЕДНОСНИ НАПАТСТВИЈА</p> <p>Симболот за предупредување значи опасност. Се наоѓате во ситуација што може да предизвика телесни повреди. Пред да работите со опремата, бидете свесни за ризикот што постои кај електричните кола и треба да ги познавате стандардните постапки за спречување на несреќни случаи. Искористете го бројот на изјавата што се наоѓа на крајот на секое предупредување за да го најдете неговиот период во преведените безбедносни предупредувања што се испорачани со уредот.</p> <p>ЧУВАЈТЕ ГИ ОБИЕ НАПАТСТВИЈА</p>
Ostrzeżenie	<p>WAŻNE INSTRUKCJE DOTYCZĄCE BEZPIECZEŃSTWA</p> <p>Ten symbol ostrzeżenia oznacza niebezpieczeństwo. Zachodzi sytuacja, która może powodować obrażenia ciała. Przed przystąpieniem do prac przy urządzeniach należy zapoznać się z zagrożeniami związanymi z układami elektrycznymi oraz ze standardowymi środkami zapobiegania wypadkom. Na końcu każdego ostrzeżenia podano numer, na podstawie którego można odszukać tłumaczenie tego ostrzeżenia w dołączonym do urządzenia dokumencie z tłumaczeniami ostrzeżeń.</p> <p>NINIEJSZE INSTRUKCJE NALEŻY ZACHOWAĆ</p>
Upozornenie	<p>DÔLEŽITÉ BEZPEČNOSTNÉ POKYNY</p> <p>Tento varovný symbol označuje nebezpečenstvo. Nachádzate sa v situácii s nebezpečenstvom úrazu. Pred prácou na akomkoľvek vybavení si uvedomte nebezpečenstvo súvisiace s elektrickými obvodmi a oboznámte sa so štandardnými opatreniami na predchádzanie úrazom. Podľa čísla na konci každého upozornenia vyhľadajte jeho preklad v preložených bezpečnostných upozorneniach, ktoré sú priložené k zariadeniu.</p> <p>USCHOVAJTE SI TENTO NÁVOD</p>

Obtaining Optical Networking Information

This section contains information that is specific to optical networking products. For information that pertains to all of Cisco, refer to the [Obtaining Documentation and Submitting a Service Request](#) section.

Where to Find Safety and Warning Information

For safety and warning information, refer to the *Cisco Optical Transport Products Safety and Compliance Information* document that accompanied the product. This publication describes the international agency compliance and safety information for the Cisco ONS 15454 system. It also includes translations of the safety warnings that appear in the ONS 15454 system documentation.

Cisco Optical Networking Product Documentation CD-ROM

Optical networking-related documentation, including Cisco ONS 15xxx product documentation, is available in a CD-ROM package that ships with your product. The Optical Networking Product Documentation CD-ROM is updated periodically and may be more current than printed documentation.

Obtaining Documentation and Submitting a Service Request

For information on obtaining documentation, submitting a service request, and gathering additional information, see the monthly *What's New in Cisco Product Documentation*, which also lists all new and revised Cisco technical documentation, at:

<http://www.cisco.com/en/US/docs/general/whatsnew/whatsnew.html>

Subscribe to the *What's New in Cisco Product Documentation* as a Really Simple Syndication (RSS) feed and set content to be delivered directly to your desktop using a reader application. The RSS feeds are a free service and Cisco currently supports RSS version 2.0.



CHAPTER 1

General Troubleshooting

This chapter provides procedures for troubleshooting the most common problems encountered when operating a Cisco ONS 15454 DWDM shelf in ANSI or ETSI platforms. To troubleshoot specific alarms, see [Chapter 2, “Alarm Troubleshooting.”](#) If you cannot find what you are looking for, contact Cisco Technical Support (1-800-553-2447).



Note

In this chapter, “ONS 15454” refers to both ANSI and ETSI versions of the platform unless otherwise noted.

This chapter includes the following sections on network problems:



Note

For dense wavelength division multiplexing (DWDM) network acceptance tests, refer to the *Cisco ONS 15454 DWDM Procedure Guide*.

- [1.1 Loopback Description, page 1-2](#)—Explains in general terms the types of loopback tests (facility and terminal) that can be run along with general loopback behavior and card loopback behavior.
- [1.2 Troubleshooting MXP, TXP, XP, or ADM-10G Circuit Paths With Loopbacks, page 1-7](#)—Explains how to use loopbacks tests described in “[1.1 Loopback Description](#)” section on [page 1-2](#) to isolate trouble on muxponder (MXP) and transponder (TXP) circuits.
- [1.3 Troubleshooting DWDM Circuit Paths With ITU-T G.709 Monitoring, page 1-25](#)—Explains how to utilize performance monitoring (PM) and threshold crossing alerts (TCA) to locate signal degrades on DWDM circuit paths.

The remaining sections describe symptoms, problems, and solutions that are categorized according to the following topics:

- [1.4 Using CTC Diagnostics, page 1-33](#)—Explains how to perform card LED tests and download a diagnostic file for Cisco Technical Support.
- [1.5 Restoring the Database and Default Settings, page 1-37](#)—Provides procedures for restoring software data and restoring the node to the default setup.
- [1.6 PC Connectivity Troubleshooting, page 1-38](#)—Provides troubleshooting procedures for PC and network connectivity to the ONS 15454.
- [1.7 CTC Operation Troubleshooting, page 1-43](#)—Provides troubleshooting procedures for Cisco Transport Controller (CTC) login or operation problems.
- [1.8 Timing, page 1-53](#)—Provides troubleshooting procedures for circuit creation and error reporting as well as timing reference errors and alarms.

- [1.9 Fiber and Cabling, page 1-56](#)—Provides troubleshooting procedures for fiber and cabling connectivity errors.
- [1.10 Power Supply Problems, page 1-59](#)—Provides troubleshooting procedures for rack power supply problems.
- [1.11 Power Up Problems for Node and Cards, page 1-61](#)—Provides troubleshooting procedures for shelf and card power supply problems.
- [1.12 Network Level \(Internode\) Problems, page 1-61](#)—Provides troubleshooting procedures for problems between nodes, such as fiber cuts and optical channel network connection (OCHNC) circuit creation failure.
- [1.13 Node Level \(Intranode\) Problems, page 1-85](#)—Provides troubleshooting procedures for variable optical attenuator (VOA) startup problems as well as internal VOA control loop problems in the 32DMX-C and 32DMX-L cards that occur due to counter-propagating light.

1.1 Loopback Description

Use loopbacks and hairpin circuits to test newly created circuits before running live traffic or to logically locate the source of a network failure. All ONS 15454 and ONS 15454 SDH TXP and MXP cards allow loopbacks and hairpin test circuits. The ADM-10G allows loopbacks, but does not support hairpin circuits. Other cards do not allow loopbacks, OPT-AMP-C, OPT-AMP-17C to OPT-BST, OPT-PRE, OPT-BST, OPT-PRE, OSC-CSM, AD-xB-xx.x, and AD-xC-xx.x cards.

To create a loopback on an ANSI or SONET port, the port must be in the Out-of-Service and Management, Maintenance (OOS-MA,MT) service state. After you create the loopback, the service state becomes Out-of-Service and Management, Loopback and Maintenance (OOS-MA,LPBK & MT).

To create a loopback on an SDH or ETSI port, the port must be in the Locked, maintenance administrative state and the Locked-Enabled, loopback & maintenance administrative state.



Caution

Facility or terminal loopbacks can be service-affecting. To protect traffic, apply a lockout or Force switch to the target loopback port. Basic directions for these procedures exist in [Chapter 2, “Alarm Troubleshooting.”](#) For more information about these operations, refer to the “Maintain the Node” chapter in the *Cisco ONS 15454 DWDM Procedure Guide*.



Note

In CTC, a facility loopback is sometimes called “facility (line)” loopback, and a terminal loopback is sometimes called a “terminal (inward)” loopback. This is done to indicate the terminating direction of the signal: a facility loopback is sent outward toward the span, whereas a terminal loopback is redirected inward toward its originating port.

1.1.1 Facility Loopbacks

The following sections give general information about facility loopback operations and specific information about ONS 15454 or ONS 15454 SDH card loopback activity.

1.1.1.1 General Behavior

A facility loopback tests the line interface unit (LIU) of a card, the electrical interface assembly (EIA), and related cabling. After applying a facility loopback on a port, use a test set to run traffic over the loopback. A successful facility loopback isolates the LIU, the EIA, or the cabling plant as the potential cause of a network problem.

To test a card LIU, connect an optical test set to a trunk or client port and perform a facility loopback. Alternately, use a loopback or hairpin circuit on a card that is farther along the circuit path. For example, [Figure 1-1](#) shows a facility loopback at a trunk port and at a client port on a TXP card.

Figure 1-1 Facility Loopback Path on a Near-End Transponder Card

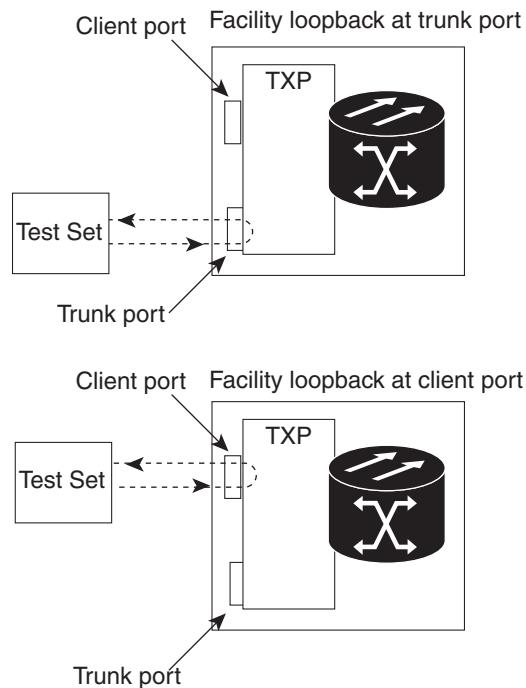

145758



Caution

Before performing a facility loopback on a TXP card, be sure that the card contains at least two data communications channel (DCC) paths to the node where the card is installed. A second DCC provides a nonlooped path to log into the node after the loopback is applied, enabling you to remove the facility loopback. Ensuring a second DCC is not necessary if you are directly connected to the node containing the loopback card.



Caution

Ensure that the facility being loopbacked is not being used by the node for line timing. If it is, a timing loop will be created.

1.1.1.2 Card Behavior

Port loopbacks either terminate or bridge the loopback signal. All MXP and TXP facility loopbacks are terminated as shown in [Table 1-1](#).

When a port terminates a facility loopback signal, the signal only loops back to the originating port and is not transmitted downstream. When a port bridges a loopback signal, the signal loops back to the originating port and is also transmitted downstream.

**Note**

In [Table 1-1](#), no alarm indication signal (AIS) is injected if the signal is bridged. If the signal is terminated, an applicable AIS is injected downstream.

Table 1-1 DWDM Card Facility Loopback Behavior

Card/Port	Facility Loopback Signal
TXP_MR_10E/TXP_MR_10E_C/TXP_MR_10E_L client ports	Bridged
TXP_MR_10E/TXP_MR_10E_C/TXP_MR_10E_L trunk ports	Terminated
TXP_MR_2.5G/TXPP_MR_2.5G client ports	Terminated
TXP_MR_2.5G/TXPP_MR_2.5G trunk ports	Terminated
MXP_2.5G_10E_C/MXP_2.5G_10E_L client ports	Bridged
MXP_2.5G_10E_C/MXP_2.5G_10E_L trunk ports	Terminated
MXP_MR_10DME client ports	Terminated
MXP_MR_10DME trunk ports	Terminated
MXP_MR_2.5G/MXPP_MR_2.5G client ports	Bridged
MXP_MR_2.5G/MXPP_MR_2.5G trunk ports	Terminated
GE_XP/10GE_XP client ports	Bridged
GE_XP/10GE_XP trunk ports	Terminated
ADM-10G client ports	Bridged
ADM-10G trunk ports	Terminated

The loopback itself is listed in the Conditions window. For example, the window would list the LPBKFACILITY condition for a tested port. (The Alarms window would show the AS-MT condition which means that alarms are suppressed on the facility during loopback unless the default is set to alarm for loopback while in AS-MT.)

With a client-side SONET or ANSI facility loopback, the client port service state is OOS-MA,LPBK & MT. However, any remaining client and trunk ports can be in any other service state. For SONET or ANSI cards in a trunk-side facility loopback, the trunk port service state is OOS-MA,LPBK & MT and the remaining client and trunk ports can be in any other service state.

With a client-side SDH or ESTI facility loopback, the client port is in the Locked-enabled,maintenance & loopback service state. However, the remaining client and trunk ports can be in any other service state. For MXP and TXP cards in a SDH or ETSI trunk-side facility loopback, the trunk port is in the Locked-enabled,maintenance & loopback service state and the remaining client and trunk ports can be in any other service state.

When you apply a facility loopback on the GE_XP, 10GE_XP, GE_XPE, and 10GE_XPE cards, the ifInDiscard counters increment continuously.

1.1.2 Terminal Loopbacks

The following sections give general information about terminal loopback operations and specific information about ONS 15454 card loopback activity.

1.1.2.1 General Behavior

A terminal loopback tests a circuit path as it passes through a TXP, MXP, or ADM-10G card and loops back. For example, as shown in Figure 1-2, there are two types of terminal loopbacks shown for a TXP card.

The first is a terminal loopback at the client port. In this situation, the test set traffic comes in through the TXP trunk port, travels through the card, and turns around because of the terminal loopback in effect on the card just before it reaches the LIU of the client port. The signal is then sent back through the card to the trunk port and back to the test set.

The second is a terminal loopback at the trunk port. In this situation, the test set traffic comes in through the TXP client port, travels through the card, and turns around because of the terminal loopback in effect on the card just before it reaches the LIU of the trunk port. The signal is then sent back through the card to the client port and back to the test set.

This test verifies that the terminal circuit paths are valid, but does not test the LIU on the TXP card.

Figure 1-2 Terminal Loopback on a TXP Card

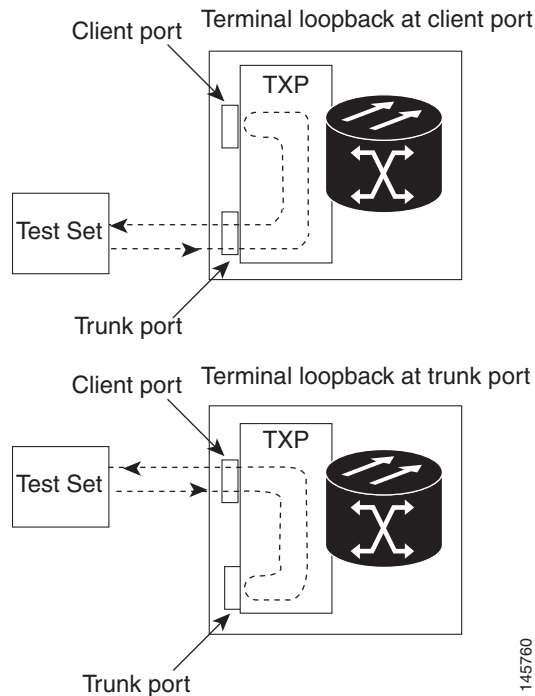

145760

1.1.2.2 Card Behavior

ONS 15454 and ONS 15454 SDH terminal port loopbacks can either terminate or bridge the signal. TXP terminal loopbacks are terminated as shown in [Table 1-2](#). During terminal loopbacks, if a port terminates a terminal loopback signal, the signal only loops back to the originating port and is not transmitted downstream. If the port bridges a loopback signal, the signal loops back to the originating port and is also transmitted downstream. Client card terminal loopback bridging and terminating behaviors are listed in [Table 1-2](#).

Note

In [Table 1-2](#), no AIS signal is injected if the signal is bridged. If the signal is terminated, an applicable AIS is injected downstream.

Table 1-2 DWDM Card Terminal Loopback Behavior

Card/Port	Terminal Loopback Signal
TXP_MR_10E/TXP_MR_10E_C/TXP_MR_10E_L client ports	Bridged
TXP_MR_10E/TXP_MR_10E_C/TXP_MR_10E_L trunk ports	Bridged
TXP_MR_2.5G/TXPP_MR_2.5G client ports	Bridged
TXP_MR_2.5G/TXPP_MR_2.5G trunk ports	Bridged
MXP_2.5G_10E_C/MXP_2.5G_10E_L client ports	Bridged
MXP_2.5G_10E_C/MXP_2.5G_10E_L trunk ports	Bridged
MXP_MR_10DME client ports	Bridged
MXP_MR_10DME trunk ports	Bridged
MXP_MR_2.5G/MXPP_MR_2.5G client ports	Bridged
MXP_MR_2.5G/MXPP_MR_2.5G trunk ports	Bridged
GE_XP/10GE_XP client ports	Bridged
GE_XP/10GE_XP trunk ports	Bridged
ADM-10G client ports	Bridged
ADM-10G trunk ports	Bridged

The MXP and TXP trunk and client ports can simultaneously maintain different service states:

- For SONET or ANSI TXP and TXPP cards with a client-side terminal loopback, the client port is in the OOS-MA,LPBK & MT service state and trunk port must be in IS-NR service state.
- For SONET or ANSI MXP and MXPP cards with a client-side terminal loopback, the client port is in the OOS-MA,LPBK & MT service state and the remaining client and trunk ports can be in any service state.
- For ADM-10G cards with Client Terminal Loopback on a SONET Client port, AIS-P is sent forward on client for the circuits on that port.
- For ADM-10G cards with a Terminal Loopback on a GE Client port, the client port is squelched.

- In SONET or ANSI MXP or TXP trunk-side terminal loopbacks, the trunk port is in the OOS-MA,LPBK & MT service state and the client ports must be in IS-NR service state for complete loopback functionality. A terminal loopback affects all client ports because it is performed on the aggregate signal.
- For ADM-10G cards with a Facility Loopback on the Trunk port, AIS-P is sent forward on all the SONET client ports.
- For ADM-10G cards with a Facility Loopback on the Trunk port, all the GE client ports is squelched
- For ADM-10G Terminal Loopback on the Trunk port, the signal is anyway sent downstream (drop and continue).
- For SDH or ETSI TXP and TXPP client-side facility loopbacks, the client port is in the Locked-enabled,maintenance & loopback service state and the trunk port must be in Unlocked-enabled service state.
- For SDH or ETSI MXP and MXPP cards with a client-side terminal loopback, the client port is in the Locked-enabled,maintenance & loopback service state and remaining client and trunk ports can be in any service state.
- In SDH and ETSI MXP or TXP trunk-side terminal loopbacks, the trunk port is in the Locked-enabled,maintenance & loopback service state and the client ports must be in Unlocked-enabled service state for complete loopback functionality. A facility loopback affects all client ports because it is performed on the aggregate signal.

The loopback itself is listed in the Conditions window. For example, the window would list the LPBKTERMINAL condition or LPBKFACILITY condition for a tested port. (The Alarms window would show the AS-MT condition, which indicates that all alarms are suppressed on the port during loopback testing unless the default is set to alarm for loopback while in AS-MT.)

1.2 Troubleshooting MXP, TXP, XP, or ADM-10G Circuit Paths With Loopbacks

Facility loopbacks and terminal loopbacks are often used together to test the circuit path through the network or to logically isolate a fault. Performing a loopback test at each point along the circuit path systematically isolates possible points of failure. MXP, TXP, XP, or ADM-10G card loopback tests differ from other testing in that loopback testing does not require circuit creation. MXP, TXP, and XP client ports are statically mapped to the trunk ports so no signal needs to traverse the cross-connect card (in a circuit) to test the loopback.

You can use these procedures on transponder cards (TXP, TXPP, ADM-10G), muxponder, or xponder cards (MXP, MXPP, XP, ADM-10G) cards. The example in this section tests an MXP or TXP circuit on a three-node bidirectional line switched ring (BLSR) or multiplex section-shared protection ring (MS-SPRing). Using a series of facility loopbacks and terminal loopbacks, the example scenario traces the circuit path, tests the possible failure points, and eliminates them. The logical progression contains six network test procedures:



Note

MXP, TXP, XP, or ADM-10G card client ports do not appear when you click the Maintenance > Loopback tab unless they have been provisioned. Do this in the card view by clicking the Provisioning > Pluggable Port Modules tab. For information about provisioning client ports, refer to the *Cisco ONS 15454 DWDM Procedure Guide*.

**Note**

The test sequence for your circuits will differ according to the type of circuit and network topology.

1. A facility loopback on the source-node MXP, TXP, XP, or ADM-10G port
2. A terminal loopback on the source-node MXP, TXP, XP, or ADM-10G port
3. A facility loopback on the intermediate-node MXP, TXP, XP, or ADM-10G port
4. A terminal loopback on the intermediate-node MXP, TXP, XP, or ADM-10G port
5. A facility loopback on the destination-node MXP, TXP, XP, or ADM-10G port
6. A terminal loopback on the destination-node MXP, TXP, XP, or ADM-10G port

**Note**

Facility and terminal loopback tests require on-site personnel.

1.2.1 Perform a Facility Loopback on a Source-Node MXP or TXP Port

This facility loopback test is performed on the node source port in the network circuit. In the testing situation used in this example, the source muxponder, transponder, xponder, or ADM-10G port under test is located in the source node. Facility loopback can be performed at the trunk port or at a client port. Completing a successful facility loopback on this port isolates the source MXP, TXP, XP, or ADM-10G port as a possible failure point. [Figure 1-3](#) shows the facility loopback examples on source ONS node TXP ports (client and trunk).

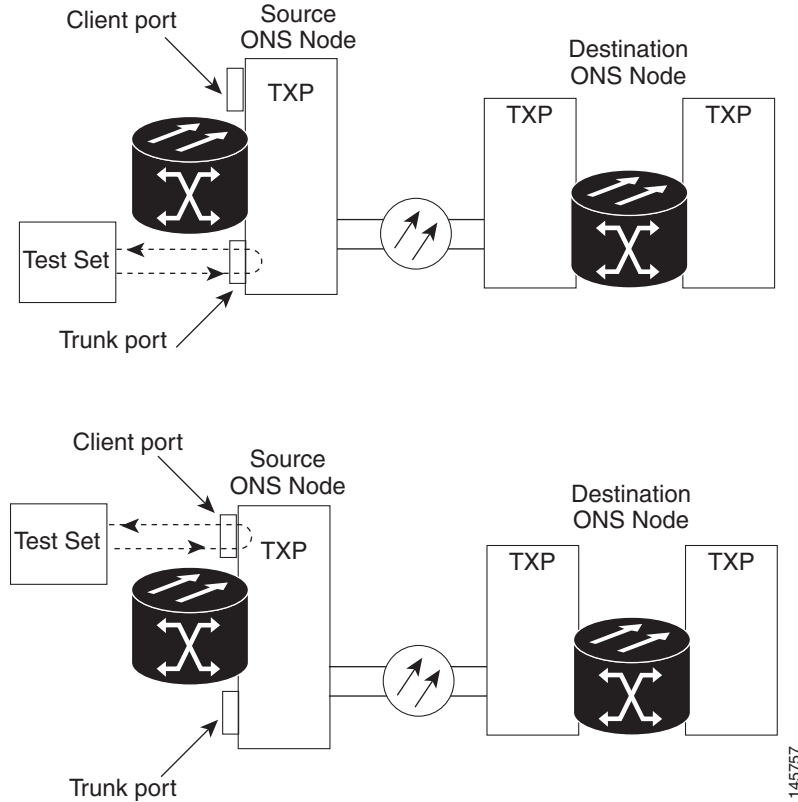
Figure 1-3 Facility Loopback on a Circuit Source MXP or TXP Port**Caution**

Performing a loopback on an in-service circuit is service-affecting.

**Note**

Facility loopbacks require on-site personnel.

Complete the “[Create the Facility Loopback on the Source-Node MXP, TXP, XP or ADM-10G Port](#)” procedure on page 1-9.

Create the Facility Loopback on the Source-Node MXP, TXP, XP or ADM-10G Port

- Step 1** Connect an optical test set to the port you are testing.

**Note**

For specific procedures to connect, set up, and use the test set equipment, consult the manufacturer.

Use appropriate cabling to attach the transmit (Tx) and receive (Rx) terminals of the optical test set to the port you are testing. The Tx and Rx terminals connect to the same port.

- Step 2** Adjust the test set accordingly. (Refer to manufacturer instructions for test set use.)

- Step 3** In node view (single-shelf mode) or shelf view (multishelf mode), double-click the card to display the card view.
- Step 4** Click the **Maintenance > Loopback** tabs.
- Step 5** Choose **OOS,MT** (or **locked,maintenance**) from the Admin State column for the port being tested. If this is a multiport card, select the appropriate row for the desired port.
- Step 6** Choose **Facility (Line)** from the Loopback Type column for the port being tested. If this is a multiport card, select the appropriate row for the desired port.
- Step 7** Click **Apply**.
- Step 8** Click **Yes** in the confirmation dialog box.



Note It is normal for the “[LPBKFACILITY \(ESCON\)](#)” condition on page 2-149, “[LPBKFACILITY \(FC\)](#)” condition on page 2-150, “[LPBKFACILITY \(GE\)](#)” condition on page 2-150, “[LPBKFACILITY \(ISC\)](#)” condition on page 2-151 or the “[LPBKFACILITY \(TRUNK\)](#)” condition on page 2-152 to appear during loopback setup. The condition clears when you remove the loopback.

- Step 9** Complete the “[Test and Clear the MXP, TXP, XP or ADM-10G Facility Loopback Circuit](#)” procedure on page 1-10.

Test and Clear the MXP, TXP, XP or ADM-10G Facility Loopback Circuit

- Step 1** If the test set is not already sending traffic, send test traffic on the loopback circuit.
- Step 2** Examine the traffic received by the test set. Look for errors or any other signal information that the test set is capable of indicating.
- Step 3** If the test set indicates no errors, no further testing is necessary with the facility loopback. Clear the facility loopback:
- Click the **Maintenance > Loopback** tabs.
 - Choose **None** from the Loopback Type column for the port being tested.
 - Choose the appropriate state to place the port in service, out of service and disabled, out of service for maintenance, or automatically in service from the Admin State column for the port being tested.
 - Click **Apply**.
 - Click **Yes** in the confirmation dialog box.
 - Complete the “[1.2.2 Perform a Terminal Loopback on a Source-Node MXP, TXP, XP, or ADM-10G Port](#)” procedure on page 1-11.
- Step 4** If the test set indicates errors, complete the “[Test the MXP, TXP, XP or ADM-10G Card](#)” procedure on page 1-11.

Test the MXP, TXP, XP or ADM-10G Card

Step 1 Complete the “[Physically Replace a Card](#)” procedure on page 2-244 for the suspected bad card and replace it with a known-good one.

**Warning**

High-performance devices on this card can get hot during operation. To remove the card, hold it by the faceplate and bottom edge. Allow the card to cool before touching any other part of it or before placing it in an antistatic bag. Statement 201

**Caution**

Removing a card that currently carries traffic on one or more ports can cause a traffic hit. To avoid this, perform an external switch if a switch has not already occurred. Refer to the procedures in the “[2.8.2 Protection Switching, Lock Initiation, and Clearing](#)” section on page 2-237. For more information, refer to the “Maintain the Node” chapter in the *Cisco ONS 15454 DWDM Procedure Guide*.

Step 2 Resend test traffic on the loopback circuit with a known-good card installed.

Step 3 If the test set indicates no errors, the problem was probably the defective card. Return the defective card to Cisco through the Return Materials Authorization (RMA) process. Contact Cisco Technical Support (1-800-553-2447).

Step 4 Clear the facility loopback:

- a. Click the **Maintenance > Loopback** tabs.
- b. Choose **None** from the Loopback Type column for the port being tested.
- c. Choose the appropriate state to place the port in service, out of service and disabled, out of service for maintenance, or automatically in service from the Admin State column for the port being tested.
- d. Click **Apply**.
- e. Click **Yes** in the confirmation dialog box.

Step 5 Complete the “[1.2.2 Perform a Terminal Loopback on a Source-Node MXP, TXP, XP, or ADM-10G Port](#)” procedure on page 1-11.

1.2.2 Perform a Terminal Loopback on a Source-Node MXP, TXP, XP, or ADM-10G Port

The terminal loopback test is performed on the node source MXP, TXP, XP, or ADM-10G port. For the circuit in this example, it is the source TXP trunk port or a client port in the source node. Completing a successful terminal loopback to a node source port verifies that the circuit is through the source port. [Figure 1-4](#) shows an example of a terminal loopback on a source TXP port and a client TXP port.

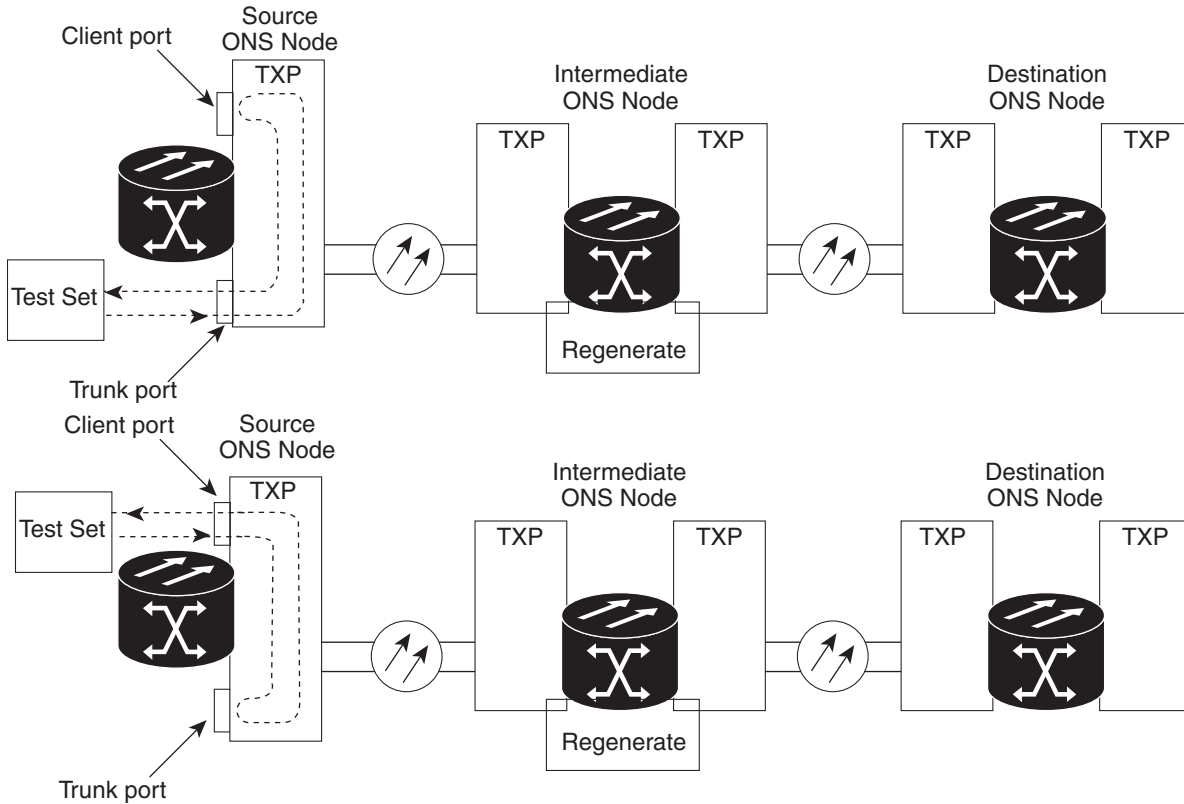
Figure 1-4 Terminal Loopback on a Source-Node MXP or TXP Port

 **Caution**

Performing a loopback on an in-service circuit is service-affecting.

 **Note**

Terminal loopbacks require on-site personnel.

Complete the [“Create the Terminal Loopback on a Source-Node MXP, TXP, XP, or ADM-10G Port” procedure on page 1-12.](#)

Create the Terminal Loopback on a Source-Node MXP, TXP, XP, or ADM-10G Port

Step 1 Connect an optical test set to the port you are testing:



Note For specific procedures to connect, set up, and use the test set equipment, consult the manufacturer.

- a. If you just completed the [“1.2.1 Perform a Facility Loopback on a Source-Node MXP or TXP Port” procedure on page 1-8,](#) leave the optical test set hooked up to the MXP, TXP, XP, or ADM-10G port in the source node.

- b. If you are starting the current procedure without the optical test set hooked up to the source port, use appropriate cabling to attach the Tx and Rx terminals of the optical test set to the port you are testing. Both Tx and Rx connect to the same port.
- Step 2** Adjust the test set accordingly. (Refer to manufacturer instructions for test set use.)
- Step 3** In node view (single-shelf mode) or shelf view (multishelf mode), double-click the card that requires the loopback.
- Step 4** Click the **Maintenance > Loopback** tabs.
- Step 5** Select **OOS,MT** (or **locked,maintenance**) from the Admin State column. If this is a multiport card, select the row appropriate for the desired port.
- Step 6** Select **Terminal (Inward)** from the Loopback Type column. If this is a multiport card, select the row appropriate for the desired port.
- Step 7** Click **Apply**.
- Step 8** Click **Yes** in the confirmation dialog box.
- Step 9** Complete the [“Test and Clear the MXP, TXP, XP, or ADM-10G Port Terminal Loopback Circuit” procedure on page 1-13](#).
-

Test and Clear the MXP, TXP, XP, or ADM-10G Port Terminal Loopback Circuit

- Step 1** If the test set is not already sending traffic, send test traffic on the loopback circuit.
- Step 2** Examine the test traffic being received by the test set. Look for errors or any other signal information that the test set is capable of indicating.
- Step 3** If the test set indicates no errors, no further testing is necessary on the loopback circuit. Clear the terminal loopback state on the port:
- a. Double-click the card in the source node with the terminal loopback.
 - b. Click the **Maintenance > Loopback** tabs.
 - c. Select **None** from the Loopback Type column for the port being tested.
 - d. Choose the appropriate state to place the port in service, out of service and disabled, out of service for maintenance, or automatically in service from the Admin State column for the port being tested.
 - e. Click **Apply**.
 - f. Click **Yes** in the confirmation dialog box.
 - g. Complete the [“1.2.3 Create a Facility Loopback on an Intermediate-Node MXP or TXP Port” procedure on page 1-14](#).
- Step 4** If the test set indicates errors, complete the [“Test the MXP, TXP, XP, or ADM-10G Card” procedure on page 1-13](#).
-

Test the MXP, TXP, XP, or ADM-10G Card

- Step 1** Complete the [“Physically Replace a Card” procedure on page 2-244](#) for the suspected bad card and replace it with a known-good one.

**Warning**

High-performance devices on this card can get hot during operation. To remove the card, hold it by the faceplate and bottom edge. Allow the card to cool before touching any other part of it or before placing it in an antistatic bag. Statement 201

**Caution**

Removing a card that currently carries traffic on one or more ports can cause a traffic hit. To avoid this, perform an external switch if a switch has not already occurred. Refer to the procedures in the [“2.8.2 Protection Switching, Lock Initiation, and Clearing” section on page 2-237](#). For more information, refer to the “Maintain the Node” chapter in the *Cisco ONS 15454 DWDM Procedure Guide*.

- Step 2** Resend test traffic on the loopback circuit with a known-good card.
- Step 3** If the test set indicates no errors, the problem was probably the defective card. Return the defective card to Cisco through the RMA process. Contact Cisco Technical Support (1-800-553-2447).
- Step 4** Clear the terminal loopback on the port before testing the next segment of the network circuit path:
- Double-click the card in the source node with the terminal loopback.
 - Click the **Maintenance > Loopback** tabs.
 - Select **None** from the Loopback Type column for the port being tested.
 - Choose the appropriate state to place the port in service, out of service and disabled, out of service for maintenance, or automatically in service from the Admin State column for the port being tested.
 - Click **Apply**.
 - Click **Yes** in the confirmation dialog box.
- Step 5** Complete the [“1.2.3 Create a Facility Loopback on an Intermediate-Node MXP or TXP Port” procedure on page 1-14](#).

1.2.3 Create a Facility Loopback on an Intermediate-Node MXP or TXP Port

Performing the facility loopback test on an intermediate port isolates whether this node is causing circuit failure. In the situation shown in [Figure 1-5](#), the test is being performed on an intermediate MXP or TXP port.

Figure 1-5 Facility Loopback on an Intermediate-Node MXP or TXP Port

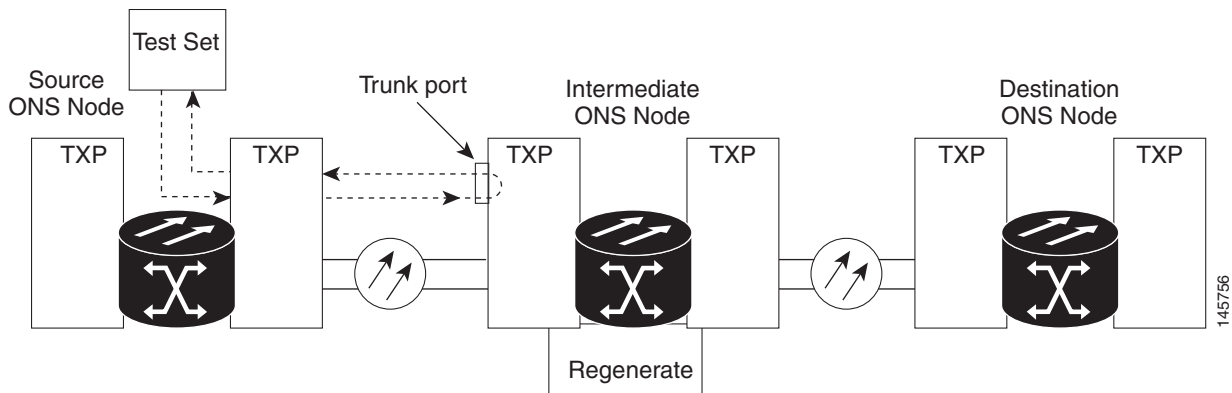

Caution

Performing a loopback on an in-service circuit is service-affecting.

Note

Facility loopbacks require on-site personnel.

Complete the [“Create a Facility Loopback on an Intermediate-Node MXP or TXP Port” procedure on page 1-15](#).

Create a Facility Loopback on an Intermediate-Node MXP or TXP Port

Step 1 Connect an optical test set to the port you are testing:



Note For specific procedures to connect, set up, and use the test set equipment, consult the manufacturer.

- a. If you just completed the [“1.2.2 Perform a Terminal Loopback on a Source-Node MXP, TXP, XP, or ADM-10G Port” procedure on page 1-11](#), leave the optical test set hooked up to the source-node port.
- b. If you are starting the current procedure without the optical test set hooked up to the source port, use appropriate cabling to attach the Tx and Rx terminals of the optical test set to the port you are testing. Both Tx and Rx connect to the same port.

Step 2 Adjust the test set accordingly. (Refer to manufacturer instructions for test set use.)

Step 3 In node view (single-shelf mode) or shelf view (multishelf mode), double-click the intermediate-node card that requires the loopback.

Step 4 Click the **Maintenance > Loopback** tabs.

Step 5 Select **OOS,MT** (or **locked,maintenance**) from the Admin State column. If this is a multiport card, select the row appropriate for the desired port.

Step 6 Select **Facility (Line)** from the Loopback Type column. If this is a multiport card, select the row appropriate for the desired port.

Step 7 Click **Apply**.

- Step 8** Click **Yes** in the confirmation dialog box.
- Step 9** Complete the [“Test and Clear the MXP or TXP Port Facility Loopback Circuit” procedure on page 1-16](#).
-

Test and Clear the MXP or TXP Port Facility Loopback Circuit

- Step 1** If the test set is not already sending traffic, send test traffic on the loopback circuit.
- Step 2** Examine the traffic received by the test set. Look for errors or any other signal information that the test set is capable of indicating.
- Step 3** If the test set indicates no errors, no further testing is necessary with the facility loopback. Clear the facility loopback from the port:
- Click the **Maintenance > Loopback** tabs.
 - Choose **None** from the Loopback Type column for the port being tested.
 - Choose the appropriate state to place the port in service, out of service and disabled, out of service for maintenance, or automatically in service from the Admin State column for the port being tested.
 - Click **Apply**.
 - Click **Yes** in the confirmation dialog box.
 - Complete the [“1.2.4 Create a Terminal Loopback on Intermediate-Node MXP or TXP Ports” procedure on page 1-17](#).
- Step 4** If the test set indicates errors, complete the [“Test the MXP or TXP Card” procedure on page 1-16](#).
-

Test the MXP or TXP Card

- Step 1** Complete the [“Physically Replace a Card” procedure on page 2-244](#) for the suspected bad card and replace it with a known-good one.



Warning

High-performance devices on this card can get hot during operation. To remove the card, hold it by the faceplate and bottom edge. Allow the card to cool before touching any other part of it or before placing it in an antistatic bag. Statement 201



Caution

Removing a card that currently carries traffic on one or more ports can cause a traffic hit. To avoid this, perform an external switch if a switch has not already occurred. Refer to the procedures in the [“2.8.2 Protection Switching, Lock Initiation, and Clearing” section on page 2-237](#). For more information, refer to the “Maintain the Node” chapter in the *Cisco ONS 15454 DWDM Procedure Guide*.

- Step 2** Resend test traffic on the loopback circuit with a known-good card installed.
- Step 3** If the test set indicates no errors, the problem was probably the defective card. Return the defective card to Cisco through the RMA process. Contact Cisco Technical Support (1-800-553-2447).
- Step 4** Clear the facility loopback from the port:
- Click the **Maintenance > Loopback** tabs.

- b. Choose **None** from the Loopback Type column for the port being tested.
- c. Choose the appropriate state to place the port in service, out of service and disabled, out of service for maintenance, or automatically in service from the Admin State column for the port being tested.
- d. Click **Apply**.
- e. Click **Yes** in the confirmation dialog box.

Step 5 Complete the “[1.2.4 Create a Terminal Loopback on Intermediate-Node MXP or TXP Ports](#)” procedure on page 1-17.

1.2.4 Create a Terminal Loopback on Intermediate-Node MXP or TXP Ports

In the next troubleshooting test, you perform a terminal loopback on the intermediate-node port to isolate whether the intermediate client or trunk port is causing circuit trouble. In the example situation in [Figure 1-6](#), the terminal loopback is performed on an intermediate MXP or TXP port in the circuit. If you successfully complete a terminal loopback on the node, this node is excluded from possible sources of circuit trouble.

Figure 1-6 Terminal Loopback on an Intermediate-Node MXP or TXP Port

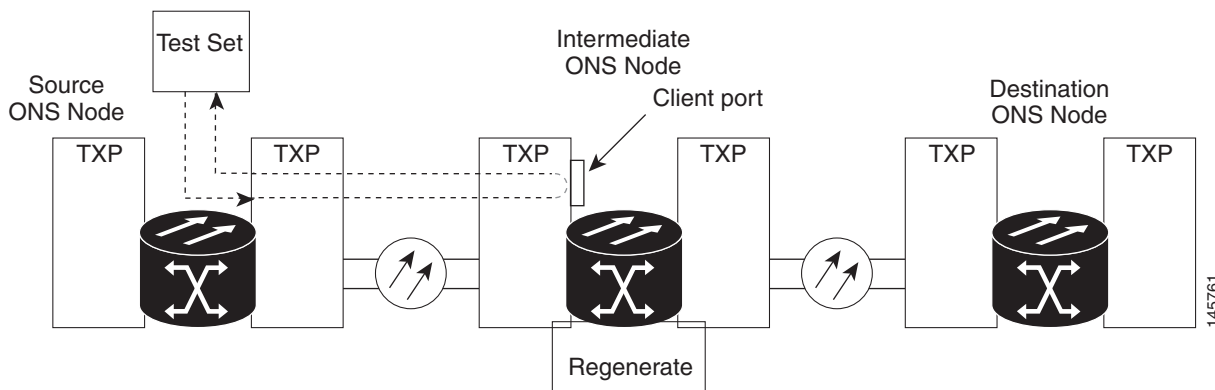

Caution

Performing a loopback on an in-service circuit is service-affecting.



Note

Terminal loopbacks require on-site personnel.

Complete the “[Create a Terminal Loopback on Intermediate-Node MXP or TXP Ports](#)” procedure on page 1-17.

Create a Terminal Loopback on Intermediate-Node MXP or TXP Ports

Step 1 Connect an optical test set to the port you are testing:



Note For specific procedures to connect, set up, and use the test set equipment, consult the manufacturer.

- a. If you just completed the “[1.2.3 Create a Facility Loopback on an Intermediate-Node MXP or TXP Port](#)” section on page 1-14, leave the optical test set hooked up to the source-node port.
- b. If you are starting the current procedure without the optical test set hooked up to the source port, use appropriate cabling to attach the Tx and Rx terminals of the optical test set to the port you are testing. Both Tx and Rx connect to the same port.

Step 2 Adjust the test set accordingly. (Refer to manufacturer instructions for test set use.)

Step 3 Create the terminal loopback on the destination port being tested:

- a. Go to node view (single-shelf mode) or shelf view (multishelf mode) of the intermediate node:
 - Choose **View > Go To Other Node** from the menu bar.
 - Choose the node (or shelf) from the drop-down list in the Select Node dialog box and click **OK**.
- b. In node view (single-shelf mode) or shelf view (multishelf mode), double-click the card that requires the loopback.
- c. Click the **Maintenance > Loopback** tabs.
- d. Select **OOS,MT** (or **locked,maintenance**) from the Admin State column. If this is a multiport card, select the row appropriate for the desired port.
- e. Select **Terminal (Inward)** from the Loopback Type column. If this is a multiport card, select the row appropriate for the desired port.
- f. Click **Apply**.
- g. Click **Yes** in the confirmation dialog box.

Step 4 Complete the “[Test and Clear the MXP or TXP Terminal Loopback Circuit](#)” procedure on page 1-18.

Test and Clear the MXP or TXP Terminal Loopback Circuit

Step 1 If the test set is not already sending traffic, send test traffic on the loopback circuit.

Step 2 Examine the test traffic being received by the test set. Look for errors or any other signal information that the test set is capable of indicating.

Step 3 If the test set indicates no errors, no further testing is necessary on the loopback circuit. Clear the terminal loopback from the port:

- a. Double-click the intermediate-node card with the terminal loopback to display the card view.
- b. Click the **Maintenance > Loopback** tabs.
- c. Select **None** from the Loopback Type column for the port being tested.
- d. Choose the appropriate state to place the port in service, out of service and disabled, out of service for maintenance, or automatically in service from the Admin State column for the port being tested.
- e. Click **Apply**.
- f. Click **Yes** in the confirmation dialog box.

- g. Complete the “[1.2.5 Perform a Facility Loopback on a Destination-Node MXP, TXP, XP, or ADM-10G Port](#)” procedure on page 1-19.
- Step 4** If the test set indicates errors, complete the “[Test the MXP or TXP Card](#)” procedure on page 1-19.
-

Test the MXP or TXP Card

- Step 1** Complete the “[Physically Replace a Card](#)” procedure on page 2-244 for the suspected bad card and replace it with a known-good one.



Warning

High-performance devices on this card can get hot during operation. To remove the card, hold it by the faceplate and bottom edge. Allow the card to cool before touching any other part of it or before placing it in an antistatic bag. Statement 201



Caution

Removing a card that currently carries traffic on one or more ports can cause a traffic hit. To avoid this, perform an external switch if a switch has not already occurred. Refer to the procedures in the “[2.8.2 Protection Switching, Lock Initiation, and Clearing](#)” section on page 2-237. For more information, refer to the “Maintain the Node” chapter in the *Cisco ONS 15454 DWDM Procedure Guide*.

- Step 2** Resend test traffic on the loopback circuit with a known-good card.
- Step 3** If the test set indicates no errors, the problem was probably the defective card. Return the defective card to Cisco through the RMA process. Contact Cisco Technical Support (1-800-553-2447).
- Step 4** Clear the terminal loopback on the port:
- a. Double-click the source-node card with the terminal loopback.
 - b. Click the **Maintenance > Loopback** tabs.
 - c. Select **None** from the Loopback Type column for the port being tested.
 - d. Choose the appropriate state to place the port in service, out of service and disabled, out of service for maintenance, or automatically in service from the Admin State column for the port being tested.
 - e. Click **Apply**.
 - f. Click **Yes** in the confirmation dialog box.
- Step 5** Complete the “[1.2.5 Perform a Facility Loopback on a Destination-Node MXP, TXP, XP, or ADM-10G Port](#)” procedure on page 1-19.
-

1.2.5 Perform a Facility Loopback on a Destination-Node MXP, TXP, XP, or ADM-10G Port

You perform a facility loopback test at the destination port to determine whether this local port is the source of circuit trouble. The example in [Figure 1-7](#) shows a facility loopback being performed on a TXP client or trunk port at a destination node.

Figure 1-7 Facility Loopback on a Destination-Node MXP or TXP Port

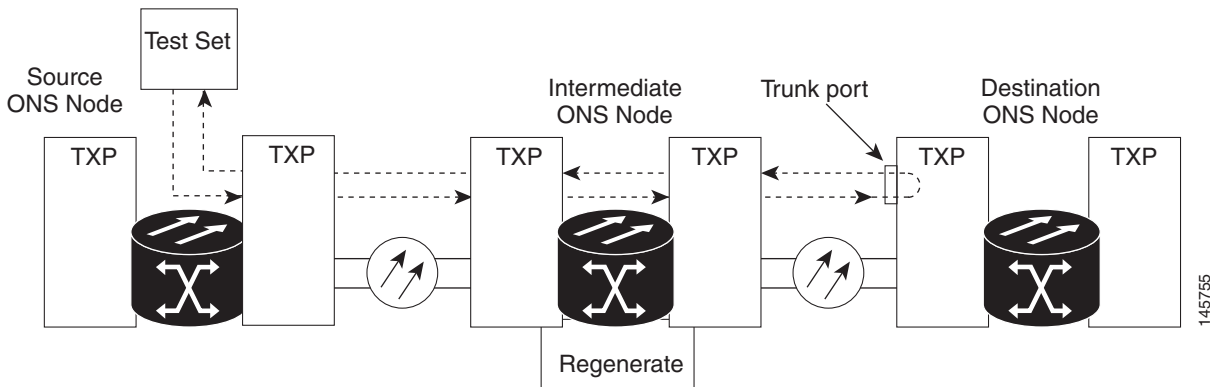

Caution

Performing a loopback on an in-service circuit is service-affecting.



Note

Facility loopbacks require on-site personnel.

Complete the [“Create the Facility Loopback on a Destination-Node MXP, TXP, XP, or ADM-10G Port” procedure on page 1-20.](#)

Create the Facility Loopback on a Destination-Node MXP, TXP, XP, or ADM-10G Port

Step 1 Connect an optical test set to the port you are testing:



Note

For specific procedures to connect, set up, and use the test set equipment, consult the manufacturer.

- a. If you just completed the [“1.2.4 Create a Terminal Loopback on Intermediate-Node MXP or TXP Ports” procedure on page 1-17](#), leave the optical test set hooked up to the source-node port.
- b. If you are starting the current procedure without the optical test set hooked up to the source port, use appropriate cabling to attach the Tx and Rx terminals of the optical test set to the port you are testing. Both Tx and Rx connect to the same port.

Step 2 Adjust the test set accordingly. (Refer to manufacturer instructions for test set use.)

Step 3 Create the facility loopback on the destination port being tested:

- a. Go to the node view (single-shelf mode) or shelf view (multishelf mode) of the destination node:
 - Choose **View > Go To Other Node** from the menu bar.
 - Choose the node (or shelf) from the drop-down list in the Select Node dialog box and click **OK**.
- b. In node view (single-shelf mode) or shelf view (multishelf mode), double-click the card that requires the loopback.
- c. Click the **Maintenance > Loopback** tabs.
- d. Select **OOS,MT** (or **locked,maintenance**) from the Admin State column. If this is a multiport card, select the row appropriate for the desired port.

- e. Select **Facility (Line)** from the Loopback Type column. If this is a multiport card, select the row appropriate for the desired port.
 - f. Click **Apply**.
 - g. Click **Yes** in the confirmation dialog box.
- Step 4** Complete the “[Test and Clear the MXP, TXP, XP, or ADM-10G Facility Loopback Circuit](#)” procedure on page 1-21.
-

Test and Clear the MXP, TXP, XP, or ADM-10G Facility Loopback Circuit

- Step 1** If the test set is not already sending traffic, send test traffic on the loopback circuit.
- Step 2** Examine the traffic received by the test set. Look for errors or any other signal information that the test set is capable of indicating.
- Step 3** If the test set indicates no errors, no further testing is necessary with the facility loopback. Clear the facility loopback from the port:
- a. Click the **Maintenance > Loopback** tabs.
 - b. Choose **None** from the Loopback Type column for the port being tested.
 - c. Choose the appropriate state to place the port in service, out of service and disabled, out of service for maintenance, or automatically in service from the Admin State column for the port being tested.
 - d. Click **Apply**.
 - e. Click **Yes** in the confirmation dialog box.
 - f. Complete the “[1.2.6 Perform a Terminal Loopback on a Destination-Node MXP, TXP, XP, or ADM-10G Port](#)” procedure on page 1-22.
- Step 4** If the test set indicates errors, complete the “[Test the MXP, TXP, XP, or ADM-10G Card](#)” procedure on page 1-21.
-

Test the MXP, TXP, XP, or ADM-10G Card

- Step 1** Complete the “[Physically Replace a Card](#)” procedure on page 2-244 for the suspected bad card and replace it with a known-good one.

**Warning**

High-performance devices on this card can get hot during operation. To remove the card, hold it by the faceplate and bottom edge. Allow the card to cool before touching any other part of it or before placing it in an antistatic bag. Statement 201

**Caution**

Removing a card that currently carries traffic on one or more ports can cause a traffic hit. To avoid this, perform an external switch if a switch has not already occurred. Refer to the procedures in the “[2.8.2 Protection Switching, Lock Initiation, and Clearing](#)” section on page 2-237. For more information, refer to the “Maintain the Node” chapter in the *Cisco ONS 15454 DWDM Procedure Guide*.

- Step 2** Resend test traffic on the loopback circuit with a known-good card installed.
- Step 3** If the test set indicates no errors, the problem was probably the defective card. Return the defective card to Cisco through the RMA process. Contact Cisco Technical Support (1-800-553-2447).
- Step 4** Clear the facility loopback on the port:
- Click the **Maintenance > Loopback** tabs.
 - Choose **None** from the Loopback Type column for the port being tested.
 - Choose the appropriate state to place the port in service, out of service and disabled, out of service for maintenance, or automatically in service from the Admin State column for the port being tested.
 - Click **Apply**.
 - Click **Yes** in the confirmation dialog box.
- Step 5** Complete the “[1.2.6 Perform a Terminal Loopback on a Destination-Node MXP, TXP, XP, or ADM-10G Port](#)” procedure on page 1-22.

1.2.6 Perform a Terminal Loopback on a Destination-Node MXP, TXP, XP, or ADM-10G Port

The terminal loopback at the destination-node port is the final local hardware error elimination in the circuit troubleshooting process. If this test is completed successfully, you have verified that the circuit is good up to the destination port. The example in [Figure 1-8](#) shows a terminal loopback on an destination node TXP port.

Figure 1-8 Terminal Loopback on a Destination-Node MXP or TXP Port

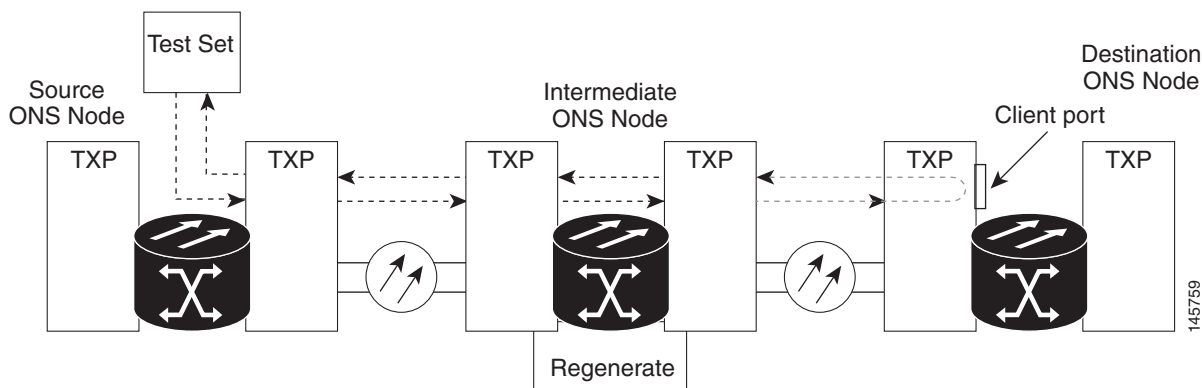

Caution

Performing a loopback on an in-service circuit is service-affecting.



Note

Terminal loopbacks require on-site personnel.

Complete the “[Create the Terminal Loopback on a Destination-Node MXP, TXP, XP, or ADM-10G Port](#)” procedure on page 1-23.

Create the Terminal Loopback on a Destination-Node MXP, TXP, XP, or ADM-10G Port

Step 1 Connect an optical test set to the port you are testing:



Note For specific procedures to connect, set up, and use the test set equipment, consult the manufacturer.

- a. If you just completed the [“1.2.5 Perform a Facility Loopback on a Destination-Node MXP, TXP, XP, or ADM-10G Port” procedure on page 1-19](#), leave the optical test set hooked up to the source port.
- b. If you are starting the current procedure without the optical test set hooked up to the source port, use appropriate cabling to attach the Tx and Rx terminals of the optical test set to the port you are testing. Both Tx and Rx connect to the same port.

Step 2 Adjust the test set accordingly. (Refer to manufacturer instructions for test set use.)



Note It is normal for the [“LPBKTERMINAL \(ESCON\)” condition on page 2-152](#), [“LPBKTERMINAL \(FC\)” condition on page 2-152](#), [“LPBKTERMINAL \(GE\)” condition on page 2-153](#), [“LPBKTERMINAL \(ISC\)” condition on page 2-154](#) or the [“LPBKTERMINAL \(TRUNK\)” condition on page 2-154](#) to appear during loopback setup. The condition clears when you remove the loopback.

Step 3 Create the terminal loopback on the destination port being tested:

- a. Go to the node view (single-shelf mode) or shelf view (multishelf mode) of the destination node:
 - Choose **View > Go To Other Node** from the menu bar.
 - Choose the node (or shelf) from the drop-down list in the Select Node dialog box and click **OK**.
- b. In node view (single-shelf mode) or shelf view (multishelf mode), double-click the card that requires the loopback.
- c. Click the **Maintenance > Loopback** tabs.
- d. Select **OOS,MT (or locked,maintenance)** from the Admin State column. If this is a multiport card, select the row appropriate for the desired port.
- e. Select **Terminal (Inward)** from the Loopback Type column. If this is a multiport card, select the row appropriate for the desired port.
- f. Click **Apply**.
- g. Click **Yes** in the confirmation dialog box.

Step 4 Complete the [“Test and Clear the MXP, TXP, XP, or ADM-10G Terminal Loopback Circuit” procedure on page 1-23](#).

Test and Clear the MXP, TXP, XP, or ADM-10G Terminal Loopback Circuit

Step 1 If the test set is not already sending traffic, send test traffic on the loopback circuit.

Step 2 Examine the test traffic being received by the test set. Look for errors or any other signal information that the test set is capable of indicating.

- Step 3** If the test set indicates no errors, no further testing is necessary on the loopback circuit. Clear the terminal loopback from the port:
- Double-click the intermediate-node card with the terminal loopback.
 - Click the **Maintenance > Loopback** tabs.
 - Select **None** from the Loopback Type column for the port being tested.
 - Choose the appropriate state to place the port in service, out of service and disabled, out of service for maintenance, or automatically in service from the Admin State column for the port being tested.
 - Click **Apply**.
 - Click **Yes** in the confirmation dialog box.
- Step 4** If the test set indicates errors, the problem might be a faulty card.
- Step 5** Complete the [“Test the MXP, TXP, XP, or ADM-10G Card” procedure on page 1-24](#).
-

Test the MXP, TXP, XP, or ADM-10G Card

- Step 1** Complete the [“Physically Replace a Card” procedure on page 2-244](#) for the suspected bad card and replace it with a known-good one.



Warning

High-performance devices on this card can get hot during operation. To remove the card, hold it by the faceplate and bottom edge. Allow the card to cool before touching any other part of it or before placing it in an antistatic bag. Statement 201



Caution

Removing a card that currently carries traffic on one or more ports can cause a traffic hit. To avoid this, perform an external switch if a switch has not already occurred. Refer to the procedures in the [“2.8.2 Protection Switching, Lock Initiation, and Clearing” section on page 2-237](#). For more information, refer to the “Maintain the Node” chapter in the *Cisco ONS 15454 DWDM Procedure Guide*.

- Step 2** Resend test traffic on the loopback circuit with a known-good card.
- Step 3** If the test set indicates no errors the problem was probably the defective card. Return the defective card to Cisco through the RMA process. Contact Cisco Technical Support (1-800-553-2447).
- Step 4** Clear the terminal loopback on the port:
- Double-click the source-node card with the terminal loopback.
 - Click the **Maintenance > Loopback** tabs.
 - Select **None** from the Loopback Type column for the port being tested.
 - Choose the appropriate state to place the port in service, out of service and disabled, out of service for maintenance, or automatically in service from the Admin State column for the port being tested.
 - Click **Apply**.
 - Click **Yes** in the confirmation dialog box.

The entire circuit path has now passed its comprehensive series of loopback tests. This circuit qualifies to carry live traffic.

1.3 Troubleshooting DWDM Circuit Paths With ITU-T G.709 Monitoring

This section provides an overview of the optical transport network (OTN) specified in ITU-T G.709, *Network Node Interface for the Optical Transport Network*, and provides troubleshooting procedures for DWDM circuit paths in the ITU-T G.709 OTN using PM and TCAs.

1.3.1 ITU-T G.709 Monitoring in Optical Transport Networks

ITU-T Recommendation G.709 is part of a suite of recommendations covering the full functionality of an OTN. ITU-T G.709 enables single-wavelength SONET transparent optical wavelength-based networks. ITU-T G.709 adds the Operation, Administration, Maintenance, and Provisioning (OAM&P) functionality of SONET/SDH to DWDM optical networks. It adds extra overhead to existing SONET, Ethernet, or asynchronous transfer mode (ATM) bit streams for performance management and improvement.

Like traditional SONET networks, ITU-T G.709 optical networks have a layered design (Figure 1-9). This structure enables localized monitoring that helps you isolate and troubleshoot network problems.

Figure 1-9 Optical Transport Network Layers

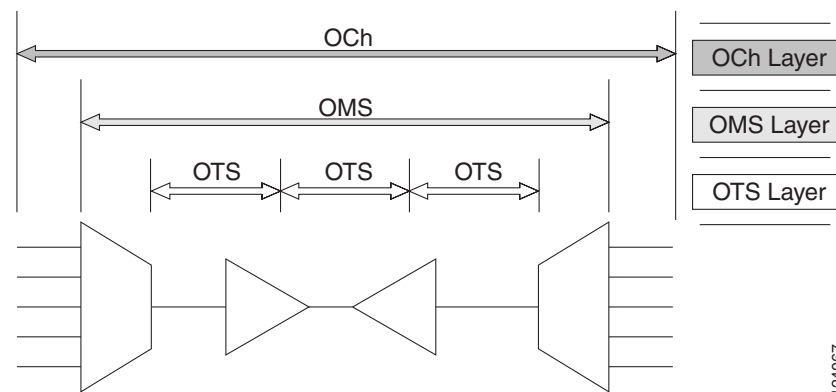

124067

1.3.2 Optical Channel Layer

The optical channel (OCH) layer is the outermost part of the OTN and spans from client to client. The optical channel is built as follows:

1. A client signal such as SONET, Gigabit Ethernet, IP, ATM, Fibre Channel, or enterprise system connection (ESCON) is mapped to a client payload area and combined with an overhead to create the optical channel payload unit (OPUk).
2. A second overhead is added to the OPUk unit to create the optical channel data unit (ODUk).
3. A third overhead including forward error correction (FEC) is added to the ODUk to create the optical channel transport unit (OTUk).
4. A fourth overhead is added to the OTUk to create the entire OCH layer.

1.3.3 Optical Multiplex Section Layer

The optical multiplex section (OMS) of the OTN allows carriers to identify errors occurring within DWDM network sections. The OMS layer consists of a payload and an overhead (OMS-OH). It supports the ability to monitor multiplexed sections of the network, for example, the span between an optical multiplexer such as the 32MUX-O card and an optical demultiplexer such as the 32DMX-O card.

1.3.4 Optical Transmission Section Layer

The optical transmission section (OTS) layer supports monitoring partial spans of a network's multiplexed sections. This layer consists of a payload and an overhead (OTS-OH). It is a transmission span between two elements in an optical network, such as between:

- A multiplexer such as the 32MUX-O card and an amplifier such as the OPT-PRE card
- An amplifier and another amplifier, such as the OPT-BST card and the OPT-PRE card
- An amplifier such as the OPT-BST card and a demultiplexer such as the 32DMX card

1.3.5 Performance Monitoring Counters and Threshold Crossing Alerts

PM counters and TCAs can be used for identifying trouble and troubleshooting problems in ITU-T G.709 optical transport networks. ITU-T Recommendation M.2401 recommends that the following PM parameters be monitored at the ODUk layer:

- SES (severely errored seconds)—A one-second period that contains greater than or equal to 30 percent errored blocks or at least one defect. SES is a subset of the errored second (ES) parameter, which is a one-second period with one or more errored blocks or at least one defect.
- BBE (background block error counter)—An errored block not occurring as part of an SES. BBE is a subset of the errored block (EB) parameter, which is a block in which one or more bits are in error.

Different PM count parameters are associated with different read points in a network. [Figure 1-10](#) illustrates the PM read points that are useful in identifying DWDM circuit points of failure. The “Performance Monitoring” chapter in the *Cisco ONS 15454 DWDM Reference Manual* lists all PM parameters and provides block diagrams of signal entry points, exit points, and interconnections between the individual circuit cards. Consult these specifications to determine which PM parameters are associated with the system points you want to monitor or provision with CTC or TL1. The monitoring points might vary according to your configuration.



Note

When LOS, LOS-P, or LOF alarms occur on TXP and MXP trunks, G709/SONET/SDH TCAs are suppressed. For details, see the “Alarm and TCA Monitoring and Management” chapter in the *Cisco ONS 15454 DWDM Reference Manual*.

Figure 1-10 Performance Monitoring Points on ONS DWDM

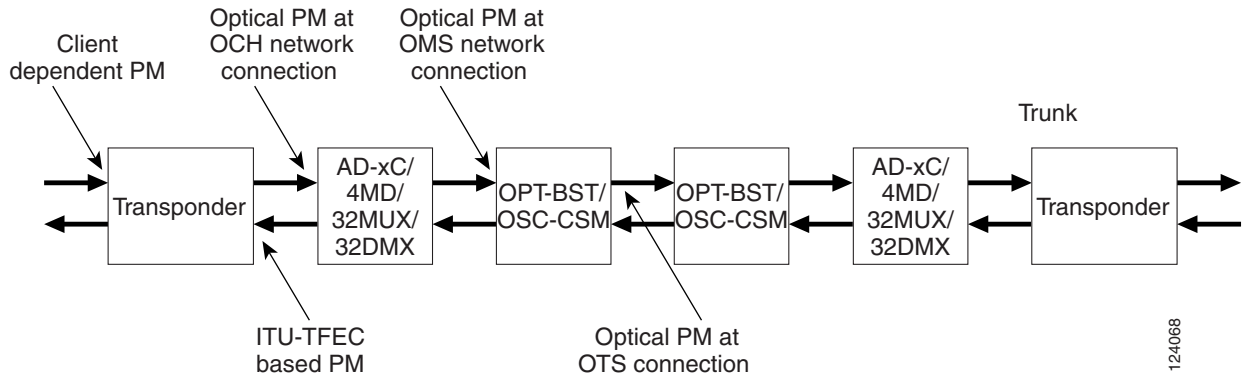

TCAs are used to monitor performance through the management interface by indicating whether preset thresholds have been crossed, or whether a transmission (such as a laser transmission) is degraded. TCAs are not associated with severity levels. They are usually associated with rate, counter, and percentage parameters that are available at transponder monitoring points. The “Performance Monitoring” chapter in the *Cisco ONS 15454 DWDM Reference Manual* contains more information about these alerts.

Select and complete the following procedures according to your network parameters.

Set Node Default BBE or SES Card Thresholds

Complete the following procedure to provision default node ODUk BBE and SES PM thresholds for TXP cards.

- Step 1** In node view (single-shelf mode) or multishelf view (multishelf mode), click the **Provisioning > Defaults** tabs (Figure 1-11).

Figure 1-11 Set Default BBE/SES Card Thresholds

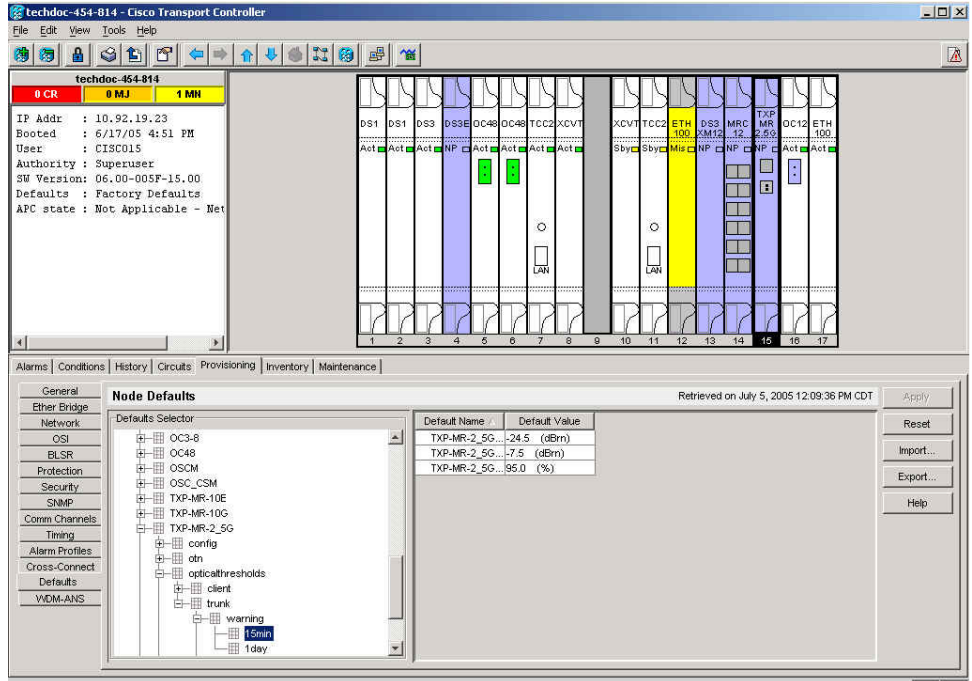

- Step 2** In the Defaults Selector field, click the card you wish to provision, then click **opticalthresholds > trunk > warning > 15min** in the drop-down list.

Provision Individual Card BBE or SES Thresholds in CTC

Complete the following procedure to provision BBE or SES PM thresholds in CTC for an individual TXP card.

- Step 1** In node view (single-shelf mode) or shelf view (multishelf mode), double-click the applicable card (TXP, MXP, or XP.)
- Step 2** Click the **Provisioning > OTN > G.709 Thresholds** tabs (Figure 1-12).

Figure 1-12 Provision Card BBE/SES Thresholds

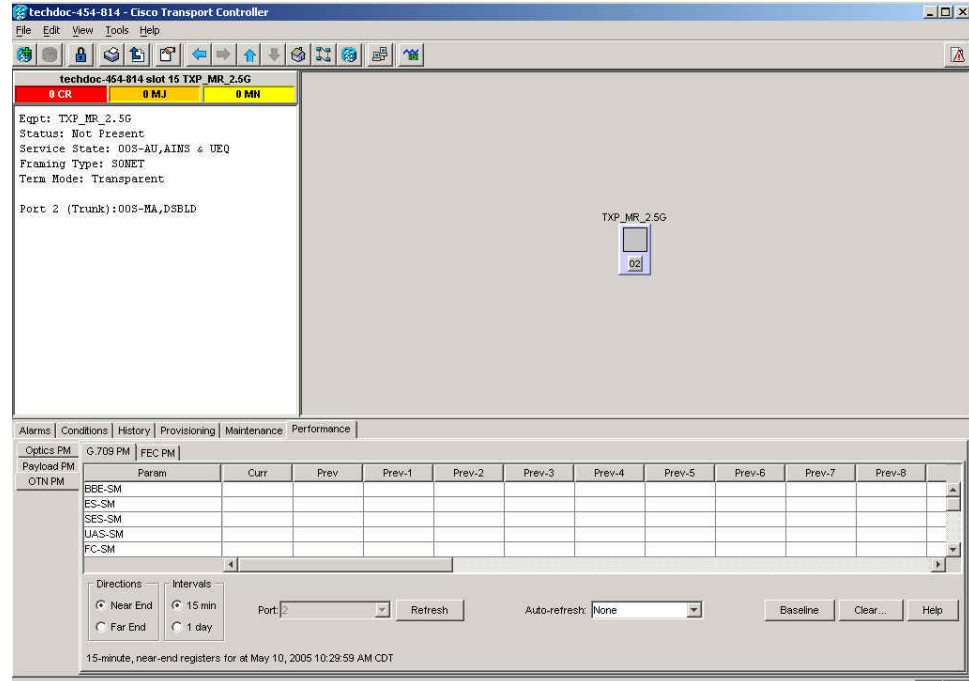

- Step 3** In the Directions area, click the **Near End** radio button.
- Step 4** In the Intervals area, click the **15 Min** radio button.
- Step 5** In the Types area, click the **PM (ODUk)** radio button.
- Step 6** In the SES and BBE fields, enter threshold numbers, for example 500 and 10000.

Provision Card PM Thresholds Using TL1

Complete the following procedure if you wish to provision PM thresholds in TL1 rather than in CTC.

- Step 1** Open a TL1 command line (click **Tools > Open TL1 Connection**).
- Step 2** In the TL1 command line, enter a command using the following syntax:
 SET-TH-OCH:[<TID>]:<AID>:<CTAG>::<MONTYPE>,<THLEV>,[<LOCN>],[<TMPER>];
 where:

- Access Identifier (AID) identifies the NE to which the command pertains. All the OCH, STS, VT1, facility, and DS1 AIDs are supported.
- The parameter MONTYPE is the monitored type.
- The parameter THLEV is optional and indicates a threshold count value (the number of errors that must be exceeded before the threshold is crossed).
- The parameter LOCN specifies the location associated with the particular command.
- The parameter TMPER is optional and is an accumulation time period for performance counters, with possible values of 1-DAY, 1-HR, 1-MIN, 15-MIN, and RAW-DATA.

**Note**

For a more information about this command and a list of TL1 commands, refer to the *Cisco SONET TL1 Command Guide* at the following link:

http://www.cisco.com/en/US/products/hw/optical/ps2006/products_command_reference_book_09186a0080483b9b.html

Provision Optical TCA Thresholds

Complete the following procedure to provision TCA thresholds in CTC.

- Step 1** In card view, click the **Provisioning > Optics Thresholds** tabs (Figure 1-13).

Figure 1-13 Provision Optical TCA Thresholds

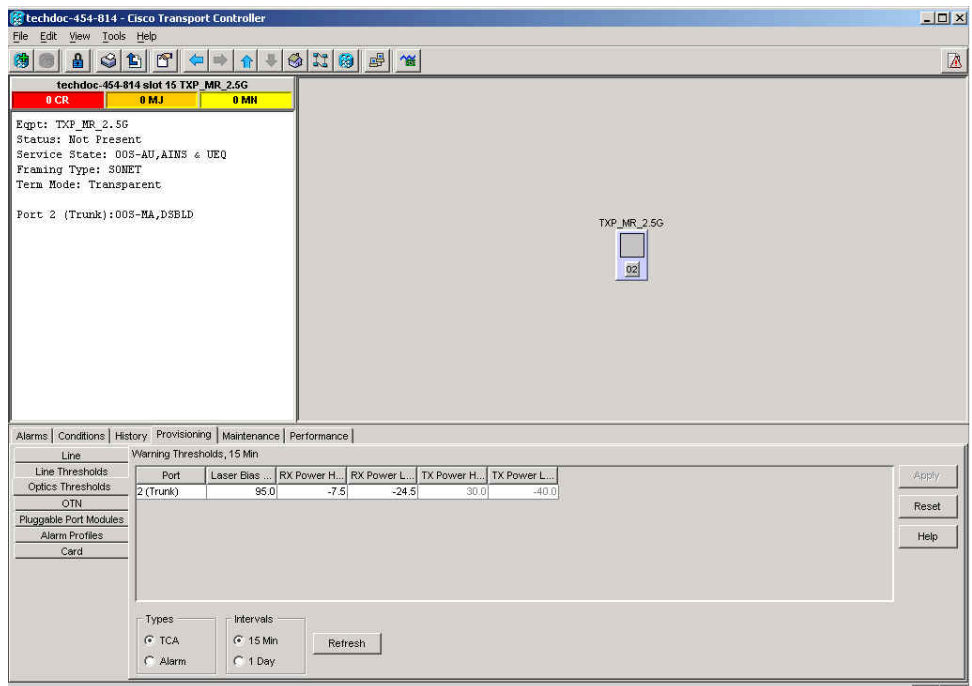

- Step 2** In the Types area, click **TCA**.
- Step 3** In the Intervals area, click **15 Min**.
- Step 4** In the Laser Bias High (%) field, enter the threshold value, for example, 81.0 percent.

1.3.6 Forward Error Correction

In DWDM spans, FEC reduces the quantities of retiming, reshaping, and regeneration (3R) needed to maintain signal quality. The following two PM parameters are associated with FEC:

- BIT-EC—Bit errors corrected (BIT-EC) indicates the number of bit errors corrected in the DWDM trunk line during the PM time interval.
- UNC-WORDS—The number of uncorrectable words detected in the DWDM trunk line during the PM time interval.

Complete the following procedure to provision BIT-EC and UNC-WORDS PM parameters for FEC.

Provision Card FEC Thresholds

- Step 1** In node view (single-shelf mode) or shelf view (multishelf mode), double-click a transponder, muxponder, or xponder card to open the card view.
- Step 2** Click the **Provisioning > OTN > FEC Thresholds** tabs (Figure 1-14).

Figure 1-14 Provision Card FEC Thresholds

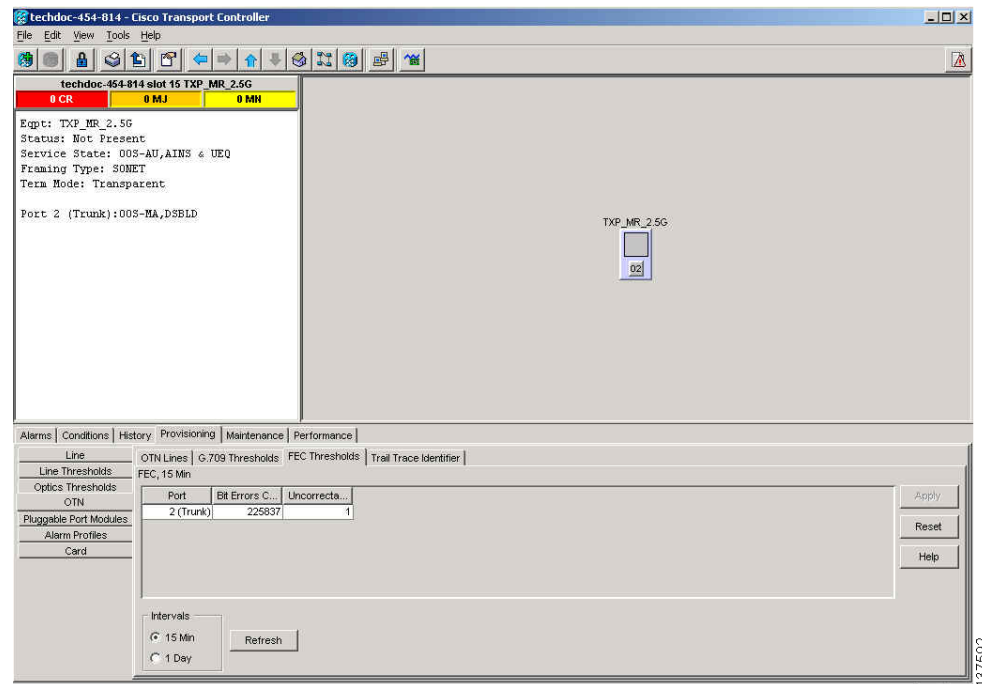

- Step 3** In the Bit Errors Corrected field, enter a threshold number, for example 225837.
- Step 4** In the Uncorrectable Words field, enter a threshold number, for example, 2.
- Step 5** In the Intervals area, click **15 Min**.

1.3.7 Sample Trouble Resolutions

The following sample trouble resolutions use PM and TCAs to isolate degrade points.

Symptom There is a BBE TCA on a single transponder pair.

Possible Cause The transponder input power is out of range.

Recommended Action Check the input power on the transponder. It should be within the specified/supported range.

Possible Cause There are dirty trunk connectors on the transponder.

Recommended Action Check the connector on the trunk port.

Possible Cause There is a degraded trunk patchcord between the transponder and the DWDM port.

Recommended Action Check the patchcord on the transponder DWDM port.

Possible Cause There are dirty client connectors on the ADxC-xx.x card transmit port or the demultiplexer (DMX) has crossed the near-end TCA.

Recommended Action Check the connector on the OCH port of the ADxC-xx.x card.

Possible Cause There are dirty client connectors on the ADxC-xx.x card receive port or the multiplexer (MUX) has crossed the far-end TCA point.

Recommended Action If an optical channel bypass exists along the line, check the connectors.

Symptom There is a BBE TCA on all transponders connected to an ADxB-xx.x card.

Possible Cause The transponder input power is out of range.

Recommended Action Check the input power on the transponder. It should be within the specified/supported range.

Possible Cause There is a dirty connector on the 4MD-xx.x card port.

Recommended Action Check the connector on the drop port of the 4MD-xx.x card.

Possible Cause There is a dirty connector on the ADxB-xx.x card drop port, and it has crossed the near-end TCA point.

Recommended Action Check the connector on the drop port of the ADxB-xx.x card.

Possible Cause There is a dirty connector on the ADxB-xx.x card add port and it has crossed the far-end TCA.

Recommended Action Check the patchcord on the 4MD-xx.x or AD1B-xx.x card.

Possible Cause There is a degraded patchcord between the ADxB-xx.x and 4MD-xx.x cards.

Recommended Action If an optical band bypass exists along the line, check the band connectors.

Symptom There is a BBE TCA on all transponders that the OCH passes through a single OTS section.

Possible Cause This is not a transponder or channel-related issue.

Recommended Action The problem is in the intercabinet signal path preceding the transponder. Refer to the *Cisco ONS 15454 DWDM Procedure Guide* for more information about configurations and acceptance tests for this area.

Symptom You have a laser bias current (LBC) TCA on a single transponder.

Possible Cause The laser of the transponder is degrading.

Recommended Action The problem is within the laser circuitry. Check the OPT-PRE, OPT-BST, OPT-AMP-C, and OPT-AMP-17C optical amplifier cards. Refer to the *Cisco ONS 15454 DWDM Procedure Guide* for more information about setting up these cards.

1.4 Using CTC Diagnostics

In Software Release 9.0, CTC provides diagnostics for the following functions:

- Verifying proper card application-specific integrated circuit (ASIC) functionality
- Verifying standby card operation
- Verifying proper card LED operation
- Diagnostic circuit creation
- Customer problem notifications detected by alarms
- Provision of a downloadable, machine-readable diagnostic information file to be used by Cisco Technical Support

Some of these functions, such as ASIC verification and standby card operation, are invisibly monitored in background functions. Change or problem notifications are provided in the Alarms and Conditions windows. Other diagnostic functions—verifying card LED function, creating bidirectional diagnostic circuits, and also downloading diagnostic files for technical support—are available to the user in the node view (single-shelf mode) or shelf view (multishelf mode) Maintenance > Diagnostic tab. The user-operated diagnostic features are described in the following paragraphs.

1.4.1 Card LED Lamp Tests

A card LED lamp test determines whether card-level indication LEDs are operational. This diagnostic test is run as part of the initial ONS 15454 turn-up, during maintenance routines, or any time you question whether an LED is in working order. Maintenance or higher-level users can complete the following tasks to verify LED operation.

Verify Card LED Operation

-
- Step 1** In node view (single-shelf mode) or shelf view (multishelf mode), click the **Maintenance > Diagnostic** tabs ([Figure 1-15](#)).

Figure 1-15 ONS 15454 Node View Diagnostic Window

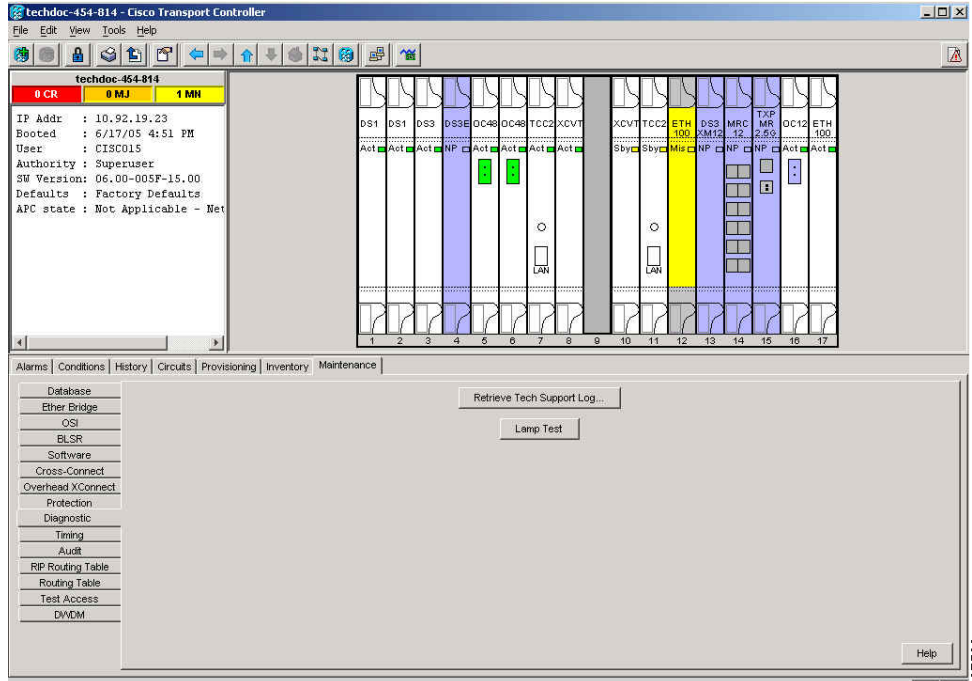

Step 2 Click **Lamp Test**.

Step 3 Watch to make sure all the port LEDs illuminate simultaneously for several seconds, with the following durations:

- For tri-color LEDs: three 5-second cycles
- For dual-color LEDs: one 5-second cycle and one 10-second cycle
- For the AIC or AIC-I: one 15-second cycle

Step 4 Click **OK** in the Lamp Test Run dialog box.

1.4.2 Retrieve Tech Support Logs Button

When you click the Retrieve Tech Support Logs button in the Diagnostics tab of the Maintenance window, CTC retrieves system data that a Retrieve or higher level user can off-load to a local directory and sent to Technical Support for troubleshooting purposes. The diagnostics file is in machine language and is not human-readable, but can be used by Cisco Technical Support for problem analysis. Complete the following procedure to off-load the diagnostics file.



Note

In addition to the machine-readable diagnostics file, the ONS 15454 stores an audit trail of all system events such as user log-ins, remote log-ins, configuration, and changes. This audit trail is considered a record-keeping feature rather than a troubleshooting feature. Information about the feature is located in the “Maintain the Node” chapter of the *Cisco ONS 15454 Procedure Guide*.

Off-Load the Diagnostics File



Note

The diagnostics operation is performed at a shelf level. Only single-node-related diagnostic information can be downloaded at a time.

The diagnostic files retrieved by CTC depends on the user privilege levels. [Table 1-3](#) lists the user privilege levels and the diagnostic retrieval operations they can perform.

Table 1-3 Diagnostic Files Retrieved Based on User Privilege

User Privilege Level	Diagnostic File Retrieval Operation
Retrieve	<ul style="list-style-type: none"> Export the unfiltered alarm table contents Export the unfiltered conditions table contents Export the unfiltered history table contents Export the inventory table contents CTC Dump Diagnostics log
Maintenance	<ul style="list-style-type: none"> All Retrieve level access operations Save the node database
Provisioning	<ul style="list-style-type: none"> All Maintenance level access operations Retrieve and save the node-level diagnostics report¹ Export the audit table contents²
Superuser	<ul style="list-style-type: none"> All Provisioning level access operations Retrieve and save the node-level diagnostics report Export the audit table contents

1. If secure mode is not set on the node.

2. If the `NODE.security.grantPermission.RetrieveAuditLog` NE Default is set to "Provisioning."

Step 1 In the node view, click the **Maintenance > Diagnostic** tabs ([Figure 1-15](#)).

Step 2 Click **Retrieve Tech Support Logs** in the Controller area.

Step 3 In the Select a Filename for the Tech Support Logs Zip Archive dialog box, add the diagnostics file name in the format **TechSupportLogs_<node_name>.zip** by default. Substitute the last 20 alphanumeric characters of the node name for `<node_name>`. Navigate to the directory (local or network) where you want to save the file.

A message appears asking you if you want to overwrite any existing diagnostics file in the selected directory.

Step 4 Click **Save**.

CTC performs the diagnostic tasks and writes the diagnostic files in a folder named `TechSupportLogs_<node_name>` under the location selected in [Step 3](#). After all the diagnostic files are written to the `TechSupportLogs_<node_name>` folder, CTC archives the retrieved diagnostic files as `TechSupportLogs_<node_name>.zip`. CTC deletes the `TechSupportLogs_<node_name>` folder after the archiving process is successfully completed. CTC retains this folder if the archiving process fails. The retrieved diagnostic files can be accessed in the `TechSupportLogs_<node_name>` folder.

A progress bar indicates the percentage of the file that is being saved. The Save Tech Support Logs Completed dialog box appears when the file is saved. CTC logs any error during the retrieval and archiving of diagnostics file to the CTC Alerts Log.

Table 1-4 lists the diagnostic files retrieved by CTC.

Table 1-4 List of Diagnostic Files

Diagnostic File	Diagnostic File Content
AlarmTableLog.html	Alarm Table export
HistoryTableLog.html	Alarm Table export
ConditionsTableLog.html	Conditions Table export
InventoryTableLog.html	Inventory Table export
AuditTableLog.html	Audit Table export
CTCDumpDiagLog.txt	Audit Table export
NodeDiagnostics.bin	NodeDiagnostics.gz
OBFLDiagnostics.bin	OBFLDiagnostics.bin
NodeDatabaseBackup.bin	Database backup
TechSupportLogs_<node_name>.zip	Zip archive of all the diagnostics file

Step 5 Click **OK**.

1.4.3 Data Communications Network Tool

CTC contains a data communications network (DCN) tool that assists with network troubleshooting for Open Shortest Path First (OSPF) networks. This tool, located in network view, is shown in Figure 1-16. It executes an internal dump command to retrieve information about all nodes accessible from the entry point.

Figure 1-16 DCN Tools OSPF Dump

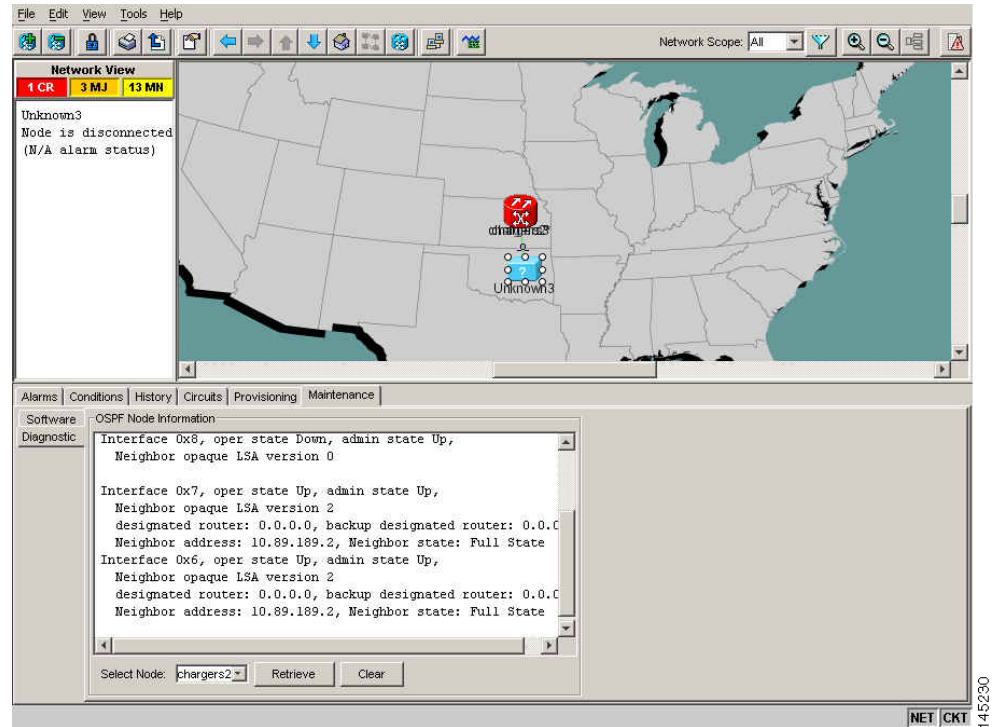

The dump, which provides the same information as a dump executed by special networking commands, is available at the network view in the Maintenance > Diagnostic tab. You can select the access point node in the Select Node drop-down list. To create the dump, click Retrieve. (To clear the dump, click Clear.)

The contents of the dump file can be saved or printed and furnished to Cisco Technical Support for use in OSPF network support.

1.5 Restoring the Database and Default Settings

This section contains troubleshooting for node operation errors that require restoration of software data or the default node setup.

1.5.1 Restore the Node Database

Symptom One or more nodes do not function properly or have incorrect data.

Possible Cause Incorrect or corrupted node database.

Recommended Action Complete the procedures in the “Maintain the Node” chapter of the *Cisco ONS 15454 DWDM Procedure Guide*.

1.6 PC Connectivity Troubleshooting

This section contains information about system minimum requirements, supported platforms, browsers, and Java Runtime Environments (JREs) for Software R9.0, and troubleshooting procedures for PC and network connectivity to the ONS 15454.

1.6.1 PC System Minimum Requirements

Workstations running CTC Software R9.0 for the Optical Networking System (ONS) products on Windows platforms need to have the following minimum requirements:

- Pentium III or higher processor
- Processor speed of at least 700 MHz
- 256 MB or more of RAM
- 50 MB or more of available hard disk space
- 20 GB or larger hard drive

1.6.2 Sun System Minimum Requirements

Workstations running Software R9.0 for the ONS products on Sun workstations need to have the following minimum requirements:

- UltraSPARC or faster processor
- 256 MB or more of RAM
- 50 MB or more of available hard disk space

1.6.3 Supported Platforms, Browsers, and JREs

Software R9.0 supports the following platforms:

- Windows NT
- Windows 98
- Windows XP
- Windows 2000
- Solaris 8
- Solaris 9
- Solaris 10

Software R9.0 supports the following browsers and JREs:

- Netscape 7 browser (PC or Solaris 8 or 9 with Java plug-in 1.4.2 or 5.0, or Solaris 10 with JRE 5.0)
- PC platforms with Java plug-in 5.0
- Internet Explorer 6.0 browser (on PC platforms with Java plug-in 5.0)
- Mozilla 1.7 (Solaris only)

**Note**

You can obtain browsers at the following URLs:

- Netscape: <http://channels.netscape.com/ns/browsers/default.jsp>
- Internet Explorer: <http://www.microsoft.com>
- Mozilla: <http://mozilla.org>

**Note**

JRE 5.0 is required to run Software R9.0. JRE 5.0 is provided on the software CD.

1.6.4 Unsupported Platforms and Browsers

Software R9.0 does not support the following platforms:

- Windows 95
- Solaris 2.5
- Solaris 2.6

Software R9.0 does not support the following browsers and JREs:

- Netscape 4.73 for Windows.
- Netscape 4.76 on Solaris.
- Netscape 7 on Solaris 8 or 9 is only supported with JRE 1.4.2 and above.

1.6.5 Unable to Verify the IP Configuration of Your PC

Symptom When connecting your PC to the ONS 15454, you are unable to successfully ping the IP address of your PC to verify the IP configuration.

Possible Cause The IP address was entered incorrectly.

Recommended Action Verify that the IP address used to ping the PC matches the IP address displayed when in the Windows IP Configuration information retrieved from the system. See the [“Verify the IP Configuration of Your PC” procedure on page 1-39](#).

Possible Cause The IP configuration of your PC is not properly set.

Recommended Action Verify the IP configuration of your PC. Complete the [“Verify the IP Configuration of Your PC” procedure on page 1-39](#). If this procedure is unsuccessful, contact your network administrator for instructions to correct the IP configuration of your PC.

Verify the IP Configuration of Your PC

-
- Step 1** Open a DOS command window by selecting **Start > Run** from the Start menu.
- Step 2** In the Open field, type **command** and then click **OK**. The DOS command window appears.

- Step 3** At the prompt in the DOS window, type **ipconfig** and press the **Enter** key.
The Windows IP configuration information appears, including the IP address, the subnet mask, and the default gateway.



Note The winipcfg command only returns the information above if you are on a network.

- Step 4** At the prompt in the DOS window, type **ping** followed by the IP address shown in the Windows IP configuration information previously displayed.
- Step 5** Press the **Enter** key to execute the command.
If the DOS window returns multiple (usually four) replies, the IP configuration is working properly.
If you do not receive a reply, your IP configuration might not be properly set. Contact your network administrator for instructions to correct the IP configuration of your PC.
-

1.6.6 Browser Login Does Not Launch Java

Symptom The message “Loading Java Applet” does not appear and the JRE does not launch during the initial login.

Possible Cause The PC operating system and browser are not properly configured.

Recommended Action Reconfigure the PC operating system Java Plug-in Control Panel and the browser settings. Complete the [“Reconfigure the PC Operating System Java Plug-in Control Panel” procedure on page 1-40](#) and the [“Reconfigure the Browser” procedure on page 1-41](#).

Reconfigure the PC Operating System Java Plug-in Control Panel

- Step 1** From the Windows start menu, click **Settings > Control Panel**.
- Step 2** If **Java Plug-in** does not appear, the JRE might not be installed on your PC:
- Run the Cisco ONS 15454 software CD.
 - Open the *CD-drive:\Windows\JRE* folder.
 - Double-click the **j2re-5_0-win** icon to run the JRE installation wizard.
 - Follow the JRE installation wizard steps.
- Step 3** From the Windows start menu, click **Settings > Control Panel**.
- Step 4** In the Java Plug-in Control Panel window, double-click the **Java Plug-in 5.0** icon.
- Step 5** Click the **Advanced** tab on the Java Plug-in Control Panel.
- Step 6** Navigate to **C:\ProgramFiles\JavaSoft\JRE\5.0**.
- Step 7** Select **JRE 5.0**.
- Step 8** Click **Apply**.

Step 9 Close the Java Plug-in Control Panel window.

Reconfigure the Browser

Step 1 From the Start Menu, launch your browser application.

Step 2 If you are using Netscape Navigator:

- a. From the Netscape Navigator menu bar, click the **Edit > Preferences** menus.
- b. In the Preferences window, click the **Advanced > Proxies** categories.
- c. In the Proxies window, click the **Direct connection to the Internet** check box and click **OK**.
- d. From the Netscape Navigator menu bar, click the **Edit > Preferences** menus.
- e. In the Preferences window, click the **Advanced > Cache** categories.
- f. Confirm that the Disk Cache Folder field shows one of the following paths:
 - For Windows 98/ME: **C:\ProgramFiles\Netscape\Communicator\cache**
 - For Windows NT/2000/XP: **C:\ProgramFiles\Netscape\username\Communicator\cache**
- g. If the Disk Cache Folder field is not correct, click **Choose Folder**.
- h. Navigate to the file listed in Step f, and click **OK**.
- i. Click **OK** in the Preferences window and exit the browser.

Step 3 If you are using Internet Explorer:

- a. From the Internet Explorer menu bar, click the **Tools > Internet Options** menus.
- b. In the Internet Options window, click the **Advanced** tab.
- c. In the Settings menu, scroll down to Java (Sun) and click the **Use Java 2 v1.4.2 for applet (requires restart)** check box.
- d. Click **OK** in the Internet Options window and exit the browser.

Step 4 Temporarily disable any virus-scanning software on the computer. See the [“1.7.4 Browser Stalls When Downloading CTC JAR Files From TCC2/TCC2P Card”](#) section on page 1-46.

Step 5 Verify that the computer does not have two network interface cards (NICs) installed. If the computer does have two NICs, remove one.

Step 6 Restart the browser and log onto the ONS 15454.

1.6.7 Unable to Verify the NIC Connection on Your PC

Symptom When connecting your PC to the ONS 15454, you are unable to verify that the NIC connection is working properly because the link LED is not illuminated or flashing.

Possible Cause The CAT-5 cable is not plugged in properly.

Recommended Action Confirm that both ends of the cable are properly inserted. If the cable is not fully inserted due to a broken locking clip, the cable should be replaced.

Possible Cause The CAT-5 cable is damaged.

Recommended Action Ensure that the cable is in good condition. If in doubt, use a known-good cable. Often, cabling is damaged due to pulling or bending. (For information about installing cable, refer to the “Install Cards and Fiber-Optic Cable” chapter in the *Cisco ONS 15454 DWDM Procedure Guide*.)

Possible Cause Incorrect type of CAT-5 cable is being used.

Recommended Action If connecting an ONS 15454 directly to your laptop, a PC, or a router, use a straight-through CAT-5 cable. When connecting the ONS 15454 to a hub or a LAN switch, use a crossover CAT-5 cable. For details on the types of CAT-5 cables, see the “1.9.2.1 Crimp Replacement LAN Cables” section on page 1-57.

Possible Cause The NIC is improperly inserted or installed.

Recommended Action If you are using a Personal Computer Memory Card International Association (PCMCIA)-based NIC, remove and reinsert the NIC to make sure the NIC is fully inserted. (If the NIC is built into the laptop or PC, verify that the NIC is not faulty.)

Possible Cause The NIC is faulty.

Recommended Action Confirm that the NIC is working properly. If you have no issues connecting to the network (or any other node), then the NIC should be working correctly. If you have difficulty connecting a to the network (or any other node), then the NIC might be faulty and needs to be replaced.

1.6.8 Verify PC Connection to the ONS 15454 (ping)

Symptom The TCP/IP connection was established and then lost.

Possible Cause A lost connection between the PC and the ONS 15454.

Recommended Action Use a standard ping command to verify the TCP/IP connection between the PC and the ONS 15454 TCC2/TCC2P card. A ping command should work if the PC connects directly to the TCC2/TCC2P card or uses a LAN to access the TCC2/TCC2P card. Complete the “Ping the ONS 15454” procedure on page 1-42.

Ping the ONS 15454

-
- Step 1** Display the command prompt:
- a. If you are using a Microsoft Windows operating system, from the Start Menu choose **Run**, enter **command** in the Open field of the Run dialog box, and click **OK**.
 - b. If you are using a Sun Solaris operating system, from the Common Desktop Environment (CDE) click the **Personal Application** tab and click **Terminal**.
- Step 2** For both the Sun and Microsoft operating systems, at the prompt enter:
- ping** *ONS-15454-IP-address*
- For example:

ping 198.168.10.10

- Step 3** If the workstation has connectivity to the ONS 15454, the ping is successful and displays a reply from the IP address. If the workstation does not have connectivity, a “Request timed out” message appears.
 - Step 4** If the ping is successful, it demonstrates that an active TCP/IP connection exists. Restart CTC.
 - Step 5** If the ping is not successful, and the workstation connects to the ONS 15454 through a LAN, check that the workstation’s IP address is on the same subnet as the ONS node.
 - Step 6** If the ping is not successful and the workstation connects directly to the ONS 15454, check that the link light on the workstation’s NIC is illuminated.
-

1.6.9 The IP Address of the Node is Unknown

Symptom The IP address of the node is unknown and you are unable to login.

Possible Cause The node is not set to the default IP address.

Recommended Action Leave one TCC2/TCC2P card in the shelf. Connect a PC directly to the remaining TCC2/TCC2P card and perform a hardware reset of the card. The TCC2/TCC2P card transmits the IP address after the reset to enable you to capture the IP address for login. Complete the [“Retrieve Unknown Node IP Address” procedure on page 1-43](#).

Retrieve Unknown Node IP Address

-
- Step 1** Connect your PC directly to the active TCC2/TCC2P card Ethernet port on the faceplate.
 - Step 2** Start the Sniffer application on your PC.
 - Step 3** Perform a hardware reset by pulling and reseating the active TCC2/TCC2P card.
 - Step 4** After the TCC2/TCC2P card completes resetting, it broadcasts its IP address. The Sniffer software on your PC will capture the IP address being broadcast.
-

1.7 CTC Operation Troubleshooting

This section contains troubleshooting procedures for CTC login or operation problems.

1.7.1 CTC Colors Do Not Appear Correctly on a UNIX Workstation

Symptom When running CTC on a UNIX workstation, the colors do not appear correctly. For example, both major and minor alarms appear in the same color.

Possible Cause When running in 256-color mode on a UNIX workstation, color-intensive applications such as Netscape might use all of the colors.

Recommended Action CTC requires a full 24-color palette to run properly. When logging into CTC on a UNIX workstation, run as many colors as your adapter will support. In addition, you can use the `-install` or the `-ncols 32` command line options to limit the number of colors that Netscape uses. Complete the [“Limit Netscape Colors” procedure on page 1-44](#). If the problem persists after limiting Netscape colors, exit any other color-intensive applications in use.

Limit Netscape Colors

- Step 1** Close the current session of Netscape.
- Step 2** Launch Netscape from the command line by entering one of the following commands:
- **netscape -install** (installs Netscape colors for Netscape use)
 - **netscape -ncols 32** (limits Netscape to 32 colors so that if the requested color is not available, Netscape chooses the closest color option)
-

1.7.2 Unable to Launch CTC Help After Removing Netscape

Symptom After removing Netscape and running CTC using Internet Explorer, you are unable to launch CTC Help and receive an “MSIE is not the default browser” error message.

Possible Cause Loss of association between browser and Help files.

Recommended Action When the CTC software and Netscape are installed, the Help files are associated with Netscape by default. When you remove Netscape, the Help files are not automatically associated with Internet Explorer as the default browser. Reset Internet Explorer as the default browser so that CTC associates the Help files to the correct browser. Complete the [“Reset Internet Explorer as the Default Browser for CTC” procedure on page 1-44](#) to associate the CTC Help files to the correct browser.

Reset Internet Explorer as the Default Browser for CTC

- Step 1** Open the Internet Explorer browser.
- Step 2** From the menu bar, click **Tools > Internet Options**. The Internet Options window appears.
- Step 3** In the Internet Options window, click the **Programs** tab.
- Step 4** Click the **Internet Explorer should check to see whether it is the default browser** check box.

- Step 5** Click **OK**.
- Step 6** Exit any and all open and running CTC and Internet Explorer applications.
- Step 7** Launch Internet Explorer and open a new CTC session. You should now be able to access the CTC Help.
-

1.7.3 Unable to Change Node View to Network View

Symptom When activating a large, multinode BLSR from Software R3.2 to Software R3.3, some of the nodes appear grayed out. Logging into the new CTC, the user is unable to change node view (single-shelf mode) or shelf view (multishelf mode) to network view on any nodes, from any workstation. This is accompanied by an “Exception occurred during event dispatching: java.lang.OutOfMemoryError” in the java window.

Possible Cause The large, multinode BLSR requires more memory for the graphical user interface (GUI) environment variables.

Recommended Action Set the system or user CTC_HEAP environment variable to increase the memory limits. Complete the “[Set the CTC_HEAP and CTC_MAX_PERM_SIZE_HEAP Environment Variables for Windows](#)” procedure on page 1-45 or the “[Set the CTC_HEAP and CTC_MAX_PERM_SIZE_HEAP Environment Variables for Solaris](#)” procedure on page 1-46 to enable the CTC_HEAP variable change.



Note This problem typically affects large networks where additional memory is required to manage large numbers of nodes and circuits.

Set the CTC_HEAP and CTC_MAX_PERM_SIZE_HEAP Environment Variables for Windows



Note Before proceeding with the following steps, ensure that your system has a minimum of 1 GB of RAM. If your system does not have a minimum of 1 GB of RAM, contact the Cisco Technical Assistance Center (TAC).

- Step 1** Close all open CTC sessions and browser windows.
- Step 2** From the Windows **Start** menu, choose **Control Panel > System**.
- Step 3** In the System Properties window, click the **Advanced** tab.
- Step 4** Click the **Environment Variables** button to open the Environment Variables window.
- Step 5** Click the **New** button under the System variables field.
- Step 6** Type CTC_HEAP in the Variable Name field.
- Step 7** Type 512 in the Variable Value field, and then click the **OK** button to create the variable.
- Step 8** Again, click the **New** button under the System variables field.
- Step 9** Type CTC_MAX_PERM_SIZE_HEAP in the Variable Name field.
- Step 10** Type 128 in the Variable Value field, and then click the **OK** button to create the variable.

- Step 11** Click the **OK** button in the Environment Variables window to accept the changes.
- Step 12** Click the **OK** button in the System Properties window to accept the changes.
-

Set the CTC_HEAP and CTC_MAX_PERM_SIZE_HEAP Environment Variables for Solaris

- Step 1** From the user shell window, kill any CTC sessions and browser applications.
- Step 2** In the user shell window, set the environment variables to increase the heap size.

Example

The following example shows how to set the environment variables in the C shell:

```
% setenv CTC_HEAP 512
% setenv CTC_MAX_PERM_SIZE_HEAP 128
```

1.7.4 Browser Stalls When Downloading CTC JAR Files From TCC2/TCC2P Card

Symptom The browser stalls or hangs when downloading a CTC Java archive (JAR) file from the TCC2/TCC2P card.

Possible Cause McAfee VirusScan software might be interfering with the operation. The problem occurs when the VirusScan Download Scan is enabled on McAfee VirusScan 4.5 or later.

Recommended Action Disable the VirusScan Download Scan feature. Complete the [“Disable the VirusScan Download Scan”](#) procedure on page 1-46.

Disable the VirusScan Download Scan

- Step 1** From the Windows Start menu, choose **Programs > Network Associates > VirusScan Console**.
- Step 2** Double-click the **VShield** icon listed in the VirusScan Console dialog box.
- Step 3** Click **Configure** on the lower part of the Task Properties window.
- Step 4** Click the **Download Scan** icon on the left of the System Scan Properties dialog box.
- Step 5** Uncheck the **Enable Internet download scanning** check box.
- Step 6** Click **Yes** when the warning message appears.
- Step 7** Click **OK** in the System Scan Properties dialog box.
- Step 8** Click **OK** in the Task Properties window.
- Step 9** Close the McAfee VirusScan window.
-

1.7.5 CTC Does Not Launch

Symptom CTC does not launch; usually an error message appears before the login window appears.

Possible Cause The Netscape browser cache might point to an invalid directory.

Recommended Action Redirect the Netscape cache to a valid directory. Complete the [“Redirect the Netscape Cache to a Valid Directory” procedure on page 1-47](#).

Redirect the Netscape Cache to a Valid Directory

- Step 1** Launch Netscape.
- Step 2** Open the **Edit** menu.
- Step 3** Choose **Preferences**.
- Step 4** In the Category column on the left side, expand the **Advanced** category and choose the **Cache** tab.
- Step 5** Change your disk cache folder to point to the cache file location.

The cache file location is usually C:\ProgramFiles\Netscape\Users\yourname\cache. The *yourname* segment of the file location is often the same as the user name.

1.7.6 Slow CTC Operation or Login Problems

Symptom You experience slow CTC operation or have problems logging into CTC.

[Table 1-5](#) describes the potential cause of the symptom and the solution.

Table 1-5 *Slow CTC Operation or Login Problems*

Possible Problem	Solution
The CTC cache file might be corrupted or might need to be replaced.	Search for and delete cache files. This operation forces the ONS 15454 to download a new set of Java archive (JAR) files to your computer hard drive. Complete the “Delete the CTC Cache File Automatically” procedure on page 1-48 or the “Delete the CTC Cache File Manually” procedure on page 1-49 .
Insufficient heap memory allocation.	<p>Increase the heap size if you are using CTC to manage more than 50 nodes concurrently. See the “Set the CTC_HEAP and CTC_MAX_PERM_SIZE_HEAP Environment Variables for Windows” procedure on page 1-45 or the “Set the CTC_HEAP and CTC_MAX_PERM_SIZE_HEAP Environment Variables for Solaris” procedure on page 1-46.</p> <p>Note To avoid network performance issues, Cisco recommends managing a maximum of 50 nodes concurrently with CTC. To manage more than 50 nodes, Cisco recommends using Cisco Transport Manager (CTM). Cisco does not recommend running multiple CTC sessions when managing two or more large networks.</p>

Delete the CTC Cache File Automatically



Caution

All running sessions of CTC must be halted before deleting the CTC cache. Deleting the CTC cache might cause any CTC running on this system to behave in an unexpected manner.

-
- Step 1** Enter an ONS 15454 IP address into the browser URL field. The initial browser window shows a **Delete CTC Cache** button.
- Step 2** Close all open CTC sessions and browser windows. The PC operating system does not allow you to delete files that are in use.
- Step 3** Click **Delete CTC Cache** in the initial browser window to clear the CTC cache. [Figure 1-17](#) shows the Delete CTC Cache window.

Figure 1-17 Deleting the CTC Cache

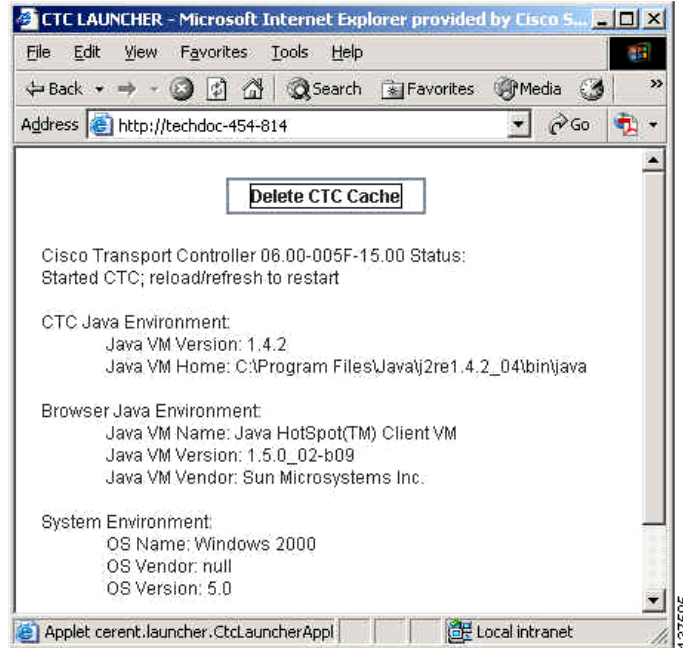

Delete the CTC Cache File Manually



Caution

All running sessions of CTC must be halted before deleting the CTC cache. Deleting the CTC cache might cause any CTC running on this system to behave in an unexpected manner.

- Step 1** To delete the JAR files manually, from the Windows Start menu choose **Search > For Files or Folders**.
- Step 2** In the Search Results dialog box, enter **ctc*.jar** or **cms*.jar** in the Search for Files or Folders Named field and click **Search Now**.
- Step 3** Click the **Modified** column in the Search Results dialog box to find the JAR files that match the date when you downloaded the files from the TCC2/TCC2P.
- Step 4** Highlight the files and press the keyboard **Delete** key.
- Step 5** Click **Yes** in the Confirm dialog box.

1.7.7 Node Icon is Gray on CTC Network View

Symptom The CTC network view shows one or more node icons as gray in color and without a node name.

Possible Cause Different CTC releases do not recognize each other.

Recommended Action Correct the core version build as described in the [“1.7.9 Different CTC Releases Do Not Recognize Each Other”](#) section on page 1-51.

Possible Cause Username and password do not match.

Recommended Action Correct the username and password as described in the [“1.7.10 Username or Password Do Not Match”](#) section on page 1-52.

Possible Cause A lost DCC connection.

Recommended Action Usually accompanied by an embedded operations channel (EOC) alarm. Clear the EOC alarm and verify the DCC connection as described in the [“EOC”](#) alarm.

1.7.8 Java Runtime Environment Incompatible

Symptom The CTC application does not run properly.

Possible Cause The compatible Java 2 JRE is not installed.

Recommended Action The JRE contains the Java virtual machine, runtime class libraries, and Java application launcher that are necessary to run programs written in the Java programming language. The ONS 15454 CTC is a Java application. A Java application, unlike an applet, cannot rely completely on a web browser for installation and runtime services. When you run an application written in the Java programming language, you need the correct JRE installed. The correct JRE for each CTC software release is included on the Cisco ONS 15454 software CD. Complete the [“Launch CTC to Correct the Core Version Build”](#) procedure on page 1-51. If you are running multiple CTC software releases on a network, the JRE installed on the computer must be compatible with the different software releases. [Table 1-6](#) shows JRE compatibility with ONS 15454 software releases.

Table 1-6 JRE Compatibility

Software Release	JRE 1.2.2 Compatible	JRE 1.3 Compatible	JRE 1.4 Compatible ¹	JRE 5.0 Compatible
ONS 15454 R2.2.1 and earlier	Yes	No	No	No
ONS 15454 R2.2.2	Yes	Yes	No	No
ONS 15454 R3.0	Yes	Yes	No	No
ONS 15454 R3.1	Yes	Yes	No	No
ONS 15454 R3.2	Yes	Yes	No	No
ONS 15454 R3.3	Yes	Yes	No	No

Table 1-6 JRE Compatibility (continued)

Software Release	JRE 1.2.2 Compatible	JRE 1.3 Compatible	JRE 1.4 Compatible ¹	JRE 5.0 Compatible
ONS 15454 R3.4	No	Yes	No	No
ONS 15454 R4.0 ²	No	Yes	No	No
ONS 15454 R4.1	No	Yes	No	No
ONS 15454 R4.5	No	Yes	No	No
ONS 15454 R4.6	No	Yes	Yes	No
ONS 15454 R4.7	No	Yes	Yes	No
ONS 15454 R5.0	No	Yes	Yes	No
ONS 15454 R6.0	No	No	Yes	No
ONS 15454 R7.0	No	No	No	Yes
ONS 15454 R8.5	No	No	No	Yes
ONS 15454 R9.0	No	No	No	Yes

1. JRE 1.4.2 is the recommended version and is provided on the software CD.
2. Software Release 4.0 notifies you if an earlier JRE version is running on your PC or UNIX workstation.

Launch CTC to Correct the Core Version Build

-
- Step 1** Exit the current CTC session and completely close the browser.
 - Step 2** Start the browser.
 - Step 3** Enter the ONS 15454 IP address of the node that reported the alarm. This can be the original IP address you logged in with or an IP address other than the original.
 - Step 4** Log into CTC. The browser downloads the JAR file from CTC.
-

1.7.9 Different CTC Releases Do Not Recognize Each Other

Symptom Different CTC releases do not recognize each other. This situation is often accompanied by the INCOMPATIBLE-SW alarm.

Possible Cause The software loaded on the connecting workstation and the software on the TCC2/TCC2P card are incompatible.

Recommended Action This occurs when the TCC2/TCC2P software is upgraded but the PC has not yet upgraded the compatible CTC JAR file. It also occurs on login nodes with compatible software that encounter other nodes in the network that have a newer software version. Complete the [“Launch CTC to Correct the Core Version Build” procedure on page 1-52](#).



Note Remember to always log into the ONS node with the latest CTC core version first. If you initially log into an ONS node running a CTC core version of 2.2 or lower and then attempt to log into another ONS node in the network running a higher CTC core version, the lower version node does not recognize the new node.

Launch CTC to Correct the Core Version Build

-
- Step 1** Exit the current CTC session and completely close the browser.
 - Step 2** Start the browser.
 - Step 3** Enter the ONS 15454 IP address of the node that reported the alarm. This can be the original IP address you logged on with or an IP address other than the original.
 - Step 4** Log into CTC. The browser downloads the JAR file from CTC.
-

1.7.10 Username or Password Do Not Match

Symptom A username/password mismatch often occurs concurrently with a NOT-AUTHENTICATED alarm.

Possible Cause The username or password entered does not match the information stored in the TCC2/TCC2P card.

Recommended Action All ONS nodes must have the same username and password created to display every ONS node in the network. You can also be locked out of certain ONS nodes on a network if your username and password were not created on those specific ONS nodes. For initial login to the ONS 15454, enter the CISCO15 user name in capital letters, click **Login**, and use the password **otbu+1**, which is case-sensitive.

Complete the [“Verify Correct Username and Password” procedure on page 1-52](#). If the node has been configured for Remote Authentication Dial In User Service (RADIUS) authentication, the username and password are verified against the RADIUS server database rather than the security information in the local node database. For more information about RADIUS security, refer to the “Security Reference” chapter in the *Cisco ONS 15454 DWDM Reference Manual*.

Verify Correct Username and Password

-
- Step 1** Ensure that your keyboard Caps Lock key is not turned on and affecting the case-sensitive entry of the username and password.
 - Step 2** Contact your system administrator to verify the username and password.
 - Step 3** Call Cisco Technical Support (1-800-553-2447) to have them enter your system and create a new user name and password.
-

1.7.11 DCC Connection Lost

Symptom DCC connection is lost. The node usually has alarms and the nodes in the network view have a gray icon. This symptom is usually accompanied by an EOC alarm.

Possible Cause A lost DCC connection.

Recommended Action Usually accompanied by an EOC alarm. Clear the EOC alarm and verify the DCC connection as described in the “EOC” alarm.

1.7.12 “Path in Use” Error When Creating a Circuit

Symptom While creating a circuit, you get a “Path in Use” error that prevents you from completing the circuit creation.

Possible Cause Another user has already selected the same source port to create another circuit.

Recommended Action CTC does not remove a card or port from the available list until a circuit is completely provisioned. If two users simultaneously select the same source port to create a circuit, the first user to complete circuit provisioning gets use of the port. The other user gets the “Path in Use” error. Cancel the circuit creation and start over, or click **Back** until you return to the initial circuit creation window. The source port that was previously selected no longer appears in the available list because it is now part of a provisioned circuit. Select a different available port and begin the circuit creation process again.

1.7.13 Calculate and Design IP Subnets

Symptom You cannot calculate or design IP subnets on the ONS 15454.

Possible Cause The IP capabilities of the ONS 15454 require specific calculations to properly design IP subnets.

Recommended Action Cisco provides a free online tool to calculate and design IP subnets. Go to http://www.cisco.com/techtools/ip_addr.html. For information about ONS 15454 IP capability, refer to the “Management Network Connectivity” chapter in the *Cisco ONS 15454 DWDM Reference Manual*.

1.8 Timing

This section provides solutions to common timing reference errors and alarms.

1.8.1 ONS 15454 Switches Timing Reference

Symptom Timing references switch when one or more problems occur.

Possible Cause The optical or building integrated timing supply (BITS) input is receiving loss of signal (LOS), loss of frame (LOF), or AIS alarms from its timing source.

Possible Cause The optical or BITS input is not functioning.

Possible Cause The synchronization status messaging (SSM) message is set to do not use for synchronization (DUS).

Possible Cause SSM indicates a Stratum 3 or lower clock quality.

Possible Cause The input frequency is off by more than 15 ppm.

Possible Cause The input clock wanders and has more than three slips in 30 seconds.

Possible Cause A bad timing reference existed for at least two minutes.

Recommended Action The ONS 15454 internal clock operates at a Stratum 3E level of accuracy. This gives the ONS 15454 a free-running synchronization accuracy of ± 4.6 ppm and a holdover stability of less than 255 slips in the first 24 hours or 3.7×10^{-7} /day, including temperature. ONS 15454 free-running synchronization relies on the Stratum 3 internal clock. Over an extended time period, using a higher quality Stratum 1 or Stratum 2 timing source results in fewer timing slips than a lower quality Stratum 3 timing source.

1.8.2 Holdover Synchronization Alarm

Symptom The clock is running at a different frequency than normal and the “[HLDOVRSYNC](#)” alarm appears.

Possible Cause The last reference input has failed.

Recommended Action The clock is running at the frequency of the last known-good reference input. This alarm is raised when the last reference input fails. See the “[HLDOVRSYNC](#)” alarm on [page 2-102](#) for a detailed description.



Note The ONS 15454 supports holdover timing per Telcordia GR-436 when provisioned for external (BITS) timing.

1.8.3 Free-Running Synchronization Mode

Symptom The clock is running at a different frequency than normal and the “FRNGSYNC” alarm appears.

Possible Cause No reliable reference input is available.

Recommended Action The clock is using the internal oscillator as its only frequency reference. This occurs when no reliable, prior timing reference is available. See the “FRNGSYNC” alarm on [page 2-88](#) for a detailed description.

1.8.4 Daisy-Chaind BITS Not Functioning

Symptom You are unable to daisy chain the BITS sources.

Possible Cause Daisy-chained BITS sources are not supported on the ONS 15454.

Recommended Action Daisy-chained BITS sources cause additional wander buildup in the network and are therefore not supported. Instead, use a timing signal generator to create multiple copies of the BITS clock and separately link them to each ONS 15454.

1.8.5 Blinking STAT LED after Installing a Card

Symptom After installing a card, the STAT LED blinks continuously for more than 60 seconds.

Possible Cause The card cannot boot because it failed the Power On Shelf Test (POST) diagnostics.

Recommended Action The blinking STAT LED indicates that POST diagnostics are being performed. If the LED continues to blink for more than 60 seconds, the card has failed the POST diagnostics test and has failed to boot. If the card has truly failed, an “EQPT” alarm is raised against the slot number with an “Equipment Failure” description. Check the alarm tab for this alarm to appear for the slot where the card was installed. To attempt recovery, remove and reinstall the card and observe the card boot process. If the card fails to boot, replace the card. Complete the “[Physically Replace a Card](#)” procedure on [page 2-244](#).



Warning

High-performance devices on this card can get hot during operation. To remove the card, hold it by the faceplate and bottom edge. Allow the card to cool before touching any other part of it or before placing it in an antistatic bag. Statement 201



Caution

Removing a card that currently carries traffic on one or more ports can cause a traffic hit. To avoid this, perform an external switch if a switch has not already occurred. Refer to the procedures in the “[2.8.2 Protection Switching, Lock Initiation, and Clearing](#)” section on [page 2-237](#). For more information, refer to the “Maintain the Node” chapter in the *Cisco ONS 15454 DWDM Procedure Guide*.

1.9 Fiber and Cabling

This section explains problems typically caused by cabling connectivity errors. It also includes instructions for crimping CAT-5 cable and lists the optical fiber connectivity levels.

1.9.1 Bit Errors Appear for a Traffic Card

Symptom A traffic card has multiple bit errors.

Possible Cause Faulty cabling or low optical-line levels.

Recommended Action Bit errors on line (traffic) cards usually originate from cabling problems or low optical-line levels. The errors can be caused by synchronization problems, especially if pointer justification (PJ) errors are reported. Moving cards into different error-free slots will isolate the cause. Use a test set whenever possible because the cause of the errors could be external cabling, fiber, or external equipment connecting to the ONS 15454. Troubleshoot low optical levels using the “[1.9.2 Faulty Fiber-Optic Connections](#)” section on page 1-56.

1.9.2 Faulty Fiber-Optic Connections

Symptom A card has multiple alarms and/or signal errors.

Possible Cause Faulty fiber-optic connections. Fiber connection problems usually occur in conjunction with alarms.

Recommended Action Refer to the appropriate trouble-clearing procedure in [Chapter 2, “Alarm Troubleshooting.”](#)

Possible Cause Faulty CAT-5 cables.

Recommended Action Faulty CAT-5 cables can be the source of alarms and signal errors. Complete the “[1.9.2.1 Crimp Replacement LAN Cables](#)” section on page 1-57.

Possible Cause Faulty Gigabit Interface Converters (GBICs).

Recommended Action Faulty GBICs can be the source of alarms and signal errors. See the “[1.9.2.2 Replace Faulty SFP or XFP Connectors](#)” section on page 1-58.



Warning

Invisible laser radiation may be emitted from disconnected fibers or connectors. Do not stare into beams or view directly with optical instruments. Statement 272



Warning

Laser radiation presents an invisible hazard, so personnel should avoid exposure to the laser beam. Personnel must be qualified in laser safety procedures and must use proper eye protection before working on this equipment. Statement 300

1.9.2.1 Crimp Replacement LAN Cables

You can crimp your own LAN cables for use with the ONS 15454. Use a cross-over cable when connecting an ONS 15454 to a hub, LAN modem, or switch, and use a LAN cable when connecting an ONS 15454 to a router or workstation. Use CAT-5 cable RJ-45 T-568B, Color Code (100 Mbps), and a crimping tool. Figure 1-18 shows the wiring of an RJ-45 connector. Figure 1-19 shows a LAN cable layout, and Table 1-7 shows the cable pinouts. Figure 1-20 shows a cross-over cable layout, and Table 1-8 shows the cross-over pinouts.

Figure 1-18 RJ-45 Pin Numbers

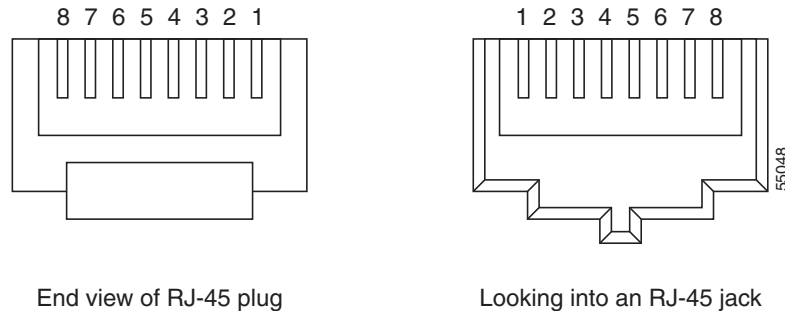

Figure 1-19 LAN Cable Layout

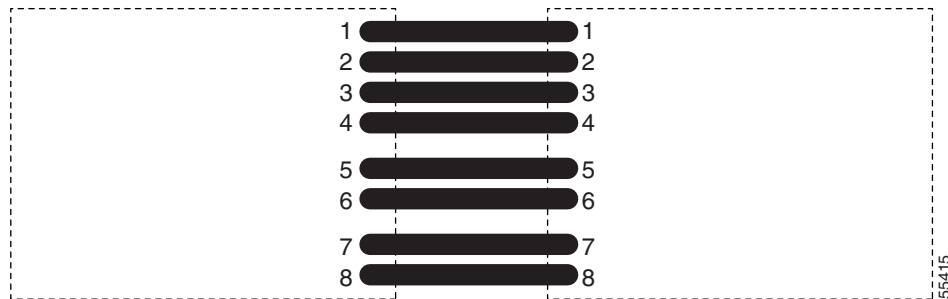

Table 1-7 LAN Cable Pinout

Pin	Color	Pair	Name	Pin
1	white/orange	2	Transmit Data +	1
2	orange	2	Transmit Data -	2
3	white/green	3	Receive Data +	3
4	blue	1	—	4
5	white/blue	1	—	5
6	green	3	Receive Data -	6
7	white/brown	4	—	7
8	brown	4	—	8

Figure 1-20 Cross-Over Cable Layout

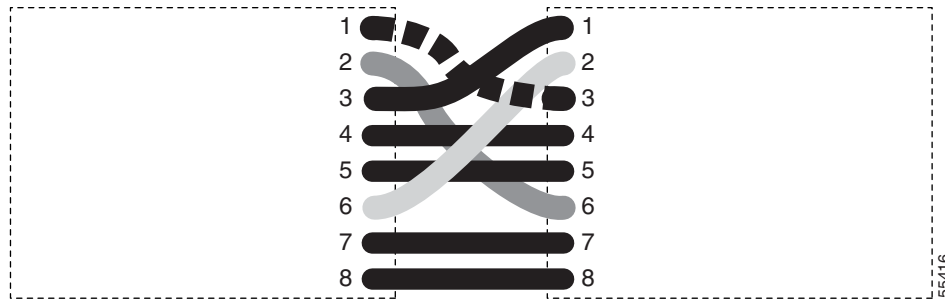

Table 1-8 Cross-Over Cable Pinout

Pin	Color	Pair	Name	Pin
1	white/orange	2	Transmit Data +	3
2	orange	2	Transmit Data –	6
3	white/green	3	Receive Data +	1
4	blue	1	—	4
5	white/blue	1	—	5
6	green	3	Receive Data –	2
7	white/brown	4	—	7
8	brown	4	—	8

**Note**

Odd-numbered pins always connect to a white wire with a colored stripe.

1.9.2.2 Replace Faulty SFP or XFP Connectors

Small Form-factor Pluggables (SFPs) and 10-Gbps SFPs (called XFPs) are input/output devices that plug into some DWDM cards to link the port with the fiber-optic network. The type of SFP or XFP determines the maximum distance that traffic can travel from the card to the next network device. For a description of SFPs and XFPs and their capabilities, refer to the *Cisco ONS 15454 DWDM Reference Manual*. SFPs and XFPs are hot-swappable and can be installed or removed while the card or shelf assembly is powered and running.

**Warning**

Class 1 laser product. Statement 1008

**Warning**

Invisible laser radiation may be emitted from disconnected fibers or connectors. Do not stare into beams or view directly with optical instruments. Statement 272

**Note**

SFPs and XFPs must be matched on both ends by type: SX to SX, LX to LX, or ZX to ZX.

Remove SFP or XFP Connectors



Warning

Invisible laser radiation may be emitted from disconnected fibers or connectors. Do not stare into beams or view directly with optical instruments. Statement 272

-
- Step 1** Disconnect the network fiber cable from the SFP or XFP LC duplex connector.
 - Step 2** Release the SFP or XFP from the slot by simultaneously squeezing the two plastic tabs on each side.
 - Step 3** Slide the SFP out of the card slot. A flap closes over the SFP slot to protect the connector on the card.
-

Install an SFP or XFP Connector



Warning

Class 1 laser product. Statement 1008



Warning

Invisible laser radiation could be emitted from the end of the unterminated fiber cable or connector. Do not stare into the beam directly with optical instruments. Viewing the laser output with certain optical instruments (for example, eye loupes, magnifiers, and microscopes) within a distance of 100 mm could pose an eye hazard. Statement 1056

-
- Step 1** Remove the SFP or XFP from its protective packaging.
 - Step 2** Check the label to verify that you are using a compatible SFP or XFP for the card where you want to install the connector. For a list of the SFPs and XFPs that are compatible with each card, refer to the “Transponder and Muxponder Cards” chapter in the *Cisco ONS 15454 DWDM Reference Manual*.
 - Step 3** Plug the LC duplex connector of the fiber into a Cisco-supported SFP or XFP.
 - Step 4** If the new SFP or XFP has a latch, close the latch over the cable to secure it.
 - Step 5** Plug the cabled SFP or XFP into the card port until it clicks.

To change the payload type of an SFP or XFP (called pluggable port modules [PPMs] in CTC), refer to the “Provision Transponder and Muxponder Cards” chapter in the *Cisco ONS 15454 DWDM Procedure Guide*.

1.10 Power Supply Problems

This section explains problems related to loss of power or power supply low voltage.

Symptom Loss of power or low voltage, resulting in a loss of traffic and causing the LCD clock to reset to the default date and time.

Possible Cause Loss of power or low voltage.

Possible Cause Improperly connected power supply.

Recommended Action The ONS 15454 requires a constant source of DC power to properly function. Input power is -48 VDC. Power requirements range from -42 VDC to -57 VDC. A newly installed ONS 15454 that is not properly connected to its power supply does not operate. Power problems can be confined to a specific ONS 15454 or affect several pieces of equipment on the site. A loss of power or low voltage can result in a loss of traffic and causes the LCD clock on the ONS 15454 to default to January 1, 1970, 00:04:15. To reset the clock, in node view (single-shelf mode) or shelf view (multishelf mode) click the **Provisioning > General > General** tab and change the Date and Time fields. Complete the [“Isolate the Cause of Power Supply Problems” procedure on page 1-60](#).



Warning

Only trained and qualified personnel should be allowed to install, replace, or service this equipment.
Statement 1030



Warning

During this procedure, wear grounding wrist straps to avoid ESD damage to the card. Do not directly touch the backplane with your hand or any metal tool, or you could shock yourself. Statement 94



Caution

Operations that interrupt power supply or short the power connections to the ONS 15454 are service-affecting.

Isolate the Cause of Power Supply Problems

-
- Step 1** If a single ONS 15454 show signs of fluctuating power or power loss:
- a. Verify that the -48 VDC #8 power terminals are properly connected to a fuse panel. These power terminals are located on the lower section of the backplane EIA under the clear plastic cover.
 - b. Verify that the power cable is #10 AWG and in good condition.
 - c. Verify that the power cable connections are properly crimped. Stranded #10 AWG does not always crimp properly with Staycon type connectors.
 - d. Verify that 20-A fuses are used in the fuse panel.
 - e. Verify that the fuses are not blown.
 - f. Verify that a rack-ground cable attaches to the frame-ground terminal (FGND) on the right side of the ONS 15454 EIA. Connect this cable to the ground terminal according to local site practice.
 - g. Verify that the DC power source has enough capacity to carry the power load.
 - h. If the DC power source is battery-based:
 - Check that the output power is high enough. Power requirements range from -40.5 VDC to -57 VDC.
 - Check the age of the batteries. Battery performance decreases with age.
 - Check for opens and shorts in batteries, which might affect power output.

- If brownouts occur, the power load and fuses might be too high for the battery plant.
- Step 2** If multiple pieces of site equipment show signs of fluctuating power or power loss:
- a. Check the uninterruptible power supply (UPS) or rectifiers that supply the equipment. Refer to the UPS manufacturer's documentation for specific instructions.
 - b. Check for excessive power drains caused by other equipment, such as generators.
 - c. Check for excessive power demand on backup power systems or batteries when alternate power sources are used.
-

1.11 Power Up Problems for Node and Cards

This section explains power up problems in a node or cards typically caused an improper power supply.

Symptom You are unable to power up a node or the cards in a node.

Possible Cause Improper power supply.

Recommended Action Refer to the power information in the “Hardware Specifications” appendix of the *Cisco ONS 15454 DWDM Reference Manual*.

1.12 Network Level (Internode) Problems

The following network-level troubleshooting is discussed in this section:

- Fiber cut detection
- System restart after a fiber cut
- OCHNC circuit creation failure

1.12.1 Fiber Cut Detection

A fiber cut is one of the most disruptive faults for a DWDM system because more than one channel is potentially affected. Fault isolation must, therefore, be quick and effective.

In the Multi-Service Transport Platform (MSTP), a dedicated alarm is unambiguously associated with the detection of a fiber cut. The alarm is LOS (OTS or AOTS) and can be raised only by the two cards (OPT-BST and OSC-CSM) that directly interface to the span fiber. The LOS (OTS or AOTS) alarm is associated with the physical LINE-RX port of the OPT-BST and OSC-CSM cards (in CTC, identified by Port 5 on the OPT-BST and Port 4 on the OSC-CSM). LOS (OTS or AOTS) is the combination of the two alarms LOS-P (OTS or AOTS) (applies to channel payload) and LOS-O (applies to the OC-3 overhead OSC signal).

The simultaneous failure of both the active channel (C band) and the service channel (1510 nm) coming into the node is evidence of a fiber span issue, whereas either the LOS-P (OTS or AOTS) alarm alone or the LOS-O alarm alone can only be derived from different root causes.

**Note**

When a fiber cut occurs, the actual conditions on the affected span (for example, alarms raised on both line directions) are strictly dependent on the network automatic laser shutdown (ALS) setting. The network ALS setting is a function of the ALS mode configured on the appropriate cards in the system (OPT-BST, OPT-BST-E, OPT-BST-L, OPT-AMP-L, OPT-AMP-C, OPT-AMP-17C, OSC-CSM, and OSCM).

Different symptoms and scenarios can occur, depending on the network ALS settings. Consider the linear network (four nodes) in [Figure 1-21](#) as a reference. The scenarios are presented after the figure.

Figure 1-21 Linear Network, With No Fiber Cut

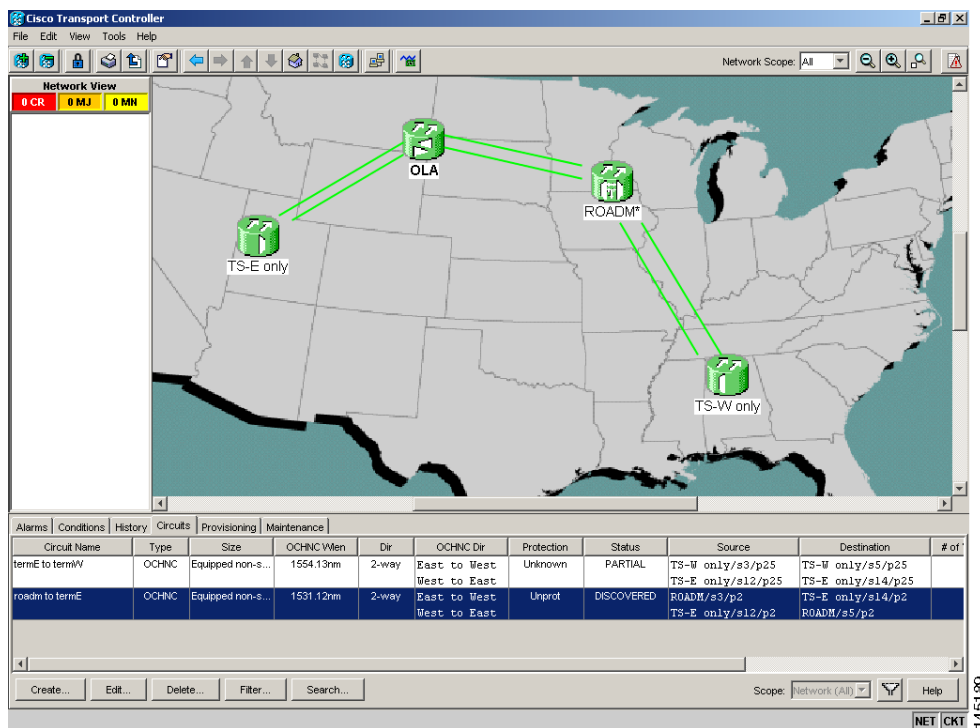

1.12.1.1 Scenario A

Scenario A has the following conditions:

- ALS Mode = Auto Restart on OPT-BST (+ OSCM) and OSC-CSM
- Fiber cut on the fiber between the OLA-TX node and the ROADM-RX node

The ALS protocol (refer to the “Network Optical Safety—Automatic Laser Shutdown” section in the “Network Reference” chapter of the *Cisco ONS 15454 DWDM Reference Manual*) is activated in the event of a fiber cut, resulting in the shutdown of optical power on both of the fibers belonging to the affected span, even if only one of the two fibers is cut.

The final fault condition of the network is shown in [Figure 1-22](#).

Figure 1-22 Fiber Cut with ALS MODE = Auto Restart

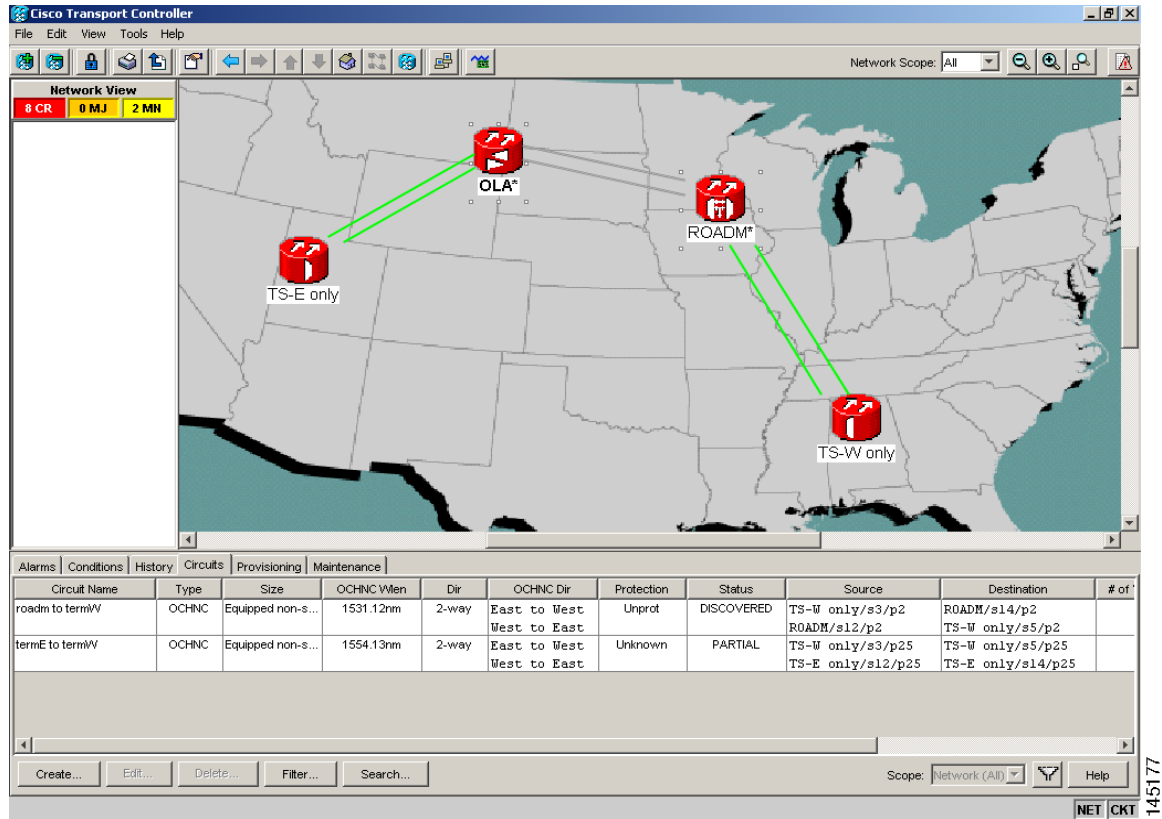

In network view, both of the lines representing the span were formerly green and have now changed to gray. Notice also that the status of all the OCHNC circuits on the broken span have changed from Discovered to Partial.

In node view (single-shelf mode) or shelf view (multishelf mode), the alarm panel of the two nodes (reconfigurable optical add/drop multiplexing [ROADM] and optical line amplification [OLA] in the example) show the LOS (AOTS) alarm on Port 4 of the OSC-CSM (see Figure 1-23) and the LOS (OTS) on Port 5 of the OPT-BST (see Figure 1-24).

Figure 1-23 LOS Indication on the ROADM Node OSC-CSM

The screenshot displays the OLA - Cisco Transport Controller interface. On the left, the OLA configuration is shown with the following details:

- 1 CR
- 9 MJ
- 1 MH
- IP Addr : 10.58.46.96
- Booted : 6/21/05 12:09 PM
- User : CISCO15
- Authority : Superuser
- SW Version: 05.02-005C-26.23
- Defaults : Factory Defaults
- APC state : Enable

The central part of the interface shows a ROADM node diagram with slots 1 through 17. Slot 17 is highlighted in red, indicating a Loss of Signal (LOS) condition. The diagram also shows various components like OSC CSM, OPT PNE, TCC2, and LAM.

At the bottom, the Alarms table is visible, showing the following active alarms:

Num	Ref	New	Date	Object	Eqpt Type	Slot	Port /	Pa...	Sev	ST	SA	Cond	Description
156	156		06/24/05 16:13:50 CEST	LINE-17-2-RX	OSC + Combiner/Sep...	17	4		CR	R	✓	LOS	Loss Of Signal
159	159		06/24/05 16:13:58 CEST	FAC-17-1	OSC + Combiner/Sep...	17	1		MN	R		EOC	SDCC Termination Failure

Buttons at the bottom include Synchronize, Filter..., Delete Cleared Alarms, and AutoDelete Cleared Alarms. A Help button is also present.

145178

NET CKT

Figure 1-24 LOS Indication on the OLA Node OPT-BST

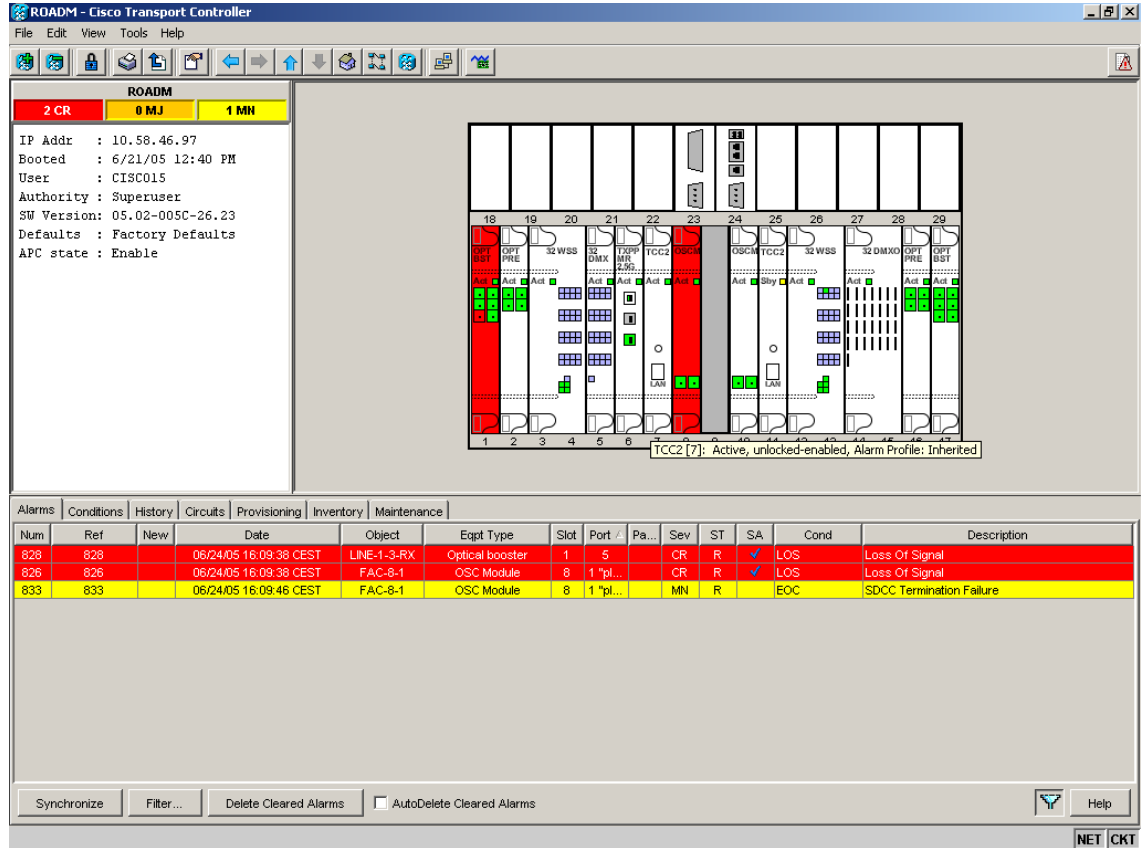

Note

An EOC condition is always present on both nodes, because the optical service channel (OSC) link (to which the communication channel applies) is down.



Note

For the OSCM card, only an LOS (OC-3) alarm is present at the SONET layer (Port 1).

1.12.1.2 Scenario B

Scenario B has the following conditions:

- ALS Mode = DISABLE on OPT-BST (+ OSCM) and OSC-CSM
- Fiber cut on the fiber between the OLA-TX node and the ROADM-RX node

Because the ALS protocol is disabled, the signal is lost on only the affected fiber (power is not shut down on both fibers).

The LOS (OTS or AOTS) alarm is raised by the ROADM-RX node that was receiving the signal coming from the broken fiber. The final fault condition of the network is shown in [Figure 1-25](#).

Figure 1-25 Network View Fault Condition for Fiber Cut with ALS Mode Disabled

The screenshot shows the Cisco Transport Controller interface in Network View. The map displays a network topology with nodes OLA, ROADM, TS-E only, and TS-W only. A fiber link between OLA and ROADM is highlighted in gray, indicating a fault. A tooltip for this link shows: "OLA/s17/p5 - ROADM/s1/p5, Optical Direction: West to East, Optical Ring Name: 1, Measured Span Loss: N/A, Expected Min Span Loss: 15.0, Expected Max Span Loss: 17.0".

The left-hand panel shows details for the OLA node:

```

OLA
CTC (login) host
Topology host
Critical : 0
Major   : 0
Minor   : 1

```

The bottom table shows circuit information:

Circuit Name	Type	Size	OCHNC Wlen	Dir	OCHNC Dir	Protection	Status	Source	Destination	# of
roadm to termW	OCHNC	Equipped non-s...	1531.12nm	2-way	East to West West to East	Unprot	DISCOVERED	TS-W only/s3/p2 ROADM/s12/p2	ROADM/s14/p2 TS-W only/s5/p2	
termE to termW	OCHNC	Equipped non-s...	1554.13nm	2-way	East to West West to East	Unknown	PARTIAL	TS-W only/s3/p25 TS-E only/s12/p25	TS-W only/s5/p25 TS-E only/s14/p25	

In network view (Figure 1-25), only the actual affected fiber becomes gray, whereas the traffic (and OSC signal as well) on the good fiber is active and fault identification is immediate.

In node view (single-shelf mode) or shelf view (multishelf mode) (Figure 1-26 and Figure 1-27), the alarm panel of the receiving node (ROADM in this example) reports the LOS (OTS), while the transmitting node (OLA) reports only an EOC alarm.

Figure 1-26 ONS 15454 SDH ROADM Node View with Fault Condition for ALS MODE Disabled

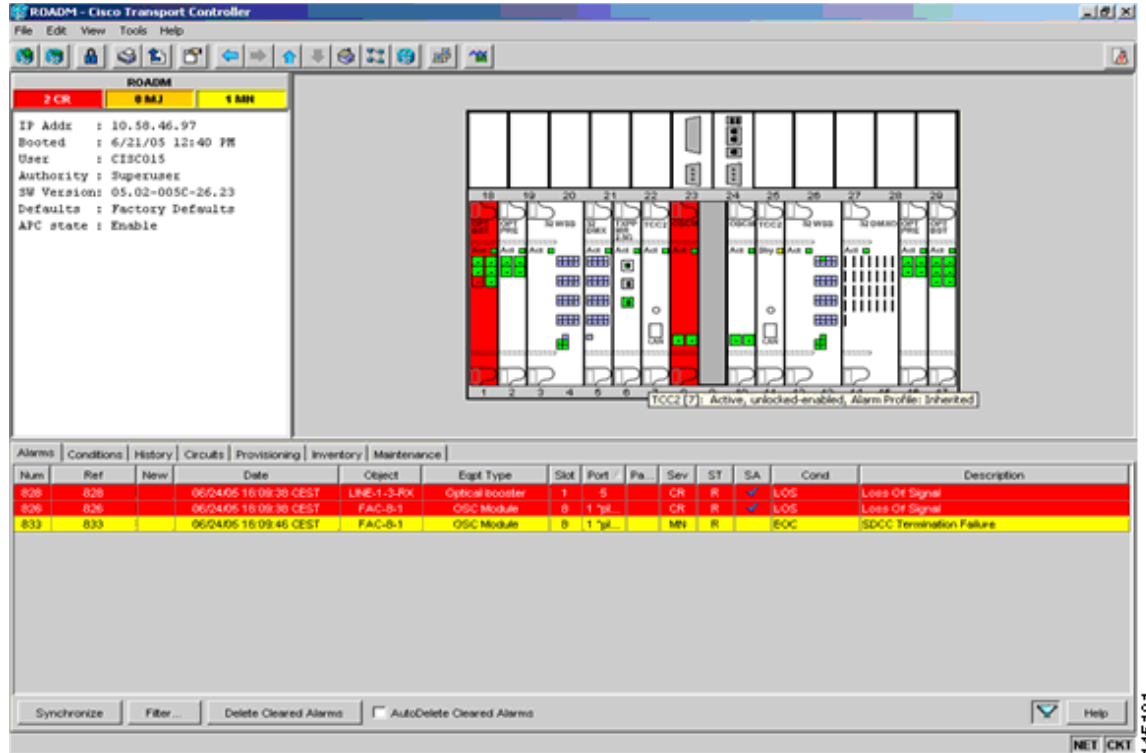

145181

Figure 1-27 ONS 15454 SDH OLA Node View with Fault Condition for ALS MODE Disabled

The screenshot shows the OLA - Cisco Transport Controller interface. The top left pane displays system information:

```

OLA
0 CR 0 MJ 1 MN
IP Addr : 10.58.46.96
Booted : 6/21/05 12:09 PM
User : CISC015
Authority : Superuser
SW Version: 05.02-005C-26.23
Defaults : Factory Defaults
APC state : Enable

```

The main area shows a rack of 29 slots. Slots 18, 19, 22, 23, 24, 25, 26, 27, 28, and 29 are populated with components. Slot 17 is highlighted in yellow, indicating a fault condition.

The Alarms table at the bottom shows the following entry:

Num	Ref	New	Date	Object	Eqpt Type	Slot	Port	Pa...	Sev	ST	SA	Cond	Description
159	159		06/24/05 16:13:58 CEST	FAC-17-1	OSC + Combiner/Sep...	17	1		MN	R		EOC	SDCC Termination Failure

In order to troubleshoot and eventually fix a fiber cut, follow the “[Fix a Fiber Cut](#)” procedure on [page 1-68](#). The basic assumption is that the MSTP system was already installed and working correctly before the alarm condition occurred. For first installation or restart from a fiber cut, refer to [1.12.2 System Restart after a Fiber Cut](#), [page 1-70](#).

Fix a Fiber Cut



Caution

When the network ALS setting is DISABLE, optical power is still present at the damaged fiber. Before fixing the span, it is highly recommended that you shut down the amplifier and the OSC laser upstream of the fiber cut.

Step 1 Isolate the span affected by the fiber cut.

- a. Go to CTC network view.
- b. Identify the span connection that is gray.

Step 2 Verify the alarm is valid, then perform the following steps for both DWDM nodes connected to the span identified in [Step 1](#).

- a. Double-click the card directly connected to the span (either the OPT-BST or the OSC-CSM).

- b. Click the Alarms tab and verify that a LOS condition is present on the LINE-RX port. If the alarm is correctly reported, move to [Step 3](#). If not, close the CTC application, delete the CTC cache and reopen the CTC connection.
- c. Click the **Synchronize** button on the bottom left of the window.



Note If the “gray” condition of the span persists, log into the Technical Support website at <http://www.cisco.com/techsupport> for more information or call Cisco TAC (1-800-553-2447) to report a service-affecting problem.

Step 3 If the network ALS setting on the DWDM nodes that you are troubleshooting is Auto Restart, continue with [Step 4](#); if the network ALS setting is DISABLE, go to [Step 5](#).



Note The network ALS setting is a function of the ALS mode configured on the appropriate cards in the system (OPT-BST, OPT-BST-E, OPT-BST-L, OPT-AMP-L, OPT-AMP-C, OPT-AMP-17C, OSC-CSM, and OSCM).

- Step 4** Isolate the fiber affected by the fiber cut. For the two fibers belonging to the span, identify the fiber belonging to the west-to-east (W–E) line direction:
- a. Go into the upstream node and identify the OSCM or OSC-CSM card managing the OSC termination referring to the faulty span.
 - b. Double-click the card, then click the **Maintenance Panel** tab.
 - c. Force the OSC-TX laser to be active by setting the ALS Mode to **DISABLE**.
 - d. Go into the downstream node and verify if OSC power is being received.
 - If a pair of OPT-BST + OSCM cards terminate the OSC connection, click the **Provisioning > Optical Line > Parameters** tabs, then verify that there is power for OSC-TX (Port 4).
 - If an OSC-CSM terminates the OSC connection, click the **Provisioning > Optical Line > Parameters** tabs, then verify that there is power for OSC-RX (Port 6).
 - e. If no power is detected and the LOS (OC-3) alarm persists, go to [Step 5](#); otherwise, the fiber under test is good. In this case, go to [Step f](#) to check the other fiber.
 - f. Repeat Steps [a](#) to [d](#) for the other fiber to verify that it is at fault.

Step 5 Repair the identified broken fiber to restore the internode link.



Warning

Invisible laser radiation may be emitted from the end of the unterminated fiber cable or connector. Do not view directly with optical instruments. Viewing the laser output with certain optical instruments (for example, eye loupes, magnifiers, and microscopes) within a distance of 100 mm may pose an eye hazard. Statement 1056



Note Before disconnecting any optical amplifier card fiber for troubleshooting, ensure that the optical amplifier card is unplugged.

1.12.2 System Restart after a Fiber Cut

When the network ALS setting is Auto Restart, the system automatically restarts after a fiber cut occurs. MSTP system restart after a fiber cut is a fully automatic process regulated by a chronological sequence of steps including the OSC link built-in amplifiers restart and amplifier power control (APC) regulation.

The successful completion of system restart is strictly related to possible changes of the insertion loss value of the repaired span. A change in insertion loss is dependent on many factors, including the process of physically repairing the fiber, a change in fiber length after repair, and so on.

Four different scenarios related to span loss are presented in this section:

1. Span loss increased:
 - Span loss change > 5 dBm
 - OSC power value on the receiver < -42 dBm
2. Span loss increased:
 - Span loss change > 5 dBm
 - OSC power value on the receiver > -42 dBm
3. Span loss increased: 3 dBm $<$ span loss change < 5 dBm
4. Span loss increased: span loss change < 3 dBm



Note

It is also possible that span loss decreased, but this is unlikely. This condition does not prevent the MSTP system automatic restart process, but can lead (potentially) to issues downstream of the repaired span, for example, a Power Overload condition on the OSC receiver or on the Trunk-RX port of a TXP or MXP card.

These conditions are identified by specific alarms (see the “HI-RX-POWER” section of [Chapter 2, “Alarm Troubleshooting”](#) of the *DWDM Alarm and Troubleshooting Guide*).

The symptoms of the possible span loss scenarios (except for span loss decrease) are described in the following paragraphs. Refer to the linear network in [Figure 1-21 on page 1-62](#) during the discussion of the scenarios.

The basic assumption is that the network ALS feature (for feature details, refer to the “Network Optical Safety—Automatic Laser Shutdown” section in the *Cisco ONS 15454 DWDM Reference Manual*) is active (ALS Mode = Auto Restart on the OPT-BST, OPT-AMP-x-C, [+ OSCM] and OSC-CSM). Given this assumption, the starting condition is as shown in [Figure 1-22 on page 1-63](#).

The system behavior when the network ALS Mode is DISABLE is a subcase that requires a manual restart after repairing a single fiber in only one line direction.



Note

The network ALS feature is a function of the ALS Mode settings of the OPT-BST, OPT-BST-E, OPT-BST-L, OPT-AMP-L, OPT-AMP-x-C, OPT-RAMP-C, OSCM, and OSC-CSM cards. For the network ALS Mode to be disabled, each of these cards must have its ALS Mode set to DISABLE.

1.12.2.1 Scenario 1: Span Loss Change > 5 dBm and OSC Power Value on the Receiver < -42 dBm

In network view, both of the lines representing the span remain gray as long as the status of the OCHNC circuits relating to the repaired span remain in Partial state.

In node view (single-shelf mode) or shelf view (multishelf mode), the alarm panels of the two nodes (ROADM and OLA in this example) show the LOS (OTS or AOTS) condition on the LINE-RX port of the OPT-BST, OPT-AMP-x-C, or OSC-CSM.

An EOC condition is always present on both nodes because the OSC optical link is down due to an incoming power level lower than the optical sensitivity limit (−42 dBm). The system condition remains unchanged as illustrated in [Figure 1-22](#).

Every 100 seconds, the ALS protocol turns up the OSC TX laser in a pulse mode (pulse duration = 2 seconds), but the excessive loss on the span prevents the OSC link from synchronizing, and the MSTP system remains unoperational.

**Note**

During the attempt to restart, a valid power value is reported by the OSC transmit card (in the example, the OSC-CSM in the OLA node), but on the OSC receive card (the OSCM in the ROADM node), the alarm condition persists.

Corrective Action for Scenario 1

- Step 1** Follow these steps to verify the alarms for both DWDM nodes that are connected to the repaired span:
- Double-click the card directly connected to the span (either the OPT-BST, OPT-AMP-x-C, or OSC-CSM).
 - Click the **Alarms** tab.
 - Verify that a LOS condition is present on the LINE-RX port.
 - Click the **Synchronize** button on the bottom left of the window.
 - If the alarm is correctly reported, move to [Step 2](#). If not, close the CTC application and delete the CTC cache. Then reopen the CTC connection, and repeat [Step 1](#).

**Note**

If the gray color persists on the span, log into the Technical Support Website at <http://www.cisco.com/techsupport> for more information or call Cisco TAC (1-800-553-2447) in order to report a service-affecting problem.

- Step 2** Isolate the fiber affected by the excessive insertion loss. For the two fibers belonging to the span, identify the one for the W–E line direction.
- Go into the upstream node and identify the OSCM or OSC-CSM card that manages the OSC termination for the faulty span.
 - Double-click the card, then click the **Maintenance** tab.
 - Force the OSC-TX laser active by setting ALS Mode to **DISABLE**.
 - Go into the downstream node and verify the OSC Power level received.
 - If a pair of OPT-BST or OPT-AMP-x-C + OSCM cards terminate the OSC connection, click the **Provisioning > Optical Line > Parameters** tabs, then verify that there is power for OSC-TX (Port 4).
 - If an OSC-CSM terminates the OSC connection, click the **Provisioning > Optical Line > Parameters** tabs, then verify that there is power for OSC-RX (Port 6).
 - If no power is detected and the LOS (OC-3) alarm persists, the faulty fiber has been identified, so go to [Step 3](#).

- e. If a power value greater than -42 dBm is detected, the fiber under test has been properly repaired. However, it is recommended that you check the new fiber Insertion Loss value.
 - In node view (single-shelf mode) or shelf view (multishelf mode), click the **Maintenance > DWDM > WDM Span Check** tabs.
 - Retrieve the new value of fiber Insertion Loss of the repaired span.



Note The new value of the fiber Insertion Loss of this fiber after restoration must be less than 5 dB higher than the previous Insertion Loss value. If possible, try to recover the original value by making a better fiber splice. If this is not possible, use the new value (must be less than 5 dB higher than the previous value) and rerun Cisco TransportPlanner to revalidate the new condition.

- Step 3** For the two fibers belonging to the repaired span, identify one for the east to west (E–W) line direction.
- Step 4** Repeat the procedure starting at [Step 2](#) for the E–W direction.
- Step 5** Clean the LINE-RX and LINE-TX connectors for the failing fiber that was identified in the previous steps.
- Step 6** If the problem persists, continue with [Step 7](#). Otherwise, the corrective action is finished.
- Step 7** Repair the failing fiber again until the expected OSC link is reestablished.

**Warning**

Invisible laser radiation may be emitted from the end of the unterminated fiber cable or connector. Do not view directly with optical instruments. Viewing the laser output with certain optical instruments (for example, eye loupes, magnifiers, and microscopes) within a distance of 100 mm may pose an eye hazard. Statement 1056



Note Before disconnecting any optical amplifier card fiber for troubleshooting, ensure that the optical amplifier card is unplugged.



Note If the OSC link cannot be reestablished (either by splicing or replacing the fiber), and the new value of Span Loss cannot be modified, log into the Technical Support Website at <http://www.cisco.com/techsupport> for more information or call Cisco TAC (1 800 553-2447) in order to report a service-affecting problem.

1.12.2.2 Scenario 2: Span Loss Change > 5 dBm and OSC Power Value on the Receiver > -42 dBm

In network view, both of the lines representing the span change to green; however, the status of the OCHNC circuits relating to the repaired span remains Partial, instead of Complete (due to the fiber cut).

This change is due to the fact the physical optical power value received by the OSC transceiver is above the sensitivity limit (-42 dBm) and consequently, the OSC optical link can be rebuilt, allowing the restoration of the Section DCC (SDCC) or multiplex section DCC (MS-DCC). The network view for this condition is shown in [Figure 1-28](#).

Figure 1-28 Network View for Span Loss Change > 5 dBm and OSC Power Value at Receiver > -42 dBm

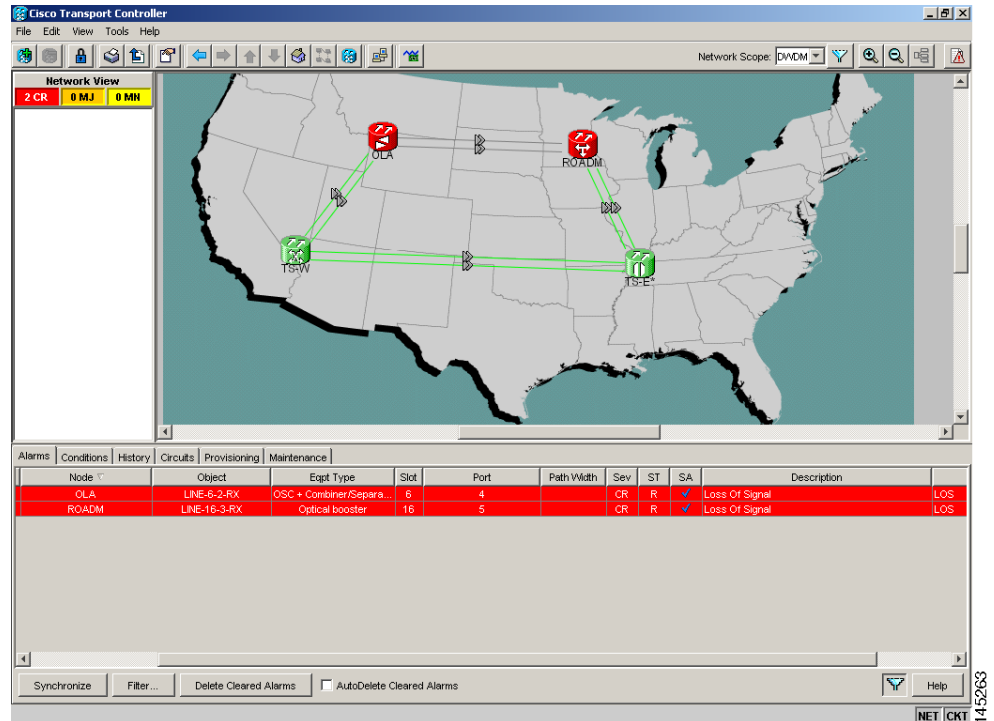

In node view (single-shelf mode) or shelf view (multishelf mode), the EOC condition is cleared, but the alarm panels of the two nodes (ROADM and OLA in the example) continue to show LOS (OTS or AOTS) on the LINE-RX port of the OPT-BST, OPT-AMP-x-C, or OSC-CSM.

The network ALS protocol keeps the OCHNC traffic down along the span because the new losses of the restored span can potentially affect the optical validation of the network design done by Cisco TransportPlanner.

Corrective Action for Scenario 2

- Step 1** Verify the validity of the alarm.
- Step 2** For both DWDM nodes connected to the repaired span:
- Double-click the card directly connected with the span (either the OPT-BST, OPT-AMP-x-C, or OSC-CSM).
 - Click **Alarms**.
 - Click the **Synchronize** button on the bottom left of the window.
 - Verify that a LOS condition is present on the LINE-RX port.
 - If the alarm is correctly reported, move to [Step 3](#). If not, close the CTC application, delete the CTC cache, and open the CTC connection again. Then, go back to [Step 1](#).

**Note**

If the “gray condition” of the span persists, log into the Technical Support Website at <http://www.cisco.com/techsupport> for more information or call Cisco TAC (1 800 553-2447) in order to report a service-affecting problem.

Step 3 Measure the new Span Loss value after fixing the fiber.

- a. In the node view (single-shelf mode) or shelf view (multishelf mode) of both nodes for the span, click the **Maintenance > DWDM > WDM Span Check** tabs.
- b. Click **Retrieve Span Loss Values** to retrieve the latest loss data.

**Note**

The two values retrieved at each node level (west side and east side) refer to the two fibers coming into the node from the adjacent nodes, so they apply to different spans. To complete the measurement in [Step 3](#), the appropriate values must be taken into account.

Step 4 Compare the span measurements of [Step 3](#) with the span losses values used during the network design with Cisco TransportPlanner.

Step 5 For the two fibers belonging to the repaired span, identify the fiber for the W–E line direction and calculate the insertion loss variation. If the span loss change is greater than 3 dBm, continue with [Step 6](#). If not, go to [Step 9](#).

Step 6 Clean the LINE-RX and LINE-TX connectors on the DWDM cards managing the fiber of the repaired span. If the problem persists, continue with [Step 7](#).

Step 7 If the alarm condition is still reported, it is recommended that the fiber be repaired again to reestablish the expected span loss value. If this is not possible and the new value of span loss cannot be modified, go to [Step 8](#) to fix the system faulty condition.

**Warning**

Invisible laser radiation may be emitted from the end of the unterminated fiber cable or connector. Do not view directly with optical instruments. Viewing the laser output with certain optical instruments (for example, eye loupes, magnifiers, and microscopes) within a distance of 100 mm may pose an eye hazard. Statement 1056

**Note**

Before disconnecting any optical amplifier card fiber for troubleshooting, ensure that the optical amplifier card is unplugged.

Step 8 Follow the signal flow into the network starting from the repaired fiber:

- a. In the downstream node, identify the OPT-BST, OPT-AMP-x-C, or OSC-CSM card that manages OSC and CHS detection.
- b. In card view, click the **Provisioning > Optical Line > Optic Thresholds** tabs.
- c. Click the **Alarms** radio button, then click **Refresh**.
- d. Decrease the current OSC and CHS Fail Low thresholds by the same amount of the span loss change calculated in [Step 5](#).

If an OPT-BST or OPT-AMP-x-C is present:

- CHS Fail Low threshold refers to Port 2.
- OSC Fail Low threshold refers to Port 4.

If an OSC-CSM is present:

- CHS Fail Low threshold refers to Port 3.
- OSC Fail Low threshold refers to Port 6.

- Step 9** For the two fibers belonging to the repaired span, identify the fiber for the east to west (E–W) line direction.
- Step 10** Repeat the procedure from [Step 5](#) to [Step 8](#) for the E–W direction.
- Step 11** If the LOS alarm has cleared, the system has restarted properly. However, because a significantly different span loss value is now present, we highly recommend that you complete the following steps:
- a. Go back to the Cisco TransportPlanner tool and open the network design configuration file.
 - b. Select **Installation Mode** to freeze the node layout and amplifier positioning.
 - c. Change the span value, inserting the new insertion loss that was measured in [Step 3](#).
 - d. Run the Cisco TransportPlanner algorithm to validate the new design.
 - e. If the optical result indications (power, optical signal-to-noise ratio [OSNR], chromatic dispersion [CD], and so on) are all green, the repair procedure is complete. If not, log into the Technical Support Website at <http://www.cisco.com/techsupport> for more information or call Cisco TAC (1 800 553-2447) and report a service-affecting problem.

If the LOS alarm is still present, continue with [Step 12](#).

- Step 12** Go back to the card where the LOS alarm is active, and set the optic thresholds (see [Step 8b](#)) to the lowest value allowed.

If an OPT-BST or OPT-AMP-x-C is present:

- CHS Fail Low threshold must to be set to –30 dBm.
- OSC Fail Low threshold must to be set to –42 dBm.

If an OSC-CSM is present:

- CHS Fail Low threshold must to be set to –30 dBm.
- OSC Fail Low threshold must to be set to –40 dBm.

**Note**

If the LOS alarm is still present, log into the Technical Support Website at <http://www.cisco.com/techsupport> for more information or call Cisco TAC (1 800 553-2447) in order to report a service-affecting problem.

- Step 13** If the LOS alarm is has cleared, the system has restarted properly, but because a Span Loss value significantly different from the design is now present, we highly recommend that you repeat the steps described in [Step 11](#).

1.12.2.3 Scenario 3: 3 dBm < Span Loss Change < 5 dBm

In network view, both of the lines representing the span change to green after the rebuild of the OSC optical link and consequent restoration of the SDCC or MS-DCC. The EOC condition and the LOS alarms are cleared.

The network ALS protocol successfully restarts the amplifiers, which enables the OCHNC traffic restoration along the span.

The reactivation of the OCHNC circuits relating to the repaired span (the status changes from Partial to Complete) can lead to several final conditions that depend on the network topology and node layout.

The rebuilding of circuits automatically triggers the APC check mechanism (for details, refer to the “Network Reference” chapter of the *Cisco ONS 15454 DWDM Reference Manual*). The APC check mechanism impacts the optical gain of the amplifiers (primarily the OPT-PRE card) and the VOA express attenuation for the optical add/drop multiplexing (OADM) cards. The APC application acts on the appropriate cards downstream of the repaired span (for each line direction), and attempts to compensate for the introduction of excess loss.

Because the loss increase exceeds the maximum variation (± 3 dBm) for which APC is allowed to compensate, an APC-CORRECTION-SKIPPED condition is raised by the first node along the flow detecting the event. The condition panel of the impacted node (the ROADM, in this example) reports the APC-CORRECTION-SKIPPED condition and indicates the port or card to which it applies.

To correct Scenario 3:

-
- Step 1** Verify the alarm validity.
- Step 2** For both DWDM nodes connected to the repaired span:
- a. Double-click the card reporting the issue.
 - b. Click **Conditions**.
 - c. Click **Retrieve** and verify that an APC-CORRECTION-SKIPPED condition is present on an aggregate port.
 - d. If the alarm is correctly reported, go to [Step 3](#). If not, close the CTC application, delete the CTC cache, and open the CTC connection again. Then, go to [Step 1](#).



Note If the discrepancy persists, log into the Technical Support Website at <http://www.cisco.com/techsupport> for more information or call Cisco TAC (1 800 553-2447) in order to report a service-affecting problem.

- Step 3** Measure the new Span Loss value after the fiber has been repaired.
- a. In the node view (single-shelf mode) or shelf view (multishelf mode) of both nodes of the span, click the **Maintenance > DWDM > WDM Span Check** tabs.
 - b. Click **Retrieve Span Loss Values** to retrieve the latest loss data.



Note The two values retrieved at each node level (west side and east side) refer to the two fibers coming into the node from the adjacent nodes, so they apply to different spans. To complete the measurement in [Step 4](#), the appropriate values must be taken into account.

- Step 4** Compare the Span Measurements of the previous step with the Span Losses values used during the network design with Cisco TransportPlanner.
- Step 5** For the two fibers belonging to the repaired span, identify the one for the W–E line direction. If the Span Loss Change is greater than 3 dB, continue with [Step 6](#). If not, go to [Step 9](#).
- Step 6** Clean the LINE-RX and LINE-TX connectors of the DWDM cards that manage the fiber of the repaired span. If the problem persists, continue with [Step 7](#). Otherwise, you are finished with the corrective action.

- Step 7** If the alarm condition is still reported, we recommend that you again repair the fiber to reestablish the expected span loss value. If this is not possible and the new value of Span Loss cannot be modified, move to [Step 8](#) to fix the system faulty condition.

**Warning**

Invisible laser radiation may be emitted from the end of the unterminated fiber cable or connector. Do not view directly with optical instruments. Viewing the laser output with certain optical instruments (for example, eye loupes, magnifiers, and microscopes) within a distance of 100 mm may pose an eye hazard. Statement 1056

**Note**

Before disconnecting any optical amplifier card fiber for troubleshooting, ensure that the optical amplifier card is unplugged.

- Step 8** Follow the signal flow into the network starting from the repaired fiber.
- In the first downstream node of the restored span (W–E), check whether a DWDM card reports the APC-CORRECTION-SKIPPED condition on a port applying to the W–E direction (see [Step 2](#) for how to do this).
 - If the answer is yes, retrieve the following values according to the card type.
 - For pre- or booster amplifier cards, click the **Provisioning > Optical Ampli. Line > Gain Setpoint** tabs.
 - For AD-xC-xx.x or AD-xB-xx.x cards, click the **Provisioning > Optical Line > VOA Attenuation Reference** tabs.
 - Go to [Step 8f](#).
 - If the answer is no, go to [Step 8d](#).
 - Move along the downstream nodes until a card with the APC-CORRECTION-SKIPPED condition for a W–E port is detected.
 - From that card, retrieve parameters according to [Step 8b](#).
 - In the first downstream node of the restored span, go to the Circuits tab and identify all the OCHNC circuits passing through the repaired span.
 - Edit all the OCHNC circuits identified in [Step 8f](#):
 - Click the **Tools > Circuits > Set Circuit State** tabs.
 - Change the Target Circuit Admin. State to **OOS,DSBLD** (or **Locked, disabled**) and click **Apply**.
 - Go to the DWDM card for which the Gain or VOA Attenuation values were retrieved (the card can be either the one in substep [Step 8b](#) or [Step 8e](#)) and verify that the administrative state of the alarmed port is now OOS (locked).
 - If the alarmed port is not OOS (locked), go to the card view, click **Circuits**, and identify the remaining OCHNC circuits that are still active. Put the circuits in **OOS,DSBLD** (or **Locked, disabled**) state in order to reach the OOS (locked) administrative state on the alarmed port.
 - Wait for three minutes, then switch the administrative state of only one of the circuits selected in [Step 8f](#) and [Step 8i](#) back to **IS (Unlocked)**.
 - After the network completes the restart phase, go to the formerly alarmed card and verify that the APC-CORRECTION-SKIPPED condition has cleared and a new Gain Setpoint or VOA Attenuation Reference (compare with [Step 8a](#)) has been provisioned.



Note The total variation of the above parameter setpoint must be within approximately +/- 1 dBm of the Span Loss Change measured in [Step 3](#).

- I. If the APC-CORRECTION-SKIPPED condition has cleared and the system has restarted properly, we highly recommend that you complete the following procedure due to the fact that a Span Loss value that is significantly different than the design is now present.
 - Go back to the Cisco TransportPlanner tool and open the network design configuration file.
 - Select **Installation Mode** to freeze the node layout and amplifier positioning.
 - Change the span value, inserting the new Insertion Loss measured in [Step 3](#).
 - Run the Cisco TransportPlanner algorithm to validate the new design.
 - If the optical result indications (power, OSNR, CD, and so on) are all green, the repair procedure is complete. If not, log into the Technical Support Website at <http://www.cisco.com/techsupport> for more information or call Cisco TAC (1 800 553-2447) in order to report a service-affecting problem.



Note If the APC condition persists, log into the Technical Support Website at <http://www.cisco.com/techsupport> for more information or call Cisco TAC (1 800 553-2447) in order to report a service-affecting problem.

- Step 9** For the two fibers belonging to the repaired span, identify the fiber for to the east to west (E–W) line direction.
- Step 10** Repeat the procedures from [Step 6](#) to [Step 8](#) for the E–W direction.
-

1.12.2.4 Scenario 4: Span Loss Change < 3 dB

In network view, both the lines that represent the span turn green after the rebuilding of the OSC optical link and consequent restoration of the SDCC or MS-DCC. The EOC condition and LOS alarms are cleared.

The network ALS protocol successfully completes the amplifier restart to enable OCHNC traffic restoration along the span.

The rebuilding of circuits automatically triggers the APC check mechanism (for details, refer to the “Network Reference” chapter of the *Cisco ONS 15454 DWDM Reference Manual*). The APC check mechanism affects the optical gain of the amplifiers (primarily the OPT-PRE) and the VOA express attenuation for the OADM cards. The APC application acts on the “suitable” cards downstream of the repaired span (for each line direction), and attempts to compensate for the introduction of excess loss.

The APC operation is successfully completed if enough margin during the Cisco TransportPlanner network design phase has been taken into account. If not, the adjustment done by the APC application overcomes the range setting for a specific optical parameter in the first appropriate card along the flow and an APC-OUT-OF-RANGE condition is raised. The condition panel of the impacted node (the ROADM in the example) reports the APC-OUT-OF-RANGE condition and indicates the port or card to which it applies.

To correct Scenario 4:

Step 1 Verify the alarm validity.

Step 2 For both DWDM nodes on the repaired span:

- a. Double-click the card reporting the issue.
- b. Click **Conditions**.
- c. Click **Retrieve** and verify that an APC-OUT-OF-RANGE condition is present on an aggregate port.
- d. If the alarm is correctly reported, go to [Step 3](#). If not, close the CTC application, delete the CTC cache, and open the CTC connection again. Then, go to [Step 1](#).



Note If the discrepancy persists, log into the Technical Support Website at <http://www.cisco.com/techsupport> for more information or call Cisco TAC (1 800 553-2447) in order to report a service-affecting problem.

Step 3 Measure the new Span Loss value after the fiber is repaired.

- a. In the node view (single-shelf mode) or shelf view (multishelf mode) of both nodes for to the span, click the **Maintenance > DWDM > WDM Span Check** tabs.
- b. Click **Retrieve Span Loss Values** to retrieve the latest loss data.



Note The two values retrieved at each node level (west side and east side) refer to the two fibers coming into the node from the adjacent nodes, so they apply to different spans. To complete the measurement in [Step 4](#), the appropriate values must be taken into account.

Step 4 Compare the Span Measurements done in [Step 3](#) with the Span Losses values used during the network design with Cisco TransportPlanner.

Step 5 For the two fibers belonging to the repaired span, identify the one for the W–E line direction.

- If the Span Loss Change is greater than 1 dBm, continue with [Step 6](#).
- If the Span Loss Change is 1 dBm or less, move to [Step 9](#).

Step 6 Clean the LINE-RX and LINE-TX connectors of the DWDM cards that manage the fiber of the repaired span.

Step 7 If the problem persists, continue with the next step. If not, you have finished the corrective action.

Step 8 If the Span Loss Change is greater than 1 dBm and the APC-OUT-OF-RANGE condition still exists, it is mandatory to again repair the fibers to reestablish the expected span loss value.



Warning

Invisible laser radiation may be emitted from the end of the unterminated fiber cable or connector. Do not view directly with optical instruments. Viewing the laser output with certain optical instruments (for example, eye loupes, magnifiers, and microscopes) within a distance of 100 mm may pose an eye hazard. Statement 1056



Note Before disconnecting any optical amplifier card fiber for troubleshooting, ensure that the optical amplifier card is unplugged.



Note If this is not possible and the new value of Span Loss cannot be modified, log into the Technical Support Website at <http://www.cisco.com/techsupport> for more information or call Cisco TAC (1 800 553-2447) in order to report a service-affecting problem

- Step 9** For the two fibers belonging to the repaired span, identify the fiber for the east to west (E–W) line direction.
- Step 10** Repeat the procedure from [Step 6](#) to [Step 8](#) for the E–W direction.
-

1.12.3 OCHNC Circuits Creation Failure

OCHNC circuit creation is managed by the Cisco Wavelength Path Provisioning (WPP) network application. The WPP application helps prevent errors during new circuit activation (if the wavelength is already allocated in the path between source and destination) and also guarantees an appropriate time interval between one circuit activation and the next to enable proper amplifier gain regulation by APC.

WPP uses the network topology information carried by the OSC link among different nodes to identify the routing path of the optical wavelength (OCHNC circuits) from the source node to the destination node. WPP also enables the card ports of the OCHNC circuits by changing the administrative state from the default (OOS or Locked) state to the final (IS or Unlocked) state.

1.12.3.1 Prerequisites for Successful OCHNC Circuit Creation

The prerequisite conditions for successfully completed circuit creation are:

1. Internode: OSC link active among all DWDM nodes involved
2. Internode: APC enabled (or alternatively manually disabled by the user)
3. Intranode: Logical connections among cards created and provisioned on every node of the network (ANS completed)



Note For more information about these operations, refer to the “NTP-G183 Diagnose and Fix OCHNC and OCH Trail Circuits” section in “Create Optical Channel Circuits and Provisionable Patchcords” chapter in the *Cisco ONS 15454 DWDM Procedure Guide*.

OCHNC circuit creation is successfully completed when the CTC circuit table reports the situation shown in [Figure 1-29](#).

- The Circuit Status has turned to DISCOVERED.
- The # of spans field shows the correct number of hops among different nodes that the OCHNC circuit passes through to reach the final destination.
- Circuit State reports IS (or unlocked).

Figure 1-29 OCHNC Circuit Successfully Completed

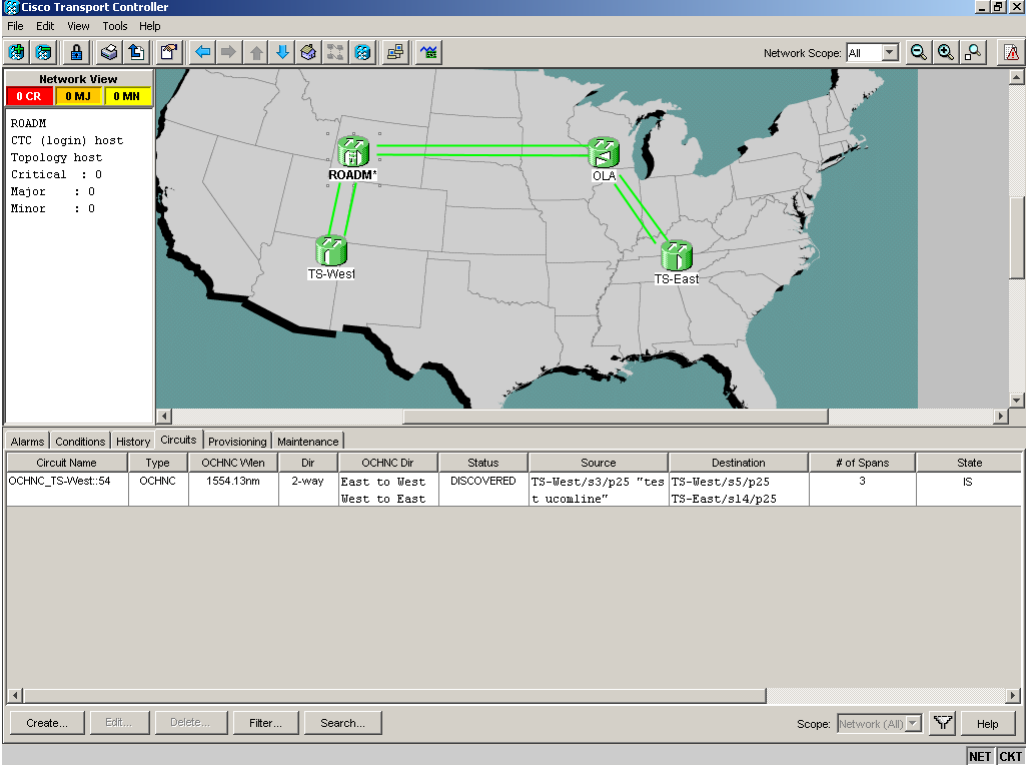

The screenshot shows the Cisco Transport Controller (CTC) interface. The top left pane displays network statistics: 0 CR, 0 MJ, and 0 MN. The main pane shows a map of the United States with four nodes: ROADM, OLA, TS-West, and TS-East. Green lines connect ROADM to OLA, and both ROADM and OLA to TS-West and TS-East. The bottom pane shows a table of circuits.

Circuit Name	Type	OCHNC Wlen	Dir	OCHNC Dir	Status	Source	Destination	# of Spans	State
OCHNC_TS-West:54	OCHNC	1554.13nm	2-way	East to West West to East	DISCOVERED	TS-West/s3/p25 "test uonline"	TS-West/s5/p25 TS-East/s14/p25	3	IS

1.12.3.2 Conditions for OCHNC Circuit Creation Failure

If the OCHNC circuit creation fails, you will see one of the following conditions:

- If the WPP wizard cannot complete the circuit creation procedure, CTC displays the error message shown in Figure 1-30. In the message, click **Details** to see the partial connections that WPP can set up. Start troubleshooting the problem in the first node that is unreachable along the path.

Figure 1-30 Partial Circuit

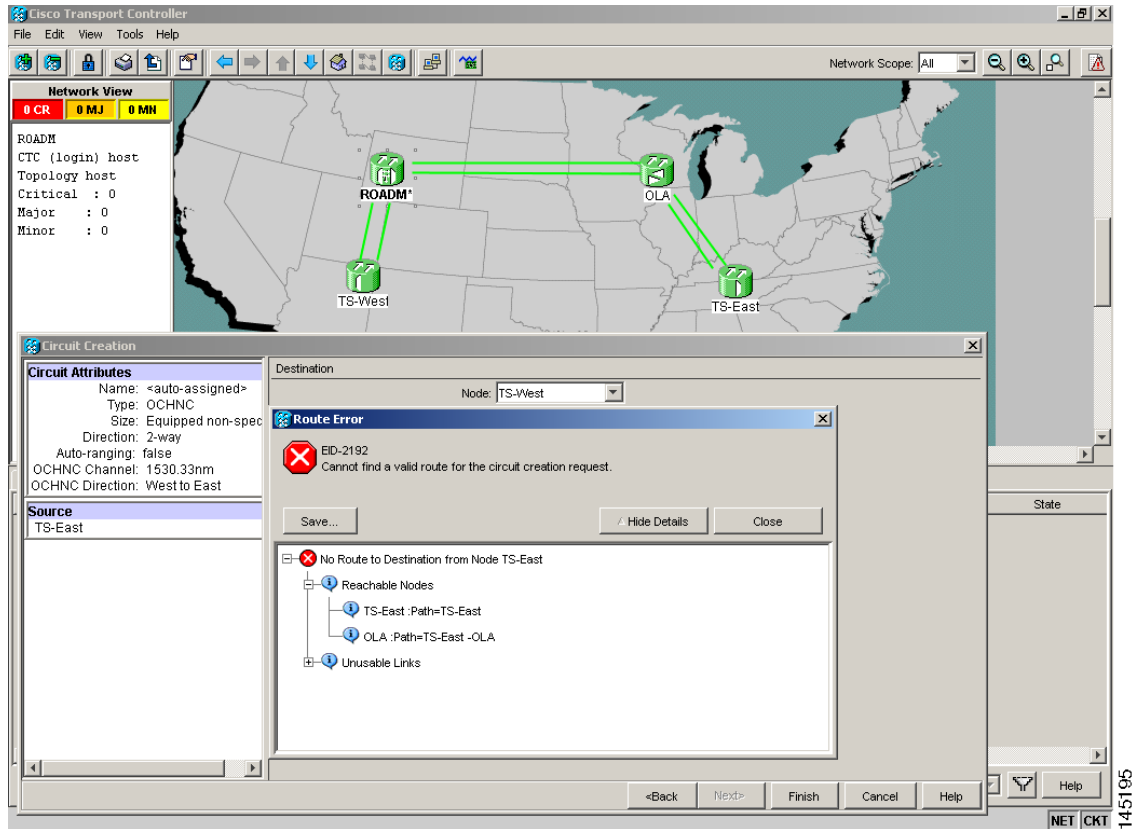

- The circuit is successfully created and reported under the Circuits tab, the Status field turns to DISCOVERED, but the Circuit State is OOS (locked). The condition is shown in Figure 1-31.

Figure 1-31 Circuit Discovered, State OSS

The screenshot displays the Cisco Transport Controller interface. The top section shows a network map with four nodes: ROADM (green), OLA (green), TS-West (red), and TS-East (red). The bottom section shows a table with the following data:

Circuit Name	Type	OCHNC/Men	Dir	OCHNC Dir	Status	Source	Destination	# of Spans	State
OCHNC_TS-West:57	OCHNC	1554.13nm	2-way	East to West West to East	DISCOVERED	TS-West/s3/p25 "tes t ucomline"	TS-East/s14/p25 TS-West/s5/p25	3	OOS

- The OCHNC circuit is shown under the Circuits tab, but the Status field reports PARTIAL. This applies to a circuit successfully built-up when the network falls into scenarios a. or b (OSC link fail or APC disabled), described below.

The root cause identification for the preceding conditions are found in the prerequisite conditions described in [1.12.3.1 Prerequisites for Successful OCHNC Circuit Creation](#).

1.12.3.3 Scenarios for OCHNC Circuit Creation Failure

The most common scenarios for failure to create an OCHNC circuit are:

1. One (or more) of the Span OSC links involving the OCHNC circuit has not been properly established. The WPP application prevents the creation of any circuit passing through the failing span. Prerequisite condition 1. of [1.12.3.1 Prerequisites for Successful OCHNC Circuit Creation](#) has not been met.
 - a. The APC application is internally disabled due to the presence of a Critical alarm somewhere in the network. As a consequence, no reliable information about the number of active channels can be shared among the nodes and the creation of any further OCHNC circuit is prevented until the faulty condition is fixed. Prerequisite condition 2. of [1.12.3.1 Prerequisites for Successful OCHNC Circuit Creation](#) has not been met.
 - b. One (or more) of the intranode connections between two DWDM cards associated with the circuit have not been properly created. Prerequisite condition 3. of [1.12.3.1 Prerequisites for Successful OCHNC Circuit Creation](#) has not been met.

- c. One (or more) of the intranode connections between two DWDM cards associated with the circuit have not been properly provisioned. This happens when ANS application has not run in one of the involved nodes or at least one port status after the ANS run has not been successfully configured (Fail-Out of Range alarm on the ANS panel). Prerequisite condition 3. of [1.12.3.1 Prerequisites for Successful OCHNC Circuit Creation](#) has not been met.

To troubleshoot and eventually fix issues related to the faulty OCHNC circuit creation shown in [Figure 1-30 on page 1-82](#), the following procedure must be performed.

Step 1 Verify OSC connectivity:

- a. Go to network view and identify the MSTP nodes to which the OCHNC circuit applies.
- b. Verify that all the OSC links connecting the MSTP nodes along the circuit path, from the source node to the destination node, are active (green line).



Note Bidirectional circuits have two possible nodes, depending on the line direction being considered.

Complete one of the following actions depending on OSC connectivity:

- If the OSC link is down, focus on the affected span and troubleshoot the issue (see [1.12.2 System Restart after a Fiber Cut, page 1-70](#)).



Note If necessary, log into the Technical Support Website at <http://www.cisco.com/techsupport> for more information or call Cisco TAC (1 800 553-2447) in order to report a service-affecting problem.

- If the OSC link is not down, continue with [Step 2](#).

Step 2 Verify APC status:

- a. Go to node view (single-shelf mode) or shelf view (multishelf mode) on the MSTP node that is the source node for the circuit.
- b. In the General Info box on the left, check the APC state (last row).
 - If the APC state is DISABLE - INTERNAL, complete the appropriate troubleshooting procedure from [Chapter 2, “Alarm Troubleshooting”](#).



Note If necessary, log into the Technical Support Website at <http://www.cisco.com/techsupport> for more information or call Cisco TAC (1 800 553-2447) in order to report a service-affecting problem.

- If the APC state is not DISABLE - INTERNAL, continue with [Step 3](#).

Step 3 Verify that the intranode connections have been built in:

- a. Go to the node view (single-shelf mode) or multishelf view (multishelf mode) on the MSTP node that is the source node for the circuit.
- b. Click the **Provisioning > WDM-ANS > Connections** tabs.

Step 4 Verify that all node connections have been created and that their state is Connected.

**Tip**

To quickly verify the connections, click the **Calculate Connection** button and check to see if any new connections come up.

If some connections are missing, perform the proper procedure according to “Turn Up a Node” in the *Cisco ONS 15454 DWDM Procedure Guide*.

- Step 5** If necessary, log into the Technical Support Website at <http://www.cisco.com/techsupport> for more information or call Cisco TAC (1 800 553-2447) in order to report a service-affecting problem.

1.13 Node Level (Intranode) Problems

Troubleshooting for node-level optical channel (OCH) VOA start-up failure as well as internal VOA control loop problems in the amplifier cards (OPT-BST , OPT-BST-L, OPT-PRE, OPT-AMP-17-C, OPT-AMP-C, OPT-AMP-L, and OPT-BST-E); demultiplexer cards (32-DMX, 32-DMX-L, 40-DMX-C, and 40-DMX-CE) having a single variable optical attenuator (VOA); and optical add/drop multiplexer cards (AD-1C-xx.x, AD-2C-xx.x, AD-4C-xx.x, AD-1B-xx.x, and AD-4B-xx.x) that occur due to counter-propagating light are discussed in this section.

A dedicated VOA regulates the optical power for every single channel (single wavelength) inserted in the MSTP system through a WSS, 32MUX-O, or AD-xC-xx.x card.

The final state for the VOAs is the power control working mode. In this mode, the attenuation that the VOA introduces is automatically set based on the feedback provided from a dedicated photodiode, so that a specific power setpoint value is reached and maintained.

1.13.1 VOA Startup Phases

The final VOA condition is achieved through a startup procedure divided into the four sequential phases shown in [Figure 1-32](#).

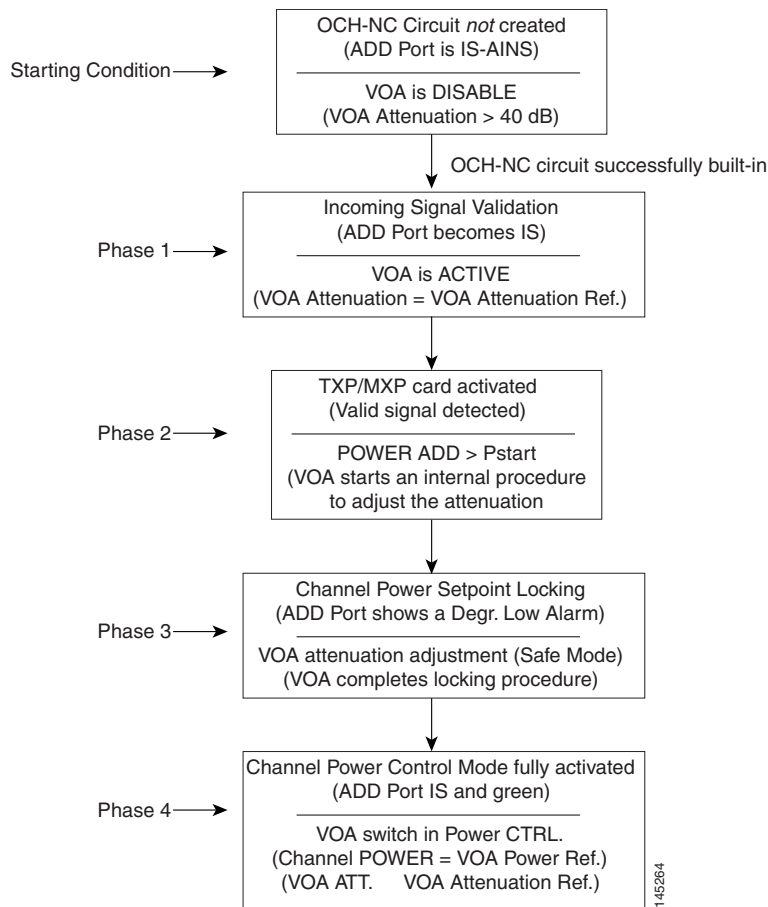
Figure 1-32 VOA Startup Procedure

Until the VOA has completed all the phases shown in [Figure 1-32](#), the power control mode is not fully activated.

1.13.1.1 Phase 1: Incoming Signal Validation

The Incoming Signal Validation phase checks to see that the optical interface connection is valid and that the optical power level is appropriate.

Cisco TransportPlanner calculates the VOA Attenuation Reference value to allow only supported MSTP interfaces to overcome the power start-up (Pstart-up) acceptance level. (Refer to the “Network Reference” chapter of the *Cisco ONS 15454 DWDM Reference Manual*.)

If the interface that is connected has a power value outside the allowed range, the Phase 1 check prevents OCHNC turn-up.

1.13.1.2 Phase 2: Valid Signal Detected

If Phase 1 indicates that the signal is valid, an automatic iterative attenuation adjustment on the VOA takes place to reach a power target on the photodiode downstream of the VOA.

**Note**

The power setpoint is generated by Cisco TransportPlanner on a case-by-case basis. During the ANS run, the power target is provisioned on the VOA.

1.13.1.3 Phase 3: Channel Power Setpoint Locking

In Phase 3, the VOA is kept in a transient standby condition when a steady power value close enough to the final power setpoint has been reached (nominally 3 dBm lower).

The duration of the transient standby condition is three seconds (by default) and allows safe management of optical interfaces that have different signal rise time values or are undergoing a pulse startup procedure compliant with the ITU-T G664 recommendation.

1.13.1.4 Phase 4: Channel Power Control Mode Fully Activated

The VOA reaches the final attenuation condition that leads the power value that is read on the photodiode to the expected target value (VOA Power Reference). Simultaneously, the VOA operating mode switches to power control mode.

From this point on, any further adjustment of the VOA attenuation is triggered by a variation of the value read on the photodiode. The aim of these adjustments is to always keep the power value equal to the power setpoint, with +/- 0.5 dBm as the minimum adjustment increment.

1.13.2 VOA Failure Scenarios

Several conditions can stop the startup procedure at an intermediate step, blocking the VOA (and the circuit activation, as a consequence) from completing activation of the power control mode. The scenarios in this section portray those conditions.

Root-cause identification can be performed based on the alarm raised and the power reading on the photodiode associated with the VOA.

1.13.2.1 Scenario A: Optical Power Level of the Incoming Signal Lower Than Minimum Allowed by MSTP Supported Optical Interfaces

This scenario is for a condition where a TXP or MXP card is directly connected to a 32MUX-O, 40MUX, 32WSS, or 40WSS-C card where power in is expressed as $P_{in} < -4.5$ dBm.

If the incoming power level is lower than the minimum allowed, the startup procedure always stops at Phase 1 (see [Figure 1-33](#)). This is the case even if the final VOA Power Reference reported in CTC is reachable.

The final conditions that CTC reports are:

- A LOS-P (OCH layer) alarm on the port associated with the VOA (see [Figure 1-33](#))
- A valid optical power value (different from the end of scale value of -50 dBm) in the Power field, but the value for Power is less than -33 dBm. (To view the Power field, in card view, click the **Provisioning > Parameters** tabs.)

Figure 1-33 LOS-P Indication on the VOA Port

The screenshot shows the ROADM - Cisco Transport Controller interface. The main window displays the configuration for ROADM slot 12 32 WSS. The status is Active, and the service state is unlocked-enabled. The interface shows a grid of ADD-RX ports (01-40) and their corresponding PT values (33-40). A red box highlights the ADD-RX ports 41-48, indicating a LOS-P alarm. The RX: TX: DROP: 69, EXP: 66, and COM: 68, 67 are also visible. The bottom section shows an Alarms table with a single entry for LOS-P.

Num	Ref	New	Date	Object	Port	Pa...	Sev	ST	SA	Cond	Description
2658	2658		08/17/05 13:35:34 CEST	CHAN-12-25...	57		CR	R		LOS-P	Incoming Payload Signal Absent

Use the following procedure to troubleshoot and eventually fix issues related to the VOA start-up when the optical power level of the incoming signal is lower than the minimum allowed by the MSTP supported optical interfaces.

Step 1 Verify the alarm validity:

- Identify the DWDM nodes where the alarmed card is seated.
- Double-click the card.
- Click **Alarms**.
- Verify that a LOS-P alarm is present on the ADD-RX port.
- Click the **Synchronize** button in the bottom left of the window.
- If the alarm is correctly reported, move to [Step 2](#). If not, close the CTC application, delete the CTC cache, and open the CTC connection again.



Note If the alarm inconsistency persists, log into the Technical Support Website at <http://www.cisco.com/techsupport> for more information or call Cisco TAC (1 800 553-2447) in order to report a service-affecting problem.

Step 2 If the alarmed card is a 32WSS or 40WSS-C, verify the incoming power level from the connected TXP, MXP, or line card. If the alarmed card is a 32MUX-O or 40MUX, go to [Step 5](#).

- a. Double-click the WSS card.
- b. Click the **Provisioning > Optical Chn: Optical Connector X > Parameters** tabs to display the optical power physically coming into the WSS ADD-RX port.



Note X is the number (1 to 45) of the appropriate multifiber MPO connector that manages the alarmed channel (wavelength).

- c. Identify the proper channel (wavelength) and read the Power ADD field.
- d. If the Power ADD value is less than -4.5 dBm, go to [Step 3](#). If not, click the **Provisioning > Optical Chn: Optical Connector X > Parameters** tabs.



Note X is the number (1 to 4) of the appropriate multifiber MPO connector that manages the alarmed channel (wavelength).

- e. Identify the correct row based on the **Type** field (the row must indicate Add in the type field).
- f. Decrease the attenuation on the VOA to the minimum (0 dB) to enable channel startup. To perform this adjustment:
 - Read the VOA Attenuation Ref value for the channel (wavelength).
 - Enter into the VOA Attenuation Calib field the same value as that of the VOA Attenuation Ref field, but with the opposite sign (the algebraic sum of the two contributions must be equal to zero).
 - Click **Apply**. If the LOS-P alarm persists, continue with this procedure. Otherwise, the problem has been corrected.
- g. In card view, click **Circuits**.
- h. Delete the OCHNC circuit that relates to the faulty channel.
- i. Ensure that the corresponding ADD-RX service state port changes to IS-AINS (or Unlocked,automaticInService) and that the color changes to grey (the LOS-P alarm should clear).
- j. Recreate the OCHNC circuit and verify that the Status field reports DISCOVERED and that the state is IS (Unlocked).
- k. If the LOS-P alarm has not cleared, replace the 32WSS card (refer to the “Add and Remove Cards and Nodes” chapter of the *Cisco ONS 15454 DWDM Procedure Guide*). Before you replace the card, log into the Technical Support Website at <http://www.cisco.com/techsupport> for more information or call Cisco TAC (1 800 553-2447) in order to report a service-affecting problem.



Warning

High-performance devices on this card can get hot during operation. To remove the card, hold it by the faceplate and bottom edge. Allow the card to cool before touching any other part of it or before placing it in an antistatic bag. Statement 201

Step 3 Because the actual power received by the WSS card is lower than expected, verify the correct behavior of the TXP, MXP, or line card connected to the WSS:

- The TX laser must be active (trunk port is in IS [or Unlocked] state).
- The wavelength provisioned must be the proper one.

- The output power value must be within the expected range (refer to the “Hardware Specifications” appendix in the *Cisco ONS 15454 DWDM Reference Manual*). If the trunk port PM is not available through CTC, perform a manual measurement using a standard power meter.

If the TX laser is active, the wavelength is provisioned properly, and the output power value is in the correct range, go to [Step 4](#). Otherwise, take the appropriate corrective action, including card replacement if the output power value is outside of the expected range (refer to the “Add and Remove Cards and Nodes” chapter of the *Cisco ONS 15454 DWDM Procedure Guide*. Replacing the card should correct the problem.)

**Warning**

High-performance devices on this card can get hot during operation. To remove the card, hold it by the faceplate and bottom edge. Allow the card to cool before touching any other part of it or before placing it in an antistatic bag. Statement 201

Step 4

If the TXP or MXP card behaves as expected, the only remaining root cause is the fiber connection between the two cards:

- Verify that the ADD_RX port of the alarmed WSS is connected to the TRUNK_TX port of the TXP or MXP card using an MPO-LC multifiber cable.

**Note**

A patch-panel tray is normally used to manage fiber connections (for patch-panel cabling details, refer to the “Turn Up a Node” chapter in the *Cisco ONS 15454 DWDM Procedure Guide*).

- Check and clean the LC fiber fan-out according to site practice. The fiber numbers (1 to 8) must correspond to the wavelength managed.
- If a patch panel is used, check and, if necessary, clean the LC-LC adapter. If necessary, replace any bad devices (maximum tolerance is 1 dB).
- Pull out the LC connector from the TRUNK_TX port of the TXP or MXP card and clean the fiber according to site practice.

**Note**

If no site practice exists for cleaning fibers, complete the procedure in the “Maintain the Node” chapter of the *Cisco ONS 15454 DWDM Procedure Guide*.

**Note**

If the alarm condition has not cleared, log into the Technical Support Website at <http://www.cisco.com/techsupport> for more information or call Cisco TAC (1 800 553-2447) in order to report a service-affecting problem.

Step 5

When the alarmed card is a 32MUX-O or 40MUX, the troubleshooting procedure should start from the TXP, MXP, or line card. Verify the correct behavior of the TXP, MXP, or line card connected to the 32MUX-O or 40MUX:

- The TX laser must be active (trunk port is in IS [or Unlocked] state).
- The wavelength provisioned must be the proper one.
- The output power value must be within the expected range (refer to the “Hardware Specifications” appendix in the *Cisco ONS 15454 DWDM Reference Manual*). If the trunk port PM is not available through CTC, perform a manual measurement using a standard power meter.

If the TX laser is active, the wavelength is provisioned properly, and the output power value is in the correct range, go to [Step 6](#). Otherwise, take the appropriate corrective action, including card replacement if the output power value is outside of the expected range (refer to the “Add and Remove Cards and Nodes” chapter of the *Cisco ONS 15454 DWDM Procedure Guide*. Replacing the card should correct the problem.)

**Warning**

High-performance devices on this card can get hot during operation. To remove the card, hold it by the faceplate and bottom edge. Allow the card to cool before touching any other part of it or before placing it in an antistatic bag. Statement 201

- Step 6** If the TXP or MXP card behaves as expected, check the fiber connection between the two cards:
- a. The ADD_RX port of the alarmed 32MUX-O or 40MUX must be connected to the TRUNK_TX port of a TXP or MXP card using an MPO-LC multifiber cable.



Note A patch-panel tray is normally used to manage fiber connections (for patch-panel cabling details, refer to the “Turn Up a Node” chapter in the *Cisco ONS 15454 DWDM Procedure Guide*).

- b. Check and clean the LC fiber fan-out according to site practice. The fiber numbers (1 to 8) must correspond to the wavelength managed.
- c. If a patch panel is used, check and, if necessary, clean the LC-LC adapter.
- d. If necessary, replace any bad devices (maximum tolerance is 1 dB).
- e. Pull out the LC connector from the TRUNK_TX port of the TXP or MXP card and clean the fiber according to site practice.



Note If no site practice exists for cleaning fibers, complete the procedure in the “Maintain the Node” chapter of the *Cisco ONS 15454 DWDM Procedure Guide*.

- f. If the alarm condition persists, move to [Step 7](#). Otherwise, the problem has been corrected.

- Step 7** Verify the correct behavior of the VOA inside the 32MUX-O or 40MUX card:

- a. Double-click the card.
- b. Click **Circuits**.
 - Delete the OCHNC circuit relating to the faulty channel.
 - Ensure that the service state of the corresponding ADD-RX port changes to IS-AINS (or Unlocked,automaticInService), and that the color turns grey (the LOS-P alarm should clear).
- c. In card view, click the **Provisioning > Optical Chn > Parameters** tabs and identify the proper channel (wavelength).
- d. Decrease the attenuation on the VOA to the minimum (0 dB) to enable channel startup. To perform this in field adjustment:
 - Read the VOA Attenuation Ref value for the channel (wavelength).
 - Enter the same value into the VOA Attenuation Calib field as that of the VOA Attenuation Ref field, but with the opposite sign (the algebraic sum of the two contributions must be equal to zero).

- Click **Apply**. If the LOS-P alarm persists, continue with this procedure. Otherwise, the problem has been corrected.
- e. Click **Circuits**.
- f. Recreate the OCHNC circuit and verify that Circuit Status field reports DISCOVERED and the state is IS (Unlocked).
- g. If the LOS-P alarm has not cleared, replace the 32MUX-O or 40MUX card (refer to the “Add and Remove Cards and Nodes” chapter of the *Cisco ONS 15454 DWDM Procedure Guide*). Before you replace the card, log into the Technical Support Website at <http://www.cisco.com/techsupport> for more information or call Cisco TAC (1 800 553-2447) in order to report a service-affecting problem).

**Warning**

High-performance devices on this card can get hot during operation. To remove the card, hold it by the faceplate and bottom edge. Allow the card to cool before touching any other part of it or before placing it in an antistatic bag. Statement 201

1.13.2.2 Scenario B: Optical Power Level of the Incoming Signal Lower Than Expected

In some cases, the pass-through channels on the WSS card or the optical bypass channels on the 32MUX-O or 40MUX card are at a power level that is lower than expected. The incoming power level can be lower than expected for several reasons. A few examples are:

- Dirty connections
- Excessive span loss
- Wrong amplifier gain setting

When the power is lower than expected, the start-up procedure can stop at Phase 1, Phase 2, or Phase 3 (see [Figure 1-32](#)). The point at which the start-up procedure stops depends on the amount of power missing.

Given that Delta Power is the amount of optical power missing compared to the expected value, two final conditions for Scenario B can be identified, Conditions B1 and B2.

1.13.2.2.1 Condition B1—Delta Power > 6 dB (LOS-P Alarm)

When the optical power is more than 6 dB lower than the expected value, the final VOA Power Reference setpoint value is definitively not reachable and even Phase 1 of the start-up procedure cannot be properly completed. As a consequence, the final condition reported in CTC is the same as that of Scenario A:

- A LOS-P (OCH layer) alarm is present on the port associated with the VOA.
- A valid optical power value (different from the end of scale value of – 50 dBm) can be read in the Power field, but the value for Power is less than –33 dBm (see [Figure 1-34](#)). (To access this value, in card view, click the **Provisioning > Parameters** tabs.)

Figure 1-34 Power Level of Incoming Signal Less than -33 dBm

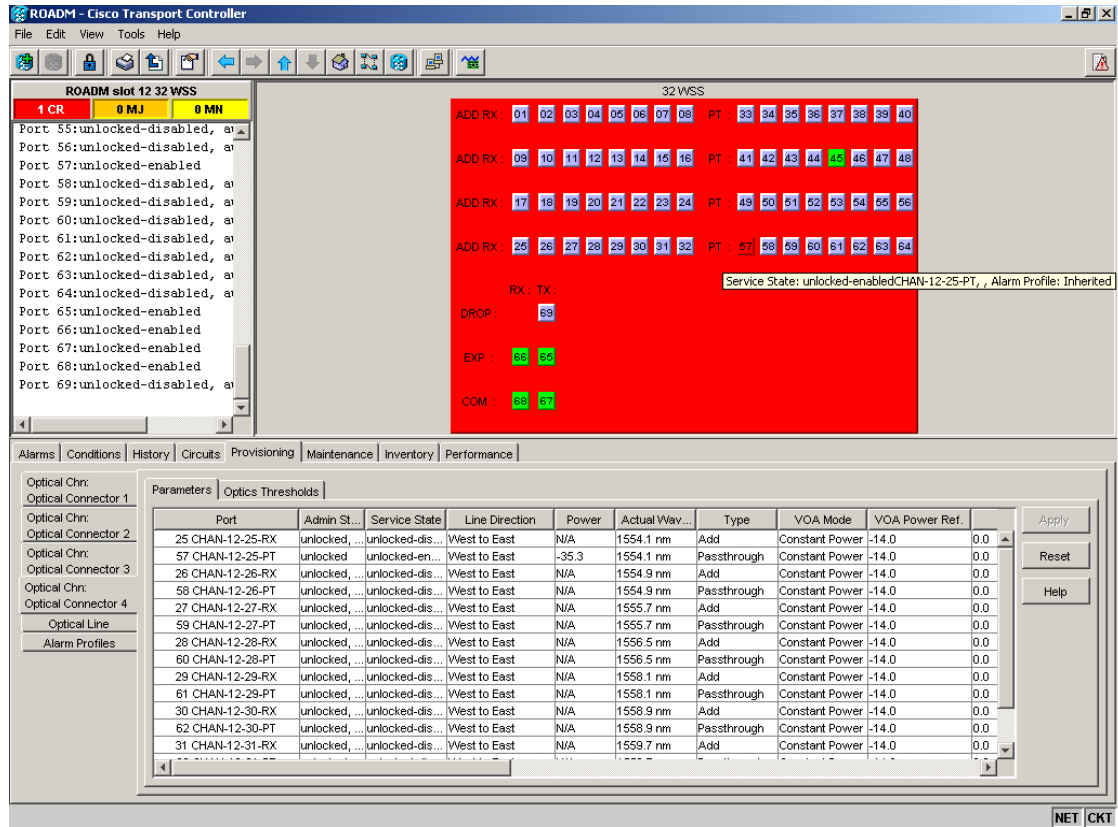

1.13.2.2.2 Condition B2—Delta Power < 6 dB (OPWR-LowDEGrade Alarm)

When the optical power is less than 6 dB lower than the expected value, even if a valid incoming signal is present, the final VOA Power Reference setpoint value that is reported in the CTC is not reachable and the VOA startup procedure is stopped at Phase 3.

The final conditions that CTC reports are:

- An OPWR-LowDEGrade (OCH layer) alarm is present on the port associated with the VOA.
- A valid optical power value (different from the end of scale value of -50 dBm) can be read in the Power field, but the value is (VOA Power Ref - 6 dBm) < Power < VOA Power Ref (see Figure 1-35). To access this value, in card view, click the **Provisioning** > **Parameters** tabs.

145184



Note If the alarm inconsistency persists, log into the Technical Support Website at <http://www.cisco.com/techsupport> for more information or call Cisco TAC (1 800 553-2447) in order to report a service-affecting problem.

Step 2 In card view, click **Circuits** and retrieve the node, card, and port information for the alarmed channel from the Source field of the OCHNC circuit. Then follow the procedures of [Step 3](#) (32MUX-O, 32WSS, 40MUX, 40WSS-C, or AD-xC-xx.x card) or [Step 4](#) (TXP, MXP, or line card) as appropriate.

Step 3 Verify the correct behavior of the far-end DWDM card (32MUX-O, 32WSS, 40MUX, 40WSS-C, or AD-xC-xx.x) that manages the channel (wavelength):

- a. Verify that the power value coming in on the ADD_RX port is correct.
 - In card view, click the **Provisioning > Optical Chn: Optical Connector X > Parameters** tabs.



Note X is number (1 to 45) of the proper multifiber MPO connector that manages the alarmed channel (wavelength).

- The Power field value must be the same as that in the VOA Power Ref field. If not, take the appropriate corrective actions according to the alarm raised at the RX-ADD port.

Step 4 Verify the correct behavior of the TXP, MXP, or line card that is the signal source of the channel (wavelength) that is alarmed:

- a. The TX laser must be active (trunk port is in IS [Unlocked] state).
- b. The wavelength provisioned must be the proper one.
- c. The output power value must be within the expected range (refer to the “Hardware Specifications” appendix in the *Cisco ONS 15454 DWDM Reference Manual*). If the trunk port PM is not available through CTC (for example, TXP_MR_2.5G), perform a manual measurement using a standard power meter.

Step 5 If the cards referenced in [Step 3](#) and [Step 4](#) are operating properly, go to [Step 6](#). If not, take the appropriate corrective actions according to the alarm raised on the card.

Step 6 If the alarmed card is a 32MUX-O or 40MUX, go to [Step 9](#).

Step 7 If the alarmed card is a 32WSS or 40MUX, continue with the following steps:

- a. Double-click the card.
- b. Click the **Provisioning > Optical Chn: Optical Connector X > Parameters** tabs.



Note X is number (1 to 45) of the proper multifiber MPO connector that manages the alarmed channel (wavelength).

- c. Identify the correct row based in the Type field (the row must indicate Passthrough in the type field).
- d. Decrease the attenuation on the VOA to the minimum (0 dB) to enable channel startup. To perform this in field adjustment:
 - Read the VOA Attenuation Ref value for the channel (wavelength).
 - Enter the same value into the VOA Attenuation Calib field as that of the VOA Attenuation Ref field, but with the opposite sign (the algebraic sum of the two contributions must be equal to zero).

- Click **Apply**. If the LOS-P alarm persists, continue with this procedure. Otherwise, the problem has been corrected.
- e. Click **Circuits**.
- f. Delete the OCHNC circuit for the faulty channel.
- g. Ensure that the service state of the corresponding ADD-RX port changes to IS-AINS (or Unlocked,automaticInService) and that the color changes to grey (LOS-P alarm should clear).
- h. Recreate the OCHNC circuit and verify that Circuit Status field reports DISCOVERED and the state is IS (Unlocked).
- i. If the LOS-P alarm has not cleared, continue with [Step 8](#). Otherwise, the problem has been corrected.

Step 8 To unambiguously pinpoint the root cause of the alarm, verify the proper cabling of the EXP_RX port (which is the common input port for all the pass-through channels) on the 32WSS or 4-WSS-C card:

- a. The EXP_RX port of the alarmed 32WSS card must be connected to the EXP_TX port of the coupled WSS card on the opposite side of the node.
- b. Pull out the LC connector from the EXP_RX port of the WSS card and clean the fiber according to site practice.
- c. Pull out the LC connector from the EXP_TX port of the coupled WSS card and clean that connector also.
- d. Verify that the fiber attenuation is within the specifications (maximum tolerance is 1 dB).
- e. If necessary, replace any bad fibers.



Note Before disconnecting any optical amplifier card fiber for troubleshooting, ensure that the optical amplifier card is unplugged.



Note If no site practice exists for cleaning fibers, complete the procedure in the “Maintain the Node” chapter of the *Cisco ONS 15454 DWDM Procedure Guide*.

- f. If the alarm condition persists even after the checking and fixing the fibers, replace the 32WSS card (refer to the “Add and Remove Cards and Nodes” chapter of the *Cisco ONS 15454 DWDM Procedure Guide*). Before replacing the card, log into the Technical Support Website at <http://www.cisco.com/techsupport> for more information or call Cisco TAC (1 800 553-2447) in order to report a service-affecting problem).



Warning

High-performance devices on this card can get hot during operation. To remove the card, hold it by the faceplate and bottom edge. Allow the card to cool before touching any other part of it or before placing it in an antistatic bag. Statement 201

Step 9 Verify the correct behavior of the VOA inside the 32MUX-O or 40MUX card:

- a. Double-click the 32MUX-O or 40MUX card.
- b. Click **Circuits**.
- c. Delete the OCHNC circuit for the faulty channel.
- d. Ensure that the service state of the corresponding ADD-RX port changes to IS-AINS (or Unlocked,automaticInService) and that the color changes to grey (LOS-P alarm should clear).

- e. Click the **Provisioning > Optical Chn > Parameters** tabs and identify the proper channel (wavelength).
- f. Decrease the attenuation on the VOA to the minimum (0 dB) to enable channel startup. To perform this in field adjustment:
 - Read the VOA Attenuation Ref value for the channel (wavelength).
 - Enter the same value into the VOA Attenuation Calib field as that of the VOA Attenuation Ref field, but with the opposite sign (the algebraic sum of the two contributions must be equal to zero).
 - Click the **Apply** button. If the LOS-P alarm persists, continue with this procedure. Otherwise, the problem has been corrected.
- g. Click **Circuits**.
- h. Recreate the OCHNC circuit and verify that Circuit Status field reports DISCOVERED and the state is IS (Unlocked).
- i. If the LOS-P alarm has not cleared, continue with [Step 10](#). Otherwise, the problem has been corrected.

- Step 10** To unambiguously pinpoint the root cause of the alarm, verify the proper cabling of the alarmed ADD_RX port on the 32MUX-O or 40MUX card:
- a. The ADD_RX port of the alarmed 32MUX-O or 40MUX must be connected to the DROP_TX port of the coupled 32DMX-O or 40DMX card on the opposite side of the node using two MPO-LC multifiber cables.

**Note**

A patch-panel tray is normally used to manage fiber connections (for patch-panel cabling details, refer to the “Turn Up a Node” chapter in the *Cisco ONS 15454 DWDM Procedure Guide*).

- b. Verify that the power value coming out of DROP_TX port of the coupled 32DMX-O or 40DMX card is correct:
 - In card view, click the **Provisioning > Optical Chn: > Parameters** tabs.
 - The Power field value must be the same as that in the VOA Power Ref field. If it is not, take the appropriate corrective action for the alarm according to [Chapter 2, “Alarm Troubleshooting.”](#)
- c. Check and clean the LC fiber fan-out according to site practice. The fiber numbers (1 to 8) must correspond to the wavelength managed.
- d. Repeat [Step c](#) for the MPO-LC multifiber cable coming out of the DROP_TX port of the coupled 32DMX-O or 40DMX card.
- e. Check and, if necessary, clean the LC-LC adapter.
- f. If necessary, replace and bad devices (maximum tolerance is 1 dB).



Note If no site practice exists for cleaning fibers, complete the procedure in the “Maintain the Node” chapter of the *Cisco ONS 15454 DWDM Procedure Guide*.

- g. If the alarm condition persists even after the cabling is checked or fixed, replace the 32MUX-O or 40MUX card (refer to the “Add and Remove Cards and Nodes” chapter of the *Cisco ONS 15454 DWDM Procedure Guide*. Before replacing the card, log into the Technical Support Website at <http://www.cisco.com/techsupport> for more information or call Cisco TAC (1 800 553-2447) in order to report a service-affecting problem).

**Warning**

High-performance devices on this card can get hot during operation. To remove the card, hold it by the faceplate and bottom edge. Allow the card to cool before touching any other part of it or before placing it in an antistatic bag. Statement 201

Condition B2—OPWR-LowDEGrade Alarm

- Step 1** Verify the alarm validity:
- Identify the DWDM node where the alarmed card is located.
 - Double-click the card (either the 32MUX-O, 32WSS, 40MUX, or 40WSS-C card).
 - Click **Alarms**.
 - Verify that an Optical Power Degradate Low (OPWR-LDEG) alarm is present on the ADD-RX port.
 - Click the **Synchronize** button at the bottom left of the window.
 - If the alarm is correctly reported, go to [Step 2](#). If not, close the CTC application, delete the CTC cache, and open the CTC connection again.



Note If the alarm inconsistency persists, log into the Technical Support Website at <http://www.cisco.com/techsupport> for more information or call Cisco TAC (1 800 553-2447) in order to report a service-affecting problem.

- Step 2** In card view, click **Circuits** and retrieve the node, card, and port information for the alarmed channel from the Source field of the OCHNC circuit. Then, follow the procedures in [Step 3](#) (for 32MUX-O, 32WSS, 40MUX, 40WSS-C, or AD-xC-xx.x cards) or [Step 4](#) (for TXP, MXP, or line cards) as appropriate.
- Step 3** Verify the correct behavior of the far-end DWDM card (32MUX-O, 32WSS, 40MUX, 40WSS-C, or AD-xC-xx.x) that manages the channel (wavelength). To do this, verify that the power value coming in on the ADD_RX port is correct:
- In card view, click the **Provisioning > Optical Chn: Optical Connector X > Parameters** tabs.



Note X is number (1 to 45) of the proper multi-fibers MPO connector that manages the alarmed channel (wavelength).

- The Power field value must be the same as the VOA Power Ref field. If it is not, take the appropriate corrective action for the alarm according to [Chapter 2, “Alarm Troubleshooting.”](#)
- Step 4** Verify the correct behavior of the TXP, MXP, or line card that is the signal source of the channel (wavelength) that is alarmed:
- The TX laser must be active (trunk port is in IS [unlocked] state).
 - The wavelength provisioned must be the proper one.
 - The output power value must be within the expected range (refer to the “Hardware Specifications” appendix in the *Cisco ONS 15454 DWDM Reference Manual*). If the trunk port PM is not available through CTC, perform a manual measurement using a standard power meter.

- Step 5** If the cards referenced in [Step 3](#) and [Step 4](#) are operating properly, go to [Step 6](#). If not, take the appropriate corrective actions according to the alarm raised on the card (see [Chapter 2, “Alarm Troubleshooting”](#)).
- Step 6** If the alarmed card is a 32MUX-O or 40MUX card, go to [Step 8](#).
- Step 7** If the alarmed card is a 32WSS or 40WSS-C card, verify the proper cabling of the EXP_RX port (common input port for all pass-through channels) on the WSS card:
- Verify that the EXP_RX port of the alarmed WSS card is connected to the EXP_TX port of the coupled WSS card on the opposite side of the node.
 - Pull out the LC connector from the EXP_RX port of the WSS card and clean the fiber according to site practice.
 - Pull out the LC connector from the EXP_TX port of the coupled WSS card and clean its connector also.
 - Verify that the fiber attenuation is within the specifications (maximum tolerance is 1 dB).
 - If necessary, replace any bad fibers.



Note Before disconnecting any optical amplifier card fiber for troubleshooting, ensure that the optical amplifier card is unplugged.



Note If no site practice exists for cleaning fibers, complete the procedure in the “Maintain the Node” chapter of the *Cisco ONS 15454 DWDM Procedure Guide*.



Note If the alarm condition persists even after the cabling check/fixing, the root cause could be related to a network issue and a more accurate analysis of the signal flow is needed according to the actual system topology. If necessary, call Cisco TAC (1 800 553-2447) for help.

- Step 8** Verify the proper cabling of the alarmed ADD_RX port on the 32MUX-O or 40MUX card:
- Verify that the ADD_RX port of the alarmed 32MUX-O or 40MUX is connected to the DROP_TX port of the coupled 32DMX-O or 40DMX card on the opposite side of the node, using two MPO-LC multifiber cables.



Note A patch-panel tray is normally used to manage fiber connections (for patch-panel cabling details, refer to the “Turn Up a Node” chapter in the *Cisco ONS 15454 DWDM Procedure Guide*).

- Verify that the power value coming out of the DROP_TX port of the coupled 32DMX-O card is correct:
 - In card view, click the **Provisioning > Optical Chn > Parameters** tabs.
 - The Power field value must be the same as that in the VOA Power Ref field. If it is not, take the appropriate corrective action for the alarm according to [Chapter 2, “Alarm Troubleshooting.”](#)
- Check (the number [1 to 8] must correspond with the wavelength managed) and clean the LC fan-out according to site practice.
- Repeat [Step c](#) for the MPO-LC multifiber cable coming out of the DROP_TX port of the coupled 32DMX-O or 40DMX card.

- e. Check and, if necessary, clean the LC-LC adapter used.
- f. If necessary, replace any bad devices (maximum tolerance is 1 dB).



Note If no site practice exists for cleaning fibers, complete the procedure in the “Maintain the Node.” chapter of the *Cisco ONS 15454 DWDM Procedure Guide*.



Note If the alarm condition persists even after the cable check and repair procedures, the root cause could be related to a network issue and a more accurate analysis of the signal flow is needed according with the actual system topology. If necessary, call Cisco TAC (1 800 553-2447) for help.

1.13.2.3 Scenario C: Optical Drop Power Level Lower Than Expected

This scenario describes the condition in which the optical power at the 32DMX-O or 40DMX drop channels is lower than expected. The 32DMX-O card is equipped with a VOA for each wavelength, and each VOA manages the power for one dropped wavelength.

The failing scenarios during the OCHNC turn-up and consequent VOA startup are the same as those described in the “[1.13.2.2 Scenario B: Optical Power Level of the Incoming Signal Lower Than Expected](#)” section on page 1-92. The only difference is the type of alarm that is raised when the condition exists in which Delta Power is greater than 6 dB.

1.13.2.3.1 Condition C1—Delta Power > 6 dB Lower than Expected

When the optical power on the dropped channel is more than 6 dB lower than the value expected, the final VOA Power Reference setpoint value is definitively not reachable. As a consequence, the final conditions reported in CTC are as follows:

- An OPWR-LFAIL (OCH layer) alarm is present on the port associated with the VOA (see [Figure 1-36](#)).
- A valid optical power value (different from the end of scale value of -50 dBm) can be read in the CTC Power field, but the Power value is less than -33 dBm. (To view this value in card view, click the **Provisioning > Parameters** tabs.)

Figure 1-36 Optical Drop Power More than 6 dB Lower than Expected

The screenshot displays the ROADM - Cisco Transport Controller interface. The main window shows the configuration for ROADM slot 14 32 DMXO. On the left, a list of ports from 8 to 31 is shown with their status (e.g., 'unlocked-disabled, au'). On the right, a 32 DMXO card is visualized with 32 channels. Channels 01-08, 09-16, 17-24, and 25-32 are labeled as 'CHAN TX', and channel 33 is labeled as 'COM RX'. Channel 13 is highlighted in green. Below the card, an Alarms table is visible, showing an active alarm for 'Optical Power Failure Low' on channel 25.

Num	Ref	New	Date	Object	Port	Pa...	Sev	ST	SA	Cond	Description
2743	2743	✓	08/17/05 15:43:23 CEST	CHAN-14-25...	25		CR	R	✓	OPWR-LFAIL	Optical Power Failure Low

1.13.2.3.2 Condition C2—Delta Power < 6 dB Lower than Expected

If the delta power is less than 6 dB lower than expected, the final conditions reported in CTC are the same as those reported for Condition B2 (see the “1.13.2.2.2 Condition B2—Delta Power < 6 dB (OPWR-LowDEGrade Alarm)” section on page 1-93):

- An OPWR-LowDEGrade (OCH layer) alarm is present on the port associated with the VOA.
- A valid optical power value (different from the end of scale value of -50 dBm) can be read in the CTC Power field, but the value is $(\text{VOA Power Ref} - 6 \text{ dBm}) < \text{Power} < \text{VOA Power Ref}$ (Figure 1-35). To view this value in card view, click the **Provisioning > Parameters** tabs.

A dirty connection or excessive loss of the incoming span are among the possible reasons that can lead to a fault condition. They are the most common and affect all wavelengths, whereas an excessive amplifier gain tilt or a wavelength misconfiguration on the far-end TXP or MXP card can lead to condition where only a single wavelength fails, such as the one (Channel 25) shown in Figure 1-37.

Figure 1-37 Optical Drop Power Less than 6 dB Lower than Expected

Port	Admin St.	Service State	Line Direction	Power	Actual Wav...	Type	VOA Mode	VOA Power Ref.	VOA
7 CHAN-14-7-TX	unlocked, ...	unlocked-dis...	East to West	-48.7	1536.0 nm	Drop	Constant Power	-14.0	0.0
8 CHAN-14-8-TX	unlocked, ...	unlocked-dis...	East to West	-48.7	1536.6 nm	Drop	Constant Power	-14.0	0.0
9 CHAN-14-9-TX	unlocked, ...	unlocked-dis...	East to West	-48.4	1538.1 nm	Drop	Constant Power	-14.0	0.0
10 CHAN-14-10-TX	unlocked, ...	unlocked-dis...	East to West	-49.0	1538.9 nm	Drop	Constant Power	-14.0	0.0
11 CHAN-14-11-TX	unlocked, ...	unlocked-dis...	East to West	-48.6	1539.7 nm	Drop	Constant Power	-14.0	0.0
12 CHAN-14-12-TX	unlocked, ...	unlocked-dis...	East to West	-48.6	1540.5 nm	Drop	Constant Power	-14.0	0.0
13 CHAN-14-13-TX	unlocked, ...	unlocked-en...	East to West	-13.9	1542.1 nm	Drop	Constant Power	-14.0	0.0
14 CHAN-14-14-TX	unlocked, ...	unlocked-dis...	East to West	-48.2	1542.9 nm	Drop	Constant Power	-14.0	0.0
15 CHAN-14-15-TX	unlocked, ...	unlocked-dis...	East to West	-48.5	1543.7 nm	Drop	Constant Power	-14.0	0.0
16 CHAN-14-16-TX	unlocked, ...	unlocked-dis...	East to West	-48.5	1544.5 nm	Drop	Constant Power	-14.0	0.0
17 CHAN-14-17-TX	unlocked, ...	unlocked-dis...	East to West	-48.4	1546.1 nm	Drop	Constant Power	-14.0	0.0
18 CHAN-14-18-TX	unlocked, ...	unlocked-dis...	East to West	-47.4	1546.9 nm	Drop	Constant Power	-14.0	0.0
19 CHAN-14-19-TX	unlocked, ...	unlocked-dis...	East to West	-48.7	1547.7 nm	Drop	Constant Power	-14.0	0.0
20 CHAN-14-20-TX	unlocked, ...	unlocked-dis...	East to West	-49.0	1548.5 nm	Drop	Constant Power	-14.0	0.0
21 CHAN-14-21-TX	unlocked, ...	unlocked-dis...	East to West	-47.2	1550.1 nm	Drop	Constant Power	-14.0	0.0
22 CHAN-14-22-TX	unlocked, ...	unlocked-dis...	East to West	-47.6	1550.9 nm	Drop	Constant Power	-14.0	0.0
23 CHAN-14-23-TX	unlocked, ...	unlocked-dis...	East to West	-48.3	1551.7 nm	Drop	Constant Power	-14.0	0.0
24 CHAN-14-24-TX	unlocked, ...	unlocked-dis...	East to West	-47.6	1552.5 nm	Drop	Constant Power	-14.0	0.0
25 CHAN-14-25-TX	unlocked, ...	unlocked-en...	East to West	-34.2	1554.1 nm	Drop	Constant Power	-14.0	0.0

Corrective Action for Scenario C (Optical Power Level of Incoming Signal Lower than Expected)

Scenario C1 - LOS-P Alarm

- Step 1** Verify the alarm validity:
- Identify the DWDM nodes where the alarmed card is located.
 - Double-click the 32DMX-O or 40DMX card.
 - Click **Alarms**.
 - Verify that a LOS-P alarm is present on the CHAN-TX port.
 - Click the **Synchronize** button at the bottom left of the window.
 - If the alarm is correctly reported, move to **Step 2**. If not, close the CTC application, delete the CTC cache, and open the CTC connection again.



Note If the alarm inconsistency persists, log into the Technical Support Website at <http://www.cisco.com/techsupport> for more information or call Cisco TAC (1 800 553-2447) in order to report a service-affecting problem.

- Step 2** Verify the correct behavior of the far-end DWDM card (32MUX-O, 32WSS, 40MUX, 40WSS-C, AD-xC-xx.x) that manages the channel (wavelength), and the TXP, MXP, or line card that is the signal source of the channel (wavelength) alarmed:
- Click **Circuits** and retrieve the node, card, and port information for the alarmed channel from the Source field of the OCHNC circuit.
 - For the far-end DWDM card, verify that the power value coming in the ADD_RX port is correct:
 - In card view, click the **Provisioning > Optical Chn: Optical Connector X > Parameters** tabs.



Note X is number (1 to 45) of the proper multifiber MPO connector that manages the alarmed channel (wavelength).

- The Power field value must be the same of VOA Power Ref field. If not, take the appropriate corrective actions according to [Chapter 2, “Alarm Troubleshooting.”](#)
- For the corresponding TXP, MXP, or line card connected, verify the following:
 - The TX laser is active (the trunk port is in IS [Unlocked] state).
 - The wavelength provisioned is the proper one.
 - The output power value must be within the expected range (refer to the “Hardware Specifications” appendix in the *Cisco ONS 15454 DWDM Reference Manual*). If the trunk port PM is not available through CTC (for example, TXP_MR_2.5G), perform a manual measurement using a standard power meter.
 - If everything in [Step 2](#) is correct, go to [Step 3](#). If not, take the appropriate corrective actions according to [Chapter 2, “Alarm Troubleshooting.”](#)
- Step 3** Verify the correct behavior of the VOA inside the 32DMX-O or 40DMX card:
- Double-click the 32DMX-O or 40DMX card.
 - Click **Circuits**.
 - Delete the OCHNC circuit for the faulty channel.
 - Ensure that the service state of the corresponding CHAN-TX port changes to IS-AINS (or Unlocked,automaticInService) and the color changes to grey (LOS-P alarm should clear).
 - Click the **Provisioning > Optical Chn > Parameters** tabs and identify the proper channel (wavelength).
 - Decrease the attenuation on the VOA to the minimum (0 dB) to enable channel startup. To perform this in field adjustment:
 - Read the **VOA Attenuation Ref** value for the channel (wavelength).
 - Enter the same value into the VOA Attenuation Calib field as that in the VOA Attenuation Ref field, but with the opposite sign (the algebraic sum of the two contributions must be equal to zero).
 - Click **Apply**.
 - Click **Circuits**.
 - Recreate the OCHNC circuit and verify that Circuit Status field reports DISCOVERED and the state is IS (Unlocked).
 - If the LOS-P alarm has not cleared, continue with [Step 4](#). If it has cleared, you are finished.

- Step 4** To unambiguously pinpoint the root cause of the alarm, verify the proper cabling of the COM-RX port (common input port for all the drop channels) of the alarmed 32DMX-O or 40DMX card:
- Verify that the COM_RX port of the alarmed 32DMX-O or 40DMX is connected either to the DROP_TX port of a 32WSS or 40WSS-C card or to the COM_TX port of an OPT-PRE, OPT-BST/OPT-AMP-x-C, or OSC-CSM card, depending on the actual node layout.
 - Pull out the LC connector from the COM_RX port of the 32DMX-O or 40DMX card and clean the fiber according to site practice.
 - Pull out the LC connector from the COM_TX or DROP_TX port of the connected DWDM card and clean the fiber according to site practice.
 - Verify that the fiber attenuation is within the specifications (maximum tolerance is 1 dB).
 - If necessary, replace any bad fibers.

**Warning**

Invisible laser radiation may be emitted from the end of the unterminated fiber cable or connector. Do not view directly with optical instruments. Viewing the laser output with certain optical instruments (for example, eye loupes, magnifiers, and microscopes) within a distance of 100 mm may pose an eye hazard. Statement 1056



Note Before disconnecting any optical amplifier card fiber for troubleshooting, ensure that the optical amplifier card is unplugged.



Note If no site practice exists for cleaning fibers, complete the procedure in the “Maintain the Node” chapter of the *Cisco ONS 15454 DWDM Procedure Guide*.

- If the alarm condition persists even after the cabling has been checked and fixed, replace the 32DMX-O card (refer to the “Add and Remove Cards and Nodes” chapter of the *Cisco ONS 15454 DWDM Procedure Guide*. Before replacing the card, log into the Technical Support Website at <http://www.cisco.com/techsupport> for more information or call Cisco TAC (1 800 553-2447) in order to report a service-affecting problem).

**Warning**

High-performance devices on this card can get hot during operation. To remove the card, hold it by the faceplate and bottom edge. Allow the card to cool before touching any other part of it or before placing it in an antistatic bag. Statement 201

Scenario C2 - OPWR-LowDEGrade Alarm

- Step 1** Verify the alarm validity:
- Identify the DWDM nodes where the alarmed card is seated.
 - Double-click the 32DMX-O or 40DMX card.
 - Click **Alarms**.
 - Verify that an Optical Power Degrade Low Loss of incoming Payload (OPWR-LDEG) alarm is present on the CHAN-TX port.

- e. Click the **Synchronize** button at the bottom left of the window.
- f. If the alarm is correctly reported, move to [Step 2](#). If not, close the CTC application, delete the CTC cache, and open the CTC connection again.



Note If the alarm inconsistency persists, log into the Technical Support Website at <http://www.cisco.com/techsupport> for more information or call Cisco TAC (1 800 553-2447) in order to report a service-affecting problem.

- Step 2** Verify the correct behavior of the far-end DWDM card (32MUX-O, 32WSS, 40MUX, 40WSS-C, or AD-xC-xx.x) that manages the channel (wavelength) and the TXP, MXP, or line card that is the signal source of the channel (wavelength) alarmed.
- a. Click **Circuits** and retrieve the node, card, and port information for to the alarmed channel from the Source field of the OCHNC circuit.
 - b. For the far-end DWDM card, verify that the power value coming in on the ADD_RX port is correct:
 - In card view, click the **Provisioning > Optical Chn: Optical Connector X > Parameters** tabs.



Note X is number (1 to 45) of the proper multifiber MPO connector that manages the alarmed channel (wavelength).

- The Power field value must be the same of VOA Power Ref field. If not, take the appropriate corrective actions according to [Chapter 2, “Alarm Troubleshooting.”](#)
- c. For the corresponding TXP, MXP, or line card connected, verify the following:
 - The TX laser is active (the trunk port is in IS [Unlocked] state).
 - The wavelength provisioned is the proper one.
 - d. The output power value must be within the expected range (refer to the “Hardware Specifications” appendix in the *Cisco ONS 15454 DWDM Reference Manual*). If the trunk port PM is not available through CTC, perform a manual measurement using a standard power meter.
 - e. If everything in [Step 2](#) is correct, move to [Step 3](#). If not, take the appropriate corrective actions according to [Chapter 2, “Alarm Troubleshooting.”](#)

- Step 3** Verify the proper cabling of the COM-RX port (the common input port for all of the drop channels) of the alarmed 32DMX-O or 40DMX:
- a. Verify that the COM_RX port of the alarmed 32DMX-O or 40DMX is connected either to the DROP_TX port of a 32WSS or 40WSS-C card or to the COM_TX port of an OPT-PRE, OPT-BST/OPT-AMP-x-C, or OSC-CSM, depending on the actual node layout.
 - b. Pull out the LC connector from the COM_RX port of the 32DMX-O or 40DMX card and clean the fiber according to site practice.
 - c. Pull out the LC connector from the COM_TX or DROP_TX port of the connected DWDM card and clean the fiber according to site practice.
 - d. Verify that the fiber attenuation is within the specifications (maximum tolerance is 1 dB).
 - e. If necessary, replace any bad fibers.

**Warning**

Invisible laser radiation may be emitted from the end of the unterminated fiber cable or connector. Do not view directly with optical instruments. Viewing the laser output with certain optical instruments (for example, eye loupes, magnifiers, and microscopes) within a distance of 100 mm may pose an eye hazard. Statement 1056

**Note**

Before disconnecting any optical amplifier card fiber for troubleshooting, ensure that the optical amplifier card is unplugged.

**Note**

If no site practice exists for cleaning fibers, complete the procedure in the “Maintain the Node” chapter in the *Cisco ONS 15454 DWDM Procedure Guide*.

- f. If the alarm condition persists even after the cabling has been checked and fixed, the root cause could be related to a network issue and a more accurate analysis of the signal flow is needed according to the actual system topology. If necessary, call Cisco TAC (1 800 553-2447) in order to report a service-affecting problem.

1.13.3 Counter-Propagating Light Affecting Operation of 32DMX-C and 32DMX-L Cards

Symptom The in-service operation of the 32DMX-C and 32DMX-L cards (with vendor ID 2049 and 2050) can be seriously affected by the counter-propagating light travelling from the drop ports of the card towards the COM RX port. This counter-propagating light affects the internal VOA control loop of the vendor-specific optical module of the 32DMX-C and 32DMX-L cards, leading to an increased optical path attenuation. This is traffic affecting for all in-service channels.

Possible Cause The counter-propagating light can be inserted into the 32DMX-C or 32DMX-L card as a result of incorrect cabling of transponder or line cards to the fiber patch-panel (in particular, swapping RX with TX patchcords).

Recommended Action For software releases higher than or equal to 9.0, the vendor-specific optical module on all the cards is automatically upgraded to a newer version. The vendor ID of the new version of the card is 2051 and can be viewed at **CTC > Card View > Inventory** tab. This new version of the optical module makes the VOA control robust to counter-propagating light, thus, minimizing the effects of incorrect cabling during installation and/or maintenance.

For software releases lower than 9.0, for new 32DMX-C and 32DMX-L cards that are not already installed, the vendor-specific optical module on all these new cards is automatically upgraded to a newer version at the Cisco Spare depots. Once the new card is installed in field, a downgrade of the optical module will be prevented and the latest optical module version is preserved on the software package. If the 32DMX-C or 32DMX-L card is already installed, complete the [“Corrective Action—Software Releases Lower than 9.0” procedure on page 1-107](#) to manually fix the problem.

Corrective Action—Software Releases Lower than 9.0

-
- Step 1** If the TXP card is preprovisioned in CTC, but not installed:
- Log into CTC.
 - Display card view for the TXP card.
 - Click the **Provisioning > Line** tab and choose **OOS,DSBLD (ANSI)** or **Locked,disabled (ETSI)** from the Admin State drop-down list for the Trunk-TX port.
 - Continue with [Step 2](#)
- Step 2** Install the TXP card into the receptacle at the back of the designated slot.
- Step 3** Wait for the TXP card to boot completely.
- Step 4** Verify that the Trunk-TX port of the TXP card is in OOS,DSBLD (ANSI) or Locked,disabled (ETSI) state.
- Step 5** Wire the Trunk-TX/RX port of the TXP card to the fiber patch-panel.
- Step 6** Turn up the TXP card and display card view for the TXP card in CTC.
- Step 7** Click the **Provisioning > Line** tab and choose **IS,AINS (ANSI)** or **Unlocked,automaticInService (ETSI)** from the Admin State drop-down list for the Trunk-TX port.
- Step 8** Display card view for the 32WSS card.
- Step 9** Click the Performance > Optical Chn tab and verify the Power ADD field on the CHAN-RX port of the 32WSS card connected to the TXP card.
- If a valid power level exists, the cabling of the TXP card is correct. Change the admin state of the Trunk-TX port of the TXP card back to the original state.
 - If no power level exists, the cabling of the TXP card is incorrect. Change the admin state of the Trunk-TX port of the TXP card to OOS,DSBLD (ANSI) or Locked,disabled (ETSI) state and reverse the cabling.



Note It is important that you perform Steps 7 to 9 in the shortest time possible. That is, you must check the presence of a valid RX power on WSS card ([Step 9](#)) immediately after you turn up the TXP Trunk-TX port ([Step 7](#)), and in case of a bad connection, you must shut off the TXP Trunk-TX port ([Step 9b](#)) as soon as possible. This is to minimize possible impairments on other channels that are already in service.



CHAPTER 2

Alarm Troubleshooting

This chapter gives a description, severity, and troubleshooting procedure for each commonly encountered Cisco DWDM alarm and condition. Tables 2-1 through 2-5 provide lists of DWDM alarms organized by severity. Table 2-6 on page 2-8 provides a list of alarms organized alphabetically. Table 2-7 gives definitions of all DWDM alarm logical objects, which are the basis of the alarm profile list in Table 2-8 on page 2-17. For a comprehensive list of all conditions and instructions for using TL1 commands, refer to the *Cisco ONS SONET TL1 Command Guide*.

An alarm's troubleshooting procedure applies to both the Cisco Transport Controller (CTC) and TL1 version of that alarm. If the troubleshooting procedure does not clear the alarm, log into the Technical Support Website at <http://www.cisco.com/techsupport> for more information or call the Cisco Technical Assistance Center (1-800-553-2447).

For more information about alarm profiles, refer to the “Manage Alarms” chapter in the *Cisco ONS 15454 DWDM Procedure Guide*.



Note

Unless otherwise noted, ONS 15454 refers to the ANSI and ETSI versions of the platform.

2.1 Alarm Indexes

The following tables group alarms and conditions by their default severities in the ONS DWDM system. These severities are the same whether they are reported in the CTC Alarms window severity (SEV) column or in TL1.



Note

The CTC default alarm profile contains some alarms or conditions that are not currently implemented but are reserved for future use.



Note

The CTC default alarm profile in some cases contains two severities for one alarm (for example, MJ/MN). The platform default severity comes first (in this example, MJ), but the alarm can be demoted to the second severity in the presence of a higher-ranking alarm. This is in accordance with Telcordia GR-474.

2.1.1 Critical Alarms (CR)

Table 2-1 alphabetically lists Critical (CR) DWDM alarms.

Table 2-1 Critical DWDM Alarm List

—	HP-UNEQ (VCMON-HP)	OPWR-HFAIL (AOTS)
—	HP-UNEQ (VCTRM-HP)	OPWR-HFAIL (OCH)
AU-LOP (VCMON-HP)	I-HITEMP (NE)	OPWR-HFAIL (OMS)
AU-LOP (VCTRM-HP)	ILK-FAIL (TRUNK)	OPWR-HFAIL (OTS)
AUTOLSROFF (OCN)	IMPROPRMVL (EQPT)	OPWR-LFAIL (AOTS)
AWG-FAIL (OTS)	IMPROPRMVL (PPM)	OPWR-LFAIL (OCH-TERM)
AWG-OVERTEMP (OTS)	LOF (TRUNK)	OPWR-LFAIL (OCH)
BKUPMEMP (EQPT)	LOM (TRUNK)	OPWR-LFAIL (OMS)
CONTBUS-DISABLED (EQPT)	LOP-P (STSMON)	OPWR-LFAIL (OTS)
ENCAP-MISMATCH-P (POS)	LOP-P (STSTRM)	OTUK-LOF (TRUNK)
ENCAP-MISMATCH-P (STSTRM)	LOS (2R)	OTUK-TIM (TRUNK)
EQPT (AICI-AEP)	LOS (ESCON)	PORT-FAIL (OCH)
EQPT (AICI-AIE)	LOS (ISC)	RS-TIM (STMN)
EQPT-DIAG (EQPT)	LOS (OTS)	TIM (TRUNK)
EQPT (EQPT)	LOS (TRUNK)	TIM-P (STSTRM)
EQPT (PPM)	LOS-P (OCH)	TIM-S (OCN)
EQPT-MISS (FAN)	LOS-P (OMS)	UNEQ-P (STSMON)
FAN (FAN)	LOS-P (OTS)	UNEQ-P (STSTRM)
GAIN-HFAIL (AOTS)	LOS-P (TRUNK)	VOA-DISABLED (EQPT)
GAIN-LFAIL (AOTS)	LOS-RAMAN (OTS)	VOA-HFAIL (AOTS)
GE-OOSYNC (FC)	MEA (AIP)	VOA-HFAIL (OCH)
GE-OOSYNC (GE)	MEA (EQPT)	VOA-HFAIL (OMS)
GE-OOSYNC (ISC)	MEA (FAN)	VOA-HFAIL (OTS)
GE-OOSYNC (TRUNK)	MEA (PPM)	VOA-LFAIL (AOTS)
HITEMP (NE)	MFGMEM (AICI-AEP)	VOA-LFAIL (OCH)
HP-ENCAP-MISMATCH (VCTRM-HP)	MFGMEM (AICI-AIE)	VOA-LFAIL (OMS)
HP-PLM (VCMON-HP)	MFGMEM (BPLANE)	VOA-LFAIL (OTS)
HP-PLM (VCTRM-HP)	MFGMEM (FAN)	—
HP-TIM (VCMON-HP)	MFGMEM (PPM)	—

2.1.2 Major Alarms (MJ)

Table 2-2 alphabetically lists Major (MJ) DWDM alarms.

Table 2-2 Major DWDM Alarm List

APSCNMIS (OCN)	GFP-LFD (CE100T)	ODUK-TIM-PM (TRUNK)
BAT-FAIL (PWR)	GFP-LFD (CE1000)	OUT-OF-SYNC (FC)
CARLOSS (EQPT)	GFP-LFD (CEMR)	OUT-OF-SYNC (GE)
CARLOSS (FC)	GFP-LFD (FCMR)	OUT-OF-SYNC (TRUNK)
CARLOSS (GE)	GFP-LFD (GFP-FAC)	PEER-NORESPONSE (EQPT)
CARLOSS (ISC)	GFP-LFD (ML100T)	PROV-MISMATCH (TRUNK)
CARLOSS (TRUNK)	GFP-LFD (ML1000)	PTIM (TRUNK)
DBOSYNC (NE)	GFP-LFD (MLMR)	PWR-PROT-ON (OTS)
DSP-COMM-FAIL (TRUNK)	GFP-LFD (POS)	RING-ID-MIS (OSC-RING)
DSP-FAIL (TRUNK)	GFP-UP-MISMATCH (CE100T)	SHELF-COMM-FAIL (SHELF)
DUP-SHELF-ID (SHELF)	GFP-UP-MISMATCH (CE1000)	SIGLOSS (ESCON)
EHIBATVG (PWR)	GFP-UP-MISMATCH (CEMR)	SIGLOSS (FC)
ELWBATVG (PWR)	GFP-UP-MISMATCH (FCMR)	SIGLOSS (GE)
FC-NO-CREDITS (FC)	GFP-UP-MISMATCH (GFP-FAC)	SIGLOSS (ISC)
FC-NO-CREDITS (TRUNK)	GFP-UP-MISMATCH (ML100T)	SIGLOSS (TRUNK)
FEC-MISM (TRUNK)	GFP-UP-MISMATCH (ML1000)	SYNCLOSS (FC)
GFP-CSF (CE100T)	GFP-UP-MISMATCH (MLMR)	SYNCLOSS (GE)
GFP-CSF (CE1000)	GFP-UP-MISMATCH (POS)	SYNCLOSS (ISC)
GFP-CSF (CEMR)	HIBATVG (PWR)	SYNCLOSS (TRUNK)
GFP-CSF (FCMR)	INVMACADR (AIP)	SYNCPRI (NE-SREF)
GFP-CSF (GFP-FAC)	LASERBIAS-FAIL (AOTS)	SYSBOOT (NE)
GFP-CSF (ML100T)	LWBATVG (PWR)	UT-COMM-FAIL (TRUNK)
GFP-CSF (ML1000)	MEA (SHELF)	UT-FAIL (TRUNK)
GFP-CSF (MLMR)	MEM-GONE (EQPT)	WVL-MISMATCH (TRUNK)

2.1.3 Minor Alarms (MN)

Table 2-3 alphabetically lists Minor (MN) DWDM alarms.

Table 2-3 Minor DWDM Alarm List

—	HI-LASERBIAS (OCN)	LO-TXPOWER (ESCON)
—	HI-LASERBIAS (PPM)	LO-TXPOWER (FC)
AMPLI-INIT (AOTS)	HI-LASERBIAS (TRUNK)	LO-TXPOWER (GE)
APC-CORR-SKIPPED (AOTS)	HI-LASERTEMP (EQPT)	LO-TXPOWER (ISC)
APC-CORR-SKIPPED (OCH)	HI-LASERTEMP (OCN)	LO-TXPOWER (OCN)
APC-CORR-SKIPPED (OMS)	HI-LASERTEMP (PPM)	LO-TXPOWER (PPM)
APC-CORR-SKIPPED (OTS)	HI-RXPOWER (2R)	LO-TXPOWER (TRUNK)

Table 2-3 Minor DWDM Alarm List (continued)

APC-OUT-OF-RANGE (AOTS)	HI-RXPOWER (ESCON)	MEM-LOW (EQPT)
APC-OUT-OF-RANGE (OCH)	HI-RXPOWER (FC)	MS-EOC (STMN)
APC-OUT-OF-RANGE (OMS)	HI-RXPOWER (GE)	NON-CISCO-PPM (PPM)
APC-OUT-OF-RANGE (OTS)	HI-RXPOWER (ISC)	OPWR-HDEG (AOTS)
APS-INV-PRIM (OCN)	HI-RXPOWER (OCN)	OPWR-HDEG (OCH-TERM)
APS-PRIM-FAC (OCN)	HI-RXPOWER (TRUNK)	OPWR-HDEG (OCH)
APS-PRIM-SEC-MISM (OCN)	HITEMP (EQPT)	OPWR-HDEG (OMS)
APSB (OCN)	HI-TXPOWER (2R)	OPWR-HDEG (OTS)
APSC-IMP (OCN)	HI-TXPOWER (EQPT)	OPWR-LDEG (AOTS)
APSCDFLTK (OCN)	HI-TXPOWER (ESCON)	OPWR-LDEG (OCH-TERM)
APSCINCON (OCN)	HI-TXPOWER (FC)	OPWR-LDEG (OCH)
APSCM (OCN)	HI-TXPOWER (GE)	OPWR-LDEG (OMS)
APSIMP (OCN)	HI-TXPOWER (ISC)	OPWR-LDEG (OTS)
APSM (OCN)	HI-TXPOWER (OCN)	OTUK-IAE (TRUNK)
AUTORESET (EQPT)	HI-TXPOWER (PPM)	PROTNA (EQPT)
AWG-DEG (OTS)	HI-TXPOWER (TRUNK)	PROV-MISMATCH (PPM)
BPV (BITS)	HP-TIM (VCMON-HP)	PWR-FAIL-A (EQPT)
CASETEMP-DEG (AOTS)	IS-ADJ-FAIL (OCN)	PWR-FAIL-B (EQPT)
CONTBUS-IO-A (CONTBUS-A) (EQPT)	IS-ADJ-FAIL (TRUNK)	PWR-FAIL-RET-A (EQPT)
CONTBUS-IO-B (CONTBUS-B) (EQPT)	LASERBIAS-DEG (AOTS)	PWR-FAIL-RET-B (EQPT)
DATAFLT (NE)	LASERBIAS-DEG (OTS)	RS-EOC (STMN)
DCU-LOSS-FAIL (OTS)	LASERTEMP-DEG (AOTS)	SFTWDOWN (EQPT)
DUP-IPADDR (NE)	LMP-FAIL (GE)	SH-IL-VAR-DEG-HIGH (OTS)
DUP-NODENAME (NE)	LMP-SD (GE)	SH-IL-VAR-DEG-LOW (OTS)
EOC (OCN)	LMP-SF (GE)	SNTIP-HOST (NE)
EOC (TRUNK)	LOF (BITS)	SPANLEN-OUT-OF-RANGE (OTS)
EOC-L (OCN)	LO-LASERBIAS (EQPT)	SSM-FAIL (BITS)
EOC-L (TRUNK)	LO-LASERBIAS (OCN)	SSM-FAIL (TRUNK)
EXCCOL (EQPT)	LO-LASERBIAS (PPM)	SYNCPRI (EXT-SREF)
EXT (ENVALRM)	LO-LASERTEMP (EQPT)	SYNCSEC (EXT-SREF)
FAPS-CONFIG-MISMATCH (EQPT)	LO-LASERTEMP (OCN)	SYNCSEC (NE-SREF)
FEPRLF (OCN)	LO-LASERTEMP (PPM)	SYNCTHIRD (EXT-SREF)
FIBERTEMP-DEG (AOTS)	LO-RXPOWER (2R)	SYNCTHIRD (NE-SREF)
FP-LINK-LOSS (EQPT)	LO-RXPOWER (ESCON)	TIM-MON (TRUNK)
GAIN-HDEG (AOTS)	LO-RXPOWER (FC)	TIM-P (STSMON)
GAIN-LDEG (AOTS)	LO-RXPOWER (GE)	VOA-HDEG (AOTS)

Table 2-3 Minor DWDM Alarm List (continued)

GCC-EOC (TRUNK)	LO-RXPOWER (ISC)	VOA-HDEG (OCH)
HELLO (OCN)	LO-RXPOWER (OCN)	VOA-HDEG (OMS)
HELLO (TRUNK)	LO-RXPOWER (TRUNK)	VOA-HDEG (OTS)
HI-LASERBIAS (2R)	LOS (BITS)	VOA-LDEG (AOTS)
HI-LASERBIAS (EQPT)	LOS-O (OCH)	VOA-LDEG (OCH)
HI-LASERBIAS (ESCON)	LOS-O (OMS)	VOA-LDEG (OMS)
HI-LASERBIAS (FC)	LOS-O (OTS)	VOA-LDEG (OTS)
HI-LASERBIAS (GE)	LO-TXPOWER (2R)	—
HI-LASERBIAS (ISC)	LO-TXPOWER (EQPT)	—

2.1.4 NA Conditions

Table 2-4 alphabetically lists Not Alarmed (NA) DWDM conditions.

Table 2-4 NA DWDM Conditions List

APC-DISABLED (OCH)	FORCED-REQ-SPAN (ISC)	SD-L (TRUNK)
APC-DISABLED (OMS)	FORCED-REQ-SPAN (OCN)	SD-P (STSMON)
APC-DISABLED (OTS)	FORCED-REQ-SPAN (OTS)	SD-P (STSTRM)
APC-DISABLED (SHELF)	FORCED-REQ-SPAN (TRUNK)	SF (TRUNK)
APC-END (NE)	FRCDSWTOINT (NE-SREF)	SFBER-EXCEED-HO (VCMON-HP)
APC-WRONG-GAIN (AOTS)	FRNGSYNC (NE-SREF)	SFBER-EXCEED-HO (VCTRM-HP)
ALS (2R)	FRCDSWTOPRI (EXT-SREF)	SFBER-EXCEED-HO (VCTRM-LP)
ALS (AOTS)	FRCDSWTOPRI (NE-SREF)	SF-L (TRUNK)
ALS (ESCON)	FRCDSWTOSEC (EXT-SREF)	SF-P (STSMON)
ALS (FC)	FRCDSWTOSEC (NE-SREF)	SF-P (STSTRM)
ALS (GE)	FRCDSWTOTHIRD (EXT-SREF)	SHUTTER-OPEN (OTS)
ALS (ISC)	FRCDSWTOTHIRD (NE-SREF)	SPAN-NOT-MEASURED (OTS)
ALS (OCN)	FSTSYNC (NE-SREF)	SQUELCHED (2R)
ALS (TRUNK)	FTA-MISMATCH (EQPT)	SQUELCHED (ESCON)
ALS-DISABLED (EQPT)	HI-CCVOLT (BITS)	SQUELCHED (FC)
APC-DISABLED (AOTS)	HLDOVRSYNC (NE-SREF)	WKSWPR (FC)
APC-DISABLED (EQPT)	HP-DEG (VCMON-HP)	WKSWPR (GE)
APC-DISABLED (NE)	HP-DEG (VCTRM-HP)	WKSWPR (ISC)
APS-PRIM-FAC (OCN)	HP-EXC (VCMON-HP)	WKSWPR (OTS)
AS-CMD (2R)	HP-EXC (VCTRM-HP)	WTR (2R)

Table 2-4 NA DWDM Conditions List (continued)

AS-CMD (AOTS)	INHSWPR (EQPT)	WTR (EQPT)
AS-CMD (BPLANE)	INHSWWKG (EQPT)	WTR (ESCON)
AS-CMD (EQPT)	INTRUSION-PSWD (NE)	WTR (FC)
AS-CMD (ESCON)	LAN-POL-REV (NE)	WTR (GE)
AS-CMD (FC)	LASER-APR (AOTS)	WTR (ISC)
AS-CMD (GE)	LASER-APR (OTS)	WTR (TRUNK)
AS-CMD (ISC)	LMP-UNALLOC (GE)	SSM-LNC (BITS)
AS-CMD (NE)	LOCKOUT-REQ (2R)	SSM-LNC (NE-SREF)
AS-CMD (OCH)	LOCKOUT-REQ (EQPT)	SSM-LNC (TRUNK)
AS-CMD (OCN)	LOCKOUT-REQ (ESCON)	SSM-OFF (BITS)
AS-CMD (OMS)	LOCKOUT-REQ (FC)	SSM-OFF (TRUNK)
AS-CMD (OTS)	LOCKOUT-REQ (GE)	SSM-PRC (BITS)
AS-CMD (PPM)	LOCKOUT-REQ (ISC)	SQUELCHED (GE)
AS-CMD (PWR)	LOCKOUT-REQ (OCN)	SQUELCHED (ISC)
AS-CMD (SHELF)	LOCKOUT-REQ (OTS)	SQUELCHED (OCN)
AS-CMD (TRUNK)	LOCKOUT-REQ (STSMON)	SQUELCHED (TRUNK)
AS-MT (2R)	LOCKOUT-REQ (TRUNK)	SSM-DUS (BITS)
AS-MT (AOTS)	LPBKCRS (STSMON)	SSM-DUS (TRUNK)
AS-MT (EQPT)	LPBKFACILITY (ESCON)	SSM-PRC (NE-SREF)
AS-MT (ESCON)	LPBKFACILITY (FC)	SSM-PRC (TRUNK)
AS-MT (FC)	LPBKFACILITY (GE)	SSM-PRS (BITS)
AS-MT (GE)	LPBKFACILITY (ISC)	SSM-PRS (NE-SREF)
AS-MT (ISC)	LPBKFACILITY (TRUNK)	SSM-PRS (TRUNK)
AS-MT (OCH)	LPBKTERMINAL (ESCON)	SSM-RES (BITS)
AS-MT (OCN)	LPBKTERMINAL (FC)	SSM-RES (NE-SREF)
AS-MT (OMS)	LPBKTERMINAL (GE)	SSM-RES (TRUNK)
AS-MT (OTS)	LPBKTERMINAL (ISC)	SSM-SDH-TN (BITS)
AS-MT (PPM)	LPBKTERMINAL (TRUNK)	SSM-SDH-TN (NE-SREF)
AS-MT (SHELF)	MAN-REQ (EQPT)	SSM-SDH-TN (TRUNK)
AS-MT (TRUNK)	MANRESET (EQPT)	SSM-SETS (BITS)
AS-MT-OOG (STSTRM)	MANSWTOINT (NE-SREF)	SSM-SETS (NE-SREF)
AUD-LOG-LOSS (NE)	MANSWTOPRI (EXT-SREF)	SSM-SETS (TRUNK)
AUD-LOG-LOW (NE)	MANSWTOPRI (NE-SREF)	SSM-SMC (BITS)
AUTOSW-LOP (STSMON)	MANSWTOSEC (EXT-SREF)	SSM-SMC (NE-SREF)
AUTOSW-LOP-SNCP (VCMON-HP)	MANSWTOSEC (NE-SREF)	SSM-SMC (TRUNK)
AUTOSW-LOP-SNCP (VCMON-LP)	MANSWTOHIRD (EXT-SREF)	SSM-ST2 (BITS)
AUTOSW-PDI-SNCP (VCMON-HP)	MANSWTOHIRD (NE-SREF)	SSM-ST2 (NE-SREF)

Table 2-4 NA DWDM Conditions List (continued)

AUTOSW-PDI (STSMON)	MANUAL-REQ-SPAN (2R)	SSM-ST2 (TRUNK)
AUTOSW-SDBER (STSMON)	MANUAL-REQ-SPAN (ESCON)	SSM-ST3 (BITS)
AUTOSW-SFBER (STSMON)	MANUAL-REQ-SPAN (FC)	SSM-ST3 (NE-SREF)
AUTOSW-SDBER-SNCP (VCMON-HP)	MANUAL-REQ-SPAN (GE)	SSM-ST3 (TRUNK)
AUTOSW-SFBER-SNCP (STSMON)	MANUAL-REQ-SPAN (ISC)	SSM-ST3E (BITS)
AUTOSW-UNEQ (STSMON)	MANUAL-REQ-SPAN (OCN)	SSM-ST3E (NE-SREF)
AUTOSW-UNEQ-SNCP (VCMON-HP)	MANUAL-REQ-SPAN (OTS)	SSM-ST3E (TRUNK)
AUTOSW-UNEQ-SNCP (VCMON-LP)	MANUAL-REQ-SPAN (TRUNK)	SSM-ST4 (BITS)
AWG-WARM-UP (OTS)	MS-DEG (STM1E)	SSM-ST4 (NE-SREF)
CHANLOSS (OCN)	MS-DEG (STMN)	SSM-ST4 (TRUNK)
CLDRESTART (EQPT)	MS-EOC (STMN)	SSM-STU (BITS)
CTNEQPT-MISMATCH (EQPT)	MS-EXC (STM1E)	SSM-STU (NE-SREF)
ETH-LINKLOSS (NE)	MS-EXC (STMN)	SSM-STU (TRUNK)
FAILTOSW (2R)	MT-OCHNC (OTS)	SSM-TNC (BITS)
FAILTOSW (EQPT)	OCHNC-INC (OCHNC-CONN)	SSM-TNC (NE-SREF)
FAILTOSW (ESCON)	OCHTERM-INC (OCH-TERM)	SSM-TNC (TRUNK)
FAILTOSW (GE)	ODUK-SD-PM (TRUNK)	SW-MISMATCH (EQPT)
FAILTOSW (FC)	ODUK-SF-PM (TRUNK)	SWTOPRI (EXT-SREF)
FAILTOSW (ISC)	OPEN-SLOT (EQPT)	SWTOPRI (NE-SREF)
FAILTOSW (OCN)	OSRION (AOTS)	SWTOSEC (EXT-SREF)
FAILTOSW (OTS)	OSRION (OTS)	SWTOSEC (NE-SREF)
FAILTOSW (TRUNK)	OTUK-SD (TRUNK)	SWTOTHIRD (EXT-SREF)
FAILTOSW-HO (VCMON-HP)	OTUK-SF (TRUNK)	TRAIL-SIGNAL-FAIL (OCH)
FAILTOSW-PATH (STSMON)	OUT-OF-SYNC (ISC)	SWTOTHIRD (NE-SREF)
FAPS (TRUNK)	PARAM-MISM (AOTS)	SYNC-FREQ (BITS)
FDI (OCH-TERM)	PARAM-MISM (OCH)	SYNC-FREQ (TRUNK)
FDI (OCH)	PARAM-MISM (OCH-TERM)	TEMP-MISM (NE)
FE-FRCDWKSWBK-SPAN (OCN)	PARAM-MISM (OMS)	TRAIL-SIGNAL-FAIL (TRUNK)
FORCED-REQ (STSMON)	PARAM-MISM (OTS)	UNC-WORD (TRUNK)
FE-FRCDWKSWPR-SPAN (OCN)	PDI-P (STSMON)	VOLT-MISM (PWR)
FE-MANWKSWBK-SPAN (OCN)	PDI-P (STSTRM)	WKSWPR (2R)
FE-MANWKSWPR-SPAN (OCN)	PMI (OMS)	WKSWPR (EQPT)
FORCED-REQ (EQPT)	PMI (OTS)	WKSWPR (ESCON)
FORCED-REQ (POS)	RLS (OTS)	WKSWPR (FC)
FORCED-REQ-SPAN (2R)	RUNCFG-SAVENEED (EQPT)	WKSWPR (GE)
FORCED-REQ-SPAN (ESCON)	SD (TRUNK)	WKSWPR (ISC)

Table 2-4 NA DWDM Conditions List (continued)

FORCED-REQ-SPAN (FC)	SD-L (OCN)	WKSWPR (OTS)
FORCED-REQ-SPAN (GE)	SD-L (OCN)	—

2.1.5 NR Conditions

Table 2-5 alphabetically lists Not Reported (NR) DWDM conditions.

Table 2-5 NR DWDM Conditions List

AIS (BITS)	ERFI-P-CONN (STSTRM)	ODUK-AIS-PM (TRUNK)
AIS (TRUNK)	ERFI-P-SRVR (STSMON)	ODUK-BDI-PM (TRUNK)
AIS-L (OCN)	ERFI-P-SRVR (STSTRM)	ODUK-LCK-PM (TRUNK)
AIS-L (TRUNK)	HP-RFI (VCMON-HP)	ODUK-OCI-PM (TRUNK)
AIS-P (STSMON)	MS-AIS (STMN)	OTUK-AIS (TRUNK)
AIS-P (STSTRM)	MS-AIS (STM1E)	OTUK-BDI (TRUNK)
AU-AIS (VCTRM-HP)	MS-RFI (STMN)	RFI (TRUNK)
AU-AIS (VCMON-HP)	MS-RFI (STM1E)	RFI-L (OCN)
AUTOSW-AIS (STSMON)	ODUK-1-AIS-PM (TRUNK)	RFI-L (TRUNK)
AUTOSW-AIS-SNCP (VCMON-HP)	ODUK-2-AIS-PM (TRUNK)	RFI-P (STSMON)
AUTOSW-AIS-SNCP (VCMON-LP)	ODUK-3-AIS-PM (TRUNK)	RFI-P (STSTRM)
ERFI-P-CONN (STSMON)	ODUK-4-AIS-PM (TRUNK)	UNQUAL-PPM

2.1.6 Alarms and Conditions Listed By Alphabetical Entry

Table 2-6 alphabetically lists all DWDM alarms and conditions.

Table 2-6 Alphabetical DWDM Alarm and Condition List

—	GFP-CSF (CE1000)	ODUK-TIM-PM (TRUNK)
—	GFP-CSF (CEMR)	OPEN-SLOT (EQPT)
—	GFP-CSF (FCMR)	OPWR-HDEG (AOTS)
—	GFP-CSF (GFP-FAC)	OPWR-HDEG (OCH)
AIS (BITS)	GFP-CSF (ML100T)	OPWR-HDEG (OCH-TERM)
AIS (TRUNK)	GFP-CSF (ML1000)	OPWR-HDEG (OMS)
AIS-L (OCN)	GFP-CSF (MLMR)	OPWR-HDEG (OTS)
AIS-L (TRUNK)	GFP-LFD (CE100T)	OPWR-HFAIL (AOTS)
AIS-P (STSMON)	GFP-LFD (CE1000)	OPWR-HFAIL (OCH)
AIS-P (STSTRM)	GFP-LFD (CEMR)	OPWR-HFAIL (OMS)
ALS (2R)	GFP-LFD (FCMR)	OPWR-HFAIL (OTS)
ALS (AOTS)	GFP-LFD (GFP-FAC)	OPWR-LDEG (AOTS)

Table 2-6 Alphabetical DWDM Alarm and Condition List (continued)

ALS (ESCON)	GFP-LFD (ML100T)	OPWR-LDEG (OCH)
ALS (FC)	GFP-LFD (ML1000)	OPWR-LDEG (OCH-TERM)
ALS (GE)	GFP-LFD (MLMR)	OPWR-LDEG (OMS)
ALS (ISC)	GFP-LFD (POS)	OPWR-LDEG (OTS)
ALS (OCN)	GFP-UP-MISMATCH (CE100T)	OPWR-LFAIL (AOTS)
ALS (TRUNK)	GFP-UP-MISMATCH (CE1000)	OPWR-LFAIL (OCH)
ALS-DISABLED (EQPT)	GFP-UP-MISMATCH (CEMR)	OPWR-LFAIL (OCH-TERM)
AMPLI-INIT (AOTS)	GFP-UP-MISMATCH (FCMR)	OPWR-LFAIL (OMS)
APC-CORR-SKIPPED (AOTS)	GFP-UP-MISMATCH (GFP-FAC)	OPWR-LFAIL (OTS)
APC-CORR-SKIPPED (OCH)	GFP-UP-MISMATCH (ML100T)	OSRION (AOTS)
APC-CORR-SKIPPED (OMS)	GFP-UP-MISMATCH (ML1000)	OSRION (OTS)
APC-CORR-SKIPPED (OTS)	GFP-UP-MISMATCH (MLMR)	OTUK-AIS (TRUNK)
APC-DISABLED (AOTS)	GFP-UP-MISMATCH (POS)	OTUK-BDI (TRUNK)
APC-DISABLED (EQPT)	HELLO (TRUNK)	OTUK-IAE (TRUNK)
APC-DISABLED (NE)	HIBATVG (PWR)	OTUK-LOF (TRUNK)
APC-DISABLED (OCH)	HI-CCVOLT (BITS)	OTUK-SD (TRUNK)
APC-DISABLED (OMS)	HI-LASERBIAS (2R)	OTUK-SF (TRUNK)
APC-DISABLED (OTS)	HI-LASERBIAS (EQPT)	OTUK-TIM (TRUNK)
APC-DISABLED (SHELF)	HI-LASERBIAS (ESCON)	OUT-OF-SYNC (FC)
APC-END (NE)	HI-LASERBIAS (FC)	OUT-OF-SYNC (GE)
APC-OUT-OF-RANGE (AOTS)	HI-LASERBIAS (GE)	OUT-OF-SYNC (ISC)
APC-OUT-OF-RANGE (OCH)	HI-LASERBIAS (ISC)	OUT-OF-SYNC (TRUNK)
APC-OUT-OF-RANGE (OMS)	HI-LASERBIAS (OCN)	PARAM-MISM (AOTS)
APC-OUT-OF-RANGE (OTS)	HI-LASERBIAS (PPM)	PARAM-MISM (OCH)
APC-WRONG-GAIN (AOTS)	HI-LASERBIAS (TRUNK)	PARAM-MISM (OCH-TERM)
APS-INV-PRIM (OCN)	HI-LASERTEMP (EQPT)	PARAM-MISM (OMS)
APS-PRIM-FAC (OCN)	HI-LASERTEMP (OCN)	PARAM-MISM (OTS)
APS-PRIM-SEC-MISM (OCN)	HI-LASERTEMP (PPM)	PDI-P (STSMON)
APSB (OCN)	HI-RXPOWER (2R)	PDI-P (STSTRM)
APSC-IMP (OCN)	HI-RXPOWER (ESCON)	PEER-NORESPONSE (EQPT)
APSCDFLTK (OCN)	HI-RXPOWER (FC)	PM-TCA
APSCINCON (OCN)	HI-RXPOWER (GE)	PMI (OMS)
APSCM (OCN)	HI-RXPOWER (ISC)	PMI (OTS)
APSCNMIS (OCN)	HI-RXPOWER (OCN)	PORT-FAIL (OCH)
APSIMP (OCN)	HI-RXPOWER (TRUNK)	PROTNA (EQPT)
APSMM (OCN)	HITEMP (EQPT)	PROV-MISMATCH (PPM)
AS-CMD (2R)	HITEMP (NE)	PROV-MISMATCH (TRUNK)

Table 2-6 Alphabetical DWDM Alarm and Condition List (continued)

AS-CMD (AOTS)	HI-TXPOWER (2R)	PTIM (TRUNK)
AS-CMD (BPLANE)	HI-TXPOWER (EQPT)	PWR-FAIL-A (EQPT)
AS-CMD (EQPT)	HI-TXPOWER (ESCON)	PWR-FAIL-B (EQPT)
AS-CMD (ESCON)	HI-TXPOWER (FC)	PWR-FAIL-RET-A (EQPT)
AS-CMD (FC)	HI-TXPOWER (GE)	PWR-FAIL-RET-B (EQPT)
AS-CMD (GE)	HI-TXPOWER (ISC)	PWR-PROT-ON (OTS)
AS-CMD (ISC)	HI-TXPOWER (OCN)	RFI (TRUNK)
AS-CMD (NE)	HI-TXPOWER (PPM)	RFI-L (OCN)
AS-CMD (OCH)	HI-TXPOWER (TRUNK)	RFI-P (STSMON)
AS-CMD (OCN)	HLDOVRSYNC (NE-SREF)	RFI-P (STSTRM)
AS-CMD (OMS)	HP-DEG (VCMON-HP)	RLS (OTS)
AS-CMD (OTS)	HP-DEG (VCTRM-HP)	RMON-ALARM
AS-CMD (PPM)	HP-ENCAP-MISMATCH (VCTRM-HP)	RMON-RESET
AS-CMD (PWR)	HP-EXC (VCMON-HP)	RING-ID-MIS (OSC-RING)
AS-CMD (SHELF)	HP-EXC (VCTRM-HP)	RS-EOC (STMN)
AS-CMD (TRUNK)	HP-PLM (VCMON-HP)	RS-TIM (STMN)
AS-MT-OOG (STSTRM)	HP-PLM (VCTRM-HP)	RUNCFG-SAVENEED (EQPT)
AS-MT (2R)	HP-RFI (VCMON-HP)	SD (TRUNK)
AS-MT (AOTS)	HP-TIM (VCMON-HP)	SD-L (OCN)
AS-MT (EQPT)	HP-UNEQ (VCMON-HP)	SD-P (STSMON)
AS-MT (ESCON)	HP-UNEQ (VCTRM-HP)	SD-P (STSTRM)
AS-MT (FC)	I-HITEMP (NE)	SF (TRUNK)
AS-MT (GE)	ILK-FAIL (TRUNK)	SF-L (TRUNK)
AS-MT (ISC)	IMPROPRMVL (EQPT)	SF-P (STSMON)
AS-MT (OCH)	IMPROPRMVL (PPM)	SF-P (STSTRM)
AS-MT (OCN)	INTRUSION-PSWD (NE)	SFBER-EXCEED-HO (VCMON-HP)
AS-MT (OMS)	INVMACADR (AIP)	SFBER-EXCEED-HO (VCTRM-HP)
AS-MT (OTS)	INHSWPR (EQPT)	SFBER-EXCEED-HO (VCTRM-LP)
AS-MT (PPM)	INHSWWKG (EQPT)	SFTWDOWN (EQPT)
AS-MT (SHELF)	ISIS-ADJ-FAIL (OCN)	SHELF-COMM-FAIL (SHELF)
AS-MT (TRUNK)	ISIS-ADJ-FAIL (TRUNK)	SH-IL-VAR-DEG-HIGH (OTS)
AU-AIS (VCTRM-HP)	LAN-POL-REV (NE)	SH-IL-VAR-DEG-LOW (OTS)
AU-AIS (VCMON-HP)	LASEREOL (OCN)	SHUTTER-OPEN (OTS)
AU-LOP (VCTRM-HP)	LASER-APR (AOTS)	SIGLOSS (ESCON)
AU-LOP (VCMON-HP)	LASER-APR (OTS)	SIGLOSS (FC)
AUD-LOG-LOSS (NE)	LASERBIAS-DEG (AOTS)	SIGLOSS (GE)
AUD-LOG-LOW (NE)	LASERBIAS-DEG (OTS)	SIGLOSS (ISC)

Table 2-6 Alphabetical DWDM Alarm and Condition List (continued)

AUTORESET (EQPT)	LASERBIAS-FAIL (AOTS)	SIGLOSS (TRUNK)
AUTOLSROFF (OCN)	LASERTEMP-DEG (AOTS)	SNTP-HOST (NE)
AUTOSW-AIS (STSMON)	LMP-FAIL (GE)	SPANLEN-OUT-OF-RANGE (OTS)
AUTOSW-AIS-SNCP (VCMON-HP)	LMP-SD (GE)	SPAN-NOT-MEASURED (OTS)
AUTOSW-AIS-SNCP (VCMON-LP)	LMP-SF (GE)	SQUELCHED (2R)
AUTOSW-LOP (STSMON)	LMP-UNALLOC (GE)	SQUELCHED (ESCON)
AUTOSW-LOP-SNCP (VCMON-HP)	LOCKOUT-REQ (2R)	SQUELCHED (FC)
AUTOSW-LOP-SNCP (VCMON-LP)	LOCKOUT-REQ (EQPT)	SQUELCHED (GE)
AUTOSW-PDI (STSMON)	LOCKOUT-REQ (ESCON)	SQUELCHED (ISC)
AUTOSW-PDI-SNCP (VCMON-HP)	LOCKOUT-REQ (FC)	SQUELCHED (OCN)
AUTOSW-SDBER (STSMON)	LOCKOUT-REQ (GE)	SQUELCHED (TRUNK)
AUTOSW-SDBER-SNCP (VCMON-HP)	LOCKOUT-REQ (ISC)	SSM-DUS (BITS)
AUTOSW-SFBER (STSMON)	LOCKOUT-REQ (OTS)	SSM-DUS (TRUNK)
AUTOSW-SFBER-SNCP (STSMON)	LOCKOUT-REQ (TRUNK)	SSM-FAIL (BITS)
AUTOSW-UNEQ (STSMON)	LOF (BITS)	SSM-FAIL (TRUNK)
AUTOSW-UNEQ-SNCP (VCMON-HP)	LOF (TRUNK)	SSM-LNC (BITS)
AUTOSW-UNEQ-SNCP (VCMON-LP)	LO-LASERBIAS (EQPT)	SSM-LNC (NE-SREF)
AWG-DEG (OTS)	LO-LASERBIAS (OCN)	SSM-LNC (TRUNK)
AWG-FAIL (OTS)	LO-LASERBIAS (PPM)	SSM-OFF (BITS)
AWG-OVERTEMP (OTS)	LO-LASERTEMP (EQPT)	SSM-OFF (TRUNK)
AWG-WARM-UP (OTS)	LO-LASERTEMP (OCN)	SSM-PRC (BITS)
BAT-FAIL (PWR)	LO-LASERTEMP (PPM)	SSM-PRC (NE-SREF)
BKUPMEMP (EQPT)	LOM (TRUNK)	SSM-PRC (TRUNK)
BPV (BITS)	LOP-P (TRUNK)	SSM-PRS (BITS)
CARLOSS (EQPT)	LOP-P (OCH)	SSM-PRS (NE-SREF)
CARLOSS (FC)	LOP-P (OMS)	SSM-PRS (TRUNK)
CARLOSS (GE)	LOP-P (OTS)	SSM-RES (BITS)
CARLOSS (ISC)	LO-RXPOWER (2R)	SSM-RES (NE-SREF)
CARLOSS (TRUNK)	LO-RXPOWER (ESCON)	SSM-RES (TRUNK)
CASETEMP-DEG (AOTS)	LO-RXPOWER (FC)	SSM-SDH-TN (BITS)
CHANLOSS (OCN)	LO-RXPOWER (GE)	SSM-SDH-TN (NE-SREF)
CLDRESTART (EQPT)	LO-RXPOWER (ISC)	SSM-SDH-TN (TRUNK)
CONTBUS-DISABLED (EQPT)	LO-RXPOWER (OCN)	SSM-SETS (BITS)
CONTBUS-IO-A (CONTBUS-A) (EQPT)	LO-RXPOWER (TRUNK)	SSM-SETS (NE-SREF)
CONTBUS-IO-B (CONTBUS-B) (EQPT)	LOS (2R)	SSM-SETS (TRUNK)
CTNEQPT-MISMATCH (EQPT)	LOS (BITS)	SSM-SMC (BITS)

Table 2-6 Alphabetical DWDM Alarm and Condition List (continued)

DATAFLT (NE)	LOS (ESCON)	SSM-SMC (NE-SREF)
DBOSYNC (NE)	LOS (ISC)	SSM-SMC (TRUNK)
DCU-LOSS-FAIL (OTS)	LOS (OTS)	SSM-ST2 (BITS)
DSP-COMM-FAIL (TRUNK)	LOS (TRUNK)	SSM-ST2 (NE-SREF)
DSP-FAIL (TRUNK)	LOS-O (OCH)	SSM-ST2 (TRUNK)
DUP-IPADDR (NE)	LOS-O (OMS)	SSM-ST3 (BITS)
DUP-NODENAME (NE)	LOS-O (OTS)	SSM-ST3 (NE-SREF)
DUP-SHELF-ID (SHELF)	LOS-P (OCH)	SSM-ST3 (TRUNK)
EHIBATVG (PWR)	LOS-P (OMS)	SSM-ST3E (BITS)
ELWBATVG (PWR)	LOS-P (OTS)	SSM-ST3E (NE-SREF)
ENCAP-MISMATCH-P (STSTRM)	LOS-P (TRUNK)	SSM-ST3E (TRUNK)
ENCAP-MISMATCH-P (POS)	LOS-RAMAN (OTS)	SSM-ST4 (BITS)
EOC (OCN)	LO-TXPOWER (2R)	SSM-ST4 (NE-SREF)
EOC (TRUNK)	LO-TXPOWER (EQPT)	SSM-ST4 (TRUNK)
EOC-L (OCN)	LO-TXPOWER (ESCON)	SSM-STU (BITS)
EOC-L (TRUNK)	LO-TXPOWER (FC)	SSM-STU (NE-SREF)
ERFI-P-CONN (STSMON)	LO-TXPOWER (GE)	SSM-STU (TRUNK)
ERFI-P-CONN (STSTRM)	LO-TXPOWER (ISC)	SSM-TNC (BITS)
ERFI-P-SRVR (STSMON)	LO-TXPOWER (OCN)	SSM-TNC (NE-SREF)
ERFI-P-SRVR (STSTRM)	LO-TXPOWER (PPM)	SSM-TNC (TRUNK)
EQPT (AICI-AEP)	LO-TXPOWER (TRUNK)	SW-MISMATCH (EQPT)
EQPT (AICI-AIE)	LPBKCRS (STSMON)	SWTOPRI (EXT-SREF)
EQPT (EQPT)	LPBKFACILITY (ESCON)	SWTOPRI (NE-SREF)
EQPT (PPM)	LPBKFACILITY (FC)	SWTOSEC (EXT-SREF)
EQPT-DIAG (EQPT)	LPBKFACILITY (GE)	SWTOSEC (NE-SREF)
EQPT-MISS (FAN)	LPBKFACILITY (ISC)	SWTOTHIRD (EXT-SREF)
ETH-LINKLOSS (NE)	LPBKFACILITY (TRUNK)	SWTOTHIRD (NE-SREF)
EXCCOL (EQPT)	LPBKTERMINAL (ESCON)	SYNC-FREQ (BITS)
EXT (ENVALRM)	LPBKTERMINAL (FC)	SYNC-FREQ (TRUNK)
FAILTOSW (2R)	LPBKTERMINAL (GE)	SYNCLOSS (FC)
FAILTOSW (EQPT)	LPBKTERMINAL (ISC)	SYNCLOSS (GE)
FAILTOSW (ESCON)	LPBKTERMINAL (TRUNK)	SYNCLOSS (ISC)
FAILTOSW (FC)	LWBATVG (PWR)	SYNCLOSS (TRUNK)
FAILTOSW (GE)	MAN-REQ (EQPT)	SYNCPRI (EXT-SREF)
FAILTOSW (ISC)	MANRESET (EQPT)	SYNCPRI (NE-SREF)
FAILTOSW (OCN)	MANSWTOINT (NE-SREF)	SYNCSEC (EXT-SREF)
FAILTOSW (OTS)	MANSWTOPRI (EXT-SREF)	SYNCSEC (NE-SREF)

Table 2-6 *Alphabetical DWDM Alarm and Condition List (continued)*

FAILTOSW (TRUNK)	MANSWTOPRI (NE-SREF)	SYNCTHIRD (EXT-SREF)
FAILTOSW-HO (STSMON)	MANSWTOSEC (EXT-SREF)	SYNCTHIRD (NE-SREF)
FAILTOSW-PATH (STSMON)	MANSWTOSEC (NE-SREF)	SYSBOOT (NE)
FAN (FAN)	MANSWTOTHIRD (EXT-SREF)	TEMP-MISM (NE)
FAPS (TRUNK)	MANSWTOTHIRD (NE-SREF)	TIM (TRUNK)
FAPS-CONFIG-MISMATCH (EQPT)	MANUAL-REQ-SPAN (2R)	TIM-MON (TRUNK)
FC-NO-CREDITS (FC)	MANUAL-REQ-SPAN (ESCON)	TIM-P (TRUNK)
FC-NO-CREDITS (TRUNK)	MANUAL-REQ-SPAN (FC)	TIM-S (TRUNK)
FDI (OCH)	MANUAL-REQ-SPAN (GE)	TRAIL-SIGNAL-FAIL (OCH)
FDI (OCH-TERM)	MANUAL-REQ-SPAN (ISC)	TRAIL-SIGNAL-FAIL (TRUNK)
FE-FRCDWKSWBK-SPAN (OCN)	MANUAL-REQ-SPAN (OCN)	UNC-WORD (TRUNK)
FE-FRCDWKSWPR-SPAN (OCN)	MANUAL-REQ-SPAN (OTS)	UNEQ-P (STSMON, STSTRM)
FE-MANWKSWBK-SPAN (OCN)	MANUAL-REQ-SPAN (TRUNK)	UNQUAL-PPM (PPM)
FE-MANWKSWPR-SPAN (OCN)	MANWKSWBK-NO-TRFSW (OCN)	UT-COMM-FAIL (TRUNK)
FEC-MISM (TRUNK)	MANWKSWPR-NO-TRFSW (OCN)	UT-FAIL (TRUNK)
FEPRLF (OCN)	MEA (AIP)	VOA-DISABLED (EQPT)
FIBERTEMP-DEG (AOTS)	MEA (EQPT)	VOA-HDEG (AOTS)
FORCED-REQ (EQPT)	MEA (FAN)	VOA-HDEG (OCH)
FORCED-REQ (STSMON)	MEA (PPM)	VOA-HDEG (OMS)
FORCED-REQ (POS)	MEA (SHELF)	VOA-HDEG (OTS)
FORCED-REQ-SPAN (2R)	MEM-GONE (EQPT)	VOA-HFAIL (AOTS)
FORCED-REQ-SPAN (ESCON)	MEM-LOW (EQPT)	VOA-HFAIL (OCH)
FORCED-REQ-SPAN (FC)	MFGMEM (AICI-AEP)	VOA-HFAIL (OMS)
FORCED-REQ-SPAN (GE)	MFGMEM (AICI-AIE)	VOA-HFAIL (OTS)
FORCED-REQ-SPAN (ISC)	MFGMEM (AIP)	VOA-LDEG (AOTS)
FORCED-REQ-SPAN (OCN)	MFGMEM (BPLANE)	VOA-LDEG (OCH)
FORCED-REQ-SPAN (OTS)	MFGMEM (FAN)	VOA-LDEG (OMS)
FORCED-REQ-SPAN (TRUNK)	MFGMEM (PPM)	VOA-LDEG (OTS)
FP-LINK-LOSS (EQPT)	MS-AIS (STMN)	VOA-LFAIL (AOTS)
FRCDSWTOINT (NE-SREF)	MS-AIS (STM1E)	VOA-LFAIL (OCH)
FRCDSWTOPRI (EXT-SREF)	MS-DEG (STMN)	VOA-LFAIL (OMS)
FRCDSWTOPRI (NE-SREF)	MS-DEG (STM1E)	VOA-LFAIL (OTS)
FRCDSWTOSEC (EXT-SREF)	MS-EOC (STMN)	VOLT-MISM (PWR)
FRCDSWTOSEC (NE-SREF)	MS-EXC (STMN)	WKSWBK (EQPT)
FRCDSWTOTHIRD (EXT-SREF)	MS-EXC (STM1E)	WKSWBK (OCN)
FRCDSWTOTHIRD (NE-SREF)	MS-RFI (STMN)	WKSWBK (OTS)
FRCDWKSWBK-NO-TRFSW (OCN)	MS-RFI (STM1E)	WKSWPR (2R)

Table 2-6 Alphabetical DWDM Alarm and Condition List (continued)

FRCDWKSWPR-NO-TRFSW (OCN)	MT-OCHNC (OTS)	WKSWPR (EQPT)
FRNGSYNC (NE-SREF)	NON-CISCO-PPM (PPM)	WKSWPR (ESCON)
FSTSYNC (NE-SREF)	OCHNC-INC (OCHNC-CONN)	WKSWPR (FC)
FTA-MISMATCH (EQPT)	OCHTERM-INC (OCH-TERM)	WKSWPR (GE)
GAIN-HDEG (AOTS)	ODUK-1-AIS-PM (TRUNK)	WKSWPR (ISC)
GAIN-HFAIL (AOTS)	ODUK-2-AIS-PM (TRUNK)	WKSWPR (OTS)
GAIN-LDEG (AOTS)	ODUK-3-AIS-PM (TRUNK)	WORK-QUEUE-FULL (EQPT)
GAIN-LFAIL (AOTS)	ODUK-4-AIS-PM (TRUNK)	WTR (2R)
GCC-EOC (TRUNK)	ODUK-AIS-PM (TRUNK)	WTR (EQPT)
GE-OOSYNC (FC)	ODUK-BDI-PM (TRUNK)	WTR (ESCON)
GE-OOSYNC (GE)	ODUK-LCK-PM (TRUNK)	WTR (FC)
GE-OOSYNC (ISC)	ODUK-OCI-PM (TRUNK)	WTR (GE)
GE-OOSYNC (TRUNK)	ODUK-SD-PM (TRUNK)	WTR (ISC)
GFP-CSF (CE100T)	ODUK-SF-PM (TRUNK)	WTR (TRUNK)

2.2 Logical Objects

The CTC alarm profile list organizes all alarms and conditions according to the logical objects they are raised against. These logical objects represent physical objects such as cards, logical objects such as circuits, or transport and signal monitoring entities such as the SONET or ITU-T G.709 optical overhead bits. One alarm can appear in multiple entries. It can be raised against multiple objects. For example, the loss of signal (LOS) alarm can be raised against the optical signal (OC-N) or the optical transport layer overhead (OTN) as well as other objects. Therefore, both OCN: LOS and OTN: LOS appear in the list (as well as the other objects).

Alarm profile list objects are defined in [Table 2-7](#).



Note

Alarm logical object names can appear as abbreviated versions of standard terms used in the system and the documentation. For example, the “OCN” logical object refers to the OC-N signal. Logical object names or industry-standard terms are used within the entries as appropriate.

2.2.1 Alarm Logical Objects

[Table 2-7](#) lists all logical alarm objects used in this chapter.

Table 2-7 Alarm Logical Object Type Definitions

Logical Object	Definition
2R	Reshape and retransmit (used for transponder [TXP] cards).
AICI-AEP	Alarm Interface Controller–International/alarm expansion panel. A combination term that refers to this platform’s AIC-I card.

Table 2-7 Alarm Logical Object Type Definitions (continued)

Logical Object	Definition
AICI-AIE	Alarm Interface Controller-International/Alarm Interface Extension. A combination term that refers to this platform's AIC-I card.
AIP	Alarm Interface Panel.
AOTS	Amplified optical transport section.
BITS	Building integrated timing supply incoming references (BITS-1, BITS-2).
BPLANE	The backplane.
ENVALRM	An environmental alarm port.
EQPT	A card, its physical objects, and its logical objects as they are located in any of the eight noncommon card slots. The EQPT object is used for alarms that refer to the card itself and all other objects on the card including ports, lines, synchronous transport signals (STS), and virtual tributaries (VT).
ESCON	Enterprise System Connection fiber optic technology, referring to the following TXP cards: TXP_MR_2.5G, TXPP_MR_2.5G, MXP_MR_2.5G, MXPP_MR_2.5G.
EXT-SREF	BITS outgoing references (SYNC-BITS1, SYNC-BITS2).
FAN	Fan-tray assembly.
FC	Fibre channel data transfer architecture, referring to the following muxponder (MXP) or TXP cards: MXP_MR_2.5G, MXPP_MR_2.5G, MXP_MR_10DME_C, MXP_MR_10DME_L, TXP_MR_2.5G, TXPP_MR_2.5G, TXP_MR_10E, TXP_MR_10E_C, TXP_MR_10E_L, GE_XP, 10GE_XP, ADM-10G, and OTU2_XP.
GE	Gigabit Ethernet, referring to the following MXP or TXP cards: MXP_MR_2.5G, MXPP_MR_2.5G, TXP_MR_2.5G, TXPP_MR_2.5G, TXP_MR_10G, TXP_MR_10E, TXP_MR_10E_C, TXP_MR_10E_L, MXP_MR_10DME_C, MXP_MR_10DME_L, GE-XP, 10GE-XP, ADM-10G, and OTU2_XP.
ISC	Inter-service channel, referring to TXPP_MR_2.5G or TXP_MR_2.5G cards.
NE	The entire network element.
NE-SREF	The timing status of the NE.
OCH	The optical channel, referring to dense wavelength division multiplexing (DWDM) cards.
OCH-TERM	The optical channel termination node, referring to DWDM cards. The network element reports alarms or conditions on ingress ports of the card. Alarms detected at the internal ports (TERM side) will be ingress mapped to the MON side. The alarm profile entities of OCH-TERM, if available, should be changed to the same severity as the customized severity for a specific OCH-TERM alarm.
OCHNC-CONN	The optical channel network connection, referring to DWDM cards.
OMS	Optical multiplex section.
OSC-RING	Optical service channel ring.
OTS	Optical transport section.
PPM	Pluggable port module (PPM, also called SFP), referring to MXP and TXP cards.

Table 2-7 Alarm Logical Object Type Definitions (continued)

Logical Object	Definition
PWR	Power equipment.
SHELF	The shelf assembly.
STSMON	STS alarm detection at the monitor point (upstream from the cross-connect). Note The network element reports alarms or conditions on ingress ports of the card. Alarms detected at the internal ports (TERM side) will be ingress mapped to the MON side. The alarm profile entities of STSMON, if available, should be changed to the same severity as the customized severity for a specific STS alarm.
STSTRM	STS alarm detection at termination (downstream from the cross-connect). Note The network element reports alarms or conditions on ingress ports of the card. Alarms detected at the internal ports (TERM side) will be ingress mapped to the MON side. The alarm profile entities of STSTRM, if available, should be changed to the same severity as the customized severity for a specific STS alarm.
TRUNK	The optical or DWDM card carrying the high-speed signal; referring to MXP or TXP cards.
VT-MON	VT1 alarm detection at the monitor point (upstream from the cross-connect). Note The network element reports alarms or conditions on ingress ports of the card. Alarms detected at the internal ports (TERM side) will be ingress mapped to the MON side. The alarm profile entities of VT-MON, if available, should be changed to the same severity as the customized severity for a specific VT alarm.

2.2.2 Alarm List by Logical Object Type

Table 2-8 lists all Release 8.5 DWDM alarms and logical objects as they are given in the system alarm profile. The list entries are organized by logical object name and then by alarm or condition name. Where appropriate, the alarm entries also contain troubleshooting procedures.



Note

In a mixed network containing different types of nodes (for example, ONS 15310-CL, ONS 15454, and ONS 15600), the initially displayed alarm list in the node view (single-shelf mode) or shelf view (multishelf mode) Provisioning > Alarm Profiles tabs > Alarm Profile Editor tab lists all conditions that are applicable to all nodes in the network. However, when you load the default severity profile from a node, only applicable alarms will display severity levels. Nonapplicable alarms can display “use default” or “unset.”



Note

In some cases this list does not follow alphabetical order, but it does reflect the order shown in CTC.

Table 2-8 Alarm List by Logical Object in Alarm Profile

2R: ALS (NA)	GE: SQUELCHED (NA)	POS: ENCAP-MISMATCH-P (CR)
2R: AS-CMD (NA)	GE: SYNCLOSS (MJ)	POS: FORCED-REQ (NA)
2R: AS-MT (NA)	GE: WKSWPR (NA)	POS: GFP-CSF (MJ)
2R: FAILTOSW (NA)	GE: WTR (NA)	POS: GFP-LFD (MJ)
2R: FORCED-REQ-SPAN (NA)	GFP-FAC: GFP-CSF (MJ)	PPM: AS-CMD (NA)
2R: HI-LASERBIAS (MN)	GFP-FAC: GFP-LFD (MJ)	PPM: AS-MT (NA)
2R: HI-RXPOWER (MN)	GFP-FAC: GFP-UP-MISMATCH (MJ)	PPM: EQPT (CR)
2R: HI-TXPOWER (MN)	ISC: ALS (NA)	PPM: HI-LASERBIAS (MN)
2R: LO-RXPOWER (MN)	ISC: AS-CMD (NA)	PPM: HI-LASERTEMP (MN)
2R: LO-TXPOWER (MN)	ISC: AS-MT (NA)	PPM: HI-TXPOWER (MN)
2R: LOCKOUT-REQ (NA)	ISC: CARLOSS (MJ)	PPM: IMPROPRMVL (CR)
2R: LOS (CR)	ISC: FAILTOSW (NA)	PPM: LO-LASERBIAS (MN)
2R: MANUAL-REQ-SPAN (NA)	ISC: FORCED-REQ-SPAN (NA)	PPM: LO-LASERTEMP (MN)
2R: SQUELCHED (NA)	ISC: GE-OOSYNC (CR)	PPM: LO-TXPOWER (MN)
2R: WKSWPR (NA)	ISC: HI-LASERBIAS (MN)	PPM: MEA (CR)
2R: WTR (NA)	ISC: HI-RXPOWER (MN)	PPM: MFGMEM (CR)
AICI-AEP: EQPT (CR)	ISC: HI-TXPOWER (MN)	PPM: NON-CISCO-PPM (MN)
AICI-AEP: MFGMEM (CR)	ISC: LO-RXPOWER (MN)	PPM: PROV-MISMATCH (MN)
AICI-AIE: EQPT (CR)	ISC: LO-TXPOWER (MN)	PPM: UNQUAL-PPM (NR)
AICI-AIE: MFGMEM (CR)	ISC: LOCKOUT-REQ (NA)	PWR: AS-CMD (NA)
AIP: INVMACADR (MJ)	ISC: LOS (CR)	PWR: BAT-FAIL (MJ)
AIP: MEA (CR)	ISC: LPBKFACILITY (NA)	PWR: EHBATVVG (MJ)
AIP: MFGMEM (CR)	ISC: LPBKTERMINAL (NA)	PWR: ELWBATVVG (MJ)
AOTS: ALS (NA)	ISC: MANUAL-REQ-SPAN (NA)	PWR: HIBATVVG (MJ)
AOTS: AMPLI-INIT (NA)	ISC: OUT-OF-SYNC (NA)	PWR: LWBATVVG (MJ)
AOTS: APC-CORR-SKIPPED (MN)	ISC: SIGLOSS (MJ)	PWR: VOLT-MISM (NA)
AOTS: APC-DISABLED (MN)	ISC: SQUELCHED (NA)	SHELF: APC-DISABLED (MN)
AOTS: APC-OUT-OF-RANGE (MN)	ISC: SYNCLOSS (MJ)	SHELF: AS-CMD (NA)
AOTS: APC-WRONG-GAIN (NA)	ISC: WKSWPR (NA)	SHELF: AS-MT (NA)
AOTS: AS-CMD (NA)	ISC: WTR (NA)	SHELF: DUP-SHELF-ID (MJ)
AOTS: AS-MT (NA)	ML100T: GFP-CSF (MJ)	SHELF: MEA (MJ)
AOTS: CASETEMP-DEG (MN)	ML100T: GFP-LFD (MJ)	SHELF: SHELF-COMM-FAIL (MJ)
AOTS: FIBERTEMP-DEG (MN)	ML100T: GFP-UP-MISMATCH (MJ)	STM1E: MS-AIS (NR)
AOTS: GAIN-HDEG (MN)	ML1000: GFP-CSF (MJ)	STM1E: MS-DEG (NA)
AOTS: GAIN-HFAIL (CR)	ML1000: GFP-LFD (MJ)	STM1E: MS-EXC (NA)
AOTS: GAIN-LDEG (MN)	ML1000: GFP-UP-MISMATCH (MJ)	STM1E: MS-RFI (NR)
AOTS: GAIN-LFAIL (CR)	MLMR: GFP-CSF (MJ)	STM1E: SD-L (NA)

Table 2-8 Alarm List by Logical Object in Alarm Profile (continued)

AOTS: LASER-APR (NA)	MLMR: GFP-LFD (MJ)	STM1E: SF-L (NA)
AOTS: LASERBIAS-DEG (MN)	MLMR: GFP-UP-MISMATCH (MJ)	STMN: APSB (MN)
AOTS: LASERBIAS-FAIL (MJ)	NE-SREF: FRCDSWTOINT (NA)	STMN: APSC-IMP (MN)
AOTS: LASERTEMP-DEG (MN)	NE-SREF: FRCDSWTOPRI (NA)	STMN: APSCDFLTK (MN)
AOTS: OPWR-HDEG (MN)	NE-SREF: FRCDSWTOSEC (NA)	STMN: APSCINCON (MN)
AOTS: OPWR-HFAIL (CR)	NE-SREF: FRCDSWTOHTRD (NA)	STMN: APSCM (MN)
AOTS: OPWR-LDEG (MN)	NE-SREF: FRNGSYNC (NA)	STMN: APSCNMIS (MJ)
AOTS: OPWR-LFAIL (CR)	NE-SREF: FSTSYNC (NA)	STMN: APSMM (MN)
AOTS: OSRION (NA)	NE-SREF: HLDVRSYNC (NA)	STMN: AUTOLSROFF (CR)
AOTS: PARAM-MISM (NA)	NE-SREF: MANSWTOINT (NA)	STMN: FE-FRCDWKSWBK-SPAN (NA)
AOTS: VOA-HDEG (MN)	NE-SREF: MANSWTOPRI (NA)	STMN: FE-FRCDWKSWPR-SPAN (NA)
AOTS: VOA-HFAIL (CR)	NE-SREF: MANSWTOSEC (NA)	STMN: FE-MANWKSWBK-SPAN (NA)
AOTS: VOA-LDEG (MN)	NE-SREF: MANSWTOHTRD (NA)	STMN: FE-MANWKSWPR-SPAN (NA)
AOTS: VOA-LFAIL (CR)	NE-SREF: SSM-LNC (NA)	STMN: FEPRLF (MN)
BITS: AIS (NR)	NE-SREF: SSM-PRC (NA)	STMN: HELLO (MN)
BITS: BPV (MN)	NE-SREF: SSM-PRS (NA)	STMN: ISIS-ADJ-FAIL (MN)
BITS: HI-CCVOLT (NA)	NE-SREF: SSM-RES (NA)	STMN: LASEREOL (MN)
BITS: LOF (MN)	NE-SREF: SSM-SDH-TN (NA)	STMN: LOCKOUT-REQ (NA)
BITS: LOS (MN)	NE-SREF: SSM-SETS (NA)	STMN: MANWKSWBK-NO-TRFSW (NA)
BITS: SSM-DUS (NA)	NE-SREF: SSM-SMC (NA)	STMN: MANWKSWPR-NO-TRFSW (NA)
BITS: SSM-FAIL (MN)	NE-SREF: SSM-ST2 (NA)	STMN: MS-AIS (NR)
BITS: SSM-LNC (NA)	NE-SREF: SSM-ST3 (NA)	STMN: MS-DEG (NA)
BITS: SSM-OFF (NA)	NE-SREF: SSM-ST3E (NA)	STMN: MS-EOC (MN)
BITS: SSM-PRC (NA)	NE-SREF: SSM-ST4 (NA)	STMN: MS-EXC (NA)
BITS: SSM-PRS (NA)	NE-SREF: SSM-STU (NA)	STMN: MS-RFI (NR)
BITS: SSM-RES (NA)	NE-SREF: SSM-TNC (NA)	STMN: RS-EOC
BITS: SSM-SDH-TN (NA)	NE-SREF: SWTOPRI (NA)	STMN: RS-TIM
BITS: SSM-SETS (NA)	NE-SREF: SWTOSEC (NA)	STSMON: AIS-P (NR)
BITS: SSM-SMC (NA)	NE-SREF: SWTOHTRD (NA)	STSMON: AUTOSW-AIS (NR)
BITS: SSM-ST2 (NA)	NE-SREF: SYNCPRI (MJ)	STSMON: AUTOSW-LOP (NA)
BITS: SSM-ST3 (NA)	NE-SREF: SYNCSEC (MN)	STSMON: AUTOSW-PDI (NA)
BITS: SSM-ST3E (NA)	NE-SREF: SYNCHTRD (MN)	STSMON: AUTOSW-SDBER (NA)
BITS: SSM-ST4 (NA)	NE: APC-DISABLED (MN)	STSMON: AUTOSW-SFBER (NA)

Table 2-8 Alarm List by Logical Object in Alarm Profile (continued)

BITS: SSM-STU (NA)	NE: APC-END (NA)	STSMON: AUTOSW-UNEQ (NA)
BITS: SSM-TNC (NA)	NE: AS-CMD (NA)	STSMON: ERFI-P-CONN (NR)
BITS: SYNC-FREQ (NA)	NE: AUD-LOG-LOSS (NA)	STSMON: ERFI-P-SRVR (NR)
BPLANE: AS-CMD (NA)	NE: AUD-LOG-LOW (NA)	STSMON: FAILTOSW-PATH (NA)
BPLANE: MFGMEM (CR)	NE: DATAFLT (MN)	STSMON: FORCED-REQ (NA)
CE100T: GFP-CSF (MJ)	NE: DBOSYNC (MJ)	STSMON: LOCKOUT-REQ (NA)
CE100T: GFP-LFD (MJ)	NE: DUP-IPADDR (MN)	STSMON: LOP-P (CR)
CE100T: GFP-UP-MISMATCH (MJ)	NE: DUP-NODENAME (MN)	STSMON: LPBKCRS (NA)
CE1000: GFP-CSF (MJ)	NE: ETH-LINKLOSS (NA)	STSMON: PDI-P (NA)
CE1000: GFP-LFD (MJ)	NE: HITEMP (CR)	STSMON: RFI-P (NA)
CE1000: GFP-UP-MISMATCH (MJ)	NE: I-HITEMP (CR)	STSMON: SD-P (NA)
CEMR: GFP-CSF (MJ)	NE: INTRUSION-PSWD (NA)	STSMON: SF-P (NA)
CEMR: GFP-LFD (MJ)	NE: LAN-POL-REV (NA)	STSMON: TIM-P (NA)
CEMR: GFP-UP-MISMATCH (MJ)	NE: SNTP-HOST (MN)	STSMON: UNEQ-P (CR)
ENVALRM: EXT (MN)	NE: SYSBOOT (MJ)	STSTRM: AIS-P (NR)
EQPT: ALS-DISABLED (NA)	NE: TEMP-MISM (NA)	STSTRM: AS-MT-OOG (NA)
EQPT: APC-DISABLED (MN)	OCH-TERM: FDI (NA)	STSTRM: ENCAP-MISMATCH-P (CR)
EQPT: AS-CMD (NA)	OCH-TERM: OCHTERM-INC (NA)	STSTRM: ERFI-P-CONN (NR)
EQPT: AS-MT (NA)	OCH-TERM: OPWR-HDEG (MN)	STSTRM: ERFI-P-SRVR (NR)
EQPT: AUTORESET (MN)	OCH-TERM: OPWR-LDEG (MN)	STSTRM: LOP-P (CR)
EQPT: BKUPMEMP (CR)	OCH-TERM: OPWR-LFAIL (CR)	STSTRM: PDI-P (NA)
EQPT: CARLOSS (MJ)	OCH-TERM: PARAM-MISM (NA)	STSTRM: RFI-P (NA)
EQPT: CLDRESTART (NA)		STSTRM: SD-P (NA)
EQPT: CONTBUS-DISABLED (CR)		STSTRM: SF-P (NA)
EQPT: CONTBUS-IO-A (CONTBUS-A) (MN)		STSTRM: TIM-P (NA)
EQPT: CONTBUS-IO-B (CONTBUS-B) (MN)		STSTRM: UNEQ-P (CR)
EQPT: CTNEQPT-MISMATCH (NA)	OCH: APC-CORR-SKIPPED (MN)	TRUNK: AIS (NR)
EQPT: DIAG (CR)	OCH: APC-DISABLED (MN)	TRUNK: AIS-L (NR)
EQPT: EQPT (CR)	OCH: APC-OUT-OF-RANGE (MN)	TRUNK: ALS (NA)
EQPT: EXCCOL (MN)	OCH: AS-CMD (NA)	TRUNK: AS-CMD (NA)
EQPT: FAILTOSW (NA)	OCH: AS-MT (NA)	TRUNK: AS-MT (NA)
EQPT: FAPS-CONFIG-MISMATCH (MN)	OCH: FDI (NA)	TRUNK: CARLOSS (MJ)
EQPT: FORCED-REQ (NA)	OCH: LOS-O (MN)	TRUNK: DSP-COMM-FAIL (MJ)
EQPT: FP-LINK-LOSS (MN)	OCH: LOS-P (CR)	TRUNK: DSP-FAIL (MJ)

Table 2-8 Alarm List by Logical Object in Alarm Profile (continued)

EQPT: FTA-MISMATCH (NA)	OCH: OPWR-HDEG (MN)	TRUNK: EOC (MN)
EQPT: HI-LASERBIAS (MN)	OCH: OPWR-HFAIL (CR)	TRUNK: EOC-L (MN)
EQPT: HI-LASERTEMP (MN)	OCH: OPWR-LDEG (MN)	TRUNK: FAILTOSW (NA)
EQPT: HI-TXPOWER (MN)	OCH: OPWR-LFAIL (CR)	TRUNK: FAPS (NA)
EQPT: HITEMP (MN)	OCH: PARAM-MISM (NA)	TRUNK: FC-NO-CREDITS (MJ)
EQPT: IMPROPRMVL (CR)	OCH: PORT-FAIL (CR)	TRUNK: FEC-MISM (MJ)
EQPT: INHSWPR (NA)	OCH: TRAIL-SIGNAL-FAIL (NA)	TRUNK: FORCED-REQ-SPAN (NA)
EQPT: INHSWWKG (NA)	OCH: VOA-HDEG (MN)	TRUNK: GCC-EOC (MN)
EQPT: LO-LASERBIAS (MN)	OCH: VOA-HFAIL (CR)	TRUNK: GE-OOSYNC (CR)
EQPT: LO-LASERTEMP (MN)	OCH: VOA-LDEG (MN)	TRUNK: HELLO (MN)
EQPT: LO-TXPOWER (MN)	OCH: VOA-LFAIL (CR)	TRUNK: HI-LASERBIAS (MN)
EQPT: LOCKOUT-REQ (NA)	OCHNC-CONN: OCHNC-INC (NA)	TRUNK: HI-RXPOWER (MN)
EQPT: MAN-REQ (NA)	OCN: AIS-L (NR)	TRUNK: HI-TXPOWER (MN)
EQPT: MANRESET (NA)	OCN: ALS (NA)	TRUNK: ILK-FAIL (CR)
EQPT: MEA (CR)	OCN: APS-INV-PRIM (MN)	TRUNK: ISIS-ADJ-FAIL (MN)
EQPT: MEM-GONE (MJ)	OCN: APS-PRIM-FAC (NA)	TRUNK: LO-RXPOWER (MN)
EQPT: MEM-LOW (MN)	OCN: APS-PRIM-SEC-MISM (MN)	TRUNK: LO-TXPOWER (MN)
EQPT: OPEN-SLOT (NA)	OCN: APSB (MN)	TRUNK: LOCKOUT-REQ (NA)
EQPT: PEER-NORESPONSE (MJ)	OCN: APSC-IMP (MN)	TRUNK: LOF (CR)
EQPT: PROTNA (MN)	OCN: APSCDFLTK (MN)	TRUNK: LOM (CR)
EQPT: PWR-FAIL-A (MN)	OCN: APSCINCON (MN)	TRUNK: LOS (CR)
EQPT: PWR-FAIL-B (MN)	OCN: APSCM (MN)	TRUNK: LOS-P (CR)
EQPT: PWR-FAIL-RET-A (MN)	OCN: APSCNMIS (MJ)	TRUNK: LPBKFACILITY (NA)
EQPT: PWR-FAIL-RET-B (MN)	OCN: APSIMP (MN)	TRUNK: LPBKTERMINAL (NA)
EQPT: RS-EOC (MN)	OCN: APSMM (MN)	TRUNK: MANUAL-REQ-SPAN (NA)
EQPT: RS-TIM (CR)	OCN: AS-CMD (NA)	TRUNK: ODUK-1-AIS-PM (NR)
EQPT: RUNCFG-SAVENEED (NA)	OCN: AS-MT (NA)	TRUNK: ODUK-2-AIS-PM (NR)
EQPT: SFTWDOWN (MN)	OCN: AUTOLSROFF (CR)	TRUNK: ODUK-3-AIS-PM (NR)
EQPT: SW-MISMATCH (NA)	OCN: CHANLOSS (NA)	TRUNK: ODUK-4-AIS-PM (NR)
EQPT: UNEQ-P (CR)	OCN: EOC (MN)	TRUNK: ODUK-AIS-PM (NR)
EQPT: VOA-DISABLED (CR)	OCN: EOC-L (MN)	TRUNK: ODUK-BDI-PM (NR)
EQPT: WKSWBK (NA)	OCN: FAILTOSW (NA)	TRUNK: ODUK-LCK-PM (NR)
EQPT: WKSWPR (NA)	OCN: FE-FRCDWKSWBK-SPAN (NA)	TRUNK: ODUK-OCI-PM (NR)
EQPT: WORK-QUEUE-FULL (NA)	OCN: FE-FRCDWKSWPR-SPAN (NA)	TRUNK: ODUK-SD-PM (NA)
EQPT: WTR (NA)	OCN: FE-MANWKSWBK-SPAN (NA)	TRUNK: ODUK-SF-PM (NA)
ESCON: ALS (NA)	OCN: FE-MANWKSWPR-SPAN (NA)	TRUNK: ODUK-TIM-PM (MJ)

Table 2-8 Alarm List by Logical Object in Alarm Profile (continued)

ESCON: AS-CMD (NA)	OCN: FEPRLF (MN)	TRUNK: OTUK-AIS (NR)
ESCON: AS-MT (NA)	OCN: FORCED-REQ-SPAN (NA)	TRUNK: OTUK-BDI (NR)
ESCON: FAILTOSW (NA)	OCN: FRCDWKSWBK-NO-TRFSW (NA)	TRUNK: OTUK-IAE (MN)
ESCON: FORCED-REQ-SPAN (NA)	OCN: FRCDWKSWPR-NO-TRFSW (NA)	TRUNK: OTUK-LOF (CR)
ESCON: HI-LASERBIAS (MN)	OCN: HELLO (MN)	TRUNK: OTUK-SD (NA)
ESCON: HI-RXPOWER (MN)	OCN: HI-LASERBIAS (MN)	TRUNK: OTUK-SF (NA)
ESCON: HI-TXPOWER (MN)	OCN: HI-LASERTEMP (MN)	TRUNK: OTUK-TIM (CR)
ESCON: LO-RXPOWER (MN)	OCN: HI-RXPOWER (MN)	TRUNK: OUT-OF-SYNC (MJ)
ESCON: LO-TXPOWER (MN)	OCN: HI-TXPOWER (MN)	TRUNK: PROV-MISMATCH (MJ)
ESCON: LOCKOUT-REQ (NA)	OCN: ISIS-ADJ-FAIL (MN)	TRUNK: PTIM (MJ)
ESCON: LOS (CR)	OCN: LASEREOL (MN)	TRUNK: RFI (NR)
ESCON: LPBKFACILITY (NA)	OCN: LOCKOUT-REQ (NA)	TRUNK: RFI-L (NR)
ESCON: LPBKTERMINAL (NA)	OCN: LO-LASERBIAS (MN)	TRUNK: SD (NA)
ESCON: MANUAL-REQ-SPAN (NA)	OCN: LO-LASERTEMP (MN)	TRUNK: SD-L (NA)
ESCON: SIGLOSS (MJ)	OCN: LO-RXPOWER (MN)	TRUNK: SF (NA)
ESCON: SQUELCHED (NA)	OCN: LO-TXPOWER (MN)	TRUNK: SF-L (NA)
ESCON: WKSWPR (NA)	OCN: MANUAL-REQ-SPAN (NA)	TRUNK: SIGLOSS (MJ)
ESCON: WTR (NA)	OCN: MANWKSWBK-NO-TRFSW (NA)	TRUNK: SQUELCHED (NA)
EXT-SREF: FRCDSWTOPRI (NA)	OCN: MANWKSWPR-NO-TRFSW (NA)	TRUNK: SSM-DUS (NA)
EXT-SREF: FRCDSWTOSEC (NA)	OCN: RFI-L (NA)	TRUNK: SSM-FAIL (MN)
EXT-SREF: FRCDSWTOTHIRD (NA)	OCN: SD-L (NA)	TRUNK: SSM-LNC (NA)
EXT-SREF: MANSWTOPRI (NA)	OCN: SF-L (NA)	TRUNK: SSM-OFF (NA)
EXT-SREF: MANSWTOSEC (NA)	OCN: SQUELCHED (NA)	TRUNK: SSM-PRC (NA)
EXT-SREF: MANSWTOTHIRD (NA)	OCN: TIM-S (CR)	TRUNK: SSM-PRS (NA)
EXT-SREF: SWTOPRI (NA)	OMS: APC-DISABLED (MN)	TRUNK: SSM-RES (NA)
EXT-SREF: SWTOSEC (NA)	OMS: APC-CORR-SKIPPED (MN)	TRUNK: SSM-SDH-TN (NA)
EXT-SREF: SWTOTHIRD (NA)	OMS: APC-OUT-OF-RANGE (MN)	TRUNK: SSM-SETS (NA)
EXT-SREF: SYNCPRI (MN)	OMS: AS-CMD (NA)	TRUNK: SSM-SMC (NA)
EXT-SREF: SYNCSEC (MN)	OMS: AS-MT (NA)	TRUNK: SSM-ST2 (NA)
EXT-SREF: SYNCTHIRD (MN)	OMS: LOS-O (MN)	TRUNK: SSM-ST3 (NA)
FAN: EQPT-MISS (CR)	OMS: LOS-P (CR)	TRUNK: SSM-ST3E (NA)
FAN: FAN (CR)	OMS: OPWR-HDEG (MN)	TRUNK: SSM-ST4 (NA)
FAN: MEA (CR)	OMS: OPWR-HFAIL (CR)	TRUNK: SSM-STU (NA)
FAN: MFGMEM (CR)	OMS: OPWR-LDEG (MN)	TRUNK: SSM-TNC (NA)

Table 2-8 Alarm List by Logical Object in Alarm Profile (continued)

FC: ALS (NA)	OMS: OPWR-LFAIL (CR)	TRUNK: SYNC-FREQ (NA)
FC: AS-CMD (NA)	OMS: PARAM-MISM (NA)	TRUNK: SYNCLOSS (MJ)
FC: AS-MT (NA)	OMS: PMI (NA)	TRUNK: TIM (CR)
FC: CARLOSS (MJ)	OMS: VOA-HDEG (MN)	TRUNK: TIM-MON (MN)
FC: FAILTOSW (NA)	OMS: VOA-HFAIL (CR)	TRUNK: TRAIL-SIGNAL-FAIL (NA)
FC: FC-NO-CREDITS (MJ)	OMS: VOA-LDEG (MN)	TRUNK: UNC-WORD (NA)
FC: FORCED-REQ-SPAN (NA)	OMS: VOA-LFAIL (CR)	TRUNK: UT-COMM-FAIL (MJ)
FC: GE-OOSYNC (CR)	OSC-RING: RING-ID-MIS (MJ)	TRUNK: UT-FAIL (MJ)
FC: HI-LASERBIAS (MN)	OTS: APC-CORR-SKIPPED (MN)	TRUNK: WTR (NA)
FC: HI-RXPOWER (MN)	OTS: APC-DISABLED (MN)	TRUNK: WVL-MISMATCH (MJ)
FC: HI-TXPOWER (MN)	OTS: APC-OUT-OF-RANGE (MN)	VCMON-HP: AU-AIS (NR)
FC: LO-RXPOWER (MN)	OTS: AS-CMD (NA)	VCMON-HP: AU-LOP (NA)
FC: LO-TXPOWER (MN)	OTS: AS-MT (NA)	VCMON-HP: AUTOSW-AIS-SNCP (NR)
FC: LOCKOUT-REQ (NA)	OTS: AWG-DEG (MN)	VCMON-HP: AUTOSW-LOP-SNCP (NA)
FC: LPBKFACILITY (NA)	OTS: AWG-FAIL (CR)	VCMON-HP: AUTOSW-PDI-SNCP (NA)
FC: LPBKTERMINAL (NA)	OTS: AWG-OVERTEMP (CR)	VCMON-HP: AUTOSW-SDBER-SNCP (NA)
FC: MANUAL-REQ-SPAN (NA)	OTS: AWG-WARM-UP (NA)	VCMON-HP: AUTOSW-SFBER-SNCP (NA)
FC: OUT-OF-SYNC (MJ)	OTS: DCU-LOSS-FAIL (MN)	VCMON-HP: AUTOSW-UNEQ-SNCP (NA)
FC: SIGLOSS (MJ)	OTS: FAILTOSW (NA)	VCMON-HP: FAILTOSW-HO (NA)
FC: SQUELCHED (NA)	OTS: FORCED-REQ-SPAN (NA)	VCMON-HP: FORCED-REQ (NA)
FC: SYNCLOSS (MJ)	OTS: LASERBIAS-DEG (MN)	VCMON-HP: HP-DEG (NA)
FC: WKSWPR (NA)	OTS: LOS (CR)	VCMON-HP: HP-EXC (NA)
FC: WTR (NA)	OTS: LOS-O (MN)	VCMON-HP: HP-PLM (CR)
FCMR: GFP-CSF (MJ)	OTS: LOS-P (CR)	VCMON-HP: HP-RFI (NR)
FCMR: GFP-LFD (MJ)	OTS: LOS-RAMAN (CR)	VCMON-HP: HP-TIM (MN)
FCMR: GFP-UP-MISMATCH (MJ)	OTS: LOCKOUT-REQ (NA)	VCMON-HP: HP-UNEQ (CR)
GE: ALS (NA)	OTS: MANUAL-REQ-SPAN (NA)	VCMON-HP: LOCKOUT-REQ (NA)
GE: AS-CMD (NA)	OTS: MT-OCHNC (NA)	VCMON-HP: LPBKCRS (NA)
GE: AS-MT (NA)	OTS: OPWR-HDEG (MN)	VCMON-HP: SFBER-EXCEED-HO (NA)
GE: CARLOSS (MJ)	OTS: OPWR-HFAIL (CR)	VCMON-LP: AUTOSW-AIS-SNCP (NR)

Table 2-8 Alarm List by Logical Object in Alarm Profile (continued)

GE: FAILTOSW (NA)	OTS: OPWR-LDEG (MN)	VCMON-LP: AUTOSW-LOP-SNCP (NA)
GE: FORCED-REQ-SPAN (NA)	OTS: OPWR-LFAIL (CR)	VCMON-LP: AUTOSW-UNEQ-SNCP (NA)
GE: GE-OOSYNC (CR)	OTS: OSRION (NA)	VCMON-LP: FORCED-REQ (NA)
GE: HI-LASERBIAS (MN)	OTS: PARAM-MISM (NA)	VCMON-LP: LOCKOUT-REQ (NA)
GE: HI-RXPOWER (MN)	OTS: PMI (NA)	VCTRM-HP: AS-MT-OOG (NA)
GE: HI-TXPOWER (MN)	OTS: PWR-PROT-ON (MJ)	VCTRM-HP: AU-AIS (NR)
GE: LMP-FAIL (MN)	OTS: RLS (NA)	VCTRM-HP: AU-LOP (CR)
GE: LMP-SD (MN)	OTS: SH-IL-VAR-DEG-HIGH (MN)	VCTRM-HP: HP-DEG (NA)
GE: LMP-SF (MN)	OTS: SH-IL-VAR-DEG-LOW (MN)	VCTRM-HP: HP-ENCAP-MISMATCH (CR)
GE: LMP-UNALLOC (NA)	OTS: SHUTTER-OPEN (NA)	VCTRM-HP: HP-EXC (NA)
GE: LO-RXPOWER (MN)	OTS: SPAN-NOT-MEASURED (NA)	VCTRM-HP: HP-PLM (CR)
GE: LO-TXPOWER (MN)	OTS: SPANLEN-OUT-OF-RANGE (MN)	VCTRM-HP: HP-TIM (CR)
GE: LOCKOUT-REQ (NA)	OTS: VOA-HDEG (MN)	VCTRM-HP: HP-UNEQ (CR)
GE: LPBKFACILITY (NA)	OTS: VOA-HFAIL (CR)	VCTRM-HP: SFBER-EXCEED-HO (NA)
GE: LPBKTERMINAL (NA)	OTS: VOA-LDEG (MN)	VCTRM-LP: AS-MT-OOG (NA)
GE: MANUAL-REQ-SPAN (NA)	OTS: VOA-LFAIL (CR)	VCTRM-LP: SFBER-EXCEED-HO (NA)
GE: OUT-OF-SYNC (MJ)	OTS: WKSWBK (NA)	—
GE: SIGLOSS (MJ)	OTS: WKSWPR (NA)	—

2.3 Trouble Characterizations

The ONS DWDM system reports trouble by utilizing standard alarm and condition characteristics, standard severities following the rules in Telcordia GR-253-CORE, and graphical user interface (GUI) state indicators. These notifications are described in the following paragraphs.

The ONS System uses standard Telcordia categories to characterize levels of trouble. The system reports trouble notifications as alarms and status or descriptive notifications (if configured to do so) as conditions in the CTC Alarms window. Alarms typically signify a problem that the user needs to remedy, such as a loss of signal. Conditions do not necessarily require troubleshooting.



Note

Unless otherwise specified in this chapter, “ONS 15454” refers to both ANSI and ETSI versions of the platform.



Note

For a description of CTC-view terminology, refer to the “Cisco Transport Controller Operation” chapter in the *Cisco ONS 15454 DWDM Reference Manual*.

2.3.1 Alarm Characteristics

The ONS DWDM system uses standard alarm entities to identify what is causing trouble. All alarms stem from hardware, software, environment, or operator-originated problems whether or not they affect service. Current alarms for the network, CTC session, node, or card are listed in the Alarms tab. (In addition, cleared alarms are also found in the History tab.)

2.3.2 Condition Characteristics

Conditions include any problem detected on an ONS DWDM shelf. They can include standing or transient notifications. A snapshot of all current raised, standing conditions on the network, node, or card can be retrieved in the CTC Conditions window or using TLI's set of RTRV-COND commands. (In addition, some but not all cleared conditions are also found in the History tab.)

For a comprehensive list of all conditions, refer to the *Cisco ONS SONET TLI Command Guide*. For information about transients, see [Chapter 3, “Transient Conditions.”](#)



Note

When an entity is put in the OOS,MT administrative state, the ONS 15454 suppresses all standing alarms on that entity. You can retrieve alarms and events on the Conditions tab. You can change this behavior for the LPBKFACILITY and LPBKTERMINAL alarms. To display these alarms on the Alarms tab, set the NODE.general.ReportLoopbackConditionsOnPortsInOOS-MT to TRUE on the NE Defaults tab.

2.3.3 Severity

The ONS DWDM system uses Telcordia-devised standard severities for alarms and conditions: Critical (CR), Major (MJ), Minor (MN), Not Alarmed (NA) and Not Reported (NR). These are described below:

- A Critical (CR) alarm generally indicates severe, Service-Affecting (SA) trouble that needs immediate correction. Loss of traffic on an STS-1, which can hold 28 DS-1 circuits, would be a Critical (CR), Service-Affecting (SA) alarm.
- A Major (MJ) alarm is a serious alarm, but the trouble has less impact on the network. For example, loss of traffic on more than five DS-1 circuits is Critical (CR), but loss of traffic on one to four DS-1 circuits is Major (MJ).
- Minor (MN) alarms generally are those that do not affect service. For example, the automatic protection switching (APS) byte failure (APSB) alarm indicates that line terminating equipment (LTE) detects a byte failure on the signal that could prevent traffic from properly executing a traffic switch.
- Not Alarmed (NA) conditions are information indicators, such as for free-run synchronization state (FRNGSYNC) or a forced-switch to primary (FRCSWTOPRI) timing event. They could or could not require troubleshooting, as indicated in the entries.
- Not Reported (NR) conditions occur as a secondary result of another event. For example, the alarm indication signal (AIS), with severity NR, is inserted by a downstream node when an LOS (CR or MJ) alarm occurs upstream. These conditions do not in themselves require troubleshooting, but are to be expected in the presence of primary alarms.

Severities can be customized for an entire network or for single nodes, from the network level down to the port level by changing or downloading customized alarm profiles. These custom severities are subject to the standard severity-demoting rules given in Telcordia GR-474-CORE. Procedures for customizing alarm severities are located in the “Manage Alarms” chapter in the *Cisco ONS 15454 DWDM Procedure Guide*.

2.3.4 Service Effect

Service-Affecting (SA) alarms—those that interrupt service—could be Critical (CR), Major (MJ), or Minor (MN) severity alarms. Service-Affecting (SA) alarms indicate service is affected. Non-Service-Affecting (NSA) alarms always have a Minor (MN) default severity.

2.3.5 State

The Alarms or History tab State (ST) column indicate the disposition of the alarm or condition as follows:

- A raised (R) event is one that is active.
- A cleared (C) event is one that is no longer active.
- A transient (T) event is one that is automatically raised and cleared in CTC during system changes such as user login, logout, loss of connection to node/shelf view, etc. Transient events do not require user action. These are listed in [Chapter 3, “Transient Conditions.”](#)

2.4 Safety Summary

This section covers safety considerations designed to ensure safe operation of the ONS DWDM system. Personnel should not perform any procedures in this chapter unless they understand all safety precautions, practices, and warnings for the system equipment. Some troubleshooting procedures require installation or removal of cards; in these instances users should pay close attention to the following caution.

**Caution**

Hazardous voltage or energy could be present on the backplane when the system is operating. Use caution when removing or installing cards.

**Warning**

On the OC-192 card, the laser is on when the card is booted and the safety key is in the on position (labeled 1). The port does not have to be in service for the laser to be on. The laser is off when the safety key is off (labeled 0). Statement 293

**Warning**

Invisible laser radiation could be emitted from the end of the unterminated fiber cable or connector. Do not stare into the beam directly with optical instruments. Viewing the laser output with certain optical instruments (for example, eye loupes, magnifiers, and microscopes) within a distance of 100 mm could pose an eye hazard. Statement 1056

**Warning**

Use of controls, adjustments, or performing procedures other than those specified could result in hazardous radiation exposure. Statement 1057

**Warning**

Class 1 laser product. Statement 1008

**Warning**

Do not reach into a vacant slot or chassis while you install or remove a module or a fan. Exposed circuitry could constitute an energy hazard. Statement 206

**Warning**

The power supply circuitry for the equipment can constitute an energy hazard. Before you install or replace the equipment, remove all jewelry (including rings, necklaces, and watches). Metal objects can come into contact with exposed power supply wiring or circuitry inside the DSLAM equipment. This could cause the metal objects to heat up and cause serious burns or weld the metal object to the equipment. Statement 207

2.5 Trouble-Clearing Procedures

This section lists alarms alphabetically and includes some conditions commonly encountered when troubleshooting alarms. The severity, description, and troubleshooting procedure accompany each alarm and condition.

**Note**

When you check the status of alarms for cards, ensure that the alarm filter icon in the lower right corner of the GUI is not indented. If it is, click it to turn it off. When you are done checking for alarms, you can click the alarm filter icon again to turn filtering back on. For more information about alarm filtering, refer to the “Manage Alarms” chapter in the *Cisco ONS 15454 DWDM Procedure Guide*.

**Note**

When checking alarms, ensure that alarm suppression is not enabled on the card or port. For more information about alarm suppression, refer to the “Manage Alarms” chapter in the *Cisco ONS 15454 DWDM Procedure Guide*.

**Note**

When an entity is put in the OOS,MT administrative state, the ONS 15454 suppresses all standing alarms on that entity. All alarms and events appear on the Conditions tab. You can change this behavior for the LPBKFACILITY and LPBKTERMINAL alarms. To display these alarms on the Alarms tab, set the NODE.general.ReportLoopbackConditionsOnPortsInOOS-MT to TRUE on the NE Defaults tab.

2.5.1 AIS

Default Severity: Not Reported (NR), Non-Service-Affecting (NSA)

Logical Objects: BITS, FUDC, MSUDC

The Alarm Indication Signal (AIS) condition indicates that this node is detecting an alarm indication signal in the incoming signal SONET overhead.

Generally, any AIS is a special SONET signal that communicates to the receiving node when the transmit node does not send a valid signal. AIS is not considered an error. It is raised by the receiving node on each input when it detects the AIS instead of a real signal. In most cases when this condition is raised, an upstream node is raising an alarm to indicate a signal failure; all nodes downstream from it only raise some type of AIS. This condition clears when you resolved the problem on the upstream node.

Clear the AIS Condition

-
- Step 1** Determine whether there are alarms such as LOS on the upstream nodes and equipment or if there are OOS,MT (or Locked,maintenance), or OOS,DSBLD (or Locked,disabled) ports.
 - Step 2** Clear the upstream alarms using the applicable procedures in this chapter.
 - Step 3** If the condition does not clear, log into the Technical Support Website at <http://www.cisco.com/techsupport> for more information or call Cisco TAC (1-800-553-2447).
-

2.5.2 AIS-L

Default Severity: Not Reported (NR), Non-Service-Affecting (NSA)

logical Objects: OCN, TRUNK

The AIS Line condition indicates that this node is detecting line-level AIS in the incoming signal. This alarm is secondary to another alarm occurring simultaneously in an upstream node.

This condition can also be raised in conjunction with the “TIM-S” alarm if AIS-L is enabled. (For more information about the TIM-S alarm, refer to the “Alarm Troubleshooting” chapter in the *Cisco ONS 15454 Troubleshooting Guide*.)



Note

ONS 15454 DS-3 terminal (inward) loopbacks do not transmit an AIS in the direction away from the loopback. Instead of AIS, a continuance of the signal transmitted into the loopback is provided. A DS3/EC1-48 card can be provisioned to transmit AIS for a terminal loopback.

Clear the AIS-L Condition

-
- Step 1** Complete the “[Clear the AIS Condition](#)” procedure on page 2-27.
 - Step 2** If the condition does not clear, log into the Technical Support Website at <http://www.cisco.com/techsupport> for more information or call Cisco TAC (1-800-553-2447).
-

2.5.3 AIS-P

Default Severity: Not Reported (NR), Non-Service-Affecting (NSA)

Logical Object: STSMON, STSTRM

The AIS Path condition means that this node is detecting AIS in the incoming path. This alarm is secondary to another alarm occurring simultaneously in an upstream node.

Clear the AIS-P Condition

-
- Step 1** Complete the “[Clear the AIS Condition](#)” procedure on page 2-27.
- Step 2** If the condition does not clear, log into the Technical Support Website at <http://www.cisco.com/techsupport> for more information or call Cisco TAC (1-800-553-2447).
-

2.5.4 ALS

Default Severity: Not Alarmed (NA), Non-Service-Affecting (NSA)

Logical Objects: 2R, AOTS, ESCON, FC, GE, ISC, OCN, TRUNK

The Automatic Laser Shutdown (ALS) condition occurs when an amplifier card (OPT-BST, or OPT-PRE, OPT-AMP-C, or OMP-AMP-17-C) is switched on. The turn-on process lasts approximately nine seconds, and the condition clears after approximately 10 seconds.



Note

ALS is an informational condition and does not require troubleshooting.

2.5.5 ALS-DISABLED

Default Severity: Not Alarmed (NA), Non-Service-Affecting (NSA)

Logical Object: EQPT

The Automatic Laser Shutdown (ALS) condition occurs when a DWDM Optical Pre-amplifier or Optical Booster (OPT-BST) Amplifier card's ALS is changed to Disabled from any other state (such as Enabled) by user command.

Clear the ALS-DISABLED Condition

-
- Step 1** In node view (single-shelf mode) or shelf view (multishelf mode), double-click the OPT-BST, or OPT-PRE, OPT-AMP-C, or OMP-AMP-17-C card to display the card view.
- Step 2** Click the **Maintenance > ALS** tabs.
- Step 3** In the ALS Mode column, change the entry from Disabled to your required state.
- Step 4** If the condition does not clear, log into the Technical Support Website at <http://www.cisco.com/techsupport> for more information or call Cisco TAC (1-800-553-2447).
-

2.5.6 AMPLI-INIT

Default Severity: Not Alarmed (NA), Non-Service-Affecting (NSA)

Logical Object: AOTS

The Amplifier Initialized condition occurs when an amplifier card (OPT-BST or OPT-PRE) is not able to calculate gain. This condition typically accompanies the [“APC-DISABLED” alarm on page 2-29](#).

**Note**

For basic information about amplifier cards, refer to the “Card Reference” chapter of the *Cisco ONS 15454 DWDM Reference Manual*. For information about gain, refer to the “Network Reference” chapter in the same manual. For information about changing their settings, refer to the “Change DWDM Card Settings” chapter in the *Cisco ONS 15454 DWDM Procedure Guide*.

Clear the AMPLI-INIT Condition

-
- Step 1** Complete the [“Delete a Circuit” procedure on page 2-245](#) on the most recently created circuit.
 - Step 2** Recreate this circuit using the procedures in the “Create Channels and Circuits” chapter of the *Cisco ONS 15454 DWDM Procedure Guide*.
 - Step 3** If the condition does not clear, log onto <http://www.cisco.com/tac> for more information or call TAC (1-800-553-2447).
-

2.5.7 APC-CORR-SKIPPED

Default Severity: Minor (MN), Non-Service-Affecting (NSA)

Logical Objects: AOTS, OCH, OMS, OTS

The Automatic Power Control (APC) Correction Skipped condition occurs when the actual power level of a DWDM channel exceeds the expected setting by 3 dBm or more. APC compares actual power levels with previous power levels every hour or after any channel allocation is performed. If the power difference to be compensated by APC exceeds the range of + 3 dBm or –3 dBm compared with the previous value set, APC is designed not to correct the level and the APC-CORR-SKIPPED condition is raised.

For more information about APC, refer to the “Network Reference” chapter in the *Cisco ONS 15454 DWDM Reference Manual*, and the [“1.12.2 System Restart after a Fiber Cut” section on page 1-70](#).

The APC Correction Skipped alarm strongly limits network management (for example, a new circuit cannot be turned into IS). The Force APC Correction button helps to restore normal conditions by clearing the APC Correction Skipped alarm. For more information about the Force APC Correction button, refer to the “Managing APC” section in “Network Reference” chapter of the *Cisco ONS 15454 DWDM Reference Manual*.

2.5.8 APC-DISABLED

Default Severity: Minor (MN), Non-Service-Affecting (NSA)

Logical Objects: NE, SHELF, AOTS, OTS, OMS, OCH, EQPT

The APC Disabled alarm occurs when the information related to the number of DWDM channels is not reliable. The condition can occur when any of the following related alarms also occur: the [“EQPT” alarm on page 2-72](#), the [“IMPROPRMVL” alarm on page 2-109](#), or the [“MEA \(EQPT\)” alarm on page 2-157](#).

If the condition occurs with the creation of the first circuit, delete and recreate the circuit. (Refer to the “Create Channels and Circuits” chapter of the *Cisco ONS 15454 DWDM Procedure Guide* for information about this.) For more information about APC, refer to the “Network Reference” chapter in the *Cisco ONS 15454 DWDM Reference Manual*.

APC Disabled alarm is raised in the following conditions:

- When you manually disable APC in a given domain to prevent unexpected power regulations during maintenance or troubleshooting.
- When an anomalous event impacting optical regulation occurs.

APC Disabled alarm is disabled in the following conditions:

- An EQPT alarm raised by any of the MSTP units in any of the domain nodes.
- A MEA alarm raised by any of the MSTP equipped cards in any of the domain nodes.
- An IMPROPRMVL alarm is raised by any of the equipped cards in any of the domain nodes.
- Gain Degrade, Power Degrade, Power Fail Alarm is raised by the output port of any Amplifier in any of domain nodes.
- A VOA degrade or fail alarm is raised by any by any of the equipped cards in any of the domain nodes.
- Signalling protocol detects that one of the APC instances in any of the domain nodes is no more reachable
- Not all nodes belonging to domain are set in Metro-Core (e.g. one is configured as Not-DWDM).



Note

The MEA and IMPROPRMVL alarms does not disable APC when raised on OSCM, OSC-CSM, or MXP/TXP cards.

Clear the APC-DISABLED Alarm

-
- Step 1** Complete the appropriate procedure to clear the main alarm:
- [Clear the EQPT Alarm, page 2-73](#)
 - [Clear the IMPROPRMVL Alarm, page 2-110](#)
 - [Clear the MEA \(EQPT\) Alarm, page 2-158](#)
- Step 2** If the condition does not clear, complete the “[Delete a Circuit](#)” procedure on [page 2-245](#) and then recreate it using procedures in the “Create Channels and Circuits” chapter in the *Cisco ONS 15454 DWDM Procedure Guide*.
- Step 3** If the condition does not clear, log into the Technical Support Website at <http://www.cisco.com/techsupport> for more information or call Cisco TAC (1-800-553-2447).
-

2.5.9 APC-END

Default Severity: Not Alarmed (NA), Non-Service-Affecting (NSA)

Logical Object: NE

The APC Terminated on Manual Request condition is raised when APC terminates after it is manually launched from CTC or TL1. APC-END is an informational condition that is raised and cleared spontaneously by the system and is not visible in the CTC Condition window. It is visible only by retrieving it in the Conditions or History tabs. For more information about APC, refer to the “Network Reference” chapter in the *Cisco ONS 15454 DWDM Reference Manual*.

**Note**

APC-END is an informational condition and does not require troubleshooting.

2.5.10 APC-OUT-OF-RANGE

Default Severity: Minor (MN), Non-Service-Affecting (NSA)

Logical Objects: AOTS, OCH, OMS, OTS

The APC Out of Range condition is raised on amplifier cards (OPT-PRE BST , OPT-BST-L, OPT-PRE, OPT-AMP-17-C, OPT-AMP-C, OPT-RAMP-C, OPT-AMP-L, and OPT-BST-E); demultiplexer cards (32-DMX, 40-DMX-C, and 32-DMX-L) having a single variable optical attenuator (VOA); and optical add/drop multiplexer cards (AD-1C-xx.x, AD-2C-xx.x, AD-4C-xx.x, AD-1B-xx.x, and AD-4B-xx.x) when the requested gain or attenuation setpoint cannot be set because it exceeds the port parameter range. For example, this condition is raised when APC attempts to set the OPT-BST gain higher than 20 dBm (the card’s maximum setpoint) or to set the attenuation on the express VOA lower than 0 dBm (its minimum setpoint).

**Note**

A common cause of an amplifier trying to attain a value higher than the maximum setpoint or an attenuator trying to attain a value lower than the minimum setpoint is the low input power.

**Note**

For general information about DWDM cards, refer to the “Card Reference” chapter of the *Cisco ONS 15454 DWDM Reference Manual*. For more information about APC, refer to the “Network Reference” chapter in the same manual. For information about changing their settings, refer to the “Change DWDM Card Settings” chapter in the *Cisco ONS 15454 DWDM Procedure Guide*.

Clear the APC-OUT-OF-RANGE Alarm

- Step 1** There are various root causes for the APC-OUT-OF-RANGE condition. To determine the correct root cause, complete the network-level troubleshooting procedures and node level problems located in [1.13 Node Level \(Intranode\) Problems](#) of [Chapter 1, “General Troubleshooting.”](#)
- Step 2** If the condition does not clear, log into the Technical Support Website at <http://www.cisco.com/techsupport> for more information or call Cisco TAC (1-800-553-2447).

2.5.11 APC-WRONG-GAIN

Default Severity: Not Alarmed (NA), Non-Service-Affecting (NSA)

Logical Object: AOTS

The APC-WRONG-GAIN condition is raised on the amplifier card (OMP-AMP-17-C), when the actual gain of the card (17dB) does not match the expected gain calculated by APC. There is a margin of +1 or -1 dB before the condition is raised.

**Note**

The APC-WRONG-GAIN condition indicates a system issue and not the card problem.

Clear the APC-WRONG-GAIN Alarm

The condition can be cleared by recovering the power at the input port:

-
- Step 1** Check the incoming fiber connection and clean them.
 - Step 2** Check the regulation points (VOA and amplifiers) along the optical path upstream of the OMP-AMP-17-C card.
 - Step 3** If the condition does not clear, log onto <http://www.cisco.com/tac> for more information or call TAC (1-800-553-2447).

2.5.12 APSB

Default Severity: Minor (MN), Non-Service-Affecting (NSA)

Logical Object: OCN, STMN

The APS Channel Byte Failure alarm occurs when LTE detects protection switching byte failure or an invalid switching code in the incoming APS signal. Some older SONET not manufactured by Cisco send invalid APS codes if they are configured in a 1+1 protection group with newer SONET nodes, such as the ONS 15454. These invalid codes cause an APSB alarm on an ONS 15454.

Clear the APSB Alarm

-
- Step 1** Use an optical test set to examine the incoming SONET overhead to confirm inconsistent or invalid K bytes. For specific procedures to use the test set equipment, consult the manufacturer. If corrupted K bytes are confirmed and the upstream equipment is functioning properly, the upstream equipment might not interoperate effectively with the ONS 15454.
 - Step 2** If the alarm does not clear and the overhead shows inconsistent or invalid K bytes, you could need to replace the upstream cards for protection switching to operate properly. Complete the [“Physically Replace a Card” procedure on page 2-244](#).
 - Step 3** If the alarm does not clear, log into the Technical Support Website at <http://www.cisco.com/techsupport> for more information or call Cisco TAC (1-800-553-2447).
-

2.5.13 APSCM

Default Severity: Minor (MN), Non-Service-Affecting (NSA)

Logical Object: OCN, STMN

The APS Channel Mismatch alarm occurs when the ONS 15454 expects a working channel but receives a protect channel. In many cases, the working and protect channels are crossed and the protect channel is active. If the fibers are crossed and the working line is active, the alarm does not occur. The APSCM alarm occurs only on the ONS 15454 when bidirectional protection is used on OC-N cards in a 1+1 protection group configuration. The APSCM alarm does not occur in an optimized 1+1 protection configuration.



Warning

On the ONS 15454 OC-192 card, the laser is on when the card is booted and the safety key is in the on position (labeled 1). The port does not have to be in service for the laser to be on. The laser is off when the safety key is off (labeled 0). Statement 293



Warning

Invisible laser radiation could be emitted from the end of the unterminated fiber cable or connector. Do not stare into the beam directly with optical instruments. Viewing the laser output with certain optical instruments (for example, eye loupes, magnifiers, and microscopes) within a distance of 100 mm could pose an eye hazard. Statement 1056



Warning

Use of controls, adjustments, or performing procedures other than those specified could result in hazardous radiation exposure. Statement 1057

Clear the APSCM Alarm



Caution

Always use the supplied electrostatic discharge wristband when working with a powered ONS 15454. Plug the wristband cable into the ESD jack located on the lower-right edge of the shelf assembly.

- Step 1** Verify that the working-card channel fibers are physically connected directly to the adjoining node's working-card channel fibers.
- Step 2** If the fibers are correctly connected, verify that the protection-card channel fibers are physically connected directly to the adjoining node's protection-card channel fibers.
- Step 3** If the alarm does not clear, log into the Technical Support Website at <http://www.cisco.com/techsupport> for more information or call Cisco TAC (1-800-553-2447) in order to report a Service-Affecting (SA) problem.

2.5.14 APSIMP

Default Severity: Minor (MN), Non-Service-Affecting (NSA)

Logical Object: OCN, STMN

The APS Invalid Code alarm occurs if a 1+1 protection group is not properly configured at both nodes to send or receive the correct APS byte. A node that is either configured for no protection or is configured for path protection or BLSR protection does not send the right K2 APS byte anticipated by a system configured for 1+1 protection. The 1+1 protect port monitors the incoming K2 APS byte and raises this alarm if it does not receive the byte.

The alarm is superseded by an APSCM or APSMM alarm, but not by an AIS condition. It clears when the port receives a valid code for 10 ms.

Clear the APSIMP Alarm

-
- Step 1** Check the configuration of the other node in the 1+1 protection group. If the far end is not configured for 1+1 protection, create the group. For procedures, refer to the “Turn Up Node” chapter in the *Cisco ONS 15454 Procedure Guide*.
 - Step 2** If the other end of the group is properly configured or the alarm does not clear after you have provisioned the group correctly, verify that the working ports and protect ports are cabled correctly.
 - Step 3** Ensure that both protect ports are configured for SONET.
 - Step 4** If the alarm does not clear, log into the Technical Support Website at <http://www.cisco.com/techsupport> for more information or call Cisco TAC (1-800-553-2447).
-

2.5.15 APS-INV-PRIM

Default Severity: Minor (MN), Non-Service Affecting (NSA)

Logical Object: OCN

The Optimized 1+1 APS Primary Facility condition occurs on OC-N cards in an optimized 1+1 protection system if the incoming primary section header does not indicate whether it is primary or secondary.



Note

APS-INV-PRIM is an informational condition and does not require troubleshooting. If the APS switch is related to other alarms, troubleshoot these alarms as necessary using the procedures in this chapter.

2.5.16 APSMM

Default Severity: Minor (MN), Non-Service-Affecting (NSA)

SONET Logical Object: STMN

An APS Mode Mismatch failure alarm occurs on OC-N cards when there is a mismatch of the protection switching schemes at the two ends of the span, such as being bidirectional at one end and unidirectional at the other. Each end of a span must be provisioned the same way: bidirectional and bidirectional, or unidirectional and unidirectional. APSMM can also occur if third-party equipment is provisioned as 1:N and the ONS 15454 is provisioned as 1+1.

If one end is provisioned for 1+1 protection switching and the other is provisioned for path protection switching, an APSMM alarm occurs in the ONS 15454 that is provisioned for 1+1 protection switching.

Clear the APSMM Alarm

-
- Step 1** For the reporting ONS 15454, display node view and verify the protection scheme provisioning:
- Click the **Provisioning > Protection** tabs.
 - Click the 1+1 protection group configured for the OC-N cards.
The chosen protection group is the protection group optically connected (with data communications channel, or DCC, connectivity) to the far end.
 - Click **Edit**.
 - Record whether the Bidirectional Switching check box is checked.
- Step 2** Click **OK** in the Edit Protection Group dialog box.
- Step 3** Log into the far-end node and verify that the OC-N 1+1 protection group is provisioned.
- Step 4** Verify that the Bidirectional Switching check box matches the checked or unchecked condition of the box recorded in [Step 1](#). If not, change it to match.
- Step 5** Click **Apply**.
- Step 6** If the alarm does not clear, log into the Technical Support Website at <http://www.cisco.com/techsupport> for more information or call Cisco TAC (1-800-553-2447).
-

2.5.17 APS-PRIM-FAC

Default Severity: Not Alarmed (NA), Non-Service Affecting (NSA)

Logical Object: OCN

The Optimized 1+1 APS Invalid Primary Section condition occurs on OC-N cards in an optimized 1+1 protection system if there is an APS status switch between the primary and secondary facilities to identify which port is primary.



Note

APS-PRIM-FAC is an informational condition and does not require troubleshooting. If the APS switch is related to other alarms, troubleshoot these alarms as necessary using the procedures in this chapter.

Clear the APS-PRIM-FAC Condition

-
- Step 1** This condition clears when the card receives a valid primary section indication (1 or 2).
- Step 2** If the alarm does not clear, log into the Technical Support Website at <http://www.cisco.com/techsupport> for more information or call Cisco TAC (1-800-553-2447).
-

2.5.18 APS-PRIM-SEC-MISM

Default Severity: Minor (MN), Non-Service Affecting (NSA)

Logical Object: OCN

The Optimized 1+1 APS Primary Section Mismatch condition occurs on OC-N cards in an optimized 1+1 protection system if there is a mismatch between the primary section of the local node facility and the primary section of the remote-node facility.

Clear the APS-PRIM-SEC-MISM Alarm

-
- Step 1** Ensure that the local node and remote-node ports are correctly provisioned the same way. For more information about optimized 1+1 configurations, refer to the “Turn Up Node” chapter in the *Cisco ONS 15454 Procedure Guide*.
- Step 2** If the alarm does not clear, log into the Technical Support Website at <http://www.cisco.com/techsupport> for more information or call Cisco TAC (1-800-553-2447).
-

2.5.19 AS-CMD

Default Severity: Not Alarmed (NA), Non-Service-Affecting (NSA)

Logical Objects: 2R, AOTS, BPLANE, EQPT, ESCON, FC, GE, ISC, NE, OCH, OCN/STMN, OMS, OTS, PPM, PWR, SHELF, TRUNK

The Alarms Suppressed by User Command condition applies to the network element (NE object), backplane (BPLANE object), a single MXP or TXP card, or a port on one of these cards. It occurs when alarms are suppressed for that object and its subordinate objects. For example, suppressing alarms on a card also suppresses alarms on its ports.



Note For more information about suppressing alarms, refer to the “Manage Alarms” chapter in the *Cisco ONS 15454 DWDM Procedure Guide*.



Note This condition is not raised for multiservice transport platform (MSTP) cards such as amplifiers, multiplexers, or demultiplexers.

Clear the AS-CMD Condition

-
- Step 1** For all nodes, in node view (single-shelf mode) or shelf view (multishelf mode), click the **Conditions** tab.
- Step 2** Click **Retrieve**. If you have already retrieved conditions, look under the Object column and Eqpt Type column and note what entity the condition is reported against, such as a port, slot, or shelf.
- If the condition is reported against a slot and card, alarms were either suppressed for the entire card or for one of the ports. Note the slot number and continue with [Step 3](#).
 - If the condition is reported against the backplane, go to [Step 7](#).
 - If the condition is reported against the NE object, go to [Step 8](#).
- Step 3** Determine whether alarms are suppressed for a port and if so, raise the suppressed alarms:
- a. Double-click the card to open the card view.

- b. Click the **Provisioning > Alarm Profiles > Alarm Behavior** tabs and complete one of the following substeps:
 - If the Suppress Alarms column check box is checked for a port row, deselect it and click **Apply**.
 - If the Suppress Alarms column check box is not checked for a port row, from the View menu choose **Go to Previous View**.
- Step 4** If the AS-CMD condition is reported for a card and not an individual port, in node view (single-shelf mode) or shelf view (multishelf mode), click the **Provisioning > Alarm Profiles > Alarm Behavior** tabs.
- Step 5** Locate the row number for the reported card slot.
- Step 6** Click the **Suppress Alarms** column check box to deselect the option for the card row.
- Step 7** If the condition is reported for the backplane, the alarms are suppressed for cards such as the ONS 15454 AIP that are not in the optical or electrical slots. To clear the alarm, complete the following steps:
- a. Click the **Provisioning > Alarm Profiles > Alarm Behavior** tabs.
 - b. In the backplane row, uncheck the **Suppress Alarms** column check box.
 - c. Click **Apply**.
- Step 8** If the condition is reported for the shelf, cards and other equipment are affected. To clear the alarm, complete the following steps:
- a. In node view (single-shelf mode) or shelf view (multishelf mode), click the **Provisioning > Alarm Profiles > Alarm Behavior** tabs if you have not already done so.
 - b. Click the **Suppress Alarms** check box located at the bottom of the window to deselect the option.
 - c. Click **Apply**.
- Step 9** If the condition does not clear, log into the Technical Support Website at <http://www.cisco.com/techsupport> for more information or call Cisco TAC (1-800-553-2447).
-

2.5.20 AS-MT

Default Severity: Not Alarmed (NA), Non-Service-Affecting (NSA)

Logical Objects: 2R, AOTS, EQPT, ESCON, FC, GE, ISC, OCH, OCN/STMN, OMS, OTS, PPM, SHELF, TRUNK

The Alarms Suppressed for Maintenance Command condition applies to MXP or TXP cards and occurs when a client or trunk port is placed in the Out-of-Service and Management, Maintenance (OOS-MA,MT or Locked,enabled, loopback & maintenance) service state for loopback testing operations.

While provisioning traffic between two MXP-MR-10DME, MXP-MR-2.5G, or MXPP-MR-2.5G cards, putting the trunk port (09) of the card OOS-MT (initially IS) results in the AS-MT alarm being reported on both trunk and client port. This is because all the GFP interfaces derive their state from the trunk state if the trunk is not IS-NR. If the Trunk port state is IS-NR, then all the GFP interfaces derive their state from the corresponding client port. When the trunk is moved to AS-MT, which is not IS, the GFP of the client port also moves to the AS-MT state. The FAC of the client does not change state.

Clear the AS-MT Condition

-
- Step 1** Complete the “[Clear an MXP, TXP, GE-XP, 10GE-XP, and ADM-10G Card Loopback Circuit](#)” procedure on page 2-245.
- Step 2** If the condition does not clear, log into the Technical Support Website at <http://www.cisco.com/techsupport> for more information or call Cisco TAC (1-800-553-2447).
-

2.5.21 AU-AIS

Default Severity: Not Reported (NR), Non-Service-Affecting (NSA)

Logical Object: VCMON-HP, VCTRM-HP

An AU AIS condition applies to the administration unit, which consists of the virtual container (VC) capacity and pointer bytes (H1, H2, and H3) in the SDH frame.

Generally, any AIS is a special SDH signal that communicates to the receiving node when the transmit node does not send a valid signal. AIS is not considered an error. It is raised by the receiving node on each input when it detects the AIS instead of a real signal. In most cases when this condition is raised, an upstream node is raising an alarm to indicate a signal failure; all nodes downstream from it only raise some type of AIS. This condition clears when you resolved the problem on the upstream node.

Clear the AU-AIS Condition

-
- Step 1** Complete the “[Clear the AIS Condition](#)” procedure on page 2-27.
- Step 2** If the condition does not clear, complete the “[Clear the APSB Alarm](#)” procedure on page 2-32.
- Step 3** If the condition does not clear, log into the Technical Support Website at <http://www.cisco.com/techsupport> for more information or log into <http://www.cisco.com/warp/public/687/Directory/DirTAC.shtml> to obtain a directory of toll-free Technical Support numbers for your country.
-

2.5.22 AU-LOP

Default Severity: Critical (CR), Service-Affecting (SA)

Logical Objects: VCMON-HP, VCTRM-HP

An AU-LOP alarm indicates that the SDH high order path overhead section of the administration unit has detected a loss of path. AU-LOP occurs when there is a mismatch between the expected and provisioned circuit size. For the TXP card, an AU-LOP is raised if a port is configured for an SDH signal but receives a SDH signal instead. (This information is contained in the H1 byte bits 5 and 6.)



Warning

Invisible laser radiation could be emitted from the end of the unterminated fiber cable or connector. Do not stare into the beam directly with optical instruments. Viewing the laser output with certain optical instruments (for example, eye loupes, magnifiers, and microscopes) within a distance of 100 mm could pose an eye hazard. Statement 1056

**Warning**

Use of controls, adjustments, or performing procedures other than those specified could result in hazardous radiation exposure. Statement 1057

**Note**

For more information about MXP and TXP cards, refer to the *Cisco ONS 15454 SDH Reference Manual*.

Clear the AU-LOP Alarm

-
- Step 1** In node view, click the **Circuits** tab and view the alarmed circuit.
- Step 2** Verify that the correct circuit size is listed in the Size column. If the size is different from what is expected, such as a VC4-4c instead of a VC4, this causes the alarm.
- Step 3** If you have been monitoring the circuit with optical test equipment, a mismatch between the provisioned circuit size and the size expected by the test set can cause this alarm. Ensure that the test set monitoring is set up for the same size as the circuit provisioning. For specific procedures to use the test set equipment, consult the manufacturer.
- Step 4** If you have not been using a test set, or if the test set is correctly set up, the error is in the provisioned CTC circuit size. Complete the “[Delete a Circuit](#)” procedure on page 2-245.
- Step 5** Recreate the circuit for the correct size. For procedures, refer to the “Create Circuits and Tunnels” chapter in the *Cisco ONS 15454 Procedure Guide*.
- Step 6** If the alarm does not clear, log into the Technical Support Website at <http://www.cisco.com/techsupport> for more information or log into <http://www.cisco.com/warp/public/687/Directory/DirTAC.shtml> to obtain a directory of toll-free Technical Support numbers for your country in order to report a Service-Affecting (SA) problem.
-

2.5.23 AUTOLSROFF

Default Severity: Critical (CR), Service-Affecting (SA)

Logical Object: STMN

The Auto Laser Shutdown alarm occurs when the STM-64 card temperature exceeds 194 degrees F (90 degrees C). The internal equipment automatically shuts down the STM-64 laser when the card temperature rises to prevent the card from self-destructing.

**Warning**

On the OC192 LR/STM64 LH 1550 card, the laser is on when the card is booted and the safety key is in the on position (labeled 1). The port does not have to be in service for the laser to be on. The laser is off when the safety key is off (labeled 0). Statement 293.

**Warning**

Invisible laser radiation could be emitted from the end of the unterminated fiber cable or connector. Do not stare into the beam directly with optical instruments. Viewing the laser output with certain optical instruments (for example, eye loupes, magnifiers, and microscopes) within a distance of 100 mm could pose an eye hazard. Statement 1056

**Warning**

Use of controls, adjustments, or performing procedures other than those specified could result in hazardous radiation exposure. Statement 1057

Clear the AUTOLSROFF Alarm

- Step 1** View the temperature displayed on the ONS 15454 LCD front panel (Figure 2-2).
Figure 2-2 shows the shelf LCD panel.

Figure 2-1 Shelf LCD Panel

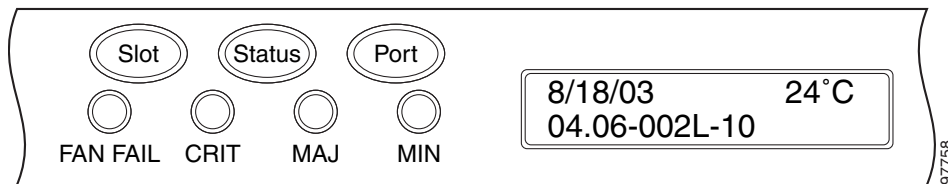

- Step 2** If the temperature of the shelf exceeds 194 degrees F (90 degrees C), the alarm should clear if you solve the ONS 15454 temperature problem. Complete the “Clear the HITEMP Alarm” procedure on page 2-100.
- Step 3** If the temperature of the shelf is under 194 degrees F (90 degrees C), the HITEMP alarm is not the cause of the AUTOLSROFF alarm. Complete the “Physically Replace a Card” procedure on page 2-244 for the OC-192 card.



Note When you replace a card with the identical type of card, you do not need to make any changes to the database.

- Step 4** If card replacement does not clear the alarm, log into the Technical Support Website at <http://www.cisco.com/techsupport> for more information or log into <http://www.cisco.com/warp/public/687/Directory/DirTAC.shtml> to obtain a directory of toll-free Technical Support numbers for your country in order to report a Service-Affecting (SA) problem.

2.5.24 AUTORESET

Default Severity: Minor (MN), Non-Service-Affecting (NSA)

Logical Object: EQPT

The Automatic System Reset alarm occurs when you change an IP address or perform any other operation that causes an automatic card-level reboot. AUTORESET typically clears after a card reboots (up to ten minutes).

Resets performed during a software upgrade also prompt the condition. This condition clears automatically when the card finishes resetting. If the alarm does not clear, complete the following procedure.

Clear the AUTORESET Alarm

Step 1 Determine whether there are additional alarms that could have triggered an automatic reset. If there are, troubleshoot these alarms using the applicable section of this chapter.

Step 2 If the card automatically resets more than once a month with no apparent cause, complete the “[Physically Replace a Card](#)” procedure on page 2-244.

**Warning**

Warning: High-performance devices on this card can get hot during operation. To remove the card, hold it by the faceplate and bottom edge. Allow the card to cool before touching any other part of it or before placing it in an antistatic bag. Statement 201

Step 3 If the alarm does not clear, log into the Technical Support Website at <http://www.cisco.com/techsupport> for more information or call Cisco TAC (1-800-553-2447).

2.5.25 AUTOSW-AIS

Default Severity: Not Reported (NR), Non-Service-Affecting (NSA)

Logical Object: STSMON, VT-MON

The Automatic Path Protection Switch Caused by an AIS condition indicates that automatic path protection switching occurred because of an AIS condition. If the path protection is configured for revertive switching, it reverts to the working path after the fault clears. The AIS also clears when the upstream trouble is cleared.

**Note**

This condition is only reported if the path protection is set up for revertive switching.

Generally, any AIS is a special SONET signal that communicates to the receiving node when the transmit node does not send a valid signal. AIS is not considered an error. It is raised by the receiving node on each input when it detects the AIS instead of a real signal. In most cases when this condition is raised, an upstream node is raising an alarm to indicate a signal failure; all nodes downstream from it only raise some type of AIS. This condition clears when you resolved the problem on the upstream node.

Clear the AUTOSW-AIS Condition

Step 1 Complete the “[Clear the AIS Condition](#)” procedure on page 2-27.

Step 2 If the condition does not clear, log into the Technical Support Website at <http://www.cisco.com/techsupport> for more information or call Cisco TAC (1-800-553-2447).

2.5.26 AUTOSW-AIS-SNCP

Default Severity: Not Reported (NR), Non-Service-Affecting (NSA)

Logical Object: VCMON-HP, VCMON-LP

The Automatic path protection Switch Caused by an AIS condition indicates that automatic path protection switching occurred because of the TU-AIS condition. If the path protection ring is configured for revertive switching, it switches back to the working path after the fault clears. The AUTOSW-AIS-path protection clears when you clear the primary alarm on the upstream node.

**Note**

This condition is only reported if the SNCP is set up for revertive switching.

Generally, any AIS is a special SONET signal that communicates to the receiving node when the transmit node does not send a valid signal. AIS is not considered an error. It is raised by the receiving node on each input when it detects the AIS instead of a real signal. In most cases when this condition is raised, an upstream node is raising an alarm to indicate a signal failure; all nodes downstream from it only raise some type of AIS. This condition clears when you resolved the problem on the upstream node.

Clear the AUTOSW-AIS-path protection Condition

-
- Step 1** Complete the “[Clear the AIS Condition](#)” procedure on page 2-27.
- Step 2** If the condition does not clear, log into the Technical Support Website at <http://www.cisco.com/techsupport> for more information or log into <http://www.cisco.com/warp/public/687/Directory/DirTAC.shtml> to obtain a directory of toll-free Technical Support numbers for your country.
-

2.5.27 AUTOSW-LOP (STSMON)

Default Severity: Not Alarmed (NA), Non-Service-Affecting (NSA)

Logical Object: STSMON

The Automatic Path Protection Switch Caused by LOP condition for the STS monitor (STSMON) indicates that automatic path protection switching occurred because of the “[LOP-P](#)” alarm on [page 2-131](#). If the path protection is configured for revertive switching, it reverts to the working path after the fault clears.

**Note**

This condition is only reported if the path protection is set up for revertive switching.

Clear the AUTOSW-LOP (STSMON) Condition

-
- Step 1** Complete the “[Clear the LOP-P Alarm](#)” procedure on page 2-131.
- Step 2** If the condition does not clear, log into the Technical Support Website at <http://www.cisco.com/techsupport> for more information or call Cisco TAC (1-800-553-2447).
-

2.5.28 AUTOSW-LOP-SNCP

Default Severity: Not Alarmed (NA), Non-Service-Affecting (NSA)

Logical Object: VCMON-HP, VCMON-LP

An Automatic path protection Switch Caused by LOP alarm indicates that an automatic path protection protection switching occurred because of the “AU-LOP” alarm, page 2-38. If the path protection ring is configured for revertive switching, it switches back to the working path after the fault clears.



Note

This condition is only reported if the SNCP is set up for revertive switching.

Clear the AUTOSW-LOP-SNCP Alarm

-
- Step 1** Complete the “Clear the AU-LOP Alarm” procedure on page 2-39.
- Step 2** If the alarm does not clear, log into the Technical Support Website at <http://www.cisco.com/techsupport> for more information or log into <http://www.cisco.com/warp/public/687/Directory/DirTAC.shtml> to obtain a directory of toll-free Technical Support numbers for your country.
-

2.5.29 AUTOSW-PDI

Default Severity: Not Alarmed (NA), Non-Service-Affecting (NSA)

Logical Object: STSMON, VT-MON

The Automatic Path Protection Switch Caused by Payload Defect Indication (PDI) condition indicates that automatic path protection switching occurred because of a “PDI-P” alarm on page 2-186. If the path protection is configured for revertive switching, it reverts to the working path after the fault clears.



Note

This condition is only reported if the path protection is set up for revertive switching.

Clear the AUTOSW-PDI Condition

-
- Step 1** Complete the “Clear the PDI-P Condition” procedure on page 2-187.
- Step 2** If the condition does not clear, log into the Technical Support Website at <http://www.cisco.com/techsupport> for more information or call Cisco TAC (1-800-553-2447).
-

2.5.30 AUTOSW-PDI-SNCP

Default Severity: Not Alarmed (NA), Non-Service-Affecting (NSA)

Logical Object: VCMON-HP, VCMON-LP

The Automatic path protection Switch Caused by Payload Defect Indication (PDI) condition indicates that automatic path protection protection switching occurred because of a PDI alarm. If the path protection is configured for revertive switching, it reverts to the working path after the fault clears.

**Note**

This condition is only reported if the SNCP is set up for revertive switching.

Clear the AUTOSW-PDI-SNCP Condition

- Step 1** Complete the “[Clear the PDI-P Condition](#)” section on page 2-187.
- Step 2** If the condition does not clear, log into the Technical Support Website at <http://www.cisco.com/techsupport> for more information or log into <http://www.cisco.com/warp/public/687/Directory/DirTAC.shtml> to obtain a directory of toll-free Technical Support numbers for your country.
-

2.5.31 AUTOSW-SDBER

Default Severity: Not Alarmed (NA), Non-Service-Affecting (NSA)

Logical Object: STSMON, VT-MON

The Automatic Path Protection Switch Caused by Signal Degrade Bit Error Rate (SDBER) condition indicates that a “[SD-P](#)” condition on page 2-202 caused automatic path protection switching to occur. If the path protection is configured for revertive switching, the path protection reverts to the working path when the SD-P is resolved.

**Note**

This condition is only reported if the path protection is set up for revertive switching.

Clear the AUTOSW-SDBER Condition

- Step 1** Complete the “[Clear the SD-P Condition](#)” procedure on page 2-203.
- Step 2** If the condition does not clear, log into the Technical Support Website at <http://www.cisco.com/techsupport> for more information or call Cisco TAC (1-800-553-2447).
-

2.5.32 AUTOSW-SDBER-SNCP

Default Severity: Not Alarmed (NA), Non-Service-Affecting (NSA)

Logical Object: VCMON-HP, VCMON-LP

The Automatic path protection Switch Caused by Signal Degrade Bit Error Rate (SDBER) condition indicates that a signal degrade caused automatic path protection protection switching to occur. If the path protection ring is configured for revertive switching, it reverts to the working path when the SD is resolved.

**Note**

This condition is only reported if the SNCP is set up for revertive switching.

Clear the AUTOSW-SDBER-SNCP Condition

-
- Step 1** Complete the “[Clear the SD \(TRUNK\) Condition](#)” procedure on page 2-201.
- Step 2** If the condition does not clear, log into the Technical Support Website at <http://www.cisco.com/techsupport> for more information or log into <http://www.cisco.com/warp/public/687/Directory/DirTAC.shtml> to obtain a directory of toll-free Technical Support numbers for your country.
-

2.5.33 AUTOSW-SFBER

Default Severity: Not Alarmed (NA), Non-Service-Affecting (NSA)

Logical Object: STSMON, VT-MON

The Automatic USPR Switch Caused by Signal Fail Bit Error Rate (SFBER) condition indicates that a “[SF-P](#)” condition on page 2-206 caused automatic path protection switching to occur. If the path protection is configured for revertive switching, the path protection reverts to the working path when the SF-P is resolved.



Note This condition is only reported if the path protection is set up for revertive switching.

Clear the AUTOSW-SFBER Condition

-
- Step 1** Complete the “[Clear the SF-P Condition](#)” procedure on page 2-206.
- Step 2** If the condition does not clear, log into the Technical Support Website at <http://www.cisco.com/techsupport> for more information or call Cisco TAC (1-800-553-2447).
-

2.5.34 AUTOSW-SFBER-SNCP

Default Severity: Not Alarmed (NA), Non-Service-Affecting (NSA)

Logical Object: VCMON-HP, VCMON-LP

The Automatic path protection Switch Caused by Signal Fail Bit Error Rate (SFBER) condition indicates that a signal fail caused automatic path protection protection switching to occur. If the path protection ring is configured for revertive switching, it reverts to the working path when the SF is resolved.



Note This condition is only reported if the SNCP is set up for revertive switching.

Clear the AUTOSW-SFBER-SNCP Condition

-
- Step 1** Complete the “[Clear the SF \(TRUNK\) Condition](#)” procedure on page 2-204.

- Step 2** If the condition does not clear, log into the Technical Support Website at <http://www.cisco.com/techsupport> for more information or log into <http://www.cisco.com/warp/public/687/Directory/DirTAC.shtml> to obtain a directory of toll-free Technical Support numbers for your country.

2.5.35 AUTOSW-UNEQ (STSMON)

Default Severity: Not Alarmed (NA), Non-Service-Affecting (NSA)

Logical Object: STSMON

The Automatic Path Protection Switch Caused by Unequipped condition indicates that an “UNEQ-P” alarm on page 2-226, caused automatic path protection switching to occur. If the path protection is configured for revertive switching, it reverts to the working path after the fault clears.



Note

This condition is only reported if the path protection is set up for revertive switching.

Clear the AUTOSW-UNEQ (STSMON) Condition

- Step 1** Complete the “Clear the UNEQ-P Alarm” procedure on page 2-226.
- Step 2** If the condition does not clear, log into the Technical Support Website at <http://www.cisco.com/techsupport> for more information or call Cisco TAC (1-800-553-2447).

2.5.36 AUTOSW-UNEQ-SNCP (VCMON-HP)

Default Severity: Not Alarmed (NA), Non-Service-Affecting (NSA)

Logical Object: VCMON-HP

The Automatic path protection Switch Caused by an Unequipped condition indicates that an HP-UNEQ alarm caused automatic path protection protection switching to occur (see the “HP-UNEQ” alarm, page 2-107). If the path protection ring is configured for revertive switching, it reverts to the working path after the fault clears.



Warning

Class 1 laser product. Statement 1008



Warning

Class 1M laser radiation when open. Do not view directly with optical instruments. Statement 1053



Warning

Invisible laser radiation could be emitted from the end of the unterminated fiber cable or connector. Do not stare into the beam directly with optical instruments. Viewing the laser output with certain optical instruments (for example, eye loupes, magnifiers, and microscopes) within a distance of 100 mm could pose an eye hazard. Statement 1056

**Warning**

Use of controls, adjustments, or performing procedures other than those specified could result in hazardous radiation exposure. Statement 1057

**Note**

This condition is only reported if the SNCP is set up for revertive switching.

Clear the AUTOSW-UNEQ-SNCP (VCMON-HP) Condition

-
- Step 1** Complete the “Clear the HP-UNEQ Alarm” procedure on page 2-107.
- Step 2** If the alarm does not clear, log into the Technical Support Website at <http://www.cisco.com/techsupport> for more information or log into <http://www.cisco.com/warp/public/687/Directory/DirTAC.shtml> to obtain a directory of toll-free Technical Support numbers for your country.
-

2.5.37 AWG-DEG

Default Severity: Minor (MN), Non-Service-Affecting (NSA)

Logical Object: OTS

The Arrayed Waveguide Gratings (AWG) Degrade alarm occurs when a 32MUX-O, 40MUX, 32WSS-O, 40WSSC-C, 32DMX-O, 32DMX, or 40DMX card heater-control circuit degrades. The heat variance can cause slight wavelength drift. The card does not need to be replaced immediately, but it should be at the next opportunity.

**Note**

For General information about 32MUX-O, 40MUX, 32WSS-O, 40WSSC-C, 32DMX-O, 32DMX, and 40DMX cards, refer to the “Card Reference” chapter of the *Cisco ONS 15454 DWDM Reference Manual*. For more information about changing their settings, refer to the “Change DWDM Card Settings” chapter in the *Cisco ONS 15454 DWDM Procedure Guide*.

Clear the AWG-DEG Alarm

-
- Step 1** For the alarmed 32MUX-O, 40MUX, 32WSS-O, 40WSSC-C, 32DMX-O, 32DMX, or 40DMX card, complete the “Physically Replace a Card” procedure on page 2-244 at the next opportunity.

**Warning**

Warning: High-performance devices on this card can get hot during operation. To remove the card, hold it by the faceplate and bottom edge. Allow the card to cool before touching any other part of it or before placing it in an antistatic bag. Statement 201

- Step 2** If the alarm does not clear, log into the Technical Support Website at <http://www.cisco.com/techsupport> for more information or call Cisco TAC (1-800-553-2447).
-

2.5.38 AWG-FAIL

Default Severity: Critical (CR), Service-Affecting (SA)

Logical Object: OTS

The AWG Failure alarm occurs when a 32MUX-O, 40MUX, 32WSS-O, 40WSSC-C, 32DMX-O, 32DMX, or 40DMX card heater-control circuit completely fails. The circuit failure disables wavelength transmission. The card must be replaced to restore traffic.



Note

For general information about 32MUX-O, 40MUX, 32WSS-O, 40WSSC-C, 32DMX-O, 32DMX, and 40DMX cards, refer to the “Card Reference” chapter of the *Cisco ONS 15454 DWDM Reference Manual*. For information about changing their settings, refer to the “Change DWDM Card Settings” chapter in the *Cisco ONS 15454 DWDM Procedure Guide*.

Clear the AWG-FAIL Alarm

- Step 1** For the alarmed 32MUX-O, 40MUX, 32WSS-O, 40WSSC-C, 32DMX-O, 32DMX, or 40DMX card, complete the [“Physically Replace a Card” procedure on page 2-244](#).



Warning

Warning: High-performance devices on this card can get hot during operation. To remove the card, hold it by the faceplate and bottom edge. Allow the card to cool before touching any other part of it or before placing it in an antistatic bag. Statement 201

- Step 2** If the alarm does not clear, log into the Technical Support Website at <http://www.cisco.com/techsupport> for more information or call Cisco TAC (1-800-553-2447) to report a Service-Affecting (SA) problem.

2.5.39 AWG-OVERTEMP

Default Severity: Critical (CR), Service-Affecting (SA)

Logical Object: OTS

The AWG Over Temperature alarm is raised if a 32MUX-O, 40MUX, 32WSS-O, 40WSSC-C, 32DMX-O, 32DMX, or 40DMX card having an AWG-FAIL alarm is not replaced and its heater-control circuit temperature exceeds 212 degrees F (100 degrees C). The card goes into protect mode and the heater is disabled.



Note

For general information about these cards, refer to the “Card Reference” chapter in the *Cisco ONS 15454 DWDM Reference Manual*. For information about changing their settings, refer to the “Change DWDM Card Settings” chapter in the *Cisco ONS 15454 DWDM Procedure Guide*.

Clear the AWG-OVERTEMP Alarm

- Step 1** Complete the [“Clear the AWG-FAIL Alarm” procedure on page 2-48](#).

- Step 2** If the alarm does not clear, log into the Technical Support Website at <http://www.cisco.com/techsupport> for more information or call Cisco TAC (1-800-553-2447) to report a Service-Affecting (SA) problem.
-

2.5.40 AWG-WARM-UP

Default Severity: Not Alarmed (NA), Non-Service-Affecting (NSA)

Logical Object: OTS

The AWG Warm-Up condition occurs when a 32MUX-O, 40MUX, 32WSS-O, 40WSSC-C, 32DMX-O, 32DMX, or 40DMX card heater-control circuit is attaining its operating temperature during startup. The condition lasts approximately 10 minutes but can vary somewhat from this period due to environmental temperature.



Note

AWG-WARM-UP is an informational condition and does not require troubleshooting.

2.5.41 BAT-FAIL

Default Severity: Major (MJ), Service-Affecting (SA)

Logical Object: PWR

The Battery Fail alarm occurs when one of the two power supplies (A or B) is not detected. This could be because the supply is removed or is not operational. The alarm does not distinguish between the individual power supplies, so onsite information about the conditions is necessary for troubleshooting.

Clear the BAT-FAIL Alarm

- Step 1** At the site, determine which battery is not present or operational.
- Step 2** Remove the power cable from the faulty supply. For procedures, refer to the “Install the Shelf and Common Control Cards” chapter in the *Cisco ONS 15454 DWDM Procedure Guide*. Reverse the power cable installation procedure.
- Step 3** If the alarm does not clear, log into the Technical Support Website at <http://www.cisco.com/techsupport> for more information or call Cisco TAC (1-800-553-2447) in order to report a Service-Affecting (SA) problem.
-

2.5.42 BKUPMEMP

Default Severity: Critical (CR), Service-Affecting (SA)

Logical Object: EQPT

The Primary Nonvolatile Backup Memory Failure alarm refers to a problem with the TCC2/TCC2P card flash memory. The alarm occurs when the TCC2/TCC2P card is in use and has one of four problems:

- Flash manager fails to format a flash partition.

- Flash manager fails to write a file to a flash partition.
- Problem at the driver level.
- Code volume fails cyclic redundancy checking (CRC, which is a method to verify for errors in data transmitted to the TCC2/TCC2P card).

The BKUPMEMP alarm can also cause the “EQPT” alarm, page 2-72. If the EQPT alarm is caused by BKUPMEMP, complete the following procedure to clear the BKUPMEMP and the EQPT alarm.

**Caution**

A software update on a standby TCC2/TCC2P card can take up to 30 minutes.

Clear the BKUPMEMP Alarm

- Step 1** Verify that both TCC2/TCC2P cards are powered and enabled by confirming lighted ACT/SBY LEDs on the TCC2/TCC2P cards.
- Step 2** Determine whether the active or standby TCC2/TCC2P card has the alarm.
- Step 3** If both TCC2/TCC2P cards are powered and enabled, reset the TCC2/TCC2P card where the alarm is raised. If the card is the active TCC2/TCC2P card, complete the “[Reset an Active TCC2/TCC2P Card and Activate the Standby Card](#)” procedure on page 2-241. If the card is the standby TCC2/TCC2P card:
- Right-click the standby TCC2/TCC2P card in CTC.
 - Choose **Reset Card** from the shortcut menu.
 - Click **Yes** in the Are You Sure dialog box. The card resets, the FAIL LED blinks on the physical card.
 - Wait ten minutes to verify that the card you reset completely reboots.
- Step 4** If the TCC2/TCC2P card you reset does not reboot successfully, or the alarm has not cleared, call Cisco TAC (1-800-553-2447). If the Cisco TAC technician tells you to reseat the card, complete the “[Remove and Reinsert \(Reseat\) the Standby TCC2/TCC2P Card](#)” procedure on page 2-242. If the Cisco TAC technician tells you to remove the card and reinstall a new one, follow the “[Physically Replace a Card](#)” procedure on page 2-244.

**Warning**

Warning: High-performance devices on this card can get hot during operation. To remove the card, hold it by the faceplate and bottom edge. Allow the card to cool before touching any other part of it or before placing it in an antistatic bag. Statement 201

2.5.43 BPV

Default Severity: Minor (MN), Non-Service-Affecting (NSA)

Logical Object: BITS

The 64K Clock Bipolar Density Violation alarm is raised on the TCC2P card if there is a frequency variation in the 8K BITS clock.

The TCC2P card contains an 8K clock and a 64K clock. Each has some bipolar variation, which is normal. This alarm is raised on the 8K clock if that variation discontinues. The BPV alarm is demoted by an LOF or LOS against the BITS clock.



Note This alarm is not raised on the TCC2 card.

Clear the BPV Alarm

-
- Step 1** Reestablish a normal BITS input signal to clear the alarm. Clear any alarms on the incoming signal or against the BITS timing sources.
- Step 2** If the alarm does not clear, log into the Technical Support Website at <http://www.cisco.com/techsupport> for more information or call Cisco TAC (1-800-553-2447) in order to report a Service-Affecting (SA) problem.
-

2.5.44 CARLOSS (EQPT)

Default Severity: Major (MJ), Service-Affecting (SA)

Logical Object: EQPT

A Carrier Loss on the LAN Equipment alarm generally occurs on MXP, TXP, or ADM-10G cards when the ONS system and the workstation hosting CTC do not have a TCP/IP connection. The problem involves the LAN or data circuit used by the RJ-45 (LAN) connector on the TCC2/TCC2P card or the LAN backplane pin connection. This CARLOSS alarm does not involve an Ethernet circuit connected to an Ethernet port. The problem is in the connection and not CTC or the node.

On TXP_MR_10G, TXP_MR_2.5G, TXPP_MR_2.5G, and MXP_2.5G_10G cards, CARLOSS is also raised against trunk ports when ITU-T G.709 encapsulation is turned off.

A TXP_MR_2.5G card can raise a CARLOSS alarm when the payload is incorrectly configured for the 10 Gigabit Ethernet or 1 Gigabit Ethernet payload data types.



Warning

Invisible laser radiation could be emitted from the end of the unterminated fiber cable or connector. Do not stare into the beam directly with optical instruments. Viewing the laser output with certain optical instruments (for example, eye loupes, magnifiers, and microscopes) within a distance of 100 mm could pose an eye hazard. Statement 1056



Warning

Use of controls, adjustments, or performing procedures other than those specified could result in hazardous radiation exposure. Statement 1057



Note

For more information about provisioning MXP or TXP PPMs (also called SFPs), refer to the “Turn Up a Node” chapter of the *Cisco ONS 15454 DWDM Procedure Guide*. For PPM (SFP) specifications, refer to the “Hardware Specifications” appendix in the *Cisco ONS 15454 DWDM Reference Manual*. For more information about MRC-12 and OC192-XFP/STM64-XFP cards, refer to the “Optical Cards” chapter in the *Cisco ONS 15454 Reference Manual*.

**Note**

For more information about Ethernet cards, refer to the *Ethernet Card Software Feature and Configuration Guide for the Cisco ONS 15454, Cisco ONS 15454 SDH, and Cisco ONS 15327*.

Clear the CARLOSS (EQPT) Alarm

- Step 1** If the reporting card is an MXP or TXP card in an ONS 15454 node, verify the data rate configured on the PPM (also called SFP):
- In node view (single-shelf mode) or shelf view (multishelf mode), double-click the reporting MXP or TXP card.
 - Click the **Provisioning > Pluggable Port Modules** tabs.
 - View the Pluggable Port Modules area port listing in the **Actual Equipment Type** column and compare this with the contents of the Selected PPM area Rate column for the MXP or TXP multirate port.
 - If the rate does not match the actual equipment, you must delete and recreate the selected PPM. Select the PPM (SFP), click **Delete**, then click **Create** and choose the correct rate for the port rate.

**Note**

For more information about provisioning PPMs (SFPs), refer to the “Turn Up a Node” chapter of the *Cisco ONS 15454 DWDM Procedure Guide*. For PPM (SFP) specifications, refer to the “Hardware Specifications” appendix in the *Cisco ONS 15454 DWDM Reference Manual*.

- Step 2** If the reporting card is an OC-N/STM-N card, verify connectivity by pinging the ONS system that is reporting the alarm by completing the “[1.6.8 Verify PC Connection to the ONS 15454 \(ping\)](#)” procedure on page 1-42.
- Step 3** If the ping is successful, it demonstrates that an active TCP/IP connection exists. Restart CTC:
- Exit from CTC.
 - Reopen the browser.
 - Log into CTC.
- Step 4** Using optical test equipment, verify that proper receive levels are achieved. (For instructions about using optical test equipment, refer to the manufacturer documentation.)

**Caution**

Always use the supplied electrostatic discharge wristband when working with a powered ONS system. Plug the wristband cable into the ESD jack located on the lower-right edge of the shelf assembly.

- Step 5** Verify that the optical LAN cable is properly connected and attached to the correct port. For more information about fiber connections and terminations, refer to the “Turn Up a Node” chapter in the *Cisco ONS 15454 DWDM Procedure Guide*.
- Step 6** If the fiber cable is properly connected and attached to the port, verify that the cable connects the card to another Ethernet device and is not misconnected to an OC-N/STM-N card.
- Step 7** If you are unable to establish connectivity, replace the fiber cable with a new known-good cable. To do this, refer to the “Turn Up a Node” chapter in the *Cisco ONS 15454 DWDM Procedure Guide*.

- Step 8** If you are unable to establish connectivity, perform standard network or LAN diagnostics. For example, trace the IP route, verify cable continuity, and troubleshoot any routers between the node and CTC. To verify cable continuity, follow site practices.
- Step 9** If the alarm does not clear, log into the Technical Support Website at <http://www.cisco.com/techsupport> for more information or call Cisco TAC (1-800-553-2447) in order to report a Service-Affecting (SA) problem.
-

2.5.45 CARLOSS (FC)

Default Severity: Major (MJ), Service-Affecting (SA)

Logical Object: FC

The Carrier Loss for Fibre Channel (FC) alarm occurs on the client port of a TXP_MR_10G, TXP_MR_10E, TXP_MR_10E_C, TXP_MR_10E_L, TXP_MR_2.5G, TXPP_MR_2.5G, MXP_MR_2.5G, MXPP_MR_2.5G, MXP_MR_10DME_C, MXP_MR_10DME_L, supporting 1-Gb Fibre Channel (FC1G), 2-Gb FC (FC2G), or 10Gb Fiber Channel (10G Fiber Channel) traffic. The loss can be due to a misconfiguration, fiber cut, or client equipment problem.



Note

For general information about MXP and TXP cards, refer to the “Card Reference” chapter in the *Cisco ONS 15454 DWDM Reference Manual*. For information about provisioning them, refer to the “Provision Transponder and Muxponder Cards” chapter in the *Cisco ONS 15454 DWDM Procedure Guide*.

Clear the CARLOSS (FC) Alarm

- Step 1** Complete the “[Clear the CARLOSS \(GE\) Alarm](#)” procedure on page 2-54.
- Step 2** If the alarm does not clear, log into the Technical Support Website at <http://www.cisco.com/techsupport> for more information or call Cisco TAC (1-800-553-2447) in order to report a Service-Affecting (SA) problem.
-

2.5.46 CARLOSS (GE)

Default Severity: Major (MJ), Service-Affecting (SA)

Logical Object: GE

The Carrier Loss for Gigabit Ethernet (GE) alarm occurs on the client port of a TXP_MR_10G, TXP_MR_10E, TXP_MR_10E_C, TXP_MR_10E_L, TXP_MR_2.5G, TXPP_MR_2.5G, MXP_MR_2.5G, MXPP_MR_2.5G, MXP_MR_10DME_C, MXP_MR_10DME_L, GE-XP, 10GE-XP, or ADM-10G cards supporting 1-Gbps or 10-Gbps traffic. The loss can be due to a misconfiguration, fiber cut, or client equipment problem.

**Note**

For general information about MXP and TXP cards, refer to the “Card Reference” chapter in the *Cisco ONS 15454 DWDM Reference Manual*. For information about provisioning them, refer to the “Provision Transponder and Muxponder Cards” chapter in the *Cisco ONS 15454 DWDM Procedure Guide*.

Clear the CARLOSS (GE) Alarm

- Step 1** Ensure that the GE client is correctly configured:
- In node view (single-shelf mode) or shelf view (multishelf mode), double-click the card to open the card view.
 - Click the **Provisioning > Pluggable Port Modules** tabs.
 - View the Pluggable Port Modules area port listing in the **Actual Equipment Type** column and compare this with the client equipment. If no PPM (SFP) is provisioned, refer to the “Turn Up a Node” chapter in the *Cisco ONS 15454 DWDM Procedure Guide*. PPM (SFP) specifications are listed in the “Hardware Specifications” appendix in the *Cisco ONS 15454 DWDM Reference Manual*.
 - If a PPM (SFP) has been created, view the contents of the Selected PPM area Rate column for the MXP or TXP MR card and compare this rate with the client equipment data rate. In this case, the rate should be ONE_GE or 10G Ethernet. If the PPM (SFP) rate is differently provisioned, select the PPM (SFP), click **Delete**, then click **Create** and choose the correct rate for the equipment type.

**Note**

For information about installing provisioning PPMs (SFPs), refer to the “Turn Up a Node” chapter in the *Cisco ONS 15454 DWDM Procedure Guide*.

- Step 2** If there is no PPM (SFP) misprovisioning, check for a fiber cut. An LOS alarm would also be present. If there is an alarm, complete the “Clear the LOS (OCN/STMN) Alarm” procedure located in Chapter 2, “Alarm Troubleshooting,” of the *Cisco ONS 15454 Troubleshooting Guide* or *Cisco ONS 15454SDH Troubleshooting Guide*.
- Step 3** If there is no fiber cut or provisioning error, check the client-side equipment for any transmission errors on the line.
- Step 4** If the alarm does not clear, log into the Technical Support Website at <http://www.cisco.com/techsupport> for more information or call Cisco TAC (1-800-553-2447) in order to report a Service-Affecting (SA) problem.

2.5.47 CARLOSS (ISC)

Default Severity: Major (MJ), Service-Affecting (SA)

Logical Object: ISC

The Carrier Loss for Inter-Service Channel (ISC) alarm occurs on the client port of a TXP_MR_10G, TXP_MR_10E, TXP_MR_10E_C, TXP_MR_10E_L, TXP_MR_2.5G, TXPP_MR_2.5G, MXP_MR_2.5G, and MXPP_MR_2.5G supporting ISC traffic. The loss can be due to a misconfiguration, fiber cut, or client equipment problem.

**Note**

For general information about MXP and TXP cards, refer to the “Card Reference” chapter in the *Cisco ONS 15454 DWDM Reference Manual*. For information about provisioning them, refer to the “Provision Transponder and Muxponder Cards” chapter in the *Cisco ONS 15454 DWDM Procedure Guide*.

Clear the CARLOSS (ISC) Alarm

-
- Step 1** Complete the “[Clear the CARLOSS \(GE\) Alarm](#)” procedure on page 2-54.
- Step 2** If the alarm does not clear, log into the Technical Support Website at <http://www.cisco.com/techsupport> for more information or call Cisco TAC (1-800-553-2447) in order to report a Service-Affecting (SA) problem.
-

2.5.48 CARLOSS (TRUNK)

Default Severity: Major (MJ), Service-Affecting (SA)

Logical Object: TRUNK

A Carrier Loss alarm is raised on the optical Trunk-RX port of a TXP_MR_10G, TXP_MR_10E, TXP_MR_10E_C, TXP_MR_10E_L, TXP_MR_2.5G, TXPP_MR_2.5G, MXP_MR_2.5G, and MXPP_MR_2.5G when the Ethernet payload is lost. This alarm only occurs when ITU-T G.709 encapsulation is disabled.

**Note**

For general information about TXP cards and their monitoring capabilities, refer to the “Card Reference” chapter in the *Cisco ONS 15454 DWDM Reference Manual*. For information about provisioning them, refer to the “Provision Transponder and Muxponder Cards” chapter in the *Cisco ONS 15454 DWDM Procedure Guide*.

Clear the CARLOSS (TRUNK) Alarm

-
- Step 1** Check for any upstream equipment failures:
- Verify that the far-end TXP or MXP is generating the signal to be received by the alarmed card.
 - Verify that the Trunk-Tx port is not reporting any performance monitoring (PM) problems.
 - Verify that the Client-Rx port is not reporting any PM problems that could cause the CARLOSS in this card.

**Note**

For more information about performance monitoring, refer to the “Performance Monitoring” chapter of the *Cisco ONS 15454 DWDM Reference Manual*.

- Step 2** If there is no cause upstream, verify cabling continuity from the transmitting port of the DWDM card (AD-xC-xx.x-xx.x, 32DMX-O, 32DMX, or 40DMX) connected to the TXP receiving port reporting this alarm.

- Step 3** If a patch panel is used, ensure that the LC-LC adapter managing the connection is in good working order.
- Step 4** If the continuity is good, clean the fiber according to site practice. If none exists, complete the fiber cleaning procedure in the “Maintain the Node” chapter in the *Cisco ONS 15454 DWDM Procedure Guide*.
- Step 5** If the signal is valid, ensure that the transmit and receive outputs from the patch panel to your equipment are properly connected (that is, the correct wavelength is coming from the patch panel). For more information about fiber connections and terminations, refer to the “Turn Up a Node” chapter in the *Cisco ONS 15454 DWDM Procedure Guide*.
- Step 6** If the correct port is in service but the alarm has not cleared, use an optical test set to confirm that a valid signal exists on the input port of the alarmed TXP. For specific procedures to use the test set equipment, consult the manufacturer. Test the line as close to the receiving card as possible.
- Step 7** If the alarm does not clear, complete the “Physically Replace a Card” procedure on page 2-244 for the reporting card.

**Warning**

Warning: High-performance devices on this card can get hot during operation. To remove the card, hold it by the faceplate and bottom edge. Allow the card to cool before touching any other part of it or before placing it in an antistatic bag. Statement 201

- Step 8** If the alarm does not clear, log into the Technical Support Website at <http://www.cisco.com/techsupport> for more information or call Cisco TAC (1-800-553-2447) in order to report a Service-Affecting (SA) problem.
-

2.5.49 CASETEMP-DEG

Default Severity: Minor (MN), Non-Service-Affecting (NSA)

Logical Object: AOTS

The Case Temperature Degrade alarm is raised when a DWDM card temperature sensor detects an out-of-range external temperature at the shelf level. The working range for DWDM cards is from 23 degrees F (–5 degrees C) to 149 degrees F (65 degrees C).

**Note**

For specific temperature and environmental information about each DWDM card, refer to the “Hardware Specifications” appendix in the *Cisco ONS 15454 DWDM Reference Manual*.

Clear the CASETEMP-DEG Alarm

- Step 1** Determine whether the air filter needs replacement. Complete the “Inspect, Clean, and Replace the Reusable Air Filter” procedure on page 2-247.
- Step 2** If the filter is clean, complete the “Remove and Reinsert a Fan-Tray Assembly” procedure on page 2-248.
- Step 3** If the fan does not run or the alarm persists, complete the “Replace the Fan-Tray Assembly” procedure on page 2-249. The fan should run immediately when correctly inserted.

- Step 4** If the alarm does not clear, log into the Technical Support Website at <http://www.cisco.com/techsupport> for more information or call Cisco TAC (1-800-553-2447).

2.5.50 CHANLOSS

Default Severity: Not Alarmed (NA), Non-Service-Affecting (NSA)

Logical Object: OCN

The SONET Section Layer DCC Termination Failure condition occurs when the ONS 15454 receives unrecognized data in the section layer DCC bytes.



Warning

Invisible laser radiation could be emitted from the end of the unterminated fiber cable or connector. Do not stare into the beam directly with optical instruments. Viewing the laser output with certain optical instruments (for example, eye loupes, magnifiers, and microscopes) within a distance of 100 mm could pose an eye hazard. Statement 1056



Warning

Use of controls, adjustments, or performing procedures other than those specified may result in hazardous radiation exposure. Statement 1057

Clear the CHANLOSS Condition

- Step 1** In the absence of other alarms, determine whether the alarmed port is connected to another vendor's equipment. If so, you can mask the alarm on this path using a custom alarm profile. For more information about custom profiles, refer to the "Manage Alarms" chapter in the *Cisco ONS 15454 Procedure Guide*.

- Step 2** If alternate vendor equipment is not the cause of the alarm, complete the "[Reset a Card in CTC](#)" procedure on [page 2-241](#) for the traffic card.



Caution

Always use the supplied electrostatic discharge wristband when working with a powered ONS 15454. Plug the wristband cable into the ESD jack located on the lower-right edge of the shelf assembly.

- Step 3** If the alarm does not clear, complete the "[Physically Replace a Card](#)" procedure on [page 2-244](#).

- Step 4** If the alarm does not clear, log into the Technical Support Website at <http://www.cisco.com/techsupport> for more information or call Cisco TAC (1-800-553-2447).

2.5.51 CLDRESTART

Default Severity: Not Alarmed (NA), Non-Service-Affecting (NSA)

Logical Object: EQPT

The Cold Restart condition occurs when a card is physically removed and inserted, replaced, or when the ONS 15454 power is initialized.

Clear the CLDRESTART Condition

-
- Step 1** Complete the [“Remove and Reinsert \(Reseat\) the Standby TCC2/TCC2P Card”](#) procedure on page 2-242.
 - Step 2** If the condition fails to clear after the card reboots, complete the [“Remove and Reinsert \(Reseat\) Any Card”](#) procedure on page 2-243.
 - Step 3** If the condition does not clear, complete the [“Physically Replace a Card”](#) procedure on page 2-244 for the card.
 - Step 4** If the condition does not clear, log into the Technical Support Website at <http://www.cisco.com/techsupport> for more information or call Cisco TAC (1-800-553-2447).
-

2.5.52 CONTBUS-DISABLED

Default Severity: Critical (CR), Service-Affecting (SA)

Logical Object: EQPT

The CONTBUS-DISABLED alarm is a function of the enhanced cell bus verification feature. This alarm occurs when a card is defective upon insertion into the chassis or when a card already present in the chassis becomes defective. (That is, the card fails the enhanced cell bus verification test.) The alarm persists as long as the defective card remains in the chassis. When the card is removed, CONTBUS-DISABLED will remain raised for a one-minute wait time. This wait time is designed as a guard period so that the system can distinguish this outage from a briefer card reset communication outage.

If no card is reinserted into the original slot during the wait time, the alarm clears. After this time, a different, nondefective card (not the original card) should be inserted.

When CONTBUS-DISABLED is raised, no message-oriented communication is allowed to or from this slot to the TCC2/TCC2P card (thus avoiding node communication failure).



Caution

CONTBUS-DISABLED clears only when the faulty card is removed for one minute. If any card at all is reinserted before the one-minute guard period expires, the alarm does not clear.

CONTBUS-DISABLED overrides the IMPROPRMVL alarm during the one-minute wait period, but afterward IMPROPRMVL can be raised because it is no longer suppressed. IMPROPRMVL is raised after CONTBUS-DISABLED clears if the card is in the node database. If CONTBUS-DISABLED has cleared but IMPROPRMVL is still active, inserting a card will clear the IMPROPRMVL alarm.

Clear the CONTBUS-DISABLED Alarm

-
- Step 1** If the IMPROPRMVL alarm is raised, complete the [“Physically Replace a Card”](#) procedure on page 2-244. (For general information about card installation, refer to the [“Install Cards and Fiber-Optic Cable”](#) chapter of the *Cisco ONS 15454 Procedure Guide*.)

- Step 2** If the condition does not clear, log into the Technical Support Website at <http://www.cisco.com/techsupport> for more information or log into <http://www.cisco.com/warp/public/687/Directory/DirTAC.shtml> to obtain a directory of toll-free Technical Support numbers for your country.
-

2.5.53 CONTBUS-IO-A

Default Severity: Minor (MN), Non-Service-Affecting (NSA)

Logical Object: EQPT

A TCCA to Shelf A Slot Communication Failure alarm occurs when the active Slot 7 TCC2/TCC2P card (TCC A) has lost communication with another card in the shelf. The other card is identified by the Object column in the CTC alarm window.

The CONTBUS-IO-A alarm can appear briefly when the ONS 15454 switches to the protect TCC2/TCC2P card. In the case of a TCC2/TCC2P card protection switch, the alarm clears after the other cards establish communication with the newly active TCC2/TCC2P card. If the alarm persists, the problem lies with the physical path of communication from the TCC2/TCC2P card to the reporting card. The physical path of communication includes the TCC2/TCC2P card, the other card, and the backplane.

Clear the CONTBUS-IO-A Alarm

- Step 1** Ensure that the reporting card is physically present in the shelf. Record the card type. Click the **Inventory** tab and view the Eqpt Type column to reveal the provisioned type.
- If the actual card type and the provisioned card type do not match, see the “[MEA \(EQPT\)](#)” alarm, [page 2-157](#) for the reporting card.
- Step 2** If the alarm object is any single card slot other than the standby Slot 11 TCC2/TCC2P card, perform a CTC reset of the object card. Complete the “[Reset a Card in CTC](#)” procedure on [page 2-241](#). For the LED behavior, see the “[2.7.2 Typical Traffic Card LED Activity During Reset](#)” section on [page 2-235](#).
- Step 3** If the alarm object is the standby Slot 11 TCC2/TCC2P card, complete the “[Reset a Card in CTC](#)” procedure on [page 2-241](#) for it. The procedure is similar.
- Wait ten minutes to verify that the card you reset completely reboots and becomes the standby card. (A reset standby card remains standby.)
- Step 4** If CONTBUS-IO-A is raised on several cards at once, complete the “[Reset an Active TCC2/TCC2P Card and Activate the Standby Card](#)” procedure on [page 2-241](#).
- Wait ten minutes to verify that the card you reset completely reboots and becomes the standby card.
- Step 5** Verify that the reset is complete and error-free and that no new related alarms appear in CTC. A green ACT/SBY LED indicates an active card. An amber ACT/SBY LED indicates a standby card.
- Step 6** If the CTC reset does not clear the alarm, complete the “[Remove and Reinsert \(Reseat\) Any Card](#)” procedure on [page 2-243](#) for the reporting card.



Caution

Always use the supplied electrostatic discharge wristband when working with a powered ONS 15454. Plug the wristband cable into the ESD jack located on the middle-right outside edge of the shelf assembly.

- Step 7** If the reset card has not rebooted successfully, or the alarm has not cleared, log into the Technical Support Website at <http://www.cisco.com/techsupport> for more information or log into <http://www.cisco.com/warp/public/687/Directory/DirTAC.shtml> to obtain a directory of toll-free TAC numbers for your country. If the Technical Support technician tells you to reseal the card, complete the [“Remove and Reinsert \(Reseat\) the Standby TCC2/TCC2P Card” procedure on page 2-242](#). If the Technical Support technician tells you to remove the card and reinstall a new one, follow the [“Physically Replace a Card” procedure on page 2-244](#).
-

2.5.54 CONTBUS-IO-B

Default Severity: Minor (MN), Non-Service-Affecting (NSA)

Logical Object: EQPT

A TCC B to Shelf Communication Failure alarm occurs when the active Slot 11 TCC2/TCC2P card (TCC B) has lost communication with another card in the shelf. The other card is identified by the Object column in the CTC alarm window.

The CONTBUS-IO-B alarm could appear briefly when the ONS 15454 switches to the protect TCC2/TCC2P card. In the case of a TCC2/TCC2P card protection switch, the alarm clears after the other cards establish communication with the newly active TCC2/TCC2P card. If the alarm persists, the problem lies with the physical path of communication from the TCC2/TCC2P card to the reporting card. The physical path of communication includes the TCC2/TCC2P card, the other card, and the backplane.

Clear the CONTBUS-IO-B Alarm

-
- Step 1** Ensure that the reporting card is physically present in the shelf. Record the card type. Click the **Inventory** tab and view the Eqpt Type column to reveal the provisioned type. If the actual card type and the provisioned card type do not match, see the [“MEA \(EQPT\)” alarm, page 2-157](#) for the reporting card.
- Step 2** If the alarm object is any single card slot other than the standby Slot 7 TCC2/TCC2P card, perform a CTC reset of the object card. Complete the [“Reset a Card in CTC” procedure on page 2-241](#). For the LED behavior, see the [“2.7.2 Typical Traffic Card LED Activity During Reset” section on page 2-235](#).
- Step 3** If the alarm object is the standby Slot 7 TCC2/TCC2P card, complete the [“Reset a Card in CTC” procedure on page 2-241](#) for it. The procedure is similar. Wait ten minutes to verify that the card you reset completely reboots and becomes the standby card. (A reset standby card remains standby.)
- Step 4** If CONTBUS-IO-B is raised on several cards at once, complete the [“Reset an Active TCC2/TCC2P Card and Activate the Standby Card” procedure on page 2-241](#). Wait ten minutes to verify that the card you reset completely reboots and becomes the standby card.
- Step 5** Verify that the reset is complete and error-free and that no new related alarms appear in CTC. A green ACT/SBY LED indicates an active card. An amber ACT/SBY LED indicates a standby card.
- Step 6** If the CTC reset does not clear the alarm, complete the [“Remove and Reinsert \(Reseat\) Any Card” procedure on page 2-243](#) for the reporting card.

**Caution**

Always use the supplied electrostatic discharge wristband when working with a powered ONS 15454. Plug the wristband cable into the ESD jack located lower-right edge of the shelf assembly.

Step 7

If the reset card has not rebooted successfully, or the alarm has not cleared, log into the Technical Support Website at <http://www.cisco.com/techsupport> for more information or log into <http://www.cisco.com/warp/public/687/Directory/DirTAC.shtml> to obtain a directory of toll-free TAC numbers for your country. If the Technical Support technician tells you to reseat the card, complete the “[Remove and Reinsert \(Reseat\) the Standby TCC2/TCC2P Card](#)” procedure on page 2-242. If the Technical Support technician tells you to remove the card and reinstall a new one, follow the “[Physically Replace a Card](#)” procedure on page 2-244.

2.5.55 CTNEQPT-MISMATCH

Default Severity: Not Alarmed (NA), Non-Service-Affecting (NSA)

Logical Object: EQPT

The Connection Equipment Mismatch condition is raised when there is a mismatch between the cross-connect card preprovisioned in the slot and the card actually present in the shelf. For example, an XC-VXL card could be preprovisioned in Slot 10, but another card could be physically installed.

**Note**

Cisco does not support configurations of unmatched cross-connect cards in Slot 8 and Slot 10, although this situation could briefly occur during the upgrade process.

**Note**

The cross-connect card you are replacing should not be the active card. (It can be in SBY state or otherwise not in use.)

**Note**

During an upgrade, this condition occurs and is raised as its default severity, Not Alarmed (NA). However, after the upgrade has occurred, if you wish to change the condition’s severity so that it is Not Reported (NR), you can do this by modifying the alarm profile used at the node. For more information about modifying alarm severities, refer to the “Manage Alarms” chapter in the *Cisco ONS 15454 Procedure Guide*.

Clear the CTNEQPT-MISMATCH Condition

Step 1

Determine what kind of card is preprovisioned in the slot by completing the following steps:

- a. In node view, click the **Inventory** tab.
- b. View the slot’s row contents in the Eqpt Type and Actual Eqpt Type columns.

The Eqpt Type column contains the equipment that is provisioned in the slot. The Actual Eqpt Type contains the equipment that is physically present in the slot. For example, Slot 8 could be provisioned for an XCVT card, which is shown in the Eqpt Type column, but a different cross-connect card could be physically present in the slot. (This card would be shown in the Actual Eqpt Type column.)

- Step 2** Complete the “[Physically Replace a Card](#)” procedure on page 2-244 for the mismatched card.
- Step 3** If the condition does not clear, log into the Technical Support Website at <http://www.cisco.com/techsupport> for more information or log into <http://www.cisco.com/warp/public/687/Directory/DirTAC.shtml> to obtain a directory of toll-free Technical Support numbers for your country.

2.5.56 DATAFLT

Default Severity: Minor (MN), Non-Service-Affecting (NSA)

Logical Object: NE

The Software Data Integrity Fault alarm occurs when the TCC2/TCC2P card exceeds its flash memory capacity.



Caution

When the system reboots, the last configuration entered is not saved.

Clear the DATAFLT Alarm

- Step 1** Complete the “[Reset an Active TCC2/TCC2P Card and Activate the Standby Card](#)” procedure on page 2-241.
- Step 2** If the alarm does not clear, log into the Technical Support Website at <http://www.cisco.com/techsupport> for more information or call Cisco TAC (1-800-553-2447).

2.5.57 DBOSYNC

Default Severity: Major (MJ), Service-Affecting (SA)

Logical Object: NE

The Standby Database Out Of Synchronization alarm occurs when the standby TCC2/TCC2P card database does not synchronize with the active database on the active TCC2/TCC2P card.



Caution

If you reset the active TCC2/TCC2P card while this alarm is raised, you lose current provisioning.

Clear the DBOSYNC Alarm

-
- Step 1** Save a backup copy of the active TCC2/TCC2P card database. Refer to the “Maintain the Node” chapter in the *Cisco ONS 15454 DWDM Procedure Guide*.
- Step 2** Make a minor provisioning change to the active database to see if applying a provisioning change clears the alarm:
- In node view (single-shelf mode) or multishelf view (multishelf mode), click the **Provisioning > General > General** tabs.
 - In the Description field, make a small change such as adding a period to the existing entry.
The change causes a database write but does not affect the node state. The write could take up to a minute.
- Step 3** If the alarm does not clear, log into the Technical Support Website at <http://www.cisco.com/techsupport> for more information or call Cisco TAC (1-800-553-2447).
-

2.5.58 DCU-LOSS-FAIL

Default Severity: Minor (MN), Non-Service-Affecting (NSA)

Logical Object: OTS

The DCU-LOSS-FAIL condition occurs when the DCU loss monitored value exceeds the board's maximum acceptable DCU loss.

Clear the DCU-LOSS-FAIL Condition

-
- Step 1** Verify that the optical fibers connecting the board (OPT-PRE, OPT-PRE-L, or OPT-AMP-L) and the DCU unit are clean, correctly plugged in, and not damaged.
- Step 2** If the condition does not clear, verify that appropriate DCU unit, according to the installation requirements, is connected to the board and is correctly working.
- Step 3** If the condition still does not clear, verify that the optical power signal is present on the DCU-TX port.
- Step 4** If the alarm is still present, log into the Technical Support Website at <http://www.cisco.com/techsupport> for more information or call Cisco TAC (1-800-553-2447).
-

2.5.59 DISCONNECTED

Default Severity: Minor (MN), Non-Service-Affecting (NSA)

Logical Object: SYSTEM

The Disconnected alarm is raised when CTC has been disconnected from the node. The alarm is cleared when CTC is reconnected to the node.

Clear the DISCONNECTED Alarm

-
- Step 1** Restart the CTC application.
- Step 2** If the alarm does not clear, log into the Technical Support Website at <http://www.cisco.com/techsupport> for more information or call TAC (1-800-553-2447).
-

2.5.60 DSP-COMM-FAIL

Default Severity: Major (MJ), Service-Affecting (SA)

Logical Object: TRUNK

The Digital Signal Processor (DSP) Communication Failure alarm indicates that there is a communication failure between an MXP or TXP card microprocessor and the on-board DSP chip that controls the trunk (or DWDM) port. This alarm typically occurs after a DSP code upgrade.

The alarm is temporary and does not require user action. The MXP or TXP card microprocessor attempts to restore communication with the DSP chip until the alarm is cleared. (For general information about MXP and TXP cards, refer to the “Card Reference” chapter of the *Cisco ONS 15454 DWDM Reference Manual*.)

If the alarm is raised for an extended period, the MXP or TXP card raises the “[DUP-IPADDR](#)” alarm on [page 2-65](#) and could affect traffic.



Note

DSP-COMM-FAIL is an informational alarm and does not require troubleshooting.

2.5.61 DSP-FAIL

Default Severity: Major (MJ), Service-Affecting (SA)

Logical Object: TRUNK

The DSP Failure alarm indicates that a “[DSP-COMM-FAIL](#)” alarm, [page 2-64](#), has persisted for an extended period on an MXP or TXP card. It indicates that the card is faulty.

Clear the DSP-FAIL Alarm

-
- Step 1** Complete the “[Physically Replace a Card](#)” procedure on [page 2-244](#) for the reporting MXP or TXP card.



Warning

Warning: High-performance devices on this card can get hot during operation. To remove the card, hold it by the faceplate and bottom edge. Allow the card to cool before touching any other part of it or before placing it in an antistatic bag. Statement 201

- Step 2** If the alarm does not clear, log into the Technical Support Website at <http://www.cisco.com/techsupport> for more information or call Cisco TAC (1-800-553-2447) in order to report a service-affecting problem.
-

2.5.62 DUP-IPADDR

Default Severity: Minor (MN), Non-Service Affecting (NSA)

Logical Object: NE

The Duplicate IP Address alarm indicates that the alarmed node IP address is already in use within the same data communications channel (DCC) area. When this happens, CTC no longer reliably connects to either node. Depending on how the packets are routed, CTC could connect to either node (having the same IP address). If CTC has connected to both nodes before they shared the same address, it has two distinct NodeModel instances (keyed by the node ID portion of the MAC address).

Clear the DUP-IPADDR Alarm

-
- Step 1** Isolate the alarmed node from the other node having the same address:
- Connect to the alarmed node using the Craft port on the TCC2/TCC2P card.
 - Begin a CTC session.
 - In the login dialog box, uncheck the **Network Discovery** check box.
- Step 2** In node view (single-shelf mode) or multishelf view (multishelf mode), click the **Provisioning > Network > General** tabs.
- Step 3** In the IP Address field, change the IP address to a unique number.
- Step 4** Click **Apply**.
- Step 5** Restart any CTC sessions that are logged into either of the duplicate IP addresses. (For procedures to log in or log out, refer to the “Connect the PC and Log Into the GUI” chapter in the *Cisco ONS 15454 DWDM Procedure Guide*.)
- Step 6** If the alarm does not clear, log into the Technical Support Website at <http://www.cisco.com/techsupport> for more information or call Cisco TAC (1-800-553-2447).
-

2.5.63 DUP-NODENAME

Default Severity: Minor (MN), Non-Service-Affecting (NSA)

Logical Object: NE

The Duplicate Node Name alarm indicates that the alarmed node alphanumeric name is already being used within the same DCC area.

Clear the DUP-NODENAME Alarm

-
- Step 1** In node view (single-shelf mode) or multishelf view (multishelf mode), click the **Provisioning > General > General** tabs.
- Step 2** In the Node Name field, enter a unique name for the node.
- Step 3** Click **Apply**.

- Step 4** If the alarm does not clear, log into the Technical Support Website at <http://www.cisco.com/techsupport> for more information or call Cisco TAC (1-800-553-2447).
-

2.5.64 DUP-SHELF-ID

Default Severity: Major (MJ), Service-Affecting (SA)

Logical Object: SHELF

The Duplicated Shelf Identifier alarm applies to a shelf that has multishelf management enabled when the TCC2/TCC2P detects that you have programmed an ID already in use by another shelf. For more information about provisioning an NC shelf or SS shelf for multishelf configurations, refer to the “Turn Up a Node” chapter in the *Cisco ONS 15454 DWDM Procedure Guide* and “Node Reference” chapter in the *Cisco ONS 15454 DWDM Reference Manual*.

Clear the DUP-SHELF-ID Alarm

- Step 1** Unprovision the shelf ID of the duplicate shelf by completing the following steps:
- In shelf view (multishelf mode) or multishelf view (multishelf mode), click the node controller **Provisioning > General > Multishelf Config** tabs.
 - Enter a new value in the **Shelf ID** field.
 - Click **Apply**.
- Step 2** If the alarm does not clear, log into the Technical Support Website at <http://www.cisco.com/techsupport> for more information or call Cisco TAC (1-800-553-2447) in order to report a Service-Affecting (SA) problem.
-

2.5.65 EHIBATVG

Default Severity: Major (MJ), Service-Affecting (SA)

Logical Object: PWR

The Extreme High Voltage Battery alarm occurs in a –48 VDC environment when a battery lead input voltage exceeds the extreme high power threshold. This threshold, with a default value of –56.5 VDC, is user-provisionable. The alarm remains raised until the voltage remains under the threshold for 120 seconds. (For information about changing this threshold, refer to the “Turn Up Node” chapter in the *Cisco ONS 15454 DWDM Procedure Guide*.)

Clear the EHIBATVG Alarm

- Step 1** The problem is external to the ONS system. Troubleshoot the power source supplying the battery leads.

- Step 2** If the alarm does not clear, log into the Technical Support Website at <http://www.cisco.com/techsupport> for more information or call Cisco TAC (1-800-553-2447) in order to report a Service-Affecting (SA) problem.
-

2.5.66 ELWBATVG

Default Severity: Major (MJ), Service-Affecting (SA)

Logical Object: PWR

The Extreme Low Voltage Battery alarm occurs in a –48 VDC environment when a battery lead input voltage falls below the extreme low power threshold. This threshold, with a default value of –40.5 VDC, is user-provisionable. The alarm remains raised until the voltage remains over the threshold for 120 seconds. (For information about changing this threshold, refer to the “Turn Up a Node” chapter in the *Cisco ONS 15454 DWDM Procedure Guide*.)

Clear the ELWBATVG Alarm

- Step 1** The problem is external to the ONS system. Troubleshoot the power source supplying the battery leads.
- Step 2** If the alarm does not clear, log into the Technical Support Website at <http://www.cisco.com/techsupport> for more information or call Cisco TAC (1-800-553-2447) in order to report a Service-Affecting (SA) problem.
-

2.5.67 ENCAP-MISMATCH-P

Default Severity: Critical (CR), Service-Affecting (SA)

Logical Object: STSTRM

The Encapsulation C2 Byte Mismatch Path alarm applies to ML-Series Ethernet cards or the CE-1000 card. It occurs when the first three following conditions are met and one of the last two is false:

- The received C2 byte is not 0x00 (unequipped).
- The received C2 byte is not a PDI value.
- The received C2 does not match the expected C2.
- The expected C2 byte is not 0x01 (equipped unspecified).
- The received C2 byte is not 0x01 (equipped unspecified).

For an ENCAP-MISMATCH-P to be raised, there is a mismatch between the received and expected C2 byte, with either the expected byte or received byte value being 0x01.

For example, an ENCAP-MISMATCH-P alarm is raised if a circuit created between two ML-Series or two CE-1000 cards has generic framing procedure (GFP) framing provisioned on one end and HDLC framing with LEX encapsulation provisioned on the other. The GFP framing card transmits and expects a C2 byte of 0x1B, while the HDLC framing card transmits and expects a C2 byte of 0x01.

A mismatch between the transmit and receive cards on any of the following parameters can cause the alarm:

- Mode (HDLC, GFP-F)
- Encapsulation (LEX, HDLC, PPP)
- CRC size (16 or 32)
- Scrambling state (on or off)

This alarm is demoted by a PLM-P condition or a PLM-V condition.

**Note**

By default, an ENCAP-MISMATCH-P alarm causes an ML-Series or CE-1000 card data link to go down. This behavior can be modified using the command line interface (CLI) command in interface configuration mode: **no pos trigger defect encap**.

**Note**

For more information about the ML-Series or CE-1000 Ethernet cards, refer to the *Ethernet Card Software Feature and Configuration Guide for the Cisco ONS 15454, Cisco ONS 15454 SDH, and Cisco ONS 15327*.

Clear the ENCAP-MISMATCH-P Alarm

-
- Step 1** Ensure that the correct framing mode is in use on the receive card:
- a. In node view, double-click the receive ML-Series or CE-1000 card to open the card view.
 - b. Click the **Provisioning > Card** tabs.
 - c. In the Mode drop-down list, ensure that the same mode (GFP or HDLC) is selected. If it is not, choose it and click **Apply**.
- Step 2** Ensure that the correct framing mode is in use on the transmit card, and that it is identical to the receiving card:
- a. In node view, double-click the transmit ML-Series or CE-1000 card to open the card view.
 - b. Click the **Provisioning > Card** tabs.
 - c. In the Mode drop-down list, ensure that the same mode (GFP or HDLC) is selected. If it is not, choose it and click **Apply**.
- Step 3** If the alarm does not clear, use the CLI to ensure that the remaining settings are correctly configured on the ML-Series or CE-1000 card:
- Encapsulation
 - CRC size
 - Scrambling state

To open the interface, click the **IOS** tab and click **Open IOS Command Line Interface (CLI)**. Refer to the *Ethernet Card Software Feature and Configuration Guide for the Cisco ONS 15454, Cisco ONS 15454 SDH, and Cisco ONS 15327* entries on all three of these topics to obtain the full configuration command sequences.

- Step 4** If the alarm does not clear, log into the Technical Support Website at <http://www.cisco.com/techsupport> for more information or call Cisco TAC (1-800-553-2447) in order to report a Service-Affecting (SA) problem.
-

2.5.68 EOC

Default Severity: Minor (MN), Non-Service-Affecting (NSA)

Logical Objects: OCN/STMN, TRUNK

The SONET DCC Termination Failure alarm occurs when the ONS system loses its DCC. Although this alarm is primarily SONET, it can apply to DWDM. For example, the OSCM card can raise this alarm on its OC-3 section overhead.

The SDCC consists of three bytes, D1 through D3, in the SONET overhead. The bytes convey information about operation, administration, maintenance, and provisioning (OAM&P). The ONS system uses the DCC on the SONET section layer to communicate network management information.



Warning

Invisible laser radiation could be emitted from the end of the unterminated fiber cable or connector. Do not stare into the beam directly with optical instruments. Viewing the laser output with certain optical instruments (for example, eye loupes, magnifiers, and microscopes) within a distance of 100 mm could pose an eye hazard. Statement 1056



Warning

Use of controls, adjustments, or performing procedures other than those specified could result in hazardous radiation exposure. Statement 1057



Note

If a circuit shows a partial state when this alarm is raised, the logical circuit is in place. The circuit is able to carry traffic when the connection issue is resolved. You do not need to delete the circuit when troubleshooting this alarm.



Note

For general information about OSCM or other DWDM cards, refer to the “Card Reference” chapter in the *Cisco ONS 15454 DWDM Reference Manual*. For information about changing their settings, refer to the “Change DWDM Card Settings” chapter in the *Cisco ONS 15454 DWDM Procedure Guide*. For more information about the SONET (ANSI) or SDH (ETSI) overhead, refer to the “SONET Topologies and Upgrades” chapter of the *Cisco ONS 15454 Procedure Guide* or the “SDH Topologies and Upgrades” chapter of the *Cisco ONS 15454 SDH Procedure Guide*.



Note

The EOC alarm is raised on the DWDM trunk in MSTP systems. Its SDH (ETSI) counterpart, MS-EOC, is not raised against the trunk port.

Clear the EOC Alarm

Step 1 If the LOS (DS1) alarm or SF-L alarm is reported, complete the appropriate troubleshooting procedure in the “Alarm Troubleshooting” chapter of the *Cisco ONS 15454 Troubleshooting Guide*.



Caution Always use the supplied electrostatic discharge wristband when working with a powered ONS system. Plug the wristband cable into the ESD jack located on the lower-right edge of the shelf assembly.

Step 2 If the alarm does not clear on the reporting node, verify the physical connections between the cards and that the fiber-optic cables are configured to carry SDCC traffic. For more information about fiber connections and terminations, refer to the “Turn Up a Node” chapter in the *Cisco ONS 15454 DWDM Procedure Guide*.

Step 3 If the physical connections are correct and configured to carry DCC traffic, ensure that both ends of the fiber span have in-service (IS or Unlocked) ports. Verify that the ACT/SBY LED on each card is green.

Step 4 When the LEDs on the cards are correctly illuminated, complete the [“Verify or Create Node Section DCC Terminations” procedure on page 2-245](#) to verify that the DCC is provisioned for the ports at both ends of the fiber span.

Step 5 Repeat [Step 4](#) at the adjacent nodes.

Step 6 If DCC is provisioned for the ends of the span, verify that the port is active and in service by completing the following steps:

- a. Confirm that the card shows a green LED in CTC or on the physical card. A green ACT/SBY LED indicates an active card. An amber ACT/SBY LED indicates a standby card.
- b. To determine whether the port is in service, in node view (single-shelf mode) or shelf view (multishelf mode), double-click the card in CTC to open the card view.
- c. In card view, click the **Provisioning > Line** tabs.
- d. Verify that the Admin State column lists the port as IS (or Unlocked).
- e. If the Admin State column lists the port as OOS,MT (or Locked,maintenance) or OOS,DSBLD (or Locked,disabled), click the column and choose **IS** , or **Unlocked**. Click **Apply**.

Step 7 For all nodes, if the card is in service, use an optical test set to determine whether signal failures are present on fiber terminations. For specific procedures to use the test set equipment, consult the manufacturer.



Caution Using an optical test set disrupts service on a card. It could be necessary to manually switch traffic carrying circuits over to a protection path. Refer to the [“2.8.2 Protection Switching, Lock Initiation, and Clearing” section on page 2-237](#) for commonly used switching procedures.

Step 8 If no signal failures exist on terminations, measure power levels to verify that the budget loss is within the parameters of the receiver. Refer to the “Hardware Specifications” appendix in the *Cisco ONS 15454 DWDM Reference Manual* for card power levels.

Step 9 If budget loss is within parameters, ensure that fiber connectors are securely fastened and properly terminated. For more information about cabling, refer to the “Turn Up a Node” chapter in the *Cisco ONS 15454 DWDM Procedure Guide*.

Step 10 If fiber connectors are properly fastened and terminated, complete the [“Reset an Active TCC2/TCC2P Card and Activate the Standby Card” procedure on page 2-241](#).

Wait ten minutes to verify that the card you reset completely reboots and becomes the standby card.

Resetting the active TCC2/TCC2P card switches control to the standby TCC2/TCC2P card. If the alarm clears when the ONS system node switches to the standby TCC2/TCC2P card, the user can assume that the previously active card is the cause of the alarm.

- Step 11** If the TCC2/TCC2P card reset does not clear the alarm, delete the problematic SDCC termination:
- From the **View menu in card view**, choose **Go to Previous View** if you have not already done so.
 - In node view (single-shelf mode) or multishelf view (multishelf mode), click the **Provisioning > Comm Channels > SDCC** tabs.
 - Highlight the problematic DCC termination.
 - Click **Delete**.
 - Click **Yes** in the Confirmation Dialog box.
- Step 12** Recreate the SDCC termination. Refer to the “Turn Up a Node” chapter of the *Cisco ONS 15454 DWDM Procedure Guide* for procedures.
- Step 13** Verify that both ends of the DCC have been recreated at the optical ports.
- Step 14** If the alarm has not cleared, call Cisco TAC (1-800-553-2447). If the Cisco TAC technician tells you to reseal the card, complete the [“Remove and Reinsert \(Reseat\) the Standby TCC2/TCC2P Card” procedure on page 2-242](#). If the Cisco TAC technician tells you to remove the card and reinstall a new one, follow the [“Physically Replace a Card” procedure on page 2-244](#).



Warning

Warning: High-performance devices on this card can get hot during operation. To remove the card, hold it by the faceplate and bottom edge. Allow the card to cool before touching any other part of it or before placing it in an antistatic bag. Statement 201

2.5.69 EOC-L

Default Severity: Minor (MN), Non-Service-Affecting (NSA) for OCN/STMN

Logical Object: TRUNK

The Line DCC (LDCC) Termination Failure alarm occurs when the ONS system loses its line data communications channel (LDCC) termination. For example, the OSCM card can raise this alarm on its OC-3 line overhead.

The LDCC consists of nine bytes, D4 through D12, in the SONET overhead. The bytes convey information about OAM&P. The ONS system uses the LDCCs on the SONET line layer to communicate network management information.



Warning

On the OC-192 card, the laser is on when the card is booted and the safety key is in the on position (labeled 1). The port does not have to be in service for the laser to be on. The laser is off when the safety key is off (labeled 0). Statement 293



Warning

Invisible laser radiation could be emitted from the end of the unterminated fiber cable or connector. Do not stare into the beam directly with optical instruments. Viewing the laser output with certain optical instruments (for example, eye loupes, magnifiers, and microscopes) within a distance of 100 mm could pose an eye hazard. Statement 1056

**Warning**

Use of controls, adjustments, or performing procedures other than those specified could result in hazardous radiation exposure. Statement 1057

**Note**

If a circuit shows a partial status when the EOC or EOC-L alarm is raised, it occurs when the logical circuit is in place. The circuit is able to carry traffic when the DCC termination issue is resolved. You do not need to delete the circuit when troubleshooting this alarm.

**Note**

For general information about OSCM or other DWDM cards, refer to the “Card Reference” chapter in the *Cisco ONS 15454 DWDM Reference Manual*. For information about changing their settings, refer to the “Change DWDM Card Settings” chapter in the *Cisco ONS 15454 DWDM Procedure Guide*. For more information about the SONET (ANSI) or SDH (ETSI) overhead, refer to the “SONET Topologies and Upgrades” chapter of the *Cisco ONS 15454 Procedure Guide* or the “SDH Topologies and Upgrades” chapter of the *Cisco ONS 15454 SDH Procedure Guide*.

Clear the EOC-L Alarm

- Step 1** Complete the [“Clear the EOC Alarm” procedure on page 2-70](#).
- Step 2** If the alarm has not cleared, call Cisco TAC (1-800-553-2447). If the Cisco TAC technician tells you to reseal the card, complete the [“Remove and Reinsert \(Reseat\) the Standby TCC2/TCC2P Card” procedure on page 2-242](#). If the Cisco TAC technician tells you to remove the card and reinstall a new one, follow the [“Physically Replace a Card” procedure on page 2-244](#).

**Warning**

Warning: High-performance devices on this card can get hot during operation. To remove the card, hold it by the faceplate and bottom edge. Allow the card to cool before touching any other part of it or before placing it in an antistatic bag. Statement 201

2.5.70 EQPT

Default Severity: Critical (CR), Service-Affecting (SA)

Logical Objects: AICI-AEP, AICI-AIE, EQPT, PPM

An Equipment Failure alarm indicates that a hardware failure has occurred on the reporting card. If the EQPT alarm occurs with a [“BKUPMEMP” alarm, page 2-49](#), refer to the procedure to clear the alarm. (Clearing a BKUPMEMP alarm also clears an EQPT alarm.)

This alarm is also invoked if a diagnostic circuit detects a card application-specific integrated circuit (ASIC) failure. In this case, if the card is part of a protection group, an APS switch occurs. If the card is the protect card, switching is inhibited and a [“PROTNA” alarm, page 2-189](#), is raised. The standby path generates a path-type alarm. For more information about provisioning PPMs (SFPs), refer to the “Turn Up a Node” chapter of the *Cisco ONS 15454 DWDM Procedure Guide*.

Clear the EQPT Alarm

-
- Step 1** If traffic is active on the alarmed port, you could need to switch traffic away from it. See the [“2.8.2 Protection Switching, Lock Initiation, and Clearing”](#) section on page 2-237 for commonly used traffic-switching procedures.
 - Step 2** Complete the [“Reset a Card in CTC”](#) procedure on page 2-241 for the reporting card.
 - Step 3** Verify that the reset is complete and error-free and that no new related alarms appear in CTC. Verify the LED status. A green ACT/SBY LED indicates an active card. An amber ACT/SBY LED indicates a standby card.
 - Step 4** If the CTC reset does not clear the alarm, complete the [“Remove and Reinsert \(Reseat\) Any Card”](#) procedure on page 2-243 for the reporting card.

**Warning**

Warning: High-performance devices on this card can get hot during operation. To remove the card, hold it by the faceplate and bottom edge. Allow the card to cool before touching any other part of it or before placing it in an antistatic bag. Statement 201

-
- Step 5** If the physical reseat of the card fails to clear the alarm, complete the [“Physically Replace a Card”](#) procedure on page 2-244 for the reporting card.
 - Step 6** If the alarm does not clear, log into the Technical Support Website at <http://www.cisco.com/techsupport> for more information or call Cisco TAC (1-800-553-2447) in order to report a Service-Affecting (SA) problem.
-

2.5.71 EQPT-DIAG

Default Severity: Critical (CR), Service-Affecting (SA)

Logical Object: EQPT

An Equipment-Diagnostic Failure alarm indicates that a software or hardware failure has occurred on the reporting card. This alarm can be raised against a traffic card or a cross-connect card.

Clear the EQPT-DIAG Alarm

-
- Step 1** If traffic is active on the alarmed card, you could need to switch traffic away from it. Refer to the [“2.8.2 Protection Switching, Lock Initiation, and Clearing”](#) section on page 2-237 for procedures.
 - Step 2** Complete the [“Remove and Reinsert \(Reseat\) Any Card”](#) procedure on page 2-243 for the alarmed card.
 - Step 3** If the alarm does not clear, complete the [“Physically Replace a Card”](#) procedure on page 2-244 if it is raised against a traffic card, or complete the [“2.8.5 Generic Signal and Circuit Procedures”](#) procedure on page 2-244 if the alarm is raised against the cross-connect card.
 - Step 4** If the alarm does not clear, log into the Technical Support Website at <http://www.cisco.com/techsupport> for more information or call Cisco TAC (1-800-553-2447).
-

2.5.72 EQPT-MISS

Default Severity: Critical (CR), Service-Affecting (SA)

Logical Object: FAN

The Replaceable Equipment or Unit Missing alarm is reported against the fan-tray assembly unit. It indicates that the replaceable fan-tray assembly is missing or is not fully inserted. It could also indicate that the ribbon cable connecting the AIP to the system board is bad.



Caution

Always use the supplied electrostatic discharge wristband when working with a powered ONS system. Plug the wristband cable into the ESD jack located on the lower-right edge of the shelf assembly.

Clear the EQPT-MISS Alarm

-
- Step 1** If the alarm is reported against the fan, verify that the fan-tray assembly is present.
 - Step 2** If the fan-tray assembly is present, complete the [“Replace the Fan-Tray Assembly” procedure on page 2-249](#).
 - Step 3** If no fan-tray assembly is present, obtain a fan-tray assembly and refer to the “Install the Fan-Tray Assembly,” procedure in the “Install the Shelf and Common Control Cards” chapter of the *Cisco ONS 15454 DWDM Procedure Guide*.
 - Step 4** If the alarm does not clear, replace the ribbon cable from the AIP to the system board with a known-good ribbon cable.
 - Step 5** If the alarm does not clear, log into the Technical Support Website at <http://www.cisco.com/techsupport> for more information or call Cisco TAC (1-800-553-2447) in order to report a Service-Affecting (SA) problem.
-

2.5.73 ERFI-P-CONN

Default Severity: Not Reported (NR), Non-Service-Affecting (NSA)

Logical Objects: STSMON, STSTRM

The Three-Bit (Enhanced) Remote Failure Indication (ERFI) Path Connectivity condition is triggered on DS-1, DS-3, or VT circuits when the [“UNEQ-P” alarm on page 2-226](#) and the [“TIM-P” alarm on page 2-223](#) are raised on the transmission signal.

Clear the ERFI-P-CONN Condition

-
- Step 1** Clear the UNEQ-P alarm. This should clear the ERFI condition.
 - Step 2** If the condition does not clear, log into the Technical Support Website at <http://www.cisco.com/techsupport> for more information or call Cisco TAC (1-800-553-2447).
-

2.5.74 ERFI-P-SRVR

Default Severity: Not Reported (NR), Non-Service-Affecting (NSA)

Logical Object: STSMON, STSTRM

The Three-Bit ERFI Path Server condition is triggered on DS-1, DS-3, or VT circuits when the “AIS-P” condition, page 2-27 or the “LOP-P” alarm on page 2-131 is raised on the transmission signal.

Clear the ERFI-P-SRVR Condition

-
- Step 1** Complete the “Clear the LOP-P Alarm” procedure on page 2-131. This should clear the ERFI condition.
- Step 2** If the condition does not clear, log into the Technical Support Website at <http://www.cisco.com/techsupport> for more information or call Cisco TAC (1-800-553-2447).
-

2.5.75 EXCCOL

Default Severity: Minor (MN), Non-Service-Affecting (NSA)

Logical Object: EQPT

The Excess Collisions on the LAN alarm indicates that too many collisions are occurring between data packets on the network management LAN, and communications between the ONS system and CTC could be affected. The network management LAN is the data network connecting the workstation running the CTC software to the TCC2/TCC2P card. The problem causing the alarm is external to the ONS system.

Troubleshoot the network management LAN connected to the TCC2/TCC2P card for excess collisions. You might need to contact the system administrator of the network management LAN to accomplish the following steps.

Clear the EXCCOL Alarm

-
- Step 1** Verify that the network device port connected to the TCC2/TCC2P card has a flow rate set to 10 Mb, half-duplex.
- Step 2** If the port has the correct flow rate and duplex setting, troubleshoot the network device connected to the TCC2/TCC2P card and the network management LAN.
- Step 3** If the alarm does not clear, log into the Technical Support Website at <http://www.cisco.com/techsupport> for more information or call Cisco TAC (1-800-553-2447).
-

2.5.76 EXT

Default Severity: Minor (MN), Non-Service-Affecting (NSA)

Logical Object: ENVALRM

A Failure Detected External to the NE alarm occurs because an environmental alarm is present. For example, a door could be open or flooding could have occurred.

Clear the EXT Alarm

-
- Step 1** In node view (single-shelf mode) or shelf view (multishelf mode), double-click the AIC-I card to open the card view.
 - Step 2** Double-click the **Maintenance > External Alarms** tabs.
 - Step 3** Follow your standard operating procedure to remedy environmental conditions that cause alarms. The alarm clears when the situation is remedied.
 - Step 4** If the alarm does not clear, log into the Technical Support Website at <http://www.cisco.com/techsupport> for more information or call Cisco TAC (1-800-553-2447).
-

2.5.77 FAILTOSW (2R, EQPT, ESCON, FC, GE, ISC, OCN/STMN, TRUNK, OTS)

Default Severity: Not Alarmed (NA), Non-Service-Affecting (NSA)

Logical Objects: 2R, EQPT, ESCON, FC, GE, ISC, OCN/STMN, TRUNK, OTS

The Failure to Switch to Protection Facility condition for MXP and TXP client ports occurs in a Y-cable protection group when a working or protect facility switches to its companion port by using a MANUAL command. For example, if you attempt to manually switch traffic from an unused protect port to an in-service working port, the switch will fail (because traffic is already present on the working port) and you will see the FAILTOSW condition.



Note

For more information about protection schemes, refer to the “Manage the Node” chapter of the *Cisco ONS 15454 DWDM Procedure Guide*.

Clear the FAILTOSW (2R, EQPT, ESCON, FC, GE, ISC, OCN/STMN, TRUNK, OTS) Condition

-
- Step 1** Look up and troubleshoot the higher-priority alarm. Clearing the higher-priority condition frees the card and clears the FAILTOSW.
 - Step 2** If the condition does not clear, replace the working card that is reporting the higher-priority alarm by following the [“Physically Replace a Card” procedure on page 2-244](#). This card is the working facility using the protect facility and not reporting FAILTOSW.

Replacing the working card that is reporting the higher-priority alarm allows traffic to revert to the working slot and the card reporting the FAILTOSW to switch to the protect card.
 - Step 3** If the condition does not clear, log into the Technical Support Website at <http://www.cisco.com/techsupport> for more information or call Cisco TAC (1-800-553-2447).
-

2.5.78 FAILTOSW (TRUNK)

Default Severity: Not Alarmed (NA), Non-Service-Affecting (NSA)

Logical Object: TRUNK

The Failure to Switch to Protection Facility condition applies to MXP and TXP trunk ports in splitter protection groups and occurs when a working or protect trunk port switches to its companion port by using a MANUAL command.

**Note**

For more information about protection schemes, refer to the “Manage the Node” chapter of the *Cisco ONS 15454 DWDM Procedure Guide*.

Clear the FAILTOSW (TRUNK) Condition

-
- Step 1** Look up and troubleshoot the higher-priority alarm. Clearing the higher-priority condition frees the card and clears the FAILTOSW.
- Step 2** If the condition does not clear, replace the working card that is reporting the higher-priority alarm by following the [“Physically Replace a Card” procedure on page 2-244](#). This card is the working facility using the protect facility and not reporting FAILTOSW.
- Replacing the working card that is reporting the higher-priority alarm allows traffic to revert to the working slot and the card reporting the FAILTOSW to switch to the protect card.
- Step 3** If the condition does not clear, log into the Technical Support Website at <http://www.cisco.com/techsupport> for more information or call Cisco TAC (1-800-553-2447).
-

2.5.79 FAILTOSW-HO

Default Severity: Not Alarmed (NA), Non-Service-Affecting (NSA)

Logical Object: VCMON-HP

The High-Order Path Failure to Switch to Protection condition occurs when a high-order path circuit fails to switch to the working or protect electrical circuit using the MANUAL command.

Clear the FAILTOSW-HO Condition

-
- Step 1** Complete the [“Clear the FAILTOSW \(2R, EQPT, ESCON, FC, GE, ISC, OCN/STMN, TRUNK, OTS\) Condition” procedure on page 2-76](#).
- Step 2** If the condition does not clear, log into the Cisco Technical Support Website at <http://www.cisco.com/techsupport> for more information or log into <http://www.cisco.com/warp/public/687/Directory/DirTAC.shtml> to obtain a directory of toll-free Technical Support numbers for your country.
-

2.5.80 FAILTOSW-PATH

Default Severity: Not Alarmed (NA), Non-Service-Affecting (NSA)

Logical Object: STSMON, VT-MON

The Fail to Switch to Protection Path condition occurs when the working circuit does not switch to the protection circuit on a path protection configuration. Common causes of the FAILTOSW-PATH alarm include a missing or defective protect port, a lockout set on one of the path protection nodes, or path-level alarms that would cause a path protection switch to fail including the “AIS-P” condition on page 2-27, the “LOP-P” alarm on page 2-131, the “SD-P” condition, page 2-202, the “SF-P” condition on page 2-206, and the “UNEQ-P” alarm on page 2-226.

The “SD-L” condition on page 2-201, or the “SF-L” condition on page 2-205 can also occur on the failed path.

Clear the FAILTOSW-PATH Condition in a Path Protection Configuration

-
- Step 1** Look up and clear the higher-priority alarm. Clearing this alarm frees the standby card and clears the FAILTOSW-PATH condition. If the “AIS-P” condition on page 2-27, the “LOP-P” alarm on page 2-131, the “UNEQ-P” alarm on page 2-226, the “SF-P” condition on page 2-206, the “SD-P” condition, page 2-202, the “SD-L” condition on page 2-201, or the “SF-L” condition on page 2-205 are also occurring on the reporting port, complete the applicable alarm clearing procedure.



Note A higher-priority alarm is an alarm raised on the working electrical card using the 1:N card protection group. The working DS-N card is reporting an alarm but not reporting a FAILTOSW condition.

- Step 2** If the condition does not clear, replace the active OC-N card that is reporting the higher-priority alarm. Complete the “Physically Replace a Card” procedure on page 2-244. Replacing the active OC-N card that is reporting the higher-priority alarm allows traffic to revert to the active slot. Reverting frees the standby card, which can then take over traffic from the card reporting the lower-priority alarm and the FAILTOSW-PATH condition.
- Step 3** If the condition does not clear, log into the Technical Support Website at <http://www.cisco.com/techsupport> for more information or call Cisco TAC (1-800-553-2447).
-

2.5.81 FAN

Default Severity: Critical (CR), Service-Affecting (SA)

Logical Object: FAN

The Fan Failure alarm indicates a problem with the fan-tray assembly. When the fan-tray assembly is not fully functional, the temperature of the ONS system can rise above its normal operating range.

The fan-tray assembly contains six fans and needs a minimum of five working fans to properly cool the shelf. However, even with five working fans, the fan-tray assembly could need replacement because a sixth working fan is required for extra protection against overheating.

**Caution**

Always use the supplied electrostatic discharge wristband when working with a powered ONS system. Plug the wristband cable into the ESD jack located on the lower-right edge of the shelf assembly.

Clear the FAN Alarm

-
- Step 1** Determine whether the air filter needs replacement. Complete the “[Inspect, Clean, and Replace the Reusable Air Filter](#)” procedure on page 2-247.
 - Step 2** If the filter is clean, complete the “[Remove and Reinsert a Fan-Tray Assembly](#)” procedure on page 2-248.
 - Step 3** If the fan does not run or the alarm persists, complete the “[Replace the Fan-Tray Assembly](#)” procedure on page 2-249. The fan should run immediately when correctly inserted.
 - Step 4** If the replacement fan-tray assembly does not operate correctly, log into the Technical Support Website at <http://www.cisco.com/techsupport> for more information or call Cisco TAC to report a Service-Affecting (SA) problem (1-800-553-2447).
-

2.5.82 FAPS

Default Severity: Not Alarmed (NA), Non-Service-Affecting (NSA)

Logical Objects: TRUNK

The Fast Automatic Protection Switching condition is applicable to GEXP/10GEXP cards. This condition occurs when the protection port, on the master card, switches from blocking to forwarding state.

Clear the FAPS Alarm

-
- Step 1** When the cause of switching disappears, the protection port switches from the forwarding to the blocking state, and the FAPS alarm clears.
 - Step 2** If the alarm does not clear even after the protection port switches back to the blocking state, log into the Technical Support Website at <http://www.cisco.com/techsupport> for more information or call Cisco TAC (1 800 553-2447).
-

2.5.83 FAPS-CONFIG-MISMATCH

Default Severity: Not Alarmed (NA), Non-Service-Affecting (NSA)

Logical Object: EQPT

The Fast Automatic Protection Switching (FAPS) Config Mismatch condition is raised when a GE-XP or 10GE-XP card that is provisioned as a master card in a FAPS ring, resets or when one of the master card's trunk port is not set to Blocking.

Clear the FAPS-CONFIG-MISMATCH Condition

-
- Step 1** Check the configuration of the master card. Ensure that at least one of the trunk ports of the master card is in the blocking state and the FAPS ring is complete.
- Step 2** If the condition does not clear, log into the Technical Support Website at <http://www.cisco.com/techsupport> for more information or call Cisco TAC (1-800-553-2447).
-

2.5.84 FC-NO-CREDITS

Default Severity: Major (MJ), Service-Affecting (SA)

Logical Objects: Client port

The Fibre Channel Distance Extension Credit Starvation alarm occurs on storage access networking (SAN) Fibre Channel/Fiber Connectivity (FICON) DWDM cards when the congestion prevents the GFP transmitter from sending frames to the DWDM card port. For example, the alarm can be raised when an operator configures a card to autodetect framing credits but the card is not connected to an interoperable FC-SW-standards-based Fibre Channel/FICON port.

FC-NO-CREDITS is raised only if transmission is completely prevented. (If traffic is slowed but still passing, this alarm is not raised.)

Clear the FC-NO-CREDITS Alarm

-
- Step 1** If the port is connected to a Fibre Channel/FICON switch, make sure it is configured for interoperation mode using the manufacturer's instructions.
- Step 2** If the port is not connected to a switch, turn off Autodetect Credits by completing the following steps:
- a. Double-click the DWDM card.
 - b. Click the **Provisioning > Port > General** tabs.
 - c. Under Admin State, click the cell and choose **OOS,MT** (or **Locked,maintenance**).
 - d. Click **Apply**.
 - e. Click the **Provisioning > Port > Distance Extension** tabs.
 - f. Uncheck the Autodetect Credits column check box.
 - g. Click **Apply**.
 - h. Click the **Provisioning > Port > General** tabs.
 - i. Under Admin State, click the cell and choose **IS** , or **Unlocked**.
 - j. Click **Apply**.
- Step 3** Program the Credits Available value based on the buffers available on the connected equipment by completing the following steps:



Note The NumCredits entry must be provisioned to a value smaller than or equal to the receive buffers or credits available on the connected equipment.

- a. Double-click the DWDM card.
- b. Click the **Provisioning > Port > Distance Extension** tabs.
- c. Enter a new value in the Credits Available column.
- d. Click **Apply**.

Step 4 If the replacement fan-tray assembly does not operate correctly, log into the Technical Support Website at <http://www.cisco.com/techsupport> for more information or call Cisco TAC to report a Service-Affecting (SA) problem (1-800-553-2447).

2.5.85 FDI

Default Severity: Not Alarmed (NA), Non-Service-Affecting (NSA)

Logical Objects: OCH, OCH-TERM, OMS, OTS, EQPT

The Forward Defect Indication (FDI) condition is part of MSTP network-level alarm correlation in R7.0. It is raised at the far end when the OCH optical payload is missing due to an optical channel signal (LOS), light (LOS-P), or optical power (OPWR-LFAIL) alarm root cause.

An LOS, LOS-P, or OPWR-LFAIL alarm on an MSTP circuit causes multiple alarms for each channel. Correlation simplifies troubleshooting by reporting a single alarm for multiple alarms having one root cause, then demoting the root alarms so that they are only visible in the Conditions window (showing their original severity.)

FDI clears when the optical channel is working on the aggregated or single-channel optical port.



Note Network-level alarm correlation is only supported for MSTP communication alarms. It is not supported for equipment alarms.

Clear the FDI Condition

Step 1 Clear the root-cause service-affecting alarm by using one of the following procedures, as appropriate:

- “Clear the LOS (OTS) Alarm” procedure on page 2-136
- “Clear the LOS (TRUNK) Alarm” procedure on page 2-137
- “Clear the LOS-P (OCH) Alarm” procedure on page 2-142
- “Clear the LOS-P (AOTS, OMS, OTS) Alarm” procedure on page 2-139
- “Clear the LOS-P (TRUNK) Alarm” procedure on page 2-146
- “Clear the OPWR-LFAIL Alarm” procedure on page 2-178

Step 2 If the condition does not clear, log into the Technical Support Website at <http://www.cisco.com/techsupport> for more information or call Cisco TAC (1-800-553-2447).

2.5.86 FE-FRCDWKSWBK-SPAN

Default Severity: Not Alarmed (NA), Non-Service-Affecting (NSA)

Logical Object: STMN

The Far End Forced Switch Back to Working–Span condition is raised on a far-end 1+1 protect port when it is Force switched to the working port.



Note

WKSWBK-type conditions apply only to nonrevertive circuits.

Clear the FE-FRCDWKSWBK-SPAN Condition

-
- Step 1** Complete the “[Clear a 1+1 Force or Manual Switch Command](#)” procedure on page 2-238 for the far-end port.
- Step 2** If the condition does not clear, log into the Technical Support Website at <http://www.cisco.com/techsupport> for more information or log into <http://www.cisco.com/warp/public/687/Directory/DirTAC.shtml> to obtain a directory of toll-free Technical Support numbers for your country.
-

2.5.87 FE-FRCDWKSWPR-SPAN

Default Severity: Not Alarmed (NA), Non-Service-Affecting (NSA)

Logical Object: STMN

The Far End Working Facility Forced to Switch to Protection Span condition occurs from a far-end node when a span on a four-fiber BLSR is forced from working to protect using the Force Span command. This condition is only visible on the network view Conditions tab. The port where the Force Switch occurred is indicated by an “F” on the network view detailed circuit map. This condition is accompanied by WKSWPR.

Clear the FE-FRCDWKSWPR-SPAN Condition

-
- Step 1** To troubleshoot an FE condition, determine which node and card link directly to the card reporting the FE alarm. For example, an FE-AIS condition from the OC-48 card in Slot 12 of Node 1 could link to the main AIS condition from an OC-48 card in Slot 6 of Node 2.
- Step 2** Log into the node that links directly to the card reporting the FE condition.
- Step 3** Clear the main alarm.
- Step 4** If the FE-FRCDWKSWPR-SPAN condition does not clear, complete the “[Clear a BLSR External Switching Command](#)” procedure on page 2-240.

- Step 5** If the condition does not clear, log into the Cisco Technical Support Website at <http://www.cisco.com/techsupport> for more information or log into <http://www.cisco.com/warp/public/687/Directory/DirTAC.shtml> to obtain a directory of toll-free Technical Support numbers for your country.
-

2.5.88 FE-MANWKSWBK-SPAN

Default Severity: Not Alarmed (NA), Non-Service-Affecting (NSA)

Logical Object: STMN

The Far End Manual Switch Back to Working—Span condition occurs when a far-end span is Manual switches back to working.



Note

WKSWBK-type conditions apply only to nonrevertive circuits.

Clear the FE-MANWKSWBK-SPAN Condition

- Step 1** To troubleshoot the FE condition, determine which node and card is linked directly to the card reporting the FE condition. For example, an FE condition on a card in Slot 12 of Node 1 could relate to a main alarm from a card in Slot 6 of Node 2.
- Step 2** Log into the node that is linked directly to the card reporting the FE condition.
- Step 3** Complete the [“Clear a BLSR External Switching Command” procedure on page 2-240](#).
- Step 4** If the condition does not clear, log into the Technical Support Website at <http://www.cisco.com/techsupport> for more information or log into <http://www.cisco.com/warp/public/687/Directory/DirTAC.shtml> to obtain a directory of toll-free Technical Support numbers for your country.
-

2.5.89 FE-MANWKSWPR-SPAN

Default Severity: Not Alarmed (NA), Non-Service-Affecting (NSA)

Logical Object: STMN

The Far-End Span Manual Switch Working Facility to Protect condition occurs when a four-fiber BLSR span is switched from working to protect at the far-end node using the Manual Span command. This condition is only visible on the network view Conditions tab and is accompanied by WKSWPR. The port where the Manual Switch occurred is indicated by an “M” on the network view detailed circuit map.

Clear the FE-MANWKSWPR-SPAN Condition

- Step 1** To troubleshoot an FE condition, determine which node and card link directly to the card reporting the FE alarm. For example, an FE condition on a card in Slot 12 of Node 1 could link to the main condition from a card in Slot 6 of Node 2.

- Step 2** Log into the node that links directly to the card reporting the FE condition.
- Step 3** Complete the “Clear a BLSR External Switching Command” alarm, page 2-240.
- Step 4** If the condition does not clear, log into the Cisco Technical Support Website at <http://www.cisco.com/techsupport> for more information or log into <http://www.cisco.com/warp/public/687/Directory/DirTAC.shtml> to obtain a directory of toll-free Technical Support numbers for your country.

2.5.90 FEC-MISM

Default Severity: Major (MJ), Service-Affecting (SA)

Logical Object: TRUNK

The Forward Error Correction (FEC) Mismatch alarm applies to all cards featuring FEC/E-FEC capability: TXP_MR_10G, TXP_MR_10E, TXP_MR_10E_C, TXP_MR_10E_L, TXP_MR_2.5G, TXPP_MR_2.5G, MXP_10G, MXP_MR_10E, ADM-10G, and OTU2_XP. FEC-MISMATCH is reported only on the card configured in Standard FEC mode or with FEC disabled. A card configured in enhanced FEC mode will report an “OTUK-LOF” alarm on page 2-181.

The alarm is related to ITU-T G.709 encapsulation and is only raised against a trunk port.



Note

For general information about MXP and TXP cards and their monitoring capabilities, refer to the “Card Reference” chapter in the *Cisco ONS 15454 DWDM Reference Manual*. For information about provisioning them, refer to the “Provision Transponder and Muxponder Cards” chapter in the *Cisco ONS 15454 DWDM Procedure Guide*.

Clear the FEC-MISM Alarm

- Step 1** In node view (single-shelf mode) or shelf view (multishelf mode), double-click the TXP_MR_10G, TXP_MR_10E, TXP_MR_10E_C, TXP_MR_10E_L, TXP_MR_2.5G, TXPP_MR_2.5G, MXP_MR_10G, MXP_MR_10E, ADM-10G, and OTU2_XP card.
- Step 2** Click the **Provisioning > OTN > OTN Lines** tabs.
- Step 3** In the FEC column, click **Enable** to activate the FEC feature. This causes a different OTN frame to be transmitted. Alternately, in the E-FEC column (TXP_MR_10E and MXP_MR_10E), click **Enable** to activate the Enhanced FEC feature.
- Step 4** Verify that the far-end card is configured the same way by repeating [Step 1](#) through [Step 3](#).
- Step 5** If the alarm does not clear, log into the Technical Support Website at <http://www.cisco.com/techsupport> for more information or call Cisco TAC (1-800-553-2447) in order to report a Service-Affecting (SA) problem.

2.5.91 FEPRLF

Default Severity: Minor (MN), Non-Service-Affecting (NSA)

Logical Object: OCN

The Far-End Protection Line Failure alarm occurs when there was an “SF (TRUNK)” condition on page 2-204 condition on the protect card’s APS channel coming into the node.

**Note**

The FEPRLF alarm occurs on the ONS 15454 only when bidirectional protection is used on optical (traffic) cards in a 1+1 protection group configuration.

Clear the FEPRLF Alarm on an BLSR

-
- Step 1** To troubleshoot the FE alarm, determine which node and card is linked directly to the card reporting the FE alarm. For example, an FE alarm or condition on a card in Slot 16 of Node 1 could relate to a main alarm from a card in Slot 16 in Node 2.
- Step 2** Log into the node that is linked directly to the card reporting the FE alarm.
- Step 3** Clear the main alarm. Refer to the appropriate alarm section in this chapter for procedures.
- Step 4** If the alarm does not clear, log into the Cisco Technical Support Website at <http://www.cisco.com/techsupport> for more information or log into <http://www.cisco.com/warp/public/687/Directory/DirTAC.shtml> to obtain a directory of toll-free Technical Support numbers for your country.
-

2.5.92 FIBERTEMP-DEG

Default Severity: Minor (MN), Non-Service-Affecting (NSA)

Logical Object: AOTS

The Fiber Temperature Degrade alarm occurs when a DWDM card internal heater-control circuit fails. Degraded temperature can cause some signal drift. The card should be replaced at the next opportunity.

**Note**

For general information about DWDM cards, refer to the “Card Reference” chapter in the *Cisco ONS 15454 DWDM Reference Manual*. For information about changing their settings, refer to the “Change DWDM Card Settings” chapter in the *Cisco ONS 15454 DWDM Procedure Guide*.

Clear the FIBERTEMP-DEG Alarm

-
- Step 1** For the alarmed card, complete the “Physically Replace a Card” procedure on page 2-244 at the next opportunity.

**Warning**

Warning: High-performance devices on this card can get hot during operation. To remove the card, hold it by the faceplate and bottom edge. Allow the card to cool before touching any other part of it or before placing it in an antistatic bag. Statement 201

- Step 2** If the alarm does not clear, log into the Technical Support Website at <http://www.cisco.com/techsupport> for more information or call Cisco TAC (1-800-553-2447).

2.5.93 FORCED-REQ

Default Severity: Not Alarmed (NA), Non-Service-Affecting (NSA)

Logical Object: EQPT, ML1000, ML100T, MLFX, STSMON, VT-MON

The Force Switch Request on Facility or Port condition occurs when you enter the Force command on a port to force traffic from a working port to a protect port or protection span (or from a protect port to a working port or span). You do not need to clear the condition if you want the Force switch to remain.

FORCED-REQ is raised for an IEEE 802.17b-based RPR span if the force was requested in the Cisco IOS CLI using the “`rpr-ieee protection request force-switch {east | west}`” command. It clears from the RPR-IEEE span when you remove the switch in the CLI. For the IEEE 802.17b-based RPR interface, FORCED-REQ is suppressed by the RPR-PASSTHR alarm. It also suppresses the following alarms:

- MAN-REQ (for an ML-Series object)
- RPR-SF
- RPR-SD
- WTR (for an ML-Series object)

Clear the FORCED-REQ Condition

-
- Step 1** Complete the “[Clear a 1+1 Force or Manual Switch Command](#)” procedure on page 2-238.
- Step 2** If the condition is raised on an IEEE 802.17b-based RPR span, enter the following command in the CLI in RPR-IEEE interface configuration mode:
- ```
router(config-if)#no rpr-ieee protection request force-switch {east | west}
```
- Step 3** If the condition does not clear, log into the Cisco Technical Support Website at <http://www.cisco.com/techsupport> for more information or log into <http://www.cisco.com/warp/public/687/Directory/DirTAC.shtml> to obtain a directory of toll-free Technical Support numbers for your country.
- 

## 2.5.94 FORCED-REQ-SPAN (2R, ESCON, FC, GE, ISC, OCN/STMN, OTS)

Default Severity: Not Alarmed (NA), Non-Service-Affecting (NSA)

Logical Objects: 2R, ESCON, FC, GE, ISC, OCN/STMN, OTS

The Force Switch Request Span condition applies to Y-cable-protected TXP configurable clients (OC-3, OC-12/STM-4, OC-48/STM-16, OC-192/STM-64, FC, ESCON, or FICON). If traffic is present on a working port and you use the FORCE command to prevent it from switching to the protect port (indicated by “FORCED TO WORKING”), FORCED-REQ-SPAN indicates this force switch. In this case, the force is affecting not only the facility, but the span.

**Note**

---

For more information about protection schemes, refer to the “Manage the Node” chapter of the *Cisco ONS 15454 DWDM Procedure Guide*.

---

## 2.5.95 FORCED-REQ-SPAN (TRUNK)

Default Severity: Not Alarmed (NA), Non-Service-Affecting (NSA)

Logical Object: TRUNK

The Force Switch Request Span condition applies to MXP and TXP trunk ports in splitter protection groups. If traffic is present on a working port and you use the FORCE command to prevent it from switching to the protect port (indicated by “FORCED TO WORKING”), FORCED-REQ-SPAN indicates this force switch. In this case, the force is affecting not only the facility, but the span.

**Note**

---

For more information about protection schemes, refer to the “Manage the Node” chapter of the *Cisco ONS 15454 DWDM Procedure Guide*.

---

## 2.5.96 FP-LINK-LOSS

Default Severity: Minor (MN), Non-Service-Affecting (NSA)

Logical Object: EQPT

The Front Port Link Loss condition occurs when a LAN cable is not connected to the front port of the TCC2/TCC2P card.

### Clear the FP-LINK-LOSS Condition

- 
- Step 1** Connect a LAN cable to the front port of the TCC2/TCC2P card.
- Step 2** If the condition does not clear, log into the Technical Support Website at <http://www.cisco.com/techsupport> for more information or call Cisco TAC (1-800-553-2447).
- 

## 2.5.97 FRCDSWTOINT

Default Severity: Not Alarmed (NA), Non-Service-Affecting (NSA)

Logical Object: NE-SREF

The Force Switch to Internal Timing condition occurs when the user issues a Force command to switch to an internal timing source.

**Note**

---

FRCDSWTOINT is an informational condition and does not require troubleshooting.

---

## 2.5.98 FRCDSWTOPRI

Default Severity: Not Alarmed (NA), Non-Service-Affecting (NSA)

Logical Objects: EXT-SREF, NE-SREF

The Force Switch to Primary Timing Source condition occurs when the user issues a Force command to switch to the primary timing source.



**Note**

---

FRCDSWTOPRI is an informational condition and does not require troubleshooting.

---

## 2.5.99 FRCDSWTOSEC

Default Severity: Not Alarmed (NA), Non-Service-Affecting (NSA)

Logical Objects: EXT-SREF, NE-SREF

The Force Switch to Second Timing Source condition occurs when the user issues a Force command to switch to the second timing source.



**Note**

---

FRCDSWTOSEC is an informational condition and does not require troubleshooting.

---

## 2.5.100 FRCDSWTOTHIRD

Default Severity: Not Alarmed (NA), Non-Service-Affecting (NSA)

Logical Objects: EXT-SREF, NE-SREF

The Force Switch to Third Timing Source condition occurs when the user issues a Force command to switch to a third timing source.



**Note**

---

FRCDSWTOTHIRD is an informational condition and does not require troubleshooting.

---

## 2.5.101 FRNGSYNC

Default Severity: Not Alarmed (NA), Non-Service-Affecting (NSA)

Logical Object: NE-SREF

The Free Running Synchronization Mode condition occurs when the reporting ONS system is in free-run synchronization mode. External timing sources have been disabled and the node is using its internal clock, or the node has lost its designated building integrated timing supply (BITS) timing source. After the 24-hour holdover period expires, timing slips could begin to occur on an ONS system node relying on an internal clock.



**Note**

---

If the ONS system is configured to operate from its internal clock, disregard the FRNGSYNC condition.

---



## Clear the FRNGSYNC Condition

- 
- Step 1** If the ONS system is configured to operate from an external timing source, verify that the BITS timing source is valid. Common problems with a BITS timing source include reversed wiring and bad timing cards. Refer to the “Timing” chapter in the *Cisco ONS 15454 Reference Manual* for more information.
- Step 2** If the BITS source is valid, clear alarms related to the failures of the primary and secondary reference sources, such as the “[SYNCPRI](#)” alarm on page 2-219 and the “[SYNCSEC](#)” alarm on page 2-220.
- Step 3** If the condition does not clear, log into the Technical Support Website at <http://www.cisco.com/techsupport> for more information or call Cisco TAC (1-800-553-2447).
- 

## 2.5.102 FSTSYNC

Default Severity: Not Alarmed (NA), Non-Service-Affecting (NSA)

Logical Object: NE-SREF

A Fast Start Synchronization Mode condition occurs when the node is choosing a new timing reference. The previous timing reference has failed.

The FSTSYNC alarm disappears after approximately 30 seconds. If the condition does not clear, log into the Technical Support Website at <http://www.cisco.com/techsupport> for more information or call Cisco TAC (1-800-553-2447).



**Note**

FSTSYNC is an informational condition. It does not require troubleshooting.

---

## 2.5.103 FTA-MISMATCH

Default Severity: Not Alarmed (NA), Non-Service-Affecting (NSA)

Logical Object: EQPT

The Fan Tray Mismatch condition is raised on the ADM-10G card and OTU2\_XP. It indicates that an unsupported version of the fan tray assembly (15454-FTA3 or 15454-FTA2) is installed in the shelf. The ADM-10G and OTU2\_XP card must be installed in a shelf that has FTA version 4 or higher.

## Clear the FTA-MISMATCH Condition

- 
- Step 1** Obtain the correct fan tray assembly (15454-FTA4 or higher), and replace the existing FTA with the new one by following the “[Replace the Fan-Tray Assembly](#)” procedure on page 2-249.
- Step 2** If the condition does not clear, log into the Technical Support Website at <http://www.cisco.com/techsupport> for more information or call Cisco TAC (1-800-553-2447).
-

## 2.5.104 GAIN-HDEG

Default Severity: Minor (MN), Non-Service-Affecting (NSA)

Logical Object: AOTS

The Gain High Degrade alarm is raised on an amplifier card (OPT-BST, OPT-PRE, or OPT-AMP-x-C) when the amplifier reaches the Gain High Degrade Threshold. (This value is automatically provisioned with the gain setpoint, but the alarm threshold is 2 dBm higher than the setpoint. The card should be replaced at the first opportunity.



### Note

This alarm is applicable only when the amplifier working mode is set to Control Gain.



### Note

For general information about DWDM amplifier cards, refer to the “Card Reference” chapter in the *Cisco ONS 15454 DWDM Reference Manual*. For information about control gain, refer to the “Node Reference” chapter in the same manual. For information about changing their settings, refer to the “Change DWDM Card Settings” chapter in the *Cisco ONS 15454 DWDM Procedure Guide*.

## Clear the GAIN-HDEG Alarm

- Step 1** Verify that the LED is correctly illuminated on the physical card. A green ACT/SBY LED indicates an active card. A red ACT/SBY LED indicates a failed card.
- Step 2** Complete [“Reset a Card in CTC” procedure on page 2-241](#) on the failing amplifier.
- Step 3** If the alarm does not clear, identify all the OCHNC circuits applying to the failing card. Force all the protected circuits on the optical path that the faulty amplifier does not belong to. Switch the OCHNC administrative state of all these circuits to **OOS,DSBLD** (or **Locked,disabled**).



### Caution

All remaining unprotected circuits will suffer for a traffic hit when you disable the circuits.

- Step 4** Switch the administrative state of only one of the OCHNC circuits to **IS,AINS** (or **Unlocked,automaticInService**). This forces the amplifier to recalculate its gain setpoint and value.
- Step 5** If the alarm does not clear and no other alarms exist that could be the source of the GAIN-HDEG alarm, or if clearing an alarm did not clear the GAIN-HDEG, place all of the card ports in **OOS,DSBLD** (or **Locked,disabled**) administrative state.
- Step 6** Complete the [“Physically Replace a Card” procedure on page 2-244](#) for the reporting card.



### Warning

**Invisible laser radiation may be emitted from the end of the unterminated fiber cable or connector. Do not view directly with optical instruments. Viewing the laser output with certain optical instruments (for example, eye loupes, magnifiers, and microscopes) within a distance of 100 mm may pose an eye hazard. Statement 1056**



### Warning

**Warning: High-performance devices on this card can get hot during operation. To remove the card, hold it by the faceplate and bottom edge. Allow the card to cool before touching any other part of it or before placing it in an antistatic bag. Statement 201**



---

**Note** Before disconnecting any optical amplifier card fiber for troubleshooting, ensure that the optical amplifier card is unplugged.

---

**Step 7** If the alarm does not clear, log into the Technical Support Website at <http://www.cisco.com/techsupport> for more information or call Cisco TAC (1-800-553-2447).

---

## 2.5.105 GAIN-HFAIL

Default Severity: Critical (CR), Service-Affecting (SA)

Logical Object: AOTS

The Gain High Degrade alarm is raised on an amplifier card (OPT-BST, OPT-PRE, or OPT-AMP-x-C) when the amplifier reaches the Gain High Degrade Threshold. (This value is automatically provisioned with the gain setpoint, but the alarm threshold is 5 dBm higher than the setpoint.) If the alarm cannot be cleared, the card must be replaced.



---

**Note** This alarm is applicable only when the amplifier working mode is set to Control Gain.

---



---

**Note** For general information about DWDM cards, refer to the “Card Reference” chapter in the *Cisco ONS 15454 DWDM Reference Manual*. For information about control gain, refer to the “Node Reference” chapter in the same manual. For information about changing their settings, refer to the “Change DWDM Card Settings” chapter in the *Cisco ONS 15454 DWDM Procedure Guide*.

---

### Clear the GAIN-HFAIL Alarm

---

**Step 1** For the alarmed card, complete the “[Clear the GAIN-HDEG Alarm](#)” procedure on page 2-90.

**Step 2** If the alarm does not clear, log into the Technical Support Website at <http://www.cisco.com/techsupport> for more information or call Cisco TAC (1-800-553-2447) to report a Service-Affecting (SA) problem.

---

## 2.5.106 GAIN-LDEG

Default Severity: Minor (MN), Non-Service-Affecting (NSA)

Logical Object: AOTS

The Gain High Degrade alarm is raised on an amplifier card (OPT-BST, OPT-PRE, or OPT-AMP-x-C) when the amplifier does not reach Gain High Degrade Threshold. (This value is automatically provisioned with the gain setpoint, but the alarm threshold is 2 dBm lower than the setpoint.) The card should be replaced at the first opportunity.



---

**Note** This alarm is applicable only when the amplifier working mode is set to Control Gain.

---

**Note**

For general information about DWDM amplifier cards, refer to the “Card Reference” chapter in the *Cisco ONS 15454 DWDM Reference Manual*. For information about control gain, refer to the “Node Reference” chapter in the same manual. For information about changing their settings, refer to the “Change DWDM Card Settings” chapter in the *Cisco ONS 15454 DWDM Procedure Guide*.

## Clear the GAIN-LDEG Alarm

- 
- Step 1** For the alarmed card, complete the “[Clear the GAIN-HDEG Alarm](#)” procedure on page 2-90.
- Step 2** If the alarm does not clear, log into the Technical Support Website at <http://www.cisco.com/techsupport> for more information or call Cisco TAC (1-800-553-2447).
- 

## 2.5.107 GAIN-LFAIL

Default Severity: Critical (CR), Service-Affecting (SA)

Logical Object: AOTS

The Gain High Degrade alarm is raised on an amplifier card (OPT-BST, OPT-PRE, or OPT-AMP-x-C) when the amplifier does not reach Gain High Degrade Threshold. (This value is automatically provisioned with the gain setpoint, but the alarm threshold is 5 dBm lower than the setpoint. If the alarm cannot be cleared, the card must be replaced.

**Note**

This alarm is applicable only when the amplifier working mode is set to Control Gain.

**Note**

For general information about DWDM amplifier cards, refer to the “Card Reference” chapter in the *Cisco ONS 15454 DWDM Reference Manual*. For information about control gain, refer to the “Node Reference” chapter in the same manual. For information about changing their settings, refer to the “Change DWDM Card Settings” chapter in the *Cisco ONS 15454 DWDM Procedure Guide*.

## Clear the GAIN-LFAIL Alarm

- 
- Step 1** For the alarmed card, complete the “[Clear the GAIN-HDEG Alarm](#)” procedure on page 2-90.
- Step 2** If the alarm does not clear, log into the Technical Support Website at <http://www.cisco.com/techsupport> for more information or call Cisco TAC (1-800-553-2447).
- 

## 2.5.108 GCC-EOC

Default Severity: Minor (MN), Non-Service-Affecting (NSA)

Logical Object: TRUNK, EQPT

The GCC Embedded Operation Channel Failure alarm applies to the optical transport network (OTN) communication channel for TXP\_MR\_10G, TXP\_MR\_2.5G, TXPP\_MR\_2.5G, TXP\_MR\_10E, TXP\_MR\_10E\_C, TXP\_MR\_10E\_L, MXP\_2.5G\_10G, MXP\_2.5G\_10E, ADM-10G, and OTU2\_XP cards. The GCC-EOC alarm is raised when the channel cannot operate.

This alarm applies to trunk ports only when ITU-T G.709 encapsulation is enabled and a general communication channel (GCC) has been provisioned between the two TXP/MXP cards.

**Note**

For more information about GCC circuits, please refer to the “Create Channels and Circuits” chapter in the *Cisco ONS 15454 DWDM Procedure Guide*.

## Clear the GCC-EOC Alarm

- 
- Step 1** Complete the “[Clear the EOC Alarm](#)” procedure on page 2-70.
  - Step 2** If the alarm does not clear, log into the Technical Support Website at <http://www.cisco.com/techsupport> for more information or call Cisco TAC (1-800-553-2447).
- 

## 2.5.109 GE-OOSYNC (FC, GE, ISC)

Default Severity: Critical (CR), Service-Affecting (SA)

Logical Objects: FC, GE, ISC

The Gigabit Ethernet Out of Synchronization alarm applies to TXP\_MR\_10G, TXP\_MR\_10E, TXP\_MR\_10E\_C, TXP\_MR\_10E\_L, TXP\_MR\_2.5G, TXPP\_MR\_2.5G, MXP\_MR\_2.5G, MXPP\_MR\_2.5G, GE-XP, 10GE, and ADM-10G cards when the Ethernet signal incoming on the Client-Rx port is out of synchronization.

**Note**

For general information about MXP and TXP cards, refer to the “Card Reference” chapter in the *Cisco ONS 15454 DWDM Reference Manual*. For information about provisioning them, refer to the “Provision Transponder and Muxponder Cards” chapter in the *Cisco ONS 15454 DWDM Procedure Guide*.

## Clear the GE-OOSYNC (FC, GE, ISC) Alarm

- 
- Step 1** Ensure that the incoming signal from the Client-Rx port is provisioned with the correct physical-layer protocol (Ethernet).
  - Step 2** Ensure that the line is provisioned with the correct line speed (10G or 1G Ethernet).
  - Step 3** Verify that the optical power and the optical signal-to-noise range (OSNR) of the incoming Client-Rx port optical signal are within the accepted ranges. You can find XFP/SFP ranges in the “Hardware Specifications” appendix of the *Cisco ONS 15454 DWDM Reference Manual*.

- Step 4** If the alarm does not clear, log into the Technical Support Website at <http://www.cisco.com/techsupport> for more information or call Cisco TAC (1-800-553-2447) in order to report a Service-Affecting (SA) problem.

## 2.5.110 GE-OOSYNC (TRUNK)

Default Severity: Critical (CR), Service-Affecting (SA)

Logical Objects: TRUNK

The Gigabit Ethernet Out of Synchronization alarm applies to TXP\_MR\_10G, TXP\_MR\_10E, TXP\_MR\_10E\_C, TXP\_MR\_10E\_L, TXP\_MR\_2.5G, TXPP\_MR\_2.5G, MXP\_MR\_2.5G, MXPP\_MR\_2.5G, GE-XP, 10GE, and ADM-10G cards only when the ITU-T G.709 encapsulation framer is disabled.



**Note**

For general information about MXP and TXP cards, refer to the “Card Reference” chapter in the *Cisco ONS 15454 DWDM Reference Manual*. For information about provisioning them, refer to the “Provision Transponder and Muxponder Cards” chapter in the *Cisco ONS 15454 DWDM Procedure Guide*.

## Clear the GE-OOSYNC (TRUNK) Alarm

- Step 1** Verify that ITU-T G.709 encapsulation is disabled:
- In node view (single-shelf mode) or shelf view (multishelf mode), double-click the card to display the card view.
  - Click the **Provisioning > OTN > OTN Lines** tabs.
  - If the G.709 OTN column says Enable, choose **Disable** from the drop-down list.
  - Click **Apply**.
- Step 2** For the TRUNK-RX port, double-click the card and click the **Performance > OTN PM > FEC PM** tabs. If post-FEC errors are present, troubleshoot this problem first. If not, move to next step.
- Step 3** Verify the status of far-end TXP/MXP connected to the faulty near-end card. Look for any alarms reported by the Client-Rx port of far-end card. If these alarms exist, troubleshoot them.
- Step 4** If the alarm does not clear, log into the Technical Support Website at <http://www.cisco.com/techsupport> for more information or call Cisco TAC (1-800-553-2447) in order to report a Service-Affecting (SA) problem.

## 2.5.111 GFP-CSF

Default Severity: Major (MJ), Service-Affecting (SA)

Logical Object: CEMR, CE1000, CE100T, FCMR, GFP-FAC, ML1000, ML100T, MLFX

The GFP Client Signal Fail Detected alarm is a secondary alarm raised on local GFP data ports when a remote Service-Affecting (SA) alarm causes invalid data transmission. The alarm is raised locally on CE-100T-8, CE-1000-4, CE-MR-10, FC\_MR-4, ML100T, ML1000, ML100X-8, ML-MR-10, MXP\_MR\_25G, and MXPP\_MR\_25G GFP data ports and does not indicate that a Service-Affecting (SA) failure is occurring at the local site, but that a CARLOSS, LOS, or SYNCLOSS alarm caused by an event such as a pulled receive cable is affecting a remote data port's transmission capability. This alarm can be demoted when a facility loopback is placed on the FC\_MR-4 port.

**Note**

For more information about provisioning MXP or TXP cards, refer to the *Cisco ONS 15454 DWDM Reference Manual*. For more information about Ethernet cards, refer to the *Ethernet Card Software Feature and Configuration Guide for the Cisco ONS 15454*, *Cisco ONS 15454 SDH*, and *Cisco ONS 15327*.

## Clear the GFP-CSF Alarm

- 
- Step 1** Clear the Service-Affecting (SA) alarm at the remote data port.
- Step 2** If the GFP-CSF alarm does not clear, log into the Technical Support Website at <http://www.cisco.com/techsupport> for more information or call Cisco TAC (1-800-553-2447) to report a Service-Affecting (SA) problem.
- 

## 2.5.112 GFP-LFD

Default Severity: Major (MJ), Service-Affecting (SA)

Logical Object: CEMR, CE1000, CE100T, FCMR, GFP-FAC, ML1000, ML100T, MLFX

The GFP Loss of Frame Delineation alarm applies to Fibre Channel, FICON GFP, and Ethernet ports. This alarm occurs if there is a faulty SONET connection, if SONET path errors cause GFP header errors in the check sum calculated over payload length (PLI/cHEC) combination, or if the GFP source port sends an invalid PLI/cHEC combination. This loss causes traffic stoppage.

**Note**

For more information about Ethernet cards, refer to the *Ethernet Card Software Feature and Configuration Guide for the Cisco ONS 15454*, *Cisco ONS 15454 SDH*, and *Cisco ONS 15327*.

## Clear the GFP-LFD Alarm

- 
- Step 1** Look for and clear any associated SONET path errors such as LOS or the “AU-AIS” alarm on page 2-38 that originate at the transmit node.
- Step 2** If the GFP-LFD alarm does not clear, log into the Technical Support Website at <http://www.cisco.com/techsupport> for more information or call Cisco TAC (1-800-553-2447) to report a Service-Affecting (SA) problem.
-

## 2.5.113 GFP-UP-MISMATCH

Default Severity: Major (MJ), Service-Affecting (SA)

Logical Object: CEMR, CE1000, CE100T, FCMR, GFP-FAC, ML1000, ML100T, MLFX

The GFP User Payload Mismatch is raised against Fibre Channel/FICON ports supporting GFP. It occurs when the received frame user payload identifier (UPI) does not match the transmitted UPI and all frames are dropped. The alarm is caused by a provisioning error, such as the port media type not matching the remote port media type. For example, the local port media type could be set to Fibre Channel—1 Gbps ISL or Fibre Channel—2 Gbps ISL and the remote port media type could be set to FICON—1 Gbps ISL or FICON—2 Gbps ISL.



### Note

For more information about Ethernet cards, refer to the *Ethernet Card Software Feature and Configuration Guide for the Cisco ONS 15454, Cisco ONS 15454 SDH, and Cisco ONS 15327*.

### Clear the GFP-UP-MISMATCH Alarm

- 
- Step 1** Ensure that the transmit port and receive port are identically provisioned for distance extension by completing the following steps:
- Double-click the card to open the card view.
  - Click the **Provisioning > Port > Distance Extension** tabs.
  - Check the check box in the **Enable Distance Extension** column.
  - Click **Apply**.
- Step 2** Ensure that both ports are set for the correct media type. For each port, complete the following steps:
- Double-click the card to open the card view (if you are not already in card view).
  - Click the **Provisioning > Port > General** tabs.
  - Choose the correct media type (**Fibre Channel - 1Gbps ISL**, **Fibre Channel - 2 Gbps ISL**, **FICON - 1 Gbps ISL**, or **FICON - 2 Gbps ISL**) from the drop-down list.
  - Click **Apply**.
- Step 3** If the GFP-UP-MISMATCH alarm does not clear, log into the Technical Support Website at <http://www.cisco.com/techsupport> for more information or call Cisco TAC (1-800-553-2447) to report a Service-Affecting (SA) problem.
- 

## 2.5.114 HELLO

Default Severity: Minor (MN), Non-Service-Affecting (NSA)

Logical Object: OCN

The Open Shortest Path First (OSPF) Hello alarm is raised when the two end nodes cannot bring an OSPF neighbor up to the full state. Typically, this problem is caused by an area ID mismatch, and/or OSPF HELLO packet loss over the DCC.



## Clear the HELLO Alarm

- 
- Step 1** Ensure that the area ID is correct on the missing neighbor by completing the following steps:
- In node view, click the **Provisioning > Network > OSPF** tabs.
  - Ensure that the IP address in the Area ID column matches the other nodes.
  - If the address does not match, click the incorrect cell and correct it.
  - Click **Apply**.
- Step 2** If the alarm does not clear, log into the Technical Support Website at <http://www.cisco.com/techsupport> for more information or log into <http://www.cisco.com/warp/public/687/Directory/DirTAC.shtml> to obtain a directory of toll-free Technical Support numbers for your country.
- 

## 2.5.115 HIBATVG

Default Severity: Major (MJ), Service-Affecting (SA)

Logical Object: PWR

The High Voltage Battery alarm occurs in a –48 VDC environment when a battery lead input voltage exceeds the high power threshold. This threshold, with a default value of –52 VDC, is user-provisionable. The alarm remains raised until the voltage remains under the threshold for 120 seconds.

## Clear the HIBATVG Alarm

- 
- Step 1** The problem is external to the ONS system. Troubleshoot the power source supplying the battery leads.
- Step 2** If the alarm does not clear, log into the Technical Support Website at <http://www.cisco.com/techsupport> for more information or call Cisco TAC (1-800-553-2447) in order to report a Service-Affecting (SA) problem.
- 

## 2.5.116 HI-CCVOLT

Default Severity: Not Alarmed (NA), Non-Service-Affecting (NSA)

Logical Object: BITS

The 64K Composite Clock High NE Voltage alarm occurs when the 64K signal peak voltage exceeds 1.1 VDC.

## Clear the HI-CCVOLT Condition

- 
- Step 1** Lower the source voltage to the clock.
- Step 2** If the condition does not clear, add more cable length or add a 5 dBm attenuator to the cable.

- Step 3** If the alarm does not clear, log into the Technical Support Website at <http://www.cisco.com/techsupport> for more information or call Cisco TAC (1-800-553-2447) in order to report a Service-Affecting (SA) problem.

## 2.5.117 HI-LASERBIAS

Default Severity: Minor (MN), Non-Service-Affecting (NSA)

Logical Objects: 2R, EQPT, ESCON, FC, GE, ISC, OCN/STMN, PPM, TRUNK

The Equipment High Transmit Laser Bias Current alarm is raised against TXP\_MR\_10G, TXP\_MR\_2.5G, TXPP\_MR\_2.5G, TXP\_MR\_10E, TXP\_MR\_10E\_C, TXP\_MR\_10E\_L, MXP\_2.5G\_10G, OC192-XFP, ADM-10G, and OTU2\_XP card laser performance. The alarm indicates that the card laser has reached the maximum laser bias tolerance.

Laser bias typically starts at about 30 percent of the manufacturer maximum laser bias specification and increases as the laser ages. If the HI-LASERBIAS alarm threshold is set at 100 percent of the maximum, the laser usability has ended. If the threshold is set at 90 percent of the maximum, the card is still usable for several weeks or months before it needs to be replaced.



### Note

For general information about MXP and TXP cards, refer to the “Card Reference” chapter in the *Cisco ONS 15454 DWDM Reference Manual*. Specific hardware values are listed in the “Hardware Specifications” appendix of the same manual.

## Clear the HI-LASERBIAS Alarm

- Step 1** Complete the “[Physically Replace a Card](#)” procedure on page 2-244. Replacement is not urgent and can be scheduled during a maintenance window.



### Warning

**Warning: High-performance devices on this card can get hot during operation. To remove the card, hold it by the faceplate and bottom edge. Allow the card to cool before touching any other part of it or before placing it in an antistatic bag. Statement 201**



### Caution

Removing an active card can cause a traffic hit. To avoid this, perform an external switch if a switch has not already occurred. See the “[2.8.2 Protection Switching, Lock Initiation, and Clearing](#)” section on page 2-237 for commonly used traffic-switching procedures.

- Step 2** If the alarm does not clear, log into the Technical Support Website at <http://www.cisco.com/techsupport> for more information or call Cisco TAC (1-800-553-2447).

## 2.5.118 HI-LASERTEMP

Default Severity: Minor (MN), Non-Service-Affecting (NSA)

Logical Objects: EQPT, OCN/STMN, PPM

The Equipment High Laser Optical Transceiver Temperature alarm applies to the TXP, MXP, and ADM-10G cards. HI-LASERTEMP occurs when the internally measured transceiver temperature exceeds the card setting by 35.6 degrees F (2 degrees C). A laser temperature change affects the transmitted wavelength.

When the TXP or MXP card raises this alarm, the laser is automatically shut off. The LOS (OCN/STMN) alarm is raised at the far-end node and the “DUP-IPADDR” alarm, page 2-65, is raised at the near end. (For instructions to clear either of these alarms, you can also refer to the “Alarm Troubleshooting” chapter in the *Cisco ONS 15454 Troubleshooting Guide* or *Cisco ONS 15454SDH Troubleshooting Guide*.)

**Note**

For information about MXP and TXP cards and PPMs (SFPs), refer to the “Card Reference” chapter in the *Cisco ONS 15454 DWDM Reference Manual*. For information about provisioning them, refer to the “Turn Up a Node” chapter in the *Cisco ONS 15454 DWDM Procedure Guide*.

## Clear the HI-LASERTEMP Alarm

- Step 1** In node view (single-shelf mode) or shelf view (multishelf mode), double-click the TXP or MXP card to open the card view.
- Step 2** Click the **Performance > Optics PM > Current Values** tabs.
- Step 3** Verify the card laser temperature levels. Maximum, minimum, and average laser temperatures are shown in the Current column entries in the Laser Temp rows.
- Step 4** Complete the “Reset a Card in CTC” procedure on page 2-241 for the MXP or TXP card.
- Step 5** If the alarm does not clear, complete the “Physically Replace a Card” procedure on page 2-244 for the reporting MXP or TXP card.
- Step 6** If the alarm does not clear, log into the Technical Support Website at <http://www.cisco.com/techsupport> for more information or call Cisco TAC (1-800-553-2447).

## 2.5.119 HI-RXPOWER

Default Severity: Minor (MN), Non-Service-Affecting (NSA)

Logical Objects: 2R, ESCON, FC, GE, ISC, OCN/STMN, TRUNK, EQPT

The Equipment High Receive Power alarm is an indicator of the optical signal power that is transmitted to the TXP\_MR\_10G, TXP\_MR\_2.5G, TXPP\_MR\_2.5G, TXP\_MR\_10E, TXP\_MR\_10E\_C, TXP\_MR\_10E\_L, MXP\_2.5G\_10G, OC192-XFP, GE-XP, 10GE-XP, ADM-10G, or OTU2\_XP card. HI-RXPOWER occurs when the measured optical power of the received signal exceeds the threshold. The threshold value is user-provisionable.

**Note**

For general information about MXP and TXP cards and their power levels, refer to the “Card Reference” chapter in the *Cisco ONS 15454 DWDM Reference Manual*. For information about provisioning them, refer to the “Provision Transponder and Muxponder Cards” chapter in the *Cisco ONS 15454 DWDM Procedure Guide*.

## Clear the HI-RXPOWER Alarm

- 
- Step 1** Check the PM of the TRUNK-RX port. Verify that received power is above the optics threshold:
- In node view (single-shelf mode) or shelf view (multishelf mode), double-click the card to display the card view.
  - For the TRUNK-RX port, double-click the card and click the **Performance > Optics PM > Historical PM** tabs, choose the port in the **Port** drop-down list, and click **Refresh**.
  - Compare the refreshed PM values with the threshold (ensuring that it is above the threshold value) by clicking the **Performance > Optics PM > Current Values** tabs.
  - Ensure that a proper threshold has been provisioned for the receive value. (Refer to the “Provision Transponder and Muxponder Cards” chapter in the *Cisco ONS 15454 DWDM Procedure Guide*.) If an incorrect threshold has been set, adjust it to a value within the allowed limits. If instead the alarm condition does not clear, move to next step.
- Step 2** Verify that the Trunk-Rx port is cabled correctly, and clean the fiber connecting the faulty TXP/MXP to the Drop port of the DWDM card (32DMX, 32DMX-O, 40DMX, or AD-xC-xx.x). If no site cleaning practices are available, refer to the fiber cleaning procedure in the “Maintain the Node” chapter of the *Cisco ONS 15454 DWDM Procedure Guide*.
- Step 3** Determine whether a bulk attenuator is specified by the Cisco TransportPlanner (MP) design. If so, verify that the proper fixed attenuation value has been used.
- Step 4** Using a test set, check the optical power value of the Drop port of the DWDM card (32DMX, 32DMX-O, 40DMX, or AD-xC-xx.x) connected to the faulty TXP/MXP. If the read value is different (+1 dBm or -1 dBm) from the ANS setpoint for “Padd&drop-Drop power,” move to next step.
- Step 5** Look for and troubleshoot any alarm reported by the DWDM cards belonging to the OCHNC circuit destinating at the faulty TXP/MXP. Possible alarms include amplifier Gain alarms (the “GAIN-HDEG” alarm on page 2-90, the “GAIN-HFAIL” alarm on page 2-91, the “GAIN-LDEG” alarm on page 2-91, or “GAIN-LFAIL” alarm on page 2-92); APC alarms (“APC-CORR-SKIPPED” alarm on page 2-29 or “APC-OUT-OF-RANGE” alarm on page 2-31), or LOS-P alarms on the Add or Drop ports involved in the OCHNC circuit.
- Step 6** If the alarm does not clear, log into the Technical Support Website at <http://www.cisco.com/techsupport> for more information or call Cisco TAC (1-800-553-2447).
- 

## 2.5.120 HITEMP

Default Severity: Critical (CR), Service-Affecting (SA) for NE; Default Severity: Minor (MN), Non-Service-Affecting (NSA) for EQPT

Logical Objects: EQPT, NE

The High Temperature alarm occurs when the temperature of the ONS system is above 122 degrees F (50 degrees C).

## Clear the HITEMP Alarm

- 
- Step 1** View the temperature displayed on the ONS system LCD front panel. For example, the ONS 15454 front panel is illustrated in [Figure 2-2](#).

Figure 2-2 Shelf LCD Panel

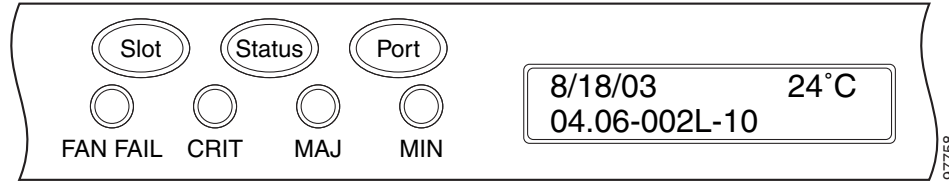

- Step 2** Verify that the environmental temperature of the room is not abnormally high.
- Step 3** If the room temperature is not abnormal, physically ensure that nothing prevents the fan-tray assembly from passing air through the ONS system shelf.
- Step 4** If airflow is not blocked, physically ensure that blank faceplates fill the ONS system shelf empty slots. Blank faceplates help airflow.
- Step 5** If faceplates fill the empty slots, determine whether the air filter needs replacement. Refer to the [“Inspect, Clean, and Replace the Reusable Air Filter” procedure on page 2-247](#).
- Step 6** If the fan does not run or the alarm persists, complete the [“Replace the Fan-Tray Assembly” procedure on page 2-249](#).



**Note** The fan should run immediately when correctly inserted.

- Step 7** If the replacement fan-tray assembly does not operate correctly, log into the Technical Support Website at <http://www.cisco.com/techsupport> for more information or call Cisco TAC to report a Service-Affecting (SA) problem (1-800-553-2447) if it applies to the NE, or a Non-Service-Affecting (NSA) problem if it applies to equipment.

## 2.5.121 HI-TXPOWER

Default Severity: Minor (MN), Non-Service-Affecting (NSA)

Logical Objects: 2R, EQPT, ESCON, FC, GE, ISC, OCN/STMN, PPM, TRUNK

The Equipment High Transmit Power alarm is an indicator on the TXP\_MR\_E, TXP\_MR\_10G, TXP\_MR\_2.5G, TXPP\_MR\_2.5G, MXP\_2.5G\_10G, OC192-XFP, ADM-10G, or OTU2\_XP card transmitted optical signal power. HI-TXPOWER occurs when the measured optical power of the transmitted signal exceeds the threshold.



**Note** For general information about MXP and TXP cards and power levels, refer to the “Card Reference” chapter in the *Cisco ONS 15454 DWDM Reference Manual*. For information about provisioning them, refer to the “Provision Transponder and Muxponder Cards” chapter in the *Cisco ONS 15454 DWDM Procedure Guide*.

## Clear the HI-TXPOWER Alarm

- 
- Step 1** Check the PM of the Trunk-Tx port. Verify that received power is above the optics threshold:
- In node view (single-shelf mode) or shelf view (multishelf mode), double-click the card to display the card view.
  - For the Trunk-Tx port, double-click the card and click the **Performance > Optics PM > Historical PM** tabs, choose the port in the **Port** drop-down list, and click **Refresh**.
  - Compare the refreshed PM values with the threshold (ensuring that it is above the threshold value) by clicking the **Performance > Optics PM > Current Values** tabs.
  - Ensure that a proper threshold has been provisioned for the receive value. (Refer to the “Provision Transponder and Muxponder Cards” chapter in the *Cisco ONS 15454 DWDM Procedure Guide*.) If an incorrect threshold has been set, adjust it to a value within the allowed limits. If instead the alarm condition does not clear, move to next step.

- Step 2** Physically verify, by using a standard power meter that the optical output power is overcoming the expected power threshold. If so, the card should be replaced at first opportunity



---

**Note** The higher power level is not a major issue for the DWDM card (32MUX-O, 40MUX, 32WSS-O, 40WSS-C, or AD-xC-xx.x) connected to the faulty TXP/MXP, because an internal VOA can automatically decrease the optical power to the expected level.

---

- Step 3** Complete the “[Physically Replace a Card](#)” procedure on page 2-244.
- Step 4** If the alarm does not clear after the replacement, log into the Technical Support Website at <http://www.cisco.com/techsupport> for more information or call Cisco TAC (1 800 553-2447) in order to report a Service-Affecting (SA) problem. If the alarm does not clear, log into the Technical Support Website at <http://www.cisco.com/techsupport> for more information or call Cisco TAC (1-800-553-2447).
- 

## 2.5.122 HLDVRSYNC

Default Severity: Not Alarmed (NA), Non-Service-Affecting (NSA)

Logical Object: NE-SREF

The Holdover Synchronization Mode condition is caused by loss of the primary and second timing references in the node. Timing reference loss occurs when line coding on the timing input is different from the configuration on the node, and it often occurs during the selection of a new node reference clock. The condition clears when primary or second timing is reestablished. After the 24-hour holdover period expires, timing slips could begin to occur on an ONS system relying on an internal clock.

## Clear the HLDVRSYNC Condition

- 
- Step 1** Clear additional alarms that relate to timing, such as:
- [2.5.101 FRNGSYNC](#), page 2-88
  - [2.5.102 FSTSYNC](#), page 2-89

- 2.5.152 LOF (BITS), page 2-126
- 2.5.162 LOS (BITS), page 2-134
- 2.5.187 MANSWTOINT, page 2-156
- 2.5.188 MANSWTOPRI, page 2-156
- 2.5.189 MANSWTOSEC, page 2-156
- 2.5.190 MANSWTOTHIRD, page 2-156
- 2.5.291 SWTOPRI, page 2-217
- 2.5.292 SWTOSEC, page 2-217
- 2.5.293 SWTOTHIRD, page 2-217
- 2.5.294 SYNC-FREQ, page 2-218
- 2.5.296 SYNCPRI, page 2-219
- 2.5.297 SYNCSEC, page 2-220
- 2.5.298 SYNCTHIRD, page 2-220

**Step 2** Reestablish a primary and secondary timing source according to local site practice. If none exists, refer to the “Turn Up the Network” chapter in the *Cisco ONS 15454 DWDM Procedure Guide*.

**Step 3** If the condition does not clear, log into the Technical Support Website at <http://www.cisco.com/techsupport> for more information or call Cisco TAC (1-800-553-2447) in order to report a Service-Affecting (SA) problem.

---

## 2.5.123 HP-DEG

Default Severity: Not Alarmed (NA), Non-Service-Affecting (NSA)

Logical Object: VMMON-HP, VCTRM-HP

An HP-DEG condition is similar to the “SD (TRUNK)” condition, page 2-201, but it applies to the HP layer of the SDH overhead. A HP-DEG alarm travels on the B3 byte of the SDH overhead.

For path protection protected circuits, the BER threshold is user-provisionable and has a range for HP-DEG from 1E-9 dBm to 1E-5 dBm. For MS-SPRing 1+1 and unprotected circuits, the BER threshold value is not user-provisionable and the error rate is hard-coded to 1E-6 dBm.

On path protection configurations, an HP-DEG condition causes a switch from the working card to the protect card at the path level. On MS-SPRing, 1+1, and on unprotected circuits, an HP-DEG condition does not cause switching.

The BER increase that causes the condition is sometimes caused by a physical fiber problem such as a poor fiber connection, a bend in the fiber that exceeds the permitted bend radius, or a bad fiber splice.

HP-DEG clears when the BER level falls to one-tenth of the threshold level that triggered the alarm.

### Clear the HP-DEG Condition

---

**Step 1** Complete the “Clear the SD (TRUNK) Condition” procedure on page 2-201.

- Step 2** If the condition does not clear, log into the Technical Support Website at <http://www.cisco.com/techsupport> for more information or call Cisco TAC (1-800-553-2447).
- 

## 2.5.124 HP-ENCAP-MISMATCH

Default Severity: Critical (CR), Service-Affecting (SA)

Logical Object: VCTRM-HP

The High-Order Path Encapsulation C2 Byte Mismatch alarm applies to ML-Series Ethernet cards. It occurs when the first three following conditions are met and one of the last two is false:

- The received C2 byte is not 0x00 (unequipped).
- The received C2 byte is not a PDI value.
- The received C2 does not match the expected C2.
- The expected C2 byte is not 0x01 (equipped unspecified).
- The received C2 byte is not 0x01 (equipped unspecified).

(This is in contrast to LP-PLM, which must meet all five criteria.) For an HP-ENCAP-MISMATCH to be raised, there is a mismatch between the received and expected C2 byte, with either the expected byte or received byte value being 0x01.

An example situation that would raise an HP-ENCAP-MISMATCH alarm is if a circuit created between two ML-Series cards has GFP framing provisioned on one end and high-level data link control (HDLC) framing with LEX encapsulation provisioned on the other. The GFP framing card transmits and expects a C2 byte of 0x1B, while the HDLC framing card transmits and expects a C2 byte of 0x01.

A mismatch between the transmit and receive cards on any of the following parameters can cause the alarm:

- Mode (HDLC, GFP-F)
- Encapsulation (LEX, HDLC, PPP)
- CRC size (16 or 32)
- Scrambling state (on or off)

This alarm is demoted by a path label mismatch (PLM) such as LP-PLM.



**Note**

By default, an HP-ENCAP-MISMATCH alarm causes an ML-Series card data link to go down. This behavior can be modified using the command-line interface (CLI) command **no pos trigger defect encap**.

---



**Note**

For more information about the ML-Series Ethernet card, refer to the *Ethernet Card Software Feature and Configuration Guide for the Cisco ONS 15454, Cisco ONS 15454 SDH, and Cisco ONS 15327*.

---



## Clear the HP-ENCAP-MISMATCH Alarm

- 
- Step 1** Ensure that the correct framing mode is in use on the receiving card by completing the following steps:
- In node view, double-click the ML-Series card to display the card view.
  - Click the **Provisioning > Card** tabs.
  - In the Mode drop-down list, ensure that the correct mode (GFP-F or HDLC) is selected. If it is not, choose it and click **Apply**.
- Step 2** Ensure that the correct framing mode is in use on the transmit card, and that it is identical to the framing mode used on the receiving card by completing the following steps:
- In node view, double-click the ML-Series card to display the card view.
  - Click the **Provisioning > Card** tabs.
  - In the Mode drop-down list, ensure that the same mode (GFP-F or HDLC) is selected. If it is not, choose it and click **Apply**.
- Step 3** If the alarm does not clear, use the ML-Series card CLI to ensure that the remaining settings are correctly configured:
- Encapsulation
  - CRC size
  - Scrambling state
- To open the interface, click the card view **IOS** tab and click **Open IOS Connection**. Refer to the *Ethernet Card Software Feature and Configuration Guide for the Cisco ONS 15454, Cisco ONS 15454 SDH, and Cisco ONS 15327* entries on all three of these topics to obtain the full configuration command sequences.
- Step 4** If the alarm does not clear, log into the Cisco Technical Support Website at <http://www.cisco.com/techsupport> for more information or log into <http://www.cisco.com/warp/public/687/Directory/DirTAC.shtml> to obtain a directory of toll-free Technical Support numbers for your country.

## 2.5.125 HP-EXC

Default Severity: Not Alarmed (NA), Non-Service-Affecting (NSA)

Logical Objects: VCMON-HP, VCTRM-HP

An HP-EXC condition is similar to the “[SF \(TRUNK\) condition, page 2-204](#)”, but it applies to the path layer B3 byte of the SONET overhead. It can trigger a protection switch.

The HP-EXC condition clears when the BER level falls to one-tenth of the threshold level that triggered the condition. A BER increase is sometimes caused by a physical fiber problem, including a poor fiber connection, a bend in the fiber that exceeds the permitted bend radius, or a bad fiber splice.

## Clear the HP-EXC Condition

- 
- Step 1** Complete the “[Clear the SF \(TRUNK\) Condition](#)” procedure on page 2-204.

- Step 2** If the condition does not clear, log into the Technical Support Website at <http://www.cisco.com/techsupport> for more information or call Cisco TAC (1-800-553-2447).
- 

## 2.5.126 HP-PLM

The HP-PLM condition is not used in this platform in this release. It is reserved for development.

## 2.5.127 HP-RFI

Default Severity: Not Reported (NR), Non-Service-Affecting (NSA)

Logical Object: VCMON-HP

The High-Order Remote Failure Indication (RFI) condition indicates that there is a remote failure indication in the high-order (VC-4 or VC-3) path, and that the failure has persisted beyond the maximum time allotted for transmission system protection. The HP-RFI is sent as the protection switch is initiated. Resolving the fault in the adjoining node clears the HP-RFI condition in the reporting node.

### Clear the HP-RFI Condition

---

- Step 1** Log into the node at the far end of the reporting ONS 15454.
- Step 2** Determine whether there are any related alarms, especially the LOS(STM1E, STMN).
- Step 3** Clear the main alarm. See the appropriate alarm section in this chapter for procedures.
- Step 4** If the condition does not clear, log into the Cisco Technical Support Website at <http://www.cisco.com/techsupport> for more information or log into <http://www.cisco.com/warp/public/687/Directory/DirTAC.shtml> to obtain a directory of toll-free Technical Support numbers for your country.
- 

## 2.5.128 HP-TIM

Default Severities: Critical (CR), Service-Affecting (SA) for VCTRM-HP; Minor (MN), Non-Service-Affecting (NSA) for VCMON-HP

Logical Objects: VCMON-HP, VCTRM-HP

The TIM High-Order TIM Failure alarm indicates that the trace identifier J1 byte of the high-order (VC-4 or VC-3) overhead is faulty. HP-TIM occurs when there is a mismatch between the transmitted and received J1 identifier byte in the SONET path overhead. The error can originate at the transmit end or the receive end.

## Clear the HP-TIM Alarm

- 
- Step 1** Use an optical test set capable of viewing SONET path overhead to determine the validity of the J1 byte. For specific procedures to use the test set equipment, consult the manufacturer. Examine the signal as near to the reporting card as possible.
- Examine the signal as close as possible to the output card.
- Step 2** If the output card signal is valid, complete the “Clear the SYNCPRI Alarm” procedure on page 2-219.
- Step 3** If the alarm does not clear, log into the Technical Support Website at <http://www.cisco.com/techsupport> for more information or log into <http://www.cisco.com/warp/public/687/Directory/DirTAC.shtml> to obtain a directory of toll-free Technical Support numbers for your country. If the alarm applies to VCTRM-HP, it is a service-affecting problem.
- 

## 2.5.129 HP-UNEQ

Default Severity: Critical (CR), Service-Affecting (SA)

Logical Object: VCMON-HP, VCTRM-HP

The signal label mismatch fault (SLMF) Unequipped High-Order Path alarm applies to the C2 path signal label byte in the high-order (VC-4) path overhead. HP-UNEQ occurs when no C2 byte is received in the SONET path overhead.

## Clear the HP-UNEQ Alarm

- 
- Step 1** From the View menu, choose **Go to Network View**.
- Step 2** Right-click the alarm to display the Select Affected Circuits shortcut menu.
- Step 3** Click **Select Affected Circuits**.
- Step 4** When the affected circuits appear, look in the Type column for a virtual circuit (VC).
- Step 5** If the Type column does not contain a VC, there are no VCs. Go to [Step 7](#).
- Step 6** If the Type column does contain a VC, attempt to delete these row(s) by completing the following steps:



**Note** The node does not allow you to delete a valid VC.

---

- Click the VC row to highlight it. Complete the “Delete a Circuit” procedure on page 2-245.
  - If an error message dialog box appears, the VC is valid and not the cause of the alarm.
  - If any other rows contain VT, repeat Steps [a](#) through [b](#).
- Step 7** If all ONS nodes in the ring appear in the CTC network view, verify that the circuits are all complete by completing the following steps:
- Click the **Circuits** tab.
  - Verify that INCOMPLETE is not listed in the Status column of any circuits.

- Step 8** If you find circuits listed as incomplete, verify that these circuits are not working circuits that continue to pass traffic, using an appropriate optical test set and site-specific procedures. For specific procedures to use the test set equipment, consult the manufacturer.
- Step 9** If the incomplete circuits are not needed or are not passing traffic, delete the incomplete circuits. Complete the [“Delete a Circuit” procedure on page 2-245](#).
- Step 10** Recreate the circuit with the correct circuit size. Refer to the “Create Circuits and Tunnels” chapter in the *Cisco ONS 15454 Procedure Guide* for circuit procedures.
- Step 11** Log back in and verify that all circuits terminating in the reporting card are active by completing the following steps:
- Click the **Circuits** tab.
  - Verify that the **Status** column lists all circuits as active.
- Step 12** If the alarm does not clear, clean the far-end optical fiber according to site practice. If no site practice exists, complete the procedure in the “Maintain the Node” chapter in the *Cisco ONS 15454 Procedure Guide*.

**Warning**

---

**On the OC192 LR/STM64 LH 1550 card, the laser is on when the card is booted and the safety key is in the on position (labeled 1). The port does not have to be in service for the laser to be on. The laser is off when the safety key is off (labeled 0).** Statement 293

---

**Warning**

---

**Invisible laser radiation could be emitted from the end of the unterminated fiber cable or connector. Do not stare into the beam directly with optical instruments. Viewing the laser output with certain optical instruments (for example, eye loupes, magnifiers, and microscopes) within a distance of 100 mm could pose an eye hazard.** Statement 1056

---

**Warning**

---

**Use of controls, adjustments, or performing procedures other than those specified could result in hazardous radiation exposure.** Statement 1057

---

- Step 13** If the alarm does not clear, complete the [“Physically Replace a Card” procedure on page 2-244](#) for the optical and/or electrical cards.

**Caution**

---

Removing a card that currently carries traffic on one or more ports can cause a traffic hit. To avoid this, perform an external switch if a switch has not already occurred. Refer to the “Maintain the Node” chapter in the *Cisco ONS 15454 Procedure Guide* for information.

---

**Note**

---

When you replace a card with the identical type of card, you do not need to make any changes to the database.

---

- Step 14** If the alarm does not clear, log into the Cisco Technical Support Website at <http://www.cisco.com/techsupport> for more information or log into <http://www.cisco.com/warp/public/687/Directory/DirTAC.shtml> to obtain a directory of toll-free Technical Support numbers for your country in order to report a Service-Affecting (SA) problem.
-

## 2.5.130 I-HITEMP

Default Severity: Critical (CR), Service-Affecting (SA)

Logical Object: NE

The Industrial High Temperature alarm occurs when the temperature of the ONS system is above 149 degrees F (65 degrees C) or below -40 degrees F (-40 degrees C). This alarm is similar to the HITEMP alarm but is used for the industrial environment. If this alarm is used, you can customize your alarm profile to ignore the lower-temperature HITEMP alarm.

### Clear the I-HITEMP Alarm

- 
- Step 1** Complete the “[Clear the HITEMP Alarm](#)” procedure on page 2-100.
- Step 2** If the alarm does not clear, log into the Technical Support Website at <http://www.cisco.com/techsupport> for more information or call TAC (1-800-553-2447) in order to report a Service-Affecting (SA) problem.
- 

## 2.5.131 ILK-FAIL

Default Severity: Major (MJ), Service-Affecting (SA)

Logical Object: TRUNK

The ADM Peer Group Interlink Failure condition is raised on the ADM-10G card. This condition occurs when one of the following SONET/OTN alarms is detected on the interlink ports of the ADM-10G card.

- “[LOS \(TRUNK\)](#)” alarm, page 2-136
- “[LOF \(TRUNK\)](#)” alarm, page 2-127
- “[SF \(TRUNK\)](#)” alarm, page 2-204

### Clear the ILK-FAIL Alarm

- 
- Step 1** Clear the root-cause service-affecting alarm by using one of the following procedures, as appropriate:
- “[Clear the LOS \(TRUNK\) Alarm](#)” procedure on page 2-137
  - “[Clear the LOF \(TRUNK\) Alarm](#)” procedure on page 2-127
  - “[Clear the SF \(TRUNK\) Condition](#)” procedure on page 2-204
- Step 2** If the alarm does not clear, log into the Technical Support Website at <http://www.cisco.com/techsupport> for more information or call TAC (1-800-553-2447) in order to report a Service-Affecting (SA) problem.
- 

## 2.5.132 IMPROPRMVL

Default Severity: Critical (CR), Service-Affecting (SA)

Logical Objects: EQPT, PPM

The Improper Removal (IMPROPRMVL) alarm occurs under the following conditions:

- A card is removed when the card was rebooting. It is recommended that after the card completely reboots, delete the card in CTC and only then remove the card physically. When you delete the card, CTC loses connection with the node view (single-shelf mode) or shelf view (multishelf mode), and goes to network view.
- When a card is physically removed from its slot before it is deleted from CTC. It is recommended that any card be deleted in CTC before physically removing the card from the chassis.



**Note** CTC provides the user approximately 15 seconds to physically remove the card before it begins rebooting the card.  
It can take up to 30 minutes for software to be updated on a standby TCC2/TCC2P card.

- A card is inserted into a slot but is not fully plugged into the backplane.
- A PPM (SFP) is provisioned but the physical module is not inserted into the port.
- Removal of an SFP from the client ports of a Y-cable protection group card causes an IMPROPRMVL (PPM) alarm.

The working port raises the CR,IMPROPRMVL,SA alarm and the protected port raises the MN,IMPROPRMVL,NSA alarm. The severity on the client ports is changed according to the protection switch state.

For more information about protection schemes, refer to the “Manage the Node” chapter of the *Cisco ONS 15454 DWDM Procedure Guide*.

For more information about provisioning PPMs (SFPs), refer to the “Turn Up a Node” chapter of the *Cisco ONS 15454 DWDM Procedure Guide*. For specific PPM (SFP) values, refer to the “Hardware Specifications” appendix of the *Cisco ONS 15454 DWDM Reference Manual*.

- Electrical issues such as short circuit or failure of DC-DC conversion.

## Clear the IMPROPRMVL Alarm

**Step 1** In node view (single-shelf mode) or shelf view (multishelf mode), right-click the card reporting the IMPROPRMVL.

**Step 2** Choose **Delete** from the shortcut menu.



**Note** CTC does not allow you to delete the reporting card if the card is in service, does have circuits mapped to it, is paired in a working protection scheme, has DCC enabled, or is used as a timing reference.

**Step 3** If any ports on the card are in service, place them out of service (OOS,MT or Locked,maintenance):



### Caution

Before placing a port out of service (OOS,MT or Locked,maintenance) or OOS,DSBLD (or Locked,disabled), ensure that no live traffic is present.

- In node view (single-shelf mode) or shelf view (multishelf mode), double-click the reporting card to open the card view.
- Click the **Provisioning > Line** tabs.

- c. Click the Admin State column of any in-service (IS or Unlocked) ports.
- d. Choose **OOS,MT** (or **Locked,maintenance**) to take the ports out of service.

**Step 4** If a circuit has been mapped to the card, complete the “[Delete a Circuit](#)” procedure on page 2-245.



**Caution** Before deleting the circuit, ensure that the circuit does not carry live traffic.

**Step 5** If the card is paired in a protection scheme, delete the protection group by completing the following steps:

- a. Click **View > Go to Previous View** to return to node view (single-shelf mode) or shelf view (multishelf mode).
- b. If you are already in node view (single-shelf mode) or shelf view (multishelf mode), click the **Provisioning > Protection** tab.
- c. Click the protection group of the reporting card.
- d. Click **Delete**.

**Step 6** If the card is provisioned for DCC, delete the DCC provisioning by completing the following steps:

- a. In node view (single-shelf mode) or multishelf view (multishelf mode), click the ONS system **Provisioning > Comm Channels > SDCC** (or **Provisioning > Comm Channels > MS DCC**) tabs.
- b. Click the slots and ports listed in DCC terminations.
- c. Click **Delete** and click **Yes** in the dialog box that appears.

**Step 7** If the card is used as a timing reference, change the timing reference by completing the following steps:

- a. In node view (single-shelf mode) or shelf view (multishelf mode), click the **Provisioning > Timing > General** tabs.
- b. Under NE Reference, click the drop-down arrow for **Ref-1**.
- c. Change Ref-1 from the listed OC-N/STM-N card to **Internal Clock**.
- d. Click **Apply**.

**Step 8** If the alarm does not clear, log into the Technical Support Website at <http://www.cisco.com/techsupport> for more information or call Cisco TAC (1-800-553-2447) in order to report a Service-Affecting (SA) problem.

## 2.5.133 INHSWPR

Default Severity: Not Alarmed (NA), Non-Service-Affecting (NSA)

Logical Object: EQPT

The Inhibit Switch To Protect Request on Equipment condition occurs on traffic cards when the ability to switch to protect has been disabled. If the card is part of a 1:1 or 1+1 protection scheme, traffic remains locked onto the working system. If the card is part of a 1:N protection scheme, traffic can be switched between working cards when the switch to protect is disabled.

## Clear the INHSWPR Condition

- 
- Step 1** If the condition is raised against a 1+1 port, complete the [“Initiate a 1+1 Manual Switch Command” procedure on page 2-237](#).
  - Step 2** If it is raised against a 1:1 card, complete the [“Initiate a 1:1 Card Switch Command” procedure on page 2-238](#) to switch it back.
  - Step 3** If the condition does not clear, log into the Cisco Technical Support Website at <http://www.cisco.com/techsupport> for more information or log into <http://www.cisco.com/warp/public/687/Directory/DirTAC.shtml> to obtain a directory of toll-free Technical Support numbers for your country.
- 

## 2.5.134 INHSWWKG

Default Severity: Not Alarmed (NA), Non-Service-Affecting (NSA)

Logical Object: EQPT

The Inhibit Switch To Working Request on Equipment condition occurs on traffic cards when the ability to switch to working has been disabled. If the card is part of a 1:1 or 1+1 protection scheme, traffic remains locked onto the protect system. If the card is part of a 1:N protection scheme, traffic can be switched between protect cards when the switch to working is disabled.



**Note**

For more information about Ethernet cards, refer to the *Ethernet Card Software Feature and Configuration Guide for the Cisco ONS 15454, Cisco ONS 15454 SDH, and Cisco ONS 15327*.

---

## Clear the INHSWWKG Condition

- 
- Step 1** If the condition is raised against a 1+1 port, complete the [“Initiate a 1+1 Manual Switch Command” procedure on page 2-237](#).
  - Step 2** If it is raised against a 1:1 card, complete the [“Initiate a 1:1 Card Switch Command” procedure on page 2-238](#) to switch it back.
  - Step 3** If the condition does not clear, log into the Cisco Technical Support Website at <http://www.cisco.com/techsupport> for more information or log into <http://www.cisco.com/warp/public/687/Directory/DirTAC.shtml> to obtain a directory of toll-free Technical Support numbers for your country.
- 

## 2.5.135 INCOMPATIBLE-SEND-PDIP

Default Severity: Minor (MN), Non-Service-Affecting (NSA)

Logical Object: SYSTEM

The Incompatible Software alarm is raised when CTC'S send PDI-P provisioning differs from the host node's provisioning.



## Clear the INCOMPATIBLE-SEND-PDIP Alarm

- 
- Step 1** Reconfigure CTC's send PDI-P alarm capability to align with the host node settings.
  - Step 2** If the alarm does not clear, log into the Technical Support Website at <http://www.cisco.com/techsupport> for more information or call TAC (1-800-553-2447).
- 

## 2.5.136 INCOMPATIBLE-SW

Default Severity: Minor (MN), Non-Service-Affecting (NSA)

Logical Object: SYSTEM

The Incompatible Software alarm is raised when CTC cannot connect to the NE due to differing, incompatible versions of software between CTC and the NE. The alarm is cleared by restarting CTC in order to redownload the CTC JAR files from the NE.

## Clear the INCOMPATIBLE-SW Alarm

- 
- Step 1** Restart the CTC application.
  - Step 2** If the alarm does not clear, log into the Technical Support Website at <http://www.cisco.com/techsupport> for more information or call TAC (1-800-553-2447).
- 

## 2.5.137 INTRUSION-PSWD

Default Severity: Not Alarmed (NA), Non-Service-Affecting (NSA)

Logical Object: NE

The Security Intrusion Incorrect Password condition occurs after a user attempts a provisionable (by Superuser) number of unsuccessful logins, a login with an expired password, or an invalid password. The alarmed user is locked out of the system, and INTRUSION-PSWD condition is raised. This condition is only shown in Superuser login sessions, not in login sessions for lower-level users. The INTRUSION-PSWD condition is automatically cleared when a provisionable lockout timeout expires, or it can be manually cleared in CTC by the Superuser if the lockout is permanent.

## Clear the INTRUSION-PSWD Condition

- 
- Step 1** Log in as a user ID with superuser rights. (For more information about this, refer to the “Connect the PC and Log Into the GUI” chapter in the *Cisco ONS 15454 DWDM Procedure Guide*.)
  - Step 2** In node view (single-shelf mode) or multishelf view (multishelf mode), click the **Provisioning > Security > Users** tabs.
  - Step 3** Click **Clear Security Intrusion Alarm**.

- Step 4** If the condition does not clear, log into the Technical Support Website at <http://www.cisco.com/techsupport> for more information or call Cisco TAC (1-800-553-2447).

## 2.5.138 INVMACADR

Default Severity: Major (MJ), Non-Service Affecting (NSA)

Logical Object: AIP

The Equipment Failure Invalid MAC Address alarm occurs when the ONS system MAC address is invalid. Each ONS system has a unique, permanently assigned MAC address. The address resides on an AIP EEPROM. The TCC2/TCC2P card reads the address value from the AIP chip during boot-up and keeps this value in its synchronous dynamic RAM (SDRAM).

Under normal circumstances, the read-only MAC address can be viewed in the node view (single-shelf mode) or multishelf view (multishelf mode) Provisioning > Network tab in CTC.

The ONS system uses both IP and MAC addresses for circuit routing. When an INVMACADR alarm exists on a node, you see a PARTIAL circuit in the CTC circuit status column. The circuit works and is able to carry traffic, but CTC cannot logically display the circuit end-to-end information.

An invalid MAC address can be caused when:

- There is a read error from the AIP during boot-up; in this case, the reading TCC2/TCC2P card uses the default MAC address (00-10-cf-ff-ff-ff).
- There is a read error occurring on one of the redundant TCC2/TCC2P cards that read the address from the AIP; these cards read the address independently and could therefore each read different address values.
- An AIP component failure causes a read error.
- The ribbon cable connecting the AIP card to the backplane is bad.

### Clear the INVMACADR Alarm

- Step 1** Check for any outstanding alarms that were raised against the active and standby TCC2/TCC2P card and resolve them.
- Step 2** If the alarm does not clear, determine whether the LCD display on the fan tray ([Figure 2-2 on page 2-101](#)) is blank or if the text is garbled. If so, proceed to [Step 8](#). If not, continue with [Step 3](#).
- Step 3** At the earliest maintenance window, reset the standby TCC2/TCC2P card:



**Note** The reset requires approximately five minutes. Do not perform any other step until the reset is complete.

- a. Log into a node on the network. If you are already logged in, continue with [Step b](#).
- b. Identify the active TCC2/TCC2P card.  
A green ACT/SBY LED indicates an active card. An amber ACT/SBY LED indicates a standby card.
- c. In node view (single-shelf mode) or shelf view (multishelf mode), right-click the standby TCC2/TCC2P card in CTC.

- d. Choose **Reset Card** from the shortcut menu.
- e. Click **Yes** in the Are You Sure dialog box.  
The card resets, the FAIL LED blinks on the physical card, and connection to the node is lost. CTC switches to network view.
- f. Verify that the reset is complete and error-free, and that no new related alarms appear in CTC. A green ACT/SBY LED indicates an active card. An amber ACT/SBY LED indicates a standby card.
- g. Double-click the node and ensure that the reset TCC2/TCC2P card is still in standby mode and that the other TCC2/TCC2P card is active.  
A green ACT/SBY LED indicates an active card. An amber ACT/SBY LED indicates a standby card.
- h. Ensure that no new alarms associated with this reset appear in the CTC Alarms window.

If the standby TCC2/TCC2P card fails to boot into standby mode and reloads continuously, the AIP is probably defective. In this case, the standby TCC2/TCC2P card is unsuccessfully attempting to read the EEPROM located on the AIP. The TCC2/TCC2P card reloads until it reads the EEPROM. Proceed to [Step 8](#).

- Step 4** If the standby TCC2/TCC2P card rebooted successfully into standby mode, complete the [“Remove and Reinsert \(Reseat\) the Standby TCC2/TCC2P Card” procedure on page 2-242](#).

Resetting the active TCC2/TCC2P card causes the standby TCC2/TCC2P card to become active. The standby TCC2/TCC2P card keeps a copy of the chassis MAC address. If its stored MAC address is valid, the alarm should clear.

- Step 5** After the reset, note whether or not the INVMACADR alarm has cleared or is still present.

- Step 6** Complete the [“Reset an Active TCC2/TCC2P Card and Activate the Standby Card” procedure on page 2-241](#) again to place the standby TCC2/TCC2P card back into active mode.

After the reset, note whether or not the INVMACADR alarm has cleared or is still present. If the INVMACADR alarm remains standing through both TCC2/TCC2P card resets, this indicates that the AIP is probably defective. Proceed to [Step 8](#).

If the INVMACADR was raised during one TCC2/TCC2P card reset and cleared during the other, the TCC2/TCC2P card that was active while the alarm was raised needs to be replaced. Continue with [Step 7](#).

- Step 7** If the faulty TCC2/TCC2P card is currently in standby mode, complete the [“Physically Replace a Card” procedure on page 2-244](#) for this card. If the faulty TCC2/TCC2P card is currently active, during the next available maintenance window complete the [“Reset an Active TCC2/TCC2P Card and Activate the Standby Card” procedure on page 2-241](#) and then complete the [“Physically Replace a Card” procedure on page 2-244](#).



---

**Note** If the replacement TCC2/TCC2P card is loaded with a different software version from the current TCC2/TCC2P card, the card boot-up could take up to 30 minutes. During this time, the card LEDs flicker between Fail and Act/Sby as the active TCC2/TCC2P card version software is copied to the new standby card.

---

- Step 8** Open a case with Cisco TAC (1 800 553-2447) for assistance with determining the node’s previous MAC address.

- Step 9** Replace the ribbon cable between the system board and the AIP with a known-good cable.

- Step 10** If the alarm persists, complete the [“Replace an Alarm Interface Panel” procedure](#) located in the [“Alarm Troubleshooting” chapter](#) of the *Cisco ONS 15454 Troubleshooting Guide*.

- Step 11** If the alarm does not clear, log into the Technical Support Website at <http://www.cisco.com/techsupport> for more information or call Cisco TAC (1-800-553-2447).
- 

## 2.5.139 ISIS-ADJ-FAIL

Default Severity: Minor (MN), Non-Service-Affecting (NSA)

Logical Object: OCN

The Open System Interconnection (OSI) Intermediate System to Intermediate-System (IS-IS) Adjacency Failure alarm is raised by an intermediate system (node routing IS Level 1 or Level 1 and 2) when no IS or end system (ES) adjacency is established on a point-to-point subnet. The Intermediate-System Adjacency Failure alarm is not supported by ES. It is also not raised by IS for disabled routers.

The alarm is typically caused by a misconfigured router manual area adjacency (MAA) address. For more information about IS-IS OSI routing and MAA configuration, refer to the “Management Network Connectivity” chapter in the *Cisco ONS 15454 SDH Reference Manual*. For more information about configuring OSI, refer to the “Turn Up Node” chapter in the *Cisco ONS 15454 Procedure Guide* for procedures.

### Clear the ISIS-ADJ-FAIL Alarm

- 
- Step 1** Ensure that both ends of the communication channel are using the correct Layer 2 protocol and settings (LAPD or PPP). To do this, complete the following steps:
- At the local node, in node view, click the **Provisioning > Comm Channels > MSDCC** tabs.
  - Click the row of the circuit. Click **Edit**.
  - In the Edit MSDCC termination dialog box, view and record the following selections: Layer 2 protocol (LAPD or PPP); Mode radio button selection (AITS or UITS); Role radio button selection (Network or User); MTU value; T200 value, and T203 selections.
  - Click **Cancel**.
  - Log in to the remote node and follow the same steps, also recording the same information for this node.
- Step 2** If both nodes do not use the same Layer 2 settings, you will have to delete the incorrect termination and recreate it. To delete it, click the termination and click **Delete**. To recreate it, refer to the “Turn Up Node” chapter in the *Cisco ONS 15454 Procedure Guide* for the procedure.
- Step 3** If the nodes use PPP Layer 2, complete the [“Clear the RS-EOC Alarm” procedure on page 2-199](#). If the alarm does not clear, go to [Step 7](#).
- Step 4** If both nodes use the LAPD Layer 2 protocol but have different Mode settings, change the incorrect node’s entry by clicking the correct setting radio button in the Edit MSDCC termination dialog box and clicking **OK**.
- Step 5** If the Layer 2 protocol and Mode settings are correct, ensure that one node is using the Network role and the other has the User role. If not (that is, if both have the same mode settings), correct the incorrect one by clicking the correct radio button in the Edit MSDCC termination dialog box and clicking **OK**.
- Step 6** If the Layer 2, Mode, and Role settings are correct, compare the MTU settings for each node. If one is incorrect, choose the correct value in the Edit MSDCC dialog box and click **OK**.

- Step 7** If all of the preceding settings are correct, ensure that OSI routers are enabled for the communications channels at both ends by completing the following steps:
- Click **Provisioning > OSI > Routers > Setup**.
  - View the router entry under the **Status** column. If the status is Enabled, check the other end.
  - If the Status is Disabled, click the router entry and click **Edit**.
  - Check the **Enabled** check box and click **OK**.
- Step 8** If the routers on both ends are enabled and the alarm still has not cleared, ensure that both ends of the communications channel have a common MAA by completing the following steps:
- Click the **Provisioning > OSI > Routers > Setup** tabs.
  - Record the primary MAA and secondary MAAs, if configured.

**Tip**

You can record long strings of information such as the MAA address by using the CTC export and print functions. Export it by choosing File > Export > html. Print it by choosing File > Print.

- Log into the other node and record the primary MAA and secondary MAAs, if configured.
- Compare this information. There should be at least one common primary or secondary MAA in order to establish an adjacency.
- If there is no common MAA, one must be added to establish an adjacency. Refer to the “Turn Up Node” chapter of the *Cisco ONS 15454 Procedure Guide* for procedures to do this.

- Step 9** If the condition does not clear, log into the Cisco Technical Support Website at <http://www.cisco.com/techsupport> for more information or log into <http://www.cisco.com/warp/public/687/Directory/DirTAC.shtml> to obtain a directory of toll-free Technical Support numbers for your country.

## 2.5.140 LASER-APR

Default Severity: Not Alarmed (NA), Non-Service-Affecting (NSA)

Logical Object: AOTS

The Laser Automatic Power Reduction (APR) alarm condition is raised by OSC-CSM, OSCM, OPT-BST, OPT-PRE, OPT-AMP-C, and OPT-AMP-17-C cards when the laser is working in power reduction mode. The condition clears as soon as safety conditions are released and the power value reaches the normal setpoint.

**Warning**

**Invisible laser radiation may be emitted from disconnected fibers or connectors. Do not stare into beams or view directly with optical instruments. Statement 1051.**

**Note**

Only inactivate the APR function temporarily for installation or maintenance reasons. Activate APR immediately after maintenance or installation.

**Note**

LASER-APR is an informational condition and does not require troubleshooting. For more information about optical amplifier APR, refer to the “Card Reference” chapter in the *Cisco ONS 15454 DWDM Reference Manual*.

## 2.5.141 LASERBIAS-DEG

Default Severity: Minor (MN), Non-Service-Affecting (NSA)

Logical Objects: AOTS, OTS

The Laser Bias Current Degrade alarm occurs on an amplifier card (OPT-BST, OPT-PRE, OPT-AMP-C, or OPT-AMP-17-C) when laser aging causes a degrade, but not failure, of laser transmission. The card should be replaced at the next opportunity.

**Note**

For general information about optical amplifier cards, refer to the “Card Reference” chapter in the *Cisco ONS 15454 DWDM Reference Manual*. For information about changing their settings, refer to the “Change DWDM Card Settings” chapter in the *Cisco ONS 15454 DWDM Procedure Guide*.

### Clear the LASERBIAS-DEG Alarm

- Step 1** For the alarmed card, complete the [“Physically Replace a Card” procedure on page 2-244](#) at the next opportunity.

**Warning**

**Invisible laser radiation may be emitted from the end of the unterminated fiber cable or connector. Do not view directly with optical instruments. Viewing the laser output with certain optical instruments (for example, eye loupes, magnifiers, and microscopes) within a distance of 100 mm may pose an eye hazard. Statement 1056**

**Note**

Before disconnecting any optical amplifier card fiber for troubleshooting, ensure that the optical amplifier card is unplugged.

- Step 2** If the alarm does not clear, log into the Technical Support Website at <http://www.cisco.com/techsupport> for more information or call Cisco TAC (1-800-553-2447).

## 2.5.142 LASERBIAS-FAIL

Default Severity: Major (MJ), Non-Service-Affecting (NSA)

Logical Object: AOTS

The Laser Bias Current Failure alarm occurs on an amplifier card (OPT-BST, OPT-PRE, OPT-AMP-C, and OPT-AMP-17-C) when the laser control circuit fails or if the laser itself fails service. The card must be replaced to restore traffic.

**Note**

For general information about optical amplifier cards, refer to the “Card Reference” chapter in the *Cisco ONS 15454 DWDM Reference Manual*. For information about changing their settings, refer to the “Change DWDM Card Settings” chapter in the *Cisco ONS 15454 DWDM Procedure Guide*.

## Clear the LASERBIAS-FAIL Alarm

**Step 1**

For the alarmed card, complete the “[Physically Replace a Card](#)” procedure on page 2-244.

**Warning**

**Invisible laser radiation may be emitted from the end of the unterminated fiber cable or connector. Do not view directly with optical instruments. Viewing the laser output with certain optical instruments (for example, eye loupes, magnifiers, and microscopes) within a distance of 100 mm may pose an eye hazard. Statement 1056**

**Note**

Before disconnecting any optical amplifier card fiber for troubleshooting, ensure that the optical amplifier card is unplugged.

**Step 2**

If the alarm does not clear, log into the Technical Support Website at <http://www.cisco.com/techsupport> for more information or call Cisco TAC (1-800-553-2447).

## 2.5.143 LASEREOL

Default Severity: Minor (MN), Non-Service-Affecting (NSA)

Logical Object: OCN

The Laser Approaching End of Life alarm applies to TXP\_MR\_10G, TXP\_MR\_2.5G, TXPP\_MR\_2.5G, TXP\_MR\_10E, and MXP\_2.5G\_10G cards. It is typically accompanied by the “[HI-LASERBIAS](#)” alarm on page 2-98. It is an indicator that the laser in the card must be replaced. How soon the replacement must happen depends upon the HI-LASERBIAS alarm’s threshold. If the threshold is set under 100 percent, the laser replacement can usually be done during a maintenance window. But if the HI-LASERBIAS threshold is set at 100 percent and is accompanied by data errors, LASEREOL indicates the card must be replaced sooner.

**Note**

For more information about MXP or TXP cards, refer to the *Cisco ONS 15454 DWDM Reference Manual*.

## Clear the LASEREOL Alarm

**Step 1**

Complete the “[Physically Replace a Card](#)” procedure on page 2-244.

**Step 2**

If the alarm does not clear, log into the Technical Support Website at <http://www.cisco.com/techsupport> for more information or call Cisco TAC (1-800-553-2447).

## 2.5.144 LASERTEMP-DEG

Default Severity: Minor (MN), Non-Service-Affecting (NSA)

Logical Object: AOTS

The Laser Temperature Degrade alarm occurs when the Peltier control circuit fails on an amplifier card (OPT-BST, OPT-PRE, OPT-AMP-C, and OPT-AMP-17-C). The Peltier control provides cooling for the amplifier. The card should be replaced at the next opportunity.



### Note

For general information about DWDM cards, refer to the “Card Reference” chapter in the *Cisco ONS 15454 DWDM Reference Manual*. For information about changing their settings, refer to the “Change DWDM Card Settings” chapter in the *Cisco ONS 15454 DWDM Procedure Guide*.

### Clear the LASERTEMP-DEG Alarm

- Step 1** For the alarmed DWDM card, complete the “[Physically Replace a Card](#)” procedure on page 2-244 at the next opportunity.



### Warning

**Invisible laser radiation may be emitted from the end of the unterminated fiber cable or connector. Do not view directly with optical instruments. Viewing the laser output with certain optical instruments (for example, eye loupes, magnifiers, and microscopes) within a distance of 100 mm may pose an eye hazard. Statement 1056**



### Note

Before disconnecting any optical amplifier card fiber for troubleshooting, ensure that the optical amplifier card is unplugged.

- Step 2** If the alarm does not clear, log into the Technical Support Website at <http://www.cisco.com/techsupport> for more information or call Cisco TAC (1-800-553-2447).

## 2.5.145 LMP-FAIL

Default Severity: Minor (MN), Non-Service-Affecting (NSA)

Logical Object: GE

The Link Management Protocol Fail alarm is raised by the TCC2/TCC2P card when an LMP control channel fails or when there is a traffic engineering (TE) link correlation error. When the alarm is raised against a control channel, it uses a control channel (CTRLx) AID. When the alarm is raised against a TE link, a TE link AID (TLINKx) is used.

The alarm clears when the control channel or TE link is restored.



### Note

LMP-FAIL occurs independently of the condition hierarchy between [LMP-SD](#), page 122, [LMP-SF](#), page 122, or [LMP-UNALLOC](#), page 124.



**Note**

When the LMP-FAIL alarm is reported against a control channel (CTRLx) AID, it only refers to control channel failure. It does not directly indicate data link or traffic engineering link status.

**Note**

When the LMP-FAIL alarm is reported against a TE link AID (TLINKx), it refers only to TE link status, not to control channel or data link status.

## Clear the LMP-FAIL Alarm

- 
- Step 1** Verify the AID (CTRLx or TLINKx) of the alarm.
- Step 2** If the alarm is against the control channel AID, this is caused by mismatched control channel parameters between the near-end ONS 15454 and the far-end node (which may be another vendor's equipment). Complete the following steps:
- Determine whether both near-end and far-end sides of the control channel are in the IS or Unlocked administrative state:
    - Click the **Provisioning > Comm Channels > LMP > Control Channels** tabs and view the Admin State column content for the channel.
    - If the status does not say IS or Unlocked, change it and click **Apply**.
  - Determine whether the near-end node LMP configuration contains the far-end node's IP address as its remote node IP. Also verify that the near-end node's LMP configuration uses the LMP node ID as its own remote node ID. If one or more of these values is incorrect, enter it correctly.
  - Determine whether the far-end node LMP configuration contains the near-end node's IP address as its remote node IP. Also verify that the far-end node's LMP configuration uses the LMP node ID as its own remote node ID. If one or more of these values is incorrect, enter it correctly.
  - Verify that the far-end node is using the near-end node's IP address as its remote node IP address, and that the far end is also using the LMP node ID as its remote node ID. Update the far end's values if they are incorrect.
- Step 3** If instead the alarm is raised against the TE link AID, complete the following steps:
- Determine whether both near-end and far-end sides of the TE link are in the IS or Unlocked administrative state. If either end is currently down, update its administrative state to IS or Unlocked:
    - Click the **Provisioning > Comm Channels > LMP > TE links** tab.
    - If the status does not say IS or Unlocked, change it and click **Apply**.
  - Determine whether the near-end node's remote TE link ID matches the far-end node's local TE link ID. If the near-end node's remote value is incorrect, enter it correctly.
  - Determine whether the far-end node's remote TE link ID corresponds to the near-end node's local TE link ID. If the far-end node's remote value is incorrect, enter it correctly.
- Step 4** If the alarm does not clear, log into the Technical Support Website at <http://www.cisco.com/techsupport> for more information or call Cisco TAC (1-800-553-2447).
-

## 2.5.146 LMP-SD

Default Severity:Not Alarmed (NA), Non-Service-Affecting (NSA)

Logical Object: GE

The LMP Data Link Signal Degrade condition occurs for when the TCC2/TCC2P receives an LMP link summary or channel status message that the control channel is not available from the far end, so the data link level of service is not guaranteed. The degrade range is provisionable.

LMP-SD clears when the TCC2/TCC2P receives a link summary or channel status message reporting that the data link is in the Signal Okay (OK) state.

LMP-SD is part of an alarm hierarchy that includes [LMP-SF, page 122](#), and [LMP-UNALLOC, page 124](#). The hierarchy is as follows: If LMP-UNALLOC is raised, LMP-SF and LMP-SD are suppressed. If LMP-SF is raised, it suppresses LMP-SD. LMP-SF and LMP-UNALLOC both suppress near-end LOS-type alarms for DWDM clients. LMP-SD, however, does not suppress LOS alarms.

This condition clears when the far-end trouble has been cleared.

### Clear the LMP-SD Condition

- Step 1** Look for and clear any of the following alarms in [Table 2-9](#) and [Table 2-10](#) occurring on the far-end port.

**Table 2-9 Transponder Trunk Alarms that Cause LMP-SD**

| Trunk Port Alarm | LMP Failure | Direction |
|------------------|-------------|-----------|
| SD               | SD          | Tx        |
| OTUK-SD          | SD          | Tx        |
| ODUK-SD-PM       | SD          | Tx        |
| ODUK-SD-TCM1     | SD          | Tx        |
| ODUK-SD-TCM2     | SD          | Tx        |

**Table 2-10 Transponder Client Alarm that Causes LMP-SD**

| Client Port Alarm | LMP Failure | Direction |
|-------------------|-------------|-----------|
| SD                | SD          | Rx        |

- Step 2** If the LMP-SD condition does not clear, log into the Technical Support Website at <http://www.cisco.com/techsupport> for more information or call Cisco TAC (1-800-553-2447).

## 2.5.147 LMP-SF

Default Severity:Not Alarmed (NA), Non-Service-Affecting (NSA)

Logical Object: GE

The LMP Data Link Signal Fail condition notifies the near-end user of a far-end problem (and thus is NSA for the near end). The near-end's TCC2/TCC2P receives an LMP link summary or channel status message that the data link service has failed. The signal fail threshold is provisionable.

LMP-SF clears when the TCC2/TCC2P receives a link summary or channel status message reporting that the data link is in the Signal Okay (OK) state.

LMP-SF is part of an alarm hierarchy that includes [LMP-SD, page 122](#), and [LMP-UNALLOC, page 124](#). The hierarchy is as follows: If LMP-UNALLOC is raised, LMP-SF and LMP-SD are suppressed. If LMP-SF is raised, it suppresses LMP-SD. LMP-SF and LMP-UNALLOC both suppress near-end LOS-type alarms for DWDM clients, but LMP-SD does not suppress LOS-type alarms.

This condition clears when the far-end trouble has been cleared.

## Clear the LMP-SF Condition

- Step 1** Look for and clear any of the following alarms in [Table 2-11](#), [Table 2-12](#), or [Table 2-13](#) occurring on the far-end port.

**Table 2-11 Transponder Card Alarms that Cause LMP-SF**

| Card Alarm | LMP Failure | Direction |
|------------|-------------|-----------|
| EQPT       | SF          | Tx        |
| IMPROPRMVL | SF          | Tx        |

**Table 2-12 Transponder Trunk Alarms that Cause LMP-SF**

| Trunk Port Alarm | LMP Failure | Direction |
|------------------|-------------|-----------|
| LOS              | SF          | Tx        |
| OTUK-LOF         | SF          | Tx        |
| OTUK-AIS         | SF          | Tx        |
| LOM              | SF          | Tx        |
| OTUK-SF          | SF          | Tx        |
| ODUK-SF-PM       | SF          | Tx        |
| ODUK-SF-TCM1     | SF          | Tx        |
| ODUK-SF-TCM2 SF  | SF          | Tx        |
| FEC-MISM         | SF          | Tx        |

**Table 2-13 Transponder Client Alarms that Cause LMP-SF**

| Client Alarm | LMP Failure | Direction |
|--------------|-------------|-----------|
| LOS          | SF          | Rx        |
| SIGLOSS      | SF          | Rx        |
| SYNCLOSS     | SF          | Rx        |

**Table 2-13** Transponder Client Alarms that Cause LMP-SF (continued)

| Client Alarm | LMP Failure | Direction |
|--------------|-------------|-----------|
| CARLOSS      | SF          | Rx        |
| LOF          | SF          | Rx        |

**Step 2** If the condition does not clear, log into the Technical Support Website at <http://www.cisco.com/techsupport> for more information or call Cisco TAC (1-800-553-2447).

## 2.5.148 LMP-UNALLOC

Default Severity: Not Alarmed (NA), Non-Service-Affecting (NSA)

Logical Object: GE

The LMP Data Link Unallocated condition is raised when the TCC2/TCC2P receives an LMP link summary or channel status message reporting that the data link is unallocated for data traffic. The condition clears when the data link is allocated and sends an LMP link summary or channel status message to this effect. If a data link has the LMP-UNALLOC alarm raised against it, this should suppress all other alarms on the client port, since the far-end node is not using the errored port. (Consequently you do not have to clear any alarms on the far-end node's unused port.)

LMP-UNALLOC is part of an alarm hierarchy that includes [LMP-SD, page 122](#), and [LMP-SF, page 122](#). The hierarchy is as follows: If LMP-UNALLOC is raised, LMP-SF and LMP-SD are suppressed. If LMP-SF is raised, it suppresses LMP-SD. LMP-SF and LMP-UNALLOC both suppress near-end LOS-type DWDM client alarms, but LMP-SD does not.

In most cases, this condition is an informational notice at the near-end node that the far-end port is not being utilized. If, however, the far-end port should be allocated for traffic, log into the Technical Support Website at <http://www.cisco.com/techsupport> for more information or call Cisco TAC (1-800-553-2447).

## 2.5.149 LOCKOUT-REQ

Default Severity: Not Alarmed (NA), Non-Service-Affecting (NSA)

Logical Objects: 2R, EQPT, ESCON, FC, GE, ISC, OTS, TRUNK

The Lockout Switch Request on Facility or Equipment condition occurs when a user initiates a lockout switch request for an OC-N port in a 1+1 facility protection group. This can be accomplished by locking traffic onto the working port with the LOCK ON command (thus locking it off the protect port), or locking it off the protect port with the LOCK OUT command. In either case, the protect port will show "Lockout of Protection," and the Conditions window will show the LOCKOUT-REQ condition.

A lockout prevents protection switching. Clearing the lockout again allows protection switching and clears the LOCKOUT-REQ condition.

## Clear the LOCKOUT-REQ Condition

- 
- Step 1** Complete the “[Clear a Lock-On or Lockout Command](#)” procedure on page 2-240.
- Step 2** If the condition does not clear, log into the Cisco Technical Support Website at <http://www.cisco.com/techsupport> for more information or log into <http://www.cisco.com/warp/public/687/Directory/DirTAC.shtml> to obtain a directory of toll-free Technical Support numbers for your country.
- 

### 2.5.150 LOCKOUT-REQ (2R, EQPT, ESCON, FC, GE, ISC)

Default Severity: Not Alarmed (NA), Non-Service-Affecting (NSA)

Logical Objects: 2R, EQPT, ESCON, FC, GE, ISC

The Lockout Switch Request on Facility or Equipment condition occurs in a Y-cable MXP or TXP client protection group for the above-listed clients when a user initiates a lockout switch request. The condition is raised when you lock traffic onto the working port with the Lock On command (thus locking it off the protect port), or you lock it off the protect port with the Lock Out command. In either case, the protect port will show “Lockout of Protection,” and the Conditions window will show the LOCKOUT-REQ condition.

A lockout prevents protection switching. Clearing the lockout again allows protection switching and clears the LOCKOUT-REQ condition.

### Clear the LOCKOUT-REQ (2R, EQPT, ESCON, FC, GE, ISC) Condition

- 
- Step 1** Complete the “[Clear a Lock-On or Lockout Command](#)” procedure on page 2-240.
- Step 2** If the condition does not clear, log into the Technical Support Website at <http://www.cisco.com/techsupport> for more information or call Cisco TAC (1-800-553-2447).
- 

### 2.5.151 LOCKOUT-REQ (TRUNK)

Default Severity: Not Alarmed (NA), Non-Service-Affecting (NSA)

Logical Object: TRUNK

The Lockout Switch Request on Facility or Equipment condition occurs in an MXP or TXP trunk port splitter protection group when you lock traffic onto the working port with the Lock On command (thus locking it off the protect port), or lock it off the protect port with the Lock Out command. In either case, the protect port will show “Lockout of Protection,” and the Conditions window will show the LOCKOUT-REQ condition.

A lockout prevents protection switching. Clearing the lockout again allows protection switching and clears the LOCKOUT-REQ condition.

## Clear the LOCKOUT-REQ (TRUNK) Condition

- 
- Step 1** Complete the [“Clear a Lock-On or Lockout Command” procedure on page 2-240](#).
- Step 2** If the condition does not clear, log into the Technical Support Website at <http://www.cisco.com/techsupport> for more information or call Cisco TAC (1-800-553-2447).
- 

## 2.5.152 LOF (BITS)

Default Severity: Minor (MN), Non-Service-Affecting (NSA)

Logical Object: BITS

The Loss of Frame (LOF) BITS alarm occurs when a port on the TCC2/TCC2P card BITS input detects an LOF on the incoming BITS timing reference signal. LOF indicates that the receiving ONS system has lost frame delineation in the incoming data.



**Note**

The procedure assumes that the BITS timing reference signal is functioning properly. It also assumes the alarm is not appearing during node turn-up.

---

## Clear the LOF (BITS) Alarm

- 
- Step 1** Verify that the line framing and line coding match between the BITS input and the TCC2/TCC2P card:
- a. In node or card view, note the slot and port reporting the alarm.
  - b. Find the coding and framing formats of the external BITS timing source. The formats should be in the user documentation for the external BITS timing source or on the timing source itself.
  - c. In node view (single-shelf mode) or shelf view (multishelf mode), click the **Provisioning > Timing > BITS Facilities** tabs.
  - d. Verify that the Coding setting matches the coding of the BITS timing source, either B8ZS or AMI.
  - e. If the coding does not match, click **Coding** and choose the appropriate coding from the drop-down list.
  - f. Verify that Framing matches the framing of the BITS timing source, either ESF or SF (D4).
  - g. If the framing does not match, click **Framing** and choose the appropriate framing from the drop-down list.



**Note**

On the timing subtab, the B8ZS coding field is normally paired with ESF in the Framing field and the AMI coding field is normally paired with SF (D4) in the Framing field.

---

- Step 2** If the alarm does not clear when the line framing and line coding match between the BITS input and the TCC2/TCC2P card, complete the [“Physically Replace a Card” procedure on page 2-244](#) for the TCC2/TCC2P card.

- Step 3** If the alarm does not clear, log into the Technical Support Website at <http://www.cisco.com/techsupport> for more information or call Cisco TAC (1-800-553-2447) in order to report a Service-Affecting (SA) problem.
- 

## 2.5.153 LOF (TRUNK)

Default Severity: Critical (CR), Service-Affecting (SA)

Logical Object: TRUNK, OCN

The Loss of Frame for the DWDM trunk applies to the trunk optical or electrical signal that is carried to TXP\_MR\_10G, TXP\_MR\_2.5G, TXPP\_MR\_2.5G, TXP\_MR\_10E, TXP\_MR\_10E\_C, TXP\_MR\_10E\_L, MXP\_2.5G\_10G, ADM-10G and OTU2\_XP cards. It indicates that the receiving ONS system has lost frame delineation in the incoming data from trunk that serves the cards. LOF occurs when the SONET overhead loses a valid framing pattern for 3 milliseconds. Receiving two consecutive valid A1/A2 framing patterns clears the alarm.



**Note**

In R7.01, when an LOF alarm occurs on TXP or MXP trunks, G709/SONET/SDH TCAs are suppressed. For details, see the “Alarm and TCA Monitoring and Management” chapter in the *Cisco ONS 15454 DWDM Reference Manual*.

---

### Clear the LOF (TRUNK) Alarm

---

- Step 1** Using site practices, verify fiber continuity to the port. Refer to the “Network Reference” chapter of the *Cisco ONS 15454 DWDM Reference Manual* for a procedure to detect a fiber cut.
- Step 2** If the cabling is good, verify that the correct port is in service by completing the following steps:
- Confirm that the LED is correctly illuminated on the physical card. A green ACT/SBY LED indicates an active card. An amber ACT/SBY LED indicates a standby card.
  - To determine whether the port is in service, in node view (single-shelf mode) or shelf view (multishelf mode), double-click the card in CTC to open the card view.
  - Click the **Provisioning > Line** tabs.
  - Verify that the Admin State column lists the port as IS (or Unlocked).
  - If the Admin State column lists the port as OOS,MT (or Locked,maintenance) or OOS,DSBLD (or Locked,disabled), click the column and choose **IS** , or **Unlocked**.
  - Click **Apply**.
- Step 3** If the correct port is in service, clean the fiber according to site practice. If no site practice exists, complete the fiber cleaning procedure in the “Maintain the Node” chapter of the *Cisco ONS 15454 DWDM Procedure Guide*.
- Step 4** If the alarm does not clear, verify that the power level of the optical signal is within the TXP or MXP card receiver specifications. (These specifications are listed in the “Hardware Specifications” appendix of the *Cisco ONS 15454 DWDM Reference Manual*.)
- Step 5** If the optical power level is within specifications, use an optical test set to verify that a valid signal exists on the line. For specific procedures to use the test set equipment, consult the manufacturer. Test the line as close to the receiving card as possible.

- Step 6** If a valid signal exists, replace the connector on the backplane.
- Step 7** Repeat Steps 1 to 6 for any other port on the card reporting the LOF.
- Step 8** If the alarm does not clear, look for and troubleshoot any other alarm that could identify the source of the problem.
- Step 9** If no other alarms exist that could be the source of the LOF, or if clearing an alarm did not clear the LOF, complete the “[Physically Replace a Card](#)” procedure on page 2-244 for the reporting card.
- Step 10** If the alarm does not clear, or if you need assistance conducting network troubleshooting tests, call Cisco TAC (1-800-553-2447) to report a Service-Affecting (SA) problem.
- 

## 2.5.154 LOGBUFR90

Default Severity: Minor (MN), Non-Service-Affecting (NSA)

Logical Object: SYSTEM

The Log Buffer Over 90 alarm indicates that the per-NE queue of incoming alarm, event, or update capacity of 5000 entries is over 90 percent full. LOGBUFR90 will clear if CTC recovers. If it does not clear, LOGBUFROVFL occurs.



**Note**

LOGBUFR90 is an informational alarm and does not require troubleshooting.

---

## 2.5.155 LOGBUFROVFL

Default Severity: Minor (MN), Non-Service-Affecting (NSA)

Logical Object: SYSTEM

The Log Buffer Overflow alarm indicates that the CTC per-NE queue of incoming alarm, event, or updates, which has a capacity of 5,000 entries, has overflowed. This happens only very rarely. However if it does, you must restart the CTC session. It is likely that some updates will have been missed if this alarm occurs.

### Clear the LOGBUFROVFL Alarm

- Step 1** Restart the CTC session.s
- Step 2** If the alarm does not clear, log into the Technical Support Website at <http://www.cisco.com/techsupport> for more information or call TAC (1-800-553-2447).
- 

## 2.5.156 LO-LASERBIAS

Default Severity: Minor (MN), Non-Service-Affecting (NSA)

Logical Objects: EQPT, OCN/STMN, PPM



The Equipment Low Transmit Laser Bias Current alarm is raised against the TXP and MXP card laser performance. The alarm indicates that the card laser has reached the minimum laser bias tolerance.

If the LO-LASERBIAS alarm threshold is set at 0 percent (the default), the laser's usability has ended. If the threshold is set at 5 percent to 10 percent, the card is still usable for several weeks or months before you need to replace it.

**Note**

For general information about MXP and TXP cards, refer to the “Card Reference” chapter in the *Cisco ONS 15454 DWDM Reference Manual*. For information about provisioning them, refer to the “Provision Transponder and Muxponder Cards” chapter in the *Cisco ONS 15454 DWDM Procedure Guide*.

## Clear the LO-LASERBIAS Alarm

- 
- Step 1** Complete the “[Physically Replace a Card](#)” procedure on page 2-244.
- Step 2** If the alarm does not clear, log into the Technical Support Website at <http://www.cisco.com/techsupport> for more information or call Cisco TAC (1-800-553-2447).
- 

## 2.5.157 LO-LASERTEMP

Default Severity: Minor (MN), Non-Service-Affecting (NSA)

Logical Objects: EQPT, OCN/STMN, PPM

The Equipment Low Laser Optical Transceiver Temperature alarm applies to the TXP and MXP cards. LO-LASERTEMP occurs when the internally measured transceiver temperature falls below the card setting by 35.6 degrees F or 2 degrees C. A laser temperature change affects the transmitted wavelength. (This temperature is equivalent to about 200 picometers of wavelength.)

When the TXP or MXP card raises this alarm, the laser is automatically shut off. The An LOS for OCN/STMN is raised at the far-end node and the “[DUP-IPADDR](#)” alarm on page 2-65 is raised at the near end. (Both of these alarms are described in the “Alarm Troubleshooting” chapter of the *Cisco ONS 15454 Troubleshooting Guide* or the *Cisco ONS 15454SDH Troubleshooting Guide*). To verify the card laser temperature level, double-click the card in node view (single-shelf mode) or shelf view (multishelf mode) and click the **Performance > Optics PM > Current Values** tabs. Maximum, minimum, and average laser temperatures are shown in the Current column entries in the Laser Temp rows.

**Note**

For general information about MXP and TXP cards, refer to the “Card Reference” chapter in the *Cisco ONS 15454 DWDM Reference Manual*. For information about provisioning them, refer to the “Provision Transponder and Muxponder Cards” chapter in the *Cisco ONS 15454 DWDM Procedure Guide*.

## Clear the LO-LASERTEMP Alarm

- 
- Step 1** In node view (single-shelf mode) or shelf view (multishelf mode), complete the “[Reset a Card in CTC](#)” procedure on page 2-241 for the reporting MXP or TXP card.

- Step 2** If the alarm does not clear, complete the “[Physically Replace a Card](#)” procedure on page 2-244 for the reporting MXP or TXP card.
- Step 3** If the alarm does not clear, log into the Technical Support Website at <http://www.cisco.com/techsupport> for more information or call Cisco TAC (1-800-553-2447).

## 2.5.158 LOM

Default Severity: Critical (CR), Service-Affecting (SA)

Logical Object: TRUNK, EQPT

The Optical Transport Unit (OTU) Loss of Multiframe alarm is an OTN alarm for the trunk port and occurs when the Multi Frame Alignment Signal (MFAS) is corrupted. The alarm applies to MXP\_2.5G\_10G, TXP\_MR\_10G, TXP\_MR\_2.5G, TXP\_MR\_10E, TXP\_MR\_10E\_C, TXP\_MR\_10E\_L, TXPP\_MR\_2.5G, ADM-10G, and OTU2\_XP cards when the MFAS) overhead field is errored for more than five frames and persists for more than 3 milliseconds.



### Note

For general information about MXP and TXP cards, refer to the “Card Reference” chapter in the *Cisco ONS 15454 DWDM Reference Manual*. For information about provisioning them, refer to the “Provision Transponder and Muxponder Cards” chapter in the *Cisco ONS 15454 DWDM Procedure Guide*.

## Clear the LOM Alarm

- Step 1** Ensure that the fiber connector for the card is completely plugged in. For more information about fiber connections and card insertion, refer to the “Turn Up a Node” chapter in the *Cisco ONS 15454 DWDM Procedure Guide*.
- Step 2** If the bit error rate (BER) threshold is correct and at the expected level, use an optical test set to measure the power level of the line to ensure it is within guidelines. For specific procedures to use the test set equipment, consult the manufacturer.
- Step 3** If the optical power level is good, verify that optical receive levels are within the acceptable range. Ranges for ONS 15454 DWDM cards are located in the “Hardware Specifications” appendix of the *Cisco ONS 15454 DWDM Reference Manual*.
- Step 4** If receive levels are good, clean the fibers at both ends according to site practice. If no site practice exists, complete the fiber cleaning procedure in the “Maintain the Node” chapter in the *Cisco ONS 15454 DWDM Procedure Guide*.
- Step 5** If the condition does not clear, verify that single-mode fiber is used.
- Step 6** If the fiber is of the correct type, verify that a single-mode laser is used at the far-end node.
- Step 7** Clean the fiber connectors at both ends for a signal degrade according to site practice.
- Step 8** Verify that a single-mode laser is used at the far end.
- Step 9** If the problem does not clear, the transmitter at the other end of the optical line could be failing and require replacement. Refer to the “[2.8.4 Physical Card Reseating, Resetting, and Replacement](#)” section on page 2-242.

- Step 10** If the alarm does not clear, log into the Technical Support Website at <http://www.cisco.com/techsupport> for more information or call Cisco TAC (1-800-553-2447) in order to report a Service-Affecting (SA) problem.
- 

## 2.5.159 LOP-P

Default Severity: Critical (CR), Service-Affecting (SA)

Logical Object: STSMON, STSTRM

A Loss of Pointer Path alarm indicates that the SONET path pointer in the overhead has been lost. LOP occurs when valid H1/H2 pointer bytes are missing from the overhead. Receiving equipment monitors the H1/H2 pointer bytes to locate the SONET payload. An LOP-P alarm occurs when eight, nine, or ten consecutive frames do not have valid pointer values. The alarm clears when three consecutive valid pointers are received.

The LOP-P alarm can occur when the received payload does not match the provisioned payload. The alarm is caused by a circuit type mismatch on the concatenation facility. For example, if an STS-1 is sent across a circuit provisioned for STS-3c, an LOP-P alarm occurs.

For the FC\_MR-4 card, an LOP-P is raised if a port is configured for a SONET signal but receives an SONET signal instead. (This information is contained in the H1 byte bits 5 and 6.)

### Clear the LOP-P Alarm



**Caution**

Always use the supplied electrostatic discharge wristband when working with a powered ONS 15454. Plug the wristband cable into the ESD jack located on the lower-right edge of the shelf assembly.

---

- Step 1** In node view, click the **Circuits** tab and view the alarmed circuit.
- Step 2** Verify the circuit size listed in the Size column. If the size is different from what is expected, such as an STS3c instead of an STS1, this causes the alarm.
- Step 3** If you have been monitoring the circuit with optical test equipment, a mismatch between the provisioned circuit size and the size expected by the test set can cause this alarm. For specific procedures to use the test set equipment, consult the manufacturer. Ensure that the test set monitoring is set up for the same size as the circuit provisioning.
- Refer to the manufacturer's instructions for test-set use.
- Step 4** If the error is not due to an incorrectly configured test set, the error is in the provisioned CTC circuit size. Complete the [“Delete a Circuit” procedure on page 2-245](#).
- Step 5** Recreate the circuit for the correct size. For procedures, refer to the “Create Circuits and VT Tunnels” chapter in the *Cisco ONS 15454 Procedure Guide*.
- Step 6** If the alarm does not clear, log into the Technical Support Website at <http://www.cisco.com/techsupport> for more information or call Cisco TAC (1-800-553-2447) in order to report a Service-Affecting (SA) problem.
-

## 2.5.160 LO-RXPOWER

Default Severity: Minor (MN), Non-Service-Affecting (NSA)

Logical Objects: 2R, ESCON, FC, GE, ISC, OCN/STMN, TRUNK

The Equipment Low Receive Power alarm is an indicator for TXP\_MR\_10G, TXP\_MR\_2.5G, TXPP\_MR\_2.5G, TXP\_MR\_10E, TXP\_MR\_10E\_C, TXP\_MR\_10E\_L, MXP\_2.5G\_10G, OC192-XFP, ADM-10G, and OTU2\_XP card received optical signal power. LO-RXPOWER occurs when the measured optical power of the received signal falls below the threshold value, which is user-provisionable.



### Note

For general information about MXP and TXP cards and their necessary levels, refer to the “Card Reference” chapter and the “Hardware Specifications” appendix in the *Cisco ONS 15454 DWDM Reference Manual*.

## Clear the LO-RXPOWER Alarm

- 
- Step 1** Check the PM of the TRUNK-RX port. Verify that received power is above the optics threshold:
- In node view (single-shelf mode) or shelf view (multishelf mode), double-click the card to display the card view.
  - For the TRUNK-RX port, double-click the card and click the **Performance > Optics PM > Historical PM** tabs, choose the port in the **Port** drop-down list, and click **Refresh**.
  - Compare the refreshed PM values with the threshold (ensuring that they are above the threshold value) by clicking the **Performance > Optics PM > Current Values** tabs.
  - Ensure that a proper threshold has been provisioned for the receive value. (Refer to the “Provision Transponder and Muxponder Cards” chapter in the *Cisco ONS 15454 DWDM Procedure Guide*.) If an incorrect threshold has been set, adjust it to a value within the allowed limits. If instead the alarm condition does not clear, move to next step.
- Step 2** Verify that the Trunk-Rx port is cabled correctly, and clean the fiber connecting the faulty TXP/MXP to the Drop port of the DWDM card (32DMX, 32DMX-O, 40DMX, or AD-xC-xx.x). If no site cleaning practices are available, refer to the “Maintain the Node” chapter of the *Cisco ONS 15454 DWDM Procedure Guide*.
- Step 3** Determine whether a bulk attenuator is specified by the Cisco TransportPlanner design. If so, verify that the proper fixed attenuation value has been used.
- Step 4** Using a test set, check the optical power value of the Drop port of the DWDM card (32DMX, 32DMX-O, 40DMX, or AD-xC-xx.x) connected to the faulty TXP/MXP. If the read value is different (+1 dBm or –1 dBm) from the ANS setpoint for “Padd&drop-Drop power,” move to next step. If not, complete the [“Physically Replace a Card”](#) section on page 2-244.
- Step 5** Look for any alarm reported by the DWDM cards belonging to the OCHNC circuit whose destination is the faulty TXP/MXP and first troubleshoot that alarm. Possible alarm related include: amplifier Gain alarms (the [“GAIN-HDEG”](#) alarm on page 2-90, the [“GAIN-HFAIL”](#) alarm on page 2-91, the [“GAIN-LDEG”](#) alarm on page 2-91, or [“GAIN-LFAIL”](#) alarm on page 2-92); APC alarms (the [“APC-CORR-SKIPPED”](#) alarm on page 2-29 or [“APC-OUT-OF-RANGE”](#) alarm on page 2-31), and LOS-P alarms on the Add or Drop ports belonging to the OCHNC circuit.

- Step 6** If the alarm does not clear, log into the Technical Support Website at <http://www.cisco.com/techsupport> for more information or call Cisco TAC (1-800-553-2447).
- 

## 2.5.161 LOS (2R)

Default Severity: Critical (CR), Service-Affecting (SA)

Logical Object: 2R

The Loss of Signal for a 2R client applies to TXP\_MR\_10G, TXP\_MR\_2.5G, TXPP\_MR\_2.5G, TXP\_MR\_10E, TXP\_MR\_10E\_C, TXP\_MR\_10E\_L, and MXP\_2.5G\_10G cards. The alarm is raised when the card port is not receiving input. An AIS is sent upstream.



### Caution

Always use the supplied electrostatic discharge wristband when working with a powered ONS system. Plug the wristband cable into the ESD jack located on the lower-right edge of the shelf assembly. To verify cable continuity, follow site practices.

---



### Note

For general information about MXP and TXP cards, refer to the “Card Reference” chapter in the *Cisco ONS 15454 DWDM Reference Manual*.

---

## Clear the LOS (2R) Alarm

- Step 1** Ensure that the signal entering the Client-Rx port is provisioned with the correct physical-layer protocol.
- Step 2** Ensure that the signal feeding the Client-Rx port is provisioned with the correct line speed.
- Step 3** Check the PM of the Client-Rx port.
- Step 4** Verify that received power is above the optics threshold.
- Step 5** Ensure that a proper threshold has been provisioned. (Refer to the “Provision Transponder and Muxponder Cards” chapter in the *Cisco ONS 15454 DWDM Procedure Guide*. Refer to the SFP/XFP plug-in specifications located in the “Hardware Specifications” appendix of the *Cisco ONS 15454 DWDM Reference Manual*.) If an incorrect threshold has been set, adjust it to a value within the allowed limits.
- Step 6** Verify the proper cabling and clean the fibers according with the site practice. Cabling procedures are located in the “Turn Up a Node” chapter of the *Cisco ONS 15454 DWDM Procedure Guide*, and a fiber-cleaning procedure is located in the “Maintain the Node” chapter of the same guide.
- Step 7** Verify using an optical test set that a valid signal exists on the line and feeds the Client-Rx port. (For specific procedures to use the test set equipment, consult the manufacturer.) Test the line as close to the receiving card as possible. If the alarm condition does not clear, move to next step.
- Step 8** Complete the “[Install an SFP or XFP Connector](#)” procedure on page 1-59 or the “[Physically Replace a Card](#)” procedure on page 2-244 as appropriate for your purposes.
- Step 9** If the alarm does not clear, log into the Technical Support Website at <http://www.cisco.com/techsupport> for more information or call Cisco TAC (1-800-553-2447) to report a Service-Affecting (SA) problem.
-

## 2.5.162 LOS (BITS)

Default Severity: Minor (MN), Non-Service-Affecting (NSA)

Logical Object: BITS

The LOS (BITS) alarm indicates that the TCC2/TCC2P card has an LOS from the BITS timing source. LOS for BITS means the BITS clock or the connection to it failed.

### Clear the LOS (BITS) Alarm



**Caution**

Always use the supplied electrostatic discharge wristband when working with a powered ONS system. Plug the wristband cable into the ESD jack located on the lower-right edge of the shelf assembly.

- 
- Step 1** Verify the wiring connection from the BITS clock pin fields on the ONS system backplane to the timing source.
- Step 2** If wiring is good, verify that the BITS clock is operating properly.
- Step 3** If the alarm does not clear, log into the Technical Support Website at <http://www.cisco.com/techsupport> for more information or call Cisco TAC (1-800-553-2447) in order to report a Service-Affecting (SA) problem.
- 

## 2.5.163 LOS (ESCON)

Default Severity: Critical (CR), Service-Affecting (SA)

Logical Object: ESCON

The ESCON LOS alarm occurs on the TXP\_MR\_2.5G or TXPP\_MR\_2.5G card when there is a loss of signal for this payload, usually due to a physical error such as incorrect cabling connections, faulty cabling, or a break. It can also be caused by an incorrectly configured SFP.

### Clear the LOS (ESCON) Alarm

- 
- Step 1** Check for any upstream equipment failures that could cause the ESCON LOS alarm in this node.
- Step 2** If there is no cause upstream, verify cabling continuity from the transmitting port to the receiving port reporting this LOS. To verify cable continuity, follow site practices.



**Caution**

Always use the supplied electrostatic discharge wristband when working with a powered ONS system. Plug the wristband cable into the ESD jack located on the lower-right edge of the shelf assembly.

- 
- Step 3** If the continuity is good, clean the fiber according to site practice. If none exists, complete the fiber-cleaning procedure in the “Maintain the Node” chapter in the *Cisco ONS 15454 DWDM Procedure Guide*.

- Step 4** Ensure that the PPM (SFP) is correctly configured for this payload:
- In node view (single-shelf mode) or shelf view (multishelf mode), double-click the card to open the card view.
  - Click the **Provisioning > Pluggable Port Modules** tabs.
  - Check the **Pluggable Port Modules** area for the PPM (SFP) associated with the port.
  - In the Pluggable Ports area, ensure that the rate for the errored PPM (SFP) is ESCON.



**Note** For information about provisioning PPMs (SFPs), refer to the “Turn Up a Node” chapter in the *Cisco ONS 15454 DWDM Procedure Guide*. PPM (SFP) specifications are listed in the “Hardware Specifications” appendix of the *Cisco ONS 15454 DWDM Reference Manual*.

- Step 5** If the physical cabling and PPM (SFP) are good but the alarm does not clear, verify that the correct port is actually in service:
- Confirm that the LED is correctly lit on the physical TXP card.  
A green ACT/SBY LED indicates an active card. An amber ACT/SBY LED indicates a standby card.
  - To determine whether the port is in service, double-click the card in CTC to open the card view.
  - Click the **Provisioning > Line** tabs.
  - Verify that the Admin State column lists the port as IS (or Unlocked).
  - If the Admin State column lists the port as OOS,MT (or Locked,maintenance) or OOS,DSBLD (or Locked,disabled), click the column and choose **IS** , or **Unlocked**. Click **Apply**.
- Step 6** If the correct port is in service but the alarm has not cleared, use an optical test set to confirm that a valid signal exists on the line. For specific procedures to use the test set equipment, consult the manufacturer. Test the line as close to the receiving card as possible.
- Step 7** If the signal is valid, ensure that the transmit and receive outputs from the patch panel to your equipment are properly connected. For more information about fiber connections and terminations, refer to the “Turn Up a Node” chapter in the *Cisco ONS 15454 DWDM Procedure Guide*.
- Step 8** If a valid signal exists but the alarm does not clear, replace the cable connector on the ONS system.
- Step 9** Repeat Steps 2 through 6 for any other port on the card that reports the LOS (ESCON).
- Step 10** If the alarm does not clear, the cabling could still be faulty despite correct attachments. Use the test set to locate the bad cable and replace it using the procedures in the “Manage the Node” chapter in the *Cisco ONS 15454 DWDM Procedure Guide*.
- Step 11** If the alarm does not clear, look for any card-level alarm that could cause this port alarm.
- Step 12** If the alarm does not clear, complete the [“Physically Replace a Card” procedure on page 2-244](#) for the reporting card.
- Step 13** If the alarm does not clear, log into the Technical Support Website at <http://www.cisco.com/techsupport> for more information or call Cisco TAC (1-800-553-2447) in order to report a Service-Affecting (SA) problem.

## 2.5.164 LOS (ISC)

Default Severity: Critical (CR), Service-Affecting (SA)

Logical Object: ISC

The LOS alarm for the ISC port applies to TXPP\_MR\_2.5G or TXP\_MR\_2.5G client PPMs (SFPs) provisioned at the ISC port rate. Troubleshooting is similar to the LOS (2R) alarm.



**Note**

For general information about MXP and TXP cards, refer to the “Card Reference” chapter in the *Cisco ONS 15454 DWDM Reference Manual*. For information about provisioning them, refer to the “Provision Transponder and Muxponder Cards” chapter in the *Cisco ONS 15454 DWDM Procedure Guide*.

## Clear the LOS (ISC) Alarm



**Caution**

Always use the supplied electrostatic discharge wristband when working with a powered ONS system. Plug the wristband cable into the ESD jack located on the lower-right edge of the shelf assembly.

**Step 1** Complete the “[Clear the LOS \(2R\) Alarm](#)” procedure on page 2-133.

**Step 2** If the alarm does not clear, log into the Technical Support Website at <http://www.cisco.com/techsupport> for more information or call Cisco TAC (1-800-553-2447) in order to report a Service-Affecting (SA) problem.

## 2.5.165 LOS (OTS)

Default Severity: Critical (CR), Service-Affecting (SA)

Logical Object: OTS

The Loss of Signal for the OTS applies to the OSC-3-RX port of the OPT-BST or OPT-AMP-x-C amplifier cards and the LINE-2-RX port of the OSCM or OSC-CSM card. It indicates that a fiber cut has occurred and no power is being received from the span. The alarm is raised when both LOS-P and LOS-O alarms occur, and demotes them.

## Clear the LOS (OTS) Alarm

**Step 1** To troubleshoot this alarm, see the “[1.12.1 Fiber Cut Detection](#)” section on page 1-61.

**Step 2** If the alarm does not clear, log into the Technical Support Website at <http://www.cisco.com/techsupport> for more information or call Cisco TAC (1-800-553-2447) in order to report a Service-Affecting (SA) problem.

## 2.5.166 LOS (TRUNK)

Default Severity: Critical (CR), Service-Affecting (SA)

Logical Object: TRUNK



The Loss of Signal (LOS) for a TRUNK applies to GE-XP, 10GE-XP, TXP\_MR\_10G, TXP\_MR\_2.5G, TXPP\_MR\_2.5G, TXP\_MR\_10E, TXP\_MR\_10E\_C, TXP\_MR\_10E\_L, MXP\_2.5G\_10G, ADM-10G, and OTU2\_XP cards.



**Note** The MXP\_2.5G\_10E card has no LOS (TRUNK) option, because G.709 cannot be disabled on the card.

The alarm is raised when the card port is not receiving input. An AIS is sent upstream.

The purpose of the LOS (TRUNK) alarm is to alert the user that no optical power is being received from the fiber. A typical fault condition signalled by the LOS (TRUNK) alarm is a fiber cut. In this case, neither the payload nor the overhead signals are being received.



**Note** With G.709 off, the alarm coming from the trunk is LOS (TRUNK) in accordance with SONET standards.



**Note** In R7.01, when an LOS (TRUNK) alarm occurs on TXP and MXP trunks, G709/SONET/SDH TCAs are suppressed. For details, see the “Alarm and TCA Monitoring and Management” chapter in the *Cisco ONS 15454 DWDM Reference Manual*.



**Note** For general information about MXP and TXP cards, refer to the “Card Reference” chapter in the *Cisco ONS 15454 DWDM Reference Manual*. For information about provisioning them, refer to the “Provision Transponder and Muxponder Cards” chapter in the *Cisco ONS 15454 DWDM Procedure Guide*.

## Clear the LOS (TRUNK) Alarm

- Step 1** Check the PMs of the TRUNK-RX port and verify that the received power is above the optics threshold.
- Step 2** Check that a proper threshold has been provisioned. (For procedures, refer to the “Provision Transponder and Muxponder Cards” chapter in the *Cisco ONS 15454 DWDM Procedure Guide*.) If an incorrect threshold has been set, adjust it to a value within the allowed limits. If the alarm condition does not clear, move to next step.
- Step 3** Verify the cabling of the Trunk-Rx port and clean the fiber connecting the faulty TXP/MXP to the Drop port of the DWDM card (32DMX, 32DMX-O, 40DMX, or AD-xC-xx.x). For fiber cleaning procedures, refer to the “Maintain the Node” chapter of the *Cisco ONS 15454 DWDM Procedure Guide*.
- Step 4** Using an optical test set, verify that a valid signal exists on the line and feeds the TRUNK-RX port. (For specific procedures to use the test set equipment, consult the manufacturer.) Test the line as close to the receiving card as possible. If the alarm condition does not clear, move to next step.
- Step 5** Verify whether a bulk attenuator is specified in the Cisco TransportPlanner design. If so, verify that the proper fixed attenuation value has been used.
- Step 6** Check the Drop port optical power value of the DWDM card (32DMX, 32DMX-O, 40DMX, or AD-xC-xx.x) connected to the faulty TXP/MXP. If the read value is different (+1 dBm or -1 dBm) compared to the ANS setpoint “Padd&drop-Drop power,” move to next step. If not, complete the [“Physically Replace a Card” procedure on page 2-244](#).

- Step 7** If the alarm does not clear after the replacement, log into the Technical Support Website at <http://www.cisco.com/techsupport> for more information or call Cisco TAC (1 800 553-2447) in order to report a Service-Affecting (SA) problem.
- Step 8** Look for and troubleshoot any alarms reported by the DWDM cards belonging to the OCHNC circuit whose destination is the faulty TXP/MXP. Possible alarms include: amplifier gain alarms (the “GAIN-HDEG” alarm on page 2-90, the “GAIN-HFAIL” alarm on page 2-91, the “GAIN-LDEG” alarm on page 2-91 or “GAIN-LFAIL” alarm on page 2-92); APC alarms (the “APC-CORR-SKIPPED” alarm on page 2-29 and “APC-OUT-OF-RANGE” alarm on page 2-31), OR LOS-P alarms on the Add or Drop ports belonging to the OCHNC circuit.
- Step 9** If the alarm does not clear, log into the Technical Support Website at <http://www.cisco.com/techsupport> for more information or call Cisco TAC (1 800 553-2447) in order to report a Service-Affecting (SA) problem.
- 

## 2.5.167 LOS-0

Default Severity: Minor (MN), Non-Service-Affecting (NSA)

Logical Objects: OCH, OMS, OTS

The Incoming Overhead Loss of Signal alarm applies to the OSC-TX port of OPT-BST or OPT-AMP-x-C cards (LINE-1-RX), the OSC-RX internal optical port of OSC-CSM card (LINE-3-RX Port 3). It is raised when the monitored input power crosses the FAIL-LOW threshold associated to the OSC Power received. The is alarm is demoted if another LOS alarm is also present.

### Clear the LOS-0 Alarm

- Step 1** Verify fiber continuity to the port by following site practices. Refer to the “Network Reference” chapter of the *Cisco ONS 15454 DWDM Reference Manual* for a procedure to detect a fiber cut.
- Step 2** If the cabling is good, confirm that the LED is correctly illuminated on the physical card. A green ACT/SBY LED indicates an active card. A red ACT/SBY LED indicates a failed card.
- Step 3** Display the optical thresholds by clicking one of the following tabs:
- For the OPT-BST or OPT-AMP-x-C cards, click the **Provisioning > Opt. Ampli. Line > Optics Thresholds** tabs and click the Alarm checkbox in the Type panel.
  - For the OSC-CSM cards, click the **Provisioning > Optical Line > Optics Thresholds** tabs.
- Step 4** Verify that OSC Fail Low thresholds are correct according with Cisco TransportPlanner configuration file. To identify the MP value:
- a. In node view (single-shelf mode) or shelf view (multishelf mode), click the **Provisioning > WDM-ANS > Provisioning** tabs.
  - b. Identify the following parameter: east or west side Rx channel OSC LOS threshold.
- Step 5** If the port power is below the threshold, verify that OSC connections have been created on the other side of the span. If the connections are not present, refer to the “Provision Channels and Circuits” chapter of the *Cisco ONS 15454 DWDM Procedure Guide* for procedures.
- Step 6** If OSC connections are present, check the OSC transmitted power using CTC on the far-end node. Refer to the “TurnUp Node” chapter of the *Cisco ONS 15454 DWDM Procedure Guide* for the proper procedure.

- Step 7** If the transmitted OSC value is out of range, troubleshoot that problem first.
- Step 8** If the OSC value is within range, come back to the port reporting the LOS-O alarm and clean the fiber according to site practice. If no site practice exists, complete the fiber-cleaning procedure in the “Maintain the Node” chapter of the *Cisco ONS 15454 DWDM Procedure Guide*.
- Step 9** If the alarm does not clear, look for and troubleshoot any other alarm that could identify the source of the problem.
- Step 10** If no other alarms exist that could be the source of the LOS-O, place all of the card ports in **OOS,DSBLD** (or **Locked,disabled**) administrative state.
- Step 11** Complete the “[Physically Replace a Card](#)” procedure on page 2-244 for the reporting card.
- Step 12** If the alarm does not clear, log into the Technical Support Website at <http://www.cisco.com/techsupport> for more information or call Cisco TAC (1-800-553-2447).

## 2.5.168 LOS-P (AOTS, OMS, OTS)

Default Severity: Critical (CR), Service-Affecting (SA)

Logical Objects: AOTS, OMS, OTS

The Loss of Signal for Optical Channel alarm (OMS and OTS layer) applies to all input ports of the following DWDM cards: AD-1B-xx.x, AD-4B-xx.x, 32DMX, 32DMX-O, 40DMX-C, 40DMX-CE, OPT-PRE, OPT-BST, OPT-AMP-C, OPT-AMP-17-C, and OSC-CSM.

For AD-1C-xx.x, AD-2C-xx.x, AD-4C-xx.x, 32MUX-O, 32WSS, 40WSS-C, and WXC cards, this alarm applies only to the input ports where an aggregate signal is managed, such as the COM-RX, EXP-RX, or xxBAND-RX ports). These ports are solely used for the AOTS, OMS, and OTS layers.

LOS-P (AOTS, OMS, or OTS) indicates a loss of receive signal, which means that the monitored input power value has crossed the Power Failure Low Threshold associated to the port.



### Note

When the LOS-P alarm is raised on the LINE-RX port of the OPT-BST, OPT-AMP-x-C, or OSC-CSM card, it can indicate a fiber cut. Refer to the “Network Reference” chapter of the *Cisco ONS 15454 DWDM Reference Manual* for a fiber cut detection procedure.



### Note

When the LOS-P alarm is raised on the COM-RX port of the 32DMX-C, 32DMX-L, 40DMX-C, 40-DMX-CE, or WXC cards, it can indicate the presence of undesirable counter-propagating light entering the card from the drop ports. The counter-propagating light can be inserted into these cards as a result of incorrect cabling of transponder or line cards to the fiber patch-panel (in particular, swapping RX with TX patchcords). This behavior is only applicable to optical modules with vendor IDs 2049, 2050, 2304, and 2306. You can view the vendor IDs at **CTC > Card View > Inventory** tab.

## Clear the LOS-P (AOTS, OMS, OTS) Alarm

- Step 1** Verify that the card has the correct physical behavior by checking the LED on the physical card. A green ACT/SBY LED indicates an active card, and a red ACT/SBY LED indicates a failed card. If the LED is red, complete the “[Physically Replace a Card](#)” procedure on page 2-244 and continue to [Step 8](#).

**Note**

When you replace a card with an identical type of card, you do not need to make any changes to the database other than restoring the card's port to the IS, AINS or Unlocked, automatic InService administrative state.

- Step 2** Verify that there truly is a loss of input signal by completing the following steps:
- a. In node view (single-shelf mode) or shelf view (multishelf mode), double-click the card to open the card view.
  - b. Verify the proper input power values by clicking one of the following tabs as appropriate:
    - For the OPT-BST, OPT-AMP-C, and OPT-AMP-17-C cards, click the **Provisioning > Optical Line > Parameters** tabs.
    - For the OPT-PRE, OPT-AMP-C, and OPT-AMP-17-C cards, click the **Provisioning > Optical Line > Parameters** tabs.
    - For the AD-xC-xx.x card, click the **Provisioning > Optical Line > Parameters** tabs.
    - For the AD-xB-xx.x card, click the **Provisioning > Optical Band > Parameters** tabs.
    - For the 32MUX-O and 40MUX cards, click the **Provisioning > Optical Line > Parameters** tabs.
    - For the 32WSS and 40WSS-C cards, click the **Provisioning > Optical Line > Parameters** tabs.
    - For the 32DMX-O card, click the **Provisioning > Optical Line > Parameters** tabs.
    - For the 32DMX and 40DMX cards, click the **Provisioning > Optical Line > Parameters** tabs.
    - For the OSC-CSM card, click the **Provisioning > Optical Line > Parameters** tabs.
  - c. Display the proper Power Failure Low threshold by clicking one of the following tabs as appropriate:
    - For the OPT-BST, OPT-AMP-C, and OPT-AMP-17-C cards, click the **Provisioning > Optical Line > Optics Thresholds** tabs.
    - For the OPT-BST, OPT-AMP-C, and OPT-AMP-17-C cards, click the **Provisioning > Optical Line > Optics Thresholds** tabs.
    - For the AD-xC-xx.x card, click the **Provisioning > Optical Line > Optics Thresholds** tabs.
    - For the AD-xB-xx.x card, click the **Provisioning > Optical Band > Optics Thresholds** tabs.
    - For the AD-xB-xx.x card, click the **Provisioning > Optical Line > Optics Thresholds** tabs.
    - For the 32MUX-O and 40MUX cards, click the **Provisioning > Optical Line > Optics Thresholds** tabs.
    - For the 32WSS and 40WSS-C cards, click the **Provisioning > Optical Line > Optics Thresholds** tabs.
    - For the 32DMX-O card, click the **Provisioning > Optical Line > Optics Thresholds** tabs.
    - For the 32DMX and 40DMX, click the **Provisioning > Optical Line > Optics Thresholds** tabs.
    - For the OSC-CSM card, click the **Provisioning > Optical Line > Optics Thresholds** tabs.

**Tip**

To view the alarm thresholds (as opposed to the warning thresholds), check the **Alarm** check box on the bottom-left of the Optics Thresholds tab and click **Reset**.

- d. Compare the actual Power value with the Alarm Threshold value and complete one of the following actions:

- If the Power value is less than the Fail Low threshold, go to [Step 3](#).
- If the Power value is greater than the Fail Low threshold plus the alarm hysteresis (allowance value) default of 1 dBm, complete the “[Reset a Card in CTC](#)” procedure on page 2-241 for the card.

If the alarm does not clear, complete the “[Physically Replace a Card](#)” procedure on page 2-244 and continue to [Step 8](#).



---

**Note** When you replace a card with an identical type of card, you do not need to make any changes to the database other than restoring the card’s port to the IS,AINS or Unlocked,automaticInService administrative state.

---

- Step 3** Verify the fiber continuity to the port by following site practices. Refer to the “Network Reference” chapter of the *Cisco ONS 15454 DWDM Reference Manual* for a procedure to detect a fiber cut.
- Step 4** Check the “Internal Connections” file generated by Cisco Transport Planner for the node where the errored card is located. If necessary, recable the node cabling in accordance with the MP file connections list. To cable a DWDM node, refer to the “Turn Up a Node” chapter in the *Cisco ONS 15454 DWDM Procedure Guide*.
- Step 5** If the cabling is good, use an optical test set to measure the power value on the output port connected to the alarmed card. For specific procedures to use the test set equipment, consult the manufacturer. If the power difference reported is greater than 1 dBm (standard fiber jumper insertion loss is 0.3 dBm), clean the fiber according to site practice. If no site practice exists, complete the fiber-cleaning procedure in the “Maintain the Node” chapter of the *Cisco ONS 15454 DWDM Procedure Guide*.



---

**Note** Unplugging the fiber can cause a traffic hit. To avoid this, perform a traffic switch if possible. Refer to the “Manage the Node” chapter in the *Cisco ONS 15454 DWDM Procedure Guide* for detailed information.

---

- Step 6** If the port on which the alarm is raised is connected to a remote CRS-1 or ASR 9000 series router, verify that the wavelength configured on the router interface is the same as that configured for the port. Check the router configuration by using these steps:
- Enter the following command on the router to validate the remote node configuration.

```
Router> show controllers dwdm interface id x/x/x/x
```

- Check the information displayed under Optics Status to verify the configured wavelength.
- If the wavelength is different from that configured for the port, reset it by entering the following command on the router in global configuration mode.

```
Router (config)# controller dwdm interface id x/x/x/x wavelength channel number
```



---

**Note** The wavelength configured for the port can be checked in CTC card view.

---

- Step 7** If the alarm does not clear, follow the general troubleshooting rules in the “Network Reference” chapter in the *Cisco ONS 15454 DWDM Reference Manual* for identifying any other upstream alarm in the logical signal flow that could be the root cause of the outstanding alarm.

- Step 8** If the alarm does not clear, log into the Technical Support Website at <http://www.cisco.com/techsupport> for more information or call Cisco TAC (1-800-553-2447) in order to report a service-affecting problem.

## 2.5.169 LOS-P (OCH)

Default Severity: Critical (CR), Service-Affecting (SA)

Logical Object: OCH

The Loss of Signal for Optical Channel alarm on the OCH layer applies to the channel Add or pass-through ports on the AD-1C-xx.x, AD-2C-xx.x, AD-4C-xx.x, 32MUX-O, 40MUX, 32WSS-O, 40WSS-C, GE-XP, 10GE-XP, and ADM-10G DWDM cards.

For the 32WSS-O and 40WSS-C, the LOS-P alarm can be associated with Add ports as well as pass-through internal ports. If the LOS-P (OCH) alarm is raised against this kind of port a different troubleshooting procedure is needed because the port does not have an optical power source directly connected to it. In this case, follow the general troubleshooting rules for network-level (inter-node) troubleshooting in [Chapter 1, “General Troubleshooting,”](#) to identify upstream alarms in the logical signal flow that could cause an LOS-P.

LOS-P (OCH) indicates a loss of received signal, which means the monitored input power value has crossed the Power Failure Low threshold associated with the port in accordance with the specific VOA power reference setpoint provisioned on VOA along the path.



**Note**

For more information about provisioning VOA setpoints, refer to the “Network Reference” chapters of the *Cisco ONS 15454 DWDM Reference Manual*.

### Clear the LOS-P (OCH) Alarm

- Step 1** Verify that the card is exhibiting correct behavior by checking the LED behavior on the physical card. A green ACT/SBY LED indicates an active card, and a red ACT/SBY LED indicates a failed card. If the LED is red, complete the [“Physically Replace a Card”](#) procedure on page 2-244 and continue to [Step 9](#).



**Note**

When you replace a card with an identical type of card, you do not need to make any changes to the database other than restoring the card’s port to the IS,AINS or Unlocked,automaticInService administrative state.

- Step 2** Verify that there truly is a loss of received signal by completing the following steps:
- a. In node view (single-shelf mode) or shelf view (multishelf mode), double-click the card to open the card view.
  - b. View the proper input power values by clicking one of the following tabs as appropriate:
    - For the AD-xC-xx.x card, click the **Provisioning > Optical Chn > Parameters** tabs.
    - For the ADM-10G card, click **Performance > Optics PM > Current Values** tabs.
    - For the 32MUX-O and 40MUX cards, click the **Provisioning > Optical Chn > Parameters** tabs.

- For the 32WSS-O and 40WSS-C cards, click the **Provisioning > Optical Chn: Optical Connector x > Parameters** tabs.
- c. Display the proper Power Failure Low threshold by clicking one of the following tabs as appropriate:
- For the AD-xC-xx.x card, click the **Provisioning > Optical Chn > Optics Thresholds** tabs.
  - For the ADM-10G card, click **Provisioning > Optics Thresholds** tabs.
  - For the 32MUX-O and 40MUX cards, click the **Provisioning > Optical Chn > Optics Thresholds** tabs.
  - For the 32WSS-O and 40WSS-C cards, click the **Provisioning > Optical Chn: Optical Connector x > Optics Thresholds** tabs.

**Tip**

To view the alarm thresholds (as opposed to the warning thresholds), check the **Alarm** check box on the bottom-left of the Optics Thresholds tab and click **Reset**.

- d. Compare the actual assigned Power value with the Alarm Threshold value and complete one of the following actions:
- If the Power value is less than the Fail Low threshold, go to [Step 3](#).
  - If the Power value is greater than the Fail Low threshold plus the alarm hysteresis (or allowance value) default of 1 dBm, complete the [“Reset a Card in CTC” procedure on page 2-241](#) for the card.

If the alarm does not clear, complete the [“Physically Replace a Card” procedure on page 2-244](#) and continue to [Step 9](#).

**Note**

When you replace a card with an identical type of card, you do not need to make any changes to the database other than restoring the card’s port to the IS,AINS or Unlocked,automaticInService administrative state.

- Step 3** Verify the fiber continuity to the port using site practices. Refer to the “Network Reference” chapter of the *Cisco ONS 15454 DWDM Reference Manual* for a procedure to detect a fiber cut.
- Step 4** Check the “Internal Connections” file generated by Cisco TransportPlanner for the node where the card is located. If necessary, recable the node in accordance with the MP file connections list. For procedures to cable a DWDM node, refer to the “Turn Up a Node” chapter of the *Cisco ONS 15454 DWDM Procedure Guide*.
- Step 5** If the cabling is good, verify that each involved optical signal source, including TXP, MXP or ITU-T line card trunk transmit ports, is in the IS (or Unlocked) administrative state. To do this, click the following tabs as appropriate:
- For the ADM-10G card, click the **Provisioning > Line > Ports** tabs.
  - For the TXP\_MR\_10G card, click the **Provisioning > Line > SONET** (or **Provisioning > Line > SDH**) tabs.
  - For the TXP\_MR\_10E card, click the **Provisioning > Line > SONET** (or **Provisioning > Line > SDH**) tabs.
  - For the TXP\_MR\_2.5G card, click the **Provisioning > Line > SONET** (or **Provisioning > Line > SDH**) tabs.
  - For the TXPP\_MR\_2.5G card, click the **Provisioning > Line > SONET** (or **Provisioning > Line > SDH**) tabs.

- For the MXP\_MR\_2.5G card, click the **Provisioning > Line > SONET** (or **Provisioning > Line > SDH**) tabs.
- For the MXPP\_MR\_2.5G card, click the **Provisioning > Line > SONET** (or **Provisioning > Line > SDH**) tabs.
- For the MXP\_2.5G\_10E card, click the **Provisioning > Line > Trunk** tabs.
- For the MXP\_2.5G\_10G card, click the **Provisioning > Line > SONET** (or **Provisioning > Line > SDH**) tabs.

If the port administrative state is not IS (or Unlocked), choose **IS** , or **Unlocked**, from the Admin state drop-down list. If the alarm does not clear, continue with [Step 9](#).

**Note**

If the LOS-P (OCH) alarm applies to a 32WSS-O passthrough port, it means that a single optical source is not directly connected to the port. In this case, follow the general troubleshooting rules given in “Network Level (Internode) Troubleshooting” to identify any other alarm upstream to the logical signal flow that could be the root cause for the outstanding alarm.

- Step 6** If the signal source is in IS (or Unlocked) administrative state, use an optical test set to verify that the transmit laser is active. For specific procedures to use the test set equipment, consult the manufacturer.
- Step 7** If the laser is active, compare the card’s provisioned transmit optical power value with the expected range in the “Provision Transponder and Muxponder Cards” chapter of the *Cisco ONS 15454 DWDM Procedure Guide*. To display the provisioned transmit optical power values, click the following tabs as appropriate:
- For the ADM-10G card, click **Performance > Optics PM > Current Values** tabs.
  - For the TXP\_MR\_10G card, click the **Performance > Optics PM > Current Values > Trunk Port** tabs.
  - For the TXP\_MR\_10E card, click the **Performance > Optics PM > Current Values > Trunk Port** tabs.
  - For the MXP\_2.5G\_10E card, click the **Performance > Optics PM > Current Values > Trunk Port** tabs.
  - For the MXP\_2.5G\_10G card, click the **Performance > Optics PM > Current Values > Trunk Port** tabs.
- Step 8** Use a standard power meter to measure actual transmit optical power for the following cards as applicable:
- GE-XP
  - 10GE-XP
  - ADM-10G
  - TXP\_MR\_2.5G
  - TXPP\_MR\_2.5G
  - MXP\_MR\_2.5G
  - MXPP\_MR\_2.5G
  - Every ITU-T line card



If the tested optical transmit optical power is within the expected range, go to [Step 9](#). If the actual power value is outside the specification range, complete the “[Physically Replace a Card](#)” procedure on [page 2-244](#). (These are listed in the “Hardware Specifications” appendix of the *Cisco ONS 15454 DWDM Reference Manual*.) When the newly installed card becomes active, verify that the LOS-P (OCH) alarm clears. If it does not, continue with [Step 9](#).

**Tip**

If a spare card is unavailable and the transmit power still functions, you can temporarily clear the LOS-P alarm by following the general procedure to add path VOAs during startup failure as noted in the “Perform Node Acceptance Tests” chapter of the *Cisco ONS 15454 DWDM Procedure Guide*. For more information about provisioning VOA setpoints, refer to the “Network Reference” chapter of the *Cisco ONS 15454 DWDM Reference Manual*.

**Step 9**

If the power is within the expected range, return to the port that reported LOS-P and clean the alarmed port’s fiber according to site practice. If no site practice exists, complete the procedure in the “Maintain the Node” chapter of the *Cisco ONS 15454 DWDM Procedure Guide*.

**Note**

Unplugging the fiber can cause a traffic hit. To avoid this, perform a traffic switch if possible. Refer to the “[2.8.2 Protection Switching, Lock Initiation, and Clearing](#)” section on [page 2-237](#) for basic instructions, or refer to the “Manage the Node” chapter in the *Cisco ONS 15454 DWDM Procedure Guide* for more detailed information.

**Step 10**

If the alarm does not clear, add path VOAs during startup failure as noted in the “Perform Node Acceptance Tests” chapter of the *Cisco ONS 15454 DWDM Procedure Guide* to remedy the problem.

**Step 11**

If the alarm does not clear, log into the Technical Support Website at <http://www.cisco.com/techsupport> for more information or call Cisco TAC (1-800-553-2447) in order to report a service-affecting problem.

## 2.5.170 LOS-P (TRUNK)

Default Severity: Critical (CR), Service-Affecting (SA)

Logical Object: TRUNK

The Loss of Signal Payload (LOS-P) alarm for the trunk layer indicates that the incoming payload signal is absent at the input trunk port. There still may be optical power on the fiber, but the payload data is missing. This alarm applies to the following cards: TXP\_MR\_10G, TXP\_MR\_10E, MXP\_2.5G\_10G, TXP\_MR\_2.5G, TXPP\_MR\_2.5G, MXP\_MR\_2.5G, MXPP\_MR\_2.5G, GE-XP, 10GE-XP, ADM-10G, OTU2\_XP and every ITU-T line card.

**Note**

The MXP\_2.5G\_10E has no LOS-P (TRUNK) option, because ITU-T G.709 encapsulation on the card cannot be disabled.

**Note**

With ITU-T G.709 encapsulation on, the alarm coming from the trunk is LOS-P (TRUNK) in accordance with the OTN standards.

**Note**

In R7.01, when an LOS-P (TRUNK) alarm occurs on TXP and MXP trunks, G709/SONET/SDH TCAs are suppressed. For details, see “Alarm and TCA Monitoring and Management” chapter in the *Cisco ONS 15454 DWDM Reference Manual*.

## Clear the LOS-P (TRUNK) Alarm

- Step 1** Verify that the card behaves correctly by checking the LED behavior on the physical card. A green ACT/SBY LED indicates an active card, and a red ACT/SBY LED indicates a failed card. If the LED is red, complete the “[Physically Replace a Card](#)” procedure on page 2-244 and continue to [Step 8](#).

**Note**

When you replace a card with an identical type of card, you do not need to make any changes to the database other than restoring the card’s port to the IS,AINS or Unlocked,automaticInService administrative state.

- Step 2** Verify that there truly is a loss of received optical power by completing the following steps:
- In node view (single-shelf mode) or shelf view (multishelf mode), double-click the alarmed card to open the card view.
  - Click the **Performance > Optics PM > Current Values > Trunk Port** tabs and view the RX Optical Pwr value.
  - Compare the actual power levels with the expected power range given in the “Hardware Specifications” appendix of the *Cisco ONS 15454 DWDM Reference Manual*. Complete one of the following actions:
    - If power is higher than –40 dBm (that is, –20 dBm, –1 dBm, 0 dBm or 10 dBm) and within the accepted range go to [Step 4](#).
    - or if the power is lower than –40 dBm (that is, –40 dBm, –45 dBm or –50 dBm) complete the “[Reset a Card in CTC](#)” procedure on page 2-241 for the card.
- Step 3** If the alarm does not clear, complete the “[Physically Replace a Card](#)” procedure on page 2-244 for the reporting card and then go to [Step 9](#).

**Note**

When you replace a card with an identical type of card, you do not need to make any changes to the database other than restoring the card’s port to the IS,AINS or Unlocked,automaticInService administrative state.

- Step 4** Verify the fiber continuity to the port by following site practices. Refer to the “Network Reference” chapter of the *Cisco ONS 15454 DWDM Reference Manual* for a procedure to detect a fiber cut.
- Step 5** Check the “Internal Connections” file generated by Cisco TransportPlanner for the node containing the alarmed card. If necessary, recable the node in accordance with the MP file connections list. For procedures to cable a DWDM node, refer to the “Turn Up a Node” chapter of the *Cisco ONS 15454 DWDM Procedure Guide*.
- Step 6** If the cabling is good, use a test set to verify the power value on the DWDM CH\_DROP-TX port on the AD-xC-xx.x, 32DMX-O, 32DMX, or 40DMX. For specific procedures to use the test set equipment, consult the manufacturer.

- Step 7** If the power difference reported is greater than 1 dBm (standard fiber jumper insertion loss is 0.3 dBm), clean the fiber according to site practice. If no site practice exists, complete the procedure in the “Maintain the Node” chapter of the *Cisco ONS 15454 DWDM Procedure Guide*.



**Note** Unplugging the fiber can cause a traffic hit. To avoid this, perform a traffic switch if possible. Refer to the “2.8.2 Protection Switching, Lock Initiation, and Clearing” section on page 2-237 for basic instructions, or to the “Manage the Node” chapter in the *Cisco ONS 15454 DWDM Procedure Guide* for more detailed information.

- Step 8** If the alarm does not clear, follow the general troubleshooting rules stated in the “Network Reference” chapter of the *Cisco ONS 15454 DWDM Reference Manual* to identify upstream alarms in the logical signal flow that could cause an LOS-P.
- Step 9** If the alarm does not clear, log into the Technical Support Website at <http://www.cisco.com/techsupport> for more information or call Cisco TAC (1-800-553-2447) in order to report a service-affecting problem.

## 2.5.171 LOS-RAMAN (OTS)

Default Severity: Critical (CR), Service-Affecting (SA)

SONET Logical Objects: OTS

The Loss of Raman signal alarm indicates that the Raman signal has not received by the RX RAMAN port on the OPT-RAMP-C card.

### Clear the LOS-RAMAN Condition

- Step 1** Verify that the fiber cable is properly connected and attached to the correct port. For more information about fiber connections and terminations, refer to the “Install Cards and Fiber-Optic Cables” chapter in the *Cisco ONS 15454 Procedure Guide*.



**Caution** Always use the supplied electrostatic discharge wristband when working with a powered ONS 15454. Plug the wristband cable into the ESD jack located lower-right edge of the shelf assembly.

- Step 2** Consult site records to determine whether the port raising the alarm has been assigned.
- Step 3** If the port is assigned, verify that the correct port is in service by completing the following steps:
- To confirm this physically, confirm that the card shows a green LED on the physical card.  
A green LED indicates an active card. An amber LED indicates a standby card.
  - To determine this virtually, double-click the card in CTC to display the card view and complete the following substeps:
    - Click the **Provisioning > Line** tabs.
    - Verify that the **Admin State** column lists the port as IS or Unlocked.
  - If the **Admin State** column lists the port as OOS,MT or Locked,maintenance or Locked,disabled, click the column and choose **IS or Unlocked**.



---

**Note** If a port in the OOS or Unlocked administrative state does not receive a signal, the LOS alarm is raised and the port service state transitions to Locked-disabled, automaticInService & failed.

---

d. Click **Apply**.

- Step 4** Use a test set to confirm that a valid signal exists on the line. Test the line as close to the receiving card as possible. For specific procedures to use the test set equipment, consult the manufacturer.
- Step 5** If a valid signal is not present and the transmitting device is operational, replace the cable connecting the transmitting device to the port. To do this, refer to the “Install Hardware” chapter in the *Cisco ONS 15454 Procedure Guide*.
- Step 6** Repeat Steps 1 to 5 for any other port on the card that reports the LOS-RAMAN condition.
- Step 7** If no other alarms are present that could be the source of the LOS-RAMAN condition, or if clearing an alarm did not clear the LOS-RAMAN condition, complete the “[Physically Replace a Card](#)” procedure on page 2-244 for the reporting card.



---

**Note** When you replace a card with the identical type of card, you do not need to make any changes to the database.

---

- Step 8** If the alarm does not clear, log into the Cisco Technical Support Website at <http://www.cisco.com/techsupport> for more information or log into <http://www.cisco.com/warp/public/687/Directory/DirTAC.shtml> to obtain a directory of toll-free Technical Support numbers for your country in order to report a Service-Affecting (SA) problem.
- 

## 2.5.172 LO-TXPOWER

Default Severity: Minor (MN), Non-Service-Affecting (NSA)

Logical Objects: 2R, EQPT, ESCON, FC, GE, ISC, OCN/STMN, PPM, TRUNK

The Equipment Low Transmit Power alarm is an indicator for the TXP\_MR\_10G, TXP\_MR\_2.5G, TXPP\_MR\_2.5G, TXP\_MR\_10E, TXP\_MR\_10E\_C, TXP\_MR\_10E\_L, MXP\_2.5G\_10G, OC192-XFP, ADM-10G, and OTU2\_XP card transmitted optical signal power. LO-TXPOWER occurs when the measured optical power of the transmitted signal falls under the threshold. The threshold value is user-provisionable.



---

**Note** For more information about MXP and TXP cards and their power levels, refer to the “Card Reference” in the *Cisco ONS 15454 DWDM Reference Manual*. For information about provisioning them, refer to the “Provision Transponder and Muxponder Cards” chapter in the *Cisco ONS 15454 DWDM Procedure Guide*.

---

## Clear the LO-TXPOWER Alarm

- 
- Step 1** In node view (single-shelf mode) or single-shelf view (multishelf mode), display the TXP\_MR\_10G, TXP\_MR\_2.5G, TXPP\_MR\_2.5G, TXP\_MR\_10E, TXP\_MR\_10E\_C, TXP\_MR\_10E\_L, MXP\_2.5G\_10G, OC192-XFP, ADM-10G, or OTU2\_XP card view.
- Step 2** Click the **Provisioning > Optics Thresholds > Current Values** tabs.
- Step 3** For the ADM-10G card, click the **Performance > Optics PM > Current Values** tabs.
- Step 4** Increase the TX Power Low column value by 0.5 dBm.
- Step 5** If the card transmit power setting cannot be increased without affecting the signal, complete the [“Physically Replace a Card” procedure on page 2-244](#).
- Step 6** If no ports are shown bad and the alarm does not clear, log into the Technical Support Website at <http://www.cisco.com/techsupport> for more information or call Cisco TAC (1-800-553-2447).
- 

## 2.5.173 LPBKCRS

Default Severity: Not Alarmed (NA), Non-Service-Affecting (NSA)

Logical Objects: STSMON, STSTRM

The Loopback Cross-Connect condition indicates that there is a software cross-connect loopback active between an optical card and an OC-192 card. A cross-connect loopback test occurs below line speed and does not affect traffic.



**Note**

Cross-connect loopbacks occur below line speed. They do not affect traffic.

---

## Clear the Condition

- 
- Step 1** To remove the loopback cross-connect condition, double-click the optical card in CTC to display the card view.
- Step 2** Complete the [“Clear an STM-N Card XC Loopback Circuit” procedure on page 2-246](#).
- Step 3** If the condition does not clear, log into the Technical Support Website at <http://www.cisco.com/techsupport> for more information or log into <http://www.cisco.com/warp/public/687/Directory/DirTAC.shtml> to obtain a directory of toll-free Technical Support numbers for your country.
- 

## 2.5.174 LPBKFACILITY (ESCON)

Default Severity: Not Alarmed (NA), Non-Service-Affecting (NSA)

Logical Object: ESCON

The LPBKFACILITY (ESCON) condition occurs on a TXP\_MR\_2.5G or TXPP\_MR\_2.5G card PPM (SFP) provisioned for FICON1G or FICON 2G line speed when there is a facility loopback active on the card.

For information about troubleshooting these circuits with loopbacks, refer to the “1.2 Troubleshooting MXP, TXP, XP, or ADM-10G Circuit Paths With Loopbacks” section on page 1-7.

## Clear the LPBKFACILITY (ESCON) Condition

- 
- Step 1** Complete the “Clear an MXP, TXP, GE-XP, 10GE-XP, and ADM-10G Card Loopback Circuit” procedure on page 2-245.
- Step 2** If the alarm does not clear, or if you need assistance conducting network troubleshooting tests, call Cisco TAC to report a Service-Affecting (SA) problem (1-800-553-2447).
- 

## 2.5.175 LPBKFACILITY (FC)

Default Severity: Not Alarmed (NA), Non-Service-Affecting (NSA)

Logical Object: FC

A Loopback Facility condition for the FC payload occurs on a fibre channel (FC) line when a software facility (line) loopback is active for an MXPP\_MR\_2.5G, MXP\_MR\_2.5G, TXPP\_MR\_2.5G, and TXP\_MR\_2.5G card client PPM (SFP) provisioned at the FC1G, FC2G, FICON1G, or FICON 2G line speed.

For information about troubleshooting these circuits with loopbacks, refer to the “1.2 Troubleshooting MXP, TXP, XP, or ADM-10G Circuit Paths With Loopbacks” section on page 1-7.



### Note

For more information about MXP and TXP cards, refer to the “Card Reference” chapter in the *Cisco ONS 15454 DWDM Reference Manual*. For information about provisioning them, refer to the “Provisioning Tranponder and Muxponder Cards” chapter in the *Cisco ONS 15454 DWDM Procedure Guide*.

---

## Clear the LPBKFACILITY (FC) Condition

- 
- Step 1** Complete the “Clear an MXP, TXP, GE-XP, 10GE-XP, and ADM-10G Card Loopback Circuit” procedure on page 2-245.
- Step 2** If the condition does not clear, log into the Technical Support Website at <http://www.cisco.com/techsupport> for more information or call Cisco TAC (1-800-553-2447).
- 

## 2.5.176 LPBKFACILITY (GE)

Default Severity: Not Alarmed (NA), Non-Service-Affecting (NSA)

Logical Object: GE

A Loopback Facility condition for a Gigabit Ethernet (GE) port occurs when a software facility (line) loopback is active for an MXP\_MR\_2.5G, MXPP\_MR\_2.5G, TXP\_MR\_2.5G, TXPP\_MR\_2.5G, GE-XP, 10GE-XP, and ADM-10G card client PPM (SFP) provisioned at the ONE\_GE port rate. For the TXP\_MR\_10E and TXP\_MR\_10G cards, this condition occurs when there is a facility loopback on a client PPM (SFP) provisioned at the TEN\_GE port rate.

For information about troubleshooting these circuits with loopbacks, refer to the “1.2 Troubleshooting MXP, TXP, XP, or ADM-10G Circuit Paths With Loopbacks” section on page 1-7.

**Note**

For more information about MXP and TXP cards, refer to the “Card Reference” chapter in the *Cisco ONS 15454 DWDM Reference Manual*. For information about provisioning them, refer to the “Provision Transponder and Muxponder Cards” chapter in the *Cisco ONS 15454 DWDM Procedure Guide*.

## Clear the LPBKFACILITY (GE) Condition

- 
- Step 1** Complete the “[Clear an MXP, TXP, GE-XP, 10GE-XP, and ADM-10G Card Loopback Circuit](#)” procedure on page 2-245.
- Step 2** If the condition does not clear, log into the Technical Support Website at <http://www.cisco.com/techsupport> for more information or call Cisco TAC (1-800-553-2447).
- 

## 2.5.177 LPBKFACILITY (ISC)

Default Severity: Not Alarmed (NA), Non-Service-Affecting (NSA)

Logical Object: ISC

A Loopback Facility condition for an ISC port occurs when a software facility (line) loopback is active for a TXPP\_MR\_2.5G or TXP\_MR\_2.5G client PPM (SFP) provisioned at the ISC port rate.

For information about troubleshooting these circuits with loopbacks, refer to the “1.2 Troubleshooting MXP, TXP, XP, or ADM-10G Circuit Paths With Loopbacks” section on page 1-7.

**Note**

For more information about MXP and TXP cards, refer to the “Card Reference” chapter in the *Cisco ONS 15454 DWDM Reference Manual*. For information about provisioning them, refer to the “Provision Transponder and Muxponder Cards” chapter in the *Cisco ONS 15454 DWDM Procedure Guide*.

## Clear the LPBKFACILITY (ISC) Condition

- 
- Step 1** Complete the “[Clear an MXP, TXP, GE-XP, 10GE-XP, and ADM-10G Card Loopback Circuit](#)” procedure on page 2-245.
- Step 2** If the condition does not clear, log into the Technical Support Website at <http://www.cisco.com/techsupport> for more information or call Cisco TAC (1-800-553-2447).
-

## 2.5.178 LPBKFACILITY (TRUNK)

Default Severity: Not Alarmed (NA), Non-Service Affecting (NSA)

Logical Object: TRUNK

A Loopback Facility condition on MXP, TXP, GE-XP, 10GE-XP, and ADM-10G card trunk ports indicates that there is an active facility (line) loopback on the port. For this condition to be present, the administrative state is OOS,MT (or Locked,maintenance).

For information about troubleshooting these circuits with loopbacks, refer to the “1.2 Troubleshooting MXP, TXP, XP, or ADM-10G Circuit Paths With Loopbacks” section on page 1-7.



**Caution**

---

CTC permits loopbacks on an in-service (IS or Unlocked) circuit. Loopbacks are service-affecting.

---

### Clear the LPBKFACILITY (TRUNK) Condition

- 
- Step 1** Complete the “[Clear an MXP, TXP, GE-XP, 10GE-XP, and ADM-10G Card Loopback Circuit](#)” procedure on page 2-245.
- Step 2** If the condition does not clear, log into the Technical Support Website at <http://www.cisco.com/techsupport> for more information or call Cisco TAC (1-800-553-2447).
- 

## 2.5.179 LPBKTERMINAL (ESCON)

Default Severity: Not Alarmed (NA), Non-Service-Affecting (NSA)

Logical Object: ESCON

The LPBKTERMINAL (ESCON) condition occurs on a TXP\_MR\_2.5G or TXPP\_MR\_2.5G card PPM (SFP) provisioned for FICON1G or FICON 2G line speed when there is a terminal loopback active on the card.

For information about troubleshooting these circuits with loopbacks, refer to the “1.2 Troubleshooting MXP, TXP, XP, or ADM-10G Circuit Paths With Loopbacks” section on page 1-7.

### Clear the LPBKTERMINAL (ESCON) Condition

- 
- Step 1** Complete the “[Clear an MXP, TXP, GE-XP, 10GE-XP, and ADM-10G Card Loopback Circuit](#)” procedure on page 2-245.
- Step 2** If the alarm does not clear, or if you need assistance conducting network troubleshooting tests, call Cisco TAC to report a Service-Affecting (SA) problem (1-800-553-2447).
- 

## 2.5.180 LPBKTERMINAL (FC)

Default Severity: Not Alarmed (NA), Non-Service-Affecting (NSA)



Logical Object: FC

A Loopback Terminal condition for the FC payload occurs on an FC when a software terminal (inward) loopback is active for an MXP\_MR\_2.5G, MXPP\_MR\_2.5G, TXP\_MR\_2.5G, TXPP\_MR\_2.5G, GE-XP, and 10GE-XP card client PPM (SFP) provisioned at the FC1G, FC2G, FICON1G, or FICON2G line speed.

For information about troubleshooting these circuits with loopbacks, refer to the “1.2 Troubleshooting MXP, TXP, XP, or ADM-10G Circuit Paths With Loopbacks” section on page 1-7.

**Note**

For more information about MXP and TXP cards, refer to the “Card Reference” chapter in the *Cisco ONS 15454 DWDM Reference Manual*. For information about provisioning them, refer to the “Provisioning Transponder and Muxponder Cards” chapter in the *Cisco ONS 15454 DWDM Procedure Guide*.

## Clear the LPBKTERMINAL (FC) Condition

- 
- Step 1** Complete the “[Clear an MXP, TXP, GE-XP, 10GE-XP, and ADM-10G Card Loopback Circuit](#)” procedure on page 2-245.
- Step 2** If the condition does not clear, log into the Technical Support Website at <http://www.cisco.com/techsupport> for more information or call Cisco TAC (1-800-553-2447).
- 

## 2.5.181 LPBKTERMINAL (GE)

Default Severity: Not Alarmed (NA), Non-Service-Affecting (NSA)

Logical Object: GE

A Loopback Terminal condition for a GE port occurs when a software terminal (inward) loopback is active for an MXP\_MR\_2.5G, MXPP\_MR\_2.5G, TXP\_MR\_2.5G, and TXPP\_MR\_2.5G card client PPM (SFP) provisioned at the ONE\_GE port rate. For the TXP\_MR\_10E and TXP\_MR\_10G cards, this condition occurs when there is a facility loopback on a client PPM (SFP) provisioned at the TEN\_GE port rate.

For information about troubleshooting these circuits with loopbacks, refer to the “1.2 Troubleshooting MXP, TXP, XP, or ADM-10G Circuit Paths With Loopbacks” section on page 1-7.

**Note**

For more information about MXP and TXP cards, refer to the “Card Reference” chapter in the *Cisco ONS 15454 DWDM Reference Manual*. For information about provisioning them, refer to the “Provision Transponder and Muxponder Cards” chapter in the *Cisco ONS 15454 DWDM Procedure Guide*.

## Clear the LPBKTERMINAL (GE) Condition

- 
- Step 1** Complete the “[Clear an MXP, TXP, GE-XP, 10GE-XP, and ADM-10G Card Loopback Circuit](#)” procedure on page 2-245.
-

- Step 2** If the condition does not clear, log into the Technical Support Website at <http://www.cisco.com/techsupport> for more information or call Cisco TAC (1-800-553-2447).
- 

## 2.5.182 LPBKTERMINAL (ISC)

Default Severity: Not Alarmed (NA), Non-Service-Affecting (NSA)

Logical Object: ISC

A Loopback Terminal condition for an ISC port occurs when a software terminal (inward) loopback is active for a TXPP\_MR\_2.5G or TXP\_MR\_2.5G client PPM (SFP) provisioned at the ISC port rate.

For information about troubleshooting these circuits with loopbacks, refer to the “1.2 Troubleshooting MXP, TXP, XP, or ADM-10G Circuit Paths With Loopbacks” section on page 1-7.



**Note**

For more information about MXP and TXP cards, refer to the “Card Reference” chapter in the *Cisco ONS 15454 DWDM Reference Manual* and “Provisioning Transponder and Muxponder Cards” chapter in the *Cisco ONS 15454 DWDM Procedure Guide*.

---

### Clear the LPBKTERMINAL (ISC) Condition

- Step 1** Complete the “[Clear an MXP, TXP, GE-XP, 10GE-XP, and ADM-10G Card Loopback Circuit](#)” procedure on page 2-245.
- Step 2** If the condition does not clear, log into the Technical Support Website at <http://www.cisco.com/techsupport> for more information or call Cisco TAC (1-800-553-2447).
- 

## 2.5.183 LPBKTERMINAL (TRUNK)

Default Severity: Not Alarmed (NA), Non-Service Affecting (NSA)

Logical Object: TRUNK

A Loopback Terminal condition on MXP or TXP trunk card indicates that there is an active terminal (inward) loopback on the port.

For information about troubleshooting, refer to the “1.2 Troubleshooting MXP, TXP, XP, or ADM-10G Circuit Paths With Loopbacks” section on page 1-7.

### Clear the LPBKTERMINAL (TRUNK) Condition

- Step 1** Complete the “[Clear an MXP, TXP, GE-XP, 10GE-XP, and ADM-10G Card Loopback Circuit](#)” procedure on page 2-245.
- Step 2** If the condition does not clear, log into the Technical Support Website at <http://www.cisco.com/techsupport> for more information or call Cisco TAC (1-800-553-2447).
-

## 2.5.184 LWBATVG

Default Severity: Major (MJ), Service-Affecting (SA)

Logical Object: PWR

The Low Voltage Battery alarm occurs in a –48 VDC environment when a battery lead input voltage falls below the low power threshold. This threshold, with a default value of –44 VDC, is user-provisionable. The alarm remains raised until the voltage remains above the threshold for 120 seconds. (For information about changing this threshold, refer to the “Turn Up Node” chapter in the *Cisco ONS 15454 DWDM Procedure Guide*.)

### Clear the LWBATVG Alarm

- 
- Step 1** The problem is external to the ONS system. Troubleshoot the power source supplying the battery leads.
- Step 2** If the alarm does not clear, log into the Technical Support Website at <http://www.cisco.com/techsupport> for more information or call Cisco TAC (1-800-553-2447) in order to report a Service-Affecting (SA) problem.
- 

## 2.5.185 MAN-REQ

Default Severity: Not Alarmed (NA), Non-Service-Affecting (NSA)

Logical Object: EQPT

The Manual Switch Request condition occurs when a user initiates a Manual switch request on an OC-N/STM-N port. Clearing the Manual switch clears the MAN-REQ condition. You do not need to clear the switch if you want the Manual switch to remain.

### Clear the MAN-REQ Condition

- 
- Step 1** Complete the “[Initiate a 1+1 Manual Switch Command](#)” procedure on page 2-237.
- Step 2** If the condition does not clear, log into the Technical Support Website at <http://www.cisco.com/techsupport> for more information or call Cisco TAC (1-800-553-2447).
- 

## 2.5.186 MANRESET

Default Severity: Not Alarmed (NA), Non-Service-Affecting (NSA)

Logical Object: EQPT

A User-Initiated Manual Reset condition occurs when you right-click a card in CTC and choose Reset.

**Note**

MANRESET is an informational condition and does not require troubleshooting.

---

## 2.5.187 MANSWTOINT

Default Severity: Not Alarmed (NA), Non-Service-Affecting (NSA)

Logical Object: NE-SREF

The Manual Switch To Internal Clock condition occurs when the NE timing source is manually switched to an internal timing source.



**Note**

---

MANSWTOINT is an informational condition and does not require troubleshooting.

---

## 2.5.188 MANSWTOPRI

Default Severity: Not Alarmed (NA), Non-Service-Affecting (NSA)

Logical Objects: EXT-SREF, NE-SREF

The Manual Switch To Primary Reference condition occurs when the NE timing source is manually switched to the primary timing source.



**Note**

---

MANSWTOPRI is an informational condition and does not require troubleshooting.

---

## 2.5.189 MANSWTOSEC

Default Severity: Not Alarmed (NA), Non-Service-Affecting (NSA)

Logical Objects: EXT-SREF, NE-SREF

The Manual Switch To Second Reference condition occurs when the NE timing source is manually switched to a second timing source.



**Note**

---

MANSWTOSEC is an informational condition and does not require troubleshooting.

---

## 2.5.190 MANSWTOTHIRD

Default Severity: Not Alarmed (NA), Non-Service-Affecting (NSA)

Logical Objects: EXT-SREF, NE-SREF

The Manual Switch To Third Reference condition occurs when the NE timing source is manually switched to a third timing source.



**Note**

---

MANSWTOTHIRD is an informational condition and does not require troubleshooting.

---

## 2.5.191 MANUAL-REQ-SPAN (2R, ESCON, FC, GE, ISC, OCN/STMN, OTS)

Default Severity: Not Alarmed (NA), Non-Service-Affecting (NSA)

Logical Objects: 2R, ESCON, FC, GE, ISC, OCN/STMN, OTS

The Manual Switch Request on Ring condition for clients occurs when a user initiates a Manual Span command on an MXP or TXP client for the above-listed client types to move traffic from a working span to a protect span. This condition appears on the network view Alarms, Conditions, and History tabs. The port where the MANUAL SPAN command was applied is marked with an “M” on the network view detailed circuit map.

**Note**

For more information about protection schemes, refer to the “Network Reference” chapter of the *Cisco ONS 15454 DWDM Reference Manual*.

## 2.5.192 MANUAL-REQ-SPAN (TRUNK)

Default Severity: Not Alarmed (NA), Non-Service-Affecting (NSA)

Logical Object: TRUNK

The Manual Switch Request on Ring condition for the trunk occurs when a user initiates a Manual Span command on an MXP or TXP trunk port in a splitter protection group to move traffic from a working span to a protect span. This condition appears on the network view Alarms, Conditions, and History tabs. The port where the MANUAL SPAN command was applied is marked with an “M” on the network view detailed circuit map.

**Note**

For more information about protection schemes, refer to the “Network Reference” chapter of the *Cisco ONS 15454 DWDM Reference Manual*.

## 2.5.193 MEA (AIP)

Default Severity: Critical (CR), Service-Affecting (SA)

Logical Object: AIP

If the Mismatch of Equipment Attributes (MEA) alarm is reported against the AIP, the fuse in the AIP board blew or is missing. The MEA alarm also occurs when an old AIP board with a 2-A fuse is installed in a newer ANSI 10-Gbps-compatible shelf assembly (15454-SA-ANSI or 15454-SA-HD).

### Clear the MEA (AIP) Alarm

- 
- Step 1** Complete the “[Replace the Alarm Interface Panel](#)” procedure on page 2-250.
- Step 2** If the alarm does not clear, log into the Technical Support Website at <http://www.cisco.com/techsupport> for more information or call Cisco TAC (1-800-553-2447) in order to report a Service-Affecting (SA) problem.
- 

## 2.5.194 MEA (EQPT)

Default Severity: Critical (CR), Service-Affecting (SA)

Logical Object: EQPT

The MEA alarm for equipment is reported against a card slot when the physical card inserted into a slot does not match the card type that is provisioned for that slot in CTC. Removing the incompatible cards clears the alarm. For more information about card compatibility, refer to the “Card Reference” chapter of the *Cisco ONS 15454 DWDM Reference Manual*.



**Note**

For more information about protection schemes, refer to the “Network Reference” chapter of the *Cisco ONS 15454 DWDM Reference Manual*.

## Clear the MEA (EQPT) Alarm

- Step 1** Physically verify the type of card that is installed in the slot reporting the MEA alarm. In node view (single-shelf mode) or shelf view (multishelf mode), click the **Inventory** tab and compare it to the actual installed card.
- Step 2** Determine whether the ONS system shelf assembly is a newer 10-Gbps-compatible shelf assembly (15454-SA-ANSI or 15454-SA-HD) or an earlier shelf assembly. Under the HW Part # column, if the part number is 800-19857-XX or 800-19856-XX, then you have a 15454-SA-ANSI shelf. If the part number is 800-24848-XX, then you have a 15454-SA-HD shelf. If the number is not one of those listed here, then you are using an earlier shelf assembly.



**Note**

On the 15454-SA-HD (P/N: 800-24848), 15454-SA-NEBS3E, 15454-SA-NEBS3, and 15454-SA-R1 (P/N: 800-07149) shelves, the AIP cover is clear plastic. On the 15454-SA-ANSI shelf (P/N: 800-19857), the AIP cover is metal.

- Step 3** If you prefer the card type depicted by CTC, complete the [“Physically Replace a Card” procedure on page 2-244](#) for the reporting card.
- Step 4** If you prefer the card that physically occupies the slot but the card is not in service, does not have circuits mapped to it, and is not part of a protection group, place the cursor over the provisioned card in CTC and right-click to choose **Delete Card**.

The card that physically occupies the slot reboots, and CTC automatically provisions the card type into that slot.



**Note**

If the card is in service, does have circuits mapped to it, is paired in a working protection scheme, has DCC communications turned on, or is used as a timing reference, CTC does not allow you to delete the card.

- Step 5** If any ports on the card are in service, place them out of service (OOS,MT or Locked,maintenance):



**Caution**

Before placing ports out of service, ensure that live traffic is not present.

- a. In node view (single-shelf mode) or shelf view (multishelf mode), double-click the reporting card to open the card view.
- b. Click the **Provisioning** tab.
- c. Click the administrative state of any in-service ports.

d. Choose **OOS,MT** (or **Locked,maintenance**) to take the ports out of service.

**Step 6** If a circuit has been mapped to the card, complete the [“Delete a Circuit” procedure on page 2-245](#).



**Caution** Before deleting the circuit, ensure that live traffic is not present.

**Step 7** If the card is paired in a protection scheme, delete the protection group:

- node view (single-shelf mode) or shelf view (multishelf mode), click the **Provisioning > Protection** tabs.
- Choose the protection group of the reporting card.
- Click **Delete**.

**Step 8** Right-click the card reporting the alarm.

**Step 9** Choose **Delete**.

The card that physically occupies the slot reboots, and CTC automatically provisions the card type into that slot.

**Step 10** If the alarm does not clear, log into the Technical Support Website at <http://www.cisco.com/techsupport> for more information or call Cisco TAC (1-800-553-2447) in order to report a Service-Affecting (SA) problem.

## 2.5.195 MEA (FAN)

Default Severity: Critical (CR), Service-Affecting (SA)

Logical Object: FAN

The MEA alarm is reported against the fan-tray assembly when a newer fan-tray assembly (15454-FTA3) with a 5-A fuse is used with an older shelf assembly or when an older fan-tray assembly with a 2-A fuse is used with a newer 10-Gbps-compatible shelf assembly (15454-SA-ANSI or 15454-SA-HD) that contains cards introduced in Release 3.1 or later. If a 10-Gbps-compatible shelf assembly contains only cards introduced before Release 3.1, then an older fan-tray assembly (15454-FTA-2) can be used and does not report an MEA alarm.

### Clear the MEA (FAN) Alarm

**Step 1** Determine whether the shelf assembly is a newer 10-Gbps-compatible shelf assembly (15454-SA-ANSI or 15454-SA-HD) or an earlier shelf assembly. In node view (single-shelf mode) or shelf view (multishelf mode), click the **Inventory** tab.

Under the HW Part # column, if the part number is 800-19857-XX or 800-19856-XX, then you have a 15454-SA-ANSI shelf. If the part number is 800-24848-XX, you have a 15454-SA-HD shelf.

Under the HW Part # column, if the number is not one of those listed here, then you are using an earlier shelf assembly.

**Step 2** If you have a 10-Gbps-compatible shelf assembly (15454-SA-ANSI or 15454-SA-HD), the alarm indicates that an older incompatible fan-tray assembly is installed in the shelf assembly. Obtain a newer fan-tray assembly (15454-FTA3) with a 5-A fuse and complete the [“Replace the Fan-Tray Assembly” procedure on page 2-249](#).

- Step 3** If you are using an earlier shelf assembly, the alarm indicates that you are using a newer fan-tray assembly (15454-FTA3), which is incompatible with the earlier version of the shelf assembly. Obtain an earlier version of the fan-tray assembly (15454-FTA2) and complete the [“Replace the Fan-Tray Assembly” procedure on page 2-249](#).
- Step 4** If the alarm does not clear, log into the Technical Support Website at <http://www.cisco.com/techsupport> for more information or call Cisco TAC (1-800-553-2447) in order to report a Service-Affecting (SA) problem.

## 2.5.196 MEA (PPM)

Default Severity: Critical (CR), Service-Affecting (SA)

Logical Object: PPM

The Missing Equipment Attributes alarm for the PPM (SFP) is raised on TXP, MXP, MRC-12 and OC192-XFP/STM-64-XP cards when the PPM (SFP) is misprovisioned or unsupported. It can occur when you provision the PPM (SFP) for a wavelength that is explicitly not the first tunable wavelength.



**Note** For general information about DWDM cards, refer to the “Card Reference” chapter in the *Cisco ONS 15454 DWDM Reference Manual*. For PPM (SFP) specifications, refer to the “Hardware Specifications” appendix in the same manual. For information about MRC-12 cards, refer to the “Optical Cards” chapter in the *Cisco ONS 15454 Reference Manual*.

### Clear the MEA (PPM) Alarm

- Step 1** To provision the PPM (SFP), you must first create it in CTC. To do this, complete the following steps:
- In node view (single-shelf mode) or shelf view (multishelf mode), double-click the reporting card to open the card view.
  - Click the **Provisioning > Pluggable Port Modules** tabs. (If you already see the PPM [SFP] listed in the Pluggable Port Modules Area, go to [Step 2](#).)
  - Under the Pluggable Port Modules area, click **Create**.
  - In the Create PPM dialog box, choose the card PPM (SFP) number from the drop-down list (for example, PPM 1).
  - Choose the PPM (SFP) type from the second drop-down list, for example PPM (1 Port).
  - Click **OK**.



**Note** For more information about provisioning MXP or TXP PPMs (SFPs), refer to the “Turn Up a Node” chapter in the *Cisco ONS 15454 DWDM Procedure Guide*. For information to provision PPMs (SFPs) for the MRC-12 and OC192/STM64-XFP, refer to the “Optical Cards” chapter in the *Cisco ONS 15454 Reference Manual*.

- Step 2** After you have created the PPM (SFP), or if you see it listed in the Pluggable Port Modules area but not in the Selected PPM area, choose the port rate:
- Under the Selected PPM area, click **Create**.



- b. In the Create Port dialog box, choose the port (for example, 1-1) from the drop-down list.
  - c. Choose the correct port type from the drop-down list. (For more information about selecting PPM (SFP) port types, refer to the “Provision Transponder and Muxponder Cards” chapter of the *Cisco ONS 15454 DWDM Procedure Guide*.)
  - d. Click **OK**.
- Step 3** If you see the port listed in the Pluggable Port Modules area and the Selected PPM area, the MEA indicates that the incorrect port rate was selected. Click the port in the Selected PPM area and click **Delete**.
- Step 4** Complete [Step 2](#) to correctly provision the port rate.
- Step 5** If the alarm does not clear, log into the Technical Support Website at <http://www.cisco.com/techsupport> for more information or call Cisco TAC (1-800-553-2447) in order to report a Service-Affecting (SA) problem.

## 2.5.197 MEA (SHELF)

Default Severity: Critical (CR), Service-Affecting (SA)

Logical Object: SHELF

The MEA (Shelf) condition is raised when ANSI and ETSI shelves exist in the same node. For example, an ANSI subtended shelf is configured on an ETSI node controller or an ETSI subtended shelf is configured on an ANSI node controller.

### Clear the MEA (SHELF) Condition

Step 1 Ensure that the shelves in the node are either ANSI only or ETSI only.

Step 2 If the condition does not clear, log onto <http://www.cisco.com/tac> for more information or call TAC (1-800-553-2447).

## 2.5.198 MEM-GONE

Default Severity: Major (MJ), Non-Service-Affecting (NSA)

Logical Object: EQPT

The Memory Gone alarm occurs when data generated by software operations exceeds the memory capacity of the TCC2/TCC2P card. The TCC2/TCC2P cards which exceed the memory capacity reboot to avoid failure of card operations.



**Note**

The alarm does not require user intervention. The MEM-LOW alarm always precedes the MEM-GONE alarm.

## 2.5.199 MEM-LOW

Default Severity: Minor (MN), Non-Service-Affecting (NSA)

Logical Object: EQPT

The Free Memory of Card Almost Gone alarm occurs when data generated by software operations is close to exceeding the memory capacity of the TCC2/TCC2P card. The alarm clears when additional memory becomes available. If additional memory is not made available and the memory capacity of the card is exceeded, CTC ceases to function.

The alarm does not require user intervention. If the alarm does not clear, log into the Technical Support Website at <http://www.cisco.com/techsupport> for more information or call Cisco TAC (1-800-553-2447).

## 2.5.200 MFGMEM

Default Severity: Critical (CR), Service-Affecting (SA)

Logical Objects: AICI-AEP, AICI-AIE, AIP, BPLANE, FAN, PPM

The Manufacturing Data Memory Failure alarm occurs when the EEPROM fails on a card or component, or when the TCC2/TCC2P card cannot read this memory. EEPROM stores manufacturing data that a system TCC2/TCC2P card uses to determine system compatibility and shelf inventory status. Unavailability of this information can cause less-significant problems. The AIP EEPROM also stores the system MAC address. If the MFGMEM alarm indicates EEPROM failure on these panels, IP connectivity could be disrupted and the system icon is grayed out in CTC network view.



**Tip**

When you lose LAN connectivity with an ONS system due to an MFGMEM alarm on the AIP, you can reestablish node management by disconnecting the Ethernet cable from the panel and connecting it to the active TCC2/TCC2P card LAN port.

### Clear the MFGMEM Alarm

- 
- Step 1** Complete the [“Reset an Active TCC2/TCC2P Card and Activate the Standby Card” procedure on page 2-241](#).  
Wait ten minutes to verify that the card you reset completely reboots and becomes the standby card.
  - Step 2** If the reset card has not rebooted successfully, or the alarm has not cleared, call Cisco TAC (1-800-553-2447). If the Cisco TAC technician tells you to reseat the card, complete the [“Remove and Reinsert \(Reseat\) the Standby TCC2/TCC2P Card” procedure on page 2-242](#). If the Cisco TAC technician tells you to remove the card and reinstall a new one, complete the [“Physically Replace a Card” procedure on page 2-244](#).
  - Step 3** If the MFGMEM alarm continues to report after replacing the TCC2/TCC2P cards, the problem lies with the EEPROM.
  - Step 4** If the MFGMEM is reported from the fan-tray assembly, obtain a fan-tray assembly and complete the [“Replace the Fan-Tray Assembly” procedure on page 2-249](#).
  - Step 5** If the MFGMEM is reported from the AIP, the backplane, or the alarm persists after the fan-tray assembly is replaced, log into the Technical Support Website at <http://www.cisco.com/techsupport> for more information or call Cisco TAC (1-800-553-2447) to report a Service-Affecting (SA) problem.
-

## 2.5.201 MS-AIS

Default Severity: Not Reported (NR), Non-Service-Affecting (NSA)

Logical Object: STM1E, STMN

The Multiplex Section (MS) AIS condition indicates that there is a defect in the multiplexing section layer of the SONET overhead. The multiplex section refers to the segment between two SONET devices in the circuit and is also known as a maintenance span. The multiplex section layer of the SONET overhead deals with payload transport, and its functions include multiplexing and synchronization.

Generally, any AIS is a special SONET signal that communicates to the receiving node when the transmit node does not send a valid signal. AIS is not considered an error. It is raised by the receiving node on each input when it detects the AIS instead of a real signal. In most cases when this condition is raised, an upstream node is raising an alarm to indicate a signal failure; all nodes downstream from it only raise some type of AIS. This condition clears when you resolved the problem on the upstream node.

### Clear the MS-AIS Condition

- 
- Step 1** Complete the “[Clear the AIS Condition](#)” procedure on page 2-27.
- Step 2** If the condition does not clear, log into the Cisco Technical Support Website at <http://www.cisco.com/techsupport> for more information or log into <http://www.cisco.com/warp/public/687/Directory/DirTAC.shtml> to obtain a directory of toll-free Technical Support numbers for your country.
- 

## 2.5.202 MS-DEG

Default Severity: Not Alarmed (NA), Non-Service-Affecting (NSA)

Logical Object: STM1E

The Multiplex Section Signal Degrade condition is similar to the “[SDBER-EXCEED-HO](#)” alarm on page 2-203, but applies only to the multiplex section overhead of the EQPT object.

### Clear the MS-DEG Condition

- 
- Step 1** Complete the “[Clear the SDBER-EXCEED-HO Condition](#)” procedure on page 2-203.
- Step 2** If the condition does not clear, log into the Cisco Technical Support Website at <http://www.cisco.com/techsupport> for more information or log into <http://www.cisco.com/warp/public/687/Directory/DirTAC.shtml> to obtain a directory of toll-free Technical Support numbers for your country.
- 

## 2.5.203 MS-EOC

Default Severity: Minor (MN), Non-Service-Affecting (NSA)

Logical Object: STMN

The MS-DCC Termination Failure alarm occurs when the ONS 15454 loses its data communications channel. The DCC is nine bytes, D4 through D 12, in the SONET overhead. The bytes convey information about Operation, Administration, Maintenance, and Provisioning (OAM&P). The ONS 15454 uses the DCC on the SONET section overhead to communicate network management information.

## Clear the MS-EOC Alarm

---

- Step 1** Complete the [“Clear the RS-EOC Alarm” procedure on page 2-199](#).
- Step 2** If the condition does not clear, log into the Cisco Technical Support Website at <http://www.cisco.com/techsupport> for more information or log into <http://www.cisco.com/warp/public/687/Directory/DirTAC.shtml> to obtain a directory of toll-free Technical Support numbers for your country.
- 

## 2.5.204 MS-EXC

Default Severity: Not Alarmed (NA), Non-Service-Affecting (NSA)

Logical Object: STM1E

The Multiplex Section Signal Excessive BER condition is similar to the [“SDBER-EXCEED-HO” alarm on page 2-203](#), but applies only to the multiplex section overhead of the EQPT object.

## Clear the MS-EXC Condition

---

- Step 1** Complete the [“Clear the SDBER-EXCEED-HO Condition” procedure on page 2-203](#).
- Step 2** If the condition does not clear, log into the Cisco Technical Support Website at <http://www.cisco.com/techsupport> for more information or log into <http://www.cisco.com/warp/public/687/Directory/DirTAC.shtml> to obtain a directory of toll-free Technical Support numbers for your country.
- 

## 2.5.205 MS-RFI

Default Severity: Not Reported (NR), Non-Service-Affecting (NSA)

Logical Object: STM1E, STMN

The MS Remote Fault Indication (RFI) condition indicates that there is an RFI occurring at the SONET overhead multiplexing section level.

An RFI occurs when the ONS 15454 detects an RFI in the SONET overhead because of a fault in another node. Resolving the fault in the adjoining node clears the MS-RFI condition in the reporting node.

## Clear the MS-RFI Condition

- 
- Step 1** Log into the far-end node of the reporting ONS 15454.
  - Step 2** Determine whether there are other alarms, especially the LOS(STM1E, STMN).
  - Step 3** Clear the main alarm. See the appropriate alarm section in this chapter for the procedure.
  - Step 4** If the condition does not clear, log into the Cisco Technical Support Website at <http://www.cisco.com/techsupport> for more information or log into <http://www.cisco.com/warp/public/687/Directory/DirTAC.shtml> to obtain a directory of toll-free Technical Support numbers for your country.
- 

## 2.5.206 MT-OCHNC

Default Severity: Not Alarmed (NA), Non-Service-Affecting (NSA)

Logical Object: OTS

The MT-OCHNC condition occurs when the user provisions (tunes) a specific wavelength for maintenance on a WXC card from an input port (EXP1-8, ADD-RX) to the output port (COM-TX).

### Clear the MT-OCHNC Condition

- 
- Step 1** Delete the provisioned wavelength that was specifically tuned for maintenance purposes on a WXC card.
  - Step 2** If the condition does not clear, log into the Technical Support Website at <http://www.cisco.com/techsupport> for more information or call Cisco TAC (1 800 553-2447).
- 

## 2.5.207 NON-CISCO-PPM

Default Severity: Minor (MN), Non-Service-Affecting (NSA)

Logical Object: PPM

The Non-Cisco PPM Inserted condition occurs when a PPM that is plugged into a card's port fails the security code check. The check fails when the PPM used is not a Cisco PPM.

### Clear the NON-CISCO-PPM Condition

- 
- Step 1** Obtain the correct Cisco PPM and replace the existing PPM with the new one.
  - Step 2** If the condition does not clear, log into the Technical Support Website at <http://www.cisco.com/techsupport> for more information or call Cisco TAC (1-800-553-2447).
-

## 2.5.208 NOT-AUTHENTICATED

Default Severity: Minor (MN), Non-Service-Affecting (NSA)

Logical Object: SYSTEM

The NOT-AUTHENTICATED alarm is raised by CTC (not by the NE) when CTC fails to log into a node. This alarm only appears in CTC where the login failure occurred. This alarm differs from the “INTRUSION-PSWD” alarm, page 2-113, because INTRUSION-PSWD occurs when a user exceeds the login failures threshold.



### Note

NOT-AUTHENTICATED is an informational alarm and is resolved when CTC successfully logs into the node.

## 2.5.209 OCHNC-INC

Default Severity: Not Alarmed (NA), Non-Service-Affecting (NSA)

Logical Object: OCHNC-CONN

The Optical Channel (OCH) Incomplete Cross-Connection condition is raised when an OCH cross connection on a two-way circuit is deleted. For example, if you create an OCH circuit on a linear DWDM structure with Nodes A, B and C—originating at Node A, traversing through Node B, and terminating at Node C—then mistakenly delete a cross-connect (such as by TL1 command DLT-WLEN) on Nodes B or C, this condition is raised on the source node (A). The condition is corrected by regenerating the cross-connect. The alarm also follows these guidelines:

- Two-way circuit with Nodes A, B, and C (as described in the preceding example): Deleting a cross-connection on Nodes B or C will raise OCHNC-INC on the Node A cross connection.
- Two-way circuit with Nodes A, B, and C: Deleting a cross connection on Node A will raise an OCHNC-INC alarm on the Node C cross connection.
- One-way circuit with Nodes A, B and C: Deleting a cross connection on Nodes B or C will raise an OCHNC-INC alarm on Node A cross connection.
- One-way circuit with Nodes A, B, and C: Deleting a cross connection on Node A will not raise an OCHNC-INC alarm.



### Note

If you delete one of the cross-connects, you might not be able to recreate this same circuit with CTC because the wavelength is already being used on the other component nodes for add, drop, or express.

The OCHNC-INC alarm can also be raised if you restore one node’s database that is inconsistent with other node databases, following the guidelines previously listed. (That is, an inconsistent database that does not contain up-to-date circuit cross-connection information will cause the same problem as if you had deleted the cross-connect.)



### Caution

It is important to create a backup version of the database for each node of a topology during a known-stable situation. You should give the saved files names that indicate their version and date or any other information needed to verify their consistency. For procedures to back up or restore database files, refer to the “Maintain the Node” chapter in the *Cisco ONS 15454 DWDM Procedure Guide*.

## Clear the OCHNC-INC Alarm

- Step 1** To recreate the missing cross-connect itself, establish a Telnet connection with the node where it was deleted and use the ENT-WLEN command with the Add port, Drop port, or Express port on the node. For information about establishing a TL1 session connection, refer to the *Cisco ONS SONET TL1 Reference Guide*. For more information about ENT-WLEN and other TL1 commands, as well as their syntax, refer to the *Cisco ONS SONET TL1 Command Guide*.
- Step 2** If the alarm is not due to a deleted cross-connect but instead to an inconsistent database being restored on a node, correct the problem by restoring the correct backup version to that node. For the restore procedure, refer to the “Maintain the Node” chapter in the *Cisco ONS 15454 DWDM Procedure Guide*.

**Note**

When you restore a database on a node, it replaces the database being used on both (ACT and SBY) TCC2/TCC2P cards as the cards synchronize this version into their active flash memory. If the active (ACT) TCC2/TCC2P card is reset, the standby (SBY) TCC2/TCC2P card will therefore use the same database version from its active flash memory. In the case of a power-up, both TCC2/TCC2P cards boot and choose which database to use from two criteria: (1) the most recent version compatible with the node software, and (2) the most recently loaded version of that compatible database (with the highest sequence number).

- Step 3** If the alarm does not clear, log into the Technical Support Website at <http://www.cisco.com/techsupport> for more information or call Cisco TAC (1-800-553-2447) in order to report a Service-Affecting (SA) problem.

## 2.5.210 OCHTERM-INC

Default Severity: Not Reported (NR), Non-Service-Affecting (NSA)

Logical Object: OCHTERM

The Optical Termination Incomplete condition is raised against an OCH termination of there is no peer OCH termination at the other end of a span.

### Clear the OCHTERM-INC Condition

- Step 1** Create an OCH termination at the other end of the span. For procedures to do this, refer to the “Create Channels and Circuits” chapter in the *Cisco ONS 15454 DWDM Procedure Guide*.
- Step 2** If the condition does not clear, log into the Technical Support Website at <http://www.cisco.com/techsupport> for more information or call Cisco TAC (1-800-553-2447).

## 2.5.211 ODUK-1-AIS-PM

Default Severity: Not Reported (NR), Non-Service-Affecting (NSA)

Logical Object: TRUNK

The ODUK-1-AIS-PM is a secondary condition raised on MXP and ADM-10G cards trunk signals when they experience an LOS (2R). Although the ODUK-1-AIS-PM is raised against the TRUNK object, it actually refers to the client signals contained within the trunk.

A single ODUK-x-AIS-PM can occur when one far-end client signal is lost; multiple ODK-x-AIS-PMs can occur (ODUK-1-AIS-PM, ODUK-2-AIS-PM, ODUK-3-AIS-PM, ODUK-4-AIS-PM) if more than one far-end client is lost. If the entire trunk signal is lost, LOS (TRUNK) occurs and demotes any LOS (2R) alarms.

## Clear the ODUK-1-AIS-PM Condition

- 
- Step 1** Look for and clear the LOS (2R) alarm on the far-end client. This should clear the ODUK-1-AIS-PM condition on the trunk.
- Step 2** If the condition does not clear, log into the Technical Support Website at <http://www.cisco.com/techsupport> for more information or call Cisco TAC (1-800-553-2447).
- 

## 2.5.212 ODUK-2-AIS-PM

Default Severity: Not Reported (NR), Non-Service-Affecting (NSA)

Logical Object: TRUNK

The ODUK-2-AIS-PM is a secondary condition raised on MXP and ADM-10G cards trunk signals when they experience an LOS (2R). Although the ODUK-2-AIS-PM is raised against the TRUNK object, it actually refers to the client signals contained within the trunk.

## Clear the ODUK-2-AIS-PM Condition

- 
- Step 1** Complete the “[Clear the ODUK-1-AIS-PM Condition](#)” procedure on page 2-168.
- Step 2** If the condition does not clear, log into the Technical Support Website at <http://www.cisco.com/techsupport> for more information or call Cisco TAC (1-800-553-2447).
- 

## 2.5.213 ODUK-3-AIS-PM

Default Severity: Not Reported (NR), Non-Service-Affecting (NSA)

Logical Object: TRUNK

The ODUK-3-AIS-PM is a secondary condition raised on MXP and ADM-10G cards trunk signals when they experience an LOS (2R). Although the ODUK-3-AIS-PM is raised against the TRUNK object, it actually refers to the client signals contained within the trunk.

## Clear the ODUK-3-AIS-PM Condition

- 
- Step 1** Complete the “Clear the “[Clear the ODUK-1-AIS-PM Condition](#)” procedure on page 2-168.



- Step 2** If the condition does not clear, log into the Technical Support Website at <http://www.cisco.com/techsupport> for more information or call Cisco TAC (1-800-553-2447).
- 

## 2.5.214 ODUK-4-AIS-PM

Default Severity: Not Reported (NR), Non-Service-Affecting (NSA)

Logical Object: TRUNK

The ODUK-4-AIS-PM is a secondary condition raised on MXP and ADM-10G cards trunk signals when they experience an LOS (2R). Although the ODUK-4-AIS-PM is raised against the TRUNK object, it actually refers to the client signals contained within the trunk.

### Clear the ODUK-4-AIS-PM Condition

- Step 1** Complete the [“Clear the ODUK-1-AIS-PM Condition” procedure on page 2-168](#).
- Step 2** If the condition does not clear, log into the Technical Support Website at <http://www.cisco.com/techsupport> for more information or call Cisco TAC (1-800-553-2447).
- 

## 2.5.215 ODUK-AIS-PM

Default Severity: Not Reported (NR), Non-Service-Affecting (NSA)

Logical Object: TRUNK

The Optical Data Unit (ODUK) AIS Path Monitoring (PM) condition applies to TXP\_MR\_10G, TXP\_MR\_2.5G, TXPP\_MR\_2.5G, TXP\_MR\_10E, TXP\_MR\_10E\_C, TXP\_MR\_10E\_L, MXP\_2.5G\_10G, ADM-10G, and OTU2\_XP cards when ITU-T G.709 encapsulation is enabled for the cards. ODUK-AIS-PM is a secondary condition that indicates a more serious condition such as the LOS (OCN/STMN) alarm occurring downstream. (This is described in the “Alarm Troubleshooting” chapter of the *Cisco ONS 15454 Troubleshooting Guide* or the *Cisco ONS 15454SDH Troubleshooting Guide*.) The ODUK-AIS-PM condition is reported in the path monitoring area of the optical data unit wrapper overhead. ODUK-AIS-PM is caused by the upstream [2.5.218 ODUK-OCI-PM, page 2-171](#).

ITU-T G.709 encapsulation refers to a digital data wrapper that is transparent across networking standards such as SONET and protocols (such as Ethernet or IP). For information about provisioning the TXP card or MXP card to enable ITU-T G.709 encapsulation, refer to the “Provision Transponder and Muxponder Cards” chapter in the *Cisco ONS 15454 DWDM Procedure Guide*.



#### Note

For general information about MXP and TXP cards, refer to the “Card Reference” chapter in the *Cisco ONS 15454 DWDM Reference Manual*. For information about provisioning them, refer to the “Provision Transponder and Muxponder Cards” chapter in the *Cisco ONS 15454 DWDM Procedure Guide*.

---

## Clear the ODUK-AIS-PM Condition

- 
- Step 1** Determine whether upstream nodes and equipment have alarms, especially the LOS (OCN/STMN) alarm, or OOS (or Locked) ports.
  - Step 2** Clear the upstream alarms using the “Clear the LOS (OCN/STMN) Procedure” located in the *Cisco ONS 15454 Troubleshooting Guide* or *Cisco ONS 15454SDH Troubleshooting Guide*.
  - Step 3** If the condition does not clear, log into the Technical Support Website at <http://www.cisco.com/techsupport> for more information or call Cisco TAC (1-800-553-2447).
- 

## 2.5.216 ODUK-BDI-PM

Default Severity: Not Reported (NR), Non-Service-Affecting (NSA)

Logical Object: TRUNK

The ODUK Backward Defect Indicator (BDI) PM condition applies to TXP\_MR\_10G, TXP\_MR\_2.5G, TXPP\_MR\_2.5G, TXP\_MR\_10E, TXP\_MR\_10E\_C, TXP\_MR\_10E\_L, MXP\_2.5G\_10G, ADM-10G, and OTU2\_XP cards when ITU-T G.709 encapsulation is enabled for the cards. It indicates that there is a path termination error upstream in the data. The error is read as a BDI bit in the path monitoring area of the digital wrapper overhead.



### Note

For general information about MXP and TXP cards, refer to the “Card Reference” chapter in the *Cisco ONS 15454 DWDM Reference Manual*. For information about provisioning them, refer to the “Provision Transponder and Muxponder Cards” chapter in the *Cisco ONS 15454 DWDM Procedure Guide*.

---

## Clear the ODUK-BDI-PM Condition

- 
- Step 1** Complete the “[Clear the OTUK-BDI Condition](#)” procedure on page 2-180.
  - Step 2** If the condition does not clear, log into the Technical Support Website at <http://www.cisco.com/techsupport> for more information or call Cisco TAC (1-800-553-2447).
- 

## 2.5.217 ODUK-LCK-PM

Default Severity: Not Reported (NR), Non-Service-Affecting (NSA)

Logical Object: TRUNK

The ODUK Locked Defect (LCK) PM condition applies to TXP\_MR\_10G, TXP\_MR\_2.5G, TXPP\_MR\_2.5G, TXP\_MR\_10E, TXP\_MR\_10E\_C, TXP\_MR\_10E\_L, MXP\_2.5G\_10G, ADM-10G, and OTU2\_XP cards when ITU-T G.709 encapsulation is enabled for the cards. ODUK-LCK-PM indicates that a signal is being sent downstream to indicate that the upstream connection is locked, preventing the signal from being passed. The lock is indicated by the STAT bit in the path overhead monitoring fields of the optical transport unit overhead of the digital wrapper.

**Note**

---

For general information about MXP and TXP cards, refer to the “Card Reference” chapter in the *Cisco ONS 15454 DWDM Reference Manual*. For information about provisioning them, refer to the “Provision Transponder and Muxponder Cards” chapter in the *Cisco ONS 15454 DWDM Procedure Guide*.

---

## Clear the ODUK-LCK-PM Condition

- 
- Step 1** Unlock the upstream node signal.
- Step 2** If the condition does not clear, log into the Technical Support Website at <http://www.cisco.com/techsupport> for more information or call Cisco TAC (1-800-553-2447).
- 

## 2.5.218 ODUK-OCI-PM

Default Severity: Not Reported (NR), Non-Service-Affecting (NSA)

Logical Object: TRUNK

The ODUK Open Connection Indication (OCI) PM condition applies to TXP\_MR\_10G, TXP\_MR\_2.5G, TXPP\_MR\_2.5G, TXP\_MR\_10E, TXP\_MR\_10E\_C, TXP\_MR\_10E\_L, MXP\_2.5G\_10G, ADM-10G, and OTU2\_XP cards when ITU-T G.709 encapsulation is enabled for the cards. It indicates that the upstream signal is not connected to a trail termination source. The error is read as a STAT bit in the path monitoring area of the digital wrapper overhead. ODUK-OCI-PM causes a downstream “[ODUK-LCK-PM](#)” alarm on page 2-170.

**Note**

---

For general information about MXP and TXP cards, refer to the “Card Reference” chapter in the *Cisco ONS 15454 DWDM Reference Manual*. For information about provisioning them, refer to the “Provision Transponder and Muxponder Cards” chapter in the *Cisco ONS 15454 DWDM Procedure Guide*.

---

## Clear the ODUK-OCI-PM Condition

- 
- Step 1** Verify the fiber connectivity at nodes upstream.
- Step 2** If the condition does not clear, log into the Technical Support Website at <http://www.cisco.com/techsupport> for more information or call Cisco TAC (1-800-553-2447).
- 

## 2.5.219 ODUK-SD-PM

Default Severity: Not Alarmed (NA), Non-Service-Affecting (NSA)

Logical Object: TRUNK

The ODUK Signal Degrade (SD) PM condition applies to TXP\_MR\_10G, TXP\_MR\_2.5G, TXPP\_MR\_2.5G, TXP\_MR\_10E, TXP\_MR\_10E\_C, TXP\_MR\_10E\_L, MXP\_2.5G\_10G, ADM-10G, and OTU2\_XP cards when ITU-T G.709 encapsulation is enabled. ODUK-SD-PM indicates that incoming signal quality is poor, but the incoming line BER has not passed the fail threshold. The BER problem is indicated in the path monitoring area of the optical data unit frame overhead.

**Note**

For general information about MXP and TXP cards, refer to the “Card Reference” chapter in the *Cisco ONS 15454 DWDM Reference Manual*. For information about provisioning them, refer to the “Provision Transponder and Muxponder Cards” chapter in the *Cisco ONS 15454 DWDM Procedure Guide*.

## Clear the ODUK-SD-PM Condition

- 
- Step 1** Complete the “[Clear the OTUK-SD Condition](#)” procedure on page 2-183.
- Step 2** If the condition does not clear, log into the Technical Support Website at <http://www.cisco.com/techsupport> for more information or call Cisco TAC (1-800-553-2447).
- 

## 2.5.220 ODUK-SF-PM

Default Severity: Not Alarmed (NA), Non-Service-Affecting (NSA)

Logical Object: TRUNK

The ODUK Signal Fail (SF) PM condition (ODUK-SD-PM) applies to TXP\_MR\_10G, TXP\_MR\_2.5G, TXPP\_MR\_2.5G, MXP\_2.5G\_10G, ADM-10G, and OTU2\_XP cards when ITU-T G.709 encapsulation is enabled. ODUK-SF-PM indicates that incoming signal quality is poor and the incoming line BER has passed the fail threshold. The BER problem is indicated in the path monitoring area of the optical data unit frame overhead.

**Note**

For general information about MXP and TXP cards, refer to the “Card Reference” chapter in the *Cisco ONS 15454 DWDM Reference Manual*. For information about provisioning them, refer to the “Provision Transponder and Muxponder Cards” chapter in the *Cisco ONS 15454 DWDM Procedure Guide*.

## Clear the ODUK-SF-PM Condition

- 
- Step 1** Complete the “Clear the SF (DS1, DS3) Condition” procedure located in the “Alarm Troubleshooting” chapter of the *Cisco ONS 15454 Troubleshooting Guide*.
- Step 2** If the condition does not clear, log into the Technical Support Website at <http://www.cisco.com/techsupport> for more information or call Cisco TAC (1-800-553-2447).
-

## 2.5.221 ODUK-TIM-PM

Default Severity: Major (MJ), Service-Affecting (SA)

Logical Object: TRUNK

The ODUK-TIM- PM condition applies to the path monitoring area of the OTN overhead for TXP\_MR\_10G, TXP\_MR\_2.5G, TXPP\_MR\_2.5G, TXP\_MR\_10E, TXP\_MR\_10E\_C, TXP\_MR\_10E\_L, MXP\_2.5G\_10G, ADM-10G, and OTU2\_XP cards. The condition occurs when there is a trace identifier mismatch in the data stream. ODUK-TIM-PM causes an [2.5.216 ODUK-BDI-PM, page 2-170](#), downstream.

The ODUK-TIM-PM condition applies to TXP cards and MXP cards when ITU-T G.709 encapsulation is enabled for the cards. It indicates that there is an error upstream in the optical transport unit overhead of the digital wrapper.

ITU-T G.709 encapsulation refers to a digital data wrapper that is transparent across networking standards such as SONET and protocols (such as Ethernet or IP). For information about provisioning the TXP card or MXP card to enable ITU-T G.709 encapsulation, refer to the “Provision Transponder and Muxponder Cards” chapter in the *Cisco ONS 15454 DWDM Procedure Guide*.

**Note**

For general information about MXP and TXP cards, refer to the “Card Reference” chapter in the *Cisco ONS 15454 DWDM Reference Manual*. For information about provisioning them, refer to the “Provision Transponder and Muxponder Cards” chapter in the *Cisco ONS 15454 DWDM Procedure Guide*.

### Clear the ODUK-TIM-PM Condition

- 
- Step 1** Complete the “Clear the TIM-P Condition” procedure located in the “Alarm Troubleshooting” chapter of the *Cisco ONS 15454 Troubleshooting Guide*.
- Step 2** If the condition does not clear, log into the Technical Support Website at <http://www.cisco.com/techsupport> for more information or call Cisco TAC (1-800-553-2447).
- 

## 2.5.222 OPEN-SLOT

Default Severity: Not Alarmed (NA), Minor (MN)

Logical Object: EQPT

The Open Slot condition indicates that there is an open slot in the system shelf. Slot covers assist with airflow and cooling.

### Clear the OPEN-SLOT Condition

- 
- Step 1** To install a slot cover and clear this condition, refer to the procedures located in the “Install Shelf and Common Control Cards” chapter of the *Cisco ONS 15454 DWDM Procedure Guide*.

- Step 2** If the condition does not clear, log into the Technical Support Website at <http://www.cisco.com/techsupport> for more information or call Cisco TAC (1 800 553-2447).
- 

## 2.5.223 OPTNTWMIS

Default Severity: Major (MJ), Non-Service-Affecting (NSA)

Logical Object: NE

The Optical Network Type Mismatch alarm is raised when DWDM nodes are not configured for the same type of network, either MetroCore or MetroAccess. All DWDM nodes on the same network must be configured for the same network type because APC and ANS behave differently on each of these network types. For more information about APC and ANS, refer to the “Network Reference” chapter in the *Cisco ONS 15454 DWDM Reference Manual*.

When the OPTNTWMIS alarm occurs, the [“APC-DISABLED” alarm on page 2-29](#) could also be raised.



**Note**

For general information about DWDM cards, refer to the “Card Reference” chapter in the *Cisco ONS 15454 DWDM Reference Manual*. For information about provisioning them, refer to the “Change DWDM Card Settings” chapter in the *Cisco ONS 15454 DWDM Procedure Guide*.

---

### Clear the OPTNTWMIS Alarm

- Step 1** In node view (single-shelf mode) or multishelf view (multishelf mode) of the alarmed node, click the **Provisioning > WDM-ANS > Provisioning** tabs.
- Step 2** Choose the correct option from the Network Type list box, and click **Apply**.
- Step 3** If the alarm does not clear, log into the Technical Support Website at <http://www.cisco.com/techsupport> for more information or call Cisco TAC (1-800-553-2447).
- 

## 2.5.224 OPWR-HDEG

Default Severity: Minor (MN), Non-Service-Affecting (NSA)

Logical Objects: AOTS, OCH, OCH-TERM, OMS, OTS

The Output Power High Degrade alarm occurs on all DWDM ports that use a power setpoint, including the OPT-BST, OPT-PRE, OPT-AMP-C, and OPT-AMP-17-C cards AOTS ports in control-power mode; the 32DMX, 32DMX-O, 40DMX, 32MUX-O, 32WSS, 40WSS-C, and WXC card OCH ports; and the OSC-CSM and OSCM OSC-TX ports.

The alarm generally indicates that an internal signal transmission problem prevents the signal output power from maintaining its setpoint and the signal has crossed the high-degrade threshold. For 32DMX, 32DMX-O, 40DMX, 32MUX-O, 32WSS, 40WSS-C, WXC OCH ports and OSC-CSM and OSCM OSC-TX ports, OPWR-HDEG indicates that the card has a VOA control circuit failure affecting its attenuation capability. The alarmed card should be replaced at the next opportunity.

**Note**

For more information about provisioning gain setpoints and VOA setpoints, refer to the “Node Reference” and “Network Reference” chapters, respectively, of the *Cisco ONS 15454 DWDM Reference Manual*. The “Hardware Specifications” appendix in the same manual contains power level tables for each card.

## Clear the OPWR-HDEG Alarm

- Step 1** Verify fiber continuity to the port by following site practices. Refer to the “Network Reference” chapter of the *Cisco ONS 15454 DWDM Reference Manual* for a procedure to detect a fiber cut.
- Step 2** If the cabling is good, confirm that the LED is correctly illuminated on the physical card. A green ACT/SBY LED indicates an active card. A red ACT/SBY LED indicates a failed card.
- Step 3** Verify that the power read by photodiode on the port is within the expected range as projected by Cisco TransportPlanner. The application generates a spreadsheet of values containing this information.
- Step 4** If the optical power level is within specifications, check the opwrMin threshold. (These are listed in the “Hardware Specifications” appendix of the *Cisco ONS 15454 DWDM Reference Manual*.) Refer to the *Cisco MetroPlanner DWDM Operations Guide* and decide what value to use for modifying the power level:
- In node view (single-shelf mode) or shelf view (multishelf mode), double-click the card to open the card view.
  - Display the optical thresholds by clicking the following tabs:
    - For the OPT-BST, OPT-AMP-C, or OPT-AMP-17-C cards, click the Provisioning > Opt. Ampli. Line > Optics Thresholds tabs.
    - For the OPT-PRE, OPT-AMP-C, or OPT-AMP-17-C cards, click the Provisioning > Opt. Ampli. Line > Optics Thresholds tabs.
    - For the WXC card, click the Provisioning > Optical Chn > Optics Thresholds tabs.
    - For the AD-xC-xx.x card, click the Provisioning > Optical Chn > Optics Thresholds tabs.
    - For the AD-xB-xx.x card, click the Provisioning > Optical Band > Optics Thresholds tabs.
    - For the 32DMX, 32DMX-O, or 40DMX cards, click the Provisioning > Optical Chn > Optics Thresholds tabs.
    - For the 32MUX-O card, click the Provisioning > Optical Chn > Optics Thresholds tabs.
    - For the 32WSS card, click the Provisioning > Optical Chn: Optical Connector x > Optics Thresholds tabs.
    - For the OSCM or OSC-CSM cards, click the Provisioning > Optical Line > Optics Thresholds tabs.
- Step 5** If the received optical power level is within specifications, refer to the *Cisco MetroPlanner DWDM Operations Guide* to determine the correct levels and check the opwrMin threshold. (These are listed in the “Hardware Specifications” appendix of the *Cisco ONS 15454 DWDM Reference Manual*.) If necessary, modify the value as required.
- Step 6** If the optical power is outside of the expected range, verify that all involved optical signal sources, namely the TXP or MXP trunk port or an ITU-T line card, are in IS or Unlocked administrative state by clicking the correct tab:
- For the MXPP\_MR\_2.5G card, click the **Provisioning > Line > SONET** (or **Provisioning > Line > SDH**) tabs.

- For the MXP\_2.5G\_10E card, click the **Provisioning > Line > Trunk** tabs.
- For the MXP\_2.5G\_10G card, click the **Provisioning > Line > SONET** (or **Provisioning > Line > SDH**) tabs.
- For the MXP\_MR\_2.5G card, click the **Provisioning > Line > SONET** (or **Provisioning > Line > SDH**) tabs.
- For the TXPP\_MR\_2.5G card, click the **Provisioning > Line > SONET** (or **Provisioning > Line > SDH**) tabs.
- For the TXP\_MR\_10E card, click the **Provisioning > Line > SONET** (or **Provisioning > Line > SDH**) tabs.
- For the TXP\_MR\_10G card, click the **Provisioning > Line > SONET** (or **Provisioning > Line > SDH**) tabs.
- For the TXP\_MR\_2.5G card, click the **Provisioning > Line > SONET** (or **Provisioning > Line > SDH**) tabs.

If it is not IS or Unlocked, choose **IS (or Unlocked)** from the administrative state drop-down list. This creates the IS-NR or Unlocked,enabled service state.

- Step 7** If the port is in IS (or Unlocked) state but its output power is outside of the specifications, complete the [“Clear the LOS-P \(OCH\) Alarm” procedure on page 2-142](#). (These specifications are listed in the “Hardware Specifications” appendix of the *Cisco ONS 15454 DWDM Reference Manual*.)
- Step 8** If the signal source is IS or Unlocked and within expected range, come back to the unit reporting OPWR-HDEG and clean all connected fiber in the same line direction as the reported alarm according to site practice. If no site practice exists, complete the procedure in the “Maintain the Node” chapter of the *Cisco ONS 15454 DWDM Procedure Guide*.



**Note** Unplugging fiber can cause a traffic hit. To avoid this, perform a traffic switch if possible. Refer to the procedures in the [“2.8.2 Protection Switching, Lock Initiation, and Clearing” section on page 2-237](#). For more detailed protection switching information, refer to the “Manage the Node” chapter in the *Cisco ONS 15454 DWDM Procedure Guide*.

- Step 9** Repeat Steps 1 to 8 for any other port on the card reporting the OPWR-HDEG alarm.
- Step 10** If the alarm does not clear, look for and troubleshoot any other alarm that could identify the source of the problem.
- Step 11** If no other alarms exist that could be the source of the OPWR-HDEG, or if clearing an alarm did not clear the alarm, place all of the card ports in **OOS,DSBLD** (or **Locked,disabled**) administrative state.
- Step 12** Complete the [“Physically Replace a Card” procedure on page 2-244](#) for the reporting card.
- Step 13** If the alarm does not clear, log into the Technical Support Website at <http://www.cisco.com/techsupport> for more information or call Cisco TAC (1-800-553-2447).

## 2.5.225 OPWR-HFAIL

Default Severity: Critical (CR), Service-Affecting (SA)

Logical Objects: AOTS, OCH, OMS, OTS



The Output Power Failure alarm occurs on an amplifier card (OPT-BST, OPT-PRE, OPT-AMP-C, or OPT-AMP-17-C) AOTS and WXC card OCH port if the transmitted power exceeds the high fail threshold. This alarm is raised only in control power working mode. The alarmed card should be replaced at the next opportunity.

**Note**

For general information about DWDM cards, refer to the “Card Reference” chapter in the *Cisco ONS 15454 DWDM Reference Manual*. For information about changing their settings, refer to the “Change DWDM Card Settings” chapter in the *Cisco ONS 15454 DWDM Procedure Guide*.

## Clear the OPWR-HFAIL Alarm

- 
- Step 1** Complete the “[Clear the OPWR-HDEG Alarm](#)” procedure on page 2-175.
- Step 2** If the alarm does not clear, log into the Technical Support Website at <http://www.cisco.com/techsupport> for more information or call Cisco TAC (1-800-553-2447) in order to report a Service-Affecting (SA) problem.
- 

## 2.5.226 OPWR-LDEG

Default Severity: Minor (MN), Non-Service-Affecting (NSA)

Logical Objects: AOTS, OCH, OCH-TERM, OMS, OTS

The Output Power Low Degrade alarm occurs on all DWDM ports that use a setpoint, including the an amplifier card (OPT-BST, OPT-PRE, OPT-AMP-C, or OPT-AMP-17-C) AOTS ports in control-power mode; the 32DMX, 32DMX-O, 40DMX, 32MUX-O, 40MUX, 32WSS, and 40WSS-C card OCH ports; and the OSC-CSM and OSCM card OSC-TX ports.

The alarm generally indicates that an internal signal transmission problem prevents the signal output power from maintaining its setpoint and the signal has crossed the low degrade threshold. For the 32DMX, 32DMX-O, 40DMX, 32MUX-O, 40MUX, 32WSS, and 40WSS-C card OCH ports and the OSC-CSM and OSCM card OSC-TX ports, the OPWR-HDEG alarm indicates that the card has a VOA control circuit failure affecting its attenuation capability. The alarmed card should be replaced at the next opportunity.

**Note**

The OPWR-LDEG alarm may be raised on the WSS pass through ports of a ROADM configuration when the attenuation is increased at the span level.

**Note**

For general information about DWDM cards, refer to the “Card Reference” chapter in the *Cisco ONS 15454 DWDM Reference Manual*. For more information about provisioning VOA setpoints, refer to the “Network Reference” chapter in the same manual.

## Clear the OPWR-LDEG Alarm

- 
- Step 1** Complete the “[Clear the OPWR-HDEG Alarm](#)” procedure on page 2-175.

- Step 2** If the alarm does not clear, log into the Technical Support Website at <http://www.cisco.com/techsupport> for more information or call Cisco TAC (1-800-553-2447).
- 

## 2.5.227 OPWR-LFAIL

Default Severity: Critical (CR), Service-Affecting (SA)

Logical Objects: AOTS, OCH, OCH-TERM, OMS, OTS

The Output Power Failure alarm applies to an amplifier card (OPT-BST, OPT-PRE, OPT-AMP-C, or OPT-AMP-17-C) AOTS ports. It also applies to AD-1B-xx.x, AD-4B-xx.x, AD-1C-xx.x, AD-2C-xx.x, AD-4C-xx.x, OPT-PRE, OPT-BST, OPT-AMP-C, or OPT-AMP-17-C, 32MUX-O, 40MUX, 32DMX, 32DMX-O, 32DMX, 40DMX, 32WSS, 40WSS-C, and OSC-CSM transmit ports. The alarm is raised when monitored input power crosses the low fail threshold.

For the AD-1B-xx.x, AD-4B-xx.x, AD-1C-xx.x, AD-2C-xx.x, and AD-4C-xx.x card OCH ports and the 32MUX-O, 40MUX, 32DMX, 32DMX-O, 32DMX, 40DMX, 32WSS, 40WSS-C, OSCM, and OSC-CSM cards, OPWR-LFAIL indicates that the card has a VOA control circuit failure that affects its attenuation capability.



### Note

For general information about DWDM cards, refer to the “Card Reference” chapter in the *Cisco ONS 15454 DWDM Reference Manual*. For more information about provisioning VOA setpoints, refer to the “Network Reference” chapter in the same manual.

---

## Clear the OPWR-LFAIL Alarm

- Step 1** Complete the “[Clear the OPWR-HDEG Alarm](#)” procedure on page 2-175.
- Step 2** If the alarm does not clear, log into the Technical Support Website at <http://www.cisco.com/techsupport> for more information or call Cisco TAC (1-800-553-2447) in order to report a Service-Affecting (SA) problem.
- 

## 2.5.228 OSRIION

Default Severity: Not Alarmed (NA), Non-Service-Affecting (NSA)

Logical Objects: AOTS, OTS

The Optical Safety Remote Interlock On condition is raised on an amplifier card (OPT-BST or OPT-PRE) when OSRI is set to ON. The condition does not correlate with the “[OPWR-LFAIL](#)” alarm on page 2-178, which is also reported on the same port.

## Clear the OSRION Condition

- 
- Step 1** Turn the OSRI off:
- In node view (single-shelf mode) or shelf view (multishelf mode), double-click the card to open the card view.
  - Click the **Maintenance > ALS** tabs.
  - In the OSRI column, choose **OFF** from the drop-down list.
- Step 2** If the condition does not clear, log into the Technical Support Website at <http://www.cisco.com/techsupport> for more information or call Cisco TAC (1-800-553-2447).
- 

## 2.5.229 OTUK-AIS

Default Severity: Not Reported (NR), Non-Service-Affecting (NSA)

Logical Object: TRUNK

The Optical Transport Unit (OTUK) AIS condition applies to TXP\_MR\_10G, TXP\_MR\_2.5G, TXPP\_MR\_2.5G, TXP\_MR\_10E, TXP\_MR\_10E\_C, TXP\_MR\_10E\_L, MXP\_2.5G\_10G, MXP\_2.5G\_10E, ADM-10G, and OTU2\_XP cards when ITU-T G.709 encapsulation is enabled for the cards. OTUK-AIS is a generic AIS signal with a repeating AIS PN-11 sequence. This pattern is inserted by the card in the ITU-T G.709 frame (Trunk) when a faulty condition is present on the client side.

The detection of an OTUK-AIS on the RX-Trunk port of a near-end TXP or MXP is a secondary condition that indicates a more serious issue occurring on the far-end TXP/MXP card connected upstream, most likely on the client side. OTUK-AIS is reported in the optical transport unit overhead of the digital wrapper.

ITU-T G.709 encapsulation refers to a digital data wrapper that is transparent across networking standards such as SONET and protocols (such as Ethernet or IP).



**Note**

For information about MXP and TXP cards and their monitoring capabilities, refer to the “Card Reference” and “Provision Transponder and Muxponder Cards” chapters in the *Cisco ONS 15454 DWDM Procedure Guide*.

---

## Clear the OTUK-AIS Condition

- 
- Step 1** Complete the “[Clear the AIS Condition](#)” procedure on page 2-27.
- Step 2** If the alarm does not clear, log into the Technical Support Website at <http://www.cisco.com/techsupport> for more information or call Cisco TAC (1-800-553-2447).
- 

## 2.5.230 OTUK-BDI

Default Severity: Not Reported (NR), Non-Service-Affecting (NSA)

Logical Object: TRUNK

The Section Monitoring Backward Defect Indication (OTUK BDI) condition applies to TXP\_MR\_10G, TXP\_MR\_2.5G, TXPP\_MR\_2.5G, TXP\_MR\_10E, TXP\_MR\_10E\_C, TXP\_MR\_10E\_L, MXP\_2.5G\_10G, MXP\_2.5G\_10E, ADM-10G, and OTU2\_XP cards when ITU-T G.709 encapsulation feature is enabled for the cards. The presence of OTUK-BDI is detected by ITU-T G.709 frame section-monitoring overhead field. The BDI bit is a single bit defined to convey the signal fail status detected in a section termination sink in the upstream direction.

**Note**

If the near-end TXP detects an OTUK-BDI condition on its Trunk-RX port, this means that the far-end TXP has inserted the BDI bit in the transmitted (Trunk-Tx) frame, because a failure such as LOS or SD was detected on the Trunk-RX port. Troubleshoot the failure on the far-end side to clear this condition. For information about various DWDM LOS alarms, refer to the appropriate sections in this chapter. For an OC-N/STM-N LOS failure or an SD, refer to the “Alarm Troubleshooting” chapter of the *Cisco ONS 15454 Troubleshooting Guide*.

ITU-T G.709 encapsulation refers to a digital data wrapper that is transparent across networking standards such as SONET and protocols (such as Ethernet or IP).

**Note**

For general information about MXP and TXP cards, refer to the “Card Reference” chapter in the *Cisco ONS 15454 DWDM Reference Manual*. For information about provisioning them, refer to the “Provision Transponder and Muxponder Cards” chapter in the *Cisco ONS 15454 DWDM Procedure Guide*.

## Clear the OTUK-BDI Condition

- 
- Step 1** At the near-end node, use site practices to clean trunk transmitting fiber toward the far-end node and the client receiving fiber. If no site practice exists, complete the procedure in the “Maintain the Node” chapter of the *Cisco ONS 15454 DWDM Procedure Guide*.
  - Step 2** At the far-end node, determine whether an [“OTUK-AIS” condition, page 2-179](#), is present on the Trunk-RX. If so, the root cause to be investigated is the Trunk-Tx side on the near-end card (the one alarmed for OTUK-BDI) because that is the section where the AIS bit is inserted.
  - Step 3** If there is no OTUK-AIS at the far-end node, continue to investigate performances of the Trunk-Rx: Look for other OTU-related alarms, such as the [“OTUK-LOF” condition on page 2-181](#) or [“OTUK-SD” condition on page 2-182](#) at the far-end Trunk-RX. If either is present, resolve the condition using the appropriate procedure in this chapter.
  - Step 4** If the OTUK-BDI alarm does not clear, use an OTN test set such as the Agilent OmniBerOTN tester to check near-end transmitting signal quality. (For specific procedures to use the test set equipment, consult the manufacturer.)
  - Step 5** If the condition does not clear, log into the Technical Support Website at <http://www.cisco.com/techsupport> for more information or call Cisco TAC (1-800-553-2447).
- 

## 2.5.231 OTUK-IAE

Default Severity: Minor (MN), Non-Service-Affecting (NSA)

Logical Object: TRUNK

The OTUK Section-Monitoring Incoming Alignment Error (IAE) alarm occurs on TXP\_MR\_10G, TXP\_MR\_2.5G, TXPP\_MR\_2.5G, TXP\_MR\_10E, TXP\_MR\_10E\_C, TXP\_MR\_10E\_L, MXP\_2.5G\_10G, MXP\_2.5G\_10E, ADM-10G, and OTU2\_XP cards when ITU-T G.709 encapsulation is enabled for the cards and the trunk connection is present. This alarm is raised on the near-end node to indicate that the far-end node it has detected errors in the received OTUK frames, but they are not bad enough to cause an “OTUK-LOF” alarm, page 2-181.

The IAE bit in the section overhead allows the ingress point (in this case, the far-end node) to inform its corresponding egress (near-end) point that the alignment error is detected on the incoming signal OTUK frame alignment errors from NE. The error is an out-of-frame (OOF) alignment, in which the optical transport unit overhead frame alignment (FAS) area is errored for more than five frames.

**Note**

For general information about MXP and TXP cards, refer to the “Card Reference” chapter in the *Cisco ONS 15454 DWDM Reference Manual*. For information about provisioning them, refer to the “Provision Transponder and Muxponder Cards” chapter in the *Cisco ONS 15454 DWDM Procedure Guide*.

## Clear the OTUK-IAE Alarm

- Step 1** At the near-end and far-end node, use site practices to clean transmitting fiber on near-end node's reporting port and receiving fiber on correspondent far-end port. If no site practice exists, complete the procedure in the “Maintain the Node” chapter of the *Cisco ONS 15454 DWDM Procedure Guide*.
- Step 2** If the OTUK-IAE alarm does not clear, look for other OTU-related alarm, such as the “OTUK-LOF” alarm, page 2-181, at the far-end node and resolve it using the appropriate procedure in this guide.
- Step 3** If the OTUK-IAE alarm does not clear, use an OTN test set such as the Agilent OmniBerOTN tester to check near-end transmitting signal quality. For specific procedures to use the test set equipment, consult the manufacturer.
- Step 4** If the alarm does not clear, log into the Technical Support Website at <http://www.cisco.com/techsupport> for more information or call Cisco TAC (1-800-553-2447).

## 2.5.232 OTUK-LOF

Default Severity: Critical (CR), Service-Affecting (SA)

Logical Object: TRUNK

The OTUK-LOF alarm applies to TXP\_MR\_10G, TXP\_MR\_2.5G, TXPP\_MR\_2.5G, TXP\_MR\_10E, TXP\_MR\_10E\_C, TXP\_MR\_10E\_L, MXP\_2.5G\_10G, MXP\_2.5G\_10E, GE-XP, 10GE-XP, ADM-10G, and OTU2\_XP cards when ITU-T G.709 encapsulation is enabled for the cards. The alarm indicates that the card has lost frame delineation on the input data. Loss of frame occurs when the optical transport unit overhead frame alignment (FAS) area is errored for more than five frames and that the error persists more than three milliseconds.

ITU-T G.709 encapsulation refers to a digital data wrapper that is transparent across networking standards such as SONET and protocols (such as Ethernet or IP).

**Note**

For general information about MXP and TXP cards, refer to the “Card Reference” chapter in the *Cisco ONS 15454 DWDM Reference Manual*. For information about provisioning them, refer to the “Provision Transponder and Muxponder Cards” chapter in the *Cisco ONS 15454 DWDM Procedure Guide*.

## Clear the OTUK-LOF Alarm

**Step 1** Verify cabling continuity to the port reporting the alarm.

**Caution**

Always use the supplied electrostatic discharge wristband when working with a powered ONS system. Plug the wristband cable into the ESD jack located on the lower-right edge of the shelf assembly. To verify cable continuity, follow site practices.

**Step 2** At the far-end node, verify the cabling of the Trunk-TX port of the TXP or MXP connected to alarmed card in the near-end. Clean the fibers according with site practice.(If no site practice exists, refer to the “Maintain the Node” chapter of the *Cisco ONS 15454 DWDM Procedure Guide* for procedures.)

**Step 3** At the far-end node, verify the ITU-T G.709 encapsulation configuration of the Trunk-TX of the TXP/MXP connected to alarmed card in the near end.

**Step 4** Look for other OTU-related alarms at the far-end Trunk-TX and resolve them if necessary using the appropriate procedure in this guide.

**Step 5** If the OTUK-LOF alarm does not clear on the near end, use an OTN test set such as the Agilent OmniBer OTN tester to check far-end ITU-T G.709 transmitting signal quality. (For specific procedures to use the test set equipment, consult the manufacturer.)

**Step 6** If the alarm does not clear, log into the Technical Support Website at <http://www.cisco.com/techsupport> for more information or call Cisco TAC (1-800-553-2447).

## 2.5.233 OTUK-SD

Default Severity: Not Alarmed (NA) Non-Service-Affecting (NSA)

Logical Object: TRUNK

The OTUK-SD condition applies to TXP\_MR\_10G, TXP\_MR\_2.5G, TXPP\_MR\_2.5G, TXP\_MR\_10E, TXP\_MR\_10E\_C, TXP\_MR\_10E\_L, MXP\_2.5G\_10G, MXP\_2.5G\_10E, ADM-10G, and OTU2\_XP cards when ITU-T G.709 encapsulation is enabled. The condition indicates that incoming signal quality is poor, but the incoming line BER has not passed the fail threshold. The BER value is calculated on the Trunk-Rx port’s incoming ITU-T G.709 encapsulation frame. If FEC or E-FEC feature is enabled, the BER is a pre-FEC measurement.

ITU-T G.709 encapsulation refers to a digital data wrapper that is transparent across networking standards such as SONET and protocols (such as Ethernet or IP).

**Note**

For general information about MXP and TXP cards, refer to the “Card Reference” chapter in the *Cisco ONS 15454 DWDM Reference Manual*. For information about provisioning them, refer to the “Provision Transponder and Muxponder Cards” chapter in the *Cisco ONS 15454 DWDM Procedure Guide*.

## Clear the OTUK-SD Condition

- 
- Step 1** Ensure that the fiber connector for the card is completely plugged in. For more information about fiber connections and card insertion, refer to the “Turn Up a Node” chapter in the *Cisco ONS 15454 DWDM Procedure Guide*.
  - Step 2** If the BER threshold is correct and at the expected level, use an optical test set to measure the power level of the line to ensure it is within guidelines. For specific procedures to use the test set equipment, consult the manufacturer.
  - Step 3** If the optical power level is good, verify that optical receive levels are within the acceptable range.
  - Step 4** If receive levels are good, clean the fibers at both ends according to site practice. If no site practice exists, complete the procedure in the “Maintain the Node” chapter in the *Cisco ONS 15454 DWDM Procedure Guide*.
  - Step 5** If the condition does not clear, verify that single-mode fiber is used.
  - Step 6** If the fiber is of the correct type, verify that a single-mode laser is used at the far-end node.
  - Step 7** Clean the fiber connectors at both ends for a signal degrade according to site practice.
  - Step 8** Verify that a single-mode laser is used at the far end.
  - Step 9** If the problem does not clear, the transmitter at the other end of the optical line could be failing and require replacement. Refer to the “2.8.4 Physical Card Reseating, Resetting, and Replacement” section on page 2-242.
  - Step 10** If the condition does not clear, log into the Technical Support Website at <http://www.cisco.com/techsupport> for more information or call Cisco TAC (1-800-553-2447).
- 

## 2.5.234 OTUK-SF

Default Severity: Not Alarmed (NA), Non-Service-Affecting (NSA)

Logical Object: TRUNK

The OTUK-SF condition applies to TXP\_MR\_10G, TXP\_MR\_2.5G, TXPP\_MR\_2.5G, TXP\_MR\_10E, TXP\_MR\_10E\_C, TXP\_MR\_10E\_L, MXP\_2.5G\_10G, MXP\_2.5G\_10E, ADM-10G, and OTU2\_XP cards when ITU-T G.709 encapsulation is enabled. The condition indicates that incoming signal quality is poor and that the BER for the incoming line has passed the fail threshold. The BER value is calculated on the Trunk-Rx port’s incoming ITU-T G.709 encapsulation frame. If FEC or E-FEC feature is enabled, the BER is a pre-FEC measurement.

ITU-T G.709 encapsulation refers to a digital data wrapper that is transparent across networking standards such as SONET and protocols (such as Ethernet or IP).

**Note**

For general information about MXP and TXP cards, refer to the “Card Reference” chapter in the *Cisco ONS 15454 DWDM Reference Manual*. For information about provisioning them, refer to the “Provision Transponder and Muxponder Cards” chapter in the *Cisco ONS 15454 DWDM Procedure Guide*.

## Clear the OTUK-SF Condition

- 
- Step 1** Complete the “[Clear the OTUK-SD Condition](#)” procedure on page 2-183.
- Step 2** If the condition does not clear, log into the Technical Support Website at <http://www.cisco.com/techsupport> for more information or call Cisco TAC (1-800-553-2447).
- 

## 2.5.235 OTUK-TIM

Default Severity: Critical (CR), Service-Affecting (SA)

Logical Object: TRUNK

The OTUK-TIM alarm applies to TXP\_MR\_10G, TXP\_MR\_2.5G, TXPP\_MR\_2.5G, TXP\_MR\_10E, TXP\_MR\_10E\_C, TXP\_MR\_10E\_L, MXP\_2.5G\_10G, MXP\_2.5G\_10E, ADM-10G, and OTU2\_XP cards when ITU-T G.709 encapsulation is enabled and section trace mode is set to manual. The alarm indicates that the expected section-monitoring trail trace identifier (TT1) string does not match the received TTI string and raises a Trace Identifier Mismatch (TIM) alarm. The TIM alarm in turn, triggers an “[OTUK-BDI](#)” alarm, page 2-179.

ITU-T G.709 encapsulation refers to a digital data wrapper that is transparent across networking standards such as SONET and protocols (such as Ethernet or IP).

**Note**

For general information about MXP and TXP cards, refer to the “Card Reference” chapter in the *Cisco ONS 15454 DWDM Reference Manual*. For information about provisioning them, refer to the “Provision Transponder and Muxponder Cards” chapter in the *Cisco ONS 15454 DWDM Procedure Guide*.

## Clear the OTUK-TIM Condition

- 
- Step 1** Complete the “[Clear the TIM Alarm](#)” procedure on page 2-222.
- Step 2** If the condition does not clear, log into the Technical Support Website at <http://www.cisco.com/techsupport> for more information or call Cisco TAC (1-800-553-2447).
- 

## 2.5.236 OUT-OF-SYNC

Default Severity: Major (MJ), Service-Affecting (SA); Not Alarmed (NA), Non-Service-Affecting (NSA) for ISC



Logical Objects: FC, GE, ISC, TRUNK

The Ethernet Out of Synchronization condition occurs on TXP\_MR\_2.5, TXPP\_MR\_2.5, GE-XP, 10GE-XP, and ADM-10G cards when the PPM (SFP) port is not correctly configured for the Gigabit Ethernet payload rate.



**Note**

For general information about MXP and TXP cards, refer to the “Card Reference” chapter in the *Cisco ONS 15454 DWDM Reference Manual*. For information about provisioning them, refer to the “Provision Transponder and Muxponder Cards” chapter in the *Cisco ONS 15454 DWDM Procedure Guide*.

## Clear the OUT-OF-SYNC Condition

- 
- Step 1** In node view (single-shelf mode) or shelf view (multishelf mode), double-click the alarmed card to open the card view.
- Step 2** Click the **Provisioning > Pluggable Port Modules** tabs.
- Step 3** Delete the provisioning for the PPM (SFP) by completing the following steps:
- Click the PPM (SFP) in the Selected PPM area.
  - Click **Delete**.
- Step 4** Recreate the PPM (SFP):
- In the Pluggable Port Modules area, click **Create**.
  - In the Create PPM dialog box, choose the PPM (SFP) number you want to create.
  - Click **OK**.
- Step 5** After the PPM (SFP) is created, provision the port’s data rate:
- In the Pluggable Ports area, click **Create**.
  - In Create Port dialog box, choose **ONE\_GE** from the Port Type drop-down list.
  - Click **OK**.
- Step 6** If the condition does not clear, log into the Technical Support Website at <http://www.cisco.com/techsupport> for more information or call Cisco TAC (1-800-553-2447).
- 

## 2.5.237 PARAM-MISM

Default Severity: Not Alarmed (NA), Non-Service-Affecting (NSA)

Logical Objects: AOTS, OCH, OCH-TERM, OMS, OTS

The Plug-in Module Range Settings Mismatch condition is raised on an amplifier card (OPT-BST, OPT-PRE, OPT-AMP-C, and OPT-AMP-17-C), optical add-drop multiplexer (OADM) card (AD-1C-xx.x, AD-2C-xx.x, AD-4C-xx.x, AD-1B-xx.x, and AD-4B-xx.x), multiplexer card (32MUX-O, 32WSS, 40WSS-C, and 40WXC), or demultiplexer cards (32DMX-O, 32DMX, 40-DMX-C, and 40DMX-CE) when the parameter range values stored on the card are different from the parameters stored in TCC2/TCC2P card database. The condition is not user-serviceable. Log into the Technical Support Website at <http://www.cisco.com/techsupport> for more information or call Cisco TAC (1-800-553-2447).

## 2.5.238 PDI-P

Default Severity: Not Alarmed (NA), Non-Service-Affecting (NSA)

Logical Object: STSMON, STSTRM

PDI-P is a set of application-specific codes indicating a signal label mismatch failure (SLMF) in the ONS 15454 STS path overhead. The condition indicates to downstream equipment that there is a defect in one or more of the directly mapped payloads contained in that STS synchronous payload envelope (SPE). For example, the mismatch could occur in the overhead to the path selector in a downstream node configured as part of a path protection. The PDI-P codes appear in the STS Signal Label (C2 byte).

An SLMF often occurs when the payload (for example, ATM) does not match what the signal label is reporting. The “AIS” condition, page 2-26 often accompanies a PDI-P condition. If the PDI-P is the only condition reported with the AIS, clearing PDI-P clears the AIS. PDI-P can also occur during an upgrade, but usually clears itself and is not a valid condition.

A PDI-P condition reported on an OC-N port supporting a G-Series card circuit could result from the end-to-end Ethernet link integrity feature of the G-Series card. If the link integrity is the cause of the path defect, it is typically accompanied by the TPTFAIL (G1000) or the CARLOSS (G1000) reported against one or both Ethernet ports terminating the circuit. If this is the case, clear the TPTFAIL and CARLOSS alarms to resolve the PDI-P condition.

A PDI-P condition reported on an OC-N port supporting an ML-Series card circuit could result from the end-to-end Ethernet link integrity feature of the ML-Series card. If the link integrity is the cause, it is typically accompanied by the TPTFAIL (ML100T, ML1000, MLFX) reported against one or both POS ports terminating the circuit. If TPTFAIL is reported against one or both of the POS ports, troubleshooting the accompanying alarm clears the PDI-P condition. Refer to the *Ethernet Card Software Feature and Configuration Guide for the Cisco ONS 15454, Cisco ONS 15454 SDH, and Cisco ONS 15327* for more information about ML-Series cards.



**Warning**

**On the OC-192 card, the laser is on when the card is booted and the safety key is in the on position (labeled 1). The port does not have to be in service for the laser to be on. The laser is off when the safety key is off (labeled 0).** Statement 293



**Warning**

**Invisible laser radiation could be emitted from the end of the unterminated fiber cable or connector. Do not stare into the beam directly with optical instruments. Viewing the laser output with certain optical instruments (for example, eye loupes, magnifiers, and microscopes) within a distance of 100 mm could pose an eye hazard.** Statement 1056



**Warning**

**Use of controls, adjustments, or performing procedures other than those specified could result in hazardous radiation exposure.** Statement 1057



**Note**

For more information about Ethernet cards, refer to the *Ethernet Card Software Feature and Configuration Guide for the Cisco ONS 15454, Cisco ONS 15454 SDH, and Cisco ONS 15327*.

## Clear the PDI-P Condition

- 
- Step 1** Verify that all circuits terminating in the reporting card are DISCOVERED:
- Click the **Circuits** tab.
  - Verify that the **Status** column lists the circuit as active.
  - If the Status column lists the circuit as PARTIAL, wait 10 minutes for the ONS 15454 to initialize fully. If the PARTIAL status does not change after full initialization, log into the Technical Support Website at <http://www.cisco.com/techsupport> for more information or call Cisco TAC to report a Service-Affecting (SA) problem (1-800-553-2447).

- Step 2** After determining that the circuit is DISCOVERED, ensure that the signal source to the card reporting the alarm is working.



**Caution** Always use the supplied electrostatic discharge wristband when working with a powered ONS 15454. Plug the wristband cable into the ESD jack located on the lower-right edge of the shelf assembly.

---

- Step 3** If traffic is affected, complete the [“Delete a Circuit” procedure on page 2-245](#).



**Caution** Deleting a circuit can affect existing traffic.

---

- Step 4** Recreate the circuit with the correct circuit size. Refer to the “Create Circuits and VT Tunnels” chapter in the *Cisco ONS 15454 Procedure Guide* for detailed procedures to create circuits.

- Step 5** If circuit deletion and re-creation does not clear the condition, verify that there is no problem stemming from the far-end OC-N card providing STS payload to the reporting card.

- Step 6** If the condition does not clear, confirm the cross-connect between the OC-N card and the reporting card.

- Step 7** If the condition does not clear, clean the far-end optical fiber according to site practice. If no site practice exists, complete the procedure in the “Maintain the Node” chapter of the *Cisco ONS 15454 Procedure Guide*.

- Step 8** If the condition does not clear, complete the [“Physically Replace a Card” procedure on page 2-244](#) for the optical/electrical cards.

- Step 9** If the condition does not clear, log into the Technical Support Website at <http://www.cisco.com/techsupport> for more information or call Cisco TAC (1-800-553-2447).
- 

## 2.5.239 PEER-NORESPONSE

Default Severity: Major (MJ), Non-Service-Affecting (NSA)

Logical Object: EQPT

The switch agent raises a Peer Card Not Responding alarm if either traffic card in a protection group does not receive a response to the peer status request message. PEER-NORESPONSE is a software failure and occurs at the task level, as opposed to a communication failure, which is a hardware failure between peer cards.

## Clear the PEER-NORESPONSE Alarm

- 
- Step 1** Complete the “[Reset a Card in CTC](#)” procedure on page 2-241 for the reporting card.
- Step 2** Verify that the reset is complete and error-free and that no new related alarms appear in CTC. Verify the LED appearance: A green ACT/SBY LED indicates an active card. An amber ACT/SBY LED indicates a standby card.
- Step 3** If the alarm does not clear, log into the Technical Support Website at <http://www.cisco.com/techsupport> for more information or call Cisco TAC (1-800-553-2447).
- 

## 2.5.240 PMI

Default Severity: Not Alarmed (NA), Non-Service-Affecting (NSA)

Logical objects: OCH, OMS, OTS

The Payload Missing Indication (PMI) condition is part of MSTP network-level alarm correlation. It is raised at the far end when OTS or OMS optical payload is missing due to an LOS, LOS-P, or OPWR-LFAIL alarm root cause. A single PMI condition is sent when every channel on the aggregated port is lost--that is, when there are no pass-through channels or active added channels in service.

An LOS, LOS-P, or OPWR-LFAIL alarm on an MSTP circuit causes multiple alarms for each channel. R7.0 correlation simplifies troubleshooting by reporting a single alarm for multiple alarms having one root cause, then demoting the root alarms so that they are only visible in the Conditions window (with Not Reported [NR] severity.)

PMI clears when the optical channel is working on the aggregated or single-channel optical port.



### Note

Network-level alarm correlation is only supported for MSTP communication alarms. It is not supported for equipment alarms.

---

## Clear the PMI Condition

- 
- Step 1** Clear the root-cause service-affecting alarm by using one of the following procedures, as appropriate:
- “[Clear the LOS \(OTS\) Alarm](#)” procedure on page 2-136
  - “[Clear the LOS \(TRUNK\) Alarm](#)” procedure on page 2-137
  - “[Clear the LOS-P \(OCH\) Alarm](#)” procedure on page 2-142
  - “[Clear the LOS-P \(AOTS, OMS, OTS\) Alarm](#)” procedure on page 2-139
  - “[Clear the LOS-P \(TRUNK\) Alarm](#)” procedure on page 2-146
  - “[Clear the OPWR-LFAIL Alarm](#)” procedure on page 2-178
- Step 2** If the alarm does not clear, log into the Technical Support Website at <http://www.cisco.com/techsupport> for more information or call Cisco TAC (1-800-553-2447).
-

## 2.5.241 PORT-FAIL

Default Severity: Critical (CR), Service-Affecting (SA)

Logical Object: OCH

The APC Port Failure alarm occurs when amplifier margins and VOA are saturated for a port, so APC cannot apply any control. For example, it is raised if APC attempts to set an OPT-BST or OPT-AMP-x-C port's gain higher than 20 dBm (the maximum setpoint) or its attenuation on Express VOA lower than 0 dBm (the minimum setpoint).

**Note**

For more information about provisioning VOA setpoints, refer to the “Network Reference” chapter of the *Cisco ONS 15454 DWDM Reference Manual*.

### Clear the PORT-FAIL Alarm

- Step 1** If a maintenance operation such as fiber repair, adding a card, or replacing a card has just been performed on the optical network (whether at the node raising the PORT-FAIL alarm or at any other node), determine whether this operation has added extra loss. This can happen if the repair is imperfect or if a patchcord is dirty. To test for signal loss, refer to procedures in the “Network Reference” chapter of the *Cisco ONS 15454 DWDM Reference Manual*.
- Step 2** If there is loss added and fiber has been repaired or removed, first try cleaning the fiber by completing the procedures in the “Maintain the Node” chapter of the *Cisco ONS 15454 DWDM Procedure Guide*.
- Step 3** If the alarm does not clear and fiber has been repaired, perform the repair again with new fiber if necessary. For fibering procedures, refer to the “Turn Up a Node” chapter in the *Cisco ONS 15454 DWDM Procedure Guide*. If the alarm does not clear, go to [Step 4](#).

**Warning**

**Invisible laser radiation may be emitted from the end of the unterminated fiber cable or connector. Do not view directly with optical instruments. Viewing the laser output with certain optical instruments (for example, eye loupes, magnifiers, and microscopes) within a distance of 100 mm may pose an eye hazard. Statement 1056**

**Note**

Before disconnecting any optical amplifier card fiber for troubleshooting, ensure that the optical amplifier card is unplugged.

- Step 4** If a maintenance operation has not been recently executed on the network, the alarm indicates that the network has consumed all of its allocated aging margins. In this case, log into the Technical Support Website at <http://www.cisco.com/techsupport> for more information or call Cisco TAC (1-800-553-2447) in order to report a Service-Affecting (SA) problem.

## 2.5.242 PROTNA

Default Severity: Minor (MN), Non-Service-Affecting (NSA)

Logical Object: EQPT

The Protection Unit Not Available alarm is caused by an OOS (or Locked) protection card when a TCC2/TCC2P card or cross-connect card that has been provisioned as part of a protection group is not available. The alarm clears if the device or facility is brought back in service.

## Clear the PROTNA Alarm

- 
- Step 1** If the PROTNA alarm occurs and does not clear, and if it is raised against a controller card, ensure that there is a redundant TCC2/TCC2P card installed and provisioned in the chassis.
- Step 2** If the alarm is raised against a line card, verify that the ports have been taken out of service (OOS,MT or Locked,maintenance):
- a. In node view (single-shelf mode) or shelf view (multishelf mode), double-click the reporting card to open the card view.
  - b. Click the **Provisioning** tab.
  - c. Click the administrative state of any in-service (IS or Unlocked) ports.
  - d. Choose **OOS,MT** (or **Locked,maintenance**) to take the ports out of service.
- Step 3** Complete the “[Reset a Card in CTC](#)” procedure on page 2-241 for the reporting card.
- Step 4** Verify that the reset is complete and error-free and that no new related alarms appear in CTC. Verify the LED appearance: A green ACT/SBY LED indicates an active card. An amber ACT/SBY LED indicates a standby card.
- Step 5** If the alarm does not clear, complete the “[Remove and Reinsert \(Reseat\) Any Card](#)” procedure on page 2-243 for the reporting card.
- Step 6** If the alarm does not clear, log into the Technical Support Website at <http://www.cisco.com/techsupport> for more information or call Cisco TAC (1-800-553-2447).
- 

## 2.5.243 PROV-MISMATCH

Default Severity: Minor (MN), Non-Service-Affecting (NSA)

Logical Object: PPM

The Provisioning Mismatch for a PPM alarm is raised against a PPM connector on MXP\_2.5G\_10E, MXP\_2.5G\_10E\_C, MXP\_2.5G\_10E\_L, MXP\_2.5G\_10G, MXP\_MR\_2.5G, MXPP\_MR\_2.5G, TXP\_MR\_2.5G, TXP\_MR\_10E, TXP\_MR\_10E\_C, TXP\_MR\_10E\_L, TXPP\_MR\_2.5G, GE\_XP, 10GE\_XP, ADM-10G, and OTU2\_XP under one of the following circumstances:

- The physical PPM’s range or wavelength does not match the provisioned value. PPMs have static wavelength values which must match the wavelengths provisioned for the card in the case of non-DWDM PPMs.
- The PPM’s reach (loss) value does not meet the reach value needed for the card.
- The reach of the inserted PPM does not match the physical PPM.

This alarm is raised on GE\_XP and 10GE\_XP cards, if the following settings are configured:

- Double Add and Translate Add selective modes
- CVLAN Ingress CoS
- MAC address learning on SVLAN

Until this alarm is cleared, provisioning on the GE\_XP and 10GE\_XP cards is not possible.

## Clear the PROV-MISMATCH Alarm

To clear the alarm when the physical PPM's range or wavelength does not match the provisioned value, perform the following steps:

- 
- Step 1** Determine what the PPM wavelength range should be by viewing the frequency provisioned for the card:
- In node view (single-shelf mode) or shelf view (multishelf mode), double-click the card to open the card view.
  - Click the **Maintenance > Info** tabs.
  - Record the value shown in the **Value** column.
- Step 2** Remove the incorrect PPM connector:
- Unplug the PPM connector and fiber from the reporting card.
  - If the PPM connector has a latch securing the fiber cable, pull the latch upward to release the cable.
  - Pull the fiber cable straight out of the connector.
- Step 3** Replace the unit with the correct PPM connector:
- Plug the fiber into a Cisco-supported PPM connector. For more information about supported PPMs, refer to the "Hardware Specifications" appendix of the *Cisco ONS 15454 DWDM Reference Manual*.
  - If the new PPM connector has a latch, close the latch over the cable to secure it.
  - Plug the cabled PPM connector into the card port until it clicks.
- 

To clear the alarm when the PPM's reach (loss) value does not meet the reach value needed for the card, perform the following steps:

- 
- Step 1** Determine what the reach distance of the PPM should be by viewing the reach value provisioned for the card:
- In node view (single-shelf mode) or shelf view (multishelf mode), double-click the card to open the card view.
  - Click the **Provisioning > Line** tabs.



**Note** In GE\_XP cards, click **Provisioning > Ether Ports** tabs.

---

- Record the value shown in the **Reach** column.
- Step 2** Check the reach value of the PPM:
- In the node view (single-shelf mode), click the **Inventory** tab.
  - Check the reach distance in the **Product ID** column.
- Step 3** If there is a mismatch in the values recorded in step1c and step2b, change the PPM to match the provisioned value or reprovision the card.

- Step 4** If the alarm does not clear, log into the Technical Support Website at <http://www.cisco.com/techsupport> for more information or call Cisco TAC (1-800-553-2447).

---

To clear the alarm on GE\_XP or 10GE\_XP cards with Double Add and Translate Add selective modes, CVLAN Ingress CoS, or MAC address learning on SVLAN configuration, perform the following steps:

- Step 1** Remove Double Add and Translate Add selective modes, CVLAN Ingress CoS, or MAC address learning on SVLAN configuration.
- Step 2** If the alarm does not clear, log into the Technical Support Website at <http://www.cisco.com/techsupport> for more information or call Cisco TAC (1-800-553-2447).

## 2.5.244 PTIM

Default Severity: Major (MJ), Non-Service-Affecting (NSA)

Logical Object: TRUNK, EQPT

The Payload Type Identifier Mismatch alarm occurs when there is a mismatch between the way the ITU-T G.709 encapsulation option is configured on MXP\_2.5G\_10G, TXP\_MR\_10G, TXP\_MR\_2.5G, TXP\_MR\_10E, TXP\_MR\_10E\_C, TXP\_MR\_10E\_L, TXPP\_MR\_2.5G, ADM-10G, or OTU2\_XP card at each end of the optical span.



### Note

For general information about MXP and TXP cards, refer to the “Card Reference” chapter in the *Cisco ONS 15454 DWDM Reference Manual*. For information about provisioning them, refer to the “Provision Transponder and Muxponder Cards” chapter in the *Cisco ONS 15454 DWDM Procedure Guide*.

## Clear the PTIM Alarm

- Step 1** In node view (single-shelf mode) or shelf view (multishelf mode), double-click the alarmed MXP\_2.5G\_10G, TXP\_MR\_10G, TXP\_MR\_2.5G, TXP\_MR\_10E, TXP\_MR\_10E\_C, TXP\_MR\_10E\_L, or TXPP\_MR\_2.5G, ADM-10G, or OTU2\_XP card to open the card view.
- Step 2** Click the **Provisioning > OTN > OTN Lines** tabs.
- Step 3** Ensure that the G.709 OTN check box is checked. If not, check it and click **Apply**.
- Step 4** If the alarm does not clear, log into the Technical Support Website at <http://www.cisco.com/techsupport> for more information or call Cisco TAC (1-800-553-2447).

## 2.5.245 PWR-FAIL-A

Default Severity: Minor (MN), Non-Service-Affecting (NSA)

Logical Object: EQPT



The Equipment Power Failure at Connector A alarm occurs when there is no power supply from the main power connector to the equipment. This alarm occurs on the electrical interface assemblies (EIA), TCC2/TCC2P, or I/O cards.



**Warning**

**The power supply circuitry for the equipment can constitute an energy hazard. Before you install or replace the equipment, remove all jewelry (including rings, necklaces, and watches). Metal objects can come into contact with exposed power supply wiring or circuitry inside the DSLAM equipment. This could cause the metal objects to heat up and cause serious burns or weld the metal object to the equipment.** Statement 207

## Clear the PWR-FAIL-A Alarm

- Step 1** If a single card has reported the alarm, take the following actions depending on the reporting card:
- If the reporting card is an active traffic line port in a 1+1 protection group or part of a path protection configuration, ensure that an APS traffic switch has occurred to move traffic to the protect port.
-  **Note** Removing a card that currently carries traffic on one or more ports can cause a traffic hit. To avoid this, perform an external switch if a switch has not already occurred. See the [“2.8.2 Protection Switching, Lock Initiation, and Clearing”](#) section on page 2-237 for commonly used traffic-switching procedures.
- If the alarm is reported against a TCC2/TCC2P card, complete the [“Reset an Active TCC2/TCC2P Card and Activate the Standby Card”](#) procedure on page 2-241.
  - If the alarm is reported against an OC-N/STM-N card, complete the [“Reset a Card in CTC”](#) procedure on page 2-241.
- Step 2** If the alarm does not clear, complete the [“Remove and Reinsert \(Reseat\) Any Card”](#) procedure on page 2-243.
- Step 3** If the alarm does not clear, complete the [“Physically Replace a Card”](#) procedure on page 2-244 for the reporting card.
- Step 4** If the single card replacement does not clear the alarm, or if multiple cards report the alarm, verify the office power. Refer to the [“Install the Shelf and Common Control Cards”](#) chapter in the *Cisco ONS 15454 DWDM Procedure Guide* for procedures. See the [“1.10 Power Supply Problems”](#) section on page 1-59 as necessary.
- Step 5** If the alarm does not clear, reseal the power cable connection to the connector.
- Step 6** If the alarm does not clear, physically replace the power cable connection to the connector.
- Step 7** If the alarm does not clear, log into the Technical Support Website at <http://www.cisco.com/techsupport> for more information or call Cisco TAC (1-800-553-2447).

## 2.5.246 PWR-FAIL-B

Default Severity: Minor (MN), Non-Service-Affecting (NSA)

Logical Object: EQPT

The Equipment Power Failure at Connector B alarm occurs when there is no power supply from the main power connector to the equipment. This alarm occurs on the electrical interface assemblies (EIA), TCC2/TCC2P, or I/O cards.



**Warning**

**The power supply circuitry for the equipment can constitute an energy hazard. Before you install or replace the equipment, remove all jewelry (including rings, necklaces, and watches). Metal objects can come into contact with exposed power supply wiring or circuitry inside the DSLAM equipment. This could cause the metal objects to heat up and cause serious burns or weld the metal object to the equipment.** Statement 207

## Clear the PWR-FAIL-B Alarm

- 
- Step 1** Complete the [“Clear the PWR-FAIL-A Alarm” procedure on page 2-193](#).
- Step 2** If the alarm does not clear, log into the Technical Support Website at <http://www.cisco.com/techsupport> for more information or call Cisco TAC (1-800-553-2447).
- 

## 2.5.247 PWR-FAIL-RET-A

Default Severity: Minor (MN), Non-Service-Affecting (NSA)

Logical Object: EQPT

The Equipment Power Failure at Connector A alarm occurs when there is no power supplied to the backup power connector on the shelf. This alarm occurs on the electrical interface assemblies (EIA) or TCC2/TCC2P.

### Clear the PWR-FAIL-RET-A Alarm

- 
- Step 1** Complete the [“Clear the PWR-FAIL-A Alarm” procedure on page 2-193](#).
- Step 2** If the alarm does not clear, log into the Technical Support Website at <http://www.cisco.com/techsupport> for more information or call Cisco TAC (1-800-553-2447).
- 

## 2.5.248 PWR-FAIL-RET-B

Default Severity: Minor (MN), Non-Service-Affecting (NSA)

Logical Object: EQPT

The Equipment Power Failure at Connector B alarm occurs when there is no power supplied to the backup power connector on the shelf. This alarm occurs on the electrical interface assemblies (EIA) or TCC2/TCC2P.

## Clear the PWR-FAIL-RET-A Alarm

- 
- Step 1** Complete the “[Clear the PWR-FAIL-A Alarm](#)” procedure on page 2-193.
- Step 2** If the alarm does not clear, log into the Technical Support Website at <http://www.cisco.com/techsupport> for more information or call Cisco TAC (1-800-553-2447).
- 

## 2.5.249 PWR-PROT-ON

Default Severity: Major (MJ), Service-Affecting (SA)

SONET Logical Objects: OTS

The Raman Power Protection On alarm occurs only on the OPT-RAMP-C card when the Raman amplifier is used on fiber span that is too short for Raman power.

## Clear the PWR-PROT-ON Alarm

- 
- Step 1** To clear the alarm, check if the Raman amplifier is connected to the wrong span. If it is, check patch cords setup and fix it.
- Step 2** Alternatively, review the network configuration to see Raman amplifier has been wrongly used. If is, remove it.
- Step 3** If the condition does not clear, log into the Technical Support Website at <http://www.cisco.com/techsupport> for more information or call Cisco TAC (1-800-553-2447).
- 

## 2.5.250 RFI

Default Severity: Not Reported (NR), Non-Service-Affecting (NSA)

Logical Object: TRUNK

The Remote Failure Indication condition is raised against an MXP\_2.5G\_10G, TXP\_MR\_10G, TXP\_MR\_2.5G, TXP\_MR\_10E, TXP\_MR\_10E\_C, TXP\_MR\_10E\_L, TXPP\_MR\_2.5G, or ADM-10G card when the card has the “[AIS](#)” condition, page 2-26. The MXP or TXP cards only raise AIS (or remote failure indication [RFI]) when they are in line or section termination mode, that is, when the MXP or TXP cards in line termination mode or section termination mode have improperly terminated overhead bytes.

**Note**

---

For general information about MXP and TXP cards, refer to the “Card Reference” chapter in the *Cisco ONS 15454 DWDM Reference Manual*. For information about provisioning them, refer to the “Provision Transponder and Muxponder Cards” chapter in the *Cisco ONS 15454 DWDM Procedure Guide*.

---

## Clear the RFI Condition

- 
- Step 1** Complete the “[Delete a Circuit](#)” procedure on page 2-245 and then recreate the circuit.
- Step 2** If the condition does not clear, log into the Technical Support Website at <http://www.cisco.com/techsupport> for more information or call Cisco TAC (1-800-553-2447).
- 

### 2.5.251 RFI-L

Default Severity: Not Reported (NR), Non-Service-Affecting (NSA)

Logical Object: TRUNK

A RFI Line condition occurs when the ONS 15454 detects an RFI in OC-N card SONET overhead because of a fault in another node. Resolving the fault in the adjoining node clears the RFI-L condition in the reporting node. RFI-L indicates that the condition is occurring at the line level.

## Clear the RFI-L Condition

- 
- Step 1** Log into the node at the far-end node of the reporting ONS 15454.
- Step 2** Identify and clear any alarms, particularly the LOS (OCN) alarm.
- Step 3** If the condition does not clear, log into the Technical Support Website at <http://www.cisco.com/techsupport> for more information or call Cisco TAC (1-800-553-2447).
- 

### 2.5.252 RFI-P

Default Severity: Not Reported (NR), Non-Service-Affecting (NSA)

Logical Object: STSMON, STSTRM

The RFI Path condition occurs when the ONS 15454 detects an RFI in the an STS-1 signal SONET overhead because of a fault in another node. Resolving the fault in the adjoining node clears the RFI-P condition in the reporting node. RFI-P occurs in the terminating node in that path segment.

## Clear the RFI-P Condition

- 
- Step 1** Verify that the ports are enabled and in service (IS-NR or Unlocked,enabled) on the reporting ONS 15454:
- a. Confirm that the LED is correctly illuminated on the physical card.  
A green ACT/SBY LED indicates an active card. An amber ACT/SBY LED indicates a standby card.
  - b. To determine whether the OC-N port is in service, double-click the card in CTC to open the card view.
  - c. Click the **Provisioning > Line** tabs.
  - d. Verify that the Admin State column lists the port as IS or Unlocked.

- e. If the Admin State column lists the port as OOS,MT or Locked,maintenance or Locked,disabled, click the column and choose **IS or Unlocked**. Click **Apply**.



**Note** If ports managed into IS or Unlocked admin state are not receiving signals, the LOS alarm is either raised or remains, and the port service state transitions to OOS-AU,FLT.

- Step 2** To find the path and node failure, verify the integrity of the SONET STS circuit path at each of the intermediate SONET nodes.
- Step 3** Clear alarms in the node with the failure, especially the “[UNEQ-P](#)” alarm on page 2-226.
- Step 4** If the condition does not clear, log into the Technical Support Website at <http://www.cisco.com/techsupport> for more information or call Cisco TAC (1-800-553-2447).

## 2.5.253 RLS

Default Severity: Not Alarmed (NA), Non-Service-Affecting (NSA)

Logical Object: OTS

The Raman Laser Shutdown (RLS) condition is raised during the Raman link turn-up phase on RAMAN-TX port of the OPT-RAMP-C card when excessive back reflection is detected. When the RLS alarm is raised, the Raman pump laser inside the card is shut down automatically and the optical link turn-up procedure is terminated. The RLS condition must be cleared before proceeding with further provisioning.

### Clear the RLS Condition

- Step 1** Disconnect the LINE-RX port cable.
- Step 2** Clean the optical connectors. To do this, refer to the "Install Hardware" chapter in the *Cisco ONS 15454 Procedure Guide*.
- Step 3** Reconnect the LINE-RX port cable. Wait five minutes for the Raman link restart procedure to be completed on OPT-RAMP-C card.
- Step 4** If the RLS condition does not clear, replace the optical cable connected to the LINE-TX port. Repeat Step 3.
- Step 5** If the RLS condition persists, call the Cisco TAC (1 800 553-2447) to open a Return Material Authorization (RMA) case.

## 2.5.254 ROUTE-OVERFLOW

Default Severity: Minor (MN), Non-Service-Affecting (NSA)

Logical Object: NE regardless of MSTP or MSPP

The ROUTE-OVERFLOW indicates the condition when the OSPF routing table exceeds 700 routes. The symptoms for this condition are loss of visibility to a node or network, inability to access a node using CTC, CTM, Telnet, Ping, and so on.

## Clear the ROUTE-OVERFLOW Condition

**Step 1** Reconfigure the OSPF network to less than 700 routes.

### 2.5.255 RS-EOC

Default Severity: Minor (MN), Non-Service-Affecting (NSA)

Logical Object: TRUNK

The SONET Data Communications Channel (DCC) Termination Failure alarm occurs when the ONS 15454 loses its data communications channel. Although this alarm is primarily SONET, it can apply to DWDM. For example, the OSCM card can raise this alarm on its STM-1 section overhead.

The RS-DCC consists of three bytes, D1 through D3, in the SONET overhead. The bytes convey information about operation, administration, maintenance, and provisioning (OAM&P). The ONS 15454 uses the DCC on the SONET section overhead to communicate network management information.



**Warning**

**Class 1 laser product.** Statement 1008



**Warning**

**Class 1M laser radiation when open. Do not view directly with optical instruments.** Statement 1053



**Warning**

**On the OC192 LR/STM64 LH 1550 card, the laser is on when the card is booted and the safety key is in the on position (labeled 1). The port does not have to be in service for the laser to be on. The laser is off when the safety key is off (labeled 0).** Statement 293



**Warning**

**Invisible laser radiation could be emitted from the end of the unterminated fiber cable or connector. Do not stare into the beam directly with optical instruments. Viewing the laser output with certain optical instruments (for example, eye loupes, magnifiers, and microscopes) within a distance of 100 mm could pose an eye hazard.** Statement 1056



**Warning**

**Use of controls, adjustments, or performing procedures other than those specified could result in hazardous radiation exposure.** Statement 1057



**Note**

If a circuit shows an incomplete state when this alarm is raised, the logical circuit is in place. The circuit is able to carry traffic when the connection issue is resolved. You do not need to delete the circuit when troubleshooting this alarm.

## Clear the RS-EOC Alarm

- Step 1** If the alarm does not clear on the reporting node, verify the physical connections between the cards and that the fiber-optic cables are configured to carry RS-DCC traffic. If they are not, correct them. For more information about OC-N fiber connections and terminations, refer to the “Install Cards and Fiber-Optic Cable” chapter in the *Cisco ONS 15454 Procedure Guide*.



### Caution

Always use the supplied electrostatic discharge wristband when working with a powered ONS 15454. Plug the wristband cable into the ESD jack located lower-right edge of the shelf assembly.

If the physical connections are correct and configured to carry DCC traffic, ensure that both ends of the fiber span have unlocked ports. Verify that the ACT/SBY LED on each card is green.

- Step 2** When the LEDs on the cards are correctly illuminated, complete the [“Verify or Create Node RS-DCC Terminations” procedure on page 2-246](#) to verify that the DCC is provisioned for the ports at both ends of the fiber span.
- Step 3** Repeat [Step 2](#) at the adjacent nodes.
- Step 4** If DCC is provisioned for the ends of the span, verify that the port is active and in service by completing the following steps:
- Confirm that the card shows a green LED in CTC or on the physical card.  
A green ACT/SBY LED indicates an active card. An amber ACT/SBY LED indicates a standby card.
  - To determine whether the port is in service, double-click the card in CTC to display the card view.
  - For an OC-N card, click the **Provisioning > Line** tabs. For the OSCM card, click the **Provisioning > STM-1 Line** tabs.
  - Verify that the **Admin State** column lists the port as **IS or Unlocked**.
  - If the **Admin State** column lists the port as OOS,MT or Locked,maintenance or Locked,disabled, click the column and click **IS or Unlocked** from the drop-down list. Click **Apply**.



### Note

If a port in the unlocked admin state does not receive a signal, the LOS alarm is raised and the port service state transitions to Locked-disabled, automaticInService & failed.

- Step 5** For all nodes, if the card is in service, use an optical test set to determine whether signal failures are present on fiber terminations. For specific procedures to use the test set equipment, consult the manufacturer.



### Caution

Using an optical test set disrupts service on an OC-N card. It could be necessary to manually switch traffic carrying circuits over to a protection path. Refer to the [“2.8.2 Protection Switching, Lock Initiation, and Clearing” section on page 2-237](#) for commonly used switching procedures.

- Step 6** If no signal failures exist on terminations, measure power levels to verify that the budget loss is within the parameters of the receiver.
- Step 7** If budget loss is within parameters, ensure that fiber connectors are securely fastened and properly terminated. For more information refer to “Install Cards and Fiber-Optic Cables” chapter in the *Cisco ONS 15454 Procedure Guide*.

- Step 8** If fiber connectors are properly fastened and terminated, complete the [“Reset an Active TCC2/TCC2P Card and Activate the Standby Card” procedure on page 2-241](#).
- Wait ten minutes to verify that the card you reset completely reboots and becomes the standby card.
- Resetting the active TCC2/TCC2P card switches control to the standby TCC2/TCC2P card. If the alarm clears when the ONS 15454 node switches to the standby TCC2/TCC2P card, the user can assume that the previously active card is the cause of the alarm.
- Step 9** If the TCC2/TCC2P card reset does not clear the alarm, delete the problematic RS-DCC termination by completing the following steps:
- From card view, click **View > Go to Previous View** if you have not already done so.
  - Click the **Provisioning > Comm Channels > RS-DCC** tabs.
  - Highlight the problematic DCC termination.
  - Click **Delete**.
  - Click **Yes** in the Confirmation Dialog box.
- Step 10** Recreate the RS-DCC termination. Refer to the “Turn Up Network” chapter in the *Cisco ONS 15454 Procedure Guide* for procedures.
- Step 11** Verify that both ends of the DCC have been recreated at the optical ports.
- Step 12** If the alarm has not cleared, log into the Technical Support Website at <http://www.cisco.com/techsupport> for more information or log into <http://www.cisco.com/warp/public/687/Directory/DirTAC.shtml> to obtain a directory of toll-free Technical Support numbers for your country. If the Technical Support technician tells you to reseat the card, complete the [“Remove and Reinsert \(Reseat\) Any Card” procedure on page 2-243](#). If the Technical Support technician tells you to remove the card and reinstall a new one, follow the [“Physically Replace a Card” procedure on page 2-244](#).
- 

## 2.5.256 RS-TIM

Default Severity: Critical (CR), Service-Affecting (SA)

Logical Object: STMN

The Regenerator Section TIM alarm occurs when the expected J0 path trace string does not match the received string.

If the alarm occurs on a port that has been operating with no alarms, the circuit path has changed or someone entered a new incorrect value into the Current Transmit String field. Follow the procedure below to clear either instance.

### Clear the RS-TIM Alarm

- Step 1** Complete the [“Clear the TIM Alarm” procedure on page 2-222](#) for the J0 byte.
- Step 2** If the alarm does not clear, log into the Cisco Technical Support Website at <http://www.cisco.com/techsupport> for more information or log into <http://www.cisco.com/warp/public/687/Directory/DirTAC.shtml> to obtain a directory of toll-free Technical Support numbers for your country in order to report a Service-Affecting (SA) problem.
-



## 2.5.257 SD (TRUNK)

Default Severity: Not Alarmed (NA), Non-Service-Affecting (NSA)

Logical Object: TRUNK

A Signal Degrade (SD) condition on the trunk occurs when the quality of an optical signal to the MXP\_2.5G\_10G, TXP\_MR\_10G, TXP\_MR\_2.5G, TXP\_MR\_10E, TXP\_MR\_10E\_C, TXP\_MR\_10E\_L, TXPP\_MR\_2.5G, GE-XP, 10GE-XP, and ADM-10G card has BER on the incoming optical line that passes the signal degrade threshold. The alarm applies to the card ports and the trunk carrying optical or electrical signals to the card.

Signal degrade is defined by Telcordia as a soft failure condition. SD and SF both monitor the incoming BER and are similar, but SD is triggered at a lower BER than SF. The BER threshold on the ONS system is user-provisionable and has a range for SD from 1E-9 dBm to 1E-5 dBm.

**Note**

For more information about MXP and TXP cards and their thresholds, refer to the “Card Reference” chapter and the “Hardware Specifications” appendix respectively in the *Cisco ONS 15454 DWDM Reference Manual*.

### Clear the SD (TRUNK) Condition

- Step 1** Ensure that the fiber connector for the card is completely plugged in. For more information about fiber connections and card insertion, refer to the “Turn Up a Node” chapter in the *Cisco ONS 15454 DWDM Procedure Guide*.
- Step 2** If the BER threshold is correct and at the expected level, use an optical test set to measure the power level of the line to ensure it is within guidelines. For specific procedures to use the test set equipment, consult the manufacturer.
- Step 3** If the optical power level is good, verify that optical receive levels are within the acceptable range.
- Step 4** If receive levels are good, clean the fibers at both ends according to site practice. If no site practice exists, complete the procedure in the “Maintain the Node” chapter in the *Cisco ONS 15454 DWDM Procedure Guide*.
- Step 5** If the condition does not clear, verify that single-mode fiber is used.
- Step 6** If the fiber is of the correct type, verify that a single-mode laser is used at the far-end node.
- Step 7** Clean the fiber connectors at both ends for a signal degrade according to site practice.
- Step 8** Verify that a single-mode laser is used at the far end.
- Step 9** If the problem does not clear, the transmitter at the other end of the optical line could be failing and require replacement. Refer to the “2.8.4 Physical Card Reseating, Resetting, and Replacement” section on page 2-242.
- Step 10** If the condition does not clear, log into the Technical Support Website at <http://www.cisco.com/techsupport> for more information or call Cisco TAC (1-800-553-2447).

## 2.5.258 SD-L

Default Severity: Not Alarmed (NA), Non-Service-Affecting (NSA)

Logical Object: STMN

An SD Line condition is similar to the “SD (TRUNK)” condition, page 2-201. It applies to the line level of the SONET signal and travels on the B2 byte of the SONET overhead.

An SD-L on an Ethernet or OC-N card does not cause a protection switch. If the alarm is reported on a card that has also undergone a protection switch, the SD BER count continues to accumulate. The condition is superseded by higher-priority alarms such as the LOF and LOS alarms.



**Note**

For more information about Ethernet cards, refer to the *Ethernet Card Software Feature and Configuration Guide for the Cisco ONS 15454, Cisco ONS 15454 SDH, and Cisco ONS 15327*.

## Clear the SD-L Condition

- 
- Step 1** Complete the “Clear the SD (TRUNK) Condition” procedure on page 2-201.
- Step 2** If the condition does not clear, log into the Technical Support Website at <http://www.cisco.com/techsupport> for more information or call Cisco TAC (1-800-553-2447).

## 2.5.259 SD-L (TRUNK)

Default Severity: Not Alarmed (NA), Non-Service-Affecting (NSA)

Logical Object: TRUNK

A Signal Degrade (SD) condition on the trunk occurs when the quality of an optical signal to the MXP\_2.5G\_10G, TXP\_MR\_10G, TXP\_MR\_2.5G, TXP\_MR\_10E, TXP\_MR\_10E\_C, TXP\_MR\_10E\_L, TXPP\_MR\_2.5G, GE-XP, 10GE-XP, and ADM-10G card has bit error rate (BER) on the incoming optical line that passes the signal degrade threshold. The alarm applies to the card ports and the trunk carrying optical or electrical signals to the card.

## Clear the SD-L (TRUNK) Condition

- 
- Step 1** Complete the “Clear the SD (TRUNK) Condition” procedure on page 2-201.
- Step 2** If the condition does not clear, log into the Technical Support Website at <http://www.cisco.com/techsupport> for more information or call Cisco TAC (1-800-553-2447).

## 2.5.260 SD-P

Default Severity: Not Alarmed (NA), Non-Service-Affecting (NSA)

Logical Object: STSMON, STSTRM

An SD Path condition is similar to the “SD (TRUNK)” condition, page 2-201, but it applies to the path (STS) layer of the SONET overhead. A path or STS-level SD alarm travels on the B3 byte of the SONET overhead.

For path protection protected circuits, the BER threshold is user-provisionable and has a range for SD from 1E-9 dBm to 1E-5 dBm. For BLSR 1+1 and unprotected circuits, the BER threshold value is not user-provisionable and the error rate is hard-coded to 1E-6 dBm.

On path protection configurations, an SD-P condition causes a switch from the working card to the protect card at the path (STS) level. On BLSR, 1+1, and on unprotected circuits, an SD-P condition does not cause switching.

The BER increase that causes the condition is sometimes caused by a physical fiber problem such as a poor fiber connection, a bend in the fiber that exceeds the permitted bend radius, or a bad fiber splice.

The SD clears when the BER level falls to one-tenth of the threshold level that triggered the alarm.

## Clear the SD-P Condition

- 
- Step 1** Complete the [“Clear the SD \(TRUNK\) Condition” procedure on page 2-201](#).
- Step 2** If the condition does not clear, log into the Technical Support Website at <http://www.cisco.com/techsupport> for more information or call Cisco TAC (1-800-553-2447).
- 

## 2.5.261 SDBER-EXCEED-HO

Default Severity: Not Alarmed (NA), Non-Service-Affecting (NSA)

Logical Object: VCMON-HP, VCTRM-HP

The Signal Degrade Threshold Exceeded for High Order condition indicates that the signal degrade BER threshold has been exceeded for a high-order (VC-4) path on optical (traffic) cards.

SDBER-EXCEED-HO occurs when the signal BER falls within the degrade threshold (typically 1E-7 dBm) set on the node.



---

**Class 1 laser product.** Statement 1008

---



---

**Class 1M laser radiation when open. Do not view directly with optical instruments.** Statement 1053

---



---

**Invisible laser radiation could be emitted from the end of the unterminated fiber cable or connector. Do not stare into the beam directly with optical instruments. Viewing the laser output with certain optical instruments (for example, eye loupes, magnifiers, and microscopes) within a distance of 100 mm could pose an eye hazard.** Statement 1056

---

## Clear the SDBER-EXCEED-HO Condition

- 
- Step 1** Determine the BER threshold. Complete the [“Clear an MXP, TXP, GE-XP, 10GE-XP, and ADM-10G Card Loopback Circuit” procedure on page 2-245](#).
- Step 2** If adjustment is acceptable in site practices, adjust the threshold.
- Using an optical test set, measure the input power level of the line and ensure that the level is within the guidelines. For specific procedures to use the test set equipment, consult the manufacturer.
- Step 3** Verify the input fiber cable connections to the reporting card.

- Step 4** Clean the input fiber cable ends according to site practice. If no site practice exists, complete the procedure in the “Maintain the Node” chapter of the *Cisco ONS 15454 Procedure Guide*.

If the condition does not clear, log into the Cisco Technical Support Website at <http://www.cisco.com/techsupport> for more information or log into <http://www.cisco.com/warp/public/687/Directory/DirTAC.shtml> to obtain a directory of toll-free Technical Support numbers for your country. If the condition applies to VCMON-HP, it is Service-Affecting (SA).

## 2.5.262 SF (TRUNK)

Default Severity: Not Alarmed (NA), Non-Service-Affecting (NSA)

Logical Object: TRUNK

A Signal Fail (SF) condition for the trunk occurs when the quality of an optical signal to the MXP\_2.5G\_10G, TXP\_MR\_10G, TXP\_MR\_2.5G, TXP\_MR\_10E, TXP\_MR\_10E\_C, TXP\_MR\_10E\_L, TXPP\_MR\_2.5G, GE-XP, 10GE-XP, or ADM-10G card has BER on the incoming optical line that passes the signal fail threshold. The alarm applies to the card ports and the trunk carrying optical or electrical signals to the card.

Signal fail is defined by Telcordia as a hard failure condition. SF monitors the incoming BER and is triggered when the BER surpasses the default range.



### Warning

**Invisible laser radiation could be emitted from the end of the unterminated fiber cable or connector. Do not stare into the beam directly with optical instruments. Viewing the laser output with certain optical instruments (for example, eye loupes, magnifiers, and microscopes) within a distance of 100 mm could pose an eye hazard.** Statement 1056



### Warning

**Use of controls, adjustments, or performing procedures other than those specified could result in hazardous radiation exposure.** Statement 1057



### Note

For more information about MXP and TXP cards and their thresholds, refer to the “Card Reference” chapter and the “Hardware Specifications” appendix respectively in the *Cisco ONS 15454 DWDM Reference Manual*.

## Clear the SF (TRUNK) Condition

- Step 1** Complete the “[Clear the SD \(TRUNK\) Condition](#)” procedure on page 2-201.



### Caution

Always use the supplied electrostatic discharge wristband when working with a powered ONS system. Plug the wristband cable into the ESD jack located on the lower-right edge of the shelf assembly.

- Step 2** If the condition does not clear, log into the Technical Support Website at <http://www.cisco.com/techsupport> for more information or call Cisco TAC (1-800-553-2447).
- 

## 2.5.263 SF-L

Default Severity: Not Alarmed (NA), Non-Service-Affecting (NSA)

Logical Object: EQPT

An SF Line condition is similar to the “[SD \(TRUNK\)](#)” condition, [page 2-201](#), but it applies to the line layer B2 overhead byte of the SONET signal. It can trigger a protection switch.

The SF-L condition clears when the BER level falls to one-tenth of the threshold level that triggered the condition. A BER increase is sometimes caused by a physical fiber problem, including a poor fiber connection, a bend in the fiber that exceeds the permitted bend radius, or a bad fiber splice.

The condition is superseded by higher-priority alarms such as the LOF and LOS alarms.

### Clear the SF-L Condition

---

- Step 1** Complete the “[Clear the SD \(TRUNK\) Condition](#)” procedure on [page 2-201](#).
- Step 2** If the condition does not clear, log into the Technical Support Website at <http://www.cisco.com/techsupport> for more information or call Cisco TAC (1-800-553-2447).

## 2.5.264 SF-L (TRUNK)

Default Severity: Not Alarmed (NA), Non-Service-Affecting (NSA)

Logical Object: TRUNK

A Signal Fail (SF) condition is raised on the trunk when the quality of an incoming optical signal to the MXP\_2.5G\_10G, TXP\_MR\_10G, TXP\_MR\_2.5G, TXP\_MR\_10E, TXP\_MR\_10E\_C, TXP\_MR\_10E\_L, TXPP\_MR\_2.5G, or ADM-10G card has high BER due to bent or degraded fiber connected to the trunk, on the incoming optical line that passes the signal fail threshold. The alarm applies to the card ports and the trunk carrying optical or electrical signals to the card.

The SF-L condition monitors the incoming BER and is triggered when the BER surpasses the default range.

### Clear the SF-L (TRUNK) Condition

---

- Step 1** Complete the “[Clear the SD \(TRUNK\) Condition](#)” procedure on [page 2-201](#).



**Caution**

Always use the supplied electrostatic discharge wristband when working with a powered ONS system. Plug the wristband cable into the ESD jack located on the lower-right edge of the shelf assembly. For detailed instructions on how to wear the ESD wristband, refer to the Cisco ONS Electrostatic Discharge and Grounding Guide.

---

- Step 2** If the condition does not clear, log into the Technical Support Website at <http://www.cisco.com/techsupport> for more information or call Cisco TAC (1-800-553-2447).

## 2.5.265 SF-P

Default Severity: Not Alarmed (NA), Non-Service-Affecting (NSA)

Logical Object: STSMON, STSTRM

An SF Path condition is similar to the “[SF \(TRUNK\) condition, page 2-204](#)”, but it applies to the path (STS) layer B3 byte of the SONET overhead. It can trigger a protection switch.

The SF-P condition clears when the BER level falls to one-tenth of the threshold level that triggered the condition. A BER increase is sometimes caused by a physical fiber problem, including a poor fiber connection, a bend in the fiber that exceeds the permitted bend radius, or a bad fiber splice.

### Clear the SF-P Condition

- 
- Step 1** Complete the “[Clear the SF \(TRUNK\) Condition](#)” procedure on page 2-204.
- Step 2** If the condition does not clear, log into the Technical Support Website at <http://www.cisco.com/techsupport> for more information or call Cisco TAC (1-800-553-2447).
- 

## 2.5.266 SFTWDOWN

Default Severity: Minor (MN), Non-Service-Affecting (NSA)

Logical Object: EQPT

A Software Download in Progress alarm occurs when the TCC2/TCC2P card is downloading or transferring software.

If the active and standby TCC2/TCC2P cards have the same versions of software, it takes approximately three minutes for software to be updated on a standby TCC2/TCC2P card.

If the active and standby TCC2/TCC2P cards have different software versions, the transfer can take up to 30 minutes. Software transfers occur when different software versions exist on the two cards. After the transfer completes, the active TCC2/TCC2P card reboots and goes into standby mode after approximately three minutes.

No action is necessary. Wait for the transfer or the software download to complete. If the alarm does not clear, log into the Technical Support Website at <http://www.cisco.com/techsupport> for more information or call Cisco TAC (1-800-553-2447).



**Note**

---

SFTWDOWN is an informational alarm.

---

## 2.5.267 SHELF-COMM-FAIL

Default Severity: Major (MJ), Service-Affecting (SA)

Logical Object: SHELF

The Shelf Communication Failure alarm applies to optical equipment when an NC shelf is unable to communicate with an SS shelf. Typically this occurs when there is a fiber disconnection. But the alarm can also occur if an SS shelf is resetting.

## Clear the SHELF-COMM-FAIL Alarm

- 
- Step 1** Determine whether an SS shelf controller is being reset. If it is being reset, you must wait for the shelf to reset for this alarm to clear.
  - Step 2** If the alarm does not clear or if no shelf is being reset, check the cabling between the TCC2/TCC2P and the MS-ISC card. Correct it if necessary.
  - Step 3** If the alarm does not clear, log into the Technical Support Website at <http://www.cisco.com/techsupport> for more information or call Cisco TAC (1-800-553-2447) to report a Service-Affecting (SA) problem.
- 

## 2.5.268 SH-IL-VAR-DEG-HIGH

Default Severity: Minor (MN), Non-Service-Affecting (NSA)

Logical Object: OTS

The Switch Insertion Loss Variation Degrade High alarm occurs as the OSC-CSM card optical switch ages and slowly increases its insertion loss. This alarm indicates that the insertion loss has crossed the high degrade threshold. The card must eventually be replaced.



**Note** For more information about insertion loss, refer to the APC section of the “Network Reference” chapter of the *Cisco ONS 15454 DWDM Reference Manual*.

---

## Clear the SH-IL-VAR-DEG-HIGH Alarm

- 
- Step 1** For the alarmed card, complete the “[Physically Replace a Card](#)” procedure on page 2-244 as appropriate.
  - Step 2** If the alarm does not clear, log into the Technical Support Website at <http://www.cisco.com/techsupport> for more information or call Cisco TAC (1-800-553-2447).
- 

## 2.5.269 SH-IL-VAR-DEG-LOW

Default Severity: Minor (MN), Non-Service-Affecting (NSA)

Logical Object: OTS

The Switch Insertion Loss Variation Degrade Low alarm occurs as the OSC-CSM card optical switch ages and slowly decreases its insertion loss. This alarm indicates that the insertion loss has crossed the low degrade threshold. The card must eventually be replaced.

**Note**

For more information about insertion loss, refer to the APC section in the “Network Reference” chapter of the *Cisco ONS 15454 DWDM Reference Manual*.

## Clear the SH-IL-VAR-DEG-LOW Alarm

- 
- Step 1** For the alarmed card, complete the “[Physically Replace a Card](#)” procedure on page 2-244 as appropriate.
- Step 2** If the alarm does not clear, log into the Technical Support Website at <http://www.cisco.com/techsupport> for more information or call Cisco TAC (1-800-553-2447).
- 

## 2.5.270 SHUTTER-OPEN

Default Severity: Not Alarmed (NA), Non-Service-Affecting (NSA)

Logical Object: OTS

The SHUTTER-OPEN condition occurs if an OSC-CSM card laser shutter remains open after the “[LOS \(OTS\)](#)” alarm on page 2-136 is detected. A laser shutter remains open if an optical safety issue is present and closes when the OSC-CSM card LINE-RX port receives OSC power for three consecutive seconds.

### Clear the SHUTTER-OPEN Condition

- 
- Step 1** Complete the “[Clear the LOS \(OTS\) Alarm](#)” procedure on page 2-136.
- Step 2** If the SHUTTER-OPEN condition still does not clear, it indicates that the unit shutter is not working properly. Complete the “[Physically Replace a Card](#)” procedure on page 2-244.
- Step 3** If the condition does not clear, log into the Technical Support Website at <http://www.cisco.com/techsupport> for more information or call Cisco TAC (1-800-553-2447).
- 

## 2.5.271 SIGLOSS

Default Severity: Major (MJ), Service-Affecting (SA)

Logical Objects: FC, GE, ISC, TRUNK

The Signal Loss on Data Interface alarm is raised on XP and MXP cards FC and ISC client data ports when there is a loss of signal. (Loss of Gigabit Ethernet client signal results in a CARLOSS [GE], not SIGLOSS.) SIGLOSS can also be raised on the XP and MXP trunk port.

The Signal Loss on Data Interface alarm is raised on OTU2\_XP card 10GE and 10G FC client data ports when there is a loss of signal.

If the SYNCLOSS alarm was previously raised on the port, the SIGLOSS alarm will demote it.



## Clear the SIGLOSS Alarm

- 
- Step 1** Ensure that the port connection at the near end of the SONET or SDH (ETSI) link is operational.
  - Step 2** Verify fiber continuity to the port. To verify fiber continuity, follow site practices.
  - Step 3** Check the physical port LED on the card. The port LED looks clear (that is, not lit green) if the link is not connected.
  - Step 4** If the alarm does not clear, log onto <http://www.cisco.com/techsupport> for more information or call Cisco TAC (1-800-553-2447) in order to report a Service-Affecting (SA) problem.
- 

## 2.5.272 SNTP-HOST

Default Severity: Minor (MN), Non-Service-Affecting (NSA)

Logical Object: NE

The Simple Network Timing Protocol (SNTP) Host Failure alarm indicates that an ONS system serving as an IP proxy for the other ONS system nodes in the ring is not forwarding SNTP information to the other nodes in the network. The forwarding failure can result from two causes: either the IP network attached to the ONS system proxy node is experiencing problems, or the ONS system proxy node itself is not functioning properly.

## Clear the SNTP-HOST Alarm

- 
- Step 1** Ping the SNTP host from a workstation in the same subnet to ensure that communication is possible within the subnet by completing the [“1.6.8 Verify PC Connection to the ONS 15454 \(ping\)” procedure on page 1-42](#).
  - Step 2** If the ping fails, contact the network administrator who manages the IP network that supplies the SNTP information to the proxy and determine whether the network is experiencing problems, which could affect the SNTP server/router connecting to the proxy ONS system.
  - Step 3** If no network problems exist, ensure that the ONS system proxy is provisioned correctly:
    - a. In node view (single-shelf mode) or shelf view (multishelf mode), for the ONS system serving as the proxy, click the **Provisioning > General > General** tabs.
    - b. Ensure that the Use NTP/SNTP Server check box is checked.
    - c. If the Use NTP/SNTP Server check box is not checked, click it.
    - d. Ensure that the Use NTP/SNTP Server field contains a valid IP address for the server.
  - Step 4** If proxy is correctly provisioned, refer to the “Timing” chapter in the *Cisco ONS 15454 Reference Manual* for more information on SNTP Host.
  - Step 5** If the alarm does not clear, log into the Technical Support Website at <http://www.cisco.com/techsupport> for more information or call Cisco TAC (1-800-553-2447).
-

## 2.5.273 SPANLEN-OUT-OF-RANGE

Default Severity: Minor (MN), Non-Service-Affecting (NSA)

Logical Object: OTS

The SPANLEN-OUT-OF-RANGE alarm is raised when span loss measured by CTC is higher than the maximum expected span loss (or lower than the minimum expected span loss).

The TCC2/TCC2P automatically measures span loss every hour, or it calculates it when you perform the “Calculate Span Loss” operation. (For procedures to perform this operation, refer to the “Manage the Node” chapter in the *Cisco ONS 15454 DWDM Procedure Guide*.)

To create its span calculation, CTC compares far-end POSC power with the near-end OSC power to create the span length measurement. The loss is recalculated in each MSTP node, since the OSC channel is regenerated in each MSTP node.

### Clear the SPANLEN-OUT-OF-RANGE Alarm

---

**Step 1** Determine the maximum and minimum expected span loss values provided by Cisco TransportPlanner and confirm that they are correctly entered in CTC.

**Step 2** Determine whether the measured span length falls between these two values.



---

**Note** Cisco TransportPlanner determines the span length range according to span length and allocated margins. If this value is set to zero in CTC, the SPANLEN-OUT-OF-RANGE alarm is never raised.

---

**Step 3** If the value falls outside this range, check the following factors in the fiberling:

- Clearance
- Integrity
- Connection

**Step 4** Determine whether any site variations are present which conflict with the Cisco TransportPlanner design and correct them.

**Step 5** If the alarm does not clear, log into the Technical Support Website at <http://www.cisco.com/techsupport> for more information or call Cisco TAC (1-800-553-2447).

---

## 2.5.274 SPAN-NOT-MEASURED

SPAN-NOT-MEASURED is a transient condition. For more information about it, refer to [Chapter 3](#), “Transient Conditions.”

## 2.5.275 SQUELCHED

Default Severity: Not Alarmed (NA), Non-Service-Affecting (NSA)

Logical Objects: 2R, ESCON, FC, GE, ISC, OCN/STMN, TRUNK

The Client Signal Squelched condition is raised by a TXP\_MR\_10G, TXP\_MR\_10E, TXP\_MR\_10E\_C, TXP\_MR\_10E\_L, TXP\_MR\_2.5G, TXPP\_MR\_2.5G, MXP\_2.5G\_10G, MXP\_2.5G\_10E, MXP\_2.5G\_10E\_C, MXP\_2.5G\_10E\_L, MXP\_MR\_2.5G, MXPP\_MR\_2.5G, GE-XP, 10GE-XP, ADM-10G, and OTU2\_XP card.

The condition can be raised in the following situations:

- An MXP or TXP client facility detects that an upstream receive facility has experienced a loss of signal (such as an Ethernet CARLOSS, DWDM SIGLOSS, or optical LOS). In response, the facility's transmit is turned off (SQUELCHED). The upstream receive facilities are the trunk receive on the same card as the client, as well as the client receive on the card at the other end of the trunk span.
- The client will squelch if the upstream trunk receive (on the same card) experiences a SIGLOSS, Ethernet CARLOSS, LOS, or LOS (TRUNK) alarm. In some transparent modes, the client is squelched if the trunk detects an AIS condition or a TIM alarm.
- The client will squelch if the upstream client receive (on the card at the other end of the DWDM span) experiences CARLOSS, SIGLOSS, or LOS.

In an example situation, an upstream MXP\_2.5G\_10G client port receive experiences a "loss of light," and this port raises CARLOSS, SIGLOSS, or LOS (determined by the payload type) locally.

The local client raises SQUELCHED if it also raises one of the following alarms for the client, all of which are signalled by the upstream node:

- [2.5.211 ODUK-1-AIS-PM, page 2-167](#)
- [2.5.212 ODUK-2-AIS-PM, page 2-168](#)
- [2.5.213 ODUK-3-AIS-PM, page 2-168](#)
- [2.5.214 ODUK-4-AIS-PM, page 2-169](#)

On the MXP\_MR\_10G, the local client raises a SQUELCHED condition if the upstream client detects one of the following alarms. Note that no corresponding local alarm is raised to indicate which of these conditions is present upstream.

- LOS for the clients including the "LOS (2R)" alarm on page 2-133, the "LOS (ESCON)" alarm on page 2-134, and the "LOS (ISC)" alarm on page 2-135
- CARLOSS for the clients including the "CARLOSS (FC)" alarm on page 2-53, the "CARLOSS (GE)" alarm on page 2-53, and the "CARLOSS (ISC)" alarm on page 2-54

The local client raises a SQUELCHED condition if the local trunk raises one of the following alarms:

- [2.5.232 OTUK-LOF, page 2-181](#)
- [2.5.229 OTUK-AIS, page 2-179](#)
- [2.5.166 LOS \(TRUNK\), page 2-136](#)
- [2.5.235 OTUK-TIM, page 2-184](#) (squelching enabled)
- [2.5.215 ODUK-AIS-PM, page 2-169](#)
- [2.5.217 ODUK-LCK-PM, page 2-170](#)
- [2.5.221 ODUK-TIM-PM, page 2-173](#) (squelching enabled)
- [2.5.301 TIM, page 2-222](#) (for the OCN/STMN, squelching enabled)
- LOF (OCN/STMN) alarm in the "Alarm Troubleshooting" chapter of the *Cisco ONS 15454 Troubleshooting Guide* or *Cisco ONS 15454SDH Troubleshooting Guide*
- LOS (OCN/STMN) alarm in the "Alarm Troubleshooting" chapter of the *Cisco ONS 15454 Troubleshooting Guide* or *Cisco ONS 15454SDH Troubleshooting Guide*

- 2.5.48 CARLOSS (TRUNK), page 2-55
- 2.5.322 WVL-MISMATCH, page 2-233 (client or trunk)

When troubleshooting the SQUELCHED condition locally, look for failures progressing upstream in the following order. (If you are troubleshooting this alarm remotely, reverse the order of progress.)

- Local client alarms, as previously listed
- Local trunk alarms, as previously listed
- Remote (upstream) client receive alarms, as previously listed

**Note**

If you see a SQUELCHED condition on the trunk, this can only be caused by a transponder (TXP) card.

## Clear the SQUELCHED Condition

- 
- Step 1** If the object is reported against any object besides ESCON, determine whether the remote node and local node reports and LOF or the LOS alarm (for the client trunk, as listed here). If it does, turn to the relevant section in this chapter and complete the troubleshooting procedure.
- Step 2** If no LOF or LOS is reported, determine whether any other listed remote node or local node conditions as listed here have occurred. If so, turn to the relevant section of this chapter and complete the troubleshooting procedure.
- Step 3** If none of these alarms is reported, determine whether the local port reporting the SQUELCHED condition is in loopback. (You will see LPBKFACILITY OR LPBKTERMINAL in the condition window for this port.) If it is in loopback, complete the following steps:
- In node view (single-shelf mode) or shelf view (multishelf mode), double-click the client card to open the card view.
  - Click the **Maintenance > Loopback > Port** tabs.
  - If the port Admin State column says OOS,MT (or Locked,maintenance) or OOS,DSBLD (or Locked,disabled), click the cell to highlight it and choose **IS**, or **Unlocked**, from the drop-down list. Changing the state to IS (or Unlocked) also clears any loopback provisioned on the port.
- Step 4** If the condition does not clear, log into the Technical Support Website at <http://www.cisco.com/techsupport> for more information or call Cisco TAC (1-800-553-2447).
- 

## 2.5.276 SSM-DUS

Default Severity: Not Alarmed (NA), Non-Service-Affecting (NSA)

Logical Object: TRUNK

The Synchronization Status (SSM) Message Quality Changed to Do Not Use (DUS) condition occurs on ADM-10G and MXP trunk ports when the synchronization status message (SSM) quality level degrades to DUS or is manually changed to DUS.

The signal is often manually changed to DUS to prevent timing loops from occurring. Sending a DUS prevents the timing from being reused in a loop. The DUS signal can also be sent for line maintenance testing.

**Note**

---

SSM-DUS is an informational condition and does not require troubleshooting.

---

## 2.5.277 SSM-FAIL

Single Failure Default Severity: Minor (MN), Non-Service-Affecting (NSA); Double Failure Default Severity: Major (MJ), Service-Affecting (SA)

Logical Object: TRUNK

The SSM Failed alarm occurs on ADM-10G and MXP trunk ports when the synchronization status messaging received by the system fails. The problem is external to the ONS system. This alarm indicates that although the ONS system is set up to receive SSM, the timing source is not delivering valid SSM messages.

### Clear the SSM-FAIL Alarm

- 
- Step 1** Verify that SSM is enabled on the external timing source.
- Step 2** If timing is enabled, use an optical test set to determine that the external timing source is delivering SSM. For specific procedures to use the test set equipment, consult the manufacturer.
- Step 3** If the alarm does not clear, log into the Technical Support Website at <http://www.cisco.com/techsupport> for more information or call Cisco TAC (1-800-553-2447).
- 

## 2.5.278 SSM-LNC

Default Severity: Not Alarmed (NA), Non-Service-Affecting (NSA)

Logical Object: TRUNK

The SSM Local Node Clock (LNC) Traceable condition occurs on ADM-10G and MXP trunk ports when the SSM (S1) byte of the SONET overhead multiplexing section has been changed to signify that the line or BITS timing source is the LNC.

**Note**

---

SSM-LNC is an informational condition and does not require troubleshooting.

---

## 2.5.279 SSM-OFF

Default Severity: Not Alarmed (NA), Non-Service-Affecting (NSA)

Logical Object: TRUNK

The SSM Off condition applies to references used for timing related to the ADM-10G and MXP trunk ports. It occurs when the SSM for the reference has been turned off. The node is set up to receive SSM, but the timing source is not delivering SSM messages.

## Clear the SSM-OFF Condition

- 
- Step 1** Complete the “[Clear the SSM-FAIL Alarm](#)” procedure on page 2-213.
- Step 2** If the condition does not clear, log into the Technical Support Website at <http://www.cisco.com/techsupport> for more information or call Cisco TAC (1-800-553-2447).
- 

### 2.5.280 SSM-PRC

Default Severity: Not Alarmed (NA), Non-Service-Affecting (NSA)

Logical Object: TRUNK

The SSM Primary Reference Clock (PRC) Traceable condition occurs when the SONET transmission level for ADM-10G and MXP trunk ports is PRC.



---

**Note** SSM-PRC is an informational condition and does not require troubleshooting.

---

### 2.5.281 SSM-PRS

Default Severity: Not Alarmed (NA), Non-Service-Affecting (NSA)

Logical Object: TRUNK

The SSM Primary Reference Source (PRS) Traceable condition occurs when the SSM transmission level for ADM-10G and MXP trunk ports is Stratum 1 Traceable.



---

**Note** SSM-PRS is an informational condition and does not require troubleshooting.

---

### 2.5.282 SSM-RES

Default Severity: Not Alarmed (NA), Non-Service-Affecting (NSA)

Logical Object: TRUNK

The SSM Reserved (RES) For Network Synchronization Use condition occurs when the synchronization message quality level for ADM-10G and MXP trunk ports is RES.



---

**Note** SSM-RES is an informational condition and does not require troubleshooting.

---

### 2.5.283 SSM-SMC

Default Severity: Not Alarmed (NA), Non-Service-Affecting (NSA)

Logical Object: TRUNK

The SSM SONET Minimum Clock (SMC) Traceable condition occurs when the synchronization message quality level for ADM-10G and MXP trunk ports is SMC. The login node does not use the clock because the node cannot use any reference beneath its internal level, which is ST3.

**Note**

---

SSM-SMC is an informational condition and does not require troubleshooting.

---

## 2.5.284 SSM-ST2

Default Severity: Not Alarmed (NA), Non-Service-Affecting (NSA)

Logical Object: TRUNK

The SSM Stratum 2 (ST2) Traceable condition occurs when the synchronization message quality level for ADM-10G and MXP trunk ports is ST2.

**Note**

---

SSM-ST2 is an informational condition and does not require troubleshooting.

---

## 2.5.285 SSM-ST3

Default Severity: Not Alarmed (NA), Non-Service-Affecting (NSA)

Logical Object: TRUNK

The SSM Stratum 3 (ST3) Traceable condition occurs when the synchronization message quality level for ADM-10G and MXP trunk ports is ST3.

**Note**

---

SSM-ST3 is an informational condition and does not require troubleshooting.

---

## 2.5.286 SSM-ST3E

Default Severity: Not Alarmed (NA), Non-Service-Affecting (NSA)

Logical Object: TRUNK

The SSM Stratum 3E (ST3E) Traceable condition indicates that the synchronization message quality level for ADM-10G and MXP trunk ports is ST3E. SSM-ST3E is a Generation 2 SSM and is used for Generation 1.

**Note**

---

SSM-ST3E is an informational condition and does not require troubleshooting.

---

## 2.5.287 SSM-ST4

Default Severity: Not Alarmed (NA), Non-Service-Affecting (NSA)

Logical Object: TRUNK

The SSM Stratum 4 (ST4) Traceable condition occurs when the synchronization message quality level is ST4 for ADM-10G and MXP trunk ports. The message quality is not used because it is below ST3.

**Note**

---

SSM-ST4 is an informational condition and does not require troubleshooting.

---

## 2.5.288 SSM-STU

Default Severity: Not Alarmed (NA), Non-Service-Affecting (NSA)

Logical Object: TRUNK

The SSM Synchronization Traceability Unknown (STU) condition occurs when the reporting node is timed to a reference that does not support SSM, but the ONS system has SSM support enabled (for the ADM-10G and MXP trunk ports). SSM-STU can also occur if the timing source is sending out SSM messages but SSM is not enabled on the ONS system.

### Clear the SSM-STU Condition

- 
- Step 1** In node view (single-shelf mode) or shelf view (multishelf mode), click the **Provisioning > Timing > BITS Facilities** tabs.
- Step 2** Complete one of the following depending upon the status of the Sync Messaging Enabled check box:
- If the **Sync. Messaging Enabled** check box for the BITS source is checked, uncheck the box.
  - If the **Sync. Messaging Enabled** check box for the BITS source is not checked, check the box.
- Step 3** Click **Apply**.
- Step 4** If the condition does not clear, log into the Technical Support Website at <http://www.cisco.com/techsupport> for more information or call Cisco TAC (1-800-553-2447).
- 

## 2.5.289 SSM-TNC

Default Severity: Not Alarmed (NA), Non-Service-Affecting (NSA)

Logical Object: TRUNK

The SSM Transit Node Clock (TNC) Traceable condition occurs when the synchronization message quality level is TNC for ADM-10G and MXP trunk ports.

**Note**

---

SSM-TNC is an informational condition and does not require troubleshooting.

---

## 2.5.290 SW-MISMATCH

Default Severity: Not Alarmed (NA), Non-Service-Affecting (NSA)

Logical Object: EQPT

The Software Mismatch condition occurs during software upgrade when there is a mismatch between software versions. The card connecting to the TCC2/TCC2P card is running an older version than the TCC2/TCC2P card is.



## Clear the SW-MISMATCH Condition

- 
- Step 1** Complete the “[Reset a Card in CTC](#)” procedure on page 2-241 for the errored card.
- Step 2** If the condition does not clear, log into the Technical Support Website at <http://www.cisco.com/techsupport> for more information or call Cisco TAC (1-800-553-2447).
- 

## 2.5.291 SWTOPRI

Default Severity: Not Alarmed (NA), Non-Service-Affecting (NSA)

Logical Objects: EXT-SREF, NE-SREF

The Synchronization Switch to Primary Reference condition occurs when the ONS system switches to the primary timing source (reference 1). The ONS system uses three ranked timing references. The timing references are typically two BITS-level or line-level sources and an internal reference.



---

**Note** SWTOPRI is an informational condition and does not require troubleshooting.

---

## 2.5.292 SWTOSEC

Default Severity: Not Alarmed (NA), Non-Service-Affecting (NSA)

Logical Objects: EXT-SREF, NE-SREF

The Synchronization Switch to Secondary Reference condition occurs when the ONS system has switched to a secondary timing source (reference 2).

## Clear the SWTOSEC Condition

- 
- Step 1** To clear the condition, clear alarms related to failures of the primary source, such as the “[SYNCPRI](#)” alarm on page 2-219.
- Step 2** If the condition does not clear, log into the Technical Support Website at <http://www.cisco.com/techsupport> for more information or call Cisco TAC (1-800-553-2447).
- 

## 2.5.293 SWTOTHIRD

Default Severity: Not Alarmed (NA), Non-Service-Affecting (NSA)

Logical Objects: EXT-SREF, NE-SREF

The Synchronization Switch to Third Reference condition occurs when the ONS system has switched to a third timing source (reference 3).

## Clear the SWTOTHIRD Condition

- 
- Step 1** To clear the condition, clear alarms related to failures of the primary source, such as the “[SYNCPRI](#)” alarm on page 2-219 or the “[SYNCSEC](#)” alarm on page 2-220.
- Step 2** If the condition does not clear, log into the Technical Support Website at <http://www.cisco.com/techsupport> for more information or call Cisco TAC (1-800-553-2447).
- 

## 2.5.294 SYNC-FREQ

Default Severity: Not Alarmed (NA), Non-Service-Affecting (NSA)

Logical Object: TRUNK

The Synchronization Reference Frequency Out of Bounds condition is reported against any reference that is out of the bounds for valid references. The login node fails the reference and chooses another internal or external reference to use.

## Clear the SYNC-FREQ Condition

- 
- Step 1** Use an optical test set to verify the timing frequency of the line or BITS timing source and ensure that it falls within the proper frequency. For specific procedures to use the test set equipment, consult the manufacturer.
- For BITS, the proper timing frequency range is approximately –15 PPM to 15 PPM. For optical line timing, the proper frequency range is approximately –16 PPM to 16 PPM.
- Step 2** If the reference source frequency is not outside of bounds, complete the “[Physically Replace a Card](#)” procedure on page 2-244 for the TCC2/TCC2P card.



---

**Note** It takes up to 30 minutes for the TCC2/TCC2P card to transfer the system software to the newly installed TCC2/TCC2P card. Software transfer occurs in instances where different software versions exist on the two cards. When the transfer completes, the active TCC2/TCC2P card reboots and goes into standby mode after approximately three minutes.

---

- Step 3** If the SYNC-FREQ condition continues to report after replacing the TCC2/TCC2P card, log into the Technical Support Website at <http://www.cisco.com/techsupport> for more information or call Cisco TAC (1-800-553-2447).
- 

## 2.5.295 SYNCLOSS

Default Severity: Major (MJ), Service-Affecting (SA)

Logical Objects: FC, GE, ISC, TRUNK, EQPT

The Loss of Synchronization on Data Interface alarm is raised on MXP card client and trunk ports when there is a loss of signal synchronization on the port. The SYNCLOSS alarm is raised on OTU2\_XP card 10GE and 10G FC client data ports when there is a loss of signal synchronization on the port. This alarm is demoted by the SIGLOSS alarm.

## Clear the SYNCLOSS Alarm

- 
- Step 1** Ensure that the data port connection at the near end of the SONET or SDH (ETSI) link is operational.
- Step 2** Verify fiber continuity to the port. To do this, follow site practices.
- Step 3** View the physical port LED to determine whether the alarm has cleared.
- If the LED is green, the alarm has cleared.
  - If the port LED is clear (that is, not lit green), the link is not connected and the alarm has not cleared.
  - If the LED is red, this indicates that the fiber is pulled.
- Step 4** If the alarm does not clear, log into the Technical Support Website at <http://www.cisco.com/techsupport> for more information or call Cisco TAC (1-800-553-2447) to report a service-affecting problem.
- 

## 2.5.296 SYNCPRI

Default Severity:

Minor (MN), Non-Service-Affecting (NSA) for EXT-SREF; Major (MJ), Service-Affecting (SA) for NE-SREF (For SONET)

Minor (MN), Non-Service-Affecting (NSA) for EXT-SREF; Major (MJ), Non-Service-Affecting (NSA) for NE-SREF (For SDH)

Logical Objects: EXT-SREF, NE-SREF

A Loss of Timing on Primary Reference alarm occurs when the ONS system loses the primary timing source (reference 1). The ONS system uses three ranked timing references. The timing references are typically two BITS-level or line-level sources and an internal reference. If SYNCPRI occurs, the ONS system should switch to its secondary timing source (reference 2). Switching to the secondary timing source also triggers the “SWTOSEC” alarm, [page 2-217](#).

## Clear the SYNCPRI Alarm

- 
- Step 1** In node view (single-shelf mode) or shelf view (multishelf mode), click the **Provisioning > Timing > General** tabs.
- Step 2** Verify the current configuration for REF-1 of the NE Reference.
- Step 3** If the primary timing reference is a BITS input, complete the “[Clear the LOS \(BITS\) Alarm](#)” procedure on [page 2-134](#).
- Step 4** If the primary reference clock is an incoming port on the ONS system, complete the “Clear the LOS (OCN/STMN) Alarm” procedure located in the “Alarm Troubleshooting” chapter of the *Cisco ONS 15454 Troubleshooting Guide* or *Cisco ONS 15454SDH Troubleshooting Guide*.

- Step 5** If the condition does not clear, log into the Technical Support Website at <http://www.cisco.com/techsupport> for more information or call Cisco TAC (1-800-553-2447).
- 

## 2.5.297 SYNCSEC

Default Severity: Minor (MN), Non-Service-Affecting (NSA)

Logical Objects: EXT-SREF, NE-SREF

A Loss of Timing on Secondary Reference alarm occurs when the ONS system loses the secondary timing source (reference 2). If SYNCSEC occurs, the ONS system should switch to a third timing source (reference 3) to obtain valid timing for the ONS system. Switching to a third timing source also triggers the “[SWTOTHIRD](#)” alarm, [page 2-217](#).

### Clear the SYNCSEC Alarm

---

- Step 1** In node view (single-shelf mode) or shelf view (multishelf mode), click the **Provisioning > Timing > General** tabs.
- Step 2** Verify the current configuration of REF-2 for the NE Reference.
- Step 3** If the secondary reference is a BITS input, complete the “[Clear the LOS \(BITS\) Alarm](#)” procedure on [page 2-134](#).
- Step 4** Verify that the BITS clock is operating properly.
- Step 5** If the secondary timing source is an incoming port on the ONS system, complete the “Clear the LOS (OCN/STMN) Alarm” procedure located in the “Alarm Troubleshooting” chapter of the *Cisco ONS 15454 Troubleshooting Guide* or the *Cisco ONS 15454SDH Troubleshooting Guide*.
- Step 6** If the alarm does not clear, log into the Technical Support Website at <http://www.cisco.com/techsupport> for more information or call Cisco TAC (1-800-553-2447).
- 

## 2.5.298 SYNCTHIRD

Default Severity: Minor (MN), Non-Service-Affecting (NSA)

Logical Objects: EXT-SREF, NE-SREF

A Loss of Timing on Third Reference alarm occurs when the ONS system loses the third timing source (reference 3). If SYNCTHIRD occurs and the ONS system uses an internal reference for source three, the TCC2/TCC2P card could have failed. The ONS system often reports either the “[FRNGSYNC](#)” condition on [page 2-88](#) or the “[HLDOVRSYNC](#)” condition on [page 2-102](#) after a SYNCTHIRD alarm.

### Clear the SYNCTHIRD Alarm

---

- Step 1** In node view (single-shelf mode) or shelf view (multishelf mode), click the **Provisioning > Timing > General** tabs.

- Step 2** Verify that the current configuration of REF-3 for the NE Reference. For more information about references, refer to the “Timing” chapter in the *Cisco ONS 15454 Reference Manual*.
- Step 3** If the third timing source is a BITS input, complete the “[Clear the LOS \(BITS\) Alarm](#)” procedure on page 2-134.
- Step 4** If the third timing source is an incoming port on the ONS system, complete the “Clear the LOS (OCN/STMN) Alarm” procedure located in the “Alarm Troubleshooting” chapter of the *Cisco ONS 15454 Troubleshooting Guide* or the *Cisco ONS 15454SDH Troubleshooting Guide*.

**Caution**

Always use the supplied electrostatic discharge wristband when working with a powered ONS system. Plug the wristband cable into the ESD jack located on the lower-right edge of the shelf assembly.

- Step 5** If the third timing source uses the internal ONS system timing, complete the “[Reset an Active TCC2/TCC2P Card and Activate the Standby Card](#)” procedure on page 2-241.
- Wait ten minutes to verify that the card you reset completely reboots and becomes the standby card.
- Step 6** If the reset card has not rebooted successfully, or the alarm has not cleared, call Cisco TAC (1-800-553-2447). If the Cisco TAC technician tells you to reseat the card, complete the “[Remove and Reinsert \(Reseat\) the Standby TCC2/TCC2P Card](#)” procedure on page 2-242. If the Cisco TAC technician tells you to remove the card and reinstall a new one, follow the “[Physically Replace a Card](#)” procedure on page 2-244.

## 2.5.299 SYSBOOT

Default Severity: Major (MJ), Service-Affecting (SA)

Logical Object: NE

The System Reboot alarm indicates that new software is booting on the TCC2/TCC2P card. No action is required. The alarm clears when all cards finish rebooting the new software. The reboot takes up to 30 minutes.

If the alarm does not clear, log into the Technical Support Website at <http://www.cisco.com/techsupport> for more information or call Cisco TAC (1-800-553-2447) in order to report a Service-Affecting (SA) problem.

**Note**

SYSBOOT is an informational alarm. It only requires troubleshooting if it does not clear.

## 2.5.300 TEMP-MISM

Default Severity: Not Alarmed (NA), Non-Service-Affecting (NSA)

Logical Object: NE

Temperature Reading Mismatch Between Control Cards is raised when the temperature readings on the two TCC2/TCC2P cards are out of range of each other by more than some predefined difference (such as 5 degrees C). A message containing power monitoring and temperature information is exchanged between the two TCC2/TCC2P cards, allowing the values to be compared. The temperature of each TCC2/TCC2P card is read from a system variable.

This condition can be caused by a clogged fan filter or by fan tray stoppage.

## Clear the TEMP-MISM Condition

- 
- Step 1** Complete the “[Inspect, Clean, and Replace the Reusable Air Filter](#)” procedure on page 2-247.
  - Step 2** If the condition does not clear, complete the “[Remove and Reinsert a Fan-Tray Assembly](#)” procedure on page 2-248.
  - Step 3** If the alarm does not clear, log into the Technical Support Website at <http://www.cisco.com/techsupport> for more information or call Cisco TAC (1-800-553-2447).
- 

## 2.5.301 TIM

Default Severity: Critical (CR), Service-Affecting (SA)

Logical Object: TRUNK

The Section TIM alarm occurs when the expected J0 section trace string does not match the received section trace string. This occurs because the data being received is not correct, and the receiving port could not be connected to the correct transmitter port.

If the alarm occurs on a port that has been operating with no alarms, the circuit path has changed due to a fiber misconnection, a TL1 routing change, or to someone entering an incorrect value in the Current Transmit String field.

TIM occurs on a port that has previously been operating without alarms if someone switches optical fibers that connect the ports. TIM is usually accompanied by other alarms, such as the LOS (OCN/STMN) or UNEQ-P (or HP-UNEQ) alarms. (For instructions to clear these alarms, refer to the “Alarm Troubleshooting” chapter of the *Cisco ONS 15454 Troubleshooting Guide* and the *Cisco ONS 15454SDH Troubleshooting Guide*.) If these alarms accompany a TIM alarm, reattach or replace the original cables/fibers to clear the alarms. If a Transmit or Expected String was changed, restore the original string.

## Clear the TIM Alarm

- 
- Step 1** Ensure that the physical fibers are correctly configured and attached. To do this, consult site documents. For more information about cabling an ONS system DWDM node, refer to the “Turn Up a Node” chapter in the *Cisco ONS 15454 DWDM Procedure Guide*.
  - Step 2** If the alarm does not clear, you can compare the J0 expected and transmitted strings and, if necessary, change them:
    - a. Log into the circuit source node and click the **Circuits** tab.
    - b. Select the circuit reporting the condition, then click **Edit**.
    - c. In the Edit Circuit window, check the **Show Detailed Circuit Map** check box and click **Apply**.
    - d. On the detailed circuit map, right-click the source circuit port and choose **Edit J0 Path Trace (port)** from the shortcut menu.
    - e. Compare the Current Transmit String and the Current Expected String entries in the Edit J0 Path Trace dialog box.

- f. If the strings differ, correct the Transmit or Expected strings and click **Apply**.
- g. Click **Close**.

- Step 3** If the alarm does not clear, ensure that the signal has not been incorrectly routed. (Although the ONS system routes circuits automatically, the circuit route could have been changed using TL1.) If necessary, manually correct the routing using TL1. For instructions, refer to the *Cisco ONS SONET TLI Reference Guide* and the *Cisco ONS SONET TLI Command Guide*.
- Step 4** If the alarm does not clear, log into the Technical Support Website at <http://www.cisco.com/techsupport> for more information or call Cisco TAC (1-800-553-2447) in order to report a Service-Affecting (SA) problem if necessary.
- 

## 2.5.302 TIM-MON

Default Severity: Minor (MN), Non-Service-Affecting (NSA)

Logical Object: TRUNK

The TIM Section Monitor TIM alarm is similar to the “TIM” alarm on page 2-222, but it applies to TXP\_MR\_10G, TXP\_MR\_2.5G, TXPP\_MR\_2.5G, TXP\_MR\_10E, TXP\_MR\_10E\_C, TXP\_MR\_10E\_L, and MXP\_2.5G\_10G cards when they are configured in transparent mode. (In transparent termination mode, all SONET overhead bytes are passed through from client ports to the trunk ports or from trunk ports to client ports.)



**Note**

For general information about MXP and TXP cards, refer to the “Card Reference” chapter in the *Cisco ONS 15454 DWDM Reference Manual*. For information about provisioning them, refer to the “Provision Transponder and Muxponder Cards” chapter in the *Cisco ONS 15454 DWDM Procedure Guide*.

---

## Clear the TIM-MON Alarm

- Step 1** Complete the “Clear the TIM Alarm” procedure on page 2-222.
- Step 2** If the alarm does not clear, log into the Technical Support Website at <http://www.cisco.com/techsupport> for more information or call Cisco TAC (1-800-553-2447).
- 

## 2.5.303 TIM-P

Default Severity: Critical (CR), Service-Affecting (SA) for STSTRM; Default Severity: Minor (MN), Non-Service-Affecting (NSA) for STSMON

Logical Object: STSMON, STSTRM

The TIM Path alarm occurs when the expected path trace string does not match the received path trace string. Path Trace Mode must be set to Manual or Auto for the TIM-P alarm to occur.

In manual mode at the Path Trace window, the user types the expected string into the Current Expected String field for the receiving port. The string must match the string typed into the Transmit String field for the sending port. If these fields do not match, the login node raises the TIM-P alarm. In Auto mode

on the receiving port, the card sets the expected string to the value of the received string. If the alarm occurs on a port that has been operating with no alarms, the circuit path has changed or someone entered a new incorrect value into the Current Transmit String field. Complete the following procedure to clear either instance.

## Clear the TIM-P Alarm

- 
- Step 1** Complete the [“Clear the TIM Alarm” procedure on page 2-222](#). (The option will say “Edit J1 Path Trace” rather than “Edit J0 Path Trace.”)
- Step 2** If the alarm does not clear, log into the Technical Support Website at <http://www.cisco.com/techsupport> for more information or call Cisco TAC (1-800-553-2447). If the alarm applies to the STSTRM object, it is Service-Affecting (SA).
- 

## 2.5.304 TIM-S

Default Severity: Critical (CR), Service-Affecting (SA)

Logical Object: OCN

The TIM for Section Overhead alarm occurs when there is a mismatch between the expected and received J0 section overhead strings in either Manual or Auto mode.

In manual mode at the DS3/EC1-48 card Section Trace window, the user enters the expected string into the Current Expected String field for the receiving port. The string must match the string typed into the Transmit String field for the sending port. If these fields do not match, the login node raises the TIM-S alarm.

In Auto mode on the receiving port, the card sets the expected string to the value of the received string. If the alarm occurs on a port that has been operating with no alarms, the circuit path has changed or someone entered a new incorrect value into the Current Transmit String field. Complete the following procedure to clear either problem.

TIM-S also occurs on a port that has previously been operating without alarms if someone switches the cables or optical fibers that connect the ports. If TIM-S is enabled on the port, the [“AIS-L” alarm on page 2-27](#) can be raised downstream and the [“RFI-L” alarm on page 2-196](#) can be raised upstream.



**Note**

AIS-L and RFI-L are disabled or enabled in the **Provisioning > EC1 > Section Trace** tab **Disable AIS/RDI on TIM-S?** check box.

---

## Clear the TIM-S Alarm

- 
- Step 1** Double-click the DS3/EC1-48 card to open the card view.
- Step 2** Click the **Provisioning > EC1 > Section Trace** tabs.
- Step 3** Choose the port from the **Port** pull-down.
- Step 4** In the Expected area, enter the correct string into the **Current Expected String** field.
- Step 5** Click **Apply**.



- Step 6** If the alarm does not clear, log into the Technical Support Website at <http://www.cisco.com/techsupport> for more information or call Cisco TAC (1-800-553-2447). If the alarm applies to the STSTRM object, it is Service-Affecting (SA).
- 

## 2.5.305 TRAIL-SIGNAL-FAIL

Default Severity: Not Alarmed (NA), Non-Service-Affecting (NSA)

Logical Objects: OCH, TRUNK

The Trail Signal Fail condition is raised on a DWDM trunk port or OCH port to correlate with the “[LOS-P \(TRUNK\)](#)” alarm on page 2-145 when the trunk port’s administrative state is set to OOS,DSBLD (or Locked,disabled).

### Clear the TRAIL-SIGNAL-FAIL Condition

- Step 1** Switch the OCHNC administrative state of the errored OCH or trunk port to **IS** , or **Unlocked** .:
- Step 2** If the condition does not clear, log into the Technical Support Website at <http://www.cisco.com/techsupport> for more information or call Cisco TAC (1-800-553-2447).
- 

## 2.5.306 UNC-WORD

Default Severity: Not Alarmed (NA), Non-Service-Affecting (NSA)

Logical Object: TRUNK

The Uncorrected FEC Word condition indicates that the FEC capability could not sufficiently correct the frame.



**Note**

For general information about MXP and TXP cards, refer to the “Card Reference” chapter in the *Cisco ONS 15454 DWDM Reference Manual*. For information about provisioning them, refer to the “Provision Transponder and Muxponder Cards” chapter in the *Cisco ONS 15454 DWDM Procedure Guide*.

---

### Clear the UNC-WORD Condition

- Step 1** Ensure that the fiber connector for the card is completely plugged in. For more information about fiber connections and card insertion, refer to the “Turn Up a Node” chapter in the *Cisco ONS 15454 DWDM Procedure Guide*.
- Step 2** Ensure that the ports on the far end and near end nodes have the same port rates and FEC settings. For more information about port rates and FEC settings, refer to the “Provision Transponder and Muxponder Cards” chapter in the *Cisco ONS 15454 DWDM Procedure Guide*.

- Step 3** If the BER threshold is correct and at the expected level, use an optical test set to measure the power level of the line to ensure it is within guidelines. For specific procedures to use the test set equipment, consult the manufacturer.
- Step 4** If the optical power level is good, verify that optical receive levels are within the acceptable range.
- Step 5** If receive levels are good, clean the fibers at both ends according to site practice. If no site practice exists, complete the procedure in the “Maintain the Node” chapter in the *Cisco ONS 15454 DWDM Procedure Guide*.
- Step 6** If the condition does not clear, verify that single-mode fiber is used.
- Step 7** If the fiber is of the correct type, verify that a single-mode laser is used at the far-end node.
- Step 8** Clean the fiber connectors at both ends for a signal degrade according to site practice.
- Step 9** Verify that a single-mode laser is used at the far end.
- Step 10** If the problem does not clear, the transmitter at the other end of the optical line could be failing and require replacement. Refer to the “[2.8.4 Physical Card Reseating, Resetting, and Replacement](#)” section on page 2-242.
- Step 11** If the condition does not clear, log into the Technical Support Website at <http://www.cisco.com/techsupport> for more information or call Cisco TAC (1-800-553-2447).

## 2.5.307 UNEQ-P

Default Severity: Critical (CR), Service-Affecting (SA)

Logical Object: STSMON, STSTRM

An SLMF UNEQ Path alarm occurs when the path does not have a valid sender. The UNEQ-P indicator is carried in the C2 signal path byte in the SONET overhead. The source of the problem is the node that is transmitting the signal into the node reporting the UNEQ-P.

The alarm could result from a PARTIAL circuit or an empty VT tunnel. UNEQ-P occurs in the node that terminates a path.



### Note

If a newly created circuit has no signal, a UNEQ-P alarm is reported on the OC-N cards and the AIS-P condition is reported on the terminating cards. These alarms clear when the circuit carries a signal.

## Clear the UNEQ-P Alarm

- Step 1** In node view, choose **Go to Network View from the View menu**.
- Step 2** Right-click the alarm to display the Select Affected Circuits shortcut menu.
- Step 3** Click **Select Affected Circuits**.
- Step 4** When the affected circuits appear, look in the Type column for VTT, which indicates a VT tunnel circuit. A VT tunnel with no VTs assigned could be the cause of an UNEQ-P alarm.
- Step 5** If the Type column does not contain VTT, there are no VT tunnels connected with the alarm. Go to [Step 7](#).
- Step 6** If the Type column does contain VTT, attempt to delete these rows:



**Note** The node does not allow you to delete a valid VT tunnel or one with a valid VT circuit inside.

- a. Click the VT tunnel circuit row to highlight it. Complete the [“Delete a Circuit” procedure on page 2-245](#).
- b. If an error message dialog box appears, the VT tunnel is valid and not the cause of the alarm.
- c. If any other rows contain VTT, repeat [Step 6](#).

- Step 7** If all nodes in the ring appear in the CTC network view, determine whether the circuits are complete:
- a. Click the **Circuits** tab.
  - b. Verify that PARTIAL is not listed in the Status column of any circuits.
- Step 8** If you find circuits listed as PARTIAL, use an optical test set to verify that these circuits are not working circuits that continue to pass traffic. For specific procedures to use the test set equipment, consult the manufacturer.
- Step 9** If the PARTIAL circuits are not needed or are not passing traffic, delete the PARTIAL circuits. Complete the [“Delete a Circuit” procedure on page 2-245](#).
- Step 10** Recreate the circuit with the correct circuit size. Refer to the “Create Circuits and VT Tunnels” chapter in the *Cisco ONS 15454 Procedure Guide*.
- Step 11** Log back in and verify that all circuits terminating in the reporting card are active:
- a. Click the **Circuits** tab.
  - b. Verify that the **Status** column lists all circuits as active.
- Step 12** If the alarm does not clear, clean the far-end optical fiber according to site practice. If no site practice exists, complete the procedure in the “Maintain the Node” chapter of the *Cisco ONS 15454 Procedure Guide*.

**Warning**

**On the OC-192 card, the laser is on when the card is booted and the safety key is in the on position (labeled 1). The port does not have to be in service for the laser to be on. The laser is off when the safety key is off (labeled 0).** Statement 293

**Warning**

**Invisible laser radiation could be emitted from the end of the unterminated fiber cable or connector. Do not stare into the beam directly with optical instruments. Viewing the laser output with certain optical instruments (for example, eye loupes, magnifiers, and microscopes) within a distance of 100 mm could pose an eye hazard.** Statement 1056

**Warning**

**Use of controls, adjustments, or performing procedures other than those specified could result in hazardous radiation exposure.** Statement 1057

**Caution**

Always use the supplied electrostatic discharge wristband when working with a powered ONS 15454. Plug the wristband cable into the ESD jack located on the lower-right edge of the shelf assembly.

- Step 13** If the alarm does not clear, complete the [“Physically Replace a Card” procedure on page 2-244](#) for the OC-N and electrical cards.

- Step 14** If the alarm does not clear, log into the Technical Support Website at <http://www.cisco.com/techsupport> for more information or call Cisco TAC (1-800-553-2447) in order to report a Service-Affecting (SA) problem.
- 

## 2.5.308 UNQUAL-PPM

Default Severity: Not Reported (NR), Non-Service-Affecting (NSA)

Logical Objects: PPM

The Unqualified PPM Inserted condition occurs when a PPM with a nonqualified product ID is plugged into the card's port; that is, the PPM passes the security code check as a Cisco PPM but is not qualified for use on the particular card.

### Clear the UNQUAL-PPM Condition

- Step 1** Obtain the correct Cisco PPM and replace the existing PPM with the new one.
- Step 2** If the condition does not clear, log into the Technical Support Website at <http://www.cisco.com/techsupport> for more information or call Cisco TAC (1-800-553-2447).

## 2.5.309 UNREACHABLE-TARGET-POWER

Default Severity: Minor (MN), Non-Service-Affecting (NSA)

Logical Object: OCH

The Unreachable Port Target Power alarm occurs on WSS32 cards during startup as the card laser attains its correct power level. The condition disappears when the card successfully boots.



**Note**

Card power levels are listed in the "Hardware Specifications" appendix of the Cisco ONS 15454 DWDM Reference Manual.



**Note**

UNREACHABLE-TARGET-POWER is an informational condition. It only requires troubleshooting if it does not clear.

---

## 2.5.310 UT-COMM-FAIL

Default Severity: Major (MJ), Service-Affecting (SA)

Logical Object: TRUNK

The Universal Transponder (UT) Module Communication Failure alarm is raised on MXP\_2.5G\_10E and TXP\_MR\_10E cards when there is a universal transponder communication failure because the universal transponder (UT) has stopped responding to the TCC2/TCC2P card.

## Clear the UT-COMM-FAIL Alarm

- 
- Step 1** In node view (single-shelf mode) or shelf view (multishelf mode), double-click the card to open the card view.
- Step 2** Request a laser restart:
- Click the **Maintenance > ALS** tabs.
  - Check the **Request Laser Restart** check box.
  - Click **Apply**.
- Step 3** If the alarm does not clear, log into the Technical Support Website at <http://www.cisco.com/techsupport> for more information or call Cisco TAC (1-800-553-2447) in order to report a service-affecting problem.
- 

### 2.5.311 UT-FAIL

Default Severity: Major (MJ), Service-Affecting (SA)

Logical Object: TRUNK

The Universal Transponder Module Hardware Failure alarm is raised against MXP\_2.5G\_10E and TXP\_MR\_10E cards when a UT-COMM-FAIL alarm persists despite being reset.

## Clear the UT-FAIL Alarm

- 
- Step 1** Complete the “[Physically Replace a Card](#)” procedure on page 2-244 for the alarmed card.
- Step 2** If the alarm does not clear, log into the Technical Support Website at <http://www.cisco.com/techsupport> for more information or call Cisco TAC (1-800-553-2447) in order to report a service-affecting problem.
- 

### 2.5.312 VOA-DISABLED

Default Severity: Critical (CR), Service-Affecting (SA)

Logical Object: EQPT

The VOA Disabled alarm indicates that the VOA control loop is disabled due to excessive counter-propagation light. This alarm is raised when there is a mis-cabling of interface cards, that is, when the interface trunk TX port is connected to DMX drop-TX port through the patch-panel.

## Clear the VOA-DISABLED Condition

- 
- Step 1** To clear the alarm, check and ensure that the patchcords connection to and from the interfaces trunk ports are proper.
- Step 2** If the alarm does not clear, log into the Technical Support Website at <http://www.cisco.com/techsupport> for more information or call Cisco TAC (1 800 553-2447).
-

## 2.5.313 VOA-HDEG

Default Severity: Minor (MN), Non-Service-Affecting (NSA)

Logical Objects: AOTS, OCH, OMS, OTS

The VOA High Degrade alarm is raised on DWDM cards when an equipped VOA exceeds the setpoint due to an internal problem. The alarm indicates that the attenuation has crossed the high degrade threshold. The alarmed card should be replaced at the next opportunity.

**Note**

---

For more information about provisioning VOA setpoints, refer to the “Network Reference” chapter of the *Cisco ONS 15454 DWDM Reference Manual*. For general information about DWDM cards, refer to the “Card Reference” chapter in the same manual.

---

### Clear the VOA-HDEG Alarm

- 
- Step 1** Complete the “[Physically Replace a Card](#)” procedure on page 2-244 for the alarmed card.
- Step 2** If the alarm does not clear, log into the Technical Support Website at <http://www.cisco.com/techsupport> for more information or call Cisco TAC (1-800-553-2447).
- 

## 2.5.314 VOA-HFAIL

Default Severity: Critical (CR), Service-Affecting (SA)

Logical Objects: AOTS, OCH, OMS, OTS

The VOA High Fail alarm is raised on DWDM cards when an equipped VOA exceeds the setpoint due to an internal problem. The alarm indicates that the attenuation has crossed the high fail threshold. The card must be replaced.

**Note**

---

For more information about provisioning VOA setpoints, refer to the “Network Reference” chapter of the *Cisco ONS 15454 DWDM Reference Manual*. For general information about DWDM cards, refer to the “Card Reference” chapter in the same manual.

---

### Clear the VOA-HFAIL Alarm

- 
- Step 1** Complete the “[Physically Replace a Card](#)” procedure on page 2-244 for the alarmed card.
- Step 2** If the alarm does not clear, log into the Technical Support Website at <http://www.cisco.com/techsupport> for more information or call Cisco TAC (1-800-553-2447) in order to report a Service-Affecting (SA) problem.
-

## 2.5.315 VOA-LDEG

Default Severity: Minor (MN), Non-Service-Affecting (NSA)

Logical Objects: AOTS, OCH, OMS, OTS

The VOA Low Degrade alarm is raised on DWDM cards when an equipped VOA does not reach the setpoint due to an internal problem. The alarm indicates that the attenuation has crossed the low degrade threshold. The alarmed card should be replaced at the next opportunity.

**Note**

For more information about provisioning VOA setpoints, refer to the “Network Reference” chapter of the *Cisco ONS 15454 DWDM Reference Manual*. For general information about DWDM cards, refer to the “Card Reference” chapter in the same manual.

### Clear the VOA-LDEG Alarm

- 
- Step 1** Complete the “[Physically Replace a Card](#)” procedure on page 2-244 for the alarmed card.
- Step 2** If the alarm does not clear, log into the Technical Support Website at <http://www.cisco.com/techsupport> for more information or call Cisco TAC (1-800-553-2447).
- 

## 2.5.316 VOA-LFAIL

Default Severity: Critical (CR), Service-Affecting (SA)

Logical Objects: AOTS, OCH, OMS, OTS

The VOA Low Fail alarm is raised on DWDM cards when an equipped VOA does not reach the setpoint due to an internal problem. The alarm indicates that the attenuation has crossed the low fail threshold. The card must be replaced.

**Note**

For more information about provisioning VOA setpoints, refer to the “Network Reference” chapter of the *Cisco ONS 15454 DWDM Reference Manual*. For general information about DWDM cards, refer to the “Card Reference” chapter in the same manual.

### Clear the VOA-LFAIL Alarm

- 
- Step 1** Complete the “[Physically Replace a Card](#)” procedure on page 2-244 for the alarmed card.
- Step 2** If the alarm does not clear, log into the Technical Support Website at <http://www.cisco.com/techsupport> for more information or call Cisco TAC (1-800-553-2447) in order to report a Service-Affecting (SA) problem.
-

## 2.5.317 VOLT-MISM

Default Severity: Not Alarmed (NA), Non-Service-Affecting (NSA)

Logical Object: PWR

The Power Monitoring Mismatch Between Control Cards alarm is raised against the shelf when the power voltages of both TCC2/TCC2P cards are out of range of each other by more than 5 VDC.

### Clear the VOLT-MISM Condition

- 
- Step 1** Check the incoming voltage level to the shelf using a voltmeter. Follow site practices or refer to the “Install the Shelf and Common Control Cards” chapter in the *Cisco ONS 15454 DWDM Procedure Guide* for power installation procedures.
  - Step 2** Correct any incoming voltage issues.
  - Step 3** If the alarm does not clear, log into the Technical Support Website at <http://www.cisco.com/techsupport> for more information or call Cisco TAC (1-800-553-2447).
- 

## 2.5.318 WKSWPR (2R, EQPT, ESCON, FC, GE, ISC, OTS)

Default Severity: Not Alarmed (NA), Non-Service-Affecting (NSA)

Logical Objects: 2R, EQPT, ESCON, FC, GE, ISC, OTS

This condition is raised when you use the FORCE SPAN, FORCE RING, or MANUAL SPAN command at for a Y-Cable-protected MXP or TXP client port (set for one the above-listed client configurations). WKSWPR is visible on the network view Alarms, Conditions, and History tabs.



#### Note

For more information about protection schemes, refer to the “Manage the Node” chapter of the *Cisco ONS 15454 DWDM Procedure Guide*.

---

## 2.5.319 WKSWPR (TRUNK)

Default Severity: Not Alarmed (NA), Non-Service-Affecting (NSA)

Logical Object: TRUNK

This condition is raised when you use the FORCE SPAN, FORCE RING, or MANUAL SPAN command at for a splitter-protection enabled MXP or TXP trunk port. WKSWPR is visible on the network view Alarms, Conditions, and History tabs.



#### Note

For more information about protection schemes, refer to the “Manage the Node” chapter of the *Cisco ONS 15454 DWDM Procedure Guide*.

---



## 2.5.320 WTR (2R, ESCON, FC, GE, ISC)

Default Severity: Not Alarmed (NA), Non-Service-Affecting (NSA)

Logical Objects: 2R, ESCON, FC, GE, ISC

The Wait To Restore condition occurs for client ports in the above-listed types of configuration in a Y-cable protection group when the “[WKSWPR \(TRUNK\)](#)” condition, [page 2-232](#), is raised. The condition occurs when the wait-to-restore time has not expired, meaning that the active protect path cannot revert to the working path. The condition clears when the timer expires and traffic switches back to the working path.



**Note**

---

WTR is an informational condition and does not require troubleshooting.

---

## 2.5.321 WTR (TRUNK)

Default Severity: Not Alarmed (NA), Non-Service-Affecting (NSA)

Logical Object: TRUNK

The Wait To Restore condition occurs when the “[WKSWPR \(TRUNK\)](#)” condition, [page 2-232](#), is raised for MXP or TXP splitter protection scheme ports. The condition occurs when the wait-to-restore time has not expired, meaning that the active protect path cannot revert to the working path. The condition clears when the timer expires and traffic switches back to the working path.



**Note**

---

WTR is an informational condition and does not require troubleshooting.

---

## 2.5.322 WVL-MISMATCH

Default Severity: Major (MJ), Service-Affecting (SA)

Logical Object: TRUNK

The Equipment Wavelength Mismatch alarm applies to the following cards: TXP\_MR\_2.5G, TXPP\_MR\_2.5G, TXP\_MR\_10E, TXP\_MR\_10E\_C, TXP\_MR\_10E\_L, MXP\_2.5G\_10G, MXP\_2.5G\_10E, MXP\_2.5G\_10E\_C, MXP\_2.5G\_10E\_L, MXP\_MR\_2.5G, MXPP\_MR\_2.5G, MXP\_MR\_10DME\_C, MXPP\_MR\_10DME\_C, ADM-10G, and OTU2\_XP cards. It occurs when you provision the card in CTC with a wavelength that the card does not support.



**Note**

---

For more information about supported card wavelengths, refer to the “Hardware Specifications” appendix in the *Cisco ONS 15454 DWDM Reference Manual*.

---

### Clear the WVL-MISMATCH alarm

- 
- Step 1** In node view (single-shelf mode) or shelf view (multishelf mode), double-click the TXP or MXP card to open the card view.
  - Step 2** Click the **Provisioning > Line > Wavelength Trunk Provisioning** tabs.
  - Step 3** In the Wavelength field, view the provisioned card wavelength.

- Step 4** If you have access to the site, compare the wavelength listed on the card faceplate with the provisioned wavelength. If you are remote, compare this wavelength with the card identification in the inventory:
- In node view (single-shelf mode) or shelf view (multishelf mode), click the **Inventory** tab.
  - Locate the slot where the TXP or MXP card is installed and view the card wavelength in the name.
- Step 5** If the card was provisioned for the wrong wavelength, double-click the card in node view (single-shelf mode) or shelf view (multishelf mode) to open the card view.
- Step 6** Click the **Provisioning > Line > Wavelength Trunk Provisioning** tabs.
- Step 7** In the Wavelength field, click the drop-down list and choose the correct wavelength.
- Step 8** Click **Apply**.
- If the wavelength does not appear because the wavelength band of the card, either C or L, differs from the band that was provisioned in CTC, complete the following steps:
- In the Wavelength field, click the drop-down list and choose **First Tunable Wavelength**.
  - Click **Apply**.
  - In the Wavelength field, click the drop-down list and choose the correct wavelength.
  - Click **Apply**.
- Step 9** If the alarm does not clear, log into the Technical Support Website at <http://www.cisco.com/techsupport> for more information or call Cisco TAC (1-800-553-2447) in order to report a service-affecting problem.
- 

## 2.6 DWDM Card LED Activity

The following sections list the DWDM card LED sequences during card insertion and reset.

### 2.6.1 DWDM Card LED Activity After Insertion

When an DWDM card is inserted in the shelf, the following LED activities occur:

- The FAIL LED illuminates for approximately 35 seconds.
- The FAIL LED blinks for approximately 40 seconds.
- All LEDs illuminate and then turn off within 5 seconds.
- If new software is being downloaded to the card, the ACT and SF LEDs blink for 20 seconds to 3.5 minutes, depending on the card type.
- The ACT LED illuminates.
- The SF LED stays illuminated until all card ports connect to their far-end counterparts and a signal is present.

### 2.6.2 DWDM Card LED Activity During Reset

When an DWDM card resets (by software or hardware), the following LED activities occur:

- The FAIL LED switches on for few seconds.
- The FAIL LED on the physical card blinks and turns off.

3. The white LED with the letters “LDG” appears on the reset card in CTC.
4. The green ACT LED appears in CTC.

## 2.7 Traffic Card LED Activity

ONS system traffic card LED behavior patterns are listed in the following sections. These sections give behavior for card insertion, reset, and side-switch.

### 2.7.1 Typical Traffic Card LED Activity After Insertion

When a non-DWDM card is inserted, the following LED activities occur:

1. The red FAIL LED turns on and remains illuminated for 20 to 30 seconds.
2. The red FAIL LED blinks for 35 to 45 seconds.
3. All LEDs blink once and turn off for 5 to 10 seconds.
4. The ACT or ACT/SBY LED turns on. The SF LED can persist until all card ports connect to their far-end counterparts and a signal is present.

### 2.7.2 Typical Traffic Card LED Activity During Reset

While a non-DWDM card resets, the following LED activities occur:

1. The FAIL LED on the physical card blinks and turns off.
2. The white LED with the letters “LDG” appears on the reset card in CTC.
3. The green ACT LED appears in CTC.

### 2.7.3 Typical Card LED State After Successful Reset

When a non-DWDM card successfully resets, the following LED states are present:

- If you are looking at the physical ONS system, the ACT/SBY LED is illuminated.
- If you are looking at node view (single-shelf mode) or shelf view (multishelf mode) of the ONS system, the current standby card has an amber LED depiction with the initials “SBY,” and this has replaced the white “LDG” depiction on the card in CTC.
- If you are looking at node view (single-shelf mode) or shelf view (multishelf mode) of the ONS system, the current active card has a green LED depiction with the initials “ACT,” and this has replaced the white “LDG” depiction on the card in CTC.

## 2.8 Frequently Used Alarm Troubleshooting Procedures

This section gives common procedures that are frequently used when troubleshooting alarms. Most of these procedures are summarized versions of fuller procedures existing elsewhere in the ONS system documentation. They are included in this chapter for the user's convenience. For further information, please refer to the *Cisco ONS 15454 DWDM Procedure Guide* or the *Cisco ONS 15454 DWDM Reference Manual* as appropriate to your purpose

### 2.8.1 Node and Ring Identification, Change, Visibility, and Termination

The following procedures relate how to identify or change BLSR names and node IDs, and how to verify visibility from other nodes.

#### Identify a BLSR Ring Name or Node ID Number

---

- Step 1** Log into a node on the network.
  - Step 2** In node view, choose **Go to Network View from the View menu**.
  - Step 3** Click the **Provisioning > BLSR** tabs.
  - Step 4** From the Ring Name column, record the ring name, or in the Nodes column, record the Node IDs in the BLSR. The Node IDs are the numbers in parentheses next to the node name.
- 

#### Change a BLSR Ring Name

---

- Step 1** Log into a node on the network.
  - Step 2** In node view, choose **Go to Network View from the View menu**.
  - Step 3** Click the **Provisioning > BLSR** tabs.
  - Step 4** Highlight the ring and click **Edit**.
  - Step 5** In the BLSR window, enter the new name in the Ring Name field.
  - Step 6** Click **Apply**.
  - Step 7** Click **Yes** in the Changing Ring Name dialog box.
- 

#### Change a BLSR Node ID Number

---

- Step 1** Log into a node on the network.
- Step 2** In node view, choose **Go to Network View from the View menu**.
- Step 3** Click the **Provisioning > BLSR** tabs.
- Step 4** Highlight the ring and click **Edit**.
- Step 5** In the BLSR window, right-click the node on the ring map.

- Step 6** Select **Set Node ID** from the shortcut menu.
  - Step 7** In the Edit Node ID dialog box, enter the new ID. The Node ID is the number in parentheses after the Node Name.
  - Step 8** Click **OK**.
- 

## Verify Node Visibility for Other Nodes

---

- Step 1** Log into a node on the network.
  - Step 2** In node view, click the **Provisioning > BLSR** tabs.
  - Step 3** Highlight a BLSR.
  - Step 4** Click **Ring Map**.
  - Step 5** In the BLSR Ring Map window, verify that each node in the ring appears on the ring map with a node ID and IP address.
  - Step 6** Click **Close**.
- 

## 2.8.2 Protection Switching, Lock Initiation, and Clearing

The following sections give instructions for port, ring, and span switching and switch-clearing commands, as well as lock-ons and lockouts.

### Initiate a 1+1 Protection Port Force Switch Command

The following sections give instructions for port switching and switch-clearing commands.

---

- Step 1** In node view (single-shelf mode) or shelf view (multishelf mode), click the **Maintenance > Protection** tabs.
  - Step 2** In the Protection Groups area, select the protection group with the port you want to switch.
  - Step 3** In the Selected Groups area, select the port belonging to the card you are replacing. You can carry out this command for the working or protect port. For example, if you need to replace the card with the Protect/Standby port, click this port.
  - Step 4** In the Switch Commands area, click **Force**.
  - Step 5** Click **Yes** in the Confirm Force Operation dialog box.
  - Step 6** If the switch is successful, the group says “Force to working” in the Selected Groups area.
- 

### Initiate a 1+1 Manual Switch Command

This procedure switches 1+1 protection group traffic from one port in the group to the other using a Manual switch.

**Note**

A Manual command switches traffic if the path has an error rate less than the signal degrade. A Manual switch is preempted by a Force switch.

- 
- Step 1** In node view (single-shelf mode) or shelf view (multishelf mode), click the **Maintenance > Protection** tabs.
- Step 2** In the Protection Groups area, select the protection group with the port you want to switch.
- Step 3** In the Selected Groups area, select the port belonging to the card you are replacing. You can carry out this command for the working or protect port. For example, if you need to replace the card with the protect/standby port, click this port.
- Step 4** In the Switch Commands area, click **Manual**.
- Step 5** Click **Yes** in the Confirm Force Operation dialog box.
- Step 6** If the switch is successful, the group now says “Manual to working” in the Selected Groups area.
- 

## Initiate a 1:1 Card Switch Command

**Note**

The Switch command only works on the active card, whether this card is working or protect. It does not work on the standby card.

- 
- Step 1** In node view, click the **Maintenance > Protection** tabs.
- Step 2** Click the protection group that contains the card you want to switch.
- Step 3** Under Selected Group, click the active card.
- Step 4** Next to Switch Commands, click **Switch**.
- The working slot should change to Working/Active and the protect slot should change to Protect/Standby.
- 

## Clear a 1+1 Force or Manual Switch Command

**Note**

If the 1+1 protection group is configured as revertive, clearing a Force switch to protect (or working) moves traffic back to the working port. In revertive operation, the traffic always switches back to working. There is no revert to the protect. If ports are not configured as revertive, clearing a Force switch to protect does not move traffic back.

**Note**

If the Force Switch was user-initiated, the reversion occurs immediately when the clear command is issued. The five-minute WTR period is not needed in this case. If the Force was system-initiated, allow the five-minute waiting period (during WTR) before the reversion occurs.

---

- 
- Step 1** In node view (single-shelf mode) or shelf view (multishelf mode), click the **Maintenance > Protection** tabs.
- Step 2** In the Protection Groups area, choose the protection group containing the port you want to clear.
- Step 3** In the Selected Group area, choose the port you want to clear.
- Step 4** In the Switching Commands area, click **Clear**.
- Step 5** Click **Yes** in the Confirmation Dialog box.
- The Force switch is cleared. Traffic immediately reverts to the working port if the group was configured for revertive switching.
- 

## Initiate a Lock-On Command



**Note** For 1:1 and 1:N electrical protection groups, working or protect cards can be placed in the Lock On state. For a 1+1 optical protection group, only the working port can be placed in the Lock On state.

---

- Step 1** In node view (single-shelf mode) or shelf view (multishelf mode), click the **Maintenance > Protection** tabs.
- Step 2** In the Protection Groups list, click the protection group where you want to apply a lock-on.
- Step 3** If you determine that the protect card is in standby mode and you want to apply the lock-on to the protect card, make the protect card active if necessary:
- In the Selected Group list, click the protect card.
  - In the Switch Commands area, click **Force**.
- Step 4** In the Selected Group list, click the active card where you want to lock traffic.
- Step 5** In the Inhibit Switching area, click **Lock On**.
- Step 6** Click **Yes** in the confirmation dialog box.
- 

## Initiate a Card or Port Lockout Command



**Note** For 1:1 or 1:N electrical protection groups, working or protect cards can be placed in the Lock Out state. For a 1+1 optical protection group, only the protect port can be placed in the Lock Out state.

---

- Step 1** In node view (single-shelf mode) or shelf view (multishelf mode), click the **Maintenance > Protection** tabs.
- Step 2** In the Protection Groups list, click the protection group that contains the card you want to lockout.
- Step 3** In the Selected Group list, click the card where you want to lock out traffic.
- Step 4** In the Inhibit Switching area, click **Lock Out**.
- Step 5** Click **Yes** in the confirmation dialog box.

The lockout has been applied and traffic is switched to the opposite card.

---

## Clear a Lock-On or Lockout Command

---

- Step 1** In node view (single-shelf mode) or shelf view (multishelf mode), click the **Maintenance > Protection** tabs.
  - Step 2** In the Protection Groups list, click the protection group that contains the card you want to clear.
  - Step 3** In the Selected Group list, click the card you want to clear.
  - Step 4** In the Inhibit Switching area, click **Unlock**.
  - Step 5** Click **Yes** in the confirmation dialog box.
- The lock-on or lockout is cleared.

## Initiate a Lockout on a BLSR Protect Span

---

- Step 1** From the View menu choose **Go to Network View**.
  - Step 2** Click the **Provisioning > BLSR** tabs.
  - Step 3** Choose the BLSR and click **Edit**.
  - Step 4** Right-click the BLSR node channel (port) and choose **Set West Protection Operation** (if you chose a west channel) or **Set East Protection Operation** (if you chose an east channel).
  - Step 5** In the Set West Protection Operation dialog box or the Set East Protection Operation dialog box, choose **Lockout Protect Span** from the drop-down list.
  - Step 6** Click **OK**.
  - Step 7** Click **Yes** in the two Confirm BLSR Operation dialog boxes.
- 
- 

## Clear a BLSR External Switching Command

---

- Step 1** Log into a node on the network.
- Step 2** From the View menu, choose **Go to Network View**.
- Step 3** Click the **Provisioning > BLSR** tabs.
- Step 4** Click the BLSR you want to clear.
- Step 5** Right-click the west port of the BLSR node where you invoked the switch and choose **Set West Protection Operation**.
- Step 6** In the Set West Protection Operation dialog box, choose **Clear** from the drop-down list.
- Step 7** Click **OK**.



- Step 8** Click **Yes** in the Confirm BLSR Operation dialog box.
- 

## 2.8.3 CTC Card Resetting and Switching

This section gives instructions for resetting traffic cards and TCC2/TCC2P cards.

**Caution**

For TXP and MXP cards placed in a Y-cable protection group, do not perform a software reset on both cards simultaneously. Doing so will cause a traffic hit of more than one minute. For more information about Y-cable protection groups, refer to the “Card Reference” chapter of the *Cisco ONS 15454 DWDM Reference Manual*.

---

**Caution**

Resetting the active card in a Y-cable group will cause a traffic outage if the standby card is down for any reason.

---

**Note**

When an AIC-I card is rest in CTC, any subsequent user client operations (such as CTC or TL1 activity) is paused for approximately 5-10 seconds. The reset does not cause any conditions to be raised.

---

**Note**

For more information about MXP and TXP cards, refer to the “Card Reference” chapter of the *Cisco ONS 15454 DWDM Reference Manual*.

---

### Reset a Card in CTC

- Step 1** Log into a node on the network. If you are already logged in, continue with [Step 2](#).
- Step 2** In node view (single-shelf mode) or shelf view (multishelf mode), position the cursor over the optical or electrical traffic card slot reporting the alarm.
- Step 3** Right-click the card. Choose **Reset Card** from the shortcut menu.
- Step 4** Click **Yes** in the Resetting Card dialog box.
- 

### Reset an Active TCC2/TCC2P Card and Activate the Standby Card

**Caution**

Resetting an active TCC2/TCC2P card can be service-affecting.

---

**Note**

Before you reset the TCC2/TCC2P card, you should wait at least 60 seconds after the last provisioning change you made to avoid losing any changes to the database.

---

- 
- Step 1** Log into a node on the network. If you are already logged in, continue with [Step 2](#).
- Step 2** Identify the active TCC2/TCC2P card:  
If you are looking at the physical ONS system shelf, the ACT/SBY LED of the active card is green. The ACT/STBLY LED of the standby card is amber.
- Step 3** In node view (single-shelf mode) or shelf view (multishelf mode), right-click the active TCC2/TCC2P card in CTC.
- Step 4** Choose **Reset Card** from the shortcut menu.
- Step 5** Click **Yes** in the Confirmation Dialog box.  
The card resets, the FAIL LED blinks on the physical card, and connection to the node is lost. CTC switches to network view.
- Step 6** Verify that the reset is complete and error-free and that no new related alarms appear in CTC. For LED appearance, see the [“2.7.3 Typical Card LED State After Successful Reset”](#) section on page 2-235.
- Step 7** Double-click the node and ensure that the reset TCC2/TCC2P card is in standby mode and that the other TCC2/TCC2P card is active. Verify the following:
- If you are looking at the physical ONS system shelf, the ACT/SBY LED of the active card is green. The ACT/STBLY LED of the standby card is amber.
  - No new alarms appear in the Alarms window in CTC.
- 

## 2.8.4 Physical Card Reseating, Resetting, and Replacement

This section gives instructions for physically reseating and replacing TCC2/TCC2P cards and traffic cards.



### Caution

Do not physically replace a card without first making provisions to switch or move traffic to a different card or circuit. General procedures for this are located in the [“2.8.2 Protection Switching, Lock Initiation, and Clearing”](#) section on page 2-237.

---

### Remove and Reinsert (Reseat) the Standby TCC2/TCC2P Card



### Warning

**Warning: High-performance devices on this card can get hot during operation. To remove the card, hold it by the faceplate and bottom edge. Allow the card to cool before touching any other part of it or before placing it in an antistatic bag. Statement 201**

---



### Caution

Always use the supplied electrostatic discharge wristband when working with a powered ONS system. Plug the wristband cable into the ESD jack located on the lower-right edge of the shelf assembly.

---



### Caution

Do not perform this action without the supervision and direction of Cisco TAC (1-800-553-2447).

---

**Caution**

The TCC2/TCC2P card reset could be service-affecting. Refer to the “[2.8.2 Protection Switching, Lock Initiation, and Clearing](#)” section on page 2-237 for traffic-switching procedures.

**Note**

Before you reset the TCC2/TCC2P card, you should wait at least 60 seconds after the last provisioning change you made to avoid losing any changes to the database.

**Note**

When a standby TCC2/TCC2P card is removed and reinserted (reseated), all three fan lights could momentarily turn on, indicating that the fans have also reset.

**Step 1**

Log into a node on the network.

Ensure that the TCC2/TCC2P card you want to reset is in standby mode. A standby card has an amber ACT/SBY (Active/Standby) LED illuminated.

**Step 2**

When the TCC2/TCC2P card is in standby mode, unlatch both the top and bottom ejectors on the TCC2/TCC2P card.

**Step 3**

Physically pull the card at least partly out of the slot until the lighted LEDs turn off.

**Step 4**

Wait 30 seconds. Reinsert the card and close the ejectors.

**Note**

The TCC2/TCC2P card requires several minutes to reboot and display the amber standby LED after rebooting. Refer to the *xxx Cisco ONS 15454 DWDM Reference Manual* for more information about LED behavior during a card reboot.

## Remove and Reinsert (Reseat) Any Card

**Warning**

**Warning: High-performance devices on this card can get hot during operation. To remove the card, hold it by the faceplate and bottom edge. Allow the card to cool before touching any other part of it or before placing it in an antistatic bag. Statement 201**

**Caution**

Always use the supplied electrostatic discharge wristband when working with a powered ONS system. Plug the wristband cable into the ESD jack located on the lower-right edge of the shelf assembly.

**Step 1**

Open the card ejectors.

**Step 2**

Slide the card halfway out of the slot along the guide rails.

**Step 3**

Slide the card all the way back into the slot along the guide rails.

**Step 4**

Close the ejectors.

## Physically Replace a Card



### Warning

**Warning: High-performance devices on this card can get hot during operation. To remove the card, hold it by the faceplate and bottom edge. Allow the card to cool before touching any other part of it or before placing it in an antistatic bag. Statement 201**



### Caution

Always use the supplied electrostatic discharge wristband when working with a powered ONS system. Plug the wristband cable into the ESD jack located on the lower-right edge of the shelf assembly.



### Caution

Removing an active card can cause a traffic hit. To avoid this, perform an external switch if a switch has not already occurred. See the [“2.8.2 Protection Switching, Lock Initiation, and Clearing”](#) section on [page 2-237](#) for commonly used traffic-switching procedures.

When you replace a card with the identical type of card, you do not need to make any changes to the database.

- 
- Step 1** Open the card ejectors.
  - Step 2** Slide the card out of the slot.
  - Step 3** Open the ejectors on the replacement card.
  - Step 4** Slide the replacement card into the slot along the guide rails.
  - Step 5** Close the ejectors.
- 

## 2.8.5 Generic Signal and Circuit Procedures

This section gives instructions for verify BER thresholds, deleting circuits, provisioning SDCC (or MS DCC) terminations, and clearing loopbacks.

### Verify the Signal BER Threshold Level

This procedure is used for MXP or TXP cards.

- 
- Step 1** Log into a node on the network.
  - Step 2** In node view (single-shelf mode) or shelf view (multishelf mode), double-click the card reporting the alarm to open the card view.
  - Step 3** Click the **Provisioning > Line > SONET (or SDH)** tabs.
  - Step 4** Under the **SD BER** (or **SF BER**) column in the Provisioning window, verify that the cell entry is consistent with the originally provisioned threshold. The default setting is 1E-7.
  - Step 5** If the entry is consistent with the original provisioning, go back to your original procedure.
  - Step 6** If the entry is not consistent with what the system was originally provisioned for, click the cell to reveal the range of choices and click the original entry.

**Step 7** Click **Apply**.

---

## Delete a Circuit

---

- Step 1** Log into a node on the network.
- Step 2** In node view (single-shelf mode) or shelf view (multishelf mode), click the **Circuits** tab.
- Step 3** Click the circuit row to highlight it and click **Delete**.
- Step 4** Click **Yes** in the Delete Circuits dialog box.
- 

## Verify or Create Node Section DCC Terminations

---

- Step 1** Log into a node on the network.
- Step 2** In node view (single-shelf mode) or multishelf view (multishelf mode), click the **Provisioning > Comm Channels > SDCC (or Provisioning > Comm Channels > MS DCC)** tab.
- Step 3** View the Port column entries to see where terminations are present for a node. If terminations are missing, proceed to [Step 4](#).
- Step 4** If necessary, create a DCC termination:
- Click **Create**.
  - In the Create SDCC Terminations (or Create MS DCC Terminations) dialog box, click the ports where you want to create the DCC termination. To select more than one port, press the Shift key.
  - In the port state area, click the **Set to IS or Unlocked (or Set to Unlocked)** radio button.
  - Verify that the Disable OSPF on Link check box is unchecked.
  - Click **OK**.
- 

## Clear an MXP, TXP, GE-XP, 10GE-XP, and ADM-10G Card Loopback Circuit

---

- Step 1** Log into a node on the network.
- Step 2** In node view (single-shelf mode) or shelf view (multishelf mode), double-click the reporting card in CTC to open the card view.
- Step 3** Click the **Maintenance > Loopback** tabs.
- Step 4** In the Loopback Type column, determine whether any port row shows a state other than None.
- Step 5** If a row contains another state besides None, click in the column cell to display the drop-down list and select None.
- Step 6** In the Admin State column, determine whether any port row shows an administrative state other than IS or Unlocked, for example, OOS,MT or Locked,maintenance.
- Step 7** If a row shows an administrative state other than IS or Unlocked, click in the column cell to display the drop-down list and select **IS** , or **Unlocked**.



**Note** If ports managed into IS (or Unlocked) administrative state are not receiving signals, the LOS alarm is either raised or remains, and the port service state transitions to OOS-AU,FLT (or Locked-disabled, automaticInService & failed).

**Step 8** Click **Apply**.

---

## Verify or Create Node RS-DCC Terminations



**Note** Portions of this procedure are different for ONS 15454 DWDM nodes.

---

- Step 1** Log into a node on the network. If you are already logged in, continue with [Step 2](#).
- Step 2** In node view, click the **Provisioning > Comm Channels > RS-DCC** tab.
- Step 3** View the Port column entries to see where terminations are present for a node. If terminations are missing, proceed to [Step 4](#).
- Step 4** If necessary, create a DCC termination by completing the following steps:
- a. Click **Create**.
  - b. In the Create RS-DCC Terminations dialog box, click the ports where you want to create the DCC termination. To select more than one port, press the Shift key.
  - c. In the port state area, click the **Set to Unlocked** radio button.
  - d. Verify that the Disable OSPF on Link check box is unchecked.
  - e. Click **OK**.
- 

## Clear an STM-N Card XC Loopback Circuit

- Step 1** Log into a node on the network. If you are already logged in, continue with [Step 2](#).
- Step 2** Double-click the reporting card in CTC to display the card view.
- Step 3** Click the **Maintenance > Loopback > VC4** tabs.
- Step 4** Click **Apply**.
- 

## 2.8.6 Air Filter and Fan Procedures

This section gives instructions for cleaning or replacing the air filter and reseating or replacing the fan tray assembly.

## Inspect, Clean, and Replace the Reusable Air Filter

To complete this task, you need a vacuum cleaner or detergent and water faucet, a spare filter, and a pinned hex key.

**Warning**

**Do not reach into a vacant slot or chassis while you install or remove a module or a fan. Exposed circuitry could constitute an energy hazard.** Statement 206

Although the filter works if it is installed with either side facing up, Cisco recommends that you install it with the metal bracing facing up to preserve the surface of the filter.

**Caution**

Always use the supplied electrostatic discharge wristband when working with a powered ONS system. Plug the wristband cable into the ESD jack located on the lower-right edge of the shelf assembly.

- 
- Step 1** Verify that you are replacing a reusable air filter. The reusable filter is made of a gray, open-cell, polyurethane foam that is specially coated to provide fire and fungi resistance. NEBS 3E and later versions of the ONS system use a reusable air filter.
- Step 2** If the air filter is installed in the external filter brackets, slide the filter out of the brackets while being careful not to dislodge any dust that could have collected on the filter. If the filter is installed beneath the fan tray and not in the external filter brackets, open and remove the front door assembly by completing the following steps:
- a. Open the front door of the shelf assembly by completing the following substeps. (If it is already open or if the shelf assembly does not have a front door, continue with [Step 3](#).)
    - Open the front door lock.
    - Press the door button to release the latch.
    - Swing the door open.
  - b. Remove the front door by completing the following substeps (optional):
    - Detach the ground strap from either the door or the chassis by removing one of the Kepnuts.
    - Place the Kepnut back on the stud after the ground strap is removed to avoid misplacement.
    - Secure the dangling end of the ground strap to the door or chassis with tape.
- Step 3** Push the outer side of the handles on the fan-tray assembly to expose the handles.
- Step 4** Pull the handles and slide the fan-tray assembly one inch (25.4 mm) out of the shelf assembly and wait until the fans stop.
- Step 5** When the fans have stopped, pull the fan-tray assembly completely out of the shelf assembly.
- Step 6** Gently remove the air filter from the shelf assembly. Be careful not to dislodge any dust that could have collected on the filter.
- Step 7** Visually inspect the air filter material for dirt and dust.
- Step 8** If the reusable air filter has a concentration of dirt and dust, either vacuum or wash the air filter. Prior to washing the air filter, replace the dirty air filter with a clean air filter and also reinsert the fan-tray assembly. Wash the dirty air filter under a faucet with a light detergent.
- Spare ONS system filters should be kept in stock for this purpose.



---

**Note** Cleaning should take place outside the operating environment to avoid releasing dirt and dust near the equipment.

---

**Step 9** If you washed the filter, allow it to completely air dry for at least eight hours.



---

**Caution** Do not put a damp filter back in the ONS system.

---

**Step 10** If the air filter should be installed in the external filter brackets, slide the air filter all the way to the back of the brackets to complete the procedure.

**Step 11** If the filter should be installed beneath the fan-tray assembly, remove the fan-tray assembly and slide the air filter into the recessed compartment at the bottom of the shelf assembly. Put the front edge of the air filter flush against the front edge of the recessed compartment. Push the fan tray back into the shelf assembly.



---

**Caution** If the fan tray does not slide all the way to the back of the shelf assembly, pull the fan tray out and readjust the position of the reusable filter until the fan tray fits correctly.

---



---

**Note** On a powered-up ONS system, the fans start immediately after the fan-tray assembly is correctly inserted.

---

**Step 12** To verify that the tray is plugged into the backplane, ensure that the LCD on the front of the fan-tray assembly is activated and displays node information.

**Step 13** Rotate the retractable handles back into their compartments.

**Step 14** Replace the door and reattach the ground strap.

---

## Remove and Reinsert a Fan-Tray Assembly

---

**Step 1** Use the retractable handles embedded in the front of the fan-tray assembly to pull it forward several inches.

**Step 2** Push the fan-tray assembly firmly back into the ONS system.

**Step 3** Close the retractable handles.

---



## Replace the Fan-Tray Assembly

**Caution**

The 15454-FTA3 fan-tray assembly can only be installed in ONS 15454 system R3.1 and later shelf assemblies (15454-SA-ANSI, P/N: 800-19857; 15454-SA-HD, P/N: 800-24848). It includes a pin that does not allow it to be installed in ONS 15454 shelf assemblies released before ONS 15454 R3.1 (15454-SA-NEBS3E, 15454-SA-NEBS3, and 15454-SA-R1, P/N: 800-07149). Equipment damage can result from attempting to install the 15454-FTA3 in a incompatible shelf assembly.

**Caution**

Do not force a fan-tray assembly into place. Doing so can damage the connectors on the fan tray and/or the connectors on the backplane.

**Caution**

Always use the supplied electrostatic discharge wristband when working with a powered ONS system. Plug the wristband cable into the ESD jack located on the lower-right edge of the shelf assembly.

To replace the fan-tray assembly, it is not necessary to move any of the cable management facilities.

- 
- Step 1** Open the front door of the shelf assembly by completing the following steps. If the shelf assembly does not have a front door, continue with [Step 3](#).
- Open the front door lock.
  - Press the door button to release the latch.
  - Swing the door open.
- Step 2** Remove the front door (optional):
- Detach the ground strap from either the door or the chassis by removing one of the Kepnuts.
  - Place the Kepnut back on the stud after the ground strap is removed to avoid misplacement.
  - Secure the dangling end of the ground strap to the door or chassis with tape.
- Step 3** Push the outer side of the handles on the fan-tray assembly to expose the handles.
- Step 4** Fold out the retractable handles at the outside edges of the fan tray.
- Step 5** Pull the handles and slide the fan-tray assembly one inch (25.4 mm) out of the shelf assembly and wait until the fans stop.
- Step 6** When the fans have stopped, pull the fan-tray assembly completely out of the shelf assembly.
- Step 7** If you are replacing the fan-tray air filter and it is installed beneath the fan-tray assembly, slide the existing air filter out of the shelf assembly and replace it before replacing the fan-tray assembly.
- If you are replacing the fan-tray air filter and it is installed in the external bottom bracket, you can slide the existing air filter out of the bracket and replace it at anytime. For more information on the fan-tray air filter, see the [“Inspect, Clean, and Replace the Reusable Air Filter”](#) section on page 2-247.
- Step 8** Slide the new fan tray into the shelf assembly until the electrical plug at the rear of the tray plugs into the corresponding receptacle on the backplane.
- Step 9** To verify that the tray has plugged into the backplane, check that the LCD on the front of the fan tray is activated.

**Step 10** If you replace the door, be sure to reattach the ground strap.

---

## 2.8.7 Interface Procedures

This section includes instructions for replacing an AIP.

### Replace the Alarm Interface Panel



**Caution**

Do not use a 2A AIP with a 5A fan-tray assembly; doing so causes a blown fuse on the AIP.

---



**Caution**

If any nodes in an Ethernet circuit are not using Software R4.0 or later, there is a risk of Ethernet traffic disruptions. Contact Cisco TAC at 1 800 553-2447 when prompted to do so in the procedure.

---



**Note**

Perform this procedure during a maintenance window. Resetting the active TCC2/TCC2P card can cause a service disruption of less than 50 ms to OC-N or DS-N traffic. Resetting the active TCC2/TCC2P card can cause a service disruption of 3 to 5 minutes on all Ethernet traffic due to spanning tree reconvergence if any nodes in the Ethernet circuit are not using Software R4.0 or later.

---



**Caution**

Do not perform this procedure on a node with live traffic. Hot-swapping the AIP can affect traffic and result in a loss of data. For assistance with AIP replacement contact Cisco TAC (1-800-553-2447).

---



**Caution**

Always use the supplied electrostatic discharge wristband when working with a powered ONS 15454. Plug the wristband cable into the ESD jack located on the lower-right edge of the shelf assembly.

---

This procedure replaces an existing AIP with a new AIP on an in-service node without affecting traffic. Ethernet circuits that traverse nodes with a software release prior to R4.0 is affected.

You need a #2 Phillips screwdriver.

---

**Step 1** Ensure that all nodes in the affected network are running the same software version before replacing the AIP and repairing circuits:

- a. In network view, click the **Maintenance > Software** tabs. The working software version for each node is listed in the Working Version column.
- b. If you need to upgrade the software on a node, refer to the release-specific software upgrade document for procedures. No hardware should be changed or circuit repair performed until after the software upgrade is complete. If you do not need to upgrade software or have completed the software upgrade, proceed to [Step 2](#).

**Step 2** Record the MAC address of the old AIP:

- a. Log into the node where you are replacing the AIP. For login procedures, refer to the “Connect the PC and Log into the GUI” chapter in the *Cisco ONS 15454 Procedure Guide*.

- b. In node view, click the **Provisioning > Network > General** tabs.
- c. Record the MAC address.

- Step 3** Call Cisco TAC (1-800-553-2447) for assistance in replacing the AIP and maintaining the original MAC address.
- Step 4** Unscrew the five screws that hold the lower backplane cover in place.
- Step 5** Grip the lower backplane cover and gently pull it away from the backplane.
- Step 6** Unscrew the two screws that hold the AIP cover in place.
- Step 7** Grip the cover and gently pull away from the backplane.



---

**Note** On the 15454-SA-HD (P/N: 800-24848), 15454-SA-NEBS3E, 15454-SA-NEBS3, and 15454-SA-R1 (P/N: 800-07149) shelves the AIP cover is clear plastic. On the 15454-SA-ANSI shelf (P/N: 800-19857), the AIP cover is metal.

---

- Step 8** Grip the AIP and gently pull it away from the backplane.
- Step 9** Disconnect the fan-tray assembly power cable from the AIP.
- Step 10** Set the old AIP aside for return to Cisco.



---

**Caution** The type of shelf the AIP resides in determines the version of AIP that should replace the failed AIP. The 15454-SA-ANSI shelf (P/N: 800-19857) and 15454-SA-HD (P/N: 800-24848) currently use the 5A AIP, (P/N: 73-7665-01). The 15454-SA-NEBS3E, 15454-SA-NEBS3, and 15454-SA-R1 (P/N: 800-07149) shelves and earlier use the 2A AIP (P/N: 73-5262-01).

---



---

**Caution** Do not put a 2A AIP (P/N: 73-5262-01) into a 15454-SA-ANSI (P/N: 800-19857) or 15454-SA-HD (P/N: 800-24848) shelf; doing so causes a blown fuse on the AIP.

---

- Step 11** Attach the fan-tray assembly power cable to the new AIP.
- Step 12** Place the new AIP on the backplane by plugging the panel into the backplane using the DIN connector.
- Step 13** Replace the AIP cover over the AIP and secure the cover with the two screws.
- Step 14** Replace the lower backplane cover and secure the cover with the five screws.
- Step 15** In node view, click the **Provisioning > Network** tabs.



---

**Caution** Cisco recommends TCC2/TCC2P card resets be performed in a maintenance window to avoid any potential service disruptions.

---

- Step 16** Reset the standby TCC2/TCC2P card:
- a. Right-click the standby TCC2/TCC2P card and choose **Reset Card**.
  - b. Click **Yes** in the Resetting Card dialog box. As the card resets, a loading (Ldg) indication appears on the card in CTC. The reset takes approximately five minutes. Do not perform any other steps until the reset is complete.
- Step 17** Reset the active TCC2/TCC2P card:
- a. Right click the active TCC2/TCC2P card and choose **Reset Card**.





## Transient Conditions

This chapter gives a description, entity, Simple Network Management Protocol (SNMP) number, and trap for each commonly encountered Cisco ONS 15454 transient condition.



**Note**

Unless otherwise specified, ONS 15454 refers to both ANSI and ETSI shelf assemblies.

### 3.1 Transients Indexed By Alphabetical Entry

Table 3-1 alphabetically lists all ONS 15454 transient conditions and their entity, SNMP number, and SNMP trap.



**Note**

The Cisco Transport Controller (CTC) default alarm profile might contain conditions that are not currently implemented but are reserved for future use.

**Table 3-1** ONS 15454 Transient Condition Alphabetical Index

| Transient Condition                               | Entity | SNMP Number | SNMP Trap                         |
|---------------------------------------------------|--------|-------------|-----------------------------------|
| <a href="#">3.3.1 ADMIN-DISABLE, page 3-4</a>     | NE     | 5270        | disableInactiveUser               |
| <a href="#">3.3.2 ADMIN-DISABLE-CLR, page 3-4</a> | NE     | 5280        | disableInactiveClear              |
| <a href="#">3.3.3 ADMIN-LOCKOUT, page 3-4</a>     | NE     | 5040        | adminLockoutOfUser                |
| <a href="#">3.3.4 ADMIN-LOCKOUT-CLR, page 3-4</a> | NE     | 5050        | adminLockoutClear                 |
| <a href="#">3.3.5 ADMIN-LOGOUT, page 3-4</a>      | NE     | 5020        | adminLogoutOfUser                 |
| <a href="#">3.3.6 ADMIN-SUSPEND, page 3-4</a>     | NE     | 5340        | suspendUser                       |
| <a href="#">3.3.7 ADMIN-SUSPEND-CLR, page 3-5</a> | NE     | 5350        | suspendUserClear                  |
| <a href="#">3.3.8 AUD-ARCHIVE-FAIL, page 3-5</a>  | EQPT   | 6350        | archiveOfAuditLogFailed           |
| <a href="#">3.3.9 AUTOWDMANS, page 3-5</a>        | NE     | 5690        | automaticWdmAnsFinished           |
| <a href="#">3.3.10 BLSR-RESYNC, page 3-5</a>      | OCN    | 2100        | blsrMultiNodeTableUpdateCompleted |
| <a href="#">3.3.11 DBBACKUP-FAIL, page 3-5</a>    | EQPT   | 3724        | databaseBackupFailed              |
| <a href="#">3.3.12 DBRESTORE-FAIL, page 3-5</a>   | EQPT   | 3726        | databaseRestoreFailed             |

**REVIEW DRAFT – CISCO CONFIDENTIAL****Table 3-1 ONS 15454 Transient Condition Alphabetical Index (continued)**

| Transient Condition                   | Entity | SNMP Number | SNMP Trap                                          |
|---------------------------------------|--------|-------------|----------------------------------------------------|
| 3.3.13 EXERCISING-RING, page 3-6      | OCN    | 3400        | exercisingRingSuccessfully                         |
| 3.3.14 EXERCISING-SPAN, page 3-6      | OCN    | 3410        | exercisingSpanSuccessfully                         |
| 3.3.15 FIREWALL-DIS, page 3-6         | NE     | 5230        | firewallHasBeenDisabled                            |
| 3.3.16 FRCDWKSWBK-NO-TRFSW, page 3-6  | OCN    | 5560        | forcedSwitchBackToWorkingResultedInNoTrafficSwitch |
| 3.3.17 FRCDWKSWPR-NO-TRFSW, page 3-6  | OCn    | 5550        | forcedSwitchToProtectResultedInNoTrafficSwitch     |
| 3.3.18 INTRUSION, page 3-6            | NE     | 5250        | securityIntrusionDetUser                           |
| 3.3.19 INTRUSION-PSWD, page 3-7       | NE     | 5240        | securityIntrusionDetPwd                            |
| 3.3.20 IOSCFG-COPY-FAIL, page 3-7     | —      | 3660        | iosConfigCopyFailed                                |
| 3.3.21 LOGIN-FAIL-LOCKOUT, page 3-7   | NE     | 5080        | securityInvalidLoginLockedOut<br>SeeAuditLog       |
| 3.3.22 LOGIN-FAIL-ONALRDY, page 3-7   | NE     | 5090        | securityInvalidLoginAlreadyLoggedInOnSeeAuditLog   |
| 3.3.23 LOGIN-FAILURE-PSWD, page 3-7   | NE     | 5070        | securityInvalidLoginPasswordSeeAuditLog            |
| 3.3.24 LOGIN-FAILURE-USERID, page 3-7 | NE     | 3722        | securityInvalidLoginUsernameSeeAuditLog            |
| 3.3.25 LOGOUT-IDLE-USER, page 3-8     | —      | 5110        | automaticLogoutOfIdleUser                          |
| 3.3.26 MANWKSWBK-NO-TRFSW, page 3-8   | OCN    | 5540        | manualSwitchBackToWorkingResultedInNoTrafficSwitch |
| 3.3.27 MANWKSWPR-NO-TRFSW, page 3-8   | OCN    | 5530        | manualSwitchToProtectResultedInNoTrafficSwitch     |
| 3.3.29 MSSP-RESYNC, page 3-8          | STMN   | 4340        | msspMultiNodeTableUpdateCompleted                  |
| 3.3.30 PM-TCA, page 3-8               | —      | 2120        | performanceMonitorThresholdCrossingAlert           |
| 3.3.31 PS, page 3-8                   | EQPT   | 2130        | protectionSwitch                                   |
| 3.3.32 RMON-ALARM, page 3-9           | —      | 2720        | rmonThresholdCrossingAlarm                         |
| 3.3.33 RMON-RESET, page 3-9           | —      | 2710        | rmonHistoriesAndAlarmsReset<br>Reboot              |
| 3.3.34 SESSION-TIME-LIMIT, page 3-9   | NE     | 6270        | sessionTimeLimitExpired                            |
| 3.3.35 SFTWDOWN-FAIL, page 3-9        | EQPT   | 3480        | softwareDownloadFailed                             |
| 3.3.36 SPAN-NOT-MEASURED, page 3-9    | OTS    | 6440        | spanMeasurementCannotBePerformed                   |
| 3.3.37 SWFTDOWNFAIL, page 3-9         | EQPT   | 3480        | softwareDownloadFailed                             |
| 3.3.38 USER-LOCKOUT, page 3-9         | NE     | 5030        | userLockedOut                                      |
| 3.3.39 USER-LOGIN, page 3-10          | NE     | 5100        | loginOfUser                                        |
| 3.3.40 USER-LOGOUT, page 3-10         | NE     | 5120        | logoutOfUser                                       |

**REVIEW DRAFT – CISCO CONFIDENTIAL****Table 3-1** ONS 15454 Transient Condition Alphabetical Index (continued)

| Transient Condition                          | Entity                                                                        | SNMP Number | SNMP Trap                  |
|----------------------------------------------|-------------------------------------------------------------------------------|-------------|----------------------------|
| <a href="#">3.3.41 WKSWBK, page 3-10</a>     | EQPT,<br>OCN                                                                  | 2640        | switchedBackToWorking      |
| <a href="#">3.3.42 WKSWPR, page 3-10</a>     | 2R,<br>TRUNK,<br>EQPT,<br>ESCON,<br>FC, GE,<br>ISC, OCN,<br>STSMON,<br>VT-MON | 2650        | switchedToProtection       |
| <a href="#">3.3.43 WRMRESTART, page 3-10</a> | NE                                                                            | 2660        | warmRestart                |
| <a href="#">3.3.44 WTR-SPAN, page 3-10</a>   | —                                                                             | 3420        | spanIsInWaitToRestoreState |

## 3.2 Trouble Notifications

The ONS 15454 system reports trouble by using standard condition characteristics that follow the rules in Telcordia GR-253 and graphical user interface (GUI) state indicators.

The ONS 15454 uses standard Telcordia categories to characterize levels of trouble. The system reports trouble notifications as alarms and reports status or descriptive notifications (if configured to do so) as conditions in the CTC Alarms window. Alarms typically signify a problem that you need to remedy, such as a loss of signal. Conditions do not necessarily require troubleshooting.

### 3.2.1 Condition Characteristics

Conditions include any problem detected on an ONS 15454 shelf. They can include standing or transient notifications. You can retrieve a snapshot of all currently raised conditions on the network, node, or card in the CTC Conditions window or by using the RTRV-COND commands in Transaction Language One (TL1).

**Note**

Some cleared conditions are found on the History tab.

For a comprehensive list of conditions, refer to the *Cisco ONS SONET TL1 Command Guide* and the *Cisco ONS 15454 SDH and Cisco ONS 15600 SDH TL1 Command Guide*.

### 3.2.2 Condition States

The History tab state (ST) column indicates the disposition of the condition, as follows:

- A raised (R) event is active.
- A cleared (C) event is no longer active.
- A transient (T) event is automatically raised and cleared in CTC during system changes such as user login, log out, and loss of connection to node view. Transient events do not require user action.

**REVIEW DRAFT – CISCO CONFIDENTIAL**

## 3.3 Transient Conditions

This section lists in alphabetical order all the transient conditions encountered in Software Release 9.0. The description, entity, SNMP number, and SNMP trap accompany each condition.

### 3.3.1 ADMIN-DISABLE

The Disable Inactive User (ADMIN-DISABLE) condition occurs when the administrator disables a user or when a account is inactive for a specified period.

This transient condition does not result in a standing condition.

### 3.3.2 ADMIN-DISABLE-CLR

The Disable Inactive Clear (ADMIN-DISABLE-CLR) condition occurs when the administrator clears the disable flag on a user account.

This transient condition does not result in a standing condition.

### 3.3.3 ADMIN-LOCKOUT

The Admin Lockout of User (ADMIN-LOCKOUT) condition occurs when the administrator locks a user account.

This transient condition does not result in a standing condition.

### 3.3.4 ADMIN-LOCKOUT-CLR

The Admin Lockout Clear (ADMIN-LOCKOUT-CLR) condition occurs when the administrator unlocks a user account or when the lockout time expires.

This transient condition does not result in a standing condition.

### 3.3.5 ADMIN-LOGOUT

The Admin Logout of User (ADMIN-LOGOUT) condition occurs when the administrator logs off a user session.

This transient condition does not result in a standing condition.

### 3.3.6 ADMIN-SUSPEND

The Suspend User (ADMIN-SUSPEND) condition occurs when the password for a user account expires.

This transient condition does not result in a standing condition.



## REVIEW DRAFT – CISCO CONFIDENTIAL

### 3.3.7 ADMIN-SUSPEND-CLR

The Suspend User Clear (ADMIN-SUSPEND-CLR) condition occurs when the user or administrator changes the password.

This transient condition does not result in a standing condition.

### 3.3.8 AUD-ARCHIVE-FAIL

The Archive of Audit Log Failed (AUD-ARCHIVE-FAIL) condition occurs when the software fails to archive the audit log. The condition normally occurs when the user refers to an FTP server that does not exist, or uses an invalid login while trying to archive. The user must log in again with correct user name, password, and FTP server details.

This transient condition does not lead to a standing condition.

### 3.3.9 AUTOWDMANS

The Automatic WDM ANS Finish (AUTOWDMANS) condition indicates that an automatic node setup (ANS) command has been initiated. It normally occurs when you replace dense wavelength division multiplexing (DWDM) cards; the condition is an indication that the system has regulated the card.

This transient condition does not result in a standing condition.

### 3.3.10 BLSR-RESYNC

The BLSR Multinode Table Update Completed (BLSR-RESYNC) condition might occur when you create or delete circuits on a bidirectional line switched ring (BLSR) or multiplex section-shared protection ring (MS-SPRing), change a ring topology (for example, add or delete a BLSR/MS-SPRing node), or change the BLSR/MS-SPRing circuit state and ring ID.

This transient condition does not result in a standing condition.

### 3.3.11 DBBACKUP-FAIL

The Database Backup Failed (DBBACKUP-FAIL) condition occurs when the system fails to back up the database when the backup command is initiated.

This condition can occur when the server is not able to handle the backup operation due to network or server issues. Repeat the same operation again and check to see if it is successful. If the backup fails, it could be due to a network issue or software program failure. Contact the Cisco Technical Assistance Center (TAC) for assistance; see the [“Obtaining Documentation and Submitting a Service Request” section on page xl](#) as needed.

### 3.3.12 DBRESTORE-FAIL

The Database Restore Failed (DBRESTORE-FAIL) condition occurs when the system fails to restore the backed up database when the restore command is initiated.

## **REVIEW DRAFT – CISCO CONFIDENTIAL**

This condition can be due to server issues, network issues, or human error (pointing to a file that does not exist, wrong file name, etc.). Retrying the database restore with the correct file will usually succeed. If the network issue persists, you must contact network lab support. If the condition is caused by a network element (NE) failure, contact Cisco TAC for assistance. See the “[Obtaining Documentation and Submitting a Service Request](#)” section on page xi as needed.

### **3.3.13 EXERCISING-RING**

The Exercising Ring Successfully (EXERCISING-RING) condition occurs whenever you issue an Exercise Ring command from CTC or TL1. This condition indicates that a command is being executed.

### **3.3.14 EXERCISING-SPAN**

The Exercising Span Successfully (EXERCISING-SPAN) condition occurs whenever you issue an Exercise Span command from CTC or TL1. This condition indicates that a command is being executed.

### **3.3.15 FIREWALL-DIS**

The Firewall Has Been Disabled (FIREWALL-DIS) condition occurs when you provision the firewall to Disabled.

This transient condition does not result in a standing condition.

### **3.3.16 FRCDWKSWBK-NO-TRFSW**

The Forced Switch Back to Working Resulted in No Traffic Switch (FRCDWKSWBK-NO-TRFSW) condition occurs when you perform a Force Switch to the working port or card and the working port or card is already active.

This transient condition might result in a Force Switch (Ring or Span) standing condition for a BLSR or MS-SPRing.

### **3.3.17 FRCDWKSWPR-NO-TRFSW**

The Forced Switch to Protection Resulted in No Traffic Switch (FRCDWKSWPR-NO-TRFSW) condition occurs when you perform a Force Switch to the protect port or card, and the protect port or card is already active.

This transient condition does not result in a standing condition.

### **3.3.18 INTRUSION**

The Invalid Login Username (INTRUSION) condition occurs when you attempt to log in with an invalid user ID.

This transient condition does not result in a standing condition.

**REVIEW DRAFT – CISCO CONFIDENTIAL****3.3.19 INTRUSION-PSWD**

The Security Intrusion Attempt Detected (INTRUSION -PSWD) condition occurs when you attempt to log in with an invalid password.

This transient condition does not result in a standing condition.

**3.3.20 IOSCFG-COPY-FAIL**

The Cisco IOS Config Copy Failed (IOSCFG-COPY-FAIL) condition occurs on ML-Series Ethernet cards when the software fails to upload or download the Cisco IOS startup configuration file to or from an ML-Series card. This condition is similar to the [“SFTWDOWN-FAIL” condition on page 3-9](#), but the IOSCFG-COPY-FAIL condition applies to ML-Series Ethernet cards rather than the TCC2/TCC2P card.

**3.3.21 LOGIN-FAIL-LOCKOUT**

The Invalid Login–Locked Out (LOGIN-FAIL-LOCKOUT) condition occurs when you attempt to log into a locked account.

This transient condition does not result in a standing condition.

**3.3.22 LOGIN-FAIL-ONALRDY**

The Security: Invalid Login–Already Logged On (LOGIN-FAIL-ONALRDY) condition occurs when a user attempts to log into a node where the user already has an existing session and a Single-User-Per-Node (SUPN) policy exists.

This transient condition does not result in a standing condition.

**3.3.23 LOGIN-FAILURE-PSWD**

The Invalid Login–Password (LOGIN-FAILURE-PSWD) condition occurs when you attempt to log in with an invalid password.

This transient condition does not result in a standing condition.

**3.3.24 LOGIN-FAILURE-USERID**

The Invalid Login–Username (LOGIN-FAILURE-USERID) condition occurs when a user login (CTC, Cisco Transport Manager [CTM], or TL1) fails because the login username is not present on the node database. You must log in again with an existing user ID.

This transient condition is equivalent to a security warning. You must check the security log (audit log) for other security-related actions that have occurred.

**REVIEW DRAFT – CISCO CONFIDENTIAL****3.3.25 LOGOUT-IDLE-USER**

The Automatic Logout of Idle User (LOGOUT-IDLE-USER) condition occurs when a user session is idle for too long (the idle timeout expires) and the session terminates as a result. You must log in again to restart your session.

**3.3.26 MANWKSWBK-NO-TRFSW**

The Manual Switch Back To Working Resulted in No Traffic Switch (MANWKSWBK-NO-TRFSW) condition occurs when you perform a Manual switch to the working port or card and the working port or card is already active.

This transient condition does not result in a standing condition.

**3.3.27 MANWKSWPR-NO-TRFSW**

The Manual Switch to Protect Resulted in No Traffic Switch (MANWKSWPR-NO-TRFSW) condition occurs when you perform a Manual switch to the protect port or card and the protect port or card is already active.

This transient condition results in a BLSR or MSSP Manual Switch (Span or Ring) standing condition.

**3.3.28 MCAST-MAC-ALIASING**

This condition is raised when there are multiple L3 addresses that map to the same L2 address in a VLAN.

**3.3.29 MSSP-RESYNC**

The MS-SPRing Multi-Node Table Update Completed (MSSP-RESYNC) condition occurs when a node receives all relevant information such as payload, path state, Routing Information Protocol (RIP), cross-connect tables, and cross-connect VT tables from the other nodes in the ring. This condition is raised on all nodes in the ring while a node is added or a circuit is provisioned. This transient condition will not be cleared and is seen in the History tab of CTC.

You must check this condition on all the nodes and then remove the Forced Ring Switch commands.

**3.3.30 PM-TCA**

The Performance Monitoring Threshold Crossing Alert (PM-TCA) condition occurs when network collisions cross the rising threshold for the first time.

**3.3.31 PS**

The Protection Switch (PS) condition occurs when traffic switches from a working/active card to a protect/standby card.

**REVIEW DRAFT – CISCO CONFIDENTIAL****3.3.32 RMON-ALARM**

The Remote Monitoring Threshold Crossing Alarm (RMON-ALARM) condition occurs when the remote monitoring (RMON) variable crosses the threshold.

**3.3.33 RMON-RESET**

The RMON Histories and Alarms Reset Reboot (RMON-RESET) condition occurs when the time-of-day settings on the TCC2/TCC2P card are increased or decreased by more than five seconds. This invalidates all the history data, and RMON must restart. It can also occur when you reset a card.

**3.3.34 SESSION-TIME-LIMIT**

The Session Time Limit Expired (SESSION-TIME-LIMIT) condition occurs when a login session exceeds the time limit and you are logged out of the session. You must log in again.

**3.3.35 SFTWDOWN-FAIL**

The Software Download Failed (SFTDOWN-FAIL) condition occurs when the system fails to download the required software.

An incorrect input that points to the wrong place or file, network issues, or a bad (corrupt) package can cause this failure. Retrying the operation with the correct name/location will usually succeed. If network issues persist, you must contact the network lab support. If the package is corrupt, contact Cisco TAC. See the [“Obtaining Documentation and Submitting a Service Request”](#) section on page xl for details.

**3.3.36 SPAN-NOT-MEASURED**

The SPAN-NOT-MEASURED condition is raised when a node cannot perform the span loss verification as it cannot communicate with its peer at the other end of the span.

**3.3.37 SWFTDOWNFAIL**

The Software Download Failed (SFTDOWN-FAIL) condition occurs when the system fails to download the required software.

An incorrect input that points to the wrong place or file, network issues, or a bad (corrupt) package can cause this failure. Retrying the operation with the correct name/location will usually succeed. If network issues persist, you must contact the network lab support. If the package is corrupt, contact Cisco TAC. See the [“Obtaining Documentation and Submitting a Service Request”](#) section on page xl for details.

**3.3.38 USER-LOCKOUT**

The User Locked Out (USER-LOCKOUT) condition occurs when the system locks an account because of a failed login attempt. To proceed, the administrator must unlock the account or the lockout time must expire.

**REVIEW DRAFT – CISCO CONFIDENTIAL****3.3.39 USER-LOGIN**

The Login of User (USER-LOGIN) occurs when you begin a new session by verifying your user ID and password.

This transient condition does not result in a standing condition.

**3.3.40 USER-LOGOUT**

The Logout of User (USER-LOGOUT) condition occurs when you stop a login session by logging out of your account.

This transient condition does not result in a standing condition.

**3.3.41 WKSWBK**

The Switched Back to Working (WKSWBK) condition occurs when traffic switches back to the working port or card in a nonrevertive protection group.

This transient condition does not result in a standing condition.

**3.3.42 WKSWPR**

The Switched to Protection (WKSWPR) condition occurs when traffic switches to the protect port or card in a nonrevertive protection group.

This transient condition does not result in a standing condition.

**3.3.43 WRMRESTART**

The Warm Restart (WRMRESTART) condition occurs when the node restarts while it is powered up. A restart can be caused by provisioning, such as a database restore or IP changes, or by software defects. A WRMRESTART is normally accompanied by MANRESET or AUTORESET to indicate whether the reset was initiated manually (MAN) or automatically (AUTO).

This is the first condition that appears after a TCC2/TCC2P card is powered up. The condition changes to COLD-START if the TCC2/TCC2P card is restarted from a physical reseal or a power loss.

**3.3.44 WTR-SPAN**

The Span is in Wait To Restore State (WTR-SPAN) condition occurs when a BLSR or MS-SPRing switches to another span due to a Signal Failure-Span command or a fiber is pulled from a four-fiber BLSR/MS-SPRing configuration. The condition is raised until the WaitToRestore (WTR) period expires.

This transient condition clears when the BLSR/MS-SPRing returns to a normal condition or the IDLE state.



# CHAPTER 4

## Error Messages



### Note

The terms "Unidirectional Path Switched Ring" and "UPSR" may appear in Cisco literature. These terms do not refer to using Cisco ONS 15xxx products in a unidirectional path switched ring configuration. Rather, these terms, as well as "Path Protected Mesh Network" and "PPMN," refer generally to Cisco's path protection feature, which may be used in any topological network configuration. Cisco does not recommend using its path protection feature in any particular topological network configuration.

This chapter lists the error messages for the Cisco ONS 15454 Multi-Service Transport Platform (MSTP). The error dialog box in [Figure 4-1](#) consists of three parts: the error title, error ID, and error message.

**Figure 4-1** Error Dialog Box

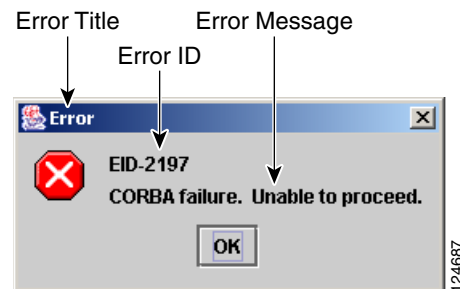

[Table 4-1](#) gives a list of all error or warning message numbers, the messages, and a brief description of each message. The table lists two types of messages: error messages (EID-*nnnn*) and warning messages (WID-*nnnn*). Error messages are alerts that an unexpected or undesirable operation has occurred that either indicates the risk of loss of traffic or an inability to properly manage devices in the network. Warnings are alerts that the requested operation could lead to an error. Warnings are sometimes used to convey important information.

Table 4-1 Error Messages

| Error/Warning ID | Error/Warning Message                                                                                                                                                                                                                                                               | Description                                                                                                                             |
|------------------|-------------------------------------------------------------------------------------------------------------------------------------------------------------------------------------------------------------------------------------------------------------------------------------|-----------------------------------------------------------------------------------------------------------------------------------------|
| EID-0            | Invalid error ID.                                                                                                                                                                                                                                                                   | The error ID is invalid.                                                                                                                |
| EID-1            | A null pointer encountered in {0}.                                                                                                                                                                                                                                                  | Cisco Transport Controller (CTC) encountered a null pointer in the area described by the specified item.                                |
| EID-1000         | The host name of the network element cannot be resolved to an address.                                                                                                                                                                                                              | Refer to the error message text.                                                                                                        |
| EID-1001         | Unable to launch CTC due to applet security restrictions.<br>Please review the installation instructions to make sure that the CTC launcher is given the permissions it needs.<br>Note that you must exit and restart your browser in order for the new permissions to take effect. | Refer to the error message text.                                                                                                        |
| EID-1002         | The host name (e.g., for the network element) was successfully resolved to its address, but no route can be found through the network to reach the address.                                                                                                                         | The node is not reachable from CTC client station.                                                                                      |
| EID-1003         | An error was encountered while attempting to launch CTC.<br>{0}                                                                                                                                                                                                                     | Unexpected exception or error while launching CTC from the applet.                                                                      |
| EID-1004         | Problem Deleting CTC Cache: {0} {1}                                                                                                                                                                                                                                                 | Unable to delete the CTC cached JARs, because another application may have the JAR files running; for example, another instance of CTC. |
| EID-1005         | An error occurred while writing to the {0} file.                                                                                                                                                                                                                                    | CTC encountered an error while writing to log files, preference files, etc.                                                             |
| EID-1006         | The URL used to download {0} is malformed.                                                                                                                                                                                                                                          | The URL used to download the specified JAR file is incorrect.                                                                           |
| EID-1007         | An I/O error occurred while trying to download {0}.                                                                                                                                                                                                                                 | An input or output exception was encountered when CTC tried to download the specified JAR file.                                         |
| EID-1018         | Password shall not contain the associated user-ID.                                                                                                                                                                                                                                  | The password is invalid.                                                                                                                |
| EID-1019         | Could not create {0}.<br>Please enter another filename.                                                                                                                                                                                                                             | CTC could not create the file due to an invalid filename.                                                                               |
| EID-1020         | Fatal exception occurred, exiting CTC.<br>Unable to switch to the Network view.                                                                                                                                                                                                     | CTC was unable to switch from the node or card view to the network view and is now shutting down.                                       |
| EID-1021         | Unable to navigate to {0}.                                                                                                                                                                                                                                                          | CTC was unable to display the requested view (node or network).                                                                         |
| EID-1022         | An IOS session cannot be opened right now with this slot. Most likely someone else (using a different CTC) already has a session opened with this slot. Please try again later.                                                                                                     | Refer to the error message text.<br>Ensure that the shell access in CTC (Provisioning>Security>Access) is set to non-secure mode.       |



**Table 4-1** Error Messages (continued)

| <b>Error/Warning ID</b> | <b>Error/Warning Message</b>                                                                                                                                                                                                                       | <b>Description</b>                                                                                                             |
|-------------------------|----------------------------------------------------------------------------------------------------------------------------------------------------------------------------------------------------------------------------------------------------|--------------------------------------------------------------------------------------------------------------------------------|
| EID-1023                | This IOS session has been terminated. Terminations are caused when the session has timed out, the card resets, there is already a session with the slot, or password configuration is required.                                                    | Refer to the error message text.                                                                                               |
| EID-1025                | Unable to create Help Broker.                                                                                                                                                                                                                      | CTC was unable to create the help broker for the online help.                                                                  |
| EID-1026                | Error found in the Help Set file.                                                                                                                                                                                                                  | CTC encountered an error in the online help file.                                                                              |
| EID-1027                | Unable to locate help content for Help ID: "{0}".                                                                                                                                                                                                  | CTC was unable to locate the content for the help ID.                                                                          |
| EID-1028                | Error saving table. {0}                                                                                                                                                                                                                            | There was an error while saving the specified table.                                                                           |
| EID-1031                | CTC cannot locate the online user manual files. The files may have been moved, deleted, or not installed. To install online user manuals, run the CTC installation wizard on the software or documentation CD.                                     | Refer to the error message text.                                                                                               |
| EID-1032                | CTC cannot locate Acrobat Reader. If Acrobat Reader is not installed, you can install the Reader using the CTC installation wizard provided on the software or documentation CD.                                                                   | Refer to the error message text.                                                                                               |
| EID-1035                | CTC experienced an I/O error while working with the log files. Usually this means that the computer has run out of disk space. This problem may or may not cause CTC to stop responding. Ending this CTC session is recommended, but not required. | Refer to the error message text.                                                                                               |
| WID-1036                | WARNING: Deleting the CTC cache may cause any CTC running on this system to behave in an unexpected manner.                                                                                                                                        | Refer to the warning message text.                                                                                             |
| EID-1037                | Could not open {0}. Please enter another filename.                                                                                                                                                                                                 | Invalid file name. CTC is unable to open the specified file. Ensure that the file exists and the filename was typed correctly. |
| EID-1038                | The file {0} does not exist.                                                                                                                                                                                                                       | The specified file does not exist.                                                                                             |
| EID-1039                | The version of the browser applet does not match the version required by the network element. Please close and restart your browser in order to launch the Cisco Transport Controller.                                                             | Refer to the error message text.                                                                                               |
| WID-1041                | An error occurred while closing the {0} connection.                                                                                                                                                                                                | CTC encountered an error while closing the specified connection.                                                               |
| WID-1042                | You have selected Java version {0}. This version is outside of the recommended range and may cause an unpredictable behavior of the software. Do you wish to continue?                                                                             | Refer to the warning message text.                                                                                             |
| EID-1043                | Error writing to file: {0}. This might be caused by a directory permission, quota or disk volume full issue.                                                                                                                                       | Check for possible causes and try again.                                                                                       |

Table 4-1 Error Messages (continued)

| Error/Warning ID | Error/Warning Message                                                                                                                                                                                                                                                         | Description                                                                                                                                                                                   |
|------------------|-------------------------------------------------------------------------------------------------------------------------------------------------------------------------------------------------------------------------------------------------------------------------------|-----------------------------------------------------------------------------------------------------------------------------------------------------------------------------------------------|
| WID-1044         | Warning: there is a discrepancy in the build timestamp between the NE cached jar file ({0}) and the NE ({1}).<br>Your CTC jar cache should be emptied.                                                                                                                        | Refer to the warning message text.                                                                                                                                                            |
| EID-1046         | Selected CTC version ({0}) must be greater than or equal to the login NE version ({1}).                                                                                                                                                                                       | The CTC software version must be greater than or equal to the software version on the node being managed.                                                                                     |
| EID-1047         | No additional Pseudo IOS windows may be opened at this time. The maximum number of Pseudo IOS windows are open.                                                                                                                                                               | Refer to the error message text.                                                                                                                                                              |
| EID-1048         | This Pseudo IOS connection has been terminated. Terminations are caused when the session has timed out, the node resets, or when the exit command has been invoked.<br><br>This may also occur when the maximum number of concurrent Pseudo IOS connections has been reached. | Refer to the error message text.                                                                                                                                                              |
| EID-1049         | A Pseudo IOS connection cannot be opened right now on this node.<br>Please try again later.                                                                                                                                                                                   | Refer to the error message text.                                                                                                                                                              |
| EID-2001         | No rolls were selected. {0}                                                                                                                                                                                                                                                   | No rolls were selected for the bridge and roll.                                                                                                                                               |
| EID-2002         | The roll must be completed or canceled before it can be deleted.                                                                                                                                                                                                              | You cannot delete the roll unless it has been completed or cancelled.                                                                                                                         |
| EID-2003         | An error occurred while deleting the roll.<br>{0}                                                                                                                                                                                                                             | There was an error when CTC tried to delete the roll.                                                                                                                                         |
| EID-2004         | No Cisco IOS slot was selected.                                                                                                                                                                                                                                               | You did not select a Cisco IOS slot.                                                                                                                                                          |
| EID-2005         | CTC cannot find the online help files for {0}. The files might have been moved, deleted, or not installed. To install online help, run the setup program on the software CD.                                                                                                  | CTC cannot find the online help files for the specified window. The files might have been moved, deleted, or not installed. To install online help, run the setup program on the software CD. |
| EID-2006         | An error occurred while editing the circuit(s).<br>{0}<br>{1}.                                                                                                                                                                                                                | An error occurred when CTC tried to open the circuit for editing.                                                                                                                             |
| EID-2007         | The preferences could not be saved.                                                                                                                                                                                                                                           | CTC cannot save the preferences.                                                                                                                                                              |
| EID-2008         | The circuit preferences could not be saved:<br>{0}                                                                                                                                                                                                                            | CTC cannot find the file needed to save the circuit preferences.                                                                                                                              |
| EID-2009         | CTC was unable to download the package:<br>{0}                                                                                                                                                                                                                                | Refer to the error message text.                                                                                                                                                              |
| EID-2010         | An error occurred while deleting the destination.                                                                                                                                                                                                                             | CTC could not delete the destination.                                                                                                                                                         |
| EID-2011         | The circuit could not be destroyed.                                                                                                                                                                                                                                           | CTC could not destroy the circuit.                                                                                                                                                            |
| EID-2012         | The reverse circuit could not be destroyed.                                                                                                                                                                                                                                   | CTC could not reverse the circuit destroy.                                                                                                                                                    |

**Table 4-1** Error Messages (continued)

| <b>Error/Warning ID</b> | <b>Error/Warning Message</b>                                                                                                                                                                   | <b>Description</b>                                                                                                                                                                                                                                                                                                                                                                                        |
|-------------------------|------------------------------------------------------------------------------------------------------------------------------------------------------------------------------------------------|-----------------------------------------------------------------------------------------------------------------------------------------------------------------------------------------------------------------------------------------------------------------------------------------------------------------------------------------------------------------------------------------------------------|
| EID-2013                | The circuit creation failed.<br>The circuit creation cannot proceed due to changes in the network which affected the circuit(s) being created.<br>The dialog box will close. Please try again. | Refer to the error message text.                                                                                                                                                                                                                                                                                                                                                                          |
| EID-2014                | No circuit(s) were selected.<br>{0}                                                                                                                                                            | You must select a circuit to complete this function.                                                                                                                                                                                                                                                                                                                                                      |
| EID-2015                | The circuit {0} cannot be deleted because it has one or more rolls.                                                                                                                            | You must delete the rolls in the circuit before deleting the circuit itself.                                                                                                                                                                                                                                                                                                                              |
| EID-2016                | The circuit deletion failed.                                                                                                                                                                   | CTC could not delete the tunnel as there are circuits that use the tunnel.                                                                                                                                                                                                                                                                                                                                |
| EID-2017                | An error occurred while mapping the circuit.<br>{0}                                                                                                                                            | There was an error mapping the circuit.                                                                                                                                                                                                                                                                                                                                                                   |
| EID-2018                | The circuit roll failed.<br>The circuit must be in the DISCOVERED state in order to perform a roll.                                                                                            | There was a failure in circuit roll. Change the circuit state to DISCOVERED and proceed.                                                                                                                                                                                                                                                                                                                  |
| EID-2019                | The circuit roll failed.<br>Bridge and roll is not supported on DWDM circuits.                                                                                                                 | Refer to the error message text.                                                                                                                                                                                                                                                                                                                                                                          |
| EID-2020                | The circuit roll failed.<br>The two circuits must have the same direction.                                                                                                                     | Refer to the error message text.                                                                                                                                                                                                                                                                                                                                                                          |
| EID-2021                | The circuit roll failed.<br>The two circuits must have the same size.                                                                                                                          | Refer to the error message text.                                                                                                                                                                                                                                                                                                                                                                          |
| EID-2022                | The circuit roll failed.<br>A maximum of two circuits can be selected for a bridge and roll operation.                                                                                         | Refer to the error message text.                                                                                                                                                                                                                                                                                                                                                                          |
| EID-2023                | CTC was unable to create a new user account.                                                                                                                                                   | Refer to the error message text.                                                                                                                                                                                                                                                                                                                                                                          |
| EID-2024                | An error occurred during node selection.                                                                                                                                                       | There was an error during node selection.                                                                                                                                                                                                                                                                                                                                                                 |
| EID-2025                | This feature cannot be used. Verify that each endpoint of this circuit is running software that supports this feature.                                                                         | Refer to the error or warning message text. For example, this error is generated from the node view Provisioning> WDM-ANS> tabs to indicate that the selected ring type is not supported by the endpoints of the circuit. Another example is the Provisioning> VLAN tabs in card view (Ethernet card only), where it indicates that the back-end spanning tree protocol (STP) disabling is not supported. |
| EID-2026                | The {0} request could not be applied.<br>{1}                                                                                                                                                   | Error occurred while attempting to switch a path protection circuit away from a span.                                                                                                                                                                                                                                                                                                                     |
| EID-2027                | An error occurred while deleting the circuit drop.                                                                                                                                             | CTC could not delete the circuit drop.                                                                                                                                                                                                                                                                                                                                                                    |
| EID-2028                | An error occurred while removing the circuit node.                                                                                                                                             | CTC could not remove the circuit node.                                                                                                                                                                                                                                                                                                                                                                    |
| EID-2029                | The requested operation is not supported.                                                                                                                                                      | The task you are trying to complete is not supported by CTC.                                                                                                                                                                                                                                                                                                                                              |

Table 4-1 Error Messages (continued)

| Error/Warning ID | Error/Warning Message                                                                                                                                                               | Description                                                                                                                                                                                                    |
|------------------|-------------------------------------------------------------------------------------------------------------------------------------------------------------------------------------|----------------------------------------------------------------------------------------------------------------------------------------------------------------------------------------------------------------|
| EID-2030         | An error occurred during provisioning.                                                                                                                                              | There was an error during provisioning.                                                                                                                                                                        |
| EID-2031         | An error occurred while adding the node.                                                                                                                                            | There was an error while adding a node.                                                                                                                                                                        |
| EID-2032         | The circuit could not be renamed.<br>{0}                                                                                                                                            | CTC could not rename the circuit.                                                                                                                                                                              |
| EID-2033         | An error occurred during validation.<br>{0}                                                                                                                                         | There was an internal error while validating the user changes after the Apply button was pressed. This error can occur in the Edit Circuit dialog box or in the BLSR table in the shelf view (rare condition). |
| EID-2034         | Network circuits could not be added:<br>{0}                                                                                                                                         | Refer to the error message text.                                                                                                                                                                               |
| EID-2035         | The source and destination nodes are not connected.                                                                                                                                 | Refer to the error message text.                                                                                                                                                                               |
| EID-2036         | The {0} cannot be deleted.<br>LAN Access has been disabled on this node and this {0} is needed to access the node.                                                                  | You cannot delete the DCC/GCC link as it is needed to access the node.                                                                                                                                         |
| EID-2037         | The attribute for {0} cannot be found.                                                                                                                                              | CTC cannot find an attribute for the specified item.                                                                                                                                                           |
| EID-2038         | The protection operation is invalid.                                                                                                                                                | The protection operation you tried to execute is invalid.                                                                                                                                                      |
| EID-2040         | Please select a node first.                                                                                                                                                         | You must select a node before performing the task.                                                                                                                                                             |
| EID-2041         | No paths are available on this link. Please make another selection.                                                                                                                 | You must select a link that has paths available.                                                                                                                                                               |
| EID-2042         | This span is not selectable. Only the green spans with an arrow may be selected.                                                                                                    | Refer to the error message text.                                                                                                                                                                               |
| EID-2043         | This node is not selectable. Only the source node and nodes attached to included spans (blue) are selectable. Selecting a selectable node will enable its available outgoing spans. | Refer to the error message text.                                                                                                                                                                               |
| EID-2044         | This link may not be included in the required list. Constraints only apply to the primary path. Each node may have a maximum of one incoming signal and one outgoing link.          | You must select only one link going in and out of a node. Selecting more than one link is contradictory to the path selection algorithm.                                                                       |
| EID-2045         | This link may not be included in the required list. Only one outgoing link may be included for each node.                                                                           | Refer to the error message text.                                                                                                                                                                               |
| EID-2047         | Please enter a valid value for the slot number.                                                                                                                                     | There was an error due to an invalid slot number.                                                                                                                                                              |
| EID-2048         | Please enter a valid value for the port number.                                                                                                                                     | There was an error due to an invalid port number.                                                                                                                                                              |
| EID-2050         | The new circuit could not be destroyed.                                                                                                                                             | CTC could not destroy the new circuit.                                                                                                                                                                         |
| EID-2051         | The circuit cannot be downgraded.<br>{0}                                                                                                                                            | The specified circuit cannot be downgraded.                                                                                                                                                                    |

Table 4-1 Error Messages (continued)

| Error/Warning ID | Error/Warning Message                                                                                                                                                                                                   | Description                                                                                                                                                                     |
|------------------|-------------------------------------------------------------------------------------------------------------------------------------------------------------------------------------------------------------------------|---------------------------------------------------------------------------------------------------------------------------------------------------------------------------------|
| EID-2052         | An error occurred during circuit processing.                                                                                                                                                                            | There was an error during the circuit processing.                                                                                                                               |
| EID-2054         | An error occurred while selecting an endpoint.                                                                                                                                                                          | There was an error during the endpoint selection.                                                                                                                               |
| EID-2055         | No endpoints are available for this selection. Please make another selection.                                                                                                                                           | This error occurs in the circuit creation dialog only during a race condition that has incorrectly allowed entities without endpoints to be displayed in the combination boxes. |
| EID-2056         | A communication error occurred: {0}                                                                                                                                                                                     | An internal error occurred in Network Alarm tab while synchronizing alarms with the nodes.                                                                                      |
| EID-2059         | An error occurred while deleting the node.<br>{0}                                                                                                                                                                       | There was an error during the node deletion.                                                                                                                                    |
| EID-2060         | No PCA circuits were found.                                                                                                                                                                                             | CTC could not find any protection channel access (PCA) circuits for this task.                                                                                                  |
| EID-2061         | An error occurred while provisioning the VLAN.                                                                                                                                                                          | There was an error defining the VLAN.                                                                                                                                           |
| EID-2062         | An error occurred while deleting VLANs.<br>No VLAN(s) were selected.<br>Please select a VLAN.                                                                                                                           | Refer to the error message text.                                                                                                                                                |
| EID-2063         | The default VLAN cannot be deleted.                                                                                                                                                                                     | The selected VLAN is the default VLAN and cannot be deleted.                                                                                                                    |
| EID-2064         | An error occurred while deleting VLANs.<br>{0}                                                                                                                                                                          | There was an error deleting the specified VLAN.                                                                                                                                 |
| EID-2065         | The profile cannot be imported.<br>The profile "{0}" exists in the editor and the maximum number of copies (ten) exists in the editor.<br>The import will be aborted. The profile has already been loaded eleven times. | Cannot import the profile because the profile has reached the maximum number of copies in the editor.                                                                           |
| EID-2066         | The profile could not be stored.<br>An error occurred while writing to {0}.                                                                                                                                             | CTC encountered an error while trying to store the profile.                                                                                                                     |
| EID-2067         | An error occurred while writing to the file.<br>{0}                                                                                                                                                                     | CTC encountered an error while writing the specified file.                                                                                                                      |
| EID-2068         | The alarm profile could not be loaded from the node.                                                                                                                                                                    | CTC encountered an error trying to load the alarm profile from the node.                                                                                                        |
| EID-2069         | The file could not be found or an I/O exception occurred.<br>{0}                                                                                                                                                        | Either the specified file was not found, or there was an input/output exception.                                                                                                |
| EID-2070         | The profile could not be deleted.<br>{0}                                                                                                                                                                                | There was a failure in deleting the specified profile.                                                                                                                          |
| EID-2071         | Only one column may be highlighted.                                                                                                                                                                                     | You cannot select more than one column during clone action.                                                                                                                     |
| EID-2072         | Only one profile may be highlighted.                                                                                                                                                                                    | You cannot select more than one profile.                                                                                                                                        |

Table 4-1 Error Messages (continued)

| Error/Warning ID | Error/Warning Message                                                                                                                                                                       | Description                                                                                                 |
|------------------|---------------------------------------------------------------------------------------------------------------------------------------------------------------------------------------------|-------------------------------------------------------------------------------------------------------------|
| EID-2073         | This column is permanent and cannot be removed.                                                                                                                                             | You cannot delete a permanent column.                                                                       |
| EID-2074         | Select one or more profiles.                                                                                                                                                                | You have not selected any profile or column. Reset operation is done by right-clicking the selected column. |
| EID-2075         | This column is permanent and cannot be reset.                                                                                                                                               | A permanent column cannot be reset.                                                                         |
| EID-2077         | This column is permanent and cannot be renamed.                                                                                                                                             | You cannot rename a permanent column.                                                                       |
| EID-2078         | At least two columns must be highlighted.                                                                                                                                                   | You cannot compare two profiles unless you select two columns.                                              |
| EID-2079         | The alarm types cannot be loaded into table.<br>There are no reachable nodes from which the list of alarm types can be loaded.<br>Please wait until such a node is reachable and try again. | Refer to the error message text.                                                                            |
| EID-2080         | The node {0} has no profiles.                                                                                                                                                               | The specified node does not have any profiles.                                                              |
| EID-2081         | An error occurred while removing profile {0} from the node {1}.                                                                                                                             | There was an error while removing the specified profile from the specified node.                            |
| EID-2082         | The profile {0} does not exist on the node {1}.                                                                                                                                             | CTC cannot find the specified profile from the specified node.                                              |
| EID-2083         | An error occurred while adding profile {0} to the node {1}.                                                                                                                                 | There was an error adding the specified profile to the specified node.                                      |
| EID-2085         | The profile selection is invalid.<br>No profiles were selected.                                                                                                                             | You tried to select an invalid profile. Select another profile.                                             |
| EID-2086         | The node selection is invalid.<br>No nodes were selected.                                                                                                                                   | You tried to select an invalid node. Select another node.                                                   |
| EID-2087         | No profiles were selected.<br>Please select at least one profile.                                                                                                                           | Refer to the error message text.                                                                            |
| EID-2088         | The profile name is invalid.                                                                                                                                                                | The profile name cannot be empty.                                                                           |
| EID-2089         | Too many copies of {0} exist. Please choose another name.                                                                                                                                   | Select a unique name.                                                                                       |
| EID-2090         | No nodes were selected.<br>Please select the node(s) on which to store the profile(s).                                                                                                      | You must select one or more nodes on which you can store the profile.                                       |
| EID-2091         | Unable to switch to the node {0}.                                                                                                                                                           | CTC is unable to switch to the specified node.                                                              |
| EID-2092         | A general exception error occurred.                                                                                                                                                         | CTC encountered a general exception error while trying to complete the task.                                |
| EID-2093         | The name is too short. It does not have enough characters.<br>{0}                                                                                                                           | The name must have a minimum of six characters.                                                             |
| EID-2094         | The password and confirmed password fields do not match.                                                                                                                                    | You must make sure the two fields have the same password.                                                   |
| EID-2095         | The password is invalid.<br>{0}                                                                                                                                                             | The password you entered is not allowed.                                                                    |

Table 4-1 Error Messages (continued)

| Error/Warning ID | Error/Warning Message                                                                                                                                                                                                 | Description                                                                                        |
|------------------|-----------------------------------------------------------------------------------------------------------------------------------------------------------------------------------------------------------------------|----------------------------------------------------------------------------------------------------|
| EID-2096         | The user must have a security level.                                                                                                                                                                                  | You must have an assigned security level to perform this task.                                     |
| EID-2097         | No user name was specified.                                                                                                                                                                                           | You did not specify a user name.                                                                   |
| EID-2099         | An error occurred while ring switching.                                                                                                                                                                               | There was an error during the ring switch.                                                         |
| EID-2100         | Please select at least one profile to delete.                                                                                                                                                                         | You have not selected the profile to delete.                                                       |
| EID-2101         | An error occurred while protection switching.                                                                                                                                                                         | There was an error during the protection switching.                                                |
| EID-2102         | The forced switch could not be removed for some circuits. You must switch these circuits manually.                                                                                                                    | The forced switch could not be removed for some circuits. You must switch these circuits manually. |
| EID-2103         | An error occurred while upgrading the span.                                                                                                                                                                           | There was an error during the span upgrade.                                                        |
| EID-2104         | The circuits cannot be switched back because one or both nodes are not reachable.                                                                                                                                     | This error occurs during the path protection span upgrade procedure.                               |
| EID-2106         | The node name cannot be empty.                                                                                                                                                                                        | You must supply a name for the node.                                                               |
| EID-2107         | An error occurred while adding {0}. The host is unknown.                                                                                                                                                              | There was an error adding the specified item.                                                      |
| EID-2108         | {0} is already in the network.                                                                                                                                                                                        | The specified item exists in the network.                                                          |
| EID-2109         | The node is already in the current login group.                                                                                                                                                                       | The node you are trying to add is already present in the current login group.                      |
| EID-2110         | Please enter a number between 0 and {0}.                                                                                                                                                                              | You must enter a number in the range between 0 and the specified value.                            |
| EID-2111         | This node ID is already in use. Please choose another.                                                                                                                                                                | Select a node ID that is not in use.                                                               |
| EID-2113         | The extension byte for the ring cannot be set.<br>{0}                                                                                                                                                                 | CTC cannot set the BLSR/MS-SPRing extension byte.                                                  |
| EID-2114         | A card communication failure occurred during the operation.                                                                                                                                                           | This error can occur during an attempt to apply a BLSR protection operation to a line.             |
| EID-2115         | An error occurred during the operation.<br>{0}                                                                                                                                                                        | There was an error in applying the specified operation.                                            |
| EID-2116         | The extension byte setting for the ring is invalid.<br>{0}                                                                                                                                                            | The extension byte set for the specified ring is invalid.                                          |
| EID-2118         | The ring cannot be deleted.<br>A protection operation is set. All protection operations must be clear for ring to be deleted.                                                                                         | Clear all the protection operations for the ring before deleting it.                               |
| EID-2119         | {0} cannot be deleted because a protection switch is in effect. Please clear any protection operations, ensure that the reversion time is not "never" and allow any protection switches to clear before trying again. | Clear all protection operations or switches before deleting the ring.                              |
| EID-2120         | The following nodes could not be unprovisioned<br>{0}<br>Therefore you will need to delete this {1} again later.                                                                                                      | The specified nodes could not be unprovisioned. Try deleting this BLSR or MS-SPRing later.         |

Table 4-1 Error Messages (continued)

| Error/Warning ID | Error/Warning Message                                                                                                                                                                                                        | Description                                                                                                                                                                                                                                                                      |
|------------------|------------------------------------------------------------------------------------------------------------------------------------------------------------------------------------------------------------------------------|----------------------------------------------------------------------------------------------------------------------------------------------------------------------------------------------------------------------------------------------------------------------------------|
| EID-2121         | The ring cannot be upgraded.<br>{0}                                                                                                                                                                                          | CTC cannot upgrade the specified ring.                                                                                                                                                                                                                                           |
| EID-2122         | The ring speed for is inadequate for the upgrade procedure. Only {0} (or higher) {1} can be upgraded to four-fiber.                                                                                                          | You have selected an incorrect ring speed for upgrade. Only rings within the specified parameters can be upgraded to 4-fiber BLSR.                                                                                                                                               |
| EID-2123         | Verify that the following nodes have at least two in-service ports with the same speed as the two-fiber {0}. The ports cannot serve as timing references, and they cannot have DCC terminations or overhead circuits.<br>{1} | Nonupgradable nodes. Verify that the specified nodes have at least two IS-NR ports with the same speed as the 2-fiber BLSR.<br>The specified ports cannot serve as a timing reference, and they cannot have data communications channel (DCC) terminations or overhead circuits. |
| EID-2124         | You cannot add this span because it is connected to a node that already has the east and west ports defined.                                                                                                                 | Refer to the error message text.                                                                                                                                                                                                                                                 |
| EID-2125         | You cannot add this span as it would cause a single card to host both the east span and the west span. A card cannot protect itself.                                                                                         | Refer to the error message text.                                                                                                                                                                                                                                                 |
| EID-2126         | An error occurred while provisioning the OSPF area.<br>{0}                                                                                                                                                                   | There is an Open Shortest Path First (OSPF) area error.                                                                                                                                                                                                                          |
| EID-2127         | You cannot add this span. It would cause the following circuit(s) to occupy different {0} regions on different spans:<br>{1}<br>Either select a different span or delete the above circuit(s).                               | A circuit cannot occupy different STS regions on different spans. You may add a different span or delete the specified circuit.                                                                                                                                                  |
| EID-2128         | The state is invalid.                                                                                                                                                                                                        | An internal error occurred while trying to remove a span from a BLSR.<br><br>This alarm occurs in the network-level BLSR creation dialog box.                                                                                                                                    |
| EID-2129         | You cannot use same slot for east and west protect ports.                                                                                                                                                                    | Refer to the error message text.                                                                                                                                                                                                                                                 |
| EID-2130         | The ring ID value, {0}, is not valid. Please enter a valid number between 0 and 9999.                                                                                                                                        | Enter a ring ID value between 0 and 9999.                                                                                                                                                                                                                                        |
| EID-2131         | The reversion cannot be set to INCONSISTENT.                                                                                                                                                                                 | You must select another reversion type.                                                                                                                                                                                                                                          |
| EID-2135         | The overhead circuit preferences could not be stored:<br>{0}                                                                                                                                                                 | Input/Output error. Unable to store overhead circuit preferences.                                                                                                                                                                                                                |
| EID-2137         | An error occurred during the circuit merge.<br>{0}                                                                                                                                                                           | There was an error while merging the circuits.                                                                                                                                                                                                                                   |
| EID-2138         | Not all destinations could be deleted.<br>Please try again.                                                                                                                                                                  | Refer to the error message text.                                                                                                                                                                                                                                                 |
| EID-2139         | An error occurred while updating the destinations.                                                                                                                                                                           | There was an error in updating the circuit destinations.                                                                                                                                                                                                                         |



Table 4-1 Error Messages (continued)

| Error/Warning ID | Error/Warning Message                                                                                                                            | Description                                                                                                                                                                        |
|------------------|--------------------------------------------------------------------------------------------------------------------------------------------------|------------------------------------------------------------------------------------------------------------------------------------------------------------------------------------|
| EID-2143         | No online help version was selected.<br>The online help book cannot be deleted.                                                                  | Select the version of online help, and proceed.                                                                                                                                    |
| EID-2144         | An error occurred while deleting the online help book(s).<br>{0}                                                                                 | You cannot delete the specified online help.                                                                                                                                       |
| EID-2145         | No nodes appear to have a Cisco IOS card.                                                                                                        | Refer to error message.                                                                                                                                                            |
| EID-2146         | This is a security violation.<br>You may only logout of your own account.                                                                        | You cannot logout of an account other than your own.                                                                                                                               |
| EID-2147         | This is a security violation.<br>You may only change your own account.                                                                           | You cannot change an account other than your own.                                                                                                                                  |
| EID-2148         | This is a security violation.<br>You cannot delete the account under which you are currently logged in.                                          | You cannot delete the account you are currently logged in.                                                                                                                         |
| WID-2149         | There is no exportable content in this view.                                                                                                     | Refer to the error message text.                                                                                                                                                   |
| WID-2150         | The node {0} is not initialized.<br>Please wait and try again.                                                                                   | Wait till the specified node is initialized and try again.                                                                                                                         |
| WID-2152         | Spanning tree protection is being disabled for this circuit.                                                                                     | Refer to the warning message text.                                                                                                                                                 |
| WID-2153         | Adding this drop will make the circuit a PCA circuit.                                                                                            | Refer to the warning message text.                                                                                                                                                 |
| WID-2154         | Monitor circuits cannot be created on a port grouping circuit.                                                                                   | Refer to the warning message text.                                                                                                                                                 |
| WID-2155         | Switch counts might not be fully supported on some nodes.<br>{0}                                                                                 | The specified nodes do not support switch counts completely.                                                                                                                       |
| WID-2156         | The manual roll mode is recommended for dual rolls.<br>For auto dual rolls, please verify that roll to facilities are in service and error-free. | Refer to the warning message text.                                                                                                                                                 |
| WID-2157         | The roll(s) cannot be completed.<br>{0}                                                                                                          | CTC could not complete the roll because the roll is destroyed, in an incomplete state, in a TL1_roll state, is cancelled, or is not ready to complete.                             |
| EID-2158         | The roll mode is invalid.<br>{0}                                                                                                                 | There are two roll modes: auto and manual. For a one-way circuit source roll, the roll mode must be auto and for a one-way circuit destination roll, the roll mode must be manual. |
| EID-2159         | The roll is not ready for completion.<br>{0}                                                                                                     | The roll is not ready for completion.                                                                                                                                              |
| EID-2160         | The roll is not connected.<br>{0}                                                                                                                | Refer to error message text.                                                                                                                                                       |

Table 4-1 Error Messages (continued)

| Error/Warning ID | Error/Warning Message                                                                                                                                                         | Description                                                                                                                                                                                                                                                                              |
|------------------|-------------------------------------------------------------------------------------------------------------------------------------------------------------------------------|------------------------------------------------------------------------------------------------------------------------------------------------------------------------------------------------------------------------------------------------------------------------------------------|
| EID-2161         | The sibling roll is not complete.<br>{0}                                                                                                                                      | One of the rolls is not completed for the dual roll. If it is auto roll, it will be completed when a valid signal is detected. If it is a manual roll, you must complete the roll from CTC if Bridge and Roll is operated from CTC, or from TL1 if Bridge and Roll is operated from TL1. |
| EID-2162         | An error occurred during roll acknowledgement.<br>{0}                                                                                                                         | Refer to the error message text.                                                                                                                                                                                                                                                         |
| EID-2163         | The roll cannot be canceled.<br>{0}                                                                                                                                           | CTC cannot cancel the roll.                                                                                                                                                                                                                                                              |
| EID-2164         | An error occurred during the roll.<br>{0}                                                                                                                                     | CTC encountered a roll error.                                                                                                                                                                                                                                                            |
| WID-2165         | The MAC address of the node {0} has been changed. All circuits originating from or dropping at this node will need to be repaired.                                            | Repair the circuits that originate from or drop at the specified node, with the new MAC address.                                                                                                                                                                                         |
| WID-2166         | The node cannot be inserted into the domain because it is not initialized.                                                                                                    | Initialize the node and proceed.                                                                                                                                                                                                                                                         |
| WID-2167         | You have insufficient security privileges to perform this action.                                                                                                             | You do not have the privilege to perform this action.                                                                                                                                                                                                                                    |
| WID-2168         | The following warnings surfaced while loading {0}.<br>{1}                                                                                                                     | CTC encountered warnings while loading the alarm profile import file.                                                                                                                                                                                                                    |
| WID-2169         | One or more of the profiles selected do not exist on one or more of the nodes selected.                                                                                       | The profile selected does not exist on the node. Select another profile.                                                                                                                                                                                                                 |
| WID-2170         | The profile list on node {0} is full. Please delete one or more profiles if you wish to add the profile.<br>{1}                                                               | The number of profile that can exist on a node has reached the limit. To add a profile, delete any of the existing profiles.                                                                                                                                                             |
| WID-2171         | You have been logged out. Click OK to exit CTC.                                                                                                                               | Refer to the warning message text.                                                                                                                                                                                                                                                       |
| WID-2172         | The CTC CORBA (IIOP) listener port setting of {0} will be applied on the next CTC restart.                                                                                    | The Internet Inter-ORB Protocol (IIOP) listener port setting for the CTC Common Object Request Broker Architecture (CORBA) will be applied on the next CTC restart.                                                                                                                      |
| EID-2173         | The port is unavailable.<br>The desired CTC CORBA ({0}) listener port, {1}, is already in use or you do not have permission to listen on it. Please select an alternate port. | Select an alternate port, as the current port is either in use or you do not have enough permission on it.                                                                                                                                                                               |
| EID-2174         | An invalid number was entered. Please check it and try again.                                                                                                                 | You entered an invalid firewall port number. Try again.                                                                                                                                                                                                                                  |
| WID-2175         | An extension byte mismatch occurred.<br>{0}                                                                                                                                   | There is a mismatch with the extension byte.                                                                                                                                                                                                                                             |

**Table 4-1** Error Messages (continued)

| <b>Error/Warning ID</b> | <b>Error/Warning Message</b>                                                                                                                                                                                                                    | <b>Description</b>                                                                                                                                            |
|-------------------------|-------------------------------------------------------------------------------------------------------------------------------------------------------------------------------------------------------------------------------------------------|---------------------------------------------------------------------------------------------------------------------------------------------------------------|
| WID-2176                | Not all spans have the same OSPF area ID.<br>This will cause problems with protection switching. To determine the OSPF area for a given span, click on the span and the OSPF area will be displayed in the pane to the left of the network map. | Refer to the warning message text.                                                                                                                            |
| WID-2178                | Only one edit pane can be opened at a time. The existing pane will be displayed.                                                                                                                                                                | Refer to the warning message text.                                                                                                                            |
| WID-2179                | No update is available because the circuit has been deleted.                                                                                                                                                                                    | Refer to the warning message text.                                                                                                                            |
| EID-2180                | The CTC initialization failed during step {0}.                                                                                                                                                                                                  | CTC initialization has failed in the specified step.                                                                                                          |
| EID-2181                | This link cannot be included because it originates from the destination.                                                                                                                                                                        | You must not include this link as it originates from destination of a circuit. It is against the path selection algorithm.                                    |
| EID-2182                | The value of {0} is invalid.                                                                                                                                                                                                                    | The value of the specified item is invalid.                                                                                                                   |
| EID-2183                | The circuit roll failed.<br>Bridge and roll is not supported on VCAT circuits.                                                                                                                                                                  | Refer to the error message text.                                                                                                                              |
| EID-2184                | Spanning Tree Protocol cannot be enabled on some ports because the ports have been assigned an incompatible list of VLANs.<br>You can view the VLAN/Spanning Tree table or reassign the Ethernet port VLANs.                                    | Refer to the error message text.                                                                                                                              |
| EID-2185                | The VLANs on some ports cannot be assigned because they are incompatible with the Spanning Tree Protocol.<br>You can view the VLAN/Spanning Tree table or reassign the VLANs.                                                                   | Refer to the error message text.                                                                                                                              |
| EID-2186                | The software download failed on node {0}.                                                                                                                                                                                                       | The software could not be downloaded onto the specified node.                                                                                                 |
| EID-2187                | The ring name cannot exceed {0} characters.<br>Please try again.                                                                                                                                                                                | You must shorten the length of the ring name.                                                                                                                 |
| EID-2188                | The nodes in this ring do not support alphanumeric IDs. Please use a ring ID between {0} and {1}.                                                                                                                                               | The ring ID should not contain alphanumeric characters, and must be in the specified range.                                                                   |
| EID-2189                | The TL1 keyword "all" cannot be used as the ring name.<br>Please provide another name.                                                                                                                                                          | Refer to the error message text.                                                                                                                              |
| EID-2190                | Adding this span will cause the ring to contain more nodes than allowed.                                                                                                                                                                        | You have reached the maximum number of nodes allowed.                                                                                                         |
| EID-2191                | The ring name must not be empty.                                                                                                                                                                                                                | You must supply a ring name.                                                                                                                                  |
| EID-2192                | A valid route cannot be found for the circuit creation request.                                                                                                                                                                                 | CTC could not complete the circuit creation request either because there are no physical links, or the bandwidth of the available links are already reserved. |

Table 4-1 Error Messages (continued)

| Error/Warning ID | Error/Warning Message                                                                                                                                                                                                                                                | Description                                                                                    |
|------------------|----------------------------------------------------------------------------------------------------------------------------------------------------------------------------------------------------------------------------------------------------------------------|------------------------------------------------------------------------------------------------|
| EID-2193         | A valid route cannot be found for the circuit drop creation request.                                                                                                                                                                                                 | Refer to the error message text.                                                               |
| EID-2194         | A valid route cannot be found for the roll creation request.                                                                                                                                                                                                         | Refer to the error message text.                                                               |
| EID-2195         | The circuit VLAN list cannot be mapped to one spanning tree. You can view the VLAN/Spanning Tree table or reassign VLANs.                                                                                                                                            | Refer to the error message text.                                                               |
| EID-2196         | CTC cannot be relaunched.<br>{0}                                                                                                                                                                                                                                     | There is an error relaunching CTC.                                                             |
| EID-2197         | A CORBA failure occurred. CTC cannot proceed.                                                                                                                                                                                                                        | There was a CORBA failure, and the task cannot proceed. Verify the Java version.               |
| EID-2198         | CTC is unable to switch to the {0} view.                                                                                                                                                                                                                             | CTC is unable to switch to the specified view.                                                 |
| EID-2199         | Login failed on {0} {1}                                                                                                                                                                                                                                              | The login failed on the specified tasks.                                                       |
| EID-2200         | CTC has detected a jar file deletion. The jar file was used to manage one or more nodes. This CTC session will not be able to manage those nodes and they will appear gray on the network map. It is recommended that you exit this CTC session and start a new one. | Refer to the error message text.                                                               |
| EID-2202         | An intra-node DRI circuit must have two sources.                                                                                                                                                                                                                     | Intranode circuit must have two sources to be a dual ring interconnect (DRI).                  |
| EID-2203         | No member was selected.                                                                                                                                                                                                                                              | You must select a member.                                                                      |
| EID-2204         | The number of circuits must be a positive integer.                                                                                                                                                                                                                   | The number of circuits cannot be zero or negative.                                             |
| EID-2205         | The circuit type must be selected.                                                                                                                                                                                                                                   | You must select a circuit type.                                                                |
| EID-2206         | The profile cannot be autoselected. Please select profile(s) to store and try again.                                                                                                                                                                                 | Refer to the error message text.                                                               |
| EID-2207         | You cannot add this span. Either the ring name is too long (that is, ring name length is greater than {0}) or the endpoints do not support alphanumeric IDs.                                                                                                         | Reduce the length of the ring name, or remove the alphanumeric characters from the end points. |
| EID-2208         | This is an invalid or unsupported JRE.                                                                                                                                                                                                                               | The version of Java Runtime Environment (JRE) is either invalid or unsupported.                |
| EID-2209         | The user name must be at least {0} characters long.                                                                                                                                                                                                                  | The user name must be at least of the specified character length.                              |
| EID-2210         | No package name was selected.                                                                                                                                                                                                                                        | You must select a package name.                                                                |
| EID-2211         | No node was selected for upgrade.                                                                                                                                                                                                                                    | You must select a node for the upgrade.                                                        |
| EID-2212         | A protected line is not provisionable.                                                                                                                                                                                                                               | The protected line cannot be provisioned. Choose another line.                                 |
| WID-2213         | The current type or state of some drops does not allow the new circuit state of {0} to be applied to them indirectly.                                                                                                                                                | The circuit state, specified by {0} cannot be applied to the selected drops.                   |
| EID-2214         | The node is disconnected. Please wait until the node reconnects.                                                                                                                                                                                                     | Refer to the error message text.                                                               |

**Table 4-1** Error Messages (continued)

| <b>Error/Warning ID</b> | <b>Error/Warning Message</b>                                                                                                          | <b>Description</b>                                                                                              |
|-------------------------|---------------------------------------------------------------------------------------------------------------------------------------|-----------------------------------------------------------------------------------------------------------------|
| EID-2215                | An error occurred while leaving the {0} page.                                                                                         | There was an error while leaving the specified page.                                                            |
| EID-2216                | An error occurred while entering the {0} page.                                                                                        | There was an error while entering the specified page.                                                           |
| EID-2217                | Some conditions could not be retrieved from the network view                                                                          | Refer to the error message text.                                                                                |
| EID-2218                | The bandwidth must be between {0} and {1} percent.                                                                                    | The bandwidth must be within the specified parameters.                                                          |
| EID-2219                | The protection operation failed. An XC loopback was applied on the cross-connection.                                                  | As the protection operation failed, a cross-connect (XC) loopback will be applied on cross-connection.          |
| EID-2220                | The tunnel status is PARTIAL. CTC is not able to change it. Please try again later.                                                   | Refer to the error message text.                                                                                |
| EID-2221                | A valid route cannot be found for the unprotected to {0} upgrade request.                                                             | Refer to the error message text.                                                                                |
| EID-2222                | One or more of the following nodes are currently part of a four-fiber {0}. Only a single four-fiber {0} is supported per node.<br>{1} | The nodes, specified by {1}, are already part of a 4-fiber BLSR/MS-SPRing type (specified by {0}).              |
| EID-2223                | Only one circuit can be upgraded at a time.                                                                                           | Refer to the error message text.                                                                                |
| EID-2224                | This link may not be included because it terminates on the source.                                                                    | Refer to the error message text.                                                                                |
| EID-2225                | A valid signal could not be detected while trying to complete the roll.<br>{0}                                                        | Roll can be completed only when a valid signal is detected. If not, the roll completion may result in an error. |
| EID-2226                | The circuit roll failed.<br>{0}                                                                                                       | Refer to the error message text.                                                                                |
| EID-2320                | This VCAT circuit does not support deletion of its member circuits.                                                                   | You can not delete a circuit that is a member of VCAT circuit.                                                  |
| EID-2321                | An error occurred while deleting member circuits.<br>{0}                                                                              | Refer to the error message text.                                                                                |
| WID-2322                | Not all cross-connects from selected circuits could be merged into the current circuit. They might appear as partial circuits.        | Refer to the warning message text.                                                                              |
| EID-2323                | The circuit roll failed.<br>Bridge and roll is not supported on monitor circuits.                                                     | A monitor circuit does not support Bridge and Roll.                                                             |
| EID-2324                | An error occurred during the circuit upgrade.<br>{0}                                                                                  | Refer to the error message text.                                                                                |
| EID-2325                | You have failed {0} times to unlock this session. CTC will exit after you click OK or close this dialog box.                          | The maximum amount of attempts to unlock this session has been reached.                                         |

Table 4-1 Error Messages (continued)

| Error/Warning ID | Error/Warning Message                                                                                                                                                                                                                                                    | Description                                                                                                            |
|------------------|--------------------------------------------------------------------------------------------------------------------------------------------------------------------------------------------------------------------------------------------------------------------------|------------------------------------------------------------------------------------------------------------------------|
| WID-2326         | Currently, CTC does not support bridge and roll on circuits that are entirely created by TL1. To continue with bridge and roll in CTC, the selected circuits must be upgraded.<br>Is it OK to upgrade the selected circuits and continue the bridge and roll operation?  | Refer to the warning message text.                                                                                     |
| WID-2327         | Currently, CTC does not support bridge and roll on circuits that are partially created by TL1. To continue with bridge and roll in CTC, the selected circuits must be upgraded.<br>Is it OK to upgrade the selected circuits and continue the bridge and roll operation? | Refer to the warning message text.                                                                                     |
| EID-2328         | An error occurred during the circuit reconfiguration.<br>{0}                                                                                                                                                                                                             | The attempt to reconfigure the specified circuit has failed.                                                           |
| EID-2329         | {0} of {1} circuits could not be successfully created.                                                                                                                                                                                                                   | A few circuits could not be created.                                                                                   |
| EID-2330         | An error occurred during circuit verification. The selected {0} is invalid!<br>{1}                                                                                                                                                                                       | The selected item, specified by {0}, is invalid as per the details, specified in {1}.                                  |
| EID-2331         | Deleting {0} might be service affecting.                                                                                                                                                                                                                                 | Deleting the item can affect the service of CTC.                                                                       |
| EID-2332         | A validation error occurred in row {0}.<br>{1} hold-off timer for {2} must be between {3}-10,000 ms, in steps of 100 ms.                                                                                                                                                 | Refer to the error message text.                                                                                       |
| EID-2333         | The SSLIOP port cannot have the same port value as IIOP port. Please change it and apply again.                                                                                                                                                                          | Refer to the error message text.                                                                                       |
| EID-3001         | An Ethernet RMON threshold with the same parameters already exists. Please change one or more of the parameters and try again.                                                                                                                                           | Change a few parameters in an Ethernet remote monitoring (RMON) threshold and try again.                               |
| EID-3002         | An error occurred while retrieving defaults from the node: {0}                                                                                                                                                                                                           | There was an error while retrieving the defaults from the specified node.                                              |
| EID-3003         | The file {0} cannot be loaded.                                                                                                                                                                                                                                           | CTC cannot load the specified file.                                                                                    |
| EID-3004         | Properties cannot be loaded from the node.                                                                                                                                                                                                                               | Refer to the error message text.                                                                                       |
| EID-3005         | NE update properties cannot be saved to the file {0}.                                                                                                                                                                                                                    | CTC cannot save the network element (NE) update values to the specified file.                                          |
| EID-3006         | NE update properties cannot be loaded from the node.                                                                                                                                                                                                                     | Refer to the error message text.                                                                                       |
| EID-3007         | An error occurred while provisioning the {0}.                                                                                                                                                                                                                            | There was a provisioning error for the specified item.                                                                 |
| EID-3008         | This is not a valid card.                                                                                                                                                                                                                                                | You cannot perform DWDM automatic node setup (ANS) from the Card view. Please navigate to the Node view and try again. |
| EID-3009         | No {0} was selected.                                                                                                                                                                                                                                                     | Select the specified item, for example, VLAN, port, slot, etc.                                                         |
| EID-3010         | A bidirectional optical link could not be created.                                                                                                                                                                                                                       | Refer to the error message text.                                                                                       |

Table 4-1 Error Messages (continued)

| Error/Warning ID | Error/Warning Message                                                                                                                                                     | Description                                                                                                                                                   |
|------------------|---------------------------------------------------------------------------------------------------------------------------------------------------------------------------|---------------------------------------------------------------------------------------------------------------------------------------------------------------|
| EID-3016         | The subnet address is invalid.                                                                                                                                            | Refer to the error message text.                                                                                                                              |
| EID-3017         | The subnet address already exists.                                                                                                                                        | Refer to the error message text.                                                                                                                              |
| EID-3019         | The internal subnet address is incomplete.                                                                                                                                | Enter the complete internal subnet address.                                                                                                                   |
| EID-3020         | The subnet address cannot be the same for both TSC cards.<br>The requested action is not allowed.                                                                         | A node's internal subnet must be different from one another as each TSC is on separate ethernet buses, isolated by broadcast domains.                         |
| EID-3021         | An error occurred while retrieving the diagnostics:<br>{0}                                                                                                                | Refer to the error message text.                                                                                                                              |
| EID-3022         | The requested action is not allowed.                                                                                                                                      | The requested action is not allowed.                                                                                                                          |
| EID-3023         | The low order cross-connect mode could not be retrieved.                                                                                                                  | Refer to the error message text.                                                                                                                              |
| EID-3024         | The {0} cross-connect mode could not be switched.<br>Please verify that the type and/or number of circuits provisioned does not exceed the criterion for switching modes. | CTC cannot switch the cross-connect mode for the specified item, as the type or the number of circuits does not match with the criterion for switching modes. |
| EID-3025         | An error occurred while retrieving thresholds.                                                                                                                            | There was an error retrieving the thresholds.                                                                                                                 |
| EID-3026         | The send DoNotUse attribute cannot be modified.                                                                                                                           | You cannot modify the Send DoNotUse field.                                                                                                                    |
| EID-3027         | The SyncMsg attribute cannot be modified.                                                                                                                                 | You cannot modify the SyncMsg field.                                                                                                                          |
| EID-3028         | The port type cannot be changed.                                                                                                                                          | You cannot change the port type.                                                                                                                              |
| EID-3029         | Unable to switch to the byte because an overhead change is present on this byte of the port.                                                                              | Refer to the error message text.                                                                                                                              |
| EID-3031         | An error occurred while hard-resetting the card.                                                                                                                          | There was an error while resetting card hardware.                                                                                                             |
| EID-3032         | An error occurred while resetting the card.                                                                                                                               | There was an error while resetting the card.                                                                                                                  |
| EID-3033         | The lamp test is not supported on this shelf.                                                                                                                             | Refer to the error message text.                                                                                                                              |
| EID-3035         | The cross-connect diagnostics cannot be performed                                                                                                                         | Refer to the error message text.                                                                                                                              |
| EID-3036         | The cross-connect diagnostics test is not supported on this shelf.                                                                                                        | The cross-connect diagnostics test is not supported on this shelf.                                                                                            |
| EID-3039         | An error occurred while changing the card type.                                                                                                                           | There was an error while changing the card.                                                                                                                   |
| EID-3040         | The card type is invalid.                                                                                                                                                 | The selected card type is invalid.                                                                                                                            |
| EID-3041         | An error occurred while applying changes.                                                                                                                                 | CTC is unable to create a protection group. Check if the protect port supports circuits, a timing reference, SONET SDCC, orderwire, or a test access point.   |
| EID-3042         | The flow control low value must be less than the flow control high value for all ports in the card.                                                                       | Refer to the error message text.                                                                                                                              |
| EID-3046         | The flow control watermark value must be between {0} and {1}, inclusive.                                                                                                  | The flow control watermark value must be between the two specified values.                                                                                    |

Table 4-1 Error Messages (continued)

| Error/Warning ID | Error/Warning Message                                                                                                              | Description                                                                                                          |
|------------------|------------------------------------------------------------------------------------------------------------------------------------|----------------------------------------------------------------------------------------------------------------------|
| EID-3047         | The file {0} could not be read.<br>Please verify the name and try again.                                                           | Refer to the error message text.                                                                                     |
| EID-3048         | There is no Cisco IOS startup configuration file available to download.                                                            | CTC could not find the configuration file for IOS startup.                                                           |
| EID-3049         | The download cannot be done at this time because an update in progress.                                                            | Refer to the error message text.                                                                                     |
| EID-3050         | An error occurred while trying to save the file to your local file system.                                                         | Check whether the file already exists and cannot be over written, or there is a space constraint in the file system. |
| EID-3051         | The configuration file has a maximum size of {0} bytes.                                                                            | The size of the configuration file should not exceed the specified number of bytes.                                  |
| EID-3052         | An error occurred while saving the configuration file to the TCC2/TCC2P.                                                           | Refer to the error message text.                                                                                     |
| EID-3053         | The value of {0} must be between {1} and {2}.                                                                                      | The value of the item must be between the specified values.                                                          |
| EID-3054         | The provisioned input/output ports cannot be removed or another user is updating the card. Please try to remove these ports later. | Another user may be updating the card. You can try again later.                                                      |
| EID-3055         | The soak maintenance pane cannot be created.                                                                                       | Refer to the error message text.                                                                                     |
| EID-3056         | Defaults cannot be saved to the file {0}.                                                                                          | CTC cannot save the defaults to the specified file.                                                                  |
| EID-3057         | Default properties cannot be loaded from the node.                                                                                 | Refer to the error message text.                                                                                     |
| EID-3058         | The file {0} does not exist.                                                                                                       | Refer to the error message text.                                                                                     |
| EID-3059         | An error occurred while refreshing.                                                                                                | There was an error while refreshing.                                                                                 |
| EID-3060         | The ALS recovery pulse interval must be between {0} seconds and {1} seconds.                                                       | The automatic laser shutdown (ALS) Recovery Interval must be between the specified range of seconds.                 |
| EID-3061         | The ALS recovery pulse duration must be between {0} seconds and {1} seconds.                                                       | The automatic laser shutdown (ALS) Recovery Duration must be between the specified range of seconds.                 |
| EID-3062         | An error occurred while setting values in the table.                                                                               | Refer to the error message text.                                                                                     |
| EID-3064         | This is not a G1000 card.                                                                                                          | This card is not a G1000-4 card.                                                                                     |
| EID-3065         | An error occurred while attempting to create this RMON threshold:<br>{0}                                                           | You must wait some time before you try again.                                                                        |
| EID-3066         | The sample period must be between 10 and {0}.                                                                                      | Refer to the error message text.                                                                                     |
| EID-3067         | The rising threshold must be between 1 and {0}.                                                                                    | This is an invalid rising threshold entry. The valid range is from 1 to the specified value.                         |
| EID-3068         | The falling threshold must be between 1 and {0}.                                                                                   | This is an invalid falling threshold entry. The valid range is from 1 to the specified value.                        |



**Table 4-1** Error Messages (continued)

| <b>Error/Warning ID</b> | <b>Error/Warning Message</b>                                                                                           | <b>Description</b>                                                                                                        |
|-------------------------|------------------------------------------------------------------------------------------------------------------------|---------------------------------------------------------------------------------------------------------------------------|
| EID-3069                | The rising threshold must be greater than or equal to the falling threshold.                                           | Refer to the error message text.                                                                                          |
| EID-3070                | Error in data for ports {0} Exactly one VLAN must be marked untagged for each port. These changes will not be applied. | CTC encountered data error for the specified ports. Only one VLAN should be marked untagged for each port.                |
| EID-3071                | An error occurred while retrieving the learned address list.                                                           | Unable to retrieve the learned MAC address from the NE.                                                                   |
| EID-3072                | An error occurred while clearing the learned address.                                                                  | Failure attempting to clear the learned MAC address from a specific card or Ether group.                                  |
| EID-3073                | An error occurred while clearing the selected rows.                                                                    | Failure attempting to clear the learned MAC address from a specific card or Ether group.                                  |
| EID-3074                | An error occurred while clearing the learned address list by {0}.                                                      | Error encountered trying to clear the learned MAC address from either a VLAN or a port.                                   |
| EID-3075                | At least one row in the parameter column must be selected.                                                             | Refer to the error message text.                                                                                          |
| EID-3076                | CTC lost its connection with this node. The NE Setup Wizard will exit.                                                 | Refer to the error message text.                                                                                          |
| EID-3077                | No optical link was selected.                                                                                          | Refer to the error message text.                                                                                          |
| EID-3078                | An optical link could not be created.                                                                                  | Refer to the error message text.                                                                                          |
| EID-3079                | Defaults cannot be applied to the node. {0}                                                                            | CTC cannot apply the defaults to the specified node.                                                                      |
| EID-3080                | CTC cannot navigate to the target tab. {0}                                                                             | CTC cannot go to the specified target tab.                                                                                |
| EID-3081                | The port type cannot be changed.                                                                                       | Refer to the error message text.                                                                                          |
| EID-3082                | The {0} extension byte cannot be changed.                                                                              | You cannot modify the specified extension byte.                                                                           |
| EID-3084                | An error occurred while retrieving laser parameters for {0}.                                                           | There is no card, or there was an internal communications error when attempting to get the laser parameters for the card. |
| EID-3085                | No OSC Terminations were selected                                                                                      | Select an OSC termination and proceed.                                                                                    |
| EID-3086                | One or more Osc terminations could not be created.                                                                     | Refer to the error message text.                                                                                          |
| EID-3087                | The OSC termination could not be edited.                                                                               | Refer to the error message text.                                                                                          |
| EID-3088                | No {0} card is present to switch.                                                                                      | No card of the specified type is available to switch.                                                                     |
| EID-3089                | The {0} state cannot be used or changed when the {1} has failed or is missing.                                         | You cannot use or change the specified state when the card is failed or missing.                                          |
| EID-3090                | The operation cannot be performed because the {0} is {1} LOCKED_ON/LOCKED_OUT.                                         | You cannot perform operation.                                                                                             |
| EID-3091                | The operation cannot be performed because the protect card is active.                                                  | Refer to the error message text.                                                                                          |

Table 4-1 Error Messages (continued)

| Error/Warning ID | Error/Warning Message                                                                                                                                                                                                                 | Description                                                                                                      |
|------------------|---------------------------------------------------------------------------------------------------------------------------------------------------------------------------------------------------------------------------------------|------------------------------------------------------------------------------------------------------------------|
| EID-3092         | The requested action cannot be applied because the service state is invalid.                                                                                                                                                          | Select another service state and proceed.                                                                        |
| EID-3093         | The operation cannot be performed because the duplex pair is {0}locked.                                                                                                                                                               | Refer to the error message text.                                                                                 |
| EID-3094         | The operation cannot be performed because no cross-connect redundancy is available.                                                                                                                                                   | You cannot perform the requested operation on the cross connect card without having a backup cross connect card. |
| EID-3095         | The deletion failed because the circuit is in use                                                                                                                                                                                     | Refer to the error message text.                                                                                 |
| WID-3096         | An internal communication error was encountered while retrieving laser parameters.<br>This can happen when equipment is not present or when equipment is resetting.<br>Check the equipment state and try to refresh the values again. | Refer to the warning message text.                                                                               |
| EID-3097         | The ring termination is in use.                                                                                                                                                                                                       | The ring termination you are trying to access is in use. Try after sometime.                                     |
| EID-3098         | No ring terminations were selected.                                                                                                                                                                                                   | Select one of the ring terminations.                                                                             |
| EID-3099         | The entered key does not match the existing authentication key.                                                                                                                                                                       | Check the authentication key and reenter.                                                                        |
| EID-3100         | An error occurred during authentication.                                                                                                                                                                                              | There was an error in authentication. Verify that the key does not exceed the character limit.                   |
| EID-3101         | The DCC metric must be between 1 and 65535.                                                                                                                                                                                           | The DCC metric should be in the range of 1 to 65535.                                                             |
| EID-3102         | The DCC metric is invalid.                                                                                                                                                                                                            | There was an invalid DCC metric.                                                                                 |
| EID-3103         | The IP address {0} is invalid}.                                                                                                                                                                                                       | The IP address is invalid.                                                                                       |
| EID-3104         | The router priority must be between 0 and 255.                                                                                                                                                                                        | The router priority should be in the range of 0 to 255.                                                          |
| EID-3105         | The router priority is invalid.                                                                                                                                                                                                       | The router priority is invalid.                                                                                  |
| EID-3106         | The hello interval must be between 1 and 65535.                                                                                                                                                                                       | The hello interval should be in the range of 1 to 65535.                                                         |
| EID-3107         | The hello interval is invalid.                                                                                                                                                                                                        | The hello interval is invalid.                                                                                   |
| EID-3109         | The dead interval must be between 1 and 2147483647.                                                                                                                                                                                   | The dead interval value must be between 1 and 2147483647.                                                        |
| EID-3110         | The dead interval must be larger than the hello interval.                                                                                                                                                                             | Refer to the error message text.                                                                                 |
| EID-3111         | The LAN transmit delay must be between 1 and 3600 seconds.                                                                                                                                                                            | The LAN transit delay should be in the range of 1 to 3600 seconds.                                               |
| EID-3112         | The transmit delay is invalid.                                                                                                                                                                                                        | The transmit delay is invalid.                                                                                   |
| EID-3113         | The retransmit interval must be between 1 and 3600 seconds.                                                                                                                                                                           | The retransmit interval should be in the range of 1 to 3600 seconds.                                             |
| EID-3114         | The retransmit interval is invalid.                                                                                                                                                                                                   | The retransmit interval is invalid.                                                                              |

**Table 4-1** Error Messages (continued)

| <b>Error/Warning ID</b> | <b>Error/Warning Message</b>                                                                                                                        | <b>Description</b>                                                                                                                                                                                                                                                                   |
|-------------------------|-----------------------------------------------------------------------------------------------------------------------------------------------------|--------------------------------------------------------------------------------------------------------------------------------------------------------------------------------------------------------------------------------------------------------------------------------------|
| EID-3115                | The LAN metric must be between 1 and 65535.                                                                                                         | The LAN metric should be in the range of 1 to 65535.                                                                                                                                                                                                                                 |
| EID-3116                | The LAN metric is invalid.                                                                                                                          | The LAN metric is invalid.                                                                                                                                                                                                                                                           |
| EID-3117                | If OSPF is active on the LAN, no DCC area IDs may be 0.0.0.0. Please change all DCC area IDs to non-0.0.0.0 values before enabling OSPF on the LAN. | Refer to the error message text.                                                                                                                                                                                                                                                     |
| EID-3118                | If OSPF is active on the LAN, the LAN area ID cannot be the same as the DCC area ID.                                                                | LAN must be part of a different OSPF area other than the DCC network.                                                                                                                                                                                                                |
| EID-3119                | An error occurred during validation.                                                                                                                | CTC was unable to validate the values entered by the user. This error message is common to several different provisioning tabs within CTC (examples include the SNMP provisioning tab, the General > Network provisioning tab, the Security > Configuration provisioning tab, etc.). |
| EID-3120                | No object of type {0} was selected for deletion.                                                                                                    | Choose an object of the specified type to delete.                                                                                                                                                                                                                                    |
| EID-3121                | An error occurred while deleting {0}.                                                                                                               | There is an error deleting the item.                                                                                                                                                                                                                                                 |
| EID-3122                | No object of type {0} was selected to edit.                                                                                                         | Choose an object of the specified type to edit.                                                                                                                                                                                                                                      |
| EID-3123                | An error occurred while editing {0}.                                                                                                                | There was an error editing the item.                                                                                                                                                                                                                                                 |
| EID-3124                | The {0} termination is in use. Delete the associated OSPF range table entry and try again.                                                          | Refer to the error message text.                                                                                                                                                                                                                                                     |
| EID-3125                | No {0} terminations were selected.                                                                                                                  | No specified terminations are selected.                                                                                                                                                                                                                                              |
| EID-3126                | The {0} termination could not be edited.                                                                                                            | CTC could not edit the specified termination.                                                                                                                                                                                                                                        |
| EID-3127                | Orderwire cannot be provisioned because the E2 byte is in use by {0}.                                                                               | Refer to the error message text.                                                                                                                                                                                                                                                     |
| EID-3128                | The authentication key cannot exceed {0} characters.                                                                                                | The authentication key cannot exceed the specified number of characters.                                                                                                                                                                                                             |
| EID-3129                | The authentication keys do not match!                                                                                                               | Refer to the error message text.                                                                                                                                                                                                                                                     |
| EID-3130                | An error occurred while creating the OSPF area virtual link.                                                                                        | CTC encountered an error while creating the area virtual link.                                                                                                                                                                                                                       |
| EID-3131                | An error occurred while creating the OSPF virtual link.                                                                                             | CTC encountered an error creating the virtual link.                                                                                                                                                                                                                                  |
| EID-3132                | An error occurred while setting the OSPF area range: {0}, {1}, false.                                                                               | CTC encountered an error while setting the area range for the specified values.                                                                                                                                                                                                      |
| EID-3133                | The maximum number of OSPF area ranges has been exceeded.                                                                                           | OSPF area ranges exceeded the maximum number.                                                                                                                                                                                                                                        |
| EID-3134                | The area ID is invalid. Use the DCC OSPF area ID, LAN port area ID, or 0.0.0.0.                                                                     | Refer to the error message text.                                                                                                                                                                                                                                                     |

Table 4-1 Error Messages (continued)

| Error/Warning ID | Error/Warning Message                                                                                                               | Description                                                                                             |
|------------------|-------------------------------------------------------------------------------------------------------------------------------------|---------------------------------------------------------------------------------------------------------|
| EID-3135         | The mask is invalid.                                                                                                                | Refer to the error message text.                                                                        |
| EID-3136         | The range address is invalid.                                                                                                       | The range address is invalid. Try again.                                                                |
| EID-3137         | Your request has been denied because the timing source information was updated while your changes were still pending. Please retry. | Refer to the error message text.                                                                        |
| EID-3138         | The clock source for switching is invalid.                                                                                          | You have selected an invalid clock source. Choose another clock.                                        |
| EID-3139         | A switch cannot be made to a reference of inferior quality.                                                                         | Refer to the error message text.                                                                        |
| EID-3140         | A higher priority switch is already active.                                                                                         | You cannot switch the timing source manually when a higher priority switch is already active.           |
| EID-3141         | An attempt was made to access a bad reference.                                                                                      | Refer to the error message text.                                                                        |
| EID-3142         | No switch is active.                                                                                                                | None of the switches are active.                                                                        |
| EID-3143         | An error occurred while creating the static route entry.                                                                            | CTC encountered an error while a creating static route entry.                                           |
| EID-3144         | The maximum number of static routes has been exceeded.                                                                              | The number of static routes has exceeded its limit.                                                     |
| EID-3145         | The RIP metric must be between 1 and 15.                                                                                            | The Routing Information Protocol (RIP) metric should be in the range of 1 to 15.                        |
| EID-3146         | The RIP metric is invalid.                                                                                                          | Refer to the error message text.                                                                        |
| EID-3147         | An error occurred while creating the summary address.                                                                               | There was an error while creating the summary address.                                                  |
| EID-3148         | No Layer 2 domain has been provisioned.                                                                                             | You must provision any one of the layer 2 domain.                                                       |
| EID-3149         | The MAC addresses could not be retrieved.                                                                                           | Refer to the error message text.                                                                        |
| EID-3150         | The target file {0} is not a normal file.                                                                                           | The specified target file is not a normal file.                                                         |
| EID-3151         | The target file {0} is not writable.                                                                                                | The target file is not writeable. Specify another file.                                                 |
| EID-3152         | An error occurred while creating the protection group.                                                                              | CTC encountered an error creating Protection Group.                                                     |
| EID-3153         | The card cannot be deleted because it is in use.                                                                                    | Refer to the error message text.                                                                        |
| EID-3154         | An error occurred while provisioning the card: CTC cannot {0} the card.                                                             | CTC cannot perform the task on the card.                                                                |
| EID-3155         | An error occurred while building the menu.                                                                                          | CTC encountered an error building the menu.                                                             |
| EID-3156         | An error occurred while building the menu. Cards were not found for the {0} group.                                                  | CTC encountered an error while building the menu, as cards could not be found for the specified group). |
| EID-3157         | The selected model could not be set because of an unexpected model class: {0}.                                                      | CTC encountered an unexpected model class while trying to complete the task.                            |

**Table 4-1** Error Messages (continued)

| <b>Error/Warning ID</b> | <b>Error/Warning Message</b>                                                                                                                                             | <b>Description</b>                                                                                                                                         |
|-------------------------|--------------------------------------------------------------------------------------------------------------------------------------------------------------------------|------------------------------------------------------------------------------------------------------------------------------------------------------------|
| EID-3158                | Probable causes:<br>- Unable to switch, because a similar or higher priority condition exists on a peer or far-end card.<br>- A loopback is present on the working port. | Refer to the error message text.                                                                                                                           |
| EID-3159 <sup>1</sup>   | An error occurred while applying the operation.                                                                                                                          | CTC encountered an error while applying this operation.                                                                                                    |
| EID-3160                | An error occurred while provisioning the {0}.                                                                                                                            | CTC encountered the specified error.                                                                                                                       |
| EID-3161                | An error occurred while upgrading the ring.                                                                                                                              | An error was encountered while attempting to upgrade the BLSR. Refer to the details portion of the error dialog box for more information.                  |
| EID-3162                | This protection operation cannot be set because the protection operation on the other side has been changed but not yet applied.                                         | Refer to the error message text.                                                                                                                           |
| EID-3163                | The data in row {0} cannot be validated.                                                                                                                                 | CTC cannot validate the data for the specified row.                                                                                                        |
| EID-3164                | The new node ID ({0}) for ring ID {1} duplicates the ID of node {2}.                                                                                                     | The new specified node ID for the specified ring ID is the same as another node ID.                                                                        |
| EID-3165                | The ring ID provided is already in use. Ring IDs must be unique.                                                                                                         | Refer to the error message text.                                                                                                                           |
| EID-3166                | An error occurred while refreshing the {0} table.                                                                                                                        | CTC encountered an error while refreshing the specified table.                                                                                             |
| EID-3167                | The slot is already in use.                                                                                                                                              | Refer to the error message text.                                                                                                                           |
| EID-3168                | An error occurred while provisioning.                                                                                                                                    | An error was encountered while attempting the specified provisioning operation. Refer to the details portion of the error dialog box for more information. |
| EID-3169                | An error occurred while adding the card.                                                                                                                                 | CTC encountered an error while adding the card.                                                                                                            |
| EID-3170                | You cannot delete this card: {0}.                                                                                                                                        | Refer to the error message text.                                                                                                                           |
| EID-3171                | An error occurred while creating the trap destination.                                                                                                                   | CTC encountered an error creating the trap destination.                                                                                                    |
| EID-3172                | No RMON thresholds were selected.                                                                                                                                        | Select an RMON threshold.                                                                                                                                  |
| EID-3173                | The contact "{0}" cannot exceed {1} characters.                                                                                                                          | The specified contact exceeds the specified character limit.                                                                                               |
| EID-3174                | The description "{0}" cannot exceed {1} characters.                                                                                                                      | The specified location exceeds the specified character limit.                                                                                              |
| EID-3175                | The operator identifier "{0}" cannot exceed {1} characters.                                                                                                              | The specified operator identifier exceeds the specified character limit.                                                                                   |
| EID-3176                | The operator specific information "{0}" cannot exceed {1} characters.                                                                                                    | The specified operator specific information exceeds the specified character limit.                                                                         |

Table 4-1 Error Messages (continued)

| Error/Warning ID | Error/Warning Message                                                                   | Description                                                                                                  |
|------------------|-----------------------------------------------------------------------------------------|--------------------------------------------------------------------------------------------------------------|
| EID-3177         | The node name cannot be empty.                                                          | The specified name is empty.                                                                                 |
| EID-3178         | The node name "{0}" cannot exceed {1} characters.                                       | The specified name exceeds the specified character limit.                                                    |
| EID-3179         | The protect card is in use.                                                             | Refer to the error message text.                                                                             |
| EID-3180         | The 1+1 protection group does not exist.                                                | Create a 1+1 protection group.                                                                               |
| EID-3181         | The Y-cable protection group does not exist.                                            | Refer to the error message text.                                                                             |
| EID-3182         | The topology element is in use and cannot be deleted as requested.                      | You cannot delete the topology element which is in use.                                                      |
| EID-3183         | An error occurred while deleting the protection group.                                  | CTC encountered an error while deleting the protection group.                                                |
| EID-3184         | No {0} was selected.                                                                    | You must select an item before completing this task.                                                         |
| EID-3185         | This ring has an active protection switch operation and cannot be deleted at this time. | Refer to the error message text.                                                                             |
| EID-3186         | The node is busy: {0} is {1} and cannot be deleted as requested.                        | The request cannot be completed.                                                                             |
| EID-3187         | An error occurred while deleting the trap destination.                                  | CTC encountered an error deleting the trap destination.                                                      |
| EID-3188         | An error occurred during authentication. The password entered is invalid.               | The password you entered is invalid. Enter the password again.                                               |
| EID-3189         | The sum of the {0} must be between {1} and {2}.                                         | Refer to the error message text.                                                                             |
| EID-3214         | The number of high order circuits for the line could not be retrieved.                  | The number of High Orders (STS/STM) for the line is not available.                                           |
| EID-3215         | An error occurred while refreshing.                                                     | Used frequently in pane classes to indicate a general error condition when trying to refresh from the model. |
| EID-3216         | The proxy port is invalid.                                                              | Refer to the error message text.                                                                             |
| EID-3217         | The statistics could not be refreshed.                                                  | CTC could not refresh statistics values.                                                                     |
| EID-3218         | The automatic node setup could not be launched.                                         | Refer to the error message text.                                                                             |
| EID-3219         | The automatic node setup information could not be refreshed.                            | Failure trying to retrieve automatic node setup information.                                                 |
| EID-3220         | An error occurred while refreshing row {0}.                                             | Error refreshing the specified row.                                                                          |
| EID-3222         | The statistics could not be cleared.                                                    | Refer to the error message text.                                                                             |
| EID-3225         | An error occurred while refreshing the pane.                                            | Used frequently in pane classes to indicate a general error condition when trying to refresh from the model. |
| EID-3226         | The {0} termination(s) could not be deleted.<br>{1}                                     | Refer to the error message text.                                                                             |
| EID-3227         | A baseline could not be recorded. Performance metrics will remain unchanged.            | CTC failed to set the baseline values while provisioning NE. Previous values remain unchanged.               |

**Table 4-1** Error Messages (continued)

| <b>Error/Warning ID</b> | <b>Error/Warning Message</b>                                                                                                                                                                                               | <b>Description</b>                                                                                                                         |
|-------------------------|----------------------------------------------------------------------------------------------------------------------------------------------------------------------------------------------------------------------------|--------------------------------------------------------------------------------------------------------------------------------------------|
| EID-3228                | The {0} termination(s) could not be created.<br>{1}                                                                                                                                                                        | Refer to the error message text.                                                                                                           |
| EID-3229                | RIP is active on the LAN. Please disable RIP before enabling OSPF.                                                                                                                                                         | Turn off the Routing Information Protocol (RIP) on the LAN, before enabling OSPF.                                                          |
| EID-3230                | OSPF is active on the LAN. Please disable OSPF before enabling RIP.                                                                                                                                                        | Turn off the OSPF on the LAN before enabling RIP.                                                                                          |
| EID-3231                | An error occurred while setting the OPR.                                                                                                                                                                                   | An error was encountered while attempting to provision the optical power received (OPR).                                                   |
| WID-3232                | The port state cannot be indirectly transitioned because the port is still providing services.<br>If the port state should be changed, edit it directly through port provisioning.                                         | Edit the port state while provisioning the port.                                                                                           |
| EID-3233                | The current loopback provisioning does not allow this state transition.                                                                                                                                                    | Refer to the error message text.                                                                                                           |
| EID-3234                | The current synchronization provisioning does not allow this state transition.                                                                                                                                             | You cannot transition the port state to the target date while in the current synchronization state.                                        |
| EID-3235                | The requested state transition cannot be performed on this software version.                                                                                                                                               | Refer to the error message text.                                                                                                           |
| EID-3236                | The database restore failed. {0}                                                                                                                                                                                           | CTC failed to restore the specified database.                                                                                              |
| EID-3237                | The database backup failed. {0}                                                                                                                                                                                            | CTC failed to backup the specified database.                                                                                               |
| EID-3238                | The send PDIP setting on {0} is inconsistent with the setting on the control node {1}.                                                                                                                                     | The send payload defect indicator path (PDI-P) setting on the specified item should be consistent with that of the specified control node. |
| EID-3239                | The overhead termination is invalid                                                                                                                                                                                        | Refer to the error message text.                                                                                                           |
| EID-3240                | The maximum number of overhead terminations has been exceeded.                                                                                                                                                             | Overhead terminations have exceeded the limit.                                                                                             |
| EID-3241                | The {0} termination port is in use.                                                                                                                                                                                        | The specified termination port is in use. Select another port.                                                                             |
| EID-3242                | An {1} exists on the selected ports.<br>Therefore, you must create the {0}s one by one.                                                                                                                                    | The specified DCC already exists on the selected port. You can create a DCC of another type.                                               |
| WID-3243                | The port you have chosen as an {0} endpoint already supports an {1}. The port cannot support both DCCs. After the {0} is created, verify that no EOC alarms are present and then delete the {1} to complete the downgrade. | The same port can not be used by multiple DCCs.                                                                                            |

Table 4-1 Error Messages (continued)

| Error/Warning ID | Error/Warning Message                                                                                                                                                                                                                       | Description                                                                                                                                                                                       |
|------------------|---------------------------------------------------------------------------------------------------------------------------------------------------------------------------------------------------------------------------------------------|---------------------------------------------------------------------------------------------------------------------------------------------------------------------------------------------------|
| EID-3244         | An {0} exists on the selected ports.<br>Therefore, you must create the {1}s one by one.                                                                                                                                                     | The specified DCC already exists on the selected port. You can create a DCC of another type.                                                                                                      |
| WID-3245         | The port you have chosen as an {1} endpoint already supports an {0}. The port cannot support both DCCs. After the {1} is created, verify that no EOC alarms are present and then delete the {0} to complete the upgrade.                    | The port selected as a DCC endpoint already supports another DCC. Refer to the warning message text.                                                                                              |
| EID-3246         | The wizard was not able to validate the data.<br>{0}                                                                                                                                                                                        | CTC encountered an error.                                                                                                                                                                         |
| EID-3247         | An ordering error occurred. The absolute value should be {0}.                                                                                                                                                                               | The absolute value entered was wrong.                                                                                                                                                             |
| EID-3248         | The value for the parameter {0} is invalid.                                                                                                                                                                                                 | CTC changed the incorrect parameter.                                                                                                                                                              |
| EID-3249         | The voltage increment value is invalid.                                                                                                                                                                                                     | Refer to the error message text.                                                                                                                                                                  |
| EID-3250         | The power monitor range is invalid.                                                                                                                                                                                                         | Refer to the error message text.                                                                                                                                                                  |
| EID-3251         | The requested action could not be completed.<br>{0}                                                                                                                                                                                         | CTC could not complete the specified action.                                                                                                                                                      |
| EID-3252         | No download has been initiated from this CTC session.                                                                                                                                                                                       | Refer to the error message text.                                                                                                                                                                  |
| EID-3253         | The reboot operation failed. {0}                                                                                                                                                                                                            | Refer to the error message text.                                                                                                                                                                  |
| EID-3254         | An error occurred during validation. {0}                                                                                                                                                                                                    | The Cisco Transport Controller (CTC) was unable to validate the values entered by the user, specified by {0}. This error message is common to several different provisioning tabs within the CTC. |
| EID-3255         | You cannot change the timing configuration because a Manual/Force operation is in effect.                                                                                                                                                   | Refer to the error message text.                                                                                                                                                                  |
| WID-3256         | The timing reference(s) could not be assigned because one or more of the timing reference(s):<br>- is already used and/or<br>- has been selected twice and/or<br>- is attempting to use the same slot twice.<br>Please verify the settings. | Refer to the warning message text.                                                                                                                                                                |
| EID-3257         | Duplicate DCC numbers are not permitted. {0}.                                                                                                                                                                                               | CTC detected more than one occurrence of the a DCC number. Remove one of them.                                                                                                                    |
| EID-3258         | A software error occurred while attempting to download the file.<br>Please try again later.                                                                                                                                                 | Refer to the error message text.                                                                                                                                                                  |
| EID-3259         | An error occurred while creating the FC-MR threshold.                                                                                                                                                                                       | You must create a Fibre Channel Multirate (FC_MR) card threshold.                                                                                                                                 |
| EID-3260         | An error occurred while provisioning the internal subnet:<br>{0}                                                                                                                                                                            | The specified internal subnet could not be provisioned.                                                                                                                                           |
| EID-3261         | The port rate provisioning cannot be changed while circuits exist on this port.                                                                                                                                                             | Refer to the error message text.                                                                                                                                                                  |



Table 4-1 Error Messages (continued)

| Error/Warning ID | Error/Warning Message                                                                                                                                                                                                                            | Description                                                                                                                                                                                                                     |
|------------------|--------------------------------------------------------------------------------------------------------------------------------------------------------------------------------------------------------------------------------------------------|---------------------------------------------------------------------------------------------------------------------------------------------------------------------------------------------------------------------------------|
| EID-3262         | The port provisioning cannot be changed when the port status is {0}.                                                                                                                                                                             | You must provision the ports only when the port is Out of Service.                                                                                                                                                              |
| WID-3263         | You are using Java version {0}. CTC should run with Java version {1}. It can be obtained from the installation CD or <a href="http://java.sun.com/j2se/">http://java.sun.com/j2se/</a>                                                           | CTC is being launched with the wrong version of the JRE {0}. This version of CTC requires a particular version of the JRE {1}. The CTC and browser must be closed and restarted to allow the correct Java version to be loaded. |
| EID-3265         | An error occurred while modifying the protection group.                                                                                                                                                                                          | Protection Group could not be modified.                                                                                                                                                                                         |
| EID-3266         | Conditions could not be retrieved from the shelf or card view.                                                                                                                                                                                   | Refer to the error message text.                                                                                                                                                                                                |
| WID-3267         | The XTC protection group cannot be modified.                                                                                                                                                                                                     | Refer to the warning message text.                                                                                                                                                                                              |
| WID-3268         | The filter entry is invalid. {0}                                                                                                                                                                                                                 | The specified entry is invalid.                                                                                                                                                                                                 |
| WID-3269         | The {0} operation was successfully initiated for {1} but its completion status could not be obtained from the node. When the node is accessible, check its software version to verify if the {0} succeeded.                                      | Refer to the error message text.                                                                                                                                                                                                |
| WID-3270         | The file {0} does not exist.                                                                                                                                                                                                                     | The specified file does not exist.                                                                                                                                                                                              |
| WID-3271         | The value entered must be greater than {0}.                                                                                                                                                                                                      | The value entered must be greater than the specified value.                                                                                                                                                                     |
| WID-3272         | An entry is required.                                                                                                                                                                                                                            | An entry is required to complete this task.                                                                                                                                                                                     |
| WID-3273         | {0} already exists in the list.                                                                                                                                                                                                                  | The specified item already exists in the list.                                                                                                                                                                                  |
| WID-3274         | A software upgrade is in progress.<br>Network configuration changes that result in a node reboot cannot take place during a software upgrade.<br>Please try again after the software upgrade is done.                                            | Refer to the warning message text.                                                                                                                                                                                              |
| WID-3275         | Ensure that the remote interface ID and the local interface ID on the two sides match.<br>(The local interface ID on this node should equal the remote interface ID on the neighbor node and vice-versa).                                        | Refer to the warning message text.                                                                                                                                                                                              |
| WID-3276         | Both {0} and {1} exist on the same selected port.<br>{2}                                                                                                                                                                                         | The specified port has both SDCC and LDCC.                                                                                                                                                                                      |
| WID-3277         | The description cannot exceed {0} characters. Your input will be truncated.                                                                                                                                                                      | The input exceeds the character limit. The value will be truncated to the maximum character limit.                                                                                                                              |
| WID-3279         | This card has been deleted. CTC will return to the shelf view.                                                                                                                                                                                   | CTC returns to node view.                                                                                                                                                                                                       |
| WID-3280         | ALS will not engage until both the protected trunk ports detect LOS.                                                                                                                                                                             | Refer to the warning message text.                                                                                                                                                                                              |
| WID-3282         | Performing a software upgrade while TSC 5 is active could result in a service disruption. It is recommended that you make TSC 10 the active TSC by performing a soft reset of TSC 5. The following ONS 15600s are currently unsafe to upgrade... | Refer to the warning message text.                                                                                                                                                                                              |

Table 4-1 Error Messages (continued)

| Error/Warning ID | Error/Warning Message                                                                                                                                                                                                                                                                                      | Description                                                                                                                                                                                                 |
|------------------|------------------------------------------------------------------------------------------------------------------------------------------------------------------------------------------------------------------------------------------------------------------------------------------------------------|-------------------------------------------------------------------------------------------------------------------------------------------------------------------------------------------------------------|
| WID-3283         | Before activating a new version, ensure that you have a database backup from the current version.                                                                                                                                                                                                          | Refer to the warning message text.                                                                                                                                                                          |
| WID-3284         | Reverting to an older version.                                                                                                                                                                                                                                                                             | CTC is being reverted to an older version of application.                                                                                                                                                   |
| WID-3285         | Applying FORCE or LOCKOUT operations might result in traffic loss.                                                                                                                                                                                                                                         | Refer to the warning message text.                                                                                                                                                                          |
| WID-3286         | The ring status is INCOMPLETE. CTC cannot determine if there are existing protection operations or switches in other parts of the ring. Applying a protection operation at this time could cause a traffic outage. Please confirm that no other protection operations or switches exist before continuing. | Refer to the warning message text.                                                                                                                                                                          |
| WID-3287         | There is a protection operation or protection switch present on the ring. Applying this protection operation now will probably cause a traffic outage.                                                                                                                                                     | Refer to the warning message text.                                                                                                                                                                          |
| WID-3288         | The status of this ring is INCOMPLETE. CTC will not be able to apply this change to all of the nodes in the {0}.                                                                                                                                                                                           | Change the ring status to apply the change to all nodes in the ring type.                                                                                                                                   |
| EID-3290         | The specified provisionable patchcord(s) could not be deleted.                                                                                                                                                                                                                                             | Refer to the error message text.                                                                                                                                                                            |
| EID-3291         | The revertive behavior cannot be changed because a protection switch is active.                                                                                                                                                                                                                            | Protection switch should not be active to change the revertive behavior.                                                                                                                                    |
| EID-3292         | An error occurred while resetting the shelf.                                                                                                                                                                                                                                                               | CTC encountered an error while resetting the node.                                                                                                                                                          |
| EID-3293         | No such provisionable patchcords exists.                                                                                                                                                                                                                                                                   | You are attempting to delete a provisionable patchcord that does not exist. This happens when multiple instances of CTC are running and attempting to delete the same provisionable patchcord concurrently. |
| EID-3294         | No RMON thresholds are available for the selected port.                                                                                                                                                                                                                                                    | Refer to the error message text.                                                                                                                                                                            |
| EID-3295         | This card does not support RMON thresholds.                                                                                                                                                                                                                                                                | Refer to the error message text.                                                                                                                                                                            |
| EID-3296         | Buffer-to-buffer credit is only supported for Fibre Channel (FC) and FICON.                                                                                                                                                                                                                                | Refer to the error message text.                                                                                                                                                                            |
| EID-3298         | This interfaces does not support ALS auto restart.                                                                                                                                                                                                                                                         | Refer to the error message text.                                                                                                                                                                            |
| EID-3300         | Duplicate OSPF area IDs are not permitted.                                                                                                                                                                                                                                                                 | OSPF area IDs should be unique.                                                                                                                                                                             |
| EID-3301         | The LAN metric cannot be zero.                                                                                                                                                                                                                                                                             | Refer to the error message text.                                                                                                                                                                            |
| EID-3302         | The standby {0} is not ready.                                                                                                                                                                                                                                                                              | Standby controller card is not ready.                                                                                                                                                                       |
| EID-3303         | The DCC area ID and {0} conflict. {1}                                                                                                                                                                                                                                                                      | DCC Area ID and ring type, specified by {0}, conflict each other due to the details specified by {1}.                                                                                                       |
| EID-3304         | The DCC number is out of range.                                                                                                                                                                                                                                                                            | Enter a DCC number that is within the range                                                                                                                                                                 |
| EID-3305         | OSPF cannot be active on the LAN interface when the backbone area is set on a DCC interface.                                                                                                                                                                                                               | You cannot have the default OSPF area on a DCC while OSPF is enabled on the LAN.                                                                                                                            |
| EID-3306         | Ethernet circuits must be bidirectional.                                                                                                                                                                                                                                                                   | Refer to the error message text.                                                                                                                                                                            |

Table 4-1 Error Messages (continued)

| Error/Warning ID | Error/Warning Message                                                                         | Description                                                                                                                                       |
|------------------|-----------------------------------------------------------------------------------------------|---------------------------------------------------------------------------------------------------------------------------------------------------|
| EID-3307         | An error occurred while creating a connection object at {0}.                                  | CTC encountered an error at the specified connection while creating the connection.                                                               |
| EID-3308         | DWDM links can be used only for optical channel circuits.                                     | Refer to the error message text.                                                                                                                  |
| EID-3309         | The link was excluded because it was in the wrong direction.                                  | The optical channel (circuit) does not allow the specified link to be included because it is in the wrong optical direction.                      |
| EID-3310         | The DWDM link does not have wavelengths available.                                            | Refer to the error message text.                                                                                                                  |
| EID-3311         | The laser is already on.                                                                      | Refer to the error message text.                                                                                                                  |
| EID-3312         | The power setpoint cannot be changed.<br>{0} {1}                                              | CTC cannot change the power setpoint. The new setpoint would either make the thresholds inconsistent or set the fail threshold outside the range. |
| EID-3313         | The offset cannot be modified because the service state of the port is IS.                    | Refer to the error message text.                                                                                                                  |
| EID-3314         | The requested action is not allowed.<br>The state value is invalid.                           | Refer to the error message text.                                                                                                                  |
| EID-3315         | This operation cannot be performed.                                                           | CTC is unable to perform operation.                                                                                                               |
| EID-3316         | The node side is invalid.                                                                     | This task was applied to the wrong node side.                                                                                                     |
| EID-3317         | The ring name is too long.                                                                    | Reduce the number of characters in the name.                                                                                                      |
| EID-3318         | The ring name is invalid.                                                                     | The name you entered is illegal.                                                                                                                  |
| EID-3319         | The wrong line was selected.                                                                  | Select another line                                                                                                                               |
| EID-3320         | The optical link could not be deleted.                                                        | CTC cannot delete the optical link.                                                                                                               |
| EID-3321         | This feature is unsupported by this version of software.                                      | Refer to the error message text.                                                                                                                  |
| EID-3322         | The equipment is not plugged in.                                                              | Plug-in the equipment and proceed.                                                                                                                |
| EID-3323         | The APC system is busy.                                                                       | Automatic Power Control (APC) system is busy.                                                                                                     |
| EID-3324         | There is no path to regulate.                                                                 | There is no circuit path to regulate.                                                                                                             |
| EID-3325         | The requested action is not allowed.                                                          | Generic DWDM provisioning failure message.                                                                                                        |
| EID-3326         | The input was invalid.                                                                        | The input value is incorrect.                                                                                                                     |
| EID-3327         | An error occurred while retrieving thresholds.                                                | There was an error retrieving the thresholds. This message is displayed only for the OSCM/OSC-CSM line thresholds.                                |
| EID-3328         | An error occurred while applying changes to row {0}.<br>The value is out of range.            | There was an error applying the changes to the specified row. The value is out of range.                                                          |
| EID-3330         | Unable to switch to the byte because an overhead channel is present on this byte of the port. | Refer to the error message text.                                                                                                                  |
| EID-3331         | An error occurred while applying changes to the row.                                          | Refer to the error message text.                                                                                                                  |

Table 4-1 Error Messages (continued)

| Error/Warning ID | Error/Warning Message                                                                                                                                                         | Description                                                           |
|------------------|-------------------------------------------------------------------------------------------------------------------------------------------------------------------------------|-----------------------------------------------------------------------|
| EID-3334         | Timing parameters on the protect port cannot be changed.                                                                                                                      | You cannot change timing parameters on protect port.                  |
| EID-3335         | The port type cannot be changed because the SDH validation check failed. Check if this port is part of a circuit, protection group, SONET DCC, orderwire, or UNI-C interface. | Refer to the error message text.                                      |
| EID-3336         | An error occurred while reading a control mode value.                                                                                                                         | The Control Mode must be retrieved.                                   |
| EID-3337         | An error occurred while setting a set point gain value.                                                                                                                       | The Gain Set Point must be set.                                       |
| EID-3338         | An error occurred while reading a set-point gain value.                                                                                                                       | The Gain Set Point must be retrieved.                                 |
| EID-3339         | An error occurred while setting a tilt calibration value.                                                                                                                     | The tilt calibration must be set.                                     |
| EID-3340         | An error occurred while setting expected wavelength.                                                                                                                          | The expected wavelength must be set.                                  |
| EID-3341         | An error occurred while reading expected wavelength.                                                                                                                          | The expected wavelength must be retrieved.                            |
| EID-3342         | An error occurred while reading actual wavelength.                                                                                                                            | The actual wavelength must be retrieved.                              |
| EID-3343         | An error occurred while reading actual band.                                                                                                                                  | The actual band must be retrieved.                                    |
| EID-3344         | An error occurred while reading expected band.                                                                                                                                | The expected band must be retrieved.                                  |
| EID-3345         | An error occurred while setting expected band.                                                                                                                                | The expected band must be set.                                        |
| EID-3346         | An error occurred while retrieving defaults from the node: {0}.                                                                                                               | There was an error retrieving defaults from the specified node.       |
| EID-3347         | The file {0} cannot be loaded.                                                                                                                                                | CTC cannot load the specified file.                                   |
| EID-3348         | Properties cannot be loaded from the node.                                                                                                                                    | Refer to the error message text.                                      |
| EID-3349         | NE update properties cannot be saved to a file.                                                                                                                               | Check your file system for space constraint or any other problem.     |
| EID-3350         | NE update properties cannot be loaded from the node.                                                                                                                          | Refer to the error message text.                                      |
| EID-3351         | The file {0} does not exist.                                                                                                                                                  | The specified file does not exist.                                    |
| EID-3352         | An error occurred while setting a value at {0}.                                                                                                                               | There was an error while setting the value at the specified location. |
| EID-3353         | No such interface is available.                                                                                                                                               | The interface specified is not present in CTC.                        |
| EID-3354         | The specified endpoint is in use.                                                                                                                                             | Select another endpoint that is not in use.                           |
| EID-3355         | The specified endpoint is incompatible.                                                                                                                                       | Refer to the error message text.                                      |
| EID-3357         | The connections could not be calculated.                                                                                                                                      | Refer to the error message text.                                      |
| EID-3358         | An optical link model does not exist for the specified interface.                                                                                                             | Create an optical linkmodel for the interface, and proceed.           |
| EID-3359         | Optical parameters could not be set for the node.                                                                                                                             | Refer to the error message text.                                      |
| EID-3360         | ANS cannot be performed.<br>Please check {0} parameter value.                                                                                                                 | Refer to the error message text.                                      |
| EID-3361         | The ring termination is in use.<br>An error occurred while deleting the ring termination.                                                                                     | You cannot delete a ring in use.                                      |

Table 4-1 Error Messages (continued)

| Error/Warning ID | Error/Warning Message                                                                                                              | Description                                                                                                                                             |
|------------------|------------------------------------------------------------------------------------------------------------------------------------|---------------------------------------------------------------------------------------------------------------------------------------------------------|
| EID-3362         | An error occurred while deleting the ring termination.                                                                             | There was an error while deleting ring termination.                                                                                                     |
| EID-3363         | No ring terminations were selected.                                                                                                | You must select a ring termination.                                                                                                                     |
| EID-3364         | An error occurred while creating the ring ID.                                                                                      | There was an error while creating the ring ID.                                                                                                          |
| EID-3365         | The OSC termination is in use.                                                                                                     | Select another optical service channel (OSC) which is not in use.                                                                                       |
| EID-3366         | The OSC termination could not be deleted.                                                                                          | There was an error deleting the OSC termination.                                                                                                        |
| EID-3370         | No optical link was selected.                                                                                                      | You must select an optical link.                                                                                                                        |
| EID-3371         | An error occurred while calculating the automatic optical link list.                                                               | Refer to the error message text.                                                                                                                        |
| EID-3372         | CTC attempted to access an OCHNC connection that has been destroyed.                                                               | CTC destroyed an external attempt to access an optical channel network connection.                                                                      |
| EID-3375         | The expected span loss must be set.                                                                                                | Refer to the error message text.                                                                                                                        |
| EID-3376         | The measured span loss could not be retrieved.                                                                                     | Refer to the error message text.                                                                                                                        |
| EID-3377         | The wrong interface was used.                                                                                                      | The interface used for the card is wrong.                                                                                                               |
| EID-3378         | This is a duplicate origination patchcord identifier.                                                                              | The provisionable patchcord identifier to the patchcord you are attempting to provision is already in use by another patchcord on the origination node. |
| EID-3379         | This is a duplicate termination patchcord identifier.                                                                              | The provisionable patchcord identifier to the patchcord you are attempting to provision is already in use by another patchcord on the remote node.      |
| EID-3380         | The host cannot be found.                                                                                                          | Refer to the error message text.                                                                                                                        |
| EID-3381         | The maximum frame size must be between {0} and {1} and may be increased in increments of {2}.                                      | The frame size must be in the specified range. This can increment by the specified value.                                                               |
| EID-3382         | The number of credits must be between {0} and {1}.                                                                                 | The number of credits must be between the specified values.                                                                                             |
| EID-3383         | The GFP buffers available must be between {0} and {1} and may be increased in increments of {2}.                                   | The GFP buffers must be in the specified range. This can increment by the specified value.                                                              |
| WID-3384         | You are about to force the use of Secure Mode for this chassis. You will not be able to undo this operation. Is it OK to continue? | Refer to the warning message text.                                                                                                                      |
| EID-3385         | {0}. Delete the circuits and try again.                                                                                            | Refer to the error message text.                                                                                                                        |
| EID-3386         | The transponder mode could not be provisioned: {0}                                                                                 | The specified transponder mode cannot be provisioned.                                                                                                   |

Table 4-1 Error Messages (continued)

| Error/Warning ID | Error/Warning Message                                                                                                                                                                                                          | Description                                                                                                                |
|------------------|--------------------------------------------------------------------------------------------------------------------------------------------------------------------------------------------------------------------------------|----------------------------------------------------------------------------------------------------------------------------|
| EID-3387         | You must change port(s) {0} to an out-of-service state before changing card parameters. Click "Reset" to revert the changes.                                                                                                   | All the card ports should be changed to out-of-service before changing the parameters.                                     |
| EID-3388         | The card mode cannot be changed because the card has circuits.                                                                                                                                                                 | Refer to the error message text.                                                                                           |
| EID-3389         | An error occurred while changing the card mode.                                                                                                                                                                                | Refer to the error message text.                                                                                           |
| EID-3390         | The port is in use.                                                                                                                                                                                                            | Refer to the error message text.                                                                                           |
| EID-3391         | The port rate cannot be changed because the port has been deleted.                                                                                                                                                             | You cannot change the port rate of a card that has been deleted.                                                           |
| WID-3392         | The timing reference(s) could not be assigned because with external timing, only a single protected, or two unprotected timing references per BITS Out can be selected. Please use the "Reset" button and verify the settings. | Refer to the warning message text.                                                                                         |
| WID-3393         | The timing reference(s) could not be assigned because with line or mixed timing, only a single unprotected timing reference per BITS Out can be selected. Please use the "Reset" button and verify the settings.               | Refer to the warning message text.                                                                                         |
| EID-3394         | An error occurred while refreshing the power monitoring values.                                                                                                                                                                | Refer to the error message text.                                                                                           |
| EID-3395         | The configuration is invalid. {0}                                                                                                                                                                                              | CTC encountered an error in IP address, net mask length, or default router, or a restricted IIOP port was selected.        |
| EID-3396         | The configuration is invalid. The standby controller card is not a TCC2P card.                                                                                                                                                 | The standby controller card should be a TCC2P card.                                                                        |
| EID-3397         | The file {0} is the wrong version.                                                                                                                                                                                             | The specified file is of wrong version.                                                                                    |
| EID-3398         | The PPM cannot be deleted.                                                                                                                                                                                                     | Refer to the error message text.                                                                                           |
| EID-3399         | The PPM cannot be deleted because it has port(s) in use.                                                                                                                                                                       | Remove the ports connected to the Pluggable Port Module before it can be deleted.                                          |
| EID-3400         | Unable to switch. A force to the primary facility is not allowed.                                                                                                                                                              | Refer to the error message text.                                                                                           |
| EID-3401         | {0} cannot be provisioned for the port while {1} is enabled.                                                                                                                                                                   | The relationship between parameters {0} and {1} are such that enabling either one, prevents the provisioning of the other. |
| EID-3402         | The switch request could not be completed. The {0} card is not present or is not responding. Try again after ensuring that the {0} card is present and is not resetting.                                                       | Refer to the error message text.                                                                                           |
| EID-3403         | The administrative state transition has not been attempted on the monitored port.                                                                                                                                              | Refer to the error message text.                                                                                           |

Table 4-1 Error Messages (continued)

| Error/Warning ID | Error/Warning Message                                                                                                                                                                                                                                                                                                                                                                | Description                                                                                                              |
|------------------|--------------------------------------------------------------------------------------------------------------------------------------------------------------------------------------------------------------------------------------------------------------------------------------------------------------------------------------------------------------------------------------|--------------------------------------------------------------------------------------------------------------------------|
| EID-3404         | The far end IP address could not be set on the {0} termination.<br>The IP address cannot be:<br>loopback (127.0.0.0/8)<br>class D (224.0.0.0/4)<br>class E (240.0.0.0/4)<br>broadcast (255.255.255.255/32)<br>internal {1}                                                                                                                                                           | Refer to the error message text.                                                                                         |
| EID-3405         | You cannot change card parameters with port {0} in {1} state.<br>Click "Reset" to revert the changes.                                                                                                                                                                                                                                                                                | Refer to the error message text.                                                                                         |
| EID-4000         | The {0} ring name cannot be changed now because a {0} switch is active.                                                                                                                                                                                                                                                                                                              | You cannot change the ring name because a switch of the same ring type is active.                                        |
| EID-4001         | The {0} node ID cannot be changed now because a {0} switch is active.                                                                                                                                                                                                                                                                                                                | You cannot change the ring ID because a switch of the same ring type is active.                                          |
| WID-4002         | CAUTION: Reverting to an earlier software release may result in TRAFFIC LOSS and loss of connectivity to the node. It may require onsite provisioning to recover.<br>If the node was running {0} before, reverting will restore the {0} provisioning, losing any later provisioning. If the node was running some other version, reverting will LOSE ALL PROVISIONING.<br>{1}<br>{2} | Refer to the warning message text.                                                                                       |
| EID-4003         | The Cisco IOS console is disabled for the card in Slot {0}.                                                                                                                                                                                                                                                                                                                          | The card may not be an IOS-based card or it may be rebooting.                                                            |
| EID-4004         | An error occurred while canceling the software upgrade.                                                                                                                                                                                                                                                                                                                              | CTC encountered an error while cancelling the software upgrade.                                                          |
| EID-4005         | {0} encountered while performing a database backup.                                                                                                                                                                                                                                                                                                                                  | CTC encountered the specified error during database backup.                                                              |
| EID-4006         | The file {0} does not exist or cannot be read.                                                                                                                                                                                                                                                                                                                                       | Refer to error message.                                                                                                  |
| EID-4007         | The size of the file {0} is zero.                                                                                                                                                                                                                                                                                                                                                    | The size of the file that is being backed up or restored is zero.                                                        |
| WID-4008         | A software upgrade is in progress.<br>{0} cannot proceed during a software upgrade.<br>Please try again after the software upgrade has completed.                                                                                                                                                                                                                                    | The specified action cannot be performed during a software upgrade. You must try after the upgrade process is completed. |
| EID-4009         | {0} encountered while restoring the database.                                                                                                                                                                                                                                                                                                                                        | CTC encountered the specified error while restoring the database.                                                        |
| EID-4010         | The operation was terminated because:<br>{0}                                                                                                                                                                                                                                                                                                                                         | Refer to the error message text.                                                                                         |
| EID-4011         | An error occurred during provisioning:<br>{0}                                                                                                                                                                                                                                                                                                                                        | Refer to the error message text.                                                                                         |
| WID-4012         | Node management for {0} is not provided.                                                                                                                                                                                                                                                                                                                                             | Refer to the warning message text.                                                                                       |

Table 4-1 Error Messages (continued)

| Error/Warning ID | Error/Warning Message                                                                                                                                                                                                                                                                                                                                                                       | Description                                                                                                                                      |
|------------------|---------------------------------------------------------------------------------------------------------------------------------------------------------------------------------------------------------------------------------------------------------------------------------------------------------------------------------------------------------------------------------------------|--------------------------------------------------------------------------------------------------------------------------------------------------|
| EID-4013         | CAUTION: Reverting to an earlier software release may result in TRAFFIC LOSS and loss of connectivity to the node. It may require onsite provisioning to recover.<br>If the node was running {0} before, reverting will restore the {0} provisioning, losing any later provisioning. If the node was running some other version, reverting will LOSE ALL PROVISIONING.<br>{1}<br>{2}<br>{3} | Refer to the error message text.                                                                                                                 |
| EID-4014         | The manual path trace mode for this equipment does not support an expected string consisting of all null characters. Please change the expected string or the path trace mode.                                                                                                                                                                                                              | The path trace mode does not support strings that consist of null characters. You must either change the expected string or the path trace mode. |
| EID-4015         | Software activation is in progress. Provisioning is not allowed.                                                                                                                                                                                                                                                                                                                            | Refer to the error message text.                                                                                                                 |
| EID-4016         | Software activation is in progress. {0} is not allowed.                                                                                                                                                                                                                                                                                                                                     | Refer to the error message text.                                                                                                                 |
| EID-4017         | Path Trace mode cannot be set at this endpoint.<br>The circuit is one-way.                                                                                                                                                                                                                                                                                                                  | Refer to the error message text.                                                                                                                 |
| WID-4018         | {0} already exists.<br>Do you want to replace it?                                                                                                                                                                                                                                                                                                                                           | Refer to the warning message text.                                                                                                               |
| EID-4019         | Profile cannot be mapped because the UNI Port is not in transparent mode.                                                                                                                                                                                                                                                                                                                   | Refer to the error message text.                                                                                                                 |
| EID-4020         | Profile cannot be mapped because the transparent mode UNI Port tagged VLAN is not {0}.                                                                                                                                                                                                                                                                                                      | Refer to the error message text.                                                                                                                 |
| EID-4021         | Profile cannot be mapped because SVLAN {0} is not enabled for the NNI Port.                                                                                                                                                                                                                                                                                                                 | Refer to the error message text.                                                                                                                 |
| EID-4022         | The user already exists.                                                                                                                                                                                                                                                                                                                                                                    | Refer to the error message text.                                                                                                                 |
| EID-4023         | Access control already exists for the group selected.                                                                                                                                                                                                                                                                                                                                       | Refer to the error message text.                                                                                                                 |
| EID-4024         | The View already exists.                                                                                                                                                                                                                                                                                                                                                                    | Refer to the error message text.                                                                                                                 |
| EID-4025         | Invalid Mask entry, cant be more then {0} the length of OID.                                                                                                                                                                                                                                                                                                                                | Refer to the error message text.                                                                                                                 |
| EID-4026         | CTC was unable to create a new view.                                                                                                                                                                                                                                                                                                                                                        | Refer to the error message text.                                                                                                                 |
| EID-4027         | Name and Subtree OID cant be empty.                                                                                                                                                                                                                                                                                                                                                         | Refer to the error message text.                                                                                                                 |
| EID-4028         | Password will be sent as plain text.                                                                                                                                                                                                                                                                                                                                                        | Refer to the error message text.                                                                                                                 |
| EID-4029         | The passowrds must be at least {0} characters long.                                                                                                                                                                                                                                                                                                                                         | Refer to the error message text.                                                                                                                 |
| EID-4030         | The admitted SVLAN values must be in the range [1-4093].                                                                                                                                                                                                                                                                                                                                    | Refer to the error message text.                                                                                                                 |
| EID-4031         | On {0} interface the Recover from Fiber Cut Fails.                                                                                                                                                                                                                                                                                                                                          | Refer to the error message text.                                                                                                                 |
| EID-5000         | A valid route cannot be found for the tunnel change request.                                                                                                                                                                                                                                                                                                                                | Refer to the error message text.                                                                                                                 |
| EID-5001         | The tunnel could not be changed.                                                                                                                                                                                                                                                                                                                                                            | Refer to the error message text.                                                                                                                 |
| EID-5002         | The tunnel could not be restored and must be recreated manually.                                                                                                                                                                                                                                                                                                                            | Refer to the error message text.                                                                                                                 |



Table 4-1 Error Messages (continued)

| Error/Warning ID | Error/Warning Message                                                                                                                                                             | Description                                                                                                                                            |
|------------------|-----------------------------------------------------------------------------------------------------------------------------------------------------------------------------------|--------------------------------------------------------------------------------------------------------------------------------------------------------|
| EID-5003         | The circuit roll failed.<br>{0}                                                                                                                                                   | Refer to the error message text.                                                                                                                       |
| EID-5004         | There is already one four-fiber {0} provisioned on the set of nodes involved in {1}. The maximum number of four-fiber {0} rings has been reached for that node.                   | There is already one 4F BLSR provisioned on the set of nodes involved in the ring. The maximum number of 4F BLSR rings has been reached for that node. |
| WID-5005         | A non-zero hold-off time can violate switching time standards, and should only be used for a circuit with multiple path selectors.                                                | Refer to the warning message text.                                                                                                                     |
| WID-5006         | Warning: A different secondary {0} node should only be used for DRI or open-ended path protected circuits.                                                                        | You should use different secondary end point only for DRI or open-ended path protected circuits.                                                       |
| WID-5007         | If you change the scope of this view, the contents of this profile editor will be lost.                                                                                           | Refer to the warning message text.                                                                                                                     |
| WID-5008         | Please ensure that all the protection groups are in proper states after the cancellation.                                                                                         | Refer to the warning message text.                                                                                                                     |
| WID-5009         | The circuit {0} is not upgradable.<br>No {1} capable {2}s are available at the node {3}.                                                                                          | No VT capable STSs are available at the node.                                                                                                          |
| EID-5010         | The domain name already exists.                                                                                                                                                   | Refer to the error message text.                                                                                                                       |
| EID-5011         | The domain name cannot exceed {0} characters.                                                                                                                                     | You may have reached the maximum number of characters.                                                                                                 |
| WID-5012         | The software load on {0} does not support the addition of a node to a 1+1 protection group.                                                                                       | Refer to the warning message text.                                                                                                                     |
| EID-5013         | {0} does not support the bridge and roll feature. Please select a different port.                                                                                                 | The specified port does not support Bridge and Roll.                                                                                                   |
| EID-5014         | An automatic network layout is already in progress.<br>Please wait for it to complete before running it again.                                                                    | You must for the automatic network layout to complete before running it again.                                                                         |
| WID-5015         | {0} cannot be applied to {1}.                                                                                                                                                     | You cannot apply the admin state operation, specified by {0}, to port count, specified by {1}.                                                         |
| EID-5016         | An error occurred while attempting to provision the {0}.<br>{1}                                                                                                                   | CTC encountered an error while provisioning the card.                                                                                                  |
| EID-5017         | Provisioning could not be rolled back. The {0} might be left in an INCOMPLETE state and should be manually removed.                                                               | You may have to remove the BLSR manually as it was left incomplete.                                                                                    |
| EID-5018         | {0} is a(n) {1} node and cannot be added to a(n) {2} network.                                                                                                                     | You cannot add the node {0} of type {1} to the host node of type {2}. This prevents you from hosting both SONET and SDH nodes in the same session.     |
| EID-5019         | The manual path trace mode for this equipment does not support an expected string consisting of all null characters.<br>Please change the expected string or the path trace mode. | The path trace mode does not support strings that consist of null characters. You must either change the expected string or the path trace mode.       |

Table 4-1 Error Messages (continued)

| Error/Warning ID | Error/Warning Message                                                                                                                                                                                                                      | Description                                                                                                                          |
|------------------|--------------------------------------------------------------------------------------------------------------------------------------------------------------------------------------------------------------------------------------------|--------------------------------------------------------------------------------------------------------------------------------------|
| EID-5020         | Software activation is in progress. Provisioning is not allowed.                                                                                                                                                                           | Refer to the warning message text.                                                                                                   |
| EID-5021         | Software activation is in progress. {0} is not allowed.                                                                                                                                                                                    | Refer to the error message text.                                                                                                     |
| WID-5022         | Warning: Ethergroup circuits are stateless (that is, always in service).<br>The current state selection of {0} will be ignored.                                                                                                            | Refer to the warning message text.                                                                                                   |
| EID-5023         | CTC cannot communicate with the node.<br>The operation failed.                                                                                                                                                                             | CTC encountered a network communication error. Connectivity between CTC and the NE was disrupted, either transiently or permanently. |
| EID-5024         | The overhead circuit will not be upgraded.                                                                                                                                                                                                 | Refer to the error message text.                                                                                                     |
| WID-5025         | The path targeted for this switch request is already active. The switch request can be applied, but traffic will not switch at this time.                                                                                                  | Refer to the warning message text.                                                                                                   |
| EID-5026         | An ONS 15600 cannot serve as the primary or secondary node in a four-fiber {0} circuit. Please change your ring and/or node selections so that an ONS 15600 is not chosen as the primary or secondary node in this four-fiber {1} circuit. | Refer to the error message text.                                                                                                     |
| WID-5027         | The {0} Edit dialog box for the ring {1} has been closed due to significant provisioning changes. These changes might only be transitory, so you can reopen the {0} Edit dialog box to view the updated state.                             | Re-open the BLSR/MS-SPRing edit window to view the updated state of the ring.                                                        |
| WID-5028         | Warning: This operation should only be used to clean up rolls that are stuck. It might also affect completeness of the circuit. Is it OK to continue with the deletion?                                                                    | Refer to the warning message text.                                                                                                   |
| EID-5029         | A software downgrade cannot be performed to the selected version while an SSXC card is inserted in this shelf. Please follow the steps to replace the SSXC with a CXC card before continuing the software downgrade.                       | Refer to the error message text.                                                                                                     |
| EID-5030         | A software downgrade cannot be performed at the present time.                                                                                                                                                                              | Try the software downgrade later.                                                                                                    |
| WID-5031         | Canceling a software upgrade during a standby TSC clock acquisition might result in a traffic outage.                                                                                                                                      | Refer to the warning message text.                                                                                                   |
| EID-5032         | An error occurred while accepting the load.                                                                                                                                                                                                | Refer to the error message text.                                                                                                     |
| EID-5033         | The profile could not be loaded.<br>An error occurred while decoding the characters.                                                                                                                                                       | CTC detected an error while decoding characters and could not load the profile.                                                      |
| EID-5034         | The profile could not be loaded.<br>An error occurred while trying to recognize the file format.                                                                                                                                           | CTC detected an error and could not load the profile.                                                                                |
| EID-5035         | The profile could not be loaded.<br>An error occurred while reading the file.                                                                                                                                                              | CTC could not read the file and is therefore unable to load the profile.                                                             |
| EID-5036         | The GNE hostname {0} is invalid.                                                                                                                                                                                                           | The specified host name is invalid. CTC could not resolve the host name to any valid IP address                                      |

Table 4-1 Error Messages (continued)

| Error/Warning ID | Error/Warning Message                                                                                                                                                                                         | Description                                                                                                                                                 |
|------------------|---------------------------------------------------------------------------------------------------------------------------------------------------------------------------------------------------------------|-------------------------------------------------------------------------------------------------------------------------------------------------------------|
| EID-5037         | Provisionable patchcords cannot be created between transponder trunk ports and multiplexer/demultiplexer ports on the same node.                                                                              | You must create provisionable patchcords between transponder trunk ports and mux/demux ports that are on different nodes.                                   |
| EID-5038         | Provisionable patchcords created between transponder trunk ports and multiplexer/demultiplexer ports must use the same wavelength:<br>{0} is not equal to {1}.                                                | Wavelengths used by provisionable patchcords for transponder trunk ports and mux/demux ports must be the same.                                              |
| EID-5039         | Provisionable patchcords created between transponder trunk ports and multiplexer/demultiplexer ports must use the same wavelength:<br>{0} is not equal to {1}.<br>Please provision the {2} wavelength on {3}. | Transmitter and receiver port wavelengths are not equal. Provision the receiver and transmitter wavelengths on transmitter and receiver ports respectively. |
| EID-5040         | Provisionable patchcords created between OC3/OC12 ports and multiplexer/demultiplexer ports are not supported.                                                                                                | Refer to the error message text.                                                                                                                            |
| EID-5041         | Provisionable patchcords created between gray OC-N trunk ports and multiplexer/demultiplexer ports are not supported.                                                                                         | Refer to the error message text.                                                                                                                            |
| EID-5042         | Provisionable patchcords created between OC-N trunk ports and multiplexer/demultiplexer ports must use the same wavelength:<br>{0} is not equal to {1}.                                                       | Wavelengths used by provisionable patchcords for OC-N trunk ports and mux/demux ports must be the same.                                                     |
| WID-5043         | Warning: Only the line card was provisioned.<br>The wavelength compatibility check was skipped.                                                                                                               | Refer to the warning message text.                                                                                                                          |
| EID-5044         | Virtual links can be used only for OCH-Trail circuits.                                                                                                                                                        | Refer to the error message text.                                                                                                                            |
| EID-5045         | The virtual link does not have wavelengths available.                                                                                                                                                         | Set wavelengths for the virtual link and proceed.                                                                                                           |
| WID-5046         | Warning: if you select "Use OCHNC Direction," your circuit will be limited to nodes prior to release 07.00.                                                                                                   | Refer to the warning message text.                                                                                                                          |
| EID-5047         | Provisionable patchcords created between OC3/OC12 ports are not supported.                                                                                                                                    | Refer to the error message text.                                                                                                                            |
| EID-5048         | Provisionable patchcords created between gray OC-N trunk ports are not supported.                                                                                                                             | Refer to the error message text.                                                                                                                            |
| EID-5049         | Provisionable patchcords created between gray OC-N trunk ports and multiplexer/demultiplexer ports are not supported.                                                                                         | Refer to the error message text.                                                                                                                            |
| EID-5050         | The element model could not be found.<br>{0}                                                                                                                                                                  | The specified Element Model cannot be located.                                                                                                              |
| WID-5051         | The port state cannot be indirectly transitioned because the port aggregates OCHCC circuits: if the port state needs to be changed, edit it directly through port provisioning.                               | Refer to the warning message text.                                                                                                                          |
| EID-5052         | The operation is not valid for the connection type.                                                                                                                                                           | You may have selected the incorrect switch.                                                                                                                 |
| EID-5053         | The operation cannot be performed because the connection is under test access.                                                                                                                                | Refer to the error message text.                                                                                                                            |

Table 4-1 Error Messages (continued)

| Error/Warning ID | Error/Warning Message                                                                                                                                                                                                                                                                           | Description                                                                                  |
|------------------|-------------------------------------------------------------------------------------------------------------------------------------------------------------------------------------------------------------------------------------------------------------------------------------------------|----------------------------------------------------------------------------------------------|
| EID-5054         | The TL1 tunnel could not be opened. {0}                                                                                                                                                                                                                                                         | Refer to the error message text.                                                             |
| EID-5055         | Some patchcords were not deleted. Patchcords cannot be deleted if they are incomplete or support any circuits, or if the nodes supporting them are not connected.                                                                                                                               | Refer to the error message text.                                                             |
| EID-5056         | This PPC cannot be deleted because one or more circuits are provisioned over it.                                                                                                                                                                                                                | Remove the circuits provisioned over the provisionable patchcord before trying to delete it. |
| EID-5057         | The addition of the last node has not yet finished. Please wait before trying to add a new node.                                                                                                                                                                                                | Refer to the error message text.                                                             |
| EID-5058         | An OCHNC upgrade is applicable only to bidirectional circuits.                                                                                                                                                                                                                                  | Refer to the error message text.                                                             |
| EID-5059         | The OCHNC upgrade failed. One or more communication failures occurred during the operation.                                                                                                                                                                                                     | CTC encountered a complete failure while upgrading optical channel network connection.       |
| EID-5060         | The OCHNC upgrade partially failed. One or more communication failures occurred during the operation. Create the OCHCC manually.                                                                                                                                                                | CTC encountered a partial failure while upgrading an optical channel network connection.     |
| EID-5061         | The overhead circuit source and destination must reside on the same shelf.                                                                                                                                                                                                                      | Refer to the error message text.                                                             |
| EID-5062         | A four-fiber {0} cannot be created using three cards.                                                                                                                                                                                                                                           | A four-fiber BLSR needs four cards.                                                          |
| WID-5063         | The profile "{0}" includes a change to the OPEN-SLOT alarm severity. This change is disallowed for the ONS 15600. "{1}" will continue to use the OPEN-SLOT severity of MN that is included in the default configuration. Other changes from the "{2}" profile were successfully applied to {3}. | Refer to the warning message text.                                                           |
| EID-5064         | {0}<br>{1}                                                                                                                                                                                                                                                                                      | This indicates the status of path protection switching.                                      |
| WID-5065         | If you apply routing constraints to more than {0} nodes, performance might be affected and the operation might require more time than expected. Select Yes if you intend to proceed in spite of this risk, or No if you prefer to review your selection.                                        | Refer to the warning message text.                                                           |
| WID-5066         | The routing constraints will be lost. Are you sure you want to reset your changes?                                                                                                                                                                                                              | Refer to the warning message text.                                                           |
| WID-5067         | The routing constraints will be lost. Are you sure you want to leave this panel?                                                                                                                                                                                                                | Refer to the warning message text.                                                           |
| EID-5068         | The routing constraints could not be applied.                                                                                                                                                                                                                                                   | Refer to the error message text.                                                             |
| EID-5069         | A source node cannot be added to either of these lists.                                                                                                                                                                                                                                         | Select a node other than the source node to add to the route.                                |

**Table 4-1** Error Messages (continued)

| <b>Error/Warning ID</b> | <b>Error/Warning Message</b>                                                                                                                                                                                                                                                | <b>Description</b>                                                                                           |
|-------------------------|-----------------------------------------------------------------------------------------------------------------------------------------------------------------------------------------------------------------------------------------------------------------------------|--------------------------------------------------------------------------------------------------------------|
| EID-5070                | A destination node cannot be added to either of these lists.                                                                                                                                                                                                                | Select a node other than the destination node to add to the route.                                           |
| EID-5071                | This node already belongs to one of these lists.                                                                                                                                                                                                                            | The node is already selected either in include or exclude list in the OCH circuit.                           |
| EID-5072                | An OCH-Trail tunnel link was found but without any associated circuit.                                                                                                                                                                                                      | Create an OCH-Trail circuit associated with the link.                                                        |
| EID-5073                | You are creating an unprotected link from a protected port.<br>Do you want to continue?                                                                                                                                                                                     | Refer to the error message.                                                                                  |
| EID-5074                | Deleting OCH DCN circuits will cause a loss of connectivity to nodes in the circuit path that do not have other DCN connections.<br>Do you want to continue?                                                                                                                | Refer to the error message.                                                                                  |
| EID-5075                | The VLAN ID must be a number between 1 and 4093.                                                                                                                                                                                                                            | Enter a number between 1 and 4093.                                                                           |
| EID-5076                | An error occurred while provisioning the VLAN ID.<br>The VLAN ID is already present in the current profile                                                                                                                                                                  | Select a VLAN ID that is not present in the current profile.                                                 |
| EID-5077                | An error occurred while provisioning the VLAN database profile.<br>{0}                                                                                                                                                                                                      | CTC could not save the VLAN profile to the file name mentioned.                                              |
| EID-5078                | The VLAN merge is not complete.<br>You forgot to fill {0} record(s).                                                                                                                                                                                                        | Fill in the number of records specified and then proceed.                                                    |
| EID-5079                | An error occurred while validating the provisionable patchcord.                                                                                                                                                                                                             | Refer to the error message text.                                                                             |
| EID-5080                | No rolls are available.                                                                                                                                                                                                                                                     | You cannot delete a roll without selecting a roll.                                                           |
| EID-5081                | An error occurred while tracing the RPR ring:<br>{0}                                                                                                                                                                                                                        | The circuit reference is invalid.                                                                            |
| EID-5082                | {0} does not support:<br>- Low-order circuits that have both {1}-protected and {2}-protected spans and that cross a node that does not have low-order cross-connect capability.<br>- High-order circuits that carry low-order circuits with the parameters described above. | Refer to the error message text.                                                                             |
| EID-5083                | This circuit is not the same size as the existing circuit {0}.<br>This circuit has size {1} and the existing circuit has size {2}.                                                                                                                                          | During an RPR circuit creation ML card, the new circuit size and the existing circuit size must be the same. |
| EID-5084                | The Trunk model could not be found.<br>{0}                                                                                                                                                                                                                                  | The trunk specified is not found.                                                                            |
| EID-5085                | The maximum number of VLAN DB profiles is {0}.                                                                                                                                                                                                                              | Refer to the error message.                                                                                  |
| EID-5086                | The circuit roll failed.<br>You cannot bridge and roll the selected circuit because it has a monitor circuit.                                                                                                                                                               | Refer to the error message.                                                                                  |
| EID-5087                | You cannot use same slot for east working and west protect ports.                                                                                                                                                                                                           | Refer to the error message text.                                                                             |

Table 4-1 Error Messages (continued)

| Error/Warning ID | Error/Warning Message                                                                                                                 | Description                                               |
|------------------|---------------------------------------------------------------------------------------------------------------------------------------|-----------------------------------------------------------|
| EID-5088         | You cannot use same slot for east working and west protect ports.                                                                     | Refer to the error message text.                          |
| WID-5089         | The maximum number of circuits that can be deleted at a time is 200.<br>Do you want to delete the first 200 circuits selected?        | Refer to the error message text                           |
| EID-5090         | This operation cannot be completed.<br>The selected circuits have different state models;<br>please select circuits of the same type. | Refer to the error message text                           |
| EID-5091         | Some PPC terminations were not repaired.                                                                                              | Refer to the error message text                           |
| WID-5092         | The TL1 encoding mode for the tunnel is being changed.<br>Do you want to modify the encoding?                                         | Confirm if you really want to modify TL1 tunnel encoding. |
| EID-5094         | Currently, CTC does not support bridge and roll on circuits having multiple cross-connects on a single node.                          | Refer to the error message text.                          |
| EID-5095         | No path were selected.<br>Please select at least one path starting from the {0} NE.                                                   | Refer to the error message text.                          |
| EID-5096         | The first path must starts from the {0} NE.                                                                                           | Refer to the error message text.                          |
| EID-5097         | The selected path should be linked with the last selected and keep the same direction.                                                | Refer to the error message text.                          |
| EID-5098         | The node is not selectable.<br>Only the Span between the nodes are selectable.                                                        | Refer to the error message text.                          |
| EID-5099         | Raman Command Error on {0}.<br>{1}.                                                                                                   | Refer to the error message text.                          |
| EID-5100         | Raman Command in TimeOut.<br>{0}.                                                                                                     | Refer to the error message text.                          |
| EID-5101         | Failed to get trunk ports for client.<br>{0}.                                                                                         | Refer to the error message text.                          |
| EID-5102         | Protected cards must have 2 trunk ports.<br>(found {0}).                                                                              | Refer to the error message text.                          |
| EID-5103         | Failed to get colocated OCH ports for trunk:<br>{0}.                                                                                  | Refer to the error message text.                          |
| EID-5104         | Both OCHCC and OCHNC Protected are not allowed.                                                                                       | Refer to the error message text.                          |
| EID-5105         | Cannot find entity model for endpoint:<br>{0}.                                                                                        | Refer to the error message text.                          |
| EID-5106         | Cannot find Out OTS line for selected endpoint:<br>{0}.                                                                               | Refer to the error message text.                          |
| EID-5107         | Cannot find Protected Out OTS line for selected endpoint:<br>{0}.                                                                     | Refer to the error message text.                          |
| EID-5108         | The demultiplexer associated with the selected endpoint<br>:{0} is missing or not connected.                                          | Refer to the error message text.                          |

**Table 4-1** Error Messages (continued)

| <b>Error/Warning ID</b> | <b>Error/Warning Message</b>                                                                                                                                                                                                                         | <b>Description</b>                 |
|-------------------------|------------------------------------------------------------------------------------------------------------------------------------------------------------------------------------------------------------------------------------------------------|------------------------------------|
| EID-5109                | The demultiplexer associated with the protect path for the selected endpoint:<br>{0} is missing or not connected.                                                                                                                                    | Refer to the error message text.   |
| EID-5110                | The card selection is invalid.<br>No cards were selected.                                                                                                                                                                                            | Refer to the error message text.   |
| EID-5111                | An error was occurred while configuring SNMPv3 proxy server.                                                                                                                                                                                         | Refer to the error message text.   |
| EID-5112                | No source of trap was selected.                                                                                                                                                                                                                      | Refer to the error message text.   |
| EID-5113                | Specify a valid value for target tag.                                                                                                                                                                                                                | Refer to the error message text.   |
| EID-5114                | Specify a valid value for context engine ID.                                                                                                                                                                                                         | Refer to the error message text.   |
| EID-5115                | No value was selected for proxy type.                                                                                                                                                                                                                | Refer to the error message text.   |
| EID-5116                | No value was selected for local user.                                                                                                                                                                                                                | Refer to the error message text.   |
| EID-5117                | No value was selected for proxy destination.                                                                                                                                                                                                         | Refer to the error message text.   |
| EID-5118                | Specify a valid value for target IP.                                                                                                                                                                                                                 | Refer to the error message text.   |
| EID-5119                | The password for authentication should be at least 8 characters long.                                                                                                                                                                                | Refer to the error message text.   |
| EID-5120                | The user name should be atleast 6 characters long.                                                                                                                                                                                                   | Refer to the error message text.   |
| EID-5122                | The node ( {0} ) does not support ML-MR POS port protection.                                                                                                                                                                                         | Refer to the error message text.   |
| EID-5123                | Primary ( {0} ) and secondary ( {1} ) nodes have to be the same for ML-MR POS port protection.                                                                                                                                                       | Refer to the error message text.   |
| EID-5124                | No nodes appear to support a Pseudo IOS connection.                                                                                                                                                                                                  | Refer to the error message text.   |
| EID-5125                | No node was selected.                                                                                                                                                                                                                                | Refer to the error message text.   |
| EID-5126                | The Pseudo IOS console is disabled for the selected node.                                                                                                                                                                                            | Refer to the error message text.   |
| EID-5127                | The password for encryption should be at least 8 characters long.                                                                                                                                                                                    | Refer to the error message text.   |
| EID-5128                | {0} configuration already exists for the {1} {2} with the specified parameters.                                                                                                                                                                      | Refer to the error message text.   |
| WID-5129                | Failed to retrieve the complete OSPF database as it is very large.<br>Please contact Cisco Technical Support ( <a href="http://www.cisco.com/techsupport">http://www.cisco.com/techsupport</a> ) if you want to retrieve the complete OSPF database. | Refer to the warning message text. |
| EID-5130                | Connection failed on node {0}                                                                                                                                                                                                                        | Refer to the error message text.   |
| EID-5131                | An error occurred while deleting the circuit end point.                                                                                                                                                                                              | Refer to the error message text.   |
| WID-5132                | Failed to retrieve the status of Proxy server on the node.<br>Please contact Cisco Technical Support ( <a href="http://www.cisco.com/techsupport">http://www.cisco.com/techsupport</a> ) if you want to retrieve the Proxy status.                   | Refer to the warning message text. |
| EID-5133                | SNMPv3 Proxy configuration already exists for the specified parameters.                                                                                                                                                                              | Refer to the error message text.   |

Table 4-1 Error Messages (continued)

| Error/Warning ID | Error/Warning Message                                                                                                                                                                                                                                            | Description                                                                                           |
|------------------|------------------------------------------------------------------------------------------------------------------------------------------------------------------------------------------------------------------------------------------------------------------|-------------------------------------------------------------------------------------------------------|
| EID-5134         | On node {0} the calculated gain is much greater than expected. The wizard cannot operate under this condition. Please call TAC for support.                                                                                                                      | Refer to the error message text.                                                                      |
| EID-6000         | This platform does not support power monitoring thresholds.                                                                                                                                                                                                      | Refer to the error message text.                                                                      |
| EID-6001         | One of the XC cards has failures or is missing.                                                                                                                                                                                                                  | Check whether all the cross-connect cards are installed and working.                                  |
| EID-6002         | One of the XC cards is locked.                                                                                                                                                                                                                                   | Unlock the cross-connect card.                                                                        |
| EID-6003         | The OSC termination could not be created. This ring ID is already assigned.                                                                                                                                                                                      | Enter a new ID for the ring.                                                                          |
| EID-6004         | A system reset cannot be performed while a BLSR ring is provisioned on the node.                                                                                                                                                                                 | Remove the BLSR from the node and continue with the reset procedure.                                  |
| EID-6005         | The timing references could not be assigned.<br>- Only two DS1 or BITS interfaces can be specified.<br>- DS1 interfaces cannot be retimed and used as a reference.<br>- BITS-2 is not supported on this platform.                                                | Refer to the error message text.                                                                      |
| EID-6006         | The timing references could not be assigned.<br>- An NE reference can only be used if the timing mode is LINE.<br>- A BITS reference can only be used if the timing mode is not LINE.<br>- A Line reference can only be used if the timing mode is not EXTERNAL. | Refer to the error message text.                                                                      |
| EID-6008         | SF BER and SD BER are not provisionable on the protect line of a protection group.                                                                                                                                                                               | Refer to the error message text.                                                                      |
| WID-6009         | If autoadjust GFP buffers is disabled, GFP buffers available must be set to an appropriate value based on the distance between the circuit endpoints.                                                                                                            | Refer to the warning message text.                                                                    |
| WID-6010         | If auto detection of credits is disabled, credits available must be set to a value less than or equal to the number of receive credits on the connected FC endpoint.                                                                                             | Refer to the warning message text.                                                                    |
| WID-6011         | Ingress idle filtering should be turned off only when required to operate with non-Cisco Fibre Channel/FICON-over-SONET equipment.                                                                                                                               | Refer to the warning message text.                                                                    |
| EID-6012         | The retiming configuration could not be changed because there are circuits on this port.                                                                                                                                                                         | You cannot change the timing configuration on this port unless the circuits on this port are deleted. |
| EID-6013         | The NTP/SNTP server could not be changed.<br>{1}                                                                                                                                                                                                                 | Refer to the error message text.                                                                      |
| EID-6014         | The operation failed because the reference state is OOS.                                                                                                                                                                                                         | Change the Out-of-service state to Active.                                                            |
| EID-6015         | The distance extension cannot be disabled if the port media type is FICON 1Gbps ISL or FICON 2Gbps ISL.                                                                                                                                                          | Refer to the error message text.                                                                      |



Table 4-1 Error Messages (continued)

| Error/Warning ID | Error/Warning Message                                                                                                    | Description                                                                                                     |
|------------------|--------------------------------------------------------------------------------------------------------------------------|-----------------------------------------------------------------------------------------------------------------|
| EID-6016         | The card mode cannot be changed to Fibre Channel Line Rate if the port media type is FICON 1Gbps ISL or FICON 2Gbps ISL. | Refer to the error message text.                                                                                |
| EID-6017         | The destination of a {0} route cannot be a node IP address.                                                              | A node IP address cannot be the destination for a static route.                                                 |
| EID-6018         | The destination of a {0} route cannot be the same as the subnet used by the node.                                        | Refer to the error message text.                                                                                |
| EID-6019         | The destination of a static route cannot be 255.255.255.255                                                              | The network address such as 255.255.255.255 is not valid. Enter a valid address.                                |
| EID-6020         | The destination of a static route cannot be the loopback network (127.0.0.0/8).                                          | Refer to the error message text.                                                                                |
| EID-6021         | The subnet mask length for a non default route must be between 8 and 32.                                                 | Length of subnet mask must be within the specified range.                                                       |
| EID-6022         | The subnet mask length for a default route must be 0.                                                                    | Refer to the error message text.                                                                                |
| EID-6023         | The destination of a {0} route cannot be an internal network{1}.                                                         | The destination of a static route must not be an internal network.                                              |
| EID-6024         | The destination of a {0} route cannot be a class D (224.0.0.0/4) or class E (240.0.0.0/4) address.                       | The destination of a static route must not be a class D or class E address.                                     |
| EID-6025         | The destination of a {0} route cannot be a class A broadcast address (x.255.255.255/8).                                  | The destination of a static route must not be a class A broadcast address. It should be (xxx.0.0.0).            |
| EID-6026         | The destination of a {0} route cannot be a class B broadcast address (x.x.255.255/16).                                   | The destination of a static route must not be a class B broadcast address.                                      |
| EID-6027         | The destination of a {0} route cannot be a class C broadcast address (x.x.x.255/24).                                     | The destination of a static route must not be a class C broadcast address.                                      |
| EID-6028         | The destination of a {0} route cannot be the subnet broadcast address associated with a node IP address.                 | The destination of a static route must not be a subnet broadcast address of a node IP.                          |
| EID-6029         | The next hop of a static route cannot be the same as the destination of the route or an internal network{0}.             | Static route must have the default route as the next hop, and not destination of the route or internal network. |
| EID-6030         | The next hop of a static default route must be the provisioned default router.                                           | The default route is selected for networks that do not have a specific route.                                   |
| EID-6031         | No more static routes can be created.                                                                                    | You have reached the maximum number of static routes.                                                           |
| EID-6032         | This static route already exists.                                                                                        | Refer to the error message text.                                                                                |
| EID-6033         | A previous operation is still in progress.                                                                               | Another operation is in progress. You must try after sometime.                                                  |
| EID-6035         | The parent entity does not exist.                                                                                        | Refer to the error message text.                                                                                |
| EID-6036         | The parent PPM entity does not exist.                                                                                    | Create a parent entity for the PPM.                                                                             |
| EID-6037         | This equipment type is not supported.                                                                                    | CTC does not support this equipment.                                                                            |

Table 4-1 Error Messages (continued)

| Error/Warning ID | Error/Warning Message                                                       | Description                                                                     |
|------------------|-----------------------------------------------------------------------------|---------------------------------------------------------------------------------|
| EID-6038         | The PPM port is invalid.                                                    | Refer to the error message text.                                                |
| EID-6039         | The card is part of a regeneration group.                                   | Select another card.                                                            |
| EID-6040         | Out of memory.                                                              | Refer to the error message text.                                                |
| EID-6041         | The port is already present.                                                | Refer to the error message text.                                                |
| EID-6042         | The port is used as timing source.                                          | Choose another port because the selected port is being used as a timing source. |
| EID-6043         | A DCC or GCC is present.                                                    | Refer to the error message text.                                                |
| EID-6044         | The card or port is part of protection group.                               | Refer to the error message text.                                                |
| EID-6045         | The port has overhead circuit(s).                                           | Refer to the error message text.                                                |
| EID-6046         | The ITU-T G.709 configuration is not compatible with the data rate.         | Refer to the error message text.                                                |
| EID-6047         | The port cannot be deleted because its service state is OOS-MA,LPBK&MT.     | To delete the port, you must change the port state to OOS-DSBLD.                |
| EID-6048         | {0} is {1}.                                                                 | The trunk port is in the wrong state to carry out the action.                   |
| EID-6049         | The card operating mode of {0} is not supported.                            | CTC does not support the mode of operation requested on the card.               |
| EID-6050         | Some {0} terminations were not {1}d.<br>{2}                                 | Refer to the error message text.                                                |
| WID-6051         | All {0} terminations were {1}d successfully.<br>{2}                         | Refer to the warning message text.                                              |
| EID-6052         | The authentication key can not be blank.                                    | Enter an authentication key.                                                    |
| EID-6053         | No more SNMP trap destinations can be created.                              | You have reached the maximum number of SNMP trap destinations.                  |
| EID-6054         | {0} is not a valid IP address for an SNMP trap destination.                 | The IP address specified is not a valid receiver of SNMP traps.                 |
| EID-6055         | The IP address is already in use.                                           | Refer to the error message text.                                                |
| EID-6056         | The SNMP trap destination is invalid. {0}                                   | The specified SNMP trap destination is invalid. Choose another destination.     |
| WID-6057         | Changing the card mode will result in an automatic reset.                   | Refer to the warning message text.                                              |
| EID-6058         | The maximum number of IP-over-CLNS tunnels has been exceeded.               | Refer to the error message text.                                                |
| EID-6059         | The specified IP-over-CLNS tunnel already exists!                           | Specify another IP Over CLNS tunnel.                                            |
| EID-6060         | An error occurred while trying to {0} an IP-over-CLNS tunnel entry:<br>{1}. | Refer to the error message text.                                                |
| EID-6061         | An error occurred while deleting the IP-over-CLNS tunnel entry.             | CTC encountered an error while deleting the IP Over CLNS tunnel entry.          |
| EID-6062         | The selected IP-over-CLNS tunnel does not exist.                            | Create a IP Over CLNS tunnel.                                                   |

Table 4-1 Error Messages (continued)

| Error/Warning ID | Error/Warning Message                                                                                                                        | Description                                                                                   |
|------------------|----------------------------------------------------------------------------------------------------------------------------------------------|-----------------------------------------------------------------------------------------------|
| EID-6063         | The selected router does not exist.                                                                                                          | Create a router.                                                                              |
| EID-6064         | The MAA address list is full.                                                                                                                | Refer to the error message text.                                                              |
| EID-6065         | The selected area address is duplicated.                                                                                                     | Enter another area address.                                                                   |
| EID-6066         | The primary area address cannot be removed.                                                                                                  | Refer to the error message text.                                                              |
| EID-6067         | The selected area address does not exist.                                                                                                    | Choose another area address.                                                                  |
| EID-6068         | The IP-over-CLNS NSEL cannot be modified while there are IP-over-CLNS tunnel routes provisioned.                                             | You cannot change the NSEL address if tunnels are provisioned.                                |
| EID-6069         | The node is currently in ES mode. Only Router 1 can be provisioned.                                                                          | An End System needs only one provisioned router.                                              |
| EID-6070         | No router was selected.                                                                                                                      | Select a router.                                                                              |
| EID-6071         | The TARP data cache cannot be flushed.                                                                                                       | You cannot flush the cache in the Tunnel identifier Address Resolution Protocol (TARP) state. |
| EID-6072         | The TARP data cache entry cannot be added:<br>{0}                                                                                            | You cannot add the specified cache entry.                                                     |
| WID-6073         | A TARP request has been initiated.<br>Try refreshing the TARP data cache later.                                                              | Refer to the warning message text.                                                            |
| EID-6074         | End system mode only supports one subnet.                                                                                                    | Refer to the error message text.                                                              |
| EID-6075         | An error occurred while trying to remove a MAT entry. The entry does not exist.                                                              | CTC is removing the MAT entry.                                                                |
| EID-6076         | An error occurred while trying to {0} a TARP manual adjacency entry:<br>{1}                                                                  | CTC cannot add the specified adjacency entry for reasons unknown.                             |
| EID-6077         | The area address must be between 1 and 13 bytes long, inclusive.                                                                             | The area address should not be more than 13 characters.                                       |
| EID-6078         | A TDC entry with this TID {0} does not exist in the table.                                                                                   | The specified Tunnel Identifier does not exist.                                               |
| EID-6079         | A TDC entry with this TID {0} could not be removed.<br>Please verify that TARP is enabled.                                                   | You must enable TARP to remove the TDC entry.                                                 |
| WID-6080         | Router {0} does not have an area address in common with Router 1. Switching from IS L1/L2 to IS L1 in this case will partition your network. | Refer to the warning message text.                                                            |
| EID-6081         | The limit of 10 RADIUS server entries has been reached.                                                                                      | CTC does not allow more than 10 RADIUS servers.                                               |
| EID-6082         | {0} cannot be empty.                                                                                                                         | The Shared Secrets field should not be empty.                                                 |
| EID-6083         | The entry you selected for editing has been altered by another user. The changes cannot be committed.                                        | Refer to the error message text.                                                              |
| EID-6084         | The RADIUS server entry already exists.                                                                                                      | Specify another RADIUS server entry.                                                          |

Table 4-1 Error Messages (continued)

| Error/Warning ID | Error/Warning Message                                                                                                         | Description                                                              |
|------------------|-------------------------------------------------------------------------------------------------------------------------------|--------------------------------------------------------------------------|
| WID-6085         | Disabling shell access will prevent Cisco TAC from connecting to the vxWorks shell to assist users.                           | Refer to the warning message text.                                       |
| EID-6086         | The card cannot be changed because card resources are in use.                                                                 | The card you are trying to remove is being used. Cannot change the card. |
| EID-6087         | The card cannot be changed because the card type is invalid or incompatible.                                                  | Refer to the error message text.                                         |
| EID-6088         | This line cannot be put into loopback while it is in use as a timing source.                                                  | Refer to the error message text.                                         |
| EID-6089         | The interface was not found. {0}                                                                                              | CTC cannot find the specified interface.                                 |
| EID-6090         | The interface type is not valid for this operation. {0}                                                                       | Choose another interface.                                                |
| EID-6091         | The current state of the interface prohibits this operation. {0}                                                              | The port is in an invalid state to set a loopback.                       |
| EID-6092         | This operation is prohibited for this interface. {0}                                                                          | CTC does not allow this operation for the specified interface.           |
| EID-6093         | The maximum number of TARP data cache entries has been exceeded.                                                              | You have exceeded the number of characters permitted.                    |
| EID-6094         | The maximum number of manual adjacency table entries has been exceeded.                                                       | Refer to the error message text.                                         |
| EID-6095         | The AIS/Squelch mode is invalid.                                                                                              | Refer to the error message text.                                         |
| EID-6096         | A default IP-over-CLNS tunnel route is only allowed on a node without a default static route and a default router of 0.0.0.0. | Refer to the error message text.                                         |
| EID-6097         | The authorization key does not comply with Cisco IOS password restrictions.<br>{0}                                            | Specify another authorization key.                                       |
| EID-6098         | A default static route is not allowed when a default IP-over-CLNS tunnel exists.                                              | Refer to the error message text.                                         |
| EID-6099         | You cannot create a subnet on a disabled router.                                                                              | Create the subnet on an active router.                                   |
| WID-6100         | Disabling a router that has a provisioned subnet is not recommended.                                                          | Refer to the warning message text.                                       |
| EID-6101         | The MAT entry already exists.                                                                                                 | Refer to the error message text.                                         |
| WID-6102         | The new card has less bandwidth than the current card. Circuits of size VT15 and larger will be deleted.                      | Refer to the warning message text.                                       |
| EID-6103         | The TDC entry already exists.                                                                                                 | Specify another entry for TARP Data Cache.                               |
| EID-6104         | APC ABORTED.                                                                                                                  | Automatic Power Control is aborted.                                      |
| EID-6105         | The 'Change Card' command is valid for MRC cards only when Port 1 is the sole provisioned port.                               | Refer to the error message text.                                         |
| EID-6106         | To delete all RADIUS server entries, RADIUS authentication must be disabled.                                                  | Disable Radius authentication and proceed.                               |

Table 4-1 Error Messages (continued)

| Error/Warning ID | Error/Warning Message                                                                                                                                                                                                                                                                                 | Description                                                                                                                                                                                                                      |
|------------------|-------------------------------------------------------------------------------------------------------------------------------------------------------------------------------------------------------------------------------------------------------------------------------------------------------|----------------------------------------------------------------------------------------------------------------------------------------------------------------------------------------------------------------------------------|
| EID-6107         | The node failed to restart the TELNET service on the selected port. Try using another unreserved port that is not being used within the following ranges:<br>23, 1001-9999 (with the exception of 1080, 2001-2017, 2361, 3081-3083, 4001-4017, 4022, 4081, 4083, 5000, 5001, 7200, 9100, 9300, 9401). | Refer to the error message text.                                                                                                                                                                                                 |
| EID-6108         | That port is already in use.                                                                                                                                                                                                                                                                          | Restart a TELNET session.                                                                                                                                                                                                        |
| EID-6109         | A section trace is active on the trunk port. The action cannot be completed.                                                                                                                                                                                                                          | Actions such as putting the port in an incomplete state are not permitted while a section trace is active.                                                                                                                       |
| EID-6110         | The maximum number of TARP requests has been reached.                                                                                                                                                                                                                                                 | You have exceeded the maximum number of TARP requests.                                                                                                                                                                           |
| EID-6111         | The card in Slot {0} cannot be removed from the protection group while its traffic is switched.                                                                                                                                                                                                       | Refer to the error message text.                                                                                                                                                                                                 |
| EID-6112         | An error occurred while adding a shelf: {0}                                                                                                                                                                                                                                                           | The shelf ID specified is invalid or already exists, the equipment does not support multishelf, the specified shelf position is out of range, or the specified shelf position is already in use.                                 |
| EID-6113         | An error occurred while deleting a shelf: {0}                                                                                                                                                                                                                                                         | One or more of the equipment modules (provisioned virtual links, provisioned server trails, provisioned protection groups, or provisioned DCCs) in the shelf is currently in use. Delete cards from all the slots and try again. |
| EID-6114         | The maximum number of supported shelves has already been provisioned.                                                                                                                                                                                                                                 | Refer to the error message text.                                                                                                                                                                                                 |
| EID-6115         | There are bad or duplicate shelf positions.<br>Valid rack numbers are {0} to {1}.<br>Valid rack positions are {2} to {3}.                                                                                                                                                                             | Refer to the error message text.                                                                                                                                                                                                 |
| EID-6116         | CTC attempted to access an OCH-Trail connection that has been destroyed.                                                                                                                                                                                                                              | Software has prevented an attempt to access an OCH trail.                                                                                                                                                                        |
| EID-6117         | CTC attempted to access an OCH-Trail audit that has been destroyed.                                                                                                                                                                                                                                   | The resource cannot be accessed because it is released or fully utilized.                                                                                                                                                        |
| WID-6118         | The following slots are provisioned but do not have cards installed:<br>{0}<br>CTC will assume they are ITU-T interfaces.                                                                                                                                                                             | Refer to the warning message text.                                                                                                                                                                                               |
| EID-6119         | The shelves could not be rearranged.<br>{0}                                                                                                                                                                                                                                                           | One of the following conditions is present: duplicate shelf positions, invalid shelf positions, or concurrent movement (two CTC sessions are attempting to rearrange the shelves at the same time.)                              |
| EID-6120         | This equipment does not support multishelf.                                                                                                                                                                                                                                                           | Refer to the error message text.                                                                                                                                                                                                 |

Table 4-1 Error Messages (continued)

| Error/Warning ID | Error/Warning Message                                                                                                                                                                                                                                                                                                                                                                                                                                              | Description                                                                                                                                        |
|------------------|--------------------------------------------------------------------------------------------------------------------------------------------------------------------------------------------------------------------------------------------------------------------------------------------------------------------------------------------------------------------------------------------------------------------------------------------------------------------|----------------------------------------------------------------------------------------------------------------------------------------------------|
| WID-6121         | This internal patchcord cannot be provisioned because the endpoints have no compatible wavelengths.                                                                                                                                                                                                                                                                                                                                                                | The end points of an internal patchcord should have compatible wavelengths.                                                                        |
| EID-6122         | The wizard could not be started.<br>{0}                                                                                                                                                                                                                                                                                                                                                                                                                            | CTC was unable to initiate the wizard due to the specified reason.                                                                                 |
| EID-6123         | The OSI request can not be completed successfully.                                                                                                                                                                                                                                                                                                                                                                                                                 | A communication failure occurred.                                                                                                                  |
| EID-6124         | The ALS recovery pulse interval is invalid.                                                                                                                                                                                                                                                                                                                                                                                                                        | Refer to the error message text.                                                                                                                   |
| EID-6125         | The ALS recovery pulse duration is invalid.                                                                                                                                                                                                                                                                                                                                                                                                                        | Refer to the error message text.                                                                                                                   |
| EID-6126         | The current setting does not support the specified ALS mode.                                                                                                                                                                                                                                                                                                                                                                                                       | Refer to the error message text.                                                                                                                   |
| EID-6127         | All enabled routers are required to have the same area.                                                                                                                                                                                                                                                                                                                                                                                                            | Refer to the error message text.                                                                                                                   |
| EID-6128         | A software download is in progress. Configuration changes that result in a card reboot cannot take place during a software download.<br>Please try again after the software download is done.                                                                                                                                                                                                                                                                      | Refer to the error message text.                                                                                                                   |
| EID-6129         | The payload configuration and card mode are incompatible.                                                                                                                                                                                                                                                                                                                                                                                                          | Refer to the error message text.                                                                                                                   |
| EID-6135         | A DCC is present.                                                                                                                                                                                                                                                                                                                                                                                                                                                  | A data communication channel (DCC) already exists.                                                                                                 |
| EID-6136         | An error occurred during provisioning: {0}                                                                                                                                                                                                                                                                                                                                                                                                                         | CTC was not able to provision the specified port or card.                                                                                          |
| EID-6137         | Multishelf cannot be disabled.<br>{0}                                                                                                                                                                                                                                                                                                                                                                                                                              | Multishelf is not supported on equipment, is already disabled, or modules on the shelf are currently in use.                                       |
| EID-6138         | The LAN configuration is invalid.                                                                                                                                                                                                                                                                                                                                                                                                                                  | Verify the LAN configuration.                                                                                                                      |
| EID-6139         | Invalid card(s) are present.<br>Please remove all non-MSTP cards and try again.                                                                                                                                                                                                                                                                                                                                                                                    | Non-DWDM cards cannot be added to an a DWDM node. Remove the cards.                                                                                |
| EID-6140         | The shelf identifier for a subtended shelf cannot be provisioned through CTC. It must be changed using the LCD.                                                                                                                                                                                                                                                                                                                                                    | Refer to the error message text.                                                                                                                   |
| EID-6143         | The DHCP server could not be changed.                                                                                                                                                                                                                                                                                                                                                                                                                              | Refer to the error message text.                                                                                                                   |
| EID-6144         | The port provisioning cannot be changed when the port media is Undefined.                                                                                                                                                                                                                                                                                                                                                                                          | If the port is not pre-provisioned with the type of media that is going to be inserted, you cannot access any of the existing values for the port. |
| WID-6145         | OSPF on LAN should only be enabled when the LAN routers run OSPF. Otherwise, the node will not be reachable from outside its subnet.<br>RIP implementation only advertise routes in one direction to connected routers. It does not learn or distribute routes advertised by other routers.<br>Also note that enabling OSPF on the LAN will temporarily cause the current list of static routes to stop being advertised to remote nodes and only be used locally. | Refer to the warning message text.                                                                                                                 |

Table 4-1 Error Messages (continued)

| Error/Warning ID | Error/Warning Message                                                                                                                                                                                                                                                                                                                               | Description                                                                                               |
|------------------|-----------------------------------------------------------------------------------------------------------------------------------------------------------------------------------------------------------------------------------------------------------------------------------------------------------------------------------------------------|-----------------------------------------------------------------------------------------------------------|
| WID-6146         | Deleting the protection group while in a switched state might cause a loss of traffic. It is recommended that you verify switch states before proceeding.                                                                                                                                                                                           | Refer to the warning message text.                                                                        |
| EID-6149         | The LAPD MTU size must be greater than or equal to the {0} LSP buffer size {1}. Alternatively, you can decrease the {0} LSP buffer size to {2}.                                                                                                                                                                                                     | Refer to the error message text.                                                                          |
| EID-6150         | The value is out of range.                                                                                                                                                                                                                                                                                                                          | Enter a value that is within the range.                                                                   |
| EID-6151         | The minimum span loss must be less than the maximum span loss.                                                                                                                                                                                                                                                                                      | Refer to the error message text.                                                                          |
| EID-6152         | The "Use NTP/SNTP Server" field is checked. Enter the NTP/SNTP server IP address or server name.                                                                                                                                                                                                                                                    | Enter the NTP/SNTP server name. To leave this field empty, uncheck the "Use NTP/SNTP Server" and proceed. |
| EID-6153         | The maximum frame size is invalid.                                                                                                                                                                                                                                                                                                                  | Refer to the error message text.                                                                          |
| EID-6154         | To combine unidirectional two-port provisioning and autonegotiation on the same port, autonegotiation must be set first.                                                                                                                                                                                                                            | Refer to the error message text.                                                                          |
| EID-6155         | Transponder mode cannot be provisioned with circuits on the card.                                                                                                                                                                                                                                                                                   | Refer to the error message text.                                                                          |
| EID-6156         | The transponder configuration is invalid.                                                                                                                                                                                                                                                                                                           | The transponder is not configured properly.                                                               |
| EID-6157         | The watermark values are either out of range or inconsistent.                                                                                                                                                                                                                                                                                       | Enter valid watermark values.                                                                             |
| EID-6179         | The 1+1 protection group is not optimized.                                                                                                                                                                                                                                                                                                          | Refer to the error message text.                                                                          |
| EID-6196         | The equipment has failed or is missing.                                                                                                                                                                                                                                                                                                             | Operation is requested on a failed or missing equipment.                                                  |
| EID-6197         | Attributes cannot be changed when the port administrative state is {0}.                                                                                                                                                                                                                                                                             | You cannot change the attributes when the port is in the specified administrative state.                  |
| WID-6204         | This action will cause the node to reboot. When provisioning in single-shelf mode, Shelf {0} of the node that you connect to must be properly preprovisioned or you will lose traffic. Use the LCD to return to single-shelf mode. CTC cannot be used for this. Changing from subtended shelf mode to single-shelf mode could be traffic-affecting. | Refer to the warning message text.                                                                        |
| EID-6205         | The interlink port is not provisioned.                                                                                                                                                                                                                                                                                                              | The user creates an ADM peer group without interlink ports.                                               |
| EID-6206         | The ADM peer group has already been created on the peer card.                                                                                                                                                                                                                                                                                       | The user creates an ADM peer group involving an ADM card inserted in a peer group.                        |
| EID-6207         | This card is not in the ADM peer group.                                                                                                                                                                                                                                                                                                             | The selected ADM card is not involved in an ADM peer group.                                               |
| EID-6208         | The payload is not OTU2.                                                                                                                                                                                                                                                                                                                            | Refer to the error message text.                                                                          |
| EID-6209         | The side is already defined by the node.                                                                                                                                                                                                                                                                                                            | During the creation of a side on node, a side is already defined.                                         |

Table 4-1 Error Messages (continued)

| Error/Warning ID | Error/Warning Message                                                                                                                                                                                                                              | Description                                                                                                      |
|------------------|----------------------------------------------------------------------------------------------------------------------------------------------------------------------------------------------------------------------------------------------------|------------------------------------------------------------------------------------------------------------------|
| EID-6210         | No side was selected.                                                                                                                                                                                                                              | The user requests an operation on a side, but no side is selected.                                               |
| EID-6211         | The side was not deleted.                                                                                                                                                                                                                          | CTC could not delete the selected side successfully.                                                             |
| EID-6212         | One of the ports is connected to a patchcord or virtual link.                                                                                                                                                                                      | An operation on a port was not performed because the port is connected to a patchcord or a virtual link.         |
| EID-6213         | It is not possible to associate the side to the two ports.                                                                                                                                                                                         | During the creation of a side it is not possible to associate the selected ports to the new side.                |
| EID-6214         | The port is already assigned to a side.                                                                                                                                                                                                            | The selected port is already assigned to a side.                                                                 |
| EID-6215         | Error provisioning the CVLAN ID.<br>Enter a valid number or range between 0 and 4094.                                                                                                                                                              | The entered CVLAN ID was out of the admitted range.                                                              |
| EID-6216         | Changing card will reset the optical thresholds to the default setting and may affect the optical connection.<br>The optical connection will work only if the optical performance is compatible with {0} card.<br>Please check the network design. | Refer to the error message text.                                                                                 |
| EID-6217         | You cannot delete the {0} {1}.                                                                                                                                                                                                                     | You cannot delete {0} {1} because it is part of an ADM peer group or one or more circuits are provisioned on it. |
| EID-6218         | Invalid ethernet duplex value                                                                                                                                                                                                                      | the Ethernet duplex value is invalid. Enter again.                                                               |
| EID-6219         | Invalid committed info rate                                                                                                                                                                                                                        | The committed info rate value is invalid. Enter again.                                                           |
| EID-6220         | Invalid mode value                                                                                                                                                                                                                                 | The mode value is invalid. Enter again.                                                                          |
| EID-6221         | Invalid mtu value                                                                                                                                                                                                                                  | The MTU value is invalid. Enter again.                                                                           |
| EID-6222         | Invalid flow control value                                                                                                                                                                                                                         | The flow control value is invalid. Enter again.                                                                  |
| EID-6223         | Invalid Network Interface Mode                                                                                                                                                                                                                     | The network interface mode value is invalid. Enter again.                                                        |
| EID-6224         | Invalid ingress COS value                                                                                                                                                                                                                          | The ingress COS value is invalid. Enter again.                                                                   |
| EID-6225         | Invalid ethertype value                                                                                                                                                                                                                            | The Ethertype value is invalid. Enter again.                                                                     |
| EID-6226         | Invalid buffer size value                                                                                                                                                                                                                          | The Buffer size value is invalid. Enter again.                                                                   |
| EID-6227         | Invalid egress QOS value                                                                                                                                                                                                                           | The egress QOS value is invalid. Enter again.                                                                    |
| EID-6228         | Invalid QinQ working Mode                                                                                                                                                                                                                          | The QinQ working mode is invalid. Enter again.                                                                   |



Table 4-1 Error Messages (continued)

| Error/Warning ID | Error/Warning Message                                                                                                          | Description                                                          |
|------------------|--------------------------------------------------------------------------------------------------------------------------------|----------------------------------------------------------------------|
| EID-6229         | Configured protection status Not Supported                                                                                     | The protection status is not supported                               |
| EID-6230         | The number of provisioned entries exceeds the limit                                                                            | Refer to the error message text.                                     |
| EID-6231         | This is not a valid VLAN ID.                                                                                                   | Entered VLAN ID is not present in the database file.                 |
| EID-6232         | The VLAN remapping ID is not allowed.                                                                                          | Refer to the error message text.                                     |
| EID-6233         | The CVLAN is duplicated.                                                                                                       | You cannot have identical CVLAN IDs.                                 |
| EID-6234         | The VLAN ID is out of range.                                                                                                   | The VLAN ID entered is out of range.                                 |
| EID-6235         | This is not a valid VLAN name.                                                                                                 | The entered VLAN name exceeds the number of characters (32) allowed. |
| EID-6236         | The protected VLAN number exceeds the maximum allowed.                                                                         | The user enters more than 1024 protected VLAN in the VLAN database.  |
| EID-6237         | The port is not in OOS disabled admin state                                                                                    | Refer to the error message text.                                     |
| EID-6238         | The VLAN ID is in use.                                                                                                         | The entered VLAN ID is in use by a node.                             |
| EID-6239         | APC wrong node side.                                                                                                           | Refer to the error message text.                                     |
| EID-6240         | You cannot change the Admin State for an interlink port when it is part of an ADM peer group. This operation is not supported. | Refer to the error message text.                                     |
| EID-6242         | The protection slot is invalid.                                                                                                | You must select a valid protection slot.                             |
| EID-6243         | The {0} address of {1} is invalid.                                                                                             | Refer to the error message text.                                     |
| EID-6244         | The mask of {0} is invalid.                                                                                                    | The mask of the specified value is not valid.                        |
| EID-6245         | The cost must be between 1 and 32767.                                                                                          | Refer to the error message text.                                     |
| EID-6246         | The {0} address cannot be {1}.                                                                                                 | Refer to the error message text.                                     |
| EID-6247         | The authentication type is invalid.                                                                                            | Enter a valid authentication type.                                   |
| EID-6248         | The cost must between 1 and 15.                                                                                                | Refer to the error message text.                                     |
| EID-6249         | The port has a cross-connect.                                                                                                  | Refer to the error message text.                                     |
| EID-6250         | The reversion time is invalid.                                                                                                 | The reversion time is invalid. Enter again.                          |
| EID-6251         | Invalid Margin For Span Aging.<br>Value is not in the range 0 - 10.                                                            | Enter a value between 0 and 10.                                      |
| EID-6252         | The data cannot be retrieved because ANS parameters cannot be calculated on the node in its current configuration.             | Refer to the error message text.                                     |
| EID-6253         | Invalid Margin For Span Aging.                                                                                                 | Refer to the error message text.                                     |
| EID-6254         | SDH mode does not support timing references.                                                                                   | Timing reference is not supported by SDH mode.                       |
| EID-6255         | Only DS1 interfaces with ESF line types support timing references.                                                             | Refer to the error message text.                                     |
| EID-6256         | sendDoNotUse and sendDoNotUseFF are mutually exclusive.                                                                        | Refer to the error message text.                                     |
| EID-6257         | The termination is already in use.                                                                                             | Refer to the error message text.                                     |
| EID-6258         | The side is carrying services or traffic.                                                                                      | Refer to the error message text.                                     |

Table 4-1 Error Messages (continued)

| Error/Warning ID | Error/Warning Message                                                                                                                                                               | Description                                                                                                                                                                                             |
|------------------|-------------------------------------------------------------------------------------------------------------------------------------------------------------------------------------|---------------------------------------------------------------------------------------------------------------------------------------------------------------------------------------------------------|
| EID-6259         | A pluggable module on Port 22 remains unmanaged.                                                                                                                                    | Refer to the error message text.                                                                                                                                                                        |
| EID-6260         | You cannot delete this port.<br>There was a severe architectural error related to the index of the pluggable trunk port object.<br>Please contact technical support for assistance. | Refer to the error message text.                                                                                                                                                                        |
| EID-6261         | This is not a valid VLAN ID. The VLAN database is empty.                                                                                                                            | The user adds a row without a valid VLAN database loaded.                                                                                                                                               |
| EID-6263         | The equipment requires two slots.                                                                                                                                                   | The user provisions a double footprint card in a single slot.                                                                                                                                           |
| EID-6264         | The patchcord is duplicated.                                                                                                                                                        | Refer to the error message text.                                                                                                                                                                        |
| EID-6265         | The wavelength is in use by an OCH trail, a virtual link, or an internal patchcord.                                                                                                 | Refer to the error message text.                                                                                                                                                                        |
| EID-6266         | The card cannot be changed because the port has not been provisioned.                                                                                                               | Refer to the error message text.                                                                                                                                                                        |
| EID-6267         | Each port can have a maximum of 8 MAC addresses.                                                                                                                                    | Refer to the error message text.                                                                                                                                                                        |
| EID-6268         | This server trail does not have a valid start or end.                                                                                                                               | Refer to the error message text.                                                                                                                                                                        |
| EID-6269         | The maximum number of server trails is 3743.                                                                                                                                        | Refer to the error message text.                                                                                                                                                                        |
| EID-6270         | A unique server trail ID could not be allocated.                                                                                                                                    | Refer to the error message text.                                                                                                                                                                        |
| EID-6271         | The server trail already exists.                                                                                                                                                    | Refer to the error message text.                                                                                                                                                                        |
| EID-6272         | The server trail size must not exceed the port bandwidth.                                                                                                                           | Refer to the error message text.                                                                                                                                                                        |
| EID-6273         | An OCH Trail circuit is active on the trunk port.<br>To modify the ITU-T G.709 parameter, the circuit must be out of service.                                                       | Refer to the error message text.                                                                                                                                                                        |
| EID-6274         | Unable to restore this database:<br>The software version cannot be obtained from the node. Please try again.                                                                        | The user tries to restore a database on a node, but its not possible to get the software version from it.                                                                                               |
| EID-6275         | You cannot change this parameter.<br>The port is part of an active circuit.                                                                                                         | Certain parameters like Port Rate and Admin State cannot be changed when the port is part is part of an active circuit.<br>Delete all the circuits on the port before changing admin state of the port. |
| EID-6276         | APC is disabled. APC Correction Skipped. Override cannot be performed.                                                                                                              | Refer to the error message text.                                                                                                                                                                        |
| EID-6277         | There are no alarm conditions available to run APC Correction Skipped Override.                                                                                                     | Refer to the error message text.                                                                                                                                                                        |
| EID-6278         | APC Correction Skipped Override is not supported for this card.                                                                                                                     | Refer to the error message text.                                                                                                                                                                        |
| EID-6279         | Protection cannot be disabled when the FPAS alarm is active.                                                                                                                        | Refer to the error message text.                                                                                                                                                                        |
| WID-6280         | Any configuration change will be lost and the operation is traffic affecting.                                                                                                       | Refer to the error message text.                                                                                                                                                                        |

**Table 4-1** Error Messages (continued)

| <b>Error/Warning ID</b> | <b>Error/Warning Message</b>                                                                                                                                                                                       | <b>Description</b>                                                                                  |
|-------------------------|--------------------------------------------------------------------------------------------------------------------------------------------------------------------------------------------------------------------|-----------------------------------------------------------------------------------------------------|
| EID-6281                | The port is involved in a protection group.<br>The protected port is not in the {0} administrative state                                                                                                           | Change the port state to administrative.                                                            |
| WID-6282                | Forcing FPGA update will be traffic-affecting.                                                                                                                                                                     | Refer to the error message text.                                                                    |
| WID-6283                | Enabling ALS on a DWDM trunk port that is connected to a channel filter will result in a conflict with the ALS on the amplifier card or with the VOA startup process. Is it OK to continue?                        | Refer to the error message text.                                                                    |
| WID-6284                | Changing the timing standard will re-initialize the shelf timing and might affect traffic.<br><br>OK to continue?                                                                                                  | Refer to the error message text.                                                                    |
| WID-6285                | Since you are changing the IP address of one node containing some PPC terminations, you are also requested to run the PPC Repair tool in order to fix the IP addresses stored in the nodes connected by these PPCs | Refer to the error message text.                                                                    |
| EID-6286                | The port type cannot be changed because the port has been deleted.                                                                                                                                                 | Refer to the error message text.                                                                    |
| EID-6287                | You cannot edit the {0} {1}.                                                                                                                                                                                       | Port rate of Optical and Electrical ports cannot be changed while circuits are provisioned on them. |
| EID-6288                | The BERT configuration is invalid.                                                                                                                                                                                 | Refer to the error message text.                                                                    |
| EID-6289                | The BERT mode is not yet configured                                                                                                                                                                                | Refer to the error message text.                                                                    |
| WID-6290                | The BERT mode is configured in unframed format                                                                                                                                                                     | Refer to the error message text.                                                                    |
| WID-6291                | Port has circuits; configuring the BERT mode will disrupt normal traffic.                                                                                                                                          | Refer to the error message text.                                                                    |
| EID-6292                | The alarm type name cannot exceed 20 characters                                                                                                                                                                    | Refer to the error message text.                                                                    |
| EID-6294                | The alarm type name contains invalid characters.<br>Only the following characters are valid: 0-9, A-z, a-z and "-".                                                                                                | Refer to the error message text.                                                                    |
| EID-6295                | The alarm type is in use and cannot be deleted.                                                                                                                                                                    | Refer to the error message text.                                                                    |
| EID-6296                | Maximum number of alarm types that can be added cannot exceed 50.                                                                                                                                                  | Refer to the error message text.                                                                    |
| EID-6297                | Hard coded alarm types cannot be deleted.                                                                                                                                                                          | Refer to the error message text.                                                                    |
| EID-6298                | The alarm type already exists.                                                                                                                                                                                     | Refer to the error message text.                                                                    |
| EID-6299                | The alarm type does not exist.                                                                                                                                                                                     | Refer to the error message text.                                                                    |
| EID-6300                | Selective auto negotiation is allowed only when selected speed and duplex modes are non-auto.<br>Click "Reset" to revert the changes.                                                                              | Refer to the error message text.                                                                    |
| WID-6301                | Selective auto negotiation applies only to copper SFPs.                                                                                                                                                            | Refer to the error message text.                                                                    |

Table 4-1 Error Messages (continued)

| Error/Warning ID | Error/Warning Message                                                                                                                                                              | Description                                                                 |
|------------------|------------------------------------------------------------------------------------------------------------------------------------------------------------------------------------|-----------------------------------------------------------------------------|
| EID-6302         | Users are not allowed to perform this operation.                                                                                                                                   | When logged in as a maintenance user provisioning operation is not allowed. |
| EID-6303         | The ITU-T G.709 configuration cannot be disabled when Fast Protection is enabled.                                                                                                  | Refer to the error message text.                                            |
| EID-6304         | Users are not allowed to perform this operation.                                                                                                                                   | Refer to the error message text.                                            |
| EID-6305         | The view could not be deleted.                                                                                                                                                     | Refer to the error message text.                                            |
| EID-6306         | The ITU-T G.709 configuration cannot be disabled when Fast Protection is enabled.                                                                                                  | Refer to the error message text.                                            |
| WID-6307         | You have only selected one trunk-to-trunk patchcord. For complete deletion, you must select both patchcords that are attached to the 10GE_XP/GE_XP cards. Do you want to continue? | Refer to the warning message text.                                          |
| WID-6308         | You have only selected one trunk-to-OCH patchcord. For complete deletion, you must select both patchcords that are attached to the TXP/MXP card. Do you want to continue?          | Refer to the warning message text.                                          |
| EID-6309         | OCHNC circuits, OSC terminations, synchronization sources and protection groups must be removed before you can remove this patchcord.                                              | Refer to the error message text.                                            |
| EID-6310         | The Committed Info Rate value must be in range [0-100].                                                                                                                            | Refer to the error message text.                                            |
| EID-6311         | The MTU value must be in range [64-9700].                                                                                                                                          | Refer to the error message text.                                            |
| EID-6312         | The multicast IP address must be in range [224.0.0.0 - 239.255.255.255] Excluding the following IP address subranges [(224-239).(0/128).0.(0-255)]                                 | Refer to the error message text.                                            |
| EID-6313         | The multicast IP address count must be in range [1-256]                                                                                                                            | Refer to the error message text.                                            |
| EID-6314         | Could not retrieve TTY session for the chosen CRS.                                                                                                                                 | Refer to the error message text.                                            |
| EID-6315         | CRS provisioning failed.<br>{0}                                                                                                                                                    | Refer to the error message text.                                            |
| EID-6316         | The chosen node is not a CRS-1.                                                                                                                                                    | Refer to the error message text.                                            |
| EID-6317         | The value specified for IPv6 Address or IPv6 Default Router is invalid.                                                                                                            | Refer to the error message text.                                            |
| EID-6318         | The value specified for Prefix Length is invalid. Valid range of values is 0 to 128.                                                                                               | Refer to the error message text.                                            |
| EID-6319         | IPv6 mode can be enabled only if SOCKS and firewall are enabled on the node.                                                                                                       | Refer to the error message text.                                            |
| EID-6320         | IPv6 mode cannot be enabled on a node if RIP is enabled.                                                                                                                           | Refer to the error message text.                                            |
| EID-6321         | IPv6 mode cannot be enabled on a node if 'OSPF on LAN' is enabled.                                                                                                                 | Refer to the error message text.                                            |
| EID-6322         | IPv6 Address cannot be specified for {0} when IPv6 mode is not enabled on the node.                                                                                                | Refer to the error message text.                                            |

Table 4-1 Error Messages (continued)

| Error/Warning ID | Error/Warning Message                                                                                                                                                                                                                                                                                                                                                                                                                                                                                          | Description                        |
|------------------|----------------------------------------------------------------------------------------------------------------------------------------------------------------------------------------------------------------------------------------------------------------------------------------------------------------------------------------------------------------------------------------------------------------------------------------------------------------------------------------------------------------|------------------------------------|
| EID-6323         | CTC was unable to delete SnmpV3 Target.                                                                                                                                                                                                                                                                                                                                                                                                                                                                        | Refer to the error message text.   |
| EID-6324         | The card mode is invalid in this configuration.                                                                                                                                                                                                                                                                                                                                                                                                                                                                | Refer to the error message text.   |
| EID-6325         | SW version mismatch on node {0}: found {1}, expected {2}.                                                                                                                                                                                                                                                                                                                                                                                                                                                      | Refer to the error message text.   |
| EID-6326         | The CRS node {0} version[{1}] is greater than the supported version[{2}]. The creation of ochtrail circuits between CRS nodes will not be disabled, but there could be unexpected behaviours.                                                                                                                                                                                                                                                                                                                  | Refer to the error message text.   |
| EID-6327         | The end point of patchcord have an incompatible wavelength.                                                                                                                                                                                                                                                                                                                                                                                                                                                    | Refer to the error message text.   |
| EID-6329         | Protection/AIS action cannot be both set to squelch.                                                                                                                                                                                                                                                                                                                                                                                                                                                           | Refer to the error message text.   |
| EID-6330         | The node failed to restart the Pseudo IOS CLI service on the selected port. Try using another unreserved port that is not being used within the 1024 - 65535 range.                                                                                                                                                                                                                                                                                                                                            | Refer to the error message text.   |
| EID-6331         | That port is already in use.<br>Also note that the Pseudo IOS port may not be changed if any Pseudo IOS connections are currently open.                                                                                                                                                                                                                                                                                                                                                                        | Refer to the error message text.   |
| WID-6332         | All previously configured IPv6 destinations will become unreachable if IPv6 mode is disabled. It is recommended that you remove all IPv6 related provisioning before disabling IPv6 mode.<br>Do you want to continue?                                                                                                                                                                                                                                                                                          | Refer to the warning message text. |
| WID-6333         | The NE default {0} not available in the selected NE Defaults Tree.                                                                                                                                                                                                                                                                                                                                                                                                                                             | Refer to the warning message text. |
| WID-6334         | Could not find the NE default {0}.                                                                                                                                                                                                                                                                                                                                                                                                                                                                             | Refer to the warning message text. |
| WID-6335         | CTC was unable to create a new Target account.                                                                                                                                                                                                                                                                                                                                                                                                                                                                 | Refer to the warning message text. |
| WID-6336         | Changing the card to EFEC mode will cause the ports 1 and 2 to be disabled.<br>Do you want to continue?                                                                                                                                                                                                                                                                                                                                                                                                        | Refer to the warning message text. |
| WID-6337         | CE-MR-10/CE-MR-6 card does not validate the Ethernet FCS when traffic is received from optical side. This can result in errored frames from optical side being forwarded to the peer device via front ports. It would be left to the peer device to detect the errors and discard the frames.<br>It is suggested to enable the FCS option on both ends of the circuit. The GFP FCS will be used to discard errored frames. The discarded frames will be accounted under the performance pane for the POS port. | Refer to the warning message text. |
| WID-6338         | Ingress COS setting is not compatible with QinQ mode.                                                                                                                                                                                                                                                                                                                                                                                                                                                          | Refer to the warning message text. |
| WID-6339         | Some circuits may become partial as part of this upgrade and would need to be reconfigured.                                                                                                                                                                                                                                                                                                                                                                                                                    | Refer to the warning message text. |
| WID-6340         | One or more QinQ rules have not been deleted because they are not related to the current circuit.                                                                                                                                                                                                                                                                                                                                                                                                              | Refer to the warning message text. |
| WID-6341         | The Functional view on {0} is disabled.                                                                                                                                                                                                                                                                                                                                                                                                                                                                        | Refer to the warning message text. |

Table 4-1 Error Messages (continued)

| Error/Warning ID | Error/Warning Message                                                                                                                        | Description                        |
|------------------|----------------------------------------------------------------------------------------------------------------------------------------------|------------------------------------|
| WID-6342         | Changing the {0} settings might be traffic affecting.<br>Do you want to continue?                                                            | Refer to the warning message text. |
| WID-6343         | The selected file name is too long.<br>File names (including the full path) must be less than 254 characters.Please enter a valid file name. | Refer to the warning message text. |
| EID-6344         | It is detected a shelf mismatch condition.                                                                                                   | Refer to the error message text.   |
| EID-6345         | The line termination is invalid.                                                                                                             | Refer to the error message text.   |
| EID-6346         | The overhead is not supported.                                                                                                               | Refer to the error message text.   |
| EID-6347         | A patchcord was expected for a successful operation.                                                                                         | Refer to the error message text.   |
| EID-6348         | A Virtual link already exists on the same path.                                                                                              | Refer to the error message text.   |
| EID-6349         | The overhead creation has failed.                                                                                                            | Refer to the error message text.   |
| EID-6350         | The unprotected line is not present                                                                                                          | Refer to the error message text.   |
| EID-6351         | The port status is active.                                                                                                                   | Refer to the error message text.   |
| EID-6352         | IPv4 access cannot be disabled when IPv6 mode is not enabled on the node.                                                                    | Refer to the error message text.   |
| EID-6353         | IPv4 access cannot be disabled when the node is in Multishelf configuration.                                                                 | Refer to the error message text.   |
| EID-6354         | Disabling IPv4 access may lead to loss of communication with the node.<br>Make the change anyway?                                            | Refer to the error message text.   |
| EID-6355         | IPv6 access cannot b disabled when IPv4 Access is disabled on the node.                                                                      | Refer to the error message text.   |
| EID-6356         | Multishelf configuration cannot be enabled when IPv4 Access is disabled on the node.                                                         | Refer to the error message text.   |
| EID-6357         | The Multicast SVLAN field can be modified only when the MVR feature is disabled.                                                             | Refer to the error message text.   |
| EID-6358         | Too many TRANSLATE QinQ rules per port with MVR feature enabled.                                                                             | Refer to the error message text.   |

1. EID-3159 can appear if you attempt to perform another switching operation within a certain time interval. This interval is an algorithm of three seconds per working card in the protection group. The maximum interval is 10 seconds.



## INDEX

---

### Numerics

- 1+1 protection
  - APS channel byte failure [2-32](#)
  - APS invalid code condition [2-33](#)
  - optimized 1+1 APS primary facility condition [2-34](#)
- 1+1 protection Force switch. *See* external switching commands
- 2R logical object [2-14](#)

---

### A

- ADMIN-DISABLE [3-4](#)
- ADMIN-DISABLE-CLR [3-4](#)
- ADMIN-LOCKOUT [3-4](#)
- ADMIN-LOCKOUT-CLR [3-4](#)
- ADMIN-LOGOUT [3-4](#)
- ADMIN-SUSPEND [3-4](#)
- ADMIN-SUSPEND-CLR [3-5](#)
- AICI-AEP logical object [2-14](#)
- AICI-AIE logical object [2-15](#)
- AIP
  - logical object [2-15](#)
  - MAC address location [2-114](#)
  - MEA [2-157](#)
  - replace [2-250](#)
- air filter
  - cleaning [2-247](#)
  - inspecting [2-247](#)
  - replacing [2-246](#)
- AIS
  - AIS [2-26](#)
  - AIS-L [2-27](#)
  - AIS-P [2-27](#)
  - AU-AIS [2-38](#)
  - AUTOSW-AIS [2-41](#)
  - AUTOSW-AIS-SNCP [2-41](#)
  - MS-AIS [2-163](#)
  - ODUK-1-AIS-PM [2-167](#)
  - ODUK-2-AIS-PM [2-168](#)
  - ODUK-3-AIS-PM [2-168](#)
  - ODUK-4-AIS-PM [2-169](#)
  - ODUK-AIS-PM [2-169](#)
  - OTUK-AIS [2-179](#)
- alarm logical objects
  - index by alarm [2-16](#)
  - list [2-14](#)
- alarm profiles, using to mask alarms [2-57](#)
- alarms
  - alphabetical list [2-8](#)
  - list of Critical alarms [2-2](#)
  - list of Major alarms [2-2](#)
  - list of Minor alarms [2-3](#)
  - masking with alarm profiles [2-57](#)
  - states [2-25](#)
  - TL1 [2-1](#)
  - See also* alarm troubleshooting
  - See also* individual alarm names
- alarm troubleshooting
  - alarm-specific procedures [2-26 to 2-235](#)
  - frequently used procedures [2-236 to 2-252](#)
  - See also* troubleshooting
- ALS
  - ALS [2-28](#)
  - ALS-DISABLED [2-28](#)
  - Auto Restart mode (illustration) [1-63](#)

- disabling for the network [1-70](#)
- system behavior in DISABLE mode [1-70](#)
- AMI coding [2-126](#)
- amplifier power control. *See* APC
- AMPLI-INIT [2-28](#)
- AOTS logical object [2-15](#)
- APC
  - APC-CORR-SKIPPED [2-29](#)
  - APC-DISABLED [2-29](#)
  - APC-END [2-30](#)
  - APC-OUT-OF-RANGE [2-31](#)
  - check mechanism [1-76, 1-78](#)
- APSB [2-32](#)
- APSCM [2-32](#)
- APSIMP [2-33](#)
- APS-INV-PRIM [2-34](#)
- APSM [2-34](#)
- APS-PRIM-FAC [2-35](#)
- APS-PRIM-SEC-MISM [2-35](#)
- AS-CMD [2-36](#)
- AS-MT [2-37](#)
- AU-AIS [2-38](#)
- AUD-ARCHIVE-FAIL [3-5](#)
- AU-LOP [2-38](#)
- AUTOLSROFF [2-39](#)
- automatic protection switching
  - byte failure [2-32](#)
  - channel mismatch [2-33](#)
  - mode mismatch failure [2-34](#)
  - path protection alarms [2-42, 2-44, 2-45, 2-46](#)
  - path protection switch (condition) [2-43](#)
  - SNCP alarms [2-42](#)
  - SNCP switch (condition) [2-43](#)
- automatic reset [2-40](#)
- AUTORESET [2-40](#)
- AUTOSW-AIS [2-41](#)
- AUTOSW-AIS-SNCP [2-41](#)
- AUTOSW-LOP (STSMON) [2-42](#)
- AUTOSW-LOP-SNCP [2-42](#)

- AUTOSW-PDI [2-43](#)
- AUTOSW-PDI-SNCP [2-43](#)
- AUTOSW-SDBER [2-44](#)
- AUTOSW-SDBER-SNCP [2-44](#)
- AUTOSW-SFBER [2-45](#)
- AUTOSW-SFBER-SNCP [2-45](#)
- AUTOSW-UNEQ (STSMON) [2-46](#)
- AUTOSW-UNEQ-SNCP (VCMON-HP) [2-46](#)
- AUTOWDMANS [3-5](#)
- AWG-DEG [2-47](#)
- AWG-FAIL [2-48](#)
- AWG-OVERTEMP [2-48](#)
- AWG-WARM-UP [2-49](#)

---

## B

- B8ZS [2-126](#)
- BAT-FAIL [2-49](#)
- BBE thresholds
  - provisioning [1-28](#)
  - setting node defaults [1-27](#)
- BER
  - signal degrade condition [2-182](#)
  - signal degrade PM condition [2-172](#)
  - signal fail condition [2-183](#)
  - signal fail PM condition [2-172](#)
  - verifying threshold level [2-244](#)
- bit error rate. *See* BER
- bit errors [1-56](#)
- BITS
  - daisy-chained [1-55](#)
  - errors [1-54](#)
  - holdover timing [1-54](#)
  - logical object [2-15](#)
  - loss of frame [2-126](#)
  - loss of signal [2-134](#)
- BKUPMEMP [2-49](#)
- blinking STAT LED [1-55](#)
- BLSR



- BLSR-RESYNC transient condition [3-5](#)
  - change node ID number [2-236](#)
  - change ring name [2-236](#)
  - manual span condition [2-157](#)
  - verify node visibility [2-237](#)
  - BPLANE logical object [2-15](#)
  - BPV [2-50](#)
  - browsers
    - does not launch Java [1-40](#)
    - reconfiguring [1-41](#)
    - resetting [1-44](#)
    - stalls during download [1-46](#)
    - supported in this release [1-38](#)
    - unsupported in this release [1-39](#)
- 
- ## C
- calculating IP subnets [1-53](#)
  - cards
    - behavior during facility loopbacks [1-3](#)
    - behavior during terminal loopbacks [1-6](#)
    - removing [2-243](#)
    - replacing [2-244](#)
    - reseating [2-243](#)
    - resetting [2-241](#)
    - See also* DWDM cards
    - See also* MXP cards
    - See also* TCC2 card
    - See also* TCC2P card
    - See also* TXP cards
  - CARLOSS
    - CARLOSS (EQPT) [2-51](#)
    - CARLOSS (FC) [2-53](#)
    - CARLOSS (GE) [2-53](#)
    - CARLOSS (ISC) [2-54](#)
    - CARLOSS (TRUNK) [2-55](#)
  - CASETEMP-DEG [2-56](#)
  - CAT-5 cable, crimping [1-57](#)
  - CHANLOSS, description [2-57](#)
  - circuits
    - clearing an STM-N cross-connect loopback [2-246](#)
    - deleting [2-245](#)
    - generic procedures [2-244](#)
    - path-in-use error [1-53](#)
    - See also* OCHNC circuits
  - CLDRESTART [2-57](#)
  - cleaning the air filter [2-247](#)
  - clearing
    - 1+1 Force or Manual switch [2-238](#)
    - lock-on or lockout [2-240](#)
    - MXP card loopbacks [2-245](#)
    - MXP card signal loss [2-209](#)
    - Netscape Navigator cache [1-47](#)
    - STM-N card cross-connect loopback circuit [2-246](#)
    - TXP card loopbacks [2-245](#)
    - TXP card signal loss [2-209](#)
  - conditions
    - characteristics [2-24](#)
    - list of Not Alarmed conditions [2-5](#)
    - list of Not Reported conditions [2-8](#)
    - See also* individual condition names
  - CONTBUS-DISABLED [2-58](#)
  - CONTBUS-IO-A [2-59](#)
  - CONTBUS-IO-B [2-60](#)
  - CRC [2-50](#)
  - creating
    - RS-DCC terminations [2-246](#)
  - creating DCC terminations [2-245](#)
  - Critical alarm list [2-2](#)
  - cross-connect loopback
    - clearing [2-246](#)
  - CTC
    - applet not loaded [1-40](#)
    - deleting cache files [1-48 to 1-49](#)
    - grey node icon [1-50](#)
    - launching to correct the core version build [1-51, 1-52](#)
    - launch problems [1-47](#)
    - list of alarms [2-1](#)

log-in errors [1-40](#), [1-46](#), [1-52](#)  
 loss of TCP/IP connection [2-51](#)  
 minimum workstation requirements [1-38](#)  
 release interoperability problems [1-51](#)  
 resetting a card in [2-241](#)  
 slow operation or login problems [1-47](#)  
 username and password mismatch [1-52](#)  
 verifying PC connection [1-42](#)

CTNEQPT-MISMATCH [2-61](#)  
 cyclic redundancy checking. *See* CRC

---

## D

database  
   memory exceeded [2-62](#)  
   out of synchronization [2-62](#)  
   restoring default settings [1-37](#)  
   verify version [2-250](#)

data communications network. *See* DCN tool

DATAFLT [2-62](#)  
 DBBACKUP-FAIL [3-5](#)  
 DBOSYNC [2-62](#)  
 DBRESTORE-FAIL [3-5](#)

DCC  
   channel loss [2-69](#), [2-71](#), [2-164](#), [2-198](#)  
   connection loss [1-53](#)  
   creating or verifying DCC terminations [2-245](#)  
   creating RS-DCC terminations [2-246](#)  
   deleting a DCC termination [2-111](#)  
   verifying RS-DCC terminations [2-246](#)

DCN tool [1-36](#)

DCU  
   loss [2-63](#)

deleting  
   circuits [2-245](#)  
   CTC cache files [1-48 to 1-49](#)  
   DCC termination [2-111](#)

designing IP subnets [1-53](#)  
 diagnostic tests

  retrieve [1-34](#)

disabling  
   ALS for the network [1-70](#)  
   VirusScan [1-46](#)

DISCONNECTED [2-63](#)

documentation  
   audience [xxxiii](#)  
   conventions [xxxiv](#)  
   objectives [xxxii](#)  
   related to this book [xxxiii](#)

DSP-COMM-FAIL [2-64](#)  
 DSP-FAIL [2-64](#)  
 DUP-IPADDR [2-65](#)  
 DUP-NODENAME [2-65](#)  
 DUP-SHELF-ID [2-66](#)

DWDM cards  
   LED activity [2-234](#)  
   OCH alarm object [2-15](#)  
   OCHNC-CONN alarm object [2-15](#)  
   troubleshooting circuits with ITU-T G.709  
   monitoring [1-25](#)

---

## E

EHIBATVG [2-66](#)

EIAs, facility loopback test [1-3](#)

electrical cards  
   failure to switch condition [2-77](#)  
   initiating a protection switch [2-238](#)

ELWBATVG [2-67](#)  
 ENCAP-MISMATCH-P [2-67](#)  
 ENVALRM logical object [2-15](#)

EOC  
   EOC [2-69](#)  
   EOC-L [2-71](#)  
   GCC-EOC [2-92](#)  
   MS-EOC [2-163](#)

EQPT  
   EQPT alarm [2-72](#)

- EQPT-DIAG [2-73](#)
  - EQPT-MISS alarm [2-74](#)
  - logical object [2-15](#)
  - equipment failure
    - hardware failure on reporting card [2-72](#)
    - missing fan-tray assembly [2-74](#)
    - software or hardware failure on reporting card [2-73](#)
  - ERFI-P-CONN [2-74](#)
  - ERFI-P-SRVR [2-75](#)
  - error messages [4-1 to 4-54](#)
  - ESCON logical object [2-15](#)
  - EXCCOL [2-75](#)
  - excess collisions [2-75](#)
  - EXERCISING-RING [3-6](#)
  - EXERCISING-SPAN [3-6](#)
  - EXT [2-75](#)
  - external switching commands
    - clear a BLSR switching command [2-240](#)
    - clearing a 1+1 Force or Manual switch [2-238](#)
    - clearing a lock-on or lockout [2-240](#)
    - disabled condition [2-111](#)
    - initiate a BLSR lockout [2-240](#)
    - initiating a 1+1 Manual switch [2-237](#)
    - initiating a 1+1 protection switch [2-237](#)
    - initiating a 1:1 protection switch [2-238](#)
    - initiating a lock-on [2-239](#)
    - initiating a lockout [2-239](#)
  - EXT-SREF logical object [2-15](#)
- 
- F**
- facility loopback
    - card behavior [1-3](#)
    - definition [1-2](#)
    - performing on destination-node ports [1-19](#)
    - performing on intermediate-node ports [1-14](#)
    - performing on source-node ports [1-8](#)
  - FAILTOSW
    - FAILTOSW (2R, EQPT, ESCON, FC, GE, ISC, OCN/STMN) [2-76](#)
    - FAILTOSW (TRUNK) [2-77](#)
    - FAILTOSW-HO [2-77](#)
    - FAILTOSW-PATH [2-78](#)
    - FAN
      - alarm [2-78](#)
      - logical object [2-15](#)
    - fan-tray assembly
      - MEA [2-159](#)
      - missing unit alarm [2-74](#)
      - removing [2-248](#)
      - replacing [2-249](#)
      - reseating [2-248](#)
    - FAPS [2-79](#)
    - FAPS-CONFIG-MISMATCH [2-79](#)
    - FC\_MR-4 card
      - GFP client signal fail detected alarm [2-95](#)
    - FC logical object [2-15](#)
    - FC-NO-CREDITS [2-80](#)
    - FDI [2-81](#)
    - FEC
      - description [1-30](#)
      - provisioning thresholds [1-31](#)
    - FEC-MISM [2-84](#)
    - FE-FRCDWKSWBK-SPAN [2-82](#)
    - FE-FRCDWKSWPR-SPAN [2-82](#)
    - FE-MANWKSWBK-SPAN [2-83](#)
    - FE-MANWKSWPR-SPAN [2-83](#)
    - FEPRLF [2-85](#)
    - fiber and cabling errors [1-56](#)
    - fiber cut
      - detecting [1-61 to 1-68](#)
      - fixing [1-68](#)
      - restarting system after [1-70 to 1-80](#)
    - fiber-optic connections [1-56](#)
    - FIBERTEMP-DEG [2-85](#)
    - firewall, invalid port number [4-12](#)
    - FIREWALL-DIS [3-6](#)

flash manager [2-49](#)  
 flow rate [2-75](#)  
 FORCED-REQ [2-86](#)  
 FORCED-REQ-SPAN [2-86, 2-87](#)  
 forward error correction. *See* FEC  
 FP-LINK-LOSS [2-87](#)  
 FRCDSWTOINT [2-87](#)  
 FRCDSWTOPRI [2-88](#)  
 FRCDSWTOSEC [2-88](#)  
 FRCDSWTOTHIRD [2-88](#)  
 FRCDWKSWBK-NO-TRFSW [3-6](#)  
 FRCDWKSWPR-NO-TRFSW [3-6](#)  
 free run synchronization [2-88](#)  
 FRNGSYNC [1-55, 2-88](#)  
 FSTSYNC [2-89](#)  
 FTA-MISMATCH [2-89](#)

---

## G

G.709 monitoring. *See* ITU-T G.709 monitoring  
 GAIN-HDEG [2-90](#)  
 GAIN-HFAIL [2-91](#)  
 GAIN-LDEG [2-91](#)  
 GAIN-LFAIL [2-92](#)  
 GBICs. *See* SFPs and XFPs  
 GCC-EOC [2-92](#)  
 GE logical object [2-15](#)  
 GE-OOSYNC (FC, GE, ISC) [2-93](#)  
 GE-OOSYNC (TRUNK) [2-94](#)  
 GFP  
   encapsulation mismatch [2-67](#)  
   GFP-CSF [2-94](#)  
   GFP-LFD [2-95](#)  
   GFP-UP-MISMATCH [2-96](#)

---

## H

HD-DEG

  alarm [2-103](#)  
 HELLO [2-96](#)  
 HIBATVG [2-97](#)  
 HI-CCVOLT [2-97](#)  
 HI-LASERBIAS [2-98](#)  
 HI-LASERTEMP [2-98](#)  
 HI-RXPOWER [2-99](#)  
 HITEMP [2-100](#)  
 HI-TXPOWER [2-101](#)  
 HLDOVRSYNC [1-54, 2-102](#)  
 HP-ENCAP-MISMATCH [2-104](#)  
 HP-EXC  
   alarm [2-105](#)  
 HP-RFI [2-106](#)  
 HP-TIM [2-106](#)  
 HP-UNEQ [2-107](#)

---

## I

I-HITEMP [2-109](#)  
 ILK-FAIL [2-109](#)  
 improper card removal [2-110](#)  
 IMPROPRMVL [2-109](#)  
 INCOMPATIBLE-SEND-PDIP [2-112](#)  
 INCOMPATIBLE-SW [1-51, 2-113](#)  
 INHSWPR [2-111](#)  
 INHSWWKG [2-112](#)  
 inspecting the air filter [2-247](#)  
 installing  
   SFPs [1-59](#)  
   XFPs [1-59](#)  
 Internet Explorer, resetting as default browser [1-44](#)  
 internode problems  
   network level [1-61](#)  
   node level [1-85](#)  
 interoperability [1-51](#)  
 INTRUSION [3-6](#)  
 INTRUSION-PSWD [2-113, 3-7](#)  
 INVMACADR [2-114](#)

IOSCFG-COPY-FAIL [3-7](#)  
 IP address, retrieving unknown [1-43](#)  
 IP connectivity  
   IP address unknown [1-43](#)  
   verifying (ping) [1-42](#)  
 IP subnets  
   calculating [1-53](#)  
   designing [1-53](#)  
 ISC logical object [2-15](#)  
 ISIS-ADJ-FAIL [2-116](#)  
 ITU-T G.709 monitoring  
   common trouble scenarios [1-31](#)  
   description [1-25](#)  
   provisioning thresholds [1-28](#)

## J

Java  
   browser does not launch [1-40](#)  
   Java Runtime Environment. *See* JRE  
   reconfiguring Java Plug-in control panel [1-40](#)  
 JRE  
   compatibility by software release [1-50](#)  
   incompatibility [1-50](#)  
   launch failure [1-40](#)  
   supported in this release [1-38](#)  
   unsupported in this release [1-39](#)

## L

lamp test [1-33](#)  
 LAN cable, crimping [1-57](#)  
 LASER-APR [2-117](#)  
 LASERBIAS-DEG [2-118](#)  
 LASERBIAS-FAIL [2-118](#)  
 LASEREOL [2-119](#)  
 LASERTEMP-DEG [2-120](#)  
 LED

blinking STAT LED [1-55](#)  
 testing [1-33](#)  
 traffic card after reset [2-235](#)  
 traffic card during reset [2-235](#)  
 traffic card insertion [2-235](#)  
 line coding [2-126](#)  
 line framing [2-126](#)  
 line interface unit [1-3](#)  
 LMP  
   LMP-FAIL [2-120](#)  
   LMP-SD [2-122](#)  
   LMP-SF [2-122](#)  
   LMP-UNALLOC [2-124](#)  
 lock initiation [2-237](#)  
 lock-on. *See* external switching commands  
 lockout. *See* external switching commands  
 LOCKOUT-REQ [2-124](#)  
 LOCKOUT-REQ (2R, EQPT, ESCON, FC, GE, ISC) [2-125](#)  
 LOCKOUT-REQ (TRUNK) [2-125](#)  
 LOF  
   LOF (BITS) [2-126](#)  
   LOF (TRUNK) [2-127](#)  
   OTUK-LOF [2-181](#)  
   suppressed TCAs [1-26, 2-127, 2-137, 2-146](#)  
 LOGBUF90 [2-128](#)  
 LOGBUFROVFL [2-128](#)  
 logical objects  
   index by alarm [2-16](#)  
   list [2-14](#)  
 log-in errors  
   browser login does not launch Java [1-40](#)  
   browser stalls when downloading JAR file [1-46](#)  
   no DCC connection [1-53](#)  
   slow CTC operation [1-47](#)  
   username/password mismatch [1-52](#)  
 LOGIN-FAILURE-LOCKOUT [3-7](#)  
 LOGIN-FAILURE-ONALRDY [3-7](#)  
 LOGIN-FAILURE-PSWD [3-7](#)

LOGIN-FAILURE-USERID [3-7](#)

LOGOUT-IDLE-USER [3-8](#)

LO-LASERBIAS [2-128](#)

LO-LASERTEMP [2-129](#)

LOM [2-130](#)

loopback

alarms [2-152, 2-154](#)

*See also* facility loopback

*See also* terminal loopback

LOP

AU-LOP [2-38](#)

AUTOSW-LOP [2-42](#)

AUTOSW-LOP-SNCP [2-42](#)

LOP-P [2-131](#)

LO-RXPOWER [2-132](#)

LOS

LOS (2R) [2-133](#)

LOS (BITS) [2-134](#)

LOS (ESCON) [2-134](#)

LOS (ISC) [2-135](#)

LOS (OTS) [2-136](#)

LOS (TRUNK) [2-136](#)

LOS-O [2-138](#)

LOS-P [1-92, 1-94, 1-102](#)

LOS-P (AOPTS, OMS, OTS) [2-139](#)

LOS-P (OCH) [2-142](#)

LOS-P (TRUNK) [2-145](#)

suppressed TCAs [1-26, 2-127, 2-137, 2-146](#)

loss of pointer. *See* LOP

loss of pointer *see* LOP

LO-TXPOWER [2-148](#)

LPBKCRS [2-149](#)

LPBKFACILITY

LPBKFACILITY (ESCON) [2-149](#)

LPBKFACILITY (FC) [2-150](#)

LPBKFACILITY (GE) [2-150](#)

LPBKFACILITY (ISC) [2-151](#)

LPBKFACILITY (TRUNK) [2-152](#)

LPBKTERMINAL

LPBKTERMINAL (ESCON) [2-152](#)

LPBKTERMINAL (FC) [2-152](#)

LPBKTERMINAL (GE) [2-153](#)

LPBKTERMINAL (ISC) [2-154](#)

LPBKTERMINAL (TRUNK) [2-154](#)

LWBATVG [2-155](#)

---

## M

MAC address

CTC location [2-251](#)

invalid [2-114](#)

Major alarm list [2-2](#)

MAN-REQ [2-155](#)

MANRESET [2-155](#)

MANSWTOINT [2-156](#)

MANSWTOPRI [2-156](#)

MANSWTOSEC [2-156](#)

MANSWTOTHIRD [2-156](#)

MANUAL-REQ-SPAN (2R, ESCON, FC, GE, ISC, OCN/STMN) [2-156](#)

MANUAL-REQ-SPAN (TRUNK) [2-157](#)

MANWKSWBK-NO-TRFSW [3-8](#)

MANWKSWPR-NO-TRFSW [3-8](#)

MEA

AIP [2-157](#)

MEA (EQPT) [2-157](#)

MEA (FAN) [2-159](#)

MEA (PPM) [2-160](#)

MEM-GONE [2-161](#)

MEM-LOW [2-161](#)

MFGMEM [2-162](#)

Minor alarm list [2-3](#)

ML-Series Ethernet cards

C2 byte mismatched path [2-67, 2-104](#)

GFP client signal fail detected [2-95](#)

MS-AIS

condition [2-163](#)

MS-DCC. *See* DCC

MS-DEG [2-163](#)  
 MS-EOC [2-163](#)  
 MS-EXC [2-164](#)  
 MS-RFI [2-164](#)  
 MSSP-RESYNC [3-8](#)  
 MS-SPRing  
     far-end protection line failure [2-85](#)  
 MT-OCHNC [2-165](#)  
 muxponder cards. *See* MXP cards  
 MXP cards  
     clearing loopbacks [2-245](#)  
     facility loopback behavior [1-4](#)  
     performing a facility loopback on [1-8, 1-14, 1-19](#)  
     performing a terminal loopback on [1-11, 1-17, 1-22](#)  
     signal loss [2-209](#)  
     TCAs suppressed by LOS and LOP alarms [1-26, 2-127, 2-137, 2-146](#)  
     terminal loopback behavior [1-6](#)  
     troubleshooting circuits with loopbacks [1-7](#)  
     wavelength mismatch [2-233](#)

## N

NE logical object [2-15](#)  
 NE-SREF logical object [2-15](#)  
 Netscape Navigator  
     clearing cache [1-47](#)  
     limiting colors [1-44](#)  
 network-level internode problems [1-61](#)  
 network view, unable to change to [1-45](#)  
 NIC card [1-41](#)  
 node ID, identify [2-236](#)  
 node-level internode problems [1-85](#)  
 node view, unable to change from [1-45](#)  
 NON-CISCO-PPM [2-165](#)  
 NOT-AUTHENTICATED [1-52, 2-166](#)

## O

OCH layer [1-25](#)  
 OCH logical object [2-15](#)  
 OCHNC circuits  
     conditions after rebuild [1-76](#)  
     deletion alarm [2-166](#)  
     errors in creating [1-80 to 1-85](#)  
     failure conditions [1-81](#)  
     failure scenarios [1-83](#)  
     in partial state [1-72](#)  
     partial (illustration) [1-82](#)  
     prerequisites for successful creation [1-80](#)  
     related alarms [2-166](#)  
 OCHNC-CONN logical object [2-15](#)  
 OCHNC-INC [2-166](#)  
 OCHTERM-INC [2-167](#)  
 OCH-TERM logical object [2-15](#)  
 ODUK-1-AIS-PM [2-167](#)  
 ODUK-2-AIS-PM [2-168](#)  
 ODUK-3-AIS-PM [2-168](#)  
 ODUK-4-AIS-PM [2-169](#)  
 ODUK-AIS-PM [2-169](#)  
 ODUK-BDI-PM [2-170](#)  
 ODUK-LCK-PM [2-170](#)  
 ODUK-OCI-PM [2-171](#)  
 ODUK-SD-PM [2-171](#)  
 ODUK-SF-PM [2-172](#)  
 ODUK-TIM-PM [2-173](#)  
 OMS layer [1-26](#)  
 OMS logical object [2-15](#)  
 OPEN-SLOT [2-173](#)  
     optical channel layer. *See* OCH layer  
     optical drop power  
         lower than expected, corrective action [1-102](#)  
         lower than expected, description [1-100](#)  
     optical multiplex section layer. *See* OMS layer  
     optical power level  
         lower than expected [1-92, 1-94](#)

lower than minimum allowed [1-87](#)  
 optical transmission section layer. *See* OTS layer  
 optical transport networks [1-25](#)  
 OPTNTWMIS [2-174](#)  
 OPWR-HDEG [2-174](#)  
 OPWR-HFAIL [2-176](#)  
 OPWR-LDEG [1-93, 1-98, 1-101, 1-104, 2-177](#)  
 OPWR-LFAIL [2-178](#)  
 OSC-RING logical object [2-15](#)  
 OSPF  
   Disable OSPF check box [2-246](#)  
   HELLO alarm [2-96](#)  
 OSPF, DCN tool [1-36](#)  
 OSRION [2-178](#)  
 OTS layer [1-26](#)  
 OTS logical object [2-15](#)  
 OTUK-AIS [2-179](#)  
 OTUK-BDI [2-179](#)  
 OTUK-IAE [2-180](#)  
 OTUK-LOF [2-181](#)  
 OTUK-SD [2-182](#)  
 OTUK-SF [2-183](#)  
 OTUK-TIM [2-184](#)  
 OUT-OF-SYNC [2-184](#)

---

## P

PARAM-MISM [2-185](#)  
 password/username mismatch [1-52](#)  
 path protection configurations  
   AIS alarm [2-41](#)  
   failed switch path [2-78](#)  
   LOP alarm [2-42](#)  
   PDI alarm [2-43](#)  
   SD alarm [2-44](#)  
   signal failure alarm [2-45](#)  
 PDI  
   AUTOSW-PDI [2-43](#)  
   AUTOSW-PDI-SNCP [2-43](#)

PDI-P [2-186](#)  
 PEER-NORESPONSE [2-187](#)  
 performance monitoring  
   ITU-T G.709 optical transport network [1-26](#)  
   provisioning thresholds using TL1 [1-29](#)  
 ping [1-39, 1-42, 2-209](#)  
 PMI [2-188](#)  
 PM-TCA [3-8](#)  
 PORT-FAIL [2-189](#)  
 power  
   equipment power failure alarms [2-192 to 2-195](#)  
   low battery voltage alarm [2-155](#)  
   mismatch between control cards [2-232](#)  
   power supply problems [1-59](#)  
   power up problems [1-61](#)  
 PPM logical object [2-15](#)  
 PROTNA [2-189](#)  
 provisioning  
   BBE or SES thresholds [1-28](#)  
   FEC thresholds [1-31](#)  
   ITU-T G.709 thresholds [1-28](#)  
   optical TCA thresholds [1-30](#)  
   PM thresholds using TL1 [1-29](#)  
   TXP card BBE or SES thresholds [1-28](#)  
   TXP card ITU-T G.709 thresholds [1-28](#)

PROV-MISMATCH [2-190](#)

PS [3-8](#)

PTIM [2-192](#)

PWR-FAIL-A [2-192](#)

PWR-FAIL-B [2-193](#)

PWR-FAIL-RET-A [2-194](#)

PWR-FAIL-RET-B [2-194](#)

PWR logical object [2-16](#)

---

## R

reconfiguring

  browsers [1-41](#)

  Java Plug-in control panel [1-40](#)



- removing
    - cards [2-243](#)
    - fan-tray assembly [2-248](#)
    - SFP or XFP connectors [1-59](#)
    - TCC2/TCC2P cards [2-242](#)
  - replacing
    - air filter [2-246](#)
    - cards [2-244](#)
    - fan-tray assembly [2-249](#)
    - SFPs [1-58](#)
    - XFPs [1-58](#)
  - reseating
    - cards [2-243](#)
    - fan-tray assembly [2-248](#)
    - TCC2/TCC2P cards [2-242](#)
  - resetting
    - active TCC2/TCC2P card [2-241](#)
    - browsers [1-44](#)
    - cards [2-241](#)
    - Internet Explorer as the default browser [1-44](#)
  - restoring the node database [1-37](#)
  - retrieving
    - unknown node IP address [1-43](#)
  - RFI [2-195](#)
    - ERFI-P-CONN [2-74](#)
    - ERFI-P-SRVR [2-75](#)
    - HP-RFI [2-106](#)
    - MS-RFI [2-164](#)
    - RFI-L [2-196](#)
    - RFI-P [2-196](#)
  - RMON-ALARM [3-9](#)
  - RMON-RESET [3-9](#)
  - RS-DCC. *See* DCC
  - RS-TIM [2-200](#)
- 
- S**
- safety
    - summary [2-25](#)
  - warnings [xxxv to xxxix](#)
  - SD
    - AUTOSW-SDBER [2-44](#)
    - AUTOSW-SDBER-SNCP [2-44](#)
    - MS-DEG (STM1E) [2-163](#)
    - ODUK-SD-PM [2-171](#)
    - OTUK-SD [2-182](#)
    - SD (TRUNK) [2-201](#)
    - SDBER-EXCEED-HO [2-203](#)
    - SD-L [2-201](#)
    - SD-P [2-202](#)
    - SDBER-EXCEED-HO [2-203](#)
  - security
    - incorrect password condition [2-113](#)
    - invalid login username condition [3-6](#)
    - invalid password condition [3-7](#)
  - service-affecting alarms [2-25](#)
  - SESSION-TIME-LIMIT [3-9](#)
  - SES thresholds
    - provisioning [1-28](#)
    - setting node defaults [1-27](#)
  - setting node defaults [1-27](#)
  - SF
    - AUTOSW-SFBER [2-45](#)
    - AUTOSW-SFBER-SNCP [2-45](#)
    - MS-EXC (STM1E) [2-164](#)
    - ODUK-SF-PM [2-172](#)
    - OTUK-SF [2-183](#)
    - SF (TRUNK) [2-204](#)
    - SF-L [2-205](#)
    - SF-P [2-206](#)
  - SFPs
    - installing [1-59](#)
    - removing connectors [1-59](#)
    - replacing [1-58](#)
  - SFTWDOWN [2-206](#)
  - SFTWDOWN-FAIL [3-9](#)
  - SHELF-COMM-FAIL [2-206](#)
  - SHELF logical object [2-16](#)

SH-IL-VAR-DEG-HIGH [2-207](#)  
 SH-IL-VAR-DEG-LOW [2-207](#)  
 SHUTTER-OPEN [2-208](#)  
 SIGLOSS [2-208](#)  
 SNCP  
   PDI alarm [2-43](#)  
 SNTP-HOST [2-209](#)  
 span is gray in CTC [1-70](#)  
 SPANLEN-OUT-OF-RANGE [2-210](#)  
 SPAN-NOT-MEASURED [2-210](#)  
 SQUELCHED [2-210](#)  
 SSM  
   failure [2-213](#)  
   quality level degrade [2-212](#)  
   SSM-DUS [2-212](#)  
   SSM-FAIL [2-213](#)  
   SSM-LNC [2-213](#)  
   SSM-OFF [2-213](#)  
   SSM-PRC [2-214](#)  
   SSM-PRS [2-214](#)  
   SSM-RES [2-214](#)  
   SSM-SMC [2-214](#)  
   SSM-ST2 [2-215](#)  
   SSM-ST3 [2-215](#)  
   SSM-ST4 [2-215](#)  
   SSM-STU [2-216](#)  
   SSM-TNC [2-216](#)  
   synchronization traceability alarm [2-216](#)  
 STM-N cards  
   STM-64 temperature alarm [2-39](#)  
 STSMON  
   AUTOSW-LOP [2-42](#)  
   AUTOSW-UNEQ [2-46](#)  
 Sun systems. *See* UNIX  
 switching  
   *see* automatic protection switching  
   *see* external switching commands  
 SW-MISMATCH [2-216](#)  
 SWTDOWNFAIL [3-9](#)

SWTOPRI [2-217](#)  
 SWTOSEC [2-217](#)  
 SWTOTHIRD [2-217](#)  
 SYNC-FREQ [2-218](#)  
 synchronization status messaging. *See* SSM  
 SYNCLOSS [2-218](#)  
 SYNCPRI [2-219](#)  
 SYNCSEC [2-220](#)  
 SYNCTHIRD [2-220](#)  
 SYSBOOT [2-221](#)

---

## T

TCAs  
   common trouble scenarios [1-31](#)  
   ITU-T G.709 optical transport network [1-26](#)  
   provisioning optical TCA thresholds [1-30](#)  
   resolving BBE [1-32](#)  
   suppressed by LOS and LOP alarms [1-26, 2-127, 2-137, 2-146](#)  
 TCC2 cards  
   activating standby [2-241](#)  
   flash memory exceeded [2-62](#)  
   JAR file download problem [1-46](#)  
   power mismatch between [2-232](#)  
   removing [2-242](#)  
   reseating [2-242](#)  
   resetting [2-241](#)  
 TCC2P cards  
   activating standby [2-241](#)  
   flash memory exceeded [2-62](#)  
   JAR file download problem [1-46](#)  
   power mismatch between [2-232](#)  
   removing [2-242](#)  
   reseating [2-242](#)  
   resetting [2-241](#)  
 TCP/IP [1-42, 2-51](#)  
 Telcordia  
   signal degrade definition [2-201](#)

- signal failure definition [2-204](#)
- standards applicable to this book [xxxiv](#)
- temperature
  - fan-tray assembly alarm [2-78](#)
  - high-temperature alarm [2-100](#)
  - industrial high-temperature alarm [2-109](#)
  - STM-64 alarm [2-39](#)
- TEMP-MISM [2-221](#)
- terminal loopback
  - card behavior [1-6](#)
  - definition [1-5](#)
  - performing on destination-node ports [1-22](#)
  - performing on intermediate-node ports [1-17](#)
  - performing on source-node ports [1-11](#)
- testing card LED lamps [1-33](#)
- threshold crossing alert. *See* TCA
- thresholds, provisioning BBE or SES [1-28](#)
- TIM
  - HP-TIM [2-106](#)
  - ODUK-TIM-PM [2-173](#)
  - OTUK-TIM [2-184](#)
  - PTIM [2-192](#)
  - RS-TIM [2-200](#)
  - TIM [2-222](#)
  - TIM-MON [2-223](#)
  - TIM-P [2-223](#)
  - TIM-S [2-224](#)
- timing alarms
  - free running synchronization [2-88](#)
  - loss of primary reference [2-219](#)
  - loss of tertiary reference [2-220](#)
  - synchronization [2-102](#)
  - timing reference failure [2-89](#)
- timing reference
  - automatic switch to secondary source (condition) [2-217](#)
  - automatic switch to third timing source (condition) [2-217](#)
  - changing [2-111](#)
  - manual switch to internal source (condition) [2-156](#)
  - manual switch to primary source (condition) [2-156](#)
  - manual switch to second source (condition) [2-156](#)
  - manual switch to third source (condition) [2-156](#)
  - switch error [1-54](#)
- TL1 [1-29](#)
- TRAIL-SIGNAL-FAIL [2-225](#)
- transient conditions
  - alphabetical list [3-1 to 3-3](#)
  - characteristics [3-3](#)
  - states [3-3](#)
  - See also* individual transient condition names
- transients. *See* transient conditions
- transponder cards. *See* TXP cards
- troubleshooting
  - alarm characteristics [2-24](#)
  - conditions [2-24](#)
  - frequently used procedures [2-236 to 2-252](#)
  - general procedures [1-1 to 1-106](#)
  - MXP circuit paths with loopbacks [1-7](#)
  - service effect [2-25](#)
  - severities [2-24](#)
  - TXP circuit paths with loopbacks [1-7](#)
  - See also* alarm troubleshooting
  - See also* loopback
- TRUNK logical object [2-16](#)
- TX-LOF [2-228](#)
- TXP cards
  - clearing loopbacks [2-245](#)
  - facility loopback behavior [1-4](#)
  - performing a facility loopback on [1-8, 1-14, 1-19](#)
  - performing a terminal loopback on [1-11, 1-17, 1-22](#)
  - provisioning BBE or SES thresholds [1-28](#)
  - provisioning FEC thresholds [1-31](#)
  - provisioning ITU-T G.709 thresholds [1-28](#)
  - signal loss [2-209](#)
  - TCAs suppressed by LOS and LOP alarms [1-26, 2-127, 2-137, 2-146](#)
  - terminal loopback behavior [1-6](#)

troubleshooting circuits with loopbacks [1-7](#)  
 wavelength mismatch [2-233](#)

---

## U

UNC-WORD [2-225, 2-226](#)

### UNEQ

AUTOSW-UNEQ (STSMON) [2-46](#)

AUTOSW-UNEQ-SNCP [2-46](#)

HP-UNEQ [2-107](#)

### UNIX

incorrect colors [1-44](#)

minimum requirements for CTC [1-38](#)

UNQUAL-PPM [2-228](#)

USER-LOCKOUT [3-9](#)

USER-LOGIN [3-10](#)

USER-LOGOUT [3-10](#)

username/password mismatch [1-52](#)

UT-COMM-FAIL [2-228](#)

UT-FAIL [2-229](#)

---

## V

variable optical attenuation. *See* VOA

### verifying

BER threshold level [2-244](#)

CTC PC connection [1-42](#)

DCC terminations [2-245](#)

IP connectivity [1-42](#)

RS-DCC terminations [2-246](#)

username and password [1-52](#)

VirusScan, disabling [1-46](#)

### VOA

failure scenarios [1-87 to 1-106](#)

high degrade alarm [2-230](#)

high fail alarm [2-230](#)

low degrade alarm [2-231](#)

low fail alarm [2-231](#)

startup phases [1-85 to 1-87](#)

VOA-HDEG [2-230](#)

VOA-HFAIL [2-230](#)

VOA-LDEG [2-231](#)

VOA-LFAIL [2-231](#)

VOLT-MISM [2-232](#)

---

## W

### warnings

definition [xxxv](#)

Windows, minimum workstation requirements [1-38](#)

WKSWBK [3-10](#)

WKSWPR [3-10](#)

WKSWPR (2R, EQPT, ESCON, FC, GE, ISC) [2-232](#)

WKSWPR (TRUNK) [2-232](#)

WRMRESTART [3-10](#)

WTR (2R, EQPT, ESCON, FC, GE, ISC) [2-233](#)

WTR (TRUNK) [2-233](#)

WTR-SPAN [3-10](#)

WVL-MISMATCH [2-233](#)

---

## X

### XFPs

installing [1-59](#)

removing connectors [1-59](#)

replacing [1-58](#)