



CHAPTER 6

Provision Multiplexer and Demultiplexer Cards

This chapter describes legacy multiplexer and demultiplexer cards used in Cisco ONS 15454 dense wavelength division multiplexing (DWDM) networks and related procedures.

For card safety and compliance information, see the [Regulatory Compliance and Safety Information for Cisco CPT and Cisco ONS Platforms](#) document.



Note

Unless otherwise specified, “ONS 15454” refers to both ANSI and ETSI shelf assemblies.

Chapter topics include:

- [6.1 Card Overview, page 6-1](#)
- [6.2 Safety Labels, page 6-9](#)
- [6.3 32MUX-O Card, page 6-9](#)
- [6.3.5 Related Procedures for the 32MUX-O Card, page 6-13](#)
- [6.4 32DMX-O Card, page 6-14](#)
- [6.4.4 Related Procedures for the 32DMX-O Card, page 6-18](#)
- [6.5 4MD-xx.x Card, page 6-19](#)
- [6.5.5 Related Procedures for the 4MD-xx.x Card, page 6-23](#)



Note

For a description of the 32DMX, 32DMX-L, 40-DMX-C, 40-DMX-CE, 40-MUX-C, 40-WSS-C, 40-WSS-CE, and 40-WXC-C cards, see the “[Provision Reconfigurable Optical Add/Drop Cards](#)” chapter.

6.1 Card Overview

The card overview section contains card summary, compatibility, interface class, and channel allocation plan information for legacy multiplexer and demultiplexer cards.



Note

Each card is marked with a symbol that corresponds to a slot (or slots) on the ONS 15454 shelf assembly. The cards are then installed into slots displaying the same symbols. For a list of slots and symbols, see the “Card Slot Requirements” section in the [Cisco ONS 15454 Hardware Installation Guide](#).

6.1.1 Card Summary

Table 6-1 lists and summarizes the functions of the 32MUX-O, 32DMX-O, and 4MD-xx.x cards.

Table 6-1 Multiplexer and Demultiplexer Cards

Card	Port Description	For Additional Information
32MUX-O	The 32MUX-O has five sets of ports located on the faceplate. It operates in Slots 1 to 5 and 12 to 16.	See the “6.3 32MUX-O Card” section on page 6-9.
32DMX-O	The 32DMX-O has five sets of ports located on the faceplate. It operates in Slots 1 to 5 and 12 to 16.	“6.4 32DMX-O Card” section on page 6-14
4MD-xx.x	The 4MD-xx.x card has five sets of ports located on the faceplate. It operates in Slots 1 to 6 and 12 to 17.	See the “6.5 4MD-xx.x Card” section on page 6-19.

6.1.2 Card Compatibility

Table 6-2 lists the CTC software compatibility for the legacy cards.

Table 6-2 Software Compatibility for Legacy Multiplexer and Demultiplexer Cards

Release	Cards		
	32MUX-O	32DMX-O	4MD-xx.x
R4.5	Yes	Yes	Yes
R4.6	Yes	Yes	Yes
R4.7	Yes	Yes	Yes
R5.0	Yes	Yes	Yes
R6.0	Yes	Yes	Yes
R7.0	Yes	Yes	Yes
R7.2	Yes	Yes	Yes
R8.0	Yes	Yes	Yes
R8.5	Yes	Yes	Yes
R9.0	Yes	Yes	Yes
R9.1	Yes	Yes	Yes
R9.2	Yes	Yes	Yes
R9.2.1	Yes	Yes	Yes
R9.3	Yes	Yes	Yes
R9.4	Yes	Yes	Yes

6.1.3 Interface Classes

The 32MUX-O, 32DMX-O, and 4MD-xx.x cards have different input and output optical channel signals depending on the interface card where the input signal originates. The input interface cards have been grouped in classes listed in [Table 6-3](#). The subsequent tables list the optical performance and output power of each interface class.

Table 6-3 ONS 15454 Card Interfaces Assigned to Input Power Classes

Input Power Class	Card
A	10-Gbps multirate transponder cards (TXP_MR_10G, TXP_MR_10E, TXP_MR_10E_C, and TXP_MR_10E_L) with forward error correction (FEC) enabled, 10-Gbps muxponder cards (MXP_2.5G_10G, MXP_2.5G_10E, MXP_MR_10DME_C, MXP_MR_10DME_L, MXP_2.5G_10E_C, and MXP_2.5G_10E_L) with FEC enabled, 40-Gbps transponder cards (40E-TXP-C, and 40ME-TXP-C), and 40-Gbps muxponder cards (40G-MXP-C, 40E-MXP-C, and 40ME-MXP-C)
B	10-Gbps multirate transponder card (TXP_MR_10G) without FEC, 10-Gbps muxponder cards (MXP_2.5G_10G, MXP_MR_10DME_C, MXP_MR_10DME_L), 40-Gbps transponder cards (40E-TXP-C, and 40ME-TXP-C), 40-Gbps muxponder cards (40G-MXP-C, 40E-MXP-C, and 40ME-MXP-C), and ADM-10G cards with FEC disabled
C	OC-192 LR ITU cards (TXP_MR_10E, TXP_MR_10E_C, and TXP_MR_10E_L) without FEC
D	2.5-Gbps multirate transponder card (TXP_MR_2.5G), both protected and unprotected, with FEC enabled
E	OC-48 100-GHz DWDM muxponder card (MXP_MR_2.5G) and 2.5-Gbps multirate transponder card (TXP_MR_2.5G), protected or unprotected, with FEC disabled and retime, reshape, and regenerate (3R) mode enabled
F	2.5-Gbps multirate transponder card (TXP_MR_2.5G), protected or unprotected, in regenerate and reshape (2R) mode
G	OC-48 ELR 100 GHz card
H	2/4 port GbE transponder (GBIC WDM 100GHz)
I	TXP_MR_10E, TXP_MR_10E_C, and TXP_MR_10E_L, 40E-TXP-C, and 40ME-TXP-C cards with enhanced FEC (E-FEC) and the MXP_2.5G_10E, MXP_2.5G_10E_C, MXP_2.5G_10E_L, MXP_MR_10DME_C, MXP_MR_10DME_L, 40G-MXP-C, 40E-MXP-C, and 40ME-MXP-C cards with E-FEC enabled

[Table 6-5](#) lists the optical performance parameters for 40-Gbps cards that provide signal input to multiplexer and demultiplexer cards.

Table 6-4 40-Gbps Interface Optical Performance

Parameter	Class A		Class B		Class I	
	Power Limited	OSNR ¹ Limited	Power Limited	OSNR Limited	Power Limited	OSNR Limited
Maximum bit rate	40 Gbps		40 Gbps		40 Gbps	
Regeneration	3R		3R		3R	
FEC	Yes		No		Yes (E-FEC)	
Threshold	Optimum		Average		Optimum	
Maximum BER ²	10 ⁻¹⁵		10 ⁻¹²		10 ⁻¹⁵	
OSNR ¹ sensitivity	23 dB	9 dB	23 dB	19 dB	20 dB	8 dB
Power sensitivity	-24 dBm	-18 dBm	-21 dBm	-20 dBm	-26 dBm	-18 dBm
Power overload	-8 dBm		-8 dBm		-8 dBm	
Transmitted Power Range ³						
40-Gbps multirate transponder/40-Gbps EC transponder (40E-TXP-C and 40ME-TXP-C)	+2.5 to 3.5 dBm		+2.5 to 3.5 dBm		—	
OC-192 LR ITU	—		—		—	
Dispersion compensation tolerance	+/-800 ps/nm		+/-1,000 ps/nm		+/-800 ps/nm	

1. OSNR = optical signal-to-noise ratio

2. BER = bit error rate

3. These values, decreased by patchcord and connector losses, are also the input power values for the OADM cards.

Table 6-5 lists the optical performance parameters that provide signal input for the 40-Gbps multiplexer and demultiplexer cards.

Table 6-5 10-Gbps Interface Optical Performance Parameters

Parameter	Class A		Class B		Class C	Class I	
	Power Limited	OSNR ¹ Limited	Power Limited	OSNR Limited	OSNR Limited	Power Limited	OSNR Limited
Maximum bit rate	10 Gbps		10 Gbps		10 Gbps	10 Gbps	
Regeneration	3R		3R		3R	3R	
FEC	Yes		No		No	Yes (E-FEC)	
Threshold	Optimum		Average		Average	Optimum	
Maximum BER ²	10 ⁻¹⁵		10 ⁻¹²		10 ⁻¹²	10 ⁻¹⁵	
OSNR ¹ sensitivity	23 dB	9 dB	23 dB	19 dB	19 dB	20 dB	8 dB
Power sensitivity	-24 dBm	-18 dBm	-21 dBm	-20 dBm	-22 dBm	-26 dBm	-18 dBm

Table 6-5 10-Gbps Interface Optical Performance Parameters (continued)

Parameter	Class A		Class B		Class C	Class I	
	Power Limited	OSNR ¹ Limited	Power Limited	OSNR Limited	OSNR Limited	Power Limited	OSNR Limited
Power overload	-8 dBm		-8 dBm		-9 dBm	-8 dBm	
Transmitted Power Range ³							
10-Gbps multirate transponder/10-Gbps FEC transponder (TXP_MR_10G)	+2.5 to 3.5 dBm		+2.5 to 3.5 dBm		—	—	
OC-192 LR ITU	—		—		+3.0 to 6.0 dBm	—	
10-Gbps multirate transponder/10-Gbps FEC transponder (TXP_MR_10E)	+3.0 to 6.0 dBm		+3.0 to 6.0 dBm		—	+3.0 to 6.0 dBm	
Dispersion compensation tolerance	+/-800 ps/nm		+/-1,000 ps/nm		+/-1,000 ps/nm	+/-800 ps/nm	

1. OSNR = optical signal-to-noise ratio

2. BER = bit error rate

3. These values, decreased by patchcord and connector losses, are also the input power values for the OADM cards.

Table 6-6 lists the optical interface performance parameters for 2.5-Gbps cards that provide signal input to multiplexer and demultiplexer cards.

Table 6-6 2.5-Gbps Interface Optical Performance

Parameter	Class D		Class E		Class F	Class G		Class H		Class J
	Power Limited	OSNR Limited	Power Limited	OSNR Limited	OSNR Limited	Power Limited	OSNR Limited	Power Limited	OSNR Limited	Power Limited
Maximum bit rate	2.5 Gbps		2.5 Gbps		2.5 Gbps	2.5 Gbps		1.25 Gbps		2.5 Gbps
Regeneration	3R		3R		2R	3R		3R		3R
FEC	Yes		No		No	No		No		No
Threshold	Average		Average		Average	Average		Average		Average
Maximum BER	10 ⁻¹⁵		10 ⁻¹²		10 ⁻¹²	10 ⁻¹²		10 ⁻¹²		10 ⁻¹²
OSNR sensitivity	14 dB	6 dB	14 dB	10 dB	15 dB	14 dB	11 dB	13 dB	8 dB	12 dB
Power sensitivity	-31 dBm	-25 dBm	-30 dBm	-23 dBm	-24 dBm	-27 dBm	-33 dBm	-28 dBm	-18 dBm	-26 dBm
Power overload	-9 dBm		-9 dBm		-9 dBm	-9 dBm		-7 dBm		-17dBm

Table 6-6 2.5-Gbps Interface Optical Performance (continued)

Parameter	Class D		Class E		Class F	Class G		Class H		Class J
	Power Limited	OSNR Limited	Power Limited	OSNR Limited	OSNR Limited	Power Limited	OSNR Limited	Power Limited	OSNR Limited	Power Limited
Transmitted Power Range ¹										
TXP_MR_2.5G	-1.0 to 1.0 dBm		-1.0 to 1.0 dBm		-1.0 to 1.0 dBm	-2.0 to 0 dBm				
TXPP_MR_2.5G	-4.5 to -2.5 dBm		-4.5 to -2.5 dBm		-4.5 to -2.5 dBm					
MXP_MR_2.5G	—		+2.0 to +4.0 dBm		—					
MXPP_MR_2.5G	—		-1.5 to +0.5 dBm		—					
2/4 port GbE Transponder (GBIC WDM 100GHz)								+2.5 to 3.5 dBm		—
Dispersion compensation tolerance	-1200 to +5400 ps/nm		-1200 to +5400 ps/nm		-1200 to +3300 ps/nm	-1200 to +3300 ps/nm		-1000 to +3600 ps/nm		-1000 to +3200 ps/nm

1. These values, decreased by patchcord and connector losses, are also the input power values for the OADM cards.

6.1.4 Channel Allocation Plan

ONS 15454 DWDM multiplexer and demultiplexer cards are designed for use with specific channels in the C band and L band. In most cases, the channels for these cards are either numbered (for example, 1 to 32 or 1 to 40) or delimited (odd or even). Client interfaces must comply with these channel assignments to be compatible with the ONS 15454 system.

Table 6-7 lists the channel IDs and wavelengths assigned to the C-band DWDM channels.



Note

In some cases, a card uses only one of the bands (C band or L band) and some or all of the channels listed in a band. Also, some cards use channels on the 100-GHz ITU grid while others use channels on the 50-GHz ITU grid. See the specific card description or the “[Hardware Specifications](#)” document for more details.

Table 6-7 DWDM Channel Allocation Plan (C Band)

Channel Number	Frequency (THz)	Wavelength (nm)	Channel Number	Frequency (THz)	Wavelength (nm)
1	196.00	1529.55	42	193.95	1545.72
2	195.95	1529.94	43	193.90	1546.119
3	195.90	1530.334	44	193.85	1546.518
4	195.85	1530.725	45	193.80	1546.917
5	195.80	1531.116	46	193.75	1547.316
6	195.75	1531.507	47	193.70	1547.715
7	195.70	1531.898	48	193.65	1548.115

Table 6-7 DWDM Channel Allocation Plan (C Band) (continued)

Channel Number	Frequency (THz)	Wavelength (nm)	Channel Number	Frequency (THz)	Wavelength (nm)
8	195.65	1532.290	49	193.60	1548.515
9	195.60	1532.681	50	193.55	1548.915
10	195.55	1533.073	51	193.50	1549.32
11	195.50	1533.47	52	193.45	1549.71
12	195.45	1533.86	53	193.40	1550.116
13	195.40	1534.250	54	193.35	1550.517
14	195.35	1534.643	55	193.30	1550.918
15	195.30	1535.036	56	193.25	1551.319
16	195.25	1535.429	57	193.20	1551.721
17	195.20	1535.822	58	193.15	1552.122
18	195.15	1536.216	59	193.10	1552.524
19	195.10	1536.609	60	193.05	1552.926
20	195.05	1537.003	61	193.00	1553.33
21	195.00	1537.40	62	192.95	1553.73
22	194.95	1537.79	63	192.90	1554.134
23	194.90	1538.186	64	192.85	1554.537
24	194.85	1538.581	65	192.80	1554.940
25	194.80	1538.976	66	192.75	1555.343
26	194.75	1539.371	67	192.70	1555.747
27	194.70	1539.766	68	192.65	1556.151
28	194.65	1540.162	69	192.60	1556.555
29	194.60	1540.557	70	192.55	1556.959
30	194.55	1540.953	71	192.50	1557.36
31	194.50	1541.35	72	192.45	1557.77
32	194.45	1541.75	73	192.40	1558.173
33	194.40	1542.142	74	192.35	1558.578
34	194.35	1542.539	75	192.30	1558.983
35	194.30	1542.936	76	192.25	1559.389
36	194.25	1543.333	77	192.20	1559.794
37	194.20	1543.730	78	192.15	1560.200
38	194.15	1544.128	79	192.10	1560.606
39	194.10	1544.526	80	192.05	1561.013
40	194.05	1544.924	81	192.00	1561.42
41	194.00	1545.32	82	191.95	1561.83

Table 6-8 lists the channel IDs and wavelengths assigned to the L-band channels.

Table 6-8 DWDM Channel Allocation Plan (L Band)

Channel Number	Frequency (THz)	Wavelength (nm)	Channel Number	Frequency (THz)	Wavelength (nm)
1	190.85	1570.83	41	188.85	1587.46
2	190.8	1571.24	42	188.8	1587.88
3	190.75	1571.65	43	188.75	1588.30
4	190.7	1572.06	44	188.7	1588.73
5	190.65	1572.48	45	188.65	1589.15
6	190.6	1572.89	46	188.6	1589.57
7	190.55	1573.30	47	188.55	1589.99
8	190.5	1573.71	48	188.5	1590.41
9	190.45	1574.13	49	188.45	1590.83
10	190.4	1574.54	50	188.4	1591.26
11	190.35	1574.95	51	188.35	1591.68
12	190.3	1575.37	52	188.3	1592.10
13	190.25	1575.78	53	188.25	1592.52
14	190.2	1576.20	54	188.2	1592.95
15	190.15	1576.61	55	188.15	1593.37
16	190.1	1577.03	56	188.1	1593.79
17	190.05	1577.44	57	188.05	1594.22
18	190	1577.86	58	188	1594.64
19	189.95	1578.27	59	187.95	1595.06
20	189.9	1578.69	60	187.9	1595.49
21	189.85	1579.10	61	187.85	1595.91
22	189.8	1579.52	62	187.8	1596.34
23	189.75	1579.93	63	187.75	1596.76
24	189.7	1580.35	64	187.7	1597.19
25	189.65	1580.77	65	187.65	1597.62
26	189.6	1581.18	66	187.6	1598.04
27	189.55	1581.60	67	187.55	1598.47
28	189.5	1582.02	68	187.5	1598.89
29	189.45	1582.44	69	187.45	1599.32
30	189.4	1582.85	70	187.4	1599.75
31	189.35	1583.27	71	187.35	1600.17
32	189.3	1583.69	72	187.3	1600.60
33	189.25	1584.11	73	187.25	1601.03
34	189.2	1584.53	74	187.2	1601.46
35	189.15	1584.95	75	187.15	1601.88

Table 6-8 DWDM Channel Allocation Plan (L Band) (continued)

Channel Number	Frequency (THz)	Wavelength (nm)	Channel Number	Frequency (THz)	Wavelength (nm)
36	189.1	1585.36	76	187.1	1602.31
37	189.05	1585.78	77	187.05	1602.74
38	189	1586.20	78	187	1603.17
39	188.95	1586.62	79	186.95	1603.60
40	188.9	1587.04	80	186.9	1604.03

6.2 Safety Labels

For information about safety labels, see the “[G.1 Safety Labels](#)” section on page G-1”.

6.3 32MUX-O Card



Note

For 32MUX-O card specifications, see the “[32MUX-O Card Specifications](#)” section in the Hardware Specifications document.

The 32-Channel Multiplexer (32MUX-O) card multiplexes 32 100-GHz-spaced channels identified in the channel plan. The 32MUX-O card takes up two slots in an ONS 15454 and can be installed in Slots 1 to 5 and 12 to 16.

6.3.1 32MUX-O Card Functions

The 32MUX-O functions include:

- Arrayed waveguide grating (AWG) device that enables full multiplexing functions for the channels.
- Each single-channel port is equipped with VOAs for automatic optical power regulation prior to multiplexing. In the case of electrical power failure, the VOA is set to its maximum attenuation for safety purposes. A manual VOA setting is also available.
- Each single-channel port is monitored using a photodiode to enable automatic power regulation.
- Card level indicators—[Table G-4 on page G-9](#)

An additional optical monitoring port with 1:99 splitting ratio is available.

6.3.2 32MUX-O Card Faceplate and Block Diagram

[Figure 6-1](#) shows the 32MUX-O faceplate.

Figure 6-1 32MUX-O Faceplate

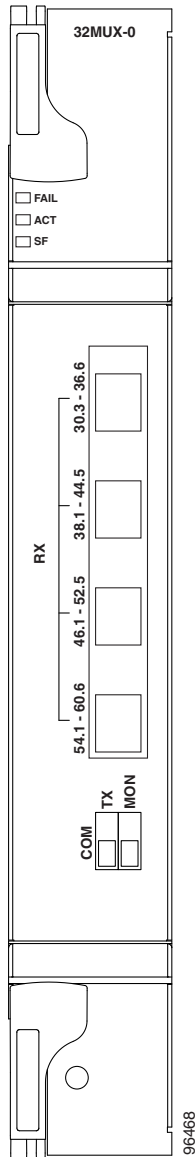

For information on safety labels for the card, see the “G.1 Safety Labels” section on page G-1”.

Figure 6-2 shows a block diagram of the 32MUX-O card.

Figure 6-2 32MUX-O Block Diagram

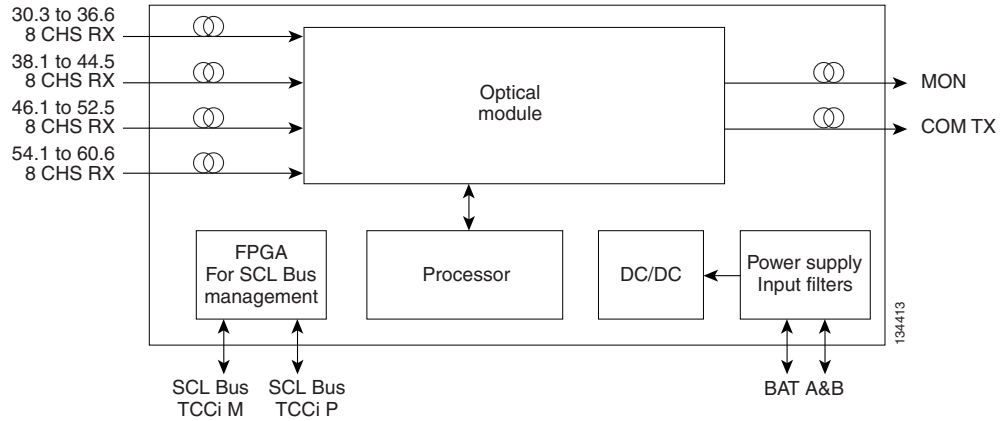

The 32MUX-O card has four receive connectors that accept multifiber push-on (MPO) cables on its front panel for the client input interfaces. MPO cables break out into eight separate cables. The 32MUX-O card also has two LC-PC-II optical connectors, one for the main output and the other for the monitor port.

Figure 6-3 shows the 32MUX-O optical module functional block diagram.

Figure 6-3 32MUX-O Optical Module Functional Block Diagram

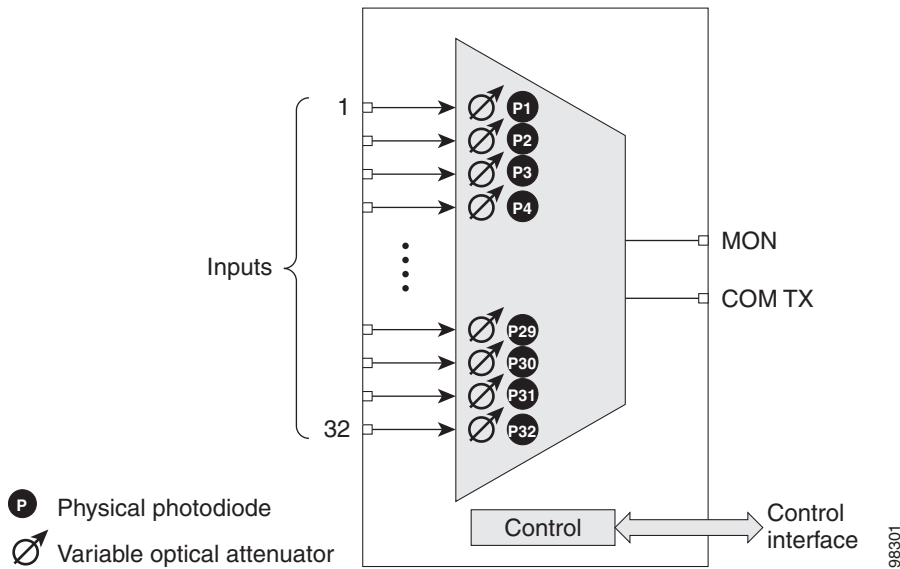

- P** Physical photodiode
- Variable optical attenuator

6.3.2.1 Port-Level Indicators for the 32MUX-O Cards

The 32MUX-O card has five sets of ports located on the faceplate. COM TX is the line output. COM MON is the optical monitoring port. The xx.x to yy.y RX ports represent the four groups of eight channels ranging from wavelength xx.x to wavelength yy.y, according to the channel plan.

6.3.3 Channel Plan

The 32MUX-O is typically used in hub nodes and provides the multiplexing of 32 channels, spaced at 100 GHz, into one fiber before their amplification and transmission along the line. The channel plan is shown in [Table 6-9](#).

Table 6-9 32MUX-O Channel Plan

Channel Number ¹	Channel ID	Frequency (GHz)	Wavelength (nm)
1	30.3	195.9	1530.33
2	31.2	195.8	1531.12
3	31.9	195.7	1531.90
4	32.6	195.6	1532.68
5	34.2	195.4	1534.25
6	35.0	195.3	1535.04
7	35.8	195.2	1535.82
8	36.6	195.1	1536.61
9	38.1	194.9	1538.19
10	38.9	194.8	1538.98
11	39.7	194.7	1539.77
12	40.5	194.6	1540.56
13	42.1	194.4	1542.14
14	42.9	194.3	1542.94
15	43.7	194.2	1543.73
16	44.5	194.1	1544.53
17	46.1	193.9	1546.12
18	46.9	193.8	1546.92
19	47.7	193.7	1547.72
20	48.5	193.6	1548.51
21	50.1	193.4	1550.12
22	50.9	193.3	1550.92
23	51.7	193.2	1551.72
24	52.5	193.1	1552.52
25	54.1	192.9	1554.13
26	54.9	192.8	1554.94
27	55.7	192.7	1555.75
28	56.5	192.6	1556.55
29	58.1	192.4	1558.17
30	58.9	192.3	1558.98

Table 6-9 32MUX-O Channel Plan

Channel Number ¹	Channel ID	Frequency (GHz)	Wavelength (nm)
31	59.7	192.2	1559.79
32	60.6	192.1	1560.61

1. The Channel Number column is only for reference purposes. The channel ID is consistent with the ONS 15454 and is used in card identification.

6.3.4 Power Monitoring

Physical photodiodes P1 through P32 monitor the power for the 32MUX-O card. The returned power level values are calibrated to the ports as shown in [Table 6-10](#).

Table 6-10 32MUX-O Port Calibration

Photodiode	CTC Type Name	Calibrated to Port
P1–P32	ADD	COM TX

For information on the associated TL1 AIDs for the optical power monitoring points, refer the “CTC Port Numbers and TL1 Aids” section in *Cisco ONS SONET TL1 Command Guide*.

6.3.5 Related Procedures for the 32MUX-O Card

The following is the list of procedures and tasks related to the configuration of the 32MUX-O card:

- “DLP-G353 Preprovision a Slot” task on page 14-53
- “NTP-G30 Install the DWDM Cards” task on page 14-63
- “NTP-G143 Import the Cisco Transport Planner NE Update Configuration File” task on page 14-47
- “NTP-G34 Install Fiber-Optic Cables on DWDM Cards and DCUs” task on page 14-74
- “NTP-G140 Install Fiber-Optic Cables Between Terminal, Hub, or ROADM Nodes” task on page 14-79
- “DLP-G315 Install Fiber-Optic Cables From the 32WSS/32DMX and 32MUX-O/32DMX-O Cards to the Standard Patch Panel Tray” task on page 14-82
- “DLP-G356 Install Fiber-Optic Cables from the 32WSS/32DMX and 32MUX-O/32DMX-O Cards to the Deep Patch Panel Tray” task on page 14-87
- “NTP-G184 Create a Provisionable Patchcord” task on page 17-77
- “NTP-G152 Create and Verify Internal Patchcords” task on page 14-110
- “NTP-G242 Create an Internal Patchcord Manually” task on page 14-111
- “NTP-G86 Convert a Pass-Through Connection to Add/Drop Connections”
- “NTP-G41 Perform the Terminal or Hub Node with 32MUX-O and 32DMX-O Cards Acceptance Test” task on page 15-3
- “NTP-G44 Perform the Anti-ASE Hub Node Acceptance Test” task on page 15-72
- “NTP-G74 Monitor DWDM Card Performance”

- “DLP-G141 View Optical Power Statistics for 32MUX-O, 32WSS, 32WSS-L, 32DMX-O, 32DMX, 32DMX-L, 40-WSS-C, 40-WSS-CE, 40-WXC-C, 80-WXC-C, 40-MUX-C, 40-DMX-C, and 40-DMX-CE Cards”
- “NTP-G175 Modify 32MUX-O, 32DMX-O, 32DMX, 32DMX-L, 40-MUX-C, 40-DMX-C, 40-DMX-CE, and 4MD-xx.x Line Card Settings and PM Thresholds” task on page 21-54
- “DLP-G414 Change Optical Line Settings for 32MUX-O, 32DMX-O, 32DMX, 32DMX-L, 40-MUX-C, 40-DMX-C, 40-DMX-CE, or 4MD-xx.x Cards” task on page 21-55
- “DLP-G415 Change Optical Line Threshold Settings for 32MUX-O, 32DMX-O, 32DMX, 32DMX-L, 40-MUX-C, 40-DMX-C, 40-DMX-CE, or 4MD-xx.x Cards” task on page 21-57
- “DLP-G416 Change Optical Channel Settings for 32MUX-O, 32DMX-O, 32DMX, 32DMX-L, 40-MUX-C, 40-DMX-C, 40-DMX-CE, or 4MD-xx.x Cards” task on page 21-59
- “DLP-G417 Change Optical Channel Threshold Settings for 32MUX-O, 32DMX-O, 32DMX, 32DMX-L, 40-MUX-C, 40-DMX-C, 40-DMX-CE, or 4MD-xx.x Cards” task on page 21-62
- “DLP-G78 Verify the 32MUX-O or 40-MUX-C Card Power” task on page 15-7
- “DLP-G269 Verify the 32DMX-O or 40-DMX-C Card Power” task on page 15-7
- “DLP-G355 Delete an Internal Patchcord” task on page 14-120
- “NTP-G106 Reset Cards Using CTC” task on page 24-14
- “DLP-G251 Reset DWDM Cards Using CTC” task on page 24-15
- “NTP-G107 Remove Permanently or Remove and Replace DWDM Card”
- “DLP-G351 Delete a Card in CTC” task on page 14-51
- “NTP-G119 Power Down the Node” task on page 24-23

6.4 32DMX-O Card



Note

For 32DMX-O card specifications, see the “[32DMX-O Card Specifications](#)” section in the Hardware Specifications document.

The 32-Channel Demultiplexer (32DMX-O) card demultiplexes 32 100-GHz-spaced channels identified in the channel plan. The 32DMX-O takes up two slots in an ONS 15454 and can be installed in Slots 1 to 5 and 12 to 16.

6.4.1 32DMX-O Card Functions

The 32DMX-O functions include:

- AWG that enables channel demultiplexing functions.
- Each single-channel port is equipped with VOAs for automatic optical power regulation after demultiplexing. In the case of electrical power failure, the VOA is set to its maximum attenuation for safety purposes. A manual VOA setting is also available.
- The 32DXM-O has four physical receive connectors that accept MPO cables on its front panel for the client input interfaces. MPO cables break out into eight separate cables.

**Note**

In contrast, the single-slot 32DMX card does not have VOAs on each drop port for optical power regulation. The 32DMX optical demultiplexer module is used in conjunction with the 32WSS card in ONS 15454 Multiservice Transport Platform (MSTP) nodes.

- Each single-channel port is monitored using a photodiode to enable automatic power regulation.
- Card level indicators—[Table G-4 on page G-9](#)

6.4.2 32DMX-O Card Faceplate and Block Diagram

[Figure 6-4](#) shows the 32DMX-O card faceplate.

Figure 6-4 32DMX-O Faceplate

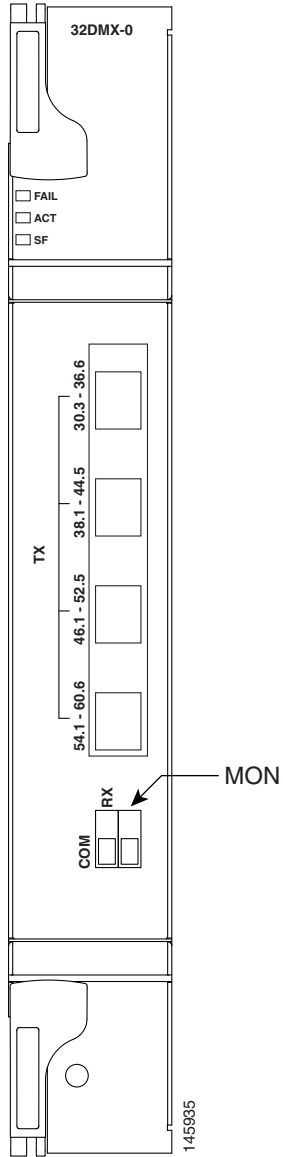

For information on safety labels for the card, see the “G.1 Safety Labels” section on page G-1”.

Figure 6-5 shows a block diagram of the 32DMX-O card.

Figure 6-5 32DMX-O Block Diagram

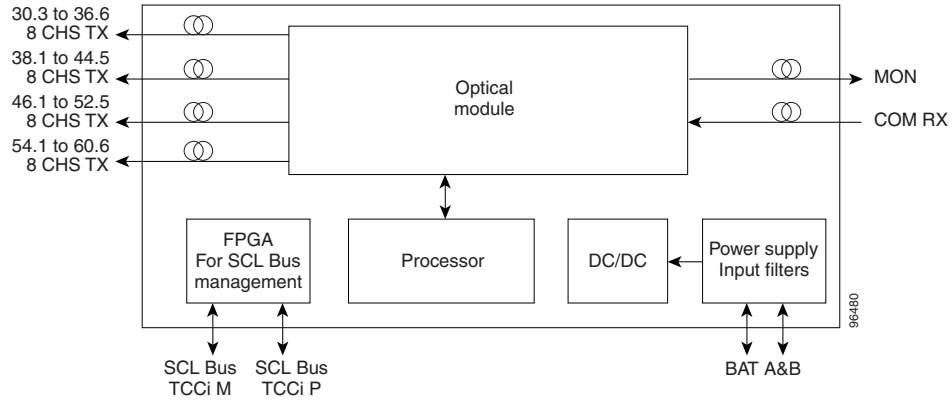
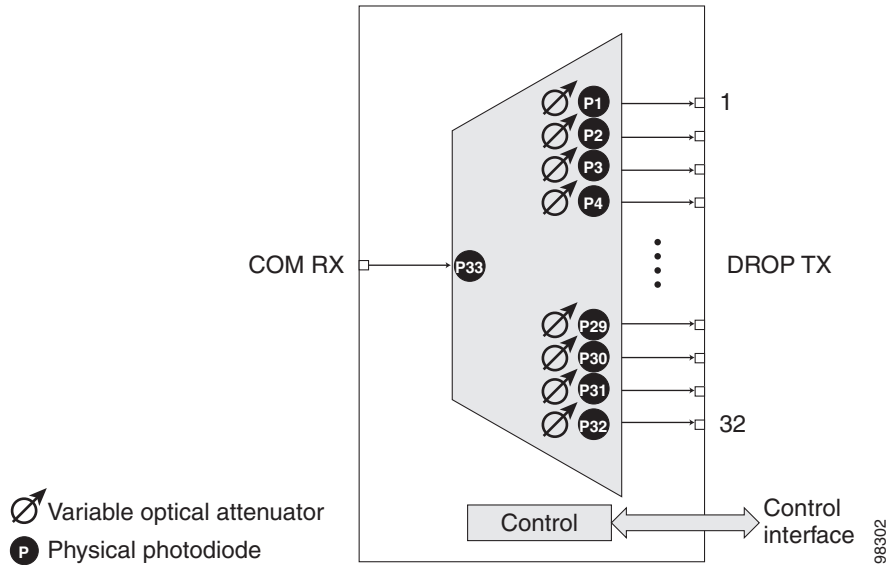



Figure 6-6 shows the 32DMX-O optical module functional block diagram.

Figure 6-6 32DMX-O Optical Module Functional Block Diagram



 Variable optical attenuator
 Physical photodiode

6.4.2.1 Port-Level Indicators for the 32DMX-O Cards

The 32DMX-O card has five sets of ports located on the faceplate. MON is the output monitor port. COM RX is the line input. The xx.x to yy.y TX ports represent the four groups of eight channels ranging from wavelength xx.x to wavelength yy.y according to the channel plan.

6.4.3 Power Monitoring

Physical photodiodes P1 through P33 monitor the power for the 32DMX-O card. The returned power level values are calibrated to the ports as shown in Table 6-11.

Table 6-11 32DMX-O Port Calibration

Photodiode	CTC Type Name	Calibrated to Port
P1–P32	DROP	DROP TX
P33	INPUT COM	COM RX

For information on the associated TL1 AIDs for the optical power monitoring points, refer the “CTC Port Numbers and TL1 Aids” section in *Cisco ONS SONET TL1 Command Guide, Release 9.2.1*.

6.4.4 Related Procedures for the 32DMX-O Card

The following is the list of procedures and tasks related to the configuration of the 32DMX-O card:

- “DLP-G353 Preprovision a Slot” task on page 14-53
- “NTP-G30 Install the DWDM Cards” task on page 14-63
- “NTP-G143 Import the Cisco Transport Planner NE Update Configuration File” task on page 14-47
- “NTP-G34 Install Fiber-Optic Cables on DWDM Cards and DCUs” task on page 14-74
- “NTP-G140 Install Fiber-Optic Cables Between Terminal, Hub, or ROADM Nodes” task on page 14-79
- “DLP-G315 Install Fiber-Optic Cables From the 32WSS/32DMX and 32MUX-O/32DMX-O Cards to the Standard Patch Panel Tray” task on page 14-82
- “DLP-G356 Install Fiber-Optic Cables from the 32WSS/32DMX and 32MUX-O/32DMX-O Cards to the Deep Patch Panel Tray” task on page 14-87
- “NTP-G184 Create a Provisionable Patchcord” task on page 17-77
- “NTP-G152 Create and Verify Internal Patchcords” task on page 14-110
- “NTP-G242 Create an Internal Patchcord Manually” task on page 14-111
- “NTP-G86 Convert a Pass-Through Connection to Add/Drop Connections”
- “NTP-G44 Perform the Anti-ASE Hub Node Acceptance Test” task on page 15-72
- “NTP-G41 Perform the Terminal or Hub Node with 32MUX-O and 32DMX-O Cards Acceptance Test” task on page 15-3
- “NTP-G74 Monitor DWDM Card Performance”
- “DLP-G78 Verify the 32MUX-O or 40-MUX-C Card Power” task on page 15-7
- “DLP-G269 Verify the 32DMX-O or 40-DMX-C Card Power” task on page 15-7
- “DLP-G141 View Optical Power Statistics for 32MUX-O, 32WSS, 32WSS-L, 32DMX-O, 32DMX, 32DMX-L, 40-WSS-C, 40-WSS-CE, 40-WXC-C, 80-WXC-C, 40-MUX-C, 40-DMX-C, and 40-DMX-CE Cards”
- “NTP-G175 Modify 32MUX-O, 32DMX-O, 32DMX, 32DMX-L, 40-MUX-C, 40-DMX-C, 40-DMX-CE, and 4MD-xx.x Line Card Settings and PM Thresholds” task on page 21-54
- “DLP-G414 Change Optical Line Settings for 32MUX-O, 32DMX-O, 32DMX, 32DMX-L, 40-MUX-C, 40-DMX-C, 40-DMX-CE, or 4MD-xx.x Cards” task on page 21-55
- “DLP-G415 Change Optical Line Threshold Settings for 32MUX-O, 32DMX-O, 32DMX, 32DMX-L, 40-MUX-C, 40-DMX-C, 40-DMX-CE, or 4MD-xx.x Cards” task on page 21-57

- “DLP-G416 Change Optical Channel Settings for 32MUX-O, 32DMX-O, 32DMX, 32DMX-L, 40-MUX-C, 40-DMX-C, 40-DMX-CE, or 4MD-xx.x Cards” task on page 21-59
- “DLP-G417 Change Optical Channel Threshold Settings for 32MUX-O, 32DMX-O, 32DMX, 32DMX-L, 40-MUX-C, 40-DMX-C, 40-DMX-CE, or 4MD-xx.x Cards” task on page 21-62
- “DLP-G355 Delete an Internal Patchcord” task on page 14-120
- “NTP-G106 Reset Cards Using CTC” task on page 24-14
- “DLP-G251 Reset DWDM Cards Using CTC” task on page 24-15
- “NTP-G107 Remove Permanently or Remove and Replace DWDM Card”
- “DLP-G351 Delete a Card in CTC” task on page 14-51
- “NTP-G119 Power Down the Node” task on page 24-23

6.5 4MD-xx.x Card



Note

For 4MD-xx.x card specifications, see the section “[4MD-xx.x Card Specifications](#)” section in the Hardware Specifications document.

The 4-Channel Multiplexer/Demultiplexer (4MD-xx.x) card multiplexes and demultiplexes four 100-GHz-spaced channels identified in the channel plan. The 4MD-xx.x card is designed to be used with band OADMs (both AD-1B-xx.x and AD-4B-xx.x).

The card is bidirectional. The demultiplexer and multiplexer functions are implemented in two different sections of the same card. In this way, the same card can manage signals flowing in opposite directions.

There are eight versions of this card that correspond with the eight sub-bands specified in [Table 6-12 on page 6-22](#). The 4MD-xx.x can be installed in Slots 1 to 6 and 12 to 17.

6.5.1 4MD-xx.x Card Functions

The 4MD-xx.x has the following functions implemented inside a plug-in optical module:

- Passive cascade of interferential filters perform the channel multiplex/demultiplex function.
- Software-controlled VOAs at every port of the multiplex section regulate the optical power of each multiplexed channel.
- Software-monitored photodiodes at the input and output multiplexer and demultiplexer ports for power control and safety purposes.
- Software-monitored virtual photodiodes at the common DWDM output and input ports. A virtual photodiode is a firmware calculation of the optical power at that port. This calculation is based on the single channel photodiode reading and insertion losses of the appropriated paths.
- Card level indicators—[Table G-4 on page G-9](#)

6.5.2 4MD-xx.x Card Faceplate and Block Diagram

[Figure 6-7](#) shows the 4MD-xx.x faceplate.

Figure 6-7 4MD-xx.x Faceplate

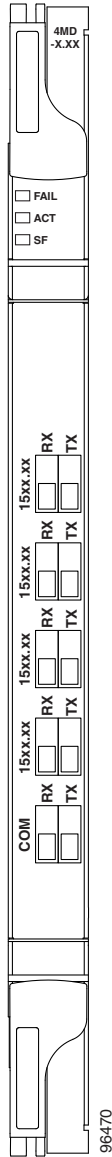

For information on safety labels for the card, see the “[G.1 Safety Labels](#)” section on page G-1”.

[Figure 6-8](#) shows a block diagram of the 4MD-xx.x card.

Figure 6-8 4MD-xx.x Block Diagram

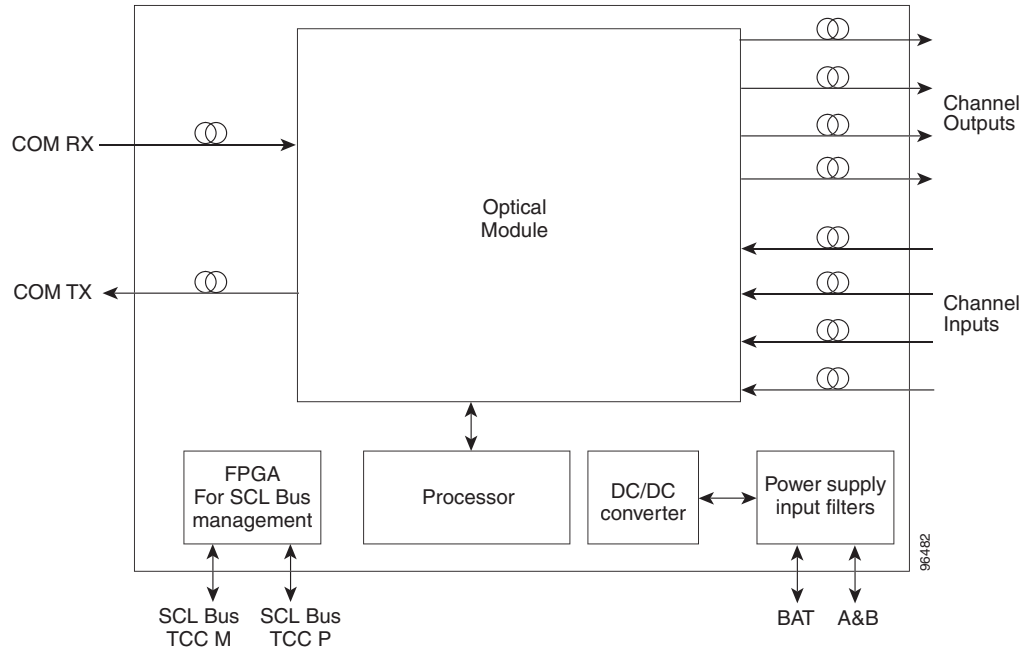
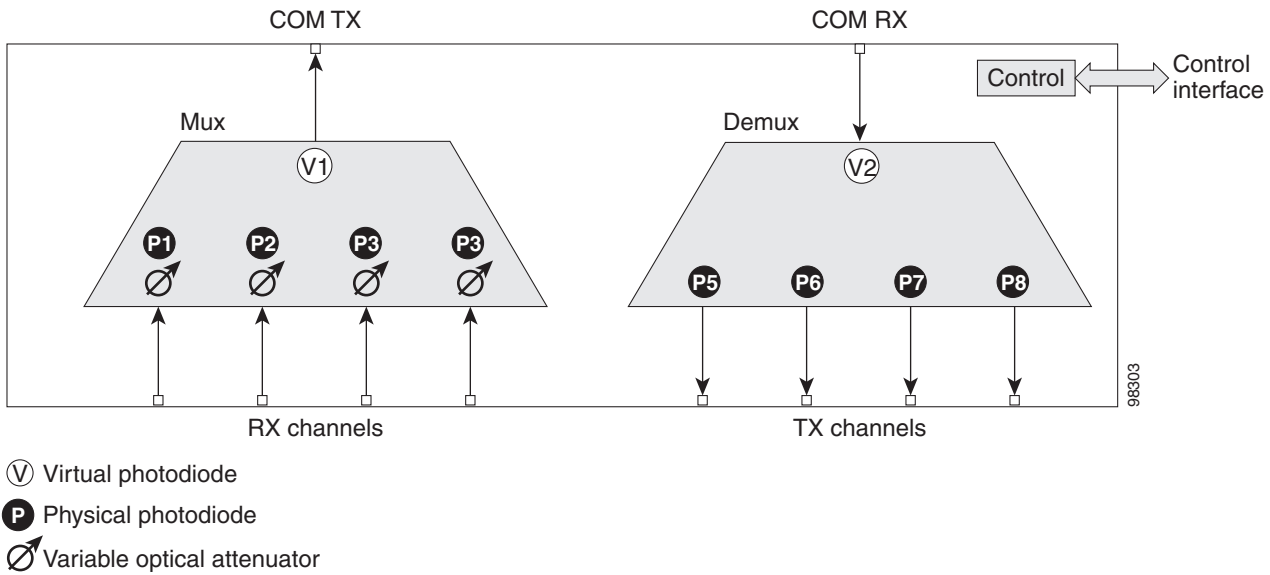

Figure 6-9 shows the 4MD-xx.x optical module functional block diagram.

Figure 6-9 4MD-xx.x Optical Module Functional Block Diagram



The optical module shown in Figure 6-9 is optically passive and consists of a cascade of interferential filters that perform the channel multiplexing and demultiplexing functions.

VOAs are present in every input path of the multiplex section in order to regulate the optical power of each multiplexed channel. Some optical input and output ports are monitored by means of photodiodes implemented both for power control and for safety purposes. An internal control manages VOA settings and functionality as well as photodiode detection and alarm thresholds. The power at the main output

and input ports is monitored through the use of virtual photodiodes. A virtual photodiode is implemented in the firmware of the plug-in module. This firmware calculates the power on a port, summing the measured values from all single channel ports (and applying the proper path insertion loss) and then providing the TCC2/TCC2P/TCC3/TNC/TNCE/TSC/TSCE card with the obtained value.

6.5.2.1 Port-Level Indicators for the 4MD-xx.x Cards

The 4MD-xx.x card has five sets of ports located on the faceplate. COM RX is the line input. COM TX is the line output. The 15xx.x TX ports represent demultiplexed channel outputs 1 to 4. The 15xx.x RX ports represent multiplexed channel inputs 1 to 4.

6.5.3 Wavelength Pairs

Table 6-12 shows the band IDs and the add/drop channel IDs for the 4MD-xx.x card.

Table 6-12 4MD-xx.x Channel Sets

Band ID	Add/Drop Channel IDs
Band 30.3 (A)	30.3, 31.2, 31.9, 32.6
Band 34.2 (B)	34.2, 35.0, 35.8, 36.6
Band 38.1 (C)	38.1, 38.9, 39.7, 40.5
Band 42.1 (D)	42.1, 42.9, 43.7, 44.5
Band 46.1 (E)	46.1, 46.9, 47.7, 48.5
Band 50.1 (F)	50.1, 50.9, 51.7, 52.5
Band 54.1 (G)	54.1, 54.9, 55.7, 56.5
Band 58.1 (H)	58.1, 58.9, 59.7, 60.6

6.5.4 Power Monitoring

Physical photodiodes P1 through P8 and virtual photodiodes V1 and V2 monitor the power for the 4MD-xx.x card. The returned power level values are calibrated to the ports as shown in Table 6-13.

Table 6-13 4MD-xx.x Port Calibration

Photodiode	CTC Type Name	Calibrated to Port
P1–P4	ADD	COM TX
P5–P8	DROP	DROP TX
V1	OUT COM	COM TX
V2	IN COM	COM RX

For information on the associated TL1 AIDs for the optical power monitoring points, refer the “CTC Port Numbers and TL1 Aids” section in *Cisco ONS SONET TL1 Command Guide, Release 9.2.1*.

6.5.5 Related Procedures for the 4MD-xx.x Card

The following is the list of procedures and tasks related to the configuration of the 4MD-xx.x card:

- “DLP-G353 Preprovision a Slot” task on page 14-53
- “NTP-G30 Install the DWDM Cards” task on page 14-63
- “NTP-G143 Import the Cisco Transport Planner NE Update Configuration File” task on page 14-47
- “NTP-G48 Perform the OADM Node Acceptance Test on a Symmetric Node with OSCM Cards” task on page 15-95
- “DLP-G89 Verify OADM Node Pass-Through Channel Connections” task on page 15-100
- “DLP-G92 Verify 4MD-xx.x Pass-Through Connection Power” task on page 15-101
- “DLP-G93 Verify Add and Drop Connections on an OADM Node with OSCM Cards” task on page 15-105
- “NTP-G49 Perform the Active OADM Node Acceptance Test on a Symmetric Node with OSC-CSM Cards” task on page 15-107
- “DLP-G94 Verify Add and Drop Connections on an OADM Node with OSC-CSM Cards” task on page 15-111
- “NTP-G59 Create, Delete, and Manage Optical Channel Network Connections” task on page 17-40
- “DLP-G105 Provision Optical Channel Network Connections” task on page 17-44
- “NTP-G34 Install Fiber-Optic Cables on DWDM Cards and DCUs” task on page 14-74
- “NTP-G140 Install Fiber-Optic Cables Between Terminal, Hub, or ROADM Nodes” task on page 14-79
- “DLP-G315 Install Fiber-Optic Cables From the 32WSS/32DMX and 32MUX-O/32DMX-O Cards to the Standard Patch Panel Tray” task on page 14-82
- “DLP-G356 Install Fiber-Optic Cables from the 32WSS/32DMX and 32MUX-O/32DMX-O Cards to the Deep Patch Panel Tray” task on page 14-87
- “NTP-G184 Create a Provisionable Patchcord” task on page 17-77
- “NTP-G152 Create and Verify Internal Patchcords” task on page 14-110
- “NTP-G242 Create an Internal Patchcord Manually” task on page 14-111
- “NTP-G41 Perform the Terminal or Hub Node with 32MUX-O and 32DMX-O Cards Acceptance Test” task on page 15-3
- “NTP-G44 Perform the Anti-ASE Hub Node Acceptance Test” task on page 15-72
- “NTP-G86 Convert a Pass-Through Connection to Add/Drop Connections”
- “NTP-G74 Monitor DWDM Card Performance”
- “DLP-G78 Verify the 32MUX-O or 40-MUX-C Card Power” task on page 15-7
- “DLP-G269 Verify the 32DMX-O or 40-DMX-C Card Power” task on page 15-7
- “DLP-G141 View Optical Power Statistics for 32MUX-O, 32WSS, 32WSS-L, 32DMX-O, 32DMX, 32DMX-L, 40-WSS-C, 40-WSS-CE, 40-WXC-C, 80-WXC-C, 40-MUX-C, 40-DMX-C, and 40-DMX-CE Cards”
- “NTP-G175 Modify 32MUX-O, 32DMX-O, 32DMX, 32DMX-L, 40-MUX-C, 40-DMX-C, 40-DMX-CE, and 4MD-xx.x Line Card Settings and PM Thresholds” task on page 21-54

- “DLP-G414 Change Optical Line Settings for 32MUX-O, 32DMX-O, 32DMX, 32DMX-L, 40-MUX-C, 40-DMX-C, 40-DMX-CE, or 4MD-xx.x Cards” task on page 21-55
- “DLP-G415 Change Optical Line Threshold Settings for 32MUX-O, 32DMX-O, 32DMX, 32DMX-L, 40-MUX-C, 40-DMX-C, 40-DMX-CE, or 4MD-xx.x Cards” task on page 21-57
- “DLP-G416 Change Optical Channel Settings for 32MUX-O, 32DMX-O, 32DMX, 32DMX-L, 40-MUX-C, 40-DMX-C, 40-DMX-CE, or 4MD-xx.x Cards” task on page 21-59
- “DLP-G417 Change Optical Channel Threshold Settings for 32MUX-O, 32DMX-O, 32DMX, 32DMX-L, 40-MUX-C, 40-DMX-C, 40-DMX-CE, or 4MD-xx.x Cards” task on page 21-62
- “DLP-G355 Delete an Internal Patchcord” task on page 14-120
- “NTP-G106 Reset Cards Using CTC” task on page 24-14
- “DLP-G251 Reset DWDM Cards Using CTC” task on page 24-15
- “NTP-G107 Remove Permanently or Remove and Replace DWDM Card”
- “DLP-G351 Delete a Card in CTC” task on page 14-51
- “NTP-G119 Power Down the Node” task on page 24-23