



Cisco NCS 1010 System Setup and Software Installation Guide, IOS XR Release 7.7.x

First Published: 2022-07-29

Last Modified: 2023-09-08

Americas Headquarters

Cisco Systems, Inc.
170 West Tasman Drive
San Jose, CA 95134-1706
USA
<http://www.cisco.com>
Tel: 408 526-4000
800 553-NETS (6387)
Fax: 408 527-0883

THE SPECIFICATIONS AND INFORMATION REGARDING THE PRODUCTS IN THIS MANUAL ARE SUBJECT TO CHANGE WITHOUT NOTICE. ALL STATEMENTS, INFORMATION, AND RECOMMENDATIONS IN THIS MANUAL ARE BELIEVED TO BE ACCURATE BUT ARE PRESENTED WITHOUT WARRANTY OF ANY KIND, EXPRESS OR IMPLIED. USERS MUST TAKE FULL RESPONSIBILITY FOR THEIR APPLICATION OF ANY PRODUCTS.

THE SOFTWARE LICENSE AND LIMITED WARRANTY FOR THE ACCOMPANYING PRODUCT ARE SET FORTH IN THE INFORMATION PACKET THAT SHIPPED WITH THE PRODUCT AND ARE INCORPORATED HEREIN BY THIS REFERENCE. IF YOU ARE UNABLE TO LOCATE THE SOFTWARE LICENSE OR LIMITED WARRANTY, CONTACT YOUR CISCO REPRESENTATIVE FOR A COPY.

The Cisco implementation of TCP header compression is an adaptation of a program developed by the University of California, Berkeley (UCB) as part of UCB's public domain version of the UNIX operating system. All rights reserved. Copyright © 1981, Regents of the University of California.

NOTWITHSTANDING ANY OTHER WARRANTY HEREIN, ALL DOCUMENT FILES AND SOFTWARE OF THESE SUPPLIERS ARE PROVIDED "AS IS" WITH ALL FAULTS. CISCO AND THE ABOVE-NAMED SUPPLIERS DISCLAIM ALL WARRANTIES, EXPRESSED OR IMPLIED, INCLUDING, WITHOUT LIMITATION, THOSE OF MERCHANTABILITY, FITNESS FOR A PARTICULAR PURPOSE AND NON-INFRINGEMENT OR ARISING FROM A COURSE OF DEALING, USAGE, OR TRADE PRACTICE.

IN NO EVENT SHALL CISCO OR ITS SUPPLIERS BE LIABLE FOR ANY INDIRECT, SPECIAL, CONSEQUENTIAL, OR INCIDENTAL DAMAGES, INCLUDING, WITHOUT LIMITATION, LOST PROFITS OR LOSS OR DAMAGE TO DATA ARISING OUT OF THE USE OR INABILITY TO USE THIS MANUAL, EVEN IF CISCO OR ITS SUPPLIERS HAVE BEEN ADVISED OF THE POSSIBILITY OF SUCH DAMAGES.

Any Internet Protocol (IP) addresses and phone numbers used in this document are not intended to be actual addresses and phone numbers. Any examples, command display output, network topology diagrams, and other figures included in the document are shown for illustrative purposes only. Any use of actual IP addresses or phone numbers in illustrative content is unintentional and coincidental.

All printed copies and duplicate soft copies of this document are considered uncontrolled. See the current online version for the latest version.

Cisco has more than 200 offices worldwide. Addresses and phone numbers are listed on the Cisco website at www.cisco.com/go/offices.

Cisco and the Cisco logo are trademarks or registered trademarks of Cisco and/or its affiliates in the U.S. and other countries. To view a list of Cisco trademarks, go to this URL: <https://www.cisco.com/c/en/us/about/legal/trademarks.html>. Third-party trademarks mentioned are the property of their respective owners. The use of the word partner does not imply a partnership relationship between Cisco and any other company. (1721R)

© 2023 Cisco Systems, Inc. All rights reserved.



CONTENTS

Full Cisco Trademarks with Software License ?

CHAPTER 1

Cisco NCS 1010 Optical Line System - An Overview 1

NCS 1010 Chassis and Line Cards 1

Line Cards 2

OLT-C Line Card 2

OLT-R-C Line Card 2

ILA-C Line Card 3

ILA-R-C Line Card 3

ILA-2R-C Line Card 3

External Interface Timing Unit 3

Cisco NCS 1000 Passive Modules 4

Cisco NCS 1000 Breakout Patch Panel 4

NCS1K-BRK-8 4

NCS1K-BRK-24 5

Cisco NCS 1000 32-Channel Mux/Demux Patch Panels 5

Document Objective 6

Document Organization 6

CHAPTER 2

Bring-up Cisco NCS 1010 9

Boot NCS 1010 9

Boot NCS 1010 Using USB Drive 10

DHCP Configuration 11

Introduction to DHCP Relay 11

Prerequisites for Configuring DHCP Relay Agent 12

Limitations for DHCP Relay Feature 12

- Configuring and Enabling the DHCP Relay Agent 13
- DHCP Client 13
- Boot Using iPXE 14
 - Setup DHCP Server 14
 - Boot Using iPXE 15
- Boot Using Zero Touch Provisioning 19
 - Fresh Boot Using DHCP 20
 - Build your Configuration File 21
 - Configure ZTP BootScript 22
 - Invoke ZTP Manually through CLI 24
 - Invoke ZTP Through Reload 25
 - ZTP Logging 26
 - Generate Tech Support Information for ZTP 27
- Configure Management Interface 28
 - Link Layer Discovery Protocol Support on Management Interface 29
- Configure Telnet 33
- Configure SSH 33

CHAPTER 3

- Disaster Recovery 35**
 - Overview 35
 - CPU Replacement Considerations 35
 - Health Check of Backup ISO Image 35

CHAPTER 4

- Perform Preliminary Checks 37**
 - Verify Status of Hardware Components 37
 - Verify Inventory 38
 - Verify Software Version 39
 - Verify Firmware Version 40
 - Verify Management Interface Status 42
 - Verify Alarms 43
 - Verify Environmental Parameters 44
 - Verify Context 49
 - Verify Core Files 50
 - Verify Memory Information 50

CHAPTER 5	Upgrade Software and FPD	51
	Upgrade Software	51
	Software Upgrade and Downgrade Matrix	53
	Install Packages and RPMs	53
	NCS 1010 FPD	57
	Verify if an FPD Upgrade is Required	61
	Upgrade FPDs Manually	63
	Upgrade FPDs Automatically	64

CHAPTER 6	Remote Node Management in NCS 1010	65
	Understanding Remote Node Management Using OSC	65
	Prerequisites	65
	DHCP Relay Configuration for OLT Node	66
	Loopback IP address for OSC Interface	67
	OSPF Neighbor Discovery	67
	Configure ILA Node	68
	Configure OLT Node	68



CHAPTER 1

Cisco NCS 1010 Optical Line System - An Overview

This chapter provides an overview for NCS 1010 line system.

- [NCS 1010 Chassis and Line Cards](#), on page 1
- [Cisco NCS 1000 Passive Modules](#), on page 4
- [Document Objective](#), on page 6
- [Document Organization](#), on page 6

NCS 1010 Chassis and Line Cards

Cisco NCS 1010 is a next-generation optical line system optimized for ZR/ZR+ WDM router interfaces. Its salient features are:

- Provides point-to-point connectivity between routers with WDM interfaces.
- Multiplexes the signals received from multiple routers over a single fiber.
- With one MPO port, it can be scaled to 8 Degree.
- Caters to C-band WDM transmission to maximize capacity, and can be enhanced to C+L combined band in the future.

Cisco NCS 1010 is a 3RU chassis that has an in-built External Interface Timing Unit (EITU) and the following field-replaceable modules.

- Controller
- Two power supply units
- Two fan trays
- Fan filter
- Line card

See [Hardware Installation Guide for Cisco NCS 1010 and Cisco NCS 1000 Passive Modules](#) for more detailed images.

Line Cards

There are five different variants of the line card:

- OLT-C Line Card: C-band Optical Line Terminal without Raman
- OLT-R-C Line Card: C-band Optical Line Terminal with Raman
- ILA-C Line Card: C-band In-Line Amplifier without Raman
- ILA-R-C Line Card: C-band In-Line Amplifier with one side Raman
- ILA-2R-C Line Card: C-band In-Line Amplifier with both sides Raman

OLT-C Line Card

The C-band Optical Line Terminal without Raman (OLT-C) line card includes the following features:

- 25-dBm line preamplifier True Variable Gain (TVG) Erbium-Doped Fiber Amplifier (EDFA) with two switchable gain ranges
- Dedicated amplification of the odd and even add channels through an embedded Fixed Gain (FG) EDFA
- 23-dBm line boost-amplifier TVG EDFA single gain range
- Dedicated EDFA for noise loading
- Embedded Optical Time Domain Reflectometer (OTDR) for line RX and TX monitoring
- 37 ports Optical Channel Monitoring (OCM)
- Dedicated Tunable Laser (TL) enabling Connection Verification (CV) and patch cord discovery features
- Up to 30 EXP ports
- Embedded Optical Service Channel at Fast Ethernet (FE)
- Multiplexing and demultiplexing of odd and even channels
- C+L combiner for multiplexing and demultiplexing L-band channels
- 2x2 switch to reverse transmit direction of Optical Service Channel (OSC)-C
- Fiber reflectors to support fiber end detection by OTDR

OLT-R-C Line Card

The C-band Optical Line Terminal with Raman (OLT-R-C) line card includes the features of the OLT-C line card along with the Raman amplifier.

The following are the features of the Raman amplifier:

- Five different pump wavelengths for supporting C+L Raman amplification
- Embedded Distributed Feedback (DFB) laser at 1568.77 nm (class 1M) to be used for optical safety (link continuity)
- Full monitoring of pumps, DFB laser and signal power
- Raman pump back-reflection detector

- Meets class 1M Laser safety.
- Additional Photodiode (PD) to monitor remnant pump power at the far end

ILA-C Line Card

The C-band In Line Amplifier without Raman (ILA-C) line card includes the following features:

- Two independent TVG EDFA block, covering full operative gain ranging 8–36 dB
- Each EDFA block can provide up to 23 dBm output power
- Dynamic Gain Equalization (DGE) embedded capability to compensate for line tilt and ripple
- Embedded OTDR for line1/2-RX/TX monitoring
- Four-ports OCM for channels monitoring
- Embedded Optical Service Channel at Fast Ethernet (FE)
- C+L combiner for multiplexing/demultiplexing L-band channels
- Dedicated ports for amplifiers output monitoring
- 2x2 switch to reverse transmit direction of OSC-C for both directions
- Fiber reflectors to support fiber end detection by OTDR

The following image displays the port connection between the ILA-C line card and OLT-C line cards.

Figure 1: ILA-C Line Card Port Connection

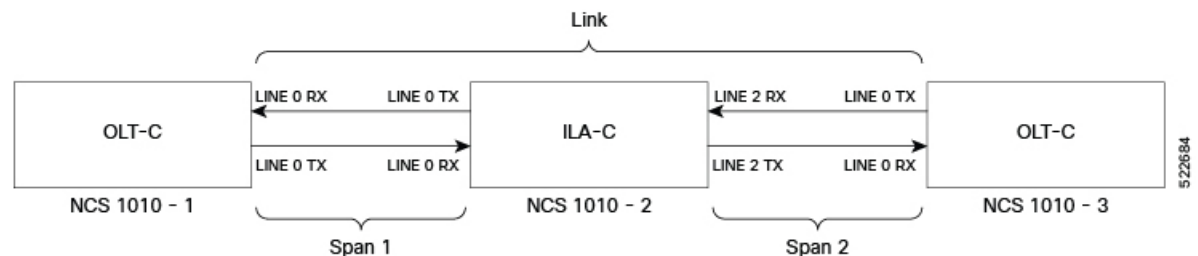

ILA-R-C Line Card

The C-band In Line Amplifier with Raman (ILA-R-C) line card includes the features of ILA-C and Raman amplifier.

ILA-2R-C Line Card

The C-band In-Line Amplifier with two Raman (ILA-2R-C) line card includes the features of the ILA-C and Raman amplifier on both directions.

External Interface Timing Unit

The External Interface Timing Unit (EITU) manages the control plane interfaces and includes all user external interfaces (timing and management). It is connected to the controller with a redundant 10G Ethernet bus.

The following is the list of the available user interfaces:

- Coaxial connector for GPS antenna RF input (with +5V antenna power, if necessary)
- Console/Universal Asynchronous Receiver/Transmitter (UART) Interface (1x)
- Two Small Form-Factor Pluggables (SFP) for 1GE optical PTP port (1588 and SyncE)
- Two SFPs for 1GE optical User Data Channels (UDC)
- Three USB 2.0 type A, 1.8A max @5V/12V (with Cisco NCS 1000 Breakout Patch Panel support)
- Coaxial connector for 10MHz sync signal (bidirectional)
- Coaxial connector for 1PPS sync signal (bidirectional)
- RJ45 for 1588 TOD (1x)
- Three 10/100/1000 RJ-45 Ethernet management ports and Interconnection Link (ILINK)

Cisco NCS 1000 Passive Modules

The Cisco NCS 1000 passive modules power the Cisco NCS 1010 chassis to offer an optical line system solution. The passive modules enable the NCS 1010 chassis to implement long-haul and metro topologies. The Cisco NCS 1010 supports the following passive modules:

Cisco NCS 1000 Breakout Patch Panel

Cisco NCS 1000 Breakout Patch Panel is colorless breakout-modular patch panel. It is powered by the NCS 1010 chassis using a single USB 2.0 cable from the NCS 1010 EITU. The breakout panel contains four USB 2.0 connections that power the breakout modules. It allows connections between the OLT-C and OLT-R-C line cards that are installed in the NCS 1010 chassis and the four breakout modules using MPO cables. The breakout panel supports up to 72 colorless Mux/Demux channels and 8-directional interconnections. The breakout panel is 4 RU high and has adjustable fiber guides for fiber routing. The empty slots are covered with dummy covers. The panel is shipped with USB 2.0 connectors that are connected to the corresponding dummy covers. The plastic transparent cover can be installed in front of the panel for fiber protection. The panel is designed to fit a 19-inch rack. The panel can also be installed on ETSI and 23-inch rack using adapter brackets.

The breakout panel supports the following breakout modules:

NCS1K-BRK-8

The NCS1K-BRK-8 module provides the breakout of 16 fibers from an MPO-24 connector to 8 duplex line card connectors. It essentially performs an optical connection adaptation of MPO-to-LC connectors for the ADD/DROP signals of the MPO ports of OLT line cards. For each port (MPO and LC), power monitors with tone detection capability are available. A filtered optical loopback (191.175 THz) from one MPO input port (fiber-1) to all MPO output ports is available for connection verification.

The following image displays the port connection between BRK-8 and OLT-C cards.

Figure 2: BRK-8 Panel Port Connection with OLT-C Cards

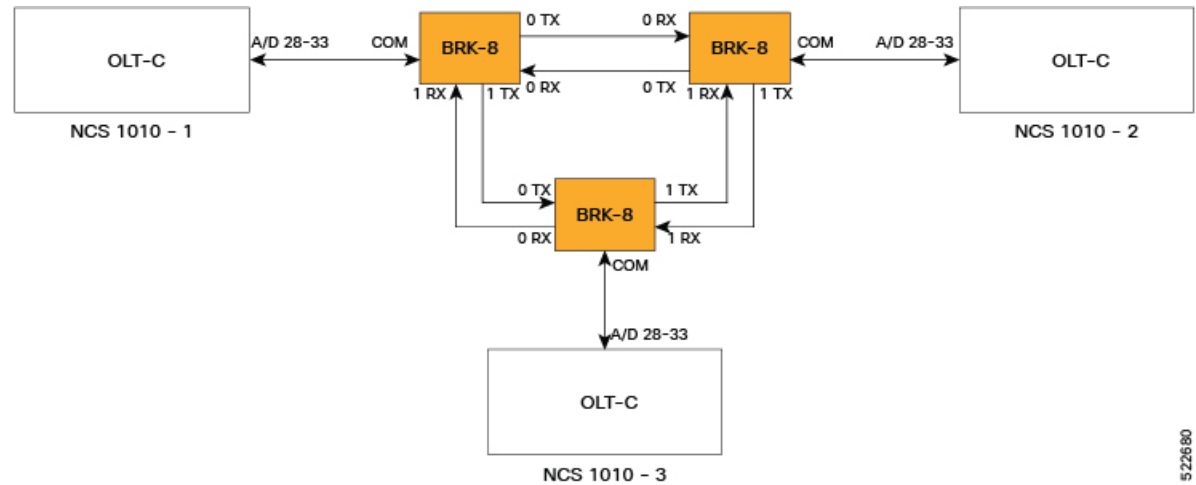

522680

NCS1K-BRK-24

The NCS1K-BRK-24 module provides the breakout of 16 fibers from an MPO-24 connector to 24 duplex LC connectors. The signals on each fiber from the MPO input ports are split over three LC output ports by a 1x3 optical splitter. The signals from the three adjacent input LC ports are combined into a single MPO fiber output port through a 1x3 optical coupler. For each port (MPO and LC), power monitors with tone detection capability are available. A filtered optical loopback (191.175 THz) from one MPO input port (fiber-1) to all MPO output ports is available for connection verification.

The following image displays port connections between BRK-24 panel and NCS 1010 and NCS 1004 chassis.

Figure 3: Port Connections Between BRK-24 Panel and NCS 1010 and NCS 1004 Chassis

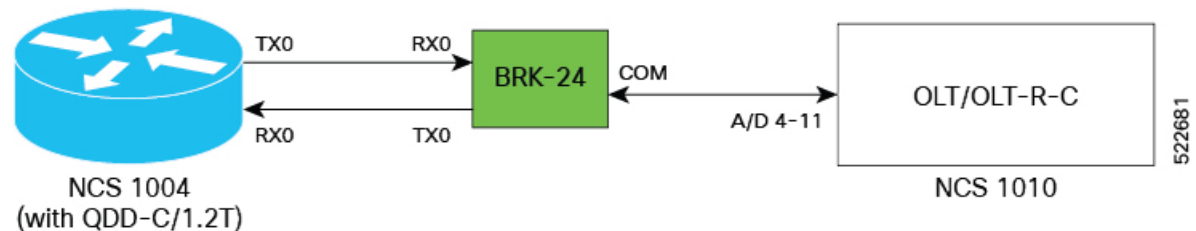

522681

Cisco NCS 1000 32-Channel Mux/Demux Patch Panels

The Cisco NCS 1000 32-Channel Mux/Demux patch panels are a pair of passive Athermal Arrayed Waveguide Grating (AAWG) based modules (PIDs NCS1K-MD-32O-C and NCS1K-MD-32E-C). Each Mux/Demux panel has 32 channels and works as an add/drop unit for the OLT-C and OLT-R-C line cards. Each Mux/Demux panel allows the multiplexing and demultiplexing of 32 channels with 150-GHz spacing. 75-GHz frequency shift exists between the ODD and EVEN panels. When both panels are used on the same OLT (OLT-C and OLT-R-C) line cards, the combined capacity becomes 64 channels with 75-GHz spacing. Each Mux/Demux panel provides a wide optical pass-band support. When used as a standalone, each panel acts as an add/drop unit for 32 channels at 140 GBd.

The NCS1K-MD-32O/E-C panel operates in C-band.

The Cisco NCS 1000 Mux/Demux patch panels are fully passive. The units are powered with a USB 2.0 connection in the NCS 1010 chassis. The panels are capable of monitoring channel power, verifying connection, detecting tone, and reporting the inventory data.

The following image displays the port connection between the Mux/Demux panels and NCS 1010 and routers.

Figure 4: Port Connection between the Mux/Demux Panels and NCS 1010 and Routers

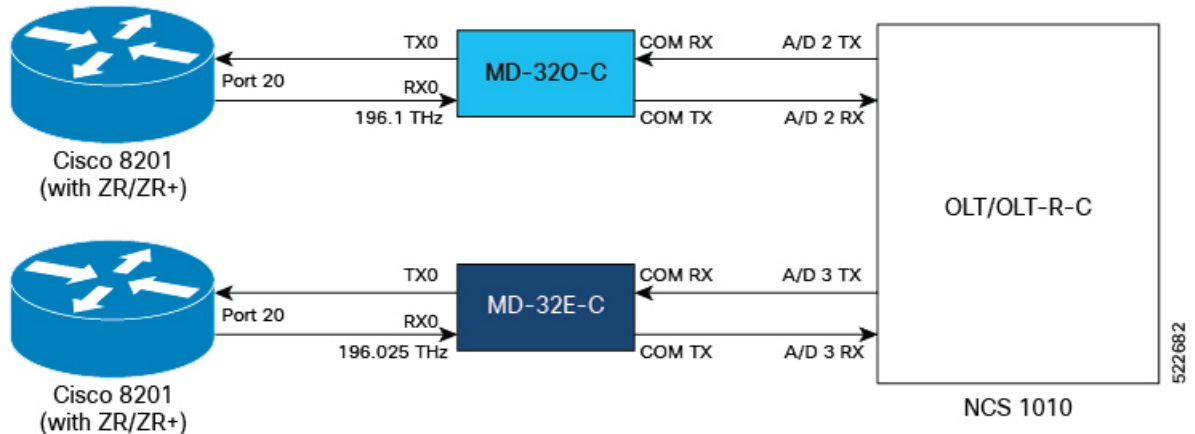

Document Objective

Cisco Network Convergence System (NCS) 1010 platform has the following configuration guides.

- The *Cisco NCS 1010 System Setup and Software Installation Guide* describes how to bring up the NCS 1010 system and perform the required software installation.
- The *Cisco NCS 1010 Datapath Configuration Guide* describes how to configure various datapaths on NCS 1010.
- The *Cisco NCS 1010 Optical Applications Configuration Guide* describes multiple optical applications on NCS 1010, that help to bring up the link and maintain traffic on the link.

Document Organization

This document is organized into the following chapters:

Chapter	Description
Bring-up Cisco NCS 1010, on page 9	Various methods such as iPXE, Zero Touch Provisioning, and USB drive to boot up the Cisco NCS 1010 system .
Disaster Recovery, on page 35	The disaster recovery process and the health check of backup ISO image.

Chapter	Description
Perform Preliminary Checks, on page 37	Preliminary checks to be performed after successfully logging into the console and the suggested corrective actions if any setup issue is detected.
Upgrade Software and FPD, on page 51	Procedures to upgrade the Cisco IOS XR software and FPDs.
Remote Node Management in NCS 1010	Manage an ILA node remotely in NCS 1010.



CHAPTER 2

Bring-up Cisco NCS 1010

After installing the hardware, boot the Cisco NCS 1010 system. You can connect to the XR console port and power on the system. NCS 1010 completes the boot process using the pre-installed operating system (OS) image. If no image is available, NCS 1010 can be booted using the iPXE boot or an external bootable USB drive.

After booting, create the root username and password, and then use it to log on to the XR console.



Note The output of the examples in the procedures is not from the latest software release. The output will change for any explicit references to the current release.

- [Boot NCS 1010, on page 9](#)
- [Configure Management Interface, on page 28](#)
- [Configure Telnet, on page 33](#)
- [Configure SSH, on page 33](#)

Boot NCS 1010

Use the console port to connect to NCS 1010. By default, the console port connects to the XR mode. If necessary, you can establish subsequent connections through the management port, after it is configured.

Step 1 Connect a terminal to the console port of the RP.

Step 2 Start the terminal emulation program on your workstation.

The console settings are 115,200 bps, 8 data bits, 1 stop bit and no parity.

Step 3 Power on NCS 1010.

To power on the shelves, install the AC or DC power supplies and cables. As NCS 1010 boots up, you can view the boot process details at the console of the terminal emulation program.

Step 4 Press **Enter**.

The boot process is complete when the system prompts you to enter the root-system username. If the prompt does not appear, wait for a while to give NCS 1010 more time to complete the initial boot procedure; then press **Enter**.

Important If the boot process fails, it may be because the preinstalled image on the NCS 1010 is corrupt. In this case, you can boot NCS 1010 using an external bootable USB drive.

Boot NCS 1010 Using USB Drive

The bootable USB drive is used to reimage NCS 1010 for system upgrade or to boot the NCS 1010 in case of boot failure. A bootable USB drive is created by copying a compressed boot file into a USB drive. The USB drive becomes bootable after the contents of the compressed file are extracted.

You can complete this task using the Windows, Linux, or MAC operating systems available on your local machine. The exact operation to be performed for each generic step that is outlined here depends on the operating system in use.

Use this task to boot the NCS 1010 using the USB drive.

Before you begin

- You need a USB drive with a storage capacity of at least 4 GB.
- The USB drive should have a single partition.
- NCS 1010 software image can be downloaded from Software Download page on Cisco.com.
- Copy the compressed boot file from the software download page at Cisco.com to your local machine. The filename for the compressed boot file is in the format *ncs1010-usb-boot-<release_number>.zip*.

-
- Step 1** Connect the USB drive to your local machine and format it with the FAT32 file system.
- Step 2** Copy the compressed boot file to the USB drive.
- Step 3** Verify that the copy operation is successful. To verify, compare the file size at source and destination. Also, verify the MD5 checksum value.
- Step 4** Extract the content of the compressed boot file by unzipping it in the USB drive. This makes the USB drive a bootable drive.
- Note** You must extract the contents of the zipped file ("EFI" and "boot" directories) directly in the root folder of the USB drive. If the unzipping application places the extracted files in a new folder, move the "EFI" and "boot" directories to the root folder of the USB drive.
- Step 5** Insert the USB drive in one of the USB ports of NCS 1010 line card/controller card.
- Step 6** Reboot NCS 1010 using power cycle or console.
- Note** Use the **reload bootmedia usb noprompt** command to boot the NCS 1010 from the USB. If you are using the **reload bootmedia usb noprompt** command, then you can skip the remaining steps.
- Step 7** Press **Esc** to enter BIOS.
- Step 8** Select the **Save & Exit** tab of BIOS.

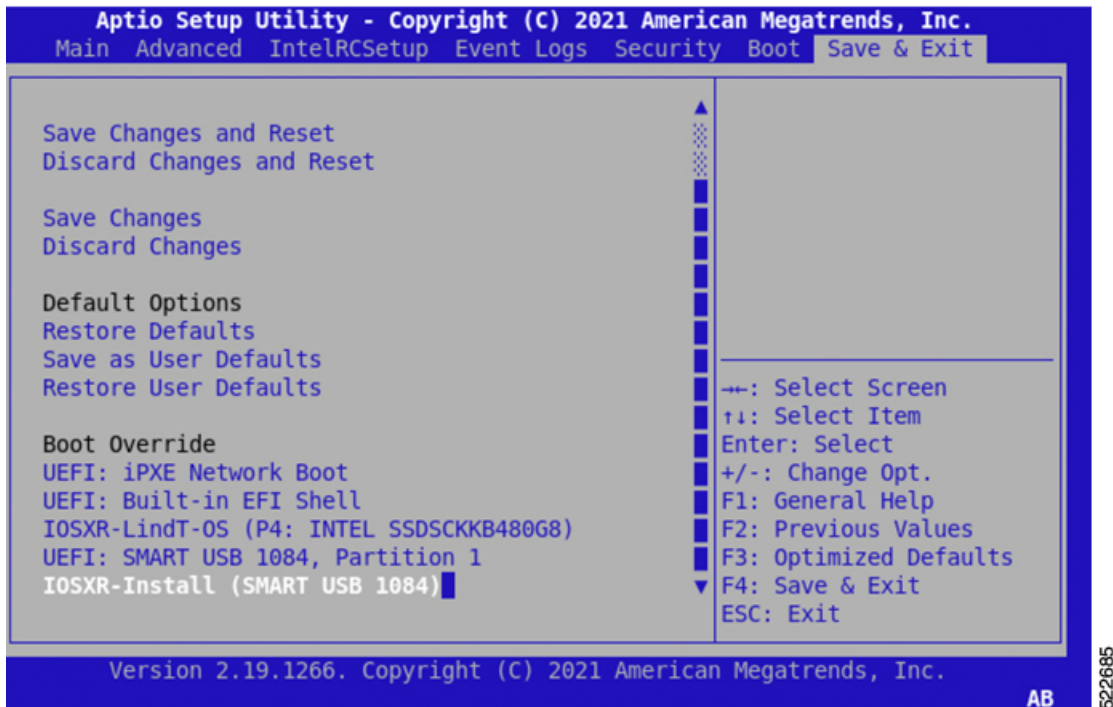

Step 9 Choose **IOS -XR Install**.

The BIOS UI displays the USB drive vendor in the brackets, in this case, SMART USB 1084.

The system detects USB and boots the image from USB.

```

Booting from USB..
Loading Kernel..
Verifying (loop)/boot/bzImage..
(loop)/boot/bzImage verified using attached signature.
Loading initrd..
Verifying (loop)/boot/initrd.img...

```

Step 10 Remove the USB drive after the Rebooting the system after installation message is displayed. The NCS 1010 reboots automatically.

Note The USB must be removed only after the image is loaded successfully.

DHCP Configuration

DHCP configuration is required for both manual configuration and ZTP configuration. Follow the below sections to set up DHCP for booting NCS 1010 using ZTP and iPXE.

Introduction to DHCP Relay

A DHCP relay agent is a host that forwards DHCP packets between clients and servers that do not reside on a shared physical subnet. Relay agent forwarding is distinct from the normal forwarding of an IP router where IP datagrams are switched between networks transparently.

DHCP clients use User Datagram Protocol (UDP) broadcasts to send DHCPDISCOVER messages when they lack information about the network to which they belong.

If a client is on a network segment that does not include a server, a relay agent is needed on that network segment to ensure that DHCP packets reach the servers on another network segment. UDP broadcast packets are not forwarded, because most routers are not configured to forward broadcast traffic. You can configure a DHCP relay agent to forward DHCP packets to a remote server by configuring a DHCP relay profile and configure one or more helper addresses in it. You can assign the profile to an interface or a VRF.

The figure below demonstrates the process. The DHCP client broadcasts a request for an IP address and additional configuration parameters on its local LAN. Acting as a DHCP relay agent, Router B picks up the broadcast, changes the destination address to the DHCP server's address and sends the message out on another interface. The relay agent inserts the IP address of the interface, on which the DHCP client's packets are received into the gateway address (giaddr) field of the DHCP packet, which enables the DHCP server to determine which subnet should receive the offer and identify the appropriate IP address range. The relay agent unicasts the messages to the server address, in this case 172.16.1.2 (which is specified by the helper address in the relay profile).

Figure 5: Forwarding UDP Broadcasts to a DHCP Server Using a Helper Address

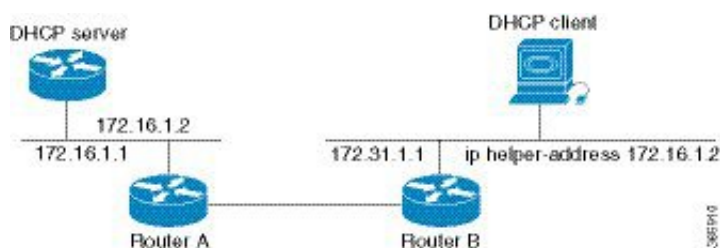

Prerequisites for Configuring DHCP Relay Agent

The following are the prerequisites to configure a DHCP relay agent:

- You must be in a user group associated with a task group that includes the proper task IDs. The command reference guides include the task IDs required for each command. If you suspect user group assignment is preventing you from using a command, contact your AAA administrator for assistance.
- A configured and running DHCP client and DHCP server.
- Connectivity between the relay agent and DHCP server

Limitations for DHCP Relay Feature

These are the limitations for implementing DHCP relay feature:

- The multicast addresses are not supported. The **helper-address** command in DHCP relay profile submode supports valid unicast IP address as the helper address.



Note Configuring the **helper-address** command directly (not using profile) under a interface (such as BVI interface) is not supported.

- Only interface-id and remote-id DHCP option code are added by a relay agent while forwarding the packet to a DHCP server.



Note Configuring DHCP option code is not supported in DHCP relay profile submode.

Configuring and Enabling the DHCP Relay Agent

Configuration Example

```
RP/0/RP0/CPU0:ios# configure
RP/0/RP0/CPU0:ios(config)# dhcp ipv4
RP/0/RP0/CPU0:ios(config-dhcpv4)# profile r1 relay
RP/0/RP0/CPU0:ios(config-dhcpv4-relay-profile)# helper-address vrf default 198.51.100.1
giaddr 198.51.100.3
RP/0/RP0/CPU0:ios(config-dhcpv4-relay-profile)# !
RP/0/RP0/CPU0:ios(config-dhcpv4-relay-profile)# interface GigabitEthernet0/0/0/2 relay
profile r1
RP/0/RP0/CPU0:ios(config-dhcpv4)# commit
```

Running Configuration

```
RP/0/RP0/CPU0:ios# show running-config dhcp ipv4
Tue Aug 29 07:30:50.677 UTC
dhcp ipv4
  profile r1 relay
    helper-address vrf default 198.51.100.1 giaddr 198.51.100.3
  !
  interface GigabitEthernet0/0/0/2 relay profile r1
  !
```

DHCP Client

The Dynamic Host Configuration Protocol (DHCP) client functionality enables the router interfaces to dynamically acquire the IPv4 or DHCPv4 or DHCPv6 server, and forwards the responses back to the correct Layer 2 address so that the correct device gets the correct configuration information.

DHCP has the ability to allocate IP addresses only for a configurable period of time, called the lease period. If the client is required to retain this IP address for a longer period beyond the lease period, the lease period must be renewed before the IP address expires. The client renews the lease based on configuration that was sent from the server. The client unicasts a REQUEST message using the IP address of the server. When a server receives the REQUEST message and responds with an ACK message. The lease period of the client is extended by the lease time configured in the ACK message.

Enabling DHCP Client on an Interface

You can enable both the DHCPv4 and DHCPv6 clients at an interface level. The DHCP component receives a notification when DHCPv4 or DHCPv6 is enabled or disabled on an interface.

```
RP/0/RP0/CPU0:ios# configure
Tue Aug 29 09:26:12.468 UTC
RP/0/RP0/CPU0:ios(config)# int mgmtEth 0/RP0/CPU0/0
RP/0/RP0/CPU0:ios(config-if)# ipv4 address dhcp
RP/0/RP0/CPU0:ios(config-if)# commit
Tue Aug 29 09:26:21.715 UTC
RP/0/RP0/CPU0:ios(config-if)# exit
RP/0/RP0/CPU0:ios(config)# int mgmtEth 0/RP0/CPU0/0
RP/0/RP0/CPU0:ios(config-if)# ipv6 address dhcp
```

```

dhcp dhcp-client-options
RP/0/RP0/CPU0:ios(config-if)# ipv6 address dhcp
RP/0/RP0/CPU0:ios(config-if)# commit
Tue Aug 29 09:26:50.159 UTC

```

Boot Using iPXE

iPXE is a pre-boot execution environment that is included in the network card of the management interfaces and works at the system firmware (UEFI) level of the chassis. iPXE is used to reimage the system, and boot the chassis in case of boot failure or in the absence of a valid bootable partition. iPXE downloads the ISO image, proceeds with the installation of the image, and finally bootstraps inside the new installation.



Note The time taken for iPXE to download the ISO image depends on the network speed. Ensure that the network speed is sufficient to complete the image download in less than 10 minutes. The chassis reloads if the image is not downloaded by 10 minutes.

iPXE acts as a bootloader and provides the flexibility to choose the image that the system will boot based on the Platform Identifier (PID), the Serial Number, or the management MAC-address. You must define iPXE in the DHCP server configuration file.



Note To initiate the iPXE boot process, perform one of the following methods:

- Use the **reload bootmedia network location all** command. This method is the preferred method.
- Power cycle the NCS 1010 chassis and start the iPXE boot process in the BIOS interface.

Setup DHCP Server

A DHCP server must be configured for IPv4, IPv6, or both communication protocols.



Note For DHCPv6, a routing advertisement (RA) message must be sent to all nodes in the network that indicates which method is to be used to obtain the IPv6 address. Configure Router-advertise-daemon (radvd, install using `yum install radvd`) to allow the client to send the DHCP request. For example:

```

interface eth3
{
    AdvSendAdvert on;
    MinRtrAdvInterval 60;
    MaxRtrAdvInterval 180;
    AdvManagedFlag on;
    AdvOtherConfigFlag on;
    prefix 2001:1851:c622:1::/64
    {
        AdvOnLink on;
        AdvAutonomous on;
        AdvRouterAddr off;
    };
};

```

To setup a DHCP server:

1. Create the `dhcpd.conf` file (for IPv4, IPv6 or both communication protocols), `dhcpv6.conf` file (for IPv6) or both in the `/etc/` directory. This configuration file stores the network information such as the path to the script, location of the ISO install file, location of the provisioning configuration file, serial number, MAC address of the chassis.
2. Test the server once the DHCP server is running:

For example, for ipv4:

- a. Use MAC address of the chassis:

```
host ncs1010
{
hardware ethernet ab:cd:ef:01:23:45;
fixed-address <ip address>;
filename "http://<httpserver-address>/<path-to-image>/ncs1010-mini-x.iso";
}
```

Ensure that the above configuration is successful.

- b. Use serial number of the chassis:

```
host demo {
option dhcp-client-identifier "<chassis-serial-number>";
filename "http://<IP-address>/<hardware-platform>-mini-x.iso";
fixed-address <IP-address>;
}
```

The serial number of the chassis is derived from the BIOS and is used as an identifier.

Example

```
host 10.89.205.202 {
hardware ethernet 40:55:39:56:0c:e8;
option dhcp-client-identifier "<FCB2437B066>";
if exists user-class and option user-class = "iPXE" {
filename "http://10.89.205.127/box1/ncs1010-x64.iso";
} else {
filename "http://10.89.205.127/box1/StartupConfig.cfg";
}
fixed-address 10.89.205.202;
}
```

Boot Using iPXE

Before you use the iPXE boot, ensure that:

- DHCP server is set and is running.
- Management port of the NCS 1010 chassis is in *UP* state.

Use anyone of the following methods to invoke the iPXE boot process:

- via CLI terminal:

Run the following command to invoke the iPXE boot process to reimage the chassis:

```
reload bootmedia network location all
```

Example:

```
RP/0/RP0/CPU0:ios# reload bootmedia network location all
Wed Jul  6 15:11:33.791 UTC
Reload hardware module ? [confirm]
```

The following example shows the output of the command:

Preparing system for backup. This may take a few minutes especially for large configurations.

```
Status report: node0_RP0_CPU0: BACKUP INPROGRESS
RP/0/RP0/CPU0:PlD_DT# Status report: node0_RP0_CPU0: BACKUP HAS COMPLETED SUCCESSFULLY
```

```
[Done]
[FAILED] Failed unmounting /mnt/fuse/parser_server.
[ OK ] Unmounted /mnt/fuse/ftp.
[ OK ] Unmounted /mnt/fuse/nvgen_server.
[ OK ] Unmounted /boot/efi.
[ OK ] Unmounted /selinux.
```

```
.
```

Output Snipped

```
.
```

```
.
```

```
..          *** Sirius ***
```

```
System Initializing..
```

```
..
```

```
ERROR: Class:0; Subclass:10000; Operation: 1004
```

```
Shelf Assembly Reset
```

```
Shelf Assembly Reset for P1
```

```
..          *** Sirius ***
```

```
System Initializing..
```

```
..
```

```
ERROR: Class:0; Subclass:10000; Operation: 1004
```

```
.
```

```
.
```

Output Snipped

```
.
```

```
.
```

NCS1010, Initializing Devices

Booting from Primary Flash

Aldrin: Programmed MI 10

```
.
```

```
.
```

Output Snipped

```
.
```

```
.
```

Version 2.19.1266. Copyright (C) 2022 American Megatrends, Inc.

BIOS Date: 05/20/2022 10:47:39 Ver: 0ACHIO410

Press or <ESC> to enter setup.

TAM Chipguard Validate Observed DB Error: 0x48

WARNING!!! TAM: Empty Chip DB

Software Boot OK, Validated

iPXE initialising devices...ok

```

iPXE 1.0.0+ (c2215) -- Open Source Network Boot Firmware -- http://ipxe.org
Features: DNS HTTP TFTP VLAN EFI ISO9660 ISO9660_grub Menu
Trying net0-2051,net0-2052 and net0-2053...
net0-2051: 68:9e:0b:b8:71:1e using NII on NII-PCI06:00.0 (open)
  [Link:down, TX:0 TXE:0 RX:0 RXE:0]
  [Link status: Unknown (http://ipxe.org/1a086194)]
Configuring (net0-2051 68:9e:0b:b8:71:1e)..... Error 0x040ee186
(http://ipxe.org/040ee186)
net0-2052: 68:9e:0b:b8:71:1f using NII on NII-PCI06:00.0 (open)
  [Link:up, TX:0 TXE:0 RX:18 RXE:14]
  [RXE: 8 x "Operation not supported (http://ipxe.org/3c086083)"]
  [RXE: 3 x "Error 0x440e6083 (http://ipxe.org/440e6083)"]
  [RXE: 3 x "The socket is not connected (http://ipxe.org/380f6093)"]
Configuring (net0-2052 68:9e:0b:b8:71:1f)..... ok
net0: fe80::6a9e:bff:feb8:711e/64
net1: fe80::6a9e:bff:feb8:7121/64 (inaccessible)
net2: fe80::6a9e:bff:feb8:7122/64 (inaccessible)
net3: fe80::6a9e:bff:feb8:7123/64 (inaccessible)
net0-2051: fe80::6a9e:bff:feb8:711e/64
net0-2051: 2001:420:5446:2014::281:0/119 gw fe80::676:b0ff:fed8:c100 (no address)
net0-2051: 2002:420:54ff:93:6a9e:bff:feb8:711e/64 gw fe80::fa4f:57ff:fe72:a640
net0-2052: 10.4.33.44/255.255.0.0 gw 10.4.33.1
net0-2052: fe80::6a9e:bff:feb8:711e/64
net0-2053: fe80::6a9e:bff:feb8:711e/64
Filename: http://10.4.33.51/P1D_DT_05/ncs1010-x64.iso
http://10.4.33.51/P1D_DT_05/ncs1010-x64.iso... ok
.
.
Output Snipped
.
.
User Access Verification

Username: cisco
Password:

```

- via BIOS interface:
 1. Reboot NCS 1010 using power cycle or console.
 2. Press **Esc** to enter BIOS.
 3. Select the **Save & Exit** tab of BIOS.
 4. Choose **UEFI: iPXE Network Boot**.

The following example shows the output of the command:

```

Preparing system for backup. This may take a few minutes especially for large
configurations.
  Status report: node0_RP0_CPU0: BACKUP INPROGRESS
RP/0/RP0/CPU0:P1D_DT#  Status report: node0_RP0_CPU0: BACKUP HAS COMPLETED
SUCCESSFULLY
[Done]
[FAILED] Failed unmounting /mnt/fuse/parser_server.
[ OK ] Unmounted /mnt/fuse/ftp.
[ OK ] Unmounted /mnt/fuse/nvgen_server.
[ OK ] Unmounted /boot/efi.
[ OK ] Unmounted /selinux.
.
.
Output Snipped
.
.

```

```

..          *** Sirius ***
System Initializing..
..

ERROR: Class:0; Subclass:10000; Operation: 1004

Shelf Assembly Reset
Shelf Assembly Reset for P1

..          *** Sirius ***
System Initializing..
..

ERROR: Class:0; Subclass:10000; Operation: 1004
.
.
Output Snipped
.
.

NCS1010, Initializing Devices

Booting from Primary Flash
Aldrin: Programmed MI 10
.
.
Output Snipped
.
.
Version 2.19.1266. Copyright (C) 2022 American Megatrends, Inc.
BIOS Date: 05/20/2022 10:47:39 Ver: 0ACHI0410
Press <DEL> or <ESC> to enter setup.
TAM Chipguard Validate Observed DB Error: 0x48

WARNING!!! TAM: Empty Chip DB

Software Boot OK, Validated

iPXE initialising devices...ok

iPXE 1.0.0+ (c2215) -- Open Source Network Boot Firmware -- http://ipxe.org
Features: DNS HTTP TFTP VLAN EFI ISO9660 ISO9660_grub Menu
Trying net0-2051,net0-2052 and net0-2053...
net0-2051: 68:9e:0b:b8:71:1e using NII on NII-PCI06:00.0 (open)
  [Link:down, TX:0 TXE:0 RX:0 RXE:0]
  [Link status: Unknown (http://ipxe.org/1a086194)]
Configuring (net0-2051 68:9e:0b:b8:71:1e)..... Error 0x040ee186
(http://ipxe.org/040ee186)
net0-2052: 68:9e:0b:b8:71:1f using NII on NII-PCI06:00.0 (open)
  [Link:up, TX:0 TXE:0 RX:18 RXE:14]
  [RXE: 8 x "Operation not supported (http://ipxe.org/3c086083)"]
  [RXE: 3 x "Error 0x440e6083 (http://ipxe.org/440e6083)"]
  [RXE: 3 x "The socket is not connected (http://ipxe.org/380f6093)"]
Configuring (net0-2052 68:9e:0b:b8:71:1f)..... ok
net0: fe80::6a9e:bff:feb8:711e/64
net1: fe80::6a9e:bff:feb8:7121/64 (inaccessible)
net2: fe80::6a9e:bff:feb8:7122/64 (inaccessible)
net3: fe80::6a9e:bff:feb8:7123/64 (inaccessible)
net0-2051: fe80::6a9e:bff:feb8:711e/64
net0-2051: 2001:420:5446:2014::281:0/119 gw fe80::676:b0ff:fed8:c100 (no address)
net0-2051: 2002:420:54ff:93:6a9e:bff:feb8:711e/64 gw fe80::fa4f:57ff:fe72:a640

```



```
net0-2052: 10.4.33.44/255.255.0.0 gw 10.4.33.1
net0-2052: fe80::6a9e:bff:feb8:711e/64
net0-2053: fe80::6a9e:bff:feb8:711e/64
Filename: http://10.4.33.51/P1D_DT_05/ncs1010-x64.iso
http://10.4.33.51/P1D_DT_05/ncs1010-x64.iso... ok
.
.
Output Snipped
.
.
User Access Verification

Username: cisco
Password:
```

Boot Using Zero Touch Provisioning

ZTP allows you to provision the network device with day 0 configurations and supports both management ports and data ports.

ZTP provides multiple options, such as:

- Automatically apply specific configuration in a large-scale environment.
- Download and install specific IOS XR image.
- Install specific application package or third party applications automatically.
- Deploy containers without manual intervention.
- Upgrade or downgrade software versions effortlessly on thousands of network devices at a time

Benefits of Using ZTP

ZTP helps you manage large-scale service providers infrastructures effortlessly. Following are the added benefits of using ZTP:

- ZTP helps you to remotely provision a router anywhere in the network. Thus eliminates the need to send an expert to deploy network devices and reduces IT cost.
- Automated provisioning using ZTP can remove delay and increase accuracy and thus is cost-effective and provides better customer experience.

By automating repeated tasks, ZTP allows network administrators to concentrate on more important stuff.

- ZTP process helps you to quickly restore service. Rather than troubleshooting an issue by hand, you can reset a system to well-known working status.

Prerequisites:

ZTP does not execute, if a username is already configured in the system.

ZTP is initiated in one of the following ways:

- **Automated Fresh Boot:**

Fresh Boot: When you boot the device, the ZTP process initiates automatically if the device does not have a prior configuration. During the process, the router receives the details of the configuration file

from the DHCP server. Use this method for devices that has no pre-loaded configuration. See [Fresh Boot Using DHCP, on page 20](#).

You must define the configuration file or the bootscript that is downloaded from the DHCP server:

- **Configuration File:** The first line of the file must contain **!! IOS XR configuration**", to process the file as a configuration. If you are trying to bring up ten new nodes, you have to define ten configuration files. See [Build your Configuration File, on page 21](#).
- **ZTP Bootscript:** Define the script to be executed on every boot. See [Configure ZTP BootScript, on page 22](#).
- **Manual Invocation using CLI:** Use this method when you want to forcefully initiate ZTP on a fully configured device, using CLI. See [Invoke ZTP Manually through CLI, on page 24](#).

Fresh Boot Using DHCP

The ZTP process initiates when you boot the network-device with an IOS-XR image. The process starts only on the device that doesn't have a prior configuration.

This image depicts the high-level work flow of the ZTP process:

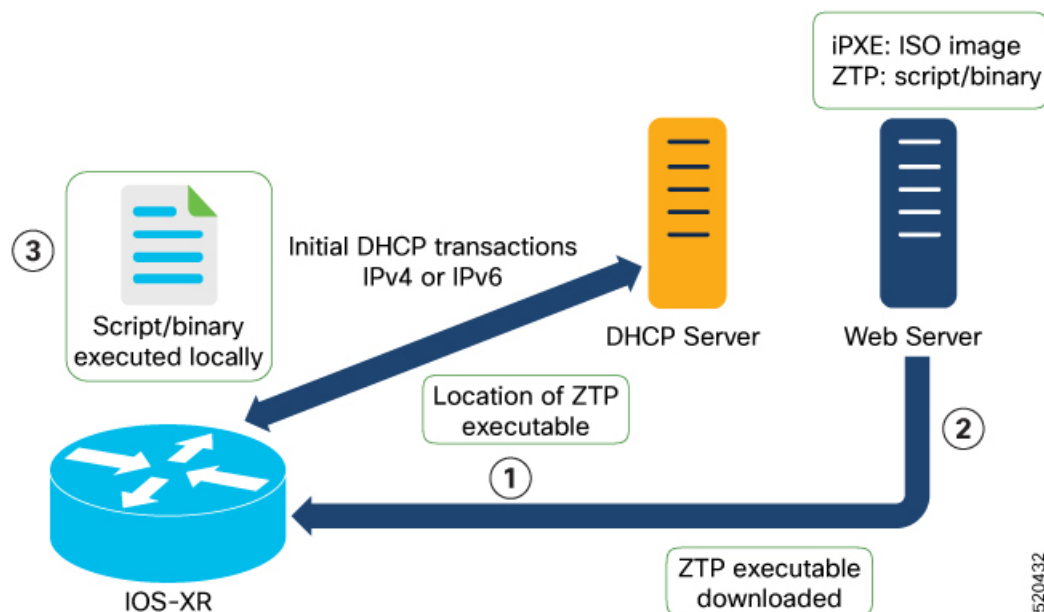

1. ZTP sends DHCP request to fetch the ZTP configuration file or user script. To help the Bootstrap server uniquely identify the device, ZTP sends below DHCP option.
 - DHCP(v4/v6) client-id=Serial Number
 - DHCPv4 option 124: Vendor, Platform, Serial-Number
 - DHCPv6 option 16: Vendor, Platform, Serial-Number

The following is the default sequential flow of the ZTP process:

- ZTP sends IPv4 DHCP request first on all the management port. In case there is a failure, then ZTP sends IPv6 DHCP request on all the management port.

- ZTP sends IPv4 DHCP request first on all the data port. In case there is a failure, then ZTP sends IPv6 DHCP request on all the data port.

The default sequential flow is defined in configuration file and you can modify the sequence using the configuration file.

2. DHCP server identifies the device and responds with DHCP response using one of the following options: DHCP server should be configured to respond with the DHCP options.
 - DHCPv4 using BOOTP filename to supply script/config location.
 - DHCPv4 using Option 67 (bootfile-name) to supply script/config location.
 - DHCPv6 using Option 59 (OPT_BOOTFILE_URL) to supply script/config location
3. The network device downloads the file from the web server using the URL location that is provided in the DHCP response.
4. The device receives a configuration file or script file from the HTTP server.



Note

- If the downloaded file content starts with !! IOS XR it is considered as a configuration file.
 - If the downloaded file content starts with #! /bin/bash, #! /bin/sh or #!/usr/bin/python it is considered as a script file.
-

5. The device applies the configuration file or executes the script or binary in the default bash shell.
6. The Network device is now up and running.

Build your Configuration File

Based on the business need, you can use a configuration or script file to initiate the ZTP process.

The configuration file content starts with !! IOS XR.

The following is the sample configuration file. You can automate all the configurations. For more information on creating ZTP configuration file, refer [ZTP Configuration Files Creation](#).

```
Tue May 4 18:08:59.544 UTC
Building configuration...
!! IOS XR Configuration 7.7.1.22I
!! Last configuration change at Tue May 4 17:12:47 2021 by cisco
!
line console
exec-timeout 0 0
!
line default
exec-timeout 0 0
session-timeout 0
!
vty-pool default 0 20
alias alarms show alarms brief system active
interface MgmtEth0/RP0/CPU0/0
ipv4 address dhcp
no shut
!
```

```

interface MgmtEth0/RP0/CPU0/1
description noshut-interface-ztp
ipv4 address 10.127.60.160 255.255.255.0
no shut
!
interface MgmtEth0/RP0/CPU0/2
description noshut-interface-ztp
no shut
!
interface PTP0/RP0/CPU0/0
description noshut-interface-ztp
no shut
Cisco NCS 1010 System Setup and Software Installation Guide, IOS XR Release 7.7.x
19
Bring-up Cisco NCS 1010
Build your Configuration File
!
telnet vrf default ipv4 server max-servers 100a
ssh server v2
ssh server netconf vrf default
netconf-yang agent
ssh
!
netconf agent tty
grpc
router static
address-family ipv4 unicast
0.0.0.0/0 10.127.60.1
end

```

Configure ZTP BootScript

ZTP downloads and executes the script files. These script files include a programmatic approach to complete a task. For example, scripts created using IOS XR commands to perform patch upgrades. The first line of the file must contain `#!/bin/bash` or `#!/bin/sh` for ZTP to process the file as script. You can either use the ZTP bash script or the ZTP configuration file.

You can either use the ZTP bash script or the ZTP configuration file.

If you want to hardcode a script to be executed every boot, configure the following.

```

Router#configure
Router(config)#ztp bootscript /disk0:/myscript
Router(config)#commit

```

The above configuration waits for the first data-plane interface to be configured and then wait an extra minute for the management interface to be configured with an IP address, to ensure that we have connectivity in the third-party namespace for applications to use. If the delay is not desired, use:

```

Router#configure
Router(config)#ztp bootscript preip /disk0:/myscript
Router(config)#commit

```



Note When the above command is first configured, you will be prompted if you wish to invoke it now. The prompt helps with testing.

This is the example content of `/disk0:/myscript`:

```

host ncs1010_P1B_DT_08_ETH0 {
#hardware ethernet 68:9e:0b:b8:6f:5c ;
option dhcp-client-identifier "FCB2437B05N" ;
if exists user-class and option user-class = "iPXE" {
filename "http://10.33.0.51/P1B_DT_08/ncs1010-x64.iso";
} else {
filename "http://10.33.0.51/P1B_DT_08/startup.cfg";
}
fixed-address 10.33.0.19;
}

```

The following is the sample content of the ZTP bash script.

```

#!/bin/bash
#
# NCS1010 Demo Sample
# ZTP installation of config and day-0 SMU's
#
source ztp_helper

wget http://downloads.sourceforge.net/project/yourcode/application.tgz
#install the downloaded application.tgz

#Run XR CLI's from the script
`xrcmd "show version"`

```

The following is the sample content of the ZTP configuration file.

```

Tue May 4 18:08:59.544 UTC
Building configuration...
!! IOS XR Configuration 7.7.1.22I
!! Last configuration change at Tue May 4 17:12:47 2021 by cisco
!
line console
exec-timeout 0 0
!
line default
exec-timeout 0 0
session-timeout 0
!
vty-pool default 0 20
alias alarms show alarms brief system active
interface MgmtEth0/RP0/CPU0/0
ipv4 address dhcp
no shut
!
interface MgmtEth0/RP0/CPU0/1
description noshut-interface-ztp
ipv4 address 10.127.60.160 255.255.255.0
no shut
!
interface MgmtEth0/RP0/CPU0/2
description noshut-interface-ztp
no shut
!
interface PTP0/RP0/CPU0/0
description noshut-interface-ztp
no shut
!
interface PTP0/RP0/CPU0/1
description noshut-interface-ztp
no shut
end

```

Invoke ZTP Manually through CLI

Manual ZTP can be invoked through CLI commands. This manual way helps you to provision the router in stages. Ideal for testing out ZTP configuration without a reboot. If you want to invoke a ZTP on an interface (data ports or management port), you don't have to bring up and configure the interface first. You can execute the `ztp initiate` command, even if the interface is down, ZTP script brings it up and invoke `dhclient`. So ZTP could run over all interfaces no matter it is up or down.

Use the `ztp initiate`, `ztp terminate`, and `ztp clean` commands to force ZTP to run over more interfaces.

- `ztp initiate`—Invokes a new ZTP DHCP session. Logs can be found in `/disk0:/ztp/ztp.log`.
- `ztp terminate`—Terminates any ZTP session in progress.
- `ztp clean`—Removes only the ZTP state files.

The log file `ztp.log` is saved in `/var/log/ztp.log` folder, and a copy of log file is available at `/disk0:/ztp/ztp.log` location using a soft link. However, executing `ztp clean` clears files saved on disk and not on `/var/logztp.log` folder where current ZTP logs are saved. In order to have a log from current ZTP run, you must manually clear the ZTP log file from `/var/log/ztp.log` folder.

Step 1 (optional) `ztp clean`

Example:

```
RP/0/RP0/CPU0:ios#ztp clean
Fri Apr 29 06:49:29.760 UTC
This would remove all ZTP temporary files.
Would you like to proceed? [no]: yes
All ZTP operation files have been removed.
ZTP logs are present in /var/log/ztp*.log for logrotate.
Please remove manually if needed.
If you now wish ZTP to run again from boot, do 'conf t/commit replace' followed by reload.
```

Removes all the ZTP logs and saved settings.

Step 2 `ztp initiate`

Example:

```
RP/0/RP0/CPU0:ios#ztp initiate
Fri Jun 17 11:44:08.791 UTC
Initiating ZTP may change your configuration.
Interfaces might be brought up if they are in shutdown state
Would you like to proceed? [no]: yes
ZTP will now run in the background.
Please use "show logging" or look at /var/log/ztp.log to check progress.
RP/0/RP0/CPU0:ios#
```

Use the **show logging** command or see the `/var/log/ztp.log` to check progress.

Reboots the Cisco NCS 1010 system.

Step 3 (Optional) `ztp terminate`

Example:

```
RP/0/RP0/CPU0:ios#ztp terminate
Fri Apr 29 06:38:59.238 UTC
This would terminate active ZTP session if any (this may leave your system in a partially configured state)
```

```
Would you like to proceed? [no]: yes
Terminating ZTP
No ZTP process running
```

Terminates the ZTP process.

Invoke ZTP Through Reload

The ZTP process can be automatically invoked by using the reload command.

Step 1 configure

Example:

```
RP/0/RP0/CPU0:P2B_DT_02#configure
```

Enters the configuration mode.

Step 2 commit replace

Example:

```
Fri Apr 29 06:48:46.236 UTC
RP/0/RP0/CPU0:P2B_DT_02(config)#commit replace
Fri Apr 29 06:48:53.199 UTC
```

This commit will replace or remove the entire running configuration. This operation can be service affecting.

```
Do you wish to proceed? [no]: yes
RP/0/RP0/CPU0:ios(config)#
RP/0/RP0/CPU0:ios(config)#end
```

Removes the entire running configuration.

Step 3 ztp clean

Example:

```
RP/0/RP0/CPU0:ios#ztp clean
Fri Apr 29 06:49:29.760 UTC
This would remove all ZTP temporary files.
Would you like to proceed? [no]: yes
All ZTP operation files have been removed.
ZTP logs are present in /var/log/ztp*.log for logrotate.
Please remove manually if needed.
If you now wish ZTP to run again from boot, do 'conf t/commit replace' followed by reload.
```

Removes all the ZTP logs and saved settings.

Step 4 reload

Example:

```
RP/0/RP0/CPU0:ios#reload
Fri Apr 29 06:50:12.312 UTC
Proceed with reload? [confirm]
```

```
RP/0/RP0/CPU0:ios#
Preparing system for backup. This may take a few minutes especially for large configurations.
Status report: node0_RP0_CPU0: BACKUP INPROGRESS
Status report: node0_RP0_CPU0: BACKUP HAS COMPLETED SUCCESSFULLY
[Done]
```

After the node comes up, you can check that the ZTP is initiated and the configuration has been restored successfully.

```
RP/0/RP0/CPU0:Apr 29 06:55:33.242 UTC: pyztp2[377]: %INFRA-ZTP-4-CONFIG_INITIATED : ZTP has initiated
  config load and commit operations
RP/0/RP0/CPU0:Apr 29 06:55:39.263 UTC: ifmgr[381]: %PKT_INFRA-LINK-3-UPDOWN : Interface
  GigabitEthernet0/0/0/0, changed state to Down
RP/0/RP0/CPU0:Apr 29 06:55:39.287 UTC: osa_driver[183]: %PKT_INFRA-FM-4-FAULT_MINOR : ALARM_MINOR
  :PROV-INPROGRESS :DECLARE :GigabitEthernet0/0/0/0:
RP/0/RP0/CPU0:Apr 29 06:55:39.287 UTC: osa_driver[183]: %PKT_INFRA-FM-4-FAULT_MINOR : ALARM_MINOR
  :PROV-INPROGRESS :DECLARE :Osc0/0/0/0:
RP/0/RP0/CPU0:Apr 29 06:55:39.287 UTC: ifmgr[381]: %PKT_INFRA-LINK-3-UPDOWN : Interface
  GigabitEthernet0/0/0/0, changed state to Up
RP/0/RP0/CPU0:Apr 29 06:55:39.716 UTC: osa_driver[183]: %PKT_INFRA-FM-4-FAULT_MINOR : ALARM_MINOR
  :PROV-INPROGRESS :CLEAR :Osc0/0/0/0:
RP/0/RP0/CPU0:Apr 29 06:55:39.728 UTC: osa_driver[183]: %PKT_INFRA-FM-4-FAULT_MINOR : ALARM_MINOR
  :PROV-INPROGRESS :CLEAR :GigabitEthernet0/0/0/0:
RP/0/RP0/CPU0:Apr 29 06:55:47.904 UTC: osa_driver[183]: %PKT_INFRA-FM-4-FAULT_MINOR : ALARM_MINOR
  :PROV-INPROGRESS :DECLARE :Ots0/0/0/1:
```

User Access Verification

```
Username: cisco
Password:
ios con0/RP0/CPU0 is now available
```

Reboots the Cisco NCS 1010 system.

ZTP Logging

ZTP logs its operation on the flash file system in the directory `/disk0:/ztp/`. ZTP logs all the transaction with the DHCP server and all the state transition.

The following example displays the execution of a simple configuration script downloaded from a data interface using the command `ztp initiate interface Ten 0/0/0/0 verbose`, this script unshuts all the interfaces of the system and configure a load interval of 30 seconds on all of them.

```
2022-06-17 11:52:34,682 19292 [Xr          ] INF: Downloading the file to /tmp/ztp.script
2022-06-17 11:52:35,329 19292 [Report      ] INF: User script downloaded successfully.
Provisioning in progress.
2022-06-17 11:52:35,330 19292 [Engine     ] DEB: ZAdmin, current state:active. Processing
  work: Config device work for ZAdmin. done = False
2022-06-17 11:52:35,330 19292 [ZAdmin     ] DEB: Proceeding to provision the router
2022-06-17 11:52:35,331 19292 [Engine     ] DEB: ZAdmin, current state:active. Processing
  work: ZAdmin: Apply configuration. done = False
2022-06-17 11:52:35,331 19292 [Engine     ] INF: ZAdmin, current state:active: state tag
  changed to provision
RP/0/RP0/CPU0:Jun 17 11:52:35.341 UTC: pyztp2[140]: %INFRA-ZTP-4-CONFIG_INITIATED : ZTP has
  initiated config load and commit operations
2022-06-17 11:52:35,339 19292 [Env        ] DEB: No MTU configs detected
2022-06-17 11:52:35,340 19292 [Engine     ] DEB: ZAdmin, current state:active. Processing
  work: ZAdmin: Apply configuration. done = False
2022-06-17 11:52:35,354 19292 [Xr          ] DEB: Will apply the following config:
/disk0:/ztp/customer/config.candidate
2022-06-17 11:52:35,354 19292 [Xr          ] INF: Applying user configurations
2022-06-17 11:52:35,355 19292 [Configuration] INF: Provisioning via config replace
2022-06-17 11:52:54,656 19292 [Configuration] INF: Configuration has been applied
2022-06-17 11:52:54,656 19292 [Engine     ] DEB: ZAdmin, current state:active. Processing
```



```

work: Sending standby sync message. done = False
2022-06-17 11:52:54,663 19292 [Engine      ] DEB: ZAdmin, current state:active. Processing
work: [privileged] getting engine status. done = False
2022-06-17 11:52:54,664 19292 [Engine      ] DEB: ZAdmin, current state:active. Processing
work: ZAdmin: Execute post-configuration script. done = False
2022-06-17 11:52:55,212 19292 [Env         ] INF: Env::cleanup, success:True, exiting:False
2022-06-17 11:52:55,213 19292 [ZtpHelpers  ] DEB: Executing: source /pkg/bin/ztp_helper.sh
&& echo -ne | xrcmd "show running-config"
2022-06-17 11:52:55,825 19292 [Env         ] INF: Executing command ip netns exec
vrf-default /sbin/dhclient -4 -cf /etc/dhcp/dhclient.conf.ztp -lf
/var/lib/dhcp/dhclient.leases.ztp -sf /etc/dhcp/dhclient-script.ztp2 -r Mg0_RP0_CPU0_0 to
release IP
2022-06-17 11:52:56,968 19292 [Xr          ] INF: Removing linux route with ip 10.33.0.63
2022-06-17 11:52:57,023 19292 [Engine      ] INF: ZAdmin, current state:active, exit
code:success
2022-06-17 11:52:57,023 19292 [Engine      ] INF: ZAdmin, current state:final, exit
code:success: state changed to final
2022-06-17 11:52:59,737 19292 [Engine      ] DEB: ZAdmin, current state:final, exit
code:success. Processing work: Sending standby sync message. done = False
2022-06-17 11:52:59,738 19292 [Engine      ] WAR: ZAdmin, current state:final, exit
code:success: work is ignored: work=<desc='Sending standby sync message' done=False
priv=False>
2022-06-17 11:52:59,738 19292 [Engine      ] DEB: ZAdmin, current state:final, exit
code:success. Processing work: [privileged] getting engine status. done = False
2022-06-17 11:53:04,744 19292 [main        ] DEB: Moved to final state
2022-06-17 11:53:04,745 19292 [main        ] DEB: ZTP completed successfully
2022-06-17 11:53:04,745 19292 [main        ] INF: Exiting SUCCESSFULLY
2022-06-17 11:53:04,746 19292 [main        ] DEB: Exiting. Will not retry now.
2022-06-17 11:53:04,746 19292 [main        ] DEB: Shutting down adaptor. Cleanup False. Exiting
False
2022-06-17 11:53:04,748 19292 [Engine      ] DEB: ZAdmin, current state:final, exit
code:success. Processing work: [privileged] prepare engine shutdown. done = False
2022-06-17 11:53:04,849 19292 [Engine      ] DEB: ZAdmin, current state:final, exit
code:success. Processing work: [privileged] shutting down ZAdmin engine. done = False
2022-06-17 11:53:04,849 19292 [Engine      ] INF: ZAdmin, current state:final, exit
code:shutdown
2022-06-17 11:53:04,849 19292 [Engine      ] INF: ZAdmin, exit code:shutdown: state changed
to None
2022-06-17 11:53:04,849 19292 [Engine      ] DEB: ZAdmin, exit code:shutdown: breaking
engine loop after shutdown
2022-06-17 11:53:04,850 19292 [Engine      ] DEB: ZAdmin, exit code:shutdown: end of event
loop
2022-06-17 11:53:04,850 19292 [Adaptor     ] DEB: Adaptor : Cleanup for admin context on
Terminate
2022-06-17 11:53:06,119 19292 [main        ] INF: Exiting SUCCESSFULLY
2022-06-17 11:53:06,119 19292 [main        ] INF: ZTP Exited
RP/0/RP0/CPU0:Jun 17 11:53:06.119 UTC: pyztp2[140]: %INFRA-ZTP-4-EXITED : ZTP exited

```

Generate Tech Support Information for ZTP

When you have a problem in the ztp process that you cannot resolve, the resource of last resort is your Cisco Systems technical support representative. To analyze a problem, your technical support representative needs certain information about the situation and the symptoms that you are experiencing. To speed up the problem isolation and resolution process, collect the necessary data before you contact your representative.

Use the **show tech-support ztp** command to collect all debugging information of ztp process.

Example:

```

RP/0/RP0/CPU0:R1#show tech-support ztp
Thu Jul 28 08:33:27.531 UTC
++ Show tech start time: 2022-Jul-28.083327.UTC ++
Thu Jul 28 08:33:28 UTC 2022 Waiting for gathering to complete

```

```

..
Thu Jul 28 08:33:34 UTC 2022 Compressing show tech output
Show tech output available at 0/RP0/CPU0 :
/harddisk:/showtech/showtech-R1-ZTP-2022-Jul-28.083327.UTC.tgz
++ Show tech end time: 2022-Jul-28.083334.UTC ++
RP/0/RP0/CPU0:R1#

```

In the above example, the tech support information is saved as .tgz file in the specified location. This information can be shared with the Cisco Technical Support representatives for troubleshooting the ztp process.

Configure Management Interface

The management interface can be used for system management and remote communication. To use the management interface for system management, you must configure an IP address and subnet mask. To use the management interface for remote communication, you must configure a static route. Use this procedure when NCS 1010 chassis is not booted using ZTP.

Before you begin

- Consult your network administrator to procure IP addresses and a subnet mask for the management interface.
- Ensure that the management interface is connected to the management network.

Step 1 **configure**

Example:

```
RP/0/RP0/CPU0:ios#configure
```

Enters IOS XR configuration mode.

Step 2 **interface mgmtEth rack/slot/instance/port**

Example:

```
RP/0/RP0/CPU0:ios(config)#interface mgmtEth 0/RP0/CPU0/0
```

Enters interface configuration mode for the management interface.

Step 3 **ipv4 address ipv4-address subnet-mask**

Example:

```
RP/0/RP0/CPU0:ios(config-if)#ipv4 address 10.1.1.1 255.0.0.0
```

Assigns an IP address and a subnet mask to the management interface.

Step 4 **no shutdown**

Example:

```
RP/0/RP0/CPU0:ios(config-if)#no shutdown
```

Places the management interface in an "up" state.

Step 5 **exit**

Example:

```
RP/0/RP0/CPU0:ios(config-if)#exit
```

Exits the management interface configuration mode.

Step 6 `router static address-family ipv4 unicast 0.0.0.0/0 default-gateway`

Example:

```
RP/0/RP0/CPU0:ios(config)#router static address-family ipv4 unicast 0.0.0.0/0 198.51.100.4
```

Specifies the IP address of the default gateway to configure a static route. This IP address must be used for communication with devices on other networks.

Step 7 Use the **commit** or **end** command.

commit-Saves the configuration changes and remains within the configuration session.

end-Prompts user to take one of these actions:

- **Yes**-Saves configuration changes and exits the configuration session.
- **No**-Exits the configuration session without committing the configuration changes.
- **Cancel**-Remains in the configuration session without committing the configuration changes.

What to do next

Connect the management interface to the Ethernet network. Establish a [Configure SSH](#) or [Configure Telnet](#) connection to the management interface using its IP address.

Link Layer Discovery Protocol Support on Management Interface

The Link Layer Discovery Protocol (LLDP) support on management interface feature requires a system to form LLDP neighbor relationship over the system management interface, through which it advertises and learns LLDP neighbor information. This information about neighbors used to learn about the neighbors and in turn the topology of the devices for Operations, Administration, and Maintenance (OAM) purposes.

Advantages of LLDP

- Provides support on non-Cisco devices.
- Enables neighbor discovery between non-Cisco devices.

Limitation

- When you disable LLDP globally, the LLDP gets disabled on all the interfaces.



Note By default, LLDP is enabled for NCS 1010. But when you enable and disable LLDP in the global configuration mode, LLDP gets disabled on all the interfaces.

Workaround: You must enable LLDP globally or reload the Router.

Cisco Discovery Protocol (CDP) vs LLDP

The CDP is a device discovery protocol that runs over Layer 2. Layer 2 is also known as the data link layer that runs on all Cisco devices, such as routers, bridges, access servers, and switches. This protocol allows the network management applications to automatically discover and learn about other Cisco devices that connect to the network.

The LLDP is also a device discovery protocol that runs over Layer 2. This protocol allows the network management applications to automatically discover and learn about other non-Cisco devices that connect to the network.

Interoperability between non-Cisco devices using LLDP

LLDP is also a neighbor discovery protocol that is used by network devices to advertise information about themselves to other devices on the network. This protocol runs over the data link layer, which allows two systems running different network layer protocols to learn about each other.

With LLDP, you can also access the information about a particular physical network connection. If you use a non-Cisco monitoring tool (through SNMP), LLDP helps you identify the Object Identifiers (OIDs) that the system supports. The following OIDs are supported:

- 1.0.8802.1.1.2.1.4.1.1.4
- 1.0.8802.1.1.2.1.4.1.1.5
- 1.0.8802.1.1.2.1.4.1.1.6
- 1.0.8802.1.1.2.1.4.1.1.7
- 1.0.8802.1.1.2.1.4.1.1.8
- 1.0.8802.1.1.2.1.4.1.1.9
- 1.0.8802.1.1.2.1.4.1.1.10
- 1.0.8802.1.1.2.1.4.1.1.11
- 1.0.8802.1.1.2.1.4.1.1.12

Neighbor Discovery

System advertises the LLDP TLV (Type Length Value) details over the management network using which other devices in the management network can learn about this device.

Configuring LLDP

- LLDP full stack functionality is supported on all three management interfaces that are supported in NCS 1010.
- You can selectively enable or disable LLDP on any of the management interfaces on demand.
- You can selectively enable or disable LLDP transmit or receive functionality at the management interface level.
- Information gathered using LLDP can be stored in the device Management Information Database (MIB) and queried with the Simple Network Management protocol (SNMP).
- LLDP operational data is available in both CLI and netconf-yang interface.

Enabling LLDP Globally

When you enable LLDP globally, all interfaces that support LLDP are automatically enabled for both transmit and receive operations.



Note You can override this default operation at the interface to disable receive or transmit operations.

The following table describes the global LLDP attributes that you can configure:

Table 1:

Attribute	Default	Range	Description
Holdtime	120	0–65535	Specifies the holdtime (in sec). Holdtime refers to the time or duration that an LLDP device maintains the neighbor information before discarding.
Reinit	2	2–5	Delay (in sec) for LLDP initialization on any interface
Timer	30	5–65534	Specifies the rate at which LLDP packets are sent (in sec)

The following example shows the commands to configure LLDP globally. The global LLDP configuration enables LLDP on all the three management interfaces.

```
RP/0/RP0/CPU0:regen#configure terminal
RP/0/RP0/CPU0:regen(config)#lldp management enable
RP/0/RP0/CPU0:regen(config)#lldp holdtime 30
RP/0/RP0/CPU0:regen(config)#lldp reinit 2
RP/0/RP0/CPU0:regen(config)#commit
```

Verification

You can verify the LLDP configuration using the **show running-config lldp** command.

The output of **show running-config lldp** command is as follows:

```
RP/0/RP0/CPU0:regen#show running-config lldp
Tue Dec 10 10:36:11.567 UTC
lldp
timer 30
reinit 2
holdtime 120
management enable
!
```

You can verify the LLDP data using the **show lldp interface** and **show lldp neighbors** commands.

The output of **show lldp interface** command is as follows:

```
RP/0/RP0/CPU0:regen#show lldp interface
Thu Nov 7 08:45:22.934 UTC
```

```
MgmtEth0/RP0/CPU0/0:
  Tx: enabled
  Rx: enabled
  Tx state: IDLE
  Rx state: WAIT FOR FRAME
```

```
MgmtEth0/RP0/CPU0/1:
  Tx: enabled
  Rx: enabled
  Tx state: IDLE
  Rx state: WAIT FOR FRAME
```

The output of **show lldp neighbors** command is as follows:

```
RP/0/RP0/CPU0:M-131#show lldp neighbors
Mon Dec  2 11:01:20.143 CET
Capability codes:
  (R) Router, (B) Bridge, (T) Telephone, (C) DOCSIS Cable Device
  (W) WLAN Access Point, (P) Repeater, (S) Station, (O) Other

Device ID           Local Intf           Hold-time  Capability  Port ID
[DISABLED]         MgmtEth0/RP0/CPU0/0  120        B           gi19
MYS-130            MgmtEth0/RP0/CPU0/1  120        R           MgmtEth0/RP0/CPU0/1
```

where [DISABLED] shows that the LLDP is disabled on the interface MgmtEth0/RP0/CPU0/0.

Enabling LLDP per Management Interface

The following example shows the commands to configure LLDP at the management interface level.

```
RP/0/RP0/CPU0:ios(config)#interface mgmtEth 0/RP0/CPU0/X
RP/0/RP0/CPU0:ios(config-if)#lldp enable
RP/0/RP0/CPU0:ios(config-if)#commit
```

Disabling LLDP Transmit and Receive Operations

The following example shows the commands to disable the LLDP transmit operations at the specified management interface.

```
RP/0/RP0/CPU0:ios(config)#interface mgmtEth 0/RP0/CPU0/X
RP/0/RP0/CPU0:ios(config-if)#lldp transmit disable
RP/0/RP0/CPU0:ios(config-if)#commit
```

The following example shows the commands to disable the LLDP receive operations at the specified management interface.

```
RP/0/RP0/CPU0:ios(config)#interface mgmtEth 0/RP0/CPU0/X
RP/0/RP0/CPU0:ios(config-if)#lldp receive disable
RP/0/RP0/CPU0:ios(config-if)#commit
```

Debugging LLDP Issues

The following commands are used for debugging issues in the LLDP functionality.

- **show lldp traffic**
- **debug lldp all**
- **debug lldp errors**
- **debug lldp events**
- **debug lldp packets**
- **debug lldp tlvs**

- `debug lldp trace`
- `debug lldp verbose`

Configure Telnet

This procedure allows you to establish a telnet session to the management interface using its IP address. Use this procedure when NCS 1010 chassis is not booted using ZTP.

Before you begin

Ensure that two `xr-telnet-*` rpms are installed. .

Step 1 `configure`

Example:

```
RP/0/RP0/CPU0:ios#configure
```

Enters the configuration mode.

Step 2 `telnet {ipv4 | ipv6} server max-servers limit`

Example:

```
RP/0/RP0/CPU0:ios(config)#telnet ipv4 server max-servers 10
```

Specifies the number of allowable telnet servers (up to 100). By default, telnet servers are not allowed. You must configure this command to enable the use of telnet servers.

Step 3 Use the `commit` or `end` command.

commit-Saves the configuration changes and remains within the configuration session.

end-Prompts user to take one of these actions:

- **Yes**-Saves configuration changes and exits the configuration session.
- **No**-Exits the configuration session without committing the configuration changes.
- **Cancel**-Remains in the configuration session without committing the configuration changes.

Configure SSH

This procedure allows you to establish an SSH session to the management interface using its IP address. Use this procedure when NCS 1010 chassis is not booted using ZTP.

Before you begin

- Generate the crypto key for SSH using the `crypto key generate dsa` command.

Step 1 **configure****Example:**

```
RP/0/RP0/CPU0:ios#configure
```

Enters the configuration mode.

Step 2 **ssh server v2****Example:**

```
RP/0/RP0/CPU0:ios(config)# ssh server v2
```

Enables the SSH server to accept only SSHv2 client connections.

Step 3 Use the **commit** or **end** command.

commit-Saves the configuration changes and remains within the configuration session.

end-Prompts the user to take one of these actions:

- **Yes**-Saves configuration changes and exits the configuration session.
 - **No**-Exits the configuration session without committing the configuration changes.
 - **Cancel**-Remains in the configuration session without committing the configuration changes.
-



CHAPTER 3

Disaster Recovery

This chapter describes the disaster recovery process and the health check feature.

- [Overview, on page 35](#)
- [CPU Replacement Considerations, on page 35](#)
- [Health Check of Backup ISO Image, on page 35](#)

Overview

There are two partitions in NCS 1010: RP SSD (CPU partition) and chassis SSD (Disaster Recovery partition). The Disaster Recovery partition contains all the backup configurations such as ISO images, RPMs, and system configuration files. When the node is corrupted, the Disaster Recovery feature allows the CPU to be replaced with the existing configuration. After replacing the CPU, the node reboots and comes up by restoring the software and configuration files from the chassis SSD without traffic loss.

CPU Replacement Considerations

You must consider the following points for CPU replacement.

- When the CPU is removed from the chassis, NCS 1010 chassis runs in headless mode which is non-traffic impacting.
- When the CPU is replaced with another CPU having the same software and RPMs as in the chassis SSD, the configuration is restored from the chassis SSD.
- When the CPU is replaced with another CPU having different software and RPMs as in the chassis SSD, the Disaster recovery process starts. In this case, the node boots with the software from the chassis SSD and the configuration is also restored from the chassis SSD.

Health Check of Backup ISO Image

The Health Check feature ensures error-free booting of NCS 1010 chassis during disaster recovery operations. NCS 1010 has a partition for disaster recovery where the backup ISO image is stored. The backup ISO image is stored in the chassis SSD.

The chassis SSD content is audited against the running software by the install process in the background every 12 hours to detect corruption. If the ISO image is corrupted, the software will recover it by copying from the backup location. If the software fails to synchronize with the chassis SSD, then the **Disaster Recovery ISO Image Corruption** alarm is raised. See the *Troubleshooting Guide for Cisco NCS 1010* to clear the alarm.



CHAPTER 4

Perform Preliminary Checks

After successfully logging into the console, you must perform some preliminary checks to verify the default setup. If any setup issue is detected, take corrective action before making further configurations.



Note The output of the examples in the procedures is not from the latest software release. The output will change for any explicit references to the current release.

- [Verify Status of Hardware Components, on page 37](#)
- [Verify Inventory, on page 38](#)
- [Verify Software Version, on page 39](#)
- [Verify Firmware Version, on page 40](#)
- [Verify Management Interface Status, on page 42](#)
- [Verify Alarms, on page 43](#)
- [Verify Environmental Parameters, on page 44](#)
- [Verify Context, on page 49](#)
- [Verify Core Files, on page 50](#)
- [Verify Memory Information, on page 50](#)

Verify Status of Hardware Components

To verify the status of all the hardware components installed on NCS 1010, perform the following procedure.

Before you begin

Ensure that all the required hardware components are installed on NCS 1010. For installation details, see *Cisco Network Convergence System 1010 Hardware Installation Guide*.

show platform

When you execute this command, the status of Cisco IOS XR is displayed.

Example:

```
RP/0/RP0/CPU0:ios#show platform
Wed Apr 27 08:43:40.130 UTC
Node                Type                State                Config state
```

```

-----
0/RP0/CPU0      NCS1010-CNTRLR-K9(Active) IOS XR RUN      NSHUT,NMON
0/PM0           NCS1010-AC-PSU           OFFLINE       NSHUT,NMON
0/PM1           NCS1010-AC-PSU           OPERATIONAL   NSHUT,NMON
0/FT0           NCS1010-FAN              OPERATIONAL   NSHUT,NMON
0/FT1           NCS1010-FAN              OPERATIONAL   NSHUT,NMON
0/0/NXR0        NCS1K-OLT-C              OPERATIONAL   NSHUT,NMON
0/1             NCS1K-BRK-SA             OPERATIONAL   NSHUT,NMON
0/1/0           NCS1K-BRK-8              OPERATIONAL   NSHUT,NMON
0/1/1           NCS1K-BRK-8              OPERATIONAL   NSHUT,NMON
0/1/2           NCS1K-BRK-24             OPERATIONAL   NSHUT,NMON
0/1/3           NCS1K-BRK-24             OPERATIONAL   NSHUT,NMON
0/2             NCS1K-MD-32E-C           OPERATIONAL   NSHUT,NMON
0/3             NCS1K-MD-32O-C           OPERATIONAL   NSHUT,NMON

```

Verify that all the components of NCS 1010 are displayed in output. The state must be in the OPERATIONAL state. The various states are:

- OPERATIONAL—Node is operating normally and is fully functional.
- POWERED_ON—Power is on and the node is booting up.
- FAILED—Node is powered on but has encountered an internal failure.
- PRESENT—Node is in intermediate state in the boot sequence.
- POWERED_OFF—Power is off and the node cannot be accessed.
- IOS XR RUN—Node is running IOS XR.
- OFFLINE—Input power is not connected to the power modules.

Verify Inventory

The **show inventory** command displays details of the hardware inventory of NCS 1010.

To verify the inventory information for all the physical entities, perform the following procedure.

show inventory

Displays the details of the physical entities of NCS 1010 along with the details of SFPs.

Example:

```

RP/0/RP0/CPU0:ios#show inventory
Wed Apr 27 08:43:44.222 UTC

NAME: "Rack 0", DESCR: "NCS1010 - Shelf Assembly"
PID: NCS1010-SA      , VID: V00, SN: FCB2504B0X4

NAME: "0/RP0/CPU0", DESCR: "Network Convergence System 1010 Controller"
PID: NCS1010-CNTRLR-K9  , VID: V00, SN: FCB2506B0NX

NAME: "0/1", DESCR: "NCS 1000 shelf for 4 passive modules"
PID: NCS1K-BRK-SA      , VID: V00 , SN: FCB2534B0GR

NAME: "0/1/0", DESCR: "NCS 1000 MTP/MPO to 8 port passive breakout module"

```

```

PID: NCS1K-BRK-8      , VID: V00 , SN: MPM25401005

NAME: "0/1/1", DESCR: "NCS 1000 MTP/MPO to 8 port passive breakout module"
PID: NCS1K-BRK-8      , VID: V00 , SN: MPM25401003

NAME: "0/1/2", DESCR: "NCS 1000 MTP/MPO to 24 colorless chs passive breakout module"
PID: NCS1K-BRK-24    , VID: V00 , SN: MPM25141004

NAME: "0/1/3", DESCR: "NCS 1000 MTP/MPO to 24 colorless chs passive breakout module"
PID: NCS1K-BRK-24    , VID: V00 , SN: MPM25371005

NAME: "0/2", DESCR: "NCS 1000 32 chs Even Mux/Demux Patch Panel - 150GHz - C-band"
PID: NCS1K-MD-32E-C   , VID: V00 , SN: ACW2529YE13

NAME: "0/3", DESCR: "NCS 1000 32 chs Odd Mux/Demux Patch Panel - 150GHz - C-band"
PID: NCS1K-MD-32O-C   , VID: V00 , SN: ACW2529YA13

NAME: "0/FT0", DESCR: "NCS1010 - Shelf Fan"
PID: NCS1010-FAN      , VID: V00, SN: FCB2504B0W3

NAME: "0/FT1", DESCR: "NCS1010 - Shelf Fan"
PID: NCS1010-FAN      , VID: V00, SN: FCB2504B0U8

NAME: "0/PM0", DESCR: "NCS 1010 - AC Power Supply Unit"
PID: NCS1010-AC-PSU   , VID: V00, SN: APS244700D0

NAME: "0/PM1", DESCR: "NCS 1010 - AC Power Supply Unit"
PID: NCS1010-AC-PSU   , VID: V00, SN: APS244700BY

```

Verify Software Version

NCS 1010 is shipped with the Cisco IOS XR software preinstalled. Verify that the latest version of the software is installed. If a newer version is available, perform a [Upgrade Software, on page 51](#). This software upgrade installs the newer version of the software and provide the latest feature set on NCS 1010.

To verify the version of Cisco IOS XR Software running on NCS 1010, perform the following procedure.

show version

Displays the software version and details such as system uptime.

Example:

```

RP/0/RP0/CPU0:ios#show version
Thu Jul 28 09:49:34.374 UTC
Cisco IOS XR Software, Version 7.7.1 LNT
Copyright (c) 2013-2022 by Cisco Systems, Inc.

Build Information:
Build By      : ingunawa
Build On      : Mon Jul 25 06:07:25 UTC 2022
Build Host    : iox-lnx-109
Workspace     : /auto/srcarchive12/prod/7.7.1/ncs1010/ws
Version       : 7.7.1
Label        : 7.7.1

cisco NCS1010 (C3758 @ 2.20GHz)
cisco NCS1010-SA (C3758 @ 2.20GHz) processor with 32GB of memory

```

```
DT_smart_lic1 uptime is 10 minutes
NCS 1010 - Chassis
```

Verify the software version to determine whether system upgrade is required. If the upgrade is required, see [Upgrade Software, on page 51](#).

Verify Firmware Version

The firmware version on various hardware components of NCS 1010 must be compatible with the installed Cisco IOS XR release. Incompatibility may cause NCS 1010 to malfunction.

To verify the firmware version, perform the following procedure.

Step 1 show hw-module fpd

Displays the firmware information of various hardware components of NCS 1010.

Example:

```
RP/0/RP0/CPU0:ios# show hw-module fpd
```

```
Wed Jun 29 08:50:21.057 UTC
```

```
Auto-upgrade:Disabled
```

Location	Card type	HWver	FPD device	ATR	Status	FPD Versions		Reload Loc
						Running	Programd	
0/RP0/CPU0	NCS1010-CNTRLR-K9	1.0	ADMConfig		CURRENT	3.40	3.40	NOT REQ
0/RP0/CPU0	NCS1010-CNTRLR-K9	1.0	BIOS	S	CURRENT	4.10	4.10	0/RP0
0/RP0/CPU0	NCS1010-CNTRLR-K9	1.0	BIOS-Golden	BS	CURRENT		4.10	0/RP0
0/RP0/CPU0	NCS1010-CNTRLR-K9	1.0	CpuFpga	S	CURRENT	1.02	1.02	0/RP0
0/RP0/CPU0	NCS1010-CNTRLR-K9	1.0	CpuFpgaGolden	BS	CURRENT		1.01	0/RP0
0/RP0/CPU0	NCS1010-CNTRLR-K9	1.0	SsdIntelS4510	S	CURRENT	11.32	11.32	0/RP0
0/RP0/CPU0	NCS1010-CNTRLR-K9	1.0	TamFw	S	CURRENT	6.13	6.13	0/RP0
0/RP0/CPU0	NCS1010-CNTRLR-K9	1.0	TamFwGolden	BS	CURRENT		6.11	0/RP0
0/PM0	NCS1010-AC-PSU	0.0	AP-PrimCU		CURRENT	1.03	1.03	NOT REQ
0/PM0	NCS1010-AC-PSU	0.0	AP-SecMCU		CURRENT	2.01	2.01	NOT REQ
0/PM1	NCS1010-AC-PSU	0.0	AP-PrimCU		CURRENT	1.03	1.03	NOT REQ
0/PM1	NCS1010-AC-PSU	0.0	AP-SecMCU		CURRENT	2.01	2.01	NOT REQ
0/0/NXR0	NCS1K-ILA-C	1.0	ILA	S	CURRENT	1.00	1.00	NOT REQ
0/Rack	NCS1010-SA	1.0	EITU-ADMConfig		CURRENT	2.10	2.10	NOT REQ
0/Rack	NCS1010-SA	1.0	IoFpga	S	CURRENT	1.04	1.04	NOT REQ
0/Rack	NCS1010-SA	1.0	IoFpgaGolden	BS	CURRENT		1.01	NOT REQ
0/Rack	NCS1010-SA	1.0	SsdIntelS4510	S	CURRENT	11.32	11.32	0/Rack

Step 2 show fpd package

Displays the FPD image version available with this software release for each hardware component.

Example:

```
RP/0/RP0/CPU0:ios#show fpd package
```

```
Wed Jun 29 08:50:21.057 UTC
```

```
=====
Field Programmable Device Package
```

Card Type	FPD Description	Req Reload	SW Ver	Min Req SW Ver	Min Req Board Ver
NCS1010-AC-PSU	AP-PrimMCU	NO	1.03	1.03	0.0
	AP-SecMCU	NO	2.01	2.01	0.0
NCS1010-CNTLR-K9	ADMConfig	NO	2.30	2.30	0.0
	ADMConfig	NO	2.30	2.30	0.0
	ADMConfig	NO	3.40	3.30	1.0
	BIOS	YES	4.10	4.10	0.0
	BIOS	YES	4.10	4.10	0.0
	BIOS-Golden	YES	4.10	4.10	0.0
	BIOS-Golden	YES	4.10	4.10	0.0
	CpuFpga	YES	1.02	1.02	0.0
	CpuFpga	YES	1.02	1.02	0.0
	CpuFpgaGolden	YES	1.01	1.01	0.0
	CpuFpgaGolden	YES	1.01	1.01	0.0
	SsdIntelS4510	YES	11.32	11.32	0.0
	SsdIntelS4510	YES	11.32	11.32	0.0
	SsdMicron5300	YES	0.01	0.01	0.0
	SsdMicron5300	YES	0.01	0.01	0.0
	SsdSmartModular	YES	13.06	13.06	0.0
	SsdSmartModular	YES	13.06	13.06	0.0
TamFw	YES	6.13	6.13	0.0	
TamFw	YES	6.13	6.13	0.0	
TamFwGolden	YES	6.11	6.11	0.0	
TamFwGolden	YES	6.11	6.11	0.0	
NCS1010-SA	EITU-ADMConfig	NO	1.04	1.04	0.0
	EITU-ADMConfig	NO	2.10	2.10	1.0
	EITU-ADMConfig	NO	1.04	1.04	0.0
	EITU-ADMConfig	NO	2.10	2.10	1.0
	IoFpga	NO	1.04	1.04	0.0
	IoFpga	NO	1.04	1.04	0.0
	IoFpgaGolden	NO	1.01	1.01	0.0
	IoFpgaGolden	NO	1.01	1.01	0.0
	SsdIntelS4510	YES	11.32	11.32	0.0
	SsdIntelS4510	YES	11.32	11.32	0.0
	SsdMicron5300	YES	0.01	0.01	0.0
	SsdMicron5300	YES	0.01	0.01	0.0
	SsdSmartModular	YES	13.06	13.06	0.0
SsdSmartModular	YES	13.06	13.06	0.0	
NCS1K-ILA-2R-C	ILA	NO	1.00	1.00	0.1
	ILA	NO	0.23	0.23	99.1
	Raman-1	NO	1.00	1.00	0.1
	Raman-1	NO	0.23	0.23	99.1
	Raman-2	NO	1.00	1.00	0.1
	Raman-2	NO	0.23	0.23	99.1
NCS1K-ILA-C	ILA	NO	1.00	1.00	0.1
	ILA	NO	0.23	0.23	99.1
NCS1K-ILA-R-C	ILA	NO	1.00	1.00	0.1
	ILA	NO	0.23	0.23	99.1
	Raman-1	NO	1.00	1.00	0.1
	Raman-1	NO	0.23	0.23	99.1
NCS1K-OLT-C	OLT	NO	1.00	1.00	0.1
	OLT	NO	0.23	0.23	99.1
NCS1K-OLT-R-C	OLT	NO	1.00	1.00	0.1

OLT	NO	0.23	0.23	99.1
Raman-1	NO	1.00	1.00	0.1
Raman-1	NO	0.23	0.23	99.1

Verify Management Interface Status

To verify the management interface status, perform the following procedure.

Step 1 show interfaces MgmtEth 0/RP0/CPU0/0

Displays the management interface configuration.

Example:

```
RP/0/RP0/CPU0:ios#show interfaces MgmtEth 0/RP0/CPU0/0
Wed May 25 11:49:18.118 UTC
MgmtEth0/RP0/CPU0/0 is up, line protocol is up
  Interface state transitions: 1
  Hardware is Management Ethernet, address is 38fd.f866.0964 (bia 38fd.f866.0964)
  Internet address is 10.33.0.61/16
  MTU 1514 bytes, BW 1000000 Kbit (Max: 1000000 Kbit)
    reliability 255/255, txload 0/255, rxload 0/255
  Encapsulation ARPA,
  Full-duplex, 1000Mb/s, CX, link type is autonegotiation
  loopback not set,
  Last link flapped 15:05:21
  ARP type ARPA, ARP timeout 04:00:00
  Last input never, output 00:00:00
  Last clearing of "show interface" counters never
  5 minute input rate 0 bits/sec, 0 packets/sec
  5 minute output rate 0 bits/sec, 0 packets/sec
    53138 packets input, 6636701 bytes, 0 total input drops
    0 drops for unrecognized upper-level protocol
    Received 12145 broadcast packets, 40082 multicast packets
      0 runts, 0 giants, 0 throttles, 0 parity
    0 input errors, 0 CRC, 0 frame, 0 overrun, 0 ignored, 0 abort
    217288 packets output, 60964220 bytes, 0 total output drops
    Output 1 broadcast packets, 15 multicast packets
    0 output errors, 0 underruns, 0 applique, 0 resets
    0 output buffer failures, 0 output buffers swapped out
    1 carrier transitions
```

Step 2 show interfaces summary and show interfaces brief

Verifies the management interface status.

Example:

```
RP/0/RP0/CPU0:ios#show interfaces summary
Wed May 25 11:50:02.558 UTC
Interface Type          Total    UP      Down    Admin Down
-----
ALL TYPES                9        5        0         4
-----
IFT_ETHERNET            1         1         0         0
IFT_LOOPBACK            2         2         0         0
IFT_ETHERNET            3         1         0         2
IFT_NULL                 1         1         0         0
```



```
IFT_PTP_ETHERNET      2      0      0      2
```

Example:

```
RP/0/RP0/CPU0:ios#show interfaces brief
Wed May 25 11:50:28.438 UTC
```

Intf Name	Intf State	LineP State	Encap Type	MTU (byte)	BW (Kbps)
Lo0	up	up	Loopback	1500	0
Lo3	up	up	Loopback	1500	0
Nu0	up	up	Null	1500	0
Gi0/0/0/0	up	up	ARPA	1514	1000000
Mg0/RP0/CPU0/0	up	up	ARPA	1514	1000000
Mg0/RP0/CPU0/1	admin-down	admin-down	ARPA	1514	1000000
Mg0/RP0/CPU0/2	admin-down	admin-down	ARPA	1514	1000000
PT0/RP0/CPU0/0	admin-down	admin-down	ARPA	1514	1000000
PT0/RP0/CPU0/1	admin-down	admin-down	ARPA	1514	1000000

Example:

```
RP/0/RP0/CPU0:ios#show ipv4 interfaces brief
Tue Jul 12 07:32:42.390 UTC
```

Interface	IP-Address	Status	Protocol	Vrf-Name
Loopback0	10.3.3.21	Up	Up	default
Loopback3	10.1.1.2	Up	Up	default
GigabitEthernet0/0/0/0	10.7.1.20	Up	Up	default
MgmtEth0/RP0/CPU0/0	10.4.33.63	Up	Up	default
PTP0/RP0/CPU0/0	unassigned	Shutdown	Down	default
MgmtEth0/RP0/CPU0/1	unassigned	Down	Down	default
PTP0/RP0/CPU0/1	unassigned	Shutdown	Down	default
MgmtEth0/RP0/CPU0/2	unassigned	Down	Down	default

Verify Alarms

You can view the alarm information using the **show alarms** command.

```
show alarms [ brief [ card | rack | system ] [ location location ] [ active | history ] | detail [ card | rack | system ] [ location location ] [ active | clients | history | stats ] ]
```

Displays alarms in brief or detail.

Example:

```
RP/0/RP0/CPU0:ios#show alarms brief system active
```

```
Thu Apr 28 06:16:50.524 UTC
```

```
-----
Active Alarms
-----
```

Location	Severity	Group	Set Time	Description
0/RP0/CPU0	Major	Ethernet	04/28/2022 06:03:39 UTC	RP-SW: SPI flash config is incorrect

Verify Environmental Parameters

```

0/PM0          Major      Environ      04/28/2022 06:03:50 UTC    Power Module Error (PM_VIN_VOLT_OOR)
0/PM0          Major      Environ      04/28/2022 06:03:50 UTC    Power Module Output Disabled
(PM_OUTPUT_DISABLED)
0              Major      Environ      04/28/2022 06:03:50 UTC    Power Group redundancy lost
0/PM0          Major      FPD_Infra    04/28/2022 06:04:08 UTC    One Or More FPDs Need Upgrade Or Not In
Current State
0/PM1          Major      FPD_Infra    04/28/2022 06:04:09 UTC    One Or More FPDs Need Upgrade Or Not In
Current State
0/0            Minor      Environ      04/28/2022 06:04:10 UTC    ILAC_CT_1: Invalid sensor read error.
0/0            Minor      Environ      04/28/2022 06:04:10 UTC    ILAC_CT_2: Invalid sensor read error.
0/0            Minor      Environ      04/28/2022 06:04:10 UTC    ILAC_CT_3: Invalid sensor read error.
0/0            Minor      Environ      04/28/2022 06:04:10 UTC    ILAC_CT_4: Invalid sensor read error.
0/0            Major      Controller    04/28/2022 06:05:12 UTC    Osc0/0/0/0 - Provisioning Failed
0/0            Major      Controller    04/28/2022 06:05:12 UTC    Osc0/0/0/2 - Provisioning Failed
0/0            Major      Controller    04/28/2022 06:05:12 UTC    Ots0/0/0/0 - Provisioning Failed
0/0            Major      Controller    04/28/2022 06:05:12 UTC    Ots0/0/0/2 - Provisioning Failed

```

Note In the maintenance mode, all the alarms are moved from active to suppressed and the **show alarms** command does not display the alarms details.

Verify Environmental Parameters

The **show environment** command displays the environmental parameters of NCS 1010.

To verify that the environmental parameters are as expected, perform the following procedure.

```

show environment [ alarm-contact | all | altitude | current | fan | humidity | power | voltages [
location | location ] | temperature [ location | location ] ]

```

Displays the environmental parameters of NCS 1010.

Example:

The following example shows a sample output of the **show environment** command with the **fan** keyword.

```

RP/0/RP0/CPU0:ios#show environment fan
Thu May 26 04:15:37.765 UTC

```

```

=====
Location          FRU Type                               Fan speed (rpm)
                FAN_0    FAN_1    FAN_2
-----
0/PM0             NCS1010-AC-PSU                        5368
0/PM1             NCS1010-AC-PSU                        5336
0/FT0             NCS1010-FAN                            10020    10020    10020
0/FT1             NCS1010-FAN                            10020    10020    9960
=====

```

The following example shows a sample output of the **show environment** command with the **temperatures** keyword for *0/RP0 location*.

```

RP/0/RP0/CPU0:ios#show environment temperature location 0/RP0

```

```

Thu May 26 04:16:39.832 UTC

```

```

=====
Location TEMPERATURE          Value  Crit  Major  Minor  Minor  Major  Crit
          Sensor              (deg C) (Lo)  (Lo)  (Lo)  (Hi)  (Hi)  (Hi)
-----
0/RP0/CPU0

```

```

RP_TEMP_PCB                30      -10      -5       0       70       75       80
RP_TEMP_HOT_SPOT           33      -10      -5       0       70       75       80
RP_TEMP_LTM4638            49      -10      -5       0       80       85       90
RP_TEMP_LTM4644_0         36      -10      -5       0       80       85       90
RP_TEMP_LTM4644_1         39      -10      -5       0       80       85       90
RP_JMAC_1V0_VCCP_TMON     33      -10      -5       0       80       85       90
RP_JMAC_1V0_VNN_TMON     33      -10      -5       0       80       85       90
RP_JMAC_1V0_VCC_RAM_TMON  32      -10      -5       0       80       85       90
RP_JMAC_1V2_DDR_VDDQ_TMON 33      -10      -5       0       80       85       90

```

The following example shows a sample output of the **show environment** command with the **temperatures** keyword for **0/0/NXR0** location.

```
RP/0/RP0/CPU0:ios#show environment temperature location 0/0/NXR0
```

```
Thu May 26 04:16:39.832 UTC
```

```

=====
Location  TEMPERATURE                               Value  Crit   Major  Minor  Minor  Major  Crit
Sensor    (deg C)  (Lo)   (Lo)   (Lo)   (Hi)   (Hi)   (Hi)
-----
0/0/NXR0
OLTC_LT_P0_iEDFA0          24      18     19     20     30     31     32
OLTC_LT_P0_iEDFA1          25      18     19     20     30     31     32
OLTC_LT_P0_iEDFA2          24      18     19     20     30     31     32
OLTC_LT_P2_iEDFA0          25      18     19     20     30     31     32
OLTC_LT_P3_iEDFA0          25      18     19     20     30     31     32
OLTC_LT_P0_eEDFA0          24      18     19     20     30     31     32
OLTC_CT_1                   32     -10     -7     -5     75     77     80
OLTC_LT_P0_eEDFA1          24      18     19     20     30     31     32
OLTC_CT_2                   27     -10     -7     -5     70     73     75
OLTC_CT_3                   30     -10     -7     -5     70     73     75
OLTC_CT_4                   30     -10     -7     -5     70     73     75
OLTC_FT_P0_iEDFA0          60      55     57     58     62     64     65
OLTC_FT_P2_iEDFA0          60      55     57     58     62     64     65
OLTC_FT_P3_iEDFA0          60      55     57     58     62     64     65
OLTC_FT_P0_eEDFA0          60      55     57     58     62     64     65
=====

```

The following example shows a sample output of the **show environment** command with the **power** keyword.

```
RP/0/RP0/CPU0:ios#show environment power
```

```
Thu May 26 04:17:55.592 UTC
```

```
CHASSIS LEVEL POWER INFO: 0
```

```

=====
Total output power capacity (Group 0 + Group 1) : 1050W + 1050W
Total output power required : 700W
Total power input : 228W
Total power output : 140W

```

```
Power Group 0:
```

```

=====
Power   Supply   -----Input-----  -----Output---   Status
Module  Type      Volts   Amps   Volts   Amps
=====
0/PM0   NCS1010-AC-PSU  228.5   0.5   12.1   5.6   OK

```

```
Total of Group 0: 114W/0.5A 67W/5.6A
```

```
Power Group 1:
```

```

=====
Power   Supply   -----Input-----  -----Output---   Status
Module  Type      Volts   Amps   Volts   Amps
=====
0/PM1   NCS1010-AC-PSU  228.5   0.5   12.1   6.1   OK

```

```
Total of Group 1: 114W/0.5A 73W/6.1A
```

```

=====
Location      Card Type                Power      Power      Status
                Allocated  Used
                Watts      Watts
=====
0/RP0/CPU0    NCS1010-CNTRLR-K9        90          14         ON
0/FT0         NCS1010-FAN              110         17         ON
0/FT1         NCS1010-FAN              110         15         ON
0/0/NXR0     NCS1K-OLT-C              350         61         ON
0/Rack       NCS1010-SA                40          19         ON
=====

```

The following example shows a sample output of the **show environment** command with the **voltages** keyword.

```
RP/0/RP0/CPU0:ios#show environment voltage location 0/RP0
Thu May 26 04:19:16.636 UTC
```

```

=====
Location  VOLTAGE                Value      Crit      Minor      Minor      Crit
          Sensor                (mV)      (Lo)      (Lo)      (Hi)      (Hi)
=====
0/RP0/CPU0
RP_ADM1266_12V0          12094     10800     11280     12720     13200
RP_ADM1266_1V8_CPU       1806      1670      1750      1850      1930
RP_ADM1266_1V24_VCCREF   1238      1150      1200      1280      1330
RP_ADM1266_1V05_CPU      1047       980      1020      1080      1120
RP_ADM1266_1V2_DDR_VDDQ  1204      1120      1160      1240      1280
RP_ADM1266_1V0_VCC_RAM    988        650       700      1250      1300
RP_ADM1266_1V0_VNN        869        550       600      1250      1300
RP_ADM1266_1V0_VCCP      1018       450       500      1250      1300
RP_ADM1266_0V6_DDR_VTT    599        560       580       620       640
RP_ADM1266_3V3_STAND_BY   3301      3070      3200      3400      3530
RP_ADM1266_5V0           5004      4650      4850      5150      5350
RP_ADM1266_3V3           3325      3070      3200      3400      3530
RP_ADM1266_2V5_PLL       2489      2330      2430      2580      2680
RP_ADM1266_2V5_FPGA       2502      2330      2430      2580      2680
RP_ADM1266_1V2_FPGA       1202      1120      1160      1240      1280
RP_ADM1266_3V3_CPU       3332      3070      3200      3400      3530
RP_ADM1266_2V5_CPU       2498      2330      2430      2580      2680
=====

```

The following example shows a sample output of the **show environment** command with the **current** keyword.

```
RP/0/RP0/CPU0:P2C_DT_02#show environment current
Tue Jul 5 08:36:22.132 UTC
```

```

=====
Location  CURRENT                Value
          Sensor                (mA)
=====
0/RP0/CPU0
RP_CURRMON_LTM4638          395
RP_CURRMON_LTM4644_0        179
RP_CURRMON_LTM4644_1        307
RP_JMAC_1V0_VCCP_IMON       187
RP_JMAC_1V0_VNN_IMON        62
RP_JMAC_1V0_VCC_RAM_IMON     0
RP_JMAC_1V2_DDR_VDDQ_IMON    187
0/Rack
SA_ADM1275_12V_MOD0_IMON    4154
SA_ADM1275_12V_MOD1_IMON     43
SA_ADM1275_12V_MOD2_IMON     18
SA_ADM1275_12V_FAN0_IMON   1356
=====

```

```
SA_ADM1275_12V_FAN1_IMON      1517
SA_INA230_5V0_IMON            129
SA_INA230_3V3_IMON            2998
SA_INA230_1V0_XGE_CORE_IMON   2464
SA_INA230_1V0_FPGA_CORE_IMON  787
SA_ADM1275_12V_SA_IMON        1668
SA_ADM1275_12V_CPU_IMON       1147
```

The following example shows a sample output of the **show environment** command with the **altitude** keyword.

```
RP/0/RP0/CPU0:P2C_DT_02#show environment altitude
Tue Jul  5 08:36:51.710 UTC
```

```
=====
Location      Altitude Value (Meters)      Source
-----
0              760                          sensor
```

The following example shows a sample output of the **show environment** command with the **all** keyword.

```
RP/0/RP0/CPU0:P2C_DT_02#show environment all
```

```
Tue Jul  5 08:37:28.412 UTC
```

```
=====
Location      TEMPERATURE                      Value      Crit      Major      Minor      Minor      Major      Crit
              Sensor                            (deg C)   (Lo)      (Lo)      (Lo)      (Hi)      (Hi)      (Hi)
-----
0/RP0/CPU0
  RP_TEMP_PCB                29        -10       -5         0         70        75        80
  RP_TEMP_HOT_SPOT           32        -10       -5         0         70        75        80
  RP_TEMP_LTM4638            45        -10       -5         0         80        85        90
  RP_TEMP_LTM4644_0          35        -10       -5         0         80        85        90
  RP_TEMP_LTM4644_1          38        -10       -5         0         80        85        90
  RP_JMAC_1V0_VCCP_TMON      30        -10       -5         0         80        85        90
  RP_JMAC_1V0_VNN_TMON      29        -10       -5         0         80        85        90
  RP_JMAC_1V0_VCC_RAM_TMON   30        -10       -5         0         80        85        90
  RP_JMAC_1V2_DDR_VDDQ_TMON  31        -10       -5         0         80        85        90
0/PM0
  Ambient Temp                29        -10       -5         0         55        60        65
  Secondary HotSpot Temp      50        -10       -5         0         85        90        95
  Primary HotSpot Temp       41        -10       -5         0         65        70        75
0/0/NXR0
  ILAC_LT_P0_eEDFA0           25         18        19        20        30        31        32
  ILAC_LT_P0_eEDFA1           25         18        19        20        30        31        32
  ILAC_LT_P0_eEDFA2           25         18        19        20        30        31        32
  ILAC_LT_P2_eEDFA0           25         18        19        20        30        31        32
  ILAC_LT_P2_eEDFA1           25         18        19        20        30        31        32
  ILAC_LT_P2_eEDFA2           25         18        19        20        30        31        32
  ILAC_CT_1                   29        -10       -7         -5        75        77        80
  ILAC_CT_2                   26        -10       -7         -5        70        73        75
  ILAC_CT_3                   28        -10       -7         -5        70        73        75
  ILAC_CT_4                   28        -10       -7         -5        70        73        75
  ILAC_FT_P0_eEDFA0           59         55        57        58        62        64        65
  ILAC_FT_P0_eEDFA1           59         55        57        58        62        64        65
0/Rack
  SA_TEMP_AIR_INLET0           25        -10       -5         0         45        55        60
  SA_TEMP_AIR_INLET1           25        -10       -5         0         45        55        60
  SA_TEMP_AIR_EXAUST0          27        -10       -5         0         75        85        90
  SA_TEMP_AIR_EXAUST1          26        -10       -5         0         75        85        90
  SA_TEMP_PCB_HOT_SPOT0        28        -10       -5         0         80        85        90
  SA_TEMP_PCB_HOT_SPOT1        32        -10       -5         0         80        85        90
  SA_TEMP_PCB_HOT_SPOT2        28        -10       -5         0         80        85        90
  SA_TEMP_PCB_HOT_SPOT3        30        -10       -5         0         80        85        90
```

```
=====
Location      VOLTAGE                          Value      Crit      Minor      Minor      Crit
              Sensor                            (mV)      (Lo)      (Lo)      (Hi)      (Hi)
-----
0/RP0/CPU0
  RP_ADM1266_12V0            12094     10800     11280     12720     13200
```

Verify Environmental Parameters

	RP_ADM1266_1V8_CPU	1801	1670	1750	1850	1930
	RP_ADM1266_1V24_VCCREF	1238	1150	1200	1280	1330
	RP_ADM1266_1V05_CPU	1054	980	1020	1080	1120
	RP_ADM1266_1V2_DDR_VDDQ	1207	1120	1160	1240	1280
	RP_ADM1266_1V0_VCC_RAM	988	650	700	1250	1300
	RP_ADM1266_1V0_VNN	858	550	600	1250	1300
	RP_ADM1266_1V0_VCCP	1008	450	500	1250	1300
	RP_ADM1266_0V6_DDR_VTT	603	560	580	620	640
	RP_ADM1266_3V3_STAND_BY	3310	3070	3200	3400	3530
	RP_ADM1266_5V0	4996	4650	4850	5150	5350
	RP_ADM1266_3V3	3328	3070	3200	3400	3530
	RP_ADM1266_2V5_PLL	2489	2330	2430	2580	2680
	RP_ADM1266_2V5_FPGA	2500	2330	2430	2580	2680
	RP_ADM1266_1V2_FPGA	1197	1120	1160	1240	1280
	RP_ADM1266_3V3_CPU	3332	3070	3200	3400	3530
	RP_ADM1266_2V5_CPU	2502	2330	2430	2580	2680
0/Rack	SA_ADM1266_12V_BUS_EITU	12057	10800	11280	12720	13200
	SA_ADM1266_5V0	5022	4650	4800	5200	5350
	SA_ADM1266_1V8_ZARLINK_DPLL	1806	1670	1730	1870	1930
	SA_ADM1266_1V0_PHY	1009	930	960	1040	1070
	SA_ADM1266_1V0_ALDRIN_CORE	982	910	930	1070	1090
	SA_ADM1266_1V0_ALDRIN_SERDES	1007	930	960	1040	1070
	SA_ADM1266_1V0_FPGA	1008	930	960	1040	1070
	SA_ADM1266_1V2_FPGA	1205	1120	1150	1250	1280
	SA_ADM1266_1V8	1804	1670	1730	1870	1930
	SA_ADM1266_2V5	2505	2330	2400	2600	2680
	SA_ADM1266_3V3	3323	3070	3170	3430	3530
	SA_ADM1275_12V_SA_BP	12058	10800	11280	12720	13200
	SA_ADM1275_12V_CPU_BP	12032	10800	11280	12720	13200
	SA_ADM1275_12V_MOD0_BP	12063	10800	11280	12720	13200
	SA_ADM1275_12V_MOD1_BP	12048	10800	11280	12720	13200
	SA_ADM1275_12V_MOD2_BP	12027	10800	11280	12720	13200
	SA_ADM1275_12V_FAN0_BP	12032	10800	11280	12720	13200
	SA_ADM1275_12V_FAN1_BP	12042	10800	11280	12720	13200

```

=====
Location  CURRENT                               Value
          Sensor                               (mA)
-----

```

0/RP0/CPU0

```

RP_CURRMON_LTM4638                395
RP_CURRMON_LTM4644_0              179
RP_CURRMON_LTM4644_1              307
RP_JMAC_1V0_VCCP_IMON             125
RP_JMAC_1V0_VNN_IMON              62
RP_JMAC_1V0_VCC_RAM_IMON          0
RP_JMAC_1V2_DDR_VDDQ_IMON        156

```

0/Rack

```

SA_ADM1275_12V_MOD0_IMON          3412
SA_ADM1275_12V_MOD1_IMON           30
SA_ADM1275_12V_MOD2_IMON           43
SA_ADM1275_12V_FAN0_IMON          1418
SA_ADM1275_12V_FAN1_IMON          1394
SA_INA230_5V0_IMON                129
SA_INA230_3V3_IMON                3020
SA_INA230_1V0_XGE_CORE_IMON       2464
SA_INA230_1V0_FPGA_CORE_IMON       787
SA_ADM1275_12V_SA_IMON            1640
SA_ADM1275_12V_CPU_IMON           1157

```

```

=====
Location  FRU Type                               Fan speed (rpm)
          FRU Type                               FAN_0   FAN_1   FAN_2
-----

```

```

0/PM0      NCS1010-AC-PSU      5424
0/FT0      NCS1010-FAN          9960    9960    9960
0/FT1      NCS1010-FAN          10020   10020   10020
=====
Location    Altitude Value (Meters)    Source
-----
0           760                          sensor

=====
CHASSIS LEVEL POWER INFO: 0
=====
Total output power capacity (Group 0 + Group 1) : 1050W + 0W
Total output power required                      : 700W
Total power input                               : 159W
Total power output                              : 129W

Power Group 0:
=====
Power      Supply      -----Input-----  -----Output---    Status
Module     Type                Volts    Amps    Volts    Amps
-----
0/PM1      NCS1010-AC-PSU    0.0      0.0     0.0      0.0     OFFLINE

Total of Group 0:                0W/0.0A          0W/0.0A

Power Group 1:
=====
Power      Supply      -----Input-----  -----Output---    Status
Module     Type                Volts    Amps    Volts    Amps
-----
0/PM0      NCS1010-AC-PSU    228.5    0.7     12.1     10.7    OK

Total of Group 1:                159W/0.7A        129W/10.7A

=====
Location    Card Type                Power      Power      Status
                Allocated    Used
                Watts       Watts
-----
0/RP0/CPU0  NCS1010-CNTRLR-K9      90         14         ON
0/FT0       NCS1010-FAN            110        17         ON
0/FT1       NCS1010-FAN            110        16         ON
0/0/NXR0    NCS1K-ILA-C            350        54         ON
0/Rack      NCS1010-SA              40         19         ON

```

Environment parameter anomalies are logged in the syslog. As a result, if an environment parameter that is displayed in the **show environment** command output is not as expected, check the syslog using the **show logging** and **show alarms brief system active** command. The syslog provides details on any logged problems.

Verify Context

The **show context** command displays core dump context information of NCS 1010. Core dump is a result of abnormal exit of any process running in the system.

show context

Displays the core dump context information of NCS 1010.

Example:

```
RP/0/RP0/CPU0:ios# show context
Mon Sep 27 17:21:59.219 UTC
```

```
node: node0_RP0_CPU0
-----
```

```
No context
```

The command output is empty during system upgrade.

Verify Core Files

Use the **run** command to go to the hard disk location and check for the core dumps of NCS 1010.

run**Example:**

```
RP/0/RP0/CPU0:ios# run
Mon Sep 27 17:29:11.163 UTC
[xr-vm_node0_RP0_CPU0:~]$cd /misc/disk1/
[xr-vm_node0_RP0_CPU0:/misc/disk1]$ls -lrt *.tgz
```

Verify Memory Information

You can view the memory information using the show watchdog memory-state command.

show watchdog memory-state location all

Displays memory snapshot in brief.

Example:

```
RP/0/RP0/CPU0:ios#show watchdog memory-state location all
Thu Jun 16 08:36:44.436 UTC
---- node0_RP0_CPU0 ----
Memory information:
  Physical Memory      : 31935.167 MB
  Free Memory          : 29236.0 MB
  Memory State         : Normal
```



CHAPTER 5

Upgrade Software and FPD

This chapter describes the procedures to upgrade software and FPDs.



Note The output of the examples in the procedures is not from the latest software release. The output will change for any explicit references to the current release.

- [Upgrade Software, on page 51](#)
- [Software Upgrade and Downgrade Matrix, on page 53](#)
- [Install Packages and RPMs, on page 53](#)
- [NCS 1010 FPD, on page 57](#)

Upgrade Software

Upgrading the software is the process of installing a new version of the Cisco IOS XR operating system on NCS 1010. NCS 1010 is preinstalled with the Cisco IOS XR image. However, you can install a new version to keep features up to date. You can perform the software upgrade operation using an ISO image from the XR mode.

Before you begin

- [Configure Management Interface](#)
- Copy the ISO image to be installed either on the NCS 1010 hard disk or on a network server to which NCS 1010 has access.

Step 1 Execute one of these commands:

- **install replace /harddisk:/iso-image-name**
- **install package replace** *<ftp or http or https protocol>/package_path/ filename1 filename2 ...*

Note The **install package replace** command upgrades the ISO image but doesn't reload the RP automatically. But the **install replace** command upgrades the ISO image and reloads the RP.

Example:

```
RP/0/RP0/CPU0:ios#install replace /harddisk:/ncs1010-x64.iso
Mon Jul 4 10:15:07.697 UTC
Once the packaging dependencies have been determined, the install operation may have to reload the
system.
If you want to control the timing of system reload, you must not continue, but use the 'install
package replace' command instead, followed by 'install apply'.
Continue? [yes/no]:[yes] yes
Install replace operation 1.1 has started
Install operation will continue in the background
.....
.....
ios con0/RP0/CPU0 is now available
```

Installs the new ISO image from the harddisk or from the network server. The install operation takes between 20–40 minutes to complete.

Note Boot time FPD upgrade happens before XR boot. All the FPDs belonging to the RP location are upgraded during the boot time FPD upgrade.

Note Automatic FPD upgrade is enabled by default.. When the automatic FPD upgrade is enabled, the install operation also upgrades the FPDs (except the Golden FPDs) that need to be upgraded.

Step 2 show install request

Example:

```
RP/0/RP0/CPU0:ios#show install request
Mon May 9 15:16:27.486 UTC
User request: install replace /harddisk:/ncs1010-x64.iso
Operation ID: 1.1
State:          In progress since 2022-05-09 15:13:08 UTC
Current activity: Package add or other package operation
Next activity:   Apply
Time started:    2022-05-09 15:14:34 UTC
Timeout in:     38m 6s
Locations responded: 0/1
Location          Packaging operation stage Notification Phase Clients responded
-----
0/RP0/CPU0        Package operations          None in progress          N/A
```

Displays the current status of the install operation.

When the install operation completes successfully, the device automatically reloads.

Note In case of the **install package replace** command, you'll be prompted to enter the next command (**install apply reload** command).

Step 3 install commit

Example:

```
RP/0/RP0/CPU0:ios#install commit
Mon May 9 15:24:28.581 UTC
Install commit operation 1 has started
Install operation will continue in the background
```

Commits the new ISO image.

Step 4 show install committed

Example:

```
RP/0/RP0/CPU0:ios#show install committed
Mon May 9 15:24:55.672 UTC
```

```

Software Hash: 9dfe3b29058bd85eccc3910fb6ea66bf7bf9ccaa9e7ef38c8e3499ab1d0e91f8
Package          Version
-----
xr-aaa           7.7.1
xr-acl           7.7.1
xr-apphosting   7.7.1
xr-appmgr       7.7.1
xr-bcdl         7.7.1
xr-bfd          7.7.1

```

Displays the list of committed packages.

Software Upgrade and Downgrade Matrix

The following table lists the upgrade and downgrade paths supported for Cisco NCS 1010.

Upgrade Path			Downgrade Path		
Source Release	Destination Release	Bridge SMU	Source Release	Destination Release	Bridge SMU
R7.10.1, R7.11.1, R7.11.2	R24.2.1	No	R24.2.1	R7.11.2, R7.11.1, R7.10.1	No

Install Packages and RPMs

Complete this task to install additional packages or rpm files. The rpm files that need to be installed must be placed in a folder.



Note This task can be used to install SMUs as well.

Before you begin

- Configure and connect to the management interface. You can access the installable file through the management interface. For details about configuring the management interface, see [Configure Management Interface, on page 28](#).
- Copy the package or rpm to be installed either on the NCS 1010 hard disk or on a network server to which NCS 1010 has access.

Step 1 `install package add source /harddisk:/ iso-image-name or rpm-folder-name`

Example:

```

RP/0/RP0/CPU0:ios#install package add source /harddisk:/rpm/
Mon Jul  4 11:37:31.526 UTC

```

```
Install add operation 2.1.1 has started
Install operation will continue in the background
```

Ensure to add the respective packages or rpm files as appropriate. This operation may take time depending on the size of the files that are added. The operation takes place in an asynchronous mode. The **install package add source** command runs in the background, and the EXEC prompt is returned.

Step 2 show install request

Example:

```
RP/0/RP0/CPU0:ios#show install request

Mon Jul  4 11:44:48.411 UTC

User request: install package add source file:///harddisk:/rpm/
Operation ID: 2.1.1
State:          Success since 2022-07-04 11:38:57 UTC

Current activity:  Await user input
Time started:     2022-07-04 11:38:57 UTC

The following actions are available:
  install package add
  install package remove
  install package upgrade
  install package downgrade
  install package abort latest
  install package abort all-since-apply
  install apply restart
  install apply reload
```

Least impactful apply method: install apply restart

Displays the current status of the install operation.

Step 3 install apply reload

Example:

```
RP/0/RP0/CPU0:ios#install apply reload

Mon Jul  4 11:45:18.434 UTC
Install apply operation 2.1 has started
Install operation will continue in the background
```

Enables NCS 1010 to reload.

Step 4 show install request

Example:

```
RP/0/RP0/CPU0:ios#show install request

Mon Jul  4 11:47:32.221 UTC

User request: install apply reload
Operation ID: 2.1
State:          Success since 2022-07-04 11:46:03 UTC

Current activity:  Await user input
Time started:     2022-07-04 11:46:03 UTC

The following actions are available:
  install package add
```

```

install package remove
install package upgrade
install package downgrade
install package replace
install package rollback
install replace
install rollback
install source
install commit

```

Displays the current status of the install operation.

Step 5 **install commit**

Example:

```

RP/0/RP0/CPU0:ios#install commit
Mon Jul  4 11:48:47.745 UTC
Install commit operation 2 has started
Install operation will continue in the background

```

Commits the package or rpm files.

Step 6 **show install request**

Example:

```

RP/0/RP0/CPU0:ios#show install request

User request: install commit
Operation ID: 2
State:        In progress since 2022-07-04 11:48:48 UTC

Current activity:  Commit transaction
Next activity:    Transaction complete
Time started:     2022-07-04 11:48:48 UTC

```

No per-location information.

Displays the current status of the install operation. The above output indicates that the install operation is in progress.

Step 7 **show install request**

Example:

```

RP/0/RP0/CPU0:ios#show install request

User request: install commit
Operation ID: 2
State:        Success since 2022-07-04 11:50:32 UTC

Current activity:  No install operation in progress

```

The following actions are available:

```

install package add
install package remove
install package upgrade
install package downgrade
install package replace
install package rollback
install replace
install rollback
install source

```

Displays the current status of the install operation. The above output indicates that the install operation is complete.

Step 8 show install active summary**Example:**

```
RP/0/RP0/CPU0:ios#show install active summary
```

```
Mon Jul 4 11:52:24.823 UTC
Active Packages: XR: 145 All: 1265
Label: 7.7.1
Software Hash: 3ce63ce432d50358d7a0d654ec61e4377abccf265013132e310b4d34a7259b90
```

Optional Packages	Version
-----	-----
xr-bgp	7.7.1
xr-ipsla	7.7.1
xr-is-is	7.7.1
xr-lldp	7.7.1
xr-mpls-oam	7.7.1
xr-netsim	7.7.1
xr-olc	7.7.1
xr-ospf	7.7.1
xr-perfmgmt	7.7.1
xr-telnet	7.7.1
xr-track	7.7.1

Displays the list of active packages and rpm files.

Step 9 show install committed summary**Example:**

```
RP/0/RP0/CPU0:ios#show install committed summary
```

```
Mon Jul 4 11:54:04.178 UTC
Committed Packages: XR: 145 All: 1265
Label: 7.7.1
Software Hash: 3ce63ce432d50358d7a0d654ec61e4377abccf265013132e310b4d34a7259b90
```

Optional Packages	Version
-----	-----
xr-bgp	7.7.1
xr-ipsla	7.7.1
xr-is-is	7.7.1
xr-lldp	7.7.1
xr-mpls-oam	7.7.1
xr-netsim	7.7.1
xr-olc	7.7.1
xr-ospf	7.7.1
xr-perfmgmt	7.7.1
xr-telnet	7.7.1
xr-track	7.7.1

Displays the list of committed packages and rpm files.

Related Commands

The following commands can be used to track the status of the install operation.

Related Commands	Purpose
show install active	Displays the list of active packages.

Related Commands	Purpose
<code>show install committed</code>	Displays the list of committed packages.
<code>show install log</code>	Displays the log information for the install operation. This information is used for troubleshooting in case of installation failure.
<code>show install package</code>	Displays the details of the packages that are added to the repository. Use this command to identify individual components of a package.
<code>show install request</code>	Displays the current status of the install operation.
<code>show install which</code>	Displays the package information on an installed file.

NCS 1010 FPD

A Field Programmable Device (FPD) refers to any programmable hardware device on a chassis, which includes a Field Programmable Gate Array (FPGA). NCS 1010 uses several FPDs that are necessary for chassis, route processor, line cards, and power modules to function properly.



Note During the software upgrade, when the SSD is upgraded, the FPD goes into the RELOAD_REQ state, as displayed by the `show hw-module fpd` command. This behavior is expected because the updated SSD firmware can only be activated after reloading the specific SSD location mentioned in the `show hw-module fpd` output.



Note If the FPD in a given SSD is not supported by the current IOS XR software release, the status is displayed as *NOT READY*. The status will change once FPD support for these SSDs is enabled in future releases.

The following table lists the NCS 1010 FPDs that are distributed across route processor (RP), power modules (PM), line cards (LC), and Rack.

Table 2: NCS 1010 FPDs

Location	FPDs
RP	<ul style="list-style-type: none"> • ADMConfig • CpuFpga • CpuFpgaGolden • BIOS • BIOS-Golden • SsdIntelS4510 • SsdMicron5300 • SsdSmartModular • TamFw • TamFwGolden
PM0 and PM1	<ul style="list-style-type: none"> • AP-PrimMCU • AP-SecMCU
LC	<ul style="list-style-type: none"> • ILA • OLT • Raman-1 • Raman-2
Rack	<ul style="list-style-type: none"> • IoFpga • IoFpgaGolden • EITU-ADMConfig • SsdIntelS4510 • SsdMicron5300 • SsdSmartModular

Golden FPDs serve as backup FPDs for the primary FPDs. For example, **BIOS-Golden** is the backup Golden FPD for the **BIOS** primary FPD. If a primary FPD is corrupted, NCS 1010 boots with the corresponding Golden FPD. The Golden FPDs cannot be upgraded.

Retrieve FPD Information

There are multiple types of FPDs for each type of module. The **show hw-module fpd** command provides information about each FPD.

```
RP/0/RP0/CPU0:ios#show hw-module fpd
```

REQ

Wed Jun 29 08:50:21.057 UTC

Auto-upgrade:Disabled

Location Reload Loc	Card type	HWver	FPD device	ATR Status	FPD Versions	
					Running	Programd
0/RP0/CPU0 NOT REQ	NCS1010-CNTRLR-K9	1.0	ADMConfig	CURRENT	3.40	3.40
0/RP0/CPU0 0/RP0	NCS1010-CNTRLR-K9	1.0	BIOS	S CURRENT	4.10	4.10
0/RP0/CPU0 0/RP0	NCS1010-CNTRLR-K9	1.0	BIOS-Golden	BS CURRENT		4.10
0/RP0/CPU0 0/RP0	NCS1010-CNTRLR-K9	1.0	CpuFpga	S CURRENT	1.02	1.02
0/RP0/CPU0 0/RP0	NCS1010-CNTRLR-K9	1.0	CpuFpgaGolden	BS CURRENT		1.01
0/RP0/CPU0 0/RP0	NCS1010-CNTRLR-K9	1.0	SsdIntelS4510	S CURRENT	11.32	11.32
0/RP0/CPU0 0/RP0	NCS1010-CNTRLR-K9	1.0	TamFw	S CURRENT	6.13	6.13
0/RP0/CPU0 0/RP0	NCS1010-CNTRLR-K9	1.0	TamFwGolden	BS CURRENT		6.11
0/PM0 NOT REQ	NCS1010-AC-PSU	0.0	AP-PrimMCU	CURRENT	1.03	1.03
0/PM0 NOT REQ	NCS1010-AC-PSU	0.0	AP-SecMCU	CURRENT	2.01	2.01
0/PM1 NOT REQ	NCS1010-AC-PSU	0.0	AP-PrimMCU	CURRENT	1.03	1.03
0/PM1 NOT REQ	NCS1010-AC-PSU	0.0	AP-SecMCU	CURRENT	2.01	2.01
0/0/NXR0 NOT REQ	NCS1K-ILA-C	1.0	ILA	S CURRENT	1.00	1.00
0/Rack NOT REQ	NCS1010-SA	1.0	EITU-ADMConfig	CURRENT	2.10	2.10
0/Rack NOT REQ	NCS1010-SA	1.0	IoFpga	S CURRENT	1.04	1.04
0/Rack NOT REQ	NCS1010-SA	1.0	IoFpgaGolden	BS CURRENT		1.01
0/Rack 0/Rack	NCS1010-SA	1.0	SsdIntelS4510	S CURRENT	11.32	11.32

The following table describes the significant fields in the output of the **show hw-module fpd** command.

Table 3: Description of Fields in show hw-module fpd Command

Field	Description
Location	Location of the FPD.
Card type	PID of the modules such as chassis, card, CPU, and PSU.
HWver	Hardware version where the FPD resides.
FPD device	Name of the FPD.

Field	Description
ATR	Attribute codes. The possible values are: <ul style="list-style-type: none"> • B - Golden Image • S - Secure Image • P - Protect Image <p>The attribute code of the primary FPDs is S and the Golden FPDs is BS.</p>
Status	Status of the FPD. See Table 4: Description of FPD Status Values in show hw-module fpd Command , on page 60.
Running	FPD image version that has been activated and currently running in the FPD device.
Programd	FPD image version that has been programmed into the FPD device, but might not be activated.
Reload Loc	Indicates whether reload of the location is required or not.

The following table describes the possible values of the Status field in the output of the **show hw-module fpd** command.

Table 4: Description of FPD Status Values in show hw-module fpd Command

FPD Status	Description
NOT READY	The driver that owns the FPD device has not initialized the FPD client to handle this device.
CURRENT	FPD version is up to date and upgrade is not required.
NEED UPGD	Upgrade is required for this FPD. Check the output of the show fpd package command to determine the recommended FPD version.
UPGD PREP	FPD is preparing for upgrade.
IN QUEUE	Upgrade of this FPD is in queue.
UPGD SKIP	FPD upgrade is not required. For example, <ul style="list-style-type: none"> • FPD version is up to date and compatible. • FPD image is protected.
UPGRADING	FPD upgrade started and the driver did not report the upgrade progress information yet.
%UPGD	Percentage of FPD upgrade completion.

FPD Status	Description
RLOAD REQ	FPD upgrade is successfully completed and the FPD must be reloaded for the new version to take effect.
UPGD FAIL	FPD upgrade has failed. Check the syslog for failure reason. It could be a timeout or a failure that is reported by the driver.
UPGD DONE	FPD upgrade is successfully completed.

Verify if an FPD Upgrade is Required

Step 1 Use the **show hw-module fpd** command to check whether all the FPDs are in the Current state.

If the status of any FPD is **NEED UPGD**, then the upgrade is required for that FPD.

Step 2 Use the **show fpd package** command to determine the FPDs that are supported with the current software release and the minimum hardware requirements for each FPD.

```
RP/0/RP0/CPU0:ios#show fpd package
Wed Jun 29 08:50:21.057 UTC
```

```
=====
                                Field Programmable Device Package
                                =====
Card Type           FPD Description           Req   SW   Min Req   Min Req
=====           =====           Reload Ver   SW Ver   Board Ver
=====           =====           =====
NCS1010-AC-PSU     AP-PrimMCU                NO    1.03   1.03     0.0
                   AP-SecMCU                 NO    2.01   2.01     0.0
-----
NCS1010-CNTRLR-K9 ADMConfig                 NO    2.30   2.30     0.0
                   ADMConfig                 NO    2.30   2.30     0.0
                   ADMConfig                 NO    3.40   3.30     1.0
                   BIOS                     YES    4.10   4.10     0.0
                   BIOS                     YES    4.10   4.10     0.0
                   BIOS-Golden              YES    4.10   4.10     0.0
                   BIOS-Golden              YES    4.10   4.10     0.0
                   CpuFpga                  YES    1.02   1.02     0.0
                   CpuFpga                  YES    1.02   1.02     0.0
                   CpuFpgaGolden           YES    1.01   1.01     0.0
                   CpuFpgaGolden           YES    1.01   1.01     0.0
                   SsdIntelS4510           YES   11.32  11.32     0.0
                   SsdIntelS4510           YES   11.32  11.32     0.0
                   SsdMicron5300           YES    0.01   0.01     0.0
                   SsdMicron5300           YES    0.01   0.01     0.0
                   SsdSmartModular        YES   13.06  13.06     0.0
                   SsdSmartModular        YES   13.06  13.06     0.0
                   TamFw                   YES    6.13   6.13     0.0
                   TamFw                   YES    6.13   6.13     0.0
                   TamFwGolden            YES    6.11   6.11     0.0
                   TamFwGolden            YES    6.11   6.11     0.0
-----
NCS1010-SA         EITU-ADMConfig           NO    1.04   1.04     0.0
                   EITU-ADMConfig           NO    2.10   2.10     1.0
                   EITU-ADMConfig           NO    1.04   1.04     0.0
                   EITU-ADMConfig           NO    2.10   2.10     1.0
```

	IoFpga	NO	1.04	1.04	0.0
	IoFpga	NO	1.04	1.04	0.0
	IoFpgaGolden	NO	1.01	1.01	0.0
	IoFpgaGolden	NO	1.01	1.01	0.0
	SsdIntelS4510	YES	11.32	11.32	0.0
	SsdIntelS4510	YES	11.32	11.32	0.0
	SsdMicron5300	YES	0.01	0.01	0.0
	SsdMicron5300	YES	0.01	0.01	0.0
	SsdSmartModular	YES	13.06	13.06	0.0
	SsdSmartModular	YES	13.06	13.06	0.0

NCS1K-ILA-2R-C	ILA	NO	1.00	1.00	0.1
	ILA	NO	0.23	0.23	99.1
	Raman-1	NO	1.00	1.00	0.1
	Raman-1	NO	0.23	0.23	99.1
	Raman-2	NO	1.00	1.00	0.1
	Raman-2	NO	0.23	0.23	99.1

NCS1K-ILA-C	ILA	NO	1.00	1.00	0.1
	ILA	NO	0.23	0.23	99.1

NCS1K-ILA-R-C	ILA	NO	1.00	1.00	0.1
	ILA	NO	0.23	0.23	99.1
	Raman-1	NO	1.00	1.00	0.1
	Raman-1	NO	0.23	0.23	99.1

NCS1K-OLT-C	OLT	NO	1.00	1.00	0.1
	OLT	NO	0.23	0.23	99.1

NCS1K-OLT-R-C	OLT	NO	1.00	1.00	0.1
	OLT	NO	0.23	0.23	99.1
	Raman-1	NO	1.00	1.00	0.1
	Raman-1	NO	0.23	0.23	99.1

The following table describes the fields in the output of the **show fpd package** command.

Table 5: Description of Fields in show fpd package Command

Field	Description
Card Type	PID of the modules such as chassis, card, CPU, and PSU.
FPD Description	Description of the FPD.
Req Reload	Determines whether reload is required to activate the FPD image.
SW Ver	Recommended FPD software version for the associated module running the current Cisco IOS XR Software.
Min Req SW Ver	Minimum required FPD software version to operate the module.
Min Req Board Ver	Minimum required hardware version for the associated FPD. A minimum hardware requirement of version 0.0 indicates that all the hardware can support this FPD version.

FPD can be upgraded using two methods:

- [Upgrade FPDs Manually](#)

- [Upgrade FPDs Automatically](#)

Upgrade FPDs Manually

Use the following procedure to upgrade the FPDs manually.



Note The Golden FPDs cannot be upgraded using the CLI.

-
- Step 1** Use the **show hw-module fpd** command to display information about the current FPD version.
You can use this command to determine if you must upgrade the FPD.
- Step 2** Use the **show alarms brief system active** command to display the active alarms.
You must upgrade the FPD when the **One Or More FPDs Need Upgrade Or Not In Current State** alarm is present.
- Step 3** Use the **upgrade hw-module location [location-id] fpd [fpd name]** command to upgrade a specific FPD.
After upgrading the FPD, the user must wait for upgrade completion. The progress of the FPD upgrade can be monitored using the **show hw-module fpd** command.
- Example:**
- ```
RP/0/RP0/CPU0:ios#upgrade hw-module location 0/Rack fpd IoFpga
```
- Note** The FPDs of power modules belong to 0/PM0 and 0/PM1 locations. The FPDs belonging to both the PM locations cannot be simultaneously upgraded.
- Step 4** Use the **reload location location-id** to reload the FPDs belonging to a specific location with the new version.  
The **Reload Loc** field in the output of **show hw-module fpd** command indicates whether the reload is required or not.
- Example:**
- ```
RP/0/RP0/CPU0:ios#reload location 0/RP0/CPU0
```
- Step 5** (Optional) Use the **upgrade hw-module location all fpd all** command to upgrade all the FPDs at once.
- Step 6** (Optional) Use the **upgrade hw-module [location [location-id | all]] fpd [fpd name] | all** command to upgrade a specific FPD, all the FPDs, or the FPDs belonging to a specific location.
- Example:**
- ```
RP/0/RP0/CPU0:ios#upgrade hw-module location all fpd all
```
- Note** The FPDs of power modules and SSDs cannot be forcefully upgraded.
-

## Upgrade FPDs Automatically

The automatic FPD upgrade upgrades the FPD version of all the modules to the latest version. When automatic FPD upgrade is enabled, all the FPDs (except the Golden FPDs) that are in NEED UPGD status are upgraded to CURRENT status during the software upgrade.

In NCS 1010, automatic FPD upgrade is enabled by default.

---

Use the following commands to disable automatic FPD upgrade.

**Example:**

```
RP/0/RP0/CPU0:ios#configure
RP/0/RP0/CPU0:ios(config)#fpd auto-upgrade disable
RP/0/RP0/CPU0:ios(config)#commit
RP/0/RP0/CPU0:ios(config)#end
```

---



## CHAPTER 6

# Remote Node Management in NCS 1010

This chapter describes how to manage an ILA node remotely in NCS 1010 by the remote node management feature.

- [Understanding Remote Node Management Using OSC, on page 65](#)
- [Prerequisites, on page 65](#)
- [DHCP Relay Configuration for OLT Node, on page 66](#)
- [Loopback IP address for OSC Interface, on page 67](#)
- [OSPF Neighbor Discovery, on page 67](#)
- [Configure ILA Node, on page 68](#)
- [Configure OLT Node, on page 68](#)

## Understanding Remote Node Management Using OSC

The remote node management feature in NCS 1010 allows you to remotely manage an ILA node that is not connected to a management network through an OLT gateway node over Optical Supervisory Channel (OSC) interface. The OLT node is connected to a management network and manages ILA node remotely. If the OLT node link is down, the ILA node cannot be accessible.

## Prerequisites

The remote node management for ILA node works only if the following conditions are met:

- The DSCP relay configuration for OLT node must be present. See [DHCP Relay Configuration for OLT Node, on page 66](#)
- The loopback address and IP address must be present for OSC interface. See [Loopback IP address for OSC Interface, on page 67](#)
- The OSPF neighbor discovery must be successful between OLT and ILA nodes. See [OSPF Neighbor Discovery, on page 67](#)

# DHCP Relay Configuration for OLT Node

The OLT node must be configured with the DHCP management connection to manage the ILA node remotely over OSC interface.

Figure 6: DHCP Relay Configuration for OLT Node

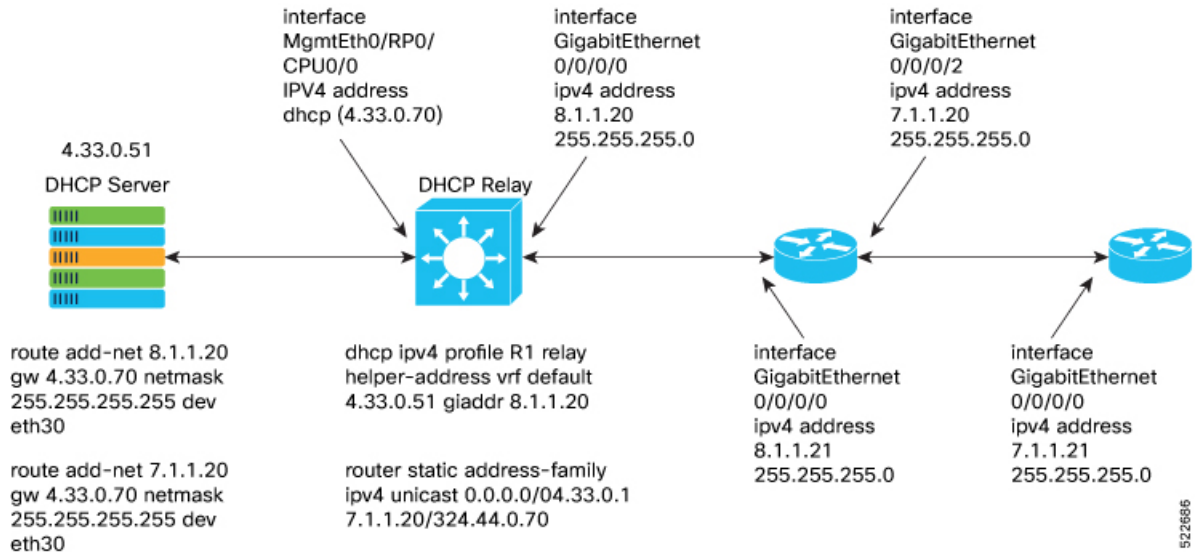

Following is the sample DHCP relay configuration for the OLT gateway node:

```

RP/0/RP0/CPU0:P2B_DT_02#sh running-config int mgmtEth 0/RP0/CPU0/2
Thu Jun 9 06:37:59.071 UTC
interface MgmtEth0/RP0/CPU0/2
 ipv4 address 192.168.1.1 255.255.255.252
!

RP/0/RP0/CPU0:P2B_DT_02#

RP/0/RP0/CPU0:P2C_DT_02#

RP/0/RP0/CPU0:P2B_DT_02#sh running-config dhcp ipv4
Thu Jun 9 06:28:51.879 UTC
dhcp ipv4
 profile R1 relay
 helper-address vrf default 10.4.33.51 giaddr 10.8.1.20
 !
 interface GigabitEthernet0/0/0/0 relay profile R1
 !

```

In the above sample CLI,

- **10.4.33.51** is the DHCP server IP address
- **10.8.1.20** is the OSC interface IP address that going to ILA node from OLT node
- **0/0/0/0** is the interface number
- **R1** is the profile



Sample command for DHCP server:

```
3) Config on dhcp server:
route add -net <OLT-OSCIp> gw <OLT-MGMTip> netmask 255.255.255.255 dev eth3

route add -net 10.8.1.20 gw 10.4.33.70 netmask 255.255.255.255 dev eth3
route add -net 10.7.1.20 gw 10.4.33.70 netmask 255.255.255.255 dev eth3
Config on OLT:
dhcp ipv4 profile R1 relay helper-address vrf default 10.4.33.51 giaddr 10.8.1.20
router static
address-family ipv4 unicast
 0.0.0.0/0 10.4.33.1
 10.7.1.20/32 10.4.44.70
interface MgmtEth0/RP0/CPU0/0
ipv4 address dhcp
interface GigabitEthernet0/0/0/0
ipv4 address 10.8.1.20 255.255.255.0
```

## Loopback IP address for OSC Interface

The loopback IP address must be mapped for the OSC interface.



**Note** The loopback IP address is essential as it acts as a router ID for the OSPF configuration. Many communication protocols such as: SSH, GRPC and optical applications, and remote login need the router ID for OSPF configuration. .

Following is the sample of loopback and IP address for OSC interface:

```
RP/0/RP0/CPU0:P2B_DT_02#sh running-config interface loopback 0
Thu Jun 9 06:29:00.447 UTC
interface Loopback0
 ipv4 address 10.3.3.20 255.255.255.255
!
```

## OSPF Neighbor Discovery

The OSPF neighbor discovery indicates the successful connection between OLT and ILA node.

Following is the sample CLI:

```
RP/0/RP0/CPU0:IOS#show ospf neighbor
Tue Jul 26 07:31:29.532 UTC
* Indicates MADJ interface
Indicates Neighbor awaiting BFD session up
Neighbors for OSPF 1
Neighbor ID Pri State Dead Time Address Interface
198.51.100.1 1 FULL/ - 00:00:35 10.8.1.21 GigabitEthernet0/0/0/0
Neighbor is up for 00:00:42

Total neighbor count: 1
RP/0/RP0/CPU0:IOS#
```

In the above CLI,

- **198.51.100.1** is the neighbor IP address

- 10.8.1.21 is the OSC interface IP address

## Configure ILA Node

The following is a sample command for ILA node configuration:

```
interface GigabitEthernet0/0/0/0
ipv4 address 10.8.1.21 255.255.255.0
!
interface GigabitEthernet0/0/0/2
ipv4 address 10.7.1.21 255.255.255.0

router ospf 1
distribute link-state
network point-to-point
redistribute connected
area 0
 interface Loopback0
 !
 interface GigabitEthernet0/0/0/0
 !
 interface GigabitEthernet0/0/0/2
```

## Configure OLT Node

The following is a sample command to configure the OLT node with loopback ip:

Configure

```
interface Loopback0
ipv4 address 10.3.3.21 255.255.255.255
!
interface GigabitEthernet0/0/0/0
ipv4 address 10.7.1.20 255.255.255.0
router ospf 1
distribute link-state
network point-to-point
area 0
 interface Loopback0
 !
 interface GigabitEthernet0/0/0/0
```

-