



## **Cisco 815 Integrated Services Router Hardware Installation Guide**

### **Corporate Headquarters**

Cisco Systems, Inc.  
170 West Tasman Drive  
San Jose, CA 95134-1706  
USA  
<http://www.cisco.com>  
Tel: 408 526-4000  
800 553-NETS (6387)  
Fax: 408 526-4100

Text Part Number: OL-9558-01



THE SPECIFICATIONS AND INFORMATION REGARDING THE PRODUCTS IN THIS MANUAL ARE SUBJECT TO CHANGE WITHOUT NOTICE. ALL STATEMENTS, INFORMATION, AND RECOMMENDATIONS IN THIS MANUAL ARE BELIEVED TO BE ACCURATE BUT ARE PRESENTED WITHOUT WARRANTY OF ANY KIND, EXPRESS OR IMPLIED. USERS MUST TAKE FULL RESPONSIBILITY FOR THEIR APPLICATION OF ANY PRODUCTS.

THE SOFTWARE LICENSE AND LIMITED WARRANTY FOR THE ACCOMPANYING PRODUCT ARE SET FORTH IN THE INFORMATION PACKET THAT SHIPPED WITH THE PRODUCT AND ARE INCORPORATED HEREIN BY THIS REFERENCE. IF YOU ARE UNABLE TO LOCATE THE SOFTWARE LICENSE OR LIMITED WARRANTY, CONTACT YOUR CISCO REPRESENTATIVE FOR A COPY.

The following information is for FCC compliance of Class A devices: This equipment has been tested and found to comply with the limits for a Class A digital device, pursuant to part 15 of the FCC rules. These limits are designed to provide reasonable protection against harmful interference when the equipment is operated in a commercial environment. This equipment generates, uses, and can radiate radio-frequency energy and, if not installed and used in accordance with the instruction manual, may cause harmful interference to radio communications. Operation of this equipment in a residential area is likely to cause harmful interference, in which case users will be required to correct the interference at their own expense.

The following information is for FCC compliance of Class B devices: The equipment described in this manual generates and may radiate radio-frequency energy. If it is not installed in accordance with Cisco's installation instructions, it may cause interference with radio and television reception. This equipment has been tested and found to comply with the limits for a Class B digital device in accordance with the specifications in part 15 of the FCC rules. These specifications are designed to provide reasonable protection against such interference in a residential installation. However, there is no guarantee that interference will not occur in a particular installation.

Modifying the equipment without Cisco's written authorization may result in the equipment no longer complying with FCC requirements for Class A or Class B digital devices. In that event, your right to use the equipment may be limited by FCC regulations, and you may be required to correct any interference to radio or television communications at your own expense.

You can determine whether your equipment is causing interference by turning it off. If the interference stops, it was probably caused by the Cisco equipment or one of its peripheral devices. If the equipment causes interference to radio or television reception, try to correct the interference by using one or more of the following measures:

- Turn the television or radio antenna until the interference stops.
- Move the equipment to one side or the other of the television or radio.
- Move the equipment farther away from the television or radio.
- Plug the equipment into an outlet that is on a different circuit from the television or radio. (That is, make certain the equipment and the television or radio are on circuits controlled by different circuit breakers or fuses.)

Modifications to this product not authorized by Cisco Systems, Inc. could void the FCC approval and negate your authority to operate the product.

The Cisco implementation of TCP header compression is an adaptation of a program developed by the University of California, Berkeley (UCB) as part of UCB's public domain version of the UNIX operating system. All rights reserved. Copyright © 1981, Regents of the University of California.

NOTWITHSTANDING ANY OTHER WARRANTY HEREIN, ALL DOCUMENT FILES AND SOFTWARE OF THESE SUPPLIERS ARE PROVIDED "AS IS" WITH ALL FAULTS. CISCO AND THE ABOVE-NAMED SUPPLIERS DISCLAIM ALL WARRANTIES, EXPRESSED OR IMPLIED, INCLUDING, WITHOUT LIMITATION, THOSE OF MERCHANTABILITY, FITNESS FOR A PARTICULAR PURPOSE AND NONINFRINGEMENT OR ARISING FROM A COURSE OF DEALING, USAGE, OR TRADE PRACTICE.

IN NO EVENT SHALL CISCO OR ITS SUPPLIERS BE LIABLE FOR ANY INDIRECT, SPECIAL, CONSEQUENTIAL, OR INCIDENTAL DAMAGES, INCLUDING, WITHOUT LIMITATION, LOST PROFITS OR LOSS OR DAMAGE TO DATA ARISING OUT OF THE USE OR INABILITY TO USE THIS MANUAL, EVEN IF CISCO OR ITS SUPPLIERS HAVE BEEN ADVISED OF THE POSSIBILITY OF SUCH DAMAGES.

CCSP, CCVP, the Cisco Square Bridge logo, Follow Me Browsing, and StackWise are trademarks of Cisco Systems, Inc.; Changing the Way We Work, Live, Play, and Learn, and iQuick Study are service marks of Cisco Systems, Inc.; and Access Registrar, Aironet, BPX, Catalyst, CCDA, CCDP, CCIE, CCIP, CCNA, CCNP, Cisco, the Cisco Certified Internetwork Expert logo, Cisco IOS, Cisco Press, Cisco Systems, Cisco Systems Capital, the Cisco Systems logo, Cisco Unity, Enterprise/Solver, EtherChannel, EtherFast, EtherSwitch, Fast Step, FormShare, GigaDrive, GigaStack, HomeLink, Internet Quotient, IOS, IP/TV, iQ Expertise, the iQ logo, iQ Net Readiness Scorecard, LightStream, Linksys, MeetingPlace, MGX, the Networkers logo, Networking Academy, Network Registrar, *Packet*, PIX, Post-Routing, Pre-Routing, ProConnect, RateMUX, ScriptShare, SlideCast, SMARTnet, The Fastest Way to Increase Your Internet Quotient, and TransPath are registered trademarks of Cisco Systems, Inc. and/or its affiliates in the United States and certain other countries.

All other trademarks mentioned in this document or Website are the property of their respective owners. The use of the word partner does not imply a partnership relationship between Cisco and any other company. (0601R)

*Cisco 815 Integrated Services Router Hardware Installation Guide*

© 2006 Cisco Systems, Inc. All rights reserved.





## **Preface ix**

Audience and Scope **ix**

Organization **ix**

Related Documentation **x**

Conventions **xi**

Notes, Cautions, and Warnings **xi**

Commands **xviii**

Accessibility **xix**

Obtaining Documentation **xix**

Cisco.com **xix**

Product Documentation DVD **xx**

Ordering Documentation **xx**

Documentation Feedback **xxi**

Cisco Product Security Overview **xxi**

Reporting Security Problems in Cisco Products **xxii**

Obtaining Technical Assistance **xxiii**

Cisco Technical Support & Documentation Website **xxiii**

Cisco Product Identification Tool **xxiii**

Submitting a Service Request **xxiv**

Definitions of Service Request Severity **xxiv**

Obtaining Additional Publications and Information **xxv**

---

## **CHAPTER 1**

### **Overview 1-1**

Key Features **1-1**

- Product Serial Number Location 1-3
- Back Panel Ports and LEDs 1-4
- Front Panel LEDs 1-6
- Router Memory 1-8
  - Types of Memory 1-8
  - Amounts of Memory 1-9
- Unpacking the Router 1-10

---

**CHAPTER 2**

**Installation 2-1**

- Before Installing the Router 2-1
- Connecting the Router to Your Local Network 2-2
- Connecting Power to the Router 2-5
- Verifying Your Installation 2-6
- Optional Installation Procedures 2-7
  - Connecting a PC 2-7
  - Connecting a Modem 2-9
  - Stacking the Router 2-10
  - Unstacking the Router 2-13

---

**CHAPTER 3**

**Troubleshooting 3-1**

- Contacting Your Cisco Reseller 3-1
- Recovering a Lost Password 3-2
  - Determining the Configuration Register Value 3-2
  - Resetting the Router 3-4
  - Resetting the Password 3-6
  - Resetting the Configuration Register Value 3-6
- Problem Solving 3-7
  - OK LED Diagnostics 3-7

Troubleshooting WICs and Cables	3-8
Example	3-9
Troubleshooting the Power System	3-11

---

**APPENDIX A****Technical Specifications** A-1

---

**APPENDIX B****Cabling Specifications** B-1

Ethernet Cables	B-1
Ethernet Network Cabling Guidelines	B-2
Console Cable and Adapter	B-3

---

**APPENDIX C****Installing and Upgrading Memory and Virtual Private Network Modules** C-1

Safety Warnings	C-1
Opening the Chassis	C-2
Locating Modules	C-4
Installing and Removing a DIMM	C-4
Removing a DIMM	C-5
Installing a DIMM	C-6
Installing a VPN Module	C-7
Closing the Chassis	C-13

---

**INDEX**







## Preface

---

This section describes the intended audience, scope, and organization of the *Cisco 815 Integrated Services Router Hardware Installation Guide* and defines the conventions used to convey instructions and information.

## Audience and Scope

This guide is for users who have some experience in installing and maintaining networking hardware. Cisco 815 integrated services router users should be familiar with the terminology and concepts of local Ethernet and wide-area networking.

This guide describes the functional and physical features of the Cisco 815 integrated services router and provides installation procedures, troubleshooting information, technical specifications, and cable and connector guidelines and specifications.

## Organization

This guide is organized as follows:

- [Chapter 1, “Overview,”](#) describes the router features, LEDs, and connectors.
- [Chapter 2, “Installation,”](#) describes how to install the router by connecting cables and power, and tells how to install WAN interface cards (WICs).

- [Chapter 3, “Troubleshooting,”](#) describes some problems that you might experience with the router and how to solve these problems.
- [Appendix A, “Technical Specifications,”](#) lists the physical characteristics, environmental requirements, and power specifications for the router.
- [Appendix B, “Cabling Specifications,”](#) provides the cables and cabling guidelines for the router.
- [Appendix C, “Installing and Upgrading Memory and Virtual Private Network Modules,”](#) describes how to install or upgrade memory modules in your router.

## Related Documentation

The following publications provide information related to this product:

- The *Cisco 815 Integrated Services Router Hardware Installation Guide*, has instructions for quickly cabling and powering up the router.
- *Cisco Cable Modem High-Speed WAN Interface Cards Feature Guide* describes some common network scenarios and how to use the Cisco IOS command-line interface (CLI) to configure the router in these scenarios.
- *Cisco WAN Interface Cards Hardware Installation Guide* describes how to install and configure the WAN interface cards (WICs) that are supported by the Cisco 815 router.
- Cisco IOS command reference and configuration guides provide complete information about all Cisco IOS CLI commands and how to use them, as well as information on designing and configuring LANs and WANs.

# Conventions

This guide uses the following conventions for information and instructions.

## Notes, Cautions, and Warnings

Notes, cautions, and warnings use the following conventions and symbols:

**Note**

---

Means *reader take note*. Notes contain helpful suggestions or references to materials not contained in this manual.

---

**Caution**

---

This caution symbol means *reader be careful*. In this situation, you might do something that could result in equipment damage or loss of data.

---

**Warning**

---

**This warning symbol means *danger*. You are in a situation that could cause bodily injury. Before you work on any equipment, be aware of the hazards involved with electrical circuitry and be familiar with standard practices for preventing accidents. To see translations of the warnings that appear in this publication, refer to the *Regulatory Compliance and Safety Information* document that accompanied this device.**

---

**Waarschuwing**

**Dit waarschuwingssymbool betekent gevaar. U verkeert in een situatie die lichamelijk letsel kan veroorzaken. Voordat u aan enige apparatuur gaat werken, dient u zich bewust te zijn van de bij elektrische schakelingen betrokken risico's en dient u op de hoogte te zijn van standaard maatregelen om ongelukken te voorkomen. Voor vertalingen van de waarschuwingen die in deze publicatie verschijnen, kunt u het document *Regulatory Compliance and Safety Information* (Informatie over naleving van veiligheids- en andere voorschriften) raadplegen dat bij dit toestel is ingesloten.**

<b>Varoitus</b>	<b>Tämä varoitusmerkki merkitsee vaaraa. Olet tilanteessa, joka voi johtaa ruumiinvammaan. Ennen kuin työskentelet minkään laitteiston parissa, ota selvää sähkökytkentöihin liittyvistä vaaroista ja tavanomaisista onnettomuuksien ehkäisykeinoista. Tässä julkaisussa esiintyvien varoitusten käännökset löydät laitteen mukana olevasta <i>Regulatory Compliance and Safety Information</i> -kirjasesta (määräysten noudattaminen ja tietoa turvallisuudesta).</b>
<b>Attention</b>	<b>Ce symbole d'avertissement indique un danger. Vous vous trouvez dans une situation pouvant causer des blessures ou des dommages corporels. Avant de travailler sur un équipement, soyez conscient des dangers posés par les circuits électriques et familiarisez-vous avec les procédures couramment utilisées pour éviter les accidents. Pour prendre connaissance des traductions d'avertissements figurant dans cette publication, consultez le document <i>Regulatory Compliance and Safety Information</i> (Conformité aux règlements et consignes de sécurité) qui accompagne cet appareil.</b>
<b>Warnung</b>	<b>Dieses Warnsymbol bedeutet Gefahr. Sie befinden sich in einer Situation, die zu einer Körperverletzung führen könnte. Bevor Sie mit der Arbeit an irgendeinem Gerät beginnen, seien Sie sich der mit elektrischen Stromkreisen verbundenen Gefahren und der Standardpraktiken zur Vermeidung von Unfällen bewußt. Übersetzungen der in dieser Veröffentlichung enthaltenen Warnhinweise finden Sie im Dokument <i>Regulatory Compliance and Safety Information</i> (Informationen zu behördlichen Vorschriften und Sicherheit), das zusammen mit diesem Gerät geliefert wurde.</b>
<b>Avvertenza</b>	<b>Questo simbolo di avvertenza indica un pericolo. La situazione potrebbe causare infortuni alle persone. Prima di lavorare su qualsiasi apparecchiatura, occorre conoscere i pericoli relativi ai circuiti elettrici ed essere al corrente delle pratiche standard per la prevenzione di incidenti. La traduzione delle avvertenze riportate in questa pubblicazione si trova nel documento <i>Regulatory Compliance and Safety Information</i> (Conformità alle norme e informazioni sulla sicurezza) che accompagna questo dispositivo.</b>

- Advarsel** Dette varselsymbolet betyr fare. Du befinner deg i en situasjon som kan føre til personskade. Før du utfører arbeid på utstyr, må du være oppmerksom på de faremomentene som elektriske kretser innebærer, samt gjøre deg kjent med vanlig praksis når det gjelder å unngå ulykker. Hvis du vil se oversettelser av de advarslene som finnes i denne publikasjonen, kan du se i dokumentet *Regulatory Compliance and Safety Information* (Overholdelse av forskrifter og sikkerhetsinformasjon) som ble levert med denne enheten.
- Aviso** Este símbolo de aviso indica perigo. Encontra-se numa situação que lhe poderá causar danos físicos. Antes de começar a trabalhar com qualquer equipamento, familiarize-se com os perigos relacionados com circuitos eléctricos, e com quaisquer práticas comuns que possam prevenir possíveis acidentes. Para ver as traduções dos avisos que constam desta publicação, consulte o documento *Regulatory Compliance and Safety Information* (Informação de Segurança e Disposições Reguladoras) que acompanha este dispositivo.
- ¡Advertencia!** Este símbolo de aviso significa peligro. Existe riesgo para su integridad física. Antes de manipular cualquier equipo, considerar los riesgos que entraña la corriente eléctrica y familiarizarse con los procedimientos estándar de prevención de accidentes. Para ver una traducción de las advertencias que aparecen en esta publicación, consultar el documento titulado *Regulatory Compliance and Safety Information* (Información sobre seguridad y conformidad con las disposiciones reglamentarias) que se acompaña con este dispositivo.
- Varning!** Denna varningssymbol signalerar fara. Du befinner dig i en situation som kan leda till personskada. Innan du utför arbete på någon utrustning måste du vara medveten om farorna med elkretsar och känna till vanligt förfarande för att förebygga skador. Se förklaringar av de varningar som förkommer i denna publikation i dokumentet *Regulatory Compliance and Safety Information* (Efterrättelse av föreskrifter och säkerhetsinformation), vilket medföljer denna anordning.

**Figyelem**      **FONTOS BIZTONSÁGI ELOÍRÁSOK**

**Ez a figyelmeztető jel veszélyre utal. Sérülésveszélyt rejtő helyzetben van. Mielőtt bármely berendezésen munkát végezte, legyen figyelemmel az elektromos áramkörök okozta kockázatokra, és ismerkedjen meg a szokásos balesetvédelmi eljárásokkal. A kiadványban szereplő figyelmeztetések fordítása a készülékhez mellékelt biztonsági figyelmeztetések között található; a fordítás az egyes figyelmeztetések végén látható szám alapján kereshető meg.**

**ORIZZE MEG EZEKET AZ UTASÍTÁSOKAT!****Предупреждение**      **ВАЖНЫЕ ИНСТРУКЦИИ ПО СОБЛЮДЕНИЮ ТЕХНИКИ БЕЗОПАСНОСТИ**

**Этот символ предупреждения обозначает опасность. То есть имеет место ситуация, в которой следует опасаться телесных повреждений. Перед эксплуатацией оборудования выясните, каким опасностям может подвергаться пользователь при использовании электрических цепей, и ознакомьтесь с правилами техники безопасности для предотвращения возможных несчастных случаев. Воспользуйтесь номером заявления, приведенным в конце каждого предупреждения, чтобы найти его переведенный вариант в переводе предупреждений по безопасности, прилагаемом к данному устройству.**

**СОХРАНИТЕ ЭТИ ИНСТРУКЦИИ****警告**      **重要的安全性说明**

**此警告符号代表危险。您正处于可能受到严重伤害的工作环境中。在您使用设备开始工作之前，必须充分意识到触电的危险，并熟练掌握防止事故发生的标准工作程序。请根据每项警告结尾提供的声明号码来找到此设备的安全性警告说明的翻译文本。**

**请保存这些安全性说明**

**警告** 安全上の重要な注意事項

「危険」の意味です。人身事故を予防するための注意事項が記述されています。装置の取り扱い作業を行うときは、電気回路の危険性に注意し、一般的な事故防止策に留意してください。警告の各国語版は、各注意事項の番号を基に、装置に付属の「Translated Safety Warnings」を参照してください。

これらの注意事項を保管しておいてください。

**주의** 중요 안전 지침

이 경고 기호는 위험을 나타냅니다. 작업자가 신체 부상을 일으킬 수 있는 위험한 환경에 있습니다. 장비에 작업을 수행하기 전에 전기 회로와 관련된 위험을 숙지하고 표준 작업 관례를 숙지하여 사고를 방지하십시오. 각 경고의 마지막 부분에 있는 경고문 번호를 참조하여 이 장치와 함께 제공되는 번역된 안전 경고문에서 해당 번역문을 찾으십시오.

이 지시 사항을 보관하십시오.

**تحذير****إرشادات الأمان الهامة**

يوضح رمز التحذير هذا وجود خطر. وهذا يعني أنك متواجد في مكان قد ينتج عنه التعرض لإصابات. قبل بدء العمل، احذر مخاطر التعرض للصدمات الكهربائية وكن على علم بالإجراءات القياسية للحيلولة دون وقوع أي حوادث. استخدم رقم البيان الموجود في آخر كل تحذير لتحديد مكان ترجمته داخل تحذيرات الأمان المترجمة التي تأتي مع الجهاز. قم بحفظ هذه الإرشادات

**Upozorenje** VAŽNE SIGURNOSNE NAPOMENE

Ovaj simbol upozorenja predstavlja opasnost. Nalazite se u situaciji koja može prouzročiti tjelesne ozljede. Prije rada s bilo kojim uređajem, morate razumjeti opasnosti vezane uz električne sklopove, te biti upoznati sa standardnim načinima izbjegavanja nesreća. U prevedenim sigurnosnim upozorenjima, priloženima uz uređaj, možete prema broju koji se nalazi uz pojedino upozorenje pronaći i njegov prijevod.

**SAČUVAJTE OVE UPUTE**

**Upozornění DŮLEŽITÉ BEZPEČNOSTNÍ POKYNY**

Tento upozorňující symbol označuje nebezpečí. Jste v situaci, která by mohla způsobit nebezpečí úrazu. Před prací na jakémkoliv vybavení si uvědomte nebezpečí související s elektrickými obvody a seznamte se se standardními opatřeními pro předcházení úrazům. Podle čísla na konci každého upozornění vyhledejte jeho překlad v přeložených bezpečnostních upozorněních, která jsou přiložena k zařízení.

**USCHOVEJTE TYTO POKYNY****Προειδοποίηση ΣΗΜΑΝΤΙΚΕΣ ΟΔΗΓΙΕΣ ΑΣΦΑΛΕΙΑΣ**

Αυτό το προειδοποιητικό σύμβολο σημαίνει κίνδυνο. Βρίσκεστε σε κατάσταση που μπορεί να προκαλέσει τραυματισμό. Πριν εργαστείτε σε οποιοδήποτε εξοπλισμό, να έχετε υπόψη σας τους κινδύνους που σχετίζονται με τα ηλεκτρικά κυκλώματα και να έχετε εξοικειωθεί με τις συνήθεις πρακτικές για την αποφυγή ατυχημάτων. Χρησιμοποιήστε τον αριθμό δήλωσης που παρέχεται στο τέλος κάθε προειδοποίησης, για να εντοπίσετε τη μετάφρασή της στις μεταφρασμένες προειδοποιήσεις ασφαλείας που συνοδεύουν τη συσκευή.

**ΦΥΛΑΞΤΕ ΑΥΤΕΣ ΤΙΣ ΟΔΗΓΙΕΣ**

אזהרה

אזהרה

אזהרה: אתה נמצא במצב העלול לגרום לפציעה. לפני שתעבוד עם ציוד מודע לסכנות הכרוכות במעגלים חשמליים ולהכיר את הנהלים המקובלים: מש במספר ההוראה המסופק בסופה של כל אזהרה כד לאתר את התרגום מתורגמות שמצורפות להתקן.



**Opomena**      **ВАЖНИ БЕЗБЕДНОСНИ НАПАТСТВИЈА**  
Симболот за предупредување значи опасност. Се наоѓате во ситуација што може да предизвика телесни повреди. Пред да работите со опремата, бидете свесни за ризикот што постои кај електричните кола и треба да ги познавате стандардните постапки за спречување на несреќни случаи. Искористете го бројот на изјавата што се наоѓа на крајот на секое предупредување за да го најдете неговиот период во преведените безбедносни предупредувања што се испорачани со уредот.  
**ЧУВАЈТЕ ГИ ОВИЕ НАПАТСТВИЈА**

**Ostrzeżenie**      **WAŻNE INSTRUKCJE DOTYCZĄCE BEZPIECZEŃSTWA**  
**Ten symbol ostrzeżenia oznacza niebezpieczeństwo. Zachodzi sytuacja, która może powodować obrażenia ciała. Przed przystąpieniem do prac przy urządzeniach należy zapoznać się z zagrożeniami związanymi z układami elektrycznymi oraz ze standardowymi środkami zapobiegania wypadkom. Na końcu każdego ostrzeżenia podano numer, na podstawie którego można odszukać tłumaczenie tego ostrzeżenia w dołączonym do urządzenia dokumencie z tłumaczeniami ostrzeżeń.**

**NINIEJSZE INSTRUKCJE NALEŻY ZACHOWAĆ**

**Upozornenie**      **DŮLEŽITÉ BEZPEČNOSTNÉ POKYNY**  
**Tento varovný symbol označuje nebezpečenstvo. Nachádzate sa v situácii s nebezpečenstvom úrazu. Pred prácou na akomkoľvek vybavení si uvedomte nebezpečenstvo súvisiace s elektrickými obvodmi a oboznámte sa so štandardnými opatreniami na predchádzanie úrazom. Podľa čísla na konci každého upozornenia vyhľadajte jeho preklad v preložených bezpečnostných upozorneniach, ktoré sú priložené k zariadeniu.**

**USCHOVAJTE SI TENTO NÁVOD**

## Opozorilo POMEMBNI VARNOSTNI NAPOTKI

Ta opozorilni simbol pomeni nevarnost. Nahajate se v situaciji, kjer lahko pride do telesnih poškodb. Preden pričnete z delom na napravi, se morate zavedati nevarnosti udara električnega toka, ter tudi poznati preventivne ukrepe za preprečevanje takšnih nevarnosti. Uporabite obrazložitevno številko na koncu posameznega opozorila, da najdete opis nevarnosti v priloženem varnostnem priročniku.

### SHRANITE TE NAPOTKE!

#### 警告

#### 重要安全性指示

此警告符號代表危險，表示可能造成人身傷害。使用任何設備前，請留心電路相關危險，並熟悉避免意外的標準作法。您可以使用每項警告後的聲明編號，查詢本裝置隨附之安全性警告譯文中的翻譯。

請妥善保留此指示

## Commands

Table 1 describes the syntax used with the commands in this document.

**Table 1**      **Command Syntax Guide**

Convention	Description
<b>boldface</b>	Commands and keywords.
<i>italic</i>	Command input that is supplied by you.
[   ]	Keywords or arguments that appear within square brackets are optional.
{x   x   x}	A choice of keywords (represented by x) appears in braces separated by vertical bars. You must select one.
^ or Ctrl	Represent the key labeled <i>Control</i> . For example, when you read ^D or <i>Ctrl-D</i> , you should hold down the Control key while you press the D key.
screen font	Examples of information displayed on the screen.

**Table 1**      **Command Syntax Guide (continued)**

Convention	Description
<b>boldface screen font</b>	Examples of information that you must enter.
< >	Nonprinting characters, such as passwords, appear in angled brackets.
[ ]	Default responses to system prompts appear in square brackets.

## Accessibility

This product family uses a command line interface (CLI). The CLI is 508 conformant since it is text based and relies on a keyboard for navigation. All functions of the router can be configured and monitored through the CLI.

To view Cisco accessibility guidelines and product adherence, see Cisco Accessibility Products at the following URL:

<http://www.cisco.com/web/about/responsibility/accessibility/products>

## Obtaining Documentation

Cisco documentation and additional literature are available on Cisco.com. Cisco also provides several ways to obtain technical assistance and other technical resources. These sections explain how to obtain technical information from Cisco Systems.

## Cisco.com

You can access the most current Cisco documentation at this URL:

<http://www.cisco.com/techsupport>

You can access the Cisco website at this URL:

<http://www.cisco.com>

You can access international Cisco websites at this URL:

[http://www.cisco.com/public/countries\\_languages.shtml](http://www.cisco.com/public/countries_languages.shtml)

## Product Documentation DVD

The Product Documentation DVD is a comprehensive library of technical product documentation on a portable medium. The DVD enables you to access multiple versions of installation, configuration, and command guides for Cisco hardware and software products. With the DVD, you have access to the same HTML documentation that is found on the Cisco website without being connected to the Internet. Certain products also have .PDF versions of the documentation available.

The Product Documentation DVD is available as a single unit or as a subscription. Registered Cisco.com users (Cisco direct customers) can order a Product Documentation DVD (product number DOC-DOCDVD= or DOC-DOCDVD=SUB) from Cisco Marketplace at this URL:

<http://www.cisco.com/go/marketplace/>

## Ordering Documentation

Registered Cisco.com users may order Cisco documentation at the Product Documentation Store in the Cisco Marketplace at this URL:

<http://www.cisco.com/go/marketplace/>

Nonregistered Cisco.com users can order technical documentation from 8:00 a.m. to 5:00 p.m. (0800 to 1700) PDT by calling 1 866 463-3487 in the United States and Canada, or elsewhere by calling 011 408 519-5055. You can also order documentation by e-mail at [tech-doc-store-mkpl@external.cisco.com](mailto:tech-doc-store-mkpl@external.cisco.com) or by fax at 1 408 519-5001 in the United States and Canada, or elsewhere at 011 408 519-5001.

# Documentation Feedback

You can rate and provide feedback about Cisco technical documents by completing the online feedback form that appears with the technical documents on Cisco.com.

You can submit comments about Cisco documentation by using the response card (if present) behind the front cover of your document or by writing to the following address:

Cisco Systems  
Attn: Customer Document Ordering  
170 West Tasman Drive  
San Jose, CA 95134-9883

We appreciate your comments.

# Cisco Product Security Overview

Cisco provides a free online Security Vulnerability Policy portal at this URL:

[http://www.cisco.com/en/US/products/products\\_security\\_vulnerability\\_policy.html](http://www.cisco.com/en/US/products/products_security_vulnerability_policy.html)

From this site, you will find information about how to:

- Report security vulnerabilities in Cisco products.
- Obtain assistance with security incidents that involve Cisco products.
- Register to receive security information from Cisco.

A current list of security advisories, security notices, and security responses for Cisco products is available at this URL:

<http://www.cisco.com/go/psirt>

To see security advisories, security notices, and security responses as they are updated in real time, you can subscribe to the Product Security Incident Response Team Really Simple Syndication (PSIRT RSS) feed. Information about how to subscribe to the PSIRT RSS feed is found at this URL:

[http://www.cisco.com/en/US/products/products\\_psirt\\_rss\\_feed.html](http://www.cisco.com/en/US/products/products_psirt_rss_feed.html)

## Reporting Security Problems in Cisco Products

Cisco is committed to delivering secure products. We test our products internally before we release them, and we strive to correct all vulnerabilities quickly. If you think that you have identified a vulnerability in a Cisco product, contact PSIRT:

- For Emergencies only—[security-alert@cisco.com](mailto:security-alert@cisco.com)

An emergency is either a condition in which a system is under active attack or a condition for which a severe and urgent security vulnerability should be reported. All other conditions are considered nonemergencies.

- For Nonemergencies—[psirt@cisco.com](mailto:psirt@cisco.com)

In an emergency, you can also reach PSIRT by telephone:

- 1 877 228-7302
- 1 408 525-6532



### Tip

---

We encourage you to use Pretty Good Privacy (PGP) or a compatible product (for example, GnuPG) to encrypt any sensitive information that you send to Cisco. PSIRT can work with information that has been encrypted with PGP versions 2.x through 9.x.

Never use a revoked or an expired encryption key. The correct public key to use in your correspondence with PSIRT is the one linked in the Contact Summary section of the Security Vulnerability Policy page at this URL:

[http://www.cisco.com/en/US/products/products\\_security\\_vulnerability\\_policy.html](http://www.cisco.com/en/US/products/products_security_vulnerability_policy.html)

The link on this page has the current PGP key ID in use.

If you do not have or use PGP, contact PSIRT at the aforementioned e-mail addresses or phone numbers before sending any sensitive material to find other means of encrypting the data.

---

# Obtaining Technical Assistance

Cisco Technical Support provides 24-hour-a-day award-winning technical assistance. The Cisco Technical Support & Documentation website on Cisco.com features extensive online support resources. In addition, if you have a valid Cisco service contract, Cisco Technical Assistance Center (TAC) engineers provide telephone support. If you do not have a valid Cisco service contract, contact your reseller.

## Cisco Technical Support & Documentation Website

The Cisco Technical Support & Documentation website provides online documents and tools for troubleshooting and resolving technical issues with Cisco products and technologies. The website is available 24 hours a day, at this URL:

<http://www.cisco.com/techsupport>

Access to all tools on the Cisco Technical Support & Documentation website requires a Cisco.com user ID and password. If you have a valid service contract but do not have a user ID or password, you can register at this URL:

<http://tools.cisco.com/RPF/register/register.do>

## Cisco Product Identification Tool

Use the Cisco Product Identification (CPI) tool to locate your product serial number before submitting a web or phone request for service. You can access the CPI tool from the Cisco Technical Support & Documentation website by clicking the **Tools & Resources** link under Documentation & Tools. Choose **Cisco Product Identification Tool** from the Alphabetical Index drop-down list, or click the **Cisco Product Identification Tool** link under Alerts & RMAs. The CPI tool offers three search options: by product ID or model name; by tree view; or for certain products, by copying and pasting **show** command output. Search results show an illustration of your product with the serial number label location highlighted. Locate the serial number label on your product and record the information before placing a service call.

## Submitting a Service Request

Using the online TAC Service Request Tool is the fastest way to open S3 and S4 service requests. (S3 and S4 service requests are those in which your network is minimally impaired or for which you require product information.) After you describe your situation, the TAC Service Request Tool provides recommended solutions. If your issue is not resolved using the recommended resources, your service request is assigned to a Cisco engineer. The TAC Service Request Tool is located at this URL:

<http://www.cisco.com/techsupport/servicerequest>

For S1 or S2 service requests, or if you do not have Internet access, contact the Cisco TAC by telephone. (S1 or S2 service requests are those in which your production network is down or severely degraded.) Cisco engineers are assigned immediately to S1 and S2 service requests to help keep your business operations running smoothly.

To open a service request by telephone, use one of the following numbers:

Asia-Pacific: +61 2 8446 7411 (Australia: 1 800 805 227)

EMEA: +32 2 704 55 55

USA: 1 800 553-2447

For a complete list of Cisco TAC contacts, go to this URL:

<http://www.cisco.com/techsupport/contacts>

## Definitions of Service Request Severity

To ensure that all service requests are reported in a standard format, Cisco has established severity definitions.

**Severity 1 (S1)**—An existing network is down, or there is a critical impact to your business operations. You and Cisco will commit all necessary resources around the clock to resolve the situation.

**Severity 2 (S2)**—Operation of an existing network is severely degraded, or significant aspects of your business operations are negatively affected by inadequate performance of Cisco products. You and Cisco will commit full-time resources during normal business hours to resolve the situation.



Severity 3 (S3)—Operational performance of the network is impaired, while most business operations remain functional. You and Cisco will commit resources during normal business hours to restore service to satisfactory levels.

Severity 4 (S4)—You require information or assistance with Cisco product capabilities, installation, or configuration. There is little or no effect on your business operations.

## Obtaining Additional Publications and Information

Information about Cisco products, technologies, and network solutions is available from various online and printed sources.

- The *Cisco Product Quick Reference Guide* is a handy, compact reference tool that includes brief product overviews, key features, sample part numbers, and abbreviated technical specifications for many Cisco products that are sold through channel partners. It is updated twice a year and includes the latest Cisco offerings. To order and find out more about the Cisco Product Quick Reference Guide, go to this URL:

<http://www.cisco.com/go/guide>

- Cisco Marketplace provides a variety of Cisco books, reference guides, documentation, and logo merchandise. Visit Cisco Marketplace, the company store, at this URL:

<http://www.cisco.com/go/marketplace/>

- *Cisco Press* publishes a wide range of general networking, training and certification titles. Both new and experienced users will benefit from these publications. For current Cisco Press titles and other information, go to Cisco Press at this URL:

<http://www.ciscopress.com>

- *Packet* magazine is the Cisco Systems technical user magazine for maximizing Internet and networking investments. Each quarter, Packet delivers coverage of the latest industry trends, technology breakthroughs, and Cisco products and solutions, as well as network deployment and troubleshooting tips, configuration examples, customer case studies, certification and training information, and links to scores of in-depth online resources. You can access Packet magazine at this URL:

<http://www.cisco.com/packet>

- *iQ Magazine* is the quarterly publication from Cisco Systems designed to help growing companies learn how they can use technology to increase revenue, streamline their business, and expand services. The publication identifies the challenges facing these companies and the technologies to help solve them, using real-world case studies and business strategies to help readers make sound technology investment decisions. You can access iQ Magazine at this URL:

<http://www.cisco.com/go/iqmagazine>

or view the digital edition at this URL:

<http://ciscoiq.texterity.com/ciscoiq/sample/>

- *Internet Protocol Journal* is a quarterly journal published by Cisco Systems for engineering professionals involved in designing, developing, and operating public and private internets and intranets. You can access the Internet Protocol Journal at this URL:

<http://www.cisco.com/ipj>

- Networking products offered by Cisco Systems, as well as customer support services, can be obtained at this URL:

<http://www.cisco.com/en/US/products/index.html>

- Networking Professionals Connection is an interactive website for networking professionals to share questions, suggestions, and information about networking products and technologies with Cisco experts and other networking professionals. Join a discussion at this URL:

<http://www.cisco.com/discuss/networking>

- World-class networking training is available from Cisco. You can view current offerings at this URL:

<http://www.cisco.com/en/US/learning/index.html>



# Overview

---

This chapter introduces the Cisco 815 integrated services router, also referred to in this guide as *the router*, and covers the following topics:

- [Key Features](#)
- [Back Panel Ports and LEDs](#)
- [Front Panel LEDs](#)
- [Router Memory](#)
- [Unpacking the Router](#)

## Key Features

The Cisco 815 integrated services router (see [Figure 1-1](#)) is a small, modular desktop router that provides an integrated cable solution. The Cisco 815 integrated services router communicates over a cable hybrid fiber coaxial (HFC) network for office-to-Internet connectivity or branch-to-branch connectivity. The Cisco cable modem high-speed WAN interface cards (HWICs) are installed in the router as a fixed configuration for one HWIC full-feature cable modem high-speed interaction, including quality of service (QoS) functionality.

Figure 1-1 Cisco 815 Integrated Services Router

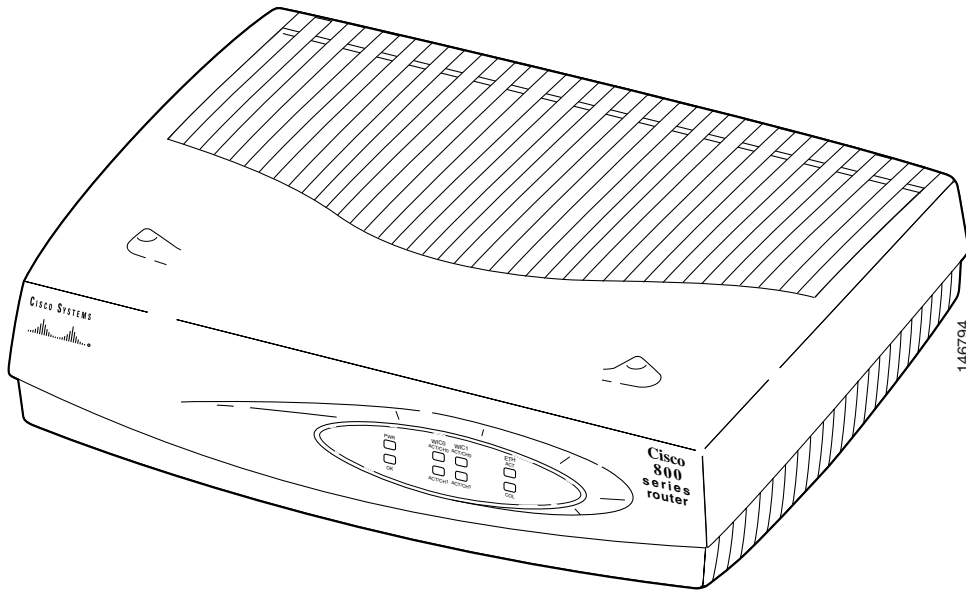

Table 1-1 Key Features

Feature	Description
One Fast Ethernet (10/100BASE-TX) port	<ul style="list-style-type: none"> <li>Operates in full- or half-duplex mode (with manual override available).</li> <li>Supports autosensing for 10- or 100-Mbps operation.</li> <li>Supports IEEE 802.1Q VLAN encapsulation.</li> </ul>
Two Cisco WAN interface card (WIC) slots	<ul style="list-style-type: none"> <li>Supports a WIC-4ESW and HWIC-CABLE-D-2.</li> </ul> <p><b>Note</b> These slots are fixed and are not field replaceable.<sup>1</sup></p>
Console port	Supports router configuration and management with a directly-connected terminal or PC. Supports up to 115.2 kbps.
Auxiliary port	Supports modem connection to the router, which can be configured and managed from a remote location. Supports up to 115.2 kbps.
SNMP support	Router can be managed over a network using Simple Network Management Protocol (SNMP).

**Table 1-1** Key Features (continued)

Feature	Description
AutoInstall support	Configuration files can be easily downloaded to the router over a WAN connection.
Kensington security slot	Router can be secured to a desktop or other surface using Kensington lockdown equipment.
Support for Cisco IOS software features	Supports IP, IPX, AppleTalk, IBM, Open Shortest Path First (OSPF) Protocol, NetWare Link Services Protocol (NLSP), Resource Reservation Protocol (RSVP), encryption, network address translation, and the Cisco IOS Firewall Feature Set.

1. The HWIC-CABLE-D-2 operates only in WIC mode with 8-Mbps downstream throughput.

## Product Serial Number Location

The serial number label for the Cisco 815 integrated services router is located on the rear of the chassis, to the right of the power switch. (See [Figure 1-2](#))

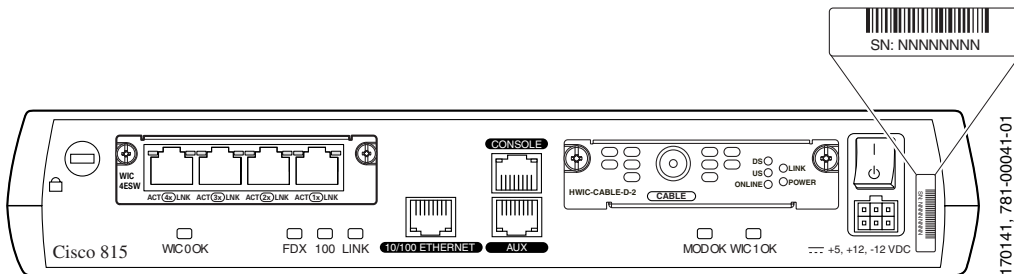
**Figure 1-2** Serial Number Location on the Cisco 815 Router

170141, 781-00041-01

# Back Panel Ports and LEDs

This section describes the router back panel ports and LEDs, which are shown and identified in [Figure 1-3](#) and are described in [Table 1-2](#) and [Table 1-3](#). [Figure 1-4](#) shows a closer view of the WIC-4ESW module, which is installed in the WIC 0 slot on the router. [Figure 1-5](#) shows a closer view of the HWIC-CABLE-D-2 module, which is installed in the WIC 1 slot on the router.

**Figure 1-3 Back Panel Ports and LEDs**

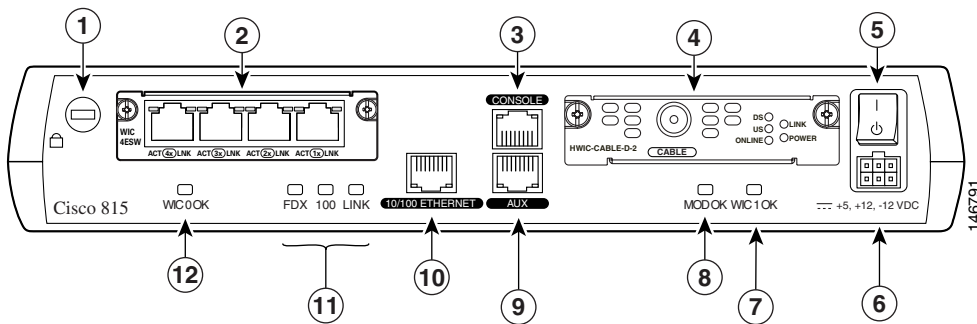

1	Kensington-compatible locking socket	7	WIC 1 OK LED
2	WIC 0 slot	8	Module OK LED
3	Console port	9	Auxiliary port
4	WIC 1 slot	10	10/100-Mbps Fast Ethernet port
5	Power switch	11	Full duplex (FDX), 100, Link LEDs
6	Power socket	12	WIC 0 OK LED

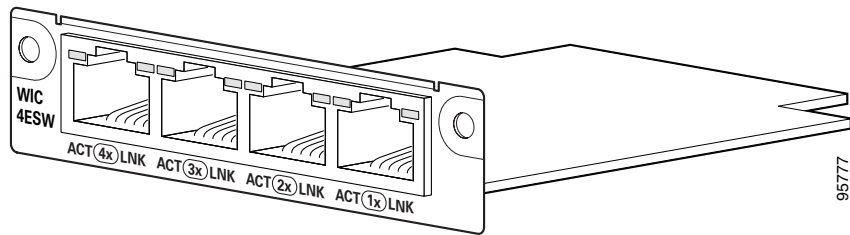
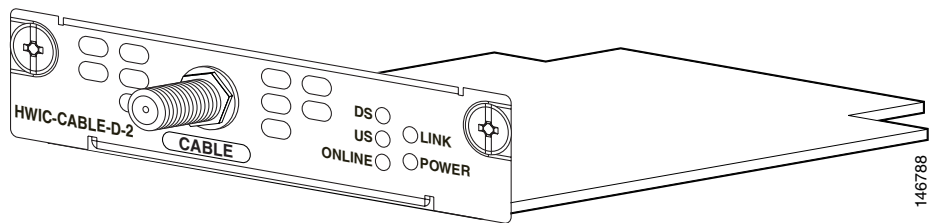
**Figure 1-4** WIC-4ESW**Figure 1-5** HWIC-CABLE-D-2**Table 1-2** Back Panel Connectors

Connector/Slot	Label/Color	Description
Ethernet port	10/100 ETHERNET (yellow)	Connects the router to the local Ethernet network. This port autosenses the speed (10 Mbps or 100 Mbps) and duplex mode (full- or half-) of the device to which it is connected, and then operates at the same speed and in the same duplex mode.
Auxiliary port	AUX (black)	Connects to a modem for remote configuration using Cisco IOS software.
Console port	CONSOLE (blue)	Connects to a terminal or PC for local configuration using Cisco IOS software.
WIC-4ESW (WIC 0)	No label	Supports interface card with four 10/100-BASE-TX Ethernet switchports. See <a href="#">Figure 1-4</a> .
HWIC-CABLE-D-2 (WIC 1)	No label	Supports one Cisco cable WIC. See <a href="#">Figure 1-5</a> .

Use the back panel LEDs during router installation to confirm that you have correctly connected all the cables to the router.

**Table 1-3**      **Back Panel LEDs**

LED Label	Color	Description
WIC0 OK	Green	On when the WIC is correctly installed in the card slot.  There are 2 LEDs associated with the WIC-4ESW: The right LED, which is labeled LNK, and the left LED, which is labeled ACT. The LNK (physical layer link) LED is on when the Cisco IOS software recognizes the switch and the connection is up. The ACT (activity) LED indicates that data is being transmitted or received on the slot.
FDX	Green	On solid—Ethernet port is operating in full-duplex mode. Off—Ethernet port is operating in half-duplex mode.
100	Green	On solid—Ethernet port is operating at 100 Mbps. Off—Ethernet port is operating at 10 Mbps.
LINK	Green	On when the Ethernet link is up.
MOD OK	Green	On when the VPN hardware encryption module is installed and recognized by the Cisco IOS software.
WIC1 OK	Green	On when the WIC is correctly installed in the card slot.

## Front Panel LEDs

Use the router front panel LEDs to determine network activity and status on the Ethernet port and on the WIC ports. The front panel LEDs are shown in [Figure 1-6](#) and described in [Table 1-4](#).



Figure 1-6 Front Panel LEDs

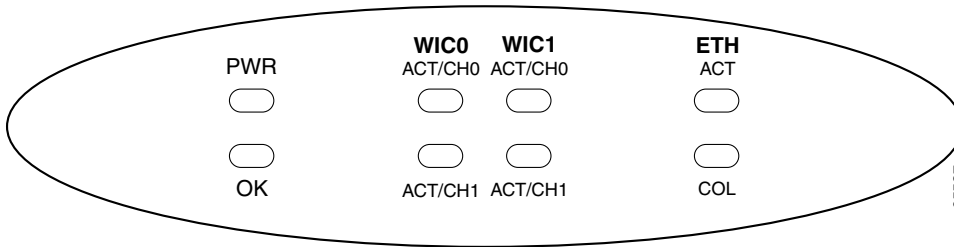

Table 1-4 Front Panel LEDs

LED Label	Color	Description
PWR	Green	On means that DC power is being supplied to the router.
OK	Green	On means that the router has successfully booted up and the software is functional. This LED blinks during the power-on self-test (POST).  See the section “OK LED Diagnostics” in Chapter 3, “Troubleshooting,” for information on how to use this LED for router diagnostics.
WIC0	N/A	N/A.
ACT/CH0	Green	Blinks when data is being sent to or received from the port on the card in the WIC 0 slot.  2-port serial cards—Blinks when data is being sent to or received from the first port on the 2-port card in the WIC 0 slot.
ACT/CH1	Green	Remains off.  2-port serial cards—Blinks when data is being sent to or received from the second port on the 2-port card in the WIC 0 slot.
WIC1	N/A	N/A.
ACT/CH0	Green	Blinks when data is being sent to or received from the port on the card in the WIC 1 slot.  2-port serial cards—Blinks when data is being sent to or received from the first port on the 2-port card in the WIC 1 slot.
ACT/CH1	Green	Remains off.

Table 1-4 Front Panel LEDs (continued)

LED Label	Color	Description
ETH	N/A	2-port serial cards—Blinks when data is being sent to or received from the second port on the 2-port card in the WIC 1 slot.
ACT	Green	Blinks when there is network activity on the Ethernet port.
COL	Yellow	Blinks when there are packet collisions on the local Ethernet network.

## Router Memory

This section describes the types of memory stored in the router and how to find out how much of each type of memory is stored in the router.

For instruction on how to upgrade memory in the router, see [Appendix C, “Installing and Upgrading Memory and Virtual Private Network Modules.”](#)

## Types of Memory

The Cisco 815 integrated services router has the following types of memory:

- Dynamic random-access memory (DRAM)—This is the main storage memory for the router. DRAM is also called *working storage*. It contains the dynamic configuration information. The DRAM in the Cisco 815 integrated services router stores a working copy of the Cisco IOS software, dynamic configuration information, and routing table information.
- Nonvolatile random-access memory (NVRAM)—This type of memory contains a backup copy of the router configuration. If the power is lost or the router is turned off, this backup copy enables the router to return to operation without reconfiguration.
- Flash memory—This special kind of erasable, programmable memory contains a copy of the Cisco IOS software. The flash memory structure can store multiple copies of the Cisco IOS software. You can load a new level of the operating system in every router in your network and then, when convenient, upgrade the whole network to the new level.

## Amounts of Memory

The Cisco 815 integrated services router supports a maximum of 32 MB of flash memory and 128 MB of DRAM. Use the **show version** command to see how much DRAM, NVRAM, and flash memory is stored in your router. The following example of output for the **show version** command shows the amount of memory in this router:

```
815# show version
Cisco IOS Software, C815 Software (C815-IPBASE-M), Version
12.4(5.13.5)PIA5 ENGINEERING WEEKLY BUILD, synced to haw_t_pi4_abu
HAW_T_PI4_ABU_5_13_1_PIA4
Copyright (c) 1986-2006 by Cisco Systems, Inc.
Compiled Wed 22-Mar-06 18:07 by ealyon

ROM: System Bootstrap, Version 12.2(20060221:032620)
[yiye-after815rmon 101], DEVELOPMENT SOFTWARE

815B uptime is 6 days, 14 hours, 41 minutes
System returned to ROM by reload at 22:59:26 PST Mon Apr 24 2006
System restarted at 23:01:51 PST Mon Apr 24 2006
System image file is "flash:c815-ipbase-mz.124-5.13.5.PIA5"

Cisco 815 (MPC860P) processor (revision 0x500) with 59569K/5967K bytes
of memory.
Processor board ID FOC09250KK8 (1061493493), with hardware revision
0000
MPC860P processor: part number 5, mask 2
1 Ethernet interface
5 FastEthernet interfaces
1 Cable Modem interface
32K bytes of NVRAM.
32768K bytes of processor board System flash (Read/Write)
Configuration register is 0x2102
815#
```

# Unpacking the Router

Figure 1-7 lists the items that come with your router. All these items are in the accessory kit that came with your router.

**Figure 1-7** Items Included with the Cisco 815 Integrated Services Router

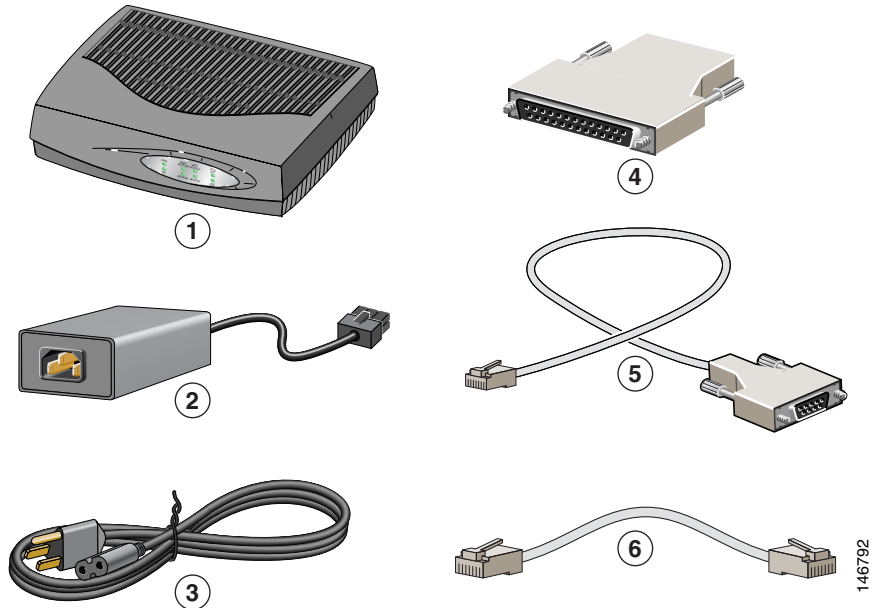

1	Cisco 815 integrated services router	4	DB-9-to-DB-25 adapter
2	Power supply	5	Console cable (RJ-45 to DB-9)
3	Power cable	6	Ethernet cable



# Installation

---

This chapter provides procedures for installing the Cisco 815 integrated services router and includes the following sections:

- [Before Installing the Router](#)
- [Connecting the Router to Your Local Network](#)
- [Connecting Power to the Router](#)
- [Verifying Your Installation](#)
- [Optional Installation Procedures](#)

## Before Installing the Router

The Cisco 815 integrated services router is shipped ready for desktop mounting. Before you connect it to the power and network, simply set the router on a desktop, shelf, or other flat surface.

Be sure to read the safety information in the [Regulatory Compliance and Safety Information for Cisco 800 Series and SOHO Series Routers](#) document online.



**Warning**

---

**Read the installation instructions before you connect the system to its power source.**

---

**Warning**

Before working on equipment that is connected to power lines, remove jewelry (including rings, necklaces, and watches). Metal objects will heat up when connected to power and ground and can cause serious burns or weld the metal object to the terminals. (To see translated versions of this warning, refer to the *Regulatory Compliance and Safety Information for Cisco 800 Series and SOHO Series Routers* document that came with the router.)

**Warning**

Do not work on the system or connect or disconnect cables during periods of lightning activity.

**Caution**

Do not place anything on top of the router that weighs more than 10 pounds (4.5 kg). Excessive weight on top of the router could damage the chassis.

**Caution**

There are no field-replaceable parts inside the router. Do not open the router enclosure to replace parts.

**Caution**

To prevent damage to the chassis, never attempt to lift or tilt the chassis by the plastic panel on the front. Always hold the chassis by the metal body.

## Connecting the Router to Your Local Network

The Cisco 815 integrated services router is connected to your local Ethernet network through the yellow 10/100 Ethernet port. You must provide the following items for this connection:

- A straight-through, RJ-45-to-RJ-45, Ethernet cable
- A 10/100-Mbps Ethernet hub or switch

**Caution**

Do not connect a WAN cable to the card until you have completed the installation procedure.

**Note**

For details about specific WAN interface cards (WICs), connecting the card to the WAN line, and configuring the interface with Cisco IOS software, see the [Cisco Interface Cards Hardware Installation Guide](#).

**Warning**

**The ports labeled 10/100 ETHERNET and CONSOLE are safety extra-low voltage (SELV) circuits. SELV circuits should only be connected to other SELV circuits. Because BRI circuits are treated like telephone-network voltage, avoid connecting the SELV circuits to the telephone network voltage (TNV) circuits. (To see translated versions of this warning, refer to the *Regulatory Compliance and Safety Information for Cisco 800 Series and SOHO Series Routers* document that came with the router.)**

Follow these steps to connect the router to the local network:

**Step 1**

Connect one end of the cable to the yellow Ethernet port (labeled 10/100 ETHERNET) on the back panel of the router, as shown in [Figure 2-1](#).

Figure 2-1 Connecting the Router to the Local Network

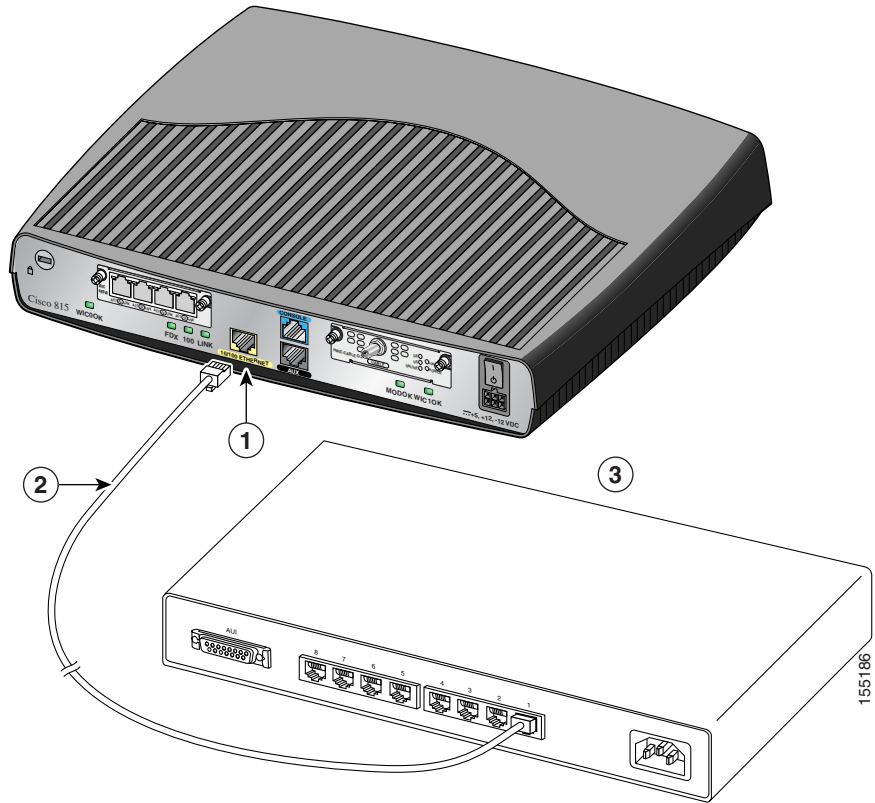

1	10/100 Ethernet port on the Cisco 815 integrated services router	3	Ethernet hub or switch
2	Straight-through Ethernet cable		

**Step 2** Connect the other end of the cable to a network port on the hub or switch.



# Connecting Power to the Router

Read the following warnings before connecting the router to power.



**Warning**

**The power supply is designed to work with TN power systems.**



**Warning**

**This equipment is intended to be grounded. Ensure that the host is connected to earth ground during normal use.**

Follow these steps to connect power to the router and to turn on the router:

- Step 1** Connect the attached power-supply cord to the power socket (labeled +5, +12, -12 VDC) on the router back panel, as shown in [Figure 2-2](#).

**Figure 2-2** Connecting the Power Supply

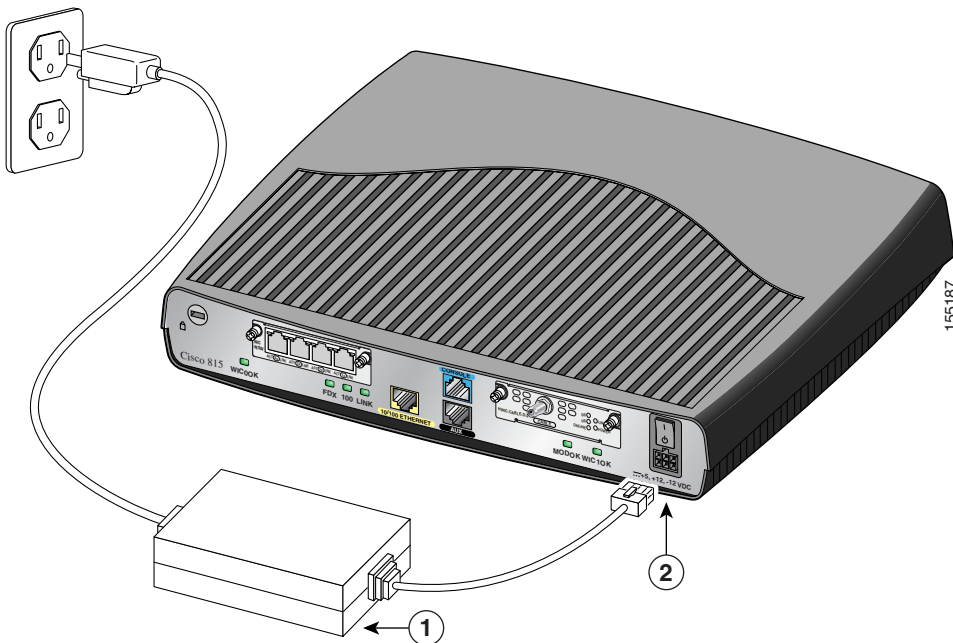

<b>1</b>	Power supply	<b>2</b>	Power socket
----------	--------------	----------	--------------

- Step 2** Connect one end of the separate power cord to the socket on the power supply.
- Step 3** Connect the other end of the separate power cord to a power outlet.
- Step 4** Press the router power switch to ON ( I ).
- Step 5** Confirm that the router has power by checking that the PWR LED on the front panel is on.
- 

## Verifying Your Installation

You can verify that you have correctly installed the router by checking the following LEDs:

- PWR (front panel)—On when power is being supplied to the router.
- OK (front panel)—On when the router software is loaded and functional. Blinking indicates that the router is performing a power-on self-test (POST).
- WIC0/WIC1 OK (back panel)—On when the WIC is correctly installed in the corresponding WIC slot.
- ETH ACT (front panel)—Blinking when there is network traffic on the local 10/100 Ethernet LAN.
- WIC0 ACT or WIC1 ACT (front panel)—Varies, depending on the WIC installed. See [Table 1-4](#) in [Chapter 1](#), “Overview.”
- LINK (back panel)—On when the router is correctly connected to the local Ethernet LAN through the 10/100 ETHERNET port.
- MOD OK (back panel)—On when the VPN hardware encryption module is installed and recognized by the Cisco IOS software.

# Optional Installation Procedures

This section describes some installation procedures that you might or might not use, depending on your site and on how you are configuring the router. This section describes the following procedures:

- [Connecting a PC](#)
- [Connecting a Modem](#)
- [Stacking the Router](#)
- [Unstacking the Router](#)

## Connecting a PC

If you want to use the Cisco IOS command-line interface to configure the router, you must connect the router console port to a terminal or PC. The cable and adapter required for this connection are included with the router.

If you want to use a PC to configure the router, you need to make sure that the PC has some type of terminal emulation software installed. The software should be configured with the following parameters: 9600 baud, 8 data bits, no parity bits, 1 stop bit.

Follow these steps to connect the router to a terminal or PC:

- 
- Step 1** Connect the blue console cable to the blue console port on the back of the router, as shown in [Figure 2-3](#).

Figure 2-3 Connecting the Console Cable to the Router

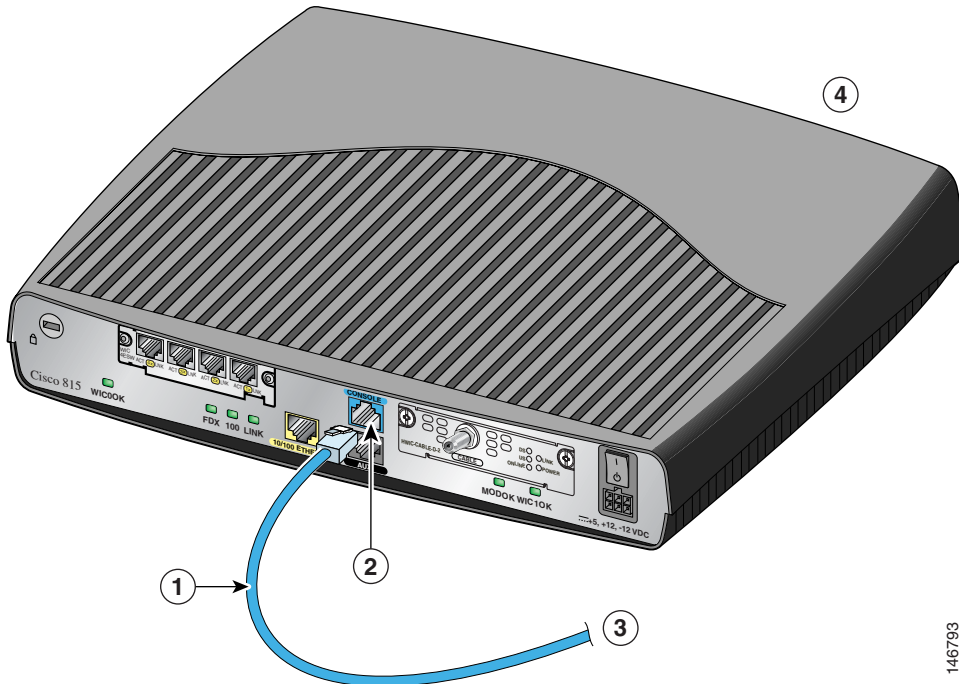

146793

1	Blue console cable	3	To PC or terminal
2	Console port	4	Cisco 815 integrated services router

**Step 2** Connect the DB-9 end of the console cable to the console port (also called the *serial port*) on your PC. If this adapter does not fit your PC console port, you must provide an adapter that fits.

## Connecting a Modem

When a modem is connected to the auxiliary port, a remote user can dial in to the router and configure it. You can use the console cable provided in the accessory kit.

Follow these steps to connect a modem to the router, using the console cable:

- Step 1** Connect the RJ-45 end of the cable to the black AUX port on the back of the router, as shown in [Figure 2-4](#).

**Figure 2-4** Connecting a Modem to the Router

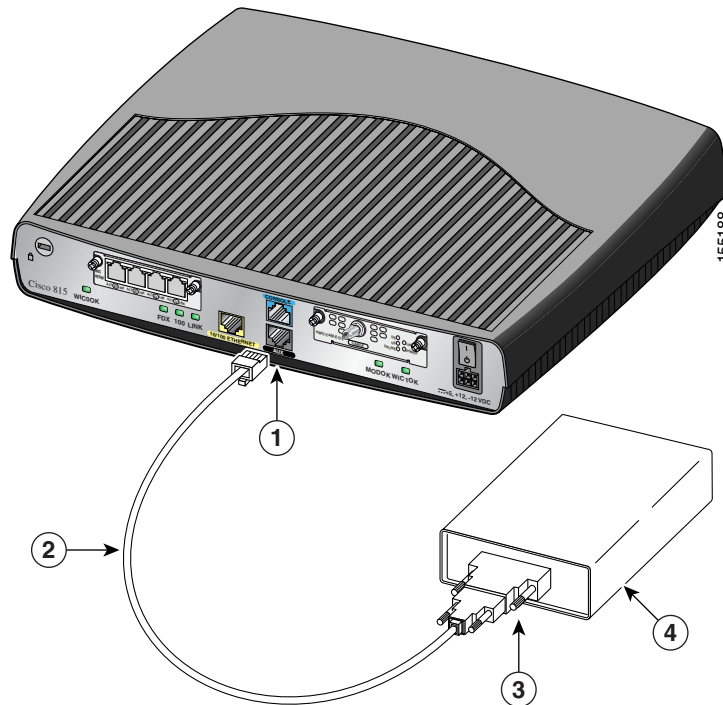

1	AUX port (RJ-45)	3	DB-9-to-DB-25 adapter
2	Console cable	4	Modem

- Step 2** Connect the DB-9 end of the cable to the DB-9 end of the DB-9-to-DB-25 adapter.
- Step 3** Connect the DB-25 end of the adapter to the modem.
- 

## Stacking the Router

You can stack one Cisco 815 integrated services router in a four-device stack, along with other Cisco products designed for stacking with the router. Using a stacking clip and fastener, you can stack each device directly on top of another device.

**Note**

---

The Cisco 815 integrated services router is not shipped with the stacking equipment described in this section; however, the equipment is included with all other Cisco products that are designed to be stacked.

---

Other Cisco products designed to be stacked with the router comes with a stacking clip and a fastener for keeping the multiple devices together in a stack. Before you stack the devices, assemble the clip and fastener as shown in [Figure 2-5](#).

**Figure 2-5** Assembling Stacking Clip and Fastener

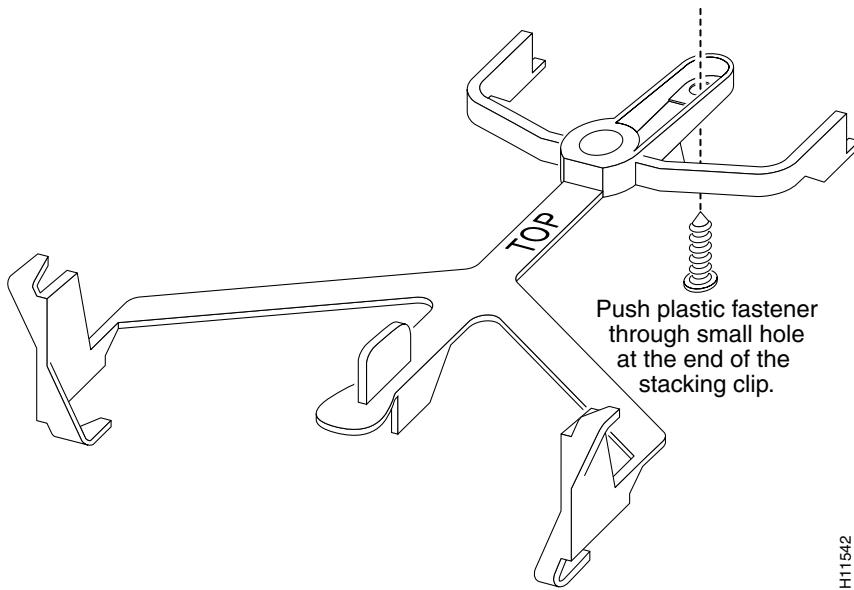

After assembling the clip and fastener, follow these steps to stack the router with another device:

- 
- Step 1** Place the clip on top of the lower device, as shown in [Figure 2-6](#). Slide the clip forward so that the front tabs slide into the vent slots. Make sure that the back hooks fit over the edge of the lower device.

Figure 2-6 Stacking the Router (Back View)

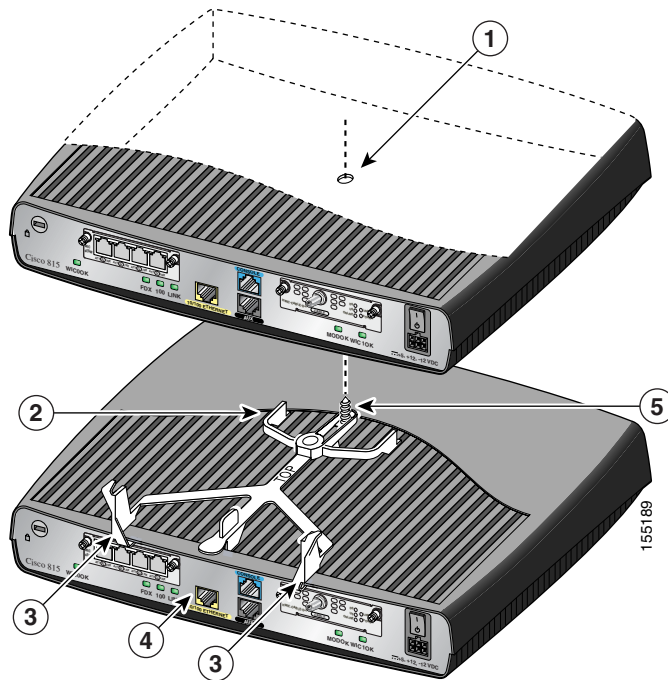

1	Slot on bottom of router (see also #5)	4	Back panel of lower hub
2	Front tabs	5	Plastic fastener, which fits into slot on bottom of router (see #1)
3	Back hooks		

- Step 2** Position the router onto the clip so that the back hooks fit over the edge of the router.
- Step 3** Position the plastic fastener into the slot on the bottom of the router.
- Step 4** Snap the router onto the clip by pushing it down.



## Unstacking the Router

Follow these steps to unstack the router from another device:

- Step 1** Press up on the tab over the center of the lower device to release the clip from the vent, as shown in [Figure 2-7](#).

**Figure 2-7** Unstacking the Router

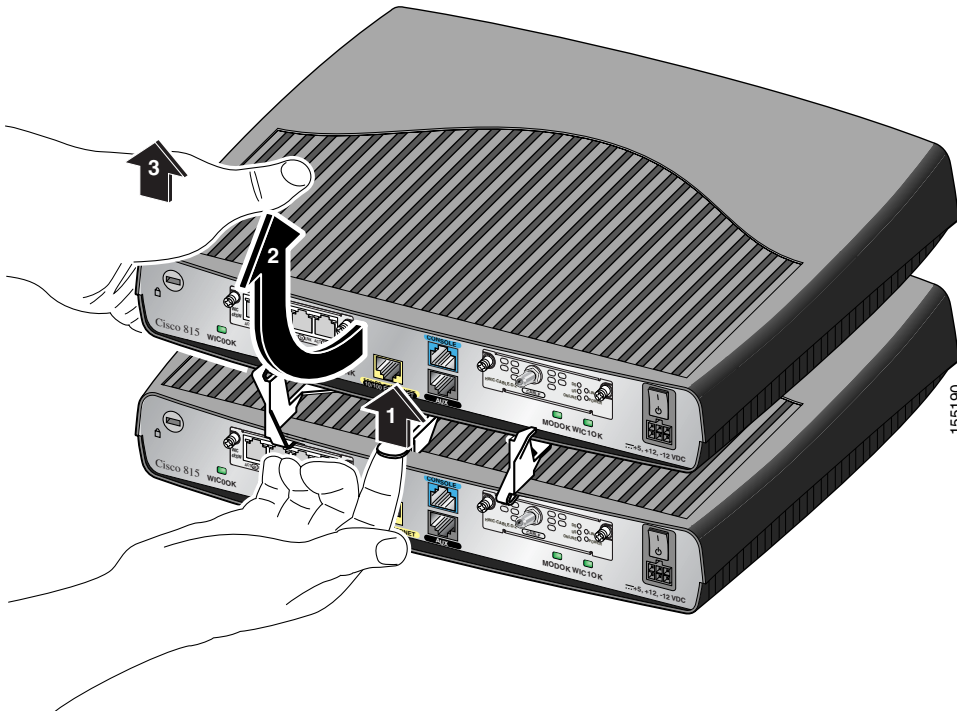

- Step 2** Slide the clip and router toward you.
- Step 3** Use both hands to lift the router and the stacking clip off the lower device. Afterward, remove the clip from the bottom of the router.





# Troubleshooting

---

Use the information in this chapter to help isolate problems you might encounter with the Cisco 815 integrated services router or to rule out the router as the source of the problem.

This appendix contains the following sections:

- [Contacting Your Cisco Reseller](#)
- [Recovering a Lost Password](#)
- [Problem Solving](#)

## Contacting Your Cisco Reseller

If you cannot locate the source of a problem, contact your local reseller for advice. Before you call, you should have the following information ready:

- Chassis type and serial number
- Maintenance agreement or warranty information
- Type and version number of the Cisco IOS software that is installed on your router
- Date that you received the router
- Brief description of the problem
- Brief description of the steps you have taken to isolate the problem
- Output from the **show tech-support** command

# Recovering a Lost Password

This section describes how to recover a lost enable password and how to enter a new enable secret password.

Password recovery consists of the following major processes:

- [Determining the Configuration Register Value](#)

With this process, you determine the configuration of the router, so that you may restore the configuration after the password is recovered.

- [Resetting the Router](#)

With this process, you reconfigure the router to its initial startup configuration. You then display the enable password, if one is used.

- [Resetting the Password](#)

If you are using an enable secret password, you enter a new password with this process. You then restore the router to its previous configuration.

- [Resetting the Configuration Register Value](#)

If you are using an enable password, you use this process to restore the router to its previous configuration.

**Note**

---

See the “Hot Tips” section on Cisco.com for additional information on replacing enable secret passwords.

---

## Determining the Configuration Register Value

Follow these steps to determine the configuration register value:

- 
- Step 1** Connect an ASCII terminal or a PC that is running a terminal-emulation program to the console port on the router. See the “[Connecting a PC](#)” section in Chapter 2, “[Installation](#).”
  - Step 2** Configure the terminal to operate at 9600 baud, 8 data bits, no parity, 1 stop bit and no flow control.
  - Step 3** Reboot the router by pressing the power switch to the off ( 0 ) position and then to the on ( | ) position.

**Step 4** At the user EXEC prompt (Router>), enter the **show version** command to display the existing configuration register value (shown at the end of this example output):

```
815# show version
Cisco IOS Software, C815 Software (C815-IPBASE-M), Version
12.4(5.13.5)PIA5 ENGINEERING WEEKLY BUILD, synced to haw_t_pi4_abu
HAW_T_PI4_ABU_5_13_1_PIA4
Copyright (c) 1986-2006 by Cisco Systems, Inc.
Compiled Wed 22-Mar-06 18:07 by ealyon

ROM: System Bootstrap, Version 12.2(20060221:032620)
[yiye-after815rmon 101], DEVELOPMENT SOFTWARE

815B uptime is 6 days, 14 hours, 41 minutes
System returned to ROM by reload at 22:59:26 PST Mon Apr 24 2006
System restarted at 23:01:51 PST Mon Apr 24 2006
System image file is "flash:c815-ipbase-mz.124-5.13.5.PIA5"

Cisco 815 (MPC860P) processor (revision 0x500) with 59569K/5967K bytes
of memory.
Processor board ID FOC09250KK8 (1061493493), with hardware revision
0000
MPC860P processor: part number 5, mask 2
1 Ethernet interface
5 FastEthernet interfaces
1 Cable Modem interface
32K bytes of NVRAM.
32768K bytes of processor board System flash (Read/Write)
Configuration register is 0x2102
815#
```

**Step 5** Record the setting of the configuration register.

**Step 6** Record the break setting, as given by bit 8 of the configuration register.

- Break enabled—Bit 8 is set to 0.
  - Break disabled (default setting)—Bit 8 is set to 1.
-

## Resetting the Router

Follow these steps to reset the router:

- 
- Step 1** Do one of the following:
- If break is enabled, go to [Step 2](#).
  - If break is disabled, turn off the router, wait 5 seconds, and turn it on again. Within 60 seconds, press the **Break** key. The terminal displays the ROM monitor prompt. Go to [Step 3](#).



---

**Note** Some terminal keyboards have a key labeled Break. If your keyboard does not have a Break key, refer to the documentation that came with the terminal for instructions on how to send a break. To send a break in Windows HyperTerminal, press **Ctrl-Break**.

---

- Step 2** Send a break. The terminal displays the following prompt:

```
rommon 2>
```

- Step 3** Enter **confreg 0x142** to reset the configuration register:

```
rommon 2> confreg 0x142
```

- Step 4** Initialize the router by entering the **reset** command:

```
rommon 2> reset
```

The router resets, and the configuration register is set to 0x142. The router boots the system image in flash memory and displays the following:

```
--- System Configuration Dialog ---
```

- Step 5** Enter **no** in response to the prompts until the following message is displayed:

```
Press RETURN to get started!
```

- Step 6** Press **Return**. The following prompt appears:

```
Router>
```

- Step 7** Enter the **enable** command to enter privileged EXEC mode. Configuration changes can be made only in this mode.

```
Router> enable
```

The prompt changes to the privileged EXEC prompt:

```
Router#
```

- Step 8** Enter the **show startup-config** command to display an enable password in the configuration file:

```
Router# show startup-config
```

If you are using an enable password, it will appear in the startup configuration. Write down the password and keep the record secure.

If you are using an enable secret password, there will be no enable password in the startup configuration.

- Step 9** Enter the **copy startup-config running-config** command to return to your startup configuration:

```
Router# copy startup-config running-config
```

---

If you are recovering an enable password, skip the next section, “[Resetting the Password](#),” and complete the password recovery process by performing the steps in the “[Resetting the Configuration Register Value](#)” section.

If you are resetting an enable secret password, you will not see it displayed in the **show startup-config** command output. Complete the password recovery process by performing the steps in the “[Resetting the Password](#)” section, which follows.

## Resetting the Password

Follow these steps to reset an enable secret password and restore the configuration of the router:

- 
- Step 1** Enter the **configure terminal** command to enter configuration mode:
- ```
Router# configure terminal
```
- Step 2** Enter the **enable secret** command to reset the enable secret password in the router:
- ```
Router(config)# enable secret <password>
```
- Step 3** Enter the **config-register** command and the original configuration register value that you recorded in [Step 5](#) in the “[Determining the Configuration Register Value](#)” section on page 3-2.
- Step 4** Press **Ctrl-Z** to exit configuration mode.
- ```
Router(config)# Ctrl-Z
```
- Step 5** Save your configuration changes:
- ```
Router# copy running-config startup-config
```
- Step 6** Reboot the router, and enter the enable secret password.
- 

## Resetting the Configuration Register Value

Follow these steps to restore the configuration of the router after you have recovered an enable password:

- 
- Step 1** Enter the **configure terminal** command to enter configuration mode:
- ```
Router# configure terminal
```
- Step 2** Enter the **config-register** command and the original configuration register value that you recorded in [Step 5](#) in the “[Determining the Configuration Register Value](#)” section on page 3-2.



**Step 3** Press **Ctrl-Z** to exit configuration mode:

```
Router (config) # Ctrl-Z
```

**Step 4** Reboot the router, and enter the recovered enable password.

---

## Problem Solving

The key to problem solving is to isolate the problem to a specific subsystem by comparing what the router is doing to what it should be doing.

In problem solving, consider the following subsystems of the router:

- **WICs**—Refer to the LEDs on the cards and the LEDs on the router front panel to help identify a failure. For more information on WAN interface cards (WICs), refer to the *Cisco Interface Cards Hardware Installation Guide*.
- **Cables**—Check all the external cables that connect the router to the network.
- **Power system**—Check the external power source, power cable, router power supply, and circuit breaker. Check for inadequate ventilation or air circulation that might cause overheating.

## OK LED Diagnostics

Use the front panel OK LED to determine any problems with the router. When the router first boots up, it performs a power-on self-test (POST). If the router detects a problem during the POST, the OK LED blinks in different patterns (described in [Table 3-1](#)), depending on the problem. A pattern consists of a specific number of blinks that is repeated until the router is turned off. If the router experiences any of these problems, contact your Cisco reseller.

**Table 3-1** OK LED Blinking Patterns

| Number of Blinks | Meaning                                                           |
|------------------|-------------------------------------------------------------------|
| 2                | The 860P dual-port random-access memory (DPRAM) has failed.       |
| 3                | The parameter RAM area of the 860P DPRAM has failed.              |
| 4                | The 860P system protection control register has a write failure.  |
| 5                | The router cannot detect the dynamic random-access memory (DRAM). |
| 6                | The user programmable machine has a write failure.                |
| 9                | The router DRAM has failed.                                       |

## Troubleshooting WICs and Cables

Use the **show diag** command to help determine problems with a card. [Table 3-2](#) lists problems that could occur with WAN interface cards (WICs) and the possible causes of these problems.

**Table 3-2** Troubleshooting WICs

| Symptom                                                                          | Possible Cause(s)                                                                                                                                                                                                                                                                                                                                                                           |
|----------------------------------------------------------------------------------|---------------------------------------------------------------------------------------------------------------------------------------------------------------------------------------------------------------------------------------------------------------------------------------------------------------------------------------------------------------------------------------------|
| Router does not recognize WIC.                                                   | <ul style="list-style-type: none"> <li>Confirm that the Cisco IOS software version installed in the router supports the WIC. The <a href="#">Cisco Interface Cards Hardware Installation Guide</a> lists the software requirements for each card.</li> <li>Use the <b>show diag</b> command to display information about the card as shown in <a href="#">Example, page 3-9</a>.</li> </ul> |
| Router recognizes the WIC(s), but the card port(s) do not initialize.            | <ul style="list-style-type: none"> <li>Make sure that the WIC is correctly installed in the router.</li> <li>Check the external cable connections to make sure they are secure.</li> </ul>                                                                                                                                                                                                  |
| Router does not boot properly, or router continuously or intermittently reboots. | Make sure that the WIC is correctly installed in the router.                                                                                                                                                                                                                                                                                                                                |

**Table 3-2 Troubleshooting WICs (continued)**

| Symptom                                                                           | Possible Cause(s)                                                                                                                                                                                                                                                                                                                                                                           |
|-----------------------------------------------------------------------------------|---------------------------------------------------------------------------------------------------------------------------------------------------------------------------------------------------------------------------------------------------------------------------------------------------------------------------------------------------------------------------------------------|
| Router boots, but the console screen is frozen.                                   | <ul style="list-style-type: none"> <li>• Make sure that the console cable is securely connected to the router and to the PC or terminal.</li> <li>• Verify that the parameters for your terminal are set to the following: <ul style="list-style-type: none"> <li>– 9600 baud</li> <li>– 8 data bits</li> <li>– No parity generated or checked</li> <li>– 1 stop bit</li> </ul> </li> </ul> |
| Router powers on and boots only when a particular WIC is removed from the router. | <ul style="list-style-type: none"> <li>• Confirm that the Cisco IOS software version installed in the router supports the WIC. The <a href="#">Cisco Interface Cards Hardware Installation Guide</a> lists the software requirements for each card.</li> <li>• The router might be overheating. Contact your Cisco reseller.</li> </ul>                                                     |
| Router powers on and boots only when a particular cable is disconnected.          | There might be a problem with the WIC or with the card cables. Consult your Cisco reseller for warranty information.                                                                                                                                                                                                                                                                        |

## Example

Below is an example of the **show diag** command:

```
815# show diag
Slot 0:
C815 1FE 4ESW CM Mainboard Port adapter, 6 ports
Port adapter is analyzed
Port adapter insertion time unknown
EEPROM contents at hardware discovery:
Hardware Revision       : 5.0
PCB Serial Number      : FOC09250KK8
Part Number             : 73-7546-05
Board Revision         : A0
Fab Version            : 04
Product (FRU) Number   : Unknown
Version Identifier      :
EEPROM format version 4
EEPROM contents (hex):
0x00: 04 FF 40 05 14 41 05 00 C1 8B 46 4F 43 30 39 32
0x10: 35 30 4B 4B 38 82 49 1D 7A 05 42 41 30 02 04 FF
0x20: FF FF FF FF FF FF FF FF FF FF FF FF FF FF FF
```

```

0x30: FF FF FF FF FF FF FF FF FF FF FF FF FF FF FF
0x40: FF FF FF FF FF FF FF FF FF FF FF FF FF FF FF
0x50: FF FF FF FF FF FF FF FF FF FF FF FF FF FF FF
0x60: FF FF FF FF FF FF FF FF FF FF FF FF FF FF FF
0x70: FF FF FF FF FF FF FF FF FF FF FF FF FF FF FF

```

WIC/VIC Slot 0:

4 Port FE Switch

Daughter card-Version 4 TLV Cookie Format

```

Hardware Revision      : 1.0
Part Number           : 73-8958-01
Board Revision        : D0
Deviation Number      : 0-0
Fab Version           : 01
PCB Serial Number     : FOC092153W5
RMA Test History      : 00
RMA Number            : 0-0-0-0
RMA History           : 00
Top Assy. Part Number : 800-24817-01
Connector Type        : 01
Base MAC Address      : 0014.6a56.a5dc
MAC Address block size : 20
Product (FRU) Number  : WIC-4ESW
CLEI Code             : IPMED00BRA

```

WIC/VIC Slot 1:

DOCSIS 2.0 Cable modem

Daughter card-Version 4 TLV Cookie Format

```

Hardware Revision      : 2.0
Board Revision        : 01
Deviation Number      : 0-0
Fab Version           : 02
PCB Serial Number     : FHH1003007G
RMA Test History      : 00
RMA Number            : 0-0-0-0
RMA History           : 00
Processor type        : 02
Top Assy. Part Number : 800-27077-02
Product (FRU) Number  : HWIC-CABLE-D-2
Version Identifier     : V01

```

Cable Modem Daughter Card

```

Base MAC Address      : 00d0.2bfe.66e6
MAC Address block size : 2
PCB Serial Number     : FOC06040116
Hardware Revision     : 2.0
Part Number           : 74-3862-02
Board Revision        : 01

```

```

EEPROM format version 4
EEPROM contents (hex):
0x00: 04 FF CF 06 00 D0 2B FE 66 E6 43 00 02 C1 8B 46
0x10: 4F 43 30 36 30 34 30 31 31 36 40 04 EA 41 02 00
0x20: 82 4A 0F 16 02 42 30 31 FF FF FF FF FF FF FF FF
0x30: FF FF FF FF FF FF FF FF FF FF FF FF FF FF FF
0x40: FF FF FF FF FF FF FF FF FF FF FF FF FF FF FF
0x50: FF FF FF FF FF FF FF FF FF FF FF FF FF FF FF
0x60: FF FF FF FF FF FF FF FF FF FF FF FF FF FF FF
0x70: FF FF FF FF FF FF FF FF FF FF FF FF FF FF FF
0x80: FF FF FF FF FF FF FF FF FF FF FF FF FF FF FF
0x90: FF FF FF FF FF FF FF FF FF FF FF FF FF FF FF
0xA0: FF FF FF FF FF FF FF FF FF FF FF FF FF FF FF
0xB0: FF FF FF FF FF FF FF FF FF FF FF FF FF FF FF
0xC0: FF FF FF FF FF FF FF FF FF FF FF FF FF FF FF
0xD0: FF FF FF FF FF FF FF FF FF FF FF FF FF FF FF
0xE0: FF FF FF FF FF FF FF FF FF FF FF FF FF FF FF
0xF0: FF FF FF FF FF FF FF FF FF FF FF FF FF FF FF

```

815#

## Troubleshooting the Power System

If the router external power supply fails, you should return it to your Cisco reseller. [Table 3-3](#) lists symptoms and possible causes of power problems.

**Table 3-3** Troubleshooting the Power System

| Symptom                                               | Possible Cause(s)                                                                                                                                                                                                                                                                                          |
|-------------------------------------------------------|------------------------------------------------------------------------------------------------------------------------------------------------------------------------------------------------------------------------------------------------------------------------------------------------------------|
| The router shuts down after being on a short time.    | <ul style="list-style-type: none"> <li>Make sure that the area in which the router is installed meets the environmental site requirements in <a href="#">Appendix A, “Technical Specifications,”</a> in this guide.</li> <li>If the front panel PWR LED is not on, the power supply has failed.</li> </ul> |
| The router attempts to boot, but all LEDs remain off. | The power supply has failed.                                                                                                                                                                                                                                                                               |

**Table 3-3**      *Troubleshooting the Power System (continued)*

| <b>Symptom</b>                                                                                                  | <b>Possible Cause(s)</b>     |
|-----------------------------------------------------------------------------------------------------------------|------------------------------|
| The router is on, but the front panel PWR LED is off.                                                           | The power supply has failed. |
| The front panel PWR LED is on, the front panel OK LED is off, and the router does not pass console or EIA data. | The power supply has failed. |



## Technical Specifications

[Table A-1](#) lists hardware and operating specifications for the Cisco 815 integrated services router.

**Table A-1** *Cisco 815 Integrated Services Router Specifications*

| Description              | Specification                                          |
|--------------------------|--------------------------------------------------------|
| Console port             | RJ-45                                                  |
| Auxiliary port           | RJ-45                                                  |
| Ethernet port            | RJ-45                                                  |
| Dimensions—<br>H x W x D | 3.1 x 11.2 x 8.7 in. (7.85 x 28.4 x 22.1 cm)           |
| Weight                   | 2.6 lb (1.18 kg)                                       |
| With two WICs            | 2.9 lb (1.32 kg)                                       |
| Power supply             | Locking connector on power socket                      |
| External                 | Universal AC/DC switching—Supplies +5V, +12V, and -12V |
| Onboard                  | Supplies 3.3V and -5V                                  |
| Power dissipation        | 20W                                                    |

**Table A-1** Cisco 815 Integrated Services Router Specifications (continued)

| Description                     | Specification                |
|---------------------------------|------------------------------|
| <b>Operating Specifications</b> |                              |
| Operating temperature           | 32° to 104°F (0° to 40°C)    |
| Storage temperature             | –40° to 149°F (–40° to 65°C) |
| Operating humidity              | 10% to 85%, noncondensing    |





## Cabling Specifications

---

This appendix describes cables and cabling guidelines for the Cisco 815 integrated services router and contains the following sections:

- [Ethernet Cables](#)
- [Ethernet Network Cabling Guidelines](#)
- [Console Cable and Adapter](#)



**Note**

---

For information about cables used with Cisco WAN interface cards (WICs), refer to the [Cisco Interface Cards Hardware Installation Guide](#).

---

## Ethernet Cables

This section describes the Ethernet cables that are used to connect the router to your local Ethernet network. A 10/100BASE-TX router, such as the Cisco 815 integrated services router, requires Category 5 unshielded twisted-pair (UTP) or shielded twisted-pair (STP) cable. [Table B-1](#) gives the pinouts for an Ethernet cable.

**Table B-1 Ethernet Cable Pinouts**

| RJ-45 Pin <sup>1</sup> | Signal | Direction | RJ-45 Pin |
|------------------------|--------|-----------|-----------|
| 1                      | TX+    | —>        | 1         |
| 2                      | TX-    | —>        | 2         |
| 3                      | RX+    | <—        | 3         |
| 6                      | RX-    | <—        | 6         |

1. Pins 4, 5, 7, and 8 are not used for signaling.

## Ethernet Network Cabling Guidelines

[Table B-2](#) describes some guidelines for creating Ethernet networks. Figures might vary, depending on the manufacturer of the network equipment.

**Table B-2 Ethernet Cabling Guidelines**

| Specification                          | 10BASE-T                | 100BASE-TX                                                                                                         |
|----------------------------------------|-------------------------|--------------------------------------------------------------------------------------------------------------------|
| Maximum segment length                 | 100 meters              | 100 meters                                                                                                         |
| Maximum number of segments per network | 5                       | <ul style="list-style-type: none"> <li>With Class I repeaters: 1</li> <li>With Class II repeaters: 2</li> </ul>    |
| Maximum hop count <sup>1</sup>         | 4                       | <ul style="list-style-type: none"> <li>With Class I repeaters: none</li> <li>With Class II repeaters: 1</li> </ul> |
| Maximum number of nodes per segment    | 1024                    | 1024                                                                                                               |
| Cable type required                    | UTP Category 3, 4, or 5 | UTP Category 5 or STP                                                                                              |

1. Hop count = Routing metric used to measure the distance between a source and a destination.

# Console Cable and Adapter

A console cable is provided with your router. Use this cable to connect the router to a PC or terminal. The router comes with a DB-9-to-DB-25 adapter that may be used for connecting the router to a modem, using the console cable.

[Table B-3](#) describes the wiring for the console port and the console cable. This table also includes pinouts for the DB-9-to-DB-25 adapter.

**Table B-3** Console Cable and Adapter Pinouts

| Console (DTE) | Console Port | Console Cable | Adapter   | Terminal (DTE) |
|---------------|--------------|---------------|-----------|----------------|
| Signal        | RJ-45 Pin    | DB-9 Pin      | DB-25 Pin | Signal         |
| RTS           | 1            | 8             | 5         | CTS            |
| DTR           | 2            | 6             | 8         | DSR            |
| TXD           | 3            | 2             | 3         | RXD            |
| GND           | 4            | 5             | 7         | GND            |
| GND           | 5            | 5             | 7         | GND            |
| RXD           | 6            | 3             | 2         | TXD            |
| DSR           | 7            | 4             | 20        | DTR            |
| CTS           | 8            | 7             | 4         | RTS            |





# Installing and Upgrading Memory and Virtual Private Network Modules

---

This chapter tells how to install or upgrade memory and how to install a Virtual Private Network (VPN) module in your Cisco 815 integrated services router and includes the following sections:

- [Safety Warnings](#)
- [Opening the Chassis](#)
- [Locating Modules](#)
- [Installing and Removing a DIMM](#)
- [Installing a VPN Module](#)
- [Closing the Chassis](#)

## Safety Warnings



**Warning**

---

**During this procedure, wear grounding wrist straps to avoid ESD damage to the router. Do not directly touch the backplane with your hand or any metal tool, or you could shock yourself.**

---



**Warning**

---

**Before working on a system that has an on/off switch, turn OFF the power and unplug the power cord.**

---

**Warning**

---

Do not work on the system or connect or disconnect cables during periods of lightning activity.

---

**Warning**

---

Read the installation instructions before you connect the system to its power source.

---

**Warning**

---

Before working on equipment that is connected to power lines, remove jewelry (including rings, necklaces, and watches). Metal objects will heat up when connected to power and ground and can cause serious burns or weld the metal object to the terminals.

---

**Warning**

---

Hazardous network voltages are present in WAN ports regardless of whether power to the router is OFF or ON. To avoid electric shock, use caution when working near WAN ports. When detaching cables, detach the end away from the router first.

---

## Opening the Chassis

In order to upgrade the Cisco 815 integrated services router memory, you must open the chassis. Opening the chassis requires a number one Phillips screwdriver.

Follow these steps to open the chassis:

- 
- Step 1** Make sure the router is turned off and is disconnected from the power supply.
  - Step 2** Turn the router upside down, and rest the top of the router on a flat surface.
  - Step 3** Use the number one Phillips screwdriver to remove the four screws that fasten the top and bottom of the chassis together, as shown in [Figure C-1](#).

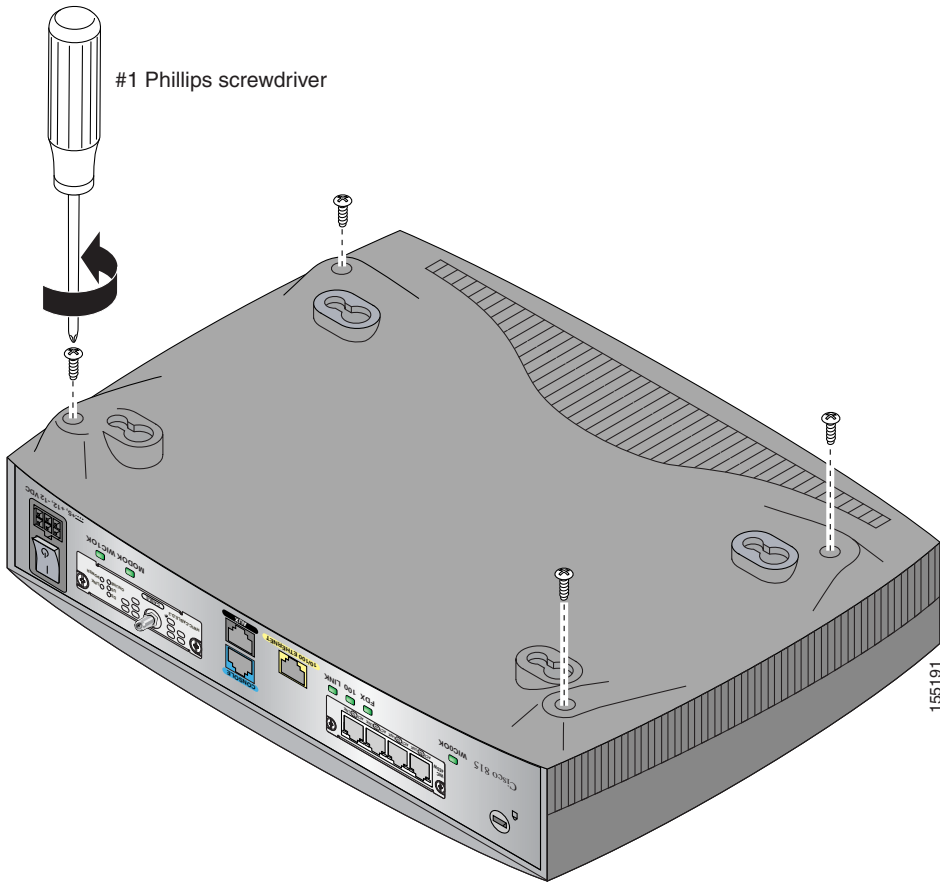
**Figure C-1** Removing the Chassis Screws

**Step 4** Holding the router assembly together, turn the router back to its original position.

**Step 5** Gently remove the top of the router (which is facing up toward you) up and away from the bottom of the router (which is resting on the flat surface).

At this point, you might have to disconnect the fan, which is inside the top of the router chassis, from the motherboard, by disconnecting the fan cable from the connector (labeled FAN) on the motherboard.

**Step 6** Place the router bottom on an antistatic mat, and begin installing memory.

# Locating Modules

Figure C-2 shows where to find the slots for a dual in-line memory module (DIMM) and a VPN module on the router motherboard.

**Figure C-2 Cisco 815 Integrated Services Router Motherboard—Memory Locations**

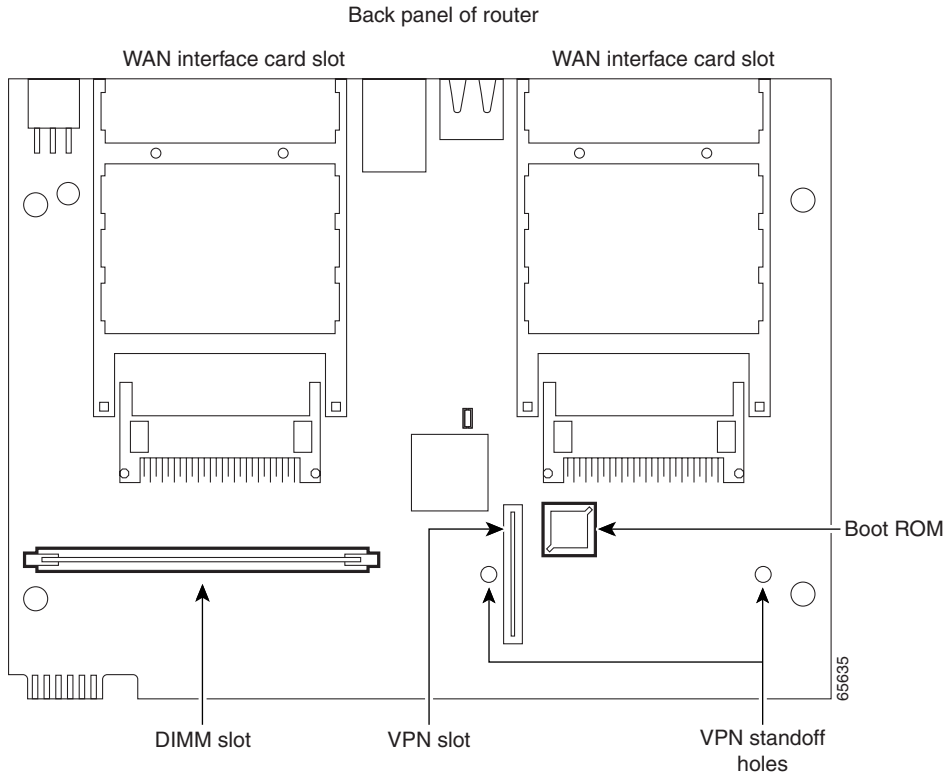

## Installing and Removing a DIMM

You can install a DIMM to increase the amount of dynamic random-access memory (DRAM) in the router.



DIMMs have a polarization notch on the mating edge to prevent incorrect insertion. [Figure C-3](#) shows the polarization notch on a DRAM DIMM.

**Figure C-3** DIMM Polarization Notch

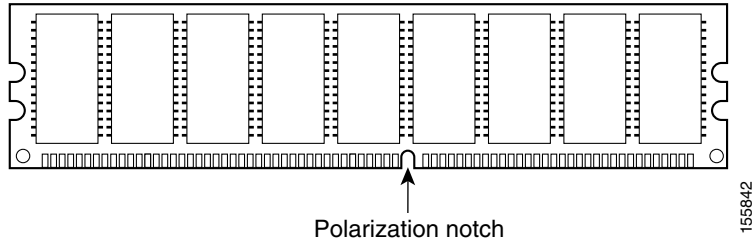

## Removing a DIMM

Follow these steps to remove a DIMM on the router motherboard:

- Step 1** Pull the latches away from the DIMM at both ends. This lifts the DIMM slightly. Lift the DIMM completely out of the connector. See [Figure C-4](#).

**Figure C-4** Removing a DIMM

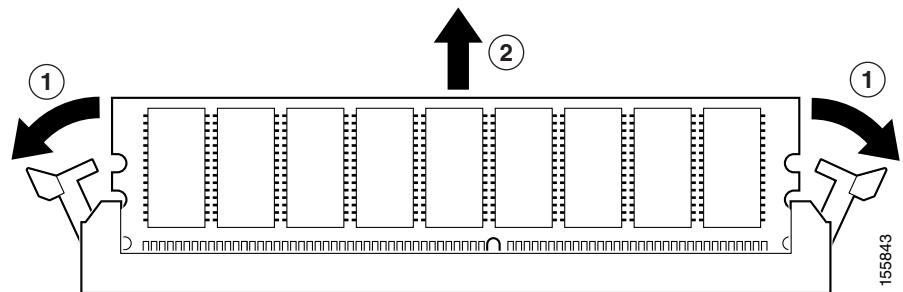

- |          |                     |          |                 |
|----------|---------------------|----------|-----------------|
| <b>1</b> | Release the latches | <b>2</b> | Remove the DIMM |
|----------|---------------------|----------|-----------------|

- Step 2** Place the DIMM in an antistatic bag to protect it from ESD damage.

## Installing a DIMM



### Caution

Do not insert DIMMs into the same connector more than 25 times. Overuse can damage the connector.

To install a DIMM, follow these steps:

- Step 1** Make sure that both latches on the DIMM connector are open.
- Step 2** Orient the DIMM so that the polarization notch lines up with the key in the connector. See [Figure C-5](#).
- Step 3** Carefully insert the DIMM into the connector.
- Step 4** Carefully and firmly press the DIMM into the connector until both latches rotate to the closed position against the DIMM.

**Figure C-5** Installing a DIMM

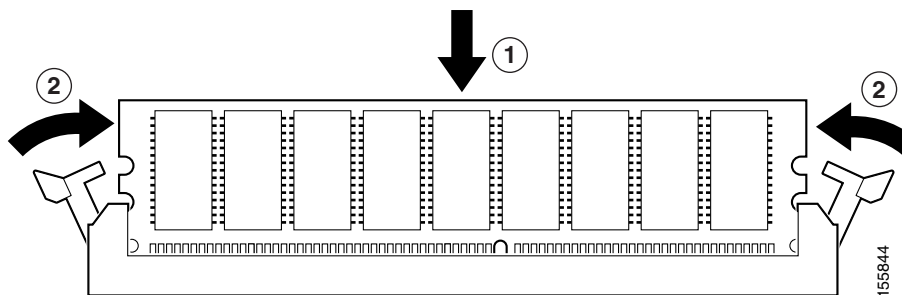

- |          |                 |          |                                   |
|----------|-----------------|----------|-----------------------------------|
| <b>1</b> | Insert the DIMM | <b>2</b> | Latches rotate to closed position |
|----------|-----------------|----------|-----------------------------------|

# Installing a VPN Module

**Caution**

To support the VPN module on the Cisco 815 integrated services router, the router must have Cisco advanced IP services IOS software and 128 MB of DRAM installed.

Follow these steps to install a VPN module:

- Step 1** Install the two standoffs on the module, as shown in [Figure C-6](#).

**Figure C-6** *Installing the Standoffs on the VPN Module*

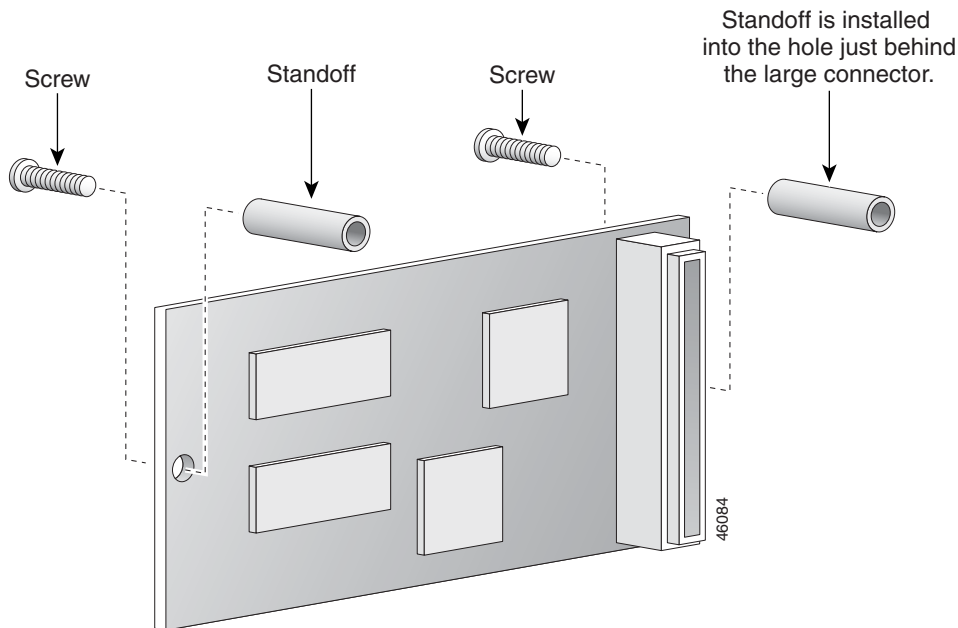

## ■ Installing a VPN Module

**Step 2** Locate the VPN module slot, and insert the VPN module, as shown in [Figure C-7](#).

**Figure C-7** VPN Module Location

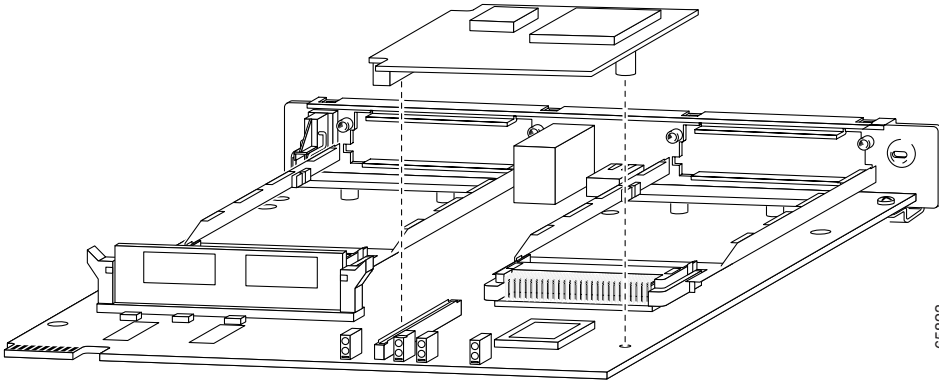

**Step 3** Pushing down as indicated in [Figure C-8](#), plug the VPN module into the slot.

**Figure C-8** Seating the VPN Module

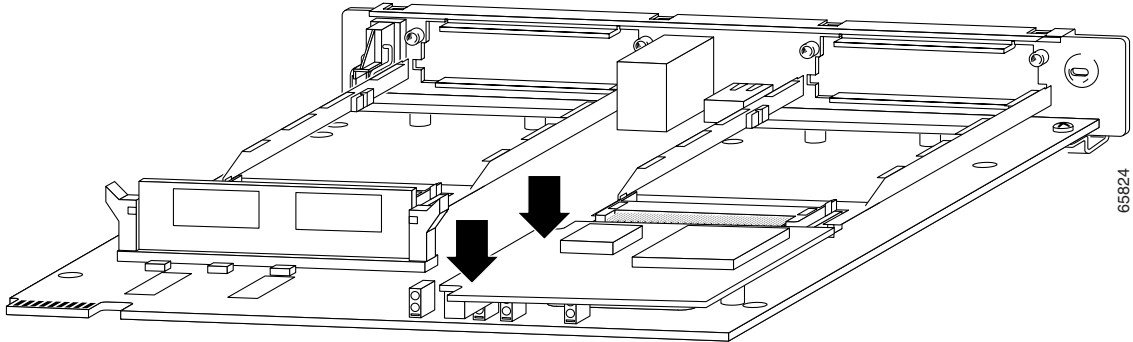

- Step 4** To secure the VPN board connection in the socket, you must attach a retention clip.
- The retention clip for the Cisco 815 integrated services router slides over the VPN module where it connects to the socket and clips to the side of the router motherboard. The horizontal tab slides underneath the WIC 0 socket, as shown in [Figure C-9](#).

**Figure C-9** Retention Clip Location

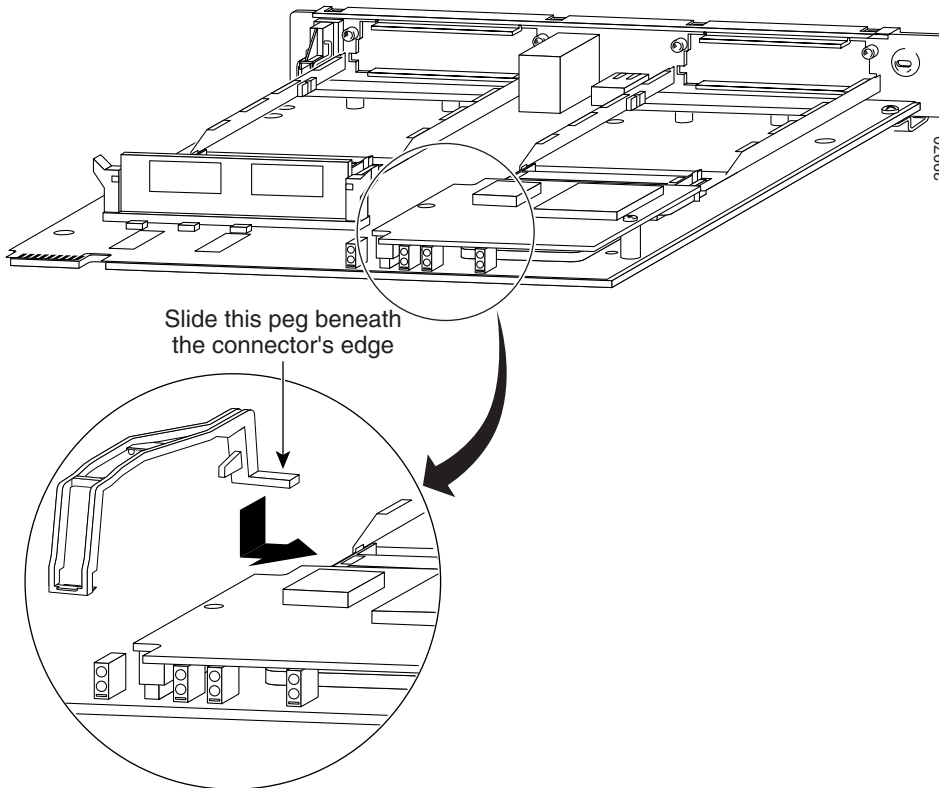

- Align the post in the middle of the clip with the hole in the center of the socket side of the VPN card as shown in [Figure C-10](#).

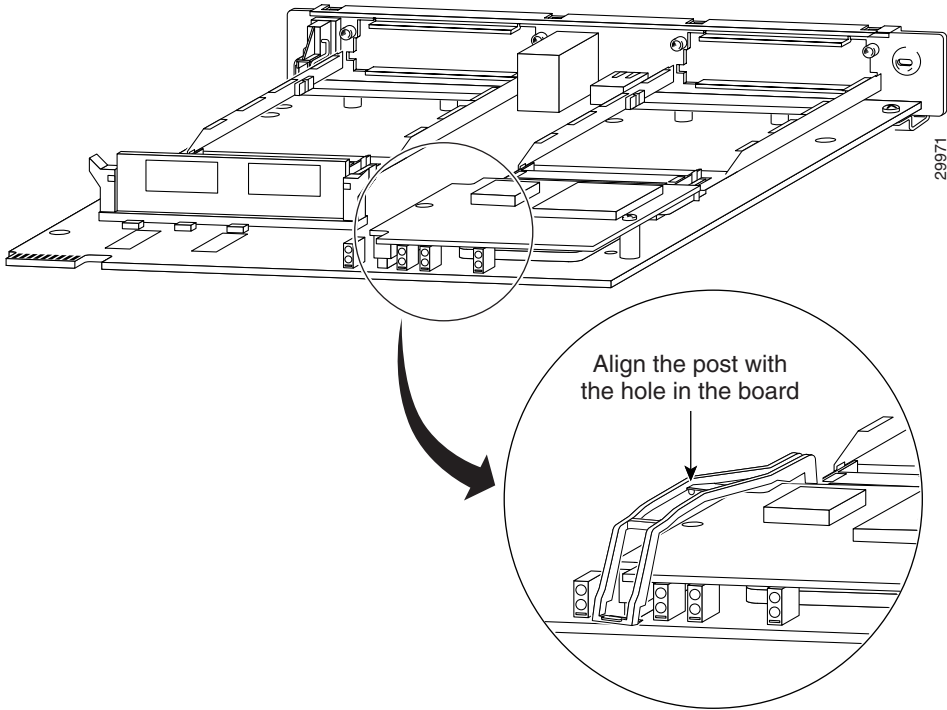
**Figure C-10** *Aligning the Retention Clip Center Post*

- c. Attach the retention clip to the motherboard, as shown in [Figure C-11](#).

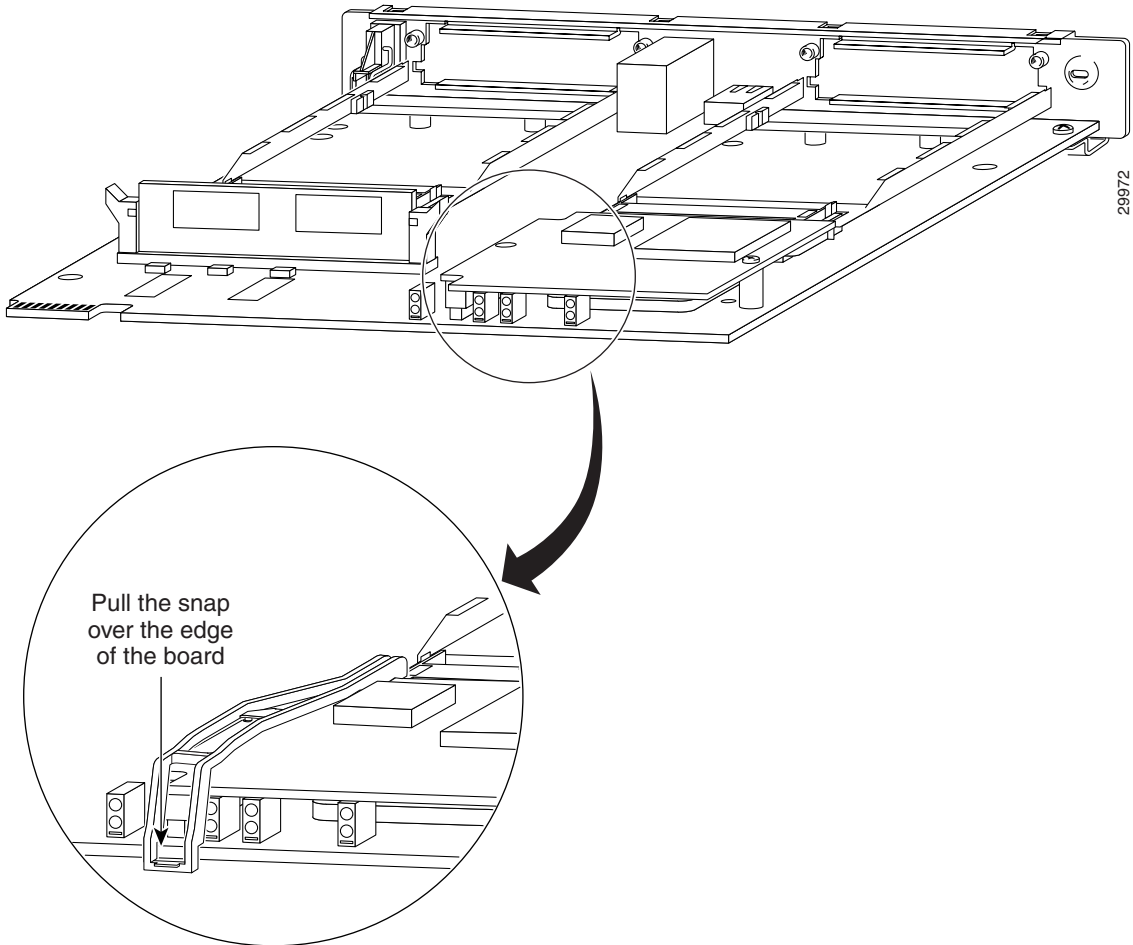
**Figure C-11** Attaching the Retention Clip to the Motherboard

- Step 5** Turn the motherboard over, so that it is resting on its top. Use a Phillips screwdriver to attach the standoffs to the motherboard by using the screws provided, as shown in [Figure C-12](#).

**Figure C-12** *Securing the Standoff to the Router Motherboard*

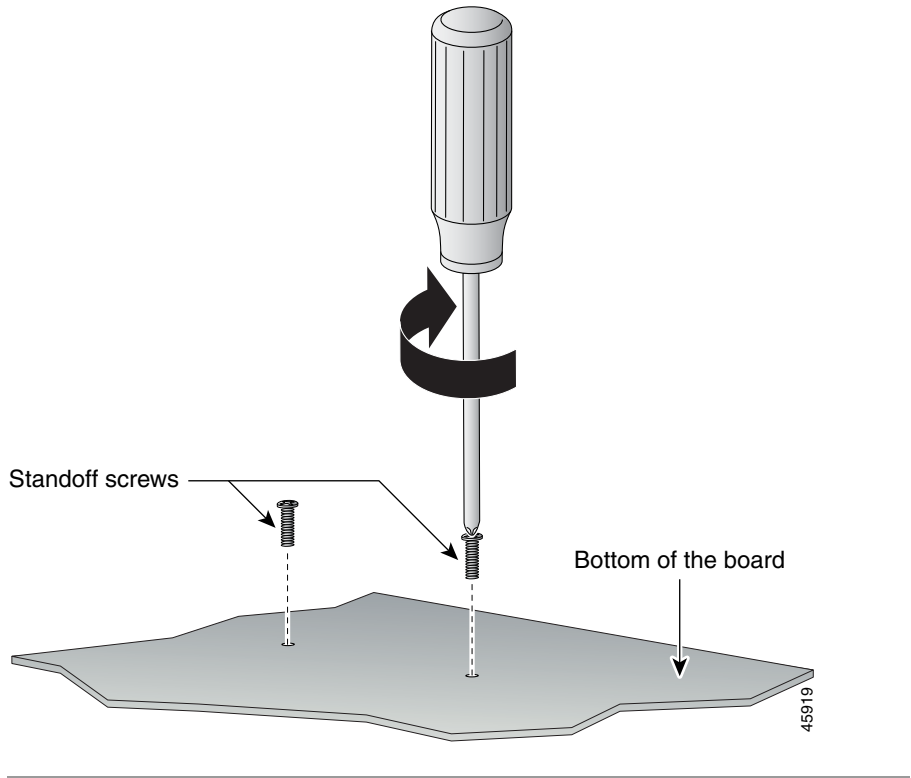



# Closing the Chassis

After installing memory or a VPN module on the motherboard, attach the router cover by following these steps:

- 
- Step 1** If you disconnected the fan from the motherboard in the [“Opening the Chassis”](#) procedure, reconnect the fan cable to the connector labeled FAN on the motherboard.
  - Step 2** Locate the posts that protrude from the inside of the chassis cover, and locate the corresponding openings on the chassis bottom.
  - Step 3** Line up the posts with the corresponding openings, as shown in [Figure C-8](#), and carefully slide the posts into the openings, taking care not to damage the router motherboard with the posts.

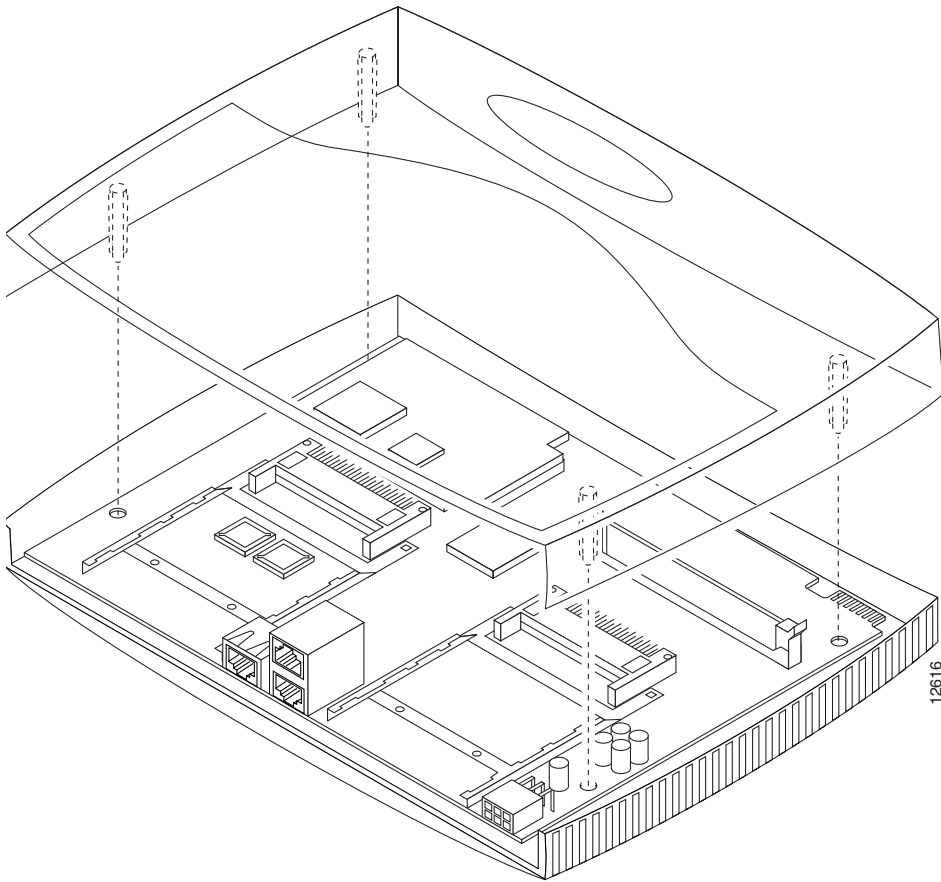
**Figure C-13** Attaching the Router Cover

- Step 4** Using a number one Phillips screwdriver, replace the screws that you removed when you opened the chassis. (See [Figure C-1.](#))



---

## Numerics

100 LED [1-6](#)

---

## A

auxiliary port

- connecting [2-9](#)
- description [1-2, 1-5](#)
- illustration [1-4](#)

---

## B

back panel

- connectors
  - description [1-5](#)
  - illustration [1-4](#)

LEDs

- description [1-6](#)
- illustration [1-4](#)

break, sending to router [3-4](#)

---

## C

cables

- console [B-3](#)
- Ethernet pinout [B-1](#)
- requirements for Ethernet networks [B-2](#)

caution, definition [xi](#)

chassis

- closing [C-13](#)
- dimensions [A-1](#)
- opening [C-2](#)

Cisco reseller, contacting [3-1](#)

closing chassis [C-13](#)

command conventions [xviii to xix](#)

commands

- config-register [3-6](#)
- configure terminal [3-6](#)
- copy [3-5, 3-6](#)
- enable [3-5](#)
- enable secret [3-6](#)
- reset [3-4](#)
- show startup-config [3-5](#)
- show version [1-9, 3-3](#)

config-register command [3-6](#)

configuration register

determining value [3-2 to 3-3](#)  
 resetting [3-6 to 3-7](#)  
 configure terminal command [3-6](#)  
 connecting  
   Ethernet cable [2-2](#)  
   power cord [2-5](#)  
   router to a PC [2-7](#)  
 console port  
   connecting [2-7](#)  
   description [1-2, 1-5](#)  
   illustration [1-4](#)  
   specifications [A-1](#)  
 conventions  
   command [xviii to xix](#)  
   text [xi](#)  
 copy command [3-5, 3-6](#)

---

## D

DIMM  
   installing [C-4](#)  
   locating on router [C-4](#)  
 documentation, related [x](#)  
 DRAM [1-8](#)

---

## E

enable command [3-5](#)  
 enable password, recovering [3-2](#)

enable secret command [3-6](#)  
 enable secret password, resetting [3-6](#)  
 ETH ACT LED [1-8](#)  
 ETH COL LED [1-8](#)  
 Ethernet cable  
   connecting [2-2](#)  
   pinouts [B-1](#)  
   requirements for networks [B-2](#)  
 Ethernet port  
   connecting [2-2, 2-3](#)  
   description [1-2, 1-5](#)  
   illustration [1-4](#)  
   specifications [A-1](#)

---

## F

FDX LED [1-6](#)  
 Flash memory [1-8](#)  
 front panel  
   illustration [1-2, 1-3](#)  
 LEDs  
   description [1-7 to 1-8](#)  
   illustration [1-7, 1-10](#)

---

## H

hub, connecting to [2-4](#)

**I**

## installing

DIMM [C-4](#)preparing for [2-1](#)stacking with other devices [2-10](#)verifying using LEDs [2-6](#)VPN [C-7 to C-12](#)**L**

## LEDs

back panel [1-4](#)front panel [1-7, 1-10](#)OK LED diagnostics [3-7](#)using to verify installation [2-6](#)LINK LED [1-6](#)**M**

## memory

description [1-8](#)

## DIMM

installing [C-4](#)locating on router [C-4](#)displaying amounts [1-9](#)DRAM [1-8](#)Flash [1-8](#)NVRAM [1-8](#)show version command [1-9](#)

## modem

connecting to router [2-9](#)support [1-2](#)MOD OK LED [1-6](#)**N**note, definition [xi](#)NVRAM [1-8](#)**O**

## OK LED

description [1-7](#)diagnostics [3-7](#)opening chassis [C-2](#)**P**password, recovering [3-2](#)

## PC

connecting to router [2-7](#)terminal emulation settings [2-7](#)

## pinouts

console cable [B-3](#)Ethernet cable [B-1](#)

## power socket

connecting [2-5](#)

illustration [1-4](#)  
specifications [A-1](#)  
problem solving [3-7](#)  
PWR LED [1-7](#)

---

## R

reset command [3-4](#)  
resetting the router [3-4 to 3-5](#)  
router  
    resetting [3-4 to 3-5](#)  
    specifications [A-2](#)  
    unpacking [1-10](#)

---

## S

show startup-config command [3-5](#)  
show version command [3-3](#)  
specifications, operating [A-2](#)  
stacking router with other devices [2-10](#)  
switch, connecting to [2-4](#)

---

## T

terminal emulation, settings [2-7](#)  
text conventions [xi](#)  
troubleshooting  
    cables [3-8](#)  
    contacting Cisco reseller [3-1](#)

password recovery [3-2](#)  
using the OK LED [3-7](#)  
WAN interface cards [3-8 to 3-9](#)

---

## U

unpacking the router [1-10](#)

---

## V

VPN module  
    installing [C-7 to C-12](#)  
    location on router [C-8](#)

---

## W

WAN interface cards  
    router slots [1-2](#)  
    slot specifications [A-1](#)  
    supported cards [1-2](#)  
    troubleshooting [3-8 to 3-9](#)  
warning, definition [xi](#)  
WIC0 ACT/CH0 LED [1-7](#)  
WIC0 ACT/CH1 LED [1-7](#)  
WIC0 OK LED [1-6](#)  
WIC1 OK LED [1-6](#)