



MPLS Layer 2 VPNs Configuration Guide, Cisco IOS XE 17 (Cisco ASR 920 Series)

First Published: 2019-11-14

Last Modified: 2021-04-07

Americas Headquarters

Cisco Systems, Inc.
170 West Tasman Drive
San Jose, CA 95134-1706
USA
<http://www.cisco.com>
Tel: 408 526-4000
800 553-NETS (6387)
Fax: 408 527-0883

THE SPECIFICATIONS AND INFORMATION REGARDING THE PRODUCTS IN THIS MANUAL ARE SUBJECT TO CHANGE WITHOUT NOTICE. ALL STATEMENTS, INFORMATION, AND RECOMMENDATIONS IN THIS MANUAL ARE BELIEVED TO BE ACCURATE BUT ARE PRESENTED WITHOUT WARRANTY OF ANY KIND, EXPRESS OR IMPLIED. USERS MUST TAKE FULL RESPONSIBILITY FOR THEIR APPLICATION OF ANY PRODUCTS.

THE SOFTWARE LICENSE AND LIMITED WARRANTY FOR THE ACCOMPANYING PRODUCT ARE SET FORTH IN THE INFORMATION PACKET THAT SHIPPED WITH THE PRODUCT AND ARE INCORPORATED HEREIN BY THIS REFERENCE. IF YOU ARE UNABLE TO LOCATE THE SOFTWARE LICENSE OR LIMITED WARRANTY, CONTACT YOUR CISCO REPRESENTATIVE FOR A COPY.

The Cisco implementation of TCP header compression is an adaptation of a program developed by the University of California, Berkeley (UCB) as part of UCB's public domain version of the UNIX operating system. All rights reserved. Copyright © 1981, Regents of the University of California.

NOTWITHSTANDING ANY OTHER WARRANTY HEREIN, ALL DOCUMENT FILES AND SOFTWARE OF THESE SUPPLIERS ARE PROVIDED "AS IS" WITH ALL FAULTS. CISCO AND THE ABOVE-NAMED SUPPLIERS DISCLAIM ALL WARRANTIES, EXPRESSED OR IMPLIED, INCLUDING, WITHOUT LIMITATION, THOSE OF MERCHANTABILITY, FITNESS FOR A PARTICULAR PURPOSE AND NON-INFRINGEMENT OR ARISING FROM A COURSE OF DEALING, USAGE, OR TRADE PRACTICE.

IN NO EVENT SHALL CISCO OR ITS SUPPLIERS BE LIABLE FOR ANY INDIRECT, SPECIAL, CONSEQUENTIAL, OR INCIDENTAL DAMAGES, INCLUDING, WITHOUT LIMITATION, LOST PROFITS OR LOSS OR DAMAGE TO DATA ARISING OUT OF THE USE OR INABILITY TO USE THIS MANUAL, EVEN IF CISCO OR ITS SUPPLIERS HAVE BEEN ADVISED OF THE POSSIBILITY OF SUCH DAMAGES.

Any Internet Protocol (IP) addresses and phone numbers used in this document are not intended to be actual addresses and phone numbers. Any examples, command display output, network topology diagrams, and other figures included in the document are shown for illustrative purposes only. Any use of actual IP addresses or phone numbers in illustrative content is unintentional and coincidental.

All printed copies and duplicate soft copies of this document are considered uncontrolled. See the current online version for the latest version.

Cisco has more than 200 offices worldwide. Addresses and phone numbers are listed on the Cisco website at www.cisco.com/go/offices.

Cisco and the Cisco logo are trademarks or registered trademarks of Cisco and/or its affiliates in the U.S. and other countries. To view a list of Cisco trademarks, go to this URL: <https://www.cisco.com/c/en/us/about/legal/trademarks.html>. Third-party trademarks mentioned are the property of their respective owners. The use of the word partner does not imply a partnership relationship between Cisco and any other company. (1721R)

© 2019–2021 Cisco Systems, Inc. All rights reserved.



CONTENTS

CHAPTER 1	Feature History	1
------------------	------------------------	----------

CHAPTER 2	L2VPN Protocol-Based CLIs	3
	Information About L2VPN Protocol-Based CLIs	3
	Overview of L2VPN Protocol-Based CLIs	3
	Benefits of L2VPN Protocol-Based CLIs	3
	L2VPN Protocol-Based CLI Changes	4
	MPLS L2VPN Protocol-Based CLI: Examples	8
	Additional References	11
	Feature Information for L2VPN Protocol-Based CLI	12

CHAPTER 3	Any Transport over MPLS	13
	Prerequisites for Any Transport over MPLS	14
	General Restrictions	14
	ATM AAL5 over MPLS Restrictions	15
	Ethernet over MPLS (EoMPLS) Restrictions	15
	Tunnel Selection Restrictions	15
	Remote Ethernet Port Shutdown Restrictions	16
	Restrictions for PPP and Multilink PPP	16
	Information About Any Transport over MPLS	16
	How AToM Transports Layer 2 Packets	17
	How AToM Transports Layer 2 Packets Using Commands Associated with L2VPN Protocol-Based Feature	18
	Benefits of AToM	19
	MPLS Traffic Engineering Fast Reroute	19
	Maximum Transmission Unit Guidelines for Estimating Packet Size	20

Estimating Packet Size Example	21
QoS Features Supported with AToM	21
Any Transport over MPLS (AToM) Remote Ethernet Port Shutdown	24
Any Transport over MPLS (AToM) Remote Ethernet Port Shutdown Using Commands Associated with L2VPN Protocol-Based Feature	26
AToM Load Balancing with Single PW	27
How to Configure Any Transport over MPLS	27
Configuring the Pseudowire Class	28
Configuring the Pseudowire Class Using Commands Associated with L2VPN Protocol-Based Feature	29
Changing the Encapsulation Type and Removing a Pseudowire	30
Changing the Encapsulation Type and Removing a Pseudowire Using Commands Associated with the L2VPN Protocol-Based Feature	30
Configuring ATM AAL5 over MPLS	30
Configuring ATM AAL5 over MPLS on PVCs	30
Configuring ATM AAL5 over MPLS on PVCs using the commands associated with the L2VPN Protocol-Based CLIs feature	32
Configuring ATM AAL5 over MPLS in VC Class Configuration Mode	34
Configuring ATM AAL5 over MPLS in VC Class Configuration Mode using the commands associated with the L2VPN Protocol-Based CLIs feature	36
Configuring Ethernet over MPLS	39
Configuring Ethernet over MPLS in VLAN Mode to Connect Two VLAN Networks That Are in Different Locations.	39
Configuring Ethernet over MPLS in VLAN Mode to Connect Two VLAN Networks That Are in Different Locations using the commands associated with the L2VPN Protocol-Based CLIs feature	40
Configuring Ethernet over MPLS in Port Mode	42
Configuring Ethernet over MPLS in Port Mode Using Commands Associated with the L2VPN Protocol-Based Feature	44
Configuring Ethernet over MPLS with VLAN ID Rewrite	46
Configuring Ethernet over MPLS with VLAN ID Rewrite Using Commands Associated with the L2VPN Protocol-Based Feature	49
Configuring Tunnel Selection	52
Troubleshooting Tips	54
Configuring Tunnel Selection Using Commands Associated with L2VPN Protocol-Based Feature	54

Troubleshooting Tips using the commands associated with the L2VPN Protocol-Based CLIs feature	57
Setting Experimental Bits with AToM	57
Enabling the Control Word	59
Enabling the Control Word using the commands associated with the L2VPN Protocol-Based CLIs feature	60
Configuring MPLS AToM Remote Ethernet Port Shutdown	61
Configuring MPLS AToM Remote Ethernet Port Shutdown using the commands associated with the L2VPN Protocol-Based CLIs feature	63
Configuration Examples for Any Transport over MPLS	64
Example: ATM over MPLS	64
Example: ATM over MPLS Using Commands Associated with L2VPN Protocol-Based Feature	65
Example: Configuring ATM AAL5 over MPLS in VC Class Configuration Mode	68
Example: Configuring ATM AAL5 over MPLS in VC Class Configuration Mode Using Commands Associated with L2VPN Protocol-Based Feature	68
Example: Ethernet over MPLS with MPLS Traffic Engineering Fast Reroute	69
Example: Ethernet over MPLS with MPLS Traffic Engineering Fast Reroute Using Commands Associated with L2VPN Protocol-Based Feature	71
Example: Configuring Tunnel Selection	75
Example: Configuring Tunnel Selection Using Commands Associated with L2VPN Protocol-Based Feature	77
Example: Configuring MTU Values in xconnect Configuration Mode for L2VPN Interworking	79
Example: Configuring MTU Values in xconnect Configuration Mode for L2VPN Interworking Using Commands Associated with L2VPN Protocol-Based Feature	82
Examples: Configuring Any Transport over MPLS (AToM) Remote Ethernet Port Shutdown	84
Examples: Configuring Any Transport over MPLS (AToM) Remote Ethernet Port Shutdown Using Commands Associated with L2VPN Protocol-Based Feature	85
Additional References for Any Transport over MPLS	86
Feature Information for Any Transport over MPLS	86
CHAPTER 4	
Loop-Free Alternate Fast Reroute	89
Prerequisites for Loop-Free Alternate Fast Reroute	89
Restrictions for Loop-Free Alternate Fast Reroute	89
Information About Loop-Free Alternate Fast Reroute	90
Supported Information	90

Benefits of Loop-Free Alternate Fast Reroute	90
LFA FRR and Remote LFA FRR over Bridge Domains Interfaces	91
IS-IS and IP FRR	91
Repair Paths	91
Remote LFA FRR	92
Remote LFA FRR for TDM and ATM Psuedowires	92
Border Gateway Protocol (BGP) Prefix-Independent Convergence (PIC) and LFA FRR Integration	92
Remote LFA FRR with VPLS	93
Remote LFA for MLDP	93
Restrictions for Remote LFA for MLDP	93
How to Configure Loop-Free Alternate Fast Reroute	94
Configuring IS-IS Remote Loop-Free Alternate Fast Reroute	94
Recommended Configurations ISIS	95
Example: Configuring IS-IS Remote Loop-Free Alternate Fast Reroute	95
Example: Configuring Remote LFA FRR with VPLS	96
How to Configure OSPF IPv4 Remote Loop-Free Alternate IP Fast Reroute	97
Configuring a Remote LFA Tunnel	97
Configuring the Maximum Distance to a Tunnel Endpoint	98
Configuring Remote LFA FRR for MLDP	98
Configuring IGP based Remote LFA for MLDP	99
Verifying Remote LFA for MLDP	100
Verifying Loop-Free Alternate Fast Reroute	105
Example: Verifying LFA FRR with L2VPN	105
Configuration Examples for OSPF IPv4 Remote Loop-Free Alternate IP Fast Reroute	108
Example: Configuring a Remote LFA Tunnel	108
Example: Configuring the Maximum Distance to a Tunnel Endpoint	108
Example: Verifying Tunnel Interfaces Created by OSPF IPv4 Remote LFA IPFRR	108
Verifying Remote Loop-Free Alternate Fast Reroute with VPLS	109
Example: Verifying Remote LFA FRR with VPLS	109
Verifying Tunnel Interfaces Created by OSPF IPv4 Remote LFA IPFRR	111
Additional References	112

Prerequisites for Virtual Private LAN Services	113
Restrictions for Virtual Private LAN Services	113
Information About Virtual Private LAN Services	114
VPLS Overview	114
Full-Mesh Configuration	115
Static VPLS Configuration	116
H-VPLS	116
Supported Features	116
Multipoint-to-Multipoint Support	116
Non-Transparent Operation	116
Circuit Multiplexing	116
MAC-Address Learning, Forwarding, and Aging	116
Jumbo Frame Support	116
Q-in-Q Support and Q-in-Q to EoMPLS VPLS Support	117
VPLS Services	117
How to Configure Virtual Private LAN Services	118
Configuring PE Layer 2 Interfaces on CE Devices	118
Configuring 802.1Q Access Ports for Tagged Traffic from a CE Device	118
Configuring 802.1Q Access Ports for Tagged Traffic from a CE Device: Alternate Configuration	119
Configuring Access Ports for Untagged Traffic from a CE Device	121
Configuring Access Ports for Untagged Traffic from a CE Device: Alternate Configuration	122
Configuring Q-in-Q EFP	124
Configuring Q-in-Q EFP: Alternate Configuration	125
Configuring MPLS on a PE Device	127
Configuring a VFI on a PE Device	128
Configuring a VFI on a PE Device: Alternate Configuration	129
Configuring Static Virtual Private LAN Services	130
Configuring a Pseudowire for Static VPLS	131
Configuring VFI for Static VPLS	133
Configuring a VFI for Static VPLS: Alternate Configuration	135
Configuring an Attachment Circuit for Static VPLS	137
Configuring an Attachment Circuit for Static VPLS: Alternate Configuration	138
Configuring an MPLS-TP Tunnel for Static VPLS with TP	140

Configuring a VFI for Static VPLS: Alternate Configuration	142
Configuration Examples for Virtual Private LAN Services	144
Example: Configuring 802.1Q Access Ports for Tagged Traffic from a CE Device	144
Example: Configuring 802.1Q Access Ports for Tagged Traffic from a CE Device: Alternate Configuration	145
Example: Configuring Access Ports for Untagged Traffic from a CE Device	145
Example: Configuring Access Ports for Untagged Traffic from a CE Device: Alternate Configuration	146
Example: Configuring Q-in-Q EFP	146
Example: Configuring Q-in-Q in EFP: Alternate Configuration	147
Example: Configuring MPLS on a PE Device	147
Example: VFI on a PE Device	148
Example: VFI on a PE Device: Alternate Configuration	148
Example: Full-Mesh VPLS Configuration	150
Example: Full-Mesh Configuration : Alternate Configuration	152
Feature Information for Configuring Virtual Private LAN Services	154
Layer 2 Protocol Tunneling	154

CHAPTER 6**VPLS MAC Address Withdrawal 159**

Information About VPLS MAC Address Withdrawal	159
VPLS MAC Address Withdrawal	159
VPLS MAC Address Withdrawal Using Commands Associated with L2VPN Protocol-Based Feature	160
How MAC Address Withdrawal Works with H-VPLS N-PE Redundancy with MPLS Access	161
How MAC Address Withdrawal Works with H-VPLS N-PE Redundancy with QinQ Access	161
Additional References for Any Transport over MPLS	161
Feature Information for VPLS MAC Address Withdrawal	162

CHAPTER 7**VPLS BGP Signaling 163**

Prerequisites for VPLS BGP Signaling	163
Information About VPLS BGP Signaling	163
Overview of VPLS BGP Signaling	163
How to Configure VPLS BGP Signaling	164
Configuring VPLS BGP Signaling	164

Configuration Examples for VPLS BGP Signaling	167
Example: Configuring and Verifying VPLS BGP Signaling	167
Additional References for VPLS BGP Signaling	168
Feature Information for VPLS BGP Signaling	169

CHAPTER 8**EVPN Virtual Private Wire Service (VPWS) Single Homed 171**

Information About EVPN-VPWS	171
Benefits of EVPN-VPWS Single Homed	172
Prerequisites for EVPN-VPWS	172
Restrictions for EVPN-VPWS	172
How to Configure EVPN-VPWS	173
Configuring BGP for EVPN-VPWS	173
Configuring EVPN-VPWS Instance	173
Rewrite for EVI Service Instance	173
Configuring EVPN-VPWS for Logging	174
Verifying EVPN-VPWS Instance	174
Verifying EVPN-VPWS Configuration	174
Verifying EVPN-VPWS Configuration for Logging	176
Troubleshooting	177
Virtual Circuit (VC) is in Down state	177
VC FSM History	178
Remote-Wait State	178
Configuration Examples for EVPN-VPWS Instance	179
Additional References for EVPN-VPWS	181

CHAPTER 9**N:1 PVC Mapping to PWE with Nonunique VPIs 183**

Restrictions for N:1 PVC Mapping to PWE with Nonunique VPIs	183
Information About N:1 PVC Mapping to PWE with Nonunique VPIs	184
N:1 PVC Mapping to PWE with Nonunique VPIs Feature Description	184
How to Configure N:1 PVC Mapping to PWE with Nonunique VPIs	184
Configuring N:1 PVC Mapping to PWE with Nonunique VPIs	184
Configuration Examples for N:1 PVC Mapping to PWE with Nonunique VPIs	186
Example: Configuring N:1 PVC Mapping to PWE with Nonunique VPIs	186
Verifying the N:1 PVC Mapping to PWE with Nonunique VPIs Configuration	187

Additional References 187

CHAPTER 10

Pseudowire Group Switchover 189

Finding Feature Information 189

Prerequisites for Pseudowire Group Switchover 189

Restrictions for Pseudowire Group Switchover 190

Information About Pseudowire Group Switchover 190

Introduction to Pseudowire Group Switchover 190

How to Configure Predictive Switchover 191

Configuring Predictive Switchover (Global Configuration Mode) 191

Configuring Predictive Switchover (Xconnect Configuration Mode) 191

Verifying a Pseudowire Group Switchover Configuration 192

Troubleshooting a Pseudowire Group Switchover Configuration 194

Configuration Examples for Predictive Switchover 194

Example: Configuring Predictive Switchover (Global Configuration Mode) 194

Example: Configuring Predictive Switchover (Xconnect Configuration Mode) 194

Additional References 194

Feature Information for Pseudowire Group Switchover 195

CHAPTER 11

Configuring Routed Pseudowire and VPLS 197

Prerequisites for Routed Pseudowire and VPLS 197

Restrictions for Routed Pseudowire and VPLS 197

Information About Routed Pseudowire and VPLS 198

Routed Pseudowire and VPLS 198

How to Configure Routed Pseudowire and VPLS 198

Assigning IP Addresses For Bridge Domain (BDI) 198

Configuring a VFI on a PE Device 199

Configuration Examples: Routed Pseudowire and VPLS 200

Example: Configuring Routed Pseudowire and VPLS 200

CHAPTER 12

VPLS over Backup Pseudowire 201

Prerequisites for VPLS over Backup Pseudowire 202

Restrictions for VPLS over Backup Pseudowire 202

Convergence Time for the VPLS Sessions 203

VPLS over Backup Pseudowire Configuration	203
Verify VPLS over Backup Pseudowire Configuration	205

CHAPTER 13**VPLS Configuration over MPLS-TP 209**

VPLS over MPLS-TP	209
Multiprotocol Label Switching Overview	209
Virtual Private LAN Services Overview	209
VPLS over MPLS-TP Overview	209
References	210
Configuring VPLS over MPLS-TP	210
Configuration Guidelines	210
Configuring the MPLS Label Range	210
Configuring the Router ID and Global ID	211
Configuring the Pseudowire Class	211
Configuring a BFD Template	212
Configuring the MPLS-TP Tunnel	213
Configuring MPLS-TP Links and Physical Interfaces	215
Configuring an Output Interface	215
Configuring an Access Interface	217
Configuring the VFI in the PE	218
Configuring a Virtual Loopback Interface	219
Verifying the Configuration	220
Configuration Examples	221
Feature Information for VPLS Configuration over MPLS-TP	222

CHAPTER 14**EVPN Single-Homing Over MPLS 223**

Feature History	224
Information about EVPN Single-Homing	224
Ethernet Multipoint Connectivity	224
EVPN Multipoint Solution	224
EVPN Building Blocks	225
Service Interfaces	225
Route Types	226
Prerequisites for EVPN Single-Homing	228

Restrictions for EVPN Single-Homing	228
How to Configure EVPN Single Homing	229
Configuring EVPN	229
Configuring EVPN Single-Homing	231
Verification Examples for EVPN Single-Homing	232
Additional References for EVPN Single-Homing	237

CHAPTER 15	Pseudowire Stitching	239
	Benefits of Pseudowire Stitching	239
	Configuring Pseudowire Stitching	239
	Verifying Pseudowire Stitching	240

CHAPTER 16	On-Change Notifications for L2VPN Pseudowire	241
	IOS State	241
	Telemetry and L2VPN Pseudowire	242
	Configuration Examples: On-Change Notifications for L2VPN Pseudowire	242
	Verification of On-Change Notifications for L2VPN Pseudowire Configuration	243



CHAPTER 1

Feature History

The following table lists the new and modified features supported in the MPLS Layer 2 VPNs Configuration Guide in Cisco IOS XE 17 releases.

Feature	Description
Cisco IOS XE Bengaluru 17.6.1	
Remote LFA for MLDP	Remote Loop-Free Alternate (RLFA) based Fast Reroute (FRR) improves LFA coverage. When used with Multicast Label Distribution Protocol (MLDP) for IPv4, there is no need for an extra protocol in the control plane.
Cisco IOS XE Bengaluru 17.5.1	
On-Change Notifications for L2VPN Pseudowire	This feature allows you to subscribe on-change Network Configuration Protocol (NETCONF) notifications for L2VPN pseudowire. You can generate an alert from a device when the pseudowire status changes.
Cisco IOS XE Amsterdam 17.3.1	
EVPN Single-Homing Over MPLS	The EVPN Single-Homing feature utilizes the BGP MPLS-based Ethernet VPN functionality as defined in RFC 7432. That is, to achieve single-homing between a Provider Edge (PE) and a Customer Edge (CE) device. There are three fundamental building blocks for EVPN technology, EVPN Instance (EVI), Ethernet Segment (ES), EVPN BGP routes and extended communities. For EVPN Single-Homing feature, a CE device is attached to a single PE device and has an Ethernet Segment.



CHAPTER 2

L2VPN Protocol-Based CLIs

The L2VPN Protocol-Based CLIs feature provides a set of processes and an improved infrastructure for developing and delivering Cisco IOS software on various Cisco platforms. This feature introduces new commands and modifies or replaces existing commands to achieve a consistent functionality across Cisco platforms and provide cross-Operating System (OS) support.

- [Information About L2VPN Protocol-Based CLIs, on page 3](#)
- [Additional References, on page 11](#)
- [Feature Information for L2VPN Protocol-Based CLI, on page 12](#)

Information About L2VPN Protocol-Based CLIs

Overview of L2VPN Protocol-Based CLIs

The L2VPN Protocol-Based CLIs feature introduces new commands and modifies or replaces existing commands to achieve a consistent functionality across Cisco platforms and provide cross-Operating System (OS) support.



Note The new, updated, and replacement commands are available in Cisco IOS XE Release 3.7S and Cisco IOS Release 15.3(1)S. However, the legacy commands that are being replaced will be deprecated in later releases.

Benefits of L2VPN Protocol-Based CLIs

The L2VPN Protocol-Based CLIs feature provides the following benefits:

- Consistent user experience across different operating systems.
- Consistent configuration for all Layer 2 VPN (L2VPN) scenarios.
- Enhanced functionality that is achieved by configuring pseudowires as virtual interfaces and monitoring the pseudowires as physical ports.
- Feature configuration such as quality of service (QoS) service policies on individual pseudowires .

- Redundant pseudowire configuration that is independent of the primary pseudowire to provide enhanced high availability.

These benefits are achieved through the following enhancements:

- New service contexts can be created for point-to-point and multipoint Layer 2 services by using the new L2VPN cross connect and L2VPN virtual forwarding interface (VFI) contexts.
 - The L2VPN cross connect context is used for configuring point-to-point pseudowires, pseudowire stitching, and local switching (hair pinning). Ethernet interfaces and subinterfaces, Ethernet Flow Points (EFP), ATM interfaces and WAN interfaces (PPP,HDLC,Serial), and pseudowire interfaces can be defined as members of an L2VPN cross connect context.
 - The L2VPN VFI context instantiates Virtual Private LAN Services (VPLS) VFI for multipoint scenarios. Pseudowires can be defined as members of an L2VPN VFI context.
 - Bridge domains or VLANs are used for multipoint scenarios. EFPs, pseudowires, or VFIs can be configured as members of a bridge domain. Pseudowires can be configured as member of a VFI. The VFI can be configured as a member of a VLANbridge domains.
- New port contexts can be created (dynamically or manually) for pseudowires by using the pseudowire interface.
- Pseudowire customization can be achieved using interface templates and pseudowire interfaces that are applied to L2VPN context members. Pseudowire customizations include following features:
 - Encapsulation type
 - Control word
 - Maximum Transmission Unit (MTU)
 - Pseudowire signaling type
 - Tunnel selection
- Interworking and redundancy group service attributes can be configured under the L2VPN service context. The redundancy groups are configured independently from the primary pseudowire, which helps achieve zero traffic interruptions while adding, modifying, or deleting backup pseudowires.

L2VPN Protocol-Based CLI Changes

The following commands are introduced in Cisco IOS XE Release 3.7S, Cisco IOS Release 15.3(1)S, and Cisco IOS Release 15.4(1)S:

- **debug l2vpn pseudowire**
- **l2vpn**
- **l2vpn pseudowire static-oam class**
- **monitor event-trace l2vpn**
- **show interface pseudowire**
- **show l2vpn service**

- **shutdown (MPLS)**
- **vc**

The following commands are modified in Cisco IOS XE Release 3.7S and Cisco IOS Release 15.3(1)S:

- **auto-route-target**
- **bridge-domain parameterized vlan**
- **debug condition xconnect fib**
- **debug condition xconnect interface**
- **debug condition xconnect peer**
- **debug condition xconnect segment**
- **description**
- **encapsulation (MPLS)**
- **forward permit l2protocol all**
- **interworking**
- **l2vpn subscriber authorization group**
- **l2vpn xconnect context**
- **load-balance flow**
- **monitor event-trace ac**
- **monitor event-trace atom**
- **monitor event-trace l2tp**
- **monitor peer bfd**
- **mtu**
- **preferred-path**
- **remote circuit id**
- **rd (VPLS)**
- **route-target (VPLS)**
- **sequencing**
- **status**
- **status admin-down disconnect**
- **status control-plane route-watch**
- **status decoupled**
- **status peer topology dual-homed**
- **status protocol notification static**

- status redundancy
- switching tlv
- tlv
- tlv template
- vccv
- vccv bfd status signaling
- vccv bfd template
- vpls-id
- vpn id (MPLS)

The table below lists the legacy commands that will be replaced in future releases. From Cisco IOS XE Release 3.7S and Cisco IOS Release 15.3(1)S both new and legacy commands will coexist until the legacy commands are deprecated in future releases.

Table 1: Replacement Commands Introduced in Cisco IOS XE Release 3.7S and Cisco IOS Release 15.3(1)S

Legacy Command	Replacement Command Introduced in Cisco IOS XE Release 3.7S and Cisco IOS Release 15.3(1)S
backup delay	redundancy delay (under l2vpn xconnect context)
bridge-domain (service instance)	member (bridge-domain)
clear mpls l2transport fsm state transition	clear l2vpn atom fsm state transition
clear mpls l2transport fsm event	clear l2vpn atom fsm event
clear xconnect	clear l2vpn service
connect (L2VPN local switching)	l2vpn xconnect context
debug acircuit	debug l2vpn acircuit
debug mpls l2transport checkpoint	debug l2vpn atom checkpoint
debug mpls l2transport event-trace	debug l2vpn atom event-trace
debug mpls l2transport fast-failure-detect	debug l2vpn atom fast-failure-detect
debug mpls l2transport signaling	debug l2vpn atom signaling
debug mpls l2transport static-oam	debug l2vpn atom static-oam
debug mpls l2transport vc subscriber	debug l2vpn atom vc
debug mpls l2transport vc	debug l2vpn atom vc
debug mpls l2transport vc vccv bfd event	debug l2vpn atom vc vccv
debug vfi	debug l2vpn vfi

Legacy Command	Replacement Command Introduced in Cisco IOS XE Release 3.7S and Cisco IOS Release 15.3(1)S
debug vfi checkpoint	debug l2vpn vfi checkpoint
debug xconnect	debug l2vpn xconnect
debug xconnect rib	debug l2vpn xconnect rib
description (L2VFI)	description (L2VPN)
l2 pseudowire routing	pseudowire routing
l2 router-id	router-id
l2 vfi	l2vpn vfi context
l2 subscriber	l2vpn subscriber
l2 vfi autodiscovery	autodiscovery
l2 vfi point-to-point	l2vpn xconnect context
local interface	pseudowire type
monitor event-trace st-pw-oam	monitor event-trace pwoam
mpls label	label (pseudowire)
mpls control-word	control-word (encapsulation mpls under l2vpn connect context)
neighbor (l2 vfi)	member (l2vpn vfi)
protocol	signaling protocol
pseudowire-static-oam class	l2vpn pseudowire static-oam class
pseudowire tlv template	l2vpn pseudowire tlv template
pw-class keyword in the xconnect command	source template type pseudowire
remote link failure notification	l2vpn remote link failure notification
show mpls l2transport binding	show l2vpn atom binding
show mpls l2transport checkpoint	show l2vpn atom checkpoint
show mpls l2transport hw-capability	show l2vpn atom hw-capability
show mpls l2transport static-oam	show l2vpn atom static-oam
show mpls l2transport summary	show l2vpn atom summary
show mpls l2transport pwid	show l2vpn atom pwid

Legacy Command	Replacement Command Introduced in Cisco IOS XE Release 3.7S and Cisco IOS Release 15.3(1)S
<code>show mpls l2transport vc</code>	<code>show l2vpn atom vc</code>
<code>show xconnect pwmib</code>	<code>show l2vpn pwmib</code>
<code>show xconnect rib</code>	<code>show l2vpn rib</code>
<code>show xconnect</code>	<code>show l2vpn service</code>
<code>show vfi</code>	<code>show l2vpn vfi</code>
<code>xconnect</code>	<code>l2vpn xconnect context</code> and <code>member</code>
<code>xconnect logging pseudowire status global</code>	<code>logging pseudowire status</code>
<code>xconnect logging redundancy global</code>	<code>logging redundancy</code>
<code>xconnect peer-ip vc-id</code>	<code>neighbor peer-ip vc-id (xconnect context)</code>

MPLS L2VPN Protocol-Based CLI: Examples

The examples in this section provide the new configurations that are introduced by the MPLS L2VPN Protocol-Based CLIs feature that replace the existing (legacy) MPLS L2VPN CLIs.

MPLS L2VPN VPWS Configuration Using Replacement (or New) Commands

The following example shows the configuration for Virtual Private Wired Service (VPWS)—Ethernet over Multiprotocol Label Switching (EoMPLS). In this example, L2VPN members point to peer ID or virtual circuit (VC) ID. This configuration is used in most cases except when features like quality of service (QoS), need to be applied at the pseudowire level.

```
l2vpn xconnect context foo
  member GigabitEthernet2/1/1 service-instance 300
  member 10.0.0.1 888 encapsulation mpls
!
interface GigabitEthernet2/1/1
  service instance 300 GigabitEthernetEthernet
  encapsulation dot1q 30
  rewrite ingress tag pop 1 symmetric
!
  service instance 400 GigabitEthernetEthernet
  encapsulation dot1q 40
  rewrite ingress tag pop 1 symmetric

l2vpn xconnect context faa
  member GigabitEthernet2/1/1 service-instance 400
  member 10.0.0.1 999 encapsulation mpls
!
```

MPLS L2VPN Pseudowire Configuration Using Replacement (or New) Commands

In the following example, L2VPN members point to a pseudowire interface. The pseudowire interface is manually configured and includes peer ID and VC ID. This configuration is used in most cases except when features like quality of service (QoS), need to be applied at the pseudowire level.

```
l2vpn xconnect context foo
  member GigabitEthernet2/1/1 service-instance 300
```

```

    member Pseudowire888
  !
interface Pseudowire 888
  encapsulation mpls
  neighbor 10.0.0.1 888
  !
interface Pseudowire 999
  encapsulation mpls
  neighbor 10.0.0.1 999
  !
interface GigabitEthernet2/1/1
  service instance 300 GigabitEthernetEthernet
  encapsulation dot1q 30
  rewrite ingress tag pop 1 symmetric
  !
  service instance 400 GigabitEthernetEthernet
  encapsulation dot1q 40
  rewrite ingress tag pop 1 symmetric

l2vpn xconnect context faa
  member GigabitEthernet2/1/1 service-instance 400
  member Pseudowire 999
  !

```

MPLS L2VPN Pseudowire Redundancy Configuration Using Replacement (or New) Commands

The following example shows the configuration for pseudowire redundancy. The new configuration shows concise pseudowire redundancy with no submodes or separate groups. This configuration allows the addition of redundant members to a service without service disruption. This configuration also allows modifying or deleting redundant service configurations without service disruption.

```

l2vpn xconnect context sample-pw-redundancy
  member Ethernet2/1GigabitEthernet2/1/1 service-instance 200
  member 10.1.1.1 180 encap mpls group Denver
  member 2.2.2.2 180180 encap mpls group Denver priority 1
  member 3.3.3.3 180181 encap mpls group Denver priority 2
  redundancy delay 1 20 group Denver
  !
interface GigabitEthernet2/1/1
  service instance 200 GigabitEthernetEthernet
  encapsulation dot1q 100
  rewrite ingress tag pop 1 symmetric

```

MPLS L2VPN Static Pseudowire Configuration Using Replacement (or New) Commands



Note The following configuration is shown for the Provider Edge (PE) 1 router in a network scheme where Customer Edge (CE) 1 and PE 1 and PE 2 and CE 2 traverse through a Provider core (P) router (CE 1—PE 1—P—PE 2—CE 2).

```

interface g2/1/1
  service instance 300 ethernet
  encapsulation dot1q 300
  no shutdown
  !
interface pseudowire 100
  neighbor 10.4.4.4 121
  encapsulation mpls
  label 200 300
  signaling protocol none
  no shutdown

```

```

!
l2vpn xconnect context foo
  member GigabitEthernet2/1/1 service-instance 300
  member pseudowire 100

```

MPLS L2VPN Static Pseudowire Template Configuration Using Replacement (or New) Commands



Note The following configuration is shown for the Provider Edge (PE) 1 router in a network scheme where Customer Edge (CE) 1 and PE 1 and PE 2 and CE 2 traverse through a Provider core (P) router (CE 1—PE 1—P—PE 2—CE 2).

```

template type pseudowire test
encapsulation mpls
signaling protocol none
!
interface g2/1/1
service instance 300 ethernet
encapsulation dot1q 300
no shutdown
!
interface pseudowire 100
neighbor 10.4.4.4 121
source template type pseudowire test
label 200 300
no shutdown
!
l2vpn xconnect context foo
  member GigabitEthernet2/1/1 service-instance 300
  member pseudowire 100

```

MPLS L2VPN Dynamic Pseudowire Template Configuration Using Replacement (or New) Commands



Note The following configuration is shown for the Provider Edge (PE) 1 router in a network scheme where Customer Edge (CE) 1 and PE 1 and PE 2 and CE 2 traverse through a Provider core (P) router (CE 1—PE 1—P—PE 2—CE 2).

```

template type pseudowire test
encapsulation mpls
signaling protocol ldp
!
!
interface g2/1/1
service instance 300 ethernet
encapsulation dot1q 300
no shutdown
!
interface pseudowire 100
neighbor 10.4.4.4 121
source template type pseudowire test
no shutdown
!
l2vpn xconnect context foo
  member GigabitEthernet2/1/1 service-instance 300
  member pseudowire 100

```

MPLS L2VPN Multi-segment Static-Dynamic Pseudowire Template Configuration Using Replacement (or New) Commands

The following PE router configuration is for a multi-segment static-dynamic pseudowire:

```
l2vpn pseudowire tlv template TLV
  tlv mtu 1 4 dec 1500
!
interface pseudowire401
  source template type pseudowire staticTempl
  encapsulation mpls
  neighbor 10.4.4.4 101
  signaling protocol none
  label 4401 4301
  pseudowire type 4
  tlv template TLV
  tlv 1 4 dec 1500
  tlv vccv-flags C 4 hexstr 0110
!
interface pseudowire501
  source template type pseudowire dynTempl
  encapsulation mpls
  neighbor 10.2.2.2 101
  signaling protocol ldp
```

Displaying MPLS L2VPN Pseudowire Template Configuration Using Replacement (or New) Commands

The following example displays output from the **show interface pseudowire** command:

```
PE1#show interface pseudowire 100
pseudowire100 is up
  Description: Pseudowire Interface
  MTU 1500 bytes, BW 10000000 Kbit
  Encapsulation mpls
  Peer IP 10.4.4.4, VC ID 121
  RX
    21 packets 2623 bytes 0 drops
  TX
    20 packets 2746 bytes 0 drops
```

The following example displays output from the **show template** command:

```
PE1#show template

Template      class/type      Component(s)
ABC           owner           interface pseudowire
BOUND: pw1
```

Sourcing a Template Under an Interface Pseudowire Using Replacement (or New) Commands

The following example configures the interface pseudowire to inherit all attributes defined from a template on the PE 2 router.

```
PE2(config-subif)#interface pseudowire 100
PE2(config-if)#source template type pseudowire test
PE2(config-if)#neighbor 10.4.4.4 121
PE2(config-if)#no shutdown
```

Additional References

Related Documents

Related Topic	Document Title
Cisco IOS commands	Cisco IOS Master Command List, All Releases

Related Topic	Document Title
MPLS commands	Multiprotocol Label Switching Command Reference

Technical Assistance

Description	Link
The Cisco Support and Documentation website provides online resources to download documentation, software, and tools. Use these resources to install and configure the software and to troubleshoot and resolve technical issues with Cisco products and technologies. Access to most tools on the Cisco Support and Documentation website requires a Cisco.com user ID and password.	http://www.cisco.com/cisco/web/support/index.html

Feature Information for L2VPN Protocol-Based CLI

The following table provides release information about the feature or features described in this module. This table lists only the software release that introduced support for a given feature in a given software release train. Unless noted otherwise, subsequent releases of that software release train also support that feature.

Use Cisco Feature Navigator to find information about platform support and Cisco software image support. To access Cisco Feature Navigator, go to www.cisco.com/go/cfn. An account on Cisco.com is not required.

Table 2: Feature Information for L2VPN Protocol-Based CLI

Feature Name	Releases	Feature Information
L2VPN Protocol-Based CLIs	Cisco IOS XE Release 3.13.0S	This feature was introduced on the Cisco ASR 920 Routers (ASR-920-12CZ-A, ASR-920-12CZ-D, ASR-920-4SZ-A, ASR-920-4SZ-D).



CHAPTER 3

Any Transport over MPLS

This module describes how to configure Any Transport over MPLS (AToM) transports data link layer (Layer 2) packets over a Multiprotocol Label Switching (MPLS) backbone. AToM enables service providers to connect customer sites with existing Layer 2 networks by using a single, integrated, packet-based network infrastructure--a Cisco MPLS network. Instead of using separate networks with network management environments, service providers can deliver Layer 2 connections over an MPLS backbone. AToM provides a common framework to encapsulate and transport supported Layer 2 traffic types over an MPLS network core.

AToM supports the following like-to-like transport types:

- ATM Adaptation Layer Type-5 (AAL5) over MPLS
- ATM Cell Relay over MPLS
- Ethernet over MPLS (VLAN and port modes)
- Circuit Emulation (CEM)
- Frame Relay over MPLS
- PPP over MPLS
- High-Level Data Link Control (HDLC) over MPLS



Note For information on ATM Cell relay and Circuit Emulation(CEM), see [Configuring Pseudowire](#).

- [Prerequisites for Any Transport over MPLS, on page 14](#)
- [General Restrictions, on page 14](#)
- [ATM AAL5 over MPLS Restrictions, on page 15](#)
- [Ethernet over MPLS \(EoMPLS\) Restrictions, on page 15](#)
- [Tunnel Selection Restrictions, on page 15](#)
- [Remote Ethernet Port Shutdown Restrictions, on page 16](#)
- [Restrictions for PPP and Multilink PPP, on page 16](#)
- [Information About Any Transport over MPLS, on page 16](#)
- [How to Configure Any Transport over MPLS, on page 27](#)
- [Configuration Examples for Any Transport over MPLS, on page 64](#)
- [Additional References for Any Transport over MPLS, on page 86](#)

- [Feature Information for Any Transport over MPLS, on page 86](#)

Prerequisites for Any Transport over MPLS

- IP routing must be configured in the core so that the provider edge (PE) routers can reach each other via IP.
- MPLS must be configured in the core so that a label-switched path (LSP) exists between the PE routers.
- Cisco Express Forwarding must be enabled before you configure any Layer 2 circuits.
- A loopback interface must be configured for originating and terminating Layer 2 traffic. Ensure that the PE routers can access the other router's loopback interface. Note that the loopback interface is not needed in all cases. For example, tunnel selection does not need a loopback interface when AToM is directly mapped to a traffic engineering (TE) tunnel.
- Before converting an interface with L2TPv3 xconnect to AToM xconnect, remove the L2TPv3 configuration from the interface and then configure AToM.
- Before configuring Ethernet over MLS in VLAN mode, you must configure Ethernet over MPLS on the subinterfaces.

General Restrictions

- In a member configuration, the **l2vpn xconnect context** command does not prompt any error or warning, if you specify without a service instance.
- The **show mpls l2transport vc <vcid> detail** command output displays few LDP-related information, even in case of static pseudowire.
- Address format--Configure the Label Distribution Protocol (LDP) router ID on all PE routers to be a loopback address with a /32 mask. Otherwise, some configurations might not function properly.
- For PTPoIP configuration with explicit Null MPLS encapsulation, when a Transparent Clock (TC) is placed between a PTP primary and a PTP subordinate, the TC does not update the correction field.
- Load balancing for Layer 2 VPN traffic on a Provider router is not supported on the RSP2 Module.
- Layer 2 virtual private networks (L2VPN) features (AToM and Layer 2 Tunnel Protocol Version 3 (L2TPv3)) are not supported on an ATM interface.
- Some features may not work if AToM is configured and L2TPv3 configuration is not removed properly.
- TE-FRR with BGP labels for layer 2 and layer 3 VPNs must terminate on the BGP gateway because of the four-label limitation.
- If an AToM tunnel spans different service providers that exchange MPLS labels using IPv4 Border Gateway Protocol (BGP) (RFC 3107), you add a label to the stack. The maximum MPLS label stack is five (FRR label, TE label, LDP label, VPN label, VC label)four (FRR label, TE label, LDP label, VC label).

- Hot standby pseudowire (HSPW) convergence without pseudowire grouping increments linearly. For example, for a thousand virtual circuits, it requires about 54 seconds of convergence time. This is applicable only for the Cisco RSP3 Module.

Clear interface is not the recommended way to measure the convergence numbers.

- With two ECMP paths, load sharing on L2VPN traffic occurs based on odd or even MPLS VC labels. If L2VPN circuits have either odd or even MPLS VC labels, load sharing is not performed. But if L2VPN circuits have a combination of both odd and even MPLS VC labels, then the odd MPLS VC labels circuits select one link whereas the even MPLS VC labels circuits select another link.
- Flow-Aware Transport (FAT) Load Balancing over VPLS is not supported.

ATM AAL5 over MPLS Restrictions

- AAL5 over MPLS is supported only in SDU mode.

Ethernet over MPLS (EoMPLS) Restrictions

- The subinterfaces between the CE and PE routers that are running Ethernet over MPLS must be in the same subnet.
- The subinterface on the adjoining CE router must be on the same VLAN as the PE router.
- Ethernet over MPLS supports VLAN packets that conform to the IEEE 802.1Q standard. The 802.1Q specification establishes a standard method for inserting VLAN membership information into Ethernet frames. The Inter-Switch Link (ISL) protocol is not supported between the PE and CE routers.
- The AToM control word is supported. However, if the peer PE does not support a control word, the control word is disabled.
- Ethernet packets with hardware-level cyclic redundancy check (CRC) errors, framing errors, and runt packets are discarded on input.

Tunnel Selection Restrictions

- The selected path should be an LSP destined to the peer PE router.
- The selected tunnel must be an MPLS TE tunnel.
- If you specify an IP address, that address must be the IP address of the loopback interface on the remote PE router. The address must have a /32 mask. There must be an LSP destined to that selected address. The LSP need not be a TE tunnel.

Remote Ethernet Port Shutdown Restrictions

This feature is not symmetrical if the remote PE router is running an older version image or is on another platform that does not support the EoMPLS remote Ethernet port shutdown feature and the local PE is running an image which supports this feature.

Remote Ethernet Port Shutdown is supported only on EFP with encapsulation default.

Restrictions for PPP and Multilink PPP

- All member links in a Multilink PPP bundle must be on the same interface module.
- All member links in a Multilink PPP bundle must be of the same bandwidth.
- A maximum of 16 member links per bundle is supported.
- Perform a shutdown or no shutdown of the Multilink PPP bundle to change the bundle fragmentation mode between enabled and disabled.
- Link Fragmentation and Interleaving (LFI) is not supported. However, Multilink PPP fragmentation is supported by default. To disable fragmentation, see *Disabling PPP Multilink Fragmentation* section.
- Multicast Multilink PPP is not supported.
- PPP compression is not supported.
- IPv6 is not supported for this feature.
- PPP half bridging is not supported.
- To enable an Address-and-Control-Field-Compression (ACFC) or Protocol-Field-Compression (PFC) configuration, perform a shutdown or no shutdown on the serial interface.
- Fractional timeslots cannot be used as memberlink in a Multilink PPP bundle.
- Frame Relay (FR) and Multilink Frame Relay (MFR) are not supported.
- Compressing IP or UDP or RTP headers are not supported.
- PPP and Multilink PPP are supported on synchronous serial interfaces. Asynchronous serial interfaces, High-Speed Serial Interfaces (HSSI), and ISDN interfaces are not supported.
- When you configure interfaces on each end of an Multilink PPP connection with different MTU values, the link drops traffic at high traffic rates. The configuration of the same MTU is recommended.

Information About Any Transport over MPLS

To configure AToM, you must understand the following concepts:

How AToM Transports Layer 2 Packets

AToM encapsulates Layer 2 frames at the ingress PE and sends them to a corresponding PE at the other end of a pseudowire, which is a connection between the two PE routers. The egress PE removes the encapsulation and sends out the Layer 2 frame.

The successful transmission of the Layer 2 frames between PE routers is due to the configuration of the PE routers. You set up the connection, called a pseudowire, between the routers. You specify the following information on each PE router:

- The type of Layer 2 data that will be transported across the pseudowire, such as Ethernet, Frame Relay, or ATM
- The IP address of the loopback interface of the peer PE router, which enables the PE routers to communicate
- A unique combination of peer PE IP address and VC ID that identifies the pseudowire

The following example shows the basic configuration steps on a PE router that enable the transport of Layer 2 packets. Each transport type has slightly different steps.

Step 1 defines the interface or subinterface on the PE router:

```
Router# interface  
interface-type interface-number
```

Step 2 configures an ethernet service instance on an interface and enters service instance configuration mode:

```
Router(config-if)#service instance number ethernet WORD  
Router(config-if)# service instance 393 ethernet ethernet1
```

Step 2 3 specifies the encapsulation type for the interface, such as dot1q:

```
Router(config-if-srv)# encapsulation  
encapsulation-type
```

Step 4 does the following:

- Makes a connection to the peer PE router by specifying the LDP router ID of the peer PE router.
- Specifies a 32-bit unique identifier, called the VC ID, which is shared between the two PE routers.

The combination of the peer router ID and the VC ID must be unique on the router. Two circuits cannot use the same combination of peer router ID and VC ID.

- Specifies the tunneling method used to encapsulate data in the pseudowire. AToM uses MPLS as the tunneling method.

```
Router(config-if-srv)# xconnect  
peer-router-id vcid  
encapsulation mpls
```

As an alternative, you can set up a pseudowire class to specify the tunneling method and other characteristics. For more information, see the [Configuring the Pseudowire Class, on page 28](#).

How AToM Transports Layer 2 Packets Using Commands Associated with L2VPN Protocol-Based Feature

AToM encapsulates Layer 2 frames at the ingress PE and sends them to a corresponding PE at the other end of a pseudowire, which is a connection between the two PE routers. The egress PE removes the encapsulation and sends out the Layer 2 frame.

The successful transmission of the Layer 2 frames between PE routers is due to the configuration of the PE routers. You set up the connection, called a pseudowire, between the routers. You specify the following information on each PE router:

- The type of Layer 2 data that will be transported across the pseudowire, such as Ethernet, Frame Relay, or ATM
- The IP address of the loopback interface of the peer PE router, which enables the PE routers to communicate
- A unique combination of peer PE IP address and VC ID that identifies the pseudowire

The following example shows the basic configuration steps on a PE router that enable the transport of Layer 2 packets. Each transport type has slightly different steps.

Step 1 defines the interface or subinterface on the PE router:

```
Router# interface
interface-type interface-number

Router(config)# interface gi 0/1/0
```

Step 2 configures an ethernet service instance on an interface and enters service instance configuration mode:

```
Router(config-if)#service instance number ethernet WORD
Router(config-if)# service instance 393 ethernet ethernet1
```

Step 3 specifies the encapsulation type for the interface, such as dot1q:

```
Router(config-if)# encapsulation
encapsulation-type

Router(config-if-srv)# encapsulation dot1q 393
```

Step 3 does the following:

- Makes a connection to the peer PE router by specifying the LDP router ID of the peer PE router.
- Specifies a 32-bit unique identifier, called the VC ID, which is shared between the two PE routers.

The combination of the peer router ID and the VC ID must be unique on the router. Two circuits cannot use the same combination of peer router ID and VC ID.

- Specifies the tunneling method used to encapsulate data in the pseudowire. AToM uses MPLS as the tunneling method.

```
Router(config)# interface pseudowire 100
Router(config-if)# encapsulation mpls
Router(config-if)# neighbor 10.0.0.1 123
Router(config-if)# exit
!
```

```

Router(config)# l2vpn xconnect context A
Router(config-xconnect)# member pseudowire 100
Router(config-xconnect)# member gigabitethernet0/0/0.1
Router (config-xconnect)# member gigabitethernet0/1/0 service instance 393

Router(config-xconnect)# exit

```

As an alternative, you can set up a pseudowire class to specify the tunneling method and other characteristics. For more information, see the [Configuring the Pseudowire Class, on page 28](#).

Benefits of AToM

The following list explains some of the benefits of enabling Layer 2 packets to be sent in the MPLS network:

- The AToM product set accommodates many types of Layer 2 packets, including Ethernet and Frame Relay, across multiple Cisco router platforms. This enables the service provider to transport all types of traffic over the backbone and accommodate all types of customers.
- AToM adheres to the standards developed for transporting Layer 2 packets over MPLS. This benefits the service provider that wants to incorporate industry-standard methodologies in the network. Other Layer 2 solutions are proprietary, which can limit the service provider's ability to expand the network and can force the service provider to use only one vendor's equipment.
- Upgrading to AToM is transparent to the customer. Because the service provider network is separate from the customer network, the service provider can upgrade to AToM without disruption of service to the customer. The customers assume that they are using a traditional Layer 2 backbone.

MPLS Traffic Engineering Fast Reroute

AToM can use MPLS traffic engineering (TE) tunnels with fast reroute (FRR) support. AToM VCs can be rerouted around a failed link or node at the same time as MPLS and IP prefixes.

Enabling fast reroute on AToM does not require any special commands; you can use standard fast reroute commands. At the ingress PE, an AToM tunnel is protected by fast reroute when it is routed to an FRR-protected TE tunnel. Both link and node protection are supported for AToM VCs at the ingress PE.

In the following example, the primary link is disabled, which causes the backup tunnel (Tunnel 1) to become the primary path. The output in boldface font shows the status of the tunnel:

```

Router# execute-on slot 3 debug mpls l2transport fast-reroute
===== Line Card (Slot 3) =====
AToM fast reroute debugging is on
SLOT 3:Sep 16 17:58:56.346: AToM SMGR: Processing TFIB FRR event for 10.4.0.1
SLOT 3:Sep 16 17:58:56.346: AToM SMGR: Finished processing TFIB FRR event for 10.4.0.1
SLOT 3:Sep 16 17:58:56.346: AToM SMGR: Processing TFIB FRR event for Tunnel141
SLOT 3:Sep 16 17:58:56.346: AToM SMGR: Finished processing TFIB FRR event for Tunnel141
Sep 16 17:58:58.342: %LINK-3-UPDOWN: Interface POS0/0/0, changed state to down
Sep 16 17:58:58.342: %OSPF-5-ADJCHG: Process 1, Nbr 10.0.0.1 on POS0/0 from FULL to DOWN, Neighbor Down: Interface down or detached
Sep 16 17:58:59.342: %LINEPROTO-5-UPDOWN: Line protocol on Interface POS0/0/0, changed state to down

```

Maximum Transmission Unit Guidelines for Estimating Packet Size

The following calculation helps you determine the size of the packets traveling through the core network. You set the maximum transmission unit (MTU) on the core-facing interfaces of the P and PE routers to accommodate packets of this size. The MTU should be greater than or equal to the total bytes of the items in the following equation:

$$\text{Core MTU} \geq (\text{Edge MTU} + \text{Transport header} + \text{AToM header} + (\text{MPLS label stack} * \text{MPLS label size}))$$

The following sections describe the variables used in the equation.

Edge MTU

The edge MTU is the MTU for the customer-facing interfaces.

Transport Header

The Transport header depends on the transport type. The table below lists the specific sizes of the headers.

Table 3: Header Size of Packets

Transport Type	Packet Size
AAL5	0-32 bytes
Ethernet VLAN	18 bytes
Ethernet Port	14 bytes
Frame Relay DLCI	2 bytes for Cisco encapsulation, 8 bytes for Internet Engineering Task Force (IETF) encapsulation
HDLC	4 bytes
PPP	4 bytes

AToM Header

The AToM header is 4 bytes (control word). The control word is optional for Ethernet, PPP, HDLC, and cell relay transport types. The control word is required for Frame Relay and ATM AAL5 transport types.

MPLS Label Stack

The MPLS label stack size depends on the configuration of the core MPLS network:

- AToM uses one MPLS label to identify the AToM VCs (VC label). Therefore, the minimum MPLS label stack is one for directly connected AToM PEs, which are PE routers that do not have a P router between them.
- If LDP is used in the MPLS network, the label stack size is two (the LDP label and the VC label).
- If a TE tunnel instead of LDP is used between PE routers in the MPLS network, the label stack size is two (the TE label and the VC label).

- If a TE tunnel and LDP are used in the MPLS network (for example, a TE tunnel between P routers or between P and PE routers, with LDP on the tunnel), the label stack is three (TE label, LDP label, VC label).
- If you use MPLS fast reroute in the MPLS network, you add a label to the stack. The maximum MPLS label stack in this case is four (FRR label, TE label, LDP label, VC label).
- If AToM is used by the customer carrier in an MPLS VPN Carrier Supporting Carrier environment, you add a label to the stack. The maximum MPLS label stack in the provider carrier network is five (FRR label, TE label, LDP label, VPN label, VC label)four (FRR label, TE label, LDP label, VC label).
- BGP PIC Edge with EoMPLS using BGP label Unicast (RFC 3107) requires the **bgp mpls-local-label** command to be explicitly enabled under the Router BGP process. This limitation is applicable only on the Cisco RSP3 module.
- If an AToM tunnel spans different service providers that exchange MPLS labels using IPv4 Border Gateway Protocol (BGP) (RFC 3107), you add a label to the stack. The maximum MPLS label stack is five (FRR label, TE label, LDP label, VPN label, VC label)four (FRR label, TE label, LDP label, VC label)
- TE-FRR with BGP labels for layer 2 and layer 3 VPNs must terminate on the BGP gateway because of the four-label limitation.

Other circumstances can increase the MPLS label stack size. Therefore, analyze the complete data path between the AToM tunnel endpoints and determine the maximum MPLS label stack size for your network. Then multiply the label stack size by the size of the MPLS label.

Estimating Packet Size Example

The estimated packet size in the following example is 1526 bytes, based on the following assumptions:

- The edge MTU is 1500 bytes.
- The transport type is Ethernet VLAN, which designates 18 bytes for the transport header.
- The AToM header is 0, because the control word is not used.
- The MPLS label stack is 2, because LDP is used. The MPLS label is 4 bytes.

$$\begin{array}{rcccccccc} \text{Edge MTU} & + & \text{Transport header} & + & \text{AToM header} & + & (\text{MPLS label stack} & * & \text{MPLS label}) & = & \text{Core MTU} \\ 1500 & + & 18 & + & 0 & + & (2 & * & 4 &) & = & 1526 \end{array}$$

You must configure the P and PE routers in the core to accept packets of 1526 bytes.

QoS Features Supported with AToM

The tables below list the QoS features supported by AToM.

Table 4: QoS Features Supported with Ethernet over MPLS

QoS Feature	Ethernet over MPLS
Service policy	Can be applied to: <ul style="list-style-type: none"> • Interface (input and output)

QoS Feature	Ethernet over MPLS
Classification	Supports the following commands: <ul style="list-style-type: none"> • match cos (on interfaces) • match mpls experimental (on interfaces) • match qos-group (on interfaces) (output policy)
Marking	Supports the following commands: <ul style="list-style-type: none"> • set cos (output policy) • set discard-class (input policy) • set mpls experimental (input policy) (on interfaces) • set qos-group (input policy)
Policing	Supports the following: <ul style="list-style-type: none"> • Color-aware policing • Multiple-action policing • Single-rate policing • Two-rate policing
Queueing and shaping	Supports the following: <ul style="list-style-type: none"> • Byte-based WRED • Low Latency Queueing (LLQ) • Weighted Random Early Detection (WRED)

Table 5: QoS Features Supported with Frame Relay over MPLS

QoS Feature	Frame Relay over MPLS
Service policy	Can be applied to: <ul style="list-style-type: none"> • Interface (input and output) • PVC (input and output)
Classification	Supports the following commands: <ul style="list-style-type: none"> • match fr-de (on interfaces and VCs) • match fr-dlci (on interfaces) • match qos-group

QoS Feature	Frame Relay over MPLS
Marking	Supports the following commands: <ul style="list-style-type: none"> • frame-relay congestion management (output) • set discard-class • set fr-de (output policy) • set fr-fecn-becn (output) • set mpls experimental • set qos-group • threshold ecn (output)
Policing	Supports the following: <ul style="list-style-type: none"> • Color-aware policing • Multiple-action policing • Single-rate policing • Two-rate policing
Queueing and shaping	Supports the following: <ul style="list-style-type: none"> • Byte-based WRED • Class-based weighted fair queueing (CBWFQ) • LLQ • random-detect discard-class-based command • Traffic shaping • WRED

Table 6: QoS Features Supported with ATM Cell Relay and AAL5 over MPLS

QoS Feature	ATM Cell Relay and AAL5 over MPLS
Service policy	Can be applied to: <ul style="list-style-type: none"> • Interface (input and output) • PVC (input and output) • Subinterface (input and output)

QoS Feature	ATM Cell Relay and AAL5 over MPLS
Classification	Supports the following commands: <ul style="list-style-type: none"> • match mpls experimental (on VCs) • match qos-group (output)
Marking	Supports the following commands: <ul style="list-style-type: none"> • random-detect discard-class-based (input) • set clp (output) (on interfaces, subinterfaces, and VCs) • set discard-class (input) • set mpls experimental (input) (on interfaces, subinterfaces, and VCs) • set qos-group (input)
Policing	Supports the following: <ul style="list-style-type: none"> • Color-aware policing • Multiple-action policing • Single-rate policing • Two-rate policing
Queueing and shaping	Supports the following: <ul style="list-style-type: none"> • Byte-based WRED • CBWFQ • Class-based shaping support on ATM PVCs • LLQ • random-detect discard-class-based command • WRED

Any Transport over MPLS (AToM) Remote Ethernet Port Shutdown

This Cisco IOS XE feature allows a service provider edge (PE) router on the local end of an Ethernet over MPLS (EoMPLS) pseudowire to detect a remote link failure and cause the shutdown of the Ethernet port on the local customer edge (CE) router. Because the Ethernet port on the local CE router is shut down, the router does not lose data by continuously sending traffic to the failed remote link. This is beneficial if the link is configured as a static IP route.

The figure below illustrates a condition in an EoMPLS WAN, with a down Layer 2 tunnel link between a CE router (Customer Edge 1) and the PE router (Provider Edge 1). A CE router on the far side of the Layer 2 tunnel (Customer Edge 2), continues to forward traffic to Customer Edge 1 through the L2 tunnel.

Figure 1: Remote Link Outage in EoMPLS WAN

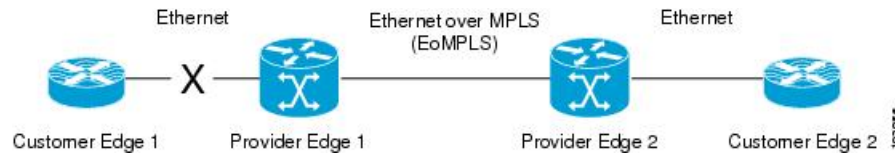

Previous to this feature, the Provider Edge 2 router could not detect a failed remote link. Traffic forwarded from Customer Edge 2 to Customer Edge 1 would be lost until routing or spanning tree protocols detected the down remote link. If the link was configured with static routing, the remote link outage would be even more difficult to detect.

With this feature, the Provider Edge 2 router detects the remote link failure and causes a shutdown of the local Customer Edge 2 Ethernet port. When the remote L2 tunnel link is restored, the local interface is automatically restored as well. The possibility of data loss is thus diminished.

With reference to the figure above, the Remote Ethernet Shutdown sequence is generally described as follows:

1. The remote link between Customer Edge 1 and Provider Edge 1 fails.
2. Provider Edge 2 detects the remote link failure and disables the transmit laser on the line card interface connected to Customer Edge 2.
3. An RX_LOS error alarm is received by Customer Edge 2 causing Customer Edge 2 to bring down the interface.
4. Provider Edge 2 maintains its interface with Customer Edge 2 in an up state.
5. When the remote link and EoMPLS connection is restored, the Provider Edge 2 router enables the transmit laser.
6. The Customer Edge 2 router brings up its downed interface.

This feature is enabled by default for Ethernet over MPLS (EoMPLS). You can also enable this feature by using the **remote link failure notification** command in xconnect configuration mode as shown in the following example:

```
pseudowire-class eompls
  encapsulation mpls
  !
interface GigabitEthernet1/0/0
  xconnect 10.13.13.13 1 pw-class eompls
    remote link failure notification
  !
```

This feature can be disabled using the **no remote link failure notification** command in xconnect configuration mode. Use the **show ip interface brief** privileged EXEC command to display the status of all remote L2 tunnel links. Use the **show interface** privileged EXEC command to show the status of the L2 tunnel on a specific interface.



Note The **no remote link failure notification** command will not give notification to clients for remote attachment circuit status down.



Note Remote Ethernet Port Shutdown is supported only on EFP with encapsulation default.

Any Transport over MPLS (AToM) Remote Ethernet Port Shutdown Using Commands Associated with L2VPN Protocol-Based Feature

This Cisco IOS XE feature allows a service provider edge (PE) router on the local end of an Ethernet over MPLS (EoMPLS) pseudowire to detect a remote link failure and cause the shutdown of the Ethernet port on the local customer edge (CE) router. Because the Ethernet port on the local CE router is shut down, the router does not lose data by continuously sending traffic to the failed remote link. This is beneficial if the link is configured as a static IP route.

The figure below illustrates a condition in an EoMPLS WAN, with a down Layer 2 tunnel link between a CE router (Customer Edge 1) and the PE router (Provider Edge 1). A CE router on the far side of the Layer 2 tunnel (Customer Edge 2), continues to forward traffic to Customer Edge 1 through the L2 tunnel.

Figure 2: Remote Link Outage in EoMPLS WAN

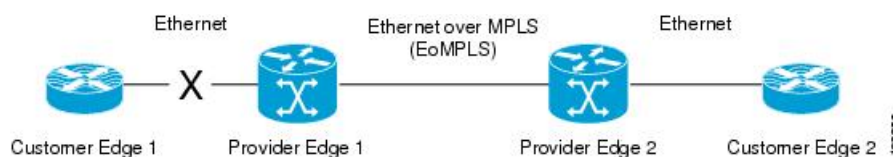

Previous to this feature, the Provider Edge 2 router could not detect a failed remote link. Traffic forwarded from Customer Edge 2 to Customer Edge 1 would be lost until routing or spanning tree protocols detected the down remote link. If the link was configured with static routing, the remote link outage would be even more difficult to detect.

With this feature, the Provider Edge 2 router detects the remote link failure and causes a shutdown of the local Customer Edge 2 Ethernet port. When the remote L2 tunnel link is restored, the local interface is automatically restored as well. The possibility of data loss is thus diminished.

With reference to the figure above, the Remote Ethernet Shutdown sequence is generally described as follows:

1. The remote link between Customer Edge 1 and Provider Edge 1 fails.
2. Provider Edge 2 detects the remote link failure and disables the transmit laser on the line card interface connected to Customer Edge 2.
3. An RX_LOS error alarm is received by Customer Edge 2 causing Customer Edge 2 to bring down the interface.
4. Provider Edge 2 maintains its interface with Customer Edge 2 in an up state.
5. When the remote link and EoMPLS connection is restored, the Provider Edge 2 router enables the transmit laser.
6. The Customer Edge 2 router brings up its downed interface.

This feature is enabled by default for Ethernet over MPLS (EoMPLS). You can also enable this feature by using the **remote link failure notification** command in xconnect configuration mode as shown in the following example:

```

template type pseudowire eompls
 encapsulation mpls
!
interface Pseudowire 100
 source template type pseudowire test
 neighbor 10.13.13.13 1
interface GigabitEthernet1/0/0
 service instance 300 ethernet
 encapsulation default
 xconnect 10.1.1.1 1 encapsulation mpls
 remote link failure notification
l2vpn xconnect context con1
 member GigabitEthernet1/0/0 service-instance 300
 member Pseudowire 100
!

l2vpn xconnect context con1
 member GigabitEthernet1/0/0 service-instance 300
 member Pseudowire 100
 remote link failure notification

```

This feature can be disabled using the **no remote link failure notification** command in xconnect configuration mode. Use the **show ip interface brief** privileged EXEC command to display the status of all remote L2 tunnel links. Use the **show interface** privileged EXEC command to show the status of the L2 tunnel on a specific interface.



Note The **no remote link failure notification** command will not give notification to clients for remote attachment circuit status down.

AToM Load Balancing with Single PW

Prior to Cisco IOS XE Release 3.4S, the Cisco ASR 1000 Series Aggregation Services Router did not perform load balancing for packets within the same pseudowire (PW) at the Provide Edge (PE) even if Equal Cost Multiple Paths (ECMPs) were available between PEs in an MPLS cloud. Only one of the routing options from the table would be used, and the other paths would be left unused.

The AToM Load Balancing with Single PW feature enables load balancing for packets within the same pseudowire by further classifying packets within the same pseudowire into different flows based on certain fields in the packet received on an attachment circuit. For example, for Ethernet this load balancing is based on the source MAC address in the incoming packets.

In Cisco IOS XE Release 3.4S, this feature is available only for the Ethernet family of attachment circuits (ACs); so the flow-identification logic is based on source MAC address. All packets with the same source MAC address follow one path and are identified as flows.

How to Configure Any Transport over MPLS

This section explains how to perform a basic AToM configuration and includes the following procedures:

Configuring the Pseudowire Class



Note In simple configurations, this task is optional. You need not specify a pseudowire class if you specify the tunneling method as part of the **xconnect** command.

- You must specify the **encapsulation mpls** command as part of the pseudowire class or as part of the **xconnect** command for the AToM VCs to work properly. If you omit the **encapsulation mpls** command as part of the **xconnect** command, you receive the following error:

```
% Incomplete command.
```

Procedure

Step 1 **enable**

Example:

```
Router> enable
```

Enables privileged EXEC mode.

- Enter your password if prompted.

Step 2 **configure terminal**

Example:

```
Router# configure terminal
```

Enters global configuration mode.

Step 3 **pseudowire-class *name***

Example:

```
Router(config)# pseudowire-class atom
```

Establishes a pseudowire class with a name that you specify and enters pseudowire class configuration mode.

Step 4 **encapsulation mpls**

Example:

```
Router(config-pw)# encapsulation mpls
```

Specifies the tunneling encapsulation.

Configuring the Pseudowire Class Using Commands Associated with L2VPN Protocol-Based Feature



Note In simple configurations, this task is optional. You need not specify a pseudowire class if you specify the tunneling method as part of the **l2vpn xconnect context** command.

- You must specify the **encapsulation mpls** command as part of the pseudowire class or as part of the **l2vpn xconnect context** command for the ATOM VCs to work properly. If you omit the **encapsulation mpls** command as part of the **l2vpn xconnect context** command, you receive the following error:

```
% Incomplete command.
```

Procedure

Step 1 enable

Example:

```
Router> enable
```

Enables privileged EXEC mode.

- Enter your password if prompted.

Step 2 configure terminal

Example:

```
Router# configure terminal
```

Enters global configuration mode.

Step 3 interface pseudowire *name*

Example:

```
Router(config)# interface pseudowire atom
```

Establishes an interface pseudowire with a name that you specify and enters pseudowire class configuration mode.

Step 4 encapsulation mpls

Example:

```
Router(config-pw-class)# encapsulation mpls
```

Specifies the tunneling encapsulation.

Step 5 neighbor *peer-address* *vcid-value*

Example:

```
Router(config-pw-class)# neighbor 33.33.33.33 1
```

Specifies the peer IP address and virtual circuit (VC) ID value of a Layer 2 VPN (L2VPN) pseudowire.

Changing the Encapsulation Type and Removing a Pseudowire

Once you specify the **encapsulation mpls** command, you cannot remove it using the **no encapsulation mpls** command.

Nor can you change the command's setting using the **encapsulation l2tpv3** command.

Those methods result in the following error message:

```
Encapsulation changes are not allowed on an existing pw-class.
```

To remove the **encapsulation mpls** command, you must delete the pseudowire with the **no pseudowire-class** command.

To change the type of encapsulation, remove the pseudowire using the **no pseudowire-class** command and reconfigure the pseudowire to specify the new encapsulation type.

Changing the Encapsulation Type and Removing a Pseudowire Using Commands Associated with the L2VPN Protocol-Based Feature

Once you specify the **encapsulation mpls** command, you cannot remove it using the **no encapsulation mpls** command.

Nor can you change the command's setting using the **encapsulation l2tpv3** command.

Those methods result in the following error message:

```
Encapsulation changes are not allowed on an existing pw-class.
```

```
% Cannot remove encapsulation on existing pseudowire
```

To remove the **encapsulation mpls** command, you must delete the pseudowire with the **no interface pseudowire** command.

To change the type of encapsulation, remove the pseudowire using the **no template type pseudowire** command and reconfigure the pseudowire to specify the new encapsulation type.

Configuring ATM AAL5 over MPLS

Configuring ATM AAL5 over MPLS on PVCs

Procedure

Step 1 **enable**

Example:

```
Router> enable
```

Enables privileged EXEC mode.

- Enter your password if prompted.

Step 2 **configure terminal**

Example:

```
Router# configure terminal
```

Enters global configuration mode.

Step 3 **interface** *type slot / subslot / port [.subinterface]*

Example:

```
Router(config)# interface atm1/0/0
```

Specifies the interface type and enters interface configuration mode.

Step 4 **pvc** [*name*] *vpi / vci l2transport*

Example:

```
Router(config-if)# pvc 1/200 l2transport
```

Creates or assigns a name to an ATM PVC and enters L2transport PVC configuration mode.

- The **l2transport** keyword indicates that the PVC is a switched PVC instead of a terminated PVC.

Step 5 **encapsulation aal5**

Example:

```
Router(config-if-atm-l2trans-pvc)# encapsulation aal5
```

Specifies ATM AAL5 encapsulation for the PVC. Make sure you specify the same encapsulation type on the PE and customer edge (CE) routers.

Step 6 **xconnect** *peer-router-id vcid encapsulation mpls*

Example:

```
Router(config-if-atm-l2trans-pvc)# xconnect 10.13.13.13 100 encapsulation mpls
```

Binds the attachment circuit to a pseudowire VC.

Step 7 **end**

Example:

```
Router(config-if-atm-l2trans-pvc)# end
```

Exits to privileged EXEC mode.

Step 8 **show mpls l2transport vc**

Example:

```
Router# show mpls l2transport vc
```

Displays output that shows ATM AAL5 over MPLS is configured on a PVC.

Examples

The following is sample output from the **show mpls l2transport vc** command that shows that ATM AAL5 over MPLS is configured on a PVC:

```
Router# show mpls l2transport vc
Local intf   Local circuit   Dest address   VC ID   Status
-----
ATM1/0      ATM AAL5 1/100 10.4.4.4      100     UP
```

Configuring ATM AAL5 over MPLS on PVCs using the commands associated with the L2VPN Protocol-Based CLIs feature

Procedure

Step 1 enable

Example:

```
Device> enable
```

Enables privileged EXEC mode.

- Enter your password if prompted.

Step 2 configure terminal

Example:

```
Device# configure terminal
```

Enters global configuration mode.

Step 3 interface *type slot / subslot / port* [. *subinterface*]

Example:

```
Device(config)# interface atm1/0/0
```

Specifies the interface type and enters interface configuration mode.

Step 4 pvc [*name*] *vpi / vci* l2transport

Example:

```
Device(config-if)# pvc 1/200 l2transport
```

Creates or assigns a name to an ATM PVC and enters L2transport PVC configuration mode.

- The **l2transport** keyword indicates that the PVC is a switched PVC instead of a terminated PVC.

Step 5 **encapsulation aal5****Example:**

```
Device(config-if-atm-l2trans-pvc)# encapsulation aal5
```

Specifies ATM AAL5 encapsulation for the PVC. Make sure you specify the same encapsulation type on the PE and customer edge (CE) routers.

Step 6 **end****Example:**

```
Device(config-if-atm-l2trans-pvc)# end
```

Exits to privileged EXEC mode.

Step 7 **interface pseudowire *number*****Example:**

```
Device(config)# interface pseudowire 100
```

Specifies the pseudowire interface and enters interface configuration mode.

Step 8 **encapsulation mpls****Example:**

```
Device(config-if)# encapsulation mpls
```

Specifies that Multiprotocol Label Switching (MPLS) is used as the data encapsulation method.

Step 9 **neighbor *peer-address vcid-value*****Example:**

```
Device(config-if)# neighbor 10.13.13.13 100
```

Specifies the peer IP address and virtual circuit (VC) ID value of the Layer 2 VPN (L2VPN) pseudowire.

Step 10 **exit****Example:**

```
Device(config-if)# exit
```

Exits interface configuration mode.

Step 11 **l2vpn xconnect context *context-name*****Example:**

```
Device(config)# l2vpn xconnect context con1
```

Creates a Layer 2 VPN (L2VPN) cross connect context and enters xconnect configuration mode.

Step 12 **member pseudowire *interface-number***

Example:

```
Device(config-xconnect)# member pseudowire 100
```

Specifies a member pseudowire to form a Layer 2 VPN (L2VPN) cross connect.

Step 13 **member atm** *interface-number* **pvc** *vpi / vci***Example:**

```
Device(config-xconnect)# member atm 100 pvc 1/200
```

Specifies the location of the ATM member interface.

Step 14 **end****Example:**

```
Device(config-xconnect)# end
```

Exits to privileged EXEC mode.

Step 15 **show l2vpn atom vc****Example:**

```
Device# show l2vpn atom vc
```

Displays output that shows ATM AAL5 over MPLS is configured on a PVC.

Examples

The following is sample output from the **show l2vpn atom vc** command that shows that ATM AAL5 over MPLS is configured on a PVC:

```
Device# show l2vpn atom vc
Local intf   Local circuit   Dest address   VC ID   Status
-----
ATM1/0      ATM AAL5 1/100 10.4.4.4      100     UP
```

Configuring ATM AAL5 over MPLS in VC Class Configuration Mode

Procedure**Step 1** **enable****Example:**

```
Router> enable
```

Enables privileged EXEC mode.

- Enter your password if prompted.

Step 2 **configure terminal****Example:**

```
Router# configure terminal
```

Enters global configuration mode.

Step 3 **vc-class atm** *vc-class-name***Example:**

```
Router(config)# vc-class atm aal5class
```

Creates a VC class and enters VC class configuration mode.

Step 4 **encapsulation** *layer-type***Example:**

```
Router(config-vc-class)# encapsulation aal5
```

Configures the AAL and encapsulation type.

Step 5 **exit****Example:**

```
Router(config-vc-class)# exit
```

Exits VC class configuration mode.

Step 6 **interface** *type slot / subslot / port* [*.subinterface*]**Example:**

```
Router(config)# interface atm1/0/0
```

Specifies the interface type enters interface configuration mode.

Step 7 **class-int** *vc-class-name***Example:**

```
Router(config-if)# class-int aal5class
```

Applies a VC class to the ATM main interface or subinterface.

Note You can also apply a VC class to a PVC.

Step 8 **pvc** [*name*] *vpi / vci* **l2transport****Example:**

```
Router(config-if)# pvc 1/200 l2transport
```

Creates or assigns a name to an ATM PVC and enters L2transport PVC configuration mode.

- The **l2transport** keyword indicates that the PVC is a switched PVC instead of a terminated PVC.

Step 9 **xconnect** *peer-router-id vcid* **encapsulation mpls**

Example:

```
Router(config-if-atm-l2trans-pvc)# xconnect 10.13.13.13 100 encapsulation mpls
```

Binds the attachment circuit to a pseudowire VC.

Step 10 **end**

Example:

```
Router(config-if-atm-l2trans-pvc)# end
```

Exits to privileged EXEC mode.

Step 11 **show atm class-links**

Example:

```
Router# show atm class-links
```

Displays the type of encapsulation and that the VC class was applied to an interface.

Examples

In the following example, the command output from the **show atm class-links** command verifies that ATM AAL5 over MPLS is configured as part of a VC class. The command output shows the type of encapsulation and that the VC class was applied to an interface.

```
Router# show atm class-links 1/100
Displaying vc-class inheritance for ATM1/0/0.0, vc 1/100:
no broadcast - Not configured - using default
encapsulation aal5 - VC-class configured on main interface
```

Configuring ATM AAL5 over MPLS in VC Class Configuration Mode using the commands associated with the L2VPN Protocol-Based CLIs feature

Procedure

Step 1 **enable**

Example:

```
Router> enable
```

Enables privileged EXEC mode.

- Enter your password if prompted.

Step 2 **configure terminal**

Example:

```
Router# configure terminal
```

Enters global configuration mode.

Step 3 **vc-class atm** *vc-class-name*

Example:

```
Router(config)# vc-class atm aal5class
```

Creates a VC class and enters VC class configuration mode.

Step 4 **encapsulation** *layer-type*

Example:

```
Router(config-vc-class)# encapsulation aal5
```

Configures the AAL and encapsulation type.

Step 5 **exit**

Example:

```
Router(config-vc-class)# exit
```

Exits VC class configuration mode.

Step 6 **interface** *type slot / subslot / port* [*.subinterface*]

Example:

```
Router(config)# interface atm1/0/0
```

Specifies the interface type enters interface configuration mode.

Step 7 **class-int** *vc-class-name*

Example:

```
Router(config-if)# class-int aal5class
```

Applies a VC class to the ATM main interface or subinterface.

Note You can also apply a VC class to a PVC.

Step 8 **pvc** [*name*] *vpi / vci l2transport*

Example:

```
Router(config-if)# pvc 1/200 l2transport
```

Creates or assigns a name to an ATM PVC and enters L2transport PVC configuration mode.

- The **l2transport** keyword indicates that the PVC is a switched PVC instead of a terminated PVC.

Step 9 **exit**

Example:

```
Router(config-if)# exit
```

Exits interface configuration mode.

Step 10 **interface pseudowire** *number***Example:**

```
Router(config)# interface pseudowire 100
```

Specifies the pseudowire interface and enters interface configuration mode.

Step 11 **encapsulation mpls****Example:**

```
Router(config-if)# encapsulation mpls
```

Specifies that Multiprotocol Label Switching (MPLS) is used as the data encapsulation method.

Step 12 **neighbor** *peer-address vcid-value***Example:**

```
Router(config-if)# neighbor 10.0.0.1 123
```

Specifies the peer IP address and virtual circuit (VC) ID value of the Layer 2 VPN (L2VPN) pseudowire.

Step 13 **exit****Example:**

```
Router(config-if)# exit
```

Exits interface configuration mode.

Step 14 **l2vpn xconnect context** *context-name***Example:**

```
Router(config)# l2vpn xconnect context con1
```

Creates a Layer 2 VPN (L2VPN) cross connect context and enters xconnect configuration mode.

Step 15 **member pseudowire** *interface-number***Example:**

```
Router(config-xconnect)# member pseudowire 100
```

Specifies a member pseudowire to form a Layer 2 VPN (L2VPN) cross connect.

Step 16 **member atm** *interface-number***Example:**

```
Device(config-xconnect)# member atm 100
```

Specifies the location of the ATM member interface.

Step 17 **end**

Example:

```
Router(config-if-atm-l2trans-pvc)# end
```

Exits to privileged EXEC mode.

Step 18 **show atm class-links**

Example:

```
Router# show atm class-links
```

Displays the type of encapsulation and that the VC class was applied to an interface.

Examples

In the following example, the command output from the **show atm class-links** command verifies that ATM AAL5 over MPLS is configured as part of a VC class. The command output shows the type of encapsulation and that the VC class was applied to an interface.

```
Router# show atm class-links 1/100
Displaying vc-class inheritance for ATM1/0/0.0, vc 1/100:
no broadcast - Not configured - using default
encapsulation aal5 - VC-class configured on main interface
```

Configuring Ethernet over MPLS

Configuring Ethernet over MPLS in VLAN Mode to Connect Two VLAN Networks That Are in Different Locations.

Procedure

Step 1 **enable**

Example:

```
Router> enable
```

Enables privileged EXEC mode.

- Enter your password if prompted.

Step 2 **configure terminal**

Example:

```
Router# configure terminal
```

Enters global configuration mode.

Step 3 `interface gigabitethernet slot / subslot / port [. subinterface]`

Example:

```
Router(config)# interface gigabitethernet4/0/0.1
```

Specifies the Gigabit Ethernet subinterface and enters subinterface configuration mode.

- Make sure the subinterface on the adjoining CE router is on the same VLAN as this PE router.

Step 4 `encapsulation dot1q vlan-id`

Example:

```
Router(config-subif)# encapsulation dot1q 100
```

Enables the subinterface to accept 802.1Q VLAN packets.

Step 5 `xconnect peer-router-id vcid encapsulation mpls`

Example:

```
Router(config-subif)# xconnect 10.0.0.1 123 encapsulation mpls
```

Binds the attachment circuit to a pseudowire VC.

Configuring Ethernet over MPLS in VLAN Mode to Connect Two VLAN Networks That Are in Different Locations using the commands associated with the L2VPN Protocol-Based CLIs feature

Procedure

Step 1 `enable`

Example:

```
Router> enable
```

Enables privileged EXEC mode.

- Enter your password if prompted.

Step 2 `configure terminal`

Example:

```
Router# configure terminal
```

Enters global configuration mode.

Step 3 `interface gigabitethernet slot / subslot / port [. subinterface]`

Example:

```
Router(config)# interface gigabitethernet4/0/0.1
```

Specifies the Gigabit Ethernet subinterface and enters subinterface configuration mode.

- Make sure the subinterface on the adjoining CE router is on the same VLAN as this PE router.

Step 4 **encapsulation dot1q** *vlan-id*

Example:

```
Router(config-subif)# encapsulation dot1q 100
```

Enables the subinterface to accept 802.1Q VLAN packets.

Step 5 **end**

Example:

```
Router(config-subif)# end
```

Exits to privileged EXEC mode.

Step 6 **interface pseudowire** *number*

Example:

```
Router(config)# interface pseudowire 100
```

Specifies the pseudowire interface and enters interface configuration mode.

Step 7 **encapsulation mpls**

Example:

```
Router(config-if)# encapsulation mpls
```

Specifies that Multiprotocol Label Switching (MPLS) is used as the data encapsulation method.

Step 8 **neighbor** *peer-address vcid-value*

Example:

```
Router(config-if)# neighbor 10.0.0.1 123
```

Specifies the peer IP address and virtual circuit (VC) ID value of the Layer 2 VPN (L2VPN) pseudowire.

Step 9 **exit**

Example:

```
Router(config-if)# exit
```

Exits interface configuration mode.

Step 10 **l2vpn xconnect context** *context-name*

Example:

```
Router(config)# l2vpn xconnect context con1
```

Creates a Layer 2 VPN (L2VPN) cross connect context and enters xconnect configuration mode.

Step 11 **member pseudowire** *interface-number*

Example:

```
Router(config-xconnect)# member pseudowire 100
```

Specifies a member pseudowire to form a Layer 2 VPN (L2VPN) cross connect.

Step 12 **member gigabitethernet** *interface-number*

Example:

```
Router(config-xconnect)# member GigabitEthernet0/0/0.1
```

Specifies the location of the Gigabit Ethernet member interface.

Step 13 **end**

Example:

```
Router(config-xconnect)# end
```

Exits to privileged EXEC mode.

Configuring Ethernet over MPLS in Port Mode

Procedure

Step 1 **enable**

Example:

```
Router> enable
```

Enables privileged EXEC mode.

- Enter your password if prompted.

Step 2 **configure terminal**

Example:

```
Router# configure terminal
```

Enters global configuration mode.

Step 3 **interface gigabitethernet** *slot / subslot / port [.subinterface]*

Example:

```
Router(config)# interface gigabitethernet4/0/0
```

```
Router(config)# interface gigabitethernet 0/2/4
```

Specifies the Gigabit Ethernet interface and enters interface configuration mode.

- Make sure the interface on the adjoining CE router is on the same VLAN as this PE router.

Step 4 **no ip address****Example:**

```
Router(config-if)# no ip address
```

Specifies that there is no IP address assigned to the interface.

Step 5 **negotiation auto****Example:**

```
Router(config-if)# negotiation auto
```

Enables the auto negotiation protocol.

Step 6 **service instance *id* ethernet****Example:**

```
Router(config-if)# service instance 100 ethernet
```

Configures an ethernet service instance on an interface and enters service instance configuration mode.

Step 7 **xconnect *peer-router-id vcid* encapsulation mpls****Example:**

```
Router(config-if)# xconnect 10.0.0.1 123 encapsulation mpls
```

Binds the attachment circuit to a pseudowire VC.

Step 8 **end****Example:**

```
Router(config-if)# end
```

Exits to privileged EXEC mode.

Step 9 **show mpls l2transport vc****Example:**

```
Router# show mpls l2transport vc
```

Displays information about Ethernet over MPLS port mode.

Examples

The sample output in the following example shows two VCs for Ethernet over MPLS:

- VC 2 is in Ethernet VLAN mode.
- VC 8 is in Ethernet port mode.

```
Router# show mpls l2transport vc
Local intf      Local circuit    Dest address     VC ID      Status
```

```

-----
Gi4/0/0.1      Eth VLAN 2      10.1.1.1      2      UP
Gi8/0/1       Ethernet        10.1.1.1      8      UP

```

The sample output from the **show mpls l2transport vc detail** command displays the same information in a different format:

```

Router# show mpls l2transport vc detail
Local interface: Gi4/0/0.1 up, line protocol up, Eth VLAN 2 up
Destination address: 10.1.1.1, VC ID: 2, VC status: up
.
.
.
Local interface: Gi8/0/1 up, line protocol up, Ethernet up
Destination address: 10.1.1.1, VC ID: 8, VC status: up

```

Configuring Ethernet over MPLS in Port Mode Using Commands Associated with the L2VPN Protocol-Based Feature

Procedure

Step 1 enable

Example:

```
Device> enable
```

Enables privileged EXEC mode.

- Enter your password if prompted.

Step 2 configure terminal

Example:

```
Device# configure terminal
```

Enters global configuration mode.

Step 3 interface gigabitethernet slot / subslot / port[. subinterface]

Example:

```
Device(config)# interface gigabitethernet4/0/0
```

Specifies the Gigabit Ethernet interface and enters interface configuration mode.

- Make sure the interface on the adjoining CE router is on the same VLAN as this PE router.

Step 4 end

Example:

```
Device(config-if)# end
```

Exits to privileged EXEC mode.

Step 5 **interface pseudowire** *number***Example:**

```
Device(config)# interface pseudowire 100
```

Specifies the pseudowire interface and enters interface configuration mode.

Step 6 **encapsulation mpls****Example:**

```
Device(config-if)# encapsulation mpls
```

Specifies that Multiprotocol Label Switching (MPLS) is used as the data encapsulation method.

Step 7 **neighbor** *peer-address vcid-value***Example:**

```
Device(config-if)# neighbor 10.0.0.1 123
```

Specifies the peer IP address and virtual circuit (VC) ID value of the Layer 2 VPN (L2VPN) pseudowire.

Step 8 **exit****Example:**

```
Device(config-if)# exit
```

Exits interface configuration mode.

Step 9 **l2vpn xconnect context** *context-name***Example:**

```
Device(config)# l2vpn xconnect context con1
```

Creates a Layer 2 VPN (L2VPN) cross connect context and enters xconnect configuration mode.

Step 10 **member pseudowire** *interface-number***Example:**

```
Device(config-xconnect)# member pseudowire 100
```

Specifies a member pseudowire to form a Layer 2 VPN (L2VPN) cross connect.

Step 11 **member gigabitethernet** *interface-number***Example:**

```
Device(config-xconnect)# member GigabitEthernet0/0/0.1
```

Specifies the location of the Gigabit Ethernet member interface.

Step 12 **end****Example:**

```
Device(config-xconnect)# end
```

Exits to privileged EXEC mode.

Step 13 **end**

Example:

```
Device(config-if)# end
```

Exits to privileged EXEC mode.

Step 14 **show l2vpn atom vc**

Example:

```
Device# show l2vpn atom vc
```

Displays information about Ethernet over MPLS port mode.

Examples

The sample output in the following example shows two VCs for Ethernet over MPLS:

- VC 2 is in Ethernet VLAN mode.
- VC 8 is in Ethernet port mode.

```
Device# show l2vpn atom vc
Service Interface   Dest Address   VC ID   Type   Name   Status
-----
pw100              10.1.1.1      2       p2p    FOO    UP
pw200              10.1.1.1      8       p2p    FOO    UP
```

Configuring Ethernet over MPLS with VLAN ID Rewrite

Procedure

Step 1 **enable**

Example:

```
Router> enable
```

Enables privileged EXEC mode.

- Enter your password if prompted.

Step 2 **configure terminal**

Example:

```
Router# configure terminal
```

Enters global configuration mode.

Step 3 **interface gigabitethernet** *slot / subslot / port [. subinterface]*

Example:

```
Router(config)# interface gigabitethernet4/0/0.1
```

```
Router(config)# interface GigabitEthernet0/2/4
```

Specifies the Gigabit Ethernet subinterface and enters subinterface configuration mode.

Step 4 **no ip address**

Example:

```
Router(config-if)# no ip address
```

Specifies that there is no IP address assigned to the interface.

Step 5 **negotiation auto**

Example:

```
Router(config-if)# negotiation auto
```

Enables the auto negotiation protocol.

Step 6 **service instance** *id* **ethernet**

Example:

```
Router(config-if)# service instance 100 ethernet
```

Configures an ethernet service instance on an interface and enters service instance configuration mode.

Step 7 **encapsulation dot1q** *vlan-id*

Example:

```
Router(config-subif)# encapsulation dot1q 100
```

Enables the subinterface to accept 802.1Q VLAN packets.

Step 8 **xconnect** *peer-router-id vcid* **encapsulation mpls**

Example:

```
Router(config-subif)# xconnect 10.0.0.1 123 encapsulation mpls
```

Binds the attachment circuit to a pseudowire VC and enters xconnect configuration mode.

Step 9 **remote circuit id** *remote-vlan-id*

Example:

```
Router(config-subif-xconn)# remote circuit id 101
```

(Optional) Enables you to use VLAN interfaces with different VLAN IDs at both ends of the tunnel.

Step 10 **end**

Example:

```
Router(config-subif-xconn)# end
```

Exits to privileged EXEC mode.

Step 11 show controllers eompls forwarding-table

Example:

```
Router# show controllers eompls forwarding-table
```

Displays information about VLAN ID rewrite.

Examples

On PE1

On PE2

The following sample output from the **show controllers eompls forwarding-table** command shows VLAN ID rewrite configured on a router with an engine 2 3-port Gigabit Ethernet line card. In this example, the output in boldface font shows the VLAN ID rewrite information.

```
Router# execute slot 0 show controllers eompls forwarding-table 0 2
Port # 0, VLAN-ID # 2, Table-index 2
EoMPLS configured: 1
tag_rew_ptr          = D001BB58
Leaf entry?         = 1
FCR index           = 20
    **tagrew_psa_addr = 0006ED60
    **tagrew_vir_addr = 7006ED60
    **tagrew_phy_addr = F006ED60
    [0-7] loq 8800 mtu 4458 oq 4000 ai 3 oi 04019110 (encaps size 4)
    cw-size 4 vlanid-rew 3
    gather A30 (bufhdr size 32 EoMPLS (Control Word) Imposition profile 81)
    2 tag: 18 18
    counters 1182, 10 reported 1182, 10.
Local OutputQ (Unicast): Slot:2 Port:0 RED queue:0 COS queue:0
Output Q (Unicast):      Port:0      RED queue:0 COS queue:0
```

```
Router# execute slot 0 show controllers eompls forwarding-table 0 3
Port # 0, VLAN-ID # 3, Table-index 3
EoMPLS configured: 1
tag_rew_ptr          = D0027B90
Leaf entry?         = 1
FCR index           = 20
    **tagrew_psa_addr = 0009EE40
    **tagrew_vir_addr = 7009EE40
    **tagrew_phy_addr = F009EE40
    [0-7] loq 9400 mtu 4458 oq 4000 ai 8 oi 84000002 (encaps size 4)
    cw-size 4 vlanid-rew 2
    gather A30 (bufhdr size 32 EoMPLS (Control Word) Imposition profile 81)
    2 tag: 17 18
    counters 1182, 10 reported 1182, 10.
Local OutputQ (Unicast): Slot:5 Port:0 RED queue:0 COS queue:0
Output Q (Unicast):      Port:0      RED queue:0 COS queue:0
```

Configuring Ethernet over MPLS with VLAN ID Rewrite Using Commands Associated with the L2VPN Protocol-Based Feature

Procedure

Step 1

enable

Example:

```
Router> enable
```

Enables privileged EXEC mode.

- Enter your password if prompted.

Step 2

configure terminal

Example:

```
Router# configure terminal
```

Enters global configuration mode.

Step 3

interface gigabitethernet slot / subslot / port [.subinterface]

Example:

```
Router(config)# interface gigabitethernet4/0/0.1
```

Specifies the Gigabit Ethernet subinterface and enters subinterface configuration mode.

Step 4

interface gigabitethernet slot / subslot / port

Example:

```
Router(config)# interface gigabitethernet4/0/0
```

Specifies the Gigabit Ethernet subinterface and enters subinterface configuration mode.

Step 5

service instance number ethernet number

Example:

```
Router(config-if)#service instance 393 ethernet
```

Step 6

encapsulation dot1q vlan-id

Example:

```
Router(config-subif)# encapsulation dot1q 100
```

Enables the subinterface to accept 802.1Q VLAN packets.

Step 7

end

Example:

```
Router(config-subif)# end
```

Exits to privileged EXEC mode.

Step 8 **interface pseudowire** *number*

Example:

```
Router(config)# interface pseudowire 100
```

Specifies the pseudowire interface and enters interface configuration mode.

Step 9 **encapsulation mpls**

Example:

```
Router(config-if)# encapsulation mpls
```

Specifies that Multiprotocol Label Switching (MPLS) is used as the data encapsulation method.

Step 10 **neighbor** *peer-address vcid-value*

Example:

```
Router(config-if)# neighbor 10.0.0.1 123
```

Specifies the peer IP address and virtual circuit (VC) ID value of the Layer 2 VPN (L2VPN) pseudowire.

Step 11 **exit**

Example:

```
Router(config-if)# exit
```

Exits interface configuration mode.

Step 12 **l2vpn xconnect context** *context-name*

Example:

```
Router(config)# l2vpn xconnect context con1
```

Creates a Layer 2 VPN (L2VPN) cross connect context and enters xconnect configuration mode.

Step 13 **member pseudowire** *interface-number*

Example:

```
Router(config-xconnect)# member pseudowire 100
```

Specifies a member pseudowire to form a Layer 2 VPN (L2VPN) cross connect.

Step 14 **member gigabitethernet** *interface-number*

Example:

```
Router(config-xconnect)# member GigabitEthernet0/0/0.1
```

```
Router(config-xconnect)# member gigabitethernet4/0/0 service-instance 393
```

Specifies the location of the Gigabit Ethernet member interface.

Step 15 **remote circuit id** *remote-vlan-id*

Example:

```
Router(config-xconnect)# remote circuit id 101
```

(Optional) Enables you to use VLAN interfaces with different VLAN IDs at both ends of the tunnel.

Step 16 **end****Example:**

```
Router(config-xconnect)# end
```

Exits to privileged EXEC mode.

Step 17 **show controllers eompls forwarding-table****Example:**

```
Router# show controllers eompls forwarding-table
```

Displays information about VLAN ID rewrite.

ExamplesExample**On PE1****On PE2**

```
RSP3-RT1#show ethernet service instance id HYPERLINK "tel:1002"1002 interface gi 0/1/0 det
Service Instance ID: HYPERLINK "tel:1002"1002
Service Instance Type: Static
Associated Interface: GigabitEthernet0/1/0
Associated EVC:
L2protocol drop
CE-Vlans:
Encapsulation: dot1q HYPERLINK "tel:1002"1002 vlan protocol type 0xHYPERLINK "tel:8100"8100
Rewrite: ingress tag pop 1 symmetric
Interface Dot1q Tunnel Ethertype: 0xHYPERLINK "tel:8100"8100
State: Up
EFP Statistics:
Pkts In   Bytes In   Pkts Out  Bytes Out
0         0         0         0

RSP3-RT1#
```

The following sample output from the **show controllers eompls forwarding-table** command shows VLAN ID rewrite configured on a router with an engine 2 3-port Gigabit Ethernet line card. In this example, the output in boldface font shows the VLAN ID rewrite information.

```
Router# execute slot 0 show controllers eompls forwarding-table 0 2
Port # 0, VLAN-ID # 2, Table-index 2
EoMPLS configured: 1
tag_rew_ptr           = D001BB58
Leaf entry?           = 1
FCR index              = 20
**tagrew_psa_addr     = 0006ED60
**tagrew_vir_addr     = 7006ED60
```

```

**tagrew_phy_addr    = F006ED60
[0-7] loq 8800 mtu 4458 oq 4000 ai 3 oi 04019110 (encaps size 4)
cw-size 4 vlanid-rew 3
gather A30 (bufhdr size 32 EoMPLS (Control Word) Imposition profile 81)
2 tag: 18 18
counters 1182, 10 reported 1182, 10.
Local OutputQ (Unicast): Slot:2 Port:0 RED queue:0 COS queue:0
Output Q (Unicast):      Port:0      RED queue:0 COS queue:0

```

```

Router# execute slot 0 show controllers eompls forwarding-table 0 3
Port # 0, VLAN-ID # 3, Table-index 3
EoMPLS configured: 1
tag_rew_ptr          = D0027B90
Leaf entry?         = 1
FCR index           = 20
**tagrew_psa_addr    = 0009EE40
**tagrew_vir_addr    = 7009EE40
**tagrew_phy_addr    = F009EE40
[0-7] loq 9400 mtu 4458 oq 4000 ai 8 oi 84000002 (encaps size 4)
cw-size 4 vlanid-rew 2
gather A30 (bufhdr size 32 EoMPLS (Control Word) Imposition profile 81)
2 tag: 17 18
counters 1182, 10 reported 1182, 10.
Local OutputQ (Unicast): Slot:5 Port:0 RED queue:0 COS queue:0
Output Q (Unicast):      Port:0      RED queue:0 COS queue:0

```

Configuring Tunnel Selection

Procedure

Step 1 **enable**

Example:

```
Router> enable
```

Enables privileged EXEC mode.

- Enter your password if prompted.

Step 2 **configure terminal**

Example:

```
Router# configure terminal
```

Enters global configuration mode.

Step 3 **pseudowire-class name**

Example:

```
Router(config)# pseudowire-class tsl
```

Establishes a pseudowire class with a name that you specify and enters pseudowire configuration mode.

Step 4 **encapsulation mpls**

Example:

```
Router(config-pw)# encapsulation mpls
```

Specifies the tunneling encapsulation. For AToM, the encapsulation type is mpls.

Step 5 **preferred-path** {**interface tunnel** *tunnel-number* | **peer** {*ip-address* | *host-name*}} [**disable-fallback**]

Example:

```
Router(config-pw)# preferred path peer 10.18.18.18
```

Specifies the MPLS traffic engineering tunnel or IP address or hostname to be used as the preferred path.

Step 6 **exit**

Example:

```
Router(config-pw)# exit
```

Exits from pseudowire configuration mode and enables the Tunnel Selection feature.

Step 7 **interface** *type slot / subslot / port*

Example:

```
Router(config)# interface atm1/1/0
```

Specifies an interface type and enters interface configuration mode.

Step 8 **encapsulation** *encapsulation-type*

Example:

```
Router(config-if)# encapsulation aal5
```

Specifies the encapsulation for the interface.

Step 9 **xconnect** *peer-router-id vcid pw-class name*

Example:

```
Router(config-if)# xconnect 10.0.0.1 123 pw-class ts1
```

Binds the attachment circuit to a pseudowire VC.

Examples

In the following sample output from the **show mpls l2transport vc** command includes the following information about the VCs:

- VC 101 has been assigned a preferred path called Tunnel1. The default path is disabled, because the preferred path specified that the default path should not be used if the preferred path fails.
- VC 150 has been assigned an IP address of a loopback address on PE2. The default path can be used if the preferred path fails.

Command output that is in boldface font shows the preferred path information.

```
Router# show mpls l2transport vc detail
Local interface: Gi0/0/0.1 up, line protocol up, Eth VLAN 222 up
  Destination address: 10.16.16.16, VC ID: 101, VC status: up
    Preferred path: Tunnell1, active
    Default path: disabled
    Tunnel label: 3, next hop point2point
    Output interface: Tu1, imposed label stack {17 16}
    Create time: 00:27:31, last status change time: 00:27:31
    Signaling protocol: LDP, peer 10.16.16.16:0 up
    MPLS VC labels: local 25, remote 16
    Group ID: local 0, remote 6
    MTU: local 1500, remote 1500
    Remote interface description:
    Sequencing: receive disabled, send disabled
    VC statistics:
      packet totals: receive 10, send 10
      byte totals:   receive 1260, send 1300
      packet drops: receive 0, send 0
Local interface: ATM1/0/0 up, line protocol up, ATM AAL5 0/50 up
  Destination address: 10.16.16.16, VC ID: 150, VC status: up
    Preferred path: 10.18.18.18, active
    Default path: ready
    Tunnel label: 3, next hop point2point
    Output interface: Tu2, imposed label stack {18 24}
    Create time: 00:15:08, last status change time: 00:07:37
    Signaling protocol: LDP, peer 10.16.16.16:0 up
    MPLS VC labels: local 26, remote 24
    Group ID: local 2, remote 0
    MTU: local 4470, remote 4470
    Remote interface description:
    Sequencing: receive disabled, send disabled
    VC statistics:
      packet totals: receive 0, send 0
      byte totals:   receive 0, send 0
      packet drops: receive 0, send 0
```

Troubleshooting Tips

To debug ATM cell packing, issue the **debug atm cell-packing** command.

Configuring Tunnel Selection Using Commands Associated with L2VPN Protocol-Based Feature

Procedure

Step 1

enable

Example:

```
Router> enable
```

Enables privileged EXEC mode.

- Enter your password if prompted.

Step 2 **configure terminal****Example:**

```
Router# configure terminal
```

Enters global configuration mode.

Step 3 **template type pseudowire *name*****Example:**

```
Router(config)# template type pseudowire ts1
```

Creates a template pseudowire with a name that you specify and enters pseudowire configuration mode.

Step 4 **encapsulation mpls****Example:**

```
Router(config-pw)# encapsulation mpls
```

Specifies the tunneling encapsulation. For AToM, the encapsulation type is mpls.

Step 5 **preferred-path {interface tunnel *tunnel-number* | peer {*ip-address* | *hostname*}} [disable-fallback]****Example:**

```
Router(config-pw)# preferred path peer 10.18.18.18
```

Specifies the MPLS traffic engineering tunnel or IP address or hostname to be used as the preferred path.

Step 6 **exit****Example:**

```
Router(config-pw)# exit
```

Exits from pseudowire configuration mode and enables the Tunnel Selection feature.

Step 7 **interface type slot / subslot / port[. subinterface]****Example:**

```
Router(config)# interface atm1/1/0
```

Specifies an interface type and enters interface configuration mode.

Step 8 **encapsulation *encapsulation-type*****Example:**

```
Router(config-if)# encapsulation aal5
```

Specifies the encapsulation for the interface.

Step 9 **end****Example:**

```
Router(config-if)# end
```

Exits to privileged EXEC mode.

Step 10 **interface pseudowire** *number*

Example:

```
Router(config)# interface pseudowire 100
```

Specifies the pseudowire interface and enters interface configuration mode.

Step 11 **source template type pseudowire** *name*

Example:

```
Router(config-if)# source template type pseudowire ts1
```

Configures the source template of type pseudowire named ts1.

Step 12 **neighbor** *peer-address* *vcid-value*

Example:

```
Router(config-if)# neighbor 10.0.0.1 123
```

Specifies the peer IP address and virtual circuit (VC) ID value of a Layer 2 VPN (L2VPN) pseudowire.

Step 13 **end**

Example:

```
Router(config-if)# end
```

Exits to privileged EXEC mode.

Step 14 **l2vpn xconnect context** *context-name*

Example:

```
Router(config)# l2vpn xconnect context con1
```

Creates a Layer 2 VPN (L2VPN) cross connect context and enters xconnect configuration mode.

Step 15 **member pseudowire** *interface-number*

Example:

```
Router(config-xconnect)# member pseudowire 100
```

Specifies a member pseudowire to form a Layer 2 VPN (L2VPN) cross connect.

Step 16 **member** *ip-address* *vc-id* **encapsulation mpls**

Example:

```
Router(config-xconnect)# member 10.0.0.1 123 encapsulation mpls
```

Creates the VC to transport the Layer 2 packets.

Step 17 **end**

Example:

```
Router(config-xconnect)# end
```

Exits to privileged EXEC mode.

Troubleshooting Tips using the commands associated with the L2VPN Protocol-Based CLIs feature

You can use the **debug l2vpn atom vc event** command to troubleshoot tunnel selection. For example, if the tunnel interface that is used for the preferred path is shut down, the default path is enabled. The **debug l2vpn atom vc event** command provides the following output:

```
AToM SMGR [10.2.2.2, 101]: Processing imposition update, vc_handle 62091860, update_action
 3, remote_vc_label 16
AToM SMGR [10.2.2.2, 101]: selected route no parent rewrite: tunnel not up
AToM SMGR [10.2.2.2, 101]: Imposition Programmed, Output Interface: Et3/2
```

Setting Experimental Bits with AToM



Note Only EoMPLS and CEM is supported .

Procedure

Step 1

enable

Example:

```
Router> enable
```

Enables privileged EXEC mode.

- Enter your password if prompted.

Step 2

configure terminal

Example:

```
Router# configure terminal
```

Enters global configuration mode.

Step 3

class-map *class-name*

Example:

```
Router(config)# class-map class1
```

Specifies the user-defined name of the traffic class and enters class map configuration mode.

Step 4

match any

Example:

```
Router(config-cmap)# match any
```

Specifies that all packets will be matched. Use only the **any** keyword. Other keywords might cause unexpected results.

Step 5 **policy-map** *policy-name*

Example:

```
Router(config-cmap)# policy-map policy1
```

Specifies the name of the traffic policy to configure and enters policy-map configuration mode.

Step 6 **class** *class-name*

Example:

```
Router(config-pmap)# class class1
```

Specifies the name of a predefined traffic class, which was configured with the **class-map** command, used to classify traffic to the traffic policy and enters policy-map class configuration mode.

Step 7 **set mpls experimental** *value*

Example:

```
Router(config-pmap-c)# set mpls experimental 7
```

Designates the value to which the MPLS bits are set if the packets match the specified policy map.

Step 8 **exit**

Example:

```
Router(config-pmap-c)# exit
```

Exits policy-map class configuration mode.

Step 9 **exit**

Example:

```
Router(config-pmap)# exit
```

Exits policy-map configuration mode.

Step 10 **interface** *type slot / subslot / port*

Example:

```
Router(config)# interface atm1/0/0
```

Specifies the interface type and enters interface configuration mode.

Step 11 **service-policy input** *policy-name*

Example:

```
Router(config-if)# service-policy input policy1
```

Attaches a traffic policy to an interface.

Step 12 **end**

Example:

```
Router(config-if)# end
```

Exits to privileged EXEC mode.

Step 13 **show policy-map interface** *interface-name* [*vc [vpi /] vci*] [*dlci dlci*] [**input** | **output**]

Example:

```
Router# show policy-map interface serial3/0/0
```

Displays the traffic policy attached to an interface.

Enabling the Control Word

Procedure

	Command or Action	Purpose
Step 1	enable Example: Router> enable	Enables privileged EXEC mode. • Enter your password if prompted.
Step 2	configure terminal Example: Router# configure terminal	Enters global configuration mode.
Step 3	pseudowire-class cw_enable Example: Router(config)# pseudowire-class cw_enable	Enters pseudowire class configuration mode.
Step 4	encapsulation mpls Example: Router(config-pw-class)# encapsulation mpls	Specifies the tunneling encapsulation. • For AToM, the encapsulation type is MPLS.
Step 5	control-word Example: Router(config-pw-class)# control-word	Enables the control word.

	Command or Action	Purpose
Step 6	end Example: <pre>Router(config-pw-class)# end</pre>	Exits to privileged EXEC mode.

Enabling the Control Word using the commands associated with the L2VPN Protocol-Based CLIs feature

Procedure

	Command or Action	Purpose
Step 1	enable Example: <pre>Router> enable</pre>	Enables privileged EXEC mode. <ul style="list-style-type: none"> • Enter your password if prompted.
Step 2	configure terminal Example: <pre>Router# configure terminal</pre>	Enters global configuration mode.
Step 3	interface pseudowire <i>number</i> Example: <pre>Router(config)# interface pseudowire 1</pre>	Creates an interface pseudowire with a value that you specify and enters pseudowire configuration mode.
Step 4	encapsulation mpls Example: <pre>Router(config-pw)# encapsulation mpls</pre>	Specifies the tunneling encapsulation. <ul style="list-style-type: none"> • For AToM, the encapsulation type is mpls.
Step 5	control-word include Example: <pre>Router(config-pw)# control-word include</pre>	Enables the control word.
Step 6	neighbor <i>peer-address vcid-value</i> Example: <pre>Router(config-pw)# neighbor 10.0.0.1 123</pre>	Specifies the peer IP address and virtual circuit (VC) ID value of a Layer 2 VPN (L2VPN) pseudowire.
Step 7	end Example:	Exits to privileged EXEC mode.

	Command or Action	Purpose
	<code>Router(config-pw)# end</code>	

Configuring MPLS AToM Remote Ethernet Port Shutdown



Note The Any Transport over MPLS (AToM): Remote Ethernet Port Shutdown feature is automatically enabled by default when an image with the feature supported is loaded on the router.

Procedure

	Command or Action	Purpose
Step 1	enable Example: <code>Router> enable</code>	Enables privileged EXEC mode. <ul style="list-style-type: none"> • Enter your password if prompted.
Step 2	configure terminal Example: <code>Router# configure terminal</code>	Enters global configuration mode.
Step 3	pseudowire-class [<i>pw-class-name</i>] Example: <code>Router(config)# pseudowire-class eompls</code>	Specifies the name of a Layer 2 pseudowire class and enters pseudowire class configuration mode.
Step 4	encapsulation mpls Example: <code>Router(config-pw)# encapsulation mpls</code>	Specifies that MPLS is used as the data encapsulation method for tunneling Layer 2 traffic over the pseudowire.
Step 5	exit Example: <code>Router(config-pw)# exit</code>	Exits to global configuration mode.
Step 6	interface <i>type slot / subslot / port</i> <i>[.subinterface]</i> Example: <code>Router (config)# interface GigabitEthernet1/0/0</code>	Configures an interface type and enters interface configuration mode.

	Command or Action	Purpose
Step 7	interface <i>type slot / subslot / port</i> Example: Router (config)# interface GigabitEthernet1/0/0	Configures an interface type and enters interface configuration mode.
Step 8	service instance <i>number ethernet number</i> Example: Router (config-if)# service instance 393 ethernet	Configures an ethernet service instance on an interface and enters service instance configuration mode.
Step 9	encapsulation <i>default</i> Example: Router (config-if-srv)# encapsulation default	Specifies the encapsulation type for the interface, such as dot1q. Note Remote ethernet port shutdown is supported only with encapsulation default.
Step 10	xconnect <i>peer-ip-address vc-id pw-class pw-class-name</i> Example: Router (config-if)# xconnect 10.1.1.1 1 pw-class eompls	Binds an attachment circuit to a pseudowire, and configures an Any Transport over MPLS (AToM) static pseudowire.
Step 11	no remote link failure notification Example: Router (config-if-xconn)# remote link failure notification	Disables MPLS AToM remote link failure notification and shutdown.
Step 12	remote link failure notification Example: Router (config-if-xconn)# remote link failure notification	Enables MPLS AToM remote link failure notification and shutdown.
Step 13	end Example: Router (config-if-xconn)# end	Exits to privileged EXEC mode.

Configuring MPLS AToM Remote Ethernet Port Shutdown using the commands associated with the L2VPN Protocol-Based CLIs feature



Note The Any Transport over MPLS (AToM): Remote Ethernet Port Shutdown feature is automatically enabled by default when an image with the feature supported is loaded on the router.

Procedure

	Command or Action	Purpose
Step 1	enable Example: Device> enable	Enables privileged EXEC mode. <ul style="list-style-type: none"> • Enter your password if prompted.
Step 2	configure terminal Example: Device# configure terminal	Enters global configuration mode.
Step 3	template type pseudowire [<i>pseudowire-name</i>] Example: Device(config)# template type pseudowire eompls	Specifies the name of a Layer 2 pseudowire class and enters pseudowire class configuration mode.
Step 4	encapsulation mpls Example: Device(config-pw)# encapsulation mpls	Specifies that MPLS is used as the data encapsulation method for tunneling Layer 2 traffic over the pseudowire.
Step 5	exit Example: Device(config-pw)# exit	Exits to global configuration mode.
Step 6	interface <i>type slot / subslot / port</i> Example: Device(config)# interface GigabitEthernet1/0/0	Configures an interface type and enters interface configuration mode.
Step 7	interface pseudowire <i>number</i> Example: Device(config-if)# interface pseudowire 100	Specifies the pseudowire interface.

	Command or Action	Purpose
Step 8	source template type pseudowire Example: Device(config-if)# source template type pseudowire eompls	Configures the source template of type pseudowire named eompls.
Step 9	neighbor peer-address vcid-value Example: Device(config-if)# neighbor 10.1.1.1 1	Specifies the peer IP address and virtual circuit (VC) ID value of a Layer 2 VPN (L2VPN) pseudowire.
Step 10	end Example: Device(config-if)# end	Exits to privileged EXEC mode.
Step 11	l2vpn xconnect context context-name Example: Device(config)# l2vpn xconnect context con1	Creates a Layer 2 VPN (L2VPN) cross connect context and enters xconnect configuration mode.
Step 12	no remote link failure notification Example: Device(config-xconnect)# no remote link failure notification	Disables MPLS AToM remote link failure notification and shutdown.
Step 13	remote link failure notification Example: Device(config-xconnect)# remote link failure notification	Enables MPLS AToM remote link failure notification and shutdown.
Step 14	end Example: Device(config-xconnect)# end	Exits to privileged EXEC mode.

Configuration Examples for Any Transport over MPLS

Example: ATM over MPLS

The table below shows the configuration of ATM over MPLS on two PE routers.

Table 7: ATM over MPLS Configuration Example

PE1	PE2
<pre> mpls label protocol ldp mpls ldp router-id Loopback0 force ! interface Loopback0 ip address 10.16.12.12 255.255.255.255 ! interface ATM4/0/0 pvc 0/100 l2transport encapsulation aal0 xconnect 10.13.13.13 100 encapsulation mpls ! interface ATM4/0/0.300 point-to-point no ip directed-broadcast no atm enable-ilmi-trap pvc 0/300 l2transport encapsulation aal0 xconnect 10.13.13.13 300 encapsulation mpls </pre>	<pre> mpls label protocol ldp mpls ldp router-id Loopback0 force ! interface Loopback0 ip address 10.13.13.13 255.255.255.255 ! interface ATM4/0/0 pvc 0/100 l2transport encapsulation aal0 xconnect 10.16.12.12 100 encapsulation mpls ! interface ATM4/0/0.300 point-to-point no ip directed-broadcast no atm enable-ilmi-trap pvc 0/300 l2transport encapsulation aal0 xconnect 10.16.12.12 300 encapsulation mpls </pre>

Example: ATM over MPLS Using Commands Associated with L2VPN Protocol-Based Feature

The table below shows the configuration of ATM over MPLS on two PE routers.

Table 8: ATM over MPLS Configuration Example

PE1	PE2
-----	-----

PE1	PE2
<pre> mpls label protocol ldp mpls ldp router-id Loopback0 force ! interface Loopback0 ip address 10.16.12.12 255.255.255.255 ! interface ATM4/0/0 pvc 0/100 l2transport encapsulation aal0 interface pseudowire 100 encapsulation mpls neighbor 10.0.0.1 123 ! l2vpn xconnect context A member pseudowire 100 member atm 100 ! interface ATM4/0/0.300 point-to-point no atm enable-ilmi-trap pvc 0/300 l2transport encapsulation aal0 interface pseudowire 300 encapsulation mpls neighbor 10.0.0.1 123 </pre>	<pre> mpls label protocol ldp mpls ldp router-id Loopback0 force ! interface Loopback0 ip address 10.13.13.13 255.255.255.255 ! interface ATM4/0/0 pvc 0/100 l2transport encapsulation aal0 interface pseudowire 100 encapsulation mpls neighbor 10.0.0.1 123 ! l2vpn xconnect context A member pseudowire 100 member atm 100 ! interface ATM4/0/0.300 point-to-point no ip directed-broadcast no atm enable-ilmi-trap pvc 0/300 l2transport encapsulation aal0 interface pseudowire 300 encapsulation mpls </pre>

PE1	PE2
<pre>! l2vpn xconnect context A member pseudowire 300 member atm 300</pre>	<pre>neighbor 10.0.0.1 123 ! l2vpn xconnect context A member pseudowire 300 member atm 300</pre>

Example: Configuring ATM AAL5 over MPLS in VC Class Configuration Mode

The following example configures ATM AAL5 over MPLS in VC class configuration mode. The VC class is then applied to an interface.

```
enable
configure terminal
vc-class atm aal5class
encapsulation aal5
interface atm1/0/0
class-int aal5class
pvc 1/200 l2transport
xconnect 10.13.13.13 100 encapsulation mpls
```

The following example configures ATM AAL5 over MPLS in VC class configuration mode. The VC class is then applied to a PVC.

```
enable
configure terminal
vc-class atm aal5class
encapsulation aal5
interface atm1/0/0
pvc 1/200 l2transport
class-vc aal5class
xconnect 10.13.13.13 100 encapsulation mpls
```

Example: Configuring ATM AAL5 over MPLS in VC Class Configuration Mode Using Commands Associated with L2VPN Protocol-Based Feature

The following example configures ATM AAL5 over MPLS in VC class configuration mode. The VC class is then applied to an interface.

```
enable
configure terminal
vc-class atm aal5class
encapsulation aal5
interface atm1/0/0
class-int aal5class
pvc 1/200 l2transport
interface pseudowire 100
encapsulation mpls
```



```

neighbor 10.0.0.1 123
exit
l2vpn xconnect context A
member pseudowire 100
member atm 100
exit

```

Example: Ethernet over MPLS with MPLS Traffic Engineering Fast Reroute

The following configuration example and the figure show the configuration of Ethernet over MPLS with fast reroute on AToM PE routers.

Routers PE1 and PE2 have the following characteristics:

- A TE tunnel called Tunnel41 is configured between PE1 and PE2, using an explicit path through a link called L1. AToM VCs are configured to travel through the FRR-protected tunnel Tunnel41.
- The link L1 is protected by FRR, the backup tunnel is Tunnel1.
- PE2 is configured to forward the AToM traffic back to PE1 through the L2 link.

Figure 3: Fast Reroute Configuration

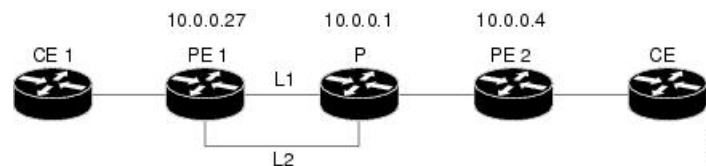

PE1 Configuration

```

mpls label protocol ldp
mpls traffic-eng tunnels
mpls ldp router-id Loopback1 force
!
pseudowire-class T41
  encapsulation mpls
  preferred-path interface Tunnel41 disable-fallback
!
pseudowire-class IP1
  encapsulation mpls
  preferred-path peer 10.4.0.1 disable-fallback
!
interface Loopback1
  ip address 10.0.0.27 255.255.255.255
!
interface Tunnel1
  ip unnumbered Loopback1
  tunnel destination 10.0.0.1
  tunnel mode mpls traffic-eng
  tunnel mpls traffic-eng priority 1 1
  tunnel mpls traffic-eng bandwidth 10000
  tunnel mpls traffic-eng path-option 1 explicit name FRR
!
interface Tunnel41
  ip unnumbered Loopback1
  tunnel destination 10.0.0.4
  tunnel mode mpls traffic-eng
  tunnel mpls traffic-eng priority 1 1
  tunnel mpls traffic-eng bandwidth 1000

```

```

tunnel mpls traffic-eng path-option 1 explicit name name-1
tunnel mpls traffic-eng fast-reroute
!
interface POS0/0/0
description pelname POS8/0/0
ip address 10.1.0.2 255.255.255.252
mpls traffic-eng tunnels
mpls traffic-eng backup-path Tunnel1
crc 16
clock source internal
pos ais-shut
pos report lrldi
ip rsvp bandwidth 155000 155000
!
interface POS0/3/0
description pelname POS10/1/0
ip address 10.1.0.14 255.255.255.252
mpls traffic-eng tunnels
crc 16
clock source internal
ip rsvp bandwidth 155000 155000
!
interface gigabitethernet3/0/0.1
encapsulation dot1Q 203
xconnect 10.0.0.4 2 pw-class IP1
!
interface gigabitethernet3/0/0.2
encapsulation dot1Q 204
xconnect 10.0.0.4 4 pw-class T41
!
router ospf 1
network 10.0.0.0 0.255.255.255 area 0
mpls traffic-eng router-id Loopback1
mpls traffic-eng area 0
!
ip classless
ip route 10.4.0.1 255.255.255.255 Tunnel141
!
ip explicit-path name xxxx-1 enable
next-address 10.4.1.2
next-address 10.1.0.10

```

P Configuration

```

ip cef
mpls traffic-eng tunnels
!
interface Loopback1
ip address 10.0.0.1 255.255.255.255
!
interface FastEthernet1/0/0
ip address 10.4.1.2 255.255.255.0
mpls traffic-eng tunnels
ip rsvp bandwidth 10000 10000
!
interface POS8/0/0
description xxxx POS0/0
ip address 10.1.0.1 255.255.255.252
mpls traffic-eng tunnels
pos ais-shut
pos report lrldi
ip rsvp bandwidth 155000 155000
!

```

```

interface POS10/1/0
  description xxxx POS0/3
  ip address 10.1.0.13 255.255.255.252
  mpls traffic-eng tunnels
  ip rsvp bandwidth 155000 155000
!
router ospf 1
  network 10.0.0.0 0.255.255.255 area 0
  mpls traffic-eng router-id Loopback1
  mpls traffic-eng area 0

```

PE2 Configuration

```

ip cef
mpls label protocol ldp
mpls traffic-eng tunnels
mpls ldp router-id Loopback1 force
!
interface Loopback1
  ip address 10.0.0.4 255.255.255.255
!
interface loopback 2
  ip address 10.4.0.1 255.255.255.255
!
interface Tunnel27
  ip unnumbered Loopback1
  tunnel destination 10.0.0.27
  tunnel mode mpls traffic-eng
  tunnel mpls traffic-eng autoroute announce
  tunnel mpls traffic-eng priority 1 1
  tunnel mpls traffic-eng bandwidth 1000
  tunnel mpls traffic-eng path-option 1 explicit name xxxx-1
!
interface FastEthernet0/0/0.2
  encapsulation dot1Q 203
  xconnect 10.0.0.27 2 encapsulation mpls
!
interface FastEthernet0/0/0.3
  encapsulation dot1Q 204
  xconnect 10.0.0.27 4 encapsulation mpls
!
interface FastEthernet1/1/0
  ip address 10.4.1.1 255.255.255.0
  mpls traffic-eng tunnels
  ip rsvp bandwidth 10000 10000
!
router ospf 1
  network 10.0.0.0 0.255.255.255 area 0
  mpls traffic-eng router-id Loopback1
  mpls traffic-eng area 0
!
ip explicit-path name xxxx-1 enable
  next-address 10.4.1.2
  next-address 10.1.0.10

```

Example: Ethernet over MPLS with MPLS Traffic Engineering Fast Reroute Using Commands Associated with L2VPN Protocol-Based Feature

The following configuration example and the figure show the configuration of Ethernet over MPLS with fast reroute on AToM PE routers.

Routers PE1 and PE2 have the following characteristics:

- A TE tunnel called Tunnel41 is configured between PE1 and PE2, using an explicit path through a link called L1. AToM VCs are configured to travel through the FRR-protected tunnel Tunnel1.
- The link L1 is protected by FRR, the backup tunnel is Tunnel1.
- PE2 is configured to forward the AToM traffic back to PE1 through the L2 link.

Figure 4: Fast Reroute Configuration

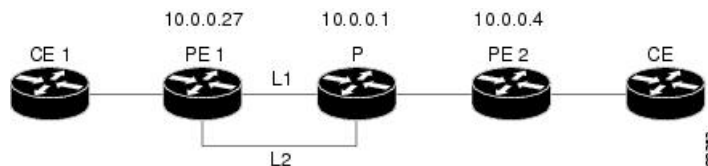

PE1 Configuration

```

mpls label protocol ldp
mpls traffic-eng tunnels
mpls ldp router-id Loopback1 force
!
template type pseudowire T41
  encapsulation mpls
  preferred-path interface Tunnel41 disable-fallback
!
template type pseudowire IP1
  encapsulation mpls
  preferred-path peer 10.4.0.1 disable-fallback
!
interface Loopback1
  ip address 10.0.0.27 255.255.255.255
!
interface Tunnel1
  ip unnumbered Loopback1
  tunnel destination 10.0.0.1
  tunnel mode mpls traffic-eng
  tunnel mpls traffic-eng priority 1 1
  tunnel mpls traffic-eng bandwidth 10000
  tunnel mpls traffic-eng path-option 1 explicit name FRR
!
interface Tunnel41
  ip unnumbered Loopback1
  tunnel destination 10.0.0.4
  tunnel mode mpls traffic-eng
  tunnel mpls traffic-eng priority 1 1
  tunnel mpls traffic-eng bandwidth 1000
  tunnel mpls traffic-eng path-option 1 explicit name name-1
  tunnel mpls traffic-eng fast-reroute
!
interface POS0/0/0
  description pelname POS8/0/0
  ip address 10.1.0.2 255.255.255.252
  mpls traffic-eng tunnels
  mpls traffic-eng backup-path Tunnel1
  crc 16
  clock source internal
  pos ais-shut
  pos report lrdi
  ip rsvp bandwidth 155000 155000

```

```

!
interface POS0/3/0
  description pelname POS10/1/0
  ip address 10.1.0.14 255.255.255.252
  mpls traffic-eng tunnels
  crc 16
  clock source internal
  ip rsvp bandwidth 155000 155000
!
interface gigabitethernet3/0/0.1
  encapsulation dot1Q 203
  interface pseudowire 100
  source template type pseudowire T41
  neighbor 10.0.0.4 2
!
l2vpn xconnect context con1
!
interface gigabitethernet3/0/0.2
  encapsulation dot1Q 204
  interface pseudowire 100
  source template type pseudowire IP1
  neighbor 10.0.0.4 4
!
l2vpn xconnect context con2
!
router ospf 1
  network 10.0.0.0 0.255.255.255 area 0
  mpls traffic-eng router-id Loopback1
  mpls traffic-eng area 0
!
ip classless
ip route 10.4.0.1 255.255.255.255 Tunnel41
!
ip explicit-path name xxxx-1 enable
  next-address 10.4.1.2
  next-address 10.1.0.10

```

P Configuration

```

ip cef
mpls traffic-eng tunnels
!
interface Loopback1
  ip address 10.0.0.1 255.255.255.255
!
interface FastEthernet1/0/0
  ip address 10.4.1.2 255.255.255.0
  mpls traffic-eng tunnels
  ip rsvp bandwidth 10000 10000
!
interface POS8/0/0
  description xxxx POS0/0
  ip address 10.1.0.1 255.255.255.252
  mpls traffic-eng tunnels
  pos ais-shut
  pos report lrldi
  ip rsvp bandwidth 155000 155000
!
interface POS10/1/0
  description xxxx POS0/3
  ip address 10.1.0.13 255.255.255.252
  mpls traffic-eng tunnels
  ip rsvp bandwidth 155000 155000

```

```

!
router ospf 1
 network 10.0.0.0 0.255.255.255 area 0
 mpls traffic-eng router-id Loopback1
 mpls traffic-eng area 0

```

PE2 Configuration

```

ip cef
 mpls label protocol ldp
 mpls traffic-eng tunnels
 mpls ldp router-id Loopback1 force
!
interface Loopback1
 ip address 10.0.0.4 255.255.255.255
!
interface loopback 2
 ip address 10.4.0.1 255.255.255.255
!
interface Tunnel27
 ip unnumbered Loopback1
 tunnel destination 10.0.0.27
 tunnel mode mpls traffic-eng
 tunnel mpls traffic-eng autoroute announce
 tunnel mpls traffic-eng priority 1 1
 tunnel mpls traffic-eng bandwidth 1000
 tunnel mpls traffic-eng path-option 1 explicit name xxxx-1
!
interface FastEthernet0/0/0.2
 encapsulation dot1Q 203
 interface pseudowire 100
 encapsulation mpls
 neighbor 10.0.0.1 123
!
l2vpn xconnect context A
 member pseudowire 100
 member gigabitethernet 0/0/0.1
!
interface FastEthernet0/0/0.3
 encapsulation dot1Q 204
 interface pseudowire 100
 encapsulation mpls
 neighbor 10.0.0.1 123
!
l2vpn xconnect context A
 member pseudowire 100
 member gigabitethernet 0/0/0.1
!
interface FastEthernet1/1/0
 ip address 10.4.1.1 255.255.255.0
 mpls traffic-eng tunnels
 ip rsvp bandwidth 10000 10000
!
router ospf 1
 network 10.0.0.0 0.255.255.255 area 0
 mpls traffic-eng router-id Loopback1
 mpls traffic-eng area 0
!
ip explicit-path name xxxx-1 enable
 next-address 10.4.1.2
 next-address 10.1.0.10

```

Example: Configuring Tunnel Selection

The following example shows how to set up two preferred paths for PE1. One preferred path specifies an MPLS traffic engineering tunnel. The other preferred path specifies an IP address of a loopback address on PE2. There is a static route configured on PE1 that uses a TE tunnel to reach the IP address on PE2.

PE1 Configuration

```

mpls label protocol ldp
mpls traffic-eng tunnels
tag-switching tdp router-id Loopback0
pseudowire-class pw1
  encapsulation mpls
  preferred-path interface Tunnel1 disable-fallback
!
pseudowire-class pw2
  encapsulation mpls
  preferred-path peer 10.18.18.18
!
interface Loopback0
  ip address 10.2.2.2 255.255.255.255
  no ip directed-broadcast
  no ip mroute-cache
!
interface Tunnel1
  ip unnumbered Loopback0
  no ip directed-broadcast
  tunnel destination 10.16.16.16
  tunnel mode mpls traffic-eng
  tunnel mpls traffic-eng priority 7 7
  tunnel mpls traffic-eng bandwidth 1500
  tunnel mpls traffic-eng path-option 1 explicit name path-tu1
!
interface Tunnel2
  ip unnumbered Loopback0
  no ip directed-broadcast
  tunnel destination 10.16.16.16
  tunnel mode mpls traffic-eng
  tunnel mpls traffic-eng priority 7 7
  tunnel mpls traffic-eng bandwidth 1500
  tunnel mpls traffic-eng path-option 1 dynamic
!
interface gigabitethernet0/0/0
  no ip address
  no ip directed-broadcast
  no negotiation auto
!
interface gigabitethernet0/0/0.1
  encapsulation dot1Q 222
  no ip directed-broadcast
  xconnect 10.16.16.16 101 pw-class pw1
!
interface ATM1/0/0
  no ip address
  no ip directed-broadcast
  no atm enable-ilmi-trap
  no atm ilmi-keepalive
  pvc 0/50 l2transport
  encapsulation aal5
  xconnect 10.16.16.16 150 pw-class pw2
!

```

```

interface FastEthernet2/0/1
 ip address 10.0.0.1 255.255.255.0
 no ip directed-broadcast
 tag-switching ip
 mpls traffic-eng tunnels
 ip rsvp bandwidth 15000 15000
 !
router ospf 1
 log-adjacency-changes
 network 10.0.0.0 0.0.0.255 area 0
 network 10.2.2.2 0.0.0.0 area 0
 mpls traffic-eng router-id Loopback0
 mpls traffic-eng area 0
 !
ip route 10.18.18.18 255.255.255.255 Tunnel2
 !
ip explicit-path name path-tul enable
 next-address 10.0.0.1
 index 3 next-address 10.0.0.1

```

PE2 Configuration

```

mpls label protocol ldp
 mpls traffic-eng tunnels
 mpls ldp router-id Loopback0
interface Loopback0
 ip address 10.16.16.16 255.255.255.255
 no ip directed-broadcast
 no ip mroute-cache
 !
interface Loopback2
 ip address 10.18.18.18 255.255.255.255
 no ip directed-broadcast
 !
interface FastEthernet1/1/0
 ip address 10.0.0.2 255.255.255.0
 no ip directed-broadcast
 mpls traffic-eng tunnels
 mpls ip
 no cdp enable
 ip rsvp bandwidth 15000 15000
 !
interface FastEthernet1/1/1
 no ip address
 no ip directed-broadcast
 no cdp enable
 !
interface FastEthernet1/1/1.1
 encapsulation dot1Q 222
 no ip directed-broadcast
 no cdp enable
 mpls l2transport route 10.2.2.2 101
 !
interface ATM5/0/0
 no ip address
 no ip directed-broadcast
 no atm enable-ilmi-trap
 no atm ilmi-keepalive
 pvc 0/50 l2transport
 encapsulation aal5
 xconnect 10.2.2.2 150 encapsulation mpls
 !
router ospf 1

```



```

log-adjacency-changes
network 10.0.0.0 0.0.0.255 area 0
network 10.16.16.16 0.0.0.0 area 0
mpls traffic-eng router-id Loopback0
mpls traffic-eng area 0

```

Example: Configuring Tunnel Selection Using Commands Associated with L2VPN Protocol-Based Feature

The following example shows how to set up two preferred paths for PE1. One preferred path specifies an MPLS traffic engineering tunnel. The other preferred path specifies an IP address of a loopback address on PE2. There is a static route configured on PE1 that uses a TE tunnel to reach the IP address on PE2.

PE1 Configuration

```

mpls label protocol ldp
mpls traffic-eng tunnels
tag-switching tdp router-id Loopback0
template type pseudowire pw1
  encapsulation mpls
  preferred-path interface Tunnel1 disable-fallback
!
template type pseudowire pw2
  encapsulation mpls
  preferred-path peer 10.18.18.18
!
interface Loopback0
  ip address 10.2.2.2 255.255.255.255
  no ip directed-broadcast
  no ip mroute-cache
!
interface Tunnel1
  ip unnumbered Loopback0
  no ip directed-broadcast
  tunnel destination 10.16.16.16
  tunnel mode mpls traffic-eng
  tunnel mpls traffic-eng priority 7 7
  tunnel mpls traffic-eng bandwidth 1500
  tunnel mpls traffic-eng path-option 1 explicit name path-tul
!
interface Tunnel2
  ip unnumbered Loopback0
  no ip directed-broadcast
  tunnel destination 10.16.16.16
  tunnel mode mpls traffic-eng
  tunnel mpls traffic-eng priority 7 7
  tunnel mpls traffic-eng bandwidth 1500
  tunnel mpls traffic-eng path-option 1 dynamic
!
interface gigabitethernet0/0/0
  no ip address
  no ip directed-broadcast
  no negotiation auto
!
interface gigabitethernet0/0/0.1
  encapsulation dot1Q 222
  no ip directed-broadcast
  interface pseudowire 100
  source template type pseudowire pw1

```

```

    neighbor 10.16.16.16 101
  !
  l2vpn xconnect context con1
  !
  interface ATM1/0/0
    no ip address
    no ip directed-broadcast
    no atm enable-ilmi-trap
    no atm ilmi-keepalive
    pvc 0/50 l2transport
      encapsulation aal5
    interface pseudowire 100
      source template type pseudowire pw2
    neighbor 10.16.16.16 150
  !
  l2vpn xconnect context con1
  !
  interface FastEthernet2/0/1
    ip address 10.0.0.1 255.255.255.0
    no ip directed-broadcast
    tag-switching ip
    mpls traffic-eng tunnels
    ip rsvp bandwidth 15000 15000
  !
  router ospf 1
    log-adjacency-changes
    network 10.0.0.0 0.0.0.255 area 0
    network 10.2.2.2 0.0.0.0 area 0
    mpls traffic-eng router-id Loopback0
    mpls traffic-eng area 0
  !
  ip route 10.18.18.18 255.255.255.255 Tunnel2
  !
  ip explicit-path name path-tul enable
    next-address 10.0.0.1
    index 3 next-address 10.0.0.1

```

PE2 Configuration

```

mpls label protocol ldp
mpls traffic-eng tunnels
mpls ldp router-id Loopback0
interface Loopback0
  ip address 10.16.16.16 255.255.255.255
  no ip directed-broadcast
  no ip mroute-cache
!
interface Loopback2
  ip address 10.18.18.18 255.255.255.255
  no ip directed-broadcast
!
interface FastEthernet1/1/0
  ip address 10.0.0.2 255.255.255.0
  no ip directed-broadcast
  mpls traffic-eng tunnels
  mpls ip
  no cdp enable
  ip rsvp bandwidth 15000 15000
!
interface FastEthernet1/1/1
  no ip address
  no ip directed-broadcast
  no cdp enable

```

```

!
interface FastEthernet1/1/1.1
 encapsulation dot1Q 222
 no ip directed-broadcast
 no cdp enable
 mpls l2transport route 10.2.2.2 101
!
interface ATM5/0/0
 no ip address
 no ip directed-broadcast
 no atm enable-ilmi-trap
 no atm ilmi-keepalive
 pvc 0/50 l2transport
 encapsulation aal5
 interface pseudowire 100
 encapsulation mpls
 neighbor 10.2.2.2 150
!
l2vpn xconnect context A
 member pseudowire 100
 member GigabitEthernet0/0/0.1
!
router ospf 1
 log-adjacency-changes
 network 10.0.0.0 0.0.0.255 area 0
 network 10.16.16.16 0.0.0.0 area 0
 mpls traffic-eng router-id Loopback0
 mpls traffic-eng area 0

```

Example: Configuring MTU Values in xconnect Configuration Mode for L2VPN Interworking

The following example shows an L2VPN Interworking example. The PE1 router has a serial interface configured with an MTU value of 1492 bytes. The PE2 router uses xconnect configuration mode to set a matching MTU of 1492 bytes, which allows the two routers to form an interworking VC. If the PE2 router did not set the MTU value in xconnect configuration mode, the interface would be set to 1500 bytes by default and the VC would not come up.



Note L2VPN interworking is not supported on Cisco ASR 900 RSP3 Module.

PE1 Configuration

```

pseudowire-class atom-ipiw
 encapsulation mpls
 interworking ip
!
interface Loopback0
 ip address 10.1.1.151 255.255.255.255
!
interface Serial2/0/0
 mtu 1492
 no ip address
 encapsulation ppp
 no fair-queue
 serial restart-delay 0

```

```

xconnect 10.1.1.152 123 pw-class atom-ipiw
!
interface Serial4/0/0
 ip address 10.151.100.1 255.255.255.252
 encapsulation ppp
 mpls ip
 serial restart-delay 0
!
router ospf 1
 log-adjacency-changes
 network 10.1.1.151 0.0.0.0 area 0
 network 10.151.100.0 0.0.0.3 area 0
!
mpls ldp router-id Loopback0

```

PE2 Configuration

```

pseudowire-class atom-ipiw
 encapsulation mpls
 interworking ip
!
interface Loopback0
 ip address 10.1.1.152 255.255.255.255
!
interface FastEthernet0/0/0
 no ip address
 xconnect 10.1.1.151 123 pw-class atom-ipiw
 mtu 1492
!
interface Serial4/0/0
 ip address 10.100.152.2 255.255.255.252
 encapsulation ppp
 mpls ip
 serial restart-delay 0
!
router ospf 1
 log-adjacency-changes
 network 10.1.1.152 0.0.0.0 area 0
 network 10.100.152.0 0.0.0.3 area 0
!
mpls ldp router-id Loopback0

```

The **show mpls l2transport binding** command shows that the MTU value for the local and remote routers is 1492 bytes.

PE1

```

Router# show mpls l2transport binding
Destination Address: 10.1.1.152, VC ID: 123
  Local Label: 105
    Cbit: 1, VC Type: PPP, GroupID: 0
    MTU: 1492, Interface Desc: n/a
    VCCV: CC Type: CW [1], RA [2]
    CV Type: LSPV [2]
  Remote Label: 205
    Cbit: 1, VC Type: FastEthernet, GroupID: 0
    MTU: 1492, Interface Desc: n/a
    VCCV: CC Type: RA [2]
    CV Type: LSPV [2]
Router# show mpls l2transport vc detail
Local interface: Serial2/0/0 up, line protocol up, PPP up

```

```

MPLS VC type is PPP, interworking type is IP
Destination address: 10.1.1.152, VC ID: 123, VC status: up
  Output interface: Serial4/0/0, imposed label stack {1003 205}
  Preferred path: not configured
  Default path: active
  Next hop: point2point
Create time: 00:25:29, last status change time: 00:24:54
Signaling protocol: LDP, peer 10.1.1.152:0 up
  Targeted Hello: 10.1.1.151(LDP Id) -> 10.1.1.152
  Status TLV support (local/remote)   : enabled/supported
    Label/status state machine        : established, LruRru
    Last local dataplane status rcvd: no fault
    Last local SSS circuit status rcvd: no fault
    Last local SSS circuit status sent: no fault
    Last local LDP TLV status sent: no fault
    Last remote LDP TLV status rcvd: no fault
MPLS VC labels: local 105, remote 205
Group ID: local n/a, remote 0
MTU: local 1492, remote 1492
Remote interface description:
Sequencing: receive disabled, send disabled
VC statistics:
  packet totals: receive 30, send 29
  byte totals:   receive 2946, send 3364
  packet drops: receive 0, send 0

```

PE2

```

Router# show mpls l2transport binding
Destination Address: 10.1.1.151, VC ID: 123
  Local Label: 205
    Cbit: 1, VC Type: FastEthernet, GroupID: 0
    MTU: 1492, Interface Desc: n/a
    VCCV: CC Type: RA [2]
    CV Type: LSPV [2]
  Remote Label: 105
    Cbit: 1, VC Type: FastEthernet, GroupID: 0
    MTU: 1492, Interface Desc: n/a
    VCCV: CC Type: CW [1], RA [2]
    CV Type: LSPV [2]
Router# show mpls l2transport vc detail
Local interface: Fe0/0/0 up, line protocol up, FastEthernet up
MPLS VC type is FastEthernet, interworking type is IP
Destination address: 10.1.1.151, VC ID: 123, VC status: up
  Output interface: Se4/0/0, imposed label stack {1002 105}
  Preferred path: not configured
  Default path: active
  Next hop: point2point
Create time: 00:25:19, last status change time: 00:25:19
Signaling protocol: LDP, peer 10.1.1.151:0 up
  Targeted Hello: 10.1.1.152(LDP Id) -> 10.1.1.151
  Status TLV support (local/remote)   : enabled/supported
    Label/status state machine        : established, LruRru
    Last local dataplane status rcvd: no fault
    Last local SSS circuit status rcvd: no fault
    Last local SSS circuit status sent: no fault
    Last local LDP TLV status sent: no fault
    Last remote LDP TLV status rcvd: no fault
MPLS VC labels: local 205, remote 105
Group ID: local n/a, remote 0
MTU: local 1492, remote 1492
Remote interface description:
Sequencing: receive disabled, send disabled

```

```

VC statistics:
  packet totals: receive 29, send 30
  byte totals:   receive 2900, send 3426
  packet drops:  receive 0, send 0

```

Example: Configuring MTU Values in xconnect Configuration Mode for L2VPN Interworking Using Commands Associated with L2VPN Protocol-Based Feature

The following example shows an L2VPN Interworking example. The PE1 router has a serial interface configured with an MTU value of 1492 bytes. The PE2 router uses xconnect configuration mode to set a matching MTU of 1492 bytes, which allows the two routers to form an interworking VC. If the PE2 router did not set the MTU value in xconnect configuration mode, the interface would be set to 1500 bytes by default and the VC would not come up.

PE1 Configuration

```

template type pseudowire atom-ipiw
  encapsulation mpls
  interworking ip
!
interface Loopback0
  ip address 10.1.1.151 255.255.255.255
!
interface Serial2/0/0
  mtu 1492
  no ip address
  encapsulation ppp
  no fair-queue
  serial restart-delay 0
interface pseudowire 100
  source template type pseudowire atom-ipiw
  neighbor 10.1.1.152 123
!
l2vpn xconnect context con1
  member <ac_int>
  member pseudowire 100
!
interface Serial4/0/0
  ip address 10.151.100.1 255.255.255.252
  encapsulation ppp
  mpls ip
  serial restart-delay 0
!
router ospf 1
  log-adjacency-changes
  network 10.1.1.151 0.0.0.0 area 0
  network 10.151.100.0 0.0.0.3 area 0
!
mpls ldp router-id Loopback0

```

PE2 Configuration

```

template type pseudowire atom-ipiw
  encapsulation mpls
  interworking ip
!
interface Loopback0
  ip address 10.1.1.152 255.255.255.255

```

```

!
interface FastEthernet0/0/0
  no ip address
  interface pseudowire 100
    source template type pseudowire atom-ipiw
    neighbor 10.1.1.151 123
!
l2vpn xconnect context con1
  member <ac_int>
  member pseudowire1
!
interface Serial4/0/0
  ip address 10.100.152.2 255.255.255.252
  encapsulation ppp
  mpls ip
  serial restart-delay 0
!
router ospf 1
  log-adjacency-changes
  network 10.1.1.152 0.0.0.0 area 0
  network 10.100.152.0 0.0.0.3 area 0
!
mpls ldp router-id Loopback0

```

The **show l2vpn atom binding** command shows that the MTU value for the local and remote routers is 1492 bytes.

PE1

```

Device# show l2vpn atom binding
Destination Address: 10.1.1.152, VC ID: 123
  Local Label: 105
    Cbit: 1, VC Type: PPP, GroupID: 0
    MTU: 1492, Interface Desc: n/a
    VCCV: CC Type: CW [1], RA [2]
          CV Type: LSPV [2]
  Remote Label: 205
    Cbit: 1, VC Type: FastEthernet, GroupID: 0
    MTU: 1492, Interface Desc: n/a
    VCCV: CC Type: RA [2]
          CV Type: LSPV [2]
Device# show l2vpn atom vc detail
Local interface: Serial2/0/0 up, line protocol up, PPP up
MPLS VC type is PPP, interworking type is IP
Destination address: 10.1.1.152, VC ID: 123, VC status: up
Output interface: Serial4/0/0, imposed label stack {1003 205}
Preferred path: not configured
Default path: active
Next hop: point2point
Create time: 00:25:29, last status change time: 00:24:54
Signaling protocol: LDP, peer 10.1.1.152:0 up
Targeted Hello: 10.1.1.151(LDP Id) -> 10.1.1.152
Status TLV support (local/remote) : enabled/supported
Label/status state machine : established, LruRru
Last local dataplane status rcvd: no fault
Last local SSS circuit status rcvd: no fault
Last local SSS circuit status sent: no fault
Last local LDP TLV status sent: no fault
Last remote LDP TLV status rcvd: no fault
MPLS VC labels: local 105, remote 205
Group ID: local n/a, remote 0
MTU: local 1492, remote 1492
Remote interface description:

```

```

Sequencing: receive disabled, send disabled
VC statistics:
  packet totals: receive 30, send 29
  byte totals:   receive 2946, send 3364
  packet drops:  receive 0, send 0

```

PE2

```

Device# show l2vpn atom binding
Destination Address: 10.1.1.151, VC ID: 123
  Local Label: 205
    Cbit: 1, VC Type: FastEthernet, GroupID: 0
    MTU: 1492, Interface Desc: n/a
    VCCV: CC Type: RA [2]
          CV Type: LSPV [2]
  Remote Label: 105
    Cbit: 1, VC Type: FastEthernet, GroupID: 0
    MTU: 1492, Interface Desc: n/a
    VCCV: CC Type: CW [1], RA [2]
          CV Type: LSPV [2]
Device# show l2vpn atom vc detail
Local interface: Fe0/0/0 up, line protocol up, FastEthernet up
MPLS VC type is FastEthernet, interworking type is IP
Destination address: 10.1.1.151, VC ID: 123, VC status: up
Output interface: Se4/0/0, imposed label stack {1002 105}
Preferred path: not configured
Default path: active
Next hop: point2point
Create time: 00:25:19, last status change time: 00:25:19
Signaling protocol: LDP, peer 10.1.1.151:0 up
Targeted Hello: 10.1.1.152(LDP Id) -> 10.1.1.151
Status TLV support (local/remote) : enabled/supported
Label/status state machine : established, LruRru
Last local dataplane status rcvd: no fault
Last local SSS circuit status rcvd: no fault
Last local SSS circuit status sent: no fault
Last local LDP TLV status sent: no fault
Last remote LDP TLV status rcvd: no fault
MPLS VC labels: local 205, remote 105
Group ID: local n/a, remote 0
MTU: local 1492, remote 1492
Remote interface description:
Sequencing: receive disabled, send disabled
VC statistics:
  packet totals: receive 29, send 30
  byte totals:   receive 2900, send 3426
  packet drops:  receive 0, send 0

```

Examples: Configuring Any Transport over MPLS (AToM) Remote Ethernet Port Shutdown

The following example shows how to enable remote Ethernet port shutdown:

```

configure terminal
!
pseudowire-class eompls
 encapsulation mpls
!
interface GigabitEthernet1/0/0

```



```
xconnect 10.1.1.1 1 pw-class eompls
remote link failure notification
```

The following example shows how to disable remote Ethernet port shutdown:

```
configure terminal
!
pseudowire-class eompls
encapsulation mpls
!
interface GigabitEthernet1/0/0
xconnect 10.1.1.1 1 pw-class eompls
no remote link failure notification
```

The related **show** command output reports operational status for all remote L2 Tunnels by interface.

```
Router# show interface G1/0/0
GigabitEthernet1/0/0 is L2 Tunnel remote down, line protocol is up
Hardware is GigMac 4 Port GigabitEthernet, address is 0003.ff4e.12a8 (bia 0003.ff4e.12a8)
Internet address is 10.9.9.2/16
MTU 1500 bytes, BW 1000000 Kbit, DLY 10 usec, rely 255/255, load 1/255
Router# show ip interface brief
Interface          IP-Address      OK? Method Status Protocol
GigabitEthernet2/0/0 unassigned      YES NVRAM   L2 Tunnel remote down up
GigabitEthernet2/1/0 unassigned      YES NVRAM   administratively down down
```



Note Remote Ethernet port shutdown is enabled by default when EVC "default encapsulation" is configured.

Examples: Configuring Any Transport over MPLS (AToM) Remote Ethernet Port Shutdown Using Commands Associated with L2VPN Protocol-Based Feature

The following example shows how to enable remote Ethernet port shutdown:

```
configure terminal
!
template type pseudowire eompls
encapsulation mpls
!
interface GigabitEthernet1/0/0
interface pseudowire 100
source template type pseudowire eompls
neighbor 10.1.1.1 1
!
l2vpn xconnect context con1
remote link failure notification
```

The following example shows how to disable remote Ethernet port shutdown:

```
configure terminal
!
template type pseudowire eompls
encapsulation mpls
!
interface GigabitEthernet1/0/0
interface pseudowire 100
source template type pseudowire eompls
```

```

neighbor 10.1.1.1 1
!
l2vpn xconnect context con1
no remote link failure notification

```

The related **show** command output reports operational status for all remote L2 Tunnels by interface.

```

Router# show interface G1/0/0
GigabitEthernet1/0/0 is L2 Tunnel remote down, line protocol is up
Hardware is GigMac 4 Port GigabitEthernet, address is 0003.ff4e.12a8 (bia 0003.ff4e.12a8)
Internet address is 10.9.9.2/16
MTU 1500 bytes, BW 1000000 Kbit, DLY 10 usec, rely 255/255, load 1/255
Router# show ip interface brief
Interface          IP-Address      OK? Method Status Protocol
GigabitEthernet2/0/0 unassigned      YES NVRAM   L2 Tunnel remote down up
GigabitEthernet2/1/0 unassigned      YES NVRAM   administratively down down

```

Additional References for Any Transport over MPLS

Related Documents

Related Topic	Document Title
Cisco IOS commands	Cisco IOS Master Command List, All Releases
MPLS commands	Cisco IOS Multiprotocol Label Switching Command Reference

Technical Assistance

Description	Link
The Cisco Support and Documentation website provides online resources to download documentation, software, and tools. Use these resources to install and configure the software and to troubleshoot and resolve technical issues with Cisco products and technologies. Access to most tools on the Cisco Support and Documentation website requires a Cisco.com user ID and password.	http://www.cisco.com/cisco/web/support/index.html

Feature Information for Any Transport over MPLS

The following table provides release information about the feature or features described in this module. This table lists only the software release that introduced support for a given feature in a given software release train. Unless noted otherwise, subsequent releases of that software release train also support that feature.

Use Cisco Feature Navigator to find information about platform support and Cisco software image support. To access Cisco Feature Navigator, go to www.cisco.com/go/cfn. An account on Cisco.com is not required.

Table 9: Feature Information for Any Transport over MPLS

Feature Name	Releases	Feature Information
Any Transport over MPLS	Cisco IOS XE Release 3.13.0S	This feature was introduced on the Cisco ASR 920 Routers (ASR-920-12CZ-A, ASR-920-12CZ-D, ASR-920-4SZ-A, ASR-920-4SZ-D).



CHAPTER 4

Loop-Free Alternate Fast Reroute

Loop-Free Alternate (LFA) Fast Reroute (FRR) is a mechanism that provides local protection for unicast traffic in order to rapidly converge traffic flows around link and/or node failures.

- [Prerequisites for Loop-Free Alternate Fast Reroute, on page 89](#)
- [Restrictions for Loop-Free Alternate Fast Reroute, on page 89](#)
- [Information About Loop-Free Alternate Fast Reroute, on page 90](#)
- [Remote LFA for MLDP, on page 93](#)
- [How to Configure Loop-Free Alternate Fast Reroute, on page 94](#)
- [Configuring Remote LFA FRR for MLDP, on page 98](#)
- [Verifying Loop-Free Alternate Fast Reroute, on page 105](#)
- [Verifying Remote Loop-Free Alternate Fast Reroute with VPLS, on page 109](#)
- [Verifying Tunnel Interfaces Created by OSPF IPv4 Remote LFA IPFRR, on page 111](#)
- [Additional References, on page 112](#)

Prerequisites for Loop-Free Alternate Fast Reroute

- Any of the following protocols must be supported for Loop-Free Alternate Fast Reroute:
 - Intermediate System-to-Intermediate System (IS-IS)
 - Open Shortest Path First (OSPF)
- While configuring ISIS protocol, **isis network point-to-point** must be configured.

Restrictions for Loop-Free Alternate Fast Reroute

- Logical interfaces namely Port-channel (PoCH) support LFA FRR and remote LFA-FRR, with a single member link. Port-channel can be used as a backup path.
- Micro loops may form due to traffic congestion.
- A Multiprotocol Label Switching (MPLS) traffic engineering (TE) tunnel cannot be used as a protected interface. However, an MPLS-TE tunnel can be a protecting (repair) interface as long as the TE tunnel is used as a primary path.

- For TDM pseudowires, the interfaces supported are CEM (CESoP, SAToP) and IMA (PVC,PVP); supported both on OC-3 and T1/E1 controllers. A maximum of 500 VCs can be configured per OC-3 controller.
- Each bridge domain interface (BDI) protected by FRR can have only one EFP.
- Remote LFA FRR provides better convergence with SFP ports rather than copper ports. As a workaround for copper ports, BFD triggered FRR can be used.
- FRR is *not* supported with POS and serial interfaces.
- Scale limit for FRR-protected global prefixes is 1500 and for layer 3 VPNs, scale limit is 4000.

Information About Loop-Free Alternate Fast Reroute

The Loop-Free Alternate (LFA) Fast Reroute (FRR) feature offers an alternative to the MPLS Traffic Engineering Fast Reroute feature to minimize packet loss due to link or node failure.

LFA FRR enables a backup route to avoid traffic loss if a network fails. The backup routes (repair paths) are precomputed and installed in the router as the backup for the primary paths. After the router detects a link or adjacent node failure, it switches to the backup path to avoid traffic loss.

LFA is a node other than the primary neighbor. Traffic is redirected to an LFA after a network failure. An LFA makes the forwarding decision without any knowledge of the failure. An LFA must neither use a failed element nor use a protecting node to forward traffic. An LFA must not cause loops. By default, LFA is enabled on all supported interfaces as long as the interface can be used as a primary path.

Advantages of using per-prefix LFAs are as follows:

- The repair path forwards traffic during transition when the primary path link is down.
- All destinations having a per-prefix LFA are protected. This leaves only a subset (a node at the far side of the failure) unprotected.

Supported Information

- LFA FRR is supported with equal cost multipath (ECMP).
- Fast Reroute triggered by Bidirectional Forwarding (BFD) is supported.
- Remote LFA tunnels are High Availability aware; hence, Stateful Switchover (SSO) compliant.

Benefits of Loop-Free Alternate Fast Reroute

- Same level of protection from traffic loss
- Simplified configuration
- Link and node protection
- Link and path protection
- LFA (loop-free alternate) paths

- Support for both IP and Label Distribution Protocol (LDP) core
- LFA FRR is supported with equal cost multipath (ECMP).
- Fast Reroute triggered by Bidirectional Forwarding (BFD).
- Remote LFA tunnels are High Availability aware; hence, Stateful Switchover (SSO) compliant.

LFA FRR and Remote LFA FRR over Bridge Domains Interfaces

The router supports bridge domain interfaces (BDI). For information on configuring bridge domains, see [Configuring Ethernet Virtual Connections on the Cisco ASR 903 Router](#).

LFA FRR and remote LFA FRR is supported on bridge domain interfaces on the router. For information on configuring Remote LFA FRR on BDI, see [How to Configure Loop-Free Alternate Fast Reroute, on page 94](#).

IS-IS and IP FRR

When a local link fails in a network, IS-IS recomputes new primary next-hop routes for all affected prefixes. These prefixes are updated in the RIB and the Forwarding Information Base (FIB). Until the primary prefixes are updated in the forwarding plane, traffic directed towards the affected prefixes are discarded. This process can take hundreds of milliseconds.

In IP FRR, IS-IS computes LFA next-hop routes for the forwarding plane to use in case of primary path failures. LFA is computed per prefix.

When there are multiple LFAs for a given primary path, IS-IS uses a tiebreaking rule to pick a single LFA for a primary path. In case of a primary path with multiple LFA paths, prefixes are distributed equally among LFA paths.

Repair Paths

Repair paths forward traffic during a routing transition. When a link or a router fails, due to the loss of a physical layer signal, initially, only the neighboring routers are aware of the failure. All other routers in the network are unaware of the nature and location of this failure until information about this failure is propagated through a routing protocol, which may take several hundred milliseconds. It is, therefore, necessary to arrange for packets affected by the network failure to be steered to their destinations.

A router adjacent to the failed link employs a set of repair paths for packets that would have used the failed link. These repair paths are used from the time the router detects the failure until the routing transition is complete. By the time the routing transition is complete, all routers in the network revise their forwarding data and the failed link is eliminated from the routing computation.

Repair paths are precomputed in anticipation of failures so that they can be activated the moment a failure is detected.

The IPv4 LFA FRR feature uses the following repair paths:

- Equal Cost Multipath (ECMP) uses a link as a member of an equal cost path-split set for a destination. The other members of the set can provide an alternative path when the link fails.
- LFA is a next-hop route that delivers a packet to its destination without looping back. Downstream paths are a subset of LFAs.

Remote LFA FRR

Some topologies (for example the commonly used ring-based topology) require protection that is not afforded by LFA FRR alone. Consider the topology shown in the figure below:

Figure 5: Remote LFA FRR with Ring Topology

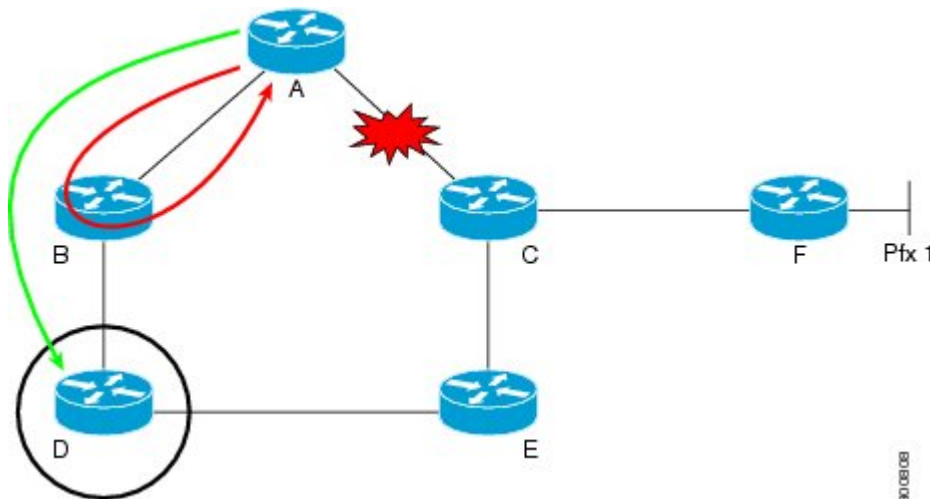

The red looping arrow represents traffic that is looping immediately after a failure between node A and C (before network reconvergence). Device A tries to send traffic destined to F to next-hop B. Device B cannot be used as an LFA for prefixes advertised by nodes C and F. The actual LFA is node D. However, node D is not directly connected to the protecting node A. To protect prefixes advertised by C, node A must tunnel the packet around the failed link A-C to node D, provided that the tunnel does not traverse the failing link.

Remote LFA FRR enables you to tunnel a packet around a failed link to a remote loop-free alternate that is more than one hop away. In the figure above, the green arrow between A and D shows the tunnel that is automatically created by the remote LFA feature to bypass looping.

Remote LFA FRR for TDM and ATM Pseudowires

The Router supports two pseudewire types that utilize CEM transport: Structure-Agnostic TDM over Packet (SAToP) and Circuit Emulation Service over Packet-Switched Network (CESoPSN).

Border Gateway Protocol (BGP) Prefix-Independent Convergence (PIC) and LFA FRR Integration

Both the Labeled Border Gateway Protocol (BGP) Prefix-Independent Convergence (PIC) feature and the Loop-Free Alternate (LFA) Fast Reroute (FRR) feature can be configured together on the router.

BGP PIC is supported for bridge domain interfaces (BDI) with FRR.



Note Each bridge domain interface (BDI) protected by FRR can have only one EFP.

For information on configuring BGP PIC, see [BGP PIC Edge for IP and MPLS-VPN](#).

Remote LFA FRR with VPLS

VPLS (Virtual Private LAN Service) enables enterprises to link together their Ethernet-based LANs from multiple sites via the infrastructure provided by their service provider. For information on configuring VPLS, see [Configuring Virtual Private LAN Services](#). Starting With Cisco IOS XE Release 3.10S, Remote LFA FRR is supported with VPLS.

For information on configuring remote LFA FRR with VPLS, see [How to Configure Loop-Free Alternate Fast Reroute, on page 94](#).

Remote LFA for MLDP

Table 10: Feature History Table

Feature Name	Release Information	Description
Remote LFA for MLDP	Cisco IOS XE Bengaluru 17.6.1	Remote Loop-Free Alternate (RLFA) based Fast Reroute (FRR) improves LFA coverage. When used with Multicast Label Distribution Protocol (MLDP) for IPv4, there's no need for an extra protocol in the control plane.

Loop-Free Alternate (LFA) FRR mechanism enables a backup route to avoid traffic loss if a network fails. The backup routes are precomputed and installed in the router as backup for primary paths. After the Cisco router detects a link or adjacent node failure, it switches to the backup path to avoid traffic loss. As the backup paths are pre-calculated and installed, switching to back up path is fast, in case of failure.

Effective Cisco IOS XE Bengaluru 17.6.1, you can enable this feature to effectively use backup routes to help with load balancing. This feature improves the LFA coverage when used with MPLS LDP (MLDP), there's no need of an extra protocol in the control plane.

Restrictions for Remote LFA for MLDP

- MLDP Node protection is not supported.
- Only Link Level protection for MLDP LFA FRR is supported.
- The detection of local/ remote link failure and switch over to the repair path is performed within 100 msec irrespective of the FRR scale.
- RLFA FRR in MLDP for IPv6 is not supported.
- RLFA FRR for Port-channel is not supported.
- Maximum supported Data Multicast Distribution Trees (MDT) for RLFA FRR is 750.
- Make Before Break (MBB) timer should be configured based on the scale of prefixes and P2MP trees configured.
- Label Distribution Protocol (LDP), Graceful Restart (GR) and MBB are mandatory to manage new and old Label Switch Path (LSP).
- Duplicate traffic is observed during cutover until GR timer expires. Duplicate traffic is dropped in the merge node and is not received by the receiver.

- RLFA over ECMP paths for mLDP is not supported.
- You must configure microloop avoidance under the IGP instance to achieve the desired convergence parameters.



Note Microloop avoidance may not work when Interior Gateway Protocol (IGP) is not receiving the interface down event to trigger the microloop avoidance timer. In such cases to avoid traffic drop due to IGP convergence, you have to configure BFD over the RLFA enabled links with 3.3-msec link down timers. This enables BFD to send link down notification within 9.9 msec.

How to Configure Loop-Free Alternate Fast Reroute

To enable loop-free alternate fast reroute support for L2VPNs, VPLS, TDM pseudowires and VPWS, you must configure LFA FRR for the routing protocol. You can enable LFA FRR using ISIS or OSPF configurations.

- For information on configuring LFA FRR using OSPF, see [OSPFv2 Loop-Free Alternate Fast Reroute](#) in the *IP Routing: OSPF Configuration Guide*.
- For information on configuring Remote LFA FRR using OSPF, see [OSPF IPv4 Remote Loop-Free Alternate IP Fast Reroute](#) in the *IP Routing: OSPF Configuration Guide*.
- For information on configuring Remote LFA FRR using ISIS on the Cisco ASR 903, see [Configuring IS-IS Remote Loop-Free Alternate Fast Reroute, on page 94](#).

Configuring IS-IS Remote Loop-Free Alternate Fast Reroute

The following additional configurations are mandatory:

- **mpls ldp discovery targeted-hello accept**

Procedure

	Command or Action	Purpose
Step 1	enable Example: Device> enable	Enables privileged EXEC mode. <ul style="list-style-type: none"> • Enter your password if prompted.
Step 2	configure terminal Example: Device# configure terminal	Enters global configuration mode.
Step 3	router isis [area-tag] Example:	Enables the IS-IS routing protocol and specifies an IS-IS process. <ul style="list-style-type: none"> • Enters router configuration mode.

	Command or Action	Purpose
	<code>Device(config)# router isis ipfrr</code>	
Step 4	fast-reroute per-prefix {level-1 level-2} {all route-map route-map-name} Example: <code>Device (config-router)# fast-reroute per-prefix level-1 all</code>	Enables per-prefix FRR. <ul style="list-style-type: none"> • Configure the all keyword to protect all prefixes.
Step 5	fast-reroute remote-lfa {level-1 level-2} mpls-ldp [maximum-metric metric-value] Example: <code>Device(config-router)# fast-reroute remote-lfa level-1 mpls-ldp</code>	Configures an FRR path that redirects traffic to a remote LFA tunnel for either level 1 or level 2 packets. <ul style="list-style-type: none"> • Use the maximum-metric metric-value keyword-argument pair to specify the maximum metric value required to reach the release node.
Step 6	end Example: <code>Device(config-router)# end</code>	Exits router configuration mode and enters privileged EXEC mode.

Recommended Configurations ISIS

For optimal results with remote LFA FRR, it is recommended that you use the following SFP timers:

- ISIS
 - `spf-interval 5 50 200`
 - `prc-interval 5 50 200`
 - `sp-gen-interval 5 50 200`
 - `fast-flood 10`
- Globally configure the MPLS IGP hold-down timer to avoid an indefinite wait by IGP for synchronization using the `mpls ldp igp sync holdown 2000` command.

Example: Configuring IS-IS Remote Loop-Free Alternate Fast Reroute

The following example shows how to enable remote LFA FRR:

```
Router(config)# router isis
Router(config)# fast-reroute per-prefix level-1 all
Router(config)# fast-reroute per-prefix level-2 all
Router(router-config)# fast-reroute remote-lfa level-1 mpls-ldp
Router(router-config)# fast-reroute remote-lfa level-2 mpls-ldp
```

Example: Configuring Remote LFA FRR with VPLS

Example: Configuration of Remote LFA FRR with Interior Gateway Protocol (IGP)

```
router isis hp
 net 49.0101.0000.0000.0802.00
 is-type level-2-only
 ispf level-2
 metric-style wide
 fast-flood
 set-overload-bit on-startup 180
 max-lsp-lifetime 65535
 lsp-refresh-interval 65000
 spf-interval 5 50 200
 prc-interval 5 50 200
 lsp-gen-interval 5 5 200
 no hello padding
 log-adjacency-changes
 nsf cisco
 fast-reroute per-prefix level-1 all
 fast-reroute per-prefix level-2 all
 fast-reroute remote-lfa level-1 mpls-ldp
 fast-reroute remote-lfa level-2 mpls-ldp
 passive-interface Loopback0
 mpls ldp sync
 mpls traffic-eng router-id Loopback0
 mpls traffic-eng level-2
```

Example: Configuration of Remote LFA FRR with VPLS at the interface level.

```
!
interface GigabitEthernet0/3/3
 ip address 198.51.100.1 255.255.255.0
 ip router isis hp
 logging event link-status
 load-interval 30
 negotiation auto
 mpls ip
 mpls traffic-eng tunnels
 isis network point-to-point
end
!
```

Example: Configuration of remote LFA FRR with VPLS at the global level.

```
!
12 vfi Test-2000 manual
 vpn id 2010
 bridge-domain 2010
 neighbor 192.0.2.1 encapsulation mpls
!
```

Example: Configuration of remote LFA FRR with VPLS at Access side.

```
!
interface TenGigabitEthernet0/2/0
 no ip address
 service instance trunk 1 ethernet
 encapsulation dot1q 12-2012
 rewrite ingress tag pop 1 symmetric
```

```
bridge-domain from-encapsulation
!
```

How to Configure OSPF IPv4 Remote Loop-Free Alternate IP Fast Reroute

Configuring a Remote LFA Tunnel

Perform this task to configure a per-prefix LFA FRR path that redirects traffic to a remote LFA tunnel.

Procedure

	Command or Action	Purpose
Step 1	enable Example: Device> enable	Enables privileged EXEC mode. <ul style="list-style-type: none"> • Enter your password if prompted.
Step 2	configure terminal Example: Device# configure terminal	Enters global configuration mode.
Step 3	router ospf process-id Example: Device(config)# router ospf 10	Enables OSPF routing and enters router configuration mode.
Step 4	fast-reroute per-prefix remote-lfa [area area-id] tunnel mpls-ldp Example: Device(config-router)# fast-reroute per-prefix remote-lfa area 2 tunnel mpls-ldp	Configures a per-prefix LFA FRR path that redirects traffic to a remote LFA tunnel via MPLS-LDP. <ul style="list-style-type: none"> • Use the area area-id keyword and argument to specify an area in which to enable LFA FRR.

Recommended Configurations OSPF

For optimal results with remote LFA FRR, it is recommended that you use the following SFP timers:

- timers throttle spf 50 200 5000
- timers throttle lsa 50 200 5000
- timers lsa arrival 100
- timers pacing flood 33



Note ISPF should be disabled.

Configuring the Maximum Distance to a Tunnel Endpoint

Perform this task to configure the maximum distance to the tunnel endpoint in a per-prefix LFA FRR path that redirects traffic to a remote LFA tunnel.

Procedure

	Command or Action	Purpose
Step 1	enable Example: Device> enable	Enables privileged EXEC mode. <ul style="list-style-type: none"> • Enter your password if prompted.
Step 2	configure terminal Example: Device# configure terminal	Enters global configuration mode.
Step 3	router ospf <i>process-id</i> Example: Device(config)# router ospf 10	Enables OSPF routing and enters router configuration mode.
Step 4	fast-reroute per-prefix remote-lfa [area <i>area-id</i>] maximum-cost <i>distance</i> Example: Device(config-router)# fast-reroute per-prefix remote-lfa area 2 maximum-cost 30	Configures the maximum distance to the tunnel endpoint in a per-prefix LFA FRR path that redirects traffic to a remote LFA tunnel. <ul style="list-style-type: none"> • Use the area <i>area-id</i> keyword and variable to specify an area in which to enable LFA FRR.

Configuring Remote LFA FRR for MLDP

Perform this task to configure the LDP based Remote LFA FRR for MLDP.



Note Ensure to configure a carrier delay down of 1 second on all core interfaces.

You must configure the **mpls mldp forwarding recursive** command to enable recursive forwarding. Do not disable this command while configuring Remote LFA MLDP.

Procedure

	Command or Action	Purpose
Step 1	enable Example:	Enables privileged EXEC mode. Enter your password if prompted.

	Command or Action	Purpose
	<code>Router enable</code>	
Step 2	configure terminal Example: <code>Router# configure terminal</code>	Enters global configuration mode.
Step 3	mpls ldp graceful-restart Example: <code>Router(config)# mpls ldp graceful-restart</code>	Enables the router to protect the LDP bindings and MPLS forwarding state during a disruption in service.
Step 4	mpls traffic-eng tunnels Example: <code>Router(config)# mpls traffic-eng tunnels</code>	Enables MPLS traffic engineering tunnel signaling on a device.
Step 5	mpls ldp discovery targeted-hello accept Example: <code>Router(config)# mpls ldp discovery targeted-hello accept</code>	Enables MPLS LDP targeted discovery on a device.
Step 6	mpls mldp make-before-break delay 1000 Example: <code>Router(config)# mpls mldp make-before-break delay 1000</code>	Enables MPLS MLDP MBB on a device.
Step 7	end Example: <code>Router(config)# end</code>	Exits router configuration mode and enters privileged EXEC mode.

Configuring IGP based Remote LFA for MLDP

Perform this task to configure the IGP based Remote LFA MLDP.

Procedure

	Command or Action	Purpose
Step 1	enable Example: <code>Router enable</code>	Enables privileged EXEC mode. Enter your password if prompted.
Step 2	configure terminal Example: <code>Router# configure terminal</code>	Enters global configuration mode.

	Command or Action	Purpose
Step 3	router ospf <i>process-id</i> Example: Router(config-router)# router ospf 10	Enables OSPF routing and enters router configuration mode.
Step 4	microloop avoidance rib-update-delay <i>delay-time</i> Example: Router(config-router)# microloop avoidance rib-update-delay 60000	Specifies the amount of time the node uses the microloop avoidance policy before updating its forwarding table. The delay-time is in milliseconds. The range is from 1-60000.
Step 5	fast-reroute per-prefix enable prefix-priority <i>priority-level</i> Example: Router(config-router)# fast-reroute per-prefix enable prefix-priority low	Enables repair-path computation and selects the priority level for repair paths. Low priority specifies that all prefixes have the same eligibility for protection. High priority specifies that only high-priority prefixes are protected.
Step 6	fast-reroute per-prefix remote-lfa [<i>area area-id</i>] tunnel mpls-ldp Example: Router(config-router)# fast-reroute per-prefix remote-lfa area 0 tunnel mpls-ldp	Configures a per-prefix LFA FRR path that redirects traffic to a remote LFA tunnel via MPLS-LDP. Use the area area-id keyword and argument to specify an area in which to enable LFA FRR.
Step 7	fast-reroute keep-all-paths Example: Router(config-router)# fast-reroute keep-all-paths	Specifies creating a list of repair paths considered for LFA FRR.
Step 8	end Example: Router(config)# end	Exits router configuration mode and enters privileged EXEC mode.

Verifying Remote LFA for MLDP



Note The prefix 3.3.3.3 is mLDP Next Hop (NH) in the direction of receiver.

```
Router#show ip cef 3.3.3.3 internal
3.3.3.3/32, epoch 2, RIB[I], refcnt 9, per-destination sharing
sources: RIB, RR, LTE
feature space:
  IPRM: 0x00028000
  Broker: linked, distributed at 1st priority
  LFD: 3.3.3.3/32 1 local label
  dflt local label info: global/16 [0x3]
  contains path extension list
```



```

dflt disposition chain 0x37D08728
  label implicit-null
  FRR Primary
    <primary: IP adj out of GigabitEthernet0/0/5, addr 10.1.1.2>
dflt label switch chain 0x37D08488
  label implicit-null
  FRR Primary
    <primary: TAG adj out of GigabitEthernet0/0/5, addr 10.1.1.2>
subblocks:
  3 RR sources [no flags]
    non-eos chain [implicit-null|17](ptr:0x37D08488)-(local:16)
ifnums:
  GigabitEthernet0/0/5(12): 10.1.1.2
  MPLS-Remote-Lfa2(47)
path list 3711ACA0, 3 locks, per-destination, flags 0x49 [shble, rif, hwcn]
  path 2A05F610, share 1/1, type attached nexthop, for IPv4, flags [has-rpr]
    MPLS short path extensions: [none] MOI flags = 0x21 label implicit-null
    nexthop 10.1.1.2 GigabitEthernet0/0/5 label
[implicit-null|17](ptr:0x37D08728)-(local:16), IP adj out of GigabitEthernet0/0/5, addr
10.1.1.2 379E4940
  repair: attached-nexthop 5.5.5.5 MPLS-Remote-Lfa2 (2A05F2E0)
  path 2A05F2E0, share 1/1, type attached nexthop, for IPv4, flags [rpr, rpr-only]
  nexthop 5.5.5.5 MPLS-Remote-Lfa2, repair, IP midchain out of MPLS-Remote-Lfa2 379E5740

output chain:
  label [implicit-null|17](ptr:0x37D08728)-(local:16)
  FRR Primary (0x36EE6520)
    <primary: IP adj out of GigabitEthernet0/0/5, addr 10.1.1.2 379E4940>
    <repair: TAG midchain out of MPLS-Remote-Lfa2 379E7340
      label 25-(local:24)
      TAG adj out of GigabitEthernet0/1/7, addr 60.1.1.2 379E4F40>

```

The following is sample output from the **show ip mfib vrf** command:

```

Router3#show ip mfib vrf vrf1 232.0.0.1
Entry Flags: C - Directly Connected, S - Signal, IA - Inherit A flag,
             ET - Data Rate Exceeds Threshold, K - Keepalive
             DDE - Data Driven Event, HW - Hardware Installed
             ME - MoFRR ECMP entry, MNE - MoFRR Non-ECMP entry, MP - MFIB
             MoFRR Primary, RP - MRIB MoFRR Primary, P - MoFRR Primary
             MS - MoFRR Entry in Sync, MC - MoFRR entry in MoFRR Client,
             e - Encap helper tunnel flag.
I/O Item Flags: IC - Internal Copy, NP - Not platform switched,
                NS - Negate Signalling, SP - Signal Present,
                A - Accept, F - Forward, RA - MRIB Accept, RF - MRIB Forward,
                MA - MFIB Accept, A2 - Accept backup,
                RA2 - MRIB Accept backup, MA2 - MFIB Accept backup

Forwarding Counts: Pkt Count/Pkts per second/Avg Pkt Size/Kbits per second
Other counts:      Total/RPF failed/Other drops
I/O Item Counts:  HW Pkt Count/FS Pkt Count/PS Pkt Count  Egress Rate in pps
VRF vrf1
(100.1.1.2,232.0.0.1) Flags: HW
SW Forwarding: 0/0/0/0, Other: 0/0/0
HW Forwarding: 6106/1/100/1, Other: 0/0/0
GigabitEthernet0/1/0 Flags: A
Lspvif2, LSM/6, RPF-ID: *, Flags: F
Pkts: 0/0/0 Rate: 0 pps

```

The following is sample output from the **show adjacency lspvif 2 internal** command:

```

Router#show adjacency lspvif2 internal
Protocol Interface Address
IP        Lspvif2 225.0.0.0(2) (incomplete)
          0 packets, 0 bytes

```

```

epoch 0
sourced in sev-epoch 80
punt (rate-limited) packets
no src set
L3 mtu 1500
Flags (0x882)
Fixup disabled
HWIDB/IDB pointers 0x3831A6DC/0x3929EAA0
IP redirect disabled
Switching vector: IPv4 incomplete adj oce
IPv4 MFIB wire 0x3653E020
LSM-ID: 0x0
Platform adj-id: 0xF8000311, 0x0, tun_qos_dpidx:0

Adjacency pointer 0x379E4740
Next-hop 225.0.0.0
225.0.0.0(4)
connectionid 6
0 packets, 0 bytes
epoch 0
sourced in sev-epoch 80
empty encap string
Multicast
Next chain element:
  replicate
    0: label 28
      label [implicit-null|17] (ptr:0x37D08488)-(local:16)

FRR Primary (0x31EF4540)
  <primary: TAG adj out of GigabitEthernet0/0/5,
  <repair: TAG midchain out of MPLS-Remote-Lfa2
    label 25-(local:24)
    TAG adj out of GigabitEthernet0/1/7,

parent oce 0x37971348
L3 mtu 1500
Flags (0x8C6)
Fixup disabled
HWIDB/IDB pointers 0x3831A6DC/0x3929EAA0
IP redirect disabled
Switching vector: IPv4 midchain adj oce
IPv4 MFIB wire 0x392A003C
LSM-ID: 0x6
MPLS subblock: flags 0x18 NSF PATH_SET
Path Set Id 0x00000006 Num Paths 1 Owner MLDP

path recursive 3.3.3.3 label 28 MOI flags 0x1
EOS output chain elements: replicate
  0: label 28
    label
[implicit-null|17] (ptr:0x37D08488)-(local:16)
  FRR Primary (0x31EF4540)
  <primary: TAG adj out of GigabitEthernet0/0/5,
  <repair: TAG midchain out of MPLS-Remote-Lfa2
    label 25-(local:24)
    TAG adj out of GigabitEthernet0/1/7,

NonEOS output chain elements: replicate
  0: label 28
    label

```

IP Lspvif2

addr 10.1.1.2 379E5140>

379E7340

addr 60.1.1.2 379E4F40>

Flags 0xD RefCount 3

addr 10.1.1.2 379E5140>

379E7340

addr 60.1.1.2 379E4F40>

```

[implicit-null|17] (ptr:0x37D08488)-(local:16)
    FRR Primary (0x31EF4540)
    <primary: TAG adj out of GigabitEthernet0/0/5,
addr 10.1.1.2 379E5140>
    <repair: TAG midchain out of MPLS-Remote-Lfa2
379E7340
    label 25-(local:24)
    TAG adj out of GigabitEthernet0/1/7,
addr 60.1.1.2 379E4F40>
    oce chain (0x37971348):
    replicate
    0: label 28
    label
[implicit-null|17] (ptr:0x37D08488)-(local:16)
    FRR Primary (0x31EF4540)
    <primary: TAG adj out of GigabitEthernet0/0/5,
addr 10.1.1.2 379E5140>
    <repair: TAG midchain out of MPLS-Remote-Lfa2
379E7340
    label 25-(local:24)
    TAG adj out of GigabitEthernet0/1/7,
addr 60.1.1.2 379E4F40>
    adj-sb send-slotmask: 0x0
    Platform adj-id: 0x10EC, 0x0, tun_qos_dpidx:0
Adjacency pointer 0x379E4540
Next-hop 225.0.0.0
IP      Lspvif2 227.0.0.0(3)
    connectionid 1
    0 packets, 0 bytes
    epoch 0
    sourced in sev-epoch 80
    empty encap string
    Inject p2mp Multicast
    L3 mtu 17940
    mtu update from interface suppressed
    Flags (0x8A6)
    Fixup disabled
    HWIDB/IDB pointers 0x3831A6DC/0x3929EAA0
    IP redirect disabled
    Switching vector: IPv4 no fixup adj oce
    LSM-ID: 0x1
    Platform adj-id: 0xF8000314, 0x0, tun_qos_dpidx:0
Adjacency pointer 0x379E7540
Next-hop 227.0.0.0
IPV6   Lspvif2 FF0E::(2) (incomplete)
    0 packets, 0 bytes
    epoch 0
    sourced in sev-epoch 80
    punt (rate-limited) packets
    no src set
    L3 mtu 1500
    Flags (0x1882)
    Fixup disabled
    HWIDB/IDB pointers 0x3831A6DC/0x3929EAA0
    IP redirect enabled
    Switching vector: IPv6 adjacency oce
    IPv6 MFIB wire 0x3653E054
    LSM-ID: 0x0
    Platform adj-id: 0xF8000312, 0x0, tun_qos_dpidx:0
Adjacency pointer 0x379E5940
Next-hop FF0E::

```

```

IPV6      Lspvif2      FF0E::(3)
                    connectionid 5
                    0 packets, 0 bytes
                    epoch 0
                    sourced in sev-epoch 80
                    empty encap string
                    Multicast
                    Next chain element:
                      label ipv6-explicit-null
                      TAG midchain out of Lspvif2, addr FF0E::, cid: 5

379E5D40
                    replicate
                    parent oce 0x3791B5B0
                    L3 mtu 1500
                    Flags (0x18C6)
                    Fixup disabled
                    HWIDB/IDB pointers 0x3831A6DC/0x3929EAA0
                    IP redirect enabled
                    Switching vector: IPv6 midchain adjacency oce
                    LSM-ID: 0x5
                    MPLS subblock: flags 0x8 NSF
                      Lspvif2 FF0E:: label ipv6-explicit-null
                      oce chain (0x3791B5B0):
                        label ipv6-explicit-null
                        TAG midchain out of Lspvif2, addr FF0E::, cid: 5

379E5D40
                    replicate
                    adj-sb send-slotmask: 0x0
                    Platform adj-id: 0x10DD, 0x0, tun_qos_dpidx:0

TAG      Lspvif2      Adjacency pointer 0x379E5F40
                    Next-hop FF0E::
                    FF0E::(4)
                    connectionid 5
                    0 packets, 0 bytes
                    epoch 0
                    sourced in sev-epoch 80
                    empty encap string
                    Multicast
                    Next chain element:
                      replicate
                      parent oce 0x37970E50
                      L3 mtu 17940
                      Flags (0x8C6)
                      Fixup disabled
                      HWIDB/IDB pointers 0x3831A6DC/0x3929EAA0
                      IP redirect disabled
                      Switching vector: MPLS midchain adjacency oce
                      LSM-ID: 0x5
                      MPLS subblock: flags 0x18 NSF PATH_SET
                        Path Set Id 0x00000005  Num Paths 0  Owner MLDP

Flags 0xD  RefCount 3
                    EOS output chain elements: replicate
                    NonEOS output chain elements: replicate
                    oce chain (0x37970E50):
                      replicate
                      adj-sb send-slotmask: 0x0
                      Platform adj-id: 0x10DE, 0x0, tun_qos_dpidx:0

                    Adjacency pointer 0x379E5D40
                    Next-hop FF0E::
                    IPV6      Lspvif2      FFFF::(3)
                    connectionid 1
                    0 packets, 0 bytes

```

```

epoch 0
sourced in sev-epoch 80
empty encap string
Inject p2mp Multicast
L3 mtu 1500
Flags (0x1886)
Fixup disabled
HWIDB/IDB pointers 0x3831A6DC/0x3929EAA0
IP redirect enabled
Switching vector: IPv6 adjacency oce
LSM-ID: 0x1
Platform adj-id: 0xF8000315, 0x0, tun_qos_dpidx:0

Adjacency pointer 0x379E7940
Next-hop FFFF::
FFFF::(3)
connectionid 1
0 packets, 0 bytes
epoch 0
sourced in sev-epoch 80
empty encap string
Inject p2mp Multicast
L3 mtu 17940
Flags (0x886)
Fixup disabled
HWIDB/IDB pointers 0x3831A6DC/0x3929EAA0
IP redirect disabled
Switching vector: MPLS adjacency oce
LSM-ID: 0x1
Platform adj-id: 0x10DA, 0x0, tun_qos_dpidx:0

Adjacency pointer 0x379E5B40
Next-hop FFFF::

Router#
TAG      Lspvif2

```

Verifying Loop-Free Alternate Fast Reroute

Use one or more of the following commands to verify the LFA FRR configuration

- **show ip cef network-prefix internal**
- **show mpls infrastructure lfd pseudowire internal**
- **show platform hardware pp active feature cef database ipv4 network-prefix**

Example: Verifying LFA FRR with L2VPN

show ip cef internal

The following is sample output from the **show ip cef internal** command:

```

Device# show ip cef 16.16.16.16 internal
16.16.16.16/32, epoch 2, RIB[I], refcount 7, per-destination sharing
sources: RIB, RR, LTE
feature space:
  IPRM: 0x00028000
  Broker: linked, distributed at 1st priority
  LFD: 16.16.16.16/32 1 local label

```

```

    local label info: global/17
        contains path extension list
        disposition chain 0x3A3C1DF0
        label switch chain 0x3A3C1DF0
subblocks:
  1 RR source [no flags]
    non-eos chain [16|44]
ifnums:
  GigabitEthernet0/0/2(9): 7.7.7.2
  GigabitEthernet0/0/7(14): 7.7.17.9
  path 35D61070, path list 3A388FA8, share 1/1, type attached nexthop, for IPv4, flags
has-repair
  MPLS short path extensions: MOI flags = 0x20 label 16
  nexthop 7.7.7.2 GigabitEthernet0/0/2 label [16|44], adjacency IP adj out of
GigabitEthernet0/0/2, addr 7.7.7.2 35E88520
  repair: attached-nexthop 7.7.17.9 GigabitEthernet0/0/7 (35D610E0)
  path 35D610E0, path list 3A388FA8, share 1/1, type attached nexthop, for IPv4, flags
repair, repair-only
  nexthop 7.7.17.9 GigabitEthernet0/0/7, repair, adjacency IP adj out of GigabitEthernet0/0/7,
  addr 7.7.17.9 3A48A4E0
  output chain: label [16|44]
  FRR Primary (0x35D10F60)
  <primary: TAG adj out of GigabitEthernet0/0/2, addr 7.7.7.2 35E88380>
  <repair: TAG adj out of GigabitEthernet0/0/7, addr 7.7.17.9 3A48A340>
Rudy17#show mpls infrastructure lfd pseudowire internal
PW ID: 1VC ID: 4, Nexthop address: 16.16.16.16
SSM Class: SSS HW
Segment Count: 1
VCCV Types Supported: cw ra ttl
Imposition details:
Label stack {22 16}, Output interface: Gi0/0/2
Preferred path: not configured
Control Word: enabled, Sequencing: disabled
FIB Non IP entry: 0x35D6CEEC
Output chain: ATom Imp (locks 4) label 22 label [16|44]
  FRR Primary (0x35D10F60)
  <primary: TAG adj out of GigabitEthernet0/0/2, addr 7.7.7.2 35E88380>
Disposition details:
Local label: 16
Control Word: enabled, Sequencing: disabled
SSS Switch: 3976200193
Output chain: mpls_eos( connid router-alert ATom Disp (locks 5)/ drop)

```

show mpls infrastructure lfd pseudowire internal

The following is sample output from the **show mpls infrastructure lfd pseudowire internal** command:

```

Device# show mpls infrastructure lfd pseudowire internal
PW ID: 1VC ID: 4, Nexthop address: 16.16.16.16
SSM Class: SSS HW
Segment Count: 1
VCCV Types Supported: cw ra ttl
Imposition details:
Label stack {22 16}, Output interface: Gi0/0/2
Preferred path: not configured
Control Word: enabled, Sequencing: disabled
FIB Non IP entry: 0x35D6CEEC
Output chain: ATom Imp (locks 4) label 22 label [16|44]
  FRR Primary (0x35D10F60)
  <primary: TAG adj out of GigabitEthernet0/0/2, addr 7.7.7.2 35E88380>
Disposition details:

```

```

Local label: 16
Control Word: enabled, Sequencing: disabled
SSS Switch: 3976200193
Output chain: mpls_eos( connid router-alert ATOM Disp (locks 5)/ drop)

```

show platform hardware pp active feature cef database

The following is sample output from the **show platform hardware pp active feature cef database** command:

```

Device# show platform hardware pp active feature cef database ipv4 16.16.16.16/32
=== CEF Prefix ===
16.16.16.16/32 -- next hop: UEA Label OCE (PI:0x104abee0, PD:0x10e6b9c8)
                Route Flags: (0)
                Handles (PI:0x104ab6e0) (PD:0x10e68140)

HW Info:
  TCAM handle: 0x0000023f    TCAM index: 0x0000000d
  FID index   : 0x0000f804    EAID       : 0x0000808a
  MET        : 0x0000400c    FID Count  : 0x00000000

=== Label OCE ===
Label flags: 4
Num Labels: 1
Num Bk Labels: 1
Out Labels: 16
Out Backup Labels: 44
Next OCE Type: Fast ReRoute OCE; Next OCE handle: 0x10e6f428

=== FRR OCE ===
FRR type      : IP FRR
FRR state     : Primary
Primary IF's gid : 3
Primary FID   : 0x0000f801
FIFC entries  : 32
PPO handle    : 0x00000000
Next OCE     : Adjacency (0x10e63b38)
Bkup OCE     : Adjacency (0x10e6e590)

=== Adjacency OCE ===
Adj State: COMPLETE(0)  Address: 7.7.7.2
Interface: GigabitEthernet0/0/2  Protocol: TAG
mtu:1500, flags:0x0, fixups:0x0, encap_len:14
Handles (adj_id:0x00000039) (PI:0x1041d410) (PD:0x10e63b38)
Rewrite Str: d0:c2:82:17:8a:82:d0:c2:82:17:f2:02:88:47

HW Info:
  FID index: 0x0000f486    EL3 index: 0x00001003    EL2 index: 0x00000000
  EL2RW    : 0x00000107    MET index: 0x0000400c    EAID      : 0x00008060
  HW ADJ FLAGS: 0x40
  Hardware MAC Rewrite Str: d0:c2:82:17:8a:82:08:00:40:00:0d:02

=== Adjacency OCE ===
Adj State: COMPLETE(0)  Address: 7.7.17.9
Interface: GigabitEthernet0/0/7  Protocol: TAG
mtu:1500, flags:0x0, fixups:0x0, encap_len:14
Handles (adj_id:0x00000012) (PI:0x104acbd0) (PD:0x10e6e590)
Rewrite Str: d0:c2:82:17:c9:83:d0:c2:82:17:f2:07:88:47

HW Info:
  FID index: 0x0000f49d    EL3 index: 0x00001008    EL2 index: 0x00000000
  EL2RW    : 0x00000111    MET index: 0x00004017    EAID      : 0x0000807d

```

```
HW ADJ FLAGS: 0x40
Hardware MAC Rewrite Str: d0:c2:82:17:c9:83:08:00:40:00:0d:07
```

Configuration Examples for OSPF IPv4 Remote Loop-Free Alternate IP Fast Reroute

Example: Configuring a Remote LFA Tunnel

The following example shows how to configure a remote per-prefix LFA FRR in area 2. The remote tunnel type is specified as MPLS-LDP:

```
Router(config-router)# fast-reroute per-prefix remote-lfa area 2 tunnel mpls-ldp
```

Example: Configuring the Maximum Distance to a Tunnel Endpoint

The following example shows how to set a maximum cost of 30 in area 2:

```
Router(config-router)# fast-reroute per-prefix remote-lfa area 2 maximum-cost 30
```

Example: Verifying Tunnel Interfaces Created by OSPF IPv4 Remote LFA IPFRR

The following example displays information about tunnel interfaces created by OSPF IPv4 LFA IPFRR:

```
Router# show ip ospf fast-reroute remote-lfa tunnels

    OSPF Router with ID (192.168.1.1) (Process ID 1)
    Area with ID (0)
    Base Topology (MTID 0)

Interface MPLS-Remote-Lfa3
Tunnel type: MPLS-LDP
Tailend router ID: 192.168.3.3
Termination IP address: 192.168.3.3
Outgoing interface: Ethernet0/0
First hop gateway: 192.168.14.4
Tunnel metric: 20
Protects:
  192.168.12.2 Ethernet0/1, total metric 30
```

Verifying Remote Loop-Free Alternate Fast Reroute with VPLS

Example: Verifying Remote LFA FRR with VPLS

show ip cef internal

The following is sample output from the **show ip cef internal** command:

```
Router# show ip cef 198.51.100.2/32 internal

198.51.100.2/32, epoch 2, RIB[I], refcount 7, per-destination sharing
sources: RIB, RR, LTE
feature space:
  IPRM: 0x00028000
  Broker: linked, distributed at 1st priority
  LFD: 198.51.100.2/32 1 local label
  local label info: global/2033
    contains path extension list
    disposition chain 0x46764E68
    label switch chain 0x46764E68
subblocks:
  1 RR source [heavily shared]
  non-eos chain [explicit-null|70]
ifnums:
  TenGigabitEthernet0/1/0(15): 192.0.2.10
  MPLS-Remote-Lfa2(46)
  path 44CE1290, path list 433CF8C0, share 1/1, type attached nexthop, for IPv4, flags
  has-repair
    MPLS short path extensions: MOI flags = 0x21 label explicit-null
    nexthop 192.0.2.10 TenGigabitEthernet0/1/0 label [explicit-null|70], adjacency IP adj out
    of TenGigabitEthernet0/1/0, addr 192.0.2.10 404B3960
    repair: attached-nexthop 192.0.2.1 MPLS-Remote-Lfa2 (44CE1300)
  path 44CE1300, path list 433CF8C0, share 1/1, type attached nexthop, for IPv4, flags
  repair, repair-only
    nexthop 192.0.2.1 MPLS-Remote-Lfa2, repair, adjacency IP midchain out of MPLS-Remote-Lfa2
    404B3B00
    output chain: label [explicit-null|70]
    FRR Primary (0x3E25CA00)
    <primary: TAG adj out of TenGigabitEthernet0/1/0, addr 192.168.101.22 404B3CA0>
    <repair: TAG midchain out of MPLS-Remote-Lfa2 404B37C0 label 37 TAG adj out of
    GigabitEthernet0/3/3, addr 192.0.2.14 461B2F20>
```

show ip cef detail

The following is sample output from the **show ip cef detail** command:

```
Router# show ip cef 198.51.100.2/32 detail

198.51.100.2/32, epoch 2
  local label info: global/2033
  1 RR source [heavily shared]
  nexthop 192.0.2.14 TenGigabitEthernet0/1/0 label [explicit-null|70]
    repair: attached-nexthop 192.0.2.1 MPLS-Remote-Lfa2
  nexthop 192.0.2.1 MPLS-Remote-Lfa2, repair
!
```



```

Next OCE Type: Adjacency; Next OCE handle: 0x12943a00
=== Adjacency OCE ===
Adj State: COMPLETE(0)   Address: 30.1.1.1
Interface: GigabitEthernet0/3/3   Protocol: TAG
mtu:1500, flags:0x0, fixups:0x0, encap_len:14
Handles (adj_id:0x0000378e) (PI:0x10909738) (PD:0x12943a00)
Rewrite Str: c8:f9:f9:8d:01:b3:c8:f9:f9:8d:04:33:88:47

HW Info:
FID index: 0x00008c78   EL3 index: 0x0000101c   EL2 index: 0x00000000
EL2RW   : 0x00000109   MET index: 0x0000400e   EAID      : 0x0001cf4b
HW ADJ FLAGS: 0x40
Hardware MAC Rewrite Str: c8:f9:f9:8d:01:b3:08:00:40:00:0d:33
    
```

show mpls l2transport detail

The following is sample output from the **show mpls l2transport detail** command:

```

Router# show mpls l2transport vc 2000 detail

Local interface: VFI Test-1990 vfi up
Interworking type is Ethernet
Destination address: 192.0.2.1, VC ID: 2000, VC status: up
Output interface: Te0/1/0, imposed label stack {0 2217}
Preferred path: not configured
Default path: active
Next hop: 192.51.100.22
Create time: 1d08h, last status change time: 1d08h
Last label FSM state change time: 1d08h
Signaling protocol: LDP, peer 192.0.51.1:0 up
Targeted Hello: 192.51.100.2(LDP Id) -> 192.51.100.200, LDP is UP
Graceful restart: configured and enabled
Non stop routing: not configured and not enabled
Status TLV support (local/remote) : enabled/supported
LDP route watch                   : enabled
Label/status state machine        : established, LruRru
Last local dataplane status rcvd: No fault
Last BFD dataplane status rcvd: Not sent
Last BFD peer monitor status rcvd: No fault
Last local AC circuit status rcvd: No fault
Last local AC circuit status sent: No fault
Last local PW i/f circ status rcvd: No fault
Last local LDP TLV status sent: No fault
Last remote LDP TLV status rcvd: No fault
    
```

Verifying Tunnel Interfaces Created by OSPF IPv4 Remote LFA IPFRR

Procedure

	Command or Action	Purpose
Step 1	enable Example:	Enables privileged EXEC mode. • Enter your password if prompted.

	Command or Action	Purpose
	Device> enable	
Step 2	show ip ospf fast-reroute remote-lfa tunnels Example: Device# show ip ospf fast-reroute remote-lfa tunnels	Displays information about the OSPF per-prefix LFA FRR configuration.

Additional References

Related Documents

Related Topic	Document Title
Cisco IOS commands	Cisco IOS Master Command List, All Releases
MPLS commands	Multiprotocol Label Switching Command Reference

Technical Assistance

Description	Link
The Cisco Support and Documentation website provides online resources to download documentation, software, and tools. Use these resources to install and configure the software and to troubleshoot and resolve technical issues with Cisco products and technologies. Access to most tools on the Cisco Support and Documentation website requires a Cisco.com user ID and password.	http://www.cisco.com/cisco/web/support/index.html



CHAPTER 5

Configuring Virtual Private LAN Services

Virtual Private LAN Services (VPLS) enables enterprises to link together their Ethernet-based LANs from multiple sites via the infrastructure provided by their service provider.

This module explains VPLS and how to configure it.

- [Prerequisites for Virtual Private LAN Services, on page 113](#)
- [Restrictions for Virtual Private LAN Services, on page 113](#)
- [Information About Virtual Private LAN Services, on page 114](#)
- [How to Configure Virtual Private LAN Services, on page 118](#)
- [Configuration Examples for Virtual Private LAN Services, on page 144](#)
- [Feature Information for Configuring Virtual Private LAN Services, on page 154](#)
- [Layer 2 Protocol Tunneling, on page 154](#)

Prerequisites for Virtual Private LAN Services

Before you configure Virtual Private LAN Services (VPLS), ensure that the network is configured as follows:

- Configure IP routing in the core so that provider edge (PE) devices can reach each other via IP.
- Configure Multiprotocol Label Switching (MPLS) in the core so that a label switched path (LSP) exists between PE devices.
- Configure a loopback interface for originating and terminating Layer 2 traffic. Ensure that PE devices can access the loopback interface of the other device. Note that the loopback interface is not required in all cases. For example, tunnel selection does not need a loopback interface when VPLS is directly mapped to a traffic engineering (TE) tunnel.
- Identify peer PE devices and attach Layer 2 circuits to VPLS at each PE device.

Restrictions for Virtual Private LAN Services

The following general restrictions apply to all transport types under Virtual Private LAN Services (VPLS):

- Split horizon is the default configuration to avoid broadcast packet looping and to isolate Layer 2 traffic. Split horizon prevents packets received from an emulated virtual circuit (VC) from being forwarded into another emulated VC. This technique is important for creating loop-free paths in a full-meshed network.

- If you do not enable the EFP feature template, then there is no traffic flow between EFP and VFI (when EFP is with Split Horizon group and VFI is default). But when you enable the EFP feature template, then there is traffic flow between EFP and VFI because of design limitations.
- Supported maximum values:
 - Total number of virtual forwarding instances (VFIs): 4096 (4 K)
 - Maximum combined number of edge and the core peer provider edge (PE) devices per VFI: VPLS 250 and hierarchical VPLS (H-VPLS) 500
 - Total number of VC: 12,288 (12 K)
- L2VPN traffic is not load balanced for inner payload src-ip, dst-ip, src-dst-ip hashing algorithms in the egress PoCh interface. We recommend you to use other hashing algorithms like src-mac, dst-mac, src-dst-mac.
- Software-based data plane is not supported.
- Auto-discovery mechanism is not supported.
- The Border Gateway Protocol (BGP) autodiscovery process does not support dynamic, hierarchical VPLS.
- Load sharing and failover on redundant customer-edge-provider-edge (CE-PE) links are not supported.
- The addition or removal of MAC addresses with Label Distribution Protocol (LDP) is not supported.
- VFI is supported only with **interface vlan** command.
- Point to Multipoint (P2MP) Resource Reservation Protocol (RSVP) for MPLS Traffic Engineering (MPLS-TE) is not supported over VPLS on the Cisco RSP2 and RSP3 routers.
- Traffic drops are observed for lower sized MPLS pseudowire packets.

Information About Virtual Private LAN Services

VPLS Overview

Virtual Private LAN Services (VPLS) enables enterprises to link together their Ethernet-based LANs from multiple sites via the infrastructure provided by their service provider. From the enterprise perspective, the service provider's public network looks like one giant Ethernet LAN. For the service provider, VPLS provides an opportunity to deploy another revenue-generating service on top of the existing network without major capital expenditures. Operators can extend the operational life of equipment in their network.

VPLS uses the provider core to join multiple attachment circuits together to simulate a virtual bridge that connects the multiple attachment circuits together. From a customer point of view, there is no topology for VPLS. All customer edge (CE) devices appear to connect to a logical bridge emulated by the provider core (see the figure below).

Figure 6: VPLS Topology

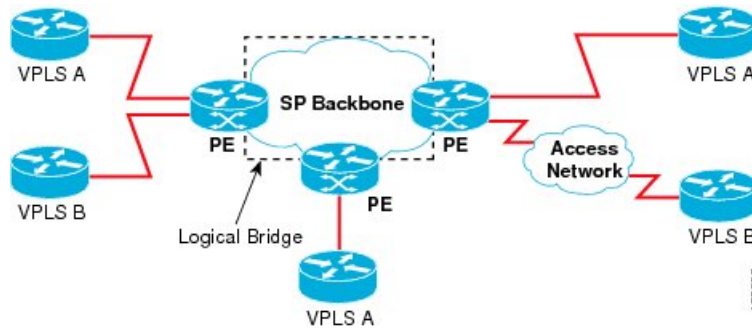

Full-Mesh Configuration

A full-mesh configuration requires a full mesh of tunnel label switched paths (LSPs) between all provider edge (PE) devices that participate in Virtual Private LAN Services (VPLS). With a full mesh, signaling overhead and packet replication requirements for each provisioned virtual circuit (VC) on a PE can be high.

You set up a VPLS by first creating a virtual forwarding instance (VFI) on each participating PE device. The VFI specifies the VPN ID of a VPLS domain, the addresses of other PE devices in the domain, and the type of tunnel signaling and encapsulation mechanism for each peer PE device.

The set of VFIs formed by the interconnection of the emulated VCs is called a VPLS instance; it is the VPLS instance that forms the logic bridge over a packet switched network. After the VFI has been defined, it needs to be bound to an attachment circuit to the CE device. The VPLS instance is assigned a unique VPN ID.

PE devices use the VFI to establish a full-mesh LSP of emulated VCs to all other PE devices in the VPLS instance. PE devices obtain the membership of a VPLS instance through static configuration using the Cisco IOS CLI.

A full-mesh configuration allows the PE device to maintain a single broadcast domain. When the PE device receives a broadcast, multicast, or unknown unicast packet on an attachment circuit (AC), it sends the packet out on all other ACs and emulated circuits to all other CE devices participating in that VPLS instance. The CE devices see the VPLS instance as an emulated LAN.

To avoid the problem of a packet looping in the provider core, PE devices enforce a “split-horizon” principle for emulated VCs. In a split horizon, if a packet is received on an emulated VC, it is not forwarded on any other emulated VC.

The packet forwarding decision is made by looking up the Layer 2 VFI of a particular VPLS domain.

A VPLS instance on a particular PE device receives Ethernet frames that enter on specific physical or logical ports and populates a MAC table similarly to how an Ethernet switch works. The PE device can use the MAC address to switch these frames into the appropriate LSP for delivery to the another PE device at a remote site.

If the MAC address is not available in the MAC address table, the PE device replicates the Ethernet frame and floods it to all logical ports associated with that VPLS instance, except the ingress port from which it just entered. The PE device updates the MAC table as it receives packets on specific ports and removes addresses not used for specific periods.

Static VPLS Configuration

Virtual Private LAN Services (VPLS) over Multiprotocol Label Switching-Transport Profile (MPLS-TP) tunnels allows you to deploy a multipoint-to-multipoint layer 2 operating environment over an MPLS-TP network for services such as Ethernet connectivity and multicast video. To configure static VPLS, you must specify a static range of MPLS labels using the **mpls label range** command with the **static** keyword.

H-VPLS

Hierarchical VPLS (H-VPLS) reduces signaling and replication overhead by using full-mesh and hub-and-spoke configurations. Hub-and-spoke configurations operate with split horizon to allow packets to be switched between pseudowires (PWs), effectively reducing the number of PWs between provider edge (PE) devices.



Note Split horizon is the default configuration to avoid broadcast packet looping.

Supported Features

Multipoint-to-Multipoint Support

In a multipoint-to-multipoint network, two or more devices are associated over the core network. No single device is designated as the Root node; all devices are considered as Root nodes. All frames can be exchanged directly between the nodes.

Non-Transparent Operation

A virtual Ethernet connection (VEC) can be transparent or non-transparent with respect to Ethernet protocol data units (PDUs). The VEC non-transparency allows users to have a Frame Relay-type service between Layer 3 devices.

Circuit Multiplexing

Circuit multiplexing allows a node to participate in multiple services over a single Ethernet connection. By participating in multiple services, the Ethernet connection is attached to multiple logical networks. Some examples of possible service offerings are VPN services between sites, Internet services, and third-party connectivity for intercompany communications.

MAC-Address Learning, Forwarding, and Aging

Provider edge (PE) devices must learn remote MAC addresses and directly attached MAC addresses on ports that face the external network. MAC address learning accomplishes this by deriving the topology and forwarding information from packets originating at customer sites. A timer is associated with stored MAC addresses. After the timer expires, the entry is removed from the table.

Jumbo Frame Support

Jumbo frame support provides support for frame sizes between 1548 and 9216 bytes. You use the CLI to establish the jumbo frame size for any value specified in the above range. The default value is 1500 bytes in any Layer 2/VLAN interface. You can configure jumbo frame support on a per-interface basis.

Q-in-Q Support and Q-in-Q to EoMPLS VPLS Support

With 802.1Q tunneling (Q-in-Q), the customer edge (CE) device issues VLAN-tagged packets and VPLS forwards these packets to a far-end CE device. Q-in-Q refers to the fact that one or more 802.1Q tags may be located in a packet within the interior of the network. As packets are received from a CE device, an additional VLAN tag is added to incoming Ethernet packets to segregate traffic from different CE devices. Untagged packets originating from a CE device use a single tag within the interior of the VLAN switched network, whereas previously tagged packets originating from the CE device use two or more tags.

VPLS Services

Transparent LAN Service

Transparent LAN Service (TLS) is an extension to the point-to-point port-based Ethernet over Multiprotocol Label Switching (EoMPLS), which provides bridging protocol transparency (for example, bridge protocol data units [BPDUs]) and VLAN values. Bridges see this service as an Ethernet segment. With TLS, the PE device forwards all Ethernet packets received from the customer-facing interface (including tagged and untagged packets, and BPDUs) as follows:

- To a local Ethernet interface or an emulated virtual circuit (VC) if the destination MAC address is found in the Layer 2 forwarding table.
- To all other local Ethernet interfaces and emulated VCs belonging to the same VPLS domain if the destination MAC address is a multicast or broadcast address or if the destination MAC address is not found in the Layer 2 forwarding table.



Note You must enable Layer 2 protocol tunneling to run the Cisco Discovery Protocol (CDP), the VLAN Trunking Protocol (VTP), and the Spanning-Tree Protocol (STP).

Ethernet Virtual Connection Service

Ethernet Virtual Connection Service (EVCS) is an extension to the point-to-point VLAN-based Ethernet over MPLS (EoMPLS) that allows devices to reach multiple intranet and extranet locations from a single physical port. With EVCS, the provider edge (PE) device forwards all Ethernet packets with a particular VLAN tag received from the customer-facing interface (excluding bridge protocol data units [BPDUs]) as follows:

- To a local Ethernet interface or to an emulated virtual circuit (VC) if the destination MAC address is found in the Layer 2 forwarding table.
- To all other local Ethernet interfaces and emulated VCs belonging to the same Virtual Private LAN Services (VPLS) domain if the destination MAC address is a multicast or a broadcast address or if the destination MAC address is not found in the Layer 2 forwarding table.



Note Because it has only local significance, the demultiplexing VLAN tag that identifies a VPLS domain is removed before the packet is forwarded to the outgoing Ethernet interfaces or emulated VCs.

How to Configure Virtual Private LAN Services

Provisioning a Virtual Private LAN Services (VPLS) link involves provisioning the associated attachment circuit and a virtual forwarding instance (VFI) on a provider edge (PE) device.

In Cisco IOS XE Release 3.7S, the L2VPN Protocol-Based CLIs feature was introduced. This feature provides a set of processes and an improved infrastructure for developing and delivering Cisco IOS software on various Cisco platforms. This feature introduces new commands and modifies or replaces existing commands to achieve a consistent functionality across Cisco platforms and provide cross-Operating System (OS) support.

This section consists of tasks that use the commands existing prior to Cisco IOS XE Release 3.7S and a corresponding task that uses the commands introduced or modified by the L2VPN Protocol-Based CLIs feature.

Configuring PE Layer 2 Interfaces on CE Devices

You can configure the Ethernet flow point (EFP) as a Layer 2 virtual interface. You can also select tagged or untagged traffic from a customer edge (CE) device.

Configuring 802.1Q Access Ports for Tagged Traffic from a CE Device



Note When Ethernet Virtual Connection Service (EVCS) is configured, a provider edge (PE) device forwards all Ethernet packets with a particular VLAN tag to a local Ethernet interface or emulated virtual circuit (VC) if the destination MAC address is found in the Layer 2 forwarding table.

Procedure

	Command or Action	Purpose
Step 1	enable Example: Device> enable	Enables privileged EXEC mode. • Enter your password if prompted.
Step 2	configure terminal Example: Device# configure terminal	Enters global configuration mode.
Step 3	interface <i>type number</i> Example: Device(config)# interface gigabitethernet 0/0/1	Specifies an interface and enters interface configuration mode.
Step 4	no ip address [<i>ip-address mask</i>] [secondary] Example:	Disables IP processing.

	Command or Action	Purpose
	<code>Device(config-if)# no ip address</code>	
Step 5	negotiation auto Example: <code>Device(config-if)# negotiation auto</code>	Enables the autonegotiation protocol to configure the speed, duplex, and automatic flow control of the Gigabit Ethernet interface.
Step 6	service instance <i>si-id</i> ethernet Example: <code>Device(config-if)# service instance 10 ethernet</code>	Specifies the service instance ID and enters service instance configuration mode.
Step 7	encapsulation dot1q <i>vlan-id</i> Example: <code>Device(config-if-srv)# encapsulation dot1q 200</code>	<p>Defines the matching criteria to map 802.1Q frames ingress on an interface to the appropriate service instance.</p> <p>Ensure that the interface on the adjoining customer edge (CE) device is on the same VLAN as this PE device.</p>
Step 8	bridge-domain <i>bd-id</i> Example: <code>Device(config-if-srv)# bridge-domain 100</code>	Binds a service instance to a bridge domain instance.
Step 9	end Example: <code>Device(config-if-srv)# end</code>	Exits service instance configuration mode and returns to privileged EXEC mode.

Configuring 802.1Q Access Ports for Tagged Traffic from a CE Device: Alternate Configuration



Note When Ethernet Virtual Connection Service (EVCS) is configured, the PE device forwards all Ethernet packets with a particular VLAN tag to a local Ethernet interface or an emulated virtual circuit (VC) if the destination MAC address is found in the Layer 2 forwarding table.

Procedure

	Command or Action	Purpose
Step 1	enable Example: <code>Device> enable</code>	<p>Enables privileged EXEC mode.</p> <ul style="list-style-type: none"> • Enter your password if prompted.

	Command or Action	Purpose
Step 2	configure terminal Example: Device# configure terminal	Enters global configuration mode.
Step 3	interface <i>type number</i> Example: Device(config)# interface gigabitethernet 0/0/1	Specifies an interface and enters interface configuration mode.
Step 4	no ip address [<i>ip-address mask</i>] [secondary] Example: Device(config-if)# no ip address	Disables IP processing.
Step 5	negotiation auto Example: Device(config-if)# negotiation auto	Enables the autonegotiation protocol to configure the speed, duplex, and automatic flow control of the Gigabit Ethernet interface.
Step 6	service instance <i>si-id</i> ethernet Example: Device(config-if)# service instance 10 ethernet	Specifies a service instance ID and enters service instance configuration mode.
Step 7	encapsulation dot1q <i>vlan-id</i> Example: Device(config-if-srv)# encapsulation dot1q 200	Defines the matching criteria to map 802.1Q frames ingress on an interface to the appropriate service instance. <ul style="list-style-type: none"> • Ensure that the interface on the adjoining customer edge (CE) device is on the same VLAN as this provider edge (PE) device.
Step 8	exit Example: Device(config-if-srv)# exit	Exits service instance configuration mode and returns to interface configuration mode.
Step 9	exit Example: Device(config-if)# exit	Exits interface configuration mode and returns to global configuration mode.
Step 10	bridge-domain <i>bd-id</i> Example:	Specifies the bridge domain ID and enters bridge-domain configuration mode.

	Command or Action	Purpose
	Device(config)# bridge-domain 100	
Step 11	member <i>interface-type-number</i> service-instance <i>service-id</i> [split-horizon group <i>group-id</i>] Example: Device(config-bdomain)# member gigabitethernet0/0/1 service-instance 1000	Binds a service instance to a bridge domain instance.
Step 12	end Example: Device(config-bdomain)# end	Exits bridge-domain configuration mode and returns to privileged EXEC mode.

Configuring Access Ports for Untagged Traffic from a CE Device

Procedure

	Command or Action	Purpose
Step 1	enable Example: Device> enable	Enables privileged EXEC mode. <ul style="list-style-type: none"> • Enter your password if prompted.
Step 2	configure terminal Example: Device# configure terminal	Enters global configuration mode.
Step 3	interface <i>type number</i> Example: Device(config)# interface gigabitethernet 0/0/0	Specifies an interface and enters interface configuration mode.
Step 4	no ip address [<i>ip-address mask</i>] [secondary] Example: Device(config-if)# no ip address	Disables IP processing.
Step 5	negotiation auto Example: Device(config-if)# negotiation auto	Enables the autonegotiation protocol to configure the speed, duplex, and automatic flow control of the Gigabit Ethernet interface.

	Command or Action	Purpose
Step 6	service instance <i>si-id</i> ethernet Example: <pre>Device(config-if)# service instance 10 ethernet</pre>	Specifies a service instance ID and enters service instance configuration mode.
Step 7	encapsulation untagged Example: <pre>Device(config-if-srv)# encapsulation untagged</pre>	Defines the matching criteria to map untagged ingress Ethernet frames on an interface to the appropriate service instance. <ul style="list-style-type: none"> • Ensure that the interface on the adjoining customer edge (CE) device is on the same VLAN as this provider edge (PE) device.
Step 8	bridge-domain <i>bd-id</i> Example: <pre>Device(config-if-srv)# bridge-domain 100</pre>	Binds a service instance or MAC tunnel to a bridge domain instance.
Step 9	end Example: <pre>Device(config-if-srv)# end</pre>	Exits service instance configuration mode and returns to privileged EXEC mode.

Configuring Access Ports for Untagged Traffic from a CE Device: Alternate Configuration

Procedure

	Command or Action	Purpose
Step 1	enable Example: <pre>Device> enable</pre>	Enables privileged EXEC mode. <ul style="list-style-type: none"> • Enter your password if prompted.
Step 2	configure terminal Example: <pre>Device# configure terminal</pre>	Enters global configuration mode.
Step 3	interface <i>type number</i> Example: <pre>Device(config)# interface gigabitethernet 0/4/4</pre>	Specifies an interface and enters interface configuration mode.

	Command or Action	Purpose
Step 4	no ip address [<i>ip-address mask</i>] [secondary] Example: Device(config-if)# no ip address	Disables IP processing.
Step 5	negotiation auto Example: Device(config-if)# negotiation auto	Enables the autonegotiation protocol to configure the speed, duplex, and automatic flow control of the Gigabit Ethernet interface.
Step 6	service instance <i>si-id</i> ethernet Example: Device(config-if)# service instance 10 ethernet	Specifies a service instance ID and enters service instance configuration mode.
Step 7	encapsulation untagged Example: Device(config-if-srv)# encapsulation untagged	Defines the matching criteria to map untagged ingress Ethernet frames on an interface to the appropriate service instance. <ul style="list-style-type: none"> • Ensure that the interface on the adjoining customer edge (CE) device is on the same VLAN as this provider edge (PE) device.
Step 8	exit Example: Device(config-if-srv)# exit	Exits service instance configuration mode and returns to interface configuration mode.
Step 9	exit Example: Device(config-if)# exit	Exits interface configuration mode and returns to global configuration mode.
Step 10	bridge-domain <i>bd-id</i> Example: Device(config)# bridge-domain 100	Specifies the bridge domain ID and enters bridge-domain configuration mode.
Step 11	member <i>interface-type-number</i> service-instance <i>service-id</i> [split-horizon group <i>group-id</i>] Example: Device(config-bdomain)# member gigabitethernet0/4/4 service-instance 1000	Binds a service instance to a bridge domain instance.

	Command or Action	Purpose
Step 12	end Example: Device(config-bdomain)# end	Exits bridge-domain configuration mode and returns to privileged EXEC mode.

Configuring Q-in-Q EFP



Note When a thread-local storage (TLS) is configured, the provider edge (PE) device forwards all Ethernet packets received from the customer edge (CE) device to all local Ethernet interfaces and emulated virtual circuits (VCs) that belong to the same Virtual Private LAN Services (VPLS) domain if the MAC address is not found in the Layer 2 forwarding table.

Procedure

	Command or Action	Purpose
Step 1	enable Example: Device> enable	Enables privileged EXEC mode. <ul style="list-style-type: none"> • Enter your password if prompted.
Step 2	configure terminal Example: Device# configure terminal	Enters global configuration mode.
Step 3	interface <i>type number</i> Example: Device(config)# interface gigabitethernet 0/0/2	Specifies an interface and enters interface configuration mode.
Step 4	no ip address [<i>ip-address mask</i>] [<i>secondary</i>] Example: Device(config-if)# no ip address	Disables IP processing.
Step 5	negotiation auto Example: Device(config-if)# negotiation auto	Enables the autonegotiation protocol to configure the speed, duplex, and automatic flow control of the Gigabit Ethernet interface.
Step 6	service instance <i>si-id</i> ethernet Example:	Specifies a service instance ID and enters service instance configuration mode.

	Command or Action	Purpose
	<code>Device(config-if)# service instance 10 ethernet</code>	
Step 7	encapsulation dot1q <i>vlan-id</i> second-dot1q <i>vlan-id</i> Example: <code>Device(config-if-srv)# encapsulation dot1q 200 second-dot1q 400</code>	Defines the matching criteria to map Q-in-Q ingress frames on an interface to the appropriate service instance. <ul style="list-style-type: none"> • Ensure that the interface on the adjoining CE device is on the same VLAN as this PE device.
Step 8	bridge-domain <i>bd-id</i> Example: <code>Device(config-if-srv)# bridge-domain 100</code>	Binds a service instance or a MAC tunnel to a bridge domain instance.
Step 9	end Example: <code>Device(config-if-srv)# end</code>	Exits service instance configuration mode and returns to privileged EXEC mode.

Configuring Q-in-Q EFP: Alternate Configuration



Note When a thread-local storage (TLS) is configured, the provider edge (PE) device forwards all Ethernet packets received from the customer edge (CE) device to all local Ethernet interfaces and emulated virtual circuits (VCs) belonging to the same Virtual Private LAN Services (VPLS) domain if the MAC address is not found in the Layer 2 forwarding table.

Procedure

	Command or Action	Purpose
Step 1	enable Example: <code>Device> enable</code>	Enables privileged EXEC mode. <ul style="list-style-type: none"> • Enter your password if prompted.
Step 2	configure terminal Example: <code>Device# configure terminal</code>	Enters global configuration mode.
Step 3	interface <i>type number</i> Example:	Specifies an interface and enters interface configuration mode.

	Command or Action	Purpose
	Device(config)# interface gigabitethernet 0/0/2	
Step 4	no ip address [<i>ip-address mask</i>] [secondary] Example: Device(config-if)# no ip address	Disables IP processing.
Step 5	negotiation auto Example: Device(config-if)# negotiation auto	Enables the autonegotiation protocol to configure the speed, duplex, and automatic flow control of the Gigabit Ethernet interface.
Step 6	service instance <i>si-id</i> ethernet Example: Device(config-if)# service instance 10 ethernet	Specifies a service instance ID and enters service instance configuration mode.
Step 7	encapsulation dot1q <i>vlan-id</i> second-dot1q <i>vlan-id</i> Example: Device(config-if-srv)# encapsulation dot1q 200 second-dot1q 400	Defines the matching criteria to map Q-in-Q ingress frames on an interface to the appropriate service instance. <ul style="list-style-type: none"> • Ensure that the interface on the adjoining CE device is on the same VLAN as this PE device.
Step 8	exit Example: Device(config-if-srv)# exit	Exits service instance configuration mode and returns to interface configuration mode.
Step 9	exit Example: Device(config-if)# exit	Exits interface configuration mode and returns to global configuration mode.
Step 10	bridge-domain <i>bd-id</i> Example: Device(config)# bridge-domain 100	Specifies the bridge domain ID and enters bridge-domain configuration mode.
Step 11	member <i>interface-type-number</i> service-instance <i>service-id</i> [split-horizon group <i>group-id</i>] Example: Device(config-bdomain)# member	Binds a service instance to a bridge domain instance.

	Command or Action	Purpose
	<code>gigabitethernet0/0/2 service-instance 1000</code>	
Step 12	end Example: <code>Device(config-bdomain)# end</code>	Exits bridge-domain configuration mode and returns to privileged EXEC mode.

Configuring MPLS on a PE Device

To configure Multiprotocol Label Switching (MPLS) on a provider edge (PE) device, configure the required MPLS parameters.



Note Before configuring MPLS, ensure that IP connectivity exists between all PE devices by configuring Interior Gateway Protocol (IGP), Open Shortest Path First (OSPF), or Intermediate System to Intermediate System (IS-IS) between PE devices.

Procedure

	Command or Action	Purpose
Step 1	enable Example: <code>Device> enable</code>	Enables privileged EXEC mode. <ul style="list-style-type: none"> • Enter your password if prompted.
Step 2	configure terminal Example: <code>Device# configure terminal</code>	Enters global configuration mode.
Step 3	mpls label protocol {ldp tdp} Example: <code>Device(config)# mpls label protocol ldp</code>	Specifies the label distribution protocol for the platform.
Step 4	mpls ldp logging neighbor-changes Example: <code>Device(config)# mpls ldp logging neighbor-changes</code>	(Optional) Generates system error logging (syslog) messages when LDP sessions go down.
Step 5	mpls ldp discovery hello holdtime seconds Example:	Configures the interval between the transmission of consecutive LDP discovery hello messages or the hold time for an LDP transport connection.

	Command or Action	Purpose
	Device(config)# mpls ldp discovery hello holdtime 5	
Step 6	mpls ldp router-id <i>interface-type-number</i> [force] Example: Device(config)# mpls ldp router-id loopback0 force	Specifies a preferred interface for the LDP router ID.
Step 7	end Example: Device(config)# end	Exits global configuration mode and returns to privileged EXEC mode.

Configuring a VFI on a PE Device

The virtual forwarding interface (VFI) specifies the VPN ID of a Virtual Private LAN Services (VPLS) domain, the addresses of other provider edge (PE) devices in the domain, and the type of tunnel signaling and encapsulation mechanism for each peer. Perform this task to configure a VFI:



Note Only Multiprotocol Label Switching (MPLS) encapsulation is supported.



Note You must configure BDI on the bridge domain that has the association with the VFI.

Procedure

	Command or Action	Purpose
Step 1	enable Example: Device> enable	Enables privileged EXEC mode. <ul style="list-style-type: none"> • Enter your password if prompted.
Step 2	configure terminal Example: Device# configure terminal	Enters global configuration mode.
Step 3	l2 vfi name manual Example: Device(config)# l2 vfi vfi110 manual	Establishes a Layer 2 VPN (L2VPN) virtual forwarding interface (VFI) between two or more separate networks and enters VFI configuration mode.

	Command or Action	Purpose
Step 4	vpn id <i>vpn-id</i> Example: Device(config-vfi)# vpn id 110	Configures a VPN ID for a VPLS domain. <ul style="list-style-type: none"> The emulated VCs bound to this Layer 2 virtual routing and forwarding (VRF) instance use this VPN ID for signaling.
Step 5	neighbor <i>remote-router-id vc-id</i> { encapsulation <i>encapsulation-type</i> pw-class <i>pw-name</i> } [no-split-horizon] Example: Device(config-vfi)# neighbor 172.16.10.2 4 encapsulation mpls	Specifies the type of tunnel signaling and encapsulation mechanism for each VPLS peer. <p>Note Split horizon is the default configuration to avoid broadcast packet looping and to isolate Layer 2 traffic. Use the no-split-horizon keyword to disable split horizon and to configure multiple VCs per spoke into the same VFI.</p>
Step 6	bridge-domain <i>bd-id</i> Example: Device(config-vfi)# bridge-domain 100	Specifies a bridge domain.
Step 7	end Example: Device(config-vfi)# end	Exits VFI configuration mode and returns to privileged EXEC mode.

Configuring a VFI on a PE Device: Alternate Configuration

Procedure

	Command or Action	Purpose
Step 1	enable Example: Device> enable	Enables privileged EXEC mode. <ul style="list-style-type: none"> Enter your password if prompted.
Step 2	configure terminal Example: Device# configure terminal	Enters global configuration mode.

	Command or Action	Purpose
Step 3	l2vpn vfi context <i>name</i> Example: Device(config)# l2vpn vfi context vfi110	Establishes a L2VPN VFI between two or more separate networks, and enters VFI configuration mode.
Step 4	vpn id <i>id</i> Example: Device(config-vfi)# vpn id 110	Configures a VPN ID for a Virtual Private LAN Services (VPLS) domain. The emulated virtual circuits (VCs) bound to this Layer 2 virtual routing and forwarding (VRF) instance use this VPN ID for signaling.
Step 5	member <i>ip-address</i> [<i>vc-id</i>] encapsulation mpls Example: Device(config-vfi)# member 172.16.10.2 4 encapsulation mpls	Specifies the devices that form a point-to-point Layer 2 VPN (L2VPN) virtual forwarding interface (VFI) connection and Multiprotocol Label Switching (MPLS) as the encapsulation type.
Step 6	exit Example: Device(config-vfi)# exit	Exits VFI configuration mode and returns to global configuration mode.
Step 7	bridge-domain <i>bd-id</i> Example: Device(config)# bridge-domain 100	Specifies a bridge domain and enters bridge-domain configuration mode.
Step 8	member vfi <i>vfi-name</i> Example: Device(config-bdomain)# member vfi vfi110	Binds a VFI instance to a bridge domain instance.
Step 9	end Example: Device(config-bdomain)# end	Exits bridge-domain configuration mode and returns to privileged EXEC mode.

Configuring Static Virtual Private LAN Services

To configure static Virtual Private LAN Services (VPLS), perform the following tasks:

- Configuring a Pseudowire for Static VPLS
- Configuring VFI for Static VPLS
- Configuring a VFI for Static VPLS: Alternate Configuration
- Configuring an Attachment Circuit for Static VPLS

- Configuring an Attachment Circuit for Static VPLS: Alternate Configuration
- Configuring an MPLS-TP Tunnel for Static VPLS with TP
- Configuring a VFI for Static VPLS: Alternate Configuration

Configuring a Pseudowire for Static VPLS

The configuration of pseudowires between provider edge (PE) devices helps in the successful transmission of the Layer 2 frames between PE devices.

Use the pseudowire template to configure the virtual circuit (VC) type for the virtual path identifier (VPI) pseudowire. In the following task, the pseudowire will go through a Multiprotocol Label Switching (MPLS)-Tunneling Protocol (TP) tunnel.

The pseudowire template configuration specifies the characteristics of the tunneling mechanism that is used by the pseudowires, which are:

- Encapsulation type
- Control protocol
- Payload-specific options
- Preferred path

Perform this task to configure a pseudowire template for static Virtual Private LAN Services (VPLS).



Note Ensure that you perform this task before configuring the virtual forwarding instance (VFI) peer. If the VFI peer is configured before the pseudowire class, the configuration is incomplete until the pseudowire class is configured. The **show running-config** command displays an error stating that configuration is incomplete.

```
Device# show running-config | sec vfi

12 vfi config manual
   vpn id 1000
   ! Incomplete point-to-multipoint vfi config
```

Procedure

	Command or Action	Purpose
Step 1	enable Example: Device> enable	Enables privileged EXEC mode. <ul style="list-style-type: none"> • Enter your password if prompted.
Step 2	configure terminal Example: Device# configure terminal	Enters global configuration mode.

	Command or Action	Purpose
Step 3	template type pseudowire <i>name</i> Example: <pre>Device(config)# template type pseudowire static-vpls</pre>	Specifies the template type as pseudowire and enters template configuration mode.
Step 4	encapsulation mpls Example: <pre>Device(config-template)# encapsulation mpls</pre>	Specifies the tunneling encapsulation. <ul style="list-style-type: none"> For Any Transport over MPLS (AToM), the encapsulation type is MPLS.
Step 5	signaling protocol none Example: <pre>Device(config-template)# signaling protocol none</pre>	Specifies that no signaling protocol is configured for the pseudowire class.
Step 6	preferred-path interface Tunnel-tp <i>interface-number</i> Example: <pre>Device(config-template)# preferred-path interface Tunnel-tp 1</pre>	(Optional) Specifies the path that traffic uses: an MPLS Traffic Engineering (TE) tunnel or destination IP address and Domain Name Server (DNS) name.
Step 7	exit Example: <pre>Device(config-template)# exit</pre>	Exits template configuration mode and returns to global configuration mode.
Step 8	interface pseudowire <i>number</i> Example: <pre>Device(config)# interface pseudowire 1</pre>	Establishes a pseudowire interface and enters interface configuration mode.
Step 9	source template type pseudowire <i>name</i> Example: <pre>Device(config-if)# source template type pseudowire static-vpls</pre>	Configures the source template type of the configured pseudowire.
Step 10	neighbor <i>peer-address</i> <i>vcid-value</i> Example: <pre>Device(config-if)# neighbor 10.0.0.1 123</pre>	Specifies the peer IP address and VC ID value of a Layer 2 VPN (L2VPN) pseudowire.

	Command or Action	Purpose
Step 11	label <i>local-pseudowire-label</i> <i>remote-pseudowire-label</i> Example: Device(config-if)# label 301 17	Configures an Any Transport over MPLS (AToM) static pseudowire connection by defining local and remote circuit labels.
Step 12	end Example: Device(config-if)# end	Exits interface configuration mode and returns to privileged EXEC mode.

Configuring VFI for Static VPLS



Note Ensure that you perform this task after configuring the pseudowire. If the VFI peer is configured before the pseudowire, the configuration is incomplete until the pseudowire is configured. The output of the **show running-config** command displays an error stating that configuration is incomplete.

```
Device# show running-config | sec vfi

12 vfi config manual
   vpn id 1000
   ! Incomplete point-to-multipoint vfi config
```

Procedure

	Command or Action	Purpose
Step 1	enable Example: Device> enable	Enables privileged EXEC mode. <ul style="list-style-type: none"> • Enter your password if prompted.
Step 2	configure terminal Example: Device# configure terminal	Enters global configuration mode.
Step 3	mpls label range <i>minimum-value</i> <i>maximum-value</i> [static <i>minimum-static-value</i> <i>maximum-static-value</i>] Example: Device(config)# mpls label range 16 200 static 300 500	Configures the range of local labels available for use with Multiprotocol Label Switching (MPLS) applications on packet interfaces.

	Command or Action	Purpose
Step 4	pseudowire-class [<i>pw-class-name</i>] Example: Device(config)# pseudowire-class static_vpls	Specifies the name of a Layer 2 pseudowire class and enters pseudowire class configuration mode.
Step 5	encapsulation mpls Example: Device(config-pw-class)# encapsulation mpls	Specifies the tunneling encapsulation as MPLS.
Step 6	protocol { <i>l2tpv2</i> <i>l2tpv3</i> <i>none</i> } [<i>l2tp-class-name</i>] Example: Device(config-pw-class)# protocol none	Specifies that no signaling protocol will be used in Layer 2 Tunneling Protocol Version 3 (L2TPv3) sessions.
Step 7	exit Example: Device(config-pw-class)# exit	Exits pseudowire class configuration mode and returns to global configuration mode.
Step 8	l2 vfi <i>vfi-name</i> manual Example: Device(config)# l2 vfi static-vfi manual	Establishes a Layer 2 VPN (L2VPN) virtual forwarding interface (VFI) between two or more separate networks, and enters Layer 2 VFI manual configuration mode.
Step 9	vpn id <i>vpn-id</i> Example: Device(config-vfi)# vpn id 100	Specifies the VPN ID.
Step 10	neighbor <i>ip-address</i> pw-class <i>pw-name</i> Example: Device(config-vfi)# neighbor 10.3.4.4 pw-class static_vpls	Specifies the IP address of the peer and the pseudowire class.
Step 11	mpls label <i>local-pseudowire-label</i> <i>remote-pseudowire-label</i> Example: Device(config-vfi)# mpls label 301 17	Configures an Any Transport over MPLS (AToM) static pseudowire connection by defining local and remote circuit labels.
Step 12	mpls control-word Example:	(Optional) Enables the MPLS control word in an AToM static pseudowire connection.

	Command or Action	Purpose
	<code>Device(config-vfi)# mpls control-word</code>	
Step 13	neighbor <i>ip-address</i> pw-class <i>pw-name</i> Example: <code>Device(config-vfi)# neighbor 2.3.4.3 pw-class static_vpls</code>	Specifies the IP address of the peer and the pseudowire class.
Step 14	mpls label <i>local-pseudowire-label</i> <i>remote-pseudowire-label</i> Example: <code>Device(config-vfi)# mpls label 302 18</code>	Configures an AToM static pseudowire connection by defining local and remote circuit labels.
Step 15	mpls control-word Example: <code>Device(config-vfi)# mpls control-word</code>	(Optional) Enables the MPLS control word in an AToM static pseudowire connection.
Step 16	end Example: <code>Device(config-vfi)# end</code>	Exits Layer 2 VFI manual configuration mode and returns to privileged EXEC mode.

Configuring a VFI for Static VPLS: Alternate Configuration



Note Ensure that you perform this task after configuring the pseudowire. If the VFI peer is configured before the pseudowire, the configuration is incomplete until the pseudowire is configured. The output of the **show running-config** command displays an error stating that configuration is incomplete.

```
Device# show running-config | sec vfi

12 vfi config manual
vpn id 1000
! Incomplete point-to-multipoint vfi config
```

Procedure

	Command or Action	Purpose
Step 1	enable Example: <code>Device> enable</code>	Enables privileged EXEC mode. <ul style="list-style-type: none"> • Enter your password if prompted.

	Command or Action	Purpose
Step 2	configure terminal Example: Device# configure terminal	Enters global configuration mode.
Step 3	l2vpn vfi context <i>vfi-name</i> Example: Device(config)# l2vpn vfi context vpls1	Establishes a Layer 2 VPN (L2VPN) virtual forwarding interface (VFI) between two or more separate networks and enters VFI configuration mode.
Step 4	vpn id <i>vpn-id</i> Example: Device(config-vfi)# vpn id 100	Specifies the VPN ID.
Step 5	exit Example: Device(config-vfi)# exit	Exits VFI configuration mode and returns to global configuration mode.
Step 6	interface <i>type number</i> Example: Device(config)# interface pseudowire 100	Specifies an interface and enters interface configuration mode.
Step 7	encapsulation mpls Example: Device(config-if)# encapsulation mpls	Specifies an encapsulation type for tunneling Layer 2 traffic over a pseudowire.
Step 8	neighbor <i>ip-address vc-id</i> Example: Device(config-if)# neighbor 10.3.4.4 100	Specifies the peer IP address and virtual circuit (VC) ID value of a Layer 2 VPN (L2VPN) pseudowire.
Step 9	label <i>local-pseudowire-label remote-pseudowire-label</i> Example: Device(config-if)# label 301 17	Configures an Any Transport over MPLS (AToM) static pseudowire connection by defining local and remote circuit labels.
Step 10	control-word {include exclude} Example: Device(config-if)# control-word include	(Optional) Enables the Multiprotocol Label Switching (MPLS) control word in an AToM dynamic pseudowire connection.

	Command or Action	Purpose
Step 11	exit Example: Device(config-if)# exit	Exits interface configuration mode and returns to global configuration mode.
Step 12	bridge-domain <i>bd-id</i> Example: Device(config)# bridge-domain 24	Specifies the bridge domain ID and enters bridge-domain configuration mode.
Step 13	member vfi <i>vfi-name</i> Example: Device(config-bdomain)# member vfi vpls1	Binds a service instance to a bridge domain instance.
Step 14	end Example: Device(config-bdomain)# end	Exits bridge-domain configuration mode and returns to privileged EXEC mode.

Configuring an Attachment Circuit for Static VPLS

Procedure

	Command or Action	Purpose
Step 1	enable Example: Device> enable	Enables privileged EXEC mode. <ul style="list-style-type: none"> • Enter your password if prompted.
Step 2	configure terminal Example: Device# configure terminal	Enters global configuration mode.
Step 3	interface gigabitethernet <i>slot/interface</i> Example: Device(config)# interface gigabitethernet 0/0/1	Specifies an interface and enters interface configuration mode. <ul style="list-style-type: none"> • Ensure that the interfaces between the customer edge (CE) and provider edge (PE) devices that run Ethernet over MPLS (EoMPLS) are in the same subnet. All other interfaces and backbone devices do not need to be in the same subnet.

	Command or Action	Purpose
Step 4	service instance <i>si-id</i> ethernet Example: <pre>Device(config-if)# service instance 100 ethernet</pre>	Configures an Ethernet service instance on an interface and enters service instance configuration mode.
Step 5	encapsulation dot1q <i>vlan-id</i> Example: <pre>Device(config-if-srv)# encapsulation dot1q 200</pre>	Defines the matching criteria to map 802.1Q frames ingress on an interface to the appropriate service instance. <ul style="list-style-type: none"> • Ensure that the interface on the adjoining CE device is on the same VLAN as this PE device.
Step 6	rewrite ingress tag pop <i>number</i> [symmetric] Example: <pre>Device(config-if-srv)# rewrite ingress tag pop 1 symmetric</pre>	(Optional) Specifies the encapsulation adjustment to be performed on a frame ingressing a service instance and the tag to be removed from a packet.
Step 7	bridge-domain <i>bd-id</i> Example: <pre>Device(config-if-srv)# bridge-domain 24</pre>	(Optional) Binds a service instance or a MAC tunnel to a bridge domain instance.
Step 8	end Example: <pre>Device(config-if-srv)# end</pre>	Exits service instance configuration mode and returns to privileged EXEC mode.

Configuring an Attachment Circuit for Static VPLS: Alternate Configuration

Procedure

	Command or Action	Purpose
Step 1	enable Example: <pre>Device> enable</pre>	Enables privileged EXEC mode. <ul style="list-style-type: none"> • Enter your password if prompted.
Step 2	configure terminal Example: <pre>Device# configure terminal</pre>	Enters global configuration mode.

	Command or Action	Purpose
Step 3	interface gigabitethernet <i>slot/interface</i> Example: <pre>Device(config)# interface gigabitethernet 0/0/1</pre>	Specifies an interface and enters interface configuration mode. <ul style="list-style-type: none"> • Ensure that the interfaces between the customer edge (CE) and provider edge (PE) devices that are running Ethernet over MPLS (EoMPLS) are in the same subnet. All other interfaces and backbone devices do not need to be in the same subnet.
Step 4	service instance <i>si-id</i> ethernet Example: <pre>Device(config-if)# service instance 10 ethernet</pre>	Specifies a service instance ID and enters service instance configuration mode.
Step 5	encapsulation dot1q <i>vlan-id</i> Example: <pre>Device(config-if-srv)# encapsulation dot1q 200</pre>	Defines the matching criteria to map 802.1Q frames ingress on an interface to the appropriate service instance. <ul style="list-style-type: none"> • Ensure that the interface on the adjoining CE device is on the same VLAN as this PE device.
Step 6	rewrite ingress tag pop <i>number</i> [symmetric] Example: <pre>Device(config-if-srv)# rewrite ingress tag pop 1 symmetric</pre>	(Optional) Specifies the encapsulation adjustment to be performed on a frame ingressing a service instance and the tag to be removed from a packet.
Step 7	exit Example: <pre>Device(config-if-srv)# exit</pre>	Exits service instance configuration mode and returns to interface configuration mode.
Step 8	exit Example: <pre>Device(config-if)# exit</pre>	Exits interface configuration mode and returns to global configuration mode.
Step 9	bridge-domain <i>bd-id</i> Example: <pre>Device(config)# bridge-domain 100</pre>	Specifies the bridge domain ID and enters bridge-domain configuration mode.
Step 10	member <i>interface-type-number</i> service-instance <i>service-id</i> [split-horizon group <i>group-id</i>]	(Optional) Binds a service instance to a bridge domain instance.

	Command or Action	Purpose
	Example: Device(config-bdomain)# member gigabitethernet0/0/1 service-instance 1000	
Step 11	end Example: Device(config-bdomain)# end	Exits bridge-domain configuration mode and returns to privileged EXEC mode.

Configuring an MPLS-TP Tunnel for Static VPLS with TP

Procedure

	Command or Action	Purpose
Step 1	enable Example: Device> enable	Enables privileged EXEC mode. <ul style="list-style-type: none"> • Enter your password if prompted.
Step 2	configure terminal Example: Device# configure terminal	Enters global configuration mode.
Step 3	interface Tunnel-tp number Example: Device(config)# interface Tunnel-tp 4	Configures a Multiprotocol Label Switching (MPLS) transport profile tunnel and enters interface configuration mode. <ul style="list-style-type: none"> • Use the same interface as you configured for the pseudowire class.
Step 4	no ip address Example: Device(config-if)# no ip address	Disables the IP address configuration.
Step 5	no keepalive Example: Device(config-if)# no keepalive	Disables the keepalive configuration.
Step 6	tp destination ip-address Example: Device(config-if)# tp destination 10.22.22.22	Configures the tunnel destination.

	Command or Action	Purpose
Step 7	bfd <i>bfd-template</i> Example: Device(config-if)# bfd tp	Binds a single-hop Bidirectional Forwarding Detection (BFD) template to an interface.
Step 8	working-lsp Example: Device(config-if)# working-lsp	Configures the working label switched path (LSP) and enters working interface configuration mode.
Step 9	out-label <i>number</i> out-link <i>number</i> Example: Device(config-if-working)# out-label 16 out-link 100	Configures the out link and out label for the working LSP.
Step 10	lsp-number <i>number</i> Example: Device(config-if-working)# lsp-number 0	Configures the ID number for the working LSP.
Step 11	exit Example: Device(config-if-working)# exit	Exits working interface configuration mode and returns to interface configuration mode.
Step 12	protect-lsp Example: Device(config-if)# protect-lsp	Enters protection configuration mode for the label switched path (LSP) and enters protect interface configuration mode.
Step 13	out-label <i>number</i> out-link <i>number</i> Example: Device(config-if-protect)# out-label 11 out-link 500	Configures the out link and out label for the protect LSP.
Step 14	in-label <i>number</i> Example: Device(config-if-protect)# in-label 600	Configures the in label for the protect LSP.
Step 15	lsp-number <i>number</i> Example: Device(config-if-protect)# lsp-number 1	Configures the ID number for the working protect LSP.

	Command or Action	Purpose
Step 16	exit Example: Device(config-if-protect)# exit	Exits protect interface configuration mode and returns to interface configuration mode.
Step 17	exit Example: Device(config-if)# exit	Exits interface configuration mode and returns to global configuration mode.
Step 18	interface type number Example: Device(config-if)# interface GigabitEthernet 0/1/0	Configures a interface and enters interface configuration mode.
Step 19	ip address ip-address ip-mask Example: Device(config)# ip address 10.0.0.1 255.255.255.0	(Optional) Configures the IP address and mask if not using an IP-less core.
Step 20	mpls tp link link-num {ipv4 ip-address tx-mac mac-address} rx-mac mac-address Example: Device(config-if)# mpls tp link 10 tx-mac 0100.0c99.8877 rx-mac 0100.0c99.8877	Configures Multiprotocol Label Switching (MPLS) transport profile (TP) link parameters.
Step 21	end Example: Device(config-if)# end	Exits interface configuration mode and returns to privileged EXEC mode.

Configuring a VFI for Static VPLS: Alternate Configuration



Note Ensure that you perform this task after configuring the pseudowire. If the VFI peer is configured before the pseudowire, the configuration is incomplete until the pseudowire is configured. The output of the **show running-config** command displays an error stating that configuration is incomplete.

```
Device# show running-config | sec vfi
```

```
12 vfi config manual
   vpn id 1000
   ! Incomplete point-to-multipoint vfi config
```

Procedure

	Command or Action	Purpose
Step 1	enable Example: Device> enable	Enables privileged EXEC mode. <ul style="list-style-type: none"> • Enter your password if prompted.
Step 2	configure terminal Example: Device# configure terminal	Enters global configuration mode.
Step 3	l2vpn vfi context <i>vfi-name</i> Example: Device(config)# l2vpn vfi context vpls1	Establishes a Layer 2 VPN (L2VPN) virtual forwarding interface (VFI) between two or more separate networks and enters VFI configuration mode.
Step 4	vpn id <i>vpn-id</i> Example: Device(config-vfi)# vpn id 100	Specifies the VPN ID.
Step 5	exit Example: Device(config-vfi)# exit	Exits VFI configuration mode and returns to global configuration mode.
Step 6	interface <i>type number</i> Example: Device(config)# interface pseudowire 100	Specifies an interface and enters interface configuration mode.
Step 7	encapsulation mpls Example: Device(config-if)# encapsulation mpls	Specifies an encapsulation type for tunneling Layer 2 traffic over a pseudowire.
Step 8	neighbor <i>ip-address vc-id</i> Example: Device(config-if)# neighbor 10.3.4.4 100	Specifies the peer IP address and virtual circuit (VC) ID value of a Layer 2 VPN (L2VPN) pseudowire.
Step 9	label <i>local-pseudowire-label remote-pseudowire-label</i> Example:	Configures an Any Transport over MPLS (AToM) static pseudowire connection by defining local and remote circuit labels.

	Command or Action	Purpose
	Device(config-if)# label 301 17	
Step 10	control-word {include exclude} Example: Device(config-if)# control-word include	(Optional) Enables the Multiprotocol Label Switching (MPLS) control word in an AToM dynamic pseudowire connection.
Step 11	exit Example: Device(config-if)# exit	Exits interface configuration mode and returns to global configuration mode.
Step 12	bridge-domain <i>bd-id</i> Example: Device(config)# bridge-domain 24	Specifies the bridge domain ID and enters bridge-domain configuration mode.
Step 13	member vfi <i>vfi-name</i> Example: Device(config-bdomain)# member vfi vpls1	Binds a service instance to a bridge domain instance.
Step 14	end Example: Device(config-bdomain)# end	Exits bridge-domain configuration mode and returns to privileged EXEC mode.

Configuration Examples for Virtual Private LAN Services

Example: Configuring 802.1Q Access Ports for Tagged Traffic from a CE Device

This example shows how to configure the tagged traffic:

```
Device(config)# interface GigabitEthernet 0/0/1
Device(config-if)# no ip address
Device(config-if)# negotiation auto
Device(config-if)# service instance 10 ethernet
Device(config-if-srv)# encapsulation dot1q 200
Device(config-if-srv)# bridge-domain 100
Device(config-if-srv)# end
```

Example: Configuring 802.1Q Access Ports for Tagged Traffic from a CE Device: Alternate Configuration

The following example shows how to configure the tagged traffic:

```
Device(config)# interface GigabitEthernet 0/0/1
Device(config-if)# no ip address
Device(config-if)# negotiation auto
Device(config-if)# service instance 10 ethernet
Device(config-if-srv)# encapsulation dot1q 200
Device(config-if-srv)# exit
Device(config-if)# exit
Device(config)# bridge-domain 100
Device(config-bd)# member gigabitethernet0/0/1 service-instance 1000
Device(config-bd)# end
```

Example: Configuring Access Ports for Untagged Traffic from a CE Device

The following example shows how to configure access ports for untagged traffic:

```
Device(config)# interface gigabitethernet 0/0/0
Device(config-if)# no ip address
Device(config-if)# negotiation auto
Device(config-if)# service instance 10 ethernet
Device(config-if-srv)# encapsulation untagged
Device(config-if-srv)# bridge-domain 100
Device(config-if-srv)# end
```

The following example shows a virtual forwarding interface (VFI) configuration:

```
Device(config)# 12 vfi VPLSA manual
Device(config-vfi)# vpn id 110
Device(config-vfi)# neighbor 10.11.11.11 encapsulation mpls
Device(config-vfi)# neighbor 10.33.33.33 encapsulation mpls
Device(config-vfi)# neighbor 10.44.44.44 encapsulation mpls
Device(config-vfi)# bridge-domain 110
Device(config-vfi)# end
```

The following example shows a VFI configuration for hub and spoke.

```
Device(config)# 12 vfi VPLSB manual
Device(config-vfi)# vpn id 111
Device(config-vfi)# neighbor 10.99.99.99 encapsulation mpls
Device(config-vfi)# neighbor 10.12.12.12 encapsulation mpls
Device(config-vfi)# neighbor 10.13.13.13 encapsulation mpls no-split-horizon
Device(config-vfi)# bridge-domain 111
Device(config-vfi)# end
```

The output of the **show mpls 12transport vc** command displays various information related to a provide edge (PE) device. The VC ID in the output represents the VPN ID; the VC is identified by the combination of the destination address and the VC ID as shown in the command output. The output of the **show mpls 12transport vc detail** command displays detailed information about virtual circuits (VCs) on a PE device.

Example: Configuring Access Ports for Untagged Traffic from a CE Device: Alternate Configuration

```
Device# show mpls l2transport vc 201
```

Local intf	Local circuit	Dest address	VC ID	Status
VFI VPLSA	VFI	10.11.11.11	110	UP
VFI VPLSA	VFI	10.33.33.33	110	UP
VFI VPLSA	VFI	10.44.44.44	110	UP

The following sample output from the **show vfi** command displays the VFI status:

```
Device# show vfi VPLSA
```

```
VFI name: VPLSA, state: up
Local attachment circuits:
  Vlan2
Neighbors connected via pseudowires:
Peer Address      VC ID      Split-horizon
10.11.11.11       110        Y
10.33.33.33       110        Y
10.44.44.44       110        Y
```

```
Device# show vfi VPLSB
```

```
VFI name: VPLSB, state: up
Local attachment circuits:
  Vlan2
Neighbors connected via pseudowires:
Peer Address      VC ID      Split-horizon
10.99.99.99       111        Y
10.12.12.12       111        Y
10.13.13.13       111        N
```

Example: Configuring Access Ports for Untagged Traffic from a CE Device: Alternate Configuration

The following example shows how to configure the untagged traffic.

```
Device(config)# interface GigabitEthernet 0/4/4
Device(config-if)# no ip address
Device(config-if)# negotiation auto
Device(config-if)# service instance 10 ethernet
Device(config-if-srv)# encapsulation untagged
Device(config-if-srv)# exit
Device(config-if)# exit
Device(config)# bridge-domain 100
Device(config-bdmain)# member GigabitEthernet0/4/4 service-instance 10
Device(config-if-srv)# end
```

Example: Configuring Q-in-Q EFP

The following example shows how to configure the tagged traffic.

```

Device(config)# interface GigabitEthernet 0/0/2
Device(config-if)# no ip address
Device(config-if)# negotiate auto
Device(config-if)# service instance 10 ethernet
Device(config-if-srv)# encapsulation dot1q 200 second-dot1q 400
Device(config-if-srv)# bridge-domain 100
Device(config-if-srv)# end

```

Use the **show spanning-tree vlan** command to verify that the ports are not in a blocked state. Use the **show vlan id** command to verify that a specific port is configured to send and receive specific VLAN traffic.

Example: Configuring Q-in-Q in EFP: Alternate Configuration

The following example shows how to configure the tagged traffic:

```

Device(config)# interface GigabitEthernet 0/4/4
Device(config-if)# no ip address
Device(config-if)# nonegotiate auto
Device(config-if)# service instance 10 ethernet
Device(config-if-srv)# encapsulation dot1q 200 second-dot1q 400
Device(config-if-srv)# exit
Device(config-if)# exit
Device(config)# bridge-domain 100
Device(config-bdmain)# member GigabitEthernet0/4/4 service-instance 1000
Device(config-bdmain)# end

```

Use the **show spanning-tree vlan** command to verify that the port is not in a blocked state. Use the **show vlan id** command to verify that a specific port is configured to send and receive a specific VLAN traffic.

Example: Configuring MPLS on a PE Device

The following example shows a global Multiprotocol Label Switching (MPLS) configuration:

```

Device(config)# mpls label protocol ldp
Device(config)# mpls ldp logging neighbor-changes
Device(config)# mpls ldp discovery hello holdtime 5
Device(config)# mpls ldp router-id Loopback0 force

```

The following sample output from the **show ip cef** command displays the Label Distribution Protocol (LDP) label assigned:

```

Device# show ip cef 192.168.17.7

192.168.17.7/32, version 272, epoch 0, cached adjacency to POS4/1
0 packets, 0 bytes
  tag information set
    local tag: 8149
    fast tag rewrite with PO4/1, point2point, tags imposed: {4017}
  via 10.3.1.4, POS4/1, 283 dependencies
  next hop 10.3.1.4, POS4/1
  valid cached adjacency
  tag rewrite with PO4/1, point2point, tags imposed: {4017}

```

Example: VFI on a PE Device

The following example shows a virtual forwarding instance (VFI) configuration:

```
Device(config)# 12 vfi vfi110 manual
Device(config-vfi)# vpn id 110
Device(config-vfi)# neighbor 172.16.10.2 4 encapsulation mpls
Device(config-vfi)# neighbor 10.16.33.33 encapsulation mpls
Device(config-vfi)# neighbor 198.51.100.44 encapsulation mpls
Device(config-vfi)# bridge-domain 100
Device(config-vfi)# end
```

The following example shows a VFI configuration for a hub-and-spoke configuration:

```
Device(config)# 12 vfi VPLSA manual
Device(config-vfi)# vpn id 110
Device(config-vfi)# neighbor 10.9.9.9 encapsulation mpls
Device(config-vfi)# neighbor 192.0.2.12 encapsulation mpls
Device(config-vfi)# neighbor 203.0.113.4 encapsulation mpls no-split-horizon
Device(config-vfi)# bridge-domain 100
Device(config-vfi)# end
```

The **show mpls 12transport vc** command displays information about the provider edge (PE) device. The **show mpls 12transport vc detail** command displays detailed information about the virtual circuits (VCs) on a PE device.

```
Device# show mpls 12transport vc 201
```

Local intf	Local circuit	Dest address	VC ID	Status
VFI test1	VFI	209.165.201.1	201	UP
VFI test1	VFI	209.165.201.2	201	UP
VFI test1	VFI	209.165.201.3	201	UP

The **show vfi vfi-name** command displays VFI status. The VC ID in the output represents the VPN ID; the VC is identified by the combination of the destination address and the VC ID as in the example below.

```
Device# show vfi VPLS-2
```

```
VFI name: VPLS-2, state: up
Local attachment circuits:
  Vlan2
Neighbors connected via pseudowires:
Peer Address      VC ID  Split-horizon
10.1.1.1          2      Y
10.1.1.2          2      Y
10.2.2.3          2      N
```

Example: VFI on a PE Device: Alternate Configuration

The following example shows how to configure a virtual forwarding interface (VFI) on a provider edge (PE) device:

```

Device(config)# l2vpn vfi context vfi110
Device(config-vfi)# vpn id 110
Device(config-vfi)# member 172.16.10.2 4 encapsulation mpls
Device(config-vfi)# member 10.33.33.33 encapsulation mpls
Device(config-vfi)# member 10.44.44.44 encapsulation mpls
Device(config-vfi)# exit
Device(config)# bridge-domain 100
Device(config-bdomain)# member vfi vfi110
Device(config-bdomain)# end

```

The following example shows how to configure a hub-and-spoke VFI configuration:

```

Device(config)# l2vpn vfi context VPLSA
Device(config-vfi)# vpn id 110
Device(config-vfi)# member 10.9.9.9 encapsulation mpls
Device(config-vfi)# member 172.16.10.2 4 encapsulation mpls
Device(config-vfi)# exit
Device(config)# bridge-domain 100
Device(config-bdomain)# member vfi VPLSA
Device(config-bdomain)# member GigabitEthernet0/0/0 service-instance 100
Device(config-bdomain)# member 10.33.33.33 10 encapsulation mpls
Device(config-bdomain)# end

```

The **show l2vpn atom vc** command displays information about the PE device. The command also displays information about Any Transport over MPLS (AToM) virtual circuits (VCs) and static pseudowires that are enabled to route Layer 2 packets on a device.

```

Device# show l2vpn atom vc

```

Local intf	Local circuit	Dest address	VC ID	Status
Eth0/0.1	Eth VLAN 101	10.0.0.2	101	UP
Eth0/0.1	Eth VLAN 101	10.0.0.3	201	DOWN

The **show l2vpn vfi** command displays the VFI status. The VC ID in the output represents the VPN ID; the VC is identified by the combination of the destination address and the VC ID as in the example below.

```

Device# show l2vpn vfi VPLS-2

```

Legend: RT= Route-target

```

VFI name: serviceCore1, State: UP, Signaling Protocol: LDP
VPN ID: 100, VPLS-ID: 9:10, Bridge-domain vlan: 100
RD: 9:10, RT: 10.10.10.10:150
Pseudo-port Interface: Virtual-Ethernet1000

```

Neighbors connected via pseudowires:

Interface	Peer Address	VC ID	Discovered Router ID	Next Hop
Pw2000	10.0.0.1	10	10.0.0.1	10.0.0.1
Pw2001	10.0.0.2	10	10.1.1.2	10.0.0.2
Pw2002	10.0.0.3	10	10.1.1.3	10.0.0.3
Pw5	10.0.0.4	10	-	10.0.0.4

Example: Full-Mesh VPLS Configuration

In a full-mesh configuration, each provider edge (PE) device creates a multipoint-to-multipoint forwarding relationship with all other PE devices in the Virtual Private LAN Services (VPLS) domain using a virtual forwarding interface (VFI). An Ethernet or a VLAN packet received from the customer network can be forwarded to one or more local interfaces and/or emulated virtual circuits (VCs) in the VPLS domain. To avoid a broadcast packet loop in the network, packets received from an emulated VC cannot be forwarded to any emulated VC in the VPLS domain on a PE device. Ensure that Layer 2 split horizon is enabled to avoid a broadcast packet loop in a full-mesh network.

Figure 7: Full-Mesh VPLS Configuration

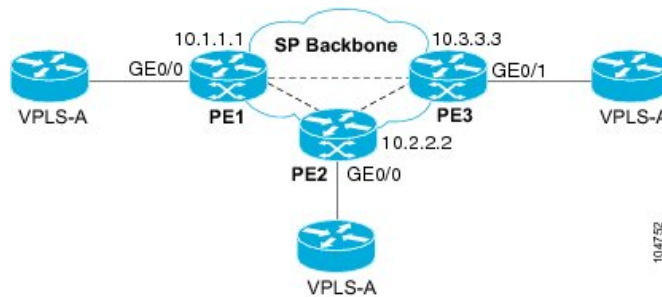

PE 1 Configuration

The following examples shows how to create virtual switch instances (VSIs) and associated VCs:

```
12 vfi PE1-VPLS-A manual
   vpn id 100
   neighbor 10.2.2.2 encapsulation mpls
   neighbor 10.3.3.3 encapsulation mpls
   bridge domain 100
!
interface Loopback 0
 ip address 10.1.1.1 255.255.0.0
```

The following example shows how to configure the customer edge (CE) device interface (there can be multiple Layer 2 interfaces in a VLAN):

```
interface GigabitEthernet 0/0/0
 no ip address
 negotiation auto
 service instance 10 ethernet
 encapsulation dot1q 200
 bridge-domain 100
```

PE 2 Configuration

The following example shows how to create VSIs and associated VCs.

```
12 vfi PE2-VPLS-A manual
   vpn id 100
   neighbor 10.1.1.1 encapsulation mpls
   neighbor 10.3.3.3 encapsulation mpls
   bridge domain 100
```

```
!
interface Loopback 0
 ip address 10.2.2.2 255.255.0.0
```

The following example shows how to configure the CE device interface (there can be multiple Layer 2 interfaces in a VLAN):

```
interface GigabitEthernet 0/0/0
 no ip address
 negotiation auto
 service instance 10 ethernet
 encapsulation dot1q 200
 bridge-domain 100
```

PE 3 Configuration

The following example shows how to create VSIs and associated VCs:

```
12 vfi PE3-VPLS-A manual
 vpn id 112
 neighbor 10.1.1.1 encapsulation mpls
 neighbor 10.2.2.2 encapsulation mpls
 bridge domain 100
!
interface Loopback 0
 ip address 10.3.3.3 255.255.0.0
```

The following example shows how to configure the CE device interface (there can be multiple Layer 2 interfaces in a VLAN).

```
interface GigabitEthernet 0/0/1
 no ip address
 negotiation auto
 service instance 10 ethernet
 encapsulation dot1q 200
 bridge-domain 100
!
```

The following sample output from the **show mpls 12 vc** command provides information about the status of the VC:

```
Device# show mpls 12 vc
```

Local intf	Local circuit	Dest address	VC ID	Status
VFI PE1-VPLS-A	VFI	10.2.2.2	100	UP
VFI PE1-VPLS-A	VFI	10.3.3.3	100	UP

The following sample output from the **show vfi** command provides information about the VFI:

```
Device# show vfi PE1-VPLS-A
```

```
VFI name: VPLSA, state: up
 Local attachment circuits:
  Vlan200
 Neighbors connected via pseudowires:
```

Example: Full-Mesh Configuration : Alternate Configuration

```
10.2.2.2 10.3.3.3
```

The following sample output from the **show mpls 12transport vc** command provides information about virtual circuits:

```
Device# show mpls 12transport vc detail

Local interface: VFI PE1-VPLS-A up
  Destination address: 10.2.2.2, VC ID: 100, VC status: up
  Tunnel label: imp-null, next hop point2point
  Output interface: Se2/0, imposed label stack {18}
  Create time: 3d15h, last status change time: 1d03h
  Signaling protocol: LDP, peer 10.2.2.2:0 up
  MPLS VC labels: local 18, remote 18
  Group ID: local 0, remote 0
  MTU: local 1500, remote 1500
  Remote interface description:
  Sequencing: receive disabled, send disabled
  VC statistics:
    packet totals: receive 0, send 0
    byte totals:   receive 0, send 0
    packet drops:  receive 0, send 0
```

Example: Full-Mesh Configuration : Alternate Configuration

In a full-mesh configuration, each provider edge (PE) router creates a multipoint-to-multipoint forwarding relationship with all other PE routers in the Virtual Private LAN Services (VPLS) domain using a virtual forwarding interface (VFI). An Ethernet or virtual LAN (VLAN) packet received from the customer network can be forwarded to one or more local interfaces and/or emulated virtual circuits (VCs) in the VPLS domain. To avoid broadcasted packets looping in the network, no packet received from an emulated VC can be forwarded to any emulated VC of the VPLS domain on a PE router. That is, Layer 2 split horizon should always be enabled as the default in a full-mesh network.

Figure 8: VPLS Configuration Example

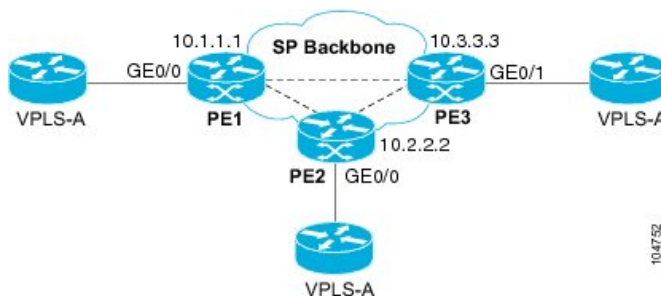

PE 1 Configuration

The following example shows how to create virtual switch instances (VSIs) and associated VCs and to configure the CE device interface (there can be multiple Layer 2 interfaces in a VLAN):

```
interface gigabitethernet 0/0/0
  service instance 100 ethernet
  encapsulation dot1q 100
  no shutdown
```

```

!
l2vpn vfi context PE1-VPLS-A
  vpn id 100
  neighbor 10.2.2.2 encapsulation mpls
  neighbor 10.3.3.3 encapsulation mpls
!
bridge-domain 100
  member gigabitethernet0/0/0 service-instance 100
  member vfi PE1-VPLS-A

```

PE 2 Configuration

The following example shows how to create VSIs and associated VCs and to configure the CE device interface (there can be multiple Layer 2 interfaces in a VLAN):

```

interface gigabitethernet 0/0/0
  service instance 100 ethernet
  encap dot1q 100
  no shutdown
!
l2vpn vfi context PE2-VPLS-A
  vpn id 100
  neighbor 10.1.1.1 encapsulation mpls
  neighbor 10.3.3.3 encapsulation mpls
!
bridge-domain 100
  member gigabitethernet0/0/0 service-instance 100
  member vfi PE2-VPLS-A

```

PE 3 Configuration

The following example shows how to create of the VSIs and associated VCs and to configure the CE device interface (there can be multiple Layer 2 interfaces in a VLAN):

```

interface gigabitethernet 0/0/0
  service instance 100 ethernet
  encap dot1q 100
  no shutdown
!
l2vpn vfi context PE3-VPLS-A
  vpn id 100
  neighbor 10.1.1.1 encapsulation mpls
  neighbor 10.2.2.2 encapsulation mpls
!
bridge-domain 100
  member gigabitethernet0/0/0 service-instance 100
  member vfi PE3-VPLS-A

```

The following sample output from the **show mpls l2 vc** command provides information on the status of the VC:

```
Device# show mpls l2 vc
```

Local intf	Local circuit	Dest address	VC ID	Status
VFI PE3-VPLS-A	VFI	10.2.2.2	100	UP

```
VFI PE3-VPLS-A VFI 10.3.3.3 100 UP
```

The following sample output from the **show l2vpn vfi** command provides information about the VFI:

```
Device# show l2vpn vfi VPLS-2

Legend: RT= Route-target

VFI name: serviceCore1, State: UP, Signaling Protocol: LDP
VPN ID: 100, VPLS-ID: 9:10, Bridge-domain vlan: 100
RD: 9:10, RT: 10.10.10.10:150
Pseudo-port Interface: Virtual-Ethernet1000

Neighbors connected via pseudowires:
Interface Peer Address VC ID Discovered Router ID Next Hop
Pw2000 10.0.0.1 10 10.0.0.1 10.0.0.1
Pw2001 10.0.0.2 10 10.1.1.2 10.0.0.2
Pw2002 10.0.0.3 10 10.1.1.3 10.0.0.3
Pw5 10.0.0.4 10 - 10.0.0.4
```

The following sample output from the **show l2vpn atom vc** command provides information on the virtual circuits:

```
Device# show l2vpn atom vc

Local intf Local circuit Dest address VC ID Status
-----
Et0/0.1 Eth VLAN 101 10.0.0.2 101 UP
Et0/0.1 Eth VLAN 101 10.0.0.3 201 DOWN
```

Feature Information for Configuring Virtual Private LAN Services

The following table provides release information about the feature or features described in this module. This table lists only the software release that introduced support for a given feature in a given software release train. Unless noted otherwise, subsequent releases of that software release train also support that feature.

Use Cisco Feature Navigator to find information about platform support and Cisco software image support. To access Cisco Feature Navigator, go to www.cisco.com/go/cfn. An account on Cisco.com is not required.

Table 11: Feature Information for Configuring Virtual Private LAN Services

Feature Name	Releases	Feature Information
Configuring Virtual Private LAN Services	Cisco IOS XE Release 3.13.0S	This feature was introduced on the Cisco ASR 920 Routers (ASR-920-12CZ-A, ASR-920-12CZ-D, ASR-920-4SZ-A, ASR-920-4SZ-D).

Layer 2 Protocol Tunneling

Customers at different sites connected across a service-provider network need to use various Layer 2 protocols to scale their topologies to include all remote sites, as well as the local sites. STP must run properly, and every VLAN should build a proper spanning tree that includes the local site and all remote sites across the

service-provider network. Cisco Discovery Protocol (CDP) must discover neighboring Cisco devices from local and remote sites.

VLAN Trunking Protocol (VTP) must provide consistent VLAN configuration throughout all sites in the customer network that are participating in VTP. Similarly, DTP, LACP, LLDP, PAgP, and UDLD can also run across the service-provider network.

When protocol tunneling is enabled, edge switches on the inbound side of the service-provider network encapsulate Layer 2 protocol packets with a special MAC address (0100.0CCD.CDD0) and send them across the service-provider network. Core switches in the network do not process these packets but forward them as normal (unknown multicast data) packets. Layer 2 protocol data units (PDUs) for the configured protocols cross the service-provider network and are delivered to customer switches on the outbound side of the service-provider network. Identical packets are received by all customer ports on the same VLANs with these results:

- Users on each of a customer's sites can properly run STP, and every VLAN can build a correct spanning tree based on parameters from all sites and not just from the local site.
- CDP discovers and shows information about the other Cisco devices connected through the service-provider network.
- VTP provides consistent VLAN configuration throughout the customer network, propagating to all switches through the service provider that support VTP.

Customers use Layer 2 protocol tunneling to tunnel BPDUs through a service-provider network without interfering with internal provider network BPDUs.



Note Layer 2 protocol tunneling is supported on EFPs, but not on switchports.



Note EFP with Xconnect is enhanced to transparently forward the Layer 2 Control Protocol (L2CP) frames at the hardware level. Use the following command to forward the L2CP frames except the CFM frames:

```
mac-address-table evc-xconnect l2pt-forward-all
```

In addition to the listed L2CP frames, 802.1x (0x888E) frames and MACSec (0x88E5) frames can be forwarded over EoMPLS by enabling this command globally.

In figure below, Customer X has four switches in the same VLAN, which are connected through the service-provider network. If the network does not tunnel PDUs, switches on the far ends of the network cannot properly run STP, CDP, and other Layer 2 protocols. For example, STP for a VLAN on a switch in Customer X, Site 1, will build a spanning tree on the switches at that site without considering convergence parameters based on Customer X's switch in Site 2. This could result in the topology shown in figure below.

Figure 9: Layer 2 Protocol Tunneling

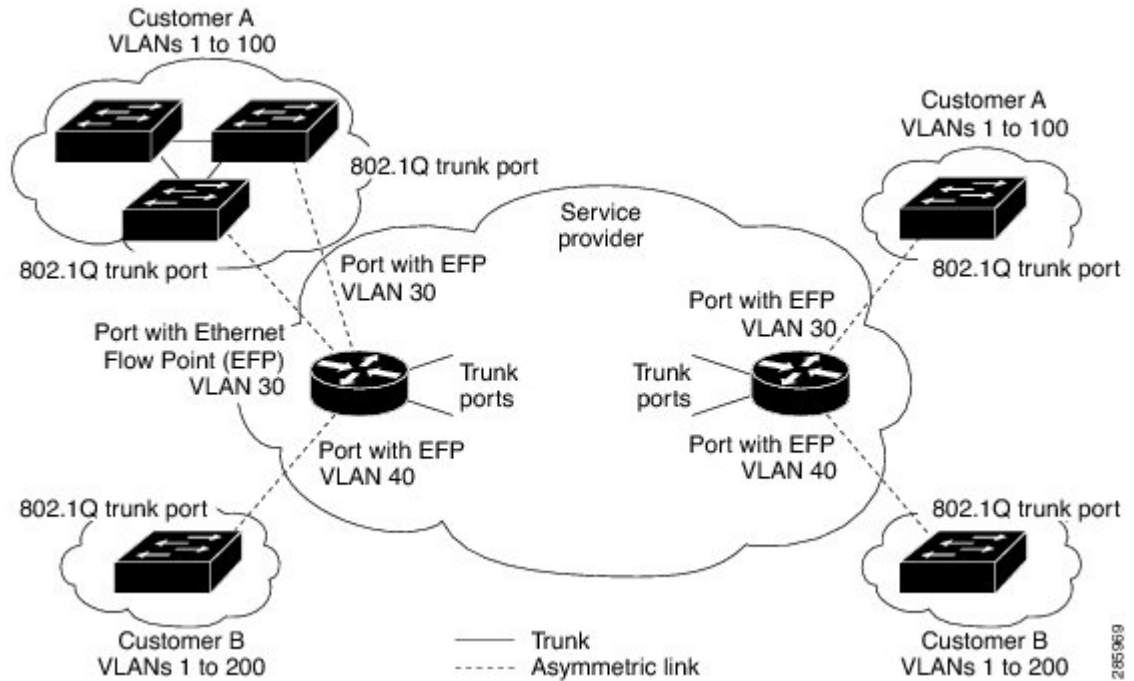
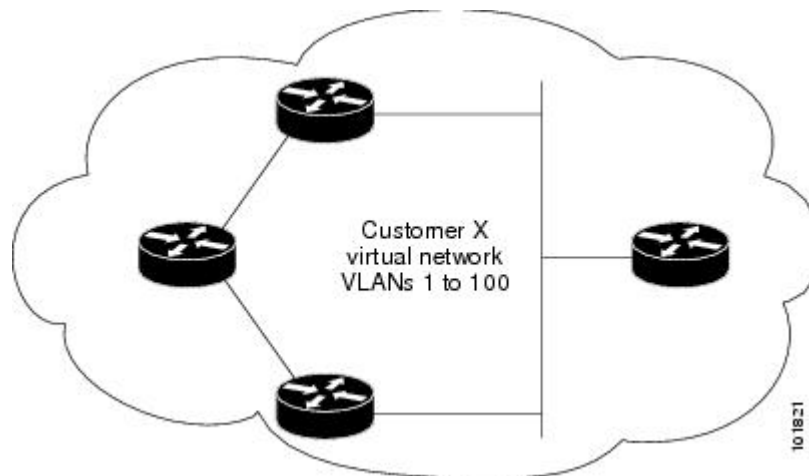

Figure 10: Layer 2 Network Topology without Proper Convergence



In a service-provider network, you can use Layer 2 protocol tunneling to enhance the creation of EtherChannels by emulating a point-to-point network topology. When you enable protocol tunneling (PAGP or LACP) on the service-provider switch, remote customer switches receive the PDUs and can negotiate the automatic creation of EtherChannels.

For example, in figure below, Customer A has two switches in the same VLAN that are connected through the SP network. When the network tunnels PDUs, switches on the far ends of the network can negotiate the automatic creation of EtherChannels without needing dedicated lines

Figure 11: Layer 2 Protocol Tunneling for EtherChannels

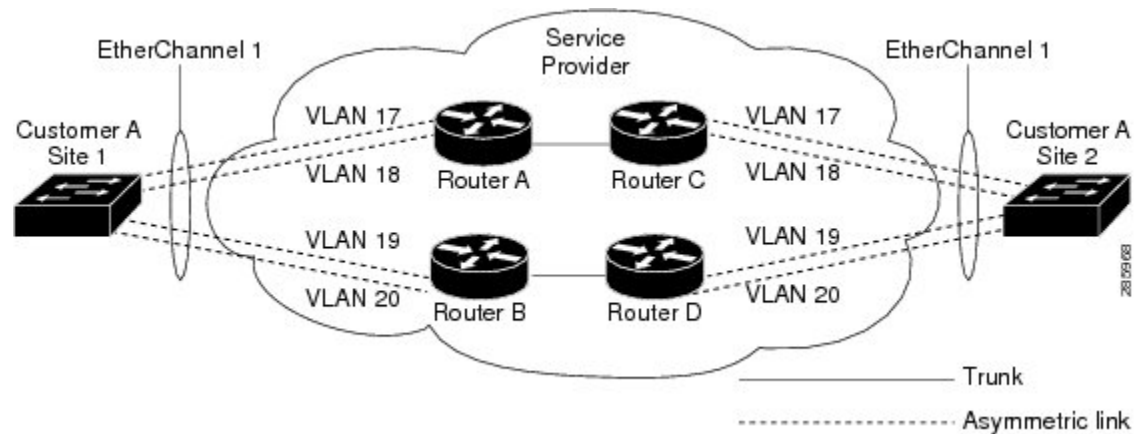

Use the **`l2protocol tunnel protocol service-instance`** configuration command to enable Layer 2 protocol tunneling on a service instance

Valid protocols include CDP, LACP, LLDP, PAgP, STP, UDLD, and VTP. If a protocol is not specified for a service instance, the protocol frame is dropped at the interface.

This is an example of Layer 2 protocol tunneling configuration:

```
Router (config)# interface gigabitethernet0/2
Router (config-if)# service instance 10 Ethernet
Router (config-if-srv)# encapsulation untagged , dot1q 200 second-dot1q 300
Router (config-if-srv)# l2protocol tunnel cdp stp vtp pagp lacp
Router (config-if-srv)# bridge-domain 10
```



Note To enable tunneling of most Layer 2 protocol, you must configure **`encapsulation untagged`** because Layer 2 protocol PDUs are usually untagged.

Layer 2 protocol tunneling statistics

The following command is used to view the Layer 2 protocol tunneling statistics:

`show ethernet service instance id service-instance id interface interface platform`

This is an example of Layer 2 protocol tunneling statistics:

```
2020#sh run int gi0/0/9
Building configuration...

Current configuration : 228 bytes
interface GigabitEthernet0/0/9
 no ip address
 media-type auto-select
 negotiation auto
 no keepalive
 service instance 200 ethernet
  encapsulation untagged
  l2protocol tunnel
  xconnect 2.2.2.2 1 encapsulation mpls
end
```

```
2020#show ethernet service instance id 200 inter gig 0/0/9 platform
```

```
Service Instance (EFP) L2 PDU Handling Info
```

EFP	CDP	STP	VTP	DTP	PAGP	LLDP	LACP	UDLD	LOAM	ESMC	ELMI	PTPPD
RES4	RES5	RES6	RES8	RES9	RESA	RESB	RESC	RESD	RESF	CFG	NH	
Gi0/0/9.Efp200	TUNL	TUNL	TUNL	DROP	TUNL	TUNL	TUNL	TUNL	TUNL	TUNL	TUNL	TUNL
	TUNL	TUNL	TUNL	TUNL	TUNL	TUNL	TUNL	TUNL	Y	N		

```
EFP L2PT Tunnel statistics
```

L2protocol	Encapped	Decapped
CDP:	0	0
STP:	4059	13661
VTP:	0	0
DTP:	0	0
PAGP:	0	0
LLDP:	0	0
LACP:	0	0
UDLD:	0	0
LOAM:	0	0
ESMC:	0	0
ELMI:	0	0
PTPPD:	0	0



Note Layer 2 Protocol Tunnel decap statistics increments on core port for Layer 2 Protocol Tunnel over BD/VPLS scenario and Layer 2 Protocol Tunnel.



CHAPTER 6

VPLS MAC Address Withdrawal

The VPLS MAC Address Withdrawal feature provides faster convergence by removing (or unlearning) MAC addresses that have been dynamically learned. A Label Distribution Protocol (LDP)-based MAC address withdrawal message is used for this purpose. A MAC list Type Length Value (TLV) is part of the MAC address withdrawal message. No configuration is needed.

- [Information About VPLS MAC Address Withdrawal, on page 159](#)
- [Additional References for Any Transport over MPLS, on page 161](#)
- [Feature Information for VPLS MAC Address Withdrawal, on page 162](#)

Information About VPLS MAC Address Withdrawal

VPLS MAC Address Withdrawal

The VPLS MAC Address Withdrawal feature provides faster convergence by removing (or unlearning) MAC addresses that have been dynamically learned. A Label Distribution Protocol (LDP)-based MAC address withdrawal message is used for this purpose. A MAC list Type Length Value (TLV) is part of the MAC address withdrawal message.

The **debug mpls ldp messages** and **debug mpls ldp session io** commands support monitoring of MAC address withdrawal messages being exchanged between LDP peers. Any Transport over Multiprotocol Label Switching (AToM) might provide other means to display or monitor MAC address withdrawal messages. The Tag Distribution Protocol (TDP) is not supported because AToM uses only LDP for the MAC address withdrawal message.

PE devices learn the remote MAC addresses and directly attached MAC addresses on customer-facing ports by deriving the topology and forwarding information from packets originating at customer sites. To display the number of MAC address withdrawal messages, enter the **show mpls l2transport vc detail** command, as shown in the following example:

```
Device# show mpls l2transport vc detail

Local interface: VFI TEST VFI up
MPLS VC type is VFI, interworking type is Ethernet
Destination address: 10.1.1.1, VC ID: 1000, VC status: up
Output interface: Se2/0, imposed label stack {17}
Preferred path: not configured
Default path: active
Next hop: point2point
```

```

Create time: 00:04:34, last status change time: 00:04:15
Signaling protocol: LDP, peer 10.1.1.1:0 up
  Targeted Hello: 10.1.1.1(LDP Id) -> 10.1.1.1
  MPLS VC labels: local 16, remote 17
  Group ID: local 0, remote 0
  MTU: local 1500, remote 1500
  Remote interface description:
  MAC Withdraw: sent 5, received 3
Sequencing: receive disabled, send disabled
VC statistics:
  packet totals: receive 0, send 0
  byte totals:   receive 0, send 0
  packet drops:  receive 0, send 0

```



Note The MAC Address feature is enabled by default. Some show commands may not display the MAC withdraw counters in the command output. This does not indicate that the feature is disabled.

VPLS MAC Address Withdrawal Using Commands Associated with L2VPN Protocol-Based Feature

The VPLS MAC Address Withdrawal feature provides faster convergence by removing (or unlearning) MAC addresses that have been dynamically learned. A Label Distribution Protocol (LDP)-based MAC address withdrawal message is used for this purpose. A MAC list Type Length Value (TLV) is part of the MAC address withdrawal message.

The **debug mpls ldp messages** and **debug mpls ldp session io** commands support monitoring of MAC address withdrawal messages being exchanged between LDP peers. Any Transport over Multiprotocol Label Switching (AToM) might provide other means to display or monitor MAC address withdrawal messages. The Tag Distribution Protocol (TDP) is not supported because AToM uses only LDP for the MAC address withdrawal message.

PE devices learn the remote MAC addresses and directly attached MAC addresses on customer-facing ports by deriving the topology and forwarding information from packets originating at customer sites. To display the number of MAC address withdrawal messages, enter the **show l2vpn atom vc detail** command, as shown in the following example:

```

Device# show l2vpn atom vc detail

Local interface: VFI TEST VFI up
MPLS VC type is VFI, interworking type is Ethernet
Destination address: 10.1.1.1, VC ID: 1000, VC status: up
  Output interface: Se2/0, imposed label stack {17}
  Preferred path: not configured
  Default path: active
  Next hop: point2point
Create time: 00:04:34, last status change time: 00:04:15
Signaling protocol: LDP, peer 10.1.1.1:0 up
  Targeted Hello: 10.1.1.1(LDP Id) -> 10.1.1.1
  MPLS VC labels: local 16, remote 17
  Group ID: local 0, remote 0
  MTU: local 1500, remote 1500
  Remote interface description:
  MAC Withdraw: sent 5, received 3
Sequencing: receive disabled, send disabled
VC statistics:

```

```
packet totals: receive 0, send 0
byte totals:  receive 0, send 0
packet drops:  receive 0, send 0
```

How MAC Address Withdrawal Works with H-VPLS N-PE Redundancy with MPLS Access

If the pseudowire between the user provider edge (U-PE) device and network provider edge (N-PE) device fails, the L2VPN Pseudowire Redundancy feature on the U-PE device activates the standby pseudowire. In addition, the U-PE device sends a Label Distribution Protocol (LDP) MAC address withdrawal request to the new N-PE device, which forwards the message to all pseudowires in the virtual private LAN service (VPLS) core and flushes its MAC address table.

If a switched virtual interface (SVI) bridge domain interface (BDI) on the N-PE device fails, the L2VPN Pseudowire Redundancy feature activates the standby pseudowire and the U-PE device sends a MAC withdrawal message to the newly active N-PE device.

How MAC Address Withdrawal Works with H-VPLS N-PE Redundancy with QinQ Access

If a failure occurs in the customer-switched network, a spanning-tree Topology Change Notification (TCN) is issued to the network provider edge (N-PE) device, which issues a Label Distribution Protocol (LDP)-based MAC address withdrawal message to the peer N-PE devices and flushes its MAC address table.

Additional References for Any Transport over MPLS

Related Documents

Related Topic	Document Title
Cisco IOS commands	Cisco IOS Master Command List, All Releases
MPLS commands	Cisco IOS Multiprotocol Label Switching Command Reference

Technical Assistance

Description	Link
The Cisco Support and Documentation website provides online resources to download documentation, software, and tools. Use these resources to install and configure the software and to troubleshoot and resolve technical issues with Cisco products and technologies. Access to most tools on the Cisco Support and Documentation website requires a Cisco.com user ID and password.	http://www.cisco.com/cisco/web/support/index.html

Feature Information for VPLS MAC Address Withdrawal

The following table provides release information about the feature or features described in this module. This table lists only the software release that introduced support for a given feature in a given software release train. Unless noted otherwise, subsequent releases of that software release train also support that feature.

Use Cisco Feature Navigator to find information about platform support and Cisco software image support. To access Cisco Feature Navigator, go to www.cisco.com/go/cfn. An account on Cisco.com is not required.

Table 12: Feature Information for VPLS MAC Address Withdrawal

Feature Name	Releases	Feature Information
VPLS MAC Address Withdrawal	Cisco IOS XE Release 3.13.0S	This feature was introduced on the Cisco ASR 920 Routers (ASR-920-12CZ-A, ASR-920-12CZ-D, ASR-920-4SZ-A, ASR-920-4SZ-D).



CHAPTER 7

VPLS BGP Signaling

The two primary functions of the Virtual Private LAN Service (VPLS) control plane are autodiscovery and signaling. The VPLS BGP Signaling feature enables you to use BGP as both an autodiscovery and a signaling protocol for VPLS, in accordance with RFC 4761.

- [Prerequisites for VPLS BGP Signaling, on page 163](#)
- [Information About VPLS BGP Signaling, on page 163](#)
- [How to Configure VPLS BGP Signaling, on page 164](#)
- [Configuration Examples for VPLS BGP Signaling, on page 167](#)
- [Additional References for VPLS BGP Signaling, on page 168](#)
- [Feature Information for VPLS BGP Signaling, on page 169](#)

Prerequisites for VPLS BGP Signaling

You are familiar with the concepts in the “Configuring Virtual Private LAN Services” and the “VPLS Autodiscovery BGP Based” modules of the *MPLS Layer 2 VPNs Configuration Guide* [MPLS Layer 2 VPNs Configuration Guide](#) .

Information About VPLS BGP Signaling

Overview of VPLS BGP Signaling

Prior to the VPLS BGP Signaling feature, BGP was used for autodiscovery and Label Distribution Protocol (LDP) for signaling in accordance with RFC 6074. The VPLS BGP Signaling feature enables you to use BGP as the control plane protocol for both autodiscovery and signaling in accordance with RFC 4761.

As specified in RFC 4761, internal BGP (iBGP) peers will exchange update messages of the L2VPN AFI/SAFI with L2VPN information to perform both autodiscovery and signaling. The BGP multiprotocol Network Layer Reachability Information (NLRI) consists of a Route Distinguisher (RD), VPLS Endpoint ID (VE ID), VE Block Offset (VBO), VE Block Size (VBS), and Label Base (LB).

The figure below shows the format of the NLRI for RFC 4761.

Figure 12: RFC 4761 NLRI

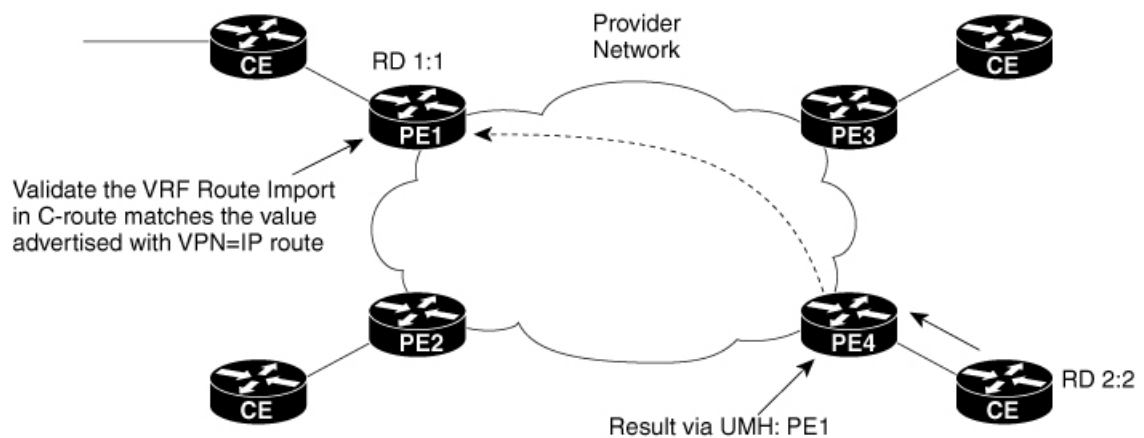

520687

Additional information, such as next-hop, route target (specified for a VPLS instance), and other Layer 2 data are carried in the BGP extended community attributes. A route target-based import/export mechanism similar to L3VPN is performed by BGP to filter L2VPN NLRIs of a particular VPLS instance.

Whether you use BGP signaling (RFC 4761) or LDP signaling (RFC 6074) depends on the commands you specify. To enable the VPLS BGP Signaling feature, use the **autodiscovery bgp signaling bgp** command in L2 VFI configuration mode. This command is supported on a per VPLS instance basis.

If a BGP session receives an invalid (that is, not matching the configuration) BGP update advertisement (update or withdraw), it is ignored.

BGP's main task in supporting VPLS is route distribution via the L2VPN address family and interactions with L2VPN. Interactions between BGP and other components remain the same. Basic BGP functionalities like best-path selection, next-hop handling, and update generation, continue to operate in the same manner with VPLS BGP signaling. BGP RT constraint works seamlessly with the BGP VPLS Signaling feature.

The above example shows sample configuration on one PE. Similar configuration can be mirrored on other PEs.

How to Configure VPLS BGP Signaling

Configuring VPLS BGP Signaling

Before you begin



Note For more information, see *Configuring Virtual Private Lan Services*.

Procedure

Step 1

enable

Example:

```
Device> enable
```

Enables privileged EXEC mode.

- Enter your password if prompted.

Step 2

configure terminal

Example:

```
Device# configure terminal
```

Enters global configuration mode.

Step 3

l2vpn vfi context *name*

Example:

```
Device(config)# l2vpn vfi context vfi1
```

Establishes a L2VPN virtual forwarding interface (VFI) between two or more separate networks and enters Layer 2 VFI configuration mode.

Step 4

vpn id *vpn-id*

Example:

```
Device(config-vfi)# vpn id 100
```

Configures a VPN ID for the VPLS domain.

Step 5

autodiscovery bgp signaling {*bgp* | *ldp*} [*template template-name*]

Example:

```
Device(config-vfi)# autodiscovery bgp signaling bgp
```

Enables BGP signaling and discovery or LDP signaling and enters L2VPN VFI autodiscovery configuration mode.

Note For the VPLS BGP Signaling feature use the **autodiscovery bgp signaling bgp** command.

Step 6

ve id *ve-id*

Example:

```
Device(config-vfi-autodiscovery)# ve id 1001
```

Specifies the VPLS endpoint (VE) device ID value. The VE ID identifies a VFI within a VPLS service. The VE device ID value is from 1 to 16384.

Step 7

ve range *ve-range*

Example:

```
Device(config-vfi-autodiscovery)# ve range 12
```

Specifies the VE device ID range value. The VE range overrides the minimum size of VE blocks. The default minimum size is 10. Any configured VE range must be higher than 10.

Step 8 **exit****Example:**

```
Device(config-vfi-autodiscovery)# exit
```

Exits L2VPN VFI autodiscovery configuration mode and enters L2VPN VFI configuration mode.

Step 9 **exit****Example:**

```
Device(config-vfi)# exit
```

Exits L2VPN VFI configuration mode and enters global configuration mode.

Step 10 **router bgp *autonomous-system-number*****Example:**

```
Device(config)# router bgp 100
```

Enters router configuration mode to create or configure a BGP routing process.

Step 11 **bgp graceful-restart****Example:**

```
Device(config-router)# bgp graceful-restart
```

Enables the BGP graceful restart capability and BGP nonstop forwarding (NSF) awareness.

Step 12 **neighbor *ip-address* remote-as *autonomous-system-number*****Example:**

```
Device(config-router)# neighbor 10.10.10.1 remote-as 100
```

Configures peering with a BGP neighbor in the specified autonomous system.

Step 13 **address-family l2vpn [*vpls*]****Example:**

```
Device(config-router)# address-family l2vpn vpls
```

Specifies the L2VPN address family and enters address family configuration mode.

- The optional **vpls** keyword specifies that VPLS endpoint provisioning information is to be distributed to BGP peers.

In this example, an L2VPN VPLS address family session is created.

Step 14 **neighbor ip-address activate****Example:**

```
Device(config-router-af)# neighbor 10.10.10.1 activate
```

Enables the neighbor to exchange information for the L2VPN VPLS address family with the local device.

Step 15 **neighbor ip-address send-community [both | standard | extended]****Example:**

```
Device(config-router-af)# neighbor 10.10.10.1 send-community extended
```

Specifies that a communities attribute should be sent to a BGP neighbor.

- In this example, an extended communities attribute is sent to the neighbor at 10.10.10.1.

Step 16 **neighbor ip-address suppress-signaling-protocol ldp****Example:**

```
Device(config-router-af)# neighbor 10.10.10.1 suppress-signaling-protocol ldp
```

Suppresses LDP signaling and enables BGP signaling.

- In this example LDP signaling is suppressed (and BGP signaling enabled) for the neighbor at 10.10.10.1.

Step 17 **end****Example:**

```
Device(config-router-af)# end
```

Exits address family configuration mode and returns to privileged EXEC mode.

Step 18 **show bgp l2vpn vpls {all | rd route-distinguisher}****Example:**

```
Device# show bgp l2vpn vpls all
```

(Optional) Displays information about the L2VPN VPLS address family.

Configuration Examples for VPLS BGP Signaling

Example: Configuring and Verifying VPLS BGP Signaling

```
l2vpn vfi context vfi1
vpn id 100
autodiscovery bgp signaling bgp
ve id 1001
```

```

    ve range 10
    !
    !
router bgp 100
  bgp graceful-restart
  neighbor 192.168.200.224 remote-as 100
  neighbor 192.168.200.224 update-source Loopback1
  !
  address-family l2vpn vpls
    neighbor 192.168.200.224 activate
    neighbor 192.168.200.224 send-community extended
    neighbor 192.168.200.224 suppress-signaling-protocol ldp
  exit-address-family
  !
show bgp l2vpn vpls all

```

Network	Next Hop	Metric	LocPrf	Weight	Path
Route Distinguisher: 100:100					
*>100:100:VEID-1001:Blk-1001/136	10.0.0.0			32768	?
*>i 100:100:VEID-1003:Blk-1000/136	192.168.200.224		0	100	0 ?

Additional References for VPLS BGP Signaling

Related Documents

Related Topic	Document Title
Cisco IOS commands	Cisco IOS Master Command List, All Releases
BGP commands: complete command syntax, command mode, defaults, command history, usage guidelines, and examples.	Cisco IOS IP Routing: BGP Command Reference
Configuring Virtual Private LAN Services	MPLS Layer 2 VPNs Configuration Guide MPLS Layer 2 VPNs Configuration Guide
Configuring Access Port	Configuring Virtual Private LAN Services, MPLS Layer 2 VPNs Configuration Guide MPLS Layer 2 VPNs Configuration Guide
VPLS Autodiscovery BGP Based	MPLS Layer 2 VPNs Configuration Guide MPLS Layer 2 VPNs Configuration Guide

Standards and RFCs

Standard/RFC	Title
RFC 4761	<i>Virtual Private LAN Service (VPLS) Using BGP for Auto-Discovery and Signaling</i>
RFC 6074	<i>Provisioning, Auto-Discovery, and Signaling in Layer 2 Virtual Private Networks (L2VPNs)</i>

Technical Assistance

Description	Link
The Cisco Support and Documentation website provides online resources to download documentation, software, and tools. Use these resources to install and configure the software and to troubleshoot and resolve technical issues with Cisco products and technologies. Access to most tools on the Cisco Support and Documentation website requires a Cisco.com user ID and password.	http://www.cisco.com/cisco/web/support/index.html

Feature Information for VPLS BGP Signaling

The following table provides release information about the feature or features described in this module. This table lists only the software release that introduced support for a given feature in a given software release train. Unless noted otherwise, subsequent releases of that software release train also support that feature.

Use Cisco Feature Navigator to find information about platform support and Cisco software image support. To access Cisco Feature Navigator, go to <https://cfngn.cisco.com/>. An account on Cisco.com is not required.

Table 13: Feature Information for VPLS BGP Signaling

Feature Name	Releases	Feature Information
VPLS BGP Signaling		<p>The VPLS BGP Signaling feature enables you to use BGP as both an autodiscovery and signaling protocol for VPLS, in accordance with RFC 4761.</p> <p>The following commands were introduced or modified: autodiscovery (MPLS), neighbor suppress-signaling-protocol, show bgp l2vpn vpls, and ve.</p> <p>In Cisco IOS XE Release 3.8S, support was added for the Cisco ASR 903 router.</p>



CHAPTER 8

EVPN Virtual Private Wire Service (VPWS) Single Homed

Effective Release Cisco IOS XE 3.18, this feature is now supported on Cisco ASR 920 Series Aggregation Services Router, EVPN-VPWS single homed is a BGP control plane solution for point-to-point services. It has the ability to forward traffic from or to one network to another using the Ethernet Segment without MAC lookup.

EVPN VPWS single homed technology works on IP and MPLS core. IP core to support BGP and MPLS core for switching packets between the endpoints.

- [Information About EVPN-VPWS, on page 171](#)
- [Prerequisites for EVPN-VPWS, on page 172](#)
- [Restrictions for EVPN-VPWS, on page 172](#)
- [How to Configure EVPN-VPWS, on page 173](#)
- [Configuration Examples for EVPN-VPWS Instance, on page 179](#)
- [Additional References for EVPN-VPWS, on page 181](#)

Information About EVPN-VPWS

The EVPN-VPWS solution supports per EVI Ethernet Auto Discovery route. EVPN defines a new BGP Network Layer Reachability Information (NLRI) that is used to carry all EVPN routes. BGP Capabilities Advertisement is used to ensure that two speakers support EVPN NLRI (AFI 25, SAFI 70) as per RFC 4760.

The architecture for EVPN VPWS is that the PEs run Multi-Protocol BGP in control-plane. The following image describes the EVPN-VPWS over SR configuration:

Figure 13: EVPN-VPWS over SR Configuration

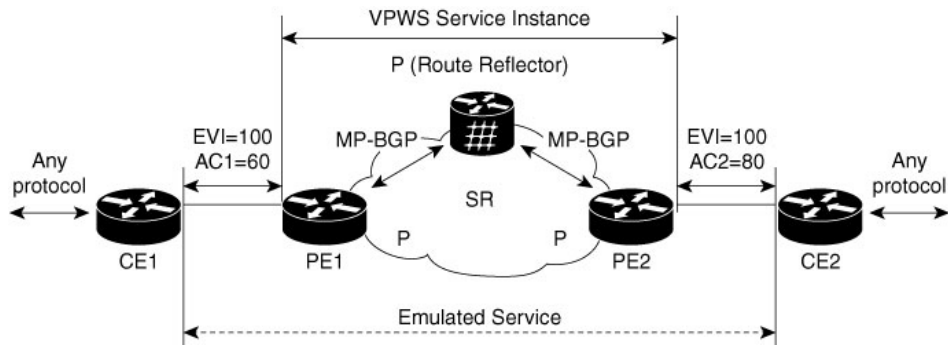

Benefits of EVPN-VPWS Single Homed

- Scalability is achieved without signaling pseudowires.
- There is ease of provisioning.
- Pseudowires (PWs) are not used.
- EVPN-VPWS Single Homed leverages BGP best-path selection (optimal forwarding).

Prerequisites for EVPN-VPWS

- Ensure BGP is configured for EVPN SAFI.
- MPLS LDP core is used for MPLS LSP between PE. MPLS LDP core is required when Segment Routing is not used.
- CE-facing interface, such as service instance, is Ethernet family without IP address on PE.
- BGP session between PEs with 'address-family l2vpn evpn' to exchange EVPN routes.
- A BGP Route Reflector is supported.
- IGP, such as ISIS, core for IP reachability between PEs and BGP next-hop reachability.

Restrictions for EVPN-VPWS

- The combination of EVPN ID and VPWS Instance ID must be unique according to ASN.
- Cisco Multiprotocol Label Switching Traffic Engineering (MPLS-TE) core is *not* supported.
- inter-AS Option B is *not* supported.
- NSR is *not* supported for l2vpn family.
- Ensure that Cisco Nonstop Forwarding (NSF) is configured on BGP, OSPF(iBGP), and MPLS.
- NSF is supported, you should see neigh flap, but not traffic drop.

- Without NSF, if you are doing Stateful Switchover (SSO), then you would see traffic drop for l2vpn evpn traffic.
- ELB is *not* supported on EVPN.
- L2VPN traffic is not load balanced for inner payload src-ip, dst-ip, src-dst-ip hashing algorithms in the egress PoCh interface. We recommend you to use other hashing algorithms like src-mac, dst-mac, src-dst-mac.

Scaling Information

Number of supported EVPN-VPWS service instances is 2000 on Cisco ASR 920 Series Aggregation Services Router.

How to Configure EVPN-VPWS

The following steps are performed to configure EVPN-VPWS

- Configuring BGP for EVPN-VPWS
- Configuring EVPN-VPWS Instance

Configuring BGP for EVPN-VPWS

To configure EVPN-VPWS in BGP, follow these steps:

Procedure

```
router bgp 1
address-family l2vpn evpn
neighbor 192.168.0.1 activate
exit-address-family
```

Configuring EVPN-VPWS Instance

To configure EVPN VPWS instance, follow these steps:

Procedure

```
enable
configure terminal
l2vpn evpn instance 11 point-to-point
vpws context test
service target 100 source 100
member GigabitEthernet0/0/0 service-instance 10
no shut
end
```

Rewrite for EVI Service Instance

You need to have the rewrite command when the VLANs are mismatched on the remote ACs. This allows ingress traffic movement. To configure EVPN-VPWS service instance for rewrite, follow these steps:

Procedure

```
interface GigabitEthernet0/0/1
service instance 2 ethernet
encapsulation dot1q 2
rewrite ingress tag pop 1 symmetric
end
```

Configuring EVPN-VPWS for Logging

To configure EVPN-VPWS for logging, follow these steps:

Procedure

```
enable
configure terminal
l2vpn evpn logging vc-state
end
```

Verifying EVPN-VPWS Instance

Verifying EVPN-VPWS Configuration

You can verify the configuration using the following show commands:

- **show l2vpn evpn summary**
- **show l2vpn evpn evi (<evpn-id> | all) [detail]**
- **show l2vpn evpn rib ead [detail] |evi**
- **show l2vpn evpn checkpoint**
- **show l2vpn evpn route-target [<rt>]**
- **show bgp l2vpn evpn**
- **show l2vpn evpn memory [detail]**

This command displays a summary of L2VPN EVPN with total number of EVIs, VCs and routes.

```
show l2vpn evpn summary

L2VPN EVPN VPWS:
EVI (point-to-point): 1
Total VCs: 1
  1 up, 0 down, 0 admin-down, 0 hot-standby, 0 other
Total EVPN EAD routes: 2
  1 local, 1 remote
Total EVI EAD routes: 2
  1 local, 1 remote (1 in-use)
BGP: ASN 1, address-family l2vpn evpn configured
Router ID: 192.168.0.2
```

This command displays brief or detail info for EVIs.

```
show l2vpn evpn evi 100 det

EVPN instance: 100 (point-to-point)
RD: 192.168.0.2:100 (auto)
```

```

Import-RTs: 1:100
Export-RTs: 1:100
Total VCs: 1
    1 up, 0 down, 0 admin-down, 0 hot-standby, 0 other
Total EAD routes: 2
    1 local, 1 remote (1 in-use)

```

This command displays the contents of the global EVPN route.

```
show l2vpn evpn rib ead
```

```

+- Origin of entry                               (i=iBGP/e=eBGP/L=Local)
| +- Best path                                   (Yes/No)?
| |
v v
O B          RD          Ethernet Segment Id    Eth Tag    Next Hop
+-----+-----+-----+-----+-----+-----+
i Y 192.168.0.3:100      0000.0000.0000.0000.0000 2          192.168.0.3
L - 192.168.0.2:100      0000.0000.0000.0000.0000 1

```

```
show l2vpn evpn rib ead evi
```

```

+- Origin of entry                               (i=iBGP/e=eBGP/L=Local)
| +- Provisioned                                 (Yes/No)?
| | +- Best path                                 (Yes/No)?
| | |
v v v
O P B  EVI    Ethernet Segment Id    Eth Tag    Next Hop    Label
+-----+-----+-----+-----+-----+-----+
i Y Y 100     0000.0000.0000.0000.0000 2          192.168.0.3  16
L - - 100     0000.0000.0000.0000.0000 1          192.168.0.3  16

```

```
show l2vpn evpn checkpoint
```

```

EVPN Checkpoint info for active RP
Checkpointing is allowed
Bulk-sync checkpointed state for 0 VC
ISSU Context:95, Compatible:1, Negotiated L2HW types: 0

```

This command displays the contents of the global route-target (RT).

```
show l2vpn evpn route-target
```

```

Route Target          EVPN Instances
1:100                  100

```

```
show bgp l2vpn evpn
```

```

BGP table version is 4, local router ID is 192.168.0.2
Status codes: s suppressed, d damped, h history, * valid, > best, i - internal,
               r RIB-failure, S Stale, m multipath, b backup-path, f RT-Filter,
               x best-external, a additional-path, c RIB-compressed,
Origin codes: i - IGP, e - EGP, ? - incomplete
RPKI validation codes: V valid, I invalid, N Not found

```

```

Network          Next Hop          Metric LocPrf Weight Path
Route Distinguisher: 192.168.0.2:100
 *> [1][192.168.0.2:100][00000000000000000000][5]/23
      ::
Route Distinguisher: 192.168.0.3:100
 *>i [1][192.168.0.3:100][00000000000000000000][6]/23
      192.168.0.3          0      100      0 ?

```

This command displays brief or detail EVPN memory usage.

```
show l2vpn evpn memory
```

Allocator-Name	In-use/Allocated	Count
EVPN DB	648/65632 (0%)	[9] Chunk
EVPN EAD DB	432/65632 (0%)	[6] Chunk
EVPN EAD Handle Table	21856/22040 (99%)	[2]
EVPN EAD Paths	104/65632 (0%)	[1] Chunk
EVPN EAD Routes	96/65648 (0%)	[2] Chunk
EVPN RIB MGR	976/1344 (72%)	[4]
EVPN RIB NHs	0/10096 (0%)	[0] Chunk
EVPN RIB RTs	96/10096 (0%)	[2] Chunk
EVPN RIB msg	0/10096 (0%)	[0] Chunk
EVPN Thread	1684/2144 (78%)	[5]
EVPN context chunk	768/32864 (2%)	[1] Chunk
EVPN context handle table	70968/71152 (99%)	[2]
EVPN dtrace elem per-cont	1280/65632 (1%)	[20] Chunk
EVPN dtrace stridx	1194876/1194968 (99%)	[1]
EVPN dtrace stridx freeeli	132764/132856 (99%)	[1]
EVPN dtrace stridx hash	76/168 (45%)	[1]
EVPN dtrace stridx slots	265532/265624 (99%)	[1]
EVPN dtrace stridx2slot	132764/132856 (99%)	[1]
EVPN instance chunk	168/10096 (1%)	[1] Chunk
EVPN rt-db ee	124/216 (57%)	[1]
EVPN rt-db rte	204/296 (68%)	[1]

Total allocated: 2.121 Mb, 2172 Kb, 2225088 bytes

Verifying EVPN-VPWS Configuration for Logging

You can verify the logging using the **show l2vpn evpn vc** command.

This command displays brief information for VCs.

```
show l2vpn evpn vc all
```

EVPN ID	Source	Target	Type	Name/Interface	Status
100	1	2	p2p	vc100 Et0/0	up up

This command displays detail information for VCs.

```
show l2vpn evpn vc all detail
```

```
EVPN name: vc100, state: up, type: point-to-point
EVPN ID: 100
VPWS Service Instance ID: Source 1, Target 2
Labels: Local 16, Remote 16
Next Hop Address: 192.168.0.3
Associated member Et0/0 is up, status is up
Dataplane:
  SSM segment/switch IDs: 4098/4097 (used), PWID: 1
Rx Counters
  78 input transit packets, 26425 bytes
  0 drops
Tx Counters
  79 output transit packets, 28240 bytes
  0 drops
5 VC FSM state transitions, Last 5 shown
  Prov: Idle -> Prov, Tue Sep 29 13:15:37.848 (00:52:21 ago)
  AdmUp: Prov -> LocWait, Tue Sep 29 13:15:40.287 (00:52:18 ago)
  LocUp: LocWait -> RemWait, Tue Sep 29 13:15:40.287 (00:52:18 ago)
  RemUp: RemWait -> Act, Tue Sep 29 13:17:19.368 (00:50:39 ago)
  DpUp: Act -> Est, Tue Sep 29 13:17:19.371 (00:50:39 ago)
```

Troubleshooting

Virtual Circuit (VC) is in Down state

EVPN VPWS protocol has no communication of VC state between endpoints. Furthermore LDP transport LSP is unidirectional and there is no end-to-end checking for connectivity. VC can be up on one end and down on the other end in the following cases:

- Core-facing mpls dataplane down on one side only. For example, if loopback configured with /24 on one-end and configured correctly with /32 at other end.
- UUT has no remote EVPN EAD route from peer. Several variants:
 - Peer never sent it.
 - Peer sent it, but RT mismatch: No intersection between UUT Import-RT and peer Export-RT.
 - Peer sent it, RT matches, but etag mismatch: For service etags tgt/src, UUT has x/y, peer has y/z.

Problem VC is in down state.

Possible Cause None

Solution Perform these steps to check whether the VC is not active:

Solution

- **Solution** Check if any VC is not active.
- **Solution** Identify EVIs that has not got an active VCs
- **Solution** Gather information for the EVIs that has not got an active VCs
- **Solution** Locate the not active VCs for the EVI
- **Solution** Display detail information of the not active VC

Solution

```
show l2vpn evpn vc all detail
EVPN name: vc100, state: up, type: point-to-point
EVPN ID: 100
VPWS Service Instance ID: Source 1, Target 2
Labels: Local 16, Remote 16

// Must have a valid Local Label. If missing, contact support.

// Must have valid Remote Label. If missing, then there is no matching remote route.
Cross-check with BGP: 'show bgp l2vpn evpn [...] detail'.

Next Hop Address: 192.168.0.3

// Must have valid Next Hop Address. If missing, then there is no matching remote route.
Cross-check with BGP: 'show bgp l2vpn evpn [...] detail'.

Associated member Et0/0 is up, status is up

// AC must be up. If not up, check why.

Dataplane:
SSM segment/switch IDs: 4098/4097 (used), PWID: 1
```

```

Rx Counters
  78 input transit packets, 26425 bytes
  0 drops
Tx Counters
  79 output transit packets, 28240 bytes
  0 drops
5 VC FSM state transitions, Last 5 shown
  Prov: Idle -> Prov, Tue Sep 29 13:15:37.848 (00:52:21 ago)
  AdmUp: Prov -> LocWait, Tue Sep 29 13:15:40.287 (00:52:18 ago)
  LocUp: LocWait -> RemWait, Tue Sep 29 13:15:40.287 (00:52:18 ago)
  RemUp: RemWait -> Act, Tue Sep 29 13:17:19.368 (00:50:39 ago)
  DpUp: Act -> Est, Tue Sep 29 13:17:19.371 (00:50:39 ago)

// Pay close attention to last line of VC FSM history. The format is:
// <Event>: <OldState> -> <NewState>
// Troubleshooting info appears below.

```

VC FSM History

Problem The state of the VC is Prov — Provisioned: VC is disabled.

Possible Cause None

Solution Perform these steps for a solution to the state:

- **Solution** Check BGP is running.
- **Solution** Check BGP 'address-family l2vpn evpn' is configured.
- **Solution** Check VC is not shutdown.

Problem The state of the VC is LocWait — Local-Wait: Waiting for local AC information to come up.

Possible Cause None

Solution Check AC is up.

Problem The state of the VC is Act — Activating: Control plane ok. Trying to activate dataplane.

Possible Cause None

- **Solution** Check core facing information is up.
- **Solution** Check Segment-Routing is configured and preferred.

Remote-Wait State

Problem The state of the VC is RemWait — Remote-Wait: Waiting for matching remote route.

Possible Cause This state occurs due to no matching remote route for the VC. A matching remote route means all of the following are true:

- Route is present in BGP. Requires a local EVI to have route target in the route.
- Remote path is best path.
- Route is present in global EVPN route.
- Route is present in EVI route. Requires the EVI to have route target in the route.
- Route has ETag which matches the VC source identity. (**service target <tgt-id> source <src-id>**).

Solution Perform these steps to check whether the VC is in remote wait state:

Solution

- Check for EVI configuration mismatch.
- Check for VC configuration mismatch.
- Check if the remote route is present in BGP.
 - If no remote route then check if
 - remote route was discarded by BGP due to RT filter
 - peer did not send route to UUT
 - EVI or VC configuration mismatch
 - all the prerequisites are satisfied
 - If a remote route is present in global EVPN then check if the remote route is present in EVI route.
 - **Solution** Check for EVI or VC configuration mismatch.

Configuration Examples for EVPN-VPWS Instance

The following example is for configuration for an EVPN-VPWS instance.

Example: EVPN-VPWS Instance Configuration

```
Router(config)#l2vpn evpn instance 11 point-to-point
Router(config-evpn-evi)#rd 1:1
Router(config-evpn-evi)#vpws context test
Router(config-evpn-vpws)#service target 100 source 100
Router(config-evpn-vpws)#member GigabitEthernet0/0/0 service-instance 10
Router(config-evpn-vpws)#no shut
```

The following example has running configurations on PE1 and PE2

Example: EVPN-VPWS PE1 configuration

```
interface Loopback0
 ip address 10.1.1.1 255.255.255.255
 ip ospf 1 area 0
!
interface GigabitEthernet0/0/0
 description CE1 facing
 no ip address
!
service instance 300 ethernet
 encapsulation dot1q 300
 rewrite ingress tag pop 1 symmetric

l2vpn evpn instance 100 point-to-point
!
vpws context vc100
 service target 2 source 1
 member GigabitEthernet0/0/0 service-instance 300
!
interface GigabitEthernet0/0/1
 description Core facing
 ip address 10.0.1.1 255.255.255.0
 ip ospf 1 area 0
 mpls ip
```

```

!
router ospf 1
  router-id 10.1.1.1
!
router bgp 1
  bgp router-id 10.1.1.1
  neighbor 2.2.2.2 remote-as 1
  neighbor 2.2.2.2 update-source Loopback0
!
  address-family ipv4
    neighbor 2.2.2.2 activate
  exit-address-family
!
  address-family l2vpn evpn
    neighbor 2.2.2.2 activate
  exit-address-family
!
l2vpn evpn instance 100 point-to-point
!
  vpws context vc100
    service target 2 source 1
    member GigabitEthernet0/0/0
!
mpls ldp router-id Loopback0
!

```

Example: EVPN-VPWS PE2 configuration

```

interface Loopback0
  ip address 2.2.2.2 255.255.255.255
  ip ospf 1 area 0
!
interface GigabitEthernet0/0/0
  description CE2 facing
  no ip address
!
service instance 300 ethernet
  encapsulation dot1q 300
  rewrite ingress tag pop 1 symmetric

  l2vpn evpn instance 100 point-to-point
!
  vpws context vc100
  service target 2 source 1
  member GigabitEthernet0/0/0 service-instance 300

interface GigabitEthernet0/0/1
  description Core facing
  ip address 10.0.1.2 255.255.255.0
  ip ospf 1 area 0
  mpls ip
!
router ospf 1
  router-id 2.2.2.2
!
router bgp 1
  bgp router-id 2.2.2.2
  neighbor 10.1.1.1 remote-as 1
  neighbor 10.1.1.1 update-source Loopback0
!
  address-family ipv4
    neighbor 10.1.1.1 activate

```



```

exit-address-family
!
address-family l2vpn evpn
 neighbor 10.1.1.1 activate
exit-address-family
!
l2vpn evpn instance 100 point-to-point
!
vpws context vc100
 service target 1 source 2
 member GigabitEthernet0/0/0
!
mpls ldp router-id Loopback0
!

```

Additional References for EVPN-VPWS

Related Documents

Related Topic	Document Title
Cisco IOS commands	Cisco IOS Master Commands List, All Releases

Standards and RFCs

Standard/RFC	Title
RFC 7432	<i>BGP MPLS-Based Ethernet VPN</i>
Standard	<i>VPWS support in EVPN</i>

MIBs

MIB	MIBs Link
•	—

Technical Assistance

Description	Link
<p>The Cisco Support website provides extensive online resources, including documentation and tools for troubleshooting and resolving technical issues with Cisco products and technologies.</p> <p>To receive security and technical information about your products, you can subscribe to various services, such as the Product Alert Tool (accessed from Field Notices), the Cisco Technical Services Newsletter, and Really Simple Syndication (RSS) Feeds.</p> <p>Access to most tools on the Cisco Support website requires a Cisco.com user ID and password.</p>	<p>http://www.cisco.com/cisco/web/support/index.html</p>



CHAPTER 9

N:1 PVC Mapping to PWE with Nonunique VPIs

The N:1 PVC Mapping to PseudoWire Emulation (PWE) with Nonunique virtual path identifiers (VPIs) feature maps one or more ATM permanent virtual circuits (PVCs) to a single pseudowire (PW). There are two modes of AAL0 encapsulation, N:1 and 1:1 mapping. In N:1 mapping, multiple unrelated virtual path identifier/virtual channel identifier (VPI/VCI) are carried over a single Multiprotocol Label Switching (MPLS) PW. This is an efficient mapping method because less resources are used from the MPLS network. In 1:1 mapping, a single VPI/VCI is carried over a single MPLS PW. Benefits of this feature include the following:

- Aggregate quality of service (QoS) can be applied to related PVCs.
- Bandwidth is conserved with the reduction in the number of pseudowires that are used.
- [Restrictions for N:1 PVC Mapping to PWE with Nonunique VPIs, on page 183](#)
- [Information About N:1 PVC Mapping to PWE with Nonunique VPIs, on page 184](#)
- [How to Configure N:1 PVC Mapping to PWE with Nonunique VPIs, on page 184](#)
- [Configuration Examples for N:1 PVC Mapping to PWE with Nonunique VPIs, on page 186](#)
- [Verifying the N:1 PVC Mapping to PWE with Nonunique VPIs Configuration, on page 187](#)
- [Additional References, on page 187](#)

Restrictions for N:1 PVC Mapping to PWE with Nonunique VPIs

- N:1 permanent virtual circuits (PVC) mapping configuration is supported only on multipoint subinterfaces; it is not supported on main interfaces or point-to-point subinterfaces.
- N:1 PVC mapping mode is not supported on Access Circuit Redundancy subinterfaces.
- Preconfigured PVCs cannot exist on the multipoint subinterface on which you want to configure N:1 PVC mapping.
- An attachment circuit that has been bound to a pseudowire cannot be removed unless all Layer 2 virtual circuits (VCs) have been removed.
- Layer 3 PVCs cannot be configured on N:1 subinterfaces.
- Cell packing values configured under a VC class attached to the PVC, main interface, or subinterface will not be inherited by N:1 PVCs.
- Operation, Administration, and Maintenance (OAM) functionality is not supported on N:1 Layer 2 PVCs. OAM cells coming from the customer edge (CE) network will be treated as normal data traffic and will traverse through the pseudowire.

- Only ATM adaptation layer type 0 (AAL0) encapsulation is supported for N:1 PVCs.
- The service policy configuration can be configured only at the subinterface level for N:1 PVCs.
- ATM N:1 and PVP modes cannot be configured on different subinterfaces that belong to a physical interface.
- You cannot change the ATM interface mode from point-to-point to multipoint or from multipoint to point-to-point.
- If you change a layer 2 ATM interface to a layer 3 ATM interface, traffic will not flow.

Information About N:1 PVC Mapping to PWE with Nonunique VPIs

N:1 PVC Mapping to PWE with Nonunique VPIs Feature Description

To transport ATM cells over Multiprotocol Label Switching (MPLS), a VC is established between the provider edge (PE) routers on both ends of the MPLS backbone. With the N:1 permanent virtual circuit (PVC) Mapping to PseudoWire Emulation (PWE) with Nonunique VPIs feature, multiple PVCs irrespective of their Virtual Path Identifiers (VPIs), are transported over a single pseudowire configured on a subinterface. (“N:1” refers to the number of PVCs transported over one pseudowire). ATM cells are packed together in a single frame and sent over the single pseudowire. The ATM cell header information is packed together with the cell payload on a per-cell basis in the packets so that packets received at the egress end are unpacked and the ATM cells are mapped to the respective PVCs.

In N:1 PVC mapping mode, the device can pack cells only from a single PVC in an MPLS packet to transmit over a pseudowire; cells from multiple PVCs cannot be packed in a single MPLS packet and mapped to a single pseudowire for transmission. However, if a device receives an MPLS packet that is packed with cells from multiple PVCs, then those cells will be unpacked and sent to the respective PVCs.

How to Configure N:1 PVC Mapping to PWE with Nonunique VPIs

Configuring N:1 PVC Mapping to PWE with Nonunique VPIs

Procedure

	Command or Action	Purpose
Step 1	enable Example: Device> enable	Enables privileged EXEC mode. <ul style="list-style-type: none"> • Enter your password if prompted.

	Command or Action	Purpose
Step 2	configure terminal Example: Device# configure terminal	Enters global configuration mode.
Step 3	interface atm slot/subslot/port Example: Device(config)# interface atm 9/1/1	Enables the ATM interface and enters interface configuration mode.
Step 4	atm mcpt-timers timer1 timer2 timer3 Example: Device(config-if)# atm mcpt-timers 100 200 300	Sets the Maximum Cell Packing Timeout (MCPT) values in microseconds. <ul style="list-style-type: none"> The MCPT timer sets the time for which the device waits for the raw cells (AAL0 encapsulation) to be packed into a single packet for punting to the pseudowire.
Step 5	exit Example: Device(config-if)# exit	Exits interface configuration mode.
Step 6	configure terminal Example: Device# configure terminal	Enters global configuration mode.
Step 7	interface atm slot/subslot/port.subslot multipoint Example: Device(config)# interface atm 9/1/1.1 multipoint	Enters subinterface configuration mode and creates a multipoint subinterface on the given port on the specified ATM Shared Port Adapter (SPA).
Step 8	no ip address Example: Device(config-subif)# no ip address	Removes the interface IP address.
Step 9	atm enable-ilmi-trap Example: Device(config-subif)# atm enable-ilmi-trap	Generates an Integrated Local Management Interface (ILMI) atmVccChange trap when an ATM interface or subinterface is enabled or shut down.
Step 10	cell-packing maxcells mcpt-timer timer-number Example: Device(config-subif)# cell-packing 20 mcpt-timer 2	Enables ATM over MPLS to pack multiple ATM cells into each MPLS packet within the MCPT timing.

	Command or Action	Purpose
Step 11	xconnect <i>peer-ipaddress</i> <i>vc-id</i> encapsulation mpls Example: Device(config-subif)# xconnect 10.1.1.1 100 encapsulation mpls	(Optional) Enables the attachment circuit and specifies the IP address of the peer, a VC ID, and the data encapsulation method.
Step 12	pvc <i>vpi/vci</i> l2transport Example: Device(config-subif)# pvc 10/100 l2transport	Assigns a VPI and virtual channel identifier (VCI).
Step 13	Repeat Step 12 for the number of PVCs that you want to configure.	—
Step 14	end Example: Device(config-subif)# end	Exits subinterface configuration mode and returns to privileged EXEC mode.

Configuration Examples for N:1 PVC Mapping to PWE with Nonunique VPIs

Example: Configuring N:1 PVC Mapping to PWE with Nonunique VPIs

The following example shows how to configure the N:1 ATM permanent virtual circuit (PVC) mapping to pseudowires with non unique virtual path identifiers (VPIs):

```

Device> enable
Device# configure terminal
Device(config)# interface atm 0/1/0
Device(config-if)# atm mcpt-timers 500 5000 50000
Device(config-if)# exit
Device# configure terminal
Device(config)# interface atm 0/1/0.1 multipoint
Device(config-subif)# no ip address
Device(config-subif)# atm enable-ilmi-trap
Device(config-subif)# cell packing 20 mcpt-timer 2
Device(config-subif)# xconnect 10.1.1.1 100 encapsulation mpls
Device(config-subif)# pvc 10/100 l2transport
Device(config-subif)# pvc 11/122 l2transport
Device(config-subif)# pvc 19/231 l2transport
Device(config-subif)# end

```

Verifying the N:1 PVC Mapping to PWE with Nonunique VPIs Configuration

To verify the N:1 PVC Mapping to PWE with Nonunique VPIs Configuration, use the **show mpls l2transport vc** command in user EXEC or privileged EXEC mode.

```
Router# show mpls l2transport vc
```

```
Local intf      Local circuit          Dest address      VC ID      Status
-----
AT0/1/1.1      ATM CELL ATM0/1/1.1   2.2.2.2          100        UP
```

```
interface ATM0/0/0.1/1/1/1
atm mcpt-timers 20 30 40
```

```
interface ATM0/0/0.1/1/1/1.1 multipoint
no ip address
no atm enable-ilmi-trap
cell-packing 2 mcpt-timer 1
xconnect 2.2.2.2 100 encapsulation mpls
pvc 10/100 l2transport
pvc 20/200 l2transport
pvc 30/300 l2transport
```

Additional References

Related Documents

Related Topic	Document Title
ATM commands	Asynchronous Transfer Mode Command Reference

Technical Assistance

Description	Link
The Cisco Support and Documentation website provides online resources to download documentation, software, and tools. Use these resources to install and configure the software and to troubleshoot and resolve technical issues with Cisco products and technologies. Access to most tools on the Cisco Support and Documentation website requires a Cisco.com user ID and password.	http://www.cisco.com/cisco/web/support/index.html



CHAPTER 10

Pseudowire Group Switchover

The Pseudowire Group Switchover feature allows all pseudowires in a group to be quickly switched over to backup pseudowires. This group switchover is triggered by a single “group down” status message received from a remote peer.

- [Finding Feature Information](#), on page 189
- [Prerequisites for Pseudowire Group Switchover](#), on page 189
- [Restrictions for Pseudowire Group Switchover](#), on page 190
- [Information About Pseudowire Group Switchover](#), on page 190
- [How to Configure Predictive Switchover](#), on page 191
- [Verifying a Pseudowire Group Switchover Configuration](#), on page 192
- [Troubleshooting a Pseudowire Group Switchover Configuration](#), on page 194
- [Configuration Examples for Predictive Switchover](#), on page 194
- [Additional References](#), on page 194
- [Feature Information for Pseudowire Group Switchover](#), on page 195

Finding Feature Information

Your software release may not support all the features documented in this module. For the latest caveats and feature information, see [Bug Search Tool](#) and the release notes for your platform and software release. To find information about the features documented in this module, and to see a list of the releases in which each feature is supported, see the feature information table.

Use Cisco Feature Navigator to find information about platform support and Cisco software image support. To access Cisco Feature Navigator, go to <https://cfngn.cisco.com/>. An account on Cisco.com is not required.

Prerequisites for Pseudowire Group Switchover

- The remote provider edge (PE) router must be capable of sending group status messages.
- Label Distribution Protocol (LDP) must be implemented on the network.
- Each xconnect must have a backup pseudowire configured.

Restrictions for Pseudowire Group Switchover

This feature is supported on the following attachment circuits:

- Ethernet VLAN
- Asynchronous Transfer Mode (ATM)
- Circuit Emulation (CEM) over MPLS
- The pseudowire group switch over convergence number increments linearly with thousand virtual circuits taking 16 seconds of convergence time.

Information About Pseudowire Group Switchover

Introduction to Pseudowire Group Switchover

The Pseudowire Group Switchover feature allows you to reduce the switchover time from main pseudowires to backup pseudowires when a fault is encountered. The reduced switchover time is achieved by grouping Label Distribution Protocol (LDP) status messages and internal interprocess communication (IPC) messages.

When the remote peer detects an attachment circuit failure, it sends an LDP status message. When this status message is received, the designated backup pseudowires take over. Packets are then routed through the backup pseudowires.

Pseudowires can be grouped together by assigning a group ID. When an LDP status message is received by a pseudowire group, the entire group switches over, thus reducing switchover time.



Note The Pseudowire Group Switchover feature is enabled by default and cannot be disabled.

Figure 14: Primary and Backup Pseudowire Groups

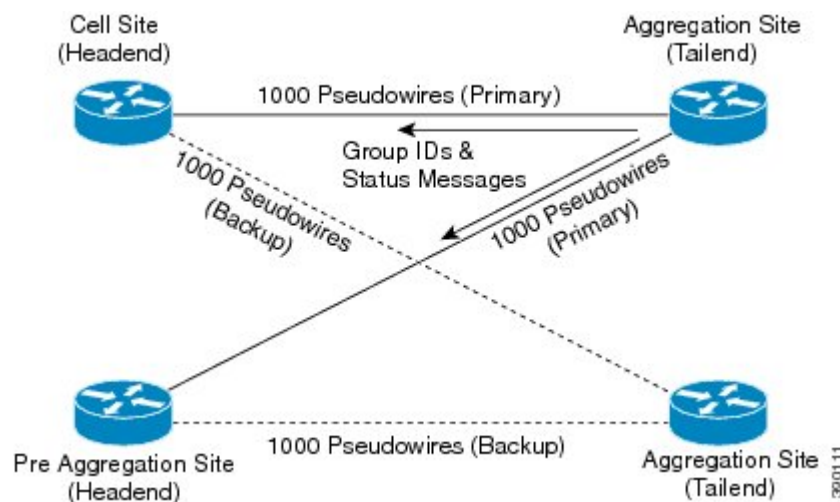

How to Configure Predictive Switchover

Predictive switchover allows switchovers from a main pseudowire to a backup pseudowire with a remote "standby" status, without waiting for an "up" status from the remote peer.

Predictive switchover is configured by enabling redundancy predictive mode in global configuration mode or xconnect configuration mode.

Configuring Predictive Switchover (Global Configuration Mode)

Procedure

	Command or Action	Purpose
Step 1	enable Example: Device> enable	Enables privileged EXEC mode. <ul style="list-style-type: none">• Enter your password if prompted.
Step 2	configure terminal Example: Device# configure terminal	Enters global configuration mode.
Step 3	l2vpn Example: Device(config)# l2vpn	Enters l2vpn configuration mode.
Step 4	redundancy predictive enabled Example: Device(config-l2vpn)# redundancy predictive enabled	Enables redundancy predictive mode. <ul style="list-style-type: none">• By default, redundancy predictive mode is disabled.
Step 5	end Example: Device(config-l2vpn)# end	Exits l2vpn configuration mode and returns to privileged EXEC mode.

Configuring Predictive Switchover (Xconnect Configuration Mode)

Procedure

	Command or Action	Purpose
Step 1	enable Example: Device> enable	Enables privileged EXEC mode. <ul style="list-style-type: none">• Enter your password if prompted.

	Command or Action	Purpose
Step 2	configure terminal Example: Device# configure terminal	Enters global configuration mode.
Step 3	l2vpn xconnect context context-name Example: Device(config)# l2vpn xconnect context con1	Creates an L2VPN cross-connect context and enters xconnect configuration mode.
Step 4	redundancy predictive enabled Example: Device(config-xconnect)# redundancy predictive enabled	Enables redundancy predictive mode.
Step 5	end Example: Device(config-xconnect)# end	Exits xconnect configuration mode and returns to privileged EXEC mode.

Verifying a Pseudowire Group Switchover Configuration

You can use **show** commands to view information about a pseudowire group switchover configuration.

The following example shows how to display information about Any Transport over MPLS (AToM) virtual circuits (VCs):

```
Device# show l2vpn atom vc destination 2.1.1.2 group remote 6
```

Interface	Dest Address	VC ID	Service		Status
			Type	Name	
pw100001	2.1.1.2	1234000	p2p	Et1/0.1-1001	UP

The following example shows how to display the status of the pseudowire switching point:

```
Device# show l2vpn atom vc destination 2.1.1.2 group remote 6 detail
```

```
pseudowire100001 is up, VC status is up PW type: Ethernet
  Create time: 5d20h, last status change time: 5d20h
  Last label FSM state change time: 5d20h
  Destination address: 2.1.1.2 VC ID: 1234000
  Output interface: Et0/0, imposed label stack {2001}
  Preferred path: not configured
  Default path: active
  Next hop: 20.0.0.2
Member of xconnect service Et1/0.1-1001, group right
  Associated member Et1/0.1 is up, status is up
  Interworking type is Ethernet
  Service id: 0x6d000002
Signaling protocol: LDP, peer 2.1.1.2:0 up
  Targeted Hello: 10.1.1.1(LDP Id) -> 2.1.1.2, LDP is UP
  Graceful restart: not configured and not enabled
  Non stop routing: not configured and not enabled
  PWid FEC (128), VC ID: 1234000
```

```

Status TLV support (local/remote) : enabled/supported
LDP route watch : enabled
Label/status state machine : established, LruRru
Local dataplane status received : No fault
BFD dataplane status received : Not sent
BFD peer monitor status received : No fault
Status received from access circuit : No fault
Status sent to access circuit : No fault
Status received from pseudowire i/f : No fault
Status sent to network peer : No fault
Status received from network peer : No fault
Adjacency status of remote peer : No fault
Sequencing: receive disabled, send disabled
Bindings
Parameter      Local                               Remote
-----
Label          2007                               2001
Group ID       0                                   6
Interface
MTU            1500                               1500
Control word on (configured: autosense) on
PW type        Ethernet                            Ethernet
VCCV CV type 0x12                               0x12
               LSPV [2], BFD/Raw [5]             LSPV [2], BFD/Raw [5]
VCCV CC type 0x07                               0x07
               CW [1], RA [2], TTL [3]           CW [1], RA [2], TTL [3]
Status TLV     enabled                             supported
Dataplane:
  SSM segment/switch IDs: 12309/4115 (used), PWID: 1
Rx Counters
  106563 input transit packets, 9803650 bytes
  0 drops, 0 seq err
Tx Counters
  0 output transit packets, 0 bytes
  0 drops

```

The following example lists the active and standby segment pairs associated with each peer IP address and group identifier:

```

Device# show ssm group

Active          Standby
IP Address      Group ID       Segment/Switch Segment/Switch
=====
2.1.1.2         6              8215/4115      4116/8210

```

The following example displays the number of active and standby segment pairs associated with each peer IP address and group identifier:

```

Device# show ssm group 2.1.1.2 6 summary

IP Address      Group ID       Group Members
=====
2.1.1.2         6              1

```

The following example displays the number of pseudowires programmed in the hardware, with grouping information:

```

Device# show platform hardware pp active pw eompls group brief

Brief L2VPN EoMPLS Pseudo Wire Group Info

IP address      Group ID       Count
-----
0x47474747      100695488     90

```

Troubleshooting a Pseudowire Group Switchover Configuration

Use the `debug platform software atom brief` command to view information about the following configurations:

- Add Group
- Delete From Group
- Group Switchovers



Note We recommend that you use the `debug platform software atom brief` command only under Cisco Technical Assistance Center (TAC) supervision.

Configuration Examples for Predictive Switchover

Example: Configuring Predictive Switchover (Global Configuration Mode)

```
Device> enable
Device# configure terminal
Device(config)# l2vpn
Device(config-l2vpn)# redundancy predictive enabled
Device(config-l2vpn)# end
```

Example: Configuring Predictive Switchover (Xconnect Configuration Mode)

```
Device> enable
Device# configure terminal
Device(config)# l2vpn xconnect context con1
Device(config-xconnect)# redundancy predictive enabled
Device(config-xconnect)# end
```

Additional References

Related Documents

Related Topic	Document Title
Cisco IOS commands	Cisco IOS Master Command List, All Releases
MPLS commands	Cisco IOS Multiprotocol Label Switching Command Reference

Standards and RFCs

Standard/RFC	Title
RFC 4447	<i>Pseudowire Setup and Maintenance Using the Label Distribution Protocol (LDP)</i>

Technical Assistance

Description	Link
The Cisco Support and Documentation website provides online resources to download documentation, software, and tools. Use these resources to install and configure the software and to troubleshoot and resolve technical issues with Cisco products and technologies. Access to most tools on the Cisco Support and Documentation website requires a Cisco.com user ID and password.	http://www.cisco.com/cisco/web/support/index.html

Feature Information for Pseudowire Group Switchover

The following table provides release information about the feature or features described in this module. This table lists only the software release that introduced support for a given feature in a given software release train. Unless noted otherwise, subsequent releases of that software release train also support that feature.

Use Cisco Feature Navigator to find information about platform support and Cisco software image support. To access Cisco Feature Navigator, go to www.cisco.com/go/cfn. An account on Cisco.com is not required.

Table 14: Feature Information for Pseudowire Group Switchover

Feature Name	Releases	Feature Information
Pseudowire Group Switchover	Cisco IOS XE Release 3.13.0S	This feature was introduced on the Cisco ASR 920 Routers (ASR-920-12CZ-A, ASR-920-12CZ-D, ASR-920-4SZ-A, ASR-920-4SZ-D).



CHAPTER 11

Configuring Routed Pseudowire and VPLS

Routed Pseudowire and VPLS feature routes Layer 3 traffic and Layer 2 frames for pseudowire connections between provider edge (PE) devices using Virtual Private LAN Services (VPLS) multipoint PE.

- [Prerequisites for Routed Pseudowire and VPLS, on page 197](#)
- [Restrictions for Routed Pseudowire and VPLS, on page 197](#)
- [Information About Routed Pseudowire and VPLS, on page 198](#)
- [How to Configure Routed Pseudowire and VPLS, on page 198](#)
- [Configuration Examples: Routed Pseudowire and VPLS, on page 200](#)

Prerequisites for Routed Pseudowire and VPLS

- MTU must be manually configured for MPLS enabled interfaces.

Restrictions for Routed Pseudowire and VPLS

- MPLS is *not* supported over routed VPLS in releases prior to Cisco IOS XE 16.6.1
- Maximum number of routed VPLS supported per system is 128.
- Maximum number of pseudowires supported per bridge domain is 62.
- Layer 2 and Layer 3 multicast are *not* supported.
- ACL on the core network is *not* supported.
- PBR is *not* supported.
- MTU check is *not* supported. MTU must be manually configured for MPLS enabled interfaces.

Information About Routed Pseudowire and VPLS

Routed Pseudowire and VPLS

Routed Pseudowire and VPLS configuration can route Layer 3 traffic as well as Layer 2 frames for pseudowire connections between provider edge (PE) devices using Virtual Private LAN Services (VPLS) multipoint PE. The ability to route frames to and from these interfaces supports termination of pseudowires into the Layer 3 network (VPN or global) on the same switch, or to the tunnel Layer 3 frames over a Layer 2 tunnel (VPLS).

To configure routing support for a pseudowire, configure the IP address and other Layer 3 features for the Layer 3 domain in interface configuration mode.



Note BFD over BDI is supported with routed VPLS configuration.

How to Configure Routed Pseudowire and VPLS

Assigning IP Addresses For Bridge Domain (BDI)

Procedure

	Command or Action	Purpose
Step 1	enable Example: Device> enable	Enables privileged EXEC mode. <ul style="list-style-type: none"> • Enter your password if prompted.
Step 2	configure terminal Example: Device# configure terminal	Enters global configuration mode.
Step 3	interface bdi <i>bdi-number</i> Example: Router(config)# interface bdi 3000	Configures the bridge domain interface.
Step 4	ip address <i>ip address subnet mask</i> Example: Router(config-if)# ip address 24.24.24.24 255.255.255.0	Specifies the IP address for the bridge domain.

	Command or Action	Purpose
Step 5	no shut Example: Router(config-if)# no shutdown	Enables the bridge domain interface.
Step 6	end Example: Router(config-if)# end	Exits interface configuration mode.

Configuring a VFI on a PE Device

The virtual forwarding interface (VFI) specifies the VPN ID of a Virtual Private LAN Services (VPLS) domain, the addresses of other provider edge (PE) devices in the domain, and the type of tunnel signaling and encapsulation mechanism for each peer. Perform this task to configure a VFI:



Note Only Multiprotocol Label Switching (MPLS) encapsulation is supported.



Note You must configure BDI on the bridge domain that has the association with the VFI.

Procedure

	Command or Action	Purpose
Step 1	enable Example: Device> enable	Enables privileged EXEC mode. <ul style="list-style-type: none"> • Enter your password if prompted.
Step 2	configure terminal Example: Device# configure terminal	Enters global configuration mode.
Step 3	l2 vfi name manual Example: Device(config)# l2 vfi vfi110 manual	Establishes a Layer 2 VPN (L2VPN) virtual forwarding interface (VFI) between two or more separate networks and enters VFI configuration mode.
Step 4	vpn id vpn-id Example: Device(config-vfi)# vpn id 110	Configures a VPN ID for a VPLS domain. <ul style="list-style-type: none"> • The emulated VCs bound to this Layer 2 virtual routing and forwarding (VRF) instance use this VPN ID for signaling.

	Command or Action	Purpose
Step 5	<p>neighbor <i>remote-router-id</i> <i>vc-id</i> {encapsulation <i>encapsulation-type</i> pw-class <i>pw-name</i>} [no-split-horizon]</p> <p>Example:</p> <pre>Device(config-vfi)# neighbor 172.16.10.2 4 encapsulation mpls</pre>	<p>Specifies the type of tunnel signaling and encapsulation mechanism for each VPLS peer.</p> <p>Note Split horizon is the default configuration to avoid broadcast packet looping and to isolate Layer 2 traffic. Use the no-split-horizon keyword to disable split horizon and to configure multiple VCs per spoke into the same VFI.</p>
Step 6	<p>bridge-domain <i>bd-id</i></p> <p>Example:</p> <pre>Device(config-vfi)# bridge-domain 100</pre>	Specifies a bridge domain.
Step 7	<p>end</p> <p>Example:</p> <pre>Device(config-vfi)# end</pre>	Exits VFI configuration mode and returns to privileged EXEC mode.

Configuration Examples: Routed Pseudowire and VPLS

Example: Configuring Routed Pseudowire and VPLS

The example configures the IP address on a BDI interface and associates the interface to a VFI.

```
!
interface GigabitEthernet0/0/0
 service instance 3 ethernet
 encapsulation dot1q 3000
 rewrite ingress tag pop 1 symmetric
 bridge-domain 100
!
interface BDI100
 ip address 24.24.24.24 255.255.255.0
 no shut
!
12 vfi TEST manual
 vpn id 100
 bridge-domain 100
 neighbor 9.9.9.9 encapsulation mpls
!
```



CHAPTER 12

VPLS over Backup Pseudowire

Pseudowire redundancy allows you to detect any failure in the network and reroute the Layer 2 service to another endpoint. The other endpoint can continue to provide this service by providing additional backup pseudowire. This feature provides the ability to recover from a failure of either the remote provider edge (PE) router or the link between the PE and customer edge (CE) routers.

L2VPNs can provide pseudowire resiliency through their routing protocols. When the connectivity between the end-to-end PE routers fails, an alternative path to the directed LDP session and the user data takes over. However, there are some parts of the network in which this rerouting mechanism does not protect against interruptions in service.

RSP3 implementation reuses the EoMPLS configuration to achieve VPLS over the backup pseudowire functionality. The expected convergence in virtual circuit switchover and fallback is approximately 200-300 ms, which increases with scale configuration because only active pseudowire is programmed in hardware.

These are some scenarios in which pseudowire switchover takes place:

- Core link flap
- Access link flap
- Default access interface
- Remote loopback interface flap
- LDP disable or enable
- Control Word change
- VPN ID change within pseudowire configuration
- Cable pull
- Core side interface module reload
- Core side BFD flap (if configured)
- Core side IGP down
- Remote PE or P node reload or crash

Figure 15: Sample Topology for VPLS over Backup Pseudowire Deployment Scenario

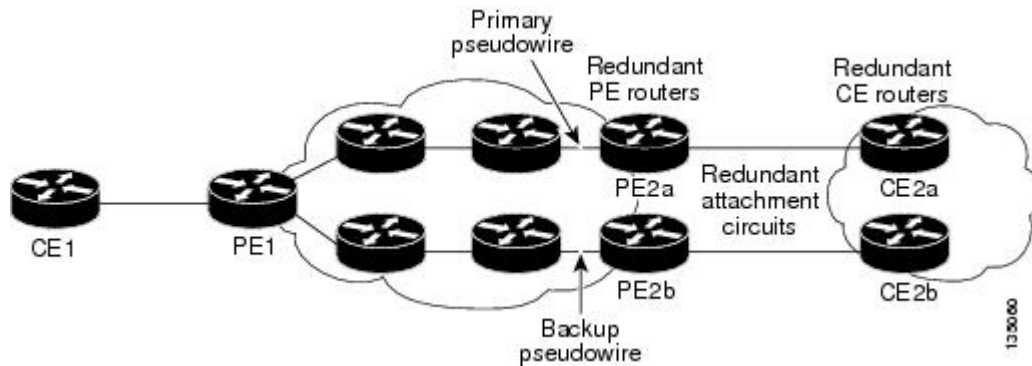

- [Prerequisites for VPLS over Backup Pseudowire, on page 202](#)
- [Restrictions for VPLS over Backup Pseudowire , on page 202](#)
- [Convergence Time for the VPLS Sessions, on page 203](#)
- [VPLS over Backup Pseudowire Configuration, on page 203](#)
- [Verify VPLS over Backup Pseudowire Configuration , on page 205](#)

Prerequisites for VPLS over Backup Pseudowire

- IGP and LDP should be up and running between peer devices.
- MTU must be manually configured for MPLS enabled interfaces.

Restrictions for VPLS over Backup Pseudowire

- Only one active and one backup pseudowire (PW) for each bridge domain (BD) is supported.
- Hierarchical Virtual Private Lan Service (HVPLS) is not supported.
- VPLS with BGP auto discovery is not supported.
- 1000 active PW with one backup PW for each VPLS session is supported.
- This feature is supported only with the new VPLS configuration model (on all the PE nodes).
- VFI's configured with the old configuration model cannot coexist with the VFI's of the new configuration model on the same BD.
- The member BDI should not be in the same group as the PW under l2vpn xconnect context configuration.
- More than two PW should not be configured in L2VPN context.
- In an L2VPN cross-connect context, the member BDI and the member physical interface cannot be configured at the same time. It leads to error objects.
- The maximum scale for VPLS session is 1000.
- The BDI used for this feature should not be configured with any IP configuration like MPLS IP, DHCP IP, or static IP.

- Routed PW cannot be configured because BDI interface cannot be configured with IP address.

Convergence Time for the VPLS Sessions

Table 15: Convergence Time (in Milliseconds) with One VPLS Session

Packet Size (Bytes)	Convergence Time (approximate)	Type Of Packet
64	213	IP
128	186	IP
256	173	IP
512	170	IP
1028	186	IP
1400	167	IP

Table 16: Convergence Time (in Milliseconds) with Multiple VPLS Session

Number of Virtual Circuits	Scenario	Convergence Time (approximate)
10	Active Down	373.56
	Reoptimization	15.73
100	Active Down	1880
	Reoptimization	517.93

VPLS over Backup Pseudowire Configuration

The following example shows the configuration on provider edge (PE) router 1 having two links to PE router 2 with IP address 209.165.200.225 and PE router 3 with IP address 209.165.200.226:

Configuration on PE router 1:

```
interface GigabitEthernet0/2/3
  no ip address
  negotiation auto
  service instance 1 ethernet
    encapsulation dot1q 1
    rewrite ingress tag pop 1 symmetric
!
bridge-domain 1000
  member GigabitEthernet0/2/3 service-instance 1
!
interface pseudowire10
  encapsulation mpls
  neighbor 209.165.200.225 1000
!
```

```

interface pseudowire20
  encapsulation mpls
  neighbor 209.165.200.226 2000
!
interface BDI1000
  no ip address
!
l2vpn xconnect context VC_1
  member BDI1000
  member pseudowire10 group Grp_1 priority 1
  member pseudowire20 group Grp_1 priority 2

```

Configuration on PE router 2:

```

interface GigabitEthernet0/2/4
  no ip address
  carrier-delay msec 0
  negotiation auto
  service instance 1 ethernet
    encapsulation dot1q 1
    rewrite ingress tag pop 1 symmetric!
bridge-domain 1
  member GigabitEthernet0/2/4 service-instance 1
!
interface pseudowire10
  encapsulation mpls
  neighbor 209.165.200.224 10
!
interface BDI1
  no ip address
!
l2vpn xconnect context VC_1
  member BDI1
  member pseudowire10 group Grp_1 priority 1

```

Configuration on PE router 3:

```

interface GigabitEthernet0/2/0
  no ip address
  carrier-delay msec 0
  negotiation auto
  service instance 1 ethernet
    encapsulation dot1q 1
    rewrite ingress tag pop 1 symmetric
!
bridge-domain 1
  member GigabitEthernet0/2/0 service-instance 1
!
interface pseudowire10
  encapsulation mpls
  neighbor 209.165.200.224 20
!
interface BDI1
  no ip address
!
l2vpn xconnect context VC_1
  member BDI1
  member pseudowire10 group Grp_1 priority 1

```

Verify VPLS over Backup Pseudowire Configuration

Use the following commands to verify the VPLS over backup pseudowire configuration on the PE router 1 head node:

```
PE1#show mpls l2transport vc
Local intf      Local circuit      Dest address      VC ID      Status
-----
BD1000          Eth VLAN 1000      209.165.200.225  1000       UP
BD1000          Eth VLAN 1000      209.165.200.226  2000       STANDBY
```

```
PE1#show mpls l2transport vc 1000 detail
Local interface: BD1000 up, line protocol up, Eth VLAN 1000 up
Interworking type is Ethernet
Destination address: 209.165.200.225, VC ID: 1000, VC status: up
Output interface: Gi0/2/5, imposed label stack {24 24}
Preferred path: not configured
Default path: active
Next hop: 192.168.1.2
Create time: 00:08:46, last status change time: 00:07:14
Last label FSM state change time: 00:07:12
Signaling protocol: LDP, peer 209.165.200.225:0 up
Targeted Hello: 209.165.200.227(LDP Id) -> 209.165.200.225, LDP is UP
Graceful restart: configured and enabled
Non stop routing: configured and enabled
Status TLV support (local/remote) : enabled/supported
LDP route watch : enabled
Label/status state machine : established, LruRru
Last local dataplane status rcvd: No fault
Last BFD dataplane status rcvd: Not sent
Last BFD peer monitor status rcvd: No fault
Last local AC circuit status rcvd: No fault
Last local AC circuit status sent: No fault
Last local PW i/f circ status rcvd: No fault
Last local LDP TLV status sent: No fault
Last remote LDP TLV status rcvd: No fault
Last remote LDP ADJ status rcvd: No fault
MPLS VC labels: local 24, remote 24
Group ID: local n/a, remote 0
MTU: local 1500, remote 1500
Remote interface description:
Sequencing: receive disabled, send disabled
Control Word: On (configured: autosense)
SSO Descriptor: 209.165.200.225/1000, local label: 24
Dataplane:
SSM segment/switch IDs: 4186/4180 (used), PWID: 6
VC statistics:
transit packet totals: receive 0, send 0
transit byte totals: receive 0, send 0
transit packet drops: receive 0, seq error 0, send 0
```

```
PE1#show mpls l2transport vc 2000 detail
Local interface: BD1000 up, line protocol up, Eth VLAN 1000 up
Interworking type is Ethernet
Destination address: 209.165.200.226, VC ID: 2000, VC status: standby
Output interface: Gi0/2/1, imposed label stack {21 16}
Preferred path: not configured
Default path: active
Next hop: 192.168.3.2
Create time: 00:08:51, last status change time: 00:08:51
```

```

Last label FSM state change time: 00:05:40
Signaling protocol: LDP, peer 209.165.200.226:0 up
Targeted Hello: 209.165.200.227(LDP Id) -> 209.165.200.226, LDP is UP
Graceful restart: configured and enabled
Non stop routing: configured and enabled
Status TLV support (local/remote)   : enabled/supported
  LDP route watch                    : enabled
  Label/status state machine         : established, LrdRru
  Last local dataplane               status rcvd: No fault
  Last BFD dataplane                 status rcvd: Not sent
  Last BFD peer monitor               status rcvd: No fault
  Last local AC circuit               status rcvd: DOWN(standby)
  Last local AC circuit               status sent: No fault
  Last local PW i/f circuit           status rcvd: No fault
  Last local LDP TLV                  status sent: DOWN(standby)
  Last remote LDP TLV                 status rcvd: No fault
  Last remote LDP ADJ                 status rcvd: No fault
MPLS VC labels: local 25, remote 16
Group ID: local n/a, remote 0
MTU: local 1500, remote 1500
Remote interface description:
Sequencing: receive disabled, send disabled
Control Word: On (configured: autosense)
SSO Descriptor: 209.165.200.226/2000, local label: 25
Dataplane:
  SSM segment/switch IDs: 12382/8277 (used), PWID: 7
VC statistics:
  transit packet totals: receive 0, send 0
  transit byte totals:  receive 0, send 0
  transit packet drops:  receive 0, seq error 0, send 0

```

PE1#show bridge-domain 1000

```

Bridge-domain 1000 (3 ports in all)
State: UP                               Mac learning: Enabled
Aging-Timer: 300 second(s)
Maximum address limit: 65534
  BDI1000 (up)
  GigabitEthernet0/2/3 service instance 1
  BDI1000 service instance 1

```

PE1#show l2vpn service all detail

```

Legend: St=State      XC St=State in the L2VPN Service      Prio=Priority
         UP=Up        DN=Down                               IA=Inactive
         SB=Standby  HS=Hot Standby                       RV=Recovering
         m=manually selected                               NH=No Hardware

```

Interface	Group	Encapsulation	Prio	St	XC	St
-----	----	-----	----	--	----	-----
VPWS name: VC_1, State: UP						
pw1000	Grp_1	209.165.200.225:1000 (MPLS)		1	UP	UP
		Local VC label 24				
		Remote VC label 24				
pw2000	Grp_1	209.165.200.226:2000 (MPLS)		2	SB	IA
		Local VC label 25				
		Remote VC label 16				
BD1000		BD1000:1000 (Eth VLAN)	0	UP	UP	
		Interworking: ethernet				

PE1#show l2vpn service all

```

Legend: St=State      XC St=State in the L2VPN Service      Prio=Priority
        UP=Up         DN=Down                             AD=Admin Down      IA=Inactive
        SB=Standby    HS=Hot Standby                     RV=Recovering      NH=No Hardware
        m=manually selected

```

Interface	Group	Encapsulation	Prio	St	XC	St
-----	-----	-----	----	--	-----	-----
VPWS name: VC_1, State: UP						
pw1000	Grp_1	209.165.200.225:1000 (MPLS)			1	UP UP
pw2000	Grp_1	209.165.200.226:2000 (MPLS)			2	SB IA
BD1000		BD1000:1000 (Eth VLAN)	0	UP		UP



CHAPTER 13

VPLS Configuration over MPLS-TP

This chapter describes how to configure VPLS over MPLS-TP and includes the following sections:

For more information, see the [MPLS Transport Profile](#).

- [VPLS over MPLS-TP, on page 209](#)
- [Configuring VPLS over MPLS-TP, on page 210](#)
- [Verifying the Configuration, on page 220](#)
- [Configuration Examples, on page 221](#)
- [Feature Information for VPLS Configuration over MPLS-TP, on page 222](#)

VPLS over MPLS-TP

The sections below provide an overview of VPLS over MPLS-TP:

Multiprotocol Label Switching Overview

The Multiprotocol Label Switching (MPLS) Transport Profile (TP) enables you to create tunnels that provide the transport network service layer over which IP and MPLS traffic traverse. MPLS-TP tunnels enable a transition from Synchronous Optical Networking (SONET) and Synchronous Digital Hierarchy (SDH) time-division multiplexing (TDM) technologies to packet switching to support services with high bandwidth requirements, such as video.

Virtual Private LAN Services Overview

uses the provider core to join multiple attachment circuits together to simulate a virtual bridge that connects the multiple attachment circuits together. From a customer point of view, there is no topology for VPLS. All of the CE devices appear to connect to a logical bridge emulated by the provider core. See figure below.

VPLS over MPLS-TP Overview

VPLS over MPLS-TP allows you to deploy a multipoint-to-multipoint layer 2 operating environment over an MPLS-TP network for services such as Ethernet connectivity and multicast video.

References

For detailed information about the commands, see:

- Cisco IOS XE 3.5 MPLS Command Reference:
http://www.cisco.com/en/US/docs/ios/cether/command/reference/ce_book.html
- Master Command Index for Cisco IOS XE Release 3.5:
http://www.cisco.com/en/US/docs/ios/mcl/allreleasemcl/all_book.html

Configuring VPLS over MPLS-TP

The sections below describe how to configure VPLS over MPLS-TP:

Configuration Guidelines

VPLS over MPLS-TP is only supported on Gigabit Ethernet and Ten Gigabit Ethernet interfaces.

Configuring the MPLS Label Range

You must specify a static range of MPLS labels using the **mpls label range** command with the **static** keyword.

Procedure

	Command or Action	Purpose
Step 1	enable Example: Router> enable	Enables privileged EXEC mode. • Enter your password if prompted.
Step 2	configure terminal Example: Router# configure terminal	Enters global configuration mode.
Step 3	mpls label range <i>minimum-value</i> <i>maximum-value</i> { static <i>minimum-static-value</i> <i>maximum-static-value</i> } Example: Router(config)# mpls label range 1001 1003 static 10000 25000	Specifies a static range of MPLS labels

Configuring the Router ID and Global ID

Procedure

	Command or Action	Purpose
Step 1	enable Example: Router> enable	Enables privileged EXEC mode. <ul style="list-style-type: none">• Enter your password if prompted.
Step 2	configure terminal Example: Router# configure terminal	Enters global configuration mode.
Step 3	mpls tp Example: Router(config)# mpls tp	Enters MPLS-TP configuration mode, from which you can configure MPLS-TP parameters for the router.
Step 4	router-id <i>node-id</i> Example: Router(config-mpls-tp)# router-id 10.10.10.10	Specifies the default MPLS-TP router ID, which is used as the default source node ID for all MPLS-TP tunnels configured on the router.
Step 5	global-id <i>num</i> Example: Router(config-mpls-tp)# global-id 1	(Optional) Specifies the default global ID used for all endpoints and midpoints. This command makes the router ID globally unique in a multiprovider tunnel. Otherwise, the router ID is only locally meaningful. The global ID is an autonomous system number, which is a controlled number space by which providers can identify each other. The router ID and global ID are also included in fault messages by routers at tunnel midpoints to help isolate the location of faults.

Configuring the Pseudowire Class

When you create the pseudowire class, you specify the parameters of the pseudowire, such as the use of the control word, and preferred path.

Procedure

	Command or Action	Purpose
Step 1	enable Example: Router> enable	Enables privileged EXEC mode. <ul style="list-style-type: none">• Enter your password if prompted.

	Command or Action	Purpose
Step 2	configure terminal Example: Router# configure terminal	Enters global configuration mode.
Step 3	pseudowire-class <i>class-name</i> Example: Router(config)# pseudowire-class mpls-tp-class1	Creates a pseudowire class and enters pseudowire class configuration mode.
Step 4	encapsulation mpls Example: router(config-pw-class)# encapsulation mpls	Specifies the encapsulation type.
Step 5	control-word Example: Router(config-pw-class)# control-word	Enables the use of the control word.
Step 6	protocol {l2tpv2 l2tpv3 none}[l2tp-class-name] Example: Router(config-pw-class)# protocol none	Specifies the type of protocol.
Step 7	preferred-path {interface tunnel tunnel-number peer {ip-address host-name}} [disable-fallback] Example: Router(config-pw-class)# preferred-path interface tunnel-tp2	Specifies the tunnel to use as the preferred path.
Step 8	end Example: Router(config-pw-class)# end Router#	Exits configuration mode.

Configuring a BFD Template

Procedure

	Command or Action	Purpose
Step 1	enable Example: Router> enable	Enables privileged EXEC mode. <ul style="list-style-type: none"> • Enter your password if prompted.

	Command or Action	Purpose
Step 2	configure terminal Example: Router# configure terminal	Enters global configuration mode.
Step 3	bfd-template single-hop <i>template-name</i> Example: Router(config)# bfd-template single-hop bfdtemplate1	Creates a BFD template and enters BFD configuration mode. The bfd-template command allows you to create a BFD template and enters BFD configuration mode. The template can be used to specify a set of BFD interval values. You can then invoke the BFD template when you set up the MPLS-TP tunnel.
Step 4	interval microseconds {both microseconds / min-tx microseconds min-rx microseconds} [multiplier multiplier-value] Example: Router(config-bfd)# interval microseconds both 3300 multiplier 3	Configures the transmit and receive intervals in microseconds between BFD packets, and specifies the number of consecutive BFD control packets that must be missed from a BFD peer before BFD declares that a peer is unavailable.
Step 5	interval {both milliseconds / min-tx milliseconds min-rx milliseconds} [multiplier multiplier-value] Example: Router(config-bfd)# interval both 120 multiplier 3	Configures the transmit and receive intervals in milliseconds between BFD packets, and specifies the number of consecutive BFD control packets that must be missed from a BFD peer before BFD declares that a peer is unavailable.
Step 6	end Example: Router(config-bfd)# end Router#	Exits configuration mode.

Configuring the MPLS-TP Tunnel

On the endpoint routers, create an MPLS TP tunnel and configure its parameters. See the **interface tunnel-tp** command for information on the parameters.

Procedure

	Command or Action	Purpose
Step 1	enable Example: Router> enable	Enables privileged EXEC mode. • Enter your password if prompted.

	Command or Action	Purpose
Step 2	configure terminal Example: Router# configure terminal	Enters global configuration mode.
Step 3	interface tunnel-tp <i>number</i> Example: Router(config)# interface tunnel-tp 2	Enters tunnel interface configuration mode. Tunnel numbers from 0 to 999 are supported.
Step 4	description tunnel-description Example: Router(config-if)# description headend tunnel	(Optional) Specifies a tunnel description.
Step 5	tp tunnel-name <i>name</i> Example: Router(config-if)# tp tunnel-name tunnel22	Specifies the name of the MPLS-TP tunnel. The TP tunnel name is displayed in the show mpls tp tunnel command output. This command is useful for consistently identifying the tunnel at all endpoints and midpoints.
Step 6	tp source <i>node-id [global-id num]</i> Example: Router(config-if)# tp source 10.10.11.11 global-id 10	(Optional) Specifies the tunnel source and endpoint. This command is and not typically used, because the global router ID and global ID can be used to identify the tunnel source at the endpoint. All tunnels on the router generally use the same (globally specified) source information.
Step 7	tp destination <i>node-id [[tunnel-tpnum] global-id num]</i> Example: Router(config-if)# tp destination 10.10.10.10	Specifies the destination node of the tunnel.
Step 8	bfd <i>bfd-template</i> Example: Router(config-if)# bfd template1	Specifies the BFD template.
Step 9	working-lsp Example: Router(config-if)# working-lsp	Specifies a working LSP, also known as the primary LSP. This LSP is used to route traffic. This command enters working LSP interface configuration mode (config-if-working).
Step 10	in-label <i>num</i> Example: Router(config-if-working)# in-label 10000	Specifies the in label.

	Command or Action	Purpose
Step 11	out-label <i>num</i> out-link <i>num</i> Example: <pre>Router(config-if-working)# out-label 10000 out-link 1</pre>	Specifies the out label and out link.
Step 12	exit Example: <pre>Router(config-if-working)# exit</pre>	Exits from working LSP interface configuration mode.
Step 13	protect-lsp Example: <pre>Router(config-if)# protect-lsp</pre>	Specifies a backup for a working LSP. If the working LSP fails, traffic is switched to the protect LSP until the working LSP is restored, at which time forwarding reverts back to the working LSP. This command enters protect LSP interface configuration mode (config-if-protect).
Step 14	in-label <i>num</i> Example: <pre>Router(config-if-protect)# in-label 10001</pre>	Specifies the in label.
Step 15	out-label <i>num</i> out-link <i>num</i> Example: <pre>Router(config-if-protect)# out-label 10001 out-link 2</pre>	Specifies the out label and out link.
Step 16	exit Example: <pre>Router(config-if-protect)# exit</pre>	Exits from protect LSP interface configuration mode.

Configuring MPLS-TP Links and Physical Interfaces

MPLS-TP link numbers may be assigned to physical interfaces only. Bundled interfaces and virtual interfaces are not supported for MPLS-TP link numbers.

The sections below describe how to configure physical interfaces for a VPLS over MPLS-TP link.

Configuring an Output Interface

Procedure

	Command or Action	Purpose
Step 1	enable Example: <pre>Router> enable</pre>	Enables privileged EXEC mode. Enter your password if prompted.

	Command or Action	Purpose
Step 2	configure terminal Example: Router# configure terminal	Enters global configuration mode.
Step 3	interface <i>type/num</i> Example: Router(config)# interface gigabitEthernet 1/0	Specifies the interface and enters interface configuration mode.
Step 4	no ip address Example: Router(config-if)# no ip address	Specifies that there is no IP address assigned to the interface.
Step 5	negotiation auto Example: Router(config-if)# negotiation auto	Enables the autonegotiation protocol to configure the speed, duplex, and automatic flow control of the Gigabit Ethernet interface.
Step 6	mpls tp link <i>link-num</i> { ipv4 <i>ip-address</i> / tx-mac <i>mac-address</i> } Example: Router(config-if)# mpls tp link 1 ipv4 10.0.0.2	Associates an MPLS-TP link number with a physical interface and next-hop node. On point-to-point interfaces or Ethernet interfaces designated as point-to-point using the medium p2p command, the next-hop can be implicit, so the mpls tp link command just associates a link number to the interface. Multiple tunnels and LSPs can refer to the MPLS-TP link to indicate they are traversing that interface. You can move the MPLS-TP link from one interface to another without reconfiguring all the MPLS-TP tunnels and LSPs that refer to the link. Link numbers a must be unique on the router or node.
Step 7	exit Example: Router(config-if)# exit	Exits interface configuration mode.
Step 8	exit Example: Router(config)# exit	Exits global configuration mode.
Step 9	show mpls tp link-numbers Example: Router# show mpls tp link-numbers	Displays the configured links.

Configuring an Access Interface

Procedure

	Command or Action	Purpose
Step 1	enable Example: Router> enable	Enables privileged EXEC mode. <ul style="list-style-type: none">• Enter your password if prompted.
Step 2	configure terminal Example: Router# configure terminal	Enters global configuration mode.
Step 3	interface <i>type/num</i> Example: Router(config)# interface gigabitethernet 1/0	Specifies the interface and enters interface configuration mode.
Step 4	no ip address Example: Router(config-if)# no ip address	Specifies that there is no IP address assigned to the interface.
Step 5	negotiation auto Example: Router(config-if)# negotiation auto	Enables the autonegotiation protocol to configure the speed, duplex, and automatic flow control of the Gigabit Ethernet interface.
Step 6	service instance <i>id service-type</i> Example: Router(config)# service instance 1 ethernet	Configures an Ethernet service instance.
Step 7	encapsulation dot1q <i>vlan-id</i> second-dot1q {any / <i>vlan-id</i> / <i>vlan-id-vlan-id</i> [, <i>vlan-id-vlan-id</i>]} Example: Router(config-if)# encapsulation dot1q 2	Enables IEEE 802.1Q encapsulation of traffic on a specified subinterface in a VLAN.
Step 8	bridge-domain <i>vlan-id</i> [access dot1q [<i>tag</i>] / dot1q-tunnel] [broadcast] [ignore-bpdu-pid] [pvst-tlv <i>CE-vlan</i>] [increment] [lan-fcs] [split-horizon] Example: Router(config-if)# bridge-domain 1000	Places the interface in the same bridge domain as the VFI interface.
Step 9	exit Example: Router(config-if)# exit	Exits interface configuration mode.

Configuring the VFI in the PE

The virtual switch instance (VFI) specifies the VPN ID of a VPLS domain, the addresses of other PE routers in this domain, and the type of tunnel signaling and encapsulation mechanism for each peer. (This is where you create the VSI and associated VCs.) Configure a VFI as follows:



Note Only MPLS encapsulation is supported.

Procedure

	Command or Action	Purpose
Step 1	l2 vfi name manual Example: Router(config)# l2 vfi vfi17 manual	Enables the Layer 2 VFI manual configuration mode.
Step 2	vpn id <i>vpn-id</i> Example: Router(config-vfi)# vpn id 1000	Configures a VPN ID for a VPLS domain. The emulated VCs bound to this Layer 2 VRF use this VPN ID for signaling.
Step 3	bridge-domain <i>vlan-id</i> [access dot1q [<i>tag</i>] / dot1q-tunnel] [broadcast] [ignore-bpdu-pid] [pvst-tlv <i>CE-vlan</i>] [increment] [lan-fcs] [split-horizon] Example: Router(config-vfi)# bridge-domain 1000	Places the VFI in the same bridge domain as the access interface.
Step 4	neighbor <i>remote router id</i> [<i>vc-id-value</i>] {encapsulation mpls} [no-split-horizon] Example: Router(config-vfi)# neighbor 1.5.1.1 101 encapsulation mpls	Specifies the remote peering router ID and the tunnel encapsulation type or the pseudo wire property to be used to set up the emulated VC. Note Split horizon is the default configuration to avoid broadcast packet looping and to isolate Layer 2 traffic. Use the no-split-horizon keyword to disable split horizon and to configure multiple VCs per spoke into the same VFI. Note The optional VC ID value identifies the emulated VC between a pair of peering PE routers.
Step 5	shutdown Example: Router(config-vfi)# shutdown	Disconnects all emulated VCs previously established under the Layer 2 VFI and prevents the establishment of new attachment circuits.

	Command or Action	Purpose
		Note It does not prevent the establishment of new attachment circuits configured with the Layer 2 VFI using CLI.

Configuring a Virtual Loopback Interface

This task explains how to configure a basic loopback interface.

The IP address of a loopback interface must be unique across all routers on the network. It must not be used by another interface on the router, and it must not be used by an interface on any other router on the network.

Procedure

	Command or Action	Purpose
Step 1	configure terminal Example: Router# configure terminal	Enters global configuration mode.
Step 2	interface loopback <i>interface-path-id</i> Example: Router#(config)# interface Loopback 3	Enters interface configuration mode and names the new loopback interface.
Step 3	ipv4 address <i>ip-address</i> Example: Router(config-if)# ipv4 address 172.18.189.38	Assigns an IP address and subnet mask to the virtual loopback interface using the ipv4 address configuration command.
Step 4	end Example: Router(config-if)# end	Saves configuration changes. When you issue the end command, the system prompts you to commit changes: Uncommitted changes found, commit them before exiting(yes/no/cancel)? [cancel]: <ul style="list-style-type: none"> • Entering yes saves configuration changes to the running configuration file, exits the configuration session, and returns the router to EXEC mode. • Entering no exits the configuration session and returns the router to EXEC mode without committing the configuration changes. • Entering cancel leaves the router in the current configuration session without exiting or committing the configuration changes.

	Command or Action	Purpose
		Note Use the commit command to save the configuration changes to the running configuration file and remain within the configuration session.
Step 5	show interfaces <i>type interface-path-id</i> Example: <pre>router# show interfaces Loopback 3</pre>	(Optional) Displays the configuration of the loopback interface.

Verifying the Configuration

You can use the following commands to verify your configuration:

- **show mpls l2transport vc**—Displays information about Any Transport over MPLS (AToM) virtual circuits (VCs) and static pseudowires that have been enabled to route Layer 2 packets on the router.
- **show mpls tp**—Displays information about Multiprotocol Label Switching (MPLS) transport profile (TP) tunnels.
- **show bfd summary**—Displays summary information for Bidirectional Forwarding Protocol (BFD).
- **show xconnect**—Displays information about xconnect attachment circuits and pseudowires.

You can use the following commands to debug your configuration:

- **debug mpls tp all**—Debug for all MPLS-TP information.
- **debug mpls tp cli**—Debug for MPLS-TP CLI
- **debug mpls tp error**—Debug for MPLS-TP errors
- **debug mpls tp event**—Debug for MPLS events
- **debug mpls tp fault-oam**—Debug for Fault-OAM
- **debug mpls tp ha**—Debug for High availability
- **debug mpls tp init**—Debug for MPLS-TP initialization
- **debug mpls tp link-management**—Debug for link management
- **debug mpls tp link-num**—Debug for link number database
- **debug mpls tp lsp-db**—Debug for LSP database
- **debug mpls tp lsp-ep**—Debug for endpoint LSP configuration and operation
- **debug mpls tp lsp-mp**—Debug for midpoint LSP configuration and operation
- **debug mpls tp mem**—Debug for memory allocation and usage
- **debug mpls tp tun-db**—Debug for the tunnel database
- **debug mpls tp tunnel**—Debug for tunnel configuration and operation

Configuration Examples

PE Configuration

```

!
mpls label range 1001 4000 static 16 1000
mpls tp
  router-id 10.10.10.10
!
bfd-template single-hop testbfd
interval microseconds min-tx 50000 min-rx 50000 multiplier 3
!
! Output link
interface GigabitEthernet0/0/0
  no ip address
  negotiation auto
  mpls tp link 2 tx-mac 88f0.7768.2300
!

! Output link
interface GigabitEthernet0/2/0
  no ip address
  negotiation auto
  mpls tp link 1 tx-mac 88f0.7768.2310
!
!
interface Tunnel-tp1
ip unnumbered Loopback0
  no keepalive
  tp source 10.10.10.10 global-id 0
  tp destination 192.168.1.1 global-id 0
  bfd testbfd
  working-lsp
    out-label 100 out-link 1
    in-label 200
    lsp-number 0
  protect-lsp
    out-label 300 out-link 2
    in-label 400
    lsp-number 102
!
!
pseudowire-class myclass
  encapsulation mpls
  preferred-path interface Tunnel-tp1
!
!
!VFI definition
l2 vfi VPLS manual
  vpn id 1000
  bridge-domain 1000
  neighbor 192.168.1.1 pw-class myclass
!
!
interface Loopback0
  ip address 10.10.10.10 255.255.255.255
!
! Access interface
interface GigabitEthernet0/1/0
  no ip address
  negotiation auto

```

```

service instance 1 ethernet
  encapsulation dot1q 2
  bridge-domain 1000
!
```

P Configuration (Midpoint)

```

!
interface loopback 0
ip address 9.9.9.9 255.255.255.255
!
mpls label range 1001 4000 static 16 1000
mpls t
router-id 9.9.9.9
!
mpls tp lsp source 10.10.10.10 tunnel-tp 1 lsp working destination 192.168.1.1 tunnel-tp 1
  forward-lsp
    in-label 100 out-label 300 out-link 1
  reverse-lsp
    in-label 400 out-label 200 out-link 2
!
out-link 1 connected to 192.168.1.1
out-link 2 connected to 10.10.10.10
```

Feature Information for VPLS Configuration over MPLS-TP

The following table provides release information about the feature or features described in this module. This table lists only the software release that introduced support for a given feature in a given software release train. Unless noted otherwise, subsequent releases of that software release train also support that feature.

Use Cisco Feature Navigator to find information about platform support and Cisco software image support. To access Cisco Feature Navigator, go to www.cisco.com/go/cfn. An account on Cisco.com is not required.

Table 17: Feature Information for VPLS Configuration over MPLS-TP

Feature Name	Release	Feature Information
VPLS Configuration over MPLS-TP	IOS XE 3.5	This feature was introduced on the Cisco RSP1 Module in this release.
VPLS Configuration over MPLS-TP	IOS XE 3.13	This feature was introduced on the Cisco RSP2 Module in this release.
VPLS Configuration over MPLS-TP	IOS XE 3.16	This feature was introduced on the Cisco RSP3 Module in this release.
Feature Name	Release	Feature Information
VPLS Configuration over MPLS-TP	IOS XE 3.13	This feature was introduced on the Cisco ASR 920 Series Aggregation Services Router.



CHAPTER 14

EVPN Single-Homing Over MPLS

The EVPN Single-Homing feature utilizes the functionality defined in RFC 7432 (BGP MPLS-based Ethernet VPN), to achieve single-homing between a Provider Edge (PE) and a Customer Edge (CE) device.

- [Feature History, on page 224](#)
- [Information about EVPN Single-Homing, on page 224](#)
- [Prerequisites for EVPN Single-Homing, on page 228](#)
- [Restrictions for EVPN Single-Homing, on page 228](#)
- [How to Configure EVPN Single Homing, on page 229](#)
- [Verification Examples for EVPN Single-Homing, on page 232](#)
- [Additional References for EVPN Single-Homing, on page 237](#)

Feature History

Table 18: Feature History

Feature Name	Release Information	Feature Description
EVPN Single-Homing Over MPLS	Cisco IOS XE Amsterdam 17.3.1	<p>The EVPN Single-Homing feature utilizes the BGP MPLS-based Ethernet VPN functionality as defined in RFC 7432. That is, to achieve single-homing between a Provider Edge (PE) and a Customer Edge (CE) device.</p> <p>There are three fundamental building blocks for EVPN technology, EVPN Instance (EVI), Ethernet Segment (ES), EVPN BGP routes and extended communities.</p> <p>For EVPN Single-Homing feature, a CE device is attached to a single PE device and has an Ethernet Segment.</p> <p>This feature is supported on the Cisco ASR 920 routers.</p>

Information about EVPN Single-Homing

Ethernet Multipoint Connectivity

To achieve Ethernet multipoint connectivity, MPLS deployments traditionally rely on Virtual Private LAN Services (VPLS). A VPLS service is built with a full-mesh of pseudowires between PE devices that are part of a Layer 2 broadcast domain. A VPLS PE device performs data-plane MAC learning. For MAC learning, the VPLS PE device uses local interfaces for traffic coming from the access network and uses pseudowires for the traffic coming from the core network.

EVPN Multipoint Solution

EVPN is the next generation of multipoint L2VPN solution that aligns operation principles of L3VPN with Ethernet services. Instead of relying solely on data plane for MAC Address learning, EVPN PE devices signal and learn MAC addresses over the core network using BGP, while still using data plane MAC-learning on the access side. Providers can configure BGP as a common VPN control plane for their ethernet offerings and leverage the advantages of Layer 3 VPN over VPLS. In Cisco IOS XE Fuji 16.8.1, only Single Homing functionality is supported from the feature set defined in RFC 7432.

EVPN Building Blocks

There are three fundamental building blocks for EVPN technology, EVPN Instance (EVI), Ethernet Segment (ES), EVPN BGP routes and extended communities:

- EVI is a VPN connection on a PE router. It is the equivalent of IP VPN Routing and Forwarding (VRF) in Layer 3 VPN. It is also known as MAC-VRF.
- ES is a connection with a customer site (device or network) and is associated with access-facing interfaces. Access-facing interfaces are assigned unique IDs that are referred to as Ethernet Segment Identifiers (ESI). A site can be connected to one or more PEs. The ES connection has the same ESI in each PE connected to the site.
- RFC 7432 defines routes and extended communities to enable EVPN support. In Cisco IOS XE Fuji 16.8.x Software Release, Route Type 2 and Route Type 3 are supported.

In BGP MPLS-based EVPN, an EVI is configured for every PE device for each customer associated with the PE device. In this case, a customer is any customer edge device that is attached to the PE device. The CE device can be a host, a switch or a router. Each EVI has a unique Route Distinguisher (RD) and one or more Route Targets (RT).

For EVPN Single-Homing feature, a CE device is attached to a single PE device and has an Ethernet Segment with ESI=0.

Service Interfaces

The following are types of EVPN VLAN service interfaces:

VLAN-based Service Interface

In VLAN-based service interface, each VLAN is associated to one bridge domain and one EVI.

Figure 16: VLAN-Based Service Interface

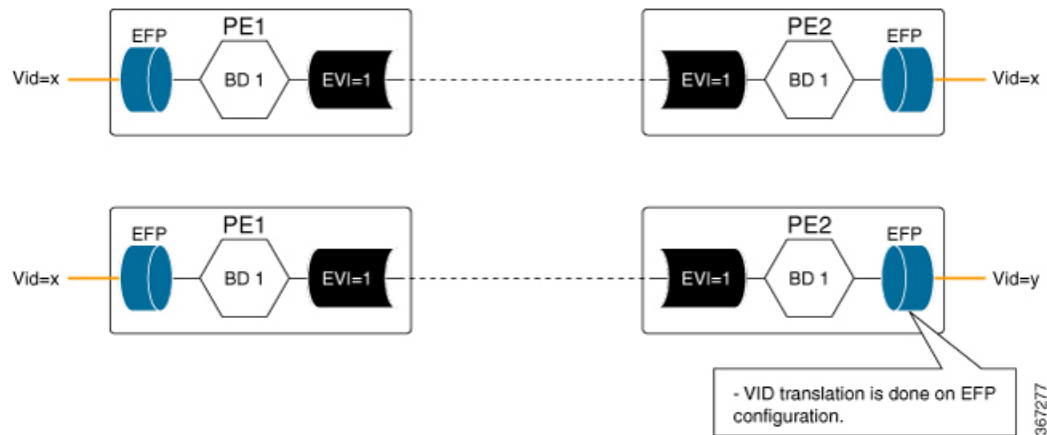

For VLAN-based Service Interface, Type 1 Route Distinguisher, a unique number used to distinguish identical routes in different VRFs, is used for EVIs as recommended by the RFC 7432. The Route Distinguishers and Router Targets, which are used to share routes between different VRFs, are autogenerated to ensure unique Route Distinguisher numbers across EVIs.

VLAN Bundle Service Interface

In VLAN Bundle Service Interface, multiple VLANs share the same bridge table.

Figure 17: VLAN Bundle Service Interface



Each EVPN instance corresponds to multiple broadcast domains maintained in a single bridge table per MAC-VRF. For VLAN Bundle Service Interface service to work, MAC addresses must be unique across all VLANs for an EVI.

VLAN-Aware Bundle Service Interface

For VLAN-aware Bundle Service Interface, each VLAN is associated with one bridge domain, but there can be multiple bridge domains associated with one EVI.

Figure 18: VLAN-Aware Bundle Service Interface

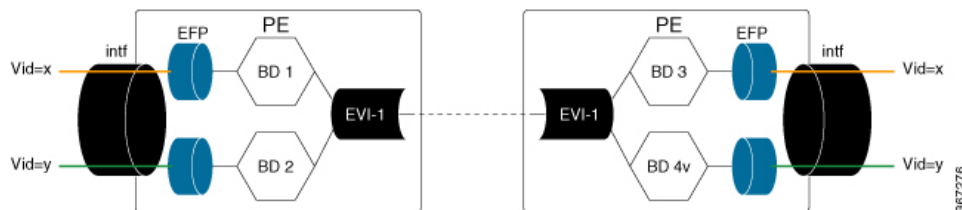

An EVPN instance consists of multiple broadcast domains where each VLAN has one bridge table. Multiple bridge tables (one per VLAN) are maintained by a single MAC-VRF that corresponds to the EVPN instance.

Route Types

For EVPN Single-Homing feature, Route Type 2 and Route Type 3 are supported, as defined by RFC 7432.

Route Type 2 — MAC and IP Advertisement Route

Type 2 Routes are used to advertise MAC addresses and their associated IP addresses. When a PE router learns the MAC address of a CE device that is connected to it locally, or a MAC address of a device behind the CE device, a MAC and an IP advertisement route is created.

The following table describes the header format for the MAC and IP Advertisement Route packet:

Table 19: Header format for the MAC and IP Advertisement Route packet

Field	Value	Length (Octets)
Route Type	0x02	1
Length	Variable	1
EVI RD	Type 1 (IPv4 address) RD unique across all EVIs on the PE	8

Field	Value	Length (Octets)
ESI	Ethernet Segment Identifier	10
Ethernet Tag	0 or valid Ethernet Tag	4
MAC Addr Len	48	1
MAC Address	Valid MAC address	6
IP Addr Length	IP address length in bits: 0, 32 or 128	1
IP Address	Optional IP address	0 or 4 or 16
Label1	Valid downstream assigned label to perform forwarding to a CE device based on the destination MAC address	3
Label2	Specifies a second label	0-3
EVI RT	Type 0 (2byteAS) route target	8

**Note**

- MAC Address field is populated with the CE address.
- IP address field is optional with IP Address length set to 0 bits.
- For EVPN Single-Homing feature, ESI value is always set to 0.
- In the Label field (Label1, Label2), Per-BD or Per-CE labels can be assigned.
 - Per-BD is used when PE advertises a single label for all MAC addresses learned in a given bridge domain.
 - Per-CE label assigns a separate label to each access port in the bridge domain.

Route Type 3 — Inclusive Multicast Ethernet Tag Route

Type 3 routes are used for transporting Broadcast, Unknown Unicast, and Multicast (BUM) traffic to other PE devices across a given EVPN network instance.

The following tables describes the header format for Type 3 routes:

Table 20: Header Format for Type 3 Route Packets

Field	Value	Length (Octets)
Route Type	0x03	1
Length	26 or 38	1

Field	Value	Length (Octets)
EVI RD	Type 1 (IPv4Addr) RD unique across all EVIs on the PE	8
Ethernet Tag	0 or valid Ethernet Tag	4
IP Addr Length	IP Address Length - 32 bits or 128 bits	1
IP Address	IP Address common for all EVIs (for example, loopback address)	4 or 16
PMSI Tunnel Attr	{1 byte flags = 0}; {1 byte Tunnel Type}; {3 byte label}; {variable length Tunnel Identifier}	Variable
EVI RT	Type 0 (2byteAS) route target	8

The PE devices advertise an Inclusive Multicast Ethernet Tag (IMET) Route for every EVI-Ethernet Tag sequence. The Ethernet Tag is set to 0 for VLAN-based and VLAN-bundling service interfaces. The Ethernet Tag is set to a valid VLAN ID for VLAN-aware bundling service interface.

Type 3 route also carries a Provider Multicast Service Interface (PMSI) Tunnel attribute as specified in RFC 6514 (BGP Encodings and Procedures for MVPNs).

For Ingress Replication, the IMET route is used to advertise the label (in the PMSI Tunnel Attribute) that the other PEs can use to send BUM traffic to the originating PE device.

Prerequisites for EVPN Single-Homing

- EVI and Bridge domains must be in established state with associated MPLS labels.

Restrictions for EVPN Single-Homing

- Route Type 1 and Route Type 4 are not supported.
- Per-EVI-based labelling is not supported.
- Maximum number of supported bridge domains is 1600.
- Maximum number of supported EEPs or service instances is 8000.
- Single-Homing feature is not supported with port channel interface between Provider Edge and Customer Edge devices.
- If want to create a VLAN-bundle or VLAN-aware EVI's, they must be configured before adding to a bridge domain (or VLAN).
- ESI must be all 0s.

How to Configure EVPN Single Homing

Configuring EVPN

Figure 19: EVPN Single Homing

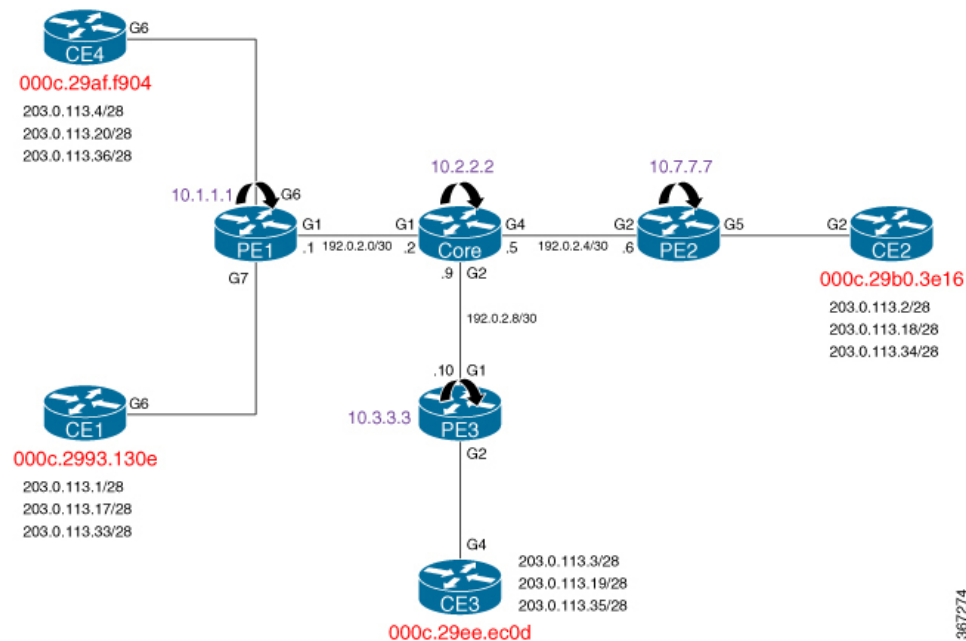

The above figure represents a simple EVPN network. Use the following steps to configure EVPN:

EVPN Configuration

```
enable
  configure terminal
    l2vpn evpn
      replication-type ingress
      router-id Loopback1
      mpls label mode per-ce
    !
    l2vpn evpn instance 10 vlan-based
      route-distinguisher 10.1.1.1:10
      route-target both 10:10
      no auto-route-target
    !
    bridge-domain 10
    member evpn-instance 10
      member GigabitEthernet 0/0/1 service-instance 10
    !
    interface GigabitEthernet 0/0/1
      no ip address
      service instance 10 ethernet
      encapsulation dot1q 200
    !
  !
```



Note In the above example, the **l2vpn evpn instance** command and the associated sub-mode is only required if one or more of the following apply:

- There is per-EVI configuration to be applied (for example, route targets or route distinguished)
- The EVI is VLAN-bundle or VLAN-aware.
- Configure member EVPN instance EVI under the bridge-domain without configuring EVPN instance.

If the EVPN instance is not explicitly configured, it is created automatically as a VLAN-based EVI with autogenerated route targets and route distinguisher.

Configuring L2VPN EVPN Globally and EVI on IOS-XE Router

```
l2vpn evpn
  replication-type ingress ----> Enables ingress replication label
!
l2vpn evpn instance 10 vlan-based ---> Configures Vlan-based EVI 10
!
l2vpn evpn instance 20 vlan-bundle ----> Configures Vlan-bundled EVI 20
!
l2vpn evpn instance 30 vlan-aware ----> Configures Vlan-aware EVI 30
```

Configuring Bridge Domains on IOS-XE Router

```
bridge-domain 10
  mac aging-time 30
  member GigabitEthernet6 service-instance 10 --> Links SI 10 on interface with Bridge-domain
  10
  member evpn-instance 10 --> Links EVI 10 with Bridge-domain 10
!
bridge-domain 20
  mac aging-time 30
  member GigabitEthernet6 service-instance 20 --> Links SI 20 on interface with Bridge-domain
  20
  member evpn-instance 20 --> Links EVI 20 with Bridge-domain 20
!
bridge-domain 30
  mac aging-time 30
  member GigabitEthernet6 service-instance 30 --> Links SI 30 on interface with Bridge-domain
  30
  member evpn-instance 30 ethernet-tag 30 --> Links EVI 30 with Bridge-domain 30
```

Configuring Access Interface on a Provider Edge

```
interface GigabitEthernet6
  no ip address
  negotiation auto
  service instance 10 ethernet ----> Enables service instance 10 under the physical interface

  encapsulation dot1q 10
!
  service instance 20 ethernet ----> Enables service instance 20 under the physical interface

  encapsulation dot1q 20-21
!
  service instance 30 ethernet ----> Enables service instance 30 under the physical interface
```

```
encapsulation dot1q 30
```

Configuring EVPN Single-Homing

Use the following steps to configure EVPN Single-Homing:

Configuring BGP on Provider Edge Device, PE1

```
enable
configure terminal
router bgp 100
  bgp router-id 10.1.1.1
  bgp log-neighbor-changes
  bgp graceful-restart
  neighbor 10.2.2.2 remote-as 100
  neighbor 10.2.2.2 update-source Loopback0
!
address-family ipv4
  neighbor 10.2.2.2 activate
exit-address-family
!
address-family l2vpn evpn      ----> Enables L2VPN EVPN address family
  neighbor 10.2.2.2 activate
  neighbor 10.2.2.2 send-community both
  neighbor 10.2.2.2 soft-reconfiguration inbound
exit-address-family
```

Configuring BGP on Route Reflector

```
router bgp 100
  bgp router-id 10.2.2.2
  bgp log-neighbor-changes
  bgp graceful-restart
  neighbor 10.1.1.1 remote-as 100
  neighbor 10.1.1.1 update-source Loopback0
  neighbor 10.3.3.3 remote-as 100
  neighbor 10.3.3.3 update-source Loopback0
  neighbor 10.7.7.7 remote-as 100
  neighbor 10.7.7.7 update-source Loopback0
!
address-family ipv4
  neighbor 10.1.1.1 activate
  neighbor 10.1.1.1 route-reflector-client
  neighbor 10.3.3.3 activate
  neighbor 10.3.3.3 route-reflector-client
  neighbor 10.7.7.7 activate
  neighbor 10.7.7.7 route-reflector-client
exit-address-family
!
address-family l2vpn evpn      ----> Enables L2vpn evpn address family
  neighbor 10.1.1.1 activate
  neighbor 10.1.1.1 send-community both
  neighbor 10.1.1.1 route-reflector-client
  neighbor 10.1.1.1 soft-reconfiguration inbound
  neighbor 10.3.3.3 activate
  neighbor 10.3.3.3 send-community both
  neighbor 10.3.3.3 route-reflector-client
  neighbor 10.3.3.3 soft-reconfiguration inbound
  neighbor 10.7.7.7 activate
  neighbor 10.7.7.7 send-community both
```

```
neighbor 10.7.7.7 route-reflector-client
neighbor 10.7.7.7 soft-reconfiguration inbound
exit-address-family
```

Configuring Customer Edge and Provider Edge Interfaces

CE1 configuration

```
interface GigabitEthernet6.10
encapsulation dot1Q 10
ip address 203.0.113.1 255.255.255.240
interface GigabitEthernet6.20
encapsulation dot1Q 20
ip address 203.0.113.17 255.255.255.240
interface GigabitEthernet6.30
encapsulation dot1Q 30
ip address 203.0.113.33 255.255.255.240
```

PE1 Configuration

```
interface GigabitEthernet6
no ip address
negotiation auto
service instance 10 ethernet
encapsulation dot1q 10
!
service instance 20 ethernet
encapsulation dot1q 20-21
!
service instance 30 ethernet
encapsulation dot1q 30
```

Verification Examples for EVPN Single-Homing

Use the following command to verify that EVI and Bridge domains are in established state and to display associated MPLS labels:

```
show l2vpn evpn evi detail
EVPN instance: 10 (VLAN Based) ----> VLAN Based EVI
RD: 10.1.1.1:10 (auto) ----> RD derived from Loopback0 of PE1
Import-RTs: 100:10
Export-RTs: 100:10
Per-EVI Label: none
State: Established ----> EVI state
Encapsulation: mpls
Bridge Domain: 10
Ethernet-Tag: 0
BUM Label: 23 ----> Broadcast/Unknown unicast/Multicast traffic label
Per-BD Label: 22
State: Established ----> Bridge-domain state
Pseudoports:
GigabitEthernet6 service instance 10 ----> Local interface part of bridge-domain
GigabitEthernet7 service instance 10 ----> Local interface part of bridge-domain

EVPN instance: 20 (VLAN Bundle) ----> VLAN Bundled EVI
RD: 10.1.1.1:20 (auto)
Import-RTs: 100:20
Export-RTs: 100:20
Per-EVI Label: none
State: Established
```

```

Encapsulation: mpls
Bridge Domain: 20
  Ethernet-Tag: 0
  BUM Label: 20
  Per-BD Label: 21
  State:      Established
Pseudoports:
  GigabitEthernet6 service instance 20
  GigabitEthernet7 service instance 20

EVPN instance: 30 (VLAN Aware) ----> VLAN-Aware EVI
RD:           10.1.1.1:30 (auto)
Import-RTs:   100:30
Export-RTs:   100:30
Per-EVI Label: none
State:        Established
Encapsulation: mpls
Bridge Domain: 30
  Ethernet-Tag: 30
  BUM Label: 18
  Per-BD Label: 19
  State:      Established
Pseudoports:
  GigabitEthernet6 service instance 30
  GigabitEthernet7 service instance 30

```

Use the following command to verify that the bridge domain has learnt the local and remote MAC addresses:

```

PE1#show bridge-domain 10
Bridge-domain 10 (3 ports in all)
State: UP                               Mac learning: Enabled
Aging-Timer: 30 second(s) ----> MAC aging timer for bridge-domain
  GigabitEthernet6 service instance 10
  GigabitEthernet7 service instance 10
  EVPN Instance 10
AED MAC address   Policy Tag      Age  Pseudoport
- 000C.29B0.3E16 forward static_r  0   OCE_PTR:0xe8eb04a0 ----> Remotely learnt MAC
- 000C.29AF.F904 forward dynamic_c 29  GigabitEthernet6.EFP10 --> MAC locally learnt

- 000C.2993.130E forward dynamic_c 26  GigabitEthernet7.EFP10
- 000C.29EE.EC0D forward static_r  0   OCE_PTR:0xe8eb0500

```



Note In the above output, MAC addresses with forward dynamic_c tags are locally learned addresses and MAC addresses with forward static_r tags are remote addresses learned through EVPN.

Use the following command to verify that EVPN manager has received the local MACs learned by the bridge domain:

```

PE1# show l2vpn evpn mac
MAC Address      EVI  BD   ESI                               Ether Tag  Next Hop
-----
000c.2993.130e 10   10   0000.0000.0000.0000.0000         0          Gi7:10
000c.29af.f904 10   10   0000.0000.0000.0000.0000         0          Gi6:10
000c.29b0.3e16 10   10   0000.0000.0000.0000.0000         0          10.7.7.7
000c.29ee.ec0d 10   10   0000.0000.0000.0000.0000         0          10.3.3.3

PE1# show l2vpn evpn mac detail

```

```

MAC Address:          000c.2993.130e
EVPN Instance:       10
Bridge Domain:       10
Ethernet Segment:    0000.0000.0000.0000.0000
Ethernet Tag ID:     0
Next Hop(s):         GigabitEthernet7 service instance 10
Label:               22
Sequence Number:     0
MAC only present:    Yes
MAC Duplication Detection: Timer not running

MAC Address:          000c.29ee.ec0d
EVPN Instance:       10
Bridge Domain:       10
Ethernet Segment:    0000.0000.0000.0000.0000
Ethernet Tag ID:     0
Next Hop(s):         10.3.3.3
Local Address:       10.1.1.1
Label:               19
Sequence Number:     0
MAC only present:    Yes
MAC Duplication Detection: Timer not running

```



Note In the above output, the next hop address of the remote MAC is the address of the provider edge device, if it is learnt remotely or the local interface if MAC address is learnt locally.

Use the following command to verify that Layer 2 Routing Information Base (RIB) has the required the MAC info:

```

PE1# show l2vpn l2route evpn mac
-----
EVI      ETag  Prod  Mac Address                Next Hop(s)  Seq Number
-----
10       0  L2VPN 000C.2993.130E             Gi7:10       0
10       0  L2VPN 000C.29AF.F904             Gi6:10       0
10       0  BGP   000C.29B0.3E16             L:19 IP:10.7.7.7  0
10       0  BGP   000C.29EE.EC0D             L:19 IP:10.3.3.3  0

```



Note Remote MACs are learnt through BGP. In the above command output, the producer is BGP and local MACs are learned through Layer 2 VPN.

Use the following command to verify that Layer 2 FIB has received the MAC information from Layer 2 RIB, and bridge-domain and MFI are configured.

```

PE1# show l2fib bridge-domain 10 detail
Bridge Domain : 10
Reference Count : 18
Replication ports count : 4
Unicast Address table size : 4
IP Multicast Prefix table size : 4

Flood List Information :
  Olist: Id 9225, Port Count 4

Port Information :

```

```

Serv Inst: Gi6:10
Serv Inst: Gi7:10
EVPN MPLS Encap: pathlist 107
EVPN MPLS Encap: pathlist 101

Unicast Address table information :
Mac: 000c.2993.130e, Adjacency: Serv Inst: Gi7:10
Mac: 000c.29af.f904, Adjacency: Serv Inst: Gi6:10
Mac: 000c.29b0.3e16, Adjacency: EVPN MPLS Encap: pathlist 98
Mac: 000c.29ee.ec0d, Adjacency: EVPN MPLS Encap: pathlist 104

IP Multicast Prefix table information :
Source: *, Group: 224.0.0.0/4, IIF: , Adjacency: Olist: 9226, Ports: 0
Source: *, Group: 224.0.0.0/24, IIF: , Adjacency: Olist: 9225, Ports: 4
Source: *, Group: 224.0.1.39, IIF: , Adjacency: Olist: 9225, Ports: 4
Source: *, Group: 224.0.1.40, IIF: , Adjacency: Olist: 9225, Ports:

```

Use the following command to verify that the information on BGP route type 3 is sent to L2RIB:

```

PE1# show l2vpn l2route evpn imet

```

EVI	ETAG	Prod	Router IP	Addr	Type	Label	Tunnel ID
10	0	BGP	10.3.3.3	6	18	10.3.3.3	
10	0	BGP	10.7.7.7	6	18	10.7.7.7	
10	0	L2VPN	10.1.1.1	6	23	10.1.1.1	

Use the following command to verify MPLS forwarding:

```

PE1#show mpls forwarding-table

```

Local Label	Outgoing Label	Prefix or Tunnel Id	Bytes Switched	Label	Outgoing interface	Next Hop
18	No Label	evpn(mc:bd 30)	305042		none	point2point
19	No Label	evpn(uc:bd 30)	7684		none	point2point
20	No Label	evpn(mc:bd 20)	542588		none	point2point
21	No Label	evpn(uc:bd 20)	13786		none	point2point
22	No Label	evpn(uc:bd 10)	6638		none	point2point
23	No Label	evpn(mc:bd 10)	277740		none	point2point
24	Pop Label	192.0.2.2-A	0		Gi1	192.0.2.2
25	Pop Label	192.0.2.2-A	0		Gi1	192.0.2.2
16001	16001	10.3.3.3/32	0		Gi1	192.0.2.2
16002	Pop Label	10.2.2.2/32	0		Gi1	192.0.2.2
16004	16004	10.7.7.7/32	0		Gi1	192.0.2.2

```

PE1# show ip bgp l2vpn evpn route-type 2
BGP routing table entry for [2][10.1.1.1:10][0][48][000C2993130E][0][*]/20, version 43
Paths: (1 available, best #1, table evi_10)
  Advertised to update-groups:
    2
  Refresh Epoch 1
  Local
    :: (via default) from 0.0.0.0 (10.1.1.1)
      Origin incomplete, localpref 100, weight 32768, valid, sourced, local, best
      EVPN ESI: 00000000000000000000, Label1 22
      Extended Community: RT:100:10
      rx pathid: 0, tx pathid: 0x0
BGP routing table entry for [2][10.1.1.1:10][0][48][000C29B03E16][0][*]/20, version 116
Paths: (1 available, best #1, table evi_10)
  Not advertised to any peer
  Refresh Epoch 3
  Local, (received & used), imported path from [2][10.7.7.7:10][0][48][000C29B03E16][0][*]/20

```

```

(global)
  10.7.7.7 (metric 30) (via default) from 10.2.2.2 (10.2.2.2)
    Origin incomplete, metric 0, localpref 100, valid, internal, best
    EVPN ESI: 00000000000000000000, Label1 19
    Extended Community: RT:100:10
    Originator: 10.7.7.7, Cluster list: 10.2.2.2
    rx pathid: 0, tx pathid: 0x0
BGP routing table entry for [2][10.1.1.1:10][0][48][000C29B03E16][0][*]/20, version 116
Paths: (1 available, best #1, table evi_10)
  Not advertised to any peer
  Refresh Epoch 3
  Local, (received & used), imported path from [2][10.7.7.7:10][0][48][000C29B03E16][0][*]/20
(global)
  10.7.7.7 (metric 30) (via default) from 10.2.2.2 (10.2.2.2)
    Origin incomplete, metric 0, localpref 100, valid, internal, best
    EVPN ESI: 00000000000000000000, Label1 19
    Extended Community: RT:100:10
    Originator: 10.7.7.7, Cluster list: 10.2.2.2
    rx pathid: 0, tx pathid: 0x0
BGP routing table entry for [2][10.1.1.1:10][0][48][000C29EEEC0D][0][*]/20, version 134
Paths: (1 available, best #1, table evi_10)
  Not advertised to any peer
  Refresh Epoch 3
  Local, (received & used), imported path from [2][10.3.3.3:10][0][48][000C29EEEC0D][0][*]/20
(global)
  10.3.3.3 (metric 30) (via default) from 10.2.2.2 (10.2.2.2)
    Origin incomplete, metric 0, localpref 100, valid, internal, best
    EVPN ESI: 00000000000000000000, Label1 19
    Extended Community: RT:100:10
    Originator: 10.3.3.3, Cluster list: 10.2.2.2
    rx pathid: 0, tx pathid: 0x0

PE1# show ip bgp l2vpn evpn route-type 3
BGP routing table entry for [3][10.1.1.1:10][0][32][10.1.1.1]/17, version 41
Paths: (1 available, best #1, table evi_10)
  Advertised to update-groups:
    2
  Refresh Epoch 1
  Local
    :: (via default) from 0.0.0.0 (10.1.1.1)
      Origin incomplete, localpref 100, weight 32768, valid, sourced, local, best
      Extended Community: RT:100:10
      PMSI Attribute: for EVPN, Flags: 0x0, Tunnel type: 6, length 4, label: 23 (vni 368)
  tunnel parameters: 0101 0101
    rx pathid: 0, tx pathid: 0x0
BGP routing table entry for [3][10.1.1.1:10][0][32][10.3.3.3]/17, version 137
Paths: (1 available, best #1, table evi_10)
  Not advertised to any peer
  Refresh Epoch 3
  Local, (received & used), imported path from [3][10.3.3.3:10][0][32][10.3.3.3]/17 (global)

    10.3.3.3 (metric 30) (via default) from 10.2.2.2 (10.2.2.2)
      Origin incomplete, metric 0, localpref 100, valid, internal, best
      Extended Community: RT:100:10
      Originator: 10.3.3.3, Cluster list: 10.2.2.2
      PMSI Attribute: for EVPN, Flags: 0x0, Tunnel type: 6, length 4, label: 18 (vni 288)
  tunnel parameters: 0303 0303
    rx pathid: 0, tx pathid: 0x0
BGP routing table entry for [3][10.1.1.1:10][0][32][10.7.7.7]/17, version 122
Paths: (1 available, best #1, table evi_10)
  Not advertised to any peer
  Refresh Epoch 3
  Local, (received & used), imported path from [3][10.7.7.7:10][0][32][10.7.7.7]/17 (global)

```



```
10.7.7.7 (metric 30) (via default) from 10.2.2.2 (10.2.2.2)
  Origin incomplete, metric 0, localpref 100, valid, internal, best
  Extended Community: RT:100:10
  Originator: 10.7.7.7, Cluster list: 10.2.2.2
  PMSI Attribute: for EVPN, Flags: 0x0, Tunnel type: 6, length 4, label: 18 (vni 288)
tunnel parameters: 0707 0707
  rx pathid: 0, tx pathid: 0x0
```

Additional References for EVPN Single-Homing

Standards and RFCs

Standard	Title
RFC 7432	BGP MPLS-Based Ethernet VPN



CHAPTER 15

Pseudowire Stitching

Pseudowire stitching is a technique where a pair of independent pseudowires are configured in such a way that they behave like a single point to point pseudowire. It is also called as multi-segment pseudowire (MS-PW).

Pseudowire stitching can be achieved using cross-connect.

- [Benefits of Pseudowire Stitching](#) , on page 239
- [Configuring Pseudowire Stitching](#) , on page 239
- [Verifying Pseudowire Stitching](#) , on page 240

Benefits of Pseudowire Stitching

Pseudowire stitching is useful in scenarios where a large network needs to be divided into small pieces, for example, core and metro side, each part of the network will be stitched to achieve end-to-end seamless connectivity.

Configuring Pseudowire Stitching

Below is an example with three nodes connected:

Router IDs are:

- R1 - 10.1.1.1
- R2 - 2.2.2.2
- R3 - 3.3.3.3

Configuration on R1 node:

```
interface GigabitEthernet0/1/0
no ip address
negotiation auto
service instance 1 ethernet
encapsulation dot1q 1
xconnect 2.2.2.2 100 encapsulation mpls
!
```

Configuration on R2 node: (Stitching point)

```
l2vpn xconnect context PW
member 10.1.1.1 100 encapsulation mpls
member 3.3.3.3 100 encapsulation mpls
```

Configuration on R3 node:

```
interface GigabitEthernet0/1/0
no ip address
negotiation auto
service instance 1 ethernet
encapsulation dot1q 1
xconnect 2.2.2.2 100 encapsulation mpls
!
```

Verifying Pseudowire Stitching

```
R2#show mpls l2transport vc
```

Local intf	Local circuit	Dest address	VC ID	Status
pw100010	3.3.3.3 100	10.1.1.1	100	UP
pw100009	10.1.1.1 100	3.3.3.3	100	UP



CHAPTER 16

On-Change Notifications for L2VPN Pseudowire

Table 21: Feature History

Feature Name	Release Information	Description
On-Change Notifications for L2VPN Pseudowire	Cisco IOS XE Bengaluru 17.5.1	This feature allows you to subscribe on-change Network Configuration Protocol (NETCONF) notifications for L2VPN pseudowire. You can generate an alert from a device when the pseudowire status changes.

Prior to Cisco IOS XE Bengaluru Release 17.5.1, it was not possible to externalize the internal IOS state for operational data. Thus, the on-change notifications were not generated for any change of state.

Starting with Cisco IOS XE Bengaluru Release 17.5.1, you can access the internal IOS state of the router to configure or view the running state of the router. The feature allows the externalization of the internal state of the router for the operational data. It helps in sending on-change notifications to the receiver for any change of state, for example, when the pseudowire goes up or down. Thus, you can generate on-change NETCONF notifications for L2VPN pseudowire.

Use the Cisco-IOS-XE-l2vpn-pw-events operational module to configure the feature. The notification event and event data are included in the operational module.

- [IOS State, on page 241](#)
- [Telemetry and L2VPN Pseudowire, on page 242](#)
- [Configuration Examples: On-Change Notifications for L2VPN Pseudowire, on page 242](#)
- [Verification of On-Change Notifications for L2VPN Pseudowire Configuration, on page 243](#)

IOS State

The IOS state can be divided into the following conceptual groups:

- Configuration or configuration state includes:
 - Feature default configuration state (use **show running-config all** command with no user configuration)
 - Non-default configuration state (use **show running-config** command)

- Nonvisible non-persistent feature configuration state (subscriber profiles)
- Operational state includes:
 - Feature state that is not configuration state (pseudowire status)

Telemetry and L2VPN Pseudowire

Telemetry is the process of measuring the state of the components in a system and transmitting it to a remote location for further processing and analysis. Event-driven Telemetry (EDT) optimizes data collected at the receiver by streaming data only when a state transition occurs (for example, stream data only when an interface state transitions, IP route updates, and so on).

For L2VPN pseudowire, the on-change notifications are sent when the pseudowire state changes with link flaps, configuration delete or add, and so on. For more information on the Telemetry feature, see the [Programmability Configuration Guide, Cisco IOS XE Bengaluru 17.4.x](#).

The following events are supported:

- L2VPN Pseudowire status is up
- L2VPN Pseudowire status is down
- VPLS status is up
- VPLS status is down

Configuration Examples: On-Change Notifications for L2VPN Pseudowire

The following examples show the configurations for on-change notifications for L2VPN



521527

On Router PE1:

Configuration for L2VPN Xconnect:

```
interface pseudowire1
encapsulation mpls
neighbor 2.2.2.2 1
!
interface pseudowire2
encapsulation mpls
neighbor 3.3.3.3 2
!
interface gi0/2/0
service instance 10 ethernet
encapsulation dot1q 10
rewrite ingress tag pop 1 symmetric
!
```

```
l2vpn xconnect context test
member pseudowire1 group 1 priority 1
member pseudowire2 group 2 priority 2
member gi0/2/0 service-instance 10
```

Sample Telemetry Configuration for Notification:

```
telemetry ietf subscription 1
encoding encode-tdl
filter tdl-uri /services;serviceName=iosevent/q_pw_session_state
stream native
update-policy on-change
receiver ip address x.x.x.x 45000 protocol native
```

Verification of On-Change Notifications for L2VPN Pseudowire Configuration

Establish Subscription via NETCONF for On-Change Notifications:

The following output displays the subscription creation and establishment that captures pseudowire events via NETCONF:

```
<establish-subscription
xmlns="urn:ietf:params:xml:ns:yang:ietf-event-notifications"
xmlns:yp="urn:ietf:params:xml:ns:yang:ietf-yang-push"
xmlns:cyp="urn:cisco:params:xml:ns:yang:cisco-xe-ietf-yang-push-ext">
<stream>cyp:yang-notif-native</stream>
<yp:xpath-filter>/l2vpn-pw-ios-xe-events:l2vpn-pw-vc-status</yp:xpath-filter>
<yp:dampening-period>0</yp:dampening-period>
</establish-subscription>
```

Confirm Subscription Establishment:

This following output confirms subscription requested for events via NETCONF. This captures the pseudowire events when there is any change in the pseudowire state.

```
<?xml version="1.0" encoding="UTF-8"?>
<rpc-reply xmlns="urn:ietf:params:xml:ns:netconf:base:1.0" message-id="2">
<subscription-result xmlns="urn:ietf:params:xml:ns:yang:ietf-event-notifications"
xmlns:notif-bis="urn:ietf:params:xml:ns:yang:ietf-event-notifications">notif-bis:ok</subscription-result>
<subscription-id
xmlns="urn:ietf:params:xml:ns:yang:ietf-event-notifications">2147483670</subscription-id>
</rpc-reply>
```

The output below shows the verification of on-change notifications for L2VPN pseudowire state configuration.

The following output shows when pseudowire goes Down:

```
<?xml version="1.0" encoding="UTF-8"?>
<notification xmlns="urn:ietf:params:xml:ns:netconf:notification:1.0">
<eventTime>2020-08-25T07:32:35.52Z</eventTime>
<l2vpn-pw-vc-status xmlns="http://cisco.com/ns/yang/Cisco-IOS-XE-l2vpn-pw-events">
<vc-status>pw-vc-down</vc-status>
<vc-id>1022</vc-id>
<peer-ip>1.1.1.2</peer-ip>
</l2vpn-pw-vc-status>
</notification>
```

The following output shows when pseudowire comes Up:

```
<?xml version="1.0" encoding="UTF-8"?>
<notification xmlns="urn:ietf:params:xml:ns:netconf:notification:1.0">
```

```
<eventTime>2020-08-25T07:55:35.52Z</eventTime>  
<l2vpn-pw-vc-status xmlns="http://cisco.com/ns/yang/Cisco-IOS-XE-l2vpn-pw-events">  
<vc-status>pw-vc-up</vc-status>  
<vc-id>1022</vc-id>  
<peer-ip>1.1.1.2</peer-ip>  
</l2vpn-pw-vc-status>  
</notification>
```