



Route Processor

This chapter describes the Cisco CRS Series Enhanced 16-Slot Line Card Chassis (LCC) route processor (RP) card or the performance route processor card (PRP) which are installed in the line card chassis. This chapter also describes the distributed route processor (DRP) card and its associated physical layer interface module (DRP PLIM), which functions as an additional route processor in the Cisco CRS routing system.

This chapter contains the following sections:

- [Route Processor Overview, page 6-1](#)
- [Route Processor Active and Standby Arbitration, page 6-4](#)
- [Route Processor Memory Options, page 6-4](#)
- [Route Processor Card, page 6-4](#)
- [Distributed Route Processor, page 6-6](#)
- [Performance Route Processor, page 6-9](#)

Route Processor Overview

The route processor (RP) card performs the route processing in the Cisco CRS-1 and CRS-3 routing systems and distributes forwarding tables to the MSCs. The RP provides a control path to each MSC, performs system-monitoring functions and contains hard disks for system and error logging.

Although each line card chassis contains two RP cards, only one RP is active at a time. The other RP operates in standby mode, ready to assume control if the active RP fails. See the [“Route Processor Active and Standby Arbitration” section on page 6-4](#) for information on how the system determines which RP is active and which is standby. As of Cisco IOS XR release 3.3.0, the RP and RP-B in tandem for active and standby modes (or vice versa) are supported on the one routing system chassis.

The RP card is also the system controller for the Cisco CRS-1 and CRS-3 routing systems. (See [Chapter 8, “Control Plane,”](#) for more information about system controller functions.) System controller functionality varies between single-shelf and multishelf systems:

- In a single-shelf (standalone) system, the active RP is the system controller for the routing system.
- In a multishelf system, one of the RPs from among all of the line card chassis is selected to be the designated system controller (DSC) for the routing system. (See *Cisco CRS Carrier Routing System Multishelf System Description* for more information about the selection process.)

[Figure 6-1](#) is a simple block diagram of an RP card. The dotted lines indicate distinct RP modules, such as the CPU and memory controller (MEM CTL), and the “to fabric” and “from fabric” sections.

Figure 6-1 Route Processor Simple Block Diagram

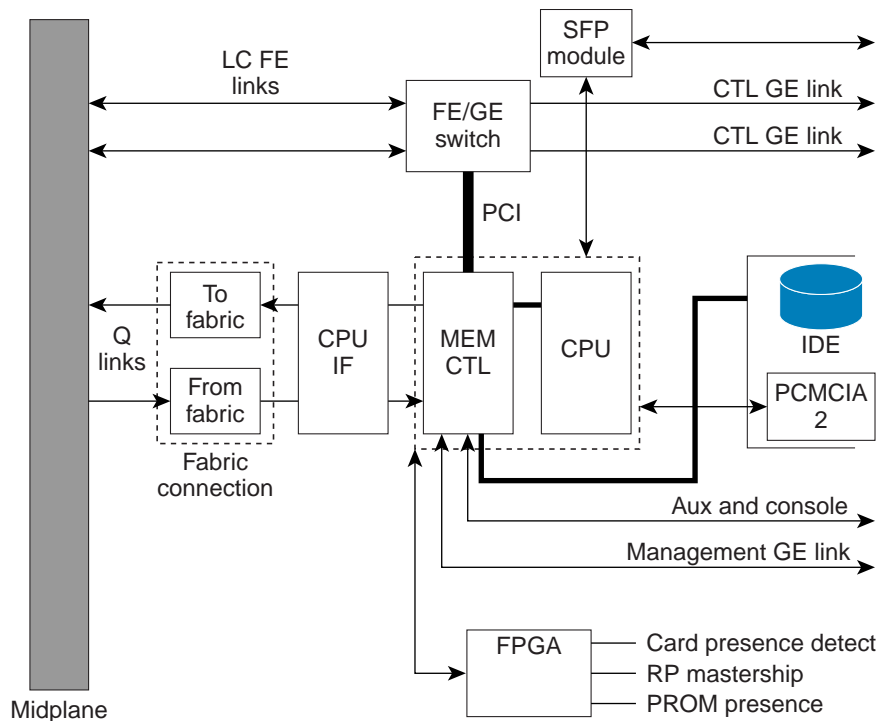

101936

The main components of the RP card are listed here and described in the following sections:

- A dual-CPU symmetric multiprocessor (SMP) performs route processing. The CPU also serves as the MSC service processor (SP), and monitors the RP temperature, voltages, power supply margining (during factory test), and ID EEPROM.
- Two small form-factor pluggable (SFP) modules provide external Gigabit Ethernet (GE) connections. In a multishelf system, these modules connect to two external Cisco Catalyst 6509 Switches that interconnect all line card and fabric chassis together to form a control network. The Cat6509 systems are not used in the single-shelf system.
- A third Ethernet port for 10/100/1000 Ethernet copper provides connectivity to network management systems.
- Internal 100 Mbps Fast Ethernet (FE) midplane connections connect each MSC in the chassis to both RPs. These FE connections are traces in the midplane. There are also FE connections to the fans, blowers and power supplies. These connections all form part of the control plane.
- An IDE hard disk is used to gather debugging information, such as core dumps from the RP or MSCs. See the following section ([“IDE Hard Drive”](#)) for more information.
- PCMCIA flash slots provide support for two PCMCIA flash subsystems that each provide 2GB or 4GB of flash storage. One of the PCMCIA flash subsystems is accessible externally and removable; the other subsystem is fixed to the RP and is not removable. (See the [“PCMCIA Flash Slots”](#) section on page 6-3.)

As shown in [Figure 6-1](#), the RP mates with the LCC midplane. The RP connects to the switch fabric through two fabric interface modules (from fabric and to fabric) that are similar to the fabric interface of the MSC (see the [“MSC To Fabric Section and Queuing”](#) section on page 5-5).

- The from fabric section (which is part of the RP receive path) queues the data from the switch fabric and reorders and reassembles the cells into packets before queuing them for slow-path processing.

- The to fabric module (which is part of the RP transmit path) queues the packets and segments them into cells before transmitting them to the switch fabric.

IDE Hard Drive

The RP hard drive (Figure 6-2) is an IDE hard disk used to gather debugging information, such as core dumps from the RP or MSCs. The hard drive is typically powered down and activated only when there is a need to store data. A hard disk is always provided as part of the RP, but may be removed from the board if necessary (under the direction of Cisco technical support).

Figure 6-2 RP Hard Drive

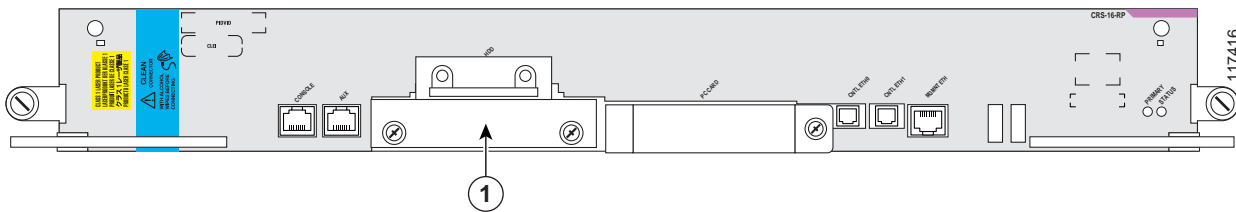

1	Hard drive door
---	-----------------



Note

Physically, the hard drive is a hot-pluggable PC board and sled-mounted drive with a connector interface that seats into an RP card. In general, removal and replacement of this drive is not required.

PCMCIA Flash Slots

The RP card supports two PCMCIA flash cards that each provide up to 2GB or 4GB of flash storage. One of the PCMCIA flash subsystems is accessible externally and removable, and allows you to transfer images and configurations by plugging in a PCMCIA flash card. The other flash subsystem is fixed to the RP and is not removable, and is for permanent storage of configurations and images. Figure 6-3 shows the location of the externally accessible PCMCIA slot on the RP card front panel.



Note

Only the original route processor (RP) card uses a PCMCIA card. The performance route processor (PRP) card has a USB connector for using a flash drive.

Figure 6-3 RP PCMCIA Slots

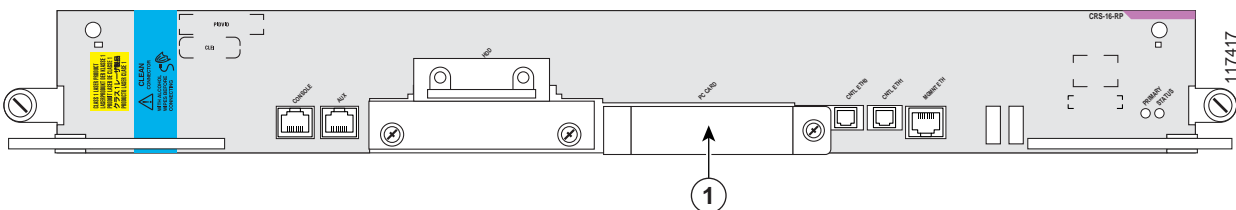

1	PCMCIA flip-up door
---	---------------------

CONSOLE and AUX Ports

The CONSOLE and AUX ports are RJ-45 serial connectors that have the following pinouts:

- Pin 1—Request to send (RTS)
- Pin 2—Data terminal ready (DTR)
- Pin 3—Transmit data (TxD)
- Pin 4—Ground (Gnd)
- Pin 5—Ground (Gnd)
- Pin 6—Receive data (RxD)
- Pin 7—Carrier detect (CD)
- Pin 8—Clear to send (CTS)

Route Processor Active and Standby Arbitration

The two RPs in an LCC operate in an active-standby relationship. Only one RP is active at a time. The other RP operates in standby mode, ready to assume control if the active RP fails.

The routing system performs the following steps to determine which RP is active and which is standby:

1. At chassis power up, each RP boots its board components and runs self-tests.
2. The RPs exchange messages with each other and with the service processors (SPs) on all other boards. Each RP examines its outgoing “Reset” lines to verify that they are inactive.
3. Based on the results of these tests, each RP decides whether it is ready to become shelf (that is, chassis) master, that is the active RP. If it is, it asserts the Ready signal to its on-board arbitration unit. The arbitration unit propagates the Ready signal to the other RP.
4. The arbitration hardware chooses the active RP from the RPs that have asserted Ready. The hardware asserts an Active signal to the chosen RP, along with an interrupt and propagates the Active signal to the other RP, which also receives an interrupt.
5. Software on each RP reads its Active signal, and branches accordingly to Primary or Standby code.
6. If the active RP is removed, powered down, or voluntarily disables its Ready signal, the standby RP becomes active after receiving an asserted Active signal, along with an interrupt.

Route Processor Memory Options

The route processor card can be configured with 2GB or 4GB of memory.

Route Processor Card

[Figure 6-4](#) shows the Cisco CRS routing system RP card. The RP card plugs into the chassis in the center of the lower PLIM card cage, on the front side of the midplane (see [Figure 1-5](#)).

Figure 6-4 Route Processor (RP) Card

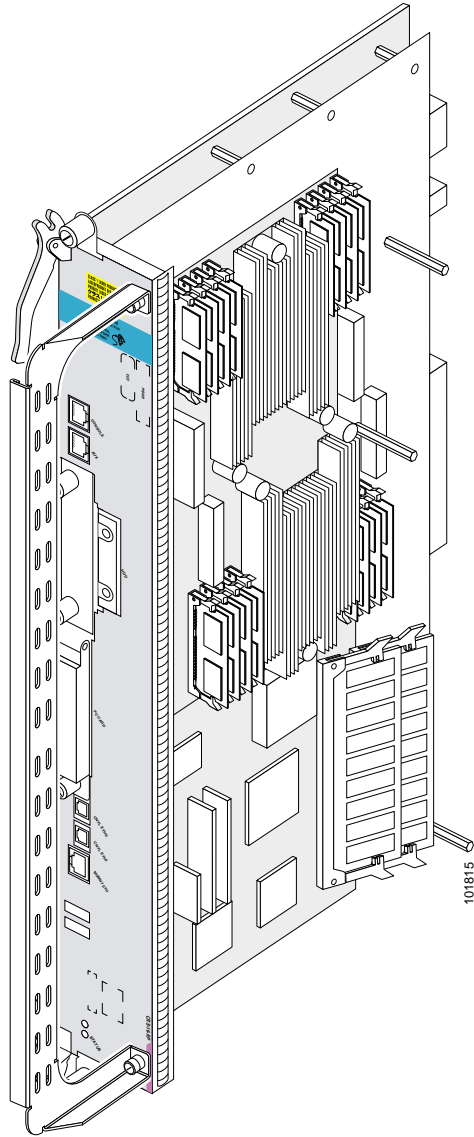
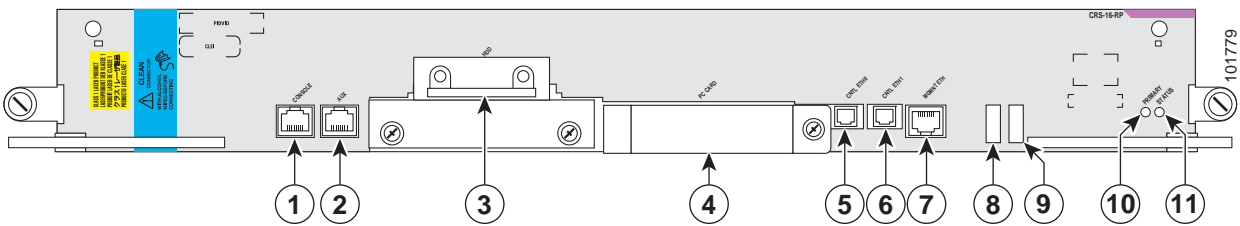

Figure 6-5 shows the RP card front panel.

Figure 6-5 RP Card Front Panel



1	CONSOLE connector	7	Management Ethernet port
2	AUX connector	8	Alphanumeric LED
3	HDD door	9	Alphanumeric LED
4	PC CARD	10	PRIMARY LED
5	Control Ethernet port 0	11	STATUS LED
6	Control Ethernet port 1		

The RP front panel includes:

- IDE hard disk
- PCMCIA flash disk slot
- Two Gigabit Ethernet connections
- GE copper port
- CONSOLE and AUX (RJ-45 serial ports)
- Alphanumeric LED
- Primary LED—Turns on to indicate that the RP is operating in primary mode. When the LED is off, the RP is operating in standby mode.
- Status LED—Green indicates that the RP is properly installed and operating correctly. Yellow indicates there is a problem with the card. If the LED is off, check to make sure that system power is on.

Distributed Route Processor

The distributed route processor (DRP) card and its associated physical layer interface module (PLIM) provide additional routing capabilities for the Cisco CRS routing system. The DRP and DRP PLIM function as an additional route processor (RP) in the system.

A DRP runs any of the routing processes that run on the RP (for example, BGP, OSPF, IS-IS, MPLS, LDP, IP multicast, and so on). You issue software commands to specify which processes are to run on the DRP instead of the RP. This action of assigning processes to a DRP is called *process placement*. By offloading processor-intensive routing tasks (such as BGP speakers and IS-IS) from the RP to the DRP, you can improve system performance.



Note

The distributed route processor (DRP) card and DRP PLIM have no dedicated slots. The DRP card is installed in an open MSC slot and the DRP PLIM is installed in a corresponding PLIM slot.

The DRP does not perform any of the control and management functions performed by the RP; therefore, it can never be the designated shelf controller (DSC) in a multishelf system. However, the DRP can be configured as the designated logical router shelf controller (dLRSC) in a logical router. A *logical router* is a part of the Cisco CRS Series routing system that functions as a complete router, running its own routing protocols and forwarding IP packets between its interfaces.



Note

Currently, the Cisco CRS routing system can function as a single logical router only.

See the “[Limitations and Restrictions](#)” section on page 6-9 for information about the limitations of the DRP that apply to this release.

The following sections describe the DRP card and the DRP PLIM. Throughout these sections, unless otherwise noted, DRP refers to both the DRP and its associated PLIM.

DRP Card

The DRP card (CRS-DRP) is an optional component that enhances Cisco CRS Series routing capabilities by serving as an additional route processor in the system. The DRP can be installed in any MSC (line card) slot in the line card chassis. The corresponding DRP PLIM is installed in the corresponding PLIM slot. The cards are connected to each other through the chassis midplane.

The main components of the DRP are:

- Two symmetric processors (SMP0 and SMP1)—Perform route processing tasks. The SMPs are independent of each other and operate simultaneously. You can assign routing processes, which normally run on the RP, to run on the DRP instead.
- Service processor module—Communicates with the RP (which is the system controller), controls DRP processes, and monitors voltages and temperatures on the DRP and DRP PLIM.
- Two CPUCTRL ASICs—Provide an interface between the SMPs and the switch fabric ASICs. Each ASIC has a set of eight ingress and egress queues for buffering data.
- Several switch fabric ASICs—Provide the interface to and from the switch fabric:
 - Two FabricQ ASICs—Receive cells from the switch fabric, reorder the cells and reassemble them into packets, and queue the packets for transmission to the CPUCTRL ASICs. The FabricQ ASICs are part of the Rx path on the DRP. Each FabricQ ASIC is connected to a different CPUCTRL ASIC.
 - IngressQ ASIC—Receives data packets from the SMP, segments the packets into cells, and distributes the cells to the switch fabric. The ASIC is part of the Tx path on the DRP. The module has connections to both SMPs, but only one SMP controls the IngressQ ASIC at any time. By default, SMP0 controls the ASIC at startup.

The IngressQ ASIC has a memory buffer for storing packets. This buffer storage provides input rate-shaping queues for shaping switch-bound traffic. Input rate shaping is used to provide bandwidth and QoS guarantees for physical and logical port traffic and to smooth traffic bursts into the switch fabric.
 - Two Qlink modules—Provide the interface to the switch fabric. The modules convert data between the format used by the FabricQ and IngressQ ASICs and the format used by the switch fabric. Each Qlink module provides an interface to four planes of the switch fabric.
- Several interfaces—Provide communications paths among the components on the DRP.
- Additional components—Include power and clocking components, voltage and temperature sensors, and an identification EEPROM that stores initial configuration and hardware information.

[Figure 6-6](#) shows the DRP card front panel.

Figure 6-6 DRP Card Front Panel

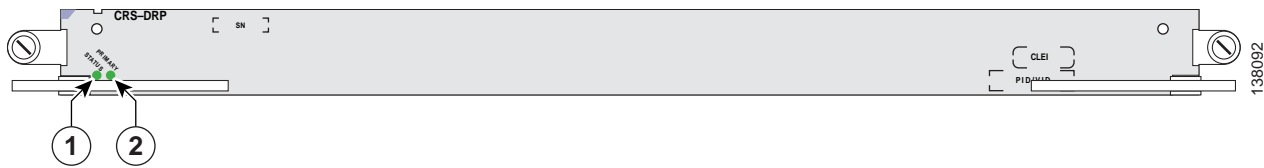

1	STATUS LED	2	PRIMARY LED
---	------------	---	-------------

The DRP front panel contains:

- Primary LED—When two DRP cards are configured as a redundant pair, the LED turns green to indicate that this DRP is currently active. The other DRP is in standby mode; it takes over DRP processing if the active DRP card fails.
- Status LED—Green indicates that the card is operating correctly. Yellow indicates that there is a problem with the card.

The Console, Aux, and Ethernet management ports for the DRP card are located on the DRP PLIM. (See [Figure 6-7](#).)

DRP PLIM

The DRP PLIM, or DRP front-access panel (CRS-DRP-ACC), provides access to the DRP card for configuration and system management. The DRP PLIM contains the CONSOLE, AUX, and Ethernet management ports (MGMT ETH) for the DRP and an alphanumeric LED that shows operational status.

The DRP PLIM is installed in the PLIM slot that corresponds to the MSC slot in which the associated DRP card is installed.

[Figure 6-7](#) shows the front panel of the DRP PLIM.

Figure 6-7 DRP PLIM Front Panel

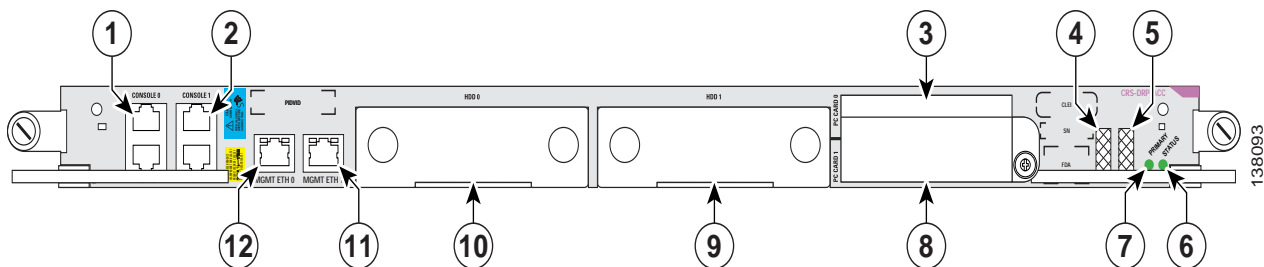

1	CONSOLE port 0	7	PRIMARY LED
2	CONSOLE port 1	8	PC card 1
3	PC Card 0	9	Hard drive 1
4	Alphanumeric LED	10	Hard drive 0

5	Alphanumeric LED	11	MGMT ETH port 1
6	STATUS LED	12	MGMT ETH port 0

The DRP PLIM front panel contains the following components:

- Two CONSOLE ports (one set of ports for each SMP)—Provide RJ-45 serial interfaces for local and remote (modem) console terminal connections.
- Management Ethernet ports (one port for each SMP)—Provide a 10/100/1000 Ethernet interface for configuration and management (RJ-45 connector).
- Two 40-gigabyte removable hard disk drives (one for each SMP)—Store troubleshooting and debugging information.
- Two PCMCIA flash disk slots (one for each SMP)—Accept a 1-gigabyte PCMCIA flash card for storing software images.
- Alphanumeric LED (eight-digit display)—Indicates the status of the DRP and DRP PLIM cards.

Limitations and Restrictions

The current Cisco CRS Series multishelf system supports DRP functionality, with the following limitations:

- Each line card chassis supports multiple DRPs and multiple DRP PLIMs.
- Redundant DRP operation (or *DRP pairing*) is currently not supported. In the future, you will be able to install a pair of DRPs in the chassis and configure them for high availability. When paired, the DRPs operate in active and standby mode. Only one DRP is active at a time, while the other DRP functions in standby mode, ready to take over processing if the active DRP fails.
- For processes to run on the DRP, you must override the default process placement policy and configure the processes to run on a single (unpaired) DRP. This reconfiguration is necessary because the default placement policy assigns processes to paired DRPs only.

Performance Route Processor



Note

For the Cisco CRS-X, the PRP is required instead of the RP.

The Performance Route Processor (PRP) is also available for the LCC. The PRP provides enhanced performance for both route processing and system controller functionality.

Two PRP cards are required per chassis for a redundant system. The PRP can be inserted in either of the two dedicated RP slots in the LCC. When two PRPs are installed, one PRP is the “Active” RP and the other is the “Standby” RP.

Figure [Figure 6-8](#) shows the PRP card.

Figure 6-8 Performance Route Processor

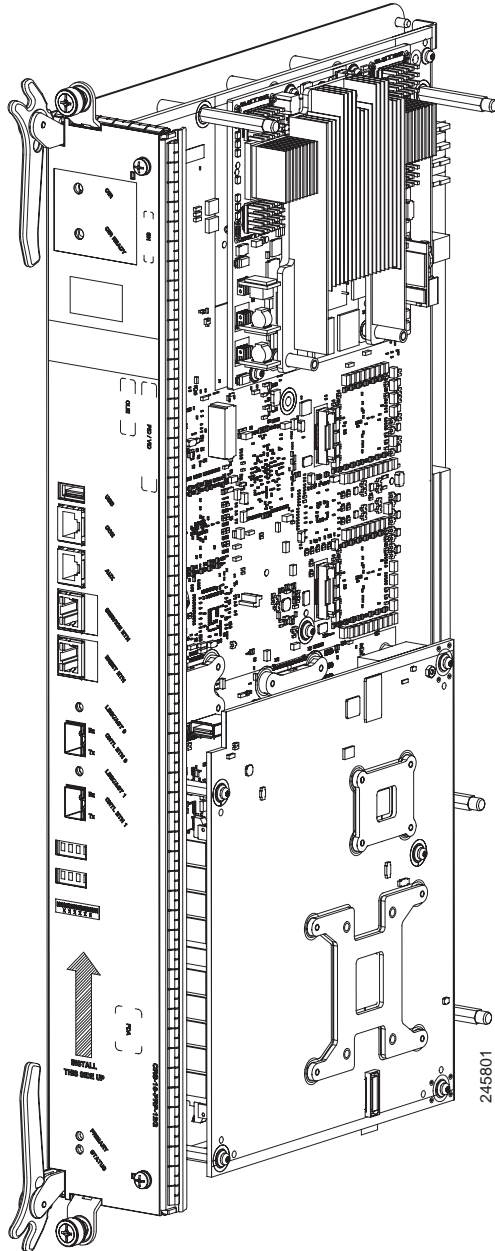

The PRP has the following physical characteristics:

- Height—20.6 in. (52.3 cm)
- Depth—11.2 in. (28.5 cm)
- Width—2.8 in. (7.1 cm)
- Weight—12.9 lb (5.85 kg)
- Power consumption—275 W (with two SFP or SFP+ optics modules)

Performance Route Processor Front Panel

The PRP front panel includes:

- Two 1GE (SFP) or 10G (SFP+) ports for 1-GE or 10-GE uplinks
- Service Ethernet RJ45 port
- Console port
- Auxiliary port
- Push button switch to Initiate OIR process
- LED to indicate OIR status and readiness for extraction
- Alphanumeric Display
- LEDs for card status and RP Active or Standby status
- USB socket

Figure 6-9 shows the front panel of the PRP card.

Figure 6-9 Performance Route Processor Front Panel

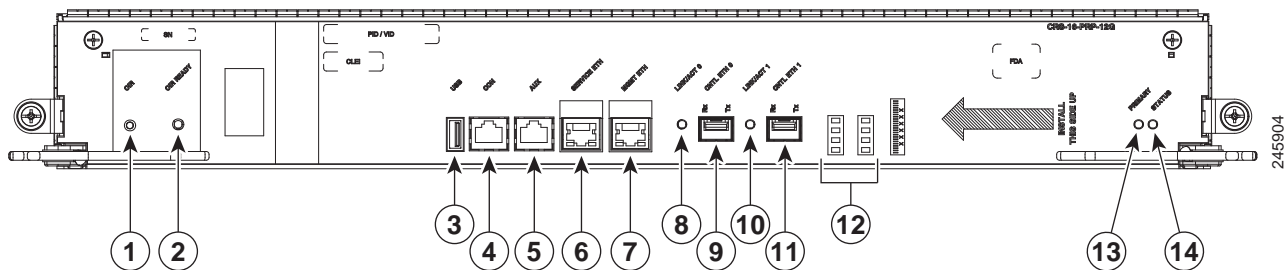

1	OIR push button—initiates OIR process	8	Link/Active 0 LED
2	OIR Ready LED	9	Control Ethernet 0 port (SFP or SFP+)
3	USB socket	10	Link/Active 1 LED
4	Console port	11	Control Ethernet 1 port (SFP or SFP+)
5	Auxiliary port	12	Alphanumeric LED Display
6	Service Ethernet RJ45 port	13	PRP Active or Standby status LED
7	Management Ethernet RJ45 port	14	Card Status LED

Performance Route Processor Overview

The CRS PRP for the LCC is a next generation Intel-based RP that increases the CPU compute power, memory and storage capacity. The PRP provides both route processing and system controller functionality for enhanced performance.

A CPU interface and system control ASIC provides resources and communication paths between the CPU and the rest of the system to provide line card management, configuration, monitoring, protocol control, and exception packet handling. The fabric queuing portion of this ASIC acts as the fabric interface to handle the traffic to the fabric. Traffic from the fabric is handled by the ingress queuing portion of an interface bridging FPGA.

**Note**

A chassis may not be populated with a mix of RP and PRP cards. Both route processor cards should be of the same type (RP or PRP).

Figure 6-10 shows a block diagram of the PRP card.

Figure 6-10 Performance Route Processor Block Diagram

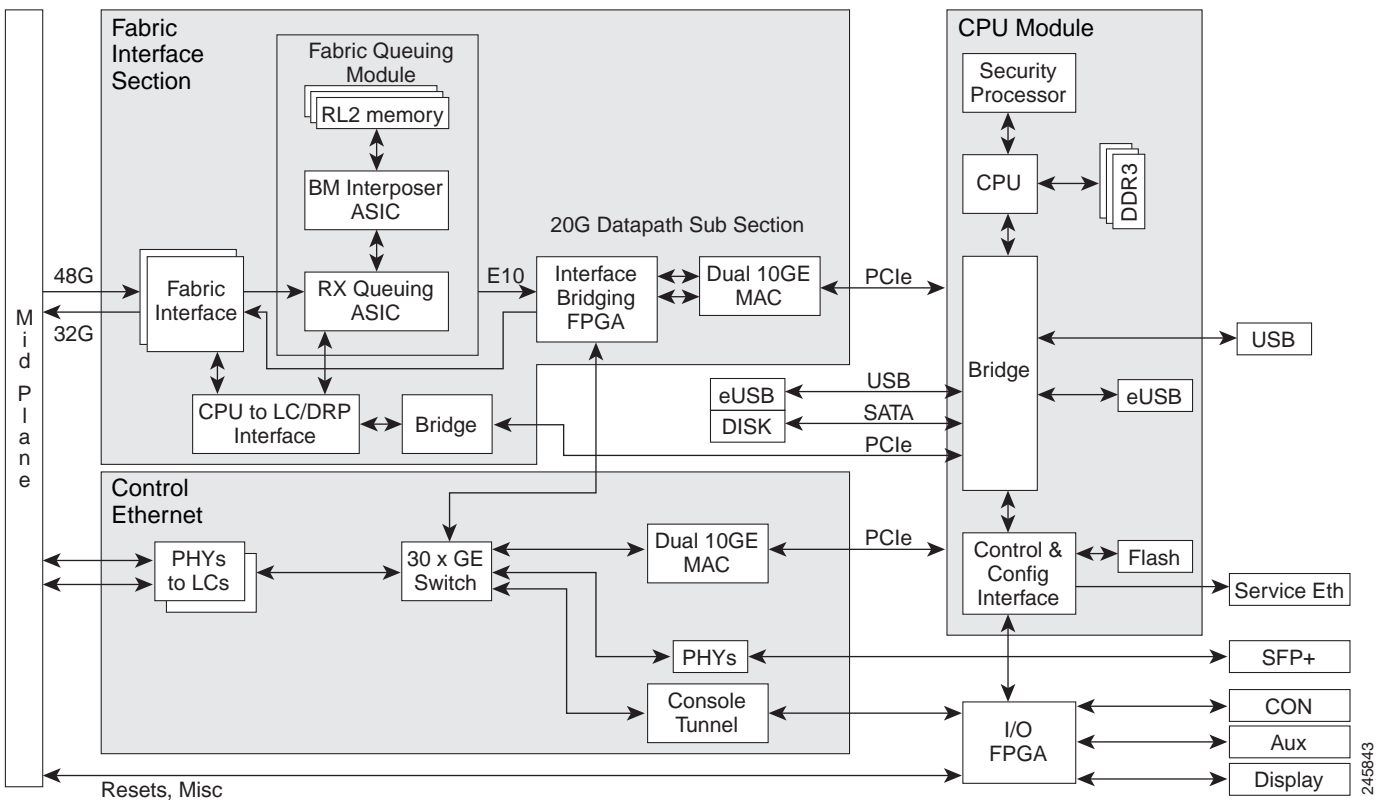

Performance Route Processor Memory Options

The following memory configurations are supported by the CPU memory controller:

- Three 2GB DDR3 DIMMs, for a total of 6GB
- Three 4GB DDR3 DIMMs, for a total of 12GB

**Note**

The memory on the 6GB PRP is not upgradable to 12GB.

Initiate OIR Pushbutton

The PRP front panel includes an OIR pushbutton (see item 1 in [Figure 6-9](#)). Pressing the OIR button initiates the OIR process and avoids the loss of card information caused by a surprise extraction.

If a card is extracted without initiating the OIR process (surprise extraction), the saving of logs or other important information is not possible. Although surprise extraction is supported, using the OIR process allows you to save important card information and logs.

After pressing the button, the OIR Ready LED (item 2 in [Figure 6-9](#)) blinks during the OIR process. When the OIR process is complete, the OIR Ready LED glows solidly to indicate that the board is ready for extraction.

If for some reason the OIR process cannot be completed, the OIR Ready LED will continue blinking. If this occurs, you should check the log and console messages for a failure reason.

If the card is not removed within five minutes, the PRP resets itself and the OIR Ready LED will stop glowing.

The OIR process operates as described even if the PRP is not in a redundant configuration or if the standby PRP is not ready.

Control and Management Ports

Two Control Ethernet optical ports (CNTL ETH 0, CNTL ETH 1) provide connectivity to network control systems. These ports use small form-factor pluggable (SFP or SFP+) modules to provide external Gigabit Ethernet (GE) or 10-Gigabit Ethernet (10-GE) connections.

A Management RJ45 port (MGMT ETH) provides connectivity to network management systems.

Console and Aux Ports

[Table 6-1](#) lists the pinouts for the Console (CON) and Auxiliary (AUX) RJ45 ports on the PRP (items 4 and 5 in [Figure 6-9](#)).

Table 6-1 Pinouts for Console and Aux Ports

Pin	Console Port	Aux Port
1	Request to send (RTS)	Request to send (RTS)
2	Data terminal ready (DTR)	Data terminal ready (DTR)
3	Transmit data (TxD)	Transmit data (TxD)
4	EMI Filter Ground (Gnd Console)	EMI Filter Ground (Gnd Aux)
5	EMI Filter Ground (Gnd Console)	EMI Filter Ground (Gnd Aux)
6	Receive data (RxD)	Receive data (RxD)
7	Carrier detect (CD)	Carrier detect (CD)
8	Clear to send (CTS)	Clear to send (CTS)

Service Ethernet Port

PRP functions include a Service Ethernet feature that enhances serviceability and troubleshooting of the system. The Service Ethernet RJ45 port provides a backdoor mechanism into the PRP if the main CPU subsystem is stuck and cannot be recovered.

Through the Service Ethernet connection, you can perform the follow functions:

- Reset any cards in the chassis, including the local PRP
- Perform console attachment to other CPUs to support console tunneling in the chassis
- Dump memory or device registers on the PRP

USB Port

The PRP has an external USB port on the faceplate for connecting a USB 2.0 thumb flash drive. The external devices connected to this port can be used for logging, external file transfer, and installing software packages.