



Virtual Private Network Configuration Guide for Cisco CRS Series Routers, IOS XR Release 6.7.x

First Published: 2020-08-01

Americas Headquarters

Cisco Systems, Inc.
170 West Tasman Drive
San Jose, CA 95134-1706
USA
<http://www.cisco.com>
Tel: 408 526-4000
800 553-NETS (6387)
Fax: 408 527-0883

THE SPECIFICATIONS AND INFORMATION REGARDING THE PRODUCTS IN THIS MANUAL ARE SUBJECT TO CHANGE WITHOUT NOTICE. ALL STATEMENTS, INFORMATION, AND RECOMMENDATIONS IN THIS MANUAL ARE BELIEVED TO BE ACCURATE BUT ARE PRESENTED WITHOUT WARRANTY OF ANY KIND, EXPRESS OR IMPLIED. USERS MUST TAKE FULL RESPONSIBILITY FOR THEIR APPLICATION OF ANY PRODUCTS.

THE SOFTWARE LICENSE AND LIMITED WARRANTY FOR THE ACCOMPANYING PRODUCT ARE SET FORTH IN THE INFORMATION PACKET THAT SHIPPED WITH THE PRODUCT AND ARE INCORPORATED HEREIN BY THIS REFERENCE. IF YOU ARE UNABLE TO LOCATE THE SOFTWARE LICENSE OR LIMITED WARRANTY, CONTACT YOUR CISCO REPRESENTATIVE FOR A COPY.

The Cisco implementation of TCP header compression is an adaptation of a program developed by the University of California, Berkeley (UCB) as part of UCB's public domain version of the UNIX operating system. All rights reserved. Copyright © 1981, Regents of the University of California.

NOTWITHSTANDING ANY OTHER WARRANTY HEREIN, ALL DOCUMENT FILES AND SOFTWARE OF THESE SUPPLIERS ARE PROVIDED "AS IS" WITH ALL FAULTS. CISCO AND THE ABOVE-NAMED SUPPLIERS DISCLAIM ALL WARRANTIES, EXPRESSED OR IMPLIED, INCLUDING, WITHOUT LIMITATION, THOSE OF MERCHANTABILITY, FITNESS FOR A PARTICULAR PURPOSE AND NON-INFRINGEMENT OR ARISING FROM A COURSE OF DEALING, USAGE, OR TRADE PRACTICE.

IN NO EVENT SHALL CISCO OR ITS SUPPLIERS BE LIABLE FOR ANY INDIRECT, SPECIAL, CONSEQUENTIAL, OR INCIDENTAL DAMAGES, INCLUDING, WITHOUT LIMITATION, LOST PROFITS OR LOSS OR DAMAGE TO DATA ARISING OUT OF THE USE OR INABILITY TO USE THIS MANUAL, EVEN IF CISCO OR ITS SUPPLIERS HAVE BEEN ADVISED OF THE POSSIBILITY OF SUCH DAMAGES.

Any Internet Protocol (IP) addresses and phone numbers used in this document are not intended to be actual addresses and phone numbers. Any examples, command display output, network topology diagrams, and other figures included in the document are shown for illustrative purposes only. Any use of actual IP addresses or phone numbers in illustrative content is unintentional and coincidental.

All printed copies and duplicate soft copies of this document are considered uncontrolled. See the current online version for the latest version.

Cisco has more than 200 offices worldwide. Addresses and phone numbers are listed on the Cisco website at www.cisco.com/go/offices.

The documentation set for this product strives to use bias-free language. For purposes of this documentation set, bias-free is defined as language that does not imply discrimination based on age, disability, gender, racial identity, ethnic identity, sexual orientation, socioeconomic status, and intersectionality. Exceptions may be present in the documentation due to language that is hardcoded in the user interfaces of the product software, language used based on standards documentation, or language that is used by a referenced third-party product.

Cisco and the Cisco logo are trademarks or registered trademarks of Cisco and/or its affiliates in the U.S. and other countries. To view a list of Cisco trademarks, go to this URL: <https://www.cisco.com/c/en/us/about/legal/trademarks.html>. Third-party trademarks mentioned are the property of their respective owners. The use of the word partner does not imply a partnership relationship between Cisco and any other company. (1721R)

© 2020 Cisco Systems, Inc. All rights reserved.



CONTENTS

PREFACE

Preface xiii

Changes to This Document xiii

Obtaining Documentation and Submitting a Service Request xiii

CHAPTER 1

The Carrier Ethernet Model 1

Ethernet Flow Point 1

EFP CLI Overview 2

CHAPTER 2

Implementing Point to Point Layer 2 services 3

Prerequisites for Implementing Point to Point Layer 2 Services 4

Information About Implementing Point to Point Layer 2 Services 4

L2VPN Overview 4

ATMoMPLS with L2VPN Capability 4

ATMoMPLS with L2VPN Overview 4

Layer 2 Local Switching Overview 5

ATM Adaptation Layer 5 5

Virtual Circuit Connection Verification on L2VPN 5

Ethernet over MPLS 5

Ethernet Port Mode 6

Ethernet Remote Port Shutdown 6

VLAN Mode 6

Inter-AS Mode 7

QinQ Mode 8

QinAny Mode 9

Quality of Service 9

High Availability 10

- Preferred Tunnel Path 10
- Generic Routing Encapsulation Support for L2VPN 11
 - Ethernet over MPLS Forwarding Using GRE Tunnels 11
 - Limitations 11
- Pseudowire Redundancy 12
- Flow Aware Transport Pseudowire (FAT PW) 12
- Any Transport over MPLS 13
 - Control Word Processing 14
- L2VPN Nonstop Routing 14
- How to Implement Point to Point Layer 2 Services 14
 - Configuring an Interface or Connection for Point to Point Layer 2 Services 14
 - Configuring Static Point-to-Point Cross-Connects 16
 - Configuring Dynamic Point-to-Point Cross-Connects 18
 - Configuring Inter-AS 20
 - Configuring L2VPN Quality of Service 20
 - Restrictions 20
 - Configuring an L2VPN Quality of Service Policy in Port Mode 20
 - Configuring an L2VPN Quality of Service Policy in VLAN Mode 21
 - Configuring Preferred Tunnel Path 22
 - Enabling Load Balancing with ECMP and FAT PW 23
 - Configuring L2VPN Nonstop Routing 24
 - Configure MPLS LDP Nonstop Routing 26
- Configuration Examples for Point to Point Layer 2 Services 27
 - L2VPN Interface Configuration: Example 27
 - Point-to-Point Cross-connect Configuration: Examples 27
 - Inter-AS: Example 27
 - L2VPN Quality of Service: Example 29
 - Preferred Path: Example 29
 - Enabling Load Balancing with FAT PW: Example 29
 - AToM Cross Connect Configuration: Example 30
 - Configuring L2VPN over GRE Tunnels: Example 31
 - Configuring L2VPN Nonstop Routing: Example 32

CHAPTER 3 **Implementing MPLS VPNs over IP Tunnels 33**

Prerequisites for Configuring MPLS VPNs over IP Tunnels	33
Restrictions for Configuring MPLS VPNs over IP Tunnels	34
Information About MPLS VPNs over IP Tunnels	34
Overview: MPLS VPNs over IP Tunnels	34
Advertising Tunnel Type and Tunnel Capabilities Between PE Routers—BGP	34
PE Routers and Address Space	35
Packet Validation Mechanism	35
Quality of Service Using the Modular QoS CLI	35
BGP Multipath Load Sharing for MPLS VPNs over IP Tunnels	36
Inter-AS over IP Tunnels	36
Multiple Tunnel Source Address	36
6PE/6VPE over L2TPv3	37
How to Configure MPLS VPNs over IP Tunnels	38
Configuring the Global VRF Definition	38
Configuring a Route-Policy Definition	40
Configuring a Static Route	41
Configuring an IPv4 Loopback Interface	42
Configuring a CFI VRF Interface	43
Configuring the Core Network	44
Configuring Inter-AS over IP Tunnels	45
Configuring the ASBRs to Exchange VPN-IPv4 Addresses for IP Tunnels	45
Configuring the Backbone Carrier Core for IP Tunnels	48
Verifying MPLS VPN over IP	48
Configuring Source Pool Address for MPLS VPNs over IP Tunnels	48
Configuration Examples for MPLS VPNs over IP Tunnels	50
Configuring an L2TPv3 Tunnel: Example	50
Configuring the Global VRF Definition: Example	50
Configuring a Route-Policy Definition: Example	51
Configuring a Static Route: Example	51
Configuring an IPv4 Loopback Interface: Example	51
Configuring a CFI VRF Interface: Example	51
Configuring Source Pool Address for MPLS VPNs over IP Tunnels: Example	51

Prerequisites for Implementing Multipoint Layer 2 Services	54
Restrictions for Implementing Multipoint Layer 2 Services	54
Information About Implementing Multipoint Layer 2 Services	55
Multipoint Layer 2 Services Overview	55
VPLS for an MPLS-based Provider Core	56
Hierarchical VPLS	56
VPLS Discovery and Signaling	57
BGP-based VPLS Autodiscovery	58
BGP Auto Discovery With BGP Signaling	58
BGP Auto Discovery With LDP Signaling	59
Interoperability Between Cisco IOS XR and Cisco IOS on VPLS LDP Signaling	60
Bridge Domain	60
MAC Address-related Parameters	60
MAC Address Flooding	61
MAC Address-based Forwarding	61
MAC Address Source-based Learning	61
MAC Address Aging	61
MAC Address Limit	62
MAC Address Withdrawal	63
LSP Ping over VPWS and VPLS	63
VPLS Scalability and Performance Targets	64
Pseudowire Redundancy for P2P AToM Cross-Connects	64
Pseudowire Headend	64
PWHE Interfaces	65
Pseudowire Grouping	65
How to Implement Multipoint Layer 2 Services	66
Configuring a Bridge Domain	66
Creating a Bridge Domain	66
Configuring a Pseudowire	67
Enabling Pseudowire Status TLV	69
Configuring a Backup Pseudowire	70
Configuring Backup Disable Delay	71
Associating Members with a Bridge Domain	73
Configuring Bridge Domain Parameters	75

Disabling a Bridge Domain	77
Configuring a Layer 2 Virtual Forwarding Instance	78
Creating the Virtual Forwarding Instance	78
Associating Pseudowires with the Virtual Forwarding Instance	79
Associating a Virtual Forwarding Instance to a Bridge Domain	81
Attaching Pseudowire Classes to Pseudowires	83
Configuring Pseudowires Using Static Labels	84
Disabling a Virtual Forwarding Instance	86
Configuring the MAC Address-related Parameters	88
Configuring the MAC Address Source-based Learning	88
Disabling the MAC Address Withdrawal	90
Configuring the MAC Address Limit	92
Configuring the MAC Address Aging	95
Disabling MAC Flush at the Bridge Port Level	97
Configuring VPLS with BGP Autodiscovery and Signaling	98
Configuring VPLS with BGP Autodiscovery and LDP Signaling	102
Configuring Pseudowire Headend	105
PWHE Configuration Restrictions	105
Configuring PWHE Interfaces	106
Configuring PWHE Interface Parameters	107
Configuring PWHE Crossconnect	109
Enabling Pseudowire Grouping	110
Configuration Examples for Multipoint Layer 2 Services	111
Multipoint Layer 2 Services Configuration for Provider Edge-to-Provider Edge: Example	111
Multipoint Layer 2 Services Configuration for Provider Edge-to-Customer Edge: Example	112
Configuring Backup Disable Delay: Example	112
Disabling MAC Flush: Examples	113
H-VPLS Configuration: Examples	114
VPLS with QinQ or QinAny: Example	114
H-VPLS with Access-PWs: Example	115
Configuring VPLS with BGP Autodiscovery and Signaling: Example	116
LDP and BGP Configuration	116
Minimum L2VPN Configuration for BGP Autodiscovery with BGP Signaling	117
VPLS with BGP Autodiscovery and BGP Signaling	117

Minimum Configuration for BGP Autodiscovery with LDP Signaling 119

VPLS with BGP Autodiscovery and LDP Signaling 119

Configuring Pseudowire Headend: Example 121

Enabling Pseudowire Grouping: Example 123

CHAPTER 5

Implementing IPv6 VPN Provider Edge Transport over MPLS 125

Prerequisites for Implementing 6PE/VPE 125

Information About 6PE/VPE 126

Overview of 6PE/VPE 126

Benefits of 6PE/VPE 126

IPv6 on the Provider Edge and Customer Edge Routers 127

IPv6 Provider Edge Multipath 127

OSPFv3 6VPE 128

Multiple VRF Support 128

OSPFv3 PE-CE Extensions 128

VRF Lite 128

How to Implement 6PE/VPE 129

Configuring 6PE/VPE 129

Configuring PE to PE Core 131

Configuring OSPFv3 as the Routing Protocol Between the PE and CE Routers 134

Configuration Examples for 6PE/VPE 137

Configuring 6PE on a PE Router: Example 137

Configuring OSPFv3 6VPE: Example 138

CHAPTER 6

Implementing Layer 2 Tunnel Protocol Version 3 139

Prerequisites for Layer 2 Tunnel Protocol Version 3 139

Information About Layer 2 Tunnel Protocol Version 3 140

L2TPv3 Operation 140

L2TPv3 Benefits 140

L2TPv3 Features 141

Static L2TPv3 Sessions 141

Dynamic L2TPv3 Sessions 142

Local Switching 142

Local Switching: Quality of Service 143

L2TPv3 Pseudowire Switching	143
L2TPv3 Pseudowire Manager	143
IP Packet Fragmentation	143
L2TPv3 Type of Service Marking	144
Keepalive	144
Maximum Transmission Unit Handling	144
IP Security Mapping to L2 Tunneling Protocol, Version 3	145
Like-to-Like Pseudowires	145
How to Implement Layer 2 Tunnel Protocol Version 3	146
Configuring a Pseudowire Class	146
Configuring L2TP Control-Channel Parameters	147
Configuring L2TP Control-Channel Timing Parameters	148
Configuring L2TPv3 Control-Channel Authentication Parameters	149
Configuring L2TP Control-Channel Maintenance Parameters	156
Configuring L2TPv3 Pseudowires	156
Configuring a Dynamic L2TPv3 Pseudowire	156
Configuring a Static L2TPv3 Pseudowire	158
Configuration Examples for Layer 2 Tunnel Protocol Version 3	162
Configuring an L2TP Class for L2TPv3-based L2VPN PE Routers: Example	162
Configuring a Pseudowire Class: Example	162
Configuring L2TPv3 Control Channel Parameters: Example	162
Configuring an Interface for Layer 2 Transport Mode: Example	162

CHAPTER 7**Implementing MPLS Layer 3 VPNs 165**

Prerequisites for Implementing MPLS L3VPN	166
MPLS L3VPN Restrictions	167
Information About MPLS Layer 3 VPNs	167
MPLS L3VPN Overview	167
MPLS L3VPN Benefits	168
How MPLS L3VPN Works	169
Virtual Routing and Forwarding Tables	169
VPN Routing Information: Distribution	169
BGP Distribution of VPN Routing Information	170
MPLS Forwarding	170

Automatic Route Distinguisher Assignment	171
MPLS L3VPN Major Components	171
Inter-AS Support for L3VPN	171
Inter-AS Restrictions	171
Inter-AS Support: Overview	171
Inter-AS and ASBRs	172
Transmitting Information Between Autonomous Systems	173
Exchanging VPN Routing Information	174
Packet Forwarding	176
Confederations	179
MPLS VPN Inter-AS BGP Label Distribution	181
Exchanging IPv4 Routes with MPLS labels	181
BGP Routing Information	182
BGP Messages and MPLS Labels	182
Sending MPLS Labels with Routes	183
Generic Routing Encapsulation Support for L3VPN	183
GRE Restriction for L3VPN	183
VPNv4 Forwarding Using GRE Tunnels	183
Ingress of Encapsulation Router	184
Egress of Encapsulation Router	184
Ingress of Decapsulation Router	184
Egress of Decapsulation Router	184
Carrier Supporting Carrier Support for L3VPN	184
CSC Prerequisites	185
CSC Benefits	185
Configuration Options for the Backbone and Customer Carriers	185
Customer Carrier: ISP with IP Core	186
Customer Carrier: MPLS Service Provider	186
IPv6 VPN Provider Edge (6VPE) Support	187
6VPE Benefits	187
6VPE Network Architecture	187
Dual Stack	188
6VPE Operation	188
How to Implement MPLS Layer 3 VPNs	189

Configuring the Core Network	189
Assessing the Needs of MPLS VPN Customers	189
Configuring Routing Protocols in the Core	190
Configuring MPLS in the Core	190
Determining if FIB Is Enabled in the Core	190
Configuring Multiprotocol BGP on the PE Routers and Route Reflectors	190
Connecting MPLS VPN Customers	191
Defining VRFs on the PE Routers to Enable Customer Connectivity	191
Configuring VRF Interfaces on PE Routers for Each VPN Customer	194
Configuring BGP as the Routing Protocol Between the PE and CE Routers	195
Configuring RIPv2 as the Routing Protocol Between the PE and CE Routers	199
Configuring Static Routes Between the PE and CE Routers	201
Configuring OSPF as the Routing Protocol Between the PE and CE Routers	203
Configuring EIGRP as the Routing Protocol Between the PE and CE Routers	205
Configuring EIGRP Redistribution in the MPLS VPN	208
Providing VPN Connectivity Across Multiple Autonomous Systems with MPLS VPN Inter-AS with ASBRs Exchanging IPv4 Routes and MPLS Labels	209
Configuring ASBRs to Exchange IPv4 Routes and MPLS Labels	209
Configuring the Route Reflectors to Exchange VPN-IPv4 Routes	212
Configuring the Route Reflector to Reflect Remote Routes in its AS	214
Providing VPN Connectivity Across Multiple Autonomous Systems with MPLS VPN Inter-AS with ASBRs Exchanging VPN-IPv4 Addresses	217
Configuring the ASBRs to Exchange VPN-IPv4 Addresses for IP Tunnels	217
Configuring a Static Route to an ASBR Peer	220
Configuring EBGW Routing to Exchange VPN Routes Between Subautonomous Systems in a Confederation	221
Configuring MPLS Forwarding for ASBR Confederations	224
Configuring a Static Route to an ASBR Confederation Peer	225
Configuring Carrier Supporting Carrier	226
Identifying the Carrier Supporting Carrier Topology	226
Configuring the Backbone Carrier Core	227
Configuring the CSC-PE and CSC-CE Routers	227
Configuring a CSC-PE	228
Configuring PE to CE Core	231
Configuring a Static Route to a Peer	234

Verifying the MPLS Layer 3 VPN Configuration	236
Configuring L3VPN over GRE	239
Creating a GRE Tunnel between Provider Edge Routers	239
Configuring IGP between Provider Edge Routers	241
Configuring LDP/GRE on the Provider Edge Routers	243
Configuring L3VPN	245
Configuring 6VPE Support	251
Configuring an IPv6 Address Family Under VRF	251
Configuring BGP Route Distinguisher and Core-facing Sessions	252
Configuring a PE-CE Protocol	254
Configuration Examples for Implementing MPLS Layer 3 VPNs	256
Configuring an MPLS VPN Using BGP: Example	256
Configuring the Routing Information Protocol on the PE Router: Example	257
Configuring the PE Router Using EIGRP: Example	258
Configuration Examples for MPLS VPN CSC	258
Configuring the Backbone Carrier Core: Examples	258
Configuring the Links Between CSC-PE and CSC-CE Routers: Examples	258
Configuring a Static Route to a Peer: Example	259
Configuring L3VPN over GRE: Example	260
Configuration Examples for 6VPE	262
Configuring an IPv6 Address Family Under VRF: Example	262
Configuring BGP for the Address Family VPNv6: Example	263
Configuring the Address Family IPv6 for the VRF Configuration Under BGP: Example	263
Configuring a PE-CE Protocol: Example	263
Configuring an Entire 6VPE Configuration: Example	263



Preface



Note This product has reached end-of-life status. For more information, see the [End-of-Life and End-of-Sale Notices](#).

This guide describes the Cisco CRS Router configurations. The preface for the contains these sections:

- [Changes to This Document, on page xiii](#)
- [Obtaining Documentation and Submitting a Service Request, on page xiii](#)

Changes to This Document

The following table lists the technical changes made to this document since it was first published.

Date	Change Summary
August 2020	Initial release of this document.

Obtaining Documentation and Submitting a Service Request

For information on obtaining documentation, submitting a service request, and gathering additional information, see the monthly What's New in Cisco Product Documentation, which also lists all new and revised Cisco technical documentation, at:

<http://www.cisco.com/en/US/docs/general/whatsnew/whatsnew.html>

Subscribe to the What's New in Cisco Product Documentation as a Really Simple Syndication (RSS) feed and set content to be delivered directly to your desktop using a reader application. The RSS feeds are a free service and Cisco currently supports RSS version 2.0.



CHAPTER 1

The Carrier Ethernet Model

This module provides the conceptual information for Implementing Ethernet Flow Points (EFPs).

Table 1: Feature History for Implementing Ethernet Flow Point

Release	Modification
Release 5.1.1	The EFP model was introduced on the Cisco CRS Router

- [Ethernet Flow Point, on page 1](#)
- [EFP CLI Overview, on page 2](#)

Ethernet Flow Point

An Ethernet Flow Point (EFP) is a Layer 2 logical subinterface used to classify traffic under a physical or a bundle interface. A physical interface can be an Ethernet interface and has ports on the line card.

A bundle interface is a virtual interface, created by grouping physical interfaces together. For example, physical interfaces such as 10 Gigabit Ethernet 0/0/0/1 and 10 Gigabit Ethernet 0/0/0/0 can be configured as members of a bundle interface.

Grouping physical interfaces together can:

- Reduce the routing entries.
- Increase the bandwidth of the bundle interface.
- Balance the traffic on the bundle members.

EFP has the following characteristics:

- An EFP represents a logical demarcation point of an Ethernet Virtual Connection (EVC) on an interface. For an EVC associating two or more UNIs, there is a flow point on each interface of every device, through which that EVC passes.
- An EFP can be regarded as an instantiation of a particular service. An EFP is defined by a set of filters. These filters are applied to all the ingress traffic to classify the frames that belong to a particular EFP. An EFP filter is a set of entries, where each entry looks similar to the start of a packet (ignoring source/destination MAC address). Each entry usually contains 0, 1 or 2 VLAN tags. A packet that starts with the same tags as an entry in the filter is said to match the filter; if the start of the packet does not correspond to any entry in the filter then the packet does not match the filter.

- An EFP serves four purposes:
 - Identifies all frames that belong to a particular flow on a given interface
 - Performs ingress and egress Ethernet header manipulations
 - Adds features to the identified frames
 - Optionally define how to forward those frames in the data path.

You can perform a variety of operations on the traffic flows when a router is configured with EFPs on various interfaces. Also, you can bridge or tunnel the traffic by many ways from one or more of the router's ingress EFPs to one or more egress EFPs. This traffic is a mixture of VLAN IDs, single or double (QinQ) encapsulation, and ethertypes.

The following figure shows the EFP model.

Figure 1: EFP Model

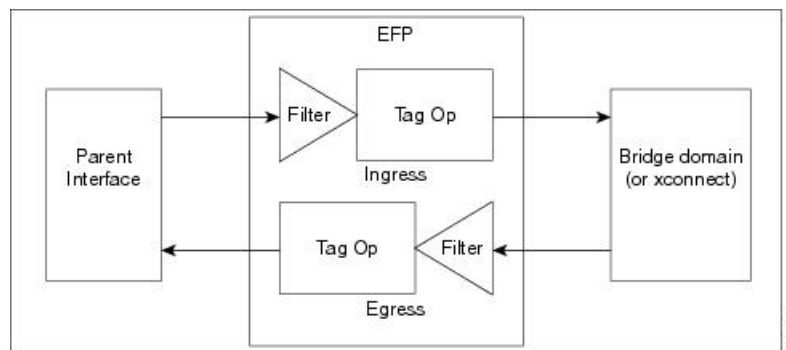

An EFP subinterface is configured to specify which traffic on ingress is vectored to that EFP. This is done by specifying a VLAN ID or QinQ tagging to match against on ingress. All traffic on ingress is compared to each EFP's matching criterion, and processed by that EFP if a match occurs. The processing performed by an EFP can change VLAN IDs, add or remove VLAN tags, and change ethertypes.

EFP CLI Overview

The following commands are typically used to configure an EFP:

- **l2transport** command - This command identifies a subinterface (or a physical port or bundle-port parent interface) as an EFP.
- **encapsulation** command - This command is used to specify matching criteria.
- **rewrite** command - This command is used to specify the VLAN tag rewrite criteria.



CHAPTER 2

Implementing Point to Point Layer 2 services

This module provides the conceptual and configuration information for Point to Point Layer 2 services on Cisco IOS XR software.



Note The Point to Point Layer 2 services are also called as MPLS Layer 2 VPNs.

Feature History for Implementing Point to Point Layer 2 services Configuration Module

Release	Modification
Release 3.4.0	This feature was introduced.
Release 3.4.1	Support was added for: <ul style="list-style-type: none">• Virtual Circuit Connection Verification (VCCV) on L2VPN• Layer 2 VPN (L2VPN) Quality of Service (QoS) for Ethernet-over-MPLS (EoMPLS)
Release 3.5.0	Support was added for: <ul style="list-style-type: none">• EoMPLS Inter-AS mode• Mac-in-Mac protocol
Release 3.6.0	Support was added for: <ul style="list-style-type: none">• Ethernet Remote Port Shutdown• Preferred Tunnel Path
Release 3.7.0	Support was added for ATM over MPLS (ATMoMPLS) with Layer 2VPN capability.
Release 3.8.0	Support was added for QinQ mode and QinAny mode for EoMPLS.
Release 3.9.0	Support was added for the Generic Routing Encapsulation (GRE) feature.
Release 4.2.0	Support was added for the Load Balancing with Flow Aware Transport pseudowires (FAT PW) feature.

- [Prerequisites for Implementing Point to Point Layer 2 Services, on page 4](#)
- [Information About Implementing Point to Point Layer 2 Services, on page 4](#)

- [How to Implement Point to Point Layer 2 Services, on page 14](#)
- [Configuration Examples for Point to Point Layer 2 Services , on page 27](#)

Prerequisites for Implementing Point to Point Layer 2 Services

To perform these configuration tasks, your Cisco IOS XR software system administrator must assign you to a user group associated with a task group that includes the corresponding command task IDs. All command task IDs are listed in individual command references and in the *Cisco IOS XR Task ID Reference Guide*.

If you need assistance with your task group assignment, contact your system administrator.

Information About Implementing Point to Point Layer 2 Services

To implement Point to Point Layer 2 Services, you should understand these concepts:

L2VPN Overview

Layer 2 VPN (L2VPN) emulates the behavior of a LAN across an IP or MPLS-enabled IP network allowing Ethernet devices to communicate with each other as they would when connected to a common LAN segment.

As Internet service providers (ISPs) look to replace their Asynchronous Transfer Mode (ATM) infrastructures with an IP infrastructure, there is a need for to provide standard methods of using an IP infrastructure to provide a serviceable L2 interface to customers; specifically, to provide standard ways of using an IP infrastructure to provide virtual circuits between pairs of customer sites.

Building a L2VPN system requires coordination between the ISP and the customer. The ISP provides L2 connectivity; the customer builds a network using data link resources obtained from the ISP. In an L2VPN service, the ISP does not require information about a the customer's network topology, policies, routing information, point-to-point links, or network point-to-point links from other ISPs.

The ISP requires provider edge (PE) routers with the following capabilities:

- Encapsulation of L2 protocol data units (PDU) into Layer 3 (L3) packets.
- Interconnection of any-to-any L2 transports.
- Emulation of L2 quality-of-service (QoS) over a packet switch network.
- Ease of configuration of the L2 service.
- Support for different types of tunneling mechanisms (MPLS, L2TPv3, IPSec, GRE, and others).
- L2VPN process databases include all information related to circuits and their connections.

ATMoMPLS with L2VPN Capability

These topics describe the ATM over MPLS (ATMoMPLS) with L2VPN feature:

ATMoMPLS with L2VPN Overview

The ATMoMPLS feature supports ATM Adaptation Layer 5 (AAL5) transport. ATMoMPLS is a type of Layer 2 point-to-point connection over an MPLS core. ATMoMPLS and ATM local switching are supported only for ATM-to-ATM interface-to-interface switching combinations.

To implement the ATMoMPLS feature, the Cisco CRS Router plays the role of provider edge (PE) router at the edge of a provider network in which customer edge (CE) devices are connected to the Cisco CRS Router.

Layer 2 Local Switching Overview

Local switching lets you to switch Layer 2 data between two interfaces of the same type (for example, ATM-to-ATM, or Frame Relay-to-Frame Relay) or between interfaces of different types (for example, Frame Relay to ATM) on the same router, over an IP core network. The interfaces are on the same line card or on two different cards. During these types of switching, Layer 2 address is used instead of the Layer 3 address.

In addition, same-port local switching lets you to switch Layer 2 data between two circuits on the same interface.

ATM Adaptation Layer 5

AAL5 lets you transport AAL5 PDUs from various customers over an MPLS backbone. ATM AAL5 extends the usability of the MPLS backbone by enabling it to offer Layer 2 services in addition to already existing Layer 3 services. You can enable the MPLS backbone network to accept AAL5 PDUs by configuring the provider edge (PE) routers at both ends of the MPLS backbone.

To transport AAL5 PDUs over MPLS, a virtual circuit is set up from the ingress PE router to the egress PE router. This virtual circuit transports the AAL5 PDUs from one PE router to the other. Each AAL5 PDU is transported as a single packet.

Virtual Circuit Connection Verification on L2VPN

Virtual Circuit Connection Verification (VCCV) is an L2VPN Operations, Administration, and Maintenance (OAM) feature that allows network operators to run IP-based provider edge-to-provider edge (PE-to-PE) keepalive protocol across a specified pseudowire to ensure that the pseudowire data path forwarding does not contain any faults. The disposition PE receives VCCV packets on a control channel, which is associated with the specified pseudowire. The control channel type and connectivity verification type, which are used for VCCV, are negotiated when the pseudowire is established between the PEs for each direction.

Two types of packets can arrive at the disposition egress:

- Type 1—Specifies normal Ethernet-over-MPLS (EoMPLS) data packets.
- Type 2—Specifies VCCV packets.

Cisco CRS Router supports Label Switched Path (LSP) VCCV Type 1, which uses an inband control word if enabled during signaling. The VCCV echo reply is sent as IPv4 that is the reply mode in IPv4. The reply is forwarded as IP, MPLS, or a combination of both.

VCCV pings counters that are counted in MPLS forwarding on the egress side. However, on the ingress side, they are sourced by the route processor and do not count as MPLS forwarding counters.

Ethernet over MPLS

Ethernet-over-MPLS (EoMPLS) provides a tunneling mechanism for Ethernet traffic through an MPLS-enabled L3 core and encapsulates Ethernet protocol data units (PDUs) inside MPLS packets (using label stacking) to forward them across the MPLS network.

EoMPLS features are described in these subsections:

Ethernet Port Mode

In Ethernet port mode, both ends of a pseudowire are connected to Ethernet ports. In this mode, the port is tunneled over the pseudowire or, using local switching (also known as an *attachment circuit-to-attachment circuit cross-connect*) switches packets or frames from one attachment circuit (AC) to another AC attached to the same PE node.



Note L2VPN forwarding using GRE tunnels is supported in the Ethernet port mode.

The following figure provides an example of Ethernet port mode.

Figure 2: Ethernet Port Mode Packet Flow

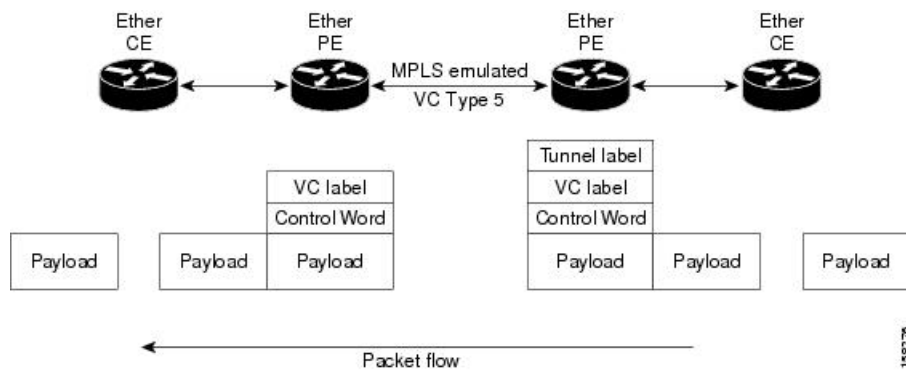

Ethernet Remote Port Shutdown

Ethernet remote port shutdown provides a mechanism for the detection and propagation of remote link failure for port mode EoMPLS on a Cisco CRS Router line card. This lets a service provider edge router on the local end of an Ethernet-over-MPLS (EoMPLS) pseudowire detect a cross-connect or remote link failure and cause the shutdown of the Ethernet port on the local customer edge router. Shutting down the Ethernet port on the local customer edge router prevents or mitigates a condition where that router would otherwise lose data by forwarding traffic continuously to the remote failed link, especially if the link were configured as a static IP route (see following figure)..

Figure 3: Remote Link Outage in EoMPLS Wide Area Network

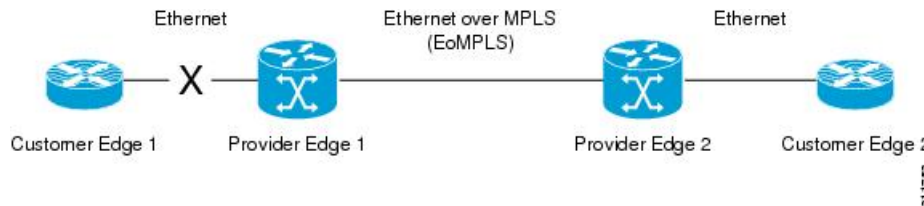

To enable this functionality, see the **I2transport propagate** command in *MPLS Command Reference for the Cisco CRS Router*.

VLAN Mode

In VLAN mode, each VLAN on a customer-end to provider-end link can be configured as a separate L2VPN connection using virtual connection (VC) type 4 or VC type 5. VC type 4 is the default mode.

As illustrated in the following figure, the Ethernet PE associates an internal VLAN-tag to the Ethernet port for switching the traffic internally from the ingress port to the pseudowire; however, before moving traffic into the pseudowire, it removes the internal VLAN tag.

Figure 4: VLAN Mode Packet Flow

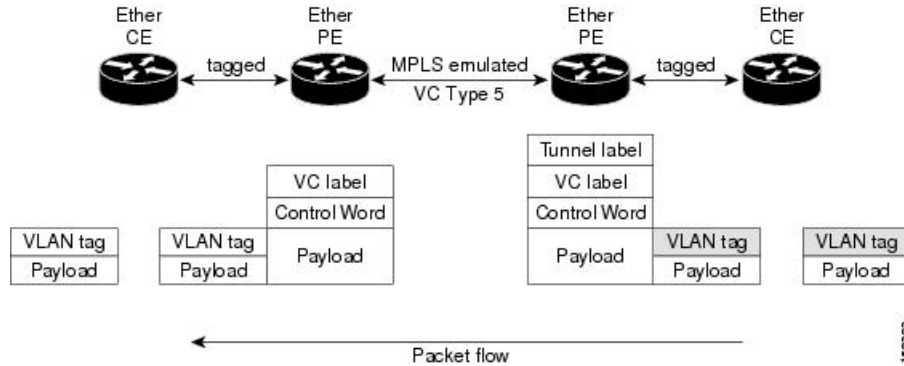

At the egress VLAN PE, the PE associates a VLAN tag to the frames coming off of the pseudowire and after switching the traffic internally, it sends out the traffic on an Ethernet trunk port.



Note Because the port is in trunk mode, the VLAN PE doesn't remove the VLAN tag and forwards the frames through the port with the added tag.



Note L2VPN forwarding using GRE tunnels is supported in the VLAN mode.

Inter-AS Mode

Inter-AS is a peer-to-peer type model that allows extension of VPNs through multiple provider or multi-domain networks. This lets service providers peer up with one another to offer end-to-end VPN connectivity over extended geographical locations.

EoMPLS support can assume a single AS topology where the pseudowire connecting the PE routers at the two ends of the point-to-point EoMPLS cross-connects resides in the same autonomous system; or multiple AS topologies in which PE routers can reside on two different ASs using iBGP and eBGP peering.

The following figure illustrates MPLS over Inter-AS with a basic double AS topology with iBGP/LDP in each AS.

Figure 5: EoMPLS over Inter-AS: Basic Double AS Topology

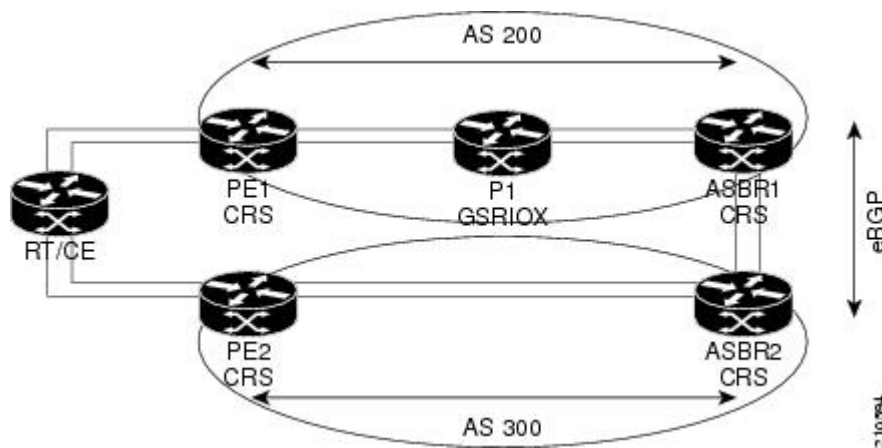

QinQ Mode

QinQ is an extension of 802.1Q for specifying multiple 802.1Q tags (IEEE 802.1QinQ VLAN Tag stacking). Layer 3 VPN service termination and L2VPN service transport are enabled over QinQ sub-interfaces.

The Cisco CRS Routers implement the Layer 2 tunneling or Layer 3 forwarding depending on the subinterface configuration at provider edge routers. This function only supports up to two QinQ tags on the SPA and fixed PLIM:

- Layer 2 QinQ VLANs in L2VPN attachment circuit: QinQ L2VPN attachment circuits are configured under the Layer 2 transport subinterfaces for point-to-point EoMPLS based cross-connects using both virtual circuit type 4 and type 5 pseudowires and point-to-point local-switching-based cross-connects including full interworking support of QinQ with 802.1q VLANs and port mode.
- Layer 3 QinQ VLANs: Used as a Layer 3 termination point, both VLANs are removed at the ingress provider edge and added back at the remote provider edge as the frame is forwarded.

Layer 3 services over QinQ include:

- IPv4 unicast and multicast
- IPv6 unicast and multicast
- MPLS
- Connectionless Network Service (CLNS) for use by Intermediate System-to-Intermediate System (IS-IS) Protocol



Note The Cisco CRS-1 router does not support: bundle attachment circuits and Hot Standby Router Protocol (HSRP) or Virtual Router Redundancy Protocol (VRRP) on QinQ subinterfaces.

In QinQ mode, each CE VLAN is carried into an SP VLAN. QinQ mode should use VC type 5, but VC type 4 is also supported. On each Ethernet PE, you must configure both the inner (CE VLAN) and outer (SP VLAN).

The following figure illustrates QinQ using VC type 4.

Figure 6: EoMPLS over QinQ Mode

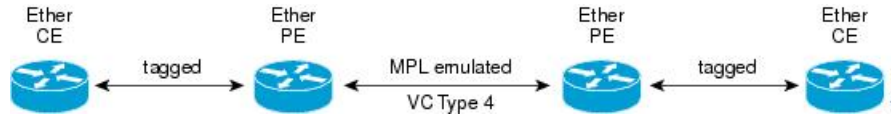

QinAny Mode

In the QinAny mode, the service provider VLAN tag is configured on both the ingress and the egress nodes of the provider edge VLAN. QinAny mode is similar to QinQ mode using a Type 5 VC, except that the customer edge VLAN tag is carried in the packet over the pseudowire, as the customer edge VLAN tag is unknown.

Quality of Service

Using L2VPN technology, you can assign a quality of service (QoS) level to both Port and VLAN modes of operation.

L2VPN technology requires that QoS functionality on PE routers be strictly L2-payload-based on the edge-facing interfaces (also known as *attachment circuits*). The following figure illustrates L2 and L3 QoS service policies in a typical L2VPN network.

Figure 7: L2VPN QoS Feature Application

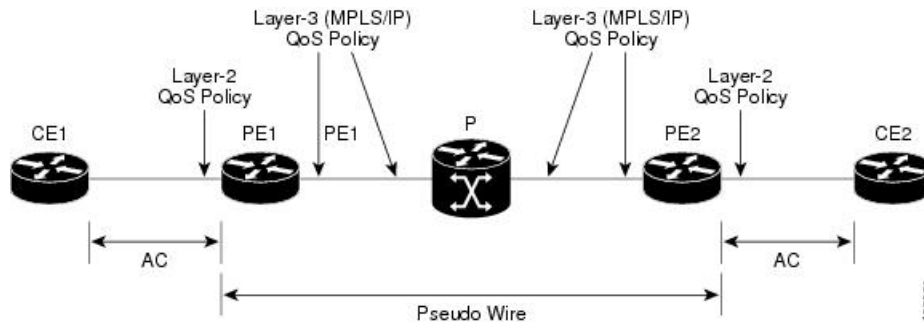

The following figure shows four packet processing paths within a provider edge device where a QoS service policy can be attached. In an L2VPN network, packets are received and transmitted on the edge-facing interfaces as L2 packets and transported on the core-facing interfaces as MPLS (EoMPLS) or IP (L2TP) packets.

Figure 8: L2VPN QoS Reference Model

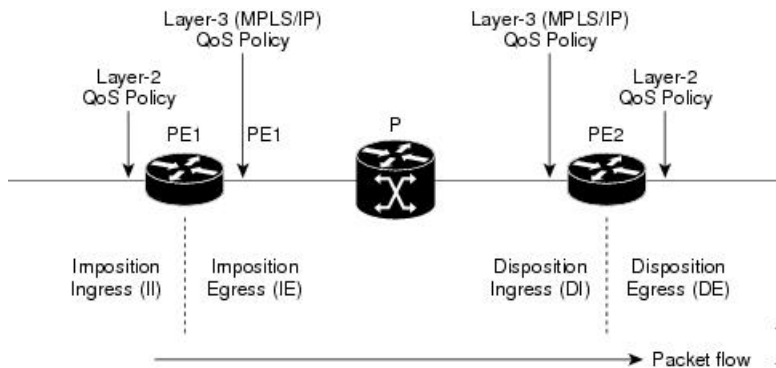

High Availability

L2VPN uses control planes in both route processors and line cards, as well as forwarding plane elements in the line cards.



Note The l2tp_mgr process does not support high availability.

The availability of L2VPN meets these requirements:

- A control plane failure in either the route processor or the line card will not affect the circuit forwarding path.
- The router processor control plane supports failover without affecting the line card control and forwarding planes.
- L2VPN integrates with existing Label Distribution Protocol (LDP) graceful restart mechanism.

Preferred Tunnel Path

Preferred tunnel path functionality lets you map pseudowires to specific traffic-engineering tunnels. Attachment circuits are cross-connected to specific MPLS traffic engineering tunnel interfaces instead of remote PE router IP addresses (reachable using IGP or LDP). Using preferred tunnel path, it is always assumed that the traffic engineering tunnel that transports the L2 traffic runs between the two PE routers (that is, its head starts at the imposition PE router and its tail terminates on the disposition PE router).



Note

- Currently, preferred tunnel path configuration applies only to MPLS encapsulation.
- The fallback enable option is supported.

Generic Routing Encapsulation Support for L2VPN

Generic Routing Encapsulation (GRE) is a tunneling protocol that can encapsulate many types of packets to enable data transmission using a tunnel.

Ethernet over MPLS Forwarding Using GRE Tunnels

This section describes the working of the Ethernet over MPLS (EoMPLS) over GRE tunnels. The following description assumes that the GRE tunnels connect two PE routers, and Layer 2 circuits exist between the PE and CE routers.

Ingress of Encapsulation Router

To enable L2VPN forwarding over GRE tunnels, the targeted Label Distribution Protocol (LDP) neighbor session (established over the GRE tunnel interface) enables exchanging virtual circuit labels between the PE routers. LDP also installs an implicit null label to be used across the GRE tunnels. The implicit null label is a label with special semantics that an LDP can bind to an address prefix. The Layer 2 forwarding tracks the GRE tunnel or addresses, depending on the GRE tunnel.

Egress of Encapsulation Router

On the egress side of the encapsulation PE router, the following events occur:

- The Layer 2 packet passes through the regular L2VPN processing based on the local label imposed by the ingress side.
- The Layer 2 packet is encapsulated with the GRE header and outer IP header.
- The packet is transmitted based on the outer IP header information.

Ingress of Decapsulation Router

When the decapsulation router (remote PE) receives the GRE encapsulated Layer 2 packet, the following events occur:

- The packet is processed based on the outer IP header information.
- The packet is decapsulated to retrieve the inner LDP packet.

Further processing of the packet is based on the Layer 2 payload. The packet is handed over to the egress line card (that hosts the Layer 2 circuit) based on the VC label forwarding information programmed by the Layer 2 FIB.

Egress of Decapsulation Router

On the egress side of the decapsulation router, the following events occur:

- The forwarding occurs based on the Layer 2 VC label on the packet.
- A VC label lookup identifies the correct Layer 2 circuit to be used, to forward the packet towards the CE router that hosts the Layer 2 destination.

Limitations

- Fragmentation and reassembly of GRE packets are not supported.

- At GRE tunnel head end, decision to fragment packet is taken on the basis of Do-Not-Fragment (DF) flag in IPv4 header of the incoming packet. The GRE tunnel DF flag configuration is ignored while fragmenting the packet.
- The configured tunnel GRE DF flag value is inserted into transport header. However, fragmentation of GRE packet is not supported anywhere in the GRE tunnel path.
- The following features are not supported:
 - GRE tunnel in VRF domains
 - Multicast
 - V6 over GRE
 - MPLS/L3VPN over GRE
 - VPNv4 forwarding over GRE tunnels
 - 6PE/6VPE over GRE

Pseudowire Redundancy

Pseudowire redundancy allows you to configure your network to detect a failure in the network and reroute the Layer 2 service to another endpoint that can continue to provide service. This feature provides the ability to recover from a failure of either the remote provider edge (PE) router or the link between the PE and customer edge (CE) routers.

L2VPNs can provide pseudowire resiliency through their routing protocols. When connectivity between end-to-end PE routers fails, an alternative path to the directed LDP session and the user data takes over. However, there are some parts of the network in which this rerouting mechanism does not protect against interruptions in service.

Pseudowire redundancy enables you to set up backup pseudowires. You can configure the network with redundant pseudowires and redundant network elements.

Prior to the failure of the primary pseudowire, the ability to switch traffic to the backup pseudowire is used to handle a planned pseudowire outage, such as router maintenance.



Note Pseudowire redundancy is provided only for point-to-point Virtual Private Wire Service (VPWS) pseudowires.

Flow Aware Transport Pseudowire (FAT PW)

Flow Aware Transport Pseudowires (FAT PW) are used to load-balance traffic in the core when equal cost multipaths (ECMP) are used. The flow, in this context, refers to a sequence of packets that have the same source and destination pair. The packets are transported from a source provider edge (PE) to a destination PE.

The following figure shows a FAT PW with two flows distributing over ECMPs and bundle links.

Figure 9: FAT PW with two flows distributing over ECMPs and Bundle-Links

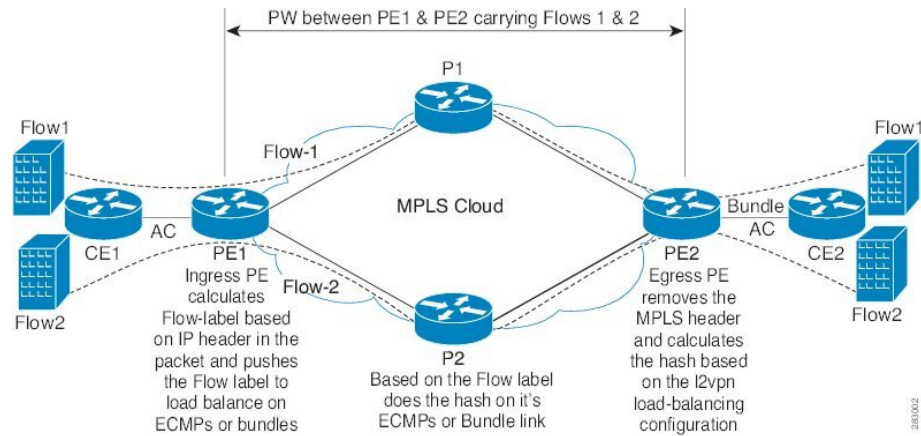

The MPLS labels add an additional label to the stack, called the flow label, which contains the flow information of a virtual circuit (VC). A flow label is a unique identifier that distinguishes a flow within the PW, and is derived from the IP payload of a packet. The flow label contains the end of label stack (EOS) bit set and inserted after the VC label and before the control word (if any). The ingress PE calculates and forwards the flow label. The FAT PW configuration enables the flow label. The egress PE discards the flow label such that no decisions are taken based on that label.

All core routers perform load balancing based on the flow-label in the FAT PW. Therefore, it is possible to distribute flows over ECMPs and link bundles.

You cannot send MPLS OAM ping traffic over a FAT PW, since there is no flow label support for MPLS OAM.

Any Transport over MPLS

Any Transport over MPLS (AToM) transports Layer 2 packets over a Multiprotocol Label Switching (MPLS) backbone. This enables service providers to connect customer sites with existing Layer 2 networks by using a single, integrated, packet-based network infrastructure. Using this feature, service providers can deliver Layer 2 connections over an MPLS backbone, instead of using separate networks.

AToM encapsulates Layer 2 frames at the ingress PE router, and sends them to a corresponding PE router at the other end of a pseudowire, which is a connection between the two PE routers. The egress PE removes the encapsulation and sends out the Layer 2 frame.

The successful transmission of the Layer 2 frames between PE routers is due to the configuration of the PE routers. You set up a connection, called a *pseudowire*, between the routers. You specify this information on each PE router:

- The type of Layer 2 data that will be transported across the pseudowire, such as Ethernet, or ATM
- The IP address of the loopback interface of the peer PE router, which enables the PE routers to communicate.
- A unique combination of peer PE IP address and VC ID that identifies the pseudowire.

These topics describe the AToM feature:

- [Control Word Processing](#)

Control Word Processing

The control word contains forward explicit congestion notification (FECN), backward explicit congestion notification (BECN) and DE bits in case of frame relay connection.

Control word is mandatory for:

- ATM AAL5

L2VPN Nonstop Routing

The L2VPN Nonstop Routing (NSR) feature avoids label distribution path (LDP) sessions from flapping on events such as process failures (crash) and route processor failover (RP FO). NSR on process failure (crash) is supported by performing RP FO, if you have enabled NSR using NSR process failure switchover.

NSR enables the router (where failure has occurred) to maintain the control plane states without a graceful restart (GR). NSR, by definition, does not require any protocol extension and typically uses Stateful Switch Over (SSO) to maintain its control plane states.



Note NSR is enabled by default for L2VPN on Cisco IOS XR 64 bit operating system. You cannot configure the `nsr` command under L2VPN configuration submenu.

How to Implement Point to Point Layer 2 Services

This section describes the tasks required to implement Point to Point Layer 2 Services:

Configuring an Interface or Connection for Point to Point Layer 2 Services

Perform this task to configure an interface or a connection for Point to Point Layer 2 Services.

SUMMARY STEPS

1. **configure**
2. **interface** *type interface-path-id*
3. **l2transport**
4. **exit**
5. **interface** *type interface-path-id.subinterface* **l2transport**
6. **encapsulation dot1q** *vlan-id*
7. Use the **commit** or **end** command.

DETAILED STEPS

Step 1 **configure**

Example:

```
RP/0/RP0/CPU0:router# configure
```

Enters the Global Configuration mode.

Step 2 **interface** *type interface-path-id*

Example:

```
RP/0/RP0/CPU0:router(config)# interface TenGigE 0/0/0/0
```

Enters interface configuration mode and configures an interface.

Step 3 **l2transport**

Example:

```
RP/0/RP0/CPU0:router(config-if)# l2transport
```

Enables L2 transport on the selected interface.

Step 4 **exit**

Example:

```
RP/0/RP0/CPU0:router(config-if-l2)# exit
```

Exits the current configuration mode.

Step 5 **interface** *type interface-path-id.subinterface* **l2transport**

Example:

```
RP/0/RP0/CPU0:router(config)# interface TenGigE 0/0/0/0.1 l2transport
```

Enters subinterface configuration mode and configures the subinterface as a layer 2 interface.

Step 6 **encapsulation dot1q** *vlan-id*

Example:

```
RP/0/RP0/CPU0:router(config-if)# encapsulation dot1q vln1
```

Assigns native VLAN ID to an interface trunking 802.1Q VLAN traffic.

Step 7 Use the **commit** or **end** command.

commit - Saves the configuration changes and remains within the configuration session.

end - Prompts user to take one of these actions:

- **Yes** - Saves configuration changes and exits the configuration session.
- **No** - Exits the configuration session without committing the configuration changes.
- **Cancel** - Remains in the configuration mode, without committing the configuration changes.

Configuring Static Point-to-Point Cross-Connects



-
- Note** Consider this information about cross-connects when you configure static point-to-point cross-connects:
- An cross-connect is uniquely identified with the pair; the cross-connect name must be unique within a group.
 - A segment (an attachment circuit or pseudowire) is unique and can belong only to a single cross-connect.
 - A static VC local label is globally unique and can be used in one pseudowire only.
 - No more than 16,000 cross-connects can be configured per router.
-



-
- Note** Static pseudowire connections do not use LDP for signaling.
-

Perform this task to configure static point-to-point cross-connects.

SUMMARY STEPS

1. **configure**
2. **l2vpn**
3. **xconnect group** *group-name*
4. **p2p** *xconnect-name*
5. **interface** *type interface-path-id*
6. **neighbor** *ip-address pw-id pseudowire-id*
7. **mpls static label local** { *value* } **remote** { *value* }
8. Use the **commit** or **end** command.
9. *show l2vpn xconnect group group name*

DETAILED STEPS

Step 1 **configure**

Example:

```
RP/0/RP0/CPU0:router# configure
```

Enters the Global Configuration mode.

Step 2 **l2vpn**

Example:

```
RP/0/RP0/CPU0:router(config)# l2vpn
```

Enters L2VPN configuration mode.

Step 3 **xconnect group** *group-name*

Example:

```
RP/0/RP0/CPU0:router(config-l2vpn)# xconnect group vlan_grp_1
```

Enters the name of the cross-connect group.

Step 4 **p2p** *xconnect-name*

Example:

```
RP/0/RP0/CPU0:router(config-l2vpn-xc)# p2p vlan1
```

Enters a name for the point-to-point cross-connect.

Step 5 **interface** *type interface-path-id*

Example:

```
RP/0/RP0/CPU0:router(config-l2vpn-xc-p2p)# interface TenGigE 0/0/0/0.1
```

Specifies the interface type and instance.

Step 6 **neighbor** *ip-address pw-id pseudowire-id*

Example:

```
RP/0/RP0/CPU0:router(config-l2vpn-xc-p2p)# neighbor 2.2.2.2 pw-id 2000
```

Configures the pseudowire segment for the cross-connect.

Optionally, you can disable the control word or set the transport-type to Ethernet or VLAN.

Step 7 **mpls static label local** { *value* } **remote** { *value* }

Example:

```
RP/0/RP0/CPU0:router(config-l2vpn-xc-p2p-pw)# mpls static label local 699 remote 890
```

Configures local and remote label ID values.

Step 8 Use the **commit** or **end** command.

commit - Saves the configuration changes and remains within the configuration session.

end - Prompts user to take one of these actions:

- **Yes** - Saves configuration changes and exits the configuration session.
- **No** - Exits the configuration session without committing the configuration changes.
- **Cancel** - Remains in the configuration mode, without committing the configuration changes.

Step 9 **show l2vpn xconnect group** *group name*

Example:

```
RP/0/RP0/CPU0:show l2vpn xconnect group vlan_grp_1
```

Displays the name of the Point-to-Point cross-connect group you created.

Configuring Dynamic Point-to-Point Cross-Connects

Perform this task to configure dynamic point-to-point cross-connects.



Note For dynamic cross-connects, LDP must be up and running.

SUMMARY STEPS

1. **configure**
2. **l2vpn**
3. **xconnect group** *group-name*
4. **p2p** *xconnect-name*
5. **interworking ipv4**
6. **interface** *type interface-path-id*
7. **neighbor** *ip-address pw-id pseudowire-id*
8. Use the **commit** or **end** command.

DETAILED STEPS

Step 1 **configure**

Example:

```
RP/0/RP0/CPU0:router# configure
```

Enters the Global Configuration mode.

Step 2 **l2vpn**

Example:

```
RP/0/RP0/CPU0:router(config)# l2vpn
```

Enters L2VPN configuration mode.

Step 3 **xconnect group** *group-name*

Example:

```
RP/0/RP0/CPU0:router(config-l2vpn)# xconnect group grp_1
```

Enters the name of the cross-connect group.

Step 4 `p2p` *xconnect-name***Example:**

```
RP/0/RP0/CPU0:router(config-l2vpn-xc)# p2p vlan1
```

Enters a name for the point-to-point cross-connect.

Step 5 `interworking` **ipv4****Example:**

```
RP/0/RP0/CPU0:router(config-l2vpn-xc)# interworking ipv4
```

Configure the interworking for IPv4.

Step 6 `interface` *type interface-path-id***Example:**

```
RP/0/RP0/CPU0:router(config-l2vpn-xc-p2p)# interface GigabitEthernet0/0/0/0.1
```

Specifies the interface type ID. The choices are:

- GigabitEthernet: GigabitEthernet/IEEE 802.3 interfaces.
- TenGigE: TenGigabitEthernet/IEEE 802.3 interfaces.
- CEM: Circuit Emulation interface

Step 7 `neighbor` *ip-address* **pw-id** *pseudowire-id***Example:**

```
RP/0/RP0/CPU0:router(config-l2vpn-xc-p2p)# neighbor 2.2.2.2 pw-id 2000
```

Configures the pseudowire segment for the cross-connect.

Optionally, you can disable the control word or set the transport-type to Ethernet or VLAN.

Step 8 Use the **commit** or **end** command.

commit - Saves the configuration changes and remains within the configuration session.

end - Prompts user to take one of these actions:

- **Yes** - Saves configuration changes and exits the configuration session.
- **No** - Exits the configuration session without committing the configuration changes.
- **Cancel** - Remains in the configuration mode, without committing the configuration changes.

Configuring Inter-AS

The Inter-AS configuration procedure is identical to the L2VPN cross-connect configuration tasks (see “[Configuring Static Point-to-Point Cross-Connects](#)” section and “[Configuring Dynamic Point-to-Point Cross-Connects](#)” section) except that the remote PE IP address used by the cross-connect configuration is now reachable through iBGP peering.



Note You must be knowledgeable about IBGP, EBGP, and ASBR terminology and configurations to complete this configuration.

Configuring L2VPN Quality of Service

This section describes how to configure L2VPN quality of service (QoS) in port mode and mode, VLAN mode, Frame Relay and ATM sub-interfaces.

Restrictions

The **l2transport** command cannot be used with any IP address, L3, or CDP configuration.

Configuring an L2VPN Quality of Service Policy in Port Mode

This procedure describes how to configure an L2VPN QoS policy in port mode.



Note In port mode, the interface name format does not include a subinterface number; for example, GigabitEthernet0/1/0/1.

SUMMARY STEPS

1. **configure**
2. **interface** *type interface-path-id* **l2transport**
3. **service-policy** [**input** | **output**] [*policy-map-name*]
4. Use the **commit** or **end** command.

DETAILED STEPS

Step 1 **configure**

Example:

```
RP/0/RP0/CPU0:router# configure
```

Enters the configuration mode.

Step 2 **interface** *type interface-path-id* **l2transport**

Example:

```
RP/0/RP0/CPU0:router(config)# interface GigabitEthernet 0/0/0/0
```

Configures an interface or connection for L2 switching and specifies the interface attachment circuit.

Step 3 **service-policy** [**input** | **output**] [*policy-map-name*]

Example:

```
RP/0/RP0/CPU0:router(config-if)# service-policy input servpoll
```

Attaches a QoS policy to an input or output interface to be used as the service policy for that interface.

Step 4 Use the **commit** or **end** command.

commit - Saves the configuration changes and remains within the configuration session.

end - Prompts user to take one of these actions:

- **Yes** - Saves configuration changes and exits the configuration session.
- **No** - Exits the configuration session without committing the configuration changes.
- **Cancel** - Remains in the configuration mode, without committing the configuration changes.

Configuring an L2VPN Quality of Service Policy in VLAN Mode

This procedure describes how to configure a L2VPN QoS policy in VLAN mode.



Note In VLAN mode, the interface name must include a subinterface. for example: GigabitEthernet0/1/0/1.1 and the l2transport command must follow the interface type on the same CLI line (for example: “interface GigabitEthernet 0/0/0/0.1 l2transport”).

SUMMARY STEPS

1. **configure**
2. **interface** *type interface-path-id.subinterface* **l2transport**
3. **service-policy** [**input** | **output**] [*policy-map-name*]
4. Use the **commit** or **end** command.

DETAILED STEPS

Step 1 **configure**

Example:

```
RP/0/RP0/CPU0:router# configure
```

Enters the Global Configuration mode.

Step 2 **interface** *type interface-path-id.subinterface* **l2transport**

Example:

```
RP/0/RP0/CPU0:router(config)# interface GigabitEthernet0/0/0/0.1 l2transport
```

Configures an interface or connection for L2 switching.

Note In VLAN Mode, you must enter the **l2transport** keyword on the same line as the interface.

Step 3 `service-policy [input | output] [policy-map-name]`**Example:**

```
RP/0/RP0/CPU0:router(config-if)# service-policy input servpoll
```

Attaches a QoS policy to an input or output interface to be used as the service policy for that interface.

Step 4 Use the **commit** or **end** command.

commit - Saves the configuration changes and remains within the configuration session.

end - Prompts user to take one of these actions:

- **Yes** - Saves configuration changes and exits the configuration session.
- **No** - Exits the configuration session without committing the configuration changes.
- **Cancel** - Remains in the configuration mode, without committing the configuration changes.

Configuring Preferred Tunnel Path

This procedure describes how to configure a preferred tunnel path.

SUMMARY STEPS

1. **configure**
2. **l2vpn**
3. **pw-class {name}**
4. **encapsulation mpls**
5. **preferred-path {interface} {tunnel-ip value | tunnel-te value | tunnel-tp value} [fallback disable]**
6. Use the **commit** or **end** command.

DETAILED STEPS

Step 1 `configure`**Example:**

```
RP/0/RP0/CPU0:router# configure
```

Enters the configuration mode.

Step 2 `l2vpn`

Example:

```
RP/0/RP0/CPU0:router(config)# l2vpn
```

Enters L2VPN configuration mode.

Step 3 **pw-class** *{name}***Example:**

```
RP/0/RP0/CPU0:router(config-l2vpn)# pw-class path1
```

Configures the pseudowire class name.

Step 4 **encapsulation mpls****Example:**

```
RP/0/RP0/CPU0:router(config-l2vpn-pwc)# encapsulation mpls
```

Configures the pseudowire encapsulation to MPLS.

Step 5 **preferred-path** *{interface}* *{tunnel-ip value | tunnel-te value | tunnel-tp value}* [**fallback disable**]**Example:**

```
RP/0/RP0/CPU0:router(config-l2vpn-pwc-encap-mpls)# preferred-path interface tunnel-te 11 fallback
disable
```

Configures preferred path tunnel settings. If the fallback disable configuration is used and once the TE/ tunnel is configured as the preferred path goes down, the corresponding pseudowire can also go down.

Step 6 Use the **commit** or **end** command.

commit - Saves the configuration changes and remains within the configuration session.

end - Prompts user to take one of these actions:

- **Yes** - Saves configuration changes and exits the configuration session.
- **No** - Exits the configuration session without committing the configuration changes.
- **Cancel** - Remains in the configuration mode, without committing the configuration changes.

Enabling Load Balancing with ECMP and FAT PW

Perform this task to enable load balancing with ECMP and FAT PW.

SUMMARY STEPS

1. **configure**
2. **l2vpn**
3. **pw-class** *{name}*
4. **encapsulation mpls**
5. **load-balancing flow-label both**
6. Use the **commit** or **end** command.

DETAILED STEPS

Step 1 **configure**

Example:

```
RP/0/RP0/CPU0:router# configure
```

Enters the Global Configuration mode.

Step 2 **l2vpn**

Example:

```
RP/0/RP0/CPU0:router(config)# l2vpn
```

Enters the L2VPN configuration mode.

Step 3 **pw-class {name}**

Example:

```
RP/0/RP0/CPU0:router(config-l2vpn)# pw-class FAT_PW
```

Configures the pseudowire class name.

Step 4 **encapsulation mpls**

Example:

```
RP/0/RP0/CPU0:router(config-l2vpn-pwc)# encapsulation mpls
```

Configures the pseudowire encapsulation to MPLS.

Step 5 **load-balancing flow-label both**

Example:

```
RP/0/RP0/CPU0:router(config-l2vpn-pwc-encap-
mpls)# load-balancing flow-label both
```

Enables load-balancing on ECMPs. Also, enables the imposition and disposition of flow labels for the pseudowire.

Step 6 Use the **commit** or **end** command.

commit - Saves the configuration changes and remains within the configuration session.

end - Prompts user to take one of these actions:

- **Yes** - Saves configuration changes and exits the configuration session.
 - **No** - Exits the configuration session without committing the configuration changes.
 - **Cancel** - Remains in the configuration mode, without committing the configuration changes.
-

Configuring L2VPN Nonstop Routing

Perform this task to configure L2VPN Nonstop Routing.

SUMMARY STEPS

1. **configure**

2. **l2vpn**
3. **nsr**
4. **logging nsr**
5. Use the **commit** or **end** command.

DETAILED STEPS

Step 1 **configure**

Example:

```
RP/0/RP0/CPU0:router# configure
```

Enters Global Configuration mode.

Step 2 **l2vpn**

Example:

```
RP/0/RP0/CPU0:router (config)# l2vpn
```

Enters the Global Configuration mode.

Step 3 **nsr**

Example:

```
RP/0/RP0/CPU0:router (config-l2vpn)# nsr
```

Enables L2VPN nonstop routing.

Step 4 **logging nsr**

Example:

```
RP/0/RP0/CPU0:router (config-l2vpn)# logging nsr
```

Enables logging of NSR events.

Step 5 Use the **commit** or **end** command.

commit - Saves the configuration changes and remains within the configuration session.

end - Prompts user to take one of these actions:

- **Yes** - Saves configuration changes and exits the configuration session.
 - **No** - Exits the configuration session without committing the configuration changes.
 - **Cancel** - Remains in the configuration mode, without committing the configuration changes.
-

Configure MPLS LDP Nonstop Routing

Perform this task to enable Label Distribution Protocol (LDP) Nonstop Routing (NSR) for synchronizing label information between active and standby LDPs. From Release 6.1.1 onwards, with the introduction of stateful LDP feature, you must explicitly configure LDP NSR to synchronize label information between active and standby LDPs.

SUMMARY STEPS

1. **configure**
2. **mpls ldp**
3. **nsr**
4. Use the **commit** or **end** command.

DETAILED STEPS

Step 1 **configure**

Example:

```
RP/0/RP0/CPU0:router# configure
```

Enters Global Configuration mode.

Step 2 **mpls ldp**

Example:

```
RP/0/RP0/CPU0:router(config)# mpls ldp
```

Enters MPLS LDP configuration mode.

Step 3 **nsr**

Example:

```
RP/0/RP0/CPU0:router(config-ldp)# nsr
```

Enables LDP nonstop routing.

Step 4 Use the **commit** or **end** command.

commit - Saves the configuration changes and remains within the configuration session.

end - Prompts user to take one of these actions:

- **Yes** - Saves configuration changes and exits the configuration session.
 - **No** - Exits the configuration session without committing the configuration changes.
 - **Cancel** - Remains in the configuration mode, without committing the configuration changes.
-

Configuration Examples for Point to Point Layer 2 Services

In the following example, two traffic classes are created and their match criteria are defined. For the first traffic class called class1, ACL 101 is used as the match criterion. For the second traffic class called class2, ACL 102 is used as the match criterion. Packets are checked against the contents of these ACLs to determine if they belong to the class.

This section includes the following configuration examples:

L2VPN Interface Configuration: Example

This example shows how to configure an L2VPN interface:

```
configure
interface TenGigE 0/0/0/0.1 l2transport
encapsulation dot1q 1
end
```

Point-to-Point Cross-connect Configuration: Examples

This section includes configuration examples for both static and dynamic p2p cross-connects.

Static Configuration

This example shows how to configure a static point-to-point cross-connect:

```
configure
l2vpn
xconnect group vlan_grp_1
p2p vlan1
interworking ipv4
interface TenGigE 0/0/0/0.1
neighbor 2.2.2.2 pw-id 2000
mpls static label local 699 remote 890
commit
```

Dynamic Configuration

This example shows how to configure a dynamic point-to-point cross-connect:

```
configure
l2vpn
xconnect group vlan_grp_1
p2p vlan1
interface TenGigE 0/0/0/0.1
neighbor 2.2.1.1 pw-id 1
commit
```

Inter-AS: Example

This example shows how to set up an AC to AC cross-connect from AC1 to AC2:

```
router-id Loopback0
```

```

interface Loopback0
ipv4 address 127.0.0.1 255.255.255.0
!
interface GigabitEthernet0/1/0/0.1 l2transport encapsulation dot1q 1
!
interface GigabitEthernet0/0/0/3
ipv4 address 127.0.0.1 255.255.255.0
keepalive disable
!
interface GigabitEthernet0/0/0/4
ipv4 address 127.0.0.1 255.255.255.0
keepalive disable
!
router ospf 100
log adjacency changes detail
area 0
interface Loopback0
!
interface GigabitEthernet0/0/0/3
!
interface GigabitEthernet0/0/0/4
!
!
!
router bgp 100
address-family ipv4 unicast
allocate-label all
!
neighbor 40.0.0.5
remote-as 100
update-source Loopback0
address-family ipv4 unicast
!
address-family ipv4 labeled-unicast
!
!
!
l2vpn
xconnect group xc1
p2p ac2ac1
interface GigabitEthernet0/1/0/0.1
neighbor 20.0.0.5 pw-id 101
!
p2p ac2ac2
interface GigabitEthernet0/1/0/0.2
neighbor 20.0.0.5 pw-id 102
!
p2p ac2ac3
interface GigabitEthernet0/1/0/0.3
neighbor 20.0.0.5 pw-id 103
!
p2p ac2ac4
interface GigabitEthernet0/1/0/0.4
neighbor 20.0.0.5 pw-id 104
!
p2p ac2ac5
interface GigabitEthernet0/1/0/0.5
neighbor 20.0.0.5 pw-id 105
!
p2p ac2ac6
interface GigabitEthernet0/1/0/0.6
neighbor 20.0.0.5 pw-id 106
!
p2p ac2ac7

```

```

interface GigabitEthernet0/1/0/0.7
neighbor 20.0.0.5 pw-id 107
!
p2p ac2ac8
interface GigabitEthernet0/1/0/0.8
neighbor 20.0.0.5 pw-id 108
!
p2p ac2ac9
interface GigabitEthernet0/1/0/0.9
neighbor 20.0.0.5 pw-id 109
!
p2p ac2ac10
interface GigabitEthernet0/1/0/0.10
neighbor 20.0.0.5 pw-id 110
!
!
!
mpls ldp
router-id Loopback0
log
neighbor
!
interface GigabitEthernet0/0/0/3
!
interface GigabitEthernet0/0/0/4
!
!
end

```

L2VPN Quality of Service: Example

This example shows how to attach a service-policy to an L2 interface in port mode:

```

configure
 interface GigabitEthernet 0/0/0/0
 l2transport

commit

```

Preferred Path: Example

This example shows how to configure preferred tunnel path:

```

configure
l2vpn
pw-class path1
encapsulation mpls
preferred-path interface tunnel-ip value fallback disable

```

Enabling Load Balancing with FAT PW: Example

This sample configuration shows how to enable load balancing with FAT PW for VPWS.

```

l2vpn
pw-class class1
 encapsulation mpls
 load-balancing flow-label transmit
!

```

```

!
pw-class class2
  encapsulation mpls
  load-balancing flow-label both
!

xconnect group group1
  p2p p1
  interface TenGigE 0/0/0/0.1
  neighbor 10.0.0.1 pw-id 1
  pw-class class1
  !
!
!

```

This sample configuration shows how to enable load balancing with FAT PW for VPLS.



Note For VPLS, the configuration at the bridge-domain level is applied to all PWs (access and VFI PWs). Pseudowire classes are defined to override the configuration for manual PWs.

```

l2vpn
bridge group group1
  bridge-domain domain1
  neighbor 10.0.0.1 pw-id 1
  pw-class class1
  !
  vfi vfi-manual
  neighbor 172.16.0.1 pw-id 2
  pw-class class2
  !
!
!
bridge-domain domain2
  vfi vfi2-auto-bgp
  autodiscovery bgp
  signaling-protocol bgp
  load-balancing flow-label both static
  !
!
!
bridge-domain domain3
  vfi vfi2-auto-ldp
  autodiscovery bgp
  signaling-protocol ldp
  load-balancing flow-label both static
  !
!
!
!
!

```

AToM Cross Connect Configuration: Example

This section includes configuration examples for all supported AToM Cross Connects.

```

l2vpn
pseudowire-class ipiw
  encapsulation mpls

```

```

!
xconnect group port
  p2p port1
    interface GigabitEthernet0/0/0/2
      neighbor 11.11.11.11 pw-id 300 pw-class ipiw
!
!
xconnect group vlan
  p2p vlan1
    interface GigabitEthernet0/0/0/3.1
      neighbor 11.11.11.11 pw-id 400 pw-class ipiw
!
!
xconnect group frame-relay
  p2p framel
    interface POS0/2/0/1.20
      neighbor 11.11.11.11 pw-id 600 pw-class ipiw
!
!
xconnect group atm
  p2p atm1
    interface ATM0/3/0/1.200
      neighbor 11.11.11.11 pw-id 700 pw-class ipiw
!
  p2p atm2
    interface ATM0/3/0/1.300
      neighbor 11.11.11.11 pw-id 800 pw-class ipiw

```

Configuring L2VPN over GRE Tunnels: Example

The following example shows how to configure L2VPN over GRE tunnels:

```

interface tunnel-ip101
  ipv4 address 150.10.1.204 255.255.255.0
  ipv6 address 150:10:1::204/64
  tunnel mode gre ipv4
  tunnel source Loopback1
  tunnel destination 100.1.1.202

router ospf 1
  router-id 100.0.1.204
  cost 1
  router-id Loopback0
  area 1
    interface Loopback0
    !
    interface tunnel-ip101

mpls ldp
  router-id 100.0.1.204
  interface tunnel-ip101

l2vpn
  xconnect group pe2
  p2p 2001
    interface GigabitEthernet0/2/0/0.2001
    neighbor 100.0.1.202 pw-id 2001

```

Configuring L2VPN Nonstop Routing: Example

This example shows how to configure L2VPN Nonstop Routing.

```
config
l2vpn
nsr
logging nsr
```



CHAPTER 3

Implementing MPLS VPNs over IP Tunnels

The MPLS VPNs over IP Tunnels feature lets you deploy Layer 3 Virtual Private Network (L3VPN) services, over an IP core network, using L2TPv3 multipoint tunneling instead of MPLS. This allows L2TPv3 tunnels to be configured as multipoint tunnels to transport IP VPN services across the core IP network.

Feature History for Implementing MPLS VPNs over IP Tunnels on Cisco IOS XR

Release	Modification
Release 3.5.0	This feature was introduced.
Release 3.8.0	The Multiple Tunnel Source Address feature was supported.

- [Prerequisites for Configuring MPLS VPNs over IP Tunnels, on page 33](#)
- [Restrictions for Configuring MPLS VPNs over IP Tunnels, on page 34](#)
- [Information About MPLS VPNs over IP Tunnels, on page 34](#)
- [How to Configure MPLS VPNs over IP Tunnels, on page 38](#)
- [Configuration Examples for MPLS VPNs over IP Tunnels, on page 50](#)

Prerequisites for Configuring MPLS VPNs over IP Tunnels

The following prerequisites are required to implement MPLS VPNs over IP Tunnels:

- To perform these configuration tasks, your Cisco IOS XR software system administrator must assign you to a user group associated with a task group that includes the corresponding command task IDs. All command task IDs are listed in individual command references and in the *Cisco IOS XR Task ID Reference Guide*.

If you need assistance with your task group assignment, contact your system administrator.

- You must be in a user group associated with a task group that includes the proper task IDs for
 - BGP commands
 - MPLS commands (generally)
 - MPLS Layer 3 VPN commands

Restrictions for Configuring MPLS VPNs over IP Tunnels

The following restriction applies when you configure MPLS VPNs over IP tunnels:

- MPLS forwarding cannot be enabled on a provider edge (PE) router.

Information About MPLS VPNs over IP Tunnels

To implement MPLS VPNs over IP Tunnels, you must understand the following concepts:

Overview: MPLS VPNs over IP Tunnels

Traditionally, VPN services are deployed over IP core networks using MPLS, or L2TPv3 tunnels using point-to-point links. However, an L2TPv3 multipoint tunnel network allows L3VPN services to be carried through the core without the configuration of MPLS.

L2TPv3 multipoint tunneling supports multiple tunnel endpoints, which creates a full-mesh topology that requires only one tunnel to be configured on each PE router. This permits VPN traffic to be carried from enterprise networks across cooperating service provider core networks to remote sites.

The following figure below illustrates the topology used for the configuration steps.

Figure 10: Basic MPLS VPN over IP Topology

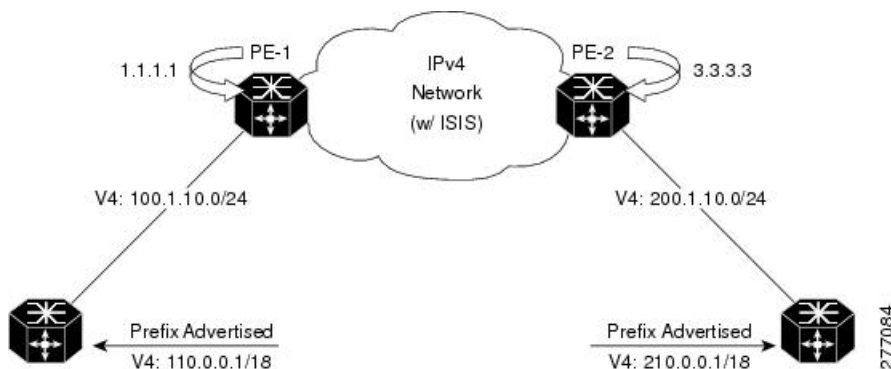

Advertising Tunnel Type and Tunnel Capabilities Between PE Routers—BGP

Border Gateway Protocol (BGP) is used to advertise the tunnel endpoints and the subaddress family identifier (SAFI) specific attributes (which contains the tunnel type, and tunnel capabilities). This feature introduces the tunnel SAFI and the BGP SAFI-Specific Attribute (SSA) attribute.

These attributes allow BGP to distribute tunnel encapsulation information between PE routers. VPNv4 traffic is routed through these tunnels. The next hop, advertised in BGP VPNv4 updates, determines which tunnel to use for routing tunnel traffic.

SAFI

The tunnel SAFI defines the tunnel endpoint and carries the endpoint IPv4 address and next hop. It is identified by the SAFI number 64.

BGP SSA

The BGP SSA carries the BGP preference and BGP flags. It also carries the tunnel cookie, tunnel cookie length, and session ID. It is identified by attribute number 19.

PE Routers and Address Space

One multipoint L2TPv3 tunnel must be configured on each PE router. To create the VPN, you must configure a unique Virtual Routing and Forwarding (VRF) instance. The tunnel that transports the VPN traffic across the core network resides in its own address space.

Packet Validation Mechanism

The MPLS VPNs over IP Tunnels feature provides a simple mechanism to validate received packets from appropriate peers. The multipoint L2TPv3 tunnel header is automatically configured with a 64-bit cookie and L2TPv3 session ID. This packet validation mechanism protects the VPN from illegitimate traffic sources. The cookie and session ID are not user-configurable, but they are visible in the packet as it is routed between the two tunnel endpoints. Note that this packet validation mechanism does not protect the VPN from hackers who are able to monitor legitimate traffic between PE routers.

Quality of Service Using the Modular QoS CLI

To configure the bandwidth on the encapsulation and decapsulation interfaces, use the modular QoS CLI (MQC).



Note This task is optional.

Use the MQC to configure the IP precedence or Differentiated Services Code Point (DSCP) value set in the IP carrier header during packet encapsulation. To set these values, enter a standalone **set** command or a **police** command using the keyword **tunnel**. In the input policy on the encapsulation interface, you can set the precedence or DSCP value in the IP payload header by using MQC commands without the keyword **tunnel**.



Note You must attach a QoS policy to the physical interface—*not* to the tunnel interface.

If Modified Deficit Round Robin (MDRR)/Weighted Random Early Detection (WRED) is configured for the encapsulation interface in the input direction, the final value of the precedence or DSCP field in the IP carrier header is used to determine the precedence class for which the MDRR/WRED policy is applied. On the decapsulation interface in the input direction, you can configure a QoS policy based on the precedence or DSCP value in the IP carrier header of the received packet. In this case, an MQC policy with a class to match on precedence or DSCP value will match the precedence or DSCP value in the received IP carrier header.

Similarly, the precedence class for which the MDRR/WRED policy is applied on the decapsulation input direction is also determined by precedence or DSCP value in the IP carrier header.

BGP Multipath Load Sharing for MPLS VPNs over IP Tunnels

BGP Multipath Load Sharing for EBGP and IBGP lets you configure multipath load balancing with both external BGP and internal BGP paths in BGP networks that are configured to use MPLS VPNs. (When faced with multiple routes to the same destination, BGP chooses the best route for routing traffic toward the destination so that no individual router is overburdened.)

BGP Multipath Load Sharing is useful for multihomed autonomous systems and PE routers that import both EBGP and IBGP paths from multihomed and stub networks.

Inter-AS over IP Tunnels

The L3VPN Inter-AS feature provides a method of interconnecting VPNs between different VPN service providers. Inter-AS supports connecting different VPN service providers to provide native IP L3VPN services. For more information about Inter-AS, see [Implementing MPLS VPNs over IP Tunnels](#).



Note The Cisco CRS-1 router supports only the Inter-AS option A.

Multiple Tunnel Source Address

Currently, L2TPv3 tunnel encapsulation transports the VPN traffic across the IP core network between PEs with a /32 loopback addresses of PEs, and ingress PE uses a single /32 loopback address as the source IP address of tunnel encapsulation. This results in an imbalance on the load. In order to achieve load balance in the core, the ingress PE sends the VPN traffic with the source IP address of a L2TPv3 tunnel header taken from the pool for a /28 IP address instead of a single /32 address. This is called the Multiple Tunnel Source Address.

To support the /28 IP address, a keyword **source-pool** is used as an optional configuration command for the tunnel template. This keyword is located in the source address configuration. The source address is published to remote PEs through the BGP's tunnel SAFI messages.

Once the optional source-pool address is configured, it is sent to the forwarding information base (FIB). FIB uses a load balancing algorithm to get one address from the pool, and uses that address to call the tunnel infra DLL API to construct the tunnel encapsulation string.

The Multiple Tunnel Source Address infrastructure uses two primary models:

Tunnel MA

The Tunnel MA tunnel is used for the tunnel-template configuration and communicating with the BGP. It supports the /28 IP address by performing these basic tasks:

- Verifies and applies the /28 address pool configuration
- Extends the tunnel information to include the new address pool
- Sends the address pool information to Tunnel EA through the data path control (DPC)



Note Sending the address pool information to BGP is not mandatory.

Tunnel EA

Tunnel EA sends the address pool information to FIB and also supports the /28 IP address by performing these basic tasks:

- Processes the address pool information in the DPC from tunnel MA
- Saves the address pool information in the tunnel IDB in EA
- Sends the source address pool information to FIB

6PE/6VPE over L2TPv3

The 6PE/6VPE over L2TPv3 feature supports native IPv6 (6PE) and IPv6 VPN services (6VPE) (described in RFC 2547) over L2TPv3 tunnels across an IPv4 core network. The 6PE/6VPE over L2TPv3 feature is supported for label, IPv6 VPN (6VPE) and 6PE traffic.

When an IP VPN service is deployed, VPN traffic is typically transported across the core network between service provider edge routers (PEs) using MPLS label switched paths (LSPs).

Native IP Layer 3 VPNs (based on generalized RFC 2547) eliminate the need for MPLS between the participating core routers by implementing L2TPv3 tunnel encapsulation over IP. Such tunnels may be used to transport VPN traffic between participating edge routers.

The 6VPE over L2TPv3 feature uses IPv6 VRFs, and the multi-protocol BGP advertises VPNv6 service advertisement framework (SAF) or advertisement framework (AF) between PE routers. The customer edge IPv6 VPN packets are transported across the provider's IP backbone. Additionally, the customer edge IPv6 VPN packets employ the same encapsulation (L2TPv3 + IPv4 delivery header) as is currently supported in L2TPv3 for IPv4 VPN services.

The following figure depicts the key elements that are used to extend multi-protocol BGP to distribute VPNv6 prefixes along with the appropriate next hop (IPv4 address) and tunnel attributes. The data encapsulations remain the same except that the payload is now an IPv6 packet.

For more information on configuring L2TPv3, see the [Implementing Layer 2 Tunnel Protocol Version 3](#) module.

Figure 11: IPv4/6VPE over L2TPv3

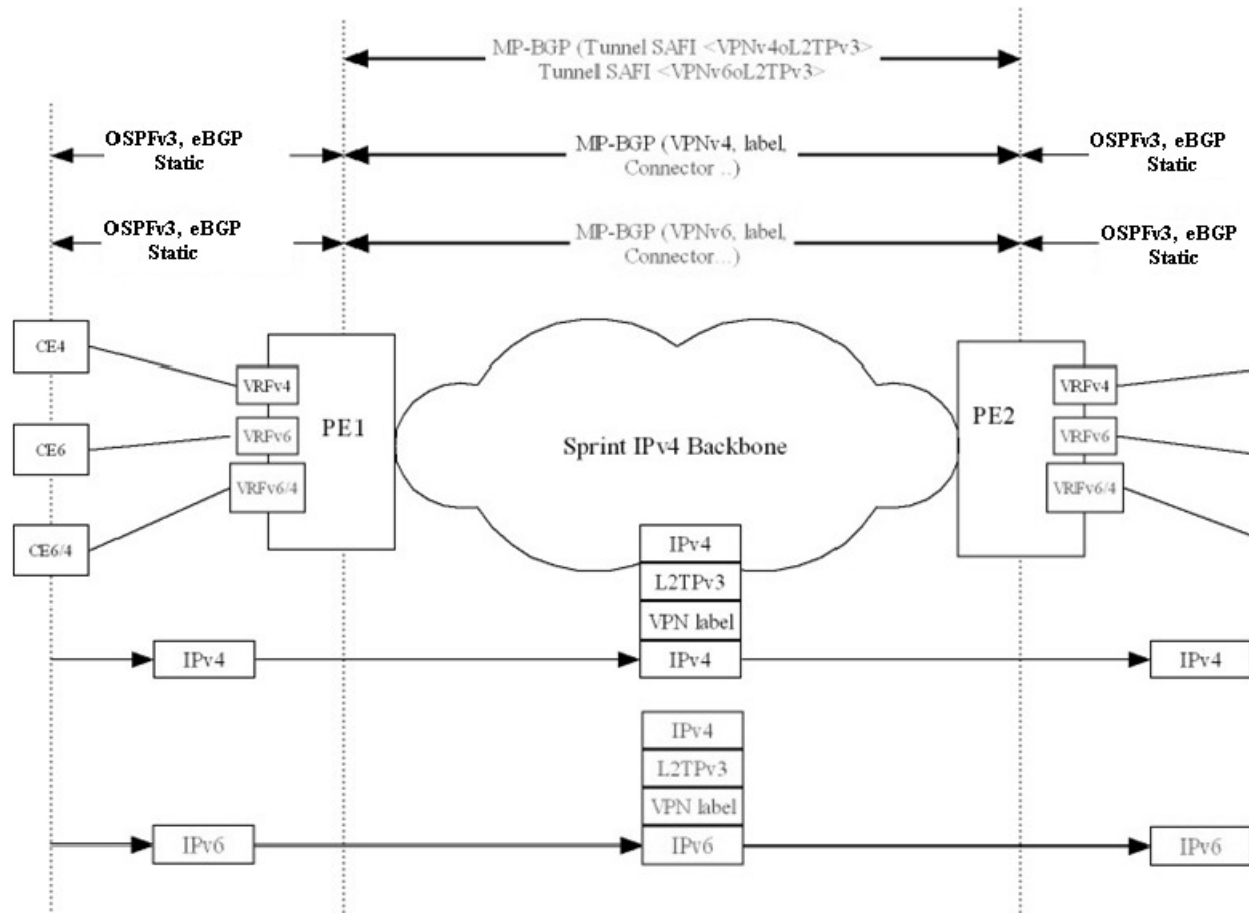

How to Configure MPLS VPNs over IP Tunnels

The following procedures are required to configure MPLS VPN over IP:



Note All procedures occur on the local PE (PE1). Corresponding procedures must be configured on the remote PE (PE2).

Configuring the Global VRF Definition

Perform this task to configure the global VRF definition.

SUMMARY STEPS

1. **configure**
2. **vrf vrf-name**

3. **address-family ipv4 unicast**
4. **import route-target** [0-65535.0-65535:0-65535 | *as-number:nn* | *ip-address:nn*]
5. **export route-target** [0-65535.0-65535:0-65535 | *as-number:nn* | *ip-address:nn*]
6. **exit**
7. **address-family ipv6 unicast**
8. **import route-target** [0-65535.0-65535:0-65535 | *as-number:nn* | *ip-address:nn*]
9. **export route-target** [0-65535.0-65535:0-65535 | *as-number:nn* | *ip-address:nn*]
10. Use the **commit** or **end** command.

DETAILED STEPS

Step 1 **configure**

Example:

```
RP/0/RP0/CPU0:router# configure
```

Enters the Global Configuration mode.

Step 2 **vrf vrf-name**

Example:

```
RP/0/RP0/CPU0:router(config)# vrf vrf-name
```

Specifies a name assigned to a VRF.

Step 3 **address-family ipv4 unicast**

Example:

```
RP/0/RP0/CPU0:router(config-vrf)# address-family ipv4 unicast
```

Specifies an IPv4 address-family address.

Step 4 **import route-target** [0-65535.0-65535:0-65535 | *as-number:nn* | *ip-address:nn*]

Example:

```
RP/0/RP0/CPU0:router(config-vrf-af)# import route-target 500:99
```

Configures a VPN routing and forwarding (VRF) import route-target extended community.

Step 5 **export route-target** [0-65535.0-65535:0-65535 | *as-number:nn* | *ip-address:nn*]

Example:

```
RP/0/RP0/CPU0:router(config-vrf-af)# export route-target 700:44
```

Configures a VPN routing and forwarding (VRF) export route-target extended community.

Step 6 **exit**

Example:

```
RP/0/RP0/CPU0:router(config-vrf-af)# exit
```

Exits interface configuration mode.

Step 7 **address-family ipv6 unicast**

Example:

```
RP/0/RP0/CPU0:router(config-vrf)# address-family ipv4 unicast
```

Specifies an IPv4 address-family address.

Step 8 **import route-target [0-65535.0-65535:0-65535 | as-number:nn | ip-address:nn]**

Example:

```
RP/0/RP0/CPU0:router(config-vrf-af)# import route-target 500:99
```

Configures a VPN routing and forwarding (VRF) import route-target extended community.

Step 9 **export route-target [0-65535.0-65535:0-65535 | as-number:nn | ip-address:nn]**

Example:

```
RP/0/RP0/CPU0:router(config-vrf-af)# import route-target 700:88
```

Configures a VPN routing and forwarding (VRF) export route-target extended community.

Step 10 Use the **commit** or **end** command.

commit - Saves the configuration changes and remains within the configuration session.

end - Prompts user to take one of these actions:

- **Yes** - Saves configuration changes and exits the configuration session.
- **No** - Exits the configuration session without committing the configuration changes.
- **Cancel** - Remains in the configuration mode, without committing the configuration changes.

Configuring a Route-Policy Definition

Perform this task to configure a route-policy definition for CE-PE EBGp.

SUMMARY STEPS

1. **configure**
2. **route-policy name pass**
3. **end policy**

DETAILED STEPS

Step 1 **configure**

Example:

```
RP/0/RP0/CPU0:router# configure
```

Enters the Global Configuration mode.

Step 2 `route-policy name pass`**Example:**

```
RP/0/RP0/CPU0:router(config)# route-policy ottawa_admin pass
```

Defines and passes a route policy.

Step 3 `end policy`**Example:**

```
RP/0/RP0/CPU0:router(config-rpl)# end policy
```

End of route-policy definition.

Configuring a Static Route

Perform this task to add more than 4K static routes (Global/VRF).

SUMMARY STEPS

1. `configure`
2. `router static`
3. `maximum path ipv4 1-140000`
4. `maximum path ipv6 1-140000`
5. Use the `commit` or `end` command.

DETAILED STEPS

Step 1 `configure`**Example:**

```
RP/0/RP0/CPU0:router# configure
```

Enters the Global Configuration mode.

Step 2 `router static`**Example:**

```
RP/0/RP0/CPU0:router(config)# router static
```

Enters static route configuration subcommands.

Step 3 `maximum path ipv4 1-140000`**Example:**

```
RP/0/RP0/CPU0:router(config-static)# maximum path ipv4 1-140000
```

Enters the maximum number of static ipv4 paths that can be configured.

Step 4 **maximum path ipv6** *1-140000*

Example:

```
RP/0/0/CPU0:router(config-static)# maximum path ipv6 1-140000
```

Step 5 Use the **commit** or **end** command.

commit - Saves the configuration changes and remains within the configuration session.

end - Prompts user to take one of these actions:

- **Yes** - Saves configuration changes and exits the configuration session.
- **No** - Exits the configuration session without committing the configuration changes.
- **Cancel** - Remains in the configuration mode, without committing the configuration changes.

Configuring an IPv4 Loopback Interface

The following task describes how to configure an IPv4 Loopback interface.

SUMMARY STEPS

1. **configure**
2. **interface** *type interface-path-id*
3. **ipv4 address** *ipv4-address*
4. Use the **commit** or **end** command.

DETAILED STEPS

Step 1 **configure**

Example:

```
RP/0/RP0/CPU0:router# configure
```

Enters Global Configuration mode.

Step 2 **interface** *type interface-path-id*

Example:

```
RP/0/RP0/CPU0:router(config)# interface Loopback0
```

Enters interface configuration mode and enables a Loopback interface.

Step 3 **ipv4 address** *ipv4-address*

Example:

```
RP/0/RP0/CPU0:router(config-if)# ipv4 address 10.0.0.1 255.0.0.0
```

Enters an IPv4 address and mask for the associated IP subnet. The network mask can be specified in either of two ways:

- The network mask can be a four-part dotted decimal address. For example, 255.0.0.0 indicates that each bit equal to 1 means that the corresponding address bit belongs to the network address.
- The network mask can be indicated as a slash (/) and number. For example, /8 indicates that the first 8 bits of the mask are ones, and the corresponding bits of the address are the network address.

Step 4 Use the **commit** or **end** command.

commit - Saves the configuration changes and remains within the configuration session.

end - Prompts user to take one of these actions:

- **Yes** - Saves configuration changes and exits the configuration session.
- **No** - Exits the configuration session without committing the configuration changes.
- **Cancel** - Remains in the configuration mode, without committing the configuration changes.

Configuring a CFI VRF Interface

Perform this task to associate a VPN routing and forwarding (VRF) instance with an interface or a subinterface on the PE routers.

SUMMARY STEPS

1. **configure**
2. **interface** *type interface-path-id*
3. **vrf** *vrf-name*
4. **ipv4 address** *ipv4-address*
5. **ipv6 address** *ipv6-address*
6. **dot1q native vlan** *vlan-id*
7. Use the **commit** or **end** command.

DETAILED STEPS

Step 1 **configure**

Example:

```
RP/0/RP0/CPU0:router# configure
```

Enters the Global Configuration mode.

Step 2 **interface** *type interface-path-id*

Example:

```
RP/0/RP0/CPU0:router(config)# interface GigabitEthernet0/0/0/1.1
```

Enters interface configuration mode and enables a GigabitEthernet interface.

Step 3 **vrf** *vrf-name*

Example:

```
RP/0/RP0/CPU0:router(config-if)# vrf v1
```

Specifies a VRF name.

Step 4 **ipv4 address** *ipv4-address*

Example:

```
RP/0/RP0/CPU0:router(config-if)# ipv4 address 100.1.10.2 255.255.255.0
```

Enters an IPv4 address and mask for the associated IP subnet. The network mask can be specified in either of two ways:

- The network mask can be a four-part dotted decimal address. For example, 255.0.0.0 indicates that each bit equal to 1 means that the corresponding address bit belongs to the network address.
- The network mask can be indicated as a slash (/) and number. For example, /8 indicates that the first 8 bits of the mask are ones, and the corresponding bits of the address are network address.

Step 5 **ipv6 address** *ipv6-address*

Example:

```
RP/0/0/CPU0:router(config-if)# ipv6 100::1:10:2/64
```

Enters an IPv6 address.

This argument must be in the form documented in RFC 2373, where the address is specified in hexadecimal using 16-bit values between colons, as follows:

- IPv6 name or address: Hostname or X:X::X%zone
- IPv6 prefix: X:X::X%zone/<0-128>

Step 6 **dot1q native vlan** *vlan-id*

Example:

```
RP/0/RP0/CPU0:router(config-if)# dot1q native vlan 665
```

(Optional) Enters the trunk interface ID. Range is from 1 to 4094 inclusive (0 and 4095 are reserved).

Step 7 Use the **commit** or **end** command.

commit - Saves the configuration changes and remains within the configuration session.

end - Prompts user to take one of these actions:

- **Yes** - Saves configuration changes and exits the configuration session.
- **No** - Exits the configuration session without committing the configuration changes.
- **Cancel** - Remains in the configuration mode, without committing the configuration changes.

Configuring the Core Network

Configuring the core network includes the following tasks:

Configuring Inter-AS over IP Tunnels

These tasks describe how to configure Inter-AS over IP tunnels:

Configuring the ASBRs to Exchange VPN-IPv4 Addresses for IP Tunnels

Perform this task to configure an external Border Gateway Protocol (eBGP) autonomous system boundary router (ASBR) to exchange VPN-IPv4 routes with another autonomous system.

SUMMARY STEPS

1. **configure**
2. **router bgp** *autonomous-system-number*
3. **address-family** { **ipv4 tunnel** }
4. **address-family** { **vpn4 unicast** }
5. **retain route-target** { **all** | **route-policy** *route-policy-name* }
6. **neighbor** *ip-address*
7. **remote-as** *autonomous-system-number*
8. **address-family** { **vpn4 unicast** }
9. **route-policy** *route-policy-name* { **in** }
10. **route-policy** *route-policy-name* { **out** }
11. **neighbor** *ip-address*
12. **remote-as** *autonomous-system-number*
13. **update-source** *type interface-path-id*
14. **address-family** { **ipv4 tunnel** }
15. **address-family** { **vpn4 unicast** }
16. Use the **commit** or **end** command.

DETAILED STEPS

Step 1 **configure**

Example:

```
RP/0/RP0/CPU0:router# configure
```

Enters the Global Configuration mode.

Step 2 **router bgp** *autonomous-system-number*

Example:

```
RP/0/RP0/CPU0:router(config)# router bgp 120
RP/0/RP0/CPU0:router(config-bgp)#
```

Enters Border Gateway Protocol (BGP) configuration mode allowing you to configure the BGP routing process.

Step 3 **address-family** { **ipv4 tunnel** }

Example:

```
RP/0/RP0/CPU0:router(config-bgp)# address-family ipv4 tunnel
RP/0/RP0/CPU0:router(config-bgp-af)#
```

Configures IPv4 tunnel address family.

Step 4 **address-family { vpnv4 unicast }**

Example:

```
RP/0/RP0/CPU0:router(config-bgp-af)# address-family vpnv4 unicast
```

Configures VPNv4 address family.

Step 5 **retain route-target { all | route-policy route-policy-name }**

Example:

```
RP/0/RP0/CPU0:router(config-bgp-af)# retain route-target route-policy policy1
```

Retrieves VPNv4 table from PE routers.

The **retain route-target** command is required on an Inter-AS option B ASBR. You can use this command with either **all** or **route-policy** keyword

Step 6 **neighbor ip-address**

Example:

```
RP/0/RP0/CPU0:router(config-bgp-af)# neighbor 172.168.40.24
RP/0/RP0/CPU0:router(config-bgp-nbr)#
```

Places the router in neighbor configuration mode for BGP routing and configures the neighbor IP address 172.168.40.24 as an ASBR eBGP peer.

Step 7 **remote-as autonomous-system-number**

Example:

```
RP/0/RP0/CPU0:router(config-bgp-nbr)# remote-as 2002
```

Creates a neighbor and assigns it a remote autonomous system number.

Step 8 **address-family { vpnv4 unicast }**

Example:

```
RP/0/RP0/CPU0:router(config-bgp-nbr)# address-family vpnv4 unicast
RP/0/RP0/CPU0:router(config-bgp-nbr-af)#
```

Configures VPNv4 address family.

Step 9 **route-policy route-policy-name { in }**

Example:

```
RP/0/RP0/CPU0:router(config-bgp-nbr-af)# route-policy pass-all in
```

Applies a routing policy to updates that are received from a BGP neighbor.

- Use the *route-policy-name* argument to define the name of the of route policy. The example shows that the route policy name is defined as pass-all.

- Use the **in** keyword to define the policy for inbound routes.

Step 10 `route-policy route-policy-name { out }`

Example:

```
RP/0/RP0/CPU0:router(config-bgp-nbr-af)# route-policy pass-all out
```

Applies a routing policy to updates that are sent from a BGP neighbor.

- Use the `route-policy-name` argument to define the name of the route policy. The example shows that the route policy name is defined as `pass-all`.
- Use the **out** keyword to define the policy for outbound routes.

Step 11 `neighbor ip-address`

Example:

```
RP/0/RP0/CPU0:router(config-bgp-nbr-af)# neighbor 175.40.25.2
RP/0/RP0/CPU0:router(config-bgp-nbr)#
```

Places the router in neighbor configuration mode for BGP routing and configures the neighbor IP address 175.40.25.2 as an VPNv4 iBGP peer.

Step 12 `remote-as autonomous-system-number`

Example:

```
RP/0/RP0/CPU0:router(config-bgp-nbr)# remote-as 2002
```

Creates a neighbor and assigns it a remote autonomous system number.

Step 13 `update-source type interface-path-id`

Example:

```
RP/0/RP0/CPU0:router(config-bgp-nbr)# update-source loopback0
```

Allows BGP sessions to use the primary IP address from a particular interface as the local address.

Step 14 `address-family { ipv4 tunnel }`

Example:

```
RP/0/RP0/CPU0:router(config-bgp-nbr)# address-family ipv4 tunnel
RP/0/RP0/CPU0:router(config-bgp-nbr-af)#
```

Configures IPv4 tunnel address family.

Step 15 `address-family { vpnv4 unicast }`

Example:

```
RP/0/RP0/CPU0:router(config-bgp-nbr-af)# address-family vpnv4 unicast
```

Configures VPNv4 address family.

Step 16 Use the **commit** or **end** command.

commit - Saves the configuration changes and remains within the configuration session.

end - Prompts user to take one of these actions:

- **Yes** - Saves configuration changes and exits the configuration session.
- **No** - Exits the configuration session without committing the configuration changes.
- **Cancel** - Remains in the configuration mode, without committing the configuration changes.

Configuring the Backbone Carrier Core for IP Tunnels

Configuring the backbone carrier core requires setting up connectivity and routing functions for the CSC core and the CSC-PE routers. To do so, you must complete the following high-level tasks:

- Verify IP connectivity in the CSC core.
- Configure IP tunnels in the core.
- Configure VRFs .
- Configure multiprotocol BGP for VPN connectivity in the backbone carrier.

Verifying MPLS VPN over IP

To verify the configuration of end-end (PE-PE) MPLS VPN over IP provisioning, use the following **show** commands:

- **show cef recursive-nexthop**
- **show bgp ipv4 tunnel**
- **show bgp vpnv4 unicast summary**
- **show bgp vrf v1 ipv4 unicast summary**
- **show bgp vrf v1 ipv4 unicast *prefix***
- **show cef vrf v1 ipv4 *prefix***
- **show cef ipv6 recursive-nexthop**
- **show bgp vpnv6 unicast summary**
- **show bgp vrf v1 ipv6 unicast summary**
- **show bgp vrf v1 ipv6 unicast *prefix***
- **show cef vrf v1 ipv6 *prefix***

Configuring Source Pool Address for MPLS VPNs over IP Tunnels

Perform this task to configure the Multiple Tunnel Source Address.

SUMMARY STEPS

1. **configure**
2. **tunnel-template *name***
3. **mtu [*mtu-value*]**
4. **ttl [*ttl-value*]**
5. **tos [*tos-value*]**
6. **source *loopback type interface-path-id***
7. **source-pool *A.B.C.D/prefix***
8. **encapsulation *l2tp***

9. Use the **commit** or **end** command.

DETAILED STEPS

Step 1 **configure**

Example:

```
RP/0/RP0/CPU0:router# configure
```

Enters the Global Configuration mode.

Step 2 **tunnel-template** *name*

Example:

```
RP/0/RP0/CPU0:router(config)# tunnel-template test  
RP/0/RP0/CPU0:router(config-tuntem)#
```

Configures the tunnel template for source address.

Step 3 **mtu** [*mtu-value*]

Example:

```
RP/0/RP0/CPU0:router(config-tuntem) mtu 600  
RP/0/RP0/CPU0:router(config-tuntem)#
```

Configures the maximum transmission unit for the tunnel.

Step 4 **ttl** [*ttl-value*]

Example:

```
RP/0/RP0/CPU0:router(config-tuntem) ttl 64  
RP/0/RP0/CPU0:router(config-tuntem)#
```

Configures the IP time to live (TTL).

Step 5 **tos** [*tos-value*]

Example:

```
RP/0/RP0/CPU0:router(config-tuntem) tos 7  
RP/0/RP0/CPU0:router(config-tuntem)#
```

Configures the tunnel header. By default, the TOS bits for the tunnel header are set to zero.

Step 6 **source** *loopback type interface-path-id*

Example:

```
RP/0/RP0/CPU0:router(config-tuntem) source loopback0
```

Configures the loopback interface.

Step 7 **source-pool** *A.B.C.D/prefix*

Example:

```
RP/0/RP0/CPU0:router(config-tuntem)# source-pool 10.10.10.0/28
```

Configures the source pool address.

Step 8 encapsulation l2tp**Example:**

```
RP/0/RP0/CPU0:router(config-tuntem)# encapsulation l2tp
RP/0/RP0/CPU0:router(config-config-tunencap-l2tp)#
```

Configures the Layer 2 Tunnel Protocol encapsulation.

Step 9 Use the **commit** or **end** command.

commit - Saves the configuration changes and remains within the configuration session.

end - Prompts user to take one of these actions:

- **Yes** - Saves configuration changes and exits the configuration session.
- **No** - Exits the configuration session without committing the configuration changes.
- **Cancel** - Remains in the configuration mode, without committing the configuration changes.

Configuration Examples for MPLS VPNs over IP Tunnels

This section provides the following examples:

Configuring an L2TPv3 Tunnel: Example

The following example shows how to configure an L2TPv3 tunnel:

```
tunnel-template t1
 encapsulation l2tp
 !
 source Loopback0
 !
```

Configuring the Global VRF Definition: Example

The following example shows how to configure an L2TPv3 tunnel:

```
vrf v1
 address-family ipv4 unicast
 import route-target
 1:1
 !
 export route-target
 1:1
 !
```

Configuring a Route-Policy Definition: Example

The following example shows how to configure a route-policy definition:

```
configure
  route-policy pass-all
  pass
end-policy
!
```

Configuring a Static Route: Example

The following example shows how to configure a static route:

```
configure
  router static
  maximum path ipv4 <1-140000>
  maximum path ipv6 <1-140000>
end-policy
!
```

Configuring an IPv4 Loopback Interface: Example

The following example shows how to configure an IPv4 Loopback Interface:

```
configure
  interface Loopback0
  ipv4 address 10.0.0.1 255.0.0.0
!
```

Configuring a CFI VRF Interface: Example

The following example shows how to configure an L2TPv3 tunnel:

```
configure
  interface GigabitEthernet0/0/0/1.1
  vrf v1
  ipv4 address 100.1.10.2 255.255.255.0

  encapsulation dot1q 101
!
```

Configuring Source Pool Address for MPLS VPNs over IP Tunnels: Example

```
configure
  tunnel-template test
  mtu 1500
  ttl 64
  ttl 7
  source Loopback0
  source-pool 10.10.10.0/28
  encapsulation l2tp
!
```



CHAPTER 4

Implementing Multipoint Layer 2 Services

This module provides the conceptual and configuration information for Multipoint Layer 2 Bridging Services, also called Virtual Private LAN Services (VPLS).



Note VPLS supports Layer 2 VPN technology and provides transparent multipoint Layer 2 connectivity for customers. This approach enables service providers to host a multitude of new services such as broadcast TV and Layer 2 VPNs.

For Point to Point Layer 2 Services, see *Implementing Point to Point Layer 2 Services* chapter.

For descriptions of the commands listed in this module, see the “Related Documents” section.

Feature History for Implementing Multipoint Layer 2 Services

Release	Modification
Release 3.8.0	This feature was introduced. Support for the bridging functionality feature (VPLS based) and pseudowire redundancy was added.
Release 3.9.0	The following features were added: <ul style="list-style-type: none">• Blocking unknown unicast flooding.• Disabling MAC flush.
Release 4.0	The following features were added: <ul style="list-style-type: none">• H-VPLS with MPLS Access pseudowire• H-VPLS with Ethernet Access• MAC Address withdrawal
Release 4.0.1	Support for the BGP Autodiscovery with LDP Signaling feature was added.
Release 4.1.0	Support for Pseudowire Headend feature was added.
Release 4.2.0	Support was added for: <ul style="list-style-type: none">• VPLS pseudowire on LDP over TE and Preferred TE path• VPLS with Traffic Engineering Fast Reroute (TE FRR)

Release	Modification
Release 4.2.1	Support was added for: <ul style="list-style-type: none"> • Pseudowire Headend on Cisco CRS-3 router • IPv6 packets over PWHE interfaces
Release 4.3.0	Support was added for the Pseudowire Grouping feature.

- [Prerequisites for Implementing Multipoint Layer 2 Services, on page 54](#)
- [Restrictions for Implementing Multipoint Layer 2 Services, on page 54](#)
- [Information About Implementing Multipoint Layer 2 Services, on page 55](#)
- [How to Implement Multipoint Layer 2 Services, on page 66](#)
- [Configuration Examples for Multipoint Layer 2 Services, on page 111](#)

Prerequisites for Implementing Multipoint Layer 2 Services

Before you configure Multipoint Layer 2 Services, ensure that the network is configured as follows:

- To perform these configuration tasks, your Cisco IOS XR software system administrator must assign you to a user group associated with a task group that includes the corresponding command task IDs. All command task IDs are listed in individual command references and in the *Cisco IOS XR Task ID Reference Guide*.

If you need assistance with your task group assignment, contact your system administrator.

- Configure IP routing in the core so that the provider edge (PE) routers can reach each other through IP.
- Configure MPLS and Label Distribution Protocol (LDP) in the core so that a label switched path (LSP) exists between the PE routers.
- Configure a loopback interface to originate and terminate Layer 2 traffic. Make sure that the PE routers can access the other router's loopback interface.



Note The loopback interface is not needed in all cases. For example, tunnel selection does not need a loopback interface when Multipoint Layer 2 Services are directly mapped to a TE tunnel.

Restrictions for Implementing Multipoint Layer 2 Services

The following restrictions are listed for implementing Multipoint Layer 2 Services:

- All attachment circuits in a bridge domain on an Engine 3 line card must be the same type (for example, port, dot1q, QinQ, or QinQ), value (VLAN ID), and EtherType (for example, 0x8100, 0x9100, or 0x9200).
The Cisco CRS-1 router supports multiple types of attachment circuits in a bridge domain.
- The line card requires ternary content addressable memory (TCAM) Carving configuration. The Cisco CRS-1 router however, does not require the TCAM Carving configuration.

- Virtual Forwarding Instance (VFI) names have to be unique, because a bridge domain can have only one VFI.
- A PW cannot belong to both a peer-to-peer (P2P) cross-connect group and a VPLS bridge-domain. This means that the neighboring IP address and the pseudowire ID have to be unique on the router, because the pseudowire ID is signaled to the remote provider edge.
- For the Engine 5 line card, version 1 of the Ethernet SPA does not support QinQ mode and QinAny mode.
- The CRS-X line card does not support bundle interfaces on multipoint layer 2 services.



Note For the Engine 5 line card, version 2 of the Ethernet SPA supports all VLAN modes, such as VLAN mode, QinQ mode, or QinAny mode. The Cisco CRS-1 router supports only the Ethernet port mode and the 802.1q VLAN mode.

Information About Implementing Multipoint Layer 2 Services

To implement Multipoint Layer 2 Services, you should understand these concepts:

Multipoint Layer 2 Services Overview

Multipoint Layer 2 Services enable geographically separated local-area network (LAN) segments to be interconnected as a single bridged domain over an MPLS network. The full functions of the traditional LAN such as MAC address learning, aging, and switching are emulated across all the remotely connected LAN segments that are part of a single bridged domain. A service provider can offer VPLS service to multiple customers over the MPLS network by defining different bridged domains for different customers. Packets from one bridged domain are never carried over or delivered to another bridged domain, thus ensuring the privacy of the LAN service.



Note Multipoint Layer 2 services are also called as Virtual Private LAN Services.

Multipoint Layer 2 Services transports Ethernet 802.3, VLAN 802.1q, and VLAN-in-VLAN (Q-in-Q) traffic across multiple sites that belong to the same Layer 2 broadcast domain. It offers simple Virtual LAN services that include flooding broadcast, multicast, and unknown unicast frames that are received on a bridge. The Multipoint Layer 2 Services solution requires a full mesh of pseudowires that are established among provider edge (PE) routers. The Multipoint Layer 2 Services implementation is based on Label Distribution Protocol (LDP)-based pseudowire signaling.

A VFI is a virtual bridge port that is capable of performing native bridging functions, such as forwarding, based on the destination MAC address, source MAC address learning and aging.

After provisioning attachment circuits, neighbor relationships across the MPLS network for this specific instance are established through a set of manual commands identifying the end PEs. When the neighbor association is complete, a full mesh of pseudowires is established among the network-facing provider edge devices, which is a gateway between the MPLS core and the customer domain.

The service provider network starts switching the packets within the bridged domain specific to the customer by looking at destination MAC addresses. All traffic with unknown, broadcast, and multicast destination MAC addresses is flooded to all the connected customer edge devices, which connect to the service provider network. The network-facing provider edge devices learn the source MAC addresses as the packets are flooded. The traffic is unicasted to the customer edge device for all the learned MAC addresses.

Multipoint Layer 2 Services require the provider edge device to be MPLS-capable. The Multipoint Layer 2 Services provides edge device holds all the VPLS forwarding MAC tables and Bridge Domain information. In addition, it is responsible for all flooding broadcast frames and multicast replications.

VPLS for an MPLS-based Provider Core

VPLS is a multipoint Layer 2 VPN technology that connects two or more customer devices using bridging techniques. The VPLS architecture allows for the end-to-end connection between the Provider Edge (PE) routers to provide Multipoint Ethernet Services.

VPLS requires the creation of a bridge domain (Layer 2 broadcast domain) on each of the PE routers. The access connections to the bridge domain on a PE router are called *attachment circuits* (AC).

The attachment circuits can be a set of physical ports, virtual ports, or both that are connected to the bridge at each PE device in the network.

The MPLS/IP provider core simulates a virtual bridge that connects the multiple attachment circuits on each of the PE devices together to form a single broadcast domain. A VFI is created on the PE router for each VPLS instance. The PE routers make packet-forwarding decisions by looking up the VFI of a particular VPLS instance. The VFI acts like a virtual bridge for a given VPLS instance. More than one attachment circuit belonging to a given VPLS are connected to the VFI. The PE router establishes emulated VCs to all the other PE routers in that VPLS instance and attaches these emulated VCs to the VFI. Packet forwarding decisions are based on the data structures maintained in the VFI.

Hierarchical VPLS

Hierarchical VPLS (H-VPLS) is an extension of basic VPLS that provides scaling and operational benefits. H-VPLS provides a solution to deliver Ethernet multipoint services over MPLS. H-VPLS partitions a network into several edge domains that are interconnected using an MPLS core. The use of Ethernet switches at the edge offers significant technical and economic advantages. H-VPLS also allows Ethernet point-to-point and multipoint Layer 2 VPN services, as well as Ethernet access to high-speed Internet and IP VPN services.

Two flavors of H-VPLS are:

- Ethernet access in the edge domain
- MPLS access in the edge domain

H-VPLS with Ethernet Access QinQ or QinAny

The following figure shows the Ethernet access for H-VPLS. The edge domain can be built using Ethernet switches and techniques such as QinQ. Using Ethernet as the edge technology simplifies the operation of the edge domain and reduces the cost of the edge devices.

Figure 12: Ethernet Access for H-VPLS

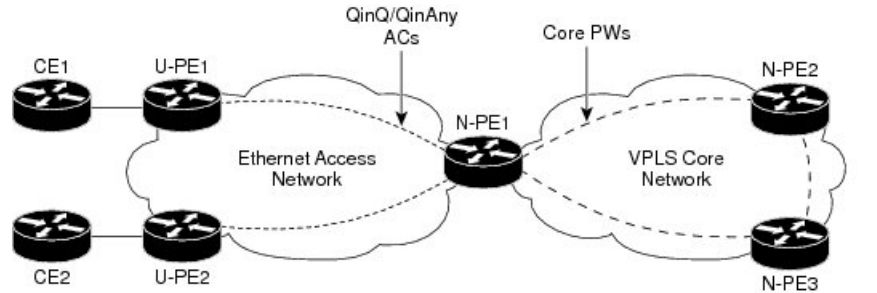

H-VPLS with PW-access

The following figure shows the pseudowire (PW) access for H-VPLS. The edge domain can be an MPLS access network. In this scenario, the U-PE device carries the customer traffic from attachment circuits (AC) over the point to point (p2p) pseudowires. The p2p pseudowires terminate in a bridge domain configured on the N-PE device.

Access PW is configured as a member directly under a bridge domain. A bridge-domain in N-PE1 can have multiple ACs (physical/VLAN Ethernet ports), multiple access PWs and one VFI (consisting of core PWs) as members, is depicted in the below figure.

Figure 13: PW access for H-VPLS

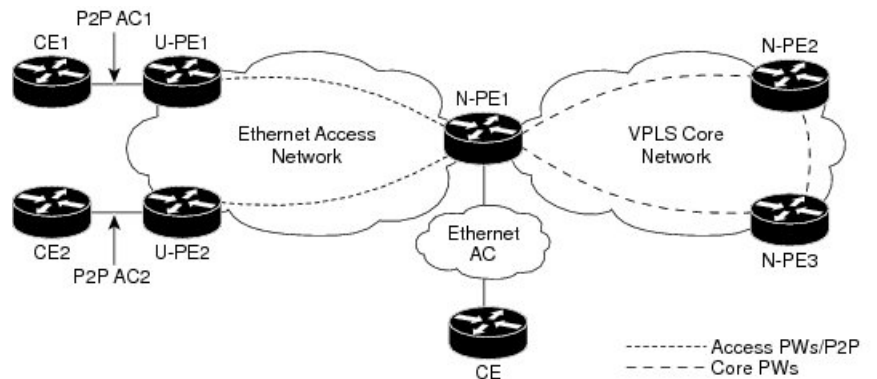

VPLS Discovery and Signaling

VPLS is a Layer 2 multipoint service and it emulates LAN service across a WAN service. VPLS enables service providers to interconnect several LAN segments over a packet-switched network and make it behave as one single LAN. Service provider can provide a native Ethernet access connection to customers using VPLS.

The VPLS control plane consists of two important components, autodiscovery and signaling:

- VPLS Autodiscovery eliminates the need to manually provision VPLS neighbors. VPLS Autodiscovery enables each VPLS PE router to discover the other provider edge (PE) routers that are part of the same VPLS domain.
- Once the PEs are discovered, pseudowires (PWs) are signaled and established across each pair of PE routers forming a full mesh of PWs across PE routers in a VPLS domain

Figure 14: VPLS Autodiscovery and Signaling

L2-VPN	Multipoint	
Discovery	BGP	
Signaling Protocol	LDP	BGP
Tunneling Protocol	MPLS	

240881

BGP-based VPLS Autodiscovery

An important aspect of VPN technologies, including VPLS, is the ability of network devices to automatically signal to other devices about an association with a particular VPN. Autodiscovery requires this information to be distributed to all members of a VPN. VPLS is a multipoint mechanism for which BGP is well suited.

BGP-based VPLS autodiscovery eliminates the need to manually provision VPLS neighbors. VPLS autodiscovery enables each VPLS PE router to discover the other provider edge (PE) routers that are part of the same VPLS domain. VPLS Autodiscovery also tracks when PE routers are added to or removed from the VPLS domain. When the discovery process is complete, each PE router has the information required to setup VPLS pseudowires (PWs).

Even when BGP autodiscovery is enabled, pseudowires can be manually configured for VPLS PE routers that are not participating in the autodiscovery process.

BGP Auto Discovery With BGP Signaling

The implementation of VPLS in a network requires the establishment of a full mesh of PWs between the provider edge (PE) routers. The PWs can be signaled using BGP signaling.

Figure 15: Discovery and Signaling Attributes

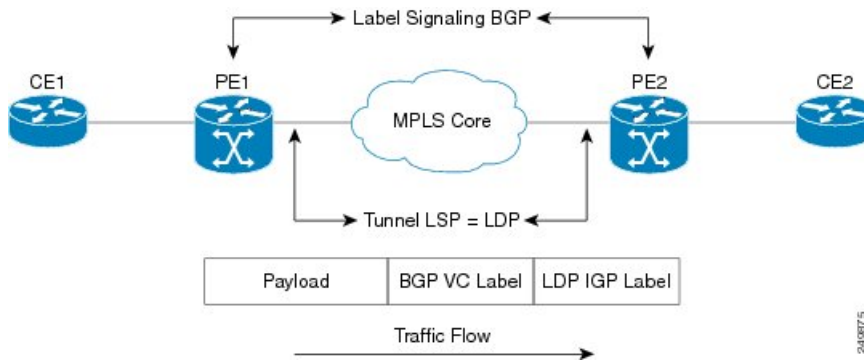

240875

The BGP signaling and autodiscovery scheme has the following components:

- A means for a PE to learn which remote PEs are members of a given VPLS. This process is known as autodiscovery.
- A means for a PE to learn the pseudowire label expected by a given remote PE for a given VPLS. This process is known as signaling.

The BGP Network Layer Reachability Information (NLRI) takes care of the above two components simultaneously. The NLRI generated by a given PE contains the necessary information required by any other PE. These components enable the automatic setting up of a full mesh of pseudowires for each VPLS without having to manually configure those pseudowires on each PE.

NLRI Format for VPLS with BGP AD and Signaling

The following figure shows the NLRI format for VPLS with BGP AD and Signaling

Figure 16: NLRI Format

Length (2 octets)
Route Distinguisher (8 octets)
VE ID (2 octets)
VE Block Offset (2 octets)
VE Block Size (2 octets)
Label Base (3 octets)

BGP Auto Discovery With LDP Signaling

Signaling of pseudowires requires exchange of information between two endpoints. Label Distribution Protocol (LDP) is better suited for point-to-point signaling. The signaling of pseudowires between provider edge devices, uses targeted LDP sessions to exchange label values and attributes and to configure the pseudowires.

Figure 17: Discovery and Signaling Attributes

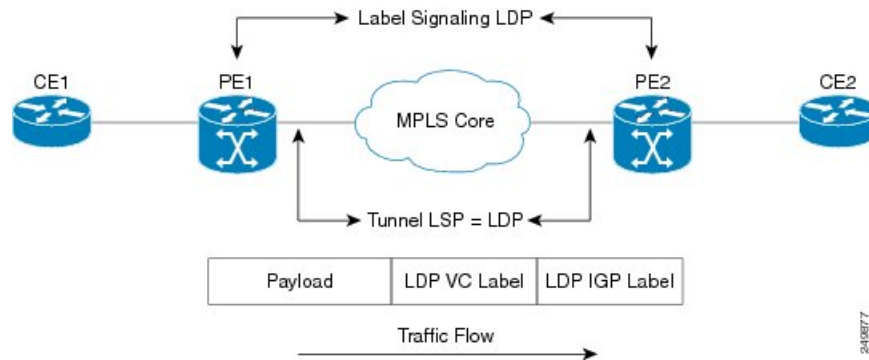

A PE router advertises an identifier through BGP for each VPLS. This identifier is unique within the VPLS instance and acts like a VPLS ID. The identifier enables the PE router receiving the BGP advertisement to identify the VPLS associated with the advertisement and import it to the correct VPLS instance. In this manner, for each VPLS, a PE router learns the other PE routers that are members of the VPLS.

The LDP protocol is used to configure a pseudowire to all the other PE routers. FEC 129 is used for the signaling. The information carried by FEC 129 includes the VPLS ID, the Target Attachment Individual Identifier (TAII) and the Source Attachment Individual Identifier (SAII).

The LDP advertisement also contains the inner label or VPLS label that is expected for the incoming traffic over the pseudowire. This enables the LDP peer to identify the VPLS instance with which the pseudowire is to be associated and the label value that it is expected to use when sending traffic on that pseudowire.

NLRI and Extended Communities

The following figure depicts Network Layer Reachability Information (NLRI) and extended communities (Ext Comms).

Figure 18: NLRI and Extended Communities

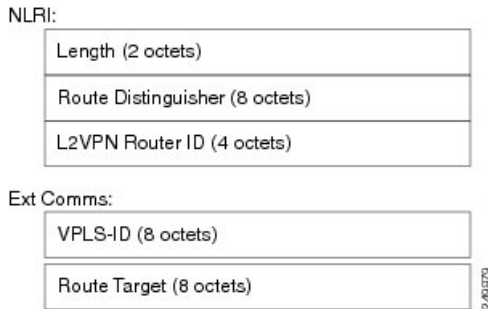

Interoperability Between Cisco IOS XR and Cisco IOS on VPLS LDP Signaling

The Cisco IOS Software encodes the NLRI length in the first byte in bits format in the BGP Update message. However, the Cisco IOS XR Software interprets the NLRI length in 2 bytes. Therefore, when the BGP neighbor with VPLS-VPWS address family is configured between the IOS and the IOS XR, NLRI mismatch can happen, leading to flapping between neighbors. To avoid this conflict, IOS supports **prefix-length-size 2** command that needs to be enabled for IOS to work with IOS XR. When the **prefix-length-size 2** command is configured in IOS, the NLRI length is encoded in bytes. This configuration is mandatory for IOS to work with IOS XR.

This is a sample IOS configuration with the **prefix-length-size 2** command:

```
router bgp 1
 address-family l2vpn vpls
  neighbor 5.5.5.2 activate
  neighbor 5.5.5.2 prefix-length-size 2 -----> NLRI length = 2 bytes
 exit-address-family
```

Bridge Domain

The native bridge domain refers to a Layer 2 broadcast domain consisting of a set of physical or virtual ports (including VFI). Data frames are switched within a bridge domain based on the destination MAC address. Multicast, broadcast, and unknown destination unicast frames are flooded within the bridge domain. In addition, the source MAC address learning is performed on all incoming frames on a bridge domain. A learned address is aged out. Incoming frames are mapped to a bridge domain, based on either the ingress port or a combination of both an ingress port and a MAC header field.

By default, split horizon is enabled on a bridge domain. In other words, any packets that are coming on either the attachment circuits or pseudowires are not returned on the same attachment circuits or pseudowires. In addition, the packets that are received on one pseudowire are not replicated on other pseudowires in the same VFI.

MAC Address-related Parameters

The MAC address table contains a list of the known MAC addresses and their forwarding information. In the current VPLS design, the MAC address table and its management are maintained on the route processor (RP) card.

These topics provide information about the MAC address-related parameters:

MAC Address Flooding

Ethernet services require that frames that are sent to broadcast addresses and to unknown destination addresses be flooded to all ports. To obtain flooding within VPLS broadcast models, all unknown unicast, broadcast, and multicast frames are flooded over the corresponding pseudowires and to all attachment circuits. Therefore, a PE must replicate packets across both attachment circuits and pseudowires.

MAC Address-based Forwarding

To forward a frame, a PE must associate a destination MAC address with a pseudowire or attachment circuit. This type of association is provided through a static configuration on each PE or through dynamic learning, which is flooded to all bridge ports.



Note In this case, split horizon forwarding applies; for example, frames that are coming in on an attachment circuit or pseudowire are not sent out of the same attachment circuit or pseudowire. The pseudowire frames, which are received on one pseudowire, are replicated on to other attachment circuits, VFI pseudowires and access pseudowires.

MAC Address Source-based Learning

When a frame arrives on a bridge port (for example, pseudowire or attachment circuit) and the source MAC address is unknown to the receiving PE router, the source MAC address is associated with the pseudowire or attachment circuit. Outbound frames to the MAC address are forwarded to the appropriate pseudowire or attachment circuit.

MAC address source-based learning uses the MAC address information that is learned in the hardware forwarding path. The updated MAC tables are propagated and programs the hardware for the router.



Note Static MAC move is not supported from one port, interface, or AC to another port, interface, or AC. For example, if a static MAC is configured on AC1 (port 1) and then, if you send a packet with the same MAC as source MAC on AC2 (port 2), then you can't attach this MAC to AC2 as a dynamic MAC. Therefore, do not send any packet with a MAC as any of the static MAC addresses configured.

The number of learned MAC addresses is limited through configurable per-port and per-bridge domain MAC address limits.

MAC Address Aging

A MAC address in the MAC table is considered valid only for the duration of the MAC address aging time. When the time expires, the relevant MAC entries are repopulated. When the MAC aging time is configured only under a bridge domain, all the pseudowires and attachment circuits in the bridge domain use that configured MAC aging time.

A bridge forwards, floods, or drops packets based on the bridge table. The bridge table maintains both static entries and dynamic entries. Static entries are entered by the network manager or by the bridge itself. Dynamic entries are entered by the bridge learning process. A dynamic entry is automatically removed after a specified length of time, known as *aging time*, from the time the entry was created or last updated.

If hosts on a bridged network are likely to move, decrease the aging-time to enable the bridge to adapt to the change quickly. If hosts do not transmit continuously, increase the aging time to record the dynamic entries for a longer time, thus reducing the possibility of flooding when the hosts transmit again.

MAC Address Limit

The MAC address limit is used to limit the number of learned MAC addresses.

When a limit is exceeded, the system is configured to perform these notifications:

- Syslog (default)
- Simple Network Management Protocol (SNMP) trap
- Syslog and SNMP trap
- None (no notification)

Restrictions

- You can configure up to a maximum of six different mac-limit values under a bridge domain for the following routers and line cards:
 - NCS-55A1-24H
 - NCS-55A1-48Q6H
 - NCS-55A1-36H
 - NCS-55A1-36H-SE
 - NCS-55A2-MOD-HD-S
 - NCS-55A2-MOD-S
 - NCS-5502
 - NCS-5502-SE
 - NCS55-36x100G-S
 - NC55-24H12F-SE
 - NCS55-36x100G-A-SS
- You can configure up to a maximum of 30 different mac-limit values under a bridge domain on routers that have the Cisco NC57 line cards installed.
- For NCS55xx routers and NCS57 line cards, the mac-limit value programmed in the hardware depends on the:
 - Static MAC address configured under the AC for a bridge domain.
 - BVI configured under a bridge domain.

Depending on the BVI or static MAC address configured, new mac-limit profiles are required. The following example shows the different bridge domains with default mac-limit with static MAC address and BVI.

Example 1

In this example, the bridge domain requires a default mac-limit profile. For instance, default mac-limit = X.

```
bridge-domain 1
 interface HundredGigE 0/0/0/10
```

Example 2

In this example, the bridge domain requires a new mac-limit profile with mac-limit = X+1 to accommodate the static BVI MAC address.

```
bridge-domain 2
 interface HundredGigE 0/0/0/11
   routed interface bvi
```

Example 3

In this example, the bridge domain requires a new mac-limit profile with mac-limit = X+2 to accommodate two static MAC addresses configured under the AC.

```
bridge-domain 3
 interface HundredGigE 0/0/0/12
   static-mac-address 0000.1111.2222
   static-mac-address 0000.2222.1111
```

MAC Address Withdrawal

For faster VPLS convergence, you can remove or unlearn the MAC addresses that are learned dynamically. The Label Distribution Protocol (LDP) Address Withdrawal message is sent with the list of MAC addresses, which need to be withdrawn to all other PEs that are participating in the corresponding VPLS service.

For the Cisco IOS XR VPLS implementation, a portion of the dynamically learned MAC addresses are cleared by using the MAC addresses aging mechanism by default. The MAC address withdrawal feature is added through the LDP Address Withdrawal message. To enable the MAC address withdrawal feature, use the **withdrawal** command in l2vpn bridge group bridge domain MAC configuration mode. To verify that the MAC address withdrawal is enabled, use the **show l2vpn bridge-domain** command with the **detail** keyword.



Note By default, the LDP MAC Withdrawal feature is enabled on Cisco IOS XR.

The LDP MAC Withdrawal feature is generated due to these events:

- Attachment circuit goes down. You can remove or add the attachment circuit through the CLI.
- MAC withdrawal messages are received over a VFI pseudowire. RFC 4762 specifies that both wildcards (by means of an empty Type, Length and Value [TLV]) and a specific MAC address withdrawal. Cisco IOS XR software supports only a wildcard MAC address withdrawal.

LSP Ping over VPWS and VPLS

For Cisco IOS XR software, the existing support for the Label Switched Path (LSP) ping and traceroute verification mechanisms for point-to-point pseudowires (signaled using LDP FEC128) is extended to cover the pseudowires that are associated with the VFI (VPLS). Currently, the support for the LSP ping and traceroute for LDP signalled FEC128 pseudowires is limited to manually configured VPLS pseudowires. In addition, Cisco IOS XR software supports LSP ping for point-to-point single-segment pseudowires that are signalled using LDP FEC129 AII-type 2 applicable to VPWS or signalled using LDP FEC129 AII-type 1 applicable

to VPLS. For information about Virtual Circuit Connection Verification (VCCV) support and the `ping mpls pseudowire` command, see the *MPLS Command Reference for the Cisco CRS Router*.

VPLS Scalability and Performance Targets

The Cisco CRS-1 router employs the ternary content addressable memory (TCAM) to meet the performance and scalable targets over VPLS.

The following table below describes the scalability and performance targets for the Cisco CRS-1 router.

Table 2: VPLS Scalability and Performance Targets

Performance	Scalability Target
Maximum bridge domains per Line Card	1024
Maximum bridge domains per system	1024
Maximum MACs per bridge domain	15999
Maximum MACs per Line Card	65536
Maximum MACs per system	65536
Maximum attachment circuits per bridge domain	4085
Maximum pseudowires per bridge domain	256
Maximum pseudowires per system	16340

Pseudowire Redundancy for P2P AToM Cross-Connects

Backup pseudowires (PW) are associated with the corresponding primary pseudowires. A backup PW is not programmed to forward data when inactive. It is activated only if a primary PW fails. This is known as *pseudowire redundancy*. The primary reason for backing up a PW is to reduce traffic loss when a primary PW fails. When the primary PW is active again, it resumes its activity.

A primary PW can be associated with only one backup PW. Similarly, a backup PW can be associated with only one primary PW.

It is recommended to enable pseudowire status time length value (TLV) for optimal switchover performance.



Note This feature is supported only for an AToM instance on the Cisco XR 12000 Series Router, and for an EoMPLS instance on the Cisco CRS-1 router.

Pseudowire Headend

Pseudowires (PWs) enable payloads to be transparently carried across IP/MPLS packet-switched networks (PSNs). PWs are regarded as simple and manageable lightweight tunnels for returning customer traffic into

core networks. Service providers are now extending PW connectivity into the access and aggregation regions of their networks.

Pseudowire Headend (PWHE) is a technology that allows termination of access pseudowires (PWs) into a Layer 3 (VRF or global) domain or into a Layer 2 domain. PWs provide an easy and scalable mechanism for tunneling customer traffic into a common IP/MPLS network infrastructure. PWHE allows customers to provision features such as QoS access lists (ACL), L3VPN on a per PWHE interface basis, on a service Provider Edge (PE) router.

Consider the following network topology as an example.

Figure 19: Pseudowire Network

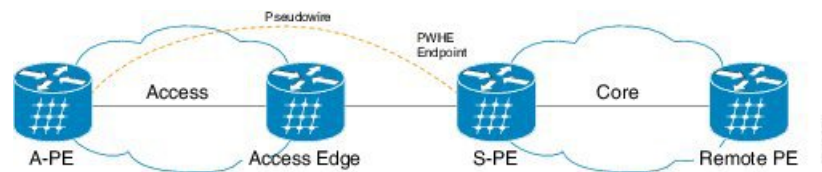

For PWHE x-connect configuration, interconnectivity between A-PE (Access Provider Edge) and S-PE is through BGP RFC3107 that distributes MPLS labels along with IP prefixes. The customer network can avoid using an IGP to provide connectivity to the S-PE device, which is outside the customer's autonomous system.

For all practical purposes, the PWHE interface is treated like any other existing L3 interface. PWs operate in one of the following modes:

- Bridged interworking (VC type 5 or VC type 4)
- IP interworking mode (VC type 11)

With VC type 4 and VC type 5, PWs carry customer Ethernet frames (tagged or untagged) with IP payload. Thus, an S-PE device must perform ARP resolution for customer IP addresses learned over the PWHE. With VC type 4 (VLAN tagged) and VC type 5 (Ethernet port/raw), PWHE acts as a broadcast interface. Whereas with VC type 11 (IP Interworking), PWHE acts as a point-to-point interface. Therefore there are two types of PWHE interface—PW-Ether (for VC type 4 and 5) and PW-IW (for VC type 11). These PWs can terminate into a VRF or the IP global table on S-PE.

PWHE Interfaces

The virtual circuit (VC) types supported for the PW are types 4, 5 and 11. The PWHE acts as broadcast interface with VC types 4 (VLAN tagged) and 5 (Ethernet port/Raw), whereas with VC type 11 (IP Interworking), the PWHE acts as a point-to-point interface.

Pseudowire Grouping

When pseudowires (PWs) are established, each PW is assigned a group ID that is common for all PWs created on the same physical port. When a physical port becomes non-functional or disabled, Automatic Protection Switching (APS) signals the peer router to get activated and L2VPN sends a single message to advertise the status change of all PWs that have the Group ID associated with the physical port. A single L2VPN signal thus avoids a lot of processing and loss in reactivity.



Note Pseudowire grouping is disabled by default.

How to Implement Multipoint Layer 2 Services

This section describes the tasks that are required to implement Multipoint Layer 2 Services:

Configuring a Bridge Domain

These topics describe how to configure a bridge domain:

Creating a Bridge Domain

Perform this task to create a bridge domain .

SUMMARY STEPS

1. **configure**
2. **l2vpn**
3. **bridge group** *bridge-group-name*
4. **bridge-domain** *bridge-domain-name*
5. Use the **commit** or **end** command.

DETAILED STEPS

Step 1 **configure**

Example:

```
RP/0/RP0/CPU0:router# configure
```

Enters the Global Configuration mode.

Step 2 **l2vpn**

Example:

```
RP/0/RP0/CPU0:router(config)# l2vpn
RP/0/RP0/CPU0:router(config-l2vpn)#
```

Enters L2VPN configuration mode.

Step 3 **bridge group** *bridge-group-name*

Example:

```
RP/0/RP0/CPU0:router(config-l2vpn)# bridge group cisco
RP/0/RP0/CPU0:router(config-l2vpn-bg)#
```

Creates a bridge group that can contain bridge domains, and then assigns network interfaces to the bridge domain.

Step 4 **bridge-domain** *bridge-domain-name*

Example:

```
RP/0/RP0/CPU0:router(config-l2vpn-bg)# bridge-domain abc
RP/0/RP0/CPU0:router(config-l2vpn-bg-bd)#
```

Establishes a bridge domain and enters L2VPN bridge group bridge domain configuration mode.

Step 5 Use the **commit** or **end** command.

commit - Saves the configuration changes and remains within the configuration session.

end - Prompts user to take one of these actions:

- **Yes** - Saves configuration changes and exits the configuration session.
- **No** - Exits the configuration session without committing the configuration changes.
- **Cancel** - Remains in the configuration mode, without committing the configuration changes.

Configuring a Pseudowire

Perform this task to configure a pseudowire under a bridge domain.

SUMMARY STEPS

1. **configure**
2. **l2vpn**
3. **bridge group** *bridge group name*
4. **bridge-domain** *bridge-domain name*
5. **vfi** { *vfi-name* }
6. **exit**
7. **neighbor** { *A.B.C.D* } { **pw-id** *value* }
8. Use the **commit** or **end** command.

DETAILED STEPS

Step 1 **configure**

Example:

```
RP/0/RP0/CPU0:router# configure
```

Enters the Global Configuration mode.

Step 2 **l2vpn**

Example:

```
RP/0/RP0/CPU0:router(config)# l2vpn
RP/0/RP0/CPU0:router(config-l2vpn)#
```

Enters L2VPN configuration mode.

Step 3 **bridge group** *bridge group name*

Example:

```
RP/0/RP0/CPU0:router(config-l2vpn)# bridge group csco
RP/0/RP0/CPU0:router(config-l2vpn-bg)#
```

Creates a bridge group so that it can contain bridge domains and then assigns network interfaces to the bridge domain.

Step 4 **bridge-domain** *bridge-domain name***Example:**

```
RP/0/RP0/CPU0:router(config-l2vpn-bg)# bridge-domain abc
RP/0/RP0/CPU0:router(config-l2vpn-bg-bd)#
```

Establishes a bridge domain and enters L2VPN bridge group bridge domain configuration mode.

Step 5 **vfi** { *vfi-name* }**Example:**

```
RP/0/RP0/CPU0:router(config-l2vpn-bg-bd)# vfi v1
RP/0/RP0/CPU0:router(config-l2vpn-bg-bd-vfi)#
```

Configures the virtual forwarding interface (VFI) parameters and enters L2VPN bridge group bridge domain VFI configuration mode.

- Use the *vfi-name* argument to configure the name of the specified virtual forwarding interface.

Step 6 **exit****Example:**

```
RP/0/RP0/CPU0:router(config-l2vpn-bg-bd-vfi)# exit
RP/0/RP0/CPU0:router(config-l2vpn-bg-bd)#
```

Exits the current configuration mode.

Step 7 **neighbor** { *A.B.C.D* } { **pw-id** *value* }**Example:**

```
RP/0/RP0/CPU0:router(config-l2vpn-bg-bd)# neighbor 10.1.1.2 pw-id 1000
RP/0/RP0/CPU0:router(config-l2vpn-bg-bd-pw)#
```

Adds an access pseudowire port to a bridge domain or a pseudowire to a bridge virtual forwarding interface (VFI).

- Use the *A.B.C.D* argument to specify the IP address of the cross-connect peer.
- Use the **pw-id** keyword to configure the pseudowire ID and ID value. The range is 1 to 4294967295.

Step 8 Use the **commit** or **end** command.

commit - Saves the configuration changes and remains within the configuration session.

end - Prompts user to take one of these actions:

- **Yes** - Saves configuration changes and exits the configuration session.
- **No** - Exits the configuration session without committing the configuration changes.

- **Cancel** - Remains in the configuration mode, without committing the configuration changes.

Enabling Pseudowire Status TLV

When a pseudowire is setup, label distribution protocol (LDP) determines the method for signaling pseudowire status. Cisco IOS-XR provides a configuration option that allows you to enable pseudowire status type length value (TLV).



Note Unless pseudowire status TLV is explicitly enabled under L2VPN configuration, the default signaling method is Label Withdrawal. Pseudowire status TLV must be enabled on both local and remote PEs. If only one provider edge router is configured with the **pw-status tlv** command, then label withdrawal method is used.

Perform this task to enable pseudowire status TLV.

SUMMARY STEPS

1. **configure**
2. **l2vpn**
3. **pw-status tlv**
4. Use the **commit** or **end** command.

DETAILED STEPS

Step 1 **configure**

Example:

```
RP/0/RSP0/CPU0:router# configure
```

Enters the Global Configuration mode.

Step 2 **l2vpn**

Example:

```
RP/0/RP00/CPU0:router(config)# l2vpn
RP/0/RP00/CPU0:router(config-l2vpn)#
```

Enters L2VPN configuration mode.

Step 3 **pw-status tlv**

Example:

```
RP/0/RP00/CPU0:router(config-l2vpn)# pw-status tlv
```

Enables pseudowire status TLV.

Step 4 Use the **commit** or **end** command.

commit - Saves the configuration changes and remains within the configuration session.

end - Prompts user to take one of these actions:

- **Yes** - Saves configuration changes and exits the configuration session.
- **No** - Exits the configuration session without committing the configuration changes.
- **Cancel** - Remains in the configuration mode, without committing the configuration changes.

Configuring a Backup Pseudowire

Perform this task to configure a backup pseudowire for a point-to-point neighbor.

SUMMARY STEPS

1. **configure**
2. **l2vpn**
3. **xconnect group** *group-name*
4. **p2p** *xconnect-name*
5. **neighbor** *ip-address pw-id value*
6. **backup neighbor** *ip-address pw-id number*
7. Use the **commit** or **end** command.

DETAILED STEPS

Step 1 **configure**

Example:

```
RP/0/RP0/CPU0:router# configure
```

Enters the Global Configuration mode.

Step 2 **l2vpn**

Example:

```
RP/0/RP0/CPU0:router(config)# l2vpn
RP/0/RP0/CPU0:router(config-l2vpn)#
```

Enters L2VPN configuration mode.

Step 3 **xconnect group** *group-name*

Example:

```
RP/0/RP0/CPU0:router(config-l2vpn)# xconnect group A
RP/0/RP0/CPU0:router(config-l2vpn-xc)#
```

Enters the name of the cross-connect group.

Step 4 **p2p** *xconnect-name*

Example:

```
RP/0/RP0/CPU0:router(config-l2vpn-xc)# p2p rtrX_to_rtrY
RP/0/RP0/CPU0:router(config-l2vpn-xc-p2p)#
```

Enters a name for the point-to-point cross-connect.

Step 5 **neighbor** *ip-address* **pw-id** *value*

Example:

```
RP/0/RP0/CPU0:router(config-l2vpn-xc-p2p)# neighbor 10.0.0.1 pw-id 2
RP/0/RP0/CPU0:router(config-l2vpn-xc-p2p-pw)#
```

Configures the pseudowire segment for the cross-connect.

Step 6 **backup neighbor** *ip-address* **pw-id** *number*

Example:

```
RP/0/RP0/CPU0:router(config-l2vpn-xc-p2p)# backup neighbor 10.0.0.1 pw-id 2
RP/0/RP0/CPU0:router(config-l2vpn-xc-p2p-pw-backup)#
```

Configures the backup pseudowire for the cross-connect.

Step 7 Use the **commit** or **end** command.

commit - Saves the configuration changes and remains within the configuration session.

end - Prompts user to take one of these actions:

- **Yes** - Saves configuration changes and exits the configuration session.
- **No** - Exits the configuration session without committing the configuration changes.
- **Cancel** - Remains in the configuration mode, without committing the configuration changes.

Configuring Backup Disable Delay

The Backup Disable Delay function specifies the time for which the primary pseudowire in active state waits before it takes over for the backup pseudowire. Perform this task to configure a disable delay.

SUMMARY STEPS

1. **configure**
2. **l2vpn**
3. **pw-class** *class-name*
4. **backup disable delay** *seconds*
5. **exit**
6. **xconnect group** *group name*
7. **p2p** *xconnect name*
8. **neighbor** *ip-address* **pw-id** *number*
9. **pw-class** *class-name*
10. **backup neighbor** *ip-address* **pw-id** *number*
11. Use the **commit** or **end** command.

DETAILED STEPS

Step 1 **configure****Example:**

```
RP/0/RP0/CPU0:router# configure
```

Enters the Global Configuration mode.

Step 2 **l2vpn****Example:**

```
RP/0/RP0/CPU0:router (config) # l2vpn
RP/0/RP0/CPU0:router (config-l2vpn) #
```

Enters L2VPN configuration mode.

Step 3 **pw-class** *class-name***Example:**

```
RP/0/RP0/CPU0:router (config-l2vpn) # pw-class class_1
RP/0/RP0/CPU0:router (config-l2vpn-pwc) #
```

Configures the pseudowire class name.

Step 4 **backup disable delay** *seconds***Example:**

```
RP/0/RP0/CPU0:router (config-l2vpn-pwc) # backup disable delay 20
RP/0/RP0/CPU0:router (config-l2vpn-pwc) #
```

Specifies how long a backup pseudowire virtual circuit (VC) should wait before resuming operation after the primary pseudowire VC becomes nonfunctional.

Step 5 **exit****Example:**

```
RP/0/RP0/CPU0:router (config-l2vpn-pwc) # exit
```

Exits the pseudowire class submenu.

Step 6 **xconnect group** *group name***Example:**

```
RP/0/RP0/CPU0:router (config-l2vpn) # xconnect group A
RP/0/RP0/CPU0:router (config-l2vpn-xc) #
```

Enters the name of the cross-connect group.

Step 7 **p2p** *xconnect name*

Example:

```
RP/0/RP0/CPU0:router(config-l2vpn-xc)# p2p rtrX_to_rtrY
RP/0/RP0/CPU0:router(config-l2vpn-xc-p2p)#
```

Enters a name for the point-to-point cross-connect.

Step 8 **neighbor** *ip-address* **pw-id** *number***Example:**

```
RP/0/RP0/CPU0:router(config-l2vpn-xc-p2p)# neighbor 10.0.0.1 pw-id 2
RP/0/RP0/CPU0:router(config-l2vpn-xc-p2p-pw)#
```

Configures the pseudowire segment for the cross-connect.

Step 9 **pw-class** *class-name***Example:**

```
RP/0/RP0/CPU0:router(config-l2vpn-xc-p2p-pw)# pw-class class_1
RP/0/RP0/CPU0:router(config-l2vpn-xc-p2p-pw)#
```

Configures the pseudowire class name.

Step 10 **backup neighbor** *ip-address* **pw-id** *number***Example:**

```
RP/0/RP0/CPU0:router(config-l2vpn-xc-p2p-pw)# backup neighbor 10.0.0.1 pw-id 2
RP/0/RP0/CPU0:router(config-l2vpn-xc-p2p-pw-backup)#
```

Configures the backup pseudowire for the point-to-point neighbor.

Step 11 Use the **commit** or **end** command.

commit - Saves the configuration changes and remains within the configuration session.

end - Prompts user to take one of these actions:

- **Yes** - Saves configuration changes and exits the configuration session.
- **No** - Exits the configuration session without committing the configuration changes.
- **Cancel** - Remains in the configuration mode, without committing the configuration changes.

Associating Members with a Bridge Domain

After a bridge domain is created, perform this task to assign interfaces to the bridge domain. These types of bridge ports are associated with a bridge domain:

- Ethernet and VLAN
- VFI

SUMMARY STEPS

1. **configure**
2. **l2vpn**
3. **bridge group** *bridge group name*
4. **bridge-domain** *bridge-domain name*
5. **interface** *type interface-path-id*
6. (Optional) **static-mac-address** { *MAC-address* }
7. Use the **commit** or **end** command.

DETAILED STEPS**Step 1** **configure****Example:**

```
RP/0/RP0/CPU0:router# configure
```

Enters the Global Configuration mode.

Step 2 **l2vpn****Example:**

```
RP/0/RP0/CPU0:router(config)# l2vpn
```

Enters L2VPN configuration mode.

Step 3 **bridge group** *bridge group name***Example:**

```
RP/0/RP0/CPU0:router(config-l2vpn)# bridge group cisco
RP/0/RP0/CPU0:router(config-l2vpn-bg)#
```

Creates a bridge group so that it can contain bridge domains and then assigns network interfaces to the bridge domain.

Step 4 **bridge-domain** *bridge-domain name***Example:**

```
RP/0/RP0/CPU0:router(config-l2vpn-bg)# bridge-domain abc
RP/0/RP0/CPU0:router(config-l2vpn-bg-bd)#
```

Establishes a bridge domain and enters L2VPN bridge group bridge domain configuration mode.

Step 5 **interface** *type interface-path-id***Example:**

```
RP/0/RP0/CPU0:router(config-l2vpn-bg-bd)# interface GigabitEthernet 0/4/0/0
RP/0/RP0/CPU0:router(config-l2vpn-bg-bd-ac)#
```

Enters interface configuration mode and adds an interface to a bridge domain that allows packets to be forwarded and received from other interfaces that are part of the same bridge domain.

Step 6 (Optional) **static-mac-address** { *MAC-address* }

Example:

```
RP/0/RP0/CPU0:router(config-l2vpn-bg-bd-ac)# static-mac-address 1.1.1
RP/0/RP0/CPU0:router(config-l2vpn-bg-bd-ac)# exit
RP/0/RP0/CPU0:router(config-l2vpn-bg-bd)#
```

Configures the static MAC address to associate a remote MAC address with a pseudowire or any other bridge interface.

Step 7 Use the **commit** or **end** command.

commit - Saves the configuration changes and remains within the configuration session.

end - Prompts user to take one of these actions:

- **Yes** - Saves configuration changes and exits the configuration session.
- **No** - Exits the configuration session without committing the configuration changes.
- **Cancel** - Remains in the configuration mode, without committing the configuration changes.

Configuring Bridge Domain Parameters

To configure bridge domain parameters, associate these parameters with a bridge domain:

- **Maximum transmission unit (MTU)**—Specifies that all members of a bridge domain have the same MTU. The bridge domain member with a different MTU size is not used by the bridge domain even though it is still associated with a bridge domain.
- **Flooding**—Flooding is enabled always.

SUMMARY STEPS

1. **configure**
2. **l2vpn**
3. **bridge group** *bridge-group-name*
4. **bridge-domain** *bridge-domain-name*
5. **flooding disable**
6. **mtu** *bytes*
7. Use the **commit** or **end** command.

DETAILED STEPS

Step 1 **configure**

Example:

```
RP/0/RP0/CPU0:router# configure
```

Enters the Global Configuration mode.

Step 2 l2vpn

Example:

```
RP/0/RP0/CPU0:router(config)# l2vpn
RP/0/RP0/CPU0:router(config-l2vpn)#
```

Enters the l2vpn configuration mode.

Step 3 bridge group *bridge-group-name*

Example:

```
RP/0/RP0/CPU0:router(config-l2vpn)# bridge group cisco
RP/0/RP0/CPU0:router(config-l2vpn-bg)#
```

Creates a bridge group so that it can contain bridge domains and then assigns network interfaces to the bridge domain.

Step 4 bridge-domain *bridge-domain-name*

Example:

```
RP/0/RP0/CPU0:router(config-l2vpn-bg)# bridge-domain abc
RP/0/RP0/CPU0:router(config-l2vpn-bg-bd)#
```

Establishes a bridge domain and enters l2vpn bridge group bridge domain configuration mode.

Step 5 flooding disable

Example:

```
RP/0/RP0/CPU0:router(config-l2vpn-bg-bd)# flooding disable
RP/0/RP0/CPU0:router(config-l2vpn-bg-bd)#
```

Disables flooding.

Step 6 mtu *bytes*

Example:

```
RP/0/RP0/CPU0:router(config-l2vpn-bg-bd)# mtu 1000
```

Adjusts the maximum packet size or maximum transmission unit (MTU) size for the bridge domain.

- Use the *bytes* argument to specify the MTU size, in bytes. The range is from 64 to 65535.

Step 7 Use the **commit** or **end** command.

commit - Saves the configuration changes and remains within the configuration session.

end - Prompts user to take one of these actions:

- **Yes** - Saves configuration changes and exits the configuration session.
- **No** - Exits the configuration session without committing the configuration changes.

- **Cancel** - Remains in the configuration mode, without committing the configuration changes.

Disabling a Bridge Domain

Perform this task to disable a bridge domain. When a bridge domain is disabled, all VFI that are associated with the bridge domain are disabled. You are still able to attach or detach members to the bridge domain and the VFI that are associated with the bridge domain.

SUMMARY STEPS

1. **configure**
2. **l2vpn**
3. **bridge group** *bridge group name*
4. **bridge-domain** *bridge-domain name*
5. **shutdown**
6. Use the **commit** or **end** command.

DETAILED STEPS

Step 1 **configure**

Example:

```
RP/0/RP0/CPU0:router# configure
```

Enters the Global Configuration mode.

Step 2 **l2vpn**

Example:

```
RP/0/RP0/CPU0:router(config)# l2vpn
RP/0/RP0/CPU0:router(config-l2vpn)#
```

Enters L2VPN configuration mode.

Step 3 **bridge group** *bridge group name*

Example:

```
RP/0/RP0/CPU0:router(config-l2vpn)# bridge group csco
RP/0/RP0/CPU0:router(config-l2vpn-bg)#
```

Creates a bridge group so that it can contain bridge domains and then assigns network interfaces to the bridge domain.

Step 4 **bridge-domain** *bridge-domain name*

Example:

```
RP/0/RP0/CPU0:router(config-l2vpn-bg)# bridge-domain abc
```

```
RP/0/RP0/CPU0:router(config-l2vpn-bg-bd) #
```

Establishes a bridge domain and enters l2vpn bridge group bridge domain configuration mode.

Step 5 shutdown

Example:

```
RP/0/RP0/CPU0:router(config-l2vpn-bg-bd) # shutdown
```

Shuts down a bridge domain to bring the bridge and all attachment circuits and pseudowires under it to admin down state.

Step 6 Use the **commit** or **end** command.

commit - Saves the configuration changes and remains within the configuration session.

end - Prompts user to take one of these actions:

- **Yes** - Saves configuration changes and exits the configuration session.
- **No** - Exits the configuration session without committing the configuration changes.
- **Cancel** - Remains in the configuration mode, without committing the configuration changes.

Configuring a Layer 2 Virtual Forwarding Instance

These topics describe how to configure a Layer 2 virtual forwarding instance (VFI):

Creating the Virtual Forwarding Instance

Perform this task to create a Layer 2 Virtual Forwarding Instance (VFI) on all provider edge devices under the bridge domain.

SUMMARY STEPS

1. **configure**
2. **l2vpn**
3. **bridge group** *bridge group name*
4. **bridge-domain** *bridge-domain name*
5. **vfi** *{vfi-name}*
6. Use the **commit** or **end** command.

DETAILED STEPS

Step 1 configure

Example:

```
RP/0/RP0/CPU0:router# configure
```

Enters the Global Configuration mode.

Step 2 l2vpn

Example:

```
RP/0/RP0/CPU0:router(config)# l2vpn
RP/0/RP0/CPU0:router(config-l2vpn)#
```

Enters L2VPN configuration mode.

Step 3 **bridge group** *bridge group name***Example:**

```
RP/0/RP0/CPU0:router(config-l2vpn)# bridge group cisco
RP/0/RP0/CPU0:router(config-l2vpn-bg)#
```

Creates a bridge group so that it can contain bridge domains and then assigns network interfaces to the bridge domain.

Step 4 **bridge-domain** *bridge-domain name***Example:**

```
RP/0/RP0/CPU0:router(config-l2vpn-bg)# bridge-domain abc
RP/0/RP0/CPU0:router(config-l2vpn-bg-bd)#
```

Establishes a bridge domain and enters L2VPN bridge group bridge domain configuration mode.

Step 5 **vfi** {*vfi-name*}**Example:**

```
RP/0/RP0/CPU0:router(config-l2vpn-bg-bd)# vfi v1
RP/0/RP0/CPU0:router(config-l2vpn-bg-bd-vfi)#
```

Configures virtual forwarding interface (VFI) parameters and enters L2VPN bridge group bridge domain VFI configuration mode.

Step 6 Use the **commit** or **end** command.

commit - Saves the configuration changes and remains within the configuration session.

end - Prompts user to take one of these actions:

- **Yes** - Saves configuration changes and exits the configuration session.
- **No** - Exits the configuration session without committing the configuration changes.
- **Cancel** - Remains in the configuration mode, without committing the configuration changes.

Associating Pseudowires with the Virtual Forwarding Instance

After a VFI is created, perform this task to associate one or more pseudowires with the VFI.

SUMMARY STEPS

1. **configure**
2. **l2vpn**
3. **bridge group** *bridge-group-name*
4. **bridge-domain** *bridge-domain-name*
5. **vfi** { *vfi name* }

6. **neighbor** { *A.B.C.D* } { **pw-id** *value* }
7. Use the **commit** or **end** command.

DETAILED STEPS

Step 1 **configure**

Example:

```
RP/0/RP0/CPU0:router# configure
```

Enters the Global Configuration mode.

Step 2 **l2vpn**

Example:

```
RP/0/RP0/CPU0:router(config)# l2vpn
RP/0/RP0/CPU0:router(config-l2vpn)#
```

Enters L2VPN configuration mode.

Step 3 **bridge group** *bridge-group-name*

Example:

```
RP/0/RP0/CPU0:router(config-l2vpn)# bridge group cisco
RP/0/RP0/CPU0:router(config-l2vpn-bg)#
```

Creates a bridge group so that it can contain bridge domains and then assigns network interfaces to the bridge domain.

Step 4 **bridge-domain** *bridge-domain-name*

Example:

```
RP/0/RP0/CPU0:router(config-l2vpn-bg)# bridge-domain abc
RP/0/RP0/CPU0:router(config-l2vpn-bg-bd)#
```

Establishes a bridge domain and enters L2VPN bridge group bridge domain configuration mode.

Step 5 **vfi** { *vfi name* }

Example:

```
RP/0/RP0/CPU0:router(config-l2vpn-bg-bd)# vfi v1
RP/0/RP0/CPU0:router(config-l2vpn-bg-bd-vfi)#
```

Configures virtual forwarding interface (VFI) parameters and enters L2VPN bridge group bridge domain VFI configuration mode.

Step 6 **neighbor** { *A.B.C.D* } { **pw-id** *value* }

Example:

```
RP/0/RP0/CPU0:router(config-l2vpn-bg-bd-vfi)# neighbor 10.1.1.2 pw-id 1000
```

```
RP/0/RP0/CPU0:router(config-l2vpn-bg-bd-vfi-pw)#
```

Adds a pseudowire port to a bridge domain or a pseudowire to a bridge virtual forwarding interface (VFI).

- Use the *A.B.C.D* argument to specify the IP address of the cross-connect peer.
- Use the **pw-id** keyword to configure the pseudowire ID and ID value. The range is 1 to 4294967295.

Step 7 Use the **commit** or **end** command.

commit - Saves the configuration changes and remains within the configuration session.

end - Prompts user to take one of these actions:

- **Yes** - Saves configuration changes and exits the configuration session.
- **No** - Exits the configuration session without committing the configuration changes.
- **Cancel** - Remains in the configuration mode, without committing the configuration changes.

Associating a Virtual Forwarding Instance to a Bridge Domain

Perform this task to associate a VFI to be a member of a bridge domain.

SUMMARY STEPS

1. **configure**
2. **l2vpn**
3. **bridge group** *bridge group name*
4. **bridge-domain** *bridge-domain name*
5. **vfi** { *vfi name* }
6. **neighbor** { *A.B.C.D* } { **pw-id** *value* }
7. **static-mac-address** { *MAC-address* }
8. Use the **commit** or **end** command.

DETAILED STEPS

Step 1 **configure**

Example:

```
RP/0/RP0/CPU0:router# configure
```

Enters the Global Configuration mode.

Step 2 **l2vpn**

Example:

```
RP/0/RP0/CPU0:router(config)# l2vpn
RP/0/RP0/CPU0:router(config-l2vpn)#
```

Enters the L2VPN configuration mode.

Step 3 **bridge group** *bridge group name***Example:**

```
RP/0/RP0/CPU0:router(config-l2vpn)# bridge group cisco
RP/0/RP0/CPU0:router(config-l2vpn-bg)#
```

Creates a bridge group so that it can contain bridge domains and then assigns network interfaces to the bridge domain.

Step 4 **bridge-domain** *bridge-domain name***Example:**

```
RP/0/RP0/CPU0:router(config-l2vpn-bg)# bridge-domain abc
RP/0/RP0/CPU0:router(config-l2vpn-bg-bd)#
```

Establishes a bridge domain and enters L2VPN bridge group bridge domain configuration mode.

Step 5 **vfi** { *vfi name* }**Example:**

```
RP/0/RP0/CPU0:router(config-l2vpn-bg-bd)# vfi v1
RP/0/RP0/CPU0:router(config-l2vpn-bg-bd-vfi)#
```

Configures virtual forwarding interface (VFI) parameters and enters L2VPN bridge group bridge domain VFI configuration mode.

Step 6 **neighbor** { *A.B.C.D* } { **pw-id** *value* }**Example:**

```
RP/0/RP0/CPU0:router(config-l2vpn-bg-bd-vfi)# neighbor 10.1.1.2 pw-id 1000
RP/0/RP0/CPU0:router(config-l2vpn-bg-bd-vfi-pw)#
```

Adds a pseudowire port to a bridge domain or a pseudowire to a bridge virtual forwarding interface (VFI).

- Use the *A.B.C.D* argument to specify the IP address of the cross-connect peer.
- Use the **pw-id** keyword to configure the pseudowire ID and ID value. The range is 1 to 4294967295.

Step 7 **static-mac-address** { *MAC-address* }**Example:**

```
RP/0/RP0/CPU0:router(config-l2vpn-bg-bd-vfi-pw)# static-mac-address 1.1.1
```

Configures the static MAC address to associate a remote MAC address with a pseudowire or any other bridge interface.

Step 8 Use the **commit** or **end** command.

commit - Saves the configuration changes and remains within the configuration session.

end - Prompts user to take one of these actions:

- **Yes** - Saves configuration changes and exits the configuration session.
- **No** - Exits the configuration session without committing the configuration changes.

- **Cancel** - Remains in the configuration mode, without committing the configuration changes.

Attaching Pseudowire Classes to Pseudowires

Perform this task to attach a pseudowire class to a pseudowire.

SUMMARY STEPS

1. **configure**
2. **l2vpn**
3. **bridge group** *bridge group name*
4. **bridge-domain** *bridge-domain name*
5. **vfi** { *vfi-name* }
6. **neighbor** { *A.B.C.D* } { **pw-id** *value* }
7. **pw-class** { *class-name* }
8. Use the **commit** or **end** command.

DETAILED STEPS

Step 1 **configure**

Example:

```
RP/0/RP0/CPU0:router# configure
```

Enters the Global Configuration mode.

Step 2 **l2vpn**

Example:

```
RP/0/RP0/CPU0:router(config)# l2vpn
RP/0/RP0/CPU0:router(config-l2vpn)#
```

Enters the L2VPN configuration mode.

Step 3 **bridge group** *bridge group name*

Example:

```
RP/0/RP0/CPU0:router(config-l2vpn)# bridge group cisco
RP/0/RP0/CPU0:router(config-l2vpn-bg)#
```

Creates a bridge group so that it can contain bridge domains and then assigns network interfaces to the bridge domain.

Step 4 **bridge-domain** *bridge-domain name*

Example:

```
RP/0/RP0/CPU0:router(config-l2vpn-bg)# bridge-domain abc
```

```
RP/0/RP0/CPU0:router(config-l2vpn-bg-bd)#
```

Establishes a bridge domain and enters L2VPN bridge group bridge domain configuration mode.

Step 5 **vfi** { *vfi-name* }

Example:

```
RP/0/RP0/CPU0:router(config-l2vpn-bg-bd)# vfi v1
RP/0/RP0/CPU0:router(config-l2vpn-bg-bd-vfi)#
```

Configures virtual forwarding interface (VFI) parameters and enters L2VPN bridge group bridge domain VFI configuration mode.

Step 6 **neighbor** { *A.B.C.D* } { **pw-id** *value* }

Example:

```
RP/0/RP0/CPU0:router(config-l2vpn-bg-bd-vfi)# neighbor 10.1.1.2 pw-id 1000
RP/0/RP0/CPU0:router(config-l2vpn-bg-bd-vfi-pw)#
```

Adds a pseudowire port to a bridge domain or a pseudowire to a bridge virtual forwarding interface (VFI).

- Use the *A.B.C.D* argument to specify the IP address of the cross-connect peer.
- Use the **pw-id** keyword to configure the pseudowire ID and ID value. The range is 1 to 4294967295.

Step 7 **pw-class** { *class-name* }

Example:

```
RP/0/RP0/CPU0:router(config-l2vpn-bg-bd-vfi-pw)# pw-class canada
```

Configures the pseudowire class template name to use for the pseudowire.

Step 8 Use the **commit** or **end** command.

commit - Saves the configuration changes and remains within the configuration session.

end - Prompts user to take one of these actions:

- **Yes** - Saves configuration changes and exits the configuration session.
- **No** - Exits the configuration session without committing the configuration changes.
- **Cancel** - Remains in the configuration mode, without committing the configuration changes.

Configuring Pseudowires Using Static Labels

Perform this task to configure the Any Transport over Multiprotocol (AToM) pseudowires by using the static labels. A pseudowire becomes a static AToM pseudowire by setting the MPLS static labels to local and remote.

SUMMARY STEPS

1. **configure**
2. **l2vpn**

3. **bridge group** *bridge-group-name*
4. **bridge-domain** *bridge-domain-name*
5. **vfi** { *vfi-name* }
6. **neighbor** { *A.B.C.D* } { **pw-id** *value* }
7. **mpls static label** { **local** *value* } { **remote** *value* }
8. Use the **commit** or **end** command.

DETAILED STEPS

Step 1 **configure**

Example:

```
RP/0/RP0/CPU0:router# configure
```

Enters the Global Configuration mode.

Step 2 **l2vpn**

Example:

```
RP/0/RP0/CPU0:router(config)# l2vpn
RP/0/RP0/CPU0:router(config-l2vpn)#
```

Enters the L2VPN configuration mode.

Step 3 **bridge group** *bridge-group-name*

Example:

```
RP/0/RP0/CPU0:router(config-l2vpn)# bridge group cisco
RP/0/RP0/CPU0:router(config-l2vpn-bg)#
```

Creates a bridge group so that it can contain bridge domains and then assigns network interfaces to the bridge domain.

Step 4 **bridge-domain** *bridge-domain-name*

Example:

```
RP/0/RP0/CPU0:router(config-l2vpn-bg)# bridge-domain abc
RP/0/RP0/CPU0:router(config-l2vpn-bg-bd)#
```

Establishes a bridge domain and enters L2VPN bridge group bridge domain configuration mode.

Step 5 **vfi** { *vfi-name* }

Example:

```
RP/0/RP0/CPU0:router(config-l2vpn-bg-bd)# vfi v1
RP/0/RP0/CPU0:router(config-l2vpn-bg-bd-vfi)#
```

Configures virtual forwarding interface (VFI) parameters and enters L2VPN bridge group bridge domain VFI configuration mode.

Step 6 `neighbor { A.B.C.D } { pw-id value }`

Example:

```
RP/0/RP0/CPU0:router(config-l2vpn-bg-bd-vfi)# neighbor 10.1.1.2 pw-id 1000
RP/0/RP0/CPU0:router(config-l2vpn-bg-bd-vfi-pw)#
```

Adds a pseudowire port to a bridge domain or a pseudowire to a bridge virtual forwarding interface (VFI).

- Use the *A.B.C.D* argument to specify the IP address of the cross-connect peer.
- Use the **pw-id** keyword to configure the pseudowire ID and ID value. The range is 1 to 4294967295.

Step 7 `mpls static label { local value } { remote value }`

Example:

```
RP/0/RP0/CPU0:router(config-l2vpn-bg-bd-vfi-pw)# mpls static label local 800 remote 500
```

Configures the MPLS static labels and the static labels for the pseudowire configuration. You can set the local and remote pseudowire labels.

Step 8 Use the **commit** or **end** command.

commit - Saves the configuration changes and remains within the configuration session.

end - Prompts user to take one of these actions:

- **Yes** - Saves configuration changes and exits the configuration session.
- **No** - Exits the configuration session without committing the configuration changes.
- **Cancel** - Remains in the configuration mode, without committing the configuration changes.

Disabling a Virtual Forwarding Instance

Perform this task to disable a VFI. When a VFI is disabled, all the previously established pseudowires that are associated with the VFI are disconnected. LDP advertisements are sent to withdraw the MAC addresses that are associated with the VFI. However, you can still attach or detach attachment circuits with a VFI after a shutdown.

SUMMARY STEPS

1. **configure**
2. **l2vpn**
3. **bridge group** *bridge group name*
4. **bridge-domain** *bridge-domain name*
5. **vfi** { *vfi-name* }
6. **shutdown**
7. Use the **commit** or **end** command.
8. **show l2vpn bridge-domain** [**detail**]

DETAILED STEPS

Step 1 **configure**

Example:

```
RP/0/RP0/CPU0:router# configure
```

Enters the Global Configuration mode.

Step 2 **l2vpn**

Example:

```
RP/0/RP0/CPU0:router(config)# l2vpn
RP/0/RP0/CPU0:router(config-l2vpn)#
```

Enters the L2VPN configuration mode.

Step 3 **bridge group** *bridge group name*

Example:

```
RP/0/RP0/CPU0:router(config-l2vpn)# bridge group cisco
RP/0/RP0/CPU0:router(config-l2vpn-bg)#
```

Creates a bridge group so that it can contain bridge domains and then assigns network interfaces to the bridge domain.

Step 4 **bridge-domain** *bridge-domain name*

Example:

```
RP/0/RP0/CPU0:router(config-l2vpn-bg)# bridge-domain abc
RP/0/RP0/CPU0:router(config-l2vpn-bg-bd)#
```

Establishes a bridge domain and enters L2VPN bridge group bridge domain configuration mode.

Step 5 **vfi** { *vfi-name* }

Example:

```
RP/0/RP0/CPU0:router(config-l2vpn-bg-bd)# vfi v1
RP/0/RP0/CPU0:router(config-l2vpn-bg-bd-vfi)#
```

Configures virtual forwarding interface (VFI) parameters and enters L2VPN bridge group bridge domain VFI configuration mode.

Step 6 **shutdown**

Example:

```
RP/0/RP0/CPU0:router(config-l2vpn-bg-bd-vfi)# shutdown
```

Disables the virtual forwarding interface (VFI).

Step 7 Use the **commit** or **end** command.

commit - Saves the configuration changes and remains within the configuration session.

end - Prompts user to take one of these actions:

- **Yes** - Saves configuration changes and exits the configuration session.
- **No** - Exits the configuration session without committing the configuration changes.
- **Cancel** - Remains in the configuration mode, without committing the configuration changes.

Step 8 **show l2vpn bridge-domain [detail]**

Example:

```
RP/0/RP0/CPU0:router# show l2vpn bridge-domain detail
```

Displays the state of the VFI. For example, if you shut down the VFI, the VFI is shown as shut down under the bridge domain.

Configuring the MAC Address-related Parameters

These topics describe how to configure the MAC address-related parameters:

The MAC table attributes are set for the bridge domains.

Configuring the MAC Address Source-based Learning

Perform this task to configure the MAC address source-based learning.

SUMMARY STEPS

1. **configure**
2. **l2vpn**
3. **bridge group** *bridge group name*
4. **bridge-domain** *bridge-domainname*
5. **mac**
6. **learning disable**
7. Use the **commit** or **end** command.
8. **show l2vpn bridge-domain [detail]**

DETAILED STEPS

Step 1 **configure**

Example:

```
RP/0/RP0/CPU0:router# configure
```

Enters the Global Configuration mode.

Step 2 **l2vpn**

Example:

```
RP/0/RP0/CPU0:router(config)# l2vpn
RP/0/RP0/CPU0:router(config-l2vpn)#
```

Enters the L2VPN configuration mode.

Step 3 **bridge group** *bridge group name***Example:**

```
RP/0/RP0/CPU0:router(config-l2vpn)# bridge group cisco
RP/0/RP0/CPU0:router(config-l2vpn-bg)#
```

Creates a bridge group so that it can contain bridge domains and then assigns network interfaces to the bridge domain.

Step 4 **bridge-domain** *bridge-domainname***Example:**

```
RP/0/RP0/CPU0:router(config-l2vpn-bg)# bridge-domain abc
RP/0/RP0/CPU0:router(config-l2vpn-bg-bd)#
```

Establishes a bridge domain and enters L2VPN bridge group bridge domain configuration mode.

Step 5 **mac****Example:**

```
RP/0/RP0/CPU0:router(config-l2vpn-bg-bd)# mac
RP/0/RP0/CPU0:router(config-l2vpn-bg-bd-mac)#
```

Enters L2VPN bridge group bridge domain MAC configuration mode.

Step 6 **learning disable****Example:**

```
RP/0/RP0/CPU0:router(config-l2vpn-bg-bd-mac)# learning disable
```

Overrides the MAC learning configuration of a parent bridge or sets the MAC learning configuration of a bridge.

Step 7 Use the **commit** or **end** command.

commit - Saves the configuration changes and remains within the configuration session.

end - Prompts user to take one of these actions:

- **Yes** - Saves configuration changes and exits the configuration session.
- **No** - Exits the configuration session without committing the configuration changes.
- **Cancel** - Remains in the configuration mode, without committing the configuration changes.

Step 8 **show l2vpn bridge-domain** [**detail**]**Example:**

```
RP/0/RP0/CPU0:router# show l2vpn bridge-domain detail
```

Displays the details that the MAC address source-based learning is disabled on the bridge.

Disabling the MAC Address Withdrawal

Perform this task to disable the MAC address withdrawal for a specified bridge domain.

SUMMARY STEPS

1. **configure**
2. **l2vpn**
3. **bridge group** *bridge group name*
4. **bridge-domain** *bridge-domain name*
5. **mac**
6. **withdraw { access-pw disable | disable }**
7. Use the **commit** or **end** command.
8. **show l2vpn bridge-domain [detail]**

DETAILED STEPS

Step 1 **configure**

Example:

```
RP/0/RP0/CPU0:router# configure
```

Enters the Global Configuration mode.

Step 2 **l2vpn**

Example:

```
RP/0/RP0/CPU0:router(config)# l2vpn
RP/0/RP0/CPU0:router(config-l2vpn)#
```

Enters L2VPN configuration mode.

Step 3 **bridge group** *bridge group name*

Example:

```
RP/0/RP0/CPU0:router(config-l2vpn)# bridge group cisco
RP/0/RP0/CPU0:router(config-l2vpn-bg)#
```

Creates a bridge group so that it can contain bridge domains and then assigns network interfaces to the bridge domain.

Step 4 **bridge-domain** *bridge-domain name*

Example:

```
RP/0/RP0/CPU0:router(config-l2vpn-bg)# bridge-domain abc
RP/0/RP0/CPU0:router(config-l2vpn-bg-bd)#
```

Establishes a bridge domain and enters L2VPN bridge group bridge domain configuration mode.

Step 5 **mac**

Example:

```
RP/0/RP0/CPU0:router(config-l2vpn-bg-bd)# mac
RP/0/RP0/CPU0:router(config-l2vpn-bg-bd-mac)#
```

Enters L2VPN bridge group bridge domain MAC configuration mode.

Step 6 **withdraw { access-pw disable | disable }**

Example:

```
RP/0/RP0/CPU0:router(config-l2vpn-bg-bd-mac)# withdraw access-pw disable
```

Disables the MAC address withdrawal for the specified bridge domain.

Note Mac address withdrawal is generated when the access pseudowire is not operational.

Step 7 Use the **commit** or **end** command.

commit - Saves the configuration changes and remains within the configuration session.

end - Prompts user to take one of these actions:

- **Yes** - Saves configuration changes and exits the configuration session.
- **No** - Exits the configuration session without committing the configuration changes.
- **Cancel** - Remains in the configuration mode, without committing the configuration changes.

Step 8 **show l2vpn bridge-domain [detail]**

Example:

```
RP/0/RP0/CPU0:router# show l2vpn bridge-domain detail
```

Displays detailed sample output to specify that the MAC address withdrawal is enabled. In addition, the sample output displays the number of MAC withdrawal messages that are sent over or received from the pseudowire.

The following sample output shows the MAC address withdrawal fields:

```
RP/0/0/CPU0:router# show l2vpn bridge-domain detail
```

```
Bridge group: siva_group, bridge-domain: siva_bd, id: 0, state: up, ShgId: 0, MSTi: 0
MAC Learning: enabled
MAC withdraw: enabled
Flooding:
  Broadcast & Multicast: enabled
  Unknown Unicast: enabled
MAC address aging time: 300 s Type: inactivity
MAC address limit: 4000, Action: none, Notification: syslog
MAC limit reached: no
Security: disabled
DHCPv4 Snooping: disabled
```

```

MTU: 1500
MAC Filter:  Static MAC addresses:
ACs: 1 (1 up), VFIs: 1, PWs: 2 (1 up)
List of ACs:
  AC: GigabitEthernet0/4/0/1, state is up
    Type Ethernet
    MTU 1500; XC ID 0x5000001; interworking none; MSTi 0 (unprotected)
    MAC Learning: enabled
    MAC withdraw: disabled
    Flooding:
      Broadcast & Multicast: enabled
      Unknown Unicast: enabled
    MAC address aging time: 300 s Type: inactivity
    MAC address limit: 4000, Action: none, Notification: syslog
    MAC limit reached: no
    Security: disabled
    DHCPv4 Snooping: disabled
    Static MAC addresses:
    Statistics:
      packet totals: receive 6,send 0
      byte totals: receive 360,send 4
List of Access PWs:
List of VFIs:
  VFI siva_vfi
    PW: neighbor 10.0.0.1, PW ID 1, state is down ( local ready )
    PW class not set, XC ID 0xff000001
    Encapsulation MPLS, protocol LDP
    PW type Ethernet, control word enabled, interworking none
    PW backup disable delay 0 sec
    Sequencing not set
      MPLS          Local          Remote
      -----
      Label          30005          unknown
      Group ID       0x0            0x0
      Interface      siva/vfi       unknown
      MTU            1500          unknown
      Control word   enabled        unknown
      PW type        Ethernet      unknown
      -----
Create time: 19/11/2007 15:20:14 (00:25:25 ago)
Last time status changed: 19/11/2007 15:44:00 (00:01:39 ago)
MAC withdraw message: send 0 receive 0

```

Configuring the MAC Address Limit

Perform this task to configure the parameters for the MAC address limit.

SUMMARY STEPS

1. **configure**
2. **l2vpn**
3. **bridge group** *bridge group name*
4. **bridge-domain** *bridge-domain name*
5. **(Optional) interface type** *interface_id*
6. **mac**
7. **limit**
8. **maximum** { *value* }

9. **action** { **flood** | **no-flood** | **shutdown** }
10. **notification** { **both** | **none** | **trap** }
11. **mac limit threshold** *80*
12. Use the **commit** or **end** command.
13. **show l2vpn bridge-domain** [**detail**]

DETAILED STEPS

Step 1 **configure**

Example:

```
RP/0/RP0/CPU0:router# configure
```

Enters the Global Configuration mode.

Step 2 **l2vpn**

Example:

```
RP/0/RP0/CPU0:router(config)# l2vpn
RP/0/RP0/CPU0:router(config-l2vpn)#
```

Enters the L2VPN configuration mode.

Step 3 **bridge group** *bridge group name*

Example:

```
RP/0/RP0/CPU0:router(config-l2vpn)# bridge group cisco
RP/0/RP0/CPU0:router(config-l2vpn-bg)#
```

Creates a bridge group so that it can contain bridge domains and then assigns network interfaces to the bridge domain.

Step 4 **bridge-domain** *bridge-domain name*

Example:

```
RP/0/RP0/CPU0:router(config-l2vpn-bg)# bridge-domain abc
RP/0/RP0/CPU0:router(config-l2vpn-bg-bd)#
```

Establishes a bridge domain and enters L2VPN bridge group bridge domain configuration mode.

Step 5 *(Optional)* **interface** *type interface_id*

Example:

```
RP/0/RP0/CPU0:router(config-l2vpn-bg-bd)# interface gigabitEthernet 0/2/0/1
RP/0/RP0/CPU0:router(config-l2vpn-bg-bd-ac)#
```

Enters the interface configuration mode of the specified interface and adds this interface as the bridge domain member interface.

Note Run this step if you want to configure the MAC address limit only for a specific interface. The further steps show the router prompt displayed when you have skipped this step to configure the MAC address limit at the bridge domain level.

Step 6 **mac**

Example:

```
RP/0/RP0/CPU0:router(config-l2vpn-bg-bd)# mac
RP/0/RP0/CPU0:router(config-l2vpn-bg-bd-mac)#
```

Enters L2VPN bridge group bridge domain MAC configuration mode.

Step 7 **limit**

Example:

```
RP/0/RP0/CPU0:router(config-l2vpn-bg-bd-mac)# limit
RP/0/RP0/CPU0:router(config-l2vpn-bg-bd-mac-limit)#
```

Sets the MAC address limit for action, maximum, and notification and enters L2VPN bridge group bridge domain MAC limit configuration mode.

Step 8 **maximum { value }**

Example:

```
RP/0/RP0/CPU0:router(config-l2vpn-bg-bd-mac-limit)# maximum 5000
```

Configures the specified action when the number of MAC addresses learned on a bridge is reached.

Step 9 **action { flood | no-flood | shutdown }**

Example:

```
RP/0/RP0/CPU0:router(config-l2vpn-bg-bd-mac-limit)# action flood
```

Configures the bridge behavior when the number of learned MAC addresses exceed the MAC limit configured.

Step 10 **notification { both | none | trap }**

Example:

```
RP/0/RP0/CPU0:router(config-l2vpn-bg-bd-mac-limit)# notification both
```

Specifies the type of notification that is sent when the number of learned MAC addresses exceeds the configured limit.

Step 11 **mac limit threshold 80**

Example:

```
RP/0/RP0/CPU0:router(config-l2vpn)# mac limit threshold 80
```

Configures the MAC limit threshold. The default is 75% of MAC address limit configured in step 8.

- Step 12** Use the **commit** or **end** command.
- commit** - Saves the configuration changes and remains within the configuration session.
- end** - Prompts user to take one of these actions:
- **Yes** - Saves configuration changes and exits the configuration session.
 - **No** - Exits the configuration session without committing the configuration changes.
 - **Cancel** - Remains in the configuration mode, without committing the configuration changes.

Step 13 **show l2vpn bridge-domain [detail]**

Example:

```
RP/0/RP0/CPU0:router# show l2vpn bridge-domain detail
```

Displays the details about the MAC address limit.

Configuring the MAC Address Aging

Perform this task to configure the parameters for MAC address aging.

SUMMARY STEPS

1. **configure**
2. **l2vpn**
3. **bridge group** *bridge-group-name*
4. **bridge-domain** *bridge-domain-name*
5. **mac**
6. **aging**
7. **time** { *seconds* }
8. Use the **commit** or **end** command.
9. **show l2vpn bridge-domain [detail]**

DETAILED STEPS

Step 1 **configure**

Example:

```
RP/0/RP0/CPU0:router# configure
```

Enters the Global Configuration mode.

Step 2 **l2vpn**

Example:

```
RP/0/RP0/CPU0:router(config)# l2vpn
```

```
RP/0/RP0/CPU0:router(config-l2vpn)#
```

Enters the L2VPN configuration mode.

Step 3 **bridge group** *bridge-group-name*

Example:

```
RP/0/RP0/CPU0:router(config-l2vpn)# bridge group cisco
RP/0/RP0/CPU0:router(config-l2vpn-bg)#
```

Creates a bridge group so that it can contain bridge domains and then assigns network interfaces to the bridge domain.

Step 4 **bridge-domain** *bridge-domain-name*

Example:

```
RP/0/RP0/CPU0:router(config-l2vpn-bg)# bridge-domain abc
RP/0/RP0/CPU0:router(config-l2vpn-bg-bd)#
```

Establishes a bridge domain and enters L2VPN bridge group bridge domain configuration mode.

Step 5 **mac**

Example:

```
RP/0/RP0/CPU0:router(config-l2vpn-bg-bd)# mac
RP/0/RP0/CPU0:router(config-l2vpn-bg-bd-mac)#
```

Enters L2VPN bridge group bridge domain MAC configuration mode.

Step 6 **aging**

Example:

```
RP/0/RP0/CPU0:router(config-l2vpn-bg-bd-mac)# aging
RP/0/RP0/CPU0:router(config-l2vpn-bg-bd-mac-aging)#
```

Enters the MAC aging configuration submode to set the aging parameters such as time and type.

Step 7 **time** { *seconds* }

Example:

```
RP/0/RP0/CPU0:router(config-l2vpn-bg-bd-mac-aging)# time 300
```

Configures the maximum aging time.

- Use the *seconds* argument to specify the maximum age of the MAC address table entry. The range is from 300 to 30000 seconds. Aging time is counted from the last time that the switch saw the MAC address. The default value is 300 seconds.

Step 8 Use the **commit** or **end** command.

commit - Saves the configuration changes and remains within the configuration session.

end - Prompts user to take one of these actions:

- **Yes** - Saves configuration changes and exits the configuration session.
- **No** - Exits the configuration session without committing the configuration changes.
- **Cancel** - Remains in the configuration mode, without committing the configuration changes.

Step 9 **show l2vpn bridge-domain [detail]**

Example:

```
RP/0/RP0/CPU0:router# show l2vpn bridge-domain detail
```

Displays the details about the aging fields.

Disabling MAC Flush at the Bridge Port Level

Perform this task to disable the MAC flush at the bridge domain level.

You can disable the MAC flush at the bridge domain or bridge port level. By default, the MACs learned on a specific port are immediately flushed, when that port becomes nonfunctional.

SUMMARY STEPS

1. **configure**
2. **l2vpn**
3. **bridge group** *bridge-group-name*
4. **bridge-domain** *bridge-domain-name*
5. **mac**
6. **port-down flush disable**
7. Use the **commit** or **end** command.

DETAILED STEPS

Step 1 **configure**

Example:

```
RP/0/RP0/CPU0:router# configure
```

Enters the Global Configuration mode.

Step 2 **l2vpn**

Example:

```
RP/0/RP0/CPU0:router(config)# l2vpn
RP/0/RP0/CPU0:router(config-l2vpn)#
```

Enters L2VPN configuration mode.

Step 3 **bridge group** *bridge-group-name*

Example:

```
RP/0/RP0/CPU0:router(config-l2vpn)# bridge group csco
RP/0/RP0/CPU0:router(config-l2vpn-bg)#
```

Creates a bridge group so that it can contain bridge domains and then assigns network interfaces to the bridge domain.

Step 4 **bridge-domain** *bridge-domain-name*

Example:

```
RP/0/RP0/CPU0:router(config-l2vpn-bg)# bridge-domain abc
RP/0/RP0/CPU0:router(config-l2vpn-bg-bd)#
```

Establishes a bridge domain and enters l2vpn bridge group bridge domain configuration mode.

Step 5 **mac**

Example:

```
RP/0/RP0/CPU0:router(config-l2vpn-bg-bd)# mac
RP/0/RP0/CPU0:router(config-l2vpn-bg-bd-mac)#
```

Enters l2vpn bridge group bridge domain MAC configuration mode.

Step 6 **port-down flush disable**

Example:

```
RP/0/RP0/CPU0:router(config-l2vpn-bg-bd-mac)#
port-down flush disable
```

Disables MAC flush when the bridge port becomes nonfunctional.

Step 7 Use the **commit** or **end** command.

commit - Saves the configuration changes and remains within the configuration session.

end - Prompts user to take one of these actions:

- **Yes** - Saves configuration changes and exits the configuration session.
- **No** - Exits the configuration session without committing the configuration changes.
- **Cancel** - Remains in the configuration mode, without committing the configuration changes.

Configuring VPLS with BGP Autodiscovery and Signaling

Perform this task to configure BGP-based autodiscovery and signaling.

SUMMARY STEPS

1. **configure**
2. **l2vpn**
3. **bridge group** *bridge group name*
4. **bridge-domain** *bridge-domain name*
5. **vfi** { *vfi-name* }
6. **vpn-id** *vpn-id*

7. **autodiscovery bgp**
8. **rd** { *as-number:nn* | *ip-address:nn* | **auto** }
9. **route-target** { *as-number:nn* | *ip-address:nn* | **export** | **import** }
10. **route-target import** { *as-number:nn* | *ip-address:nn* }
11. **route-target export** { *as-number:nn* | *ip-address:nn* }
12. **signaling-protocol bgp**
13. **ve-id** { *number* }
14. **ve-range** { *number* }
15. Use the **commit** or **end** command.

DETAILED STEPS

Step 1 **configure**

Example:

```
RP/0/RP0/CPU0:router# configure
```

Enters the Global Configuration mode.

Step 2 **l2vpn**

Example:

```
RP/0/RP0/CPU0:router(config)# l2vpn
```

Enters L2VPN configuration mode.

Step 3 **bridge group** *bridge group name*

Example:

```
RP/0/RP0/CPU0:router(config-l2vpn)# bridge group metroA
```

Enters configuration mode for the named bridge group.

Step 4 **bridge-domain** *bridge-domain name*

Example:

```
RP/0/RP0/CPU0:router(config-l2vpn-bg)# bridge-domain east
```

Enters configuration mode for the named bridge domain.

Step 5 **vfi** { *vfi-name* }

Example:

```
RP/0/RP0/CPU0:router(config-l2vpn-bg-bd)# vfi vfi-east
```

Enters virtual forwarding instance (VFI) configuration mode.

Step 6 `vpn-id vpn-id`**Example:**

```
RP/0/RP0/CPU0:router(config-l2vpn-bg-bd-vfi)# vpn-id 100
```

Specifies the identifier for the VPLS service. The VPN ID has to be globally unique within a PE router. i.e., the same VPN ID cannot exist in multiple VFIs on the same PE router. In addition, a VFI can have only one VPN ID.

Step 7 `autodiscovery bgp`**Example:**

```
RP/0/RP0/CPU0:router(config-l2vpn-bg-bd-vfi)# autodiscovery bgp
```

Enters BGP autodiscovery configuration mode where all BGP autodiscovery parameters are configured.

This command is not provisioned to BGP until at least the VPN ID and the signaling protocol is configured.

Step 8 `rd { as-number:nn | ip-address:nn | auto }`**Example:**

```
RP/0/RP0/CPU0:router(config-l2vpn-bg-bd-vfi-ad)# rd auto
```

Specifies the route distinguisher (RD) under the VFI.

The RD is used in the BGP NLRI to identify VFI. Only one RD can be configured per VFI, and except for **rd auto** the same RD cannot be configured in multiple VFIs on the same PE.

When **rd auto** is configured, the RD value is as follows: {BGP Router ID}:{16 bits auto-generated unique index}.

Step 9 `route-target { as-number:nn | ip-address:nn | export | import }`**Example:**

```
RP/0/RP0/CPU0:router(config-l2vpn-bg-bd-vfi-ad)# route-target 500:99
```

Specifies the route target (RT) for the VFI.

At least one import and one export route targets (or just one route target with both roles) need to be configured in each PE in order to establish BGP autodiscovery between PEs.

If no export or import keyword is specified, it means that the RT is both import and export. A VFI can have multiple export or import RTs. However, the same RT is not allowed in multiple VFIs in the same PE.

Step 10 `route-target import { as-number:nn | ip-address:nn }`**Example:**

```
RP/0/RP0/CPU0:router(config-l2vpn-bg-bd-vfi-ad)# route-target import 200:20
```

Specifies the import route target for the VFI.

The PE compares import route target with the RT in the received NLRI: the RT in the received NLRI must match the import RT to determine that the RTs belong to the same VPLS service.

Step 11 **route-target export** { *as-number:nn* | *ip-address:nn* }

Example:

```
RP/0/RP0/CPU0:router(config-l2vpn-bg-bd-vfi-ad)# route-target export 100:10
```

Specifies the export route target for the VFI.

Export route target is the RT that is going to be in the NLRI advertised to other PEs.

Step 12 **signaling-protocol bgp**

Example:

```
RP/0/RP0/CPU0:router(config-l2vpn-bg-bd-vfi-ad)# signaling-protocol bgp
```

Enables BGP signaling, and enters the BGP signaling configuration submenu where BGP signaling parameters are configured.

This command is not provisioned to BGP until VE ID and VE ID range is configured.

Step 13 **ve-id** { *number* }

Example:

```
RP/0/RP0/CPU0:router(config-l2vpn-bg-bd-vfi-ad-sig)# ve-id 10
```

Specifies the local PE identifier for the VFI for VPLS configuration.

The VE ID identifies a VFI within a VPLS service. This means that VFIs in the same VPLS service cannot share the same VE ID. The scope of the VE ID is only within a bridge domain. Therefore, VFIs in different bridge domains within a PE can use the same VE ID.

Step 14 **ve-range** { *number* }

Example:

```
RP/0/RP0/CPU0:router(config-l2vpn-bg-bd-vfi-ad-sig)# ve-range 40
```

Overrides the minimum size of VPLS edge (VE) blocks.

The default minimum size is 10. Any configured VE range must be higher than 10.

Step 15 Use the **commit** or **end** command.

commit - Saves the configuration changes and remains within the configuration session.

end - Prompts user to take one of these actions:

- **Yes** - Saves configuration changes and exits the configuration session.
- **No** - Exits the configuration session without committing the configuration changes.
- **Cancel** - Remains in the configuration mode, without committing the configuration changes.

Configuring VPLS with BGP Autodiscovery and LDP Signaling

Perform this task to configure BGP-based Autodiscovery and signaling:

SUMMARY STEPS

1. **configure**
2. **l2vpn**
3. **router-id** *ip-address*
4. **bridge group** *bridge-group-name*
5. **bridge-domain** *bridge-domain-name*
6. **vfi** {*vfi-name*}
7. **autodiscovery bgp**
8. **vpn-id** *vpn-id*
9. **rd** {*as-number:nn* | *ip-address:nn* | **auto**}
10. **route-target** {*as-number:nn* | *ip-address:nn* | **export** | **import** }
11. **route-target import** {*as-number:nn* | *ip-address:nn*}
12. **route-target export** {*as-number:nn* | *ip-address:nn*}
13. **signaling-protocol ldp**
14. **vpls-id** {*as-number:nn* | *ip-address:nn*}
15. Use the **commit** or **end** command.

DETAILED STEPS

Step 1 **configure**

Example:

```
RP/0/RSP0/CPU0:router# configure
```

Enters the Global Configuration mode.

Step 2 **l2vpn**

Example:

```
RP/0/RP0/CPU0:router(config)# l2vpn
```

Enters L2VPN configuration mode.

Step 3 **router-id** *ip-address*

Example:

```
RP/0/RP0/CPU0:router(config-l2vpn)# router-id 10.0.0.1
```

Specifies a unique Layer 2 (L2) router ID for the provider edge (PE) router.

The router ID must be configured for LDP signaling, and is used as the L2 router ID in the BGP NLRI, SAII (local L2 Router ID) and TAII (remote L2 Router ID). Any arbitrary value in the IPv4 address format is acceptable.

Note Each PE must have a unique L2 router ID. This CLI is optional, as a PE automatically generates a L2 router ID using the LDP router ID.

Step 4 **bridge group** *bridge-group-name*

Example:

```
RP/0/RP0/CPU0:router(config-l2vpn)# bridge group metroA
```

Enters configuration mode for the named bridge group.

Step 5 **bridge-domain** *bridge-domain-name*

Example:

```
RP/0/RP0/CPU0:router(config-l2vpn-bg)# bridge-domain east
```

Enters configuration mode for the named bridge domain.

Step 6 **vfi** {*vfi-name*}

Example:

```
RP/0/RP0/CPU0:router(config-l2vpn-bg-bd)# vfi vfi-east
```

Enters virtual forwarding instance (VFI) configuration mode.

Step 7 **autodiscovery bgp**

Example:

```
RP/0/RP0/CPU0:router(config-l2vpn-bg-bd-vfi)# autodiscovery bgp
```

Enters BGP autodiscovery configuration mode where all BGP autodiscovery parameters are configured.

This command is not provisioned to BGP until at least the VPN ID and the signaling protocol is configured.

Step 8 **vpn-id** *vpn-id*

Example:

```
RP/0/RP0/CPU0:router(config-l2vpn-bg-bd-vfi)# vpn-id 100
```

Specifies the identifier for the VPLS service. The VPN ID has to be globally unique within a PE router. i.e., the same VPN ID cannot exist in multiple VFIs on the same PE router. In addition, a VFI can have only one VPN ID.

Step 9 **rd** {*as-number:nn* | *ip-address:nn* | **auto**}

Example:

```
RP/0/RP0/CPU0:router(config-l2vpn-bg-bd-vfi-ad)# rd auto
```

Specifies the route distinguisher (RD) under the VFI.

The RD is used in the BGP NLRI to identify VFI. Only one RD can be configured per VFI, and except for **rd auto** the same RD cannot be configured in multiple VFIs on the same PE.

When **rd auto** is configured, the RD value is as follows: {BGP Router ID}:{16 bits auto-generated unique index}.

Step 10 **route-target** {*as-number:nn* | *ip-address:nn* | **export** | **import** }

Example:

```
RP/0/RP0/CPU0:router (config-l2vpn-bg-bd-vfi-ad) # route-target 500:99
```

Specifies the route target (RT) for the VFI.

At least one import and one export route targets (or just one route target with both roles) need to be configured in each PE in order to establish BGP autodiscovery between PEs.

If no export or import keyword is specified, it means that the RT is both import and export. A VFI can have multiple export or import RTs. However, the same RT is not allowed in multiple VFIs in the same PE.

Step 11 **route-target import** {*as-number:nn* | *ip-address:nn*}

Example:

```
RP/0/RP0/CPU0:router (config-l2vpn-bg-bd-vfi-ad) # route-target import 200:20
```

Specifies the import route target for the VFI.

The PE compares the import route target with the RT in the received NLRI: the RT in the received NLRI must match the import RT to determine that the RTs belong to the same VPLS service.

Step 12 **route-target export** {*as-number:nn* | *ip-address:nn*}

Example:

```
RP/0/RP0/CPU0:router (config-l2vpn-bg-bd-vfi-ad) # route-target export 100:10
```

Specifies the export route target for the VFI.

Export route target is the RT that is going to be in the NLRI advertised to other PEs.

Step 13 **signaling-protocol ldp**

Example:

```
RP/0/RP0/CPU0:router (config-l2vpn-bg-bd-vfi-ad) # signaling-protocol ldp
```

Enables LDP signaling.

Step 14 **vpls-id** {*as-number:nn* | *ip-address:nn*}

Example:

```
RP/0/RP0/CPU0:router (config-l2vpn-bg-bd-vfi-ad-sig) # vpls-id 10:20
```

Specifies VPLS ID which identifies the VPLS domain during signaling.

This command is optional in all PEs that are in the same Autonomous System (share the same ASN) because a default VPLS ID is automatically generated using BGP's ASN and the configured VPN ID (i.e., the default VPLS ID equals ASN:VPN-ID). If an ASN of 4 bytes is used, the lower two bytes of the ASN are used to build the VPLS ID. In case of InterAS, the VPLS ID must be explicitly configured. Only one VPLS ID can be configured per VFI, and the same VPLS ID cannot be used for multiple VFIs.

Step 15 Use the **commit** or **end** command.

commit - Saves the configuration changes and remains within the configuration session.

end - Prompts user to take one of these actions:

- **Yes** - Saves configuration changes and exits the configuration session.
- **No** - Exits the configuration session without committing the configuration changes.
- **Cancel** - Remains in the configuration mode, without committing the configuration changes.

Configuring Pseudowire Headend

The PWHE is created by configuring interface pw-ether or pw-iw. For the PWHE to be functional, the xconnect has to be configured completely. Configuring other layer 3 (L3) parameters, such as VRF and IP addresses, are optional for the PWHE to be functional. However, the L3 features are required for the layer 3 services to be operational; that is, for PW L3 termination.

This section describes these topics:

PWHE Configuration Restrictions

These configuration restrictions are applicable for PWHE:

- Up to 4096 PWHE interfaces (a combination of pw-ether and pw-iw).
- Up to eight interface lists per peer.
- Up to eight L3 links per interface list.
- VLAN ID (tag-impose) can be configured only in xconnects which have pw-ether interfaces.
- VLAN ID (tag-impose) can only be configured under VC type 4 pw-ether interfaces.
- Interface lists can be configured on CRS only.
- Interface lists can accept POS, GigabitEthernet, TenGigabitEthernet, SRP, Bundle Ethernet and Bundle POS; other interfaces are rejected.
- No support for features such as pseudowire redundancy, preferred path, local switching or L2TP for xconnects configured with PWHE.
- Ethernet and VLAN transport modes are not allowed for pw-iw xconnects.
- Address family, Cisco Discovery Protocol (CDP) and MPLS configurations are not allowed on PWHE interfaces.
- IPv6 configuration is not allowed under pw-iw interfaces.

Configuring PWHE Interfaces

Perform this task to configure PWHE interfaces, that is, to attach the generic interface list with a PWHE interfaces.

SUMMARY STEPS

1. **configure**
2. **interface pw-ether** *id*
3. **attach generic-interface-list** *interface_list_name*
4. Use the **commit** or **end** command.

DETAILED STEPS

Step 1 **configure**

Example:

```
RP/0/RP0/CPU0:router# configure
```

Enters the Global Configuration mode.

Step 2 **interface pw-ether** *id*

Example:

```
RP/0/RP0/CPU0:router(config)# interface pw-ether <id>
```

Configures the PWHE interface and enters the interface configuration mode.

Step 3 **attach generic-interface-list** *interface_list_name*

Example:

```
RP/0/RP0/CPU0:router(config-if)# attach generic-interface-list interfacelist1
```

Attaches the generic interface list to the PW-Ether or PW-IW interface . To remove the generic interface list from the PW-Ether or PW-IW interface, use the **no** form of the command, that is, **no generic-interface-list** *list-name*

Step 4 Use the **commit** or **end** command.

commit - Saves the configuration changes and remains within the configuration session.

end - Prompts user to take one of these actions:

- **Yes** - Saves configuration changes and exits the configuration session.
- **No** - Exits the configuration session without committing the configuration changes.
- **Cancel** - Remains in the configuration mode, without committing the configuration changes.

Restrictions for Configuring PWHE Interfaces

These are the restrictions for configuring PWHE interfaces:

- Neighbor and pw-ID pair must be unique in L2VPN.

- pw-ether interfaces have to be VC type 4 or 5.
- pw-iw interfaces cannot have IPv6 address because IPv6 is not supported on pw-iw (VC type 11). The VC type is set to type 11 if AC is pw-iw even when interworking ipv4 is not configured.
- The VLAN ID is allowed only if VC type is 4.
- MPLS protocols (MPLS-TE, LDP, RSVP) cannot be configured on PW-HE.
- No interface list configuration is accepted on non-PWHE platforms.

Configuring PWHE Interface Parameters

Perform this task to configure PWHE interface parameters.

SUMMARY STEPS

1. **configure**
2. **interface pw-ether** *id*
3. **attach generic-interface-list** *interface_list_name*
4. **l2overhead** *bytes*
5. **load-interval** *seconds*
6. **dampening** *decay-life*
7. **logging events link-status**
8. **mac-address** *MAC address*
9. **mtu** *interface_MTU*
10. Use the **commit** or **end** command.

DETAILED STEPS

Step 1 **configure**

Example:

```
RP/0/RP0/CPU0:router# configure
```

Enters the Global Configuration mode.

Step 2 **interface pw-ether** *id*

Example:

```
RP/0/RP0/CPU0:router(config)# interface pw-ether <id>
or
RP/0/RP0/CPU0:router(config)# interface pw-iw <id>
```

(**interface pw-ether** *id*) Configures the PWHE interface and enters the interface configuration mode.

(**interface pw-iw** *id*) Configures the PWHE interface and enters the interface configuration mode.

Step 3 **attach generic-interface-list** *interface_list_name*

Example:

```
RP/0/RP0/CPU0:router(config-if)# attach generic-interface-list interfacelist1
```

Attaches the generic interface list to the PW-Ether or PW-IW interface.

Step 4 **l2overhead** *bytes*

Example:

```
RP/0/RP0/CPU0:router(config-if)# l2overhead 20
```

Sets layer 2 overhead size.

Step 5 **load-interval** *seconds*

Example:

```
RP/0/RP0/CPU0:router(config-if)# load-interval 90
```

Specifies interval, in seconds, for load calculation for an interface.

The interval:

- Can be set to 0 [0 disables load calculation]
- If not 0, must be specified in multiples of 30 between 30 and 600.

Step 6 **dampening** *decay-life*

Example:

```
RP/0/RP0/CPU0:router(config-if)# dampening 10
```

Configures state dampening on the given interface (in minutes).

Step 7 **logging events link-status**

Example:

```
RP/0/RP0/CPU0:router(config-if)# logging events link-status
```

Configures per interface logging.

Step 8 **mac-address** *MAC address*

Example:

```
RP/0/RP0/CPU0:router(config-if)# mac-address aaaa.bbbb.cccc
```

Sets the MAC address (xxxx.xxxx.xxxx) on an interface.

Step 9 **mtu** *interface_MTU*

Example:

```
RP/0/RP0/CPU0:router(config-if)# mtu 128
```

Sets the MTU on an interface.

Step 10 Use the **commit** or **end** command.

commit - Saves the configuration changes and remains within the configuration session.

end - Prompts user to take one of these actions:

- **Yes** - Saves configuration changes and exits the configuration session.
- **No** - Exits the configuration session without committing the configuration changes.
- **Cancel** - Remains in the configuration mode, without committing the configuration changes.

Configuring PWHE Crossconnect

Perform this task to configure PWHE crossconnects.

SUMMARY STEPS

1. **configure**
2. **l2vpn**
3. **xconnect group** *group-name*
4. **p2p** *xconnect-name*
5. **interface pw-ether** *id*
6. **neighbor A.B.C.D pw-id** *value*
7. **pw-class** *class-name*
8. Use the **commit** or **end** command.

DETAILED STEPS

Step 1 **configure**

Example:

```
RP/0/RP0/CPU0:router# configure
```

Enters the Global Configuration mode.

Step 2 **l2vpn**

Example:

```
RP/0/RP0/CPU0:router(config)# l2vpn
```

Enters Layer 2 VPN configuration mode.

Step 3 **xconnect group** *group-name*

Example:

```
RP/0/RP0/CPU0:router (config-l2vpn)# xconnect group MS-PW1
```

Configures a cross-connect group name using a free-format 32-character string.

Step 4 **p2p** *xconnect-name*

Example:

```
RP/0/RP0/CPU0:router (config-l2vpn-xc) # p2p ms-pw1
```

Enters P2P configuration submode.

Step 5 **interface pw-ether** *id*

Example:

```
RP/0/RP0/CPU0:router(config-l2vpn-xc-p2p) # interface pw-ether 100
```

Configures the PWHE interface.

Step 6 **neighbor A.B.C.D pw-id** *value*

Example:

```
RP/0/RP0/CPU0:router(config-l2vpn-xc-p2p) # neighbor 10.165.200.25 pw-id 100
```

Configures a pseudowire for a cross-connect.

The IP address is that of the corresponding PE node.

The **pw-id** must match the **pw-id** of the PE node.

Step 7 **pw-class** *class-name*

Example:

```
RP/0/RP0/CPU0:router(config-l2vpn-xc-p2p-pw) # pw-class dynamic_mpls
```

Enters pseudowire class submode, allowing you to define a pseudowire class template.

Step 8 Use the **commit** or **end** command.

commit - Saves the configuration changes and remains within the configuration session.

end - Prompts user to take one of these actions:

- **Yes** - Saves configuration changes and exits the configuration session.
- **No** - Exits the configuration session without committing the configuration changes.
- **Cancel** - Remains in the configuration mode, without committing the configuration changes.

Enabling Pseudowire Grouping

Perform this task to enable pseudowire grouping.

SUMMARY STEPS

1. **configure**
2. **l2vpn**
3. **pw-grouping**
4. Use the **commit** or **end** command.

DETAILED STEPS

Step 1 **configure**

Example:

```
RP/0/RP0/CPU0:router# configure
```

Enters the Global Configuration mode.

Step 2 **l2vpn**

Example:

```
RP/0/RP0/CPU0:router(config)# l2vpn  
RP/0/RP0/CPU0:router(config-l2vpn)#
```

Enters L2VPN configuration mode.

Step 3 **pw-grouping**

Example:

```
RP/0/RP0/CPU0:router(config-l2vpn)# pw-grouping
```

Enables pseudowire grouping

Step 4 Use the **commit** or **end** command.

commit - Saves the configuration changes and remains within the configuration session.

end - Prompts user to take one of these actions:

- **Yes** - Saves configuration changes and exits the configuration session.
 - **No** - Exits the configuration session without committing the configuration changes.
 - **Cancel** - Remains in the configuration mode, without committing the configuration changes.
-

Configuration Examples for Multipoint Layer 2 Services

This section includes these configuration examples:

Multipoint Layer 2 Services Configuration for Provider Edge-to-Provider Edge: Example

These configuration examples show how to create a Layer 2 VFI with a full-mesh of participating Multipoint Layer 2 Services provider edge (PE) nodes.

This configuration example shows how to configure PE 1:

```
configure  
l2vpn  
  bridge group 1  
    bridge-domain PE1-VPLS-A  
    interface TenGigE0/0/0/0
```

```

vfi 1
  neighbor 172.16.0.1 pw-id 1
  neighbor 192.168.0.1 pw-id 1
  !
!
interface loopback 0
  ipv4 address 10.0.0.1 255.0.0.0

```

This configuration example shows how to configure PE 2:

```

configure
l2vpn
  bridge group 1
  bridge-domain PE2-VPLS-A
  interface TenGigE0/0/0/1

  vfi 1
  neighbor 10.0.0.1 pw-id 1
  neighbor 192.168.0.1 pw-id 1
  !
!
interface loopback 0
  ipv4 address 172.16.0.1 255.240.0.0

```

This configuration example shows how to configure PE 3:

```

configure
l2vpn
  bridge group 1
  bridge-domain PE3-VPLS-A
  interface TenGigE0/0/0/2
  vfi 1
  neighbor 10.0.0.1 pw-id 1
  neighbor 172.16.0.1 pw-id 1
  !
!
interface loopback 0
  ipv4 address 192.168.0.1 255.255.0.0

```

Multipoint Layer 2 Services Configuration for Provider Edge-to-Customer Edge: Example

This configuration shows how to configure Multipoint Layer 2 Services for a PE-to-CE nodes:

```

configure
interface TenGigE0/0/0/0
  l2transport---AC interface
  exit
  no ipv4 address
  no ipv4 directed-broadcast
  negotiation auto
  no cdp enable
end

```

Configuring Backup Disable Delay: Example

The following example shows how a backup delay is configured for point-to-point PW where the backup disable delay is 50 seconds:

```

l2vpn
pw-class class_1
backup disable delay 20
exit
xconnect group_A
p2p rtrX_to_rtrY
neighbor 10.0.0.1 pw-id 2
pw-class class_1
backup neighbor 172.16.0.1 pw- id 5
commit

```

The following example shows how a backup delay is configured for point-to-point PW where the backup disable delay is never:

```

l2vpn
pw-class class_1
backup disable never
exit
xconnect group_A
p2p rtrX_to_rtrY
    neighbor 10.0.0.1 pw-id 2
pw-class class_1
    backup neighbor 172.16.0.1 pw-id 5
commit

```

Disabling MAC Flush: Examples

You can disable the MAC flush at these levels:

- bridge domain
- bridge port (attachment circuit (AC))
- access pseudowire (PW)

The following example shows how to disable the MAC flush at the bridge domain level:

```

configure
l2vpn
    bridge-group group1
    bridge-domain domain1
    mac
    port-down flush disable
end

```

The following example shows how to disable the MAC flush at the bridge port level:

```

configure
l2vpn
    bridge-group group1
    bridge-domain domain1
    interface TenGigE 0/0/0/0
    mac
    port-down flush disable
end

```

H-VPLS Configuration: Examples

This example shows how to configure hierarchical VPLS (H-VPLS). All examples in this section are based on the following topology where N-PE1 is the H-VPLS Node:

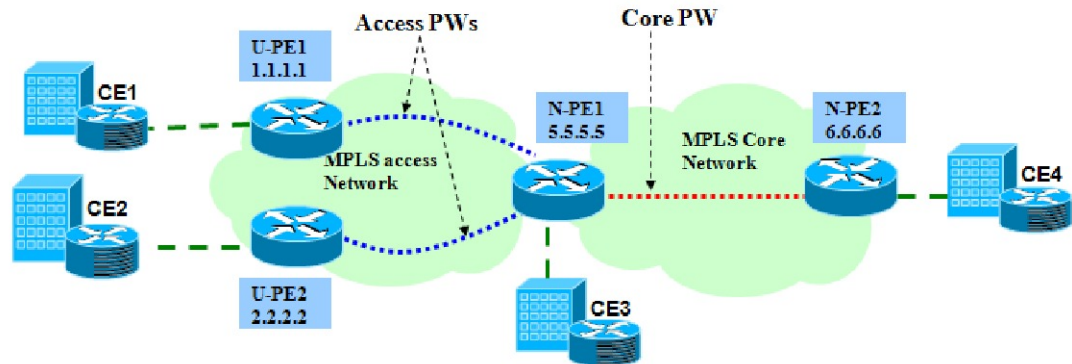

331417

VPLS with QinQ or QinAny: Example

Global Interface Configuration at N-PE1:

```
interface GigabitEthernet0/0/0/0
dot1q tunneling ethertype 0x9200
!
interface GigabitEthernet0/0/0/1
dot1q tunneling ethertype 0x9100
!
interface GigabitEthernet0/0/0/0.1 l2transport
encapsulation dot1q 20 second-dot1q 21
!
interface GigabitEthernet0/0/0/1.1 l2transport
encapsulation dot1q 10 second-dot1q any
```

L2VPN Configuration at N-PE1:

```
l2vpn
bridge group g1
bridge-domain d1
interface GigabitEthernet0/0/0/0.1
!
interface GigabitEthernet0/0/0/1.1
!
vfi core-pws
neighbor 6.6.6.6 pw-id 10
```

Global Interface Configuration at N-PE2:

```
interface GigabitEthernet0/6/0/0
dot1q tunneling ethertype 0x9200
!
interface GigabitEthernet0/6/0/1
dot1q tunneling ethertype 0x9100
```



```

!
interface GigabitEthernet0/6/0/0.1 l2transport
encapsulation dot1q 10 second-dot1q 20
!
interface GigabitEthernet0/6/0/1.1 l2transport
encapsulation dot1q 1 second-dot1q 2

```

L2VPN Configuration at N-PE2:

```

l2vpn
bridge group g1
bridge-domain dl
interface GigabitEthernet0/6/0/0.1
!
interface GigabitEthernet0/6/0/1.1
!
vfi core-pws
neighbor 5.5.5.5 pw-id 10

```

H-VPLS with Access-PWs: Example

Router Configuration at U-PE1:

```

l2vpn
pw-class vpls
encapsulation mpls
transport-mode ethernet
!
xconnect group g1
p2p p1
interface GigabitEthernet0/1/1/0.1 --> Local AC
neighbor 192.168.0.1 pw-id 100 --> Access PW to N-PE1
pw-class vpls
interface GigabitEthernet0/1/1/0.1 l2transport
encapsulation dot1q 1

```

Router Configuration at U-PE2:

```

l2vpn
pw-class vpls
encapsulation mpls
transport-mode ethernet
mac-withdraw
!
xconnect group g1
p2p p1
interface GigabitEthernet0/2/5/0.1 --> Local AC
neighbor 192.168.0.1 pw-id 100 --> Access PW to N-PE1
pw-class vpls
interface GigabitEthernet0/2/5/0.1 l2transport
encapsulation dot1q 1

```

Router Configuration at N-PE1:

```

l2vpn
bridge group g1
bridge-domain dl
interface GigabitEthernet0/1/4/0.1 ? Local AC

```

```

neighbor 10.0.0.1 pw-id 100 --> Access PW to U-PE1
neighbor 172.16.0.1 pw-id 100 --> Access PW to U-PE2
!
vfi core1
  neighbor 192.168.0.2 pw-id 100 --> Core PW to N-PE2
interface GigabitEthernet0/1/4/0.1 l2transport
encapsulation dot1q 1

```

Router Configuration at N-PE2:

```

l2vpn
bridge group g1
  bridge-domain d1
  interface GigabitEthernet0/2/1/0.1 --> Local AC
  vfi core1
    neighbor 192.168.0.1 pw-id 100 --> Core PW to N-PE1
interface GigabitEthernet0/2/1/0.1 l2transport
encapsulation dot1q 1

```

Configuring VPLS with BGP Autodiscovery and Signaling: Example

This section contains these configuration examples for configuring the BGP autodiscovery and signaling feature:

LDP and BGP Configuration

The following figure illustrates an example of LDP and BGP configuration.

Figure 20: LDP and BGP Configuration

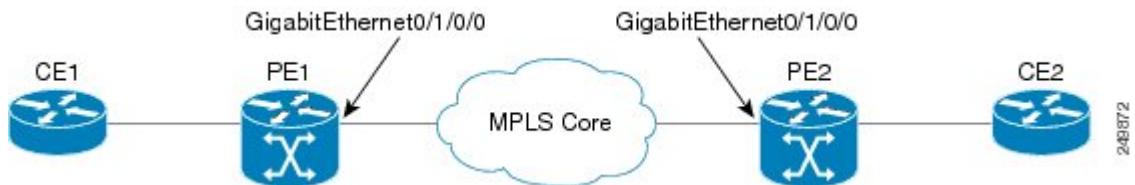

Configuration at PE1:

```

interface Loopback0
  ipv4 address 10.0.0.100 255.0.0.0
!
interface Loopback1
  ipv4 address 10.0.0.1 255.0.0.0
!
mpls ldp
  router-id 10.0.0.10
  interface GigabitEthernet0/1/0/0
!
router bgp 120
  address-family l2vpn vpls-vpws
!
  neighbor 172.16.0.1
  remote-as 120
  update-source Loopback1
  address-family l2vpn vpls-vpws
  signaling bgp disable

```

Configuration at PE2:

```

interface Loopback0
  ipv4 address 172.16.0.10 255.255.255.255
!
interface Loopback1
  ipv4 address 172.16.0.1 255.255.255.255
!
mpls ldp
  router-id 172.16.0.100
  interface GigabitEthernet0/1/0/0
!
router bgp 120
  address-family l2vpn vpls-vpws
!
  neighbor 10.0.0.11
  remote-as 120
  update-source Loopback1
  address-family l2vpn vpls-vpws

```

Minimum L2VPN Configuration for BGP Autodiscovery with BGP Signaling

This example illustrates the minimum L2VPN configuration required for BGP Autodiscovery with BGP Signaling, where any parameter that has a default value is not configured.

```

(config)# l2vpn
(config-l2vpn)# bridge group {bridge group name}
(config-l2vpn-bg)# bridge-domain {bridge domain name}
(config-l2vpn-bg-bd)# vfi {vfi name}
(config-l2vpn-bg-bd-vfi)# autodiscovery bgp
(config-l2vpn-bg-bd-vfi-ad)# vpn-id 10
(config-l2vpn-bg-bd-vfi-ad)# rd auto
(config-l2vpn-bg-bd-vfi-ad)# route-target 10.0.0.1:100
(config-l2vpn-bg-bd-vfi-ad-sig)# signaling-protocol bgp
(config-l2vpn-bg-bd-vfi-ad-sig)# ve-id 1
(config-l2vpn-bg-bd-vfi-ad-sig)# commit

```

VPLS with BGP Autodiscovery and BGP Signaling

The following figure illustrates an example of configuring VPLS with BGP autodiscovery (AD) and BGP Signaling.

Figure 21: VPLS with BGP autodiscovery and BGP signaling

**Configuration at PE1:**

```

l2vpn
  bridge group gr1
  bridge-domain bd1
  interface GigabitEthernet0/1/0/1.1
  vfi vf1
  ! AD independent VFI attributes

```

```

vpn-id 100
! Auto-discovery attributes
autodiscovery bgp
rd auto
route-target 2.2.2.2:100
! Signaling attributes
signaling-protocol bgp
ve-id 3

```

Configuration at PE2:

```

l2vpn
bridge group gr1
bridge-domain bd1
interface GigabitEthernet0/1/0/2.1
vfi vf1
! AD independent VFI attributes
vpn-id 100
! Auto-discovery attributes
autodiscovery bgp
rd auto
route-target 2.2.2.2:100
! Signaling attributes
signaling-protocol bgp
ve-id 5

```

This is an example of NLRI for VPLS with BGP AD and signaling:



Discovery Attributes

NLRI sent at PE1:

```

Length = 19
Router Distinguisher = 3.3.3.3:32770
VE ID = 3
VE Block Offset = 1
VE Block Size = 10
Label Base = 16015

```

NLRI sent at PE2:

```

Length = 19
Router Distinguisher = 1.1.1.1:32775
VE ID = 5
VE Block Offset = 1
VE Block Size = 10
Label Base = 16120

```

Minimum Configuration for BGP Autodiscovery with LDP Signaling

This example illustrates the minimum L2VPN configuration required for BGP Autodiscovery with LDP Signaling, where any parameter that has a default value is not configured.

```
(config)# l2vpn
(config-l2vpn)# bridge group {bridge group name}
(config-l2vpn-bg)# bridge-domain {bridge domain name}
(config-l2vpn-bg-bd)# vfi {vfi name}
(config-l2vpn-bg-bd-vfi)# autodiscovery bgp
(config-l2vpn-bg-bd-vfi-ad)# vpn-id 10
(config-l2vpn-bg-bd-vfi-ad)# rd auto
(config-l2vpn-bg-bd-vfi-ad)# route-target 1.1.1.1:100
(config-l2vpn-bg-bd-vfi-ad)# commit
```

VPLS with BGP Autodiscovery and LDP Signaling

The following figure illustrates an example of configuring VPLS with BGP autodiscovery (AD) and LDP Signaling.

Figure 22: VPLS with BGP autodiscovery and LDP signaling

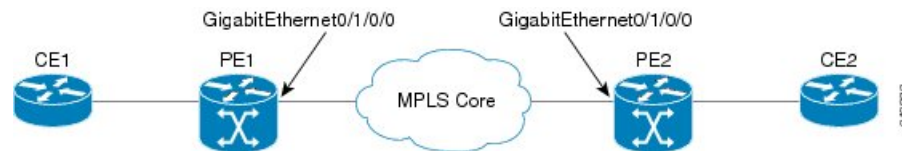

Configuration at PE1:

```
l2vpn
router-id 10.10.10.10
bridge group bg1
bridge-domain bd1
vfi vf1
vpn-id 100
autodiscovery bgp
rd 1:100
router-target 12:12
```

Configuration at PE2:

```
l2vpn
router-id 20.20.20.20
bridge group bg1
bridge-domain bd1
vfi vf1
vpn-id 100
autodiscovery bgp
rd 2:200
router-target 12:12
signaling-protocol ldp
vpls-id 120:100
```

Discovery and Signaling Attributes

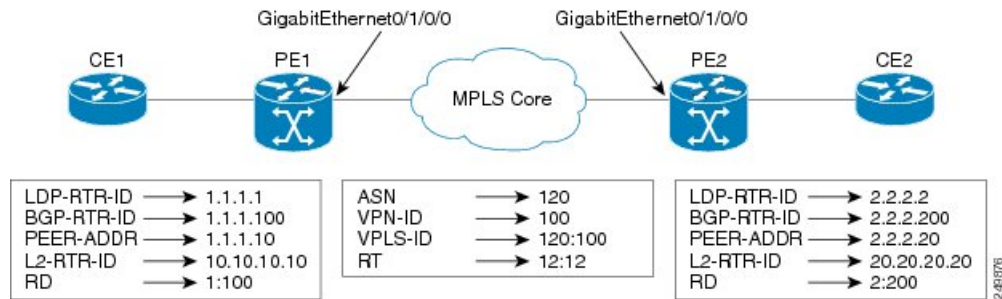

Configuration at PE1:

```
LDP Router ID - 10.0.0.1
BGP Router ID - 10.0.0.100
Peer Address - 10.0.0.10
L2VPN Router ID - 10.10.10.10
Route Distinguisher - 1:100
```

Common Configuration between PE1 and PE2:

```
ASN - 120
VPN ID - 100
VPLS ID - 120:100
Route Target - 12:12
```

Configuration at PE2:

```
LDP Router ID - 172.16.0.1
BGP Router ID - 172.16.0.100
Peer Address - 172.16.0.10
L2VPN Router ID - 192.168.0.1
Route Distinguisher - 2:200
```

Discovery Attributes

NLRI sent at PE1:

```
Source Address - 10.0.0.10
Destination Address - 172.16.0.10
Length - 14
Route Distinguisher - 1:100
L2VPN Router ID - 10.10.10.10
VPLS ID - 120:100
Route Target - 12:12
```

NLRI sent at PE2:

```
Source Address - 172.16.0.10
Destination Address - 10.0.0.10
Length - 14
Route Distinguisher - 2:200
L2VPN Router ID - 192.168.0.1
```

VPLS ID - 120:100
Route Target - 12:12

Configuring Pseudowire Headend: Example

This section provides an example of pseudowire headend configuration.

Figure 23: PWHE Configuration Example

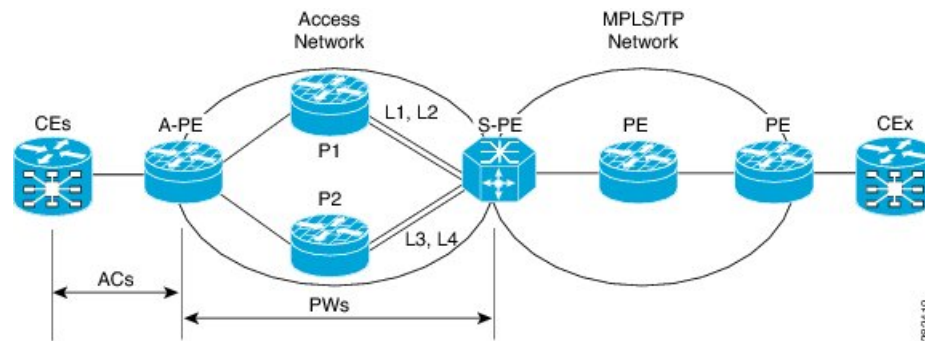

Consider the topology in the above figure.

1. There are many customer edge routers (CEs) connected to a A-PE (each CE is connected using 1 link).
2. There are two P routers between A-PE and S-PE in the access network.
3. S-PE is connected by two links to P1—links L1 and L2 (on two separate linecards on P1 and S-PE); for example, Gig0/1/0/0 and Gig0/2/0/0 respectively.
4. S-PE is connected by two links to P2—L3 and L4 (on two separate linecards on P2 and S-PE); for example, Gig0/1/0/1 and Gig0/2/0/1 respectively.
5. For each CE-APE link, a xconnect (AC-PW) is configured on the A-PE. The PWs are connected to S-PE; some PWs are connected to [L1 (Gig0/1/0/0), L4 (Gig0/2/0/1)] and others through [L2 (Gig0/1/0/1), L3 (Gig0/2/0/0)].
6. A-PE uses router-id 100.100.100.100 for routing and PW signaling.
7. The two router-ids on S-PE used for PW signaling are 111.111.111.111 and 112.112.112.112 (for Rx pin-down). 110.110.110.110 is the router-id assigned for routing.

CE Configuration

Consider two CEs connected using GigabitEthernet0/3/0/0 (CE1 and A-PE) and GigabitEthernet0/3/0/1 (CE2 and A-PE).

CE1

```
interface Gig0/3/0/0
  ipv4 address 10.0.0.1/8
  router static
  address-family ipv4 unicast
    110.110.110.110 Gig0/3/0/0
    A.B.C.D/N 110.110.110.110
```

CE2

```
interface Gig0/3/0/1
  ipv4 address 10.1.2.1/24
router static
  address-family ipv4 unicast
    110.110.110.110 Gig0/3/0/1
  A.B.C.D/N 110.110.110.110
```

A-PE Configuration

At A-PE, one xconnect is configured for each CE connection. Here, CE connections are L2 links, which are in xconnects. Each xconnect has a pseudowire connected to S-PE, though connected to different neighbor addresses, depending on where the pseudowire is to be pin downed: [L1, L4] or [L2, L3].

```
interface Gig0/3/0/0
  l2transport
interface Gig0/3/0/1
  l2transport

l2vpn
  xconnect group pwhe
    p2p pwhe_spe_1
      interface Gig0/3/0/0
        neighbor 111.111.111.111 pw-id 1
    p2p pwhe_spe_2
      interface Gig0/3/0/1
        neighbor 112.112.112.112 pw-id 2
```

P Router Configuration

Static routes are required on P routers for Rx pindown on S-PE to force PWs configured with a specific address to be transported over certain links.

P1

```
router static
  address-family ipv4 unicast
    111.111.111.111 Gig0/1/0/0
    112.112.112.112 Gig0/2/0/0
```

P2

```
router static
  address-family ipv4 unicast
    111.111.111.111 Gig0/2/0/1
    112.112.112.112 Gig0/1/0/1
```

S-PE Configuration

At S-PE, two PWHE interfaces (one for each PW) is configured, and each uses a different interface list for Tx pin-down. (This must match the static configuration at P routers for Rx pin-down). Each PWHE has the PW connected to A-PE (The pw-id must match the pw-id at A-PE.)

```
generic-interface-list il1
  interface gig0/1/0/0
  interface gig0/2/0/0
generic-interface-list il2
  interface gig0/1/0/1
  interface gig0/2/0/1

interface pw-ether1
  ipv4 address 10.1.1.2/24
  attach generic-interface-list il1
interface pw-ether2
  ipv4 address 10.1.2.2/24
  attach generic-interface-list il2

l2vpn
  xconnect group pwhe
  p2p pwhe1
    interface pw-ether1
      neighbor 100.100.100.100 pw-id 1
  p2p pwhe2
    interface pw-ether2
      neighbor 100.100.100.100 pw-id 2
```

Enabling Pseudowire Grouping: Example

This example shows how to enable pseudowire grouping.

```
config
l2vpn
  pw-grouping
```



CHAPTER 5

Implementing IPv6 VPN Provider Edge Transport over MPLS

IPv6 Provider Edge or IPv6 VPN Provider Edge (6PE/VPE) uses the existing MPLS IPv4 core infrastructure for IPv6 transport. 6PE/VPE enables IPv6 sites to communicate with each other over an MPLS IPv4 core network using MPLS label switched paths (LSPs).

This feature relies heavily on multiprotocol Border Gateway Protocol (BGP) extensions in the IPv4 network configuration on the provider edge (PE) router to exchange IPv6 reachability information (in addition to an MPLS label) for each IPv6 address prefix. Edge routers are configured as dual-stack, running both IPv4 and IPv6, and use the IPv4 mapped IPv6 address for IPv6 prefix reachability exchange.

For detailed information about the commands used to configure 6PE/VPE, see the .

Feature History for Implementing 6PE/VPE Transport over MPLS

Release	Modification
Release 3.7.0	This feature was introduced. Support was added for Inter-AS 6PE.
Release 4.1.0	Support for the Open Shortest Path First version 3 (OSPFv3) IPv6 VPN Provider Edge (6VPE) feature was added.

- [Prerequisites for Implementing 6PE/VPE, on page 125](#)
- [Information About 6PE/VPE, on page 126](#)
- [How to Implement 6PE/VPE, on page 129](#)
- [Configuration Examples for 6PE/VPE, on page 137](#)

Prerequisites for Implementing 6PE/VPE

The following prerequisites are required to implement 6PE/VPE:

- You must be in a user group associated with a task group that includes the proper task IDs. The command reference guides include the task IDs required for each command.

If you suspect user group assignment is preventing you from using a command, contact your AAA administrator for assistance.

- Familiarity with MPLS and BGP4 configuration and troubleshooting.

Information About 6PE/VPE

To configure the 6PE/VPE feature, you should understand the concepts that are described in these sections:

Overview of 6PE/VPE

Multiple techniques are available to integrate IPv6 services over service provider core backbones:

- Dedicated IPv6 network running over various data link layers
- Dual-stack IPv4-IPv6 backbone
- Existing MPLS backbone leverage

These solutions are deployed on service providers' backbones when the amount of IPv6 traffic and the revenue generated are in line with the necessary investments and the agreed-upon risks. Conditions are favorable for the introduction of native IPv6 services, from the edge, in a scalable way, without any IPv6 addressing restrictions and without putting a well-controlled IPv4 backbone in jeopardy. Backbone stability is essential for service providers that have recently stabilized their IPv4 infrastructure.

Service providers running an MPLS/IPv4 infrastructure follow similar trends because several integration scenarios that offer IPv6 services on an MPLS network are possible. Cisco Systems has specially developed Cisco 6PE or IPv6 Provider Edge Router over MPLS, to meet all those requirements.

Inter-AS support for 6PE requires support of Border Gateway Protocol (BGP) to enable the address families and to allocate and distribute PE and ASBR labels.



Note Cisco IOS XR displays actual IPv4 next-hop addresses for IPv6 labeled-unicast and VPNv6 prefixes. IPv4-mapped-to-IPv6 format is not supported.

Benefits of 6PE/VPE

Service providers who currently deploy MPLS experience these benefits of Cisco 6PE/VPE:

- Minimal operational cost and risk—No impact on existing IPv4 and MPLS services.
- Provider edge routers upgrade only—A 6PE/VPE router can be an existing PE router or a new one dedicated to IPv6 traffic.
- No impact on IPv6 customer edge routers—The ISP can connect to any customer CE running Static, IGP or EGP.
- Production services ready—An ISP can delegate IPv6 prefixes.
- IPv6 introduction into an existing MPLS service—6PE/VPE routers can be added at any time.
- It is possible to switch up to OC-192 speed in the core.

IPv6 on the Provider Edge and Customer Edge Routers

Service Provider Edge Routers

6PE is particularly applicable to service providers who currently run an MPLS network. One of its advantages is that there is no need to upgrade the hardware, software, or configuration of the core network, and it eliminates the impact on the operations and the revenues generated by the existing IPv4 traffic. MPLS is used by many service providers to deliver services to customers. MPLS as a multiservice infrastructure technology is able to provide layer 3 VPN, QoS, traffic engineering, fast re-routing and integration of ATM and IP switching.

Customer Edge Routers

Using tunnels on the CE routers is the simplest way to deploy IPv6 over MPLS networks. It has no impact on the operation or infrastructure of MPLS and requires no changes to the P routers in the core or to the PE routers. However, tunnel meshing is required as the number of CEs to connect increases, and it is difficult to delegate a global IPv6 prefix for an ISP.

The following figure illustrates the network architecture using tunnels on the CE routers.

Figure 24: IPv6 Using Tunnels on the CE Routers

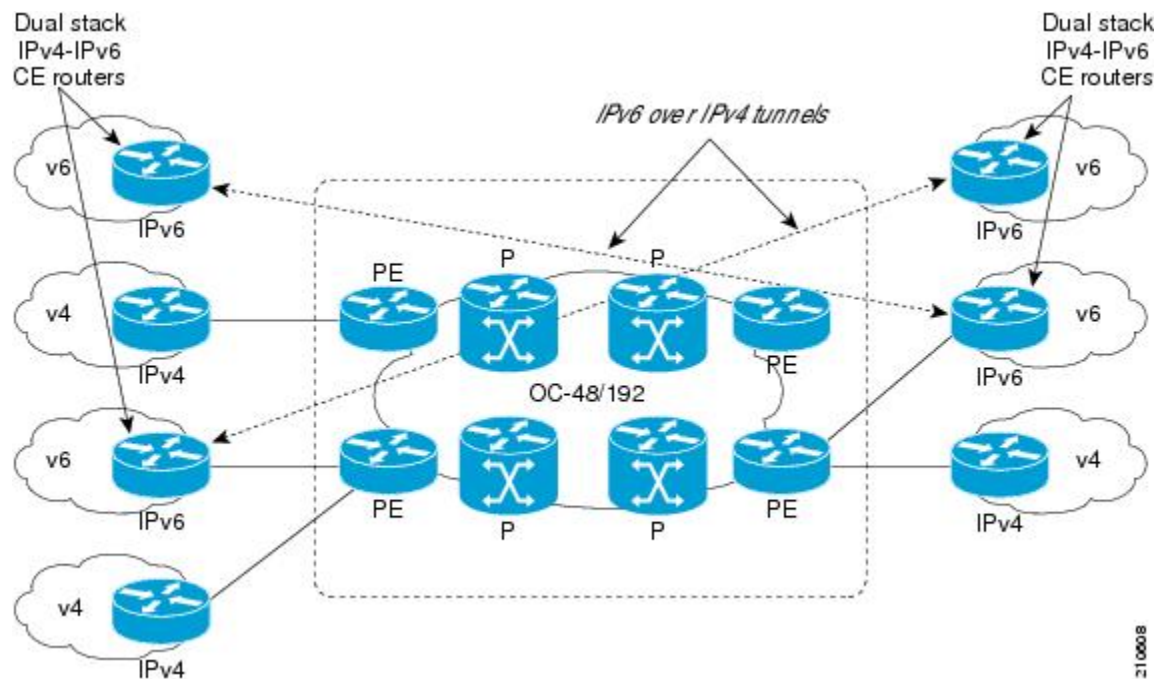

IPv6 Provider Edge Multipath

Internal and external BGP multipath for IPv6 allows the IPv6 router to load balance between several paths (for example, same neighboring autonomous system (AS) or sub-AS, or the same metric) to reach its destination. The 6PE multipath feature uses multiprotocol internal BGP (MP-IBGP) to distribute IPv6 routes over the MPLS IPv4 core network and to attach an MPLS label to each route.

When MP-IBGP multipath is enabled on the 6PE router, all labeled paths are installed in the forwarding table with MPLS information (label stack) when MPLS information is available. This functionality enables 6PE to perform load balancing.

OSPFv3 6VPE

The Open Shortest Path First version 3 (OSPFv3) IPv6 VPN Provider Edge (6VPE) feature adds VPN routing and forwarding (VRF) and provider edge-to-customer edge (PE-CE) routing support to Cisco IOS XR OSPFv3 implementation. This feature allows:

- Multiple VRF support per OSPFv3 routing process
- OSPFv3 PE-CE extensions

Multiple VRF Support

OSPFv3 supports multiple VRFs in a single routing process that allows scaling to tens and hundreds of VRFs without consuming too much route processor (RP) resources.

Multiple OSPFv3 processes can be configured on a single router. In large-scale VRF deployments, this allows partition VRF processing across multiple RPs. It is also used to isolate default routing table or high impact VRFs from the regular VRFs. It is recommended to use a single process for all the VRFs. If needed, a second OSPFv3 process must be configured for IPv6 routing.



Note The maximum of four OSPFv3 processes are supported.

OSPFv3 PE-CE Extensions

IPv6 protocol is being vastly deployed in today's customer networks. Service Providers (SPs) need to be able to offer Virtual Private Network (VPN) services to their customers for supporting IPv6 protocol, in addition to the already offered VPN services for IPv4 protocol.

In order to support IPv6, routing protocols require additional extensions for operating in the VPN environment. Extensions to OSPFv3 are required in order for OSPFv3 to operate at the PE-CE links.

VRF Lite

VRF lite feature enables VRF deployment without BGP or MPLS based backbone. In VRF lite, the PE routers are directly connected using VRF interfaces. For OSPFv3, the following needs to operate differently in the VRF lite scenario, as opposed to the deployment with BGP or MPLS backbone:

- DN bit processing—In VRF lite environment, the DN bit processing is disabled.
- ABR status—In VRF context (except default VRF), OSPFv3 router is automatically set as an ABR, regardless to its connectivity to area 0. This automatic ABR status setting is disabled in the VRF lite environment.



Note To enable VRF Lite, issue the **capability vrf-lite** command in the OSPFv3 VRF configuration submode.

How to Implement 6PE/VPE

This section includes these implementation procedures:

Configuring 6PE/VPE

This task describes how to configure 6PE/VPE on PE routers to transport the IPv6 prefixes across the IPv4 cloud.

Ensure that you configure 6PE/VPE on PE routers participating in both the IPv4 cloud and IPv6 clouds.



Note To learn routes from both clouds, you can use all routing protocols supported on Cisco IOS XR software: BGP, OSPF, IS-IS, EIGRP, RIP, and Static.

SUMMARY STEPS

1. **configure**
2. **router bgp** *as-number*
3. **neighbor** *ip-address*
4. **remote-as** *as-number*
5. **address-family ipv6** **labeled-unicast**
6. **exit**
7. **exit**
8. **address-family ipv6** **unicast**
9. **allocate-label** [**all** | **route-policy** *policy_name*]
10. Use the **commit** or **end** command.

DETAILED STEPS

Step 1 **configure**

Example:

```
RP/0/RP0/CPU0:router# configure
```

Enters the Global Configuration mode.

Step 2 **router bgp** *as-number*

Example:

```
RP/0/RP0/CPU0:router(config)# router bgp 1
```

Enters the number that identifies the autonomous system (AS) in which the router resides.

Range for 2-byte numbers is 1 to 65535. Range for 4-byte numbers is 1.0 to 65535.65535.

Step 3 `neighbor ip-address`**Example:**

```
RP/0/RP0/CPU0:router(config-bgp)# neighbor 10.0.0.1
```

Enters neighbor configuration mode for configuring Border Gateway Protocol (BGP) routing sessions.

Step 4 `remote-as as-number`**Example:**

```
RP/0/RP0/CPU0:router(config-bgp-nbr)# remote-as 100
```

Creates a neighbor and assigns a remote autonomous system number to it.

Step 5 `address-family ipv6 labeled-unicast`**Example:**

```
RP/0/RP0/CPU0:router(config-bgp-nbr)# address-family ipv6 labeled-unicast
```

Specifies IPv6 labeled-unicast address prefixes.

Note This option is also available in IPv6 neighbor configuration mode and VRF neighbor configuration mode.

Step 6 `exit`**Example:**

```
RP/0/RP0/CPU0:router(config-bgp-nbr-af)# exit
```

Exits BGP address-family submode.

Step 7 `exit`**Example:**

```
RP/0/RP0/CPU0:router(config-bgp-nbr)# exit
```

Exits BGP neighbor submode.

Step 8 `address-family ipv6 unicast`**Example:**

```
RP/0/RP0/CPU0:router(config-bgp)# address-family ipv6 unicast
```

Specifies IPv6 unicast address prefixes.

Step 9 `allocate-label [all | route-policy policy_name]`**Example:**

```
RP/0/RP0/CPU0:router(config-bgp-af)# allocate-label all
```

Allocates MPLS labels for specified IPv4 unicast routes.

Note The **route-policy** keyword provides finer control to filter out certain routes from being advertised to the neighbor.

Step 10 Use the **commit** or **end** command.

commit - Saves the configuration changes and remains within the configuration session.

end - Prompts user to take one of these actions:

- **Yes** - Saves configuration changes and exits the configuration session.
- **No** - Exits the configuration session without committing the configuration changes.
- **Cancel** - Remains in the configuration mode, without committing the configuration changes.

Configuring PE to PE Core

This task describes how to configure a Provider Edge (PE) to PE Core.

For information on configuring VPN Routing and Forwarding (VRF), refer to the *Implementing BGP* module of the *Routing Configuration Guide for Cisco CRS Routers*.

SUMMARY STEPS

1. **configure**
2. **router bgp**
3. **address-family vpnv6 unicast**
4. **bgp dampening** [*half-life* [*reuse suppress max-suppress-time*]] **route-policy** *route-policy-name*]
5. **bgp client-to-client reflection** { **cluster-id** | **disable** }
6. **neighbor** *ip-address*
7. **remote-as** *as-number*
8. **description** *text*
9. **password** { **clear** | **encrypted** } *password*
10. **shutdown**
11. **timers** *keepalive hold-time*
12. **update-source type** *interface-id*
13. **address-family vpnv6 unicast**
14. **route-policy** *route-policy-name* { **in** | **out** }
15. **exit**
16. **vrf** *vrf-name*
17. **rd** { *as-number : nn* | *ip-address : nn* | **auto** }
18. Use the **commit** or **end** command.

DETAILED STEPS

Step 1 **configure**

Example:

```
RP/0/RP0/CPU0:router# configure
```

Enters the Global Configuration mode.

Step 2 **router bgp**

Example:

```
RP/0/RP0/CPU0:router(config)# router bgp 10
```

Specifies the BGP AS number and enters the BGP configuration mode, allowing you to configure the BGP routing process.

Step 3 **address-family vpnv6 unicast**

Example:

```
RP/0/RP0/CPU0:router(config-bgp)# address-family vpnv6 unicast
```

Specifies the vpnv6 address family and enters address family configuration submode.

Step 4 **bgp dampening [half-life [reuse suppress max-suppress-time] | route-policy route-policy-name]**

Example:

```
RP/0/RP0/CPU0:router(config-bgp-af)# bgp dampening 30 1500 10000 120
```

Configures BGP dampening for the specified address family.

Step 5 **bgp client-to-client reflection { cluster-id | disable }**

Example:

```
RP/0/RP0/CPU0:router(config-bgp-af)# bgp client-to-client
reflection disable
```

Configures client to client route reflection.

Step 6 **neighbor ip-address**

Example:

```
RP/0/RP0/CPU0:router(config-bgp)# neighbor 10.0.0.1
```

Places the router in neighbor configuration mode for BGP routing and configures the neighbor IP address as a BGP peer.

Step 7 **remote-as as-number**

Example:

```
RP/0/RP0/CPU0:router(config-bgp-nbr)# remote-as 100
```

Creates a neighbor and assigns a remote autonomous system number to it.

Step 8 **description** *text***Example:**

```
RP/0/RP0/CPU0:router(config-bgp-nbr)# description neighbor 172.16.1.1
```

Provides a description of the neighbor. The description is used to save comments and does not affect software function.

Step 9 **password** { **clear** | **encrypted** } *password***Example:**

```
RP/0/RP0/CPU0:router(config-bgp-nbr)# password encrypted 123abc
```

Enables Message Digest 5 (MD5) authentication on the TCP connection between the two BGP neighbors.

Step 10 **shutdown****Example:**

```
RP/0/RP0/CPU0:router(config-bgp-nbr)# router bgp 1
```

Terminates any active sessions for the specified neighbor and removes all associated routing information.

Step 11 **timers** *keepalive hold-time***Example:**

```
RP/0/RP0/CPU0:router(config-bgp-nbr)# timers 12000 200
```

Set the timers for the BGP neighbor.

Step 12 **update-source type** *interface-id***Example:**

```
RP/0/RP0/CPU0:router(config-bgp-nbr)# update-source TenGigE 0/1/5/0
```

Allows iBGP sessions to use the primary IP address from a specific interface as the local address when forming an iBGP session with a neighbor.

Step 13 **address-family vpnv6 unicast****Example:**

```
RP/0/RP0/CPU0:router(config-bgp-nbr)# address-family vpnv6 unicast
```

Enters VPN neighbor address family configuration mode.

Step 14 **route-policy** *route-policy-name* { **in** | **out** }**Example:**

```
RP/0/RP0/CPU0:router(config-bgp-nbr-af)# route-policy pe-pe-vpn-out out
```

Specifies a routing policy for an outbound route. The policy can be used to filter routes or modify route attributes.

Step 15 **exit**

Example:

```
RP/0/RP0/CPU0:router(config-bgp-nbr-af)# exit
```

Exits address family configuration and neighbor submode.

Step 16 **vrf vrf-name**

Example:

```
RP/0/RP0/CPU0:router(config-bgp)# vrf vrf-pe
```

Configures a VRF instance.

Step 17 **rd { as-number : nn | ip-address : nn | auto }**

Example:

```
RP/0/RP0/CPU0:router(config-bgp-vrf)# rd 345:567
```

Configures the route distinguisher.

Use the auto keyword if you want the router to automatically assign a unique RD to the VRF.

Step 18 Use the **commit** or **end** command.

commit - Saves the configuration changes and remains within the configuration session.

end - Prompts user to take one of these actions:

- **Yes** - Saves configuration changes and exits the configuration session.
- **No** - Exits the configuration session without committing the configuration changes.
- **Cancel** - Remains in the configuration mode, without committing the configuration changes.

Configuring OSPFv3 as the Routing Protocol Between the PE and CE Routers

Perform this task to configure provider edge (PE)-to-customer edge (CE) routing sessions that use Open Shortest Path First version 3 (OSPFv3).

SUMMARY STEPS

1. **configure**
2. **router ospfv3 process-name**
3. **vrf vrf-name**
4. **capability vrf-lite**
5. **router-id {router-id | type interface-path-id }**
6. **domain-id type { 0005 | 0105 | 0205 | 8005 } value domain-id**
7. Do one of the following:

- **redistribute bgp** *process-id* [**metric** *metric-value*] [**metric-type** {1 | 2}] [**route-policy** *route-policy policy-name*] [**tag** *tag-value*]
 - **redistribute connected** [**metric** *metric-value*] [**metric-type** {1 | 2}] [**route-policy** *policy-name*] [**tag** *tag-value*]
 - **redistribute ospf** *process-id* [**match** {external [1 | 2] | internal | nssa-external [1 | 2]}] [**metric** *metric-value*] [**metric-type** {1 | 2}] [**route-policy** *policy-name*] [**tag** *tag-value*]
 - **redistribute static** [**metric** *metric-value*] [**metric-type** {1 | 2}] [**route-policy** *policy-name*] [**tag** *tag-value*]
 - **redistribute eigrp** *process-id* [**match** {external [1 | 2] | internal | nssa-external [1 | 2]}] [**metric** *metric-value*] [**metric-type** {1 | 2}] [**route-policy** *policy-name*] [**tag** *tag-value*]
 - **redistribute rip** [**metric** *metric-value*] [**metric-type** {1 | 2}] [**route-policy** *policy-name*] [**tag** *tag-value*]
8. **area** *area-id*
 9. **interface** {*type interface-path-id*}
 10. Use the **commit** or **end** command.

DETAILED STEPS

Step 1 **configure**

Example:

```
RP/0/RP0/CPU0:router# configure
```

Enters the Global Configuration mode.

Step 2 **router ospfv3 process-name**

Example:

```
RP/0/RP0/CPU0:router(config)# router ospfv3 109
```

Enters OSPF configuration mode allowing you to configure the OSPF version 3 routing process.

Step 3 **vrf vrf-name**

Example:

```
RP/0/RP0/CPU0:router(config-ospf)# vrf vrf_1
```

Configures a VPN routing and forwarding (VRF) instance and enters VRF configuration mode for OSPF routing.

Step 4 **capability vrf-lite**

Example:

```
RP/0/RP0/CPU0:router(config-ospf-vrf)# capability vrf-lite
```

Enables VRF Lite feature.

Step 5 **router-id {router-id | type interface-path-id}**

Example:

```
RP/0/RP0/CPU0:router(config-ospf-vrf)# router-id 172.20.10.10
```

Configures the router ID for the VRF.

Note Router ID configuration is required for each VRF.

Step 6 **domain-id type** { 0005 | 0105 | 0205 | 8005 } **value** *domain-id*

Example:

```
RP/0/RP0/CPU0:router(config-ospf-vrf)# domain-id type 0005 value CAFE00112233
```

Specifies the domain ID.

Step 7 Do one of the following:

- **redistribute bgp** *process-id* [**metric** *metric-value*] [**metric-type** {1 | 2}] [**route-policy**12*route-policy policy-name*] [**tag** *tag-value*]
- **redistribute connected** [**metric** *metric-value*] [**metric-type** {1 | 2}] [**route-policy***policy-name*] [**tag** *tag-value*]
- **redistribute ospf** *process-id* [**match** {**external** [1 | 2] | **internal** | **nssa-external** [1 | 2]}] [**metric** *metric-value*] [**metric-type** {1 | 2}] [**route-policy** *policy-name*] [**tag** *tag-value*]
- **redistribute static** [**metric** *metric-value*] [**metric-type** {1 | 2}] [**route-policy** *policy-name*] [**tag** *policy-name*] [**tag** *tag-value*]
- **redistribute eigrp** *process-id* [**match** {**external** [1 | 2] | **internal** | **nssa-external** [1 | 2]}] [**metric** *metric-value*] [**metric-type** {1 | 2}] [**route-policy** *policy-name*] [**tag** *tag-value*]
- **redistribute rip** [**metric** *metric-value*] [**metric-type** {1 | 2}] [**route-policy** *policy-name*] [**tag** *tag-value*]

Example:

```
RP/0/RP0/CPU0:router(config-ospf-vrf)# redistribute connected
```

Causes routes to be redistributed into OSPF. The routes that can be redistributed into OSPF are:

- Border Gateway Protocol (BGP)
- Connected
- Enhanced Interior Gateway Routing Protocol (EIGRP)
- OSPF
- Static
- Routing Information Protocol (RIP)

Step 8 **area** *area-id*

Example:

```
RP/0/RP0/CPU0:router(config-ospf-vrf)# area 0
```

Configures the OSPF area as area 0.

Step 9 **interface** {*type interface-path-id*}

Example:

```
RP/0/RP0/CPU0:router(config-ospf-vrf-ar)# interface GigabitEthernet 0/3/0/0
```

Associates interface GigabitEthernet 0/3/0/0 with area 0.

Step 10 Use the **commit** or **end** command.

commit - Saves the configuration changes and remains within the configuration session.

end - Prompts user to take one of these actions:

- **Yes** - Saves configuration changes and exits the configuration session.
- **No** - Exits the configuration session without committing the configuration changes.
- **Cancel** - Remains in the configuration mode, without committing the configuration changes.

Configuration Examples for 6PE/VPE

This section includes the following configuration example:

Configuring 6PE on a PE Router: Example

This sample configuration shows the configuration of 6PE on a PE router:

```
interface TenGigE0/3/0/0
  ipv6 address 2001::1/64
!
router isis ipv6-cloud
  net 49.0000.0000.0001.00
  address-family ipv6 unicast
    single-topology
  interface TenGigE0/3/0/0
    address-family ipv6 unicast
  !
!
router bgp 55400
  bgp router-id 54.6.1.1
  address-family ipv4 unicast
  !
  address-family ipv6 unicast
    network 55:5::/64
    redistribute connected
    redistribute isis ipv6-cloud
  !
neighbor 34.4.3.3
  remote-as 55400
  address-family ipv4 unicast
  !
  address-family ipv6 labeled-unicast
```

Configuring OSPFv3 6VPE: Example

This example shows you how to configure provider edge (PE)-to-customer edge (CE) routing sessions that use Open Shortest Path First version 3 (OSPFv3):

```
router ospfv3 0
  vrf V1
    router-id 100.0.0.2
    domain-id type 0005 value CAFE00112233
    domain-id secondary type 0105 value beef00000001
    domain-id secondary type 0205 value beef00000002
    capability vrf-lite
    redistribute bgp 1
    area 0
      interface POS0/3/0/1
  vrf V2
    router-id 200.0.0.2
    capability vrf-lite
    area 1
      interface POS0/3/0/2
```



CHAPTER 6

Implementing Layer 2 Tunnel Protocol Version 3

Layer 2 Tunnel Protocol Version 3 (L2TPv3) is an Internet Engineering Task Force (IETF) working group draft that provides several enhancements to L2TP, including the ability to tunnel any Layer 2 (L2) payload over L2TP. Specifically, L2TPv3 defines the L2TP protocol for tunneling Layer 2 payloads over an IP core network using L2 virtual private networks (VPNs).

For additional information about L2TPv3, see *MPLS VPNs over IP Tunnels on Cisco IOS XR Software*.

Feature History for Implementing Layer 2 Tunnel Protocol Version 3 on Cisco IOS XR

Release	Modification
Release 3.9.0	This feature was introduced.

- [Prerequisites for Layer 2 Tunnel Protocol Version 3, on page 139](#)
- [Information About Layer 2 Tunnel Protocol Version 3, on page 140](#)
- [How to Implement Layer 2 Tunnel Protocol Version 3, on page 146](#)
- [Configuration Examples for Layer 2 Tunnel Protocol Version 3, on page 162](#)

Prerequisites for Layer 2 Tunnel Protocol Version 3

The following prerequisites are required to implement L2TPv3:

- To perform these configuration tasks, your Cisco IOS XR software system administrator must assign you to a user group associated with a task group that includes the corresponding command task IDs. All command task IDs are listed in individual command references and in the *Cisco IOS XR Task ID Reference Guide*.

If you need assistance with your task group assignment, contact your system administrator.

- You must enable Cisco Express Forwarding (CEF) before you configure a cross-connect attachment circuit (AC) for a customer edge (CE) device.
- You must configure a Loopback interface on the router for originating and terminating the L2TPv3 traffic. The Loopback interface must have an IP address that is reachable from the remote provider edge (PE) device at the other end of an L2TPv3 control-channel.
- You must enable Simple Network Management Protocol (SNMP) notifications of L2TP session up and session down events.



Note A cross-connection is expressed as *xconnect* in the CLI.

Information About Layer 2 Tunnel Protocol Version 3

To configure the L2TPv3 feature, you should understand the following concepts:

L2TPv3 Operation

The following figure shows how the L2TPv3 feature is used to set up VPNs using Layer 2 tunneling over an IP network. All traffic between two customer network sites is encapsulated in IP packets carrying L2TP data messages and sent across an IP network. The backbone routers of the IP network treat the traffic as any other IP traffic and needn't know anything about the customer networks.

Figure 25: L2TPv3 Operation

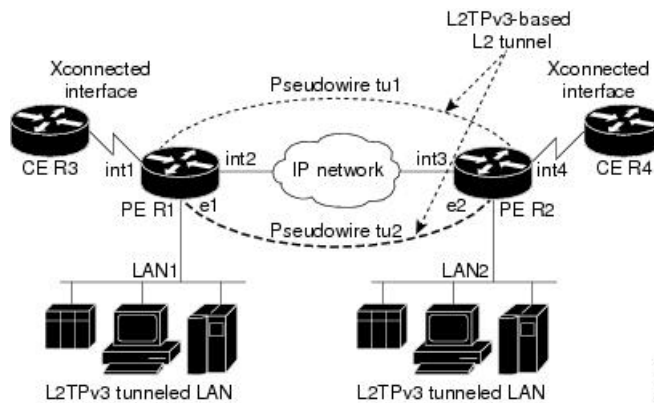

In the above figure the PE routers R1 and R2 provide L2TPv3 services. The R1 and R2 routers communicate with each other using a pseudowire over the IP backbone network through a path comprising the interfaces *int1* and *int2*, the IP network, and interfaces *int3* and *int4*. The CE routers R3 and R4 communicate through a pair of cross-connected Ethernet or 802.1q VLAN interfaces using an L2TPv3 session. The L2TPv3 session *tu1* is a pseudowire configured between interface *int1* on R1 and interface *int4* on R2. Any packet arriving on interface *int1* on R1 is encapsulated and sent through the pseudowire control-channel (*tu1*) to R2. R2 decapsulates the packet and sends it on interface *int4* to R4. When R4 needs to send a packet to R3, the packet follows the same path in reverse.

L2TPv3 Benefits

L2TPv3 provides the following benefits:

- Simplifies deployment of VPNs—L2TPv3 is an industry-standard L2 tunneling protocol that ensures interoperability among vendors, increasing customer flexibility and service availability.
- Does not require MPLS—Service providers need not deploy MPLS in the core IP backbone to set up VPNs using L2TPv3 over the IP backbone; this will result in operational savings and increased revenue.

- Supports L2 tunneling over IP for any payload—L2TPv3 provides enhancements to L2TP to support L2 tunneling of any payload over an IP core network. L2TPv3 defines the base L2TP protocol as being separate from the L2 payload that is tunneled.

L2TPv3 Features

L2TPv3 provides cross-connect support for Ethernet, and 802.1q (VLAN), Frame Relay, HDLC, and PPP, and ATM using the sessions described in the following sections:

- [Static L2TPv3 Sessions](#)
- [Dynamic L2TPv3 Sessions](#)

L2TPv3 also supports:

- [Local Switching](#)
- [Local Switching: Quality of Service](#)
- [L2TPv3 Pseudowire Switching](#)
- [L2TPv3 Pseudowire Manager](#)
- [IP Packet Fragmentation](#)
- [L2TPv3 Type of Service Marking](#)
- [Keepalive](#)
- [Maximum Transmission Unit Handling](#)
- Distributed switching
- L2TPv3 L2 fragmentation
- L2TPv3 control message hashing
- L2TPv3 control message rate limiting
- L2TPv3 digest secret graceful switchover
- Manual clearing of L2TPv3 tunnels
- L2TPv3 tunnel management
- Color aware policer on ethernet over L2TPv3
- Site of origin for BGP VPNs
- IPSec Mapping to L2TPv3
- [Like-to-Like Pseudowires](#)

Static L2TPv3 Sessions

Typically, the L2TP control plane is responsible for negotiating session parameters (such as the session ID or the cookie) to set up the session; however, some IP networks require sessions to be configured so that no signaling is required for session establishment. Therefore, you can set up static L2TPv3 sessions for a PE router by configuring fixed values for the fields in the L2TP data header. A static L2TPv3 session allows the PE to tunnel L2 traffic as soon as the AC to which the session is bound comes up.



Note In an L2TPv3 static session, you can still run the L2TP control-channel to perform peer authentication and dead-peer detection. If the L2TP control-channel cannot be established or is torn down because of a hello failure, the static session is also torn down.

Dynamic L2TPv3 Sessions

A dynamic L2TP session is established through the exchange of control messages containing attribute-value pair (AVP). Each AVP contains information about the nature of the L2 link being forwarded: including the payload type, virtual circuit (VC) ID, and so on.

Multiple L2TP sessions can exist between a pair of PEs, and can be maintained by a single control-channel. Session IDs and cookies are dynamically generated and exchanged as part of a dynamic session setup.

Local Switching

An AC to AC cross-connect, also called *local switching*, is a building block of L2VPN that allows frames to switch between two different ACs on the same PE. PE (see figure below).

You must configure separate IP addresses for each cross-connect statement on the Carrier Edge router.

The following configurations are supported for local switching:

- Port-to-Port
- Dot1q-to-Dot1q
- QinQ-to-QinQ
- QinAny-to-QinAny
- Dot1q-to-QinQ
- QinQ-to-Dot1q
- QinQ-to-QinAny
- QinAny-to-QinQ



Note VLAN-to-VLAN options do not require interworking.. If both interfaces are Ethernet VLAN, each reside on a single physical interface. By definition, local switching is not a pseudowire technology, because signaling protocols (such as LDP or L2TPv3) are not involved.

Figure 26: Local Switching Operation

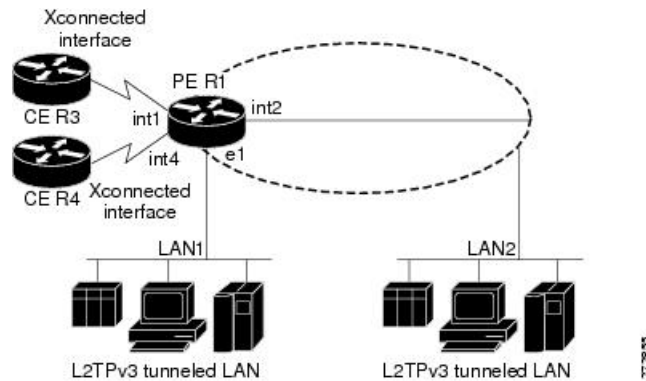

Local Switching: Quality of Service

The following quality of service (QoS) requirements apply to local switching:

- QoS service policies can be attached directly to the AC.
- QoS service policies can be attached to the main interface using **match vlan** on L2 VLAN ACs.
- QoS service policies attached to the main interface can be inherited by all L2 VLANs.
- QoS service policies cannot be attached to a main interface when there are service policies already attached to its L3VLANs or L2VLAN ACs.
- QoS service policies already attached to the main interface are not permitted on L3 VLAN or L2 VLAN ACs.

L2TPv3 Pseudowire Switching

L2VPN pseudowire switching allows you to:

- Extend L2VPN pseudowires across an Inter-AS boundary.
- Connect two or more contiguous pseudowire segments to form an end-to-end multihop pseudowire.
- Keep the IP addresses of the edge PE routers private across Inter-AS boundaries.
- Keep different administrative or provisioning domains to manage the end-to-end service.

L2TPv3 Pseudowire Manager

The pseudowire manager is a client library provided by the pseudowire signaling module that runs in the context of the L2VPN process. This client library implements interface to pseudo-wire signaling protocol for specific pseudowire type.

IP Packet Fragmentation

It is desirable to avoid fragmentation issues in the service provider network because reassembly is computationally expensive. The easiest way to avoid fragmentation issues is to configure the CE routers with an Maximum Transmission Unit (MTU) value that is smaller than the pseudowire path MTU. However, in scenarios where this is not an option, fragmentation issues must be considered. Previously, L2TP supported

only the following options for packet fragmentation when a packet is determined to exceed the L2TP path MTU:

- Unconditionally drop the packet
- Fragment the packet after L2TP/IP encapsulation
- Drop the packet and send an Internet Control Message Protocol (ICMP) unreachable message back to the CE router

Currently, the following options for packet fragmentation are supported:

- Path MTU is a configurable value which is configured on PE. If the packet size and the L2TP header size are larger than the configured path MTU, packets are dropped.
- The PE configuration requires that a backbone facing interface's MTU is always greater or equal to the customer facing interface's MTU and L2TP header size.
- IP fragmentation is not supported with L2TPv3.

L2TPv3 Type of Service Marking

When L2 traffic is tunneled across an IP network, information contained in the type of service (ToS) bits may be transferred to the L2TP-encapsulated IP packets in one of the following ways:

- If the tunneled L2 frames encapsulate IP packets themselves, it may be desirable to simply copy the ToS bytes of the inner IP packets to the outer IP packet headers. This action is known as “ToS byte reflection.”
- Static ToS byte configuration. You specify the ToS byte value used by all packets sent across the pseudowire.

Keepalive

The keepalive mechanism for L2TPv3 extends only to the endpoints of the tunneling protocol. L2TP has a reliable control message delivery mechanism that serves as the basis for the keepalive mechanism. The keepalive mechanism consists of an exchange of L2TP hello messages.

If a keepalive mechanism is required, the control plane is used, although it may not be used to bring up sessions. You can manually configure sessions.

In the case of static L2TPv3 sessions, a control channel between the two L2TP peers is negotiated through the exchange of start control channel request (SCCRQ), start control channel replay (SCCRP), and start control channel connected (SCCCN) control messages. The control channel is responsible only for maintaining the keepalive mechanism through the exchange of hello messages.

The interval between hello messages is configurable per control channel. If one peer detects that the other has gone down through the keepalive mechanism, it sends a StopCCN control message and then notifies all of the pseudowires to the peer about the event. This notification results in the teardown of both manually configured and dynamic sessions.

Maximum Transmission Unit Handling

It is important that you configure an maximum transmission unit (MTU) appropriate for a each L2TPv3 tunneled link. The configured MTU size ensures that the lengths of the tunneled L2 frames fall below the MTU of the destination AC.

L2TPv3 handles the MTU as follows:

- Configure the path MTU on the PE. If the packet size and the L2TP header collectively are larger than the configured value, packets are dropped.

IP Security Mapping to L2 Tunneling Protocol, Version 3



Note This feature is supported only on the Cisco IPsec VPN SPA.

The L2TPv3 is a protocol that is used to tunnel a variety of payload types over IP networks. IP security (IPsec) provides an additional level of protection at a service PE router than relying on access control list (ACL) filters. L2TPv3 tunnels are also secured by using IPsec, as specified in RFC3931.

You can secure L2TPv3 tunnels by using IPsec, which provides authentication, privacy protection, integrity checking, and replay protection. When using IPsec, the tunnel head and the tunnel tail can be treated as the endpoints of an SA. A single IP address of the tunnel head is used as the source IP address, and a single IP address of the tunnel tail is used as the destination IP address.

The following scenarios are described to have L2TPv3 work with IPsec:

IPsec Mapping to L2TPv3

A CE 1 router sends an IPsec packet to a PE1 router. The PE1 router sends an IPsec packet to the Cisco IPsec VPN SPA by routing the look up for the front door virtual routing and forwarding (FVRF) in the service-ipsec interface. The Cisco IPsec VPN SPA can decapsulate an IPsec packet to obtain a clear IP packet, and perform a routing look up for the inside virtual routing and forwarding (IVRF) in the service-ipsec interface.

IPsec over L2TPv3

If the packet arrives at PE1 outside of a virtual routing and forwarding (VRF), for example, the global table, the packet is forwarded to the PE2 according to the global FIB in PE1. This is normal for IP switching until the packet arrives at PE2 with no encapsulation at any point.

Like-to-Like Pseudowires

A PseudoWire (PW) is a bidirectional virtual circuit (VC) connecting two Attached Circuits (ACs). In an MPLS network, PWs are carried inside an LSP tunnel.

The ATM like-to-like pseudowires support the following modes:

A point-to-point (PPP) connection allows service providers to provide a transparent PPP pass-through where the customer-edge routers can exchange the traffic through an end-to-end PPP session. Service providers can offer a virtual leased-line solution, and use the PPP subinterface capability to peer with multiple providers through a single POS connection.



Note In an MPLS network, pseudowires are carried inside an LSP tunnel.

How to Implement Layer 2 Tunnel Protocol Version 3

This section includes the tasks required to implement L2TPv3, as follows:

Configuring a Pseudowire Class

Perform this task to configure a pseudowire class, or template.

SUMMARY STEPS

1. **configure**
2. **l2vpn**
3. **pw-class** *class name*
4. **encapsulation** { **mpls** | **l2tpv3** }
5. **protocol** **l2tpv3** **class** *class name*
6. **ipv4 source** *ip-address*
7. **transport-mode** { **ethernet** | **vlan** }
8. Use the **commit** or **end** command.

DETAILED STEPS

Step 1 **configure**

Example:

```
RP/0/RP0/CPU0:router# configure
```

Enters the Global Configuration mode.

Step 2 **l2vpn**

Example:

```
RP/0/RP0/CPU0:router(config)# l2vpn
```

Enter L2VPN configure submode.

Step 3 **pw-class** *class name*

Example:

```
RP/0/RP0/CPU0:router(config-l2vpn)# pw-class wkg
```

Enters a pseudowire-class name.

Step 4 **encapsulation** { **mpls** | **l2tpv3** }

Example:

```
RP/0/RP0/CPU0:router (config-l2tp-pwc) # encapsulation l2tpv3
```

Configures pseudowire encapsulation to the Layer 2 Tunnel Protocol.

Step 5 **protocol l2tpv3 class** *class name*

Example:

```
RP/0/RP0/CPU0:router (config-l2tp-pwc-encap-l2tpv3) # protocol l2tpv3 class Class_l2tp_01
```

Configures the L2TPv3 dynamic pseudowire signaling protocol to be used to manage the pseudowires created.

Note Ensure that the L2TPv3 class name begins with a letter (A to Z or a to z). The class name can contain letters (A to Z or a to z) or numbers (0 to 9) and other characters such as underscore (_), hyphen (-) or period (.). A maximum of 31 characters can be used in the class name.

Step 6 **ipv4 source** *ip-address*

Example:

```
RP/0/RP0/CPU0:router (config-l2tp-pwc-encap-l2tpv3) # ipv4 source 126.10.1.55
```

Configures the local source IPv4 address.

Step 7 **transport-mode { ethernet | vlan }**

Example:

```
RP/0/RP0/CPU0:router (config-l2tp-pwc-encap-l2tpv3) # transport-mode ethernet
```

Configures the remote transport mode.

Step 8 Use the **commit** or **end** command.

commit - Saves the configuration changes and remains within the configuration session.

end - Prompts user to take one of these actions:

- **Yes** - Saves configuration changes and exits the configuration session.
- **No** - Exits the configuration session without committing the configuration changes.
- **Cancel** - Remains in the configuration mode, without committing the configuration changes.

Configuring L2TP Control-Channel Parameters

This section describes the tasks you must perform to create a template of L2TP control-channel parameters that can be inherited by different pseudowire classes. The three main parameters described are:

- Timing parameters
- Authentication parameters
- Maintenance parameters

L2TP control-channel parameters are used in control-channel authentication, keepalive messages, and control-channel negotiation. In a L2tpv3 session, the same L2tp class must be configured on both PE routers.

The three main groups of L2TP control-channel parameters that you can configure in an L2TP class are described in the following subsections:

- [Configuring L2TP Control-Channel Timing Parameters](#)
- [Configuring L2TPv3 Control-Channel Authentication Parameters](#)
- [Configuring L2TP Control-Channel Maintenance Parameters](#)



Note When you enter L2TP class configuration mode, you can configure L2TP control-channel parameters in any order. If you have multiple authentication requirements you can configure multiple sets of L2TP class control-channel parameters with different L2TP class names. However, only one set of L2TP class control-channel parameters can be applied to a connection between any pair of IP addresses.

Configuring L2TP Control-Channel Timing Parameters

The following L2TP control-channel timing parameters can be configured in L2TP class configuration mode:

- Packet size of the receive window used for the control-channel.
- Retransmission parameters used for control messages.
- Timeout parameters used for the control-channel.



Note This task configures a set of timing control-channel parameters in an L2TP class. All timing control-channel parameter configurations can be configured in any order. If not configured, the default values are applied.

SUMMARY STEPS

1. **configure**
2. **l2tp-class** *l2tp-class-name*
3. **receive-window** *size*
4. **retransmit** { **initial retries** *initial-retries* | **retries** *retries* | **timeout** { **max** | **min** } *timeout* }
5. **timeout setup** *seconds*

DETAILED STEPS

Step 1 **configure**

Example:

```
RP/0/RP0/CPU0:router# configure
```

Enters the Global Configuration mode.

Step 2 **l2tp-class** *l2tp-class-name*

Example:

```
RP/0/RP0/CPU0:router(config)# l2tp-class cisco
```

Specifies the L2TP class name and enters L2TP class configuration mode.

Step 3 **receive-window** *size*

Example:

```
RP/0/RP0/CPU0:router(config-l2tp-class)# receive-window 30
```

Configures the number of packets that can be received by the remote peer before backoff queuing occurs.

The default value is 512.

Step 4 **retransmit** { **initial retries** *initial-retries* | **retries** *retries* | **timeout** { **max** | **min** } *timeout* }

Example:

```
RP/0/RP0/CPU0:router(config-l2tp-class)# retransmit retries 10
```

Configures parameters that affect the retransmission of control packets.

- **initial retries**—Specifies how many SCCRQs are re-sent before giving up on the session. Range is 1 to 1000. The default is 2.
- **retries**—Specifies how many retransmission cycles occur before determining that the peer PE router does not respond. Range is 1 to 1000. The default is 15.
- **timeout** { **max** | **min** }—Specifies maximum and minimum retransmission intervals (in seconds) for resending control packets. Range is 1 to 8. The default maximum interval is 8; the default minimum interval is 1.

Step 5 **timeout setup** *seconds*

Example:

```
RP/0/RP0/CPU0:router(config-l2tp-class)# timeout setup 400
```

Configures the amount of time, in seconds, allowed to set up a control-channel.

- Range is 60 to 6000. Default value is 300.

Configuring L2TPv3 Control-Channel Authentication Parameters

Two methods of control-channel message authentication are available:

- L2TP Control-Channel (see [Configuring Authentication for the L2TP Control-Channel](#))
- L2TPv3 Control Message Hashing (see [Configuring L2TPv3 Control Message Hashing](#))

You can enable both methods of authentication to ensure interoperability with peers that support only one of these methods of authentication, but this configuration will yield control of which authentication method is used to the peer PE router. Enabling both methods of authentication should be considered an interim solution to solve backward-compatibility issues during software upgrades.

The principal difference between the L2TPv3 Control Message Hashing feature and CHAP-style L2TP control-channel authentication is that, instead of computing the hash over selected contents of a received control message, the L2TPv3 Control Message Hashing feature uses the entire message in the hash. In addition, instead of including the hash digest in only the SCCRP and SCCCN messages, it includes it in all messages.

This section also describes how to configure L2TPv3 digest secret graceful switchover (see Configuring L2TPv3 Digest Secret Graceful Switchover) which lets you make the transition from an old L2TPv3 control-channel authentication password to a new L2TPv3 control-channel authentication password without disrupting established L2TPv3 tunnels.



Note Support for L2TP control-channel authentication is maintained for backward compatibility. Either or both authentication methods can be enabled to allow interoperability with peers supporting only one of the authentication methods.

Configuring Authentication for the L2TP Control-Channel

The L2TP control-channel method of authentication is the older, CHAP-like authentication system inherited from L2TPv2.

The following L2TP control-channel authentication parameters can be configured in L2TP class configuration mode:

- Authentication for the L2TP control-channel
- Password used for L2TP control-channel authentication
- Local hostname used for authenticating the control-channel

This task configures a set of authentication control-channel parameters in an L2TP class. All of the authentication control-channel parameter configurations may be configured in any order. If these parameters are not configured, the default values are applied.

SUMMARY STEPS

1. **configure**
2. **l2tp-class** *word*
3. **authentication**
4. **password** {0 | 7} *password*
5. **hostname** *name*

DETAILED STEPS

Step 1 **configure**

Example:

```
RP/0/RP0/CPU0:router# configure
```

Enters the Global Configuration mode.

Step 2 **l2tp-class** *word*

Example:

```
RP/0/RP0/CPU0:router(config)# l2tp-class class1
```

Specifies the L2TP class name and enters L2TP class configuration mode.

Step 3 authentication

Example:

```
RP/0/RP0/CPU0:router(config-l2tp-class)# authentication
```

Enables authentication for the control-channel between PE routers.

Step 4 password {0 | 7} password

Example:

```
RP/0/RP0/CPU0:router(config-l2tp-class)# password 7 cisco
```

Configures the password used for control-channel authentication.

- **[0 | 7]**—Specifies the input format of the shared secret. The default value is 0.
 - **0**—Specifies an encrypted password will follow.
 - **7**—Specifies an unencrypted password will follow.
- *password*—Defines the shared password between peer routers.

Step 5 hostname name

Example:

```
RP/0/RP0/CPU0:router(config-l2tp-class)# hostname yb2
```

Specifies a hostname used to identify the router during L2TP control-channel authentication.

- If you do not use this command, the default hostname of the router is used.

Configuring L2TPv3 Control Message Hashing

Perform this task to configure L2TPv3 Control Message Hashing feature for an L2TP class.

L2TPv3 control message hashing incorporates authentication or integrity check for all control messages. This per-message authentication is designed to guard against control message spoofing and replay attacks that would otherwise be trivial to mount against the network.

Enabling the L2TPv3Control Message Hashing feature will impact performance during control-channel and session establishment because additional digest calculation of the full message content is required for each sent and received control message. This is an expected trade-off for the additional security afforded by this feature. In addition, network congestion may occur if the receive window size is too small. If the L2TPv3 Control Message Hashing feature is enabled, message digest validation must be enabled. Message digest validation deactivates the data path received sequence number update and restricts the minimum local receive window size to 35.

You can configure control-channel authentication or control message integrity checking; however, control-channel authentication requires participation by both peers, and a shared secret must be configured on both routers. Control message integrity check is unidirectional, and requires configuration on only one of the peers.

SUMMARY STEPS

1. **configure**
2. **l2tp-class** *word*
3. **digest** { **check disable** | **hash** { **MD5** | **SHA1** }] | **secret** { **0** | **7** } *password*]
4. **hidden**

DETAILED STEPS

Step 1 **configure**

Example:

```
RP/0/RP0/CPU0:router# configure
```

Enters the Global Configuration mode.

Step 2 **l2tp-class** *word*

Example:

```
RP/0/RP0/CPU0:router(config)# l2tp-class class1
```

Specifies the L2TP class name and enters L2TP class configuration mode.

Step 3 **digest** { **check disable** | **hash** { **MD5** | **SHA1** }] | **secret** { **0** | **7** } *password*]

Example:

```
RP/0/RP0/CPU0:router(config-l2tp-class)# digest secret cisco hash sha
```

Enables L2TPv3 control-channel authentication or integrity checking.

- **secret**—Enables L2TPv3 control-channel authentication.

Note If the **digest** command is issued without the **secret** keyword option, L2TPv3 integrity checking is enabled.

- **{0 | 7}**—Specifies the input format of the shared secret. The default value is **0**.
 - **0**—Specifies that a plain-text secret is entered.
 - **7**—Specifies that an encrypted secret is entered.
- *password*—Defines the shared secret between peer routers. The value entered for the *password* argument must be in the format that matches the input format specified by the **{0 | 7}** keyword option.
- **hash** { **MD5** | **SHA1** }—Specifies the hash function to be used in per-message digest calculations.
 - **MD5**—Specifies HMAC-MD5 hashing (default value).
 - **SHA1**—Specifies HMAC-SHA-1 hashing.

Step 4 **hidden****Example:**

```
RP/0/RP0/CPU0:router(config-l2tp-class)# hidden
```

Enables AVP hiding when sending control messages to an L2TPv3 peer.

Configuring L2TPv3 Digest Secret Graceful Switchover

Perform this task to make the transition from an old L2TPv3 control-channel authentication password to a new L2TPv3 control-channel authentication password without disrupting established L2TPv3 tunnels.



Note This task is not compatible with authentication passwords configured with the older, CHAP-like control-channel authentication system.

L2TPv3 control-channel authentication occurs using a password that is configured on all participating peer PE routers. The L2TPv3 Digest Secret Graceful Switchover feature allows a transition from an old control-channel authentication password to a new control-channel authentication password without disrupting established L2TPv3 tunnels.

Before performing this task, you must enable control-channel authentication (see Configuring L2TPv3 Control Message Hashing).



Note During the period when both a new and an old password are configured, authentication can occur only with the new password if the attempt to authenticate using the old password fails.

SUMMARY STEPS

1. **configure**
2. **l2tp-class** *word*
3. **digest** {**check disable** | **hash** {**MD5** | **SHA1**} } | **secret** {**0** | **7**} *password*
4. Use the **commit** or **end** command.
5. **show l2tp tunnel brief**
6. **configure**
7. **l2tp-class** *word*
8. **no digest** [**secret** [**0** | **7**] *password* [**hash** { **md5** | **sha** }]
9. Use the **commit** or **end** command.
10. **show l2tp tunnel brief**

DETAILED STEPS**Step 1** **configure**

Example:

```
RP/0/RP0/CPU0:router# configure
```

Enters the Global Configuration mode.

Step 2 `l2tp-class word`**Example:**

```
RP/0/RP0/CPU0:router(config)# l2tp-class class1
```

Specifies the L2TP class name and enters L2TP class configuration mode.

Step 3 `digest {check disable | hash {MD5 | SHA1} } | secret {0 | 7} password]`**Example:**

```
RP/0/RP0/CPU0:router(config-l2tp-class)# digest secret cisco hash sha
```

Enables L2TPv3 control-channel authentication or integrity checking.

- **secret**—Enables L2TPv3 control-channel authentication.

Note If the **digest** command is issued without the **secret** keyword option, L2TPv3 integrity checking is enabled.

- **{ 0 | 7 }**—Specifies the input format of the shared secret. The default value is **0**.
 - **0**—Specifies that a plain-text secret is entered.
 - **7**—Specifies that an encrypted secret is entered.
- *password*—Defines the shared secret between peer routers. The value entered for the *password* argument must be in the format that matches the input format specified by the **{ 0 | 7 }** keyword option.
- **hash {MD5 | SHA1}**—Specifies the hash function to be used in per-message digest calculations.
 - **MD5**—Specifies HMAC-MD5 hashing (default value).
 - **SHA1**—Specifies HMAC-SHA-1 hashing.

Step 4 Use the **commit** or **end** command.

commit - Saves the configuration changes and remains within the configuration session.

end - Prompts user to take one of these actions:

- **Yes** - Saves configuration changes and exits the configuration session.
- **No** - Exits the configuration session without committing the configuration changes.
- **Cancel** - Remains in the configuration mode, without committing the configuration changes.

Step 5 `show l2tp tunnel brief`**Example:**

```
RP/0/RP0/CPU0:router# show l2tun tunnel brief
```

Displays the current state of L2 tunnels and information about configured tunnels, including local and remote L2 Tunneling Protocol (L2TP) hostnames, aggregate packet counts, and control-channel information.

Note Use this command to determine if any tunnels are not using the new password for control-channel authentication. The output displayed for each tunnel in the specified L2TP class should show that two secrets are configured.

Step 6 **configure**

Example:

```
RP/0/RP0/CPU0:router# configure
```

Enters the Global Configuration mode.

Step 7 **l2tp-class word**

Example:

```
RP/0/RP0/CPU0:router(config)# l2tp-class class1
```

Specifies the L2TP class name and enters L2TP class configuration mode.

Step 8 **no digest [secret [0 | 7] password [hash { md5 | sha }]**

Example:

```
RP/0/RP0/CPU0:router(config-l2tp-class)# no digest secret cisco hash sha1
```

Disables L2TPv3 control-channel authentication or integrity checking.

Step 9 Use the **commit** or **end** command.

commit - Saves the configuration changes and remains within the configuration session.

end - Prompts user to take one of these actions:

- **Yes** - Saves configuration changes and exits the configuration session.
- **No** - Exits the configuration session without committing the configuration changes.
- **Cancel** - Remains in the configuration mode, without committing the configuration changes.

Step 10 **show l2tp tunnel brief**

Example:

```
RP/0/RP0/CPU0:router# show l2tun tunnel brief
```

Displays the current state of L2 tunnels and information about configured tunnels, including local and remote L2 Tunneling Protocol (L2TP) hostnames, aggregate packet counts, and control-channel information.

Tunnels should no longer be using the old control-channel authentication password. If a tunnel does not update to show that only one secret is configured after several minutes have passed, that tunnel can be manually cleared and a defect report should be filed with TAC.

Note Issue this command to ensure that all tunnels are using only the new password for control-channel authentication. The output displayed for each tunnel in the specified L2TP class should show that one secret is configured.

Configuring L2TP Control-Channel Maintenance Parameters

Perform this task to configure the interval used for hello messages in an L2TP class.

SUMMARY STEPS

1. **configure**
2. **l2tp-class** *word*
3. **hello** *interval*

DETAILED STEPS

Step 1 **configure**

Example:

```
RP/0/RP0/CPU0:router# configure
```

Enters the Global Configuration mode.

Step 2 **l2tp-class** *word*

Example:

```
RP/0/RP0/CPU0:router(config)# l2tp-class class1
```

Specifies the L2TP class name and enters L2TP class configuration mode.

Step 3 **hello** *interval*

Example:

```
RP/0/RP0/CPU0:router(config-l2tp-class)# hello 100
```

Specifies the exchange interval (in seconds) used between L2TP hello packets.

- Valid values for the *interval* argument range from 0 to 1000. The default value is 60.

Configuring L2TPv3 Pseudowires

Perform the following tasks to configure static and dynamic L2TPv3 pseudowires:

Configuring a Dynamic L2TPv3 Pseudowire

Perform this task to configure a dynamic L2TPv3 pseudowire.

SUMMARY STEPS

1. **configure**
2. **l2vpn**

3. **xconnect group** *name*
4. **p2p** *name*
5. **neighbor** *ip-address* **pw-id** *number*
6. **pw-class** *pw-class-name*
7. Use the **commit** or **end** command.
8. **pw-class** *pw-class-name*
9. **encapsulation l2tpv3**
10. **protocol l2tpv3 class** *class - name*
11. Use the **commit** or **end** command.

DETAILED STEPS

Step 1 **configure**

Example:

```
RP/0/RP0/CPU0:router# configure
```

Enters the Global Configuration mode.

Step 2 **l2vpn**

Example:

```
RP/0/RP0/CPU0:router(config)# l2vpn
```

Enter L2VPN configure submode.

Step 3 **xconnect group** *name*

Example:

```
RP/0/RP0/CPU0:router(config-l2vpn)# xconnect group grp_01
```

Enter a name for the cross-connect group.

Step 4 **p2p** *name*

Example:

```
RP/0/RP0/CPU0:router(config-l2vpn-xc)# p2p AC1_to_PW1
```

Enters p2p configuration submode to configure point-to-point cross-connects.

Step 5 **neighbor** *ip-address* **pw-id** *number*

Example:

```
RP/0/RP0/CPU0:router(config-l2vpn-xc-p2p)# neighbor 10.1.1.1 pw-id 665
```

Configures a pseudowire for a cross-connect.

Step 6 **pw-class** *pw-class-name*

Example:

```
RP/0/RP0/CPU0:router(config-l2vpn-xc-p2p-pw)# pw-class atom
```

Enters pseudowire class submode to define a name for the cross-connect.

Step 7 Use the **commit** or **end** command.

commit - Saves the configuration changes and remains within the configuration session.

end - Prompts user to take one of these actions:

- **Yes** - Saves configuration changes and exits the configuration session.
- **No** - Exits the configuration session without committing the configuration changes.
- **Cancel** - Remains in the configuration mode, without committing the configuration changes.

Step 8 **pw-class** *pw-class-name*

Example:

```
RP/0/RP0/CPU0:router(config-l2vpn)# pw-class class100
```

Enters pseudowire class submode to define a pseudowire class template.

Step 9 **encapsulation l2tpv3**

Example:

```
RP/0/RP0/CPU0:router(config-l2vpn-pwc)# encapsulation l2tpv3
```

Configures L2TPv3 pseudowire encapsulation.

Step 10 **protocol l2tpv3 class** *class - name*

Example:

```
RP/0/RP0/CPU0:router(config-l2vpn-pwc-encap-l2tpv3)# protocol l2tpv3 class wkg
```

Configures the dynamic pseudowire signaling protocol.

Step 11 Use the **commit** or **end** command.

commit - Saves the configuration changes and remains within the configuration session.

end - Prompts user to take one of these actions:

- **Yes** - Saves configuration changes and exits the configuration session.
- **No** - Exits the configuration session without committing the configuration changes.
- **Cancel** - Remains in the configuration mode, without committing the configuration changes.

Configuring a Static L2TPv3 Pseudowire

Perform this task to configure a static L2TPv3 pseudowire.

SUMMARY STEPS

1. **configure**
2. **l2vpn**

3. **xconnect group** *name*
4. **p2p** *name*
5. **neighbor** *ip-address* **pw-id** *number*
6. **l2tp static local session** { *session-id* }
7. **l2tp static local cookie size** { 0 | 4 | 8 } [**value** { *low-value* } [{ *high-value* }]]
8. **l2tp static remote session** { *session-id* }
9. **l2tp static remote cookie size** { 0 | 4 | 8 } [**value** { *low-value* } [{ *high-value* }]]
10. **pw-class** *name*
11. Use the **commit** or **end** command.
12. **configure**
13. **l2vpn**
14. **pw-class** *name*
15. **encapsulation l2tpv3**
16. **ipv4 source** *ip-address*
17. Use the **commit** or **end** command.

DETAILED STEPS

Step 1 **configure**

Example:

```
RP/0/RP0/CPU0:router# configure
```

Enters the Global Configuration mode.

Step 2 **l2vpn**

Example:

```
RP/0/RP0/CPU0:router(config)# l2vpn
```

Enter L2VPN configure submode.

Step 3 **xconnect group** *name*

Example:

```
RP/0/RP0/CPU0:router(config-l2vpn)# xconnect group customer_X
```

Enter a name for the cross-connect group.

Step 4 **p2p** *name*

Example:

```
RP/0/RP0/CPU0:router(config-l2vpn-xc)# p2p AC1_to_PW1
```

Enters p2p configuration submode to configure point-to-point cross-connects.

Step 5 **neighbor** *ip-address* **pw-id** *number*

Example:

```
RP/0/RP0/CPU0:router(config-l2vpn-xc-p2p)# neighbor 10.1.1.1 pw-id 666
```

Configures a pseudowire for a cross-connect.

Step 6 **l2tp static local session** { *session-id* }**Example:**

```
RP/0/RP0/CPU0:router(config-l2vpn-xc-p2p-pw)# l2tp static local session 147
```

Configures a L2TP pseudowire static session ID.

Step 7 **l2tp static local cookie size** { **0** | **4** | **8** } [**value** { *low-value* } [{ *high-value* }]]**Example:**

```
RP/0/RP0/CPU0:router(config-l2vpn-xc-p2p-pw)# l2tp static local cookie size 4 value 0XA
```

Configures a L2TP pseudowire static session cookie.

Step 8 **l2tp static remote session** { *session-id* }**Example:**

```
RP/0/RP0/CPU0:router(config-l2vpn-xc-p2p-pw)# l2tp static remote session 123
```

Configures a L2TP pseudowire remote session ID.

Step 9 **l2tp static remote cookie size** { **0** | **4** | **8** } [**value** { *low-value* } [{ *high-value* }]]**Example:**

```
RP/0/RP0/CPU0:router(config-l2vpn-xc-p2p-pw)# l2tp static remote cookie size 8 value 0x456 0xFFB
```

Configures a L2TP pseudowire remote session cookie.

Step 10 **pw-class** *name***Example:**

```
RP/0/RP0/CPU0:router(config-l2vpn-xc-p2p-pw)# pw-class atom
```

Enters pseudowire class submode to define a pseudowire class template.

Step 11 Use the **commit** or **end** command.

commit - Saves the configuration changes and remains within the configuration session.

end - Prompts user to take one of these actions:

- **Yes** - Saves configuration changes and exits the configuration session.
- **No** - Exits the configuration session without committing the configuration changes.
- **Cancel** - Remains in the configuration mode, without committing the configuration changes.

Step 12 **configure****Example:**

```
RP/0/RP0/CPU0:router# configure
```

Enters the Global Configuration mode.

Step 13 **l2vpn****Example:**

```
RP/0/RP0/CPU0:router(config)# l2vpn
```

Enter L2VPN configure submode.

Step 14 **pw-class name****Example:**

```
RP/0/RP0/CPU0:router(config-l2vpn)# pw-class class100
```

Enters pseudowire class submode to define a pseudowire class template.

Step 15 **encapsulation l2tpv3****Example:**

```
RP/0/RP0/CPU0:router(config-l2vpn-pwc)# encapsulation l2tpv3
```

Configures L2TPv3 pseudowire encapsulation.

Step 16 **ipv4 source ip-address****Example:**

```
RP/0/RP0/CPU0:router(config-l2tp-pwc-encap-l2tpv3)# ipv4 source 126.10.1.55
```

Configures the local source IPv4 address.

Step 17 Use the **commit** or **end** command.

commit - Saves the configuration changes and remains within the configuration session.

end - Prompts user to take one of these actions:

- **Yes** - Saves configuration changes and exits the configuration session.
 - **No** - Exits the configuration session without committing the configuration changes.
 - **Cancel** - Remains in the configuration mode, without committing the configuration changes.
-

Configuration Examples for Layer 2 Tunnel Protocol Version 3

This section provides the following configuration examples:

Configuring an L2TP Class for L2TPv3-based L2VPN PE Routers: Example

The following example shows how to configure a L2TP class with L2TPv3 based L2VPN for a PE router

```
configure
l2tp-class Class_l2tp_01
  receive-window 256
  retransmit retries 8
  retransmit initial retries 10
  retransmit initial timeout max 4
  retransmit initial timeout min 2
  timeout setup 90
  hostname PE1
  hello-interval 100
  digest secret cisco hash MD5
end
```

Configuring a Pseudowire Class: Example

The following example shows a pseudowire class configuration on a PE router:

```
configure
l2vpn
pw-class FR1
  encapsulation l2tpv3
  protocol l2tpv3 [class {class name}]
  sequencing both [resync {5-65535}]
  dfbit set
  tos {reflect|value {value}}
  ttl {1-255}
  pmtu max {68-65535}
  ipv4 source {ipv4_address}
  cookie size {0|4|8}
```

Configuring L2TPv3 Control Channel Parameters: Example

The following example shows a typical L2TPv3 control-channel configuration:

```
configure
l2tp-class FR-l2tp
  authentication
  hostname R2-PE1
  password 7 121A0C041104
  hello-interval 10
  digest secret 7 02050D480809
```

Configuring an Interface for Layer 2 Transport Mode: Example

The following example shows how to configure an interface to operate in Layer 2 transport mode:

```
configure
interface GigabitEthernet0/4/0/5 l2transport
 negotiation auto

l2vpn
xconnect group PP-2101
 p2p xc2101
  interface GigabitEthernet0/4/0/5
   neighbor 150.150.150.250 pw-id 5
   pw-class l2tpv3_class100
  !
 !
```



CHAPTER 7

Implementing MPLS Layer 3 VPNs

A Multiprotocol Label Switching (MPLS) Layer 3 Virtual Private Network (VPN) consists of a set of sites that are interconnected by means of an MPLS provider core network. At each customer site, one or more customer edge (CE) routers attach to one or more provider edge (PE) routers.

This module provides the conceptual and configuration information for MPLS Layer 3 VPNs on Cisco IOS XR software.



Note You must acquire an evaluation or permanent license in order to use MPLS Layer 3 VPN functionality. However, if you are upgrading from a previous version of the software, MPLS Layer 3 VPN functionality will continue to work using an implicit license for 90 days (during which time, you can purchase a permanent license). For more information about licenses, see the *Software Entitlement on the Cisco IOS XR Software* module in the *System Management Configuration Guide for Cisco CRS Routers*.

Feature History for Implementing MPLS Layer 3 VPNs

Release	Modification
Release 3.3.0	This feature was introduced.
Release 3.4.0	Support was added for MPLS L3VPN Carrier Supporting Carrier (CSC) functionality, including conceptual information and configuration tasks.
Release 3.5.0	Support was added for 6VPE. MPLS L3VPN Carrier Supporting Carrier (CSC) information was upgraded.
Release 3.6.0	Support was added for Inter-AS and CSC over IP Tunnels.
Release 3.7.0	Support was added for: <ul style="list-style-type: none">• IPv6 VPN Provider Edge (6VPE).• Inter-AS support for 6VPE.
Release 3.9.0	Support for Generic Routing Encapsulation (GRE) was added.

Release	Modification
Release 3.7.2	This feature was introduced.
Release 4.2.0	Support for Generic Routing Encapsulation (GRE) was added on A9K-SIP-700 line card.
Release 4.2.1	The maximum number of supported tunnel interfaces was increased to 2000 for the ASR 9000 Enhanced Ethernet and ASR 9000 Ethernet line cards.

- [Prerequisites for Implementing MPLS L3VPN](#), on page 166
- [MPLS L3VPN Restrictions](#), on page 167
- [Information About MPLS Layer 3 VPNs](#), on page 167
- [Inter-AS Support for L3VPN](#), on page 171
- [Carrier Supporting Carrier Support for L3VPN](#), on page 184
- [IPv6 VPN Provider Edge \(6VPE\) Support](#), on page 187
- [How to Implement MPLS Layer 3 VPNs](#), on page 189
- [Configuring 6VPE Support](#), on page 251
- [Configuration Examples for Implementing MPLS Layer 3 VPNs](#), on page 256

Prerequisites for Implementing MPLS L3VPN

The following prerequisites are required to configure MPLS Layer 3 VPN:

- To perform these configuration tasks, your Cisco IOS XR software system administrator must assign you to a user group associated with a task group that includes the corresponding command task IDs. All command task IDs are listed in individual command references and in the *Cisco IOS XR Task ID Reference Guide*.
- If you need assistance with your task group assignment, contact your system administrator.
- You must be in a user group associated with a task group that includes the proper task IDs for:
 - BGP commands
 - MPLS commands (generally)
 - MPLS Layer 3 VPN commands
- To configure MPLS Layer 3 VPNs, routers must support MPLS forwarding and Forwarding Information Base (FIB).

The following prerequisites are required for configuring MPLS VPN Inter-AS with autonomous system boundary routers (ASBRs) exchanging VPN-IPV4 addresses or IPv4 routes and MPLS labels:

- Before configuring external Border Gateway Protocol (eBGP) routing between autonomous systems or subautonomous systems in an MPLS VPN, ensure that all MPLS VPN routing instances and sessions are properly configured (see the [How to Implement MPLS Layer 3 VPNs](#), for procedures)
- These following tasks must be performed:
 - Define VPN routing instances
 - Configure BGP routing sessions in the MPLS core

- Configure PE-to-PE routing sessions in the MPLS core
- Configure BGP PE-to-CE routing sessions
- Configure a VPN-IPv4 eBGP session between directly connected ASBRs

MPLS L3VPN Restrictions

The following restrictions apply when configuring MPLS VPN Inter-AS with ASBRs exchanging IPv4 routes and MPLS labels:

- For networks configured with eBGP multihop, a label switched path (LSP) must be configured between non adjacent routers.
- Inter-AS supports IPv4 routes only. IPv6 is not supported.



Note The physical interfaces that connect the BGP speakers must support FIB and MPLS.

The following restrictions apply to routing protocols OSPF and RIP:

- IPv6 is not supported on OSPF and RIP.

Information About MPLS Layer 3 VPNs

To implement MPLS Layer 3 VPNs, you need to understand the following concepts:

MPLS L3VPN Overview

Before defining an MPLS VPN, VPN in general must be defined. A VPN is:

- An IP-based network delivering private network services over a public infrastructure
- A set of sites that are allowed to communicate with each other privately over the Internet or other public or private networks

Conventional VPNs are created by configuring a full mesh of tunnels or permanent virtual circuits (PVCs) to all sites in a VPN. This type of VPN is not easy to maintain or expand, as adding a new site requires changing each edge device in the VPN.

MPLS-based VPNs are created in Layer 3 and are based on the peer model. The peer model enables the service provider and the customer to exchange Layer 3 routing information. The service provider relays the data between the customer sites without customer involvement.

MPLS VPNs are easier to manage and expand than conventional VPNs. When a new site is added to an MPLS VPN, only the edge router of the service provider that provides services to the customer site needs to be updated.

The components of the MPLS VPN are described as follows:

- Provider (P) router—Router in the core of the provider network. PE routers run MPLS switching and do not attach VPN labels to routed packets. VPN labels are used to direct data packets to the correct private network or customer edge router.
- PE router—Router that attaches the VPN label to incoming packets based on the interface or subinterface on which they are received, and also attaches the MPLS core labels. A PE router attaches directly to a CE router.
- Customer (C) router—Router in the Internet service provider (ISP) or enterprise network.
- Customer edge (CE) router—Edge router on the network of the ISP that connects to the PE router on the network. A CE router must interface with a PE router.

The following figure shows a basic MPLS VPN topology.

Figure 27: Basic MPLS VPN Topology

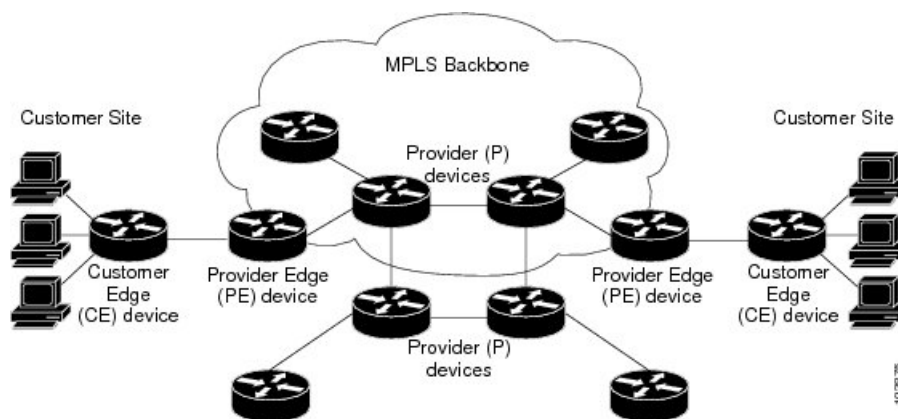

MPLS L3VPN Benefits

MPLS L3VPN provides the following benefits:

- Service providers can deploy scalable VPNs and deliver value-added services.
- Connectionless service guarantees that no prior action is necessary to establish communication between hosts.
- Centralized Service: Building VPNs in Layer 3 permits delivery of targeted services to a group of users represented by a VPN.
- Scalability: Create scalable VPNs using connection-oriented, point-to-point overlays, Frame Relay, or ATM virtual connections.
- Security: Security is provided at the edge of a provider network (ensuring that packets received from a customer are placed on the correct VPN) and in the backbone.
- Integrated Quality of Service (QoS) support: QoS provides the ability to address predictable performance and policy implementation and support for multiple levels of service in an MPLS VPN.
- Straightforward Migration: Service providers can deploy VPN services using a straightforward migration path.

- Migration for the end customer is simplified. There is no requirement to support MPLS on the CE router and no modifications are required for a customer intranet.

How MPLS L3VPN Works

MPLS VPN functionality is enabled at the edge of an MPLS network. The PE router performs the following tasks:

- Exchanges routing updates with the CE router
- Translates the CE routing information into VPN version 4 (VPNv4) and VPN version 6 (VPNv6) routes.
- Exchanges VPNv4 and VPNv6 routes with other PE routers through the Multiprotocol Border Gateway Protocol (MP-BGP)

Virtual Routing and Forwarding Tables

Each VPN is associated with one or more VPN routing and forwarding (VRF) instances. A VRF defines the VPN membership of a customer site attached to a PE router. A VRF consists of the following components:

- An IP version 4 (IPv4) unicast routing table
- A derived FIB table
- A set of interfaces that use the forwarding table
- A set of rules and routing protocol parameters that control the information that is included in the routing table

These components are collectively called a VRF instance.

A one-to-one relationship does not necessarily exist between customer sites and VPNs. A site can be a member of multiple VPNs. However, a site can associate with only one VRF. A VRF contains all the routes available to the site from the VPNs of which it is a member.

Packet forwarding information is stored in the IP routing table and the FIB table for each VRF. A separate set of routing and FIB tables is maintained for each VRF. These tables prevent information from being forwarded outside a VPN and also prevent packets that are outside a VPN from being forwarded to a router within the VPN.

VPN Routing Information: Distribution

The distribution of VPN routing information is controlled through the use of VPN route target communities, implemented by BGP extended communities. VPN routing information is distributed as follows:

- When a VPN route that is learned from a CE router is injected into a BGP, a list of VPN route target extended community attributes is associated with it. Typically, the list of route target community extended values is set from an export list of route targets associated with the VRF from which the route was learned.
- An import list of route target extended communities is associated with each VRF. The import list defines route target extended community attributes that a route must have for the route to be imported into the VRF. For example, if the import list for a particular VRF includes route target extended communities A, B, and C, then any VPN route that carries any of those route target extended communities—A, B, or C—is imported into the VRF.

BGP Distribution of VPN Routing Information

A PE router can learn an IP prefix from the following sources:

- A CE router by static configuration
- An eBGP session with the CE router
- A Routing Information Protocol (RIP) exchange with the CE router
- Open Shortest Path First (OSPF), Enhanced Interior Gateway Routing Protocol (EIGRP), and RIP as Interior Gateway Protocols (IGPs)

The IP prefix is a member of the IPv4 address family. After the PE router learns the IP prefix, the PE converts it into the VPN-IPv4 prefix by combining it with a 64-bit route distinguisher. The generated prefix is a member of the VPN-IPv4 address family. It uniquely identifies the customer address, even if the customer site is using globally nonunique (unregistered private) IP addresses. The route distinguisher used to generate the VPN-IPv4 prefix is specified by the **rd** command associated with the VRF on the PE router.

BGP distributes reachability information for VPN-IPv4 prefixes for each VPN. BGP communication takes place at two levels:

- Within the IP domain, known as an autonomous system.
- Between autonomous systems.

PE to PE or PE to route reflector (RR) sessions are iBGP sessions, and PE to CE sessions are eBGP sessions. PE to CE eBGP sessions can be directly or indirectly connected (eBGP multihop).

BGP propagates reachability information for VPN-IPv4 prefixes among PE routers by the BGP protocol extensions (see RFC 2283, Multiprotocol Extensions for BGP-4), which define support for address families other than IPv4. Using the extensions ensures that the routes for a given VPN are learned only by other members of that VPN, enabling members of the VPN to communicate with each other.

MPLS Forwarding

Based on routing information stored in the VRF IP routing table and the VRF FIB table, packets are forwarded to their destination using MPLS.

A PE router binds a label to each customer prefix learned from a CE router and includes the label in the network reachability information for the prefix that it advertises to other PE routers. When a PE router forwards a packet received from a CE router across the provider network, it labels the packet with the label learned from the destination PE router. When the destination PE router receives the labeled packet, it pops the label and uses it to direct the packet to the correct CE router. Label forwarding across the provider backbone is based on either dynamic label switching or traffic engineered paths. A customer data packet carries two levels of labels when traversing the backbone:

- The top label directs the packet to the correct PE router.
- The second label indicates how that PE router should forward the packet to the CE router.

More labels can be stacked if other features are enabled. For example, if traffic engineering (TE) tunnels with fast reroute (FRR) are enabled, the total number of labels imposed in the PE is four (Layer 3 VPN, Label Distribution Protocol (LDP), TE, and FRR).

Automatic Route Distinguisher Assignment

To take advantage of iBGP load balancing, every network VRF must be assigned a unique route distinguisher. VRF is require a route distinguisher for BGP to distinguish between potentially identical prefixes received from different VPNs.

With thousands of routers in a network each supporting multiple VRFs, configuration and management of route distinguishers across the network can present a problem. Cisco IOS XR software simplifies this process by assigning unique route distinguisher to VRFs using the **rd auto** command.

To assign a unique route distinguisher for each router, you must ensure that each router has a unique BGP router-id. If so, the **rd auto** command assigns a Type 1 route distinguisher to the VRF using the following format: *ip-address:number*. The IP address is specified by the BGP router-id statement and the number (which is derived as an unused index in the 0 to 65535 range) is unique across the VRFs.

Finally, route distinguisher values are checkpointed so that route distinguisher assignment to VRF is persistent across failover or process restart. If an route distinguisher is explicitly configured for a VRF, this value is not overridden by the autoroute distinguisher.

MPLS L3VPN Major Components

An MPLS-based VPN network has three major components:

- VPN route target communities—A VPN route target community is a list of all members of a VPN community. VPN route targets need to be configured for each VPN community member.
- Multiprotocol BGP (MP-BGP) peering of the VPN community PE routers—MP-BGP propagates VRF reachability information to all members of a VPN community. MP-BGP peering needs to be configured in all PE routers within a VPN community.
- MPLS forwarding—MPLS transports all traffic between all VPN community members across a VPN service-provider network.

A one-to-one relationship does not necessarily exist between customer sites and VPNs. A given site can be a member of multiple VPNs. However, a site can associate with only one VRF. A customer-site VRF contains all the routes available to the site from the VPNs of which it is a member

Inter-AS Support for L3VPN

This section contains the following topics:

Inter-AS Restrictions

Inter-AS functionality is available using VPNv4 only. VPNv6 is not currently supported.

Inter-AS Support: Overview

An autonomous system (AS) is a single network or group of networks that is controlled by a common system administration group and uses a single, clearly defined routing protocol.

As VPNs grow, their requirements expand. In some cases, VPNs need to reside on different autonomous systems in different geographic areas. In addition, some VPNs need to extend across multiple service providers (overlapping VPNs). Regardless of the complexity and location of the VPNs, the connection between autonomous systems must be seamless.

An MPLS VPN Inter-AS provides the following benefits:

- Allows a VPN to cross more than one service provider backbone.

Service providers, running separate autonomous systems, can jointly offer MPLS VPN services to the same end customer. A VPN can begin at one customer site and traverse different VPN service provider backbones before arriving at another site of the same customer. Previously, MPLS VPN could traverse only a single BGP autonomous system service provider backbone. This feature lets multiple autonomous systems form a continuous, seamless network between customer sites of a service provider.

- Allows a VPN to exist in different areas.

A service provider can create a VPN in different geographic areas. Having all VPN traffic flow through one point (between the areas) allows for better rate control of network traffic between the areas.

- Allows confederations to optimize iBGP meshing.

Internal Border Gateway Protocol (iBGP) meshing in an autonomous system is more organized and manageable. You can divide an autonomous system into multiple, separate subautonomous systems and then classify them into a single confederation. This capability lets a service provider offer MPLS VPNs across the confederation, as it supports the exchange of labeled VPN-IPv4 Network Layer Reachability Information (NLRI) between the subautonomous systems that form the confederation.

Inter-AS and ASBRs

Separate autonomous systems from different service providers can communicate by exchanging IPv4 NLRI and IPv6 in the form of VPN-IPv4 addresses. The ASBRs use eBGP to exchange that information. Then an Interior Gateway Protocol (IGP) distributes the network layer information for VPN-IPv4 prefixes throughout each VPN and each autonomous system. The following protocols are used for sharing routing information:

- Within an autonomous system, routing information is shared using an IGP.
- Between autonomous systems, routing information is shared using an eBGP. An eBGP lets service providers set up an interdomain routing system that guarantees the loop-free exchange of routing information between separate autonomous systems.

The primary function of an eBGP is to exchange network reachability information between autonomous systems, including information about the list of autonomous system routes. The autonomous systems use EBGP border edge routers to distribute the routes, which include label switching information. Each border edge router rewrites the next-hop and MPLS labels.

Inter-AS configurations supported in an MPLS VPN can include:

- Interprovider VPN—MPLS VPNs that include two or more autonomous systems, connected by separate border edge routers. The autonomous systems exchange routes using eBGP. No IGP or routing information is exchanged between the autonomous systems.
- BGP Confederations—MPLS VPNs that divide a single autonomous system into multiple subautonomous systems and classify them as a single, designated confederation. The network recognizes the confederation as a single autonomous system. The peers in the different autonomous

systems communicate over eBGP sessions; however, they can exchange route information as if they were iBGP peers.

Transmitting Information Between Autonomous Systems

The following figure illustrates one MPLS VPN consisting of two separate autonomous systems. Each autonomous system operates under different administrative control and runs a different IGP. Service providers exchange routing information through eBGP border edge routers (ASBR1 and ASBR2).

Figure 28: eBGP Connection Between Two MPLS VPN Inter-AS Systems with ASBRs Exchanging VPN-IPv4 Addresses

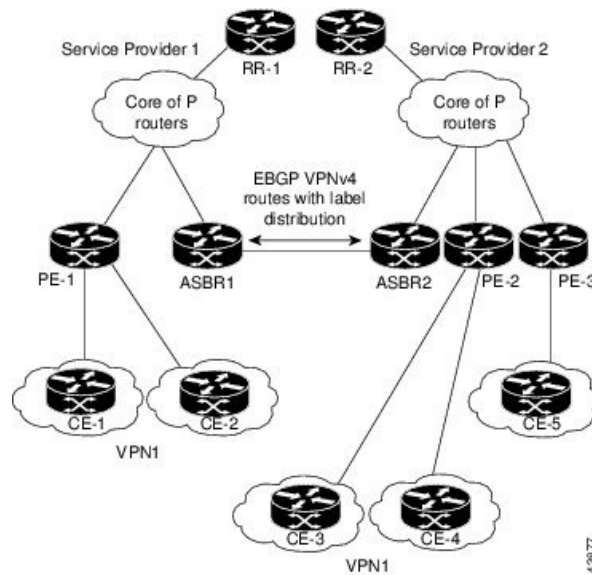

This configuration uses the following process to transmit information:

1. The provider edge router (PE-1) assigns a label for a route before distributing that route. The PE router uses the multiprotocol extensions of BGP to transmit label mapping information. The PE router distributes the route as a VPN-IPv4 address. The address label and the VPN identifier are encoded as part of the NLRI.
2. The two route reflectors (RR-1 and RR-2) reflect VPN-IPv4 internal routes within the autonomous system. The border edge routers of the autonomous system (ASBR1 and ASBR2) advertise the VPN-IPv4 external routes.
3. The eBGP border edge router (ASBR1) redistributes the route to the next autonomous system (ASBR2). ASBR1 specifies its own address as the value of the eBGP next-hop attribute and assigns a new label. The address ensures:
 - That the next-hop router is always reachable in the service provider (P) backbone network.
 - That the label assigned by the distributing router is properly interpreted. (The label associated with a route must be assigned by the corresponding next-hop router.)
4. The eBGP border edge router (ASBR2) redistributes the route in one of the following ways, depending on the configuration:

- If the iBGP neighbors are configured with the **next-hop-self** command, ASBR2 changes the next-hop address of updates received from the eBGP peer, then forwards it.
- If the iBGP neighbors are not configured with the **next-hop-self** command, the next-hop address does not get changed. ASBR2 must propagate a host route for the eBGP peer through the IGP. To propagate the eBGP VPN-IPv4 neighbor host route, use the **redistribute** command with the **static** keyword. An eBGP VPN-IPv4 neighbor host route must be manually configured to establish the LSP towards ASBR1. The static route needs to be redistributed to IGP, to let other PE routers use the /32 host prefix label to forward traffic for an Inter-AS VPN redistribute static option.



Note This option is not supported for Inter-AS over IP tunnels.

Exchanging VPN Routing Information

Autonomous systems exchange VPN routing information (routes and labels) to establish connections. To control connections between autonomous systems, the PE routers and eBGP border edge routers maintain a label forwarding information base (LFIB). The LFIB manages the labels and routes that the PE routers and eBGP border edge routers receive during the exchange of VPN information.

The autonomous systems use the following guidelines to exchange VPN routing information:

- Routing information includes:
 - The destination network (N)
 - The next-hop field associated with the distributing router
 - A local MPLS label (L)
- A route distinguisher (RD1). A route distinguisher is part of a destination network address. It makes the VPN-IPv4 route globally unique in the VPN service provider environment.
- The ASBRs are configured to change the next-hop when sending VPN-IPv4 NLRI to the iBGP neighbors. Therefore, the ASBRs must allocate a new label when they forward the NLRI to the iBGP neighbors.

Figure 29: Exchanging Routes and Labels Between MPLS VPN Inter-AS Systems with ASBRs Exchanging VPN-IPv4 Address

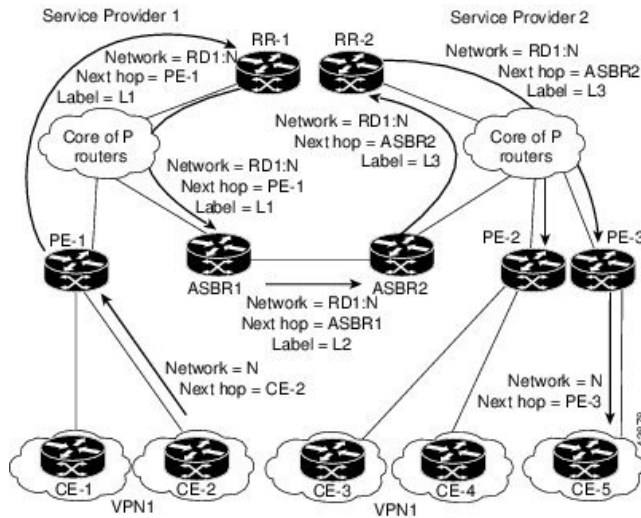

The following figure illustrates the exchange of VPN route and label information between autonomous systems. The only difference is that ASBR2 is configured with the **redistribute** command with the **connected** keyword, which propagates the host routes to all PEs. The command is necessary as ASBR2 is not configured to change the next-hop address.



Note The following figure is not applicable to Inter-AS over IP tunnels.

Figure 30: Exchanging Routes and Labels with the redistributed Command in an MPLS VPN Inter-AS with ASBRs Exchanging VPN-IPv4 Addresses

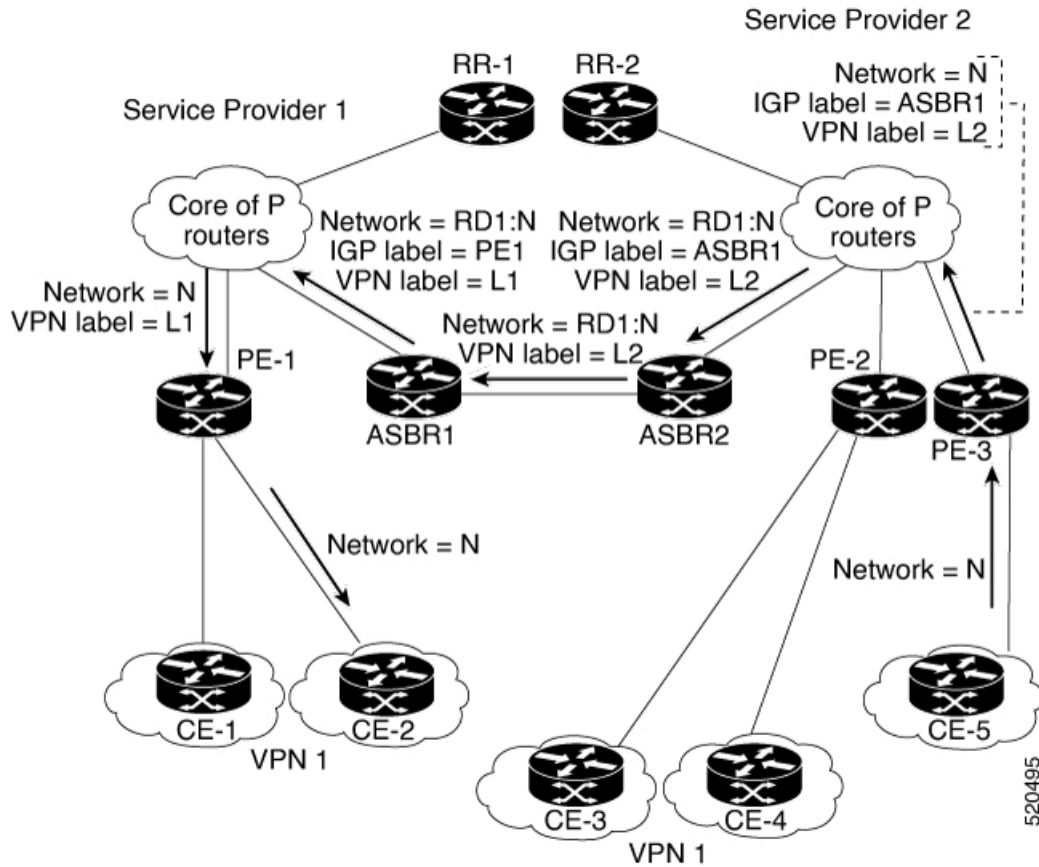

Packet Forwarding



Note This section is not applicable to Inter-AS over IP tunnels.

The figure below illustrates how packets are forwarded between autonomous systems in an interprovider network using the following packet method.

Packets are forwarded to their destination by means of MPLS. Packets use the routing information stored in the LFIB of each PE router and eBGP border edge router.

The service provider VPN backbone uses dynamic label switching to forward labels.

Each autonomous system uses standard multilevel labeling to forward packets between the edges of the autonomous system routers (for example, from CE-5 to PE-3). Between autonomous systems, only a single level of labeling is used, corresponding to the advertised route.

A data packet carries two levels of labels when traversing the VPN backbone:

- The first label (IGP route label) directs the packet to the correct PE router on the eBGP border edge router. (For example, the IGP label of ASBR2 points to the ASBR2 border edge router.)

- The second label (VPN route label) directs the packet to the appropriate PE router or eBGP border edge router.

Figure 31: Forwarding Packets Between MPLS VPN Inter-AS Systems with ASBRs Exchanging VPN-IPv4 Addresses

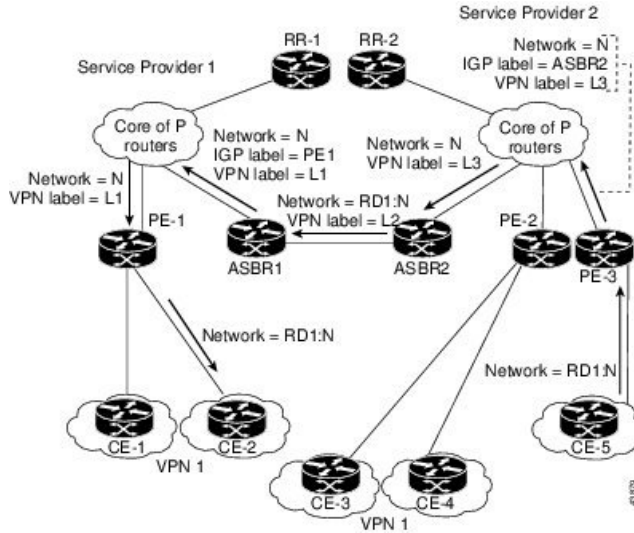

The following figure shows the same packet forwarding method, except the eBGP router (ASBR1) forwards the packet without reassigning a new label to it.

Figure 32: Forwarding Packets Without a New Label Assignment Between MPLS VPN Inter-AS System with ASBRs Exchanging VPN-IPv4 Addresses

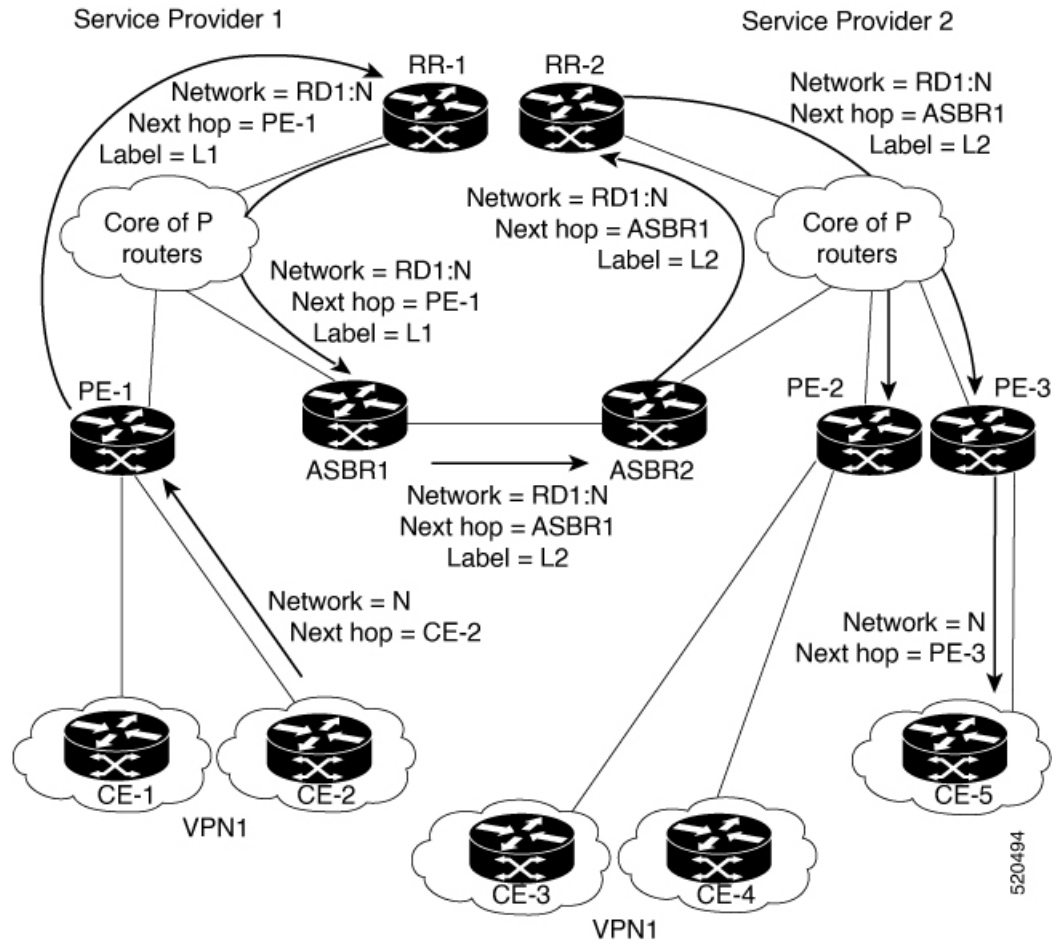

The following figure illustrates the exchange of VPN route and label information between autonomous systems.

Figure 33: Exchanging Routes and Labels in an MPLS VPN Inter-AS with ASBRs

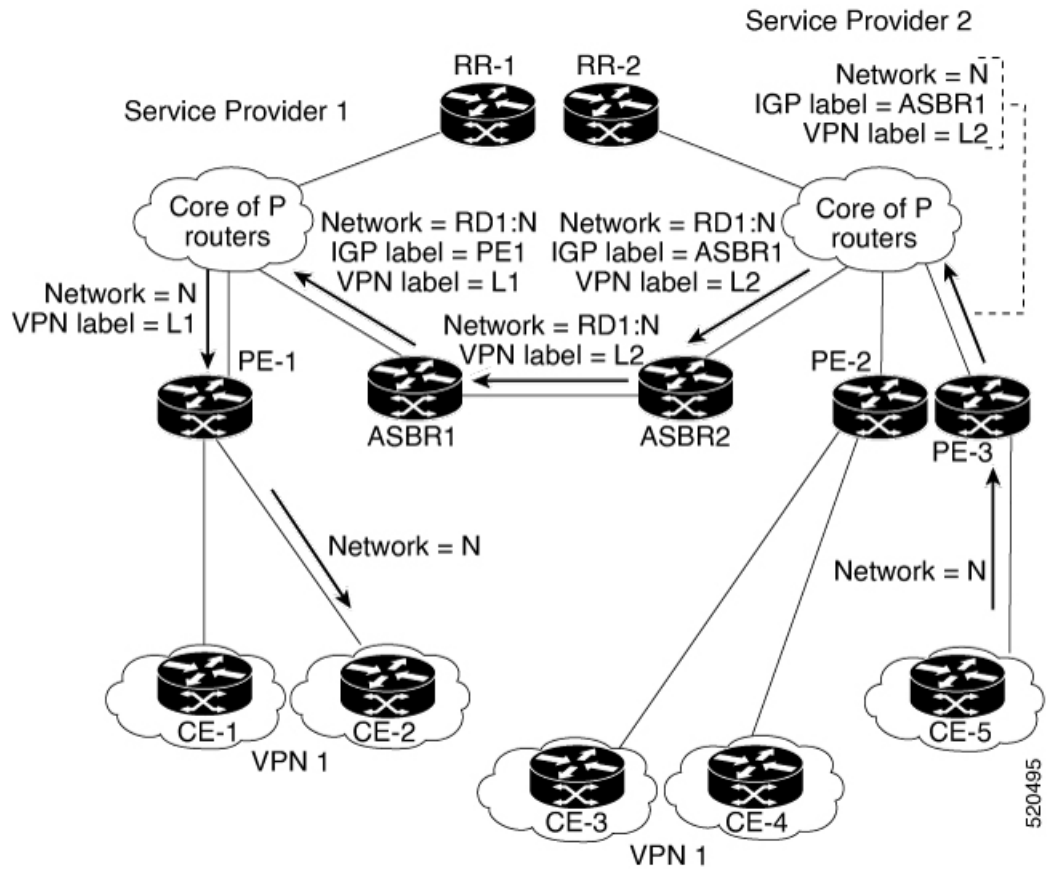

Confederations

A confederation is multiple subautonomous systems grouped together. A confederation reduces the total number of peer devices in an autonomous system. A confederation divides an autonomous system into subautonomous systems and assigns a confederation identifier to the autonomous systems. A VPN can span service providers running in separate autonomous systems or multiple subautonomous systems that form a confederation.

In a confederation, each subautonomous system is fully meshed with other subautonomous systems. The subautonomous systems communicate using an IGP, such as Open Shortest Path First (OSPF) or Intermediate System-to-Intermediate System (IS-IS). Each subautonomous system also has an eBGP connection to the other subautonomous systems. The confederation eBGP (CEBGP) border edge routers forward next-hop-self addresses between the specified subautonomous systems. The next-hop-self address forces the BGP to use a specified address as the next hop rather than letting the protocol choose the next hop.

You can configure a confederation with separate subautonomous systems two ways:

- Configure a router to forward next-hop-self addresses between only the CEBGP border edge routers (both directions). The subautonomous systems (iBGP peers) at the subautonomous system border do not forward the next-hop-self address. Each subautonomous system runs as a single IGP domain. However, the CEBGP border edge router addresses are known in the IGP domains.

- Configure a router to forward next-hop-self addresses between the CEBGP border edge routers (both directions) and within the iBGP peers at the subautonomous system border. Each subautonomous system runs as a single IGP domain but also forwards next-hop-self addresses between the PE routers in the domain. The CEBGP border edge router addresses are known in the IGP domains.



Note eBGP Connection Between Two Subautonomous Systems in a Confederation figure illustrates how two autonomous systems exchange routes and forward packets. Subautonomous systems in a confederation use a similar method of exchanging routes and forwarding packets.

The figure below illustrates a typical MPLS VPN confederation configuration. In this configuration:

- The two CEBGP border edge routers exchange VPN-IPv4 addresses with labels between the two autonomous systems.
- The distributing router changes the next-hop addresses and labels and uses a next-hop-self address.
- IGP-1 and IGP-2 know the addresses of CEBGP-1 and CEBGP-2.

Figure 34: eBGP Connection Between Two Subautonomous Systems in a Confederation

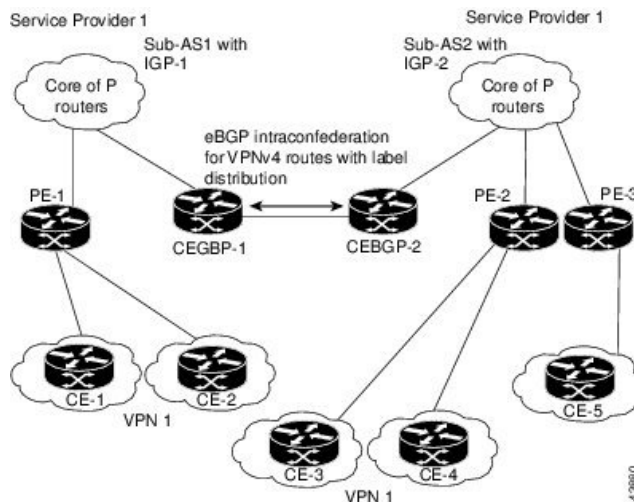

In this confederation configuration:

- CEBGP border edge routers function as neighboring peers between the subautonomous systems. The subautonomous systems use eBGP to exchange route information.
- Each CEBGP border edge router (CEBGP-1 and CEBGP-2) assigns a label for the router before distributing the route to the next subautonomous system. The CEBGP border edge router distributes the route as a VPN-IPv4 address by using the multiprotocol extensions of BGP. The label and the VPN identifier are encoded as part of the NLRI.
- Each PE and CEBGP border edge router assigns its own label to each VPN-IPv4 address prefix before redistributing the routes. The CEBGP border edge routers exchange IPV-IPv4 addresses with the labels. The next-hop-self address is included in the label (as the value of the eBGP next-hop attribute). Within the subautonomous systems, the CEBGP border edge router address is distributed throughout the iBGP neighbors, and the two CEBGP border edge routers are known to both confederations.

- For more information about how to configure confederations, see the .

MPLS VPN Inter-AS BGP Label Distribution



Note This section is not applicable to Inter-AS over IP tunnels.

You can set up the MPLS VPN Inter-AS network so that the ASBRs exchange IPv4 routes with MPLS labels of the provider edge (PE) routers. Route reflectors (RRs) exchange VPN-IPv4 routes by using multihop, multiprotocol external Border Gateway Protocol (eBGP). This method of configuring the Inter-AS system is often called MPLS VPN Inter-AS BGP Label Distribution.

Configuring the Inter-AS system so that the ASBRs exchange the IPv4 routes and MPLS labels has the following benefits:

- Saves the ASBRs from having to store all the VPN-IPv4 routes. Using the route reflectors to store the VPN-IPv4 routes and distributes them to the PE routers results in improved scalability compared with configurations in which the ASBR holds all the VPN-IPv4 routes and distributes the routes based on VPN-IPv4 labels.
- Having the route reflectors hold the VPN-IPv4 routes also simplifies the configuration at the border of the network.
- Enables a non-VPN core network to act as a transit network for VPN traffic. You can transport IPv4 routes with MPLS labels over a non-MPLS VPN service provider.
- Eliminates the need for any other label distribution protocol between adjacent label switch routers (LSRs). If two adjacent LSRs are also BGP peers, BGP can handle the distribution of the MPLS labels. No other label distribution protocol is needed between the two LSRs.

Exchanging IPv4 Routes with MPLS labels



Note This section is not applicable to Inter-AS over IP tunnels.

You can set up a VPN service provider network to exchange IPv4 routes with MPLS labels. You can configure the VPN service provider network as follows:

- Route reflectors exchange VPN-IPv4 routes by using multihop, multiprotocol eBGP. This configuration also preserves the next-hop information and the VPN labels across the autonomous systems.
- A local PE router (for example, PE1 in the figure below) needs to know the routes and label information for the remote PE router (PE2).

This information can be exchanged between the PE routers and ASBRs in one of two ways:

- Internal Gateway Protocol (IGP) and Label Distribution Protocol (LDP): The ASBR can redistribute the IPv4 routes and MPLS labels it learned from eBGP into IGP and LDP and from IGP and LDP into eBGP.

- Internal Border Gateway Protocol (iBGP) IPv4 label distribution: The ASBR and PE router can use direct iBGP sessions to exchange VPN-IPv4 and IPv4 routes and MPLS labels.

Alternatively, the route reflector can reflect the IPv4 routes and MPLS labels learned from the ASBR to the PE routers in the VPN. This reflecting of learned IPv4 routes and MPLS labels is accomplished by enabling the ASBR to exchange IPv4 routes and MPLS labels with the route reflector. The route reflector also reflects the VPN-IPv4 routes to the PE routers in the VPN. For example, in VPN1, RR1 reflects to PE1 the VPN-IPv4 routes it learned and IPv4 routes and MPLS labels learned from ASBR1. Using the route reflectors to store the VPN-IPv4 routes and forward them through the PE routers and ASBRs allows for a scalable configuration.

Figure 35: VPNs Using eBGP and iBGP to Distribute Routes and MPLS Labels

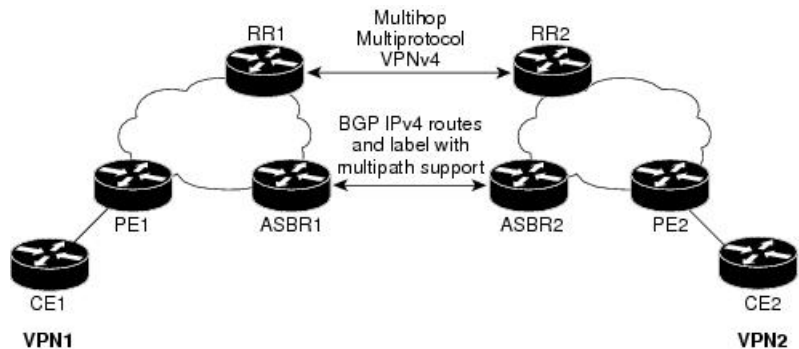

BGP Routing Information

BGP routing information includes the following items:

- Network number (prefix), which is the IP address of the destination.
- Autonomous system (AS) path, which is a list of the other ASs through which a route passes on the way to the local router. The first AS in the list is closest to the local router; the last AS in the list is farthest from the local router and usually the AS where the route began.
- Path attributes, which provide other information about the AS path, for example, the next hop.

BGP Messages and MPLS Labels

MPLS labels are included in the update messages that a router sends. Routers exchange the following types of BGP messages:

- Open messages—After a router establishes a TCP connection with a neighboring router, the routers exchange open messages. This message contains the number of the autonomous system to which the router belongs and the IP address of the router that sent the message.
- Update messages—When a router has a new, changed, or broken route, it sends an update message to the neighboring router. This message contains the NLRI, which lists the IP addresses of the usable routes. The update message includes any routes that are no longer usable. The update message also includes path attributes and the lengths of both the usable and unusable paths. Labels for VPN-IPv4 routes are encoded in the update message, as specified in RFC 2858. The labels for the IPv4 routes are encoded in the update message, as specified in RFC 3107.
- Keepalive messages—Routers exchange keepalive messages to determine if a neighboring router is still available to exchange routing information. The router sends these messages at regular intervals. (Sixty

seconds is the default for Cisco routers.) The keepalive message does not contain routing data; it contains only a message header.

- Notification messages—When a router detects an error, it sends a notification message.

Sending MPLS Labels with Routes

When BGP (eBGP and iBGP) distributes a route, it can also distribute an MPLS label that is mapped to that route. The MPLS label mapping information for the route is carried in the BGP update message that contains the information about the route. If the next hop is not changed, the label is preserved.

When you issue the **show bgp neighbors ip-address** command on both BGP routers, the routers advertise to each other that they can then send MPLS labels with the routes. If the routers successfully negotiate their ability to send MPLS labels, the routers add MPLS labels to all outgoing BGP updates.

Generic Routing Encapsulation Support for L3VPN

Generic Routing Encapsulation (GRE) is a tunneling protocol that can encapsulate many types of packets to enable data transmission using a tunnel. The GRE tunneling protocol enables:

- High assurance Internet Protocol encryptor (HAiPE) devices for encryption over the public Internet and nonsecure connections.
- Service providers (that do not run MPLS in their core network) to provide VPN services along with the security services.

GRE is used with IP to create a virtual point-to-point link to routers at remote points in a network. For detailed information about configuring GRE tunnel interfaces, see the <module-name> module of the Cisco IOS XR Interfaces and Hardware Components Configuration Guide.



Note For a PE to PE (core) link, enable LDP (with implicit null) on the GRE interfaces for L3VPN.

GRE Restriction for L3VPN

The following restrictions are applicable to L3VPN forwarding over GRE:

- Carrier Supporting Carrier (CsC) or Inter-AS is not supported.
- GRE-based L3VPN does not interwork with MPLS or IP VPNs.
- GRE tunnel is supported only as a core link (PE-PE, PE-P, P-P, P-PE). A PE-CE (edge) link is not supported.
- VPNv6 forwarding using GRE tunnels is not supported.

VPNv4 Forwarding Using GRE Tunnels

This section describes the working of VPNv4 forwarding over GRE tunnels. The following description assumes that GRE is used only as a core link between the encapsulation and decapsulation provider edge (PE) routers that are connected to one or more customer edge (CE) routers.

Ingress of Encapsulation Router

On receiving prefixes from the CE routers, Border Gateway Protocol (BGP) assigns the VPN label to the prefixes that need to be exported. These VPN prefixes are then forwarded to the Forwarding Information Base (FIB) using the Route Information Base (RIB) or the label switched database (LSD). The FIB then populates the prefix in the appropriate VRF table. The FIB also populates the label in the global label table. Using BGP, the prefixes are then relayed to the remote PE router (decapsulation router).

Egress of Encapsulation Router

The forwarding behavior on egress of the encapsulation PE router is similar to the MPLS VPN label imposition. Regardless of whether the VPN label imposition is performed on the ingress or egress side, the GRE tunnel forwards a packet that has an associated label. This labeled packet is then encapsulated with a GRE header and forwarded based on the IP header.

Ingress of Decapsulation Router

The decapsulation PE router learns the VPN prefixes and label information from the remote encapsulation PE router using BGP. The next-hop information for the VPN prefix is the address of the GRE tunnel interface connecting the two PE routers. BGP downloads these prefixes to the RIB. The RIB downloads the routes to the FIB and the FIB installs the routes in the hardware.

Egress of Decapsulation Router

The egress forwarding behavior on the decapsulation PE router is similar to VPN disposition and forwarding, based on the protocol type of the inner payload.

Carrier Supporting Carrier Support for L3VPN

This section provides conceptual information about MPLS VPN Carrier Supporting Carrier (CSC) functionality and includes the following topics:

- [CSC Prerequisites](#)
- [CSC Benefits](#)
- [Configuration Options for the Backbone and Customer Carriers](#)

Throughout this document, the following terminology is used in the context of CSC:

backbone carrier—Service provider that provides the segment of the backbone network to the other provider. A backbone carrier offers BGP and MPLS VPN services.

customer carrier—Service provider that uses the segment of the backbone network. The customer carrier may be an Internet service provider (ISP) or a BGP/MPLS VPN service provider.

CE router—A customer edge router is part of a customer network and interfaces to a provider edge (PE) router. In this document, the CE router sits on the edge of the customer carrier network.

PE router—A provider edge router is part of a service provider's network connected to a customer edge (CE) router. In this document, the PE router sits on the edge of the backbone carrier network

ASBR—An autonomous system boundary router connects one autonomous system to another.

CSC Prerequisites

The following prerequisites are required to configure CSC:

- You must be able to configure MPLS VPNs with end-to-end (CE-to-CE router) pings working.
- You must be able to configure Interior Gateway Protocols (IGPs), MPLS Label Distribution Protocol (LDP), and Multiprotocol Border Gateway Protocol (MP-BGP).
- You must ensure that CSC-PE and CSC-CE routers support BGP label distribution.



Note BGP is the only supported label distribution protocol on the link between CE and PE.

CSC Benefits

This section describes the benefits of CSC to the backbone carrier and customer carriers.

Benefits to the Backbone Carrier

- The backbone carrier can accommodate many customer carriers and give them access to its backbone.
- The MPLS VPN carrier supporting carrier feature is scalable.
- The MPLS VPN carrier supporting carrier feature is a flexible solution.

Benefits to the Customer Carriers

- The MPLS VPN carrier supporting carrier feature removes from the customer carrier the burden of configuring, operating, and maintaining its own backbone.
- Customer carriers who use the VPN services provided by the backbone carrier receive the same level of security that Frame Relay or ATM-based VPNs provide.
- Customer carriers can use any link layer technology to connect the CE routers to the PE routers and the PE routers to the P routers.
- The customer carrier can use any addressing scheme and still be supported by a backbone carrier.

Benefits of Implementing MPLS VPN CSC Using BGP

The benefits of using BGP to distribute IPv4 routes and MPLS label routes are:

- BGP takes the place of an IGP and LDP in a VPN forwarding and routing instance (VRF) table.
- BGP is the preferred routing protocol for connecting two ISPs.

Configuration Options for the Backbone and Customer Carriers

To enable CSC, the backbone and customer carriers must be configured accordingly:

- The backbone carrier must offer BGP and MPLS VPN services.

- The customer carrier can take several networking forms. The customer carrier can be:
 - An ISP with an IP core (see the “[Customer Carrier: ISP with IP Core](#)”).
 - An MPLS service provider with or without VPN services (see “[Customer Carrier: MPLS Service Provider](#)”).



Note An IGP in the customer carrier network is used to distribute next hops and loopbacks to the CSC-CE. IBGP with label sessions are used in the customer carrier network to distribute next hops and loopbacks to the CSC-CE.

Customer Carrier: ISP with IP Core

The following figure shows a network configuration where the customer carrier is an ISP. The customer carrier has two sites, each of which is a point of presence (POP). The customer carrier connects these sites using a VPN service provided by the backbone carrier. The backbone carrier uses MPLS or IP tunnels to provide VPN services. The ISP sites use IP.

Figure 36: Network: Customer Carrier Is an ISP

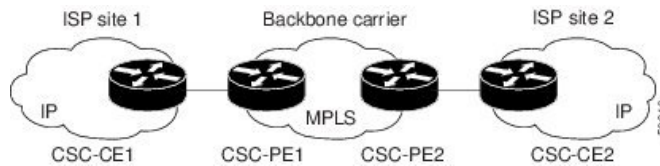

The links between the CE and PE routers use eBGP to distribute IPv4 routes and MPLS labels. Between the links, the PE routers use multiprotocol iBGP to distribute VPNv4 routes.

Customer Carrier: MPLS Service Provider

The following figure shows a network configuration where the backbone carrier and the customer carrier are BGP/MPLS VPN service providers. The customer carrier has two sites. The customer carrier uses MPLS in its network while the backbone carrier may use MPLS or IP tunnels in its network.

Figure 37: Network: Customer Carrier Is an MPLS VPN Service Provider

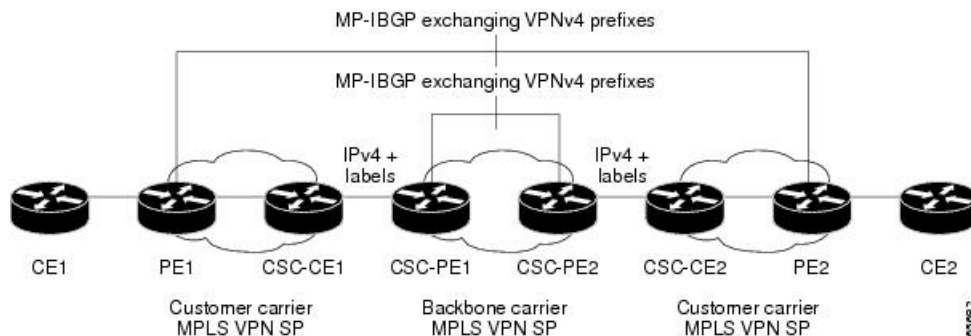

In Network: Customer Carrier Is an MPLS VPN Service Provider configuration, the customer carrier can configure its network in one of these ways:

- The customer carrier can run an IGP and LDP in its core network. In this case, the CSC-CE1 router in the customer carrier redistributes the eBGP routes it learns from the CSC-PE1 router of the backbone carrier to an IGP
- The CSC-CE1 router of the customer carrier system can run an IPv4 and labels iBGP session with the PE1 router.

IPv6 VPN Provider Edge (6VPE) Support

6VPE uses the existing MPLS IPv4 core infrastructure for IPv6 transports to enable IPv6 sites to communicate over an MPLS IPv4 core network using MPLS label switch paths (LSPs). 6VPE relies on multiprotocol BGP extensions in the IPv4 network configuration on the provider edge (PE) router to exchange IPv6 reachability information. Edge routers are then configured to be dual stacks running both IPv4 and IPv6, and use the IPv4 mapped IPv6 address for IPv6 prefix reachability exchange, see [“Dual Stack”](#).

This section includes the follow subsections:

6VPE Benefits

6VPE provides the following benefits to service providers:

- Support for IPv6 without changing the IPv4 MPLS backbone.
- No requirement for a separate signaling plane.
- Leverages operational IPv4 MPLS backbones.
- Cost savings from operating expenses.
- Addresses the security limitations of 6PE.
- Provides logically-separate routing table entries for VPN member devices.
- Provides support for Inter-AS and CSC scenarios. Inter-AS support for 6VPE requires support of Border Gateway Protocol (BGP) to enable the address families and to allocate and distribute the PE and ASBR labels.

6VPE Network Architecture

The following figure illustrates the 6VPE network architecture and control plane protocols when two IPv6 sites communicate through an MPLSv4 backbone.

Figure 38: 6VPE Network Architecture

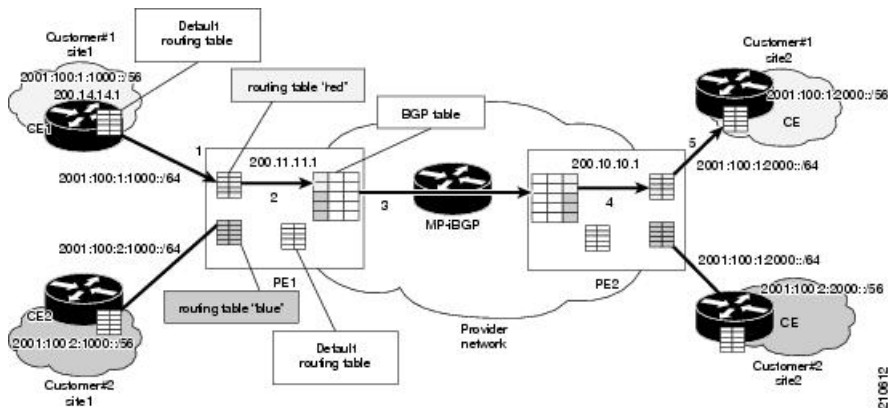

Dual Stack

Dual stack is a technique that lets IPv4 and IPv6 coexist on the same interfaces. Coexistence of IPv4 and IPv6 is a requirement for initial deployment. With regard to supporting IPv6 on a MPLS network, two important aspects of the network should be reviewed:

- **Core:** The 6VPE technique carries IPv6 in a VPN fashion over a non-IPv6-aware MPLS core, and enables IPv4 or IPv6 communities to communicate with each other over an IPv4 MPLS backbone without modifying the core infrastructure. By avoiding dual stacking on the core routers, the resources can be dedicated to their primary function to avoid any complexity on the operational side. The transition and integration with respect to the current state of networks is also transparent.
- **Access:** To support native IPv6, the access that connects to IPv4 and IPv6 domains must be IPv6-aware. Service provider edge elements can exchange routing information with end users; therefore, dual stacking is a mandatory requirement on the access layer.

6VPE Operation

When IPv6 is enabled on the subinterface that is participating in a VPN, it becomes an IPv6 VPN. The customer edge-provider edge link is running IPv6 or IPv4 natively. The addition of IPv6 on a provider edge router turns the provider edge into 6VPE, thereby enabling service providers to support IPv6 over the MPLS network.

Provider edge routers use VRF tables to maintain the segregated reachability and forwarding information of each IPv6 VPN. MPBGP with its IPv6 extensions distributes the routes from 6VPE to other 6VPEs through a direct IBGP session or through VPNv6 route reflectors. The next hop of the advertising provider edge router still remains the IPv4 address (normally it is a loopback interface), but with the addition of IPv6, a value of `::FFFF:` is prepended to the IPv4 next hop.



Note Multiple VRFs on the same physical or logical interface are not supported. Only one VRF, which is used for both IPv4 and IPv6 address families, is supported.

The technique can be best described as automatic tunneling of the IPv6 packets through the IPv4 backbone. The MP-BGP relationships remain the same as they are for VPNv4 traffic, with an additional capability of VPNv6. Where both IPv4 and IPv6 are supported, the same set of MPBGP peering relationships is used.

To summarize, from the control plane perspective, the prefixes are signaled across the backbone in the same way as regular MPLS and VPN prefix advertisements. The top label represents the IGP information that remains the same as for IPv4 MPLS. The bottom label represents the VPN information that the packet belongs to. As described earlier, additionally the MPBGP next hop is updated to make it IPv6-compliant. The forwarding or data plane function remains the same as it is deployed for the IPv4 MPLS VPN. The packet forwarding of IPv4 on the current MPLS VPN remains intact.

For detailed information on commands used to configure 6VPE over MPLS, see *Cisco IOS XR MPLS Configuration Guide*.

How to Implement MPLS Layer 3 VPNs

This section contains instructions for the following tasks:

Configuring the Core Network

Configuring the core network includes the following tasks:

Assessing the Needs of MPLS VPN Customers

Before configuring an MPLS VPN, the core network topology must be identified so that it can best serve MPLS VPN customers. Perform this task to identify the core network topology.

SUMMARY STEPS

1. Identify the size of the network.
2. Identify the routing protocols in the core.
3. Determine if MPLS High Availability support is required.
4. Determine if BGP load sharing and redundant paths are required.

DETAILED STEPS

-
- Step 1** Identify the size of the network.
- Identify the following to determine the number of routers and ports required:
- How many customers will be supported?
 - How many VPNs are required for each customer?
 - How many virtual routing and forwarding (VRF) instances are there for each VPN?
- Step 2** Identify the routing protocols in the core.
- Determine which routing protocols are required in the core network.
- Step 3** Determine if MPLS High Availability support is required.
- MPLS VPN nonstop forwarding and graceful restart are supported on select routers and Cisco IOS XR software releases.
- Step 4** Determine if BGP load sharing and redundant paths are required.

Determine if BGP load sharing and redundant paths in the MPLS VPN core are required.

Configuring Routing Protocols in the Core

To configure a routing protocol, see the .

Configuring MPLS in the Core

To enable MPLS on all routers in the core, you must configure a Label Distribution Protocol (LDP). You can use either of the following as an LDP:

- MPLS LDP—See the *Implementing MPLS Label Distribution Protocol* chapter in the *MPLS Configuration Guide for the Cisco CRS Routers* for configuration information.
- MPLS Traffic Engineering Resource Reservation Protocol (RSVP)—See *Implementing RSVP for MPLS-TE and MPLS O-UNI* module in the *MPLS Configuration Guide for the Cisco CRS Routers* for configuration information.

Determining if FIB Is Enabled in the Core

Forwarding Information Base (FIB) must be enabled on all routers in the core, including the provider edge (PE) routers. For information on how to determine if FIB is enabled, see the *Implementing Cisco Express Forwarding* module in the *IP Addresses and Services Configuration Guide for Cisco CRS Routers*.

Configuring Multiprotocol BGP on the PE Routers and Route Reflectors

Perform this task to configure multiprotocol BGP (MP-BGP) connectivity on the PE routers and route reflectors.

SUMMARY STEPS

1. **configure**
2. **router bgp** *autonomous-system-number*
3. **address-family vpnv4 unicast** or **address-family vpnv6 unicast**
4. **neighbor ip-address remote-as** *autonomous-system-number*
5. **address-family vpnv4 unicast** or **address-family vpnv6 unicast**
6. Use the **commit** or **end** command.

DETAILED STEPS

Step 1 **configure**

Example:

```
RP/0/RP0/CPU0:router# configure
```

Enters the Global Configuration mode.

Step 2 **router bgp** *autonomous-system-number*

Example:

```
RP/0/RP0/CPU0:router(config)# router bgp 120
```

Enters BGP configuration mode allowing you to configure the BGP routing process.

Step 3 **address-family vpnv4 unicast** or **address-family vpnv6 unicast**

Example:

```
RP/0/RP0/CPU0:router(config-bgp)# address-family vpnv4 unicast
```

Enters VPNv4 or VPNv6 address family configuration mode for the VPNv4 or VPNv6 address family.

Step 4 **neighbor ip-address remote-as autonomous-system-number**

Example:

```
RP/0/RP0/CPU0:router(config-bgp)# neighbor 172.168.40.24 remote-as 2002
```

Creates a neighbor and assigns it a remote autonomous system number.

Step 5 **address-family vpnv4 unicast** or **address-family vpnv6 unicast**

Example:

```
RP/0/RP0/CPU0:router(config-bgp-nbr)# address-family vpnv4 unicast
```

Enters VPNv4 or VPNv6 address family configuration mode for the VPNv4 or VPNv6 address family.

Step 6 Use the **commit** or **end** command.

commit - Saves the configuration changes and remains within the configuration session.

end - Prompts user to take one of these actions:

- **Yes** - Saves configuration changes and exits the configuration session.
- **No** - Exits the configuration session without committing the configuration changes.
- **Cancel** - Remains in the configuration mode, without committing the configuration changes.

Connecting MPLS VPN Customers

To connect MPLS VPN customers to the VPN, perform the following tasks:

Defining VRFs on the PE Routers to Enable Customer Connectivity

Perform this task to define VPN routing and forwarding (VRF) instances.

SUMMARY STEPS

1. **configure**
2. **vrf vrf-name**
3. **address-family ipv4 unicast**

4. **import route-policy** *policy-name*
5. **import route-target** [*as-number:nn* | *ip-address:nn*]
6. **export route-policy** *policy-name*
7. **export route-target** [*as-number:nn* | *ip-address:nn*]
8. **exit**
9. **exit**
10. **router bgp** *autonomous-system-number*
11. **vrf** *vrf-name*
12. **rd** { *as-number* | *ip-address* | **auto** }
13. Use the **commit** or **end** command.

DETAILED STEPS

Step 1 **configure**

Example:

```
RP/0/RP0/CPU0:router# configure
Enters Global Configuration mode.
```

Step 2 **vrf** *vrf-name*

Example:

```
RP/0/RP0/CPU0:router(config)# vrf vrf_1

Configures a VRF instance and enters VRF configuration mode.
```

Step 3 **address-family ipv4 unicast**

Example:

```
RP/0/RP0/CPU0:router(config-vrf)# address-family ipv4 unicast

Enters VRF address family configuration mode for the IPv4 address family.
```

Step 4 **import route-policy** *policy-name*

Example:

```
RP/0/RP0/CPU0:router(config-vrf-af)# import route-policy policy_A

Specifies a route policy that can be imported into the local VPN.
```

Step 5 **import route-target** [*as-number:nn* | *ip-address:nn*]

Example:

```
RP/0/RP0/CPU0:router(config-vrf-af)# import route-target 120:1
```

Allows exported VPN routes to be imported into the VPN if one of the route targets of the exported route matches one of the local VPN import route targets.

Step 6 **export route-policy** *policy-name*

Example:

```
RP/0/RP0/CPU0:router(config-vrf-af)# export route-policy policy_B
```

Specifies a route policy that can be exported from the local VPN.

Step 7 **export route-target** [*as-number:nn* | *ip-address:nn*]

Example:

```
RP/0/RP0/CPU0:router(config-vrf-af)# export route-target 120:2
```

Associates the local VPN with a route target. When the route is advertised to other provider edge (PE) routers, the export route target is sent along with the route as an extended community.

Step 8 **exit**

Example:

```
RP/0/RP0/CPU0:router(config-vrf-af)# exit
```

Exits VRF address family configuration mode and returns the router to VRF configuration mode.

Step 9 **exit**

Example:

```
RP/0/RP0/CPU0:router(config-vrf)# exit
```

Exits VRF configuration mode and returns the router to Global Configuration mode.

Step 10 **router bgp** *autonomous-system-number*

Example:

```
RP/0/RP0/CPU0:router(config)# router bgp 120
```

Enters BGP configuration mode allowing you to configure the BGP routing process.

Step 11 **vrf** *vrf-name*

Example:

```
RP/0/RP0/CPU0:router(config-bgp)# vrf vrf_1
```

Configures a VRF instance and enters VRF configuration mode for BGP routing.

Step 12 **rd** { *as-number* | *ip-address* | **auto** }

Example:

```
RP/0/RP0/CPU0:router(config-bgp-vrf)# rd auto
```

Automatically assigns a unique route distinguisher (RD) to vrf_1.

Step 13 Use the **commit** or **end** command.

commit - Saves the configuration changes and remains within the configuration session.

end - Prompts user to take one of these actions:

- **Yes** - Saves configuration changes and exits the configuration session.
- **No** - Exits the configuration session without committing the configuration changes.
- **Cancel** - Remains in the configuration mode, without committing the configuration changes.

Configuring VRF Interfaces on PE Routers for Each VPN Customer

Perform this task to associate a VPN routing and forwarding (VRF) instance with an interface or a subinterface on the PE routers.



Note You must remove IPv4/IPv6 addresses from an interface prior to assigning, removing, or changing an interface's VRF. If this is not done in advance, any attempt to change the VRF on an IP interface is rejected.

SUMMARY STEPS

1. **configure**
2. **interface** *type interface-path-id*
3. **vrf** *vrf-name*
4. **ipv4 address** *ipv4-address mask*
5. Use the **commit** or **end** command.

DETAILED STEPS

Step 1 **configure**

Example:

```
RP/0/RP0/CPU0:router# configure
```

Enters Global Configuration mode.

Step 2 **interface** *type interface-path-id*

Example:

```
RP/0/RP0/CPU0:router(config)# interface TenGigE 0/3/0/0
```

Enters interface configuration mode.

Step 3 `vrf vrf-name`

Example:

```
RP/0/RP0/CPU0:router(config-if)# vrf vrf_A
```

Configures a VRF instance and enters VRF configuration mode.

Step 4 `ipv4 address ipv4-address mask`

Example:

```
RP/0/RP0/CPU0:router(config-if)# ipv4 address 192.168.1.27 255.255.255.0
```

Configures a primary IPv4 address for the specified interface.

Step 5 Use the **commit** or **end** command.

commit - Saves the configuration changes and remains within the configuration session.

end - Prompts user to take one of these actions:

- **Yes** - Saves configuration changes and exits the configuration session.
- **No** - Exits the configuration session without committing the configuration changes.
- **Cancel** - Remains in the configuration mode, without committing the configuration changes.

Configuring BGP as the Routing Protocol Between the PE and CE Routers

Perform this task to configure PE-to-CE routing sessions using BGP.

SUMMARY STEPS

1. **configure**
2. **router bgp** *autonomous-system-number*
3. **bgp router-id** { *ip-address* }
4. **vrf** *vrf-name*
5. **label-allocation-mode per-ce**
6. **address-family ipv4 unicast**
7. Do one of the following:
 - **redistribute connected** [**metric** *metric-value*] [**route-policy** *route-policy-name*]
 - **redistribute isis** *process-id* [**level** { **1** | **1-inter-area** | **2** }] [**metric** *metric-value*] [**route-policy** *route-policy-name*]
 - **redistribute ospf** *process-id* [**match** { **external** [**1** | **2**] | **internal** | **nssa-external** [**1** | **2**] }] [**metric** *metric-value*] [**route-policy** *route-policy-name*]
 - **redistribute ospfv3** *process-id* [**match** { **external** [**1** | **2**] | **internal** | **nssa-external** [**1** | **2**] }] [**metric** *metric-value*] [**route-policy** *route-policy-name*]
 - **redistribute static** [**metric** *metric-value*] [**route-policy** *route-policy-name*]
8. **aggregate-address** *address/mask-length* [**as-set**] [**as-confed-set**] [**summary-only**] [**route-policy** *route-policy-name*]

9. **network** {*ip-address/prefix-length* | *ip-address mask* } [**route-policy** *route-policy-name*]
10. **exit**
11. **neighbor** *ip-address*
12. **remote-as** *autonomous-system-number*
13. **password** { **clear** | **encrypted** } *password*
14. **ebgp-multihop** [*tth-value*]
15. **address-family** **ipv4** **unicast**
16. **allowas-in** [*as-occurrence-number*]
17. **route-policy** *route-policy-name* **in**
18. **route-policy** *route-policy-name* **out**
19. Use the **commit** or **end** command.

DETAILED STEPS

Step 1 **configure**

Example:

```
RP/0/RP0/CPU0:router# configure
```

Enters Global Configuration mode.

Step 2 **router bgp** *autonomous-system-number*

Example:

```
RP/0/RP0/CPU0:router(config)# router bgp 120
```

Enters Border Gateway Protocol (BGP) configuration mode allowing you to configure the BGP routing process.

Step 3 **bgp router-id** {*ip-address*}

Example:

```
RP/0/RP0/CPU0:router(config-bgp)# bgp router-id 192.168.70.24
```

Configures the local router with a router ID of 192.168.70.24.

Step 4 **vrf** *vrf-name*

Example:

```
RP/0/RP0/CPU0:router(config-bgp)# vrf vrf_1
```

Configures a VPN routing and forwarding (VRF) instance and enters VRF configuration mode for BGP routing.

Step 5 **label-allocation-mode per-ce**

Example:

```
RP/0/RP0/CPU0:router(config-bgp-vrf)# label-allocation-mode per-ce
```

Sets the MPLS VPN label allocation mode for each customer edge (CE) label mode allowing the provider edge (PE) router to allocate one label for every immediate next-hop.

Step 6 **address-family ipv4 unicast**

Example:

```
RP/0/RP0/CPU0:router(config-bgp-vrf)# address-family ipv4 unicast
```

Enters VRF address family configuration mode for the IPv4 address family.

Step 7

Do one of the following:

- **redistribute connected** [**metric** *metric-value*] [**route-policy** *route-policy-name*]
- **redistribute isis** *process-id* [**level** { **1** | **1-inter-area** | **2** }] [**metric** *metric-value*] [**route-policy** *route-policy-name*]
- **redistribute ospf** *process-id* [**match** { **external** [**1** | **2**] | **internal** | **nssa-external** [**1** | **2**] }] [**metric** *metric-value*] [**route-policy** *route-policy-name*]
- **redistribute ospfv3** *process-id* [**match** { **external** [**1** | **2** | **internal** | **nssa-external** [**1** | **2**] }] [**metric** *metric-value*] [**route-policy** *route-policy-name*]
- **redistribute static** [**metric** *metric-value*] [**route-policy** *route-policy-name*]

Example:

```
RP/0/RP0/CPU0:router(config-bgp-vrf-af)# redistribute connected
```

Causes routes to be redistributed into BGP. The routes that can be redistributed into BGP are:

- Connected
- Intermediate System-to-Intermediate System (IS-IS)
- Open Shortest Path First (OSPF)
- Static

Step 8

aggregate-address *address/mask-length* [**as-set**] [**as-confed-set**] [**summary-only**] [**route-policy** *route-policy-name*]

Example:

```
RP/0/RP0/CPU0:router(config-bgp-vrf-af)# aggregate-address 10.0.0.0/8 as-set
```

Creates an aggregate address. The path advertised for this route is an autonomous system set consisting of all elements contained in all paths that are being summarized.

- The **as-set** keyword generates autonomous system set path information and community information from contributing paths.
- The **as-confed-set** keyword generates autonomous system confederation set path information from contributing paths.
- The **summary-only** keyword filters all more specific routes from updates.
- The **route-policy** *route-policy-name* keyword and argument specify the route policy used to set the attributes of the aggregate route.

Step 9 **network** {*ip-address/prefix-length* | *ip-address mask* } [**route-policy** *route-policy-name*]

Example:

```
RP/0/RP0/CPU0:router(config-bgp-vrf-af)# network 172.20.0.0/16
```

Configures the local router to originate and advertise the specified network.

Step 10 **exit**

Example:

```
RP/0/RP0/CPU0:router(config-bgp-vrf-af)# exit
```

Exits VRF address family configuration mode and returns the router to VRF configuration mode for BGP routing.

Step 11 **neighbor** *ip-address*

Example:

```
RP/0/RP0/CPU0:router(config-bgp-vrf)# neighbor 172.168.40.24
```

Places the router in VRF neighbor configuration mode for BGP routing and configures the neighbor IP address 172.168.40.24 as a BGP peer.

Step 12 **remote-as** *autonomous-system-number*

Example:

```
RP/0/RP0/CPU0:router(config-bgp-vrf-nbr)# remote-as 2002
```

Creates a neighbor and assigns it a remote autonomous system number.

Step 13 **password** { **clear** | **encrypted** } *password*

Example:

```
RP/0/RP0/CPU0:router(config-bgp-vrf-nbr)# password clear pswd123
```

Configures neighbor 172.168.40.24 to use MD5 authentication with the password pswd123.

Step 14 **ebgp-multihop** [*ttl-value*]

Example:

```
RP/0/RP0/CPU0:router(config-bgp-vrf-nbr)# ebgp-multihop
```

Allows a BGP connection to neighbor 172.168.40.24.

Step 15 **address-family** **ipv4** **unicast**

Example:

```
RP/0/RP0/CPU0:router(config-bgp-vrf-nbr)# address-family ipv4 unicast
```

Enters VRF neighbor address family configuration mode for BGP routing.

Step 16 **allowas-in** [*as-occurrence-number*]

Example:

```
RP/0/RP0/CPU0:router(config-bgp-vrf-nbr-af)# allowas-in 3
```

Replaces the neighbor autonomous system number (ASN) with the PE ASN in the AS path three times.

Step 17 **route-policy** *route-policy-name* **in**

Example:

```
RP/0/RP0/CPU0:router(config-bgp-vrf-nbr-af)# route-policy In-Ipv4 in
```

Applies the In-Ipv4 policy to inbound IPv4 unicast routes.

Step 18 **route-policy** *route-policy-name* **out**

Example:

```
RP/0/RP0/CPU0:router(config-bgp-vrf-nbr-af)# route-policy In-Ipv4 in
```

Applies the In-Ipv4 policy to outbound IPv4 unicast routes.

Step 19 Use the **commit** or **end** command.

commit - Saves the configuration changes and remains within the configuration session.

end - Prompts user to take one of these actions:

- **Yes** - Saves configuration changes and exits the configuration session.
- **No** - Exits the configuration session without committing the configuration changes.
- **Cancel** - Remains in the configuration mode, without committing the configuration changes.

Configuring RIPv2 as the Routing Protocol Between the PE and CE Routers

Perform this task to configure provider edge (PE)-to-customer edge (CE) routing sessions using Routing Information Protocol version 2 (RIPv2).

SUMMARY STEPS

1. **configure**
2. **router rip**
3. **vrf** *vrf-name*
4. **interface** *type instance*
5. **site-of-origin** { *as-number : number* | *ip-address : number* }
6. **exit**
7. Do one of the following:
 - **redistribute bgp** *as-number* [[**external** | **internal** | **local**] [**route-policy** *name*]

- **redistribute connected** [**route-policy** *name*]
- **redistribute isis** *process-id* [**level-1** | **level-1-2** | **level-2**] [**route-policy** *name*]
- **redistribute eigrp** *as-number* [**route-policy** *name*]
- **redistribute ospf** *process-id* [**match** { **external** [**1** | **2**] | **internal** | **nssa-external** [**1** | **2**] }] [**route-policy** *name*]
- **redistribute static** [**route-policy** *name*]

8. Use the **commit** or **end** command.

DETAILED STEPS

Step 1 **configure**

Example:

```
RP/0/RP0/CPU0:router# configure
```

Enters Global Configuration mode.

Step 2 **router rip**

Example:

```
RP/0/RP0/CPU0:router(config)# router rip
```

Enters the Routing Information Protocol (RIP) configuration mode allowing you to configure the RIP routing process.

Step 3 **vrf vrf-name**

Example:

```
RP/0/RP0/CPU0:router(config-rip)# vrf vrf_1
```

Configures a VPN routing and forwarding (VRF) instance and enters VRF configuration mode for RIP routing.

Step 4 **interface type instance**

Example:

```
RP/0/RP0/CPU0:router(config-rip-vrf)# interface TenGigE 0/3/0/0
```

Enters VRF interface configuration mode.

Step 5 **site-of-origin { as-number : number | ip-address : number }**

Example:

```
RP/0/RP0/CPU0:router(config-rip-vrf-if)# site-of-origin 200:1
```

Identifies routes that have originated from a site so that the re-advertisement of that prefix back to the source site can be prevented. Uniquely identifies the site from which a PE router has learned a route.

Step 6 **exit****Example:**

```
RP/0/RP0/CPU0:router(config-rip-vrf-if)# exit
```

Exits VRF interface configuration mode, and returns the router to VRF configuration mode for RIP routing.

Step 7 Do one of the following:

- **redistribute bgp** *as-number* [[**external** | **internal** | **local**]] [**route-policy** *name*]
- **redistribute connected** [**route-policy** *name*]
- **redistribute isis** *process-id* [**level-1** | **level-1-2** | **level-2**] [**route-policy** *name*]
- **redistribute eigrp** *as-number* [**route-policy** *name*]
- **redistribute ospf** *process-id* [**match** { **external** [**1** | **2**] | **internal** | **nssa-external** [**1** | **2**] }] [**route-policy** *name*]
- **redistribute static** [**route-policy** *name*]

Example:

```
RP/0/RP0/CPU0:router(config-rip-vrf)# redistribute connected
```

Causes routes to be redistributed into RIP. The routes that can be redistributed into RIP are:

- Border Gateway Protocol (BGP)
- Connected
- Enhanced Interior Gateway Routing Protocol (EIGRP)
- Intermediate System-to-Intermediate System (IS-IS)
- Open Shortest Path First (OSPF)
- Static

Step 8 Use the **commit** or **end** command.

commit - Saves the configuration changes and remains within the configuration session.

end - Prompts user to take one of these actions:

- **Yes** - Saves configuration changes and exits the configuration session.
- **No** - Exits the configuration session without committing the configuration changes.
- **Cancel** - Remains in the configuration mode, without committing the configuration changes.

Configuring Static Routes Between the PE and CE Routers

Perform this task to configure provider edge (PE)-to-customer edge (CE) routing sessions that use static routes.



Note You must remove IPv4/IPv6 addresses from an interface prior to assigning, removing, or changing an interface's VRF. If this is not done in advance, any attempt to change the VRF on an IP interface is rejected.

SUMMARY STEPS

1. **configure**
2. **router static**
3. **vrf vrf-name**
4. **address-family ipv4 unicast**
5. *prefix/mask [vrf vrf-name] { ip-address | type interface-path-id }*
6. *prefix/mask [vrf vrf-name] bfd fast-detect*
7. Use the **commit** or **end** command.

DETAILED STEPS**Step 1** **configure****Example:**

```
RP/0/RP0/CPU0:router# configure
```

Enters Global Configuration mode.

Step 2 **router static****Example:**

```
RP/0/RP0/CPU0:router(config)# router static
```

Enters static routing configuration mode allowing you to configure the static routing process.

Step 3 **vrf vrf-name****Example:**

```
RP/0/RP0/CPU0:router(config-static)# vrf vrf_1
```

Configures a VPN routing and forwarding (VRF) instance and enters VRF configuration mode for static routing.

Step 4 **address-family ipv4 unicast****Example:**

```
RP/0/RP0/CPU0:router(config-static-vrf)# address-family ipv4 unicast
```

Enters VRF address family configuration mode for the IPv4 address family.

Step 5 *prefix/mask [vrf vrf-name] { ip-address | type interface-path-id }***Example:**

```
RP/0/RP0/CPU0:router(config-static-vrf-afi)# 172.168.40.24/24 vrf vrf_1 10.1.1.1
```

Assigns the static route to vrf_1.

Step 6 *prefix/mask* [**vrf** *vrf-name*] **bfd fast-detect****Example:**

```
RP/0/RP0/CPU0:router(config-static-vrf-afi)# 172.168.40.24/24 vrf vrf_1 bfd fast-detect
```

Enables bidirectional forwarding detection (BFD) to detect failures in the path between adjacent forwarding engines. This option is available is when the forwarding router address is specified in Step 5 .

Step 7 Use the **commit** or **end** command.

commit - Saves the configuration changes and remains within the configuration session.

end - Prompts user to take one of these actions:

- **Yes** - Saves configuration changes and exits the configuration session.
- **No** - Exits the configuration session without committing the configuration changes.
- **Cancel** - Remains in the configuration mode, without committing the configuration changes.

Configuring OSPF as the Routing Protocol Between the PE and CE Routers

Perform this task to configure provider edge (PE)-to-customer edge (CE) routing sessions that use Open Shortest Path First (OSPF).

SUMMARY STEPS

1. **configure**
2. **router ospf** *process-name*
3. **vrf** *vrf-name*
4. **router-id** {*router-id* | type interface-path-id}
5. Do one of the following:
 - **redistribute bgp** *process-id* [**metric** *metric-value*] [**metric-type** {1 | 2}] [**route-policy** *policy-name*] [**tag** *tag-value*]
 - **redistribute connected** [**metric** *metric-value*] [**metric-type** {1 | 2}] [**route-policy** *policy-name*] [**tag** *tag-value*]
 - **redistribute ospf** *process-id* [**match** {external [1 | 2] | internal | nssa-external [1 | 2]}] [**metric** *metric-value*] [**metric-type** {1 | 2}] [**route-policy** *policy-name*] [**tag** *tag-value*]
 - **redistribute static** [**metric** *metric-value*] [**metric-type** {1 | 2}] [**route-policy** *policy-name*] [**tag** *tag-value*]
 - **redistribute eigrp** *process-id* [**match** {external [1 | 2] | internal | nssa-external [1 | 2]}] [**metric** *metric-value*] [**metric-type** {1 | 2}] [**route-policy** *policy-name*] [**tag** *tag-value*]
 - **redistribute rip** [**metric** *metric-value*] [**metric-type** {1 | 2}] [**route-policy** *policy-name*] [**tag** *tag-value*]
6. **area** *area-id*
7. **interface** type interface-path-id
8. Use the **commit** or **end** command.

DETAILED STEPS

Step 1 **configure**

Example:

```
RP/0/RP0/CPU0:router# configure
```

Enters Global Configuration mode.

Step 2 **router ospf process-name**

Example:

```
RP/0/RP0/CPU0:router(config)# router ospf 109
```

Enters OSPF configuration mode allowing you to configure the OSPF routing process.

Step 3 **vrf vrf-name**

Example:

```
RP/0/RP0/CPU0:router(config-ospf)# vrf vrf_1
```

Configures a VPN routing and forwarding (VRF) instance and enters VRF configuration mode for OSPF routing.

Step 4 **router-id {router-id | type interface-path-id}**

Example:

```
RP/0/RP0/CPU0:router(config-ospf-vrf)# router-id 172.20.10.10
```

Configures the router ID for the OSPF routing process.

Step 5 Do one of the following:

- **redistribute bgp** *process-id* [**metric** *metric-value*] [**metric-type** {1 | 2}] [**route-policy** *policy-name*] [**tag** *tag-value*]
- **redistribute connected** [**metric** *metric-value*] [**metric-type** {1 | 2}] [**route-policy** *policy-name*] [**tag** *tag-value*]
- **redistribute ospf** *process-id* [**match** {external [1 | 2] | internal | nssa-external [1 | 2]}] [**metric** *metric-value*] [**metric-type** {1 | 2}] [**route-policy** *policy-name*] [**tag** *tag-value*]
- **redistribute static** [**metric** *metric-value*] [**metric-type** {1 | 2}] [**route-policy** *policy-name*] [**tag** *tag-value*]
- **redistribute eigrp** *process-id* [**match** {external [1 | 2] | internal | nssa-external [1 | 2]}] [**metric** *metric-value*] [**metric-type** {1 | 2}] [**route-policy** *policy-name*] [**tag** *tag-value*]
- **redistribute rip** [**metric** *metric-value*] [**metric-type** {1 | 2}] [**route-policy** *policy-name*] [**tag** *tag-value*]

Example:

```
RP/0/RP0/CPU0:router(config-ospf-vrf)# redistribute connected
```

Causes routes to be redistributed into OSPF. The routes that can be redistributed into OSPF are:

- Border Gateway Protocol (BGP)
- Connected

- Enhanced Interior Gateway Routing Protocol (EIGRP)
- OSPF
- Static
- Routing Information Protocol (RIP)

Step 6 `area area-id`

Example:

```
RP/0/RP0/CPU0:router(config-ospf-vrf) # area 0
```

Configures the OSPF area as area 0.

Step 7 `interface type interface-path-id`

Example:

```
RP/0/RP0/CPU0:router(config-ospf-vrf-ar) # interface TenGigE 0/3/0/0
```

Associates interface TenGigE 0/3/0/0 with area 0.

Step 8 Use the **commit** or **end** command.

commit - Saves the configuration changes and remains within the configuration session.

end - Prompts user to take one of these actions:

- **Yes** - Saves configuration changes and exits the configuration session.
- **No** - Exits the configuration session without committing the configuration changes.
- **Cancel** - Remains in the configuration mode, without committing the configuration changes.

Configuring EIGRP as the Routing Protocol Between the PE and CE Routers

Perform this task to configure provider edge (PE)-to-customer edge (CE) routing sessions that use Enhanced Interior Gateway Routing Protocol (EIGRP).

Using EIGRP between the PE and CE routers allows you to transparently connect EIGRP customer networks through an MPLS-enabled Border Gateway Protocol (BGP) core network so that EIGRP routes are redistributed through the VPN across the BGP network as internal BGP (iBGP) routes.

Before you begin

BGP is configured in the network. See the *Implementing BGP* module in the *Routing Configuration Guide for Cisco CRS Routers*



Note You must remove IPv4/IPv6 addresses from an interface prior to assigning, removing, or changing an interface's VRF. If this is not done in advance, any attempt to change the VRF on an IP interface is rejected.

SUMMARY STEPS

1. **configure**
2. **router eigrp** *as-number*
3. **vrf** *vrf-name*
4. **address-family ipv4**
5. **router-id** *router-id*
6. **autonomous-system** *as-number*
7. **default-metric** *bandwidth delay reliability loading mtu*
8. **redistribute** { { **bgp** | **connected** | **isis** | **ospf** | **rip** | **static** } [*as-number* | *instance-name*] } [**route-policy** *name*]
9. **interface** *type interface-path-id*
10. **site-of-origin** { *as-number:number* | *ip-address : number* }
11. Use the **commit** or **end** command.

DETAILED STEPS**Step 1** **configure****Example:**

```
RP/0/RP0/CPU0:router# configure
```

Enters Global Configuration mode.

Step 2 **router eigrp** *as-number***Example:**

```
RP/0/RP0/CPU0:router(config)# router eigrp 24
```

Enters EIGRP configuration mode allowing you to configure the EIGRP routing process.

Step 3 **vrf** *vrf-name***Example:**

```
RP/0/RP0/CPU0:router(config-eigrp)# vrf vrf_1
```

Configures a VPN routing and forwarding (VRF) instance and enters VRF configuration mode for EIGRP routing.

Step 4 **address-family ipv4****Example:**

```
RP/0/RP0/CPU0:router(config-eigrp-vrf)# address family ipv4
```

Enters VRF address family configuration mode for the IPv4 address family.

Step 5 **router-id** *router-id***Example:**

```
RP/0/RP0/CPU0:router(config-eigrp-vrf-af)# router-id 172.20.0.0
```

Configures the router ID for the Enhanced Interior Gateway Routing Protocol (EIGRP) routing process.

Step 6 **autonomous-system** *as-number*

Example:

```
RP/0/RP0/CPU0:router(config-eigrp-vrf-af)# autonomous-system 6
```

Configures the EIGRP routing process to run within a VRF.

Step 7 **default-metric** *bandwidth delay reliability loading mtu*

Example:

```
RP/0/RP0/CPU0:router(config-eigrp-vrf-af)# default-metric 100000 4000 200 45 4470
```

Sets the metrics for an EIGRP.

Step 8 **redistribute** { { **bgp** | **connected** | **isis** | **ospf** | **rip** | **static** } [*as-number* | *instance-name*] } [**route-policy name**]

Example:

```
RP/0/RP0/CPU0:router(config-eigrp-vrf-af)# redistribute connected
```

Causes connected routes to be redistributed into EIGRP.

Step 9 **interface** *type interface-path-id*

Example:

```
RP/0/RP0/CPU0:router(config-eigrp-vrf-af)# interface TenGigE 0/3/0/0
```

Associates interface TenGigE 0/3/0/0 with the EIGRP routing process.

Step 10 **site-of-origin** { *as-number:number* | *ip-address : number* }

Example:

```
RP/0/RP0/CPU0:router(config-eigrp-vrf-af-if)# site-of-origin 201:1
```

Configures site of origin (SoO) on interface TenGigE 0/3/0/0.

Step 11 Use the **commit** or **end** command.

commit - Saves the configuration changes and remains within the configuration session.

end - Prompts user to take one of these actions:

- **Yes** - Saves configuration changes and exits the configuration session.
- **No** - Exits the configuration session without committing the configuration changes.

- **Cancel** - Remains in the configuration mode, without committing the configuration changes.

Configuring EIGRP Redistribution in the MPLS VPN

Perform this task for every provider edge (PE) router that provides VPN services to enable Enhanced Interior Gateway Routing Protocol (EIGRP) redistribution in the MPLS VPN.

Before you begin

The metric can be configured in the route-policy configuring using the **redistribute** command (or configured with the **default-metric** command). If an external route is received from another EIGRP autonomous system or a non-EIGRP network without a configured metric, the route is not installed in the EIGRP database. If an external route is received from another EIGRP autonomous system or a non-EIGRP network without a configured metric, the route is not advertised to the CE router. See the *Implementing EIGRP* module in the *Routing Configuration Guide for Cisco CRS Routers*.



Restriction Redistribution between native EIGRP VPN routing and forwarding (VRF) instances is not supported. This behavior is designed.

SUMMARY STEPS

1. **configure**
2. **router eigrp** *as-number*
3. **vrf** *vrf-name*
4. **address-family ipv4**
5. **redistribute bgp** [*as-number*] [**route-policy** *policy-name*]
6. Use the **commit** or **end** command.

DETAILED STEPS

Step 1 **configure**

Example:

```
RP/0/RP0/CPU0:router# configure
```

Enters Global Configuration mode.

Step 2 **router eigrp** *as-number*

Example:

```
RP/0/RP0/CPU0:router(config)# router eigrp 24
```

Enters EIGRP configuration mode allowing you to configure the EIGRP routing process.

Step 3 **vrf** *vrf-name*

Example:

```
RP/0/RP0/CPU0:router(config-eigrp)# vrf vrf_1
```

Configures a VRF instance and enters VRF configuration mode for EIGRP routing.

Step 4 address-family ipv4**Example:**

```
RP/0/RP0/CPU0:router(config-eigrp-vrf)# address family ipv4
```

Enters VRF address family configuration mode for the IPv4 address family.

Step 5 redistribute bgp [as-number] [route-policy policy-name]**Example:**

```
RP/0/RP0/CPU0:router(config-eigrp-vrf-af)# redistribute bgp 24 route-policy policy_A
```

Causes Border Gateway Protocol (BGP) routes to be redistributed into EIGRP.

Step 6 Use the **commit** or **end** command.

commit - Saves the configuration changes and remains within the configuration session.

end - Prompts user to take one of these actions:

- **Yes** - Saves configuration changes and exits the configuration session.
- **No** - Exits the configuration session without committing the configuration changes.
- **Cancel** - Remains in the configuration mode, without committing the configuration changes.

Providing VPN Connectivity Across Multiple Autonomous Systems with MPLS VPN Inter-AS with ASBRs Exchanging IPv4 Routes and MPLS Labels



Note This section is not applicable to Inter-AS over IP tunnels.

This section contains instructions for the following tasks:

Configuring ASBRs to Exchange IPv4 Routes and MPLS Labels

Perform this task to configure the autonomous system boundary routers (ASBRs) to exchange IPv4 routes and MPLS labels.

SUMMARY STEPS

1. **configure**
2. **router bgp** *autonomous-system-number*

3. **address-family ipv4 unicast**
4. **allocate-label all**
5. **neighbor ip-address**
6. **remote-as autonomous-system-number**
7. **address-family ipv4 labeled-unicast**
8. **route-policy route-policy-name in**
9. **route-policy route-policy-name out**
10. Use the **commit** or **end** command.

DETAILED STEPS

Step 1 **configure**

Example:

```
RP/0/RP0/CPU0:router# configure
```

Enters Global Configuration mode.

Step 2 **router bgp autonomous-system-number**

Example:

```
RP/0/RP0/CPU0:router(config)# router bgp 120
RP/0/RP0/CPU0:router(config-bgp)#
```

Enters Border Gateway Protocol (BGP) configuration mode allowing you to configure the BGP routing process.

Step 3 **address-family ipv4 unicast**

Example:

```
RP/0/RP0/CPU0:router(config-bgp)# address-family ipv4 unicast
RP/0/RP0/CPU0:router(config-bgp-af)#
```

Enters global address family configuration mode for the IPv4 unicast address family.

Step 4 **allocate-label all**

Example:

```
RP/0/CPU0:router(config-bgp-af)# allocate-label all
```

Allocates the MPLS labels for a specific IPv4 unicast or VPN routing and forwarding (VRF) IPv4 unicast routes so that the BGP router can send labels with BGP routes to a neighboring router that is configured for a labeled-unicast session.

Step 5 **neighbor ip-address**

Example:

```
RP/0/RP0/CPU0:router(config-bgp-af)# neighbor 172.168.40.24
```



```
RP/0/RP0/CPU0:router(config-bgp-nbr)#
```

Places the router in neighbor configuration mode for BGP routing and configures the neighbor IP address 172.168.40.24 as a BGP peer.

Step 6 **remote-as** *autonomous-system-number*

Example:

```
RP/0/RP0/CPU0:router(config-bgp-nbr)# remote-as 2002
```

Creates a neighbor and assigns it a remote autonomous system number.

Step 7 **address-family ipv4 labeled-unicast**

Example:

```
RP/0/RP0/CPU0:router(config-bgp-nbr)# address-family ipv4 labeled-unicast
RP/0/RP0/CPU0:router(config-bgp-nbr-af)
```

Enters neighbor address family configuration mode for the IPv4 labeled-unicast address family.

Step 8 **route-policy** *route-policy-name* **in**

Example:

```
RP/0/RP0/CPU0:router(config-bgp-nbr-af)# route-policy pass-all in
```

Applies a routing policy to updates that are received from a BGP neighbor.

- Use the *route-policy-name* argument to define the name of the of route policy. The example shows that the route policy name is defined as pass-all.
- Use the **in** keyword to define the policy for inbound routes.

Step 9 **route-policy** *route-policy-name* **out**

Example:

```
RP/0/RP0/CPU0:router(config-bgp-nbr-af)# route-policy pass-all out
```

Applies a routing policy to updates that are sent to a BGP neighbor.

- Use the *route-policy-name* argument to define the name of the of route policy. The example shows that the route policy name is defined as pass-all.
- Use the **out** keyword to define the policy for outbound routes.

Step 10 Use the **commit** or **end** command.

commit - Saves the configuration changes and remains within the configuration session.

end - Prompts user to take one of these actions:

- **Yes** - Saves configuration changes and exits the configuration session.
- **No** - Exits the configuration session without committing the configuration changes.

- **Cancel** - Remains in the configuration mode, without committing the configuration changes.

Configuring the Route Reflectors to Exchange VPN-IPv4 Routes

Perform this task to enable the route reflectors to exchange VPN-IPv4 routes by using multihop. This task specifies that the next-hop information and the VPN label are to be preserved across the autonomous system.

SUMMARY STEPS

1. **configure**
2. **router bgp** *autonomous-system-number*
3. **neighbor** *ip-address*
4. **remote-as** *autonomous-system-number*
5. **ebgp-multihop** [*ttl-value*]
6. **update-source** *type interface-path-id*
7. **address-family vpnv4 unicast**
8. **route-policy** *route-policy-name* **in**
9. **route-policy** *route-policy-name* **out**
10. **next-hop-unchanged**
11. Use the **commit** or **end** command.

DETAILED STEPS

Step 1 **configure**

Example:

```
RP/0/RP0/CPU0:router# configure
```

Enters Global Configuration mode.

Step 2 **router bgp** *autonomous-system-number*

Example:

```
RP/0/RP0/CPU0:router(config)# router bgp 120
RP/0/RP0/CPU0:router(config-bgp)#
```

Enters Border Gateway Protocol (BGP) configuration mode allowing you to configure the BGP routing process.

Step 3 **neighbor** *ip-address*

Example:

```
RP/0/RP0/CPU0:router(config-bgp)# neighbor 172.168.40.24
RP/0/RP0/CPU0:router(config-bgp-nbr)#
```

Places the router in neighbor configuration mode for BGP routing and configures the neighbor IP address 172.168.40.24 as a BGP peer.

Step 4 **remote-as** *autonomous-system-number***Example:**

```
RP/0/RP0/CPU0:router(config-bgp-nbr)# remote-as 2002
```

Creates a neighbor and assigns it a remote autonomous system number.

Step 5 **ebgp-multihop** [*ttl-value*]**Example:**

```
RP/0/RP0/CPU0:router(config-bgp-nbr)# ebgp-multihop
```

Enables multihop peerings with external BGP neighbors.

Step 6 **update-source** *type interface-path-id***Example:**

```
RP/0/RP0/CPU0:router(config-bgp-nbr)# update-source loopback0
```

Allows BGP sessions to use the primary IP address from a particular interface as the local address.

Step 7 **address-family vpnv4 unicast****Example:**

```
RP/0/RP0/CPU0:router(config-bgp-nbr)# address-family vpnv4 unicast
RP/0/RP0/CPU0:router(config-bgp-nbr-af)#
```

Configures VPNv4 address family.

Step 8 **route-policy** *route-policy-name* **in****Example:**

```
RP/0/RP0/CPU0:router(config-bgp-nbr-af)# route-policy pass-all in
```

Applies a routing policy to updates that are received from a BGP neighbor.

- Use the *route-policy-name* argument to define the name of the of route policy. The example shows that the route policy name is defined as pass-all.
- Use the **in** keyword to define the policy for inbound routes.

Step 9 **route-policy** *route-policy-name* **out****Example:**

```
RP/0/RP0/CPU0:router(config-bgp-nbr-af)# route-policy pass-all out
```

Applies a routing policy to updates that are sent to a BGP neighbor.

- Use the *route-policy-name* argument to define the name of the of route policy. The example shows that the route policy name is defined as pass-all.

- Use the **out** keyword to define the policy for outbound routes.

Step 10 **next-hop-unchanged****Example:**

```
RP/0/RP0/CPU0:router (config-bgp-nbr-af) # next-hop-unchanged
```

Disables overwriting of the next hop before advertising to external Border Gateway Protocol (eBGP) peers.

Step 11 Use the **commit** or **end** command.

commit - Saves the configuration changes and remains within the configuration session.

end - Prompts user to take one of these actions:

- **Yes** - Saves configuration changes and exits the configuration session.
- **No** - Exits the configuration session without committing the configuration changes.
- **Cancel** - Remains in the configuration mode, without committing the configuration changes.

Configuring the Route Reflector to Reflect Remote Routes in its AS

Perform this task to enable the route reflector (RR) to reflect the IPv4 routes and labels learned by the autonomous system boundary router (ASBR) to the provider edge (PE) routers in the autonomous system. This task is accomplished by making the ASBR and PE route reflector clients of the RR.

SUMMARY STEPS

1. **configure**
2. **router bgp** *autonomous-system-number*
3. **address-family ipv4 unicast**
4. **allocate-label all**
5. **neighbor** *ip-address*
6. **remote-as** *autonomous-system-number*
7. **update-source** *type interface-path-id*
8. **address-family ipv4 labeled-unicast**
9. **route-reflector-client**
10. **neighbor** *ip-address*
11. **remote-as** *autonomous-system-number*
12. **update-source** *type interface-path-id*
13. **address-family ipv4 labeled-unicast**
14. **route-reflector-client**
15. Use the **commit** or **end** command.

DETAILED STEPS**Step 1** **configure****Example:**

```
RP/0/RP0/CPU0:router# configure
```

Enters Global Configuration mode.

Step 2 **router bgp** *autonomous-system-number*

Example:

```
RP/0/RP0/CPU0:router(config)# router bgp 120
```

Enters Border Gateway Protocol (BGP) configuration mode allowing you to configure the BGP routing process.

Step 3 **address-family ipv4 unicast**

Example:

```
RP/0/RP0/CPU0:router(config-bgp)# address-family ipv4 unicast
RP/0/RP0/CPU0:router(config-bgp-af)#
```

Enters global address family configuration mode for the IPv4 unicast address family.

Step 4 **allocate-label all**

Example:

```
RP/0/RP0/CPU0:router(config-bgp-af)# allocate-label all
```

Allocates the MPLS labels for a specific IPv4 unicast or VPN routing and forwarding (VRF) IPv4 unicast routes so that the BGP router can send labels with BGP routes to a neighboring router that is configured for a labeled-unicast session.

Step 5 **neighbor** *ip-address*

Example:

```
RP/0/RP0/CPU0:router(config-bgp-af)# neighbor 172.168.40.24
RP/0/RP0/CPU0:router(config-bgp-nbr)#
```

Places the router in neighbor configuration mode for BGP routing and configures the neighbor IP address 172.168.40.24 as an ASBR eBGP peer.

Step 6 **remote-as** *autonomous-system-number*

Example:

```
RP/0/RP0/CPU0:router(config-bgp-nbr)# remote-as 2002
```

Creates a neighbor and assigns it a remote autonomous system number.

Step 7 **update-source** *type interface-path-id*

Example:

```
RP/0/RP0/CPU0:router(config-bgp-nbr)# update-source loopback0
```

Allows BGP sessions to use the primary IP address from a particular interface as the local address.

Step 8 **address-family ipv4 labeled-unicast**

Example:

```
RP/0/RP0/CPU0:router(config-bgp-nbr)# address-family ipv4 labeled-unicast
RP/0/RP0/CPU0:router(config-bgp-nbr-af)#
```

Enters neighbor address family configuration mode for the IPv4 labeled-unicast address family.

Step 9 **route-reflector-client**

Example:

```
RP/0/RP0/CPU0:router(config-bgp-nbr-af)# route-reflector-client
```

Configures the router as a BGP route reflector and neighbor 172.168.40.24 as its client.

Step 10 **neighbor ip-address**

Example:

```
RP/0/RP0/CPU0:router(config-bgp-nbr-af)# neighbor 10.40.25.2
RP/0/RP0/CPU0:router(config-bgp-nbr)#
```

Places the router in neighbor configuration mode for BGP routing and configures the neighbor IP address .40.25.2 as an VPNv4 iBGP peer.

Step 11 **remote-as autonomous-system-number**

Example:

```
RP/0/RP0/CPU0:router(config-bgp-nbr)# remote-as 2002
```

Creates a neighbor and assigns it a remote autonomous system number.

Step 12 **update-source type interface-path-id**

Example:

```
RP/0/RP0/CPU0:router(config-bgp-nbr)# update-source loopback0
```

Allows BGP sessions to use the primary IP address from a particular interface as the local address.

Step 13 **address-family ipv4 labeled-unicast**

Example:

```
RP/0/RP0/CPU0:router(config-bgp-nbr)# address-family ipv4 labeled-unicast
RP/0/RP0/CPU0:router(config-bgp-nbr-af)#
```

Enters neighbor address family configuration mode for the IPv4 labeled-unicast address family.

Step 14 **route-reflector-client**

Example:

```
RP/0/RP0/CPU0:router(config-bgp-nbr-af)# route-reflector-client
```

Configures the neighbor as a route reflector client.

Step 15 Use the **commit** or **end** command.

commit - Saves the configuration changes and remains within the configuration session.

end - Prompts user to take one of these actions:

- **Yes** - Saves configuration changes and exits the configuration session.
- **No** - Exits the configuration session without committing the configuration changes.
- **Cancel** - Remains in the configuration mode, without committing the configuration changes.

Providing VPN Connectivity Across Multiple Autonomous Systems with MPLS VPN Inter-AS with ASBRs Exchanging VPN-IPv4 Addresses

This section contains instructions for the following tasks:

Configuring the ASBRs to Exchange VPN-IPv4 Addresses for IP Tunnels

Perform this task to configure an external Border Gateway Protocol (eBGP) autonomous system boundary router (ASBR) to exchange VPN-IPv4 routes with another autonomous system.

SUMMARY STEPS

1. **configure**
2. **router bgp** *autonomous-system-number*
3. **address-family** { **ipv4 tunnel** }
4. **address-family** { **vpn4 unicast** }
5. **retain route-target** { **all** | **route-policy** *route-policy-name* }
6. **neighbor** *ip-address*
7. **remote-as** *autonomous-system-number*
8. **address-family** { **vpn4 unicast** }
9. **route-policy** *route-policy-name* { **in** }
10. **route-policy** *route-policy-name* { **out** }
11. **neighbor** *ip-address*
12. **remote-as** *autonomous-system-number*
13. **update-source** *type interface-path-id*
14. **address-family** { **ipv4 tunnel** }
15. **address-family** { **vpn4 unicast** }
16. Use the **commit** or **end** command.

DETAILED STEPS

Step 1 **configure**

Example:

```
RP/0/RP0/CPU0:router# configure
```

Enters the Global Configuration mode.

Step 2 **router bgp *autonomous-system-number***

Example:

```
RP/0/RP0/CPU0:router(config)# router bgp 120
RP/0/RP0/CPU0:router(config-bgp)#
```

Enters Border Gateway Protocol (BGP) configuration mode allowing you to configure the BGP routing process.

Step 3 **address-family { ipv4 tunnel }**

Example:

```
RP/0/RP0/CPU0:router(config-bgp)# address-family ipv4 tunnel
RP/0/RP0/CPU0:router(config-bgp-af)#
```

Configures IPv4 tunnel address family.

Step 4 **address-family { vpnv4 unicast }**

Example:

```
RP/0/RP0/CPU0:router(config-bgp-af)# address-family vpnv4 unicast
```

Configures VPNv4 address family.

Step 5 **retain route-target { all | route-policy *route-policy-name* }**

Example:

```
RP/0/RP0/CPU0:router(config-bgp-af)# retain route-target route-policy policy1
```

Retrieves VPNv4 table from PE routers.

The **retain route-target** command is required on an Inter-AS option B ASBR. You can use this command with either **all** or **route-policy** keyword

Step 6 **neighbor *ip-address***

Example:

```
RP/0/RP0/CPU0:router(config-bgp-af)# neighbor 172.168.40.24
RP/0/RP0/CPU0:router(config-bgp-nbr)#
```

Places the router in neighbor configuration mode for BGP routing and configures the neighbor IP address 172.168.40.24 as an ASBR eBGP peer.

Step 7 **remote-as *autonomous-system-number***

Example:

```
RP/0/RP0/CPU0:router(config-bgp-nbr)# remote-as 2002
```

Creates a neighbor and assigns it a remote autonomous system number.

Step 8 **address-family { vpnv4 unicast }**

Example:

```
RP/0/RP0/CPU0:router(config-bgp-nbr)# address-family vpnv4 unicast
RP/0/RP0/CPU0:router(config-bgp-nbr-af)#
```

Configures VPNv4 address family.

Step 9 **route-policy route-policy-name { in }**

Example:

```
RP/0/RP0/CPU0:router(config-bgp-nbr-af)# route-policy pass-all in
```

Applies a routing policy to updates that are received from a BGP neighbor.

- Use the *route-policy-name* argument to define the name of the of route policy. The example shows that the route policy name is defined as pass-all.
- Use the **in** keyword to define the policy for inbound routes.

Step 10 **route-policy route-policy-name { out }**

Example:

```
RP/0/RP0/CPU0:router(config-bgp-nbr-af)# route-policy pass-all out
```

Applies a routing policy to updates that are sent from a BGP neighbor.

- Use the *route-policy-name* argument to define the name of the route policy. The example shows that the route policy name is defined as pass-all.
- Use the **out** keyword to define the policy for outbound routes.

Step 11 **neighbor ip-address**

Example:

```
RP/0/RP0/CPU0:router(config-bgp-nbr-af)# neighbor 175.40.25.2
RP/0/RP0/CPU0:router(config-bgp-nbr)#
```

Places the router in neighbor configuration mode for BGP routing and configures the neighbor IP address 175.40.25.2 as an VPNv4 iBGP peer.

Step 12 **remote-as autonomous-system-number**

Example:

```
RP/0/RP0/CPU0:router(config-bgp-nbr)# remote-as 2002
```

Creates a neighbor and assigns it a remote autonomous system number.

Step 13 **update-source type interface-path-id**

Example:

```
RP/0/RP0/CPU0:router(config-bgp-nbr)# update-source loopback0
```

Allows BGP sessions to use the primary IP address from a particular interface as the local address.

Step 14 **address-family { ipv4 tunnel }**

Example:

```
RP/0/RP0/CPU0:router(config-bgp-nbr)# address-family ipv4 tunnel
RP/0/RP0/CPU0:router(config-bgp-nbr-af)#
```

Configures IPv4 tunnel address family.

Step 15 **address-family { vpnv4 unicast }**

Example:

```
RP/0/RP0/CPU0:router(config-bgp-nbr-af)# address-family vpnv4 unicast
```

Configures VPNv4 address family.

Step 16 Use the **commit** or **end** command.

commit - Saves the configuration changes and remains within the configuration session.

end - Prompts user to take one of these actions:

- **Yes** - Saves configuration changes and exits the configuration session.
- **No** - Exits the configuration session without committing the configuration changes.
- **Cancel** - Remains in the configuration mode, without committing the configuration changes.

Configuring a Static Route to an ASBR Peer

Perform this task to configure a static route to an ASBR peer.

SUMMARY STEPS

1. **configure**
2. **router static**
3. **address-family ipv4 unicast**
4. **A.B.C.D/length next-hop**
5. Use the **commit** or **end** command.

DETAILED STEPS

Step 1 **configure**

Example:

```
RP/0/RP0/CPU0:router# configure
```

Enters the Global Configuration mode.

Step 2 **router static**

Example:

```
RP/0/RP0/CPU0:router(config)# router static
RP/0/RP0/CPU0:router(config-static)#
```

Enters router static configuration mode.

Step 3 address-family ipv4 unicast

Example:

```
RP/0/RP0/CPU0:router(config-static)# address-family ipv4 unicast
RP/0/RP0/CPU0:router(config-static-afi)#
```

Enables an IPv4 address family.

Step 4 A.B.C.D/length next-hop

Example:

```
RP/0/RP0/CPU0:router(config-static-afi)# 10.10.10.10/32 10.9.9.9
```

Enters the address of the destination router (including IPv4 subnet mask).

Step 5 Use the **commit** or **end** command.

commit - Saves the configuration changes and remains within the configuration session.

end - Prompts user to take one of these actions:

- **Yes** - Saves configuration changes and exits the configuration session.
- **No** - Exits the configuration session without committing the configuration changes.
- **Cancel** - Remains in the configuration mode, without committing the configuration changes.

Configuring EBGP Routing to Exchange VPN Routes Between Subautonomous Systems in a Confederation

Perform this task to configure external Border Gateway Protocol (eBGP) routing to exchange VPN routes between subautonomous systems in a confederation.



Note To ensure that host routes for VPN-IPv4 eBGP neighbors are propagated (by means of the Interior Gateway Protocol [IGP]) to other routers and PE routers, specify the **redistribute connected** command in the IGP configuration portion of the confederation eBGP (CEBGP) router. If you are using Open Shortest Path First (OSPF), make sure that the OSPF process is not enabled on the CEBGP interface in which the “redistribute connected” subnet exists.

SUMMARY STEPS

1. **configure**
2. **router bgp** *autonomous-system-number*
3. **bgp confederation peers** *peer autonomous-system-number*

4. **bgp confederation identifier** *autonomous-system-number*
5. **address-family vpnv4 unicast**
6. **neighbor** *ip-address*
7. **remote-as** *autonomous-system-number*
8. **address-family vpnv4 unicast**
9. **route-policy** *route-policy-name* **in**
10. **route-policy** *route-policy-name* **out**
11. **next-hop-self**
12. Use the **commit** or **end** command.

DETAILED STEPS

Step 1 **configure**

Example:

```
RP/0/RP0/CPU0:router# configure
```

Enters Global Configuration mode.

Step 2 **router bgp** *autonomous-system-number*

Example:

```
RP/0/RP0/CPU0:router(config)# router bgp 120
RP/0/RP0/CPU0:router(config-bgp)#
```

Enters BGP configuration mode allowing you to configure the BGP routing process.

Step 3 **bgp confederation peers** *peer autonomous-system-number*

Example:

```
RP/0/RP0/CPU0:router(config-bgp)# bgp confederation peers 8
```

Configures the peer autonomous system number that belongs to the confederation.

Step 4 **bgp confederation identifier** *autonomous-system-number*

Example:

```
RP/0/RP0/CPU0:router(config-bgp)# bgp confederation identifier 5
```

Specifies the autonomous system number for the confederation ID.

Step 5 **address-family vpnv4 unicast**

Example:

```
RP/0/RP0/CPU0:router(config-bgp)# address-family vpnv4 unicast
RP/0/RP0/CPU0:router(config-bgp-af)#
```

Configures VPNv4 address family.

Step 6 **neighbor ip-address**

Example:

```
RP/0/RP0/CPU0:router(config-bgp-af)# neighbor 10.168.40.24
RP/0/RP0/CPU0:router(config-bgp-nbr)#
```

Places the router in neighbor configuration mode for BGP routing and configures the neighbor IP address 10.168.40.24 as a BGP peer.

Step 7 **remote-as autonomous-system-number**

Example:

```
RP/0/RP0/CPU0:router(config-bgp-nbr)# remote-as 2002
```

Creates a neighbor and assigns it a remote autonomous system number.

Step 8 **address-family vpnv4 unicast**

Example:

```
RP/0/RP0/CPU0:router(config-bgp-nbr)# address-family vpnv4 unicast
RP/0/RP0/CPU0:router(config-bgp-nbr-af)#
```

Configures VPNv4 address family.

Step 9 **route-policy route-policy-name in**

Example:

```
RP/0/RP0/CPU0:router(config-bgp-nbr-af)# route-policy In-Ipv4 in
```

Applies a routing policy to updates received from a BGP neighbor.

Step 10 **route-policy route-policy-name out**

Example:

```
RP/0/RP0/CPU0:router(config-bgp-nbr-af)# route-policy Out-Ipv4 out
```

Applies a routing policy to updates advertised to a BGP neighbor.

Step 11 **next-hop-self**

Example:

```
RP/0/RP0/CPU0:router(config-bgp-nbr-af)# next-hop-self
```

Disables next-hop calculation and let you insert your own address in the next-hop field of BGP updates.

Step 12 Use the **commit** or **end** command.

commit - Saves the configuration changes and remains within the configuration session.

end - Prompts user to take one of these actions:

- **Yes** - Saves configuration changes and exits the configuration session.
- **No** - Exits the configuration session without committing the configuration changes.
- **Cancel** - Remains in the configuration mode, without committing the configuration changes.

Configuring MPLS Forwarding for ASBR Confederations

Perform this task to configure MPLS forwarding for autonomous system boundary router (ASBR) confederations (in BGP) on a specified interface.



Note This configuration adds the implicit NULL rewrite corresponding to the peer associated with the interface, which is required to prevent BGP from automatically installing rewrites by LDP (in multihop instances).

SUMMARY STEPS

1. **configure**
2. **router bgp** *as-number*
3. **mpls activate**
4. **interface** *type interface-path-id*
5. Use the **commit** or **end** command.

DETAILED STEPS

Step 1 **configure**

Example:

```
RP/0/RP0/CPU0:router# configure
```

Enters Global Configuration mode.

Step 2 **router bgp** *as-number*

Example:

```
RP/0/RP0/CPU0:router(config)# router bgp 120
RP/0/RP0/CPU0:router(config-bgp)
```

Enters BGP configuration mode allowing you to configure the BGP routing process.

Step 3 **mpls activate**

Example:

```
RP/0/RP0/CPU0:router(config-bgp)# mpls activate
```

```
RP/0/RP0/CPU0:router(config-bgp-mpls)#
```

Enters BGP MPLS activate configuration mode.

Step 4 `interface` *type interface-path-id*

Example:

```
RP/0/RP0/CPU0:router(config-bgp-mpls)# interface GigabitEthernet 0/3/0/0
```

Enables MPLS on the interface.

Step 5 Use the **commit** or **end** command.

commit - Saves the configuration changes and remains within the configuration session.

end - Prompts user to take one of these actions:

- **Yes** - Saves configuration changes and exits the configuration session.
- **No** - Exits the configuration session without committing the configuration changes.
- **Cancel** - Remains in the configuration mode, without committing the configuration changes.

Configuring a Static Route to an ASBR Confederation Peer

Perform this task to configure a static route to an Inter-AS confederation peer. For more detailed information, see [“Configuring a Static Route to a Peer”](#) section.

SUMMARY STEPS

1. **configure**
2. **router static**
3. **address-family ipv4 unicast**
4. **A.B.C.D/length** *next-hop*
5. Use the **commit** or **end** command.

DETAILED STEPS

Step 1 `configure`

Example:

```
RP/0/RP0/CPU0:router# configure
```

Enters Global Configuration mode.

Step 2 `router static`

Example:

```
RP/0/RP0/CPU0:router(config)# router static
```

```
RP/0/RP0/CPU0:router(config-static)#
```

Enters router static configuration mode.

Step 3 address-family ipv4 unicast

Example:

```
RP/0/RP0/CPU0:router(config-static)# address-family ipv4 unicast
RP/0/RP0/CPU0:router(config-static-afi)#
```

Enables an IPv4 address family.

Step 4 A.B.C.D/length next-hop

Example:

```
RP/0/RP0/CPU0:router(config-static-afi)# 10.10.10.10/32 10.9.9.9
```

Enters the address of the destination router (including IPv4 subnet mask).

Step 5 Use the **commit** or **end** command.

commit - Saves the configuration changes and remains within the configuration session.

end - Prompts user to take one of these actions:

- **Yes** - Saves configuration changes and exits the configuration session.
- **No** - Exits the configuration session without committing the configuration changes.
- **Cancel** - Remains in the configuration mode, without committing the configuration changes.

Configuring Carrier Supporting Carrier

Perform the tasks in this section to configure Carrier Supporting Carrier (CSC):

Identifying the Carrier Supporting Carrier Topology

Before you configure the MPLS VPN CSC with BGP, you must identify both the backbone and customer carrier topology.



Note You can connect multiple CSC-CE routers to the same PE, or you can connect a single CSC-CE router to multiple CSC-PEs using more than one CSC-CE interface to provide redundancy and multiple path support in a CSC topology.

Perform this task to identify the carrier supporting carrier topology.

SUMMARY STEPS

1. Identify the type of customer carrier, ISP, or MPLS VPN service provider.
2. Identify the CE routers.

3. Identify the customer carrier core router configuration.
4. Identify the customer carrier edge (CSC-CE) routers.
5. Identify the backbone carrier router configuration.

DETAILED STEPS

- Step 1** Identify the type of customer carrier, ISP, or MPLS VPN service provider.
Sets up requirements for configuration of carrier supporting carrier network.
- Step 2** Identify the CE routers.
Sets up requirements for configuration of CE to PE connections.
- Step 3** Identify the customer carrier core router configuration.
Sets up requirements for configuration between core (P) routers and between P routers and edge routers (PE and CSC-CE routers).
- Step 4** Identify the customer carrier edge (CSC-CE) routers.
Sets up requirements for configuration of CSC-CE to CSC-PE connections.
- Step 5** Identify the backbone carrier router configuration.
Sets up requirements for configuration between CSC core routers and between CSC core routers and edge routers (CSC-CE and CSC-PE routers).
-

Configuring the Backbone Carrier Core

Configuring the backbone carrier core requires setting up connectivity and routing functions for the CSC core and the CSC-PE routers. To do so, you must complete the following high-level tasks:

- Verify IP connectivity in the CSC core.
- Verify LDP configuration in the CSC core.



Note This task is not applicable to CSC over IP tunnels.

- Configure VRFs for CSC-PE routers.
- Configure multiprotocol BGP for VPN connectivity in the backbone carrier.

Configuring the CSC-PE and CSC-CE Routers

Perform the following tasks to configure links between a CSC-PE router and the carrier CSC-CE router for an MPLS VPN CSC network that uses BGP to distribute routes and MPLS labels:

The following figure shows the configuration for the peering with directly connected interfaces between CSC-PE and CSC-CE routers. This configuration is used as the example in the tasks that follow.

Figure 39: Configuration for Peering with Directly Connected Interfaces Between CSC-PE and CSC-CE Routers



Configuring a CSC-PE

Perform this task to configure a CSC-PE.

SUMMARY STEPS

1. **configure**
2. **router bgp** *as-number*
3. **address-family vpnv4 unicast**
4. **neighbor** *A.B.C.D*
5. **remote-as** *as-number*
6. **update-source** *type interface-path-id*
7. **address-family vpv4 unicast**
8. **vrf** *vrf-name*
9. **rd** {*as-number:nn* | *ip-address:nn* | **auto**}
10. **address-family ipv4 unicast**
11. **allocate-label** **all**
12. **neighbor** *A.B.C.D*
13. **remote-as** *as-number*
14. **address-family ipv4 labeled-unicast**
15. **route-policy** *route-policy-name* **in**
16. **route-policy** *route-policy-name* **out**
17. Use the **commit** or **end** command.

DETAILED STEPS

Step 1 **configure**

Example:

```
RP/0/RP0/CPU0:router# configure
```

Enters Global Configuration mode.

Step 2 **router bgp** *as-number*

Example:

```
RP/0/RP0/CPU0:router(config)# router bgp 2
```

Configures a BGP routing process and enters router configuration mode.

- Range for 2-byte numbers is 1 to 65535. Range for 4-byte numbers is 1.0 to 65535.65535.

Step 3 **address-family vpnv4 unicast****Example:**

```
RP/0/RP0/CPU0:router(config-bgp)# address-family vpnv4 unicast
RP/0/RP0/CPU0:router(config-bgp-af)#
```

Configures VPNv4 address family.

Step 4 **neighbor A.B.C.D****Example:**

```
RP/0/RP0/CPU0:router(config-bgp-af)#neighbor 10.10.10.0
RP/0/RP0/CPU0:router(config-bgp-nbr)#
```

Configures the IP address for the BGP neighbor.

Step 5 **remote-as as-number****Example:**

```
RP/0/RP0/CPU0:router(config-bgp-nbr)# remote-as 888
```

Configures the AS number for the BGP neighbor.

Step 6 **update-source type interface-path-id****Example:**

```
RP/0/RP0/CPU0:router(config-bgp-nbr)# update-source loopback0
```

Allows BGP sessions to use the primary IP address from a particular interface as the local address.

Step 7 **address-family vpnv4 unicast****Example:**

```
RP/0/RP0/CPU0:router(config-bgp-nbr)# address-family vpnv4 unicast
RP/0/RP0/CPU0:router(config-bgp-nbr-af)#
```

Configures VPNv4 unicast address family.

Step 8 **vrf vrf-name****Example:**

```
RP/0/RP0/CPU0:router(config-bgp-nbr-af)# vrf 9999
RP/0/RP0/CPU0:router(config-bgp-vrf)#
```

Configures a VRF instance.

Step 9 **rd {as-number:nn | ip-address:nn | auto}****Example:**

```
RP/0/RP0/CPU0:router(config-bgp-vrf)# rd auto
RP/0/RP0/CPU0:router(config-bgp-vrf)# address-family ipv4 unicast
```

Configures a route distinguisher.

Note Use the **auto** keyword to automatically assign a unique route distinguisher.

Step 10 **address-family ipv4 unicast**

Example:

```
RP/0/RP0/CPU0:router(config-bgp-vrf-af)# address-family ipv4 unicast
RP/0/0/CPU0:router(config-bgp-vrf-af)#
```

Example:

Configures IPv4 unicast address family.

Step 11 **allocate-label all**

Example:

```
RP/0/RP0/CPU0:router(config-bgp-vrf-af)# allocate-label all
```

Allocate labels for all local prefixes and prefixes received with labels.

Step 12 **neighbor A.B.C.D**

Example:

```
RP/0/RP0/CPU0:router(config-bgp-vrf-af)# neighbor 10.10.10.0
RP/0/RP0/CPU0:router(config-bgp-vrf-nbr)#
```

Configures the IP address for the BGP neighbor.

Step 13 **remote-as as-number**

Example:

```
RP/0/RP0/CPU0:router(config-bgp-vrf-nbr)#remote-as 888
```

Enables the exchange of information with a neighboring BGP router.

Step 14 **address-family ipv4 labeled-unicast**

Example:

```
RP/0/RP0/CPU0:router(config-bgp-vrf-nbr)# address-family ipv4 labeled-unicast
RP/0/RP0/CPU0:router(config-bgp-vrf-nbr-af)#
```

Configures IPv4 labeled-unicast address family.

Step 15 **route-policy route-policy-name in**

Example:

```
RP/0/RP0/CPU0:router(config-bgp-vrf-nbr-af)# route-policy pass-all in
```

Applies the pass-all policy to all inbound routes.

Step 16 `route-policy route-policy-name out`

Example:

```
RP/0/RP0/CPU0:router(config-bgp-vrf-nbr-af)# route-policy pass-all out
```

Applies the pass-all policy to all outbound routes.

Step 17 Use the **commit** or **end** command.

commit - Saves the configuration changes and remains within the configuration session.

end - Prompts user to take one of these actions:

- **Yes** - Saves configuration changes and exits the configuration session.
- **No** - Exits the configuration session without committing the configuration changes.
- **Cancel** - Remains in the configuration mode, without committing the configuration changes.

Configuring PE to CE Core

This task describes how to configure a PE to Customer Edge (CE) core.

SUMMARY STEPS

1. **configure**
2. **router bgp** *as-number*
3. **vrf** *vrf-name*
4. **bgp router-id** *ip-address*
5. **label-allocation-mode** { *per-ce* | *per-vrf* }
6. **address-family ipv6 unicast**
7. **redistribute** {*connected* | *static* | *eigrp* }
8. **neighbor** *ip-address*
9. **remote-as** *as-number*
10. **ebgp-multihop** { *maximum hops* | *mpls* }
11. **address-family ipv6 unicast**
12. **site-of-origin** [*as-number:nn* | *ip-address:nn*]
13. **as-override**
14. **allowas-in** [*as-occurrence-number*]
15. Use the **commit** or **end** command.

DETAILED STEPS

Step 1 **configure**

Example:

```
RP/0/RP0/CPU0:router# configure
```

Enters the Global Configuration mode.

Step 2 **router bgp** *as-number*

Example:

```
RP/0/RP0/CPU0:router(config)# router bgp 10
```

Specifies the BGP AS number and enters the BGP configuration mode, allowing you to configure the BGP routing process.

Step 3 **vrf** *vrf-name*

Example:

```
RP/0/RP0/CPU0:router(config-bgp)# vrf vrf-pe
```

Configures a VRF instance.

Step 4 **bgp router-id** *ip-address*

Example:

```
RP/0/RP0/CPU0:router(config-bgp-vrf)#bgp router-id 172.16.9.9
```

Configures a fixed router ID for a BGP-speaking router.

Step 5 **label-allocation-mode** { **per-ce** | **per-vrf** }

Example:

```
RP/0/RP0/CPU0:router(config-bgp-vrf)# label-allocation-mode per-ce
```

Configures the per-CE label allocation mode to avoid an extra lookup on the PE router and conserve label space (per-prefix is the default label allocation mode). In this mode, the PE router allocates one label for every immediate next-hop (in most cases, this would be a CE router). This label is directly mapped to the next hop, so there is no VRF route lookup performed during data forwarding. However, the number of labels allocated would be one for each CE rather than one for each VRF. Because BGP knows all the next hops, it assigns a label for each next hop (not for each PE-CE interface). When the outgoing interface is a multiaccess interface and the media access control (MAC) address of the neighbor is not known, Address Resolution Protocol (ARP) is triggered during packet forwarding.

The per-vrf keyword configures the same label to be used for all the routes advertised from a unique VRF.

Step 6 **address-family ipv6 unicast**

Example:

```
RP/0/RP0/CPU0:router(config-bgp-vrf)# address-family ipv6 unicast
```

Specifies an IPv6 address family unicast and enters address family configuration submenu.

To see a list of all the possible keywords and arguments for this command, use the CLI help (?).

Step 7 **redistribute** { **connected** | **static** | **eigrp** }

Example:

```
RP/0/RP0/CPU0:router(config-bgp-vrf-af)#
```

Causes routes from the specified instance to be redistributed into BGP.

Step 8 **neighbor** *ip-address*

Example:

```
RP/0/RP0/CPU0:router(config-bgp-vrf)# neighbor 10.0.0.0
```

Configures a CE neighbor. The ip-address argument must be a private address.

Step 9 **remote-as** *as-number*

Example:

```
RP/0/RP0/CPU0:router(config-bgp-vrf-nbr)# remote-as 2
```

Configures the remote AS for the CE neighbor.

Step 10 **ebgp-multihop** { *maximum hops* | **mpls** }

Example:

```
RP/0/RP0/CPU0:router(config-bgp-vrf-nbr)# ebgp-multihop 55
```

Configures the CE neighbor to accept and attempt BGP connections to external peers residing on networks that are not directly connected.

Step 11 **address-family ipv6 unicast**

Example:

```
RP/0/RP0/CPU0:router(config-bgp-vrf-nbr)# address-family ipv6 unicast
```

Specifies an IPv6 address family unicast and enters address family configuration submode.

To see a list of all the possible keywords and arguments for this command, use the CLI help (?).

Step 12 **site-of-origin** [*as-number:nn* | *ip-address:nn*]

Example:

```
RP/0/RP0/CPU0:router(config-bgp-vrf-nbr-af)# site-of-origin 234:111
```

Configures the site-of-origin (SoO) extended community. Routes that are learned from this CE neighbor are tagged with the SoO extended community before being advertised to the rest of the PEs. SoO is frequently used to detect loops when as-override is configured on the PE router. If the prefix is looped back to the same site, the PE detects this and does not send the update to the CE.

Step 13 **as-override**

Example:

```
RP/0/RP0/CPU0:router(config-bgp-vrf-nbr-af)# as-override
```

Configures AS override on the PE router. This causes the PE router to replace the CE's ASN with its own (PE) ASN.

Note This loss of information could lead to routing loops; to avoid loops caused by as-override, use it in conjunction with site-of-origin.

Step 14 **allowas-in** [*as-occurrence-number*]

Example:

```
RP/0/RP0/CPU0:router(config-bgp-vrf-nbr-af)# allowas-in 5
```

Allows an AS path with the PE autonomous system number (ASN) a specified number of times.

Hub and spoke VPN networks need the looping back of routing information to the HUB PE through the HUB CE. When this happens, due to the presence of the PE ASN, the looped-back information is dropped by the HUB PE. To avoid this, use the allowas-in command to allow prefixes even if they have the PEs ASN up to the specified number of times.

Step 15 Use the **commit** or **end** command.

commit - Saves the configuration changes and remains within the configuration session.

end - Prompts user to take one of these actions:

- **Yes** - Saves configuration changes and exits the configuration session.
- **No** - Exits the configuration session without committing the configuration changes.
- **Cancel** - Remains in the configuration mode, without committing the configuration changes.

Configuring a Static Route to a Peer

Perform this task to configure a static route to an Inter-AS or CSC-CE peer.

When you configure an Inter-AS or CSC peer, BGP allocates a label for a /32 route to that peer and performs a NULL label rewrite. When forwarding a labeled packet to the peer, the router removes the top label from the label stack; however, in such an instance, BGP expects a /32 route to the peer. This task ensures that there is, in fact, a /32 route to the peer.

Please be aware of the following facts before performing this task:

- A /32 route is not required to establish BGP peering. A route using a shorter prefix length will also work.
- A shorter prefix length route is not associated with the allocated label; even though the BGP session comes up between the peers, without the static route, forwarding will not work.



Note To configure a static route on a CSC-PE, you must configure the router under the VRF (as noted in the detailed steps).

SUMMARY STEPS

1. **configure**

2. **router static**
3. **address-family ipv4 unicast**
4. **A.B.C.D/length next-hop**
5. Use the **commit** or **end** command.

DETAILED STEPS

Step 1 **configure**

Example:

```
RP/0/RP0/CPU0:router# configure
```

Enters the Global Configuration mode.

Step 2 **router static**

Example:

```
RP/0/RP0/CPU0:router(config)# router static
```

Enters router static configuration mode.

Step 3 **address-family ipv4 unicast**

Example:

```
RP/0/RP0/CPU0:router(config-static)# address-family ipv4 unicast
```

Enables an IPv4 address family.

Note To configure a static route on a CSC-PE, you must first configure the VRF using the **vrf** command before **address-family**.

Step 4 **A.B.C.D/length next-hop**

Example:

```
RP/0/RP0/CPU0:router(config-static-afi)# 10.10.10.10/32 10.9.9.9
```

Enters the address of the destination router (including IPv4 subnet mask).

Step 5 Use the **commit** or **end** command.

commit - Saves the configuration changes and remains within the configuration session.

end - Prompts user to take one of these actions:

- **Yes** - Saves configuration changes and exits the configuration session.
 - **No** - Exits the configuration session without committing the configuration changes.
 - **Cancel** - Remains in the configuration mode, without committing the configuration changes.
-

Verifying the MPLS Layer 3 VPN Configuration

Perform this task to verify the MPLS Layer 3 VPN configuration.

SUMMARY STEPS

1. **show running-config router bgp** *as-number* **vrf** *vrf-name*
2. **show running-config routes**
3. **show ospf vrf** *vrf-name* **database**
4. **show running-config router bgp** *as-number* **vrf** *vrf-name* **neighbor** *ip-address*
5. **show bgp vrf** *vrf-name* **summary**
6. **show bgp vrf** *vrf-name* **neighbors** *ip-address*
7. **show bgp vrf** *vrf-name*
8. **show route vrf** *vrf-name* *ip-address*
9. **show bgp vpn unicast summary**
10. **show running-config router isis**
11. **show running-config mpls**
12. **show isis adjacency**
13. **show mpls ldp forwarding**
14. **show bgp vpnv4 unicast** or **show bgp vrf** *vrf-name*
15. **show bgp vrf** *vrf-name* **imported-routes**
16. **show route vrf** *vrf-name* *ip-address*
17. **show cef vrf** *vrf-name* *ip-address*
18. **show cef vrf** *vrf-name* *ip-address* **location** *node-id*
19. **show bgp vrf** *vrf-name* *ip-address*
20. **show ospf vrf** *vrf-name* **database**

DETAILED STEPS

Step 1 **show running-config router bgp** *as-number* **vrf** *vrf-name*

Example:

```
RP/0/RP0/CPU0:router# show running-config router bgp 3 vrf vrf_A
```

Displays the specified VPN routing and forwarding (VRF) content of the currently running configuration.

Step 2 **show running-config routes**

Example:

```
RP/0/RP0/CPU0:router# show running-config routes
```

Displays the Open Shortest Path First (OSPF) routes table in the currently running configuration.

Step 3 **show ospf vrf** *vrf-name* **database**

Example:

```
RP/0/RP0/CPU0:router# show ospf vrf vrf_A database
```

Displays lists of information related to the OSPF database for a specified VRF.

Step 4 **show running-config router bgp *as-number* vrf *vrf-name* neighbor *ip-address***

Example:

```
RP/0/RP0/CPU0:router# show running-config router bgp 3 vrf vrf_A neighbor 172.168.40.24
```

Displays the Border Gateway Protocol (BGP) VRF neighbor content of the currently running configuration.

Step 5 **show bgp vrf *vrf-name* summary**

Example:

```
RP/0/RP0/CPU0:router# show bgp vrf vrf_A summary
```

Displays the status of the specified BGP VRF connections.

Step 6 **show bgp vrf *vrf-name* neighbors *ip-address***

Example:

```
RP/0/RP0/CPU0:router# show bgp vrf vrf_A neighbors 172.168.40.24
```

Displays information about BGP VRF connections to the specified neighbors.

Step 7 **show bgp vrf *vrf-name***

Example:

```
RP/0/RP0/CPU0:router# show bgp vrf vrf_A
```

Displays information about a specified BGP VRF.

Step 8 **show route vrf *vrf-name* *ip-address***

Example:

```
RP/0/RP0/CPU0:router# show route vrf vrf_A 10.0.0.0
```

Displays the current routes in the Routing Information Base (RIB) for a specified VRF.

Step 9 **show bgp vpn unicast summary**

Example:

```
RP/0/RP0/CPU0:router# show bgp vpn unicast summary
```

Displays the status of all BGP VPN unicast connections.

Step 10 **show running-config router isis**

Example:

```
RP/0/RP0/CPU0:router# show running-config router isis
```

Displays the Intermediate System-to-Intermediate System (IS-IS) content of the currently running configuration.

Step 11 **show running-config mpls****Example:**

```
RP/0/RP0/CPU0:router# show running-config mpls
```

Displays the MPLS content of the currently running-configuration.

Step 12 **show isis adjacency****Example:**

```
RP/0/RP0/CPU0:router# show isis adjacency
```

Displays IS-IS adjacency information.

Step 13 **show mpls ldp forwarding****Example:**

```
RP/0/RP0/CPU0:router# show mpls ldp forwarding
```

Displays the Label Distribution Protocol (LDP) forwarding state installed in MPLS forwarding.

Step 14 **show bgp vpnv4 unicast** or **show bgp vrf vrf-name****Example:**

```
RP/0/RP0/CPU0:router# show bgp vpnv4 unicast
```

Displays entries in the BGP routing table for VPNv4 or VPNv6 unicast addresses.

Step 15 **show bgp vrf vrf-name imported-routes****Example:**

```
RP/0/RP0/CPU0:router# show bgp vrf vrf_A imported-routes
```

Displays BGP information for routes imported into specified VRF instances.

Step 16 **show route vrf vrf-name ip-address****Example:**

```
RP/0/RP0/CPU0:router# show route vrf vrf_A 10.0.0.0
```

Displays the current specified VRF routes in the RIB.

Step 17 **show cef vrf** *vrf-name ip-address*

Example:

```
RP/0/RP0/CPU0:router# show cef vrf vrf_A 10.0.0.1
```

Displays the IPv4 Cisco Express Forwarding (CEF) table for a specified VRF.

Step 18 **show cef vrf** *vrf-name ip-address location node-id*

Example:

```
RP/0/RP0/CPU0:router# show cef vrf vrf_A 10.0.0.1 location 0/1/cpu0
```

Displays the IPv4 CEF table for a specified VRF and location.

Step 19 **show bgp vrf** *vrf-name ip-address*

Example:

```
RP/0/RP0/CPU0:router# show bgp vrf vrf_A 10.0.0.0
```

Displays entries in the BGP routing table for VRF vrf_A.

Step 20 **show ospf vrf** *vrf-name database*

Example:

```
RP/0/RP0/CPU0:router# show ospf vrf vrf_A database
```

Displays lists of information related to the OSPF database for a specified VRF.

Configuring L3VPN over GRE

Perform the following tasks to configure L3VPN over GRE:

Creating a GRE Tunnel between Provider Edge Routers

Perform this task to configure a GRE tunnel between provider edge routers.

SUMMARY STEPS

1. **configure**
2. **interface tunnel-ip** *number*
3. **ipv4 address** *ipv4-address subnet-mask*
4. **ipv6 address** *ipv6-prefix/prefix-length*
5. **tunnel mode gre ipv4**
6. **tunnel source** *type path-id*
7. **tunnel destination** *ip-address*
8. Use the **commit** or **end** command.

DETAILED STEPS

Step 1 **configure**

Example:

```
RP/0/RP0/CPU0:router# configure
```

Enters the Global Configuration mode.

Step 2 **interface tunnel-ip *number***

Example:

```
RP/0/RP0/CPU0:router(config)# interface tunnel-ip 4000
```

Enters tunnel interface configuration mode.

- *number* is the number associated with the tunnel interface.

Step 3 **ipv4 address *ipv4-address subnet-mask***

Example:

```
RP/0/RP0/CPU0:router(config-if)# ipv4 address 10.0.0.1 255.0.0.0
```

Specifies the IPv4 address and subnet mask for the interface.

- *ipv4-address* specifies the IP address of the interface.
- *subnet-mask* specifies the subnet mask of the interface.

Step 4 **ipv6 address *ipv6-prefix/prefix-length***

Example:

```
RP/0/RP0/CPU0:router(config-if)# ipv6 address 100:1:1:1::1/64
```

Specifies an IPv6 network assigned to the interface.

Step 5 **tunnel mode gre ipv4**

Example:

```
RP/0/RP0/CPU0:router(config-if)# tunnel mode gre ipv4
```

Sets the encapsulation mode of the tunnel interface to GRE.

Step 6 **tunnel source *type path-id***

Example:

```
RP/0/RP0/CPU0:router(config-if)# tunnel source TenGigE0/2/0/1
```

Specifies the source of the tunnel interface.

Step 7 `tunnel destination ip-address`

Example:

```
RP/0/RP0/CPU0:router(config-if)# tunnel destination 145.12.5.2
```

Defines the tunnel destination.

Step 8 Use the **commit** or **end** command.

commit - Saves the configuration changes and remains within the configuration session.

end - Prompts user to take one of these actions:

- **Yes** - Saves configuration changes and exits the configuration session.
- **No** - Exits the configuration session without committing the configuration changes.
- **Cancel** - Remains in the configuration mode, without committing the configuration changes.

Configuring IGP between Provider Edge Routers

Perform this task to configure IGP between provider edge routers.

SUMMARY STEPS

1. **configure**
2. **router ospf** *process-name*
3. **nsr**
4. **router-id** { *router-id* }
5. **mpls ldp sync**
6. **dead-interval** *seconds*
7. **hello-interval** *seconds*
8. **area** *area-id*
9. **interface tunnel-ip** *number*
10. Use the **commit** or **end** command.

DETAILED STEPS

Step 1 **configure**

Example:

```
RP/0/RP0/CPU0:router# configure
```

Enters the Global Configuration mode.

Step 2 **router ospf** *process-name*

Example:

```
RP/0/RP0/CPU0:router(config)# router ospf 1
```

Enables OSPF routing for the specified routing process and places the router in router configuration mode.

Step 3 **nsr**

Example:

```
RP/0/RP0/CPU0:router(config-ospf)# nsr
```

Activates BGP NSR.

Step 4 **router-id** { *router-id* }

Example:

```
RP/0/RP0/CPU0:router(config-ospf)# router-id 10.0.0.1
```

Configures a router ID for the OSPF process.

Note We recommend using a stable IP address as the router ID.

Step 5 **mpls ldp sync**

Example:

```
RP/0/RP0/CPU0:router(config-ospf)# mpls ldp sync
```

Enables MPLS LDP synchronization.

Step 6 **dead-interval** *seconds*

Example:

```
RP/0/RP0/CPU0:router(config-ospf)# dead-interval 60
```

Sets the time to wait for a hello packet from a neighbor before declaring the neighbor down.

Step 7 **hello-interval** *seconds*

Example:

```
RP/0/RP0/CPU0:router(config-ospf)# hello-interval 15
```

Specifies the interval between hello packets that OSPF sends on the interface.

Step 8 **area** *area-id*

Example:

```
RP/0/RP0/CPU0:router(config-ospf)# area 0
```

Enters area configuration mode and configures an area for the OSPF process.

Step 9 **interface tunnel-ip** *number*

Example:

```
RP/0/RP0/CPU0:router(config-ospf)# interface tunnel-ip 4
```

Enters tunnel interface configuration mode.

- number is the number associated with the tunnel interface.

Step 10 Use the **commit** or **end** command.

commit - Saves the configuration changes and remains within the configuration session.

end - Prompts user to take one of these actions:

- **Yes** - Saves configuration changes and exits the configuration session.
- **No** - Exits the configuration session without committing the configuration changes.
- **Cancel** - Remains in the configuration mode, without committing the configuration changes.

Configuring LDP/GRE on the Provider Edge Routers

Perform this task to configure LDP/GRE on the provider edge routers.

SUMMARY STEPS

1. **configure**
2. **mpls ldp**
3. **router-id** { *router-id* }
4. **discovery hello holdtime** *seconds*
5. **discovery hello interval** *seconds*
6. **nsr**
7. **graceful-restart**
8. **graceful-restart reconnect-timeout** *seconds*
9. **graceful-restart forwarding-state-holdtime** *seconds*
10. **holdtime** *seconds*
11. **neighbor** *ip-address*
12. **interface tunnel-ip** *number*
13. Use the **commit** or **end** command.

DETAILED STEPS

Step 1 **configure**

Example:

```
RP/0/RP0/CPU0:router# configure
```

Enters the Global Configuration mode.

Step 2 **mpls ldp**

Example:

```
RP/0/RP0/CPU0:router(config)# mpls ldp
```

Enables MPLS LDP configuration mode.

Step 3 `router-id { router-id }`**Example:**

```
RP/0/RP0/CPU0:router(config-ldp)# router-id 10.0.0.1
```

Configures a router ID for the OSPF process.

Note We recommend using a stable IP address as the router ID.

Step 4 `discovery hello holdtime seconds`**Example:**

```
RP/0/RP0/CPU0:router(config-ldp)# discovery hello holdtime 40
```

Defines the period of time a discovered LDP neighbor is remembered without receipt of an LDP Hello message from the neighbor.

Note We recommend using a stable IP address as the router ID.

Step 5 `discovery hello interval seconds`**Example:**

```
RP/0/RP0/CPU0:router(config-ldp)# discovery hello holdtime 20
```

Defines the period of time between the sending of consecutive Hello messages.

Step 6 `nsr`**Example:**

```
RP/0/RP0/CPU0:router(config-ldp)# nsr
```

Activates BGP NSR.

Step 7 `graceful-restart`**Example:**

```
RP/0/RP0/CPU0:router(config-ldp)# graceful-restart
```

Enables graceful restart on the router.

Step 8 `graceful-restart reconnect-timeout seconds`**Example:**

```
RP/0/RP0/CPU0:router(config-ldp)# graceful-restart reconnect-timeout 180
```

Defines the time for which the neighbor should wait for a reconnection if the LDP session is lost.

Step 9 `graceful-restart forwarding-state-holdtime seconds`**Example:**

```
RP/0/RP0/CPU0:router(config-ldp)# graceful-restart forwarding-state-holdtime 300
```

Defines the time that the neighbor should retain the MPLS forwarding state during a recovery.

Step 10 **holdtime** *seconds***Example:**

```
RP/0/RP0/CPU0:router(config-ldp)# holdtime 90
```

Configures the hold time for an interface.

Step 11 **neighbor** *ip-address***Example:**

```
RP/0/RP0/CPU0:router(config-ldp)# neighbor 10.1.1.0
```

Defines a neighboring router.

Step 12 **interface tunnel-ip** *number***Example:**

```
RP/0/RP0/CPU0:router(config-ldp)# interface tunnel-ip 4
```

Enters tunnel interface configuration mode.

- **number** is the number associated with the tunnel interface.

Step 13 Use the **commit** or **end** command.

commit - Saves the configuration changes and remains within the configuration session.

end - Prompts user to take one of these actions:

- **Yes** - Saves configuration changes and exits the configuration session.
- **No** - Exits the configuration session without committing the configuration changes.
- **Cancel** - Remains in the configuration mode, without committing the configuration changes.

Configuring L3VPN

Perform this task to configure L3VPN.

SUMMARY STEPS

1. **configure**
2. **vrf** *vrf-name*
3. **address-family** { **ipv4** | **ipv6** } **unicast**
4. **import route-target** [*as-number:nn* | *ip-address:nn*]
5. **export route-target** [*as-number:nn* | *ip-address:nn*]
6. **interface** *type interface-path-id*
7. **vrf** *vrf-name*
8. **ipv4 address** *ipv4-address subnet-mask*
9. **dot1q native vlan** *vlan-id*
10. **router bgp** *as-number*
11. **nsr**

12. **bgp router-id** *ip-address*
13. **address-family** { *vpn4* | *vpn6* } **unicast**
14. **neighbor** *ip-address*
15. **remote-as** *as-number*
16. **update-source** *type interface-path-id*
17. **address-family** { *vpn4* | *vpn6* } **unicast**
18. **route-policy** *route-policy-name* **in**
19. **route-policy** *route-policy-name* **out**
20. **vrf** *vrf-name*
21. **rd** { *as-number:nn* | *ip-address:nn* | **auto** }
22. **address-family** { *ipv4* | *ipv6* } **unicast**
23. **redistribute connected** [**metric** *metric-value*] [*route-policy route-policy-name*]
24. **redistribute static** [**metric** *metric-value*] [*route-policy route-policy-name*]
25. **neighbor** *ip-address*
26. **remote-as** *as-number*
27. **ebg-multihop** *ttl-value*
28. **address-family** { *ipv4* | *ipv6* } **unicast**
29. **route-policy** *route-policy-name* **in**
30. **route-policy** *route-policy-name* **out**
31. Use the **commit** or **end** command.

DETAILED STEPS

Step 1 **configure**

Example:

```
RP/0/RP0/CPU0:router# configure
```

Enters the Global Configuration mode.

Step 2 **vrf** *vrf-name*

Example:

```
RP/0/RP0/CPU0:router(config)# vrf vpn1
```

Configures a VRF instance.

Step 3 **address-family** { *ipv4* | *ipv6* } **unicast**

Example:

```
RP/0/RP0/CPU0:router(config-vrf)# address-family { ipv4 | ipv6 } unicast
```

Specifies either the IPv4 or IPv6 address family and enters address family configuration submenu.

Step 4 **import route-target** [*as-number:nn* | *ip-address:nn*]

Example:

```
RP/0/RP0/CPU0:router(config-vrf)# import route-target 2:1
```

Specifies a list of route target (RT) extended communities. Only prefixes that are associated with the specified import route target extended communities are imported into the VRF.

Step 5 **export route-target** [*as-number:nn* | *ip-address:nn*]

Example:

```
RP/0/RP0/CPU0:router(config-vrf)# export route-target 1:1
```

Specifies a list of route target extended communities. Export route target communities are associated with prefixes when they are advertised to remote PEs. The remote PEs import them into VRFs which have import RTs that match these exported route target communities.

Step 6 **interface** *type interface-path-id*

Example:

```
RP/0/RP0/CPU0:router(config)# interface TenGigE0/2/0/0.1
```

Enters interface configuration mode and configures an interface.

Step 7 **vrf** *vrf-name*

Example:

```
RP/0/RP0/CPU0:router(config-if)# vrf vpn1
```

Configures a VRF instance.

Step 8 **ipv4 address** *ipv4-address subnet-mask*

Example:

```
RP/0/RP0/CPU0:router(config-if)# ipv4 address 172.16.0.1 255.240.0.0
```

Specifies the IPv4 address and subnet mask for the interface.

- *ipv4-address* specifies the IP address of the interface.
- *subnet-mask* specifies the subnet mask of the interface.

Step 9 **dot1q native vlan** *vlan-id*

Example:

```
RP/0/RP0/CPU0:router(config-if)# dot1q native  
vlan 1
```

Assigns the native VLAN ID of a physical interface trunking 802.1Q VLAN traffic.

Step 10 **router bgp** *as-number*

Example:

```
RP/0/RP0/CPU0:router(config)# router bgp 1
```

Specifies the autonomous system number and enters the BGP configuration mode, allowing you to configure the BGP routing process.

Step 11 **nsr****Example:**

```
RP/0/RP0/CPU0:router(config-bgp)# nsr
```

Activates BGP NSR.

Step 12 **bgp router-id** *ip-address***Example:**

```
RP/0/RP0/CPU0:router(config-bgp)# bgp router-id 10.0.0.1
```

Configures the local router with a specified router ID.

Step 13 **address-family** { *vpn4* | *vpn6* } **unicast****Example:**

```
RP/0/RP0/CPU0:router(config-bgp)# address-family vpn4 unicast
```

Enters address family configuration submode for the specified address family.

Step 14 **neighbor** *ip-address***Example:**

```
RP/0/RP0/CPU0:router(config-bgp)# neighbor 192.168.0.1
```

Places the router in neighbor configuration mode for BGP routing and configures the neighbor IP address as a BGP peer.

Step 15 **remote-as** *as-number***Example:**

```
RP/0/RP0/CPU0:router(config-bgp-nbr)#remote-as 1
```

Creates a neighbor and assigns a remote autonomous system number to it..

Step 16 **update-source** *type interface-path-id***Example:**

```
RP/0/RP0/CPU0:router(config-bgp-nbr)#update-source Loopback0
```

Allows sessions to use the primary IP address from a specific interface as the local address when forming a session with a neighbor.

Step 17 **address-family** { *vpn4* | *vpn6* } **unicast****Example:**

```
RP/0/RP0/CPU0:router(config-bgp-nbr)# address-family vpn4 unicast
```

Enters address family configuration submode for the specified address family.

Step 18 **route-policy** *route-policy-name* **in****Example:**

```
RP/0/RP0/CPU0:router(config-bgp-nbr-af)#route-policy pass-all in
```

Defines a route policy and enters route policy configuration mode.

Step 19 **route-policy** *route-policy-name* **out**

Example:

```
RP/0/RP0/CPU0:router(config-bgp-nbr-af)#route-policy pass-all out
```

Defines a route policy and enters route policy configuration mode.

Step 20 **vrf** *vrf-name*

Example:

```
RP/0/RP0/CPU0:router(config)# vrf vpn1
```

Configures a VRF instance.

Step 21 **rd** { *as-number:nn* | *ip-address:nn* | **auto** }

Example:

```
RP/0/RP0/CPU0:router(config-vrf)#rd 1:1
```

Configures the route distinguisher.

Step 22 **address-family** { *ipv4* | *ipv6* } **unicast**

Example:

```
RP/0/RP0/CPU0:router(config-vrf)# address-family ipv4 unicast
```

Specifies either the IPv4 or IPv6 address family and enters address family configuration submode.

Step 23 **redistribute connected** [**metric** *metric-value*] [*route-policy route-policy-name*]

Example:

```
RP/0/RP0/CPU0:router(config-vrf-af)#
redistribute connected
```

Configures the local router with a specified router ID.

Step 24 **redistribute static** [**metric** *metric-value*] [*route-policy route-policy-name*]

Example:

```
RP/0/RP0/CPU0:router(config-vrf-af)#
redistribute static
```

Causes routes from the specified instance to be redistributed into BGP.

Step 25 **neighbor** *ip-address*

Example:

```
RP/0/RP0/CPU0:router(config-bgp)# neighbor 172.16.0.2
```

Places the router in neighbor configuration mode for BGP routing and configures the neighbor IP address as a BGP peer.

Step 26 **remote-as** *as-number*

Example:

```
RP/0/RP0/CPU0:router(config-bgp-nbr)#remote-as 7501
```

Creates a neighbor and assigns a remote autonomous system number to it..

Step 27 **ebg-multihop** *ttl-value*

Example:

```
RP/0/RP0/CPU0:router(config-bgp-nbr)
#ebgp-multihop 10
```

Configures the CE neighbor to accept and attempt BGP connections to external peers residing on networks that are not directly connected.

Step 28 **address-family { ipv4 | ipv6 } unicast**

Example:

```
RP/0/RP0/CPU0:router(config-bgp-nbr)# address-family ipv4 unicast
```

Specifies either the IPv4 or IPv6 address family and enters address family configuration submode.

Step 29 **route-policy** *route-policy-name in*

Example:

```
RP/0/RP0/CPU0:router(config-bgp-nbr-af)#route-policy
BGP_pass_all in
```

Configures the local router with a specified router.

Step 30 **route-policy** *route-policy-name out*

Example:

```
RP/0/RP0/CPU0:router(config-bgp-nbr-af)#route-policy BGP_pass_all out
```

Defines a route policy and enters route policy configuration mode.

Step 31 Use the **commit** or **end** command.

commit - Saves the configuration changes and remains within the configuration session.

end - Prompts user to take one of these actions:

- **Yes** - Saves configuration changes and exits the configuration session.
- **No** - Exits the configuration session without committing the configuration changes.
- **Cancel** - Remains in the configuration mode, without committing the configuration changes.

Configuring 6VPE Support

The following tasks are required to configure 6VPE support:

Configuring an IPv6 Address Family Under VRF

Perform this task to configure an IPv6 address-family under the VRF for 6VPE support.



Note You can also configure a maximum-routes limit for the VRF, export, and import policies.

SUMMARY STEPS

1. **configure**
2. **vrf** *vrf-name*
3. **address-family ipv6 unicast**
4. **import route-target** [*as-number:nn* | *ip-address:nn*]
5. **export route-target** [*as-number:nn* | *ip-address:nn*]
6. Use the **commit** or **end** command.

DETAILED STEPS

Step 1 **configure**

Example:

```
RP/0/RP0/CPU0:router# configure
```

Enters the Global Configuration mode.

Step 2 **vrf** *vrf-name*

Example:

```
RP/0/RP0/CPU0:router(config)# vrf vrf_1
```

Configures a VRF instance and enters VRF configuration mode.

Step 3 **address-family ipv6 unicast**

Example:

```
RP/0/RP0/CPU0:router(config-vrf)# address-family ipv4 unicast
```

Enters VRF address family configuration mode for the IPv6 address family.

Step 4 **import route-target** [*as-number:nn* | *ip-address:nn*]

Example:

```
RP/0/RP0/CPU0:router(config-vrf-af)# import route-target 120:1
```

Configures a VPN routing and forwarding (VRF) import route-target extended community.

Step 5 **export route-target** [*as-number:nn* | *ip-address:nn*]

Example:

```
RP/0/RP0/CPU0:router(config-vrf-af)# export route-target 120:2
```

Associates the local VPN with a route target. When the route is advertised to other provider edge (PE) routers, the export route target is sent along with the route as an extended community.

Step 6 Use the **commit** or **end** command.

commit - Saves the configuration changes and remains within the configuration session.

end - Prompts user to take one of these actions:

- **Yes** - Saves configuration changes and exits the configuration session.
- **No** - Exits the configuration session without committing the configuration changes.
- **Cancel** - Remains in the configuration mode, without committing the configuration changes.

Configuring BGP Route Distinguisher and Core-facing Sessions

Perform this task to configure VRF route distinguisher values and core-facing neighbors under BGP.



Note Before you perform this task, you must first configure a VRF and map the VRF to an interface. For more information, see [Implementing MPLS VPNs over IP Tunnels](#) on Cisco IOS XR Software.

SUMMARY STEPS

1. **configure**
2. **router bgp** *as-number*
3. **address-family ipv6 unicast**
4. **vrf** *vrf-name*
5. **rd** { *as-number:nn* | *ip-address:nn* **auto** }
6. **address-family ipv6 unicast**
7. **exit**
8. **neighbor** *ip-address* **remote-as** *as-number*
9. **address-family ipv6 unicast**
10. Use the **commit** or **end** command.

DETAILED STEPS

Step 1 **configure**

Example:

```
RP/0/RSP0/CPU0:router# configure
```

Enters the Global Configuration mode.

Step 2 **router bgp *as-number*****Example:**

```
RP/0/RP0/CPU0:router(config)# router bgp 100  
RP/0/RP0/CPU0:router(config-bgp)#
```

Enters router BGP configuration mode.

Step 3 **address-family ipv6 unicast****Example:**

```
RP/0/RP0/CPU0:router(config-bgp)# address-family vpnv6 unicast  
RP/0/RP0/CPU0:router(config-bgp-af)
```

Enters address family configuration mode for the VPNv6 address family.

Step 4 **vrf *vrf-name*****Example:**

```
RP/0/RP0/CPU0:router(config-bgp)# vrf red
```

Configures a VPN VRF instance and enters VRF configuration mode.

Step 5 **rd { *as-number:nn* | *ip-address:nn* **auto** }****Example:**

```
RP/0/RP0/CPU0:router(config-bgp-vrf)# router bgp 100
```

Configures a route distinguisher.

Step 6 **address-family ipv6 unicast****Example:**

```
RP/0/RP0/CPU0:router(config-bgp-vrf)# address-family ipv6 unicast
```

Enters IPv6 address family configuration mode.

Step 7 **exit****Example:**

```
RP/0/RP0/CPU0:router(config-bgp-vrf-af)# exit
```

Exits the current configuration mode.

Step 8 **neighbor *ip-address* **remote-as** *as-number*****Example:**

```
RP/0/RP0/CPU0:router(config-bgp-vrf)# neighbor 172.168.40.24 remote-as 2002f
```

Creates a neighbor and assigns it a remote autonomous system number.

Step 9 **address-family ipv6 unicast**

Example:

```
RP/0/RP0/CPU0:router(config-bgp-vrf)# address-family ipv6 unicast
```

Enters IPv6 address family configuration mode.

Step 10 Use the **commit** or **end** command.

commit - Saves the configuration changes and remains within the configuration session.

end - Prompts user to take one of these actions:

- **Yes** - Saves configuration changes and exits the configuration session.
- **No** - Exits the configuration session without committing the configuration changes.
- **Cancel** - Remains in the configuration mode, without committing the configuration changes.

Configuring a PE-CE Protocol

Perform this task to configure a PE-CE protocol for 6VPE.



Note eBGP, iBGP and eiBGP load-balancing configuration options are also supported for 6VPE.

SUMMARY STEPS

1. **configure**
2. **router bgp** *as-number*
3. **vrf** *vrf-name*
4. **address-family ipv6 unicast**
5. **exit**
6. **exit**
7. **neighbor** *ip-address*
8. **remote-as** *as-number*
9. **address-family vpnv6 unicast**
10. **route-policy** *route-policy-name* **in**
11. Use the **commit** or **end** command.

DETAILED STEPS

Step 1 **configure**

Example:

```
RP/0/RP0/CPU0:router# configure
```

Enters the Global Configuration mode.

Step 2 **router bgp *as-number***

Example:

```
RP/0/RP0/CPU0:router(config)# router bgp 120
RP/0/RP0/CPU0:router(config-bgp)
```

Enters router BGP configuration mode.

Step 3 **vrf *vrf-name***

Example:

```
RP/0/RP0/CPU0:router(config-bgp)# vrf red
RP/0/RP0/CPU0:router(config-bgp-vrf)
```

Configures a VPN VRF instance and enters VRF configuration mode.

Step 4 **address-family ipv6 unicast**

Example:

```
RP/0/RP0/CPU0:router(config-bgp-vrf) address-family ipv6 unicast
RP/0/RP0/CPU0:router(config-bgp-vrf-af)
```

Enters IPv6 address family configuration mode.

Step 5 **exit**

Example:

```
RP/0/RP0/CPU0:router(config-bgp-vrf-af)# exit
```

Exits the current configuration mode.

Step 6 **exit**

Example:

```
RP/0/RP0/CPU0:router(config-bgp-vrf)# exit
```

Exits the current configuration mode.

Step 7 **neighbor *ip-address***

Example:

```
RP/0/RP0/CPU0:router(config-bgp)# neighbor 10,10.10,10
```

Creates a neighbor and assigns it a remote autonomous system number of 2002.

Step 8 **remote-as** *as-number***Example:**

```
RP/0/RP0/CPU0:router(config-bgp-nbr)# remote-as 1000
```

Creates a BGP neighbor and begin the exchange of routing information.

Step 9 **address-family vpnv6 unicast****Example:**

```
RP/0/RP0/CPU0:router(config-bgp-nbr)# address-family vpnv6 unicast
RP/0/RP0/CPU0:router(config-bgp-nbr-af)
```

Enters address family configuration mode for the VPNv6 address family.

Step 10 **route-policy** *route-policy-name in***Example:**

```
RP/0/RP0/CPU0:router(config-bgp-nbr-af)# route-policy In-Ipv4 in
```

Applies a routing policy to updates advertised to or received from a BGP neighbor.

Step 11 Use the **commit** or **end** command.

commit - Saves the configuration changes and remains within the configuration session.

end - Prompts user to take one of these actions:

- **Yes** - Saves configuration changes and exits the configuration session.
- **No** - Exits the configuration session without committing the configuration changes.
- **Cancel** - Remains in the configuration mode, without committing the configuration changes.

Configuration Examples for Implementing MPLS Layer 3 VPNs

The following section provides sample configurations for MPLS L3VPN features:

Configuring an MPLS VPN Using BGP: Example

The following example shows the configuration for an MPLS VPN using BGP on “vrf vpn1”:

```
address-family ipv4 unicast
  import route-target
    100:1
  !
  export route-target
    100:1
  !
!
!
route-policy pass-all
```

```

    pass
end-policy
!
interface Loopback0
  ipv4 address 10.0.0.1 255.255.255.255
!
interface TenGigE 0/1/0/0
  vrf vpn1
  ipv4 address 10.0.0.2 255.0.0.0
!
interface TenGigE 0/1/0/1
  ipv4 address 10.0.0.1 255.0.0.0
!
router ospf 100
  area 100
    interface loopback0
    interface TenGigE 0/1/0/1
  !
!
router bgp 100
  address-family vpnv4 unicast
  retain route-target route-policy policy1
  neighbor 10.0.0.3
  remote-as 100
  update-source Loopback0
  address-family vpnv4 unicast
!
vrf vpn1
  rd 100:1
  address-family ipv4 unicast
  redistribute connected
  !
  neighbor 10.0.0.1
  remote-as 200
  address-family ipv4 unicast
  as-override
  route-policy pass-all in
  route-policy pass-all out
  !
  advertisement-interval 5
  !
!
!
mpls ldp
  route-id loopback0
  interface TenGigE 0/1/0/1
!

```

Configuring the Routing Information Protocol on the PE Router: Example

The following example shows the configuration for the RIP on the PE router:

```

vrf vpn1
  address-family ipv4 unicast
  import route-target
  100:1
  !
  export route-target
  100:1
  !
!
!
route-policy pass-all

```

```

    pass
end-policy
!

interface TenGigE 0/1/0/0
 vrf vpn1
  ipv4 address 10.0.0.2 255.0.0.0
!

router rip
 vrf vpn1
  interface TenGigE 0/1/0/0
  !
  timers basic 30 90 90 120
  redistribute bgp 100
  default-metric 3
  route-policy pass-all in
!
```

Configuring the PE Router Using EIGRP: Example

The following example shows the configuration for the Enhanced Interior Gateway Routing Protocol (EIGRP) on the PE router:

```

Router eigrp 10
 vrf VRF1
  address-family ipv4
    router-id 10.1.1.2
    default-metric 100000 2000 255 1 1500
    as 62
    redistribute bgp 2000
  interface Loopback0
  !
  interface TenGigE 0/6/0/0
```

Configuration Examples for MPLS VPN CSC

Configuration examples for the MPLS VPN CSC include:

Configuring the Backbone Carrier Core: Examples

Configuration examples for the backbone carrier core included in this section are as follows:

Configuring VRFs for CSC-PE Routers: Example

The following example shows how to configure a VPN routing and forwarding instance (VRF) for a CSC-PE router:

```

config
 vrf vpn1
  address-family ipv4 unicast
    import route-target 100:1
    export route-target 100:1
end
```

Configuring the Links Between CSC-PE and CSC-CE Routers: Examples

This section contains the following examples:

Configuring a CSC-PE: Example

In this example, a CSC-PE router peers with a PE router, 10.1.0.2, in its own AS. It also has a labeled unicast peering with a CSC-CE router, 10.0.0.1.

```
config
router bgp 2
  address-family vpnv4 unicast
  neighbor 10.1.0.2
    remote-as 2
  update-source loopback0
  address-family vpnv4 unicast
  vrf customer-carrier
  rd 1:100
  address-family ipv4 unicast
    allocate-label all
    redistribute static
  neighbor 10.0.0.1
    remote-as 1
  address-family ipv4 labeled-unicast
    route-policy pass-all in
    route-policy pass-all out
  as-override
end
```

Configuring a CSC-CE: Example

The following example shows how to configure a CSC-CE router. In this example, the CSC-CE router peers with a CSC-PE router 10.0.0.2 in AS 2.

```
config
router bgp 1
  address-family ipv4 unicast
    redistribute ospf 200
    allocate-label all
  neighbor 10.0.0.2
    remote-as 2
  address-family ipv4 labeled-unicast
    route-policy pass-all in
    route-policy pass-all out
end
```

Configuring a Static Route to a Peer: Example

The following example shows how to configure a static route to an Inter-AS or CSC-CE peer:

```
config
router static
  address-family ipv4 unicast
  10.0.0.2/32 172.16.0.1
end
```

Configuring a Static Route to a Peer: Example

This example shows how to configure a static route to an Inter-AS or CSC-CE peer:

```

config
router static
  address-family ipv4 unicast
    10.0.0.2/32 40.1.1.1
end

```

Configuring L3VPN over GRE: Example

The following example shows how to configure L3VPN over GRE:

Sample configuration to create a GRE tunnel between PE1 and PE2:

```

RP/0/RSP0/CPU0:PE1#sh run int tunnel-ip 1
interface tunnel-ip1
  ipv4 address 172.16.0.1 255.240.0.0
  ipv6 address 100:1:1:1::1/64
  tunnel mode gre ipv4
  tunnel source TenGigE0/2/0/1
  tunnel destination 145.12.5.2
!
RP/0/RSP0/CPU0:PE2#sh run int tunnel-ip 1
interface tunnel-ip1
  ipv4 address 172.16.0.2 255.240.0.0
  ipv6 address 100:1:1:1::2/64
  tunnel mode gre ipv4
  tunnel source TenGigE0/1/0/2
  tunnel destination 192.168.0.1

```

Configure IGP between PE1 and PE2:

Sample configuration for PE1 is given below. PE2 will also have a similar configuration.

```

RP/0/RSP0/CPU0:PE1#sh run router ospf 1
router ospf 1
  nsr
  router-id 10.0.0.1 <=== Loopback0
  mpls ldp sync
  mtu-ignore enable
  dead-interval 60
  hello-interval 15
  area 0
    interface TenGigE0/2/0/1
    !
RP/0/RSP0/CPU0:PE1#sh run router ospf 0
router ospf 0
  nsr
  router-id 10.0.0.1
  mpls ldp sync
  dead-interval 60
  hello-interval 15
  area 0
    interface Loopback0
    !
    interface tunnel-ip1
    !

* Check for OSPF neighbors

RP/0/RSP0/CPU0:PE1#sh ospf neighbor

```

Neighbors for OSPF 0

Neighbor ID	Pri	State	Dead Time	Address	Interface	
4.4.4.4	1	FULL/ -	00:00:47	172.16.0.2	tunnel-ip1	<==

Neighbor PE2

Neighbor is up for 00:13:40

Neighbors for OSPF 1

Neighbor ID	Pri	State	Dead Time	Address	Interface	
2.2.2.2	1	FULL/DR	00:00:50	192.168.0.1	TenGigE0/2/0/1	<==

Neighbor P1

Neighbor is up for 00:13:43

Configure LDP/GRE on PE1 and PE2:

```
RP/0/RSP0/CPU0:PE1#sh run mpls ldp
mpls ldp
router-id 10.0.0.1 <=== Loopback0
discovery hello holdtime 45
discovery hello interval 15
nsr
graceful-restart
graceful-restart reconnect-timeout 180
graceful-restart forwarding-state-holdtime 300
holdtime 90
log
neighbor
!
interface tunnel-ip1
!
```

*Check for mpls forwarding

```
RP/0/RSP0/CPU0:PE1#sh mpls forwarding prefix 10.0.0.2/8
Local  Outgoing  Prefix          Outgoing  Next Hop      Bytes
Label  Label      or ID          Interface  Interface     Switched
-----
16003  Pop        10.0.0.2/8    ti1        172.16.0.2    0
```

Configure L3VPN

```
RP/0/RSP0/CPU0:PE1#sh run vrf vpn1
vrf vpn1
address-family ipv4 unicast
import route-target
2:1
!
export route-target
1:1
!
RP/0/RSP0/CPU0:PE1#sh run int tenGigE 0/2/0/0.1
interface TenGigE0/2/0/0.1
vrf vpn1
ipv4 address 172.16.0.1 255.255.255.0
encapsulation dot1q 1
!
```

```

RP/0/RSP0/CPU0:PE1#sh run router bgp
router bgp 1
  nsr
  bgp router-id 10.0.0.1 <===Loopback0
  address-family vpnv4 unicast
  !
  neighbor 192.168.0.1 <===iBGP session with PE2
  remote-as 1
  update-source Loopback0
  address-family vpnv4 unicast
    route-policy pass-all in
    route-policy pass-all out
  !
  !
  vrf vpn1
  rd 1:1
  address-family ipv4 unicast
    redistribute connected
    redistribute static
  !
  neighbor 172.16.0.2 <=== VRF neighbor
  remote-as 7501
  ebgp-multihop 10
  address-family ipv4 unicast
    route-policy BGP_pass_all in
    route-policy BGP_pass_all out
  !

* Check vrf ping to the 172.16.0.2

RP/0/RSP0/CPU0:PE1#ping vrf vpn1 172.16.0.2
Type escape sequence to abort.
Sending 5, 100-byte ICMP Echos to 172.16.0.2, timeout is 2 seconds:
!!!!
Success rate is 100 percent (5/5), round-trip min/avg/max = 1/1/3 ms

* Send traffic to vrf routes advertised and verify that mpls counters increase in tunnel
interface accounting

RP/0/RSP0/CPU0:PE1#sh int tunnel-ipl accounting
tunnel-ipl
  Protocol          Pkts In          Chars In          Pkts Out          Chars Out
  IPV4_MULTICAST    3                 276                3                 276
  MPLS              697747           48842290          0                 0

```

Configuration Examples for 6VPE

Configuration examples for the MPLS VPN CSC include:

Configuring an IPv6 Address Family Under VRF: Example

The following example shows a standard configuration of an IPv6 address family under VRF:

```

configure
vrf red
  address-family ipv6 unicast
    import route-target
    500:1
  !
  export route-target

```

```

    500:1
    !
    !

```

Configuring BGP for the Address Family VPNv6: Example

The following example shows the configuration for the address family VPNv6 under the PE peer:

```

configure
router bgp 3
  address-family vpnv6 unicast
  !
  neighbor 192.168.254.3
  remote-as 3
  update-source Loopback0
  address-family ipv4 unicast
  !
  address-family vpnv4 unicast
  !
  address-family ipv6 labeled-unicast
  !
  address-family vpnv6 unicast
  !
  !

```

Configuring the Address Family IPv6 for the VRF Configuration Under BGP: Example

The following example shows the configuration for the address family IPv6 for the VRF configuration under BGP:

```

!
vrf red
  address-family ipv6 unicast
  redistribute connected
  !

```

Configuring a PE-CE Protocol: Example

The following example shows the eBGP configuration of a PE-CE protocol:

```

!
neighbor 2001:db80:cafe:1::2
  remote-as 100
  address-family ipv6 unicast
  route-policy pass in
  route-policy pass out

```

Configuring an Entire 6VPE Configuration: Example

Two VPNs, which are named red and blue, are created across router2 and router4. The VRF red is for the user running IPv6 addressing in the network. The VRF blue is for the user running IPv4 addressing. 6VPE is implemented to carry the VPNv6 prefixes across to the other PE.

The following example shows the entire 6VPE configuration that includes the interface and VRF configurations of both PE routers across the route reflectors:

```

router2 (PE router)
interface GigabitEthernet0/0/1/3.1
  vrf red
  ipv4 address 192.3.1.1 255.255.255.0
  ipv6 address 2001:db80:cafe:1::1/64

```

```

dot1q vlan 2
!

show run interface gigabitEthernet 0/0/1/3.2
interface GigabitEthernet0/0/1/3.2
 vrf blue
  ipv4 address 192.3.2.1 255.255.255.0
  dot1q vlan 3
!

vrf red
  address-family ipv4 unicast
    import route-target
      500:1
    !
    export route-target
      500:1
    !
  !
  address-family ipv6 unicast
    import route-target
      500:1
    !
    export route-target
      500:1
  !
!
!
vrf blue
  address-family ipv4 unicast
    import route-target
      600:1
    !
    export route-target
      600:1
  !
!

router bgp 3
  address-family ipv4 unicast
    network 3.3.3.3/32
  !
  address-family vpnv4 unicast
  !
  address-family ipv6 unicast
    network 2001:db82:cafe:1::/64
    allocate-label all
  !
  address-family vpnv6 unicast
  !
  neighbor 192.168.253.4
  remote-as 3
  update-source Loopback0
  address-family ipv4 unicast
  !
  address-family vpnv4 unicast
  !
  address-family ipv6 labeled-unicast
  !

```

```
address-family vpnv6 unicast
!
!
neighbor 192.168.254.3
 remote-as 3
 update-source Loopback0
 address-family ipv4 unicast
!
 address-family vpnv4 unicast
!
 address-family ipv6 labeled-unicast
!
address-family vpnv6 unicast
!
!
vrf red
 rd 500:1
 address-family ipv4 unicast
  redistribute connected
!
 address-family ipv6 unicast
  redistribute connected
!
 neighbor 2001:db80:cafe:1::2
  remote-as 100
  address-family ipv6 unicast
  route-policy pass in
  route-policy pass out
!
!
vrf blue
 rd 600:1
 address-family ipv4 unicast
  redistribute connected
!
!
!

router3 (RR)

router bgp 3
 bgp router-id 192.168.253.4
 address-family ipv4 unicast
!
 address-family vpnv4 unicast
!
 address-family ipv6 unicast
!
 address-family vpnv6 unicast
!
 neighbor-group all
  remote-as 3
  update-source Loopback0
  address-family ipv4 unicast
  route-reflector-client
!
 address-family vpnv4 unicast
  route-reflector-client
!
 address-family ipv6 labeled-unicast
  route-reflector-client
!
```

```

    address-family vpnv6 unicast
      route-reflector-client
    !
    !
    neighbor 192.168.253.1
      use neighbor-group all
    !
    neighbor 192.168.253.2
      use neighbor-group all
    !
    neighbor 192.168.253.3
      use neighbor-group all
    !
    neighbor 192.168.253.5
      use neighbor-group all
    !
    neighbor 192.168.253.6
      use neighbor-group all
    !
    neighbor 192.168.254.3
      remote-as 3
      update-source Loopback0
      address-family ipv4 unicast
    !
    !
    !
  router4(PE router)

  vrf red
    address-family ipv4 unicast
      import route-target
        500:1
      !
      export route-target
        500:1
      !
    !
    address-family ipv6 unicast
      import route-target
        500:1
      !
      export route-target
        500:1
      !
    !
    !
  vrf blue
    address-family ipv4 unicast
      import route-target
        600:1
      !
      export route-target
        600:1
      !
    !
    !

  router bgp 3
    address-family ipv4 unicast
    !
    address-family vpnv4 unicast
    !

```



```

address-family ipv6 unicast
  network 2001:db84:beef:1::/64
  allocate-label all
!
address-family vpv6 unicast
!
neighbor 192.168.253.4
  remote-as 3
  update-source Loopback0
  address-family ipv4 unicast
!
  address-family vpv4 unicast
!
  address-family ipv6 labeled-unicast
!
  address-family vpv6 unicast
!
!
neighbor 192.168.254.3
  remote-as 3
  update-source Loopback0
  address-family ipv4 unicast
!
  address-family vpv4 unicast
!
  address-family ipv6 labeled-unicast
!
!
vrf red
  rd 500:1
  address-family ipv4 unicast
  redistribute connected
!
  address-family ipv6 unicast
  redistribute connected
!
!
vrf blue
  rd 600:1
  address-family ipv4 unicast
  redistribute connected
!
!
!

```

The following example displays the sample output for the entire 6VPE configuration:

```

show route vrf red ipv6

Codes: C - connected, S - static, R - RIP, M - mobile, B - BGP
       D - EIGRP, EX - EIGRP external, O - OSPF, IA - OSPF inter area
       N1 - OSPF NSSA external type 1, N2 - OSPF NSSA external type 2
       E1 - OSPF external type 1, E2 - OSPF external type 2, E - EGP
       i - ISIS, L1 - IS-IS level-1, L2 - IS-IS level-2
       ia - IS-IS inter area, su - IS-IS summary null, * - candidate default
       U - per-user static route, o - ODR, L - local

Gateway of last resort is not set

C    2001:db80:beef:1::/64 is directly connected,
     19:09:50, GigabitEthernet0/0/1/3.1
L    2001:db80:beef:1::1/128 is directly connected,
     19:09:50, GigabitEthernet0/0/1/3.1
B    2001:db80:cafe:1::/64
     [200/0] via ::ffff:192.168.253.3 (nexthop in vrf default), 07:03:40

```

```
show route vrf red ipv6
```

```
Codes: C - connected, S - static, R - RIP, M - mobile, B - BGP  
D - EIGRP, EX - EIGRP external, O - OSPF, IA - OSPF inter area  
N1 - OSPF NSSA external type 1, N2 - OSPF NSSA external type 2  
E1 - OSPF external type 1, E2 - OSPF external type 2, E - EGP  
i - ISIS, L1 - IS-IS level-1, L2 - IS-IS level-2  
ia - IS-IS inter area, su - IS-IS summary null, * - candidate default  
U - per-user static route, o - ODR, L - local
```

```
Gateway of last resort is not set
```

```
B 2001:db80:beef:1::/64  
  [200/0] via ::ffff:192.168.253.6 (nexthop in vrf default), 07:04:14  
C 2001:db80:cafe:1::/64 is directly connected,  
  08:28:12, GigabitEthernet0/0/1/3.1  
L 2001:db80:cafe:1::1/128 is directly connected,  
  08:28:12, GigabitEthernet0/0/1/3.1
```