



# Power Supply Installation

This chapter describes how to remove and install a new or replacement power supply. Your router ships with at least one installed power-supply module (AC or DC, depending on your order).

The power-supply modules are field-replaceable units (FRUs) and are hot-swappable when deployed in non-hazardous locations.

- [Power Supply Installation, on page 1](#)
- [Power-Supply Modules, on page 1](#)
- [Power-Supply Module Installation, on page 3](#)
- [Removing the Power Supply Module, on page 12](#)

## Power Supply Installation

This chapter describes how to remove and install a new or replacement power supply. Your router ships with at least one installed power-supply module (AC or DC, depending on your order).

The power-supply modules are field-replaceable units (FRUs) and are hot-swappable when deployed in non-hazardous locations.

## Power-Supply Modules

The following table lists the supported power supply modules. For detailed specifications, see the data sheet.

**Table 1: Power Supply Modules**

Model	Description
PWR-RGD-AC-DC	High-voltage AC or DC, 100-240VAC 50-60Hz/100-250VDC input, 150 watt output
PWR-RGD-LOW-DC	Low-voltage DC, 24-60VDC input, 150 watt output
PWR-RGD-AC-DC-250	High-voltage AC or DC, 100-240VAC 50-60Hz/100-250VDC input, 250 watt output

Figure 1: PWR-RGD-AC-DC Power-Supply Module

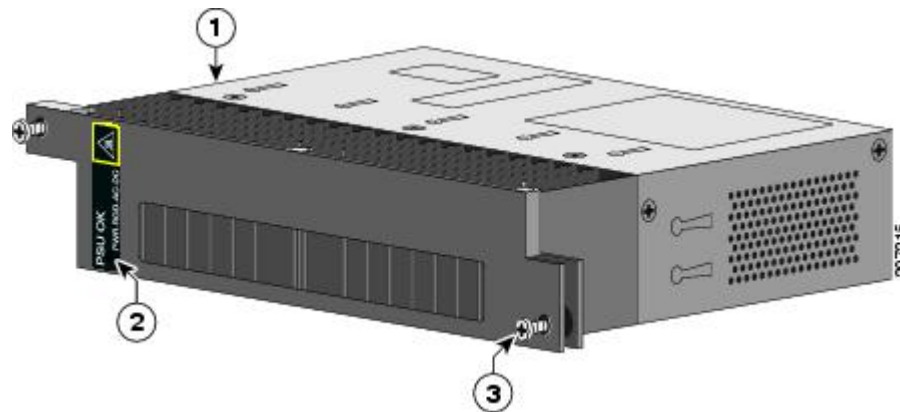

1	Power-supply module	3	Captive screw
2	PSU OK LED		

Figure 2: PWR-RGD-LOW-DC Power-Supply Module

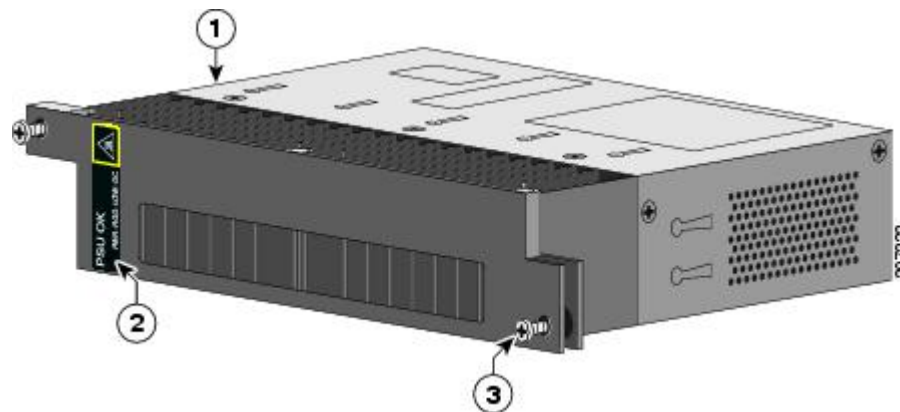

1	Power-supply module	3	Captive screw
2	PSU OK LED		

For a description of the PSU OK LEDs, see [Power-Supply Module LEDs](#), on page 2.

## Power-Supply Module LEDs

The router power-supply module LEDs are labeled PSU1 and PSU2 (on the router) and PSU OK (on the power-supply module). They show whether power-supply modules 1 and 2 are receiving power.

Table 2: Power Supply Module LEDs

Color	System Status
Off	Power-supply module (1 or 2) is not installed.

Color	System Status
Green	Valid input is present, and the output is within the operating range.
Red	Valid input is present, and the output is outside the operating range or is not present.
Blinking red	Power-supply module (1 or 2) is installed but valid input is not present.

# Power-Supply Module Installation

## Installation Guidelines

Observe these guidelines when removing or installing a power-supply module:

A power-supply module that is only partially connected to the router disrupts the system operation.



**Warning** Blank faceplates and cover panels serve three important functions: they prevent exposure to hazardous voltages and currents inside the chassis; they contain electromagnetic interference (EMI) that might disrupt other equipment; and they direct the flow of cooling air through the chassis. Do not operate the system unless all cards, faceplates, front covers, and rear covers are in place. Statement 1029



**Warning** Do not reach into a vacant slot while installing or removing a module. Exposed circuitry is an energy hazard. Statement 206



**Warning** Only trained and qualified personnel should be allowed to install, replace, or service this equipment. Statement 1030



**Warning** Avoid using or servicing any equipment that has outdoor connections during an electrical storm. There may be a risk of electric shock from lightning. Statement 1088

## Installing a Power-Supply Module

This procedure is for installing a power-supply module in the PSU1 or PSU2 slot.



**Warning** The covers are an integral part of the safety design of the product. Do not operate the unit without the covers installed. Statement 1077



---

**Warning** This unit might have more than one power supply connection. All connections must be removed to de-energize the unit. Statement 1028

---



---

**Caution** Equipment installation must comply with local and national electrical codes.

---

## Equipment That You Need

- Torque driver(s) capable of 5 to 35 in-lbs
- Ring, spade, or flanged spade terminal (terminals should be insulated)
  - Ring terminal (such as Tyco part number 2-34158-1 for 16– 14 AWG or 2-34852-1 for 12– 10 AWG wire)
  - Spade terminal (such as Tyco part number 54367-2 for 16– 14 AWG wire)
  - Flanged spade terminal (such as Tyco part number 2-324165-1 for 16– 14 AWG wire or 1-324581-1 for 12– 10 AWG wire)
- Use the 16-14 AWG wire and appropriate terminals for the AC or high-voltage DC power supply
- Use the 12-10 AWG wire and appropriate terminals for the low-voltage DC power supply
- Crimping tool (such as Thomas & Bett part number WT2000, ERG-2001)
- 6-gauge copper ground wire
- 12-AWG wire (minimum) for the low-voltage power-supply module and 16-AWG (minimum) wire for the high-voltage power-supply module
- For power source connections, use wires rated for at least 194°F (90°C).
- UL- and CSA-rated style 1007 or 1569 twisted-pair copper wire
- Wire-stripping tools for stripping 6-, 10-, 12-, 14-, and 16-gauge wires.
- Number-2 Phillips screwdriver
- Flat-blade screwdriver

## Grounding the router

Follow the grounding procedures at your site and observe these warnings:



---

**Warning** This equipment must be grounded. Never defeat the ground conductor or operate the equipment in the absence of a suitably installed ground conductor. Contact the appropriate electrical inspection authority or an electrician if you are uncertain that suitable grounding is available. Statement 1024

---



---

**Warning** When installing or replacing the unit, the ground connection must always be made first and disconnected last. Statement 1046

---



---

**Caution** Follow the grounding procedure instructions, and use an appropriately Listed or certified lug (included with the router) for number-6 AWG wire and 10-32 ground-lug screws.

---



**Note** You can use the grounding lug to attach a wrist strap for ESD protection during servicing.

Follow these steps to install a dual-hole lug on the router. Be sure to follow any grounding requirements at your site.

**Step 1** Use a Phillips screwdriver or a ratcheting torque screwdriver with a Phillips head to remove the ground screws from the cable side of the router. You need the screws in Step 4.

**Step 2** Strip the 6-gauge ground wire to 0.5 inch (12.7 mm)  $\pm$  0.02 inch (0.5 mm). See the following figure. Stripping more than the recommended amount of wire can leave exposed wire from the connector.

**Figure 3: Stripping the Ground Wire**

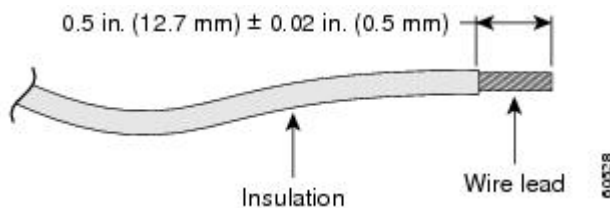

**Step 3** Insert the ground wire into the terminal lug, and crimp the terminal to the wire. (see the following figure).

**Figure 4: Crimping the Terminal Lug**

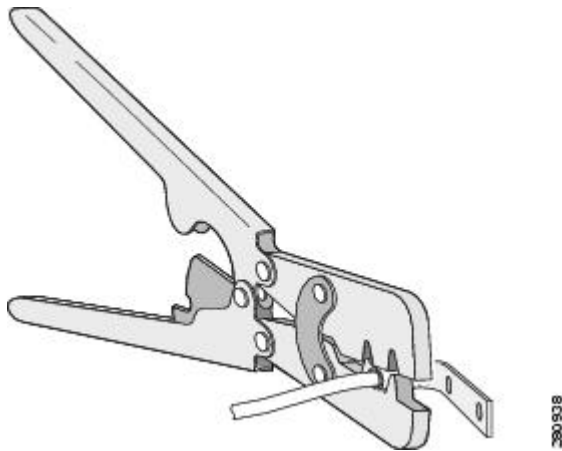

**Step 4** Slide the ground screws from Step 1 through the terminal lug. Insert the ground screws into the opening on the cable side.

## Installing the Power Supply Module in the Router

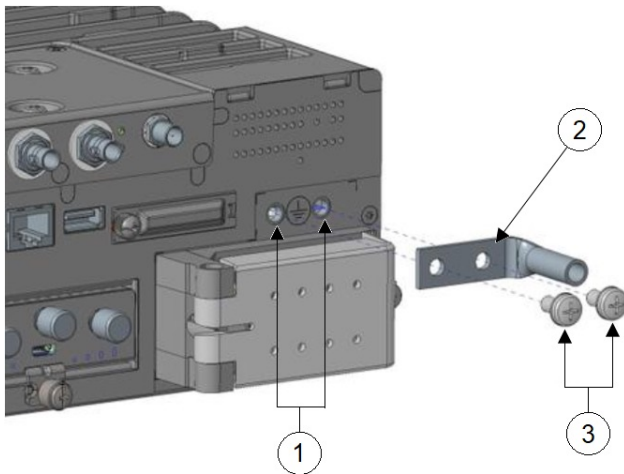

1	Ground lug mounting points	2	Terminal lug
3	M4 screws (2)		

**Step 5** Use a ratcheting torque screwdriver to tighten the ground screws to 11 to 14 in-lbs.

**Step 6** Attach the other end of the ground wire to an appropriate ground.

## Installing the Power Supply Module in the Router

**Step 1** Ensure that the power is off at the AC or DC circuits.

Locate the circuit breakers, turn them OFF, and lock out the circuit.

**Warning** If the power is not off at the AC or DC circuit breaker, do not touch the power-input terminal.

**Step 2** Use a Phillips screwdriver to loosen the two captive screws of the blank power-supply module and gently pull it out.

**Step 3** Insert the power supply module into the slot, and gently push it in. Make sure that the alignment tabs of the module fit into the chassis, as shown in the following figure.

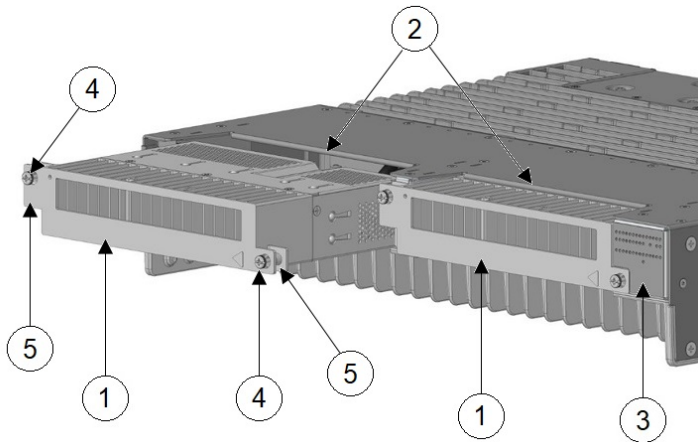

1	Power supply modules	2	Power supply slots
3	LED panel	4	Captive screws
5	Alignment tabs		

- Step 4** After the module is properly inserted, tighten the module plate to the router with the two captive screws. The screws should be torqued to 10 to 12 in-lbs.

## Installing the DC Power Supply in the Router

To remove and install a DC-powered power supply module, follow these steps:

- Step 1** Turn off power at the DC circuits. To ensure that power is removed from the DC circuits, locate the circuit breakers for the DC circuits, switch the circuit breakers to the OFF position, and tape the circuit-breaker switches in the OFF position.
- Step 2** Use a number-2 Phillips screwdriver to remove the plastic safety cover from the power supply terminal blocks.
- Step 3** Use a number-1 Phillips screwdriver to remove the DC-input power wires from the power terminals.  
Use a Phillips screwdriver to loosen the two captive screws at the lower edge that secure the power supply module to the router chassis.
- Step 4** Remove the power supply module from the power slot by pulling on the extraction handle.
- Step 5** Insert the new power supply into the power supply slot, and gently apply pressure while pushing the module into the slot (see the following figure). When correctly inserted, the power supply is flush with the router rear panel.
- Step 6** Use a ratcheting torque screwdriver to torque each screw to 8–10 in-lb (4–6.5 in-lb for 250 W PSU).

## Wiring the Power Source

Before you wire the power source, review these warnings:



**Warning** This product relies on the building's installation for short-circuit (overcurrent) protection. Ensure that the protective device is rated not greater than: AC: 10 A, DC: 15 A Statement 1005



**Warning** A readily accessible two-poled disconnect device must be incorporated in the fixed wiring. Statement 1022



**Warning** Only trained and qualified personnel should be allowed to install or replace this equipment. Statement 1030



**Warning** Hazardous voltage or energy may be present on power terminals. Always replace cover when terminals are not in service. Be sure uninsulated conductors are not accessible when cover is in place. Statement 1086

### Step 1

Ensure that the power is off at the AC or DC circuits.

Locate the circuit breakers, turn them OFF, and lock out the circuit.

**Warning** If the power is not off at the AC or DC circuit breaker, do not touch the power-input terminal.

### Step 2

Use a Phillips screwdriver to loosen the captive screw on the power-input terminal, and open the cover.

*Figure 5: Opening the Power-Input Terminal Cover*



The terminal screws labels are on the power-input terminal cover. See the following figure.



Figure 6: Power-Input Terminal

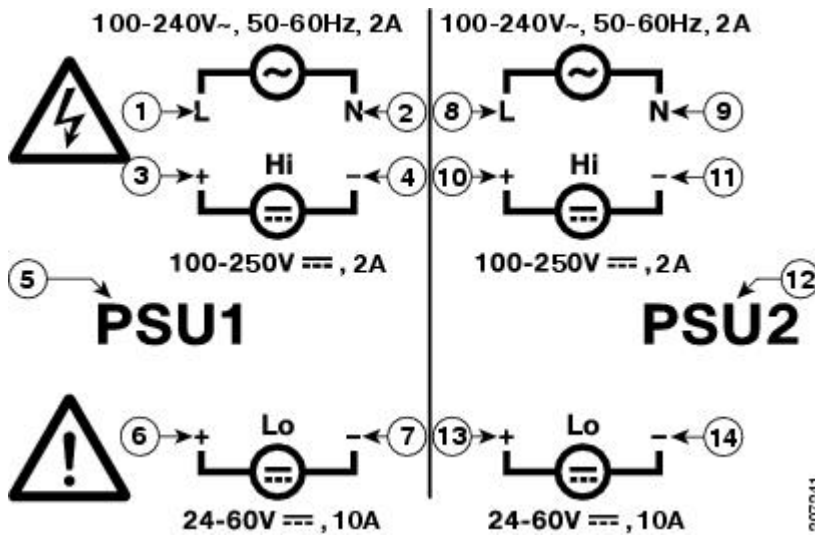

1	Line connection for high-voltage AC (PSU1)	8	Line connection for high-voltage AC (for PSU2)
2	Neutral connection for high-voltage AC (PSU1)	9	Neutral connection for high-voltage AC (PSU2)
3	Positive connection for high-voltage DC (PSU1)	10	Positive connection for high-voltage DC (PSU2)
4	Negative connection for high-voltage DC (PSU1)	11	Negative connection for high-voltage DC (PSU2)
5	PSU1 (power-supply module 1)	12	PSU2 (power-supply module 2)
6	Positive connection for low-voltage DC (PSU1)	13	Positive connection for low-voltage DC (PSU2)
7	Negative connection for low-voltage DC (PSU1)	14	Negative connection for low-voltage DC (PSU2)

**Note** The power-supply module 1 connection is labeled PSU1, and the power-supply module 2 connection is labeled PSU2. Make sure that you connect the wires to the correct terminal screws.

**Step 3** Use twisted-pair copper wire to connect from the power-input terminal to the power source.

**Step 4** Strip each of the two wires to 0.25 inch (6.3 mm) ± 0.02 inch (0.5 mm).

**Note** Do not strip more than 0.27 inch (6.8 mm) of insulation from the wire. Stripping more than the recommended amount of wire can leave exposed wire from the connector after installation.

Figure 7: Stripping the Input Power Source Wire

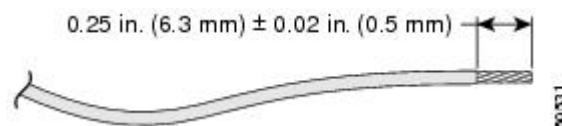

**Step 5** Insert the wire into a spade terminal, and crimp it to the wire.

You can also use a ring or flanged spade terminal as listed in [Equipment That You Need](#), on page 4.

**Figure 8: Crimping the Spade Terminal Lug**

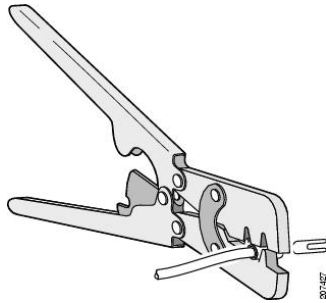

**Step 6** Loosen the terminal screw, and slide the terminal under the screw and washer. See [Figure 10: Connecting the Wires to the Low-Voltage DC Power \(PSU2\)](#), on page 11.

**Note** Use the appropriate terminal screws based on power supply type: high-voltage (AC or DC) or low-voltage (DC).

**Step 7** Make the power connection:

#### AC Power Connection

- Connect the line wire into the terminal screw labeled *L* and the neutral wire into the terminal screw labeled *N* to complete the AC connection.

**Figure 9: Connecting the Wires to the High-Voltage AC Power (PSU1)**

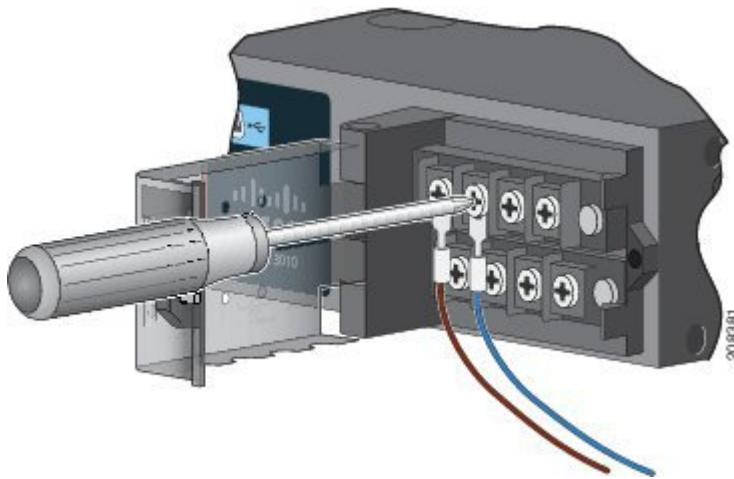

#### DC Power Connection

- Connect the positive wire into the terminal screw labeled “+”, and the negative wire into the terminal screw labeled “-”.

#### Low-voltage DC Power-Supply Module

- Connect the wires to the terminals labeled *Lo*.

#### High-voltage DC Power-Supply Module

- Connect the wires to the terminals labeled *Hi*.

**Note** Ensure that you cannot see any wire lead. Only wire *with insulation* should extend from the terminal screw.

**Figure 10: Connecting the Wires to the Low-Voltage DC Power (PSU2)**

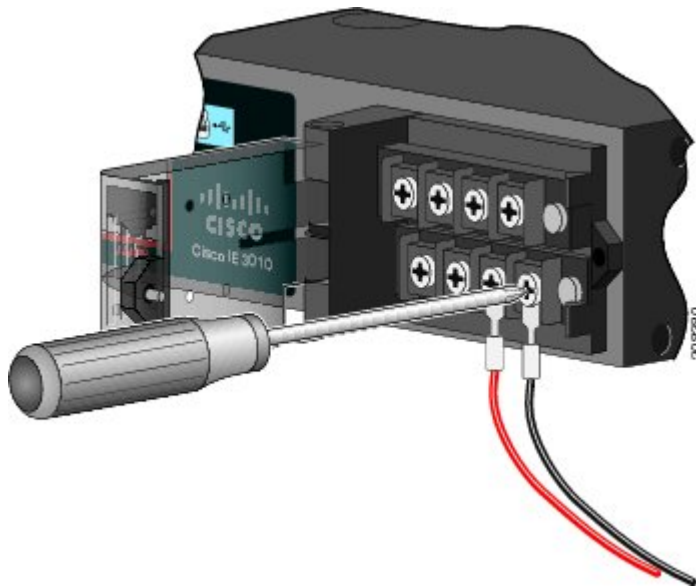

**Step 8** Torque the captive screws (above the wires) to 8.5 in-lb ( $\pm 0.5$  in-lb).

**Step 9** Complete the power connection:

#### AC Power Connection

- Connect the other end of the line wire (the one connected to *L*) to the line terminal on the AC-power source, and connect the other end of the neutral wire (the one connected to *N*) to the neutral terminal on the AC power source.

#### DC Power Connection

- Connect the other end of the positive wire (the one connected to “+”) to the positive terminal on the DC-power source, and connect the other end of the negative wire (the one connected to “-”) to the negative terminal on the DC power source.

**Note** Ensure that you cannot see any wire lead. Only wire *with insulation* should extend from the terminal screw.

If you have two power supplies, repeat steps 1 through 10.

**Step 10** Close the power-input terminal cover.

**Step 11** Use a ratcheting torque screwdriver to torque the screw to 7 in-lb ( $\pm 1$  in-lb).

**Step 12** Turn on the power at the AC or DC circuit.

**Step 13** Verify that the *PSU1* or *PSU2 LED* on the router and *PSU OK* LED on the power-supply module are green.

See the router software guide for information on how to configure the power supply settings.

## Removing the Power Supply Module

The power-supply modules are hot-swappable. By removing the power supply modules, you can power off the router without disconnecting the wiring from the power-input terminal.

---

**Step 1** Ensure that the power is off at the AC or DC circuits.

Locate the circuit breakers, turn them OFF, and lock out the circuit.

**Warning** If the power is not off at the AC or DC circuit breaker, do not touch the power-input terminal.

**Step 2** Verify that the PSU LED and PSU OK LED is blinking red or is off.

**Step 3** Use a Phillips screwdriver to loosen the captive screws that secure the power-supply module to the router.

**Warning** Hot surface. Statement 1079

**Step 4** Remove the power-supply module from the power slot. The power-supply module might be hot. See the following figure.

**Step 5** Install a new power-supply module or a blank cover.

**Caution** To prevent exposure to hazardous voltages and to contain electromagnetic interference (EMI), either a power-supply module or a blank cover must be in each power-supply module slot at all times.

---