



## Configuring IEEE 802.1ad

Provider networks handle traffic from a large number of customers. It is important that one customer's traffic is isolated from the other customer's traffic.

IEEE 802.1ad enables the service providers to use the architecture and protocols of IEEE 802.1Q to offer separate LANs, bridged local area networks, or virtual bridged local area networks to a number of customers, with minimal cooperation or no cooperation between each customer and the service provider.

IEEE 802.1ad implements standard protocols for double tagging of data. The data traffic coming from the customer side are double tagged in the provider network where the inner tag is the customer-tag (C-tag) and the outer tag is the provider-tag (S-tag). The control packets are tunneled by changing the destination MAC address in the provider network.

A service provider's Layer 2 network transports the subscriber's Layer 2 protocols transparently. Provider Bridge allows the service provider switches to transparently carry customer Layer 2 control frames, such as spanning tree Bridge Protocol Data Units (BPDUs) or Cisco proprietary protocol frames such as Cisco Discovery Protocol (CDP) without mixing the service provider's own traffic and with other customer traffic in the service provider's network. A provider bridge is just like a standard 802.1Q bridge, but it imposes a set of requirements, defined by IEEE 802.1ad standards, on a port in a provider bridge which interfaces to customer. This port is a UNI Port. 802.1ad Provider Bridge thus achieves the same functionality as being addressed with L2PT and QinQ.

When Connectivity Fault Management (CFM) is configured on 802.1ad interfaces, all CFM, Link Ethernet Operations, Administration, and Maintenance (OAM), Enhanced Local Management Interface (ELMI) or Y.1731 performance monitoring packets have their own peer or data rules depending on the type of 802.1ad port configured.

- [Finding Feature Information, on page 1](#)
- [Prerequisites for 802.1ad, on page 2](#)
- [Restrictions for 802.1ad, on page 2](#)
- [Information About 802.1ad, on page 3](#)
- [How to Configure 802.1ad, on page 8](#)
- [Verifying IEEE 802.1ad, on page 15](#)
- [Additional References, on page 16](#)

## Finding Feature Information

Your software release may not support all the features documented in this module. For the latest caveats and feature information, see [Bug Search Tool](#) and the release notes for your platform and software release. To

find information about the features documented in this module, and to see a list of the releases in which each feature is supported, see the feature information table.

Use Cisco Feature Navigator to find information about platform support and Cisco software image support. To access Cisco Feature Navigator, go to [www.cisco.com/go/cfn](http://www.cisco.com/go/cfn). An account on Cisco.com is not required.

## Prerequisites for 802.1ad

- Ethertype should be configured.

## Restrictions for 802.1ad

- 802.1ad is supported only on EFP and Trunk EFPs (TEFP).
- SVI based cross-connect, EFP local connect is *not* supported.
- Termination of Layer3 interfaces is *not* supported.
- QoS support is same as supported on the 802.1q EVCs.
- QoS support for classification, marking, weighted tail-drop is not supported on 802.1ad EVCs.
- Routing over BDI with 802.1ad EVC is *not* supported.
- Outer tag Ethertype 0X88a8 is only supported.
- Global **dot1ad** command is not supported.
- Ethernet 802.1ad is *not* supported on port-channels.
- VPLS is not supported for 802.1ad.
- VLAN Translate is not supported for 802.1ad.
- **l2protocol peer** and **l2protocol drop** commands are *not* supported.
- CFI is *not* retained for rewrite push operation.
- Inconsistent VLAN tagging behavior may be seen with rewrite push is configured for S-UNI port and rewrite pop is configured for NNI port
- Translation of UNI-C to NNI port is *not* supported for EVC configuration.
- CFM and Y.1731 are not supported on Smart SFP (SSFP) enabled interfaces for both xconnect and BD.
- NNI port does not drop packets with dot1q outer tag.
- **Encapsulation dot1ad <dot1q>** on NNI ports with rewrite configured as `rewrite ingress tag pop 2 symm` at egress results in pushing 2 dot1q tags. It is advised not to use **pop 2**.

## Rewrite Configuration Model for 802.1ad Ports



**Note** This section is not applicable for RSP3 Module

The table describes the rewrite configuration supported on service instances for the C-UNI, S-UNI and NNI ports

Port	Rewrite	Ingress Direction	Egress Direction
<b>Bridge Domain</b>			
C-UNI	Push	Supported	Not supported
S-UNI			
NNI	Pop	Supported	Not supported
	Push	Not supported	Supported
<b>Trunk EFP</b>			
C-UNI	Pop	Supported	Supported
S-UNI	NA	NA	NA
NNI	Pop	Supported	Not supported
	Push	Not supported	Supported
<b>Cross Connect</b>			
C-UNI	Push	Supported	Not supported
S-UNI			
NNI	NA	NA	NA

## Information About 802.1ad

### 802.1ad Ports

In 802.1ad, a port is configured as either a customer user-network interface (C-UNI), a service-provider UNI (S-UNI), or a network-to-network interface (NNI). Only Layer 2 interfaces can be 802.1ad ports.

- **C-UNI**—an be either an access port or an 802.1Q trunk port. The port uses the customer bridge addresses. To configure a C-UNI port, enter the ethernet dot1ad uni c-port interface configuration command.
- **S-UNI**—an access port that provides the same service to all customer VLANs entering the interface, marking all C-VLANs entering the port with the same S-VLAN. In this mode, the customer's port is

configured as a trunk port, and traffic entering the S-UNI is tagged. Use the ethernet dot1ad uni s-port interface configuration command on an access port with an access VLAN.

- **NNI**—entering the ethernet dot1ad nni interface command on a trunk port creates 802.1ad EtherType (0x88a8) and uses S-bridge addresses for CPU-generated Layer 2 protocol PDUs.

## Service Provider Bridges

Provider bridges pass the network traffic of multiple customers. The traffic flow of each customer must be isolated from one another. For Layer 2 protocols within customer domains to function properly, geographically separated customer sites must appear to be connected via a LAN and the provider network must be transparent.

The IEEE has reserved 33 Layer 2 MAC addresses for customer devices that operate Layer 2 protocols. If a provider bridge uses these standard MAC addresses for its Layer 2 protocols, the Layer 2 traffic of the customer devices and the service provider is mixed together. Provider bridges solve this traffic-mixing issue by providing Layer 2 protocol data unit (PDU) tunneling when a provider bridge (S-bridge) component and a provider edge bridge (C-bridge) component are used. The figure below shows the topology.

**Figure 1: Layer 2 PDU Tunneling**

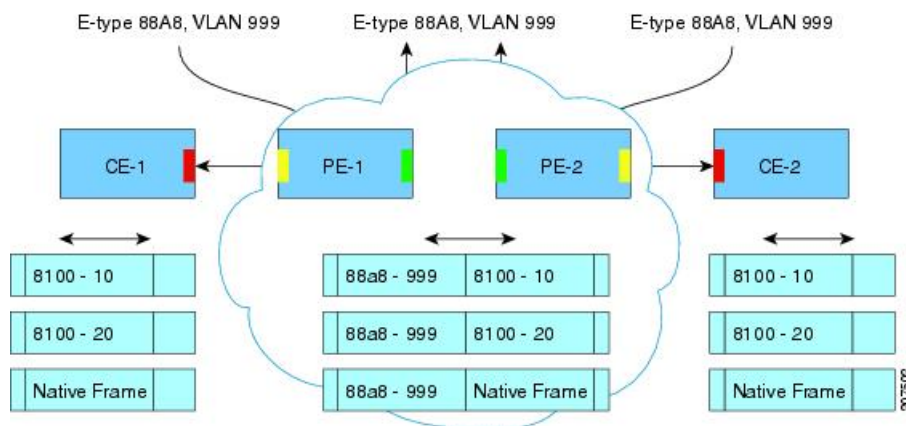

## S-Bridge Component

The S-bridge component is capable of inserting or removing a service provider VLAN (S-VLAN) for all traffic on a particular port. IEEE 802.1ad adds a new tag called a Service tag (S-tag) to all ingress frames traveling from the customer to the service provider.

The VLAN in the S-tag is used for forwarding the traffic in the service provider network. Different customers use different S-VLANs, which results in isolation of traffic of each customer. In the S-tag, provider bridges do not understand the standard Ethertype. Hence, they use an Ethertype value that is different from the standard 802.1Q Ethertype value. This difference makes customer traffic that is tagged with the standard Ethertype appear as untagged in the provider network. The customer traffic is tunneled in the port VLAN of the provider port. 802.1ad service provider user network interfaces (S-UNIs) and network-network interfaces (NNIs) implement the S-bridge component.

For example, a VLAN tag has a VLAN ID of 1, the C-tag Ethertype has a value of 8100 0001, the S-tag Ethertype has a value of 88A8 0001, and the class of service (CoS) has a value of zero.

C-tag S-tag

-----

0x8100 | Priority bits | CFI | C-VLAN-ID 0x88A8 | Priority bits | 0 | S-VLAN-ID

-----

## C-Bridge Component

All customer VLANs (C-VLANs) that enter a user network interface (UNI) port in an S-bridge component receive the same service (marked with the same S-VLAN). C-VLAN components are not supported, but a customer may want to tag a particular C-VLAN packet separately to differentiate between services. Provider bridges allow C-VLAN packet tagging with a provider edge bridge, called the C-bridge component of the provider bridge. C-bridge components are C-VLAN aware and can insert or remove a C-VLAN 802.1Q tag. The C-bridge UNI port is capable of identifying the customer 802.1Q tag and inserting or removing an S-tag on the packet on a per-service instance or C-VLAN basis. A C-VLAN tagged service instance allows service instance selection and identification by C-VLAN. The 801.1ad customer user network interfaces (C-UNIs) implement the C-component.

## NNI Port

Dot1ad NNI port are core facing ports. On this port dot1ad (0x88A8) ethertype is used. The customer facing S-bridge port is identified by using the ethernet dot1ad nni command. The frames forwarded on this port are double tagged with the S-Tag ethertype set at 0x88a8.

## MAC Addresses for Layer 2 Protocols

Layer 2 protocol data units (PDUs) of customers that are received by a provider bridge are not forwarded. Hence, Layer 2 protocols running at customer sites do not know the complete network topology. By using different set of addresses for the Layer 2 protocols running on provider bridges, IEEE 802.1ad causes Layer 2 PDUs of the customers device that enter the provider bridge to appear as unknown multicast traffic and forwards it on customer ports (on the same service provider VLAN (S-VLAN)). Layer 2 protocols of customer device can then run transparently.

The table below shows Layer 2 MAC addresses that are reserved for the C-VLAN component.

**Table 1: Reserved Layer 2 MAC Addresses for the C-VLAN Component**

Assignment	Value
Bridge Group Address	01-80-C2-00-00-00
IEEE 802.3 Full Duplex PAUSE Operation	01-80-C2-00-00-01
IEEE 802.3 Slow_Protocols_Multicast_Address	01-80-C2-00-00-02
IEEE 802.1X PAE Address	01-80-C2-00-00-03
Provider Bridge Group Address	01-80-C2-00-00-08
Provider Bridge GVRP Address	01-80-C2-00-00-0D
IEEE 802.1AB Link Layer Discovery Protocol Multicast Address	01-80-C2-00-00-0E

Assignment	Value
Reserved for future standardization	01-80-C2-00-00-04
	01-80-C2-00-00-05
	01-80-C2-00-00-06
	01-80-C2-00-00-07
	01-80-C2-00-00-09
	01-80-C2-00-00-0A
	01-80-C2-00-00-0B
	01-80-C2-00-00-0C
	01-80-C2-00-00-0F

The table below shows Layer 2 MAC addresses that are reserved for the S-VLAN component. These addresses are a subset of the C-VLAN component addresses, and the C-bridge does not forward the bridge protocol data units (BPDUs) of a provider to a customer network.

**Table 2: Reserved Layer 2 MAC Addresses for the S-VLAN Component**

Assignment	Value
IEEE 802.3 Full Duplex PAUSE Operation	01-80-C2-00-00-01
IEEE 802.3 Slow_Protocols_Multicast_Address	01-80-C2-00-00-02
IEEE 802.1X PAE Address	01-80-C2-00-00-03
Provider Bridge Group Address	01-80-C2-00-00-08
Reserved for future standardization	01-80-C2-00-00-04
	01-80-C2-00-00-05
	01-80-C2-00-00-06
	01-80-C2-00-00-07
	01-80-C2-00-00-09
	01-80-C2-00-00-0A

## Bridge Protocol Data Units Destination MAC Addresses

The table summarizes the actions when a packet is received with destination MAC address for C-UNI, S-UNI and NNI interfaces.

**Table 3: Destination MAC Addresses C-UNI, S-UNI and NNI Ports**

MAC Address	Protocol	C-UNI Action	S-UNI Action	NNI Action
01-80-C2-00-00-00	Bridge Protocol Data Units (BPDUs)	Peer	Data	Data

MAC Address	Protocol	C-UNI Action	S-UNI Action	NNI Action
01-80-C2-00-00-01	802.3X Pause Protocol	Drop	Drop	Drop
01-80-C2-00-00-02	Slow protocol address: 802.3ad LACP, 802.3ah OAM	Peer	Peer	Peer
01-80-C2-00-00-03	802.1x	Not supported	Not supported	Not supported
01-80-C2-00-00-04	Reserved for future media access method	Drop	Drop	Drop
01-80-C2-00-00-05	Reserved for future media access method	Drop	Drop	Drop
01-80-C2-00-00-06	Reserved for future bridge use	Drop	Drop	Drop
01-80-C2-00-00-07	Reserved for future bridge use	Drop	Drop	Drop
01-80-C2-00-00-08	Provider STP (BPDU)	Drop	Drop	Peer
01-80-C2-00-00-09	Reserved for future bridge use	Drop	Drop	Drop
01-80-C2-00-00-0A	Reserved for future bridge use	Drop	Drop	Drop
01-80-C2-00-00-0B	Reserved for future S-bridge use	Drop	Drop	Drop
01-80-C2-00-00-0C	Reserved for future S-bridge purposes	Drop	Drop	Drop
01-80-C2-00-00-0D	Provider bridge Generic VLAN Registration Protocol (GVRP) address	Drop	Drop	Drop
01-80-C2-00-00-0E	802.1ab Link Layer Discovery Protocol (LLDP)	may Peer	Data	Data
01-80-C2-00-00-0F	Reserved for future C- bridge or Q-bridge use	Drop	Drop	Drop

MAC Address	Protocol	C-UNI Action	S-UNI Action	NNI Action
01-80-C2-00-00-10	All bridge domains	Not supported	Not supported	Not supported
01-80-C2-00-00-20	GARP Multicast Registration Protocol (GMRP)	Data	Data	Data
01-80-C2-00-00-21	Generic VLAN Registration Protocol (GVRP)	Data	Data	Data
01-80-C2-00-00-22-2F	Other GARP addresses	Data	Data	Data
01-00-0C-CC-CC-CC	Port Aggregation Protocol (PagP), UniDirectional Link Detection (UDLD),	Peer	Peer	Peer
	Cisco Discovery Protocol (CDP), VLAN Trunk Protocol (VTP)	Peer	Data	Data
	Dynamic Trunking Protocol (DTP)	NA	NA	NA
01-00-0C-CC-CC-CD	Per-VLAN Spanning Tree (PVST)	Peer	Data	Data

## How to Configure 802.1ad

### Configuring the IEEE 802.1ad on Service Instances



#### Note

- The **rewrite pop** command is *not* supported on C-UNI ports.
- Only **encapsulation default** command is supported on S-UNI ports

#### SUMMARY STEPS

1. **enable**
2. **configure terminal**
3. **interface** *interface-id*
4. **ethernet dot1ad** {nni | uni} {c-port | s-port}
5. **service instance** *number* ethernet [*name*]



6. **encapsulation** {**default** | **dot1q** | **priority-tagged** | **untagged**}
7. **bridge-domain** *bridge-id* [**split-horizon group** *group-id*]
8. **rewrite ingress tag** { **pop** {1 | 2} **symmetric** | **push dot1ad** *vlan-id* [**dot1q** *vlan-id*] **symmetric**}
9. **end**

## DETAILED STEPS

	Command or Action	Purpose
Step 1	<b>enable</b> <b>Example:</b> Router> <b>enable</b>	Enables privileged EXEC mode. <ul style="list-style-type: none"> <li>• Enter your password if prompted.</li> </ul>
Step 2	<b>configure terminal</b> <b>Example:</b> Router# <b>configure terminal</b>	Enter global configuration mode.
Step 3	<b>interface</b> <i>interface-id</i> <b>Example:</b> Router(config)# <b>interface</b> <b>gigabitethernet0/0/1</b>	Enter interface configuration mode. Valid interfaces are physical ports.
Step 4	<b>ethernet dot1ad</b> { <b>nni</b>   <b>uni</b> { <b>c-port</b>   <b>s-port</b> }} <b>Example:</b> Router(config-if)# <b>ethernet dot1ad nni</b> or Router(config-if)# <b>ethernet dot1ad uni c-port</b> or Router(config-if)# <b>ethernet dot1ad uni s-port</b>	Configures dot1ad NNI, C-port or S-port on the interface.
Step 5	<b>service instance</b> <i>number</i> <b>ethernet</b> [ <i>name</i> ] <b>Example:</b> Router(config-if)# <b>service instance 1 Ethernet</b>	Configure an EFP (service instance) and enter service instance configuration mode. <ul style="list-style-type: none"> <li>• The number is the EFP identifier, an integer from 1 to 4000.</li> <li>• (Optional) <b>ethernet</b> name is the name of a previously configured EVC. You do not need to use an EVC name in a service instance.</li> </ul>
Step 6	<b>encapsulation</b> { <b>default</b>   <b>dot1q</b>   <b>priority-tagged</b>   <b>untagged</b> } <b>Example:</b> Router(config-if-srv)# <b>encapsulation dot1q 10</b>	Configure encapsulation type for the service instance. <ul style="list-style-type: none"> <li>• <b>default</b>—Configure to match all unmatched packets.</li> <li>• <b>dot1q</b>—Configure 802.1Q encapsulation. See <a href="#">Table 1</a> for details about options for this keyword.</li> <li>• <b>priority-tagged</b>—Specify priority-tagged frames, VLAN-ID 0 and CoS value of 0 to 7.</li> <li>• <b>untagged</b>—Map to untagged VLANs. Only one EFP per port can have untagged encapsulation.</li> </ul>

	Command or Action	Purpose
<b>Step 7</b>	<b>bridge-domain</b> <i>bridge-id</i> [ <b>split-horizon group</b> <i>group-id</i> ] <b>Example:</b> Router(config-if-srv)# <b>bridge-domain</b> 3000	Configure the bridge domain ID. The range is from 1 to 4000.  You can use the <b>split-horizon</b> keyword to configure the port as a member of a split horizon group. The <i>group-id</i> range is from 0 to 2.
<b>Step 8</b>	<b>rewrite ingress tag</b> { <b>pop</b> {1   2} <b>symmetric</b>   <b>push dot1ad</b> <i>vlan-id</i> [ <b>dot1q</b> <i>vlan-id</i> ] <b>symmetric</b> } <b>Example:</b> Router(config-if-srv)# <b>rewrite ingress tag pop 1 symmetric</b> Router(config-if-srv)# <b>rewrite ingress tag push dot1ad 30 symmetric</b>	(Optional) Specify that encapsulation modification to occur on packets at ingress. <ul style="list-style-type: none"> <li>• <b>pop 1</b>—Pop (remove) the outermost tag.</li> <li>• <b>pop 2</b>—Pop (remove) the two outermost tags.</li> <li>• <b>symmetric</b>—Configure the packet to undergo the reverse of the ingress action at egress. If a tag is popped at ingress, it is pushed (added) at egress. This keyword is required for <b>rewrite</b> to function properly.</li> <li>• <b>push</b>—Adds a tag to an ingress packet.</li> <li>• <b>dot1ad</b> <i>vlan-id</i>—Specifies the 802.1 dot1ad tag. Valid Vlan ID range is from 1 to 4094.</li> <li>• <b>dot1q</b> <i>vlan-id</i>—Specifies the 802.1 dot1q tag. Valid Vlan ID range is from 1 to 4094.</li> </ul>
<b>Step 9</b>	<b>end</b> <b>Example:</b> Router(config-if-srv)# <b>end</b>	Return to privileged EXEC mode.

### Configuration Examples

The example shows the C-UNI port.

```
interface GigabitEthernet0/3/7
 ethernet dot1ad uni c-port
 service instance 20 ethernet
 encapsulation dot1q 20
 rewrite ingress tag push dot1ad 30 symmetric
 bridge-domain 20
```

The example shows the S-UNI port.

```
interface GigabitEthernet0/3/7
 ethernet dot1ad uni s-port
 service instance 20 ethernet
 encapsulation default
 rewrite ingress tag push dot1ad 30 symmetric
 bridge-domain 20
```

The example shows the NNI port.

```
interface GigabitEthernet0/5/2
 ethernet dot1ad nni
 service instance 20 ethernet
```

```
encapsulation dot1ad 30
bridge-domain 20
```

## Configuring the IEEE 802.1ad on Trunk EFP Service Instances



- Note**
- The **rewrite pop** command is *not* supported on C-UNI ports.
  - Trunk EFP is *not* supported on S-UNI ports

### SUMMARY STEPS

1. **enable**
2. **configure terminal**
3. **interface** *interface-id*
4. **ethernet dot1ad** {nni | uni {c-port}}
5. **service instance** [trunk] *number* ethernet
6. **encapsulation dot1q**
7. **bridge-domin** *bridge-id* from-encapsulation
8. **rewrite ingress tag** { pop {1 | 2} symmetric
9. **end**

### DETAILED STEPS

	Command or Action	Purpose
<b>Step 1</b>	<b>enable</b> <b>Example:</b> Router> <b>enable</b>	Enables privileged EXEC mode. <ul style="list-style-type: none"> <li>• Enter your password if prompted.</li> </ul>
<b>Step 2</b>	<b>configure terminal</b> <b>Example:</b> Router# <b>configure terminal</b>	Enter global configuration mode.
<b>Step 3</b>	<b>interface</b> <i>interface-id</i> <b>Example:</b> Router(config)# <b>interface</b> gigabitethernet0/0/1	Enter interface configuration mode. Valid interfaces are physical ports.
<b>Step 4</b>	<b>ethernet dot1ad</b> {nni   uni {c-port}} <b>Example:</b> Router(config-if)# <b>ethernet dot1ad</b> nni or Router(config-if)# <b>ethernet dot1ad</b> uni c-port	Configures Trunk EFP on dot1ad NNI and C-UNI ports on the interface. <b>Note</b> Trunk EFP is <i>not</i> supported on the S-UNI port.

	Command or Action	Purpose
<b>Step 5</b>	<b>service instance [trunk] number ethernet</b> <b>Example:</b> <pre>Router(config-if)# service instance trunk 1 ethernet</pre>	Configure an EFP (service instance) and enter service instance configuration) mode <ul style="list-style-type: none"> <li>• The number is the EFP identifier, an integer from 1 to 4000</li> <li>• The trunk keyword identifies the trunk ID to which the service instance is assigned.</li> </ul> <p><b>Note</b> Trunk EFP (without port channel) supports encapsulation of up to 1000 Vlans.</p>
<b>Step 6</b>	<b>encapsulation dot1q</b> <b>Example:</b> <pre>Router(config-if-srv)# encapsulation dot1q 10</pre>	Configure encapsulation type for the service instance. <ul style="list-style-type: none"> <li>• <b>dot1q</b>—Configure 802.1Q encapsulation.</li> </ul>
<b>Step 7</b>	<b>bridge-domain bridge-id from-encapsulation</b> <b>Example:</b> <pre>Router(config-if-srv)# bridge-domain from-encapsulation</pre>	Configures the router to derive bridge domains from the encapsulation VLAN list.
<b>Step 8</b>	<b>rewrite ingress tag { pop {1   2} symmetric</b> <b>Example:</b> <pre>Router(config-if-srv)# rewrite ingress tag pop 1 symmetric</pre>	(Optional) Specify that encapsulation modification to occur on packets at ingress. <ul style="list-style-type: none"> <li>• <b>pop 1</b>—Pop (remove) the outermost tag.</li> <li>• <b>pop 2</b>—Pop (remove) the two outermost tags.</li> <li>• <b>symmetric</b>—Configure the packet to undergo the reverse of the ingress action at egress. If a tag is popped at ingress, it is pushed (added) at egress. This keyword is required for <b>rewrite</b> to function properly.</li> </ul>
<b>Step 9</b>	<b>end</b> <b>Example:</b> <pre>Router(config-if-srv)# end</pre>	Return to privileged EXEC mode.

### Configuration Examples

The example shows the Trunk EFP configuration on the C-UNI port.

```
interface GigabitEthernet0/3/7
 ethernet dot1ad uni c-port
 service instance trunk 20 ethernet
 encapsulation dot1q 20-30
 rewrite ingress tag pop1 symmetric
 bridge-domain from-encapsulation
```

The example shows the Trunk EFP configuration on the NNI port.

```
interface GigabitEthernet0/5/2
 ethernet dot1ad nni
```

```

service instance trunk 20 ethernet
encapsulation dot1ad 20-30
rewrite ingress tag popl symmetric
bridge-domain from-encapsulation

```

## Configuring the IEEE 802.1ad on Cross-Connect on EFP



### Note

- The **rewrite push** command is supported on C-UNI and S-UNI ports. Rewrite is *not* supported for NNI ports.
- Only **encapsulation default** command is supported on S-UNI ports

### SUMMARY STEPS

1. **enable**
2. **configure terminal**
3. **interface** *interface-id*
4. **ethernet dot1ad** {nni | uni {c-port | s-port}}
5. **service instance** *number* ethernet [*name*]
6. **encapsulation** {default | dot1q | priority-tagged | untagged}
7. **rewrite ingress tag push dot1ad** *vlan-id* [dot1q *vlan-id*] symmetric}
8. **xconnect** *peer-router-id* *vcid* **pw-class** *pw-class name*
9. **end**

### DETAILED STEPS

	Command or Action	Purpose
Step 1	<b>enable</b>  <b>Example:</b> Router> <b>enable</b>	Enables privileged EXEC mode.  • Enter your password if prompted.
Step 2	<b>configure terminal</b>  <b>Example:</b> Router# <b>configure terminal</b>	Enter global configuration mode.
Step 3	<b>interface</b> <i>interface-id</i>  <b>Example:</b> Router(config)# <b>interface</b> <b>gigabitethernet0/0/1</b>	Enter interface configuration mode. Valid interfaces are physical ports.
Step 4	<b>ethernet dot1ad</b> {nni   uni {c-port   s-port}}  <b>Example:</b>  Router(config-if)# <b>ethernet dot1ad</b> <b>nni</b> or Router(config-if)# <b>ethernet dot1ad</b> <b>uni</b> <b>c-port</b>	Configures dot1ad NNI, C-port or S-port on the interface.

	Command or Action	Purpose
	or Router(config-if)# <b>ethernet dot1ad uni s-port</b>	
<b>Step 5</b>	<b>service instance</b> <i>number</i> <b>ethernet</b> [ <i>name</i> ] <b>Example:</b> Router(config-if)# <b>service instance 1 Ethernet</b>	Configure an EFP (service instance) and enter service instance configuration) mode. <ul style="list-style-type: none"> <li>• The number is the EFP identifier, an integer from 1 to 4000.</li> <li>• (Optional) <b>ethernet</b> name is the name of a previously configured EVC. You do not need to use an EVC name in a service instance.</li> </ul>
<b>Step 6</b>	<b>encapsulation</b> { <b>default</b>   <b>dot1q</b>   <b>priority-tagged</b>   <b>untagged</b> } <b>Example:</b> Router(config-if-srv)# <b>encapsulation dot1q 10</b>	Configure encapsulation type for the service instance. <ul style="list-style-type: none"> <li>• <b>default</b>—Configure to match all unmatched packets.</li> <li>• <b>dot1q</b>—Configure 802.1Q encapsulation. See <a href="#">Table 1</a> for details about options for this keyword.</li> <li>• <b>priority-tagged</b>—Specify priority-tagged frames, VLAN-ID 0 and CoS value of 0 to 7.</li> <li>• <b>untagged</b>—Map to untagged VLANs. Only one EFP per port can have untagged encapsulation.</li> </ul>
<b>Step 7</b>	<b>rewrite ingress tag push dot1ad</b> <i>vlan-id</i> [ <b>dot1q</b> <i>vlan-id</i> ] <b>symmetric</b> } <b>Example:</b> Router(config-if-srv)# <b>rewrite ingress tag push dot1ad 30 symmetric</b>	(Optional) Specify that encapsulation modification to occur on packets at ingress. <ul style="list-style-type: none"> <li>• <b>symmetric</b>—Configure the packet to undergo the reverse of the ingress action at egress. If a tag is popped at ingress, it is pushed (added) at egress. This keyword is required for <b>rewrite</b> to function properly.</li> <li>• <b>push</b>—Adds a tag to an ingress packet.</li> <li>• <b>dot1ad</b> <i>vlan-id</i>—Specifies the 802.1 do1ad tag. Valid Vlan ID range is from 1 to 4094.</li> <li>• <b>dot1q</b> <i>vlan-id</i>—Specifies the 802.1 do1q tag. Valid Vlan ID range is from 1 to 4094.</li> </ul>
<b>Step 8</b>	<b>xconnect</b> <i>peer-router-id</i> <i>vcid</i> <b>pw-class</b> <i>pw-class name</i> <b>Example:</b> Router(config-if-srv)# <b>xconnect 10.10.10.10 123 encapsulation mpls</b>	Bind the attachment circuit to a pseudowire virtual circuit (VC) and enter cross connect configuration mode.
<b>Step 9</b>	<b>end</b> <b>Example:</b> Router(config-if-srv)# <b>end</b>	Return to privileged EXEC mode.

### Configuration Examples

The example shows the C-UNI port.

```
interface GigabitEthernet0/3/7
 ethernet dot1ad uni c-port
 service instance 20 ethernet
 encapsulation dot1q 20
 rewrite ingress tag push dot1ad 30 symmetric
 xconnect 2.2.2.2 20 encap mpls
```

The example shows the S-UNI port.

```
interface GigabitEthernet0/3/7
 ethernet dot1ad uni s-port
 service instance 20 ethernet
 encapsulation default
 rewrite ingress tag push dot1ad 30 symmetric
 xconnect 2.2.2.2 20 encap mpls
```

The example shows the NNI port.

```
interface GigabitEthernet0/3/7
 ethernet dot1ad nni
 service instance 20 ethernet
 encapsulation dot1ad 20
 xconnect 2.2.2.2 20 encap mpls
```

## Verifying IEEE 802.1ad

Use the **show ethernet dot1ad** commands to verify IEEE 802.1ad configuration.

- **show ethernet dot1ad**

This command displays 802.1ad configuration globally on the router. The following is a sample output from the command:

```
Router# show ethernet dot1ad

Interface: GigabitEthernet0/2/1
DOT1AD NNI Port
L2protocol pass

Interface: GigabitEthernet0/2/7
DOT1AD C-Bridge Port
L2protocol pass
```

- **show ethernet dot1ad [interface interface-name]**

This command displays interface dot1ad configuration. The following is a sample output from the command:

```
Router# show ethernet dot1ad interface gigabitethernet 0/2/1

Interface: GigabitEthernet0/2/1
DOT1AD NNI Port
```

L2protocol pass

## Additional References

### Related Documents

Related Topic	Document Title
Cisco IOS master command list	<a href="#">Cisco IOS Master Command List</a> , All Releases

### Standards

Standard	Title
No new or modified standards are supported, and support for existing standards has not been modified.	--

### MIBs

MIB	MIBs Link
No new or modified MIBs are supported, and support for existing MIBs has not been modified.	To locate and download MIBs for selected platforms, Cisco IOS releases, and feature sets, use Cisco MIB Locator found at the following URL: <a href="http://www.cisco.com/go/mibs">http://www.cisco.com/go/mibs</a>

### RFCs

RFC	Title
No new or modified RFCs are supported, and support for existing RFCs has not been modified.	--

### Technical Assistance

Description	Link
The Cisco Support and Documentation website provides online resources to download documentation, software, and tools. Use these resources to install and configure the software and to troubleshoot and resolve technical issues with Cisco products and technologies. Access to most tools on the Cisco Support and Documentation website requires a Cisco.com user ID and password.	<a href="http://www.cisco.com/cisco/web/support/index.html">http://www.cisco.com/cisco/web/support/index.html</a>