



Configuring OC-192 Interface Module or 8-port Low Rate CEM Interface Module (10G HO / 10G LO), Cisco IOS XE Everest 3.18SP (Cisco NCS 4200 Series)

First Published: 2016-07-29

Last Modified: 2016-07-29

Americas Headquarters

Cisco Systems, Inc.
170 West Tasman Drive
San Jose, CA 95134-1706
USA
<http://www.cisco.com>
Tel: 408 526-4000
800 553-NETS (6387)
Fax: 408 527-0883



CONTENTS

CHAPTER 1

Configuring CEM 1

Circuit Emulation 1

Restrictions for CEM 1

Structure-Agnostic TDM over Packet 2

Framed Structure-Agnostic TDM over Packet (SAToP) 2

Configuring CEM 4

Pseudowire Scale Support 4

Configuring CEM Group for SAToP for T1 Interfaces 5

Configuring CEM Classes 5

Configuring CEM Parameters 6

Configuring Payload Size (Optional) 6

Setting the Dejitter Buffer Size 6

Shutting Down a CEM Channel 7

Configuring DS1 CT3 SAToP Mode 7

Configuring VT DS1 SAToP Mode 7

Configuring STS-Nc CEP 7

Configuring CEP 8

Configuring VT-15 CEP 8

Configuring DS3 SAToP 8

Configuring CEM APS 8

Configuring Unidirectional APS for SAToP 9

Configuring Bi-directional ACR (SONET Framing) for SAToP 9

Verifying CEM Statistics for SAToP 10

Associated Commands 11

Additional References for Configuring CEM 12

CHAPTER 2	CEM over MPLS QoS	15
	Finding Feature Information	15
	Information About CEM over MPLS QoS	16
	Classifying and Marking MPLS EXP Overview	16
	Prerequisites for CEM over MPLS QoS	16
	Restrictions for CEM over MPLS QoS	16
	How to Classify and Mark MPLS EXP	17
	Classifying MPLS Encapsulated Packets	17
	Marking MPLS EXP on Imposed Labels	17
	Classifying and Marking MPLS EXP	17
	Configuration Examples	18
	Example: Defining an MPLS EXP Class Map	18
	Example: Defining a Policy Map and Applying the Policy Map to an Ingress Interface	18
	Example: Defining a Policy Map and Applying the Policy Map to an Egress Interface	18
	Example: Defining an MPLS EXP Imposition Policy Map	19
	Example: Applying the MPLS EXP Imposition Policy Map to a Main Interface	19
	Example: Applying the MPLS EXP Imposition Policy Map to an EVC	19
	Example: Defining an MPLS EXP Label Switched Packets Policy Map	20
	Example: Applying the MPLS EXP Label Switched Packets Policy Map to a Main Interface	20
	Additional References for CEM over MPLS QoS	20
CHAPTER 3	Configuring SONET	23
	Overview of SONET	24
	Restrictions for SONET	24
	SONET Switching	25
	SONET Hierarchy	26
	Section	26
	Line	26
	Path	26
	STS-1 and STS-3 Frames	27
	SONET Line and Section Configuration Parameters	28
	BERT	29
	BERT Patterns on 1-Port OC-192 or 8-Port Low Rate CEM Interface Module	29

Concatenated SONET Frames	30
SONET Path Level Configuration Parameters	30
Channelized SONET Frames	31
SONET T1 Configuration Parameters	31
SONET T3 Configuration Parameters	31
SONET VT Configuration Parameters	32
Automatic Protection Switching	32
1+1 APS	33
Benefits of APS	33
APS 1+1 for SONET Layer 1 traffic	34
How to Configure SONET	37
Prerequisites for Configuring SONET	37
Configuring MediaType Controller	37
Configuring SONET Ports	37
Managing and Monitoring SONET Line	38
Configuring Line and Section Overhead	38
Configuring Line and Section Threshold	38
Configuring Line Loopback	38
Configuring AIS Shut	39
Configuring Shut	39
Configuring Alarm Reporting	39
Configuring Clock	39
Configuring STS-1 Modes	40
Verification of SONET Configuration	47
Performance Monitoring Use Cases or Deployment Scenarios	51
Configuring Port Rate and Verifying Pluggables	64
Configuring ONS Pluggables	64
Verifying the Pluggables	64
Configuring BERT in Sonet for CESoPSN	66
Configuring VT1.5-T1 BERT for CESoPSN	67
Verifying VT1.5-T1 BERT Configuration for CESoPSN	67
Configuring CT3-T1 mode BERT for CESoPSN	67
Verifying CT3-T1 mode BERT for CESoPSN	68
Loopback Remote on T1 and T3 Interfaces	68

Restrictions for Loopback Remote	68
Configuring Loopback Remote in Sonet	68
Verifying the Loopback Remote Configuration	69
Clock Recovery System in CESoPSN	70
Adaptive Clock Recovery in CESoPSN	70
Differential Clock Recovery in CESoPSN	71
Benefits of Clock Recovery	71
Prerequisites for Clock Recovery	72
Restrictions for Clock Recovery	72
Configuring ACR in VT 1.5-T1 mode for CESoPSN	72
Verifying ACR in VT 1.5-T1 mode for CESoPSN	73
Configuring DCR in VT 1.5-T1 mode for CESoPSN	73
Verifying DCR in VT 1.5-T1 mode for CESoPSN	73
Configuring ACR in CT3-T1 mode for CESoPSN	74
Verifying ACR in CT3-T1 mode for CESoPSN	74
Configuring DCR in CT3-T1 mode for CESoPSN	74
Verifying DCR in CT3-T1 mode for CESoPSN	75
Configuring Clocking for ACR and DCR on APS for CESoPSN	75
Configuring Clocking for ACR on APS CT3-T1 in CESoPSN	75
Verifying Clocking for ACR on APS CT3-T1 in CESoPSN	76
Configuring Clocking for DCR on APS CT3-T1 in CESoPSN	76
Verifying Clocking for DCR on APS CT3-T1 in CESoPSN	77
Configuring Clocking for ACR on APS VT 1.5-T1 in CESoPSN	77
Verifying Clocking for ACR on APS VT 1.5-T1 in CESoPSN	78
Configuring Clocking for DCR on APS VT 1.5-T1 in CESoPSN	78
Verifying Clocking for DCR on APS VT 1.5-T1 in CESoPSN	79
Configuring VT-15 mode of STS-1 for Framed SAToP	79
Configuring DS1/T1 CT3 mode of STS-1 for Framed SAToP	80
Verifying SONET Configuration for Framed SAToP	80
Associated Commands	81
Additional References for Configuring SONET on 1-Port OC192/STM-64 or 8-Port OC3/12/48/STM-1/-4/-16 Interface Module	83

Alarm History Restrictions	85
Configuring Alarm History	86
Verifying Alarm History Configuration	86
Associated Commands	87
Additional References for Alarm History	87

CHAPTER 5

Clock Recovery System for SAToP	89
Finding Feature Information	89
Information About Clock Recovery	89
Adaptive Clock Recovery (ACR)	89
Differential Clock Recovery (DCR)	90
Explicit Pointer Adjustment Relay (EPAR)	90
Restrictions for EPAR	91
Benefits of Clock Recovery	91
Prerequisites for Clock Recovery	91
Restrictions for Clock Recovery	92
How to Configure Adaptive Clock Recovery (ACR)	92
Configuring ACR for OCn	92
Configuring ACR in Mode VT15 for SAToP	92
Configuring ACR in mode T3 for SAToP	93
Configuring ACR in Mode CT3 for SAToP	94
Configuring DCR for OCn	95
Configuring DCR in Mode VT15 for SAToP	95
Configuring DCR in Mode CT3 for SAToP	96
Configuring DCR in Mode T3 for SAToP	97
Verification of EPAR Configuration	98
Recovering a Clock	98
Example: Adaptive Clock Recovery (ACR) for SAToP	99
Example: Differential Clock Recovery (DCR) for SAToP	100
Additional References for Clock Recovery	101



CHAPTER 1

Configuring CEM

This module describes how to configure Circuit Emulation (CEM).

- [Circuit Emulation, on page 1](#)
- [Framed Structure-Agnostic TDM over Packet \(SAToP\), on page 2](#)
- [Configuring CEM, on page 4](#)
- [Verifying CEM Statistics for SAToP, on page 10](#)
- [Associated Commands, on page 11](#)
- [Additional References for Configuring CEM, on page 12](#)

Circuit Emulation

Circuit Emulation (CEM) is a technology that provides a protocol-independent transport over IP/MPLS networks. It enables proprietary or legacy applications to be carried transparently to the destination, similar to a leased line.

CEM provides a bridge between a Time-Division Multiplexing (TDM) network and Multiprotocol Label Switching (MPLS) network. The router encapsulates the TDM data in the MPLS packets and sends the data over a CEM pseudowire to the remote Provider Edge (PE) router. As a result, CEM functions as a physical communication link across the packet network.

The router supports the pseudowire type that utilizes CEM transport: Structure-Agnostic TDM over Packet (SAToP) and Circuit Emulation Service over Packet-Switched Network (CESoPSN).

L2VPN over IP/MPLS is supported on the interface modules.



Note We recommend that you configure the controller in the administratively up mode. Configuration under the administratively down mode is not recommended and it might cause configuration errors.

Restrictions for CEM

The **framed** command is not supported.

Structure-Agnostic TDM over Packet

Structure-Agnostic TDM over Packet (SAToP) encapsulates Time Division Multiplexing (TDM) bit-streams as pseudowires over public switched networks. It disregards any structure that may be imposed on streams, in particular the structure imposed by the standard TDM framing.

The protocol used for emulation of these services does not depend on the method in which attachment circuits are delivered to the Provider Edge (PE) chassis. For example, a T1 attachment circuit is treated the same way for all delivery methods, including copper, multiplex in a T3 circuit, a virtual tributary of a SONET circuit, or unstructured Circuit Emulation Service (CES).

In SAToP mode, the interface is considered as a continuous framed bit stream. The packetization of the stream is done according to IETF RFC 4553. All signaling is carried out transparently as a part of a bit stream.

Framed Structure-Agnostic TDM over Packet (SAToP)

Framed Structure-Agnostic TDM over Packet (SAToP) is required to detect an incoming AIS alarm in the DS1 SAToP mode. An AIS alarm indicates a problem with the line that is upstream from the DS1 network element connected to the interface. Framed SAToP further helps in the detection of a packet drop.

In case of unframed mode of SAToP, data received from the Customer Edge (CE) device is transported over the pseudowire. If the Provider Edge (PE) device receives a Loss of Frame (LOF) signal or Remote Alarm Indication (RAI) signal from a CE, the PE can only transmit the signal that is detected by the CE device. With the introduction of Framed SAToP, when the PE device receives the LOF or RAI signal, the PE device can detect the alarm for SAToP. Thus, the alarm can be detected earlier in the network. This helps in enhanced performance.



Note Framing type should be maintained same in all routers end to end.

Difference between Framed and Unframed SAToP:

1. For unframed SAToP, the incoming signal is transmitted to the far end. This signal is not analyzed by the PE device. Hence, no alarm is reported.
2. For framed SAToP, the incoming signal is analyzed but is not terminated. If a LOF or RAI signal is detected, the remote PE detects the signals and transmits towards the remote CE.

Difference between Framed SAToP and CESoP:

Table 1: Behaviour Difference between Unframed SAToP, Framed SAToP, and CESoP on LOF Alarm

Modes	Alarm Detected at PE	Controller Status at PE	Alarm Detected at CE (Remote)	Framing Bits Generation at PE (Remote)	Framing Bits Terminated at PE (Remote)
Unframed SAToP	None	Up	LOF	No	No
Framed SAToP	LOF	Down (Data path remains up)	AIS ¹²	Yes	No

Modes	Alarm Detected at PE	Controller Status at PE	Alarm Detected at CE (Remote)	Framing Bits Generation at PE (Remote)	Framing Bits Terminated at PE (Remote)
CESOP	LOF	Down (Data path remains up)	AIS	Yes	Yes

¹ AIS—Cisco IOS XE Amsterdam 17.3.1 to later releases

² LOF—Support until Cisco IOS XE Amsterdam 17.2.1

Table 2: Behaviour Difference between Unframed SAToP, Framed SAToP, and CESoP on RDI Alarm

Modes	Alarm Detected at PE	Controller Status at PE	Alarm Detected at CE (Remote)	Framing Bits Generation at PE (Remote)	Framing Bits Terminated at PE (Remote)
Unframed SAToP	None	Up	RDI	No	No
Framed SAToP	RDI	Down (data path remains up)	RDI	No	No
CESOP	RDI	Down (data path remains up)	RDI	M-bit is set into control word	Yes

Table 3: Behaviour Difference between Unframed SAToP, Framed SAToP, and CESoP on AIS alarm

Modes	Alarm Detected at PE	Controller Status at PE	Alarm Detected at CE (Remote)	Framing Bits Generation at PE (Remote)	Framing Bits Terminated at PE (Remote)
Unframed SAToP	AIS	Down (data path remains up)	AIS	No	No
Framed SAToP	AIS	Down (data path remains up)	AIS	No	No
CESOP	AIS	Down (data path remains up)	AIS	L-bit is set into control word	Yes

Remote Loopback from CE to PE Detection:

Framed SAToP does not detect any loopback.

	Loopback Detected at PE	Controller Status at PE (Remote)	Controller Status at CE (Remote)
Unframed SAToP	No	Not in Loopback	Loopback
Framed SAToP	No	Not in Loopback	Loopback
CESOP	Yes	Loopback	Not in loopback

Configuring CEM

This section provides information about how to configure CEM. CEM provides a bridge between a Time Division Multiplexing (TDM) network and a packet network, MPLS. The chassis encapsulates the TDM data in the MPLS packets and sends the data over a CEM pseudowire to the remote Provider Edge (PE) chassis.

The following sections describe how to configure CEM.

Configuring CEM Restriction

- Not all combinations of payload size and dejitter buffer size are supported. If you apply an incompatible payload size or dejitter buffer size configuration, the chassis rejects it and reverts to the previous configuration.
- The dummy-pattern command is *not* supported.



Note CEM interface does *not* support idle-cas parameter.

Pseudowire Scale Support

Table 4: Feature History

Feature Name	Release	Description
Pseudowire Scale Support	Cisco IOS XE Amsterdam 17.3.1	A maximum of 26,880 CEM Pseudowires are supported on the Cisco RSP3 chassis using combination of the 1-Port OC-192 or 8-Port Low Rate CEM interface module.
Pseudowire Scale Support	Cisco IOS XE Gibraltar 16.12.1	A maximum of 21,504 Pseudowires are supported on the Cisco RSP3 chassis using combination of the 1-Port OC-192 or 8-Port Low Rate CEM interface module.

Effective **Cisco IOS XE Amsterdam 17.3.1**, the Cisco router supports,

- 26,880 CEM Pseudowires (PWs) without protection (with SONET)
- 13,440 CEM PWs with protection

Effective Cisco **IOS XE 16.12.1**, the Cisco router supports,

- 21,504 CEM Pseudowire (PWs) without protection (with SONET)
- 10,752 CEM PWs with protection



Note These 26,880 and 21,504 CEM PWs can be achieved on the router by using the combination of the 1-port OC-192 Interface module or 8-port Low Rate Interface Module and 1-port OC148/ STM-16 or 4-port OC-12/OC-3 / STM-1/STM-4 + 12-Port T1/E1 + 4-Port T3/E3 CEM Interface Module IMs with the 48-port T3/E3 CEM Interface Module and 48-port T1/E1 CEM Interface Module (ASR 900 48-port T1/E1 Interface Module) in multiple slot combinations.

Restrictions for PW Scale

- CEM PW scale is supported in **only** in the SONET mode.
- When configured for scale beyond the maximum CEM PW scale, a syslog is generated as *Cannot allocate CEM group*, maximum CEM group exceeded, but the configurations will not be rejected.
- While performing ISSU with the specified CEM PW scales, sufficient interface-module-delay must be provided for each IM. This provision enables all PWs to program after the IM OIR. The minimum ‘time for delay’ in case of 1-port OC-192 Interface module or 8-port Low Rate Interface Module (ASR 900 Combo 8-port SFP GE and 1-port 10GE IM with CEM, 10G) is 1800 seconds.
- After SSO and successful bulk sync, run the **show platform software tdm-combo cem ha-stray-entries** command. If the output of this command displays no entries, then the next SSO can be performed. You must wait until **show platform software tdm-combo cem ha-stray-entries** has no entries.



Note To configure CEM circuits (for example, T1 or VT1.5 CEP pseudowire) at a large number (for example, 10,000), we recommend you to configure the CEM circuits in a batch of 2000 CEM circuits. Use the **show platform software tdm-combo cem ha-stray-entries** command to verify that there are no pending circuits to be programmed before proceeding to the next batch of configuration. The **show platform software tdm-combo cem ha-stray-entries** command can be used only in the standby RSP3 console.

Configuring CEM Group for SAToP for T1 Interfaces

To configure a CEM group for SAToP.

```
enable
configure terminal
controller t1 0/4/0
cem-group 0 unframed
end
```



Note You need metroaggrservice license to configure CEM group on the Interface Module.

Configuring CEM Classes

A CEM class is a single step configuration of CEM parameters such as payload size and dejitter buffer that you can perform at the global configuration mode and apply this CEM class on an individual CEM interfaces.

Thus the CEM class allows you to create a single configuration template for multiple CEM pseudowires.

Follow these steps to configure a CEM class:



-
- Note**
- The CEM parameters can be configured either by using CEM class or on CEM interface directly.
 - The CEM parameters at the local and remote ends of a CEM circuit must match; otherwise, the pseudowire between the local and remote PE chassis does not come up.
-

```
enable
configure terminal
class cem mycemclass
payload-size 512
dejitter-buffer 12
exit
interface cem 0/0/1
cem 0
cem class mycemclass
xconnect 10.10.10.10 200 encapsulation mpls
exit
```



-
- Note** Removing the global CEM class that is associated with CEM interface/CEM group will remove the configuration from all the associated CEM.
-

Configuring CEM Parameters

The following sections describe the parameters you can configure for CEM circuits.

Configuring Payload Size (Optional)

To specify the number of bytes encapsulated into a single IP packet, use the payload size command. The size argument specifies the number of bytes in the payload of each packet. The range is from 32 to 1312 bytes.

Default payload sizes for an unstructured CEM channel are as follows:

- E1 = 256 bytes
- T1 = 192 bytes

Default payload sizes for a structured CEM channel depend on the number of time slots that constitute the channel. Payload size (L in bytes), number of time slots (N), and packetization delay (D in milliseconds) have the following relationship: $L = 8 * N * D$. The default payload size is selected in such a way that the packetization delay is always 1 millisecond.

The payload size must be an integer of the multiple of the number of time slots for structured CEM channels.

Setting the Dejitte Buffer Size

Dejitte Buffer is a buffering mechanism to account for a delay variation in the CEM packet stream. The buffer size is the amount of time you allocate to compensate for the network filter. The configured dejitter-buffer size is converted from milliseconds to packets and rounded up to the next integral number of packets. To set

the size of the dejitter-buffer (in milliseconds), use the **dejitter-buffer** *value* command. The value range is from 1 to 32; the default is 5.

Shutting Down a CEM Channel

To shut down a CEM channel, use the **shutdown** command in CEM configuration mode. The **shutdown** command is supported only under CEM mode and not under the CEM class.

Configuring DS1 CT3 SAToP Mode

To configure DS1 CT3 SAToP mode, use the following commands:

```
enable
configure terminal
controller MediaType
mode sonet
controller sonet 0/5/0
rate oc12
sts-1 1
mode ct3
t1 1 cem-group 100 unframed
t1 1 framing unframed
interface cem 0/5/0
cem 100
xconnect 2.2.2.2 10 encapsulation mpls
end
```

Configuring VT DS1 SAToP Mode

To configure VT DS1 SAToP mode, use the following commands:

```
enable
configure terminal
controller MediaType 0/5/0
mode sonet
controller sonet 0/5/0
rate oc12
sts-1 1
mode vt-15
vtg 1 t1 1 framing unframed
vtg 1 t1 1 cem-group 0 unframed
end
```

Configuring STS-Nc CEP

To configure STS-Nc CEP, use the following commands:

```
enable
configure terminal
controller MediaType 0/5/0
mode sonet
controller sonet 0/5/0
rate oc12
sts-1 1 - 3 mode sts-3c
cem-group 100 cep
interface cem 0/5/0
cem 100
```

```
xconnect 2.2.2.2 10 encapsulation mpls
end
```

Configuring CEP

To configure CEP:

```
enable
configure terminal
controller MediaType 0/5/0
mode sonet
controller sonet 0/5/0
sts-1 1
mode unframed
cem-group 100 cep
end
```

Configuring VT-15 CEP

To configure VT-15 CEP, use the following commands:

```
enable
configure terminal
controller MediaType 0/5/0
mode sonet
controller sonet 0/5/0
rate oc12
sts-1 1
mode vt-15
vtg 1 vt 1 cem-group 100 cep
end
```

Configuring DS3 SAToP

To configure DS3 SAToP, the STS-1 needs to be configured in mode T3. Use the following commands:

```
enable
configure terminal
controller MediaType 0/5/0
mode sonet
controller sonet 0/5/0
rate oc12
sts-1 1
mode t3
cem-group 100 unframed
interface cem 0/5/0
cem 100
xconnect 2.2.2.2 10 encapsulation mpls
end
```

Configuring CEM APS

To configure CEM APS, use the following commands:

```
enable
configure terminal
controller MediaType 0/5/0
mode sonet
```



```

controller sonet 0/5/0
controller sonet-acr acr_no
sts-1 1
vtg 1 t1 1 cem-group 100 unframed
end

```

Configuring Unidirectional APS for SAToP



Note When the **aps adm** command is not used, the LOS is detected on active port and the L-AIS is transmitted to the remote-end to force APS switchover. This is similar to bi-directional APS mode.

'When the **aps adm** command is used, the ports are in strict unidirectional mode. When the LOS is detected on active port, the L-AIS is suppressed and behaves in a strict uni-directional mode.

Ensure that the configuration is performed under the protected interface.

To configure unidirectional ACR (SONET Framing), use the following commands:

```

enable
configure terminal
controller sonet 0/5/0
clock source internal
aps group acr 1
aps working 1
aps unidirectional
exit
controller sonet 0/4/0
aps group acr 1
aps protect 1 10.7.7.7
aps revert 3
aps adm
end

```



Note To restore the system to its default condition, use the **no** form of the command.

Configuring Bi-directional ACR (SONET Framing) for SAToP

To configure bi-directional ACR (SONET Framing), use the following commands:

```

enable
configure terminal
controller sonet 0/5/0
clock source internal
aps group acr 1
aps working 1
exit
controller sonet 0/4/0
aps group acr 1
aps protect 1 10.7.7.7
end

```



Note To restore the system to its default condition, use the **no** form of the command.

Verifying CEM Statistics for SAToP

Use the following commands to verify the pseudowire configuration for SAToP:

- **show cem circuit**—Displays information about the circuit state, administrative state, the CEM ID of the circuit, and the interface on which it is configured. If cross connect is configured under the circuit, the command output also includes information about the attachment circuit status.

```
Router# show cem circuit
```

```
<0-32000>      CEM ID
detail        Detailed information of cem ckt(s)
interface     CEM Interface
summary       Display summary of CEM ckts
|            Output modifiers
```

```
Router# show cem circuit
```

CEM Int.	ID	Line	Admin	Circuit	AC
CEM0/1/0	1	UP	UP	ACTIVE	--/--
CEM0/1/0	2	UP	UP	ACTIVE	--/--
CEM0/1/0	3	UP	UP	ACTIVE	--/--
CEM0/1/0	4	UP	UP	ACTIVE	--/--
CEM0/1/0	5	UP	UP	ACTIVE	--/--

- **show cem circuit cem-id** — Displays the detailed information about that particular circuit.

```
Router# show cem circuit 0
```

```
CEM0/1/2, ID: 0, Line: UP, Admin: UP, Ckt: ACTIVE
Controller state: up, T1 state: up
Idle Pattern: 0xFF, Idle CAS: 0x8
Dejitter: 5 (In use: 0)
Payload Size: 192
Framing: Unframed
CEM Defects Set
None
```

```
Signalling: No CAS
RTP: No RTP
```

```
Ingress Pkts:   11060           Dropped:           0
Egress Pkts:   11061           Dropped:           0
```

```
CEM Counter Details
Input Errors:   0           Output Errors:     0
Pkts Missing:  0           Pkts Reordered:   0
Misorder Drops: 0           JitterBuf Underrun: 0
Error Sec:     0           Severly Errored Sec: 0
Unavailable Sec: 0         Failure Counts:    0
Pkts Malformed: 0         JitterBuf Overrun: 0
```

- **show cem circuit summary** — Displays the number of circuits which are up or down per interface basis.

```
Router# show cem circuit summary
```

```
CEM Int.          Total Active  Inactive
```

 CEM0/1/0 1 1 0

Associated Commands

The following commands are used to configure CEM:

Commands	URL
cem	http://www.cisco.com/c/en/us/td/docs/ios-xml/ios/interface/command/ir-cr-book/ir-c1.html#wp2184138077
cem group <i>cem-group-number</i> unframed	http://www.cisco.com/c/en/us/td/docs/ios-xml/ios/interface/command/ir-cr-book/ir-c1.html#wp2440628600
cem-group <i>cem-group-number</i> cep	http://www.cisco.com/c/en/us/td/docs/ios-xml/ios/interface/command/ir-cr-book/ir-c1.html#wp2440628600
class cem	http://www.cisco.com/c/en/us/td/docs/ios-xml/ios/interface/command/ir-cr-book/ir-c1.html#wp7199841750
controller t1	http://www.cisco.com/c/en/us/td/docs/ios-xml/ios/interface/command/ir-cr-book/ir-c2.html#wp1472647421
mode ct3	http://www.cisco.com/c/en/us/td/docs/ios-xml/ios/interface/command/ir-cr-book/ir-l2.html#wp5913349630
mode t3	http://www.cisco.com/c/en/us/td/docs/ios-xml/ios/interface/command/ir-cr-book/ir-l2.html#wp5688885940
mode vt-15	http://www.cisco.com/c/en/us/td/docs/ios-xml/ios/interface/command/ir-cr-book/ir-l2.html#wp1137973905
payload-size dejitter-buffer	http://www.cisco.com/c/en/us/td/docs/ios-xml/ios/interface/command/ir-cr-book/ir-o1.html#wp3946673156
rate	http://www.cisco.com/c/en/us/td/docs/ios-xml/ios/interface/command/ir-cr-book/ir-o1.html#wp4442889730
show cem circuit	http://www.cisco.com/c/en/us/td/docs/ios-xml/ios/interface/command/ir-cr-book/ir-s2.html#wp1086825073
sts-1	http://www.cisco.com/c/en/us/td/docs/ios-xml/ios/interface/command/ir-cr-book/ir-s6.html#wp2423232697

Commands	URL
t1 t1-line-number cem-group	http://www.cisco.com/c/en/us/td/docs/ios-xml/ios/interface/command/ir-cr-book/ir-t1.html#wp2399838226
t1 t1-line-number framing	http://www.cisco.com/c/en/us/td/docs/ios-xml/ios/interface/command/ir-cr-book/ir-t1.html#wp2623191253
t1 t1-line-number clock source	http://www.cisco.com/c/en/us/td/docs/ios-xml/ios/interface/command/ir-cr-book/ir-t1.html#wp3480850667
vtg vtg-number vt vt-line-number cem-group cem-group-number cep	http://www.cisco.com/c/en/us/td/docs/ios-xml/ios/interface/command/ir-cr-book/ir-t2.html#wp3494199143
xconnect	http://www.cisco.com/c/en/us/td/docs/ios-xml/ios/interface/command/ir-cr-book/ir-t2.html#wp8578094790
show controllers t3	https://www.cisco.com/c/en/us/td/docs/ios-xml/ios/interface/command/ir-cr-book/ir-s3.html#wp1987423547

Additional References for Configuring CEM

Related Documents

Related Topic	Document Title
Cisco IOS commands	<i>Cisco IOS Master Commands List, All Releases</i>

Standards

Standards	Title
—	There are no standards for this feature.

MIBs

MIB	MIBs Link
—	To locate and download MIBs for selected platforms, Cisco IOS releases, and feature sets, use Cisco MIB Locator found at the following URL: http://www.cisco.com/go/mibs

RFCs

RFCs	Title
—	There are no RFCs for this feature.

Technical Assistance

Description	Link
<p>The Cisco Support website provides extensive online resources, including documentation and tools for troubleshooting and resolving technical issues with Cisco products and technologies.</p> <p>To receive security and technical information about your products, you can subscribe to various services, such as the Product Alert Tool (accessed from Field Notices), the Cisco Technical Services Newsletter, and Really Simple Syndication (RSS) Feeds.</p> <p>Access to most tools on the Cisco Support website requires a Cisco.com user ID and password.</p>	http://www.cisco.com/cisco/web/support/index.html



CHAPTER 2

CEM over MPLS QoS

The QoS EXP matching feature allows you to classify and mark network traffic by modifying the Multiprotocol Label Switching (MPLS) experimental bits (EXP) field in IP packets. This module contains conceptual information and the configuration tasks for classifying and marking network traffic using the MPLS EXP field.

This QoS EXP matching feature is supported on the following CEM interface modules:

- 48-Port T1 or E1 CEM interface module
- 48-Port T3 or E3 CEM interface module
- 1-port OC-48/STM-16 or 4-port OC-12/OC-3 / STM-1/STM-4 + 12 port T1/E1 + 4-port T3/E3 CEM interface module
- 1-port OC-192 or 8-port Low rate CEM interface module
-
- [Finding Feature Information, on page 15](#)
- [Information About CEM over MPLS QoS, on page 16](#)
- [How to Classify and Mark MPLS EXP, on page 17](#)
- [Configuration Examples, on page 18](#)
- [Additional References for CEM over MPLS QoS, on page 20](#)

Finding Feature Information

Your software release may not support all the features documented in this module. For the latest caveats and feature information, see [Bug Search Tool](#) and the release notes for your platform and software release. To find information about the features documented in this module, and to see a list of the releases in which each feature is supported, see the feature information table.

Use Cisco Feature Navigator to find information about platform support and Cisco software image support. To access Cisco Feature Navigator, go to <https://cfng.cisco.com/>. An account on Cisco.com is not required.

Information About CEM over MPLS QoS

Classifying and Marking MPLS EXP Overview

The QoS EXP matching feature allows you to organize network traffic by setting values for the MPLS EXP field in MPLS packets. By choosing different values for the MPLS EXP field, you can mark packets so that packets have the priority that they require during periods of congestion. Setting the MPLS EXP value allows you to:

- Classify traffic

The classification process selects the traffic to be marked. Classification accomplishes this by partitioning traffic into multiple priority levels, or classes of service. Traffic classification is the primary component of class-based QoS provisioning.

- Police and mark traffic

Policing causes traffic that exceeds the configured rate to be discarded or marked to a different drop level. Marking traffic is a way to identify packet flows to differentiate them. Packet marking allows you to partition your network into multiple priority levels or classes of service.

Prerequisites for CEM over MPLS QoS

The device must be configured as an MPLS provider edge (PE) or provider (P) chassis, which can include the configuration of a valid label protocol and underlying IP routing protocols.

Restrictions for CEM over MPLS QoS

- MPLS classification and marking can only occur in an operational MPLS Network.
- MPLS EXP classification and marking is supported on the main chassis interfaces for MPLS packet switching and imposition (simple IP imposition and Ethernet over MPLS (EoMPLS) imposition) and on Ethernet virtual circuits (EVCs) or Ethernet flow points (EFPs) for EoMPLS imposition.
- MPLS EXP topmost classification is not supported for bridged MPLS packets on Ethernet virtual circuits (EVC) or Ethernet flow points (EFP).
- MPLS EXP marking in the ingress direction only.
- If a packet is classified by IP type of service (ToS) or class of service (CoS) at ingress, it cannot be reclassified by MPLS EXP at egress (imposition case). However, if a packet is classified by MPLS at ingress it can be reclassified by Quality of Service (QoS) group at egress (disposition case).
- If a packet is encapsulated in MPLS, the MPLS payload cannot be checked for other protocols such as IP for classification or marking. Only MPLS EXP marking affects packets encapsulated by MPLS.

How to Classify and Mark MPLS EXP

Classifying MPLS Encapsulated Packets

You can use the **match mpls experimental topmost** command to define traffic classes based on the packet EXP values, inside the MPLS domain. You can use these classes to define services policies to mark the EXP traffic using the **police** command.

```
enable
configure terminal
class-map [match-all | match-any] class-map-name
match mpls experimental topmost mpls-exp-value
end
```

Marking MPLS EXP on Imposed Labels

In typical configurations, marking MPLS packets at imposition is used with ingress classification on IP ToS or CoS fields. However, generic matching with the class default value is supported with other ingress attributes such as **vlan**.



Note For EVC configuration, a policy map that performs matching based on the CoS, and that sets the EXP imposition value, should be used to copy CoS values to the EXP value.



Note The **set mpls experimental imposition** command works only on packets that have new or additional MPLS labels added to them.

```
enable
configure terminal
policy-map policy-map-name
class class-map-name
set mpls experimental imposition mpls-exp-value
end
```

Classifying and Marking MPLS EXP



Note The **set mpls experimental topmost** command works only on packets that are already MPLS encapsulated.

```
enable
configure terminal
policy-map policy-map-name
class class-map-name
set mpls experimental topmost mpls-exp-value
end
```

Configuration Examples

Example: Defining an MPLS EXP Class Map

Example: Defining an MPLS EXP Class Map

The following example defines a class map named exp3 that matches packets that contains MPLS experimental value 3:

```
Router(config)# class-map exp3
Router(config-cmap)# match mpls experimental topmost 3
Router(config-cmap)# exit
```

Example: Defining a Policy Map and Applying the Policy Map to an Ingress Interface

Example: Defining a Policy Map and Applying the Policy Map to an Ingress Interface

The following example uses the class map created in the example above to define a policy map. This example also applies the policy map to a physical interface for ingress traffic.

```
Router(config)# policy-map change-exp-3-to-2
Router(config-pmap)# class exp3
Router(config-pmap-c)# set mpls experimental topmost 2
Router(config-pmap)# exit
Router(config)# interface GigabitEthernet 0/0/0
Router(config-if)# service-policy input change-exp-3-to-2
Router(config-if)# exit
```

Example: Defining a Policy Map and Applying the Policy Map to an Egress Interface

Example: Defining a Policy Map and Applying the Policy Map to an Egress Interface

The following example uses the class map created in the example above to define a policy map. This example also applies the policy map to a physical interface for egress traffic.

```
Router(config)# policy-map WAN-out
Router(config-pmap)# class exp3
Router(config-pmap-c)# shape average 10000000
Router(config-pmap-c)# exit
Router(config-pmap)# exit
Router(config)# interface GigabitEthernet 0/0/0
Router(config-if)# service-policy output WAN-out
Router(config-if)# exit
```

Example: Defining an MPLS EXP Imposition Policy Map

Example: Defining an MPLS EXP Imposition Policy Map

The following example defines a policy map that sets the MPLS EXP imposition value to 2 based on the IP precedence value of the forwarded packet.

```
Router# configure terminal
Enter configuration commands, one per line. End with CNTL/Z.
Router(config)# class-map prec012
Router(config-cmap)# match ip prec 0 1 2
Router(config-cmap)# exit
Router(config)# policy-map mark-up-exp-2
Router(config-pmap)# class prec012
Router(config-pmap-c)# set qos-group 3
Router(config-pmap-c)# exit
Router(config-pmap)# exit
```

Example: Applying the MPLS EXP Imposition Policy Map to a Main Interface

Example: Applying the MPLS EXP Imposition Policy Map to a Main Interface

The following example applies a policy map to Gigabit Ethernet interface 0/0/0:

```
Router# configure terminal
Enter configuration commands, one per line. End with CNTL/Z.
Router(config)# interface GigabitEthernet 0/0/0
Router(config-if)# service-policy input mark-up-exp-2
Router(config-if)# exit
```

Example: Applying the MPLS EXP Imposition Policy Map to an EVC

Example: Applying the MPLS EXP Imposition Policy Map to an EVC

The following example applies a policy map to the Ethernet Virtual Connection specified by the **service instance** command:

```
Router# configure terminal
Enter configuration commands, one per line. End with CNTL/Z.
Router(config)# interface GigabitEthernet 0/0/0
Router(config-if)# service instance 100 ethernet
Router(config-if-srv)# xconnect 100.0.0.1 encapsulation mpls 100
Router(config-if-srv)# service-policy input mark-up-exp-2
Router(config-if-srv)# exit
Router(config-if)# exit
```

Example: Defining an MPLS EXP Label Switched Packets Policy Map

Example: Defining an MPLS EXP Label Switched Packets Policy Map

The following example defines a policy map that sets the MPLS EXP topmost value to 2 according to the MPLS EXP value of the forwarded packet:

```
Router# configure terminal
Enter configuration commands, one per line. End with CNTL/Z.
Router(config)# class-map exp012
Router(config-cmap)# match mpls experimental topmost 0 1 2
Router(config-cmap)# exit
Router(config-cmap)# policy-map mark-up-exp-2
Router(config-pmap)# class exp012
Router(config-pmap-c)# set mpls experimental topmost 2
Router(config-pmap-c)# exit
Router(config-pmap)# exit
```

Example: Applying the MPLS EXP Label Switched Packets Policy Map to a Main Interface

Example: Applying the MPLS EXP Label Switched Packets Policy Map to a Main Interface

The following example shows how to apply the policy map to a main interface:

```
Router# configure terminal
Enter configuration commands, one per line. End with CNTL/Z.
Router(config)# interface GigabitEthernet 0/0/0
Router(config-if)# service-policy input mark-up-exp-2
Router(config-if)# exit
```

Additional References for CEM over MPLS QoS

Related Documents

Related Topic	Document Title
Cisco IOS commands	Cisco IOS Master Commands List, All Releases

Standards

Standards	Title
—	There are no standards for this feature.

MIBs

MIB	MIBs Link
—	To locate and download MIBs for selected platforms, Cisco IOS releases, and feature sets, use Cisco MIB Locator found at the following URL: http://www.cisco.com/go/mibs

RFCs

RFCs	Title
—	There are no RFCs for this feature.

Technical Assistance

Description	Link
<p>The Cisco Support website provides extensive online resources, including documentation and tools for troubleshooting and resolving technical issues with Cisco products and technologies.</p> <p>To receive security and technical information about your products, you can subscribe to various services, such as the Product Alert Tool (accessed from Field Notices), the Cisco Technical Services Newsletter, and Really Simple Syndication (RSS) Feeds.</p> <p>Access to most tools on the Cisco Support website requires a Cisco.com user ID and password.</p>	http://www.cisco.com/cisco/web/support/index.html



CHAPTER 3

Configuring SONET

This module describes how to configure Synchronous Optical Network (SONET). SONET defines optical signals and a synchronous frame structure for multiplexed digital traffic. SONET equipment is generally used in North America.

The transport network using SONET provides much more powerful networking capabilities than existing asynchronous systems.

- [Overview of SONET, on page 24](#)
- [Restrictions for SONET, on page 24](#)
- [SONET Switching , on page 25](#)
- [SONET Hierarchy, on page 26](#)
- [STS-1 and STS-3 Frames, on page 27](#)
- [SONET Line and Section Configuration Parameters, on page 28](#)
- [BERT, on page 29](#)
- [Concatenated SONET Frames, on page 30](#)
- [SONET Path Level Configuration Parameters, on page 30](#)
- [Channelized SONET Frames, on page 31](#)
- [SONET T1 Configuration Parameters, on page 31](#)
- [SONET T3 Configuration Parameters, on page 31](#)
- [SONET VT Configuration Parameters, on page 32](#)
- [Automatic Protection Switching , on page 32](#)
- [How to Configure SONET, on page 37](#)
- [Configuring Port Rate and Verifying Pluggables, on page 64](#)
- [Configuring BERT in Sonet for CESoPSN, on page 66](#)
- [Loopback Remote on T1 and T3 Interfaces, on page 68](#)
- [Clock Recovery System in CESoPSN, on page 70](#)
- [Configuring Clocking for ACR and DCR on APS for CESoPSN, on page 75](#)
- [Configuring VT-15 mode of STS-1 for Framed SAToP, on page 79](#)
- [Configuring DS1/T1 CT3 mode of STS-1 for Framed SAToP, on page 80](#)
- [Verifying SONET Configuration for Framed SAToP, on page 80](#)
- [Associated Commands, on page 81](#)
- [Additional References for Configuring SONET on 1-Port OC192/STM-64 or 8-Port OC3/12/48/STM-1/-4/-16 Interface Module, on page 83](#)

Overview of SONET

SONET is a set of standards that define the rates and formats for optical networks specified in GR-253-CORE. SONET is based on a structure that has a basic frame format and speed. The frame format used by SONET is the Synchronous Transport Signal (STS), with STS-1 as the base-level signal at 51.84 Mbps. An STS-1 frame can be carried in an OC-1 signal.

SONET has a hierarchy of signaling speeds.

Restrictions for SONET

- Rate combinations are 0-1, 2-3, 4-5, 6-7 and 8. A maximum rate of 4XOC-48 is supported on ports 0-7. 4XOC-48 can be configured in any one port of a port-group and other port is not used.
- Only 16 BERT Patterns can be configured at a time on 1-Port OC192/STM-64 or 8-Port OC3/12/48/STM-1/-4/-16 Module.
- VT1.5 VT cannot be configured if VT1.5 T1/DS1 is configured with the same KLM value.
- PMON fields are not supported for VT1.5 VT and DS3 or T3.
- PMON Far-end parameters are not supported.

Restrictions on Bandwidth

- Total available bandwidth for 1-Port OC192/STM-64 or 8-Port OC3/12/48/STM-1/-4/-16 Module is 10G.

The following configuration is blocked and an error message is displayed after the maximum bandwidth is utilized:

```
rate OC3| OC12| OC48| OC192
```

The bandwidth of adjacent ports should not exceed OC-48.

The following table shows the bandwidth used by different rates:

Table 5: Bandwidth Used by Different Rates

Rate	Bandwidth
OC-3	155.52 Mbps
OC-12	622.08 Mbps
OC-48	2.4 Gbps
OC-192	9.6 Gbps

Restrictions for Clock Source Configuration

- Only 4 ports can be configured in SONET line for clock source configuration per chassis.

- You should configure the clock source line and network-clock sync together to receive the clock from a remote port that is connected to the SONET port.

SONET Switching

SONET Switching is achieved on optical interface modules by circuit emulation. Circuit Emulation (CEM) is a way to carry TDM circuits over packet switched network. CEM embeds TDM bits into packets, encapsulates them into an appropriate header and then sends that through Packet Switched Network (PSN). The receiver side of CEM restores the TDM bit stream from packets.

Modes of CEM:

- **Structure Agnostic TDM over Packet (SAToP)** (RFC 4553) – Structure-Agnostic TDM over Packet (SAToP) mode is used to encapsulate T1/E1 or T3/E3 unstructured (unchannelized) services over packet switched networks. In SAToP mode, the bytes are sent out as they arrive on the TDM line. Bytes do not have to be aligned with any framing.

In this mode, the interface is considered as a continuous framed bit stream. The packetization of the stream is done according to IETF RFC 4553. All signaling is carried transparently as a part of a bit stream.

- **Circuit Emulation Service over Packet (CEP)** (RFC 4842) - CEP mode is used to encapsulate SONET payload envelopes (SPEs) like VT1.5 or VT2 or STS-1 or STS-Nc over packet switched networks. In this mode, the bytes from the corresponding SPE are sent out as they arrive on the TDM line. The interface is considered as a continuous framed bit stream. The packetization of the stream is done according to IETF RFC 4842.

Table 6: Modes of CEM

Mode	CEM	Ports
STS-48C	CEP	OC-48, OC-192
STS-12C	CEP	OC-12, OC-48, OC-192
STS-3C	CEP	OC-3, OC-12, OC-48, OC-192
STS-1	CEP	OC-3, OC-12, OC-48, OC-192
DS3	SAToP	OC-3, OC-12, OC-48, OC-192
DS3-T1	SAToP	OC-3, OC-12, OC-48, OC-192
VT 1.5	CEP	OC-3, OC-12, OC-48, OC-192
VT 1.5	CESoPSN	OC-3, OC-12, OC-48, OC-192
CT3-T1	CESoPSN	OC-3, OC-12, OC-48, OC-192

STS-1 and STS-3 Frames

A standard STS-1 frame is nine rows by 90 bytes. The first three bytes of each row represent the Section and Line overhead. These overhead bits comprise framing bits and pointers to different parts of the SONET frame.

Figure 2: STS-1 Frame Structure

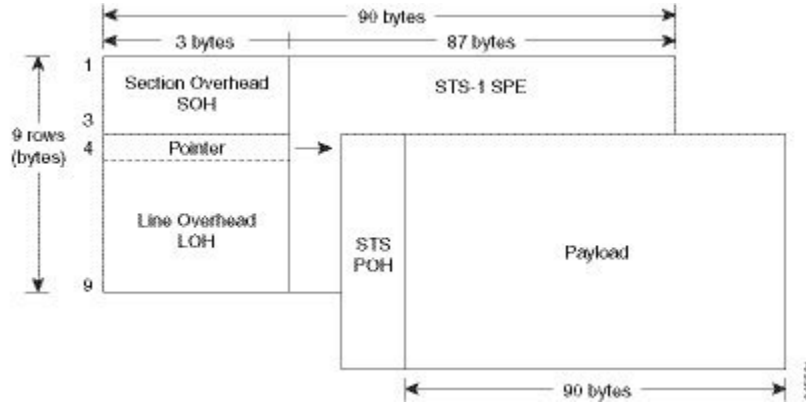

There is one column of bytes in the payload that represents the STS path overhead. This column frequently "floats" throughout the frame. Its location in the frame is determined by a pointer in the Section and Line overhead.

The combination of the Section and Line overhead comprises the transport overhead, and the remainder is the SPE.

Figure 3: STS-1 SONET Overhead

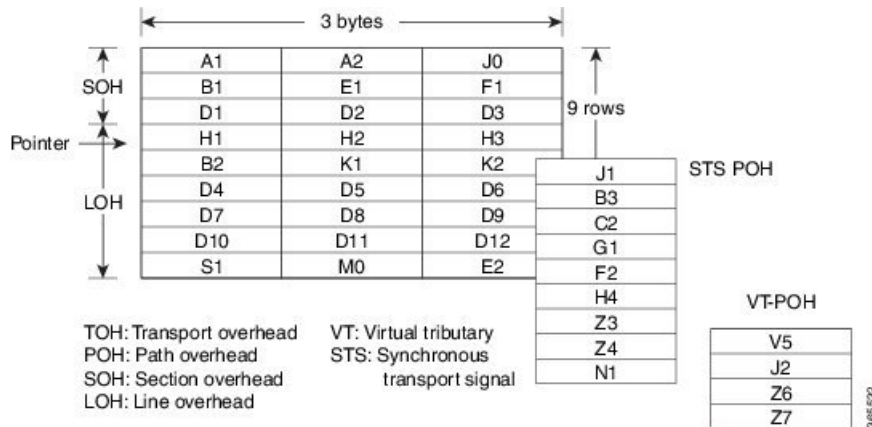

For STS-1, a single SONET frame is transmitted in 125 microseconds, or 8000 frames per second. $8000 \text{ fps} * 810 \text{ B/frame} = 51.84 \text{ Mbs}$, of which the payload is roughly 49.5 Mbs, enough to encapsulate 28 DS-1s, a full DS-3, or 21 CEPT-1s.

An STS-3 frame is nine rows by 270 bytes. The first nine columns contain the transport overhead section, and the rest is SPE. For both STS-3 and STS-3c, the transport overhead (Line and Section) is the same.

For an STS-3 frame, the SPE contains three separate payloads and three separate path overhead fields. In essence, it is the SPE of three separate STS-1s packed together, one after another.

For more information on Section Overhead, Line Overhead, and Path Overhead, refer the following:

- <http://www.cisco.com/c/en/us/support/docs/optical/synchronous-digital-hierarchy-sdh/5462-sdh-overview.html>
- <http://www.cisco.com/c/en/us/support/docs/optical/synchronous-optical-network-sonet/13567-sonet-tech-tips.html>
- <http://www.cisco.com/c/en/us/tech/optical/synchronous-optical-network-sonet/tsd-technology-support-troubleshooting-technotes-list.html>

SONET Line and Section Configuration Parameters

The following parameters affect SONET configuration at the line and section levels:

- **Overhead** — Sets the SONET overhead bytes in the frame header to a specific standards requirement, or to ensure interoperability with equipment from another vendors.
 - **J0** — Sets the J0 or C1 byte value in the SONET section overhead.



Note 1 byte, 16 bytes, and 64 bytes are the supported values for J0.

- **S1S0** — Sets the SS bits value of the H1 byte in the SONET line overhead.
- **Loopback** — Sets a loopback to test the SONET port.
- **AIS-Shut** — Configures the SONET port to send the Alarm Indication Signal (AIS) at shutdown.
- **Shut** — Disables an interface.
- **Alarm Reporting** — Enables reporting for all or selected alarms.
 - **lias** — Enables line alarm indication signal.
 - **lrldi** — Enables line remote defect indication signal.
 - **pais** — Enables path alarm indication signal.
 - **plop** — Enables loss of pointer failure signal for a path.
 - **pplm** — Enables path payload mismatch indication.
 - **prdi** — Enables path remote defect indication signal.
 - **sd-ber** — Sets Signal Degrade BER threshold.
- **Clock** — Specifies the clock source, where:
 - **line** — The link uses the recovered clock from the line.
 - **internal** — The link uses the internal clock source. This is the default setting.

BERT

Bit-Error Rate Testing (BERT) is used for analyzing quality and for problem resolution of digital transmission equipment. BERT tests the quality of an interface by directly comparing a pseudorandom or repetitive test pattern with an identical locally generated test pattern.

The BERT operation is data-intensive. Regular data cannot flow on the path while the test is in progress. The path is reported to be in alarm state when BERT is in progress and restored to a normal state after BERT has been terminated.

BERT is supported in the following two directions:

- Line—Supports BERT in TDM direction.
- System—Supports BERT in PSN direction.

BERT Patterns on 1-Port OC-192 or 8-Port Low Rate CEM Interface Module

Table 7: Feature History

Feature Name	Release Information	Description
Support for all 0s and 1s BERT Patterns	Cisco IOS XE Bengaluru 17.4.1	Support for all 0s and 1s BERT patterns for SONET and SDH.

The BERT patterns on the 1-Port OC-192 or 8-Port Low Rate CEM interface module are:

Table 8: BERT Pattern Descriptions

Keyword	Description
All 0s	Pseudo-random binary test pattern consisting of all 0's that is used for test line coding.
All 1s 3	Pseudo-random binary test pattern consisting of all 1's that is used to test alternating line volt and repeaters.
2^15-1 O.151	Pseudo-random O.151 test pattern consisting of a maximum of 14 consecutive zeros and 15 consecutive ones. The length of this pattern is 32,768 bits.
2^20-O.151	Pseudo-random O.151 test pattern consisting of a maximum of 19 consecutive zeros and 20 consecutive ones. The length of this pattern is 1,048,575 bits.
2^20-O.153	Pseudo-random O.153 test pattern consisting of a maximum of 19 consecutive zeros and 20 consecutive ones. The length of this pattern is 1,048,575 bits.

Keyword	Description
2²³-1 O.151	Pseudo-random 0.151 test pattern consisting of a maximum of 22 consecutive zeros and 23 consecutive ones. The length of this pattern is 8,388,607 bits.
2⁹-1 4	Pseudo-random binary test pattern consisting of a maximum of eight consecutive zeros and nine consecutive ones. The length of this pattern is 511 bits.
2¹¹-1 5	Pseudo-random binary test pattern consisting of a maximum of ten consecutive zeros and eleven consecutive ones. The length of this pattern is 2048 bits.

³ All 1s are supported only on SONET CT3, SDH AU-3 - CT3/CE3 - T1/E1, and SDH AU-3 - VC3. Starting with Cisco IOS XE Bengaluru 17.4.1, All 1s are supported on all modes.

⁴ Starting with Cisco IOS XE Bengaluru 17.4.1, 2⁹ mode is supported.

2⁹ is not supported on the following modes:

- SONET—Unframed, STS-3c, STS-12c, and STS-48c.
- SDH AU-4—VC4, TUG-3-VC3, TUG-3-E3, TUG-3-T3, and TUG-3 - VC1x.
- SDH AU-3—VC3, VC4-4c, VC4-16c, and VC1x.

⁵ Starting with Cisco IOS XE Bengaluru 17.4.1, 2¹¹ mode is supported.

2¹¹ is not supported on the following modes:

- SONET—Unframed, STS-3c, STS-12c, and STS-48c.
- SDH AU-4—VC4 and TUG-3-VC3.
- SDH AU-3—VC3, VC4-4c, and VC4-16c.

Concatenated SONET Frames

Twenty-eight VTs make up one STS-1. Three STS-1s make up an STS-3 and so on. Any one byte within the STS frame has a direct relationship to a base VT that helps to make up the STS.

A lower-case "c" in the STS rate stands for "concatenated", and indicates that the interface hardware is not channelized. Examples of concatenated interfaces are STS-3c and STS-12c.

The STS-1s may be concatenated into sets of 3 or 12 or 24 or 48 or 192 to form STS-3c, STS-12c, and so on. The STS-1s may be combined only at specific STS-n boundaries within an OC port.

SONET Path Level Configuration Parameters

The following parameters affect SONET configuration at the path level:

- **BERT** — Starts the BERT test.
- **Clock** — Specifies the clock source for a path.
- **Exit** — Exits from SONET path configuration mode.
- **Loopback** — Sets the entire path in the loopback mode.
- **Mode** — Specifies the path operation mode.
- **No** — Negates a command or sets its defaults.
- **Overhead** — Configures SONET path overhead flags.
- **Shutdown** — Disables the SONET path.
- **Threshold** — Sets the path BER threshold values.
- **vtg** — Sets the VT-15 configuration.

Channelized SONET Frames

A channelized SONET interface is a composite of lower-speed STS streams. However, a channelized SONET interface maintains the streams as independent frames with unique payload pointers. The frames are simply multiplexed before transmission to increase the carrying capacity of the physical fiber. This process is similar to multiplexing 24 digital signal level 0 channels into a DS1 or multiplexing 28 DS1 streams into a DS3.

SONET T1 Configuration Parameters

The following parameters affect SONET T1 configuration:

- **BERT** — Starts the BERT test.
- **Clock** — Specifies the clock source for T1 interface.
- **Description** — Specifies the description of the controller.
- **Framing** — Specifies the type of a framing on T1 interface.
- **Loopback** — Sets the T1 interface in the loopback mode.
- **Shutdown** — Disables the T1 interface.

SONET T3 Configuration Parameters

The following parameters affect SONET T3 configuration:

- **Clock** — Specifies the clock source for T3 link.
- **Description** — Specifies the description of the controller.
- **Framing** — Specifies the type of a framing on T3 interface.

- **Loopback** — Sets the T3 link in the loopback mode.
- **Shutdown** — Disables the T3 interface.

SONET VT Configuration Parameters

The following parameters affect SONET VT configuration:

- **BERT** — Starts the BERT test.
- **CEM Group** — Specifies the time slots for CEM group mapping.
- **Clock** — Specifies the clock source for VT.
- **Description** — Specifies the description of the controller.
- **Loopback** — Sets the VT in the loopback mode.
- **Overhead** — Configures VT line path overhead flags.
- **Shutdown** — Disables the VT interface.
- **Threshold** — Configures the VT threshold values.

Automatic Protection Switching

Table 9: Feature History

Feature Name	Release Information	Feature Description
IMA3G 1+1 OC3/12 Single Card APS Support	Cisco IOS XE Amsterdam 17.3.1	Automatic protection switching (APS) is a protection mechanism for SONET networks that enables SONET connections to switch to another SONET circuit when a circuit failure occurs. This protection schemes allows a pair of SONET lines or paths to be configured for line or path redundancy. In the event of a fiber cut, the active line or path switches automatically to the standby line or path. In the 1+1 architecture, there is one working interface (circuit) and one protection interface, and the same payload from the transmitting end is sent to both the receiving ends. The receiving end decides which interface to use.

Feature Name	Release Information	Feature Description
CEM and IP IW Feature Parity for Interface Modules	Cisco IOS XE Bengaluru 17.4.1	Support for APS and non-APS on SDH and SONET for iMSG IPv6 interworking on Interface Module.

Automatic protection switching (APS) is a protection mechanism for SONET networks that enables SONET connections to switch to another SONET circuit when a circuit failure occurs. A protection interface serves as the backup interface for the working interface. When the working interface fails, the protection interface quickly assumes its traffic load.

The SONET protection schemes comply with GR-253 and ITU-T G.783. It allows Optical Interface Module to work seamlessly as SONET Add or Drop Multiplexers (ADM)s. The implementation of the above protection schemes allows a pair of SONET lines or paths to be configured for line or path redundancy. In the event of a fiber cut, the active line or path switches automatically to the standby line or path in up to 60 milliseconds (2/5/10 millisecond for holdover and 50 millisecond switchovers).

Optical Interface Module supports the following SONET protection switching schemes:

- Linear Bidirectional 1+1 APS
- Linear Unidirectional 1+1 APS

1+1 APS

In the 1+1 architecture, there is one working interface (circuit) and one protection interface, and the same payload from the transmitting end is sent to both the receiving ends. The receiving end decides which interface to use. The line overhead (LOH) bytes (K1 and K2) in the SONET frame indicate both status and action.

The protection interfaces need to be configured with an IP address of the chassis that has the working interface, using APS commands. The APS Protect Group Protocol, which runs on top of UDP, provides communication between the process controlling the working interface and the process controlling the protection interface. Using this protocol, interfaces can be switched because of a chassis failure, degradation or loss of channel signal, or manual intervention. In bidirectional mode, the receive and transmit channels are switched as a pair.

Two SONET connections are required to support APS.

The following option is available for linear bidirectional 1+1 APS:

- Revertive option — For any failure on working line, the software switches to protection line and when the working line recovers, it waits based on the revertive timer and reverts back to working line as active link.
- Non-revertive option — When the signal fails, the software switches to the protection line and does not automatically revert back to the working line. This is the default option.

The following features are supported on 1+1 APS:

- SONET PW (SATO P or CEP)
- SONET local connect

Benefits of APS

The following lists the benefits of APS:

- APS performs switchovers with minimal loss of data and time-consuming reroutes are avoided.
- There is no visibility that a failure has occurred beyond the network element in which it is residing; other nodes are not affected by the failure.
- Implementation of APS guards a network against complex restarts and resynchronizations since failures are isolated to a local device.
- With APS, the effect of a failure is greatly minimized and a fast switchover guarantees minimal effect on the network.

APS 1+1 for SONET Layer 1 traffic

SONET linear APS 1+1 provides protection against both fiber cuts and front card or back card failures. APS 1+1 requires a redundant protection line for every working line. The traffic is simultaneously carried by the working and the protection lines. Hence, the receiver that terminates the APS 1+1 should select the traffic from one of the lines and continue to forward the traffic. APS 1+1 provides protection in unidirectional and bi-directional modes:

- **Uni-directional Protection:** The receiving end can switch from working to protection line without any coordination at the transmit end since both lines transmit the same information.
- **Bi-directional Protection:** The receiving end switches from working to protection line by coordinating at the transmit end.

Scenario for Bidirectional APS 1+1

In the above figure, two are connected to provide APS 1+1 bi-directional protection. The highlighted one is the working line and the other is the protection line. The traffic is transmitted on both working and protection lines and received only on one line.

In a scenario where you encounter a fiber cut,

1. There is a cable cut in the working line. So, the receives a Loss of Signal (LOS) on working line.
2. starts generating K2 byte and sends it to the over the protection line.
3. receives the K2 byte and reacts on the receiving K2 byte.
4. starts sending K1 byte to the on the protection line.
5. starts sending K2 byte to on the protection line.
6. receives the K1/K2 byte and starts receiving the data from protection line. The protection line now acts as the active line.
7. sends K2 byte over the new active line to . receives this signal and starts accepting the data from this new active line.

Scenario for Unidirectional APS 1+1

In the above figure, two are connected to provide APS 1+1 unidirectional protection. The figure shows a working line and a protection line. The traffic is transmitted on both working and protection line and received only on one line.

In a scenario where you encounter a fiber cut,

1. receives a LOS on RX working line.

2. detects LOS and starts receiving the data from the protection line. The protection line now becomes the active line.
3. receives the K2 byte and knows about switching event on device 2.

UPSR Path Protection

Table 10: Feature History

Feature Name	Release Information	Feature Description
CEM and IP IW Feature Parity for Interface Modules	Cisco IOS XE Bengaluru 17.4.1	Support for UPSR IPv6 on Interface Module.

A Unidirectional Path Switching Ring (UPSR) is a unidirectional network with two rings, one ring used as the working ring and the other as the protection ring. The same signal flows through both rings, one clockwise and the other counterclockwise. It is called UPSR because monitoring is done at the path layer. A node receives two copies of the electrical signals at the path layer, compares them, and chooses the one with the better quality. If part of a ring between two ADMs fails, the other ring still can guarantee the continuation of data flow. UPSR, like the one-plus-one scheme, has fast failure recovery.

Once a signal fail condition or a signal degrade condition is detected, the hardware initiates an interrupt to software that switches from the working path to the protection path. Nonrevertive options are valid for UPSR path protection.



Note 1X OC-192 and 8X OC-48 interface modules only supports the nonrevertive option. The nonrevertive option is the default mode.



Note When an active link of UPSR and APS is configured on the same interface module and the interface module reloads, the convergence number for UPSR circuits to switch to backup is high ranging 100–200 ms. When each circuit is configured separately, the convergence time is always under 50 ms.

The below table gives the maximum number of path level circuits that are supported in each mode.

Modes	Supported Scale
VT 1.5	84
STS-1	48
STS 3c	16
STS 12c	4
STS 48c	1

The UPSR path protection supports the following feature:

- SONET local connect and cross connect are supported at VT-15 CEP, STS-1c, STS-3c, STS-12c, and STS-48c levels. UPSR is also supported on TDM endpoints that are mapped to a pseudowire. T1 SAToP,

T3 SAToP, and CT3 are supported on an UPSR ring only with local connect mode. Cross connect of T1, T3, and CT3 circuits to UPSR are not supported until Cisco IOS XE Fuji 16.8.x.

Starting with Cisco IOS XE Fuji 16.9.x, the cross connect of T1, T3, and CT3 circuits to UPSR is supported. For xconnect with the CT3 mode, the CEM protection group interface only supports the VT-15 mode. For cross-connect configuration, see *Configuring UPSR*.

Configuring UPSR

Protection Group Configuration

```
enable
configure terminal
protection-group 401 type STS48c
controller protection-group 401
type STS48c
cem-group 19001 cep
end
```

Cross-connect Configuration with the CT3 mode

For cross connect with the CT3 mode, the CEM protection group interface supports only the VT-15 mode.

```
protection-group 2 type vt1.5
controller protection-group 2
type vt1.5
cem-group 16002 unframed

controller sonet 0/4/0
sts-1 1
mode vt-15
vtg 1 t1 2 protection-group 2 working

controller sonet 0/5/0
sts-1 1
mode vt-15
vtg 1 t1 2 protection-group 2 protect
```

Configuring UPSR Work and Protection Path Configuration

UPSR Work Path Configuration:

```
enable
configure terminal
controller MediaType 0/3/6
mode sonet
controller sonet 0/3/6
rate oc48
sts-1 1 - 48 mode sts-48c
protection-group 401 working
end
```

UPSR Protect Path Configuration:

```
enable
configure terminal
controller MediaType 0/12/6
mode sonet
controller sonet 0/12/6
rate oc48
sts-1 1 - 48 mode sts-48c
```

```
protection-group 401 protect
end
```

Verifying UPSR Configuration

Use the **show protection-group** command to verify UPSR configuration:

```
show protection-group
PGN   Type   Working I/f                               Protect I/f                               Active Status
-----
401   STS48C  SONET0/3/6.1-48                          SONET0/12/6.1-48                          W           A
-----
Status legend:D=Deleted FO=Force SF=SignalFailure SD=SignalDegrade
               FL=Fail M=Manual L=Lockout C=Clear A=Auto
(W)=working, (P)=protect
```

How to Configure SONET

This section describes how to configure SONET.

Each SFP port (0-7) can be configured as OC-3, OC-12, OC-48, or Gigabit Ethernet. SFP+ port (8) can be configured as OC-192 or 10 Gigabit Ethernet.

Prerequisites for Configuring SONET

You must select the MediaType controller to configure and enter the controller configuration mode.

You must configure the controller as a SONET port.

Configuring MediaType Controller

To configure MediaType Controller, use the following commands:

```
enable
configure terminal
controller MediaType 0/5/0
mode sonet
end
```

Configuring SONET Ports

To configure SONET ports, use the following commands:

```
enable
configure terminal
controller MediaType 0/5/0
mode sonet
controller sonet 0/5/0
rate OC12
end
```

The above example shows how to configure SONET ports in OC-12 mode.

Managing and Monitoring SONET Line

This section describes how to manage and monitor SONET.

Configuring Line and Section Overhead

To configure line and section overhead, use the following commands:

```
enable
configure terminal
controller MediaType 0/5/0
mode sonet
controller sonet 0/5/0
overhead s1s0 2
overhead j0 tx length 1-byte
end
```



Note To restore the system to its default condition, use the **no** form of the command.

Configuring Line and Section Threshold

To configure line and section threshold, use the following commands:

```
enable
configure terminal
controller sonet 0/5/0
threshold b2-tca 3
end
```



Note To restore the system to its default condition, use the **no** form of the command.

```
enable
configure terminal
controller sonet 0/5/0
threshold b2-tca 3
end
```



Note To restore the system to its default condition, use the **no** form of the command.

Configuring Line Loopback

To configure loopback, use the following commands:

```
enable
configure terminal
controller sonet 0/5/0
loopback local
end
```



Note To restore the system to its default condition, use the **no** form of the command.

Configuring AIS Shut

To configure AIS-Shut, use the following commands:

```
enable
configure terminal
controller sonet 0/5/0
ais-shut
end
```



Note The **no ais-shut** command will not send AIS.

Configuring Shut

To configure Shut, use the following commands:

```
enable
configure terminal
controller sonet 0/5/0
shutdown
end
```



Note Use the **no shutdown** command to disable the interface.

Configuring Alarm Reporting

To configure alarm reporting, use the following commands:

```
enable
configure terminal
controller sonet 0/5/0
alarm-report b2-tcs
end
```



Note To restore the system to its default condition, use the **no** form of the command.

Configuring Clock

To configure clock, use the following commands:

```
enable
configure terminal
controller MediaType 0/5/0
mode sonet
controller sonet 0/5/0
```

```
clock source line
end
```



Note The default mode is internal.



Note To restore the system to its default condition, use the **no** form of the command.

Configuring Network-Clock SONET

To configure network-clock SONET, use the following commands:

```
enable
configure terminal
network-clock input-source 1 controller sonet 0/5/0
end
```

Configuring STS-1 Modes

To configure STS-1 modes, use the following commands:

```
enable
configure terminal
controller sonet 0/5/0
sts-1 1
mode vt-15
end
```



Note There is no default mode. The following modes are supported:

- mode vt-15
 - mode ct3
 - mode cte-e1
 - mode t3
 - mode unframed
 - mode vt-2
-



Note To restore the system to its default condition, use the **no** form of the command.

Configuring DS1/T1 CT3 mode of STS-1

To configure DS1/T1 CT3 mode of STS-1, you can configure the T1 link using the following steps:

```
enable
configure terminal
```



```

controller sonet 0/5/0
sts-1 1
mode ct3
t1 1 clock source internal
t1 1 framing unframed
end

```



Note To restore the system to its default condition, use the **no** form of the command.

Configuring STS-Nc - Contiguous Concatenation

To configure STS-Nc - contiguous concatenation, use the following commands:

```

enable
configure terminal
controller sonet 0/5/0
sts-1 1-3 mode sts-3c
end

```



Note To restore the system to its default condition, use the **no** form of the command.



Note To configure STS-3c or STS-12c, use the numbers as multiples for 3 or 12, respectively.

Configuring CEM Group for Sonet Mode VT1.5-T1 in CESoPSN

To configure CEM group in VT 1.5 mode of STS-1 for CESoPSN, use the following commands:

```

enable
configure terminal
controller sonet 0/5/0
sts-1 2
mode vt-15
vtg 1 t1 1 cem-group 56 timeslots 1 - 8
end

```

Configuring CEM Group for Sonet Mode CT3-T1 in CESoPSN

To configure CEM group in CT3 mode of STS-1 for CESoPSN, use the following commands:

```

enable
configure terminal
controller sonet 0/5/0
sts-1 1
mode ct3
t1 3 cem-group 28 timeslots 1 - 7
end

```

Configuring APS for SAToP

This section describes the configuration of APS for SAToP.

Configuring Bi-directional ACR (SONET Framing) for SAToP

To configure bi-directional ACR (SONET Framing), use the following commands:

```
enable
configure terminal
controller sonet 0/5/0
clock source internal
aps group acr 1
aps working 1
exit
controller sonet 0/4/0
aps group acr 1
aps protect 1 10.7.7.7
end
```



Note To restore the system to its default condition, use the **no** form of the command.

Configuring Unidirectional APS for SAToP

Note When the **aps adm** command is not used, the LOS is detected on active port and the L-AIS is transmitted to the remote-end to force APS switchover. This is similar to bi-directional APS mode.

'When the **aps adm** command is used, the ports are in strict unidirectional mode. When the LOS is detected on active port, the L-AIS is suppressed and behaves in a strict uni-directional mode.

Ensure that the configuration is performed under the protected interface.

To configure unidirectional ACR (SONET Framing), use the following commands:

```
enable
configure terminal
controller sonet 0/5/0
clock source internal
aps group acr 1
aps working 1
aps unidirectional
exit
controller sonet 0/4/0
aps group acr 1
aps protect 1 10.7.7.7
aps revert 3
aps adm
end
```



Note To restore the system to its default condition, use the **no** form of the command.

Verifying ACR Configurations for SAToP

This section includes show commands for ACR: The following example shows the ACR groups that have been configured or deleted:

```
Router# show acr group

ACR Group Working I/f Protect I/f Currently Active Status
```

```
-----

1 SONET 4/1/0 SONET 3/1/0 SONET 4/1/0
```

The following example shows the configured working and protect CEM interfaces under the ACR controller:

```
Router# show acr group 1 detail cem
ACR Group      Working I/f      Protect I/f      Currently Active      Status
-----
CE1            CEM0/3/0         CEM0/12/1       CEM0/3/0

CEM CKT Details
Cktid  State on Working  State on Protect
1      Enable Success   Enable Success
```

The following example shows the configuration under the ACR controller:

```
Router##show running-config | sec ACR
controller SONET-ACR 1
framing sonet
!
sts-1 1
  mode vt-15
  vtg 1 vt 1 cem-group 1 cep
!
sts-1 2
!
sts-1 3
interface CEM-ACR1
no ip address
cem 1
!
```

The following example shows the loopback IP address for the router:

```
Router# show ip interface brief | i Loopback

Loopback0 22.22.22.22 YES NVRAM up up
```

The following example shows the CEM-ACR circuit status:

```
Router# show cem circuit

CEM Int. ID Ctrlr Admin Circuit AC
-----
CEM-ACR1 1 UP UP Active UP
CEM-ACR1 2 UP UP Active UP
CEM-ACR1 3 UP UP Active UP
CEM-ACR1 4 UP UP Active UP
CEM-ACR1 5 UP UP Active UP
CEM-ACR1 6 UP UP Active UP
CEM-ACR1 7 UP UP Active UP
CEM-ACR1 8 UP UP Active UP
```

The following example shows the CEM-ACR circuit details for CEM group 0 under the CEM-ACR interface:

```
Router# #show cem circuit interface cem-acr 1 1

CEM-ACR1, ID: 1, Line: UP, Admin: UP, Ckt: ACTIVE
Controller state: up, T1/E1 state: up
Idle Pattern: 0xFF, Idle CAS: 0x8
```

```

Dejitter: 6 (In use: 0)
Payload Size: 192
Framing: Unframed
CEM Defects Set
None

Signalling: No CAS
RTP: Configured, RTP-HDR Compression: Disabled

Ingress Pkts:      8186065          Dropped:          0
Egress Pkts:      8186065          Dropped:          0

CEM Counter Details
Input Errors:      0                Output Errors:     0
Pkts Missing:     0                Pkts Reordered:   0
Misorder Drops:   0                JitterBuf Underrun: 0
Error Sec:        0                Severly Errored Sec: 0
Unavailable Sec:  0                Failure Counts:    0
Pkts Malformed:  0                JitterBuf Overrun: 0
Generated Lbits:  0                Received Lbits:    0
Generated Rbits:  0                Received Rbits:    0

```

The following example shows the MPLS L2 transport vc details for the specified vc. In this case it is the vc with vc-id = 1001:

```

Router# sh mpls l2 vc 1 det
Local interface: CE1 up, line protocol up, SATOP T1 1 up
  Destination address: 2.2.2.2, VC ID: 1, VC status: up
  Output interface: Te0/8/0, imposed label stack {100}
  Preferred path: not configured
  Default path: active
  Next hop: 31.1.1.2
Create time: 02:48:15, last status change time: 02:47:26
  Last label FSM state change time: 02:47:26
Signaling protocol: LDP, peer 2.2.2.2:0 up
  Targeted Hello: 1.1.1.1(LDP Id) -> 2.2.2.2, LDP is UP
  Graceful restart: not configured and not enabled
  Non stop routing: configured and enabled
  Status TLV support (local/remote) : enabled/supported
  LDP route watch : enabled
  Label/status state machine : established, LruRru
  Last local dataplane status rcvd: No fault
  Last BFD dataplane status rcvd: Not sent
  Last BFD peer monitor status rcvd: No fault
  Last local AC circuit status rcvd: No fault
  Last local AC circuit status sent: No fault
  Last local PW i/f circ status rcvd: No fault
  Last local LDP TLV status sent: No status
  Last remote LDP TLV status rcvd: No fault
  Last remote LDP ADJ status rcvd: No fault
MPLS VC labels: local 16, remote 100
Group ID: local 38, remote 36
MTU: local 0, remote 0
Remote interface description:
Sequencing: receive disabled, send disabled
Control Word: On (configured: autosense)
SSO Descriptor: 2.2.2.2/1, local label: 16
Dataplane:
  SSM segment/switch IDs: 274581/4096 (used), PWID: 1
VC statistics:
  transit packet totals: receive 0, send 0
  transit byte totals: receive 0, send 0
  transit packet drops: receive 0, seq error 0, send 0

```

The following example shows the currently configured APS groups on the router:

```
Router# show aps

SONET 0/5/2 APS Group 25: protect channel 0 (Inactive) (HA)
Working channel 1 at 1.1.1.1 (Enabled) (HA)
bidirectional, non-revertive
PGP timers (extended for HA): hello time=1; hold time=10
hello fail revert time=120
Received K1K2: 0x00 0x05
No Request (Null)
Transmitted K1K2: 0x00 0x00
No Request (Null)
Remote APS configuration: (null)
SONET 0/0/2 APS Group 25: working channel 1 (Active) (HA)
Protect at 1.1.1.1
PGP timers (from protect): hello time=1; hold time=10
Remote APS configuration: (null)
```

Configuring APS for CESoPSN

This section describes the configuration of APS for CESoPSN.

Configuring CEM Group for APS CT3-T1 in CESoPSN

To configure CEM group in CT3 mode of STS-1 for CESoPSN, use the following commands:

```
enable
configure terminal
controller sonet-acr 200
sts-1 1
mode ct3
t1 1 cem-group 0 timeslots 1 - 2
end
```

To configure internal clock source for the working controller, use the following commands:

```
enable
configure terminal
controller sonet 0/3/6
sts-1 3
t1 1 clock source internal
t1 1 framing esf
end
```

To configure internal clock source for the protect controller, use the following commands:

```
enable
configure terminal
controller sonet 0/4/6
sts-1 3
vtg 1 t1 1 clock source internal
vtg 1 t1 1 framing esf
end
```

Configuring CEM Group for APS VT1.5-T1 in CESoPSN

To configure CEM group in VT 1.5 mode of STS-1 for CESoPSN, use the following commands:

```
enable
configure terminal
```

```

controller sonet-acr 200
sts-1 3
mode vt-15
vtg 1 t1 1 cem-group 37 timeslots 1 - 5
end

```

To configure internal clock source for the working controller, use the following commands:

```

enable
configure terminal
controller sonet 0/3/6
sts-1 3
vtg 1 t1 1 clock source internal
vtg 1 t1 1 framing esf
end

```

To configure internal clock source for the protect controller, use the following commands:

```

enable
configure terminal
controller sonet 0/4/6
sts-1 3
vtg 1 t1 1 clock source internal
vtg 1 t1 1 framing esf
end

```

Configuring VT 1.5-T1 Loopback for SAToP

To configure VT 1.5-T1 loopback for SAToP, use the following commands:

```

enable
configure terminal
controller sonet 0/5/0
rate oc3
no ais shut
alarm- report all
framing sonet
clock source internal
sts-1 1
clock source internal
mode vt-15
vtg 1 t1 1 loopback local
end

```

Configuring VT 1.5-T1 BERT on SONET for SAToP

To configure VT 1.5-T1 BERT on SONET for SAToP, use the following commands:

```

enable
configure terminal
controller sonet 0/5/0
rate oc3
no ais shut
alarm- report all
framing sonet
clock source internal
sts-1 1
clock source internal
mode vt-15
vtg 1 t1 1 bert pattern 2^11 interval 10
end

```

Configuring Path Overhead

This section describes the configuration of path overhead.

C2 Flag

To configure the C2 flag, use the following commands:

```
enable
configure terminal
controller sonet 0/5/0
sts-1 1
overhead c2 10
end
```

J1 Flag

To configure the J1 flag, use the following commands:

```
enable
configure terminal
controller sonet 0/5/0
sts-1 1
overhead j1 expected length
end
```

Configuring Path Threshold

To configure path threshold, use the following commands:

```
enable
configure terminal
controller sonet 0/5/0
sts-1 1
threshold b3-tca 3
end
```

Verification of SONET Configuration

The following sample output shows the verification of SONET configuration:

```
Router# show controllers sonet 0/3/3
SONET 0/3/3 is up.                    =====> this is the controller/port
status.
  Hardware is

  Port configured rate: OC3             =====> this is the rate the port is configured
  on it.
  Applique type is Channelized Sonet / SDH
  Clock Source is Line                  ==> the clocking config
Medium info:
  Type: Sonet, Line Coding: NRZ,
SECTION:
  LOS = 0                               =====> the section level alarm
  LOF = 0
counter (from last clear counters)

SONET/SDH Section Tables
  INTERVAL    CV    ES    SES    SEFS
05:50-05:58  0    0    0    0                    ==> PMON for the
port

LINE:
  AIS = 0                               =====> the line level
  RDI = 0                                alarm counter (from last clear counters)
  REI = 0
  BIP(B2) = 0
```

```

Active Defects: None
Detected Alarms: None
Asserted/Active Alarms: None           =====> present active
  alarms on the port.
Alarm reporting enabled for: SLOS SLOF SF B2-TCA
BER thresholds:  SF = 10e-3  SD = 10e-6       =====> ber thresholds
TCA thresholds:  B2 = 10e-6
Rx: S1S0 = 00
    K1 = 00,   K2 = 00           =====> k1k2 values
    J0 = 00
    RX S1 = 00
Tx: S1S0 = 00
    K1 = 00,   K2 = 00
    J0 = 00

```

High Order Path:

```

PATH 1:
Clock Source is internal                =====> path level clock

  AIS = 0          RDI = 0          REI = 0          BIP(B3) = 0          =====> path
layer alarms counter
  LOP = 0          PSE = 0          NSE = 0          NEWPTR = 0
  LOM = 0          PLM = 0          UNEQ = 0

```

```

Active Defects: None
Detected Alarms: None
Asserted/Active Alarms: None           =====> present alarms
  on the path.
Alarm reporting enabled for: PLOP LOM B3-TCA

TCA threshold:  B3 = 10e-6
Rx: C2 = 00           =====> rx and tx C2 byte..
Tx: C2 = 02
PATH TRACE BUFFER : UNSTABLE

```

```

  00 00 00 00 00 00 00 00 00 00 00 00 00 00 00 00  .....  =====> path trace of the
path
  00 00 00 00 00 00 00 00 00 00 00 00 00 00 00 00  .....
  00 00 00 00 00 00 00 00 00 00 00 00 00 00 00 00  .....
  00 00 00 00 00 00 00 00 00 00 00 00 00 00 00 00  .....

```

```

SONET Path Tables
INTERVAL      CV      ES      SES      UAS
05:58-05:58   0       0       0       0

```

```

PATH 2:
Clock Source is internal

  AIS = 0          RDI = 0          REI = 0          BIP(B3) = 0
  LOP = 0          PSE = 0          NSE = 0          NEWPTR = 0
  LOM = 0          PLM = 0          UNEQ = 0

```

```

Active Defects: None
Detected Alarms: None
Asserted/Active Alarms: None
Alarm reporting enabled for: PLOP LOM B3-TCA

```

```

TCA threshold:  B3 = 10e-6
Rx: C2 = 00
Tx: C2 = 00

```

```

PATH TRACE BUFFER : UNSTABLE

```



```
00 00 00 00 00 00 00 00 00 00 00 00 00 00 00 00 .....
00 00 00 00 00 00 00 00 00 00 00 00 00 00 00 00 .....
00 00 00 00 00 00 00 00 00 00 00 00 00 00 00 00 .....
00 00 00 00 00 00 00 00 00 00 00 00 00 00 00 00 .....
```

SONET/SDH Path Tables

INTERVAL	CV	ES	SES	UAS
05:58-05:58	0	0	0	0

OC3.STS1 0/3/3.1 is up. =====> present status of the path
Hardware is

Applique type is VT1.5 =====> mode of the path

STS-1 1, VTG 1, T1 1 (VT1.5 1/1/1) is down =====> status of the SPE (t1)

VT Receiver has no alarm.

Receiver is getting AIS.

=====> alarm of the SPE (t1)

Framing is unframed, Clock Source is Internal =====> framing of the T1, clock of the t1

Data in current interval (230 seconds elapsed):

Near End

0 Line Code Violations, 0 Path Code Violations
0 Slip Secs, 0 Fr Loss Secs, 0 Line Err Secs, 0 Degraded Mins
0 Errored Secs, 0 Bursty Err Secs, 0 Severely Err Secs, 0 Unavailable Secs
0 Path Failures, 0 SEF/AIS Secs

Far End

0 Line Code Violations, 0 Path Code Violations
0 Slip Secs, 0 Fr Loss Secs, 0 Line Err Secs, 0 Degraded Mins
0 Errored Secs, 0 Bursty Err Secs, 0 Severely Err Secs, 0 Unavailable Secs
0 Path Failures

Data in Interval 1:

Near End

0 Line Code Violations, 0 Path Code Violations
0 Slip Secs, 0 Fr Loss Secs, 14 Line Err Secs, 0 Degraded Mins
0 Errored Secs, 0 Bursty Err Secs, 0 Severely Err Secs, 15 Unavailable Secs
1 Path Failures, 0 SEF/AIS Secs

Far End Data

0 Line Code Violations, 0 Path Code Violations
0 Slip Secs, 4 Fr Loss Secs, 2 Line Err Secs, 0 Degraded Mins
4 Errored Secs, 0 Bursty Err Secs, 4 Severely Err Secs, 0 Unavailable Secs
0 Path Failures

Total Data (last 1 15 minute intervals):

Near End

0 Line Code Violations, 0 Path Code Violations,
0 Slip Secs, 0 Fr Loss Secs, 14 Line Err Secs, 0 Degraded Mins,
0 Errored Secs, 0 Bursty Err Secs, 0 Severely Err Secs, 15 Unavailable Secs
1 Path Failures, 0 SEF/AIS Secs

Far End

0 Line Code Violations, 0 Path Code Violations,
0 Slip Secs, 4 Fr Loss Secs, 2 Line Err Secs, 0 Degraded Mins,
4 Errored Secs, 0 Bursty Err Secs, 4 Severely Err Secs, 0 Unavailable Secs
0 Path Failures

STS-1 1, VTG 1, T1 2 (VT1.5 1/1/2) is down

VT Receiver has no alarm.

Receiver is getting AIS.

The following table shows each field and its description.

Table 11: Field Description

Field	Description
SONET 0/3/3 is up	Shows that the SONET controller is operating. The controller's state can be up, down, or administratively down.
Port configured rate: OC3	Shows the rate configured on the port.
SECTION: LOS = 0 LOF = 0 BIP = 0	Shows the section level alarm counters.
SONET Section Tables: INTERVAL CV ES SES SEFS 05:50-05:58 0 0 0 0	Shows the PMON for the port.
LINE: AIS = 0 RDI = 0 REI = 0 BIP(B2) = 0	Shows the line level alarm counters.
Asserted/Active Alarms: None	Shows the active alarms on the port.
BER thresholds: SF = 10e-3 SD = 10e-6	Shows BER thresholds.
K1 = 00, K2 = 00	Shows the K1 and K2 values.
PATH 1: Clock Source is internal	Shows the path level clock.
AIS = 0 RDI = 0 REI = 0 BIP(B3) = 0 LOP = 0 PSE = 0 NSE = 0 NEWPTR = 0 LOM = 0 PLM = 0 UNEQ = 0	Shows the path layer alarm counters.
Active Defects: None Detected Alarms: None Asserted/Active Alarms: None Alarm reporting enabled for: PLOP LOM B3-TCA	Shows the alarms on the path.
TCA threshold: B3 = 10e-6 Rx: C2 = 00 =====> rx and tx C2 byte.. Tx: C2 = 02 PATH TRACE BUFFER : UNSTABLE	shows the Rx and Tx C2 bytes.
00 00 00 00 00 00 00 00 00 00 00 00 00 00 00 00	Shows the path trace.
OC3.STS1 0/3/3.1 is up.	Shows the status of the path.
Applique type is VT1.5	Shows the mode of the path.
STS-1 1, VTG 1, T1 1 (VT1.5 1/1/1) is down	Shows the status of SPE (T1).

Field	Description
Receiver is getting AIS.	Shows the alarm of SPE (T1).
Framing is unframed, Clock Source is Internal	Shows the framing of T1 and clock of the T1.

Performance Monitoring Use Cases or Deployment Scenarios

To view the performance monitoring result that includes statistics or error count, use the **show controller sonet** command:

```

Router# show controller sonet 0/2/0
SONET 0/2/0 is up.
  Hardware is

  Port configured rate: OC3
  Applique type is Channelized Sonet
  Clock Source is Internal
Medium info:
  Type: Sonet, Line Coding: NRZ,
  Alarm Throttling: OFF
SECTION:
  LOS = 0          LOF = 0          BIP(B1) = 0

SONET Section Tables
  INTERVAL      CV      ES      SES  SEFS
  12:00-12:07   0       0       0    0
  11:45-12:00   15      1       0    0
Total of Data in Current and Previous Intervals
  11:45-12:07   15      1       0    0

LINE:
  AIS = 0          RDI = 0          REI = 0          BIP(B2) = 0
Active Defects: None
Detected Alarms: None
Asserted/Active Alarms: None
Alarm reporting enabled for: SLOS SLOF LAIS SF SD LRDI B1-TCA B2-TCA
BER thresholds: SF = 10e-3 SD = 10e-6
TCA thresholds: B1 = 10e-6 B2 = 10e-6
Rx: S1S0 = 00
   K1 = 00, K2 = 00
   J0 = 00

   RX S1 = 00

Tx: S1S0 = 00
   K1 = 00, K2 = 00
   J0 = 04

Tx J0 Length : 64
Tx J0 Trace :

  52 6F 75 74 65 72 20 20 20 20 20 20 20 20 20 20 20 20 20 20 Router
  20 20 20 20 20 20 20 20 20 20 20 20 20 20 20 20 20 20 20 20
  20 20 20 20 20 20 20 20 20 20 20 20 20 20 20 20 20 20 20 20
  20 20 20 20 20 20 20 20 20 20 20 20 20 20 20 20 00 00 ..

Expected J0 Length : 64
Expected J0 Trace :
```

```

52 6F 75 74 65 72 20 20 20 20 20 20 20 20 20 20 20 20 20 20 Router
20 20 20 20 20 20 20 20 20 20 20 20 20 20 20 20 20 20 20 20
20 20 20 20 20 20 20 20 20 20 20 20 20 20 20 20 20 20 20 20
20 20 20 20 20 20 20 20 20 20 20 20 20 20 20 20 20 20 00 00 ..

Rx J0 Length : 64
Rx J0 Trace :

01 01 01 01 01 01 01 01 01 01 01 01 01 01 01 01 01 01 01 01 .....
01 01 01 01 01 01 01 01 01 01 01 01 01 01 01 01 01 01 01 01 .....
01 01 01 01 01 01 01 01 01 01 01 01 01 01 01 01 01 01 01 01 .....
01 01 01 01 01 01 01 01 01 01 01 01 01 01 01 01 01 01 01 00 .....

SONET Line Tables
INTERVAL      CV    ES    SES    UAS    CVFE    ESFE    SESFE    UASFEE
12:00-12:07   0     0     0     0     0     0     0     0
11:45-12:00  48    1     0     0     53    1     0     0
Total of Data in Current and Previous Intervals
11:45-12:07  48    1     0     0     53    1     0     0

High Order Path:

PATH 1:
Clock Source is internal

AIS = 0          RDI = 0          REI = 41350871   BIP(B3) = 9
LOP = 0          PSE = 0          NSE = 0          NEWPTR = 0
LOM = 0          PLM = 0          UNEQ = 1

Active Defects: None
Detected Alarms: None
Asserted/Active Alarms: None
Alarm reporting enabled for: PAIS PRDI PUNEQ PLOP PPLM LOM B3-TCA

TCA threshold: B3 = 10e-6
Rx: C2 = 04
Tx: C2 = 04

Tx J1 Length : 64
Tx J1 Trace

52 6F 75 74 65 72 20 30 2F 32 2F 30 2E 31 00 00 Router 0/2/0.1..
00 00 00 00 00 00 00 00 00 00 00 00 00 00 00 00 .....
00 00 00 00 00 00 00 00 00 00 00 00 00 00 00 00 .....
00 00 00 00 00 00 00 00 00 00 00 00 00 00 00 00 .....

Expected J1 Length : 64
Expected J1 Trace

52 6F 75 74 65 72 20 30 2F 32 2F 30 2E 31 00 00 Router 0/2/0.1..
00 00 00 00 00 00 00 00 00 00 00 00 00 00 00 00 .....
00 00 00 00 00 00 00 00 00 00 00 00 00 00 00 00 .....
00 00 00 00 00 00 00 00 00 00 00 00 00 00 00 00 .....

PATH TRACE BUFFER : UNSTABLE

Rx J1 Length : 64
Rx J1 Trace

BB 43 45 5F 31 5F 31 20 30 2F 34 2F 33 2E 31 00 .CE_1_1 0/4/3.1.
00 00 00 00 00 00 00 00 00 00 00 00 00 00 00 .....
00 00 00 00 00 00 00 00 00 00 00 00 00 00 00 .....

```

00 00 00 00 00 00 00 00 00 00 00 00 00 00 00 00

SONET Path Tables

INTERVAL	CV	ES	SES	UAS	CVFE	ESFE	SESFE	UASFE
12:00-12:07	0	0	0	0	0	0	0	389
11:45-12:00	0	1	1	0	0	0	0	900
Total of Data in Current and Previous Intervals								
11:45-12:07	0	1	1	0	0	0	0	1289

PATH 2:

Clock Source is internal

AIS = 0 RDI = 0 REI = 0 BIP(B3) = 0
 LOP = 1 PSE = 0 NSE = 0 NEWPTR = 0
 LOM = 0 PLM = 0 UNEQ = 1

Active Defects: None

Detected Alarms: PLOP

Asserted/Active Alarms: PLOP

Alarm reporting enabled for: PAIS PRDI PUNEQ PLOP PPLM LOM B3-TCA

TCA threshold: B3 = 10e-6

Rx: C2 = 00

Tx: C2 = 04

Tx J1 Length : 64

Tx J1 Trace

52 6F 75 74 65 72 20 30 2F 32 2F 30 2E 32 00 00 Router 0/2/0.2..
 00 00 00 00 00 00 00 00 00 00 00 00 00 00 00 00
 00 00 00 00 00 00 00 00 00 00 00 00 00 00 00 00
 00 00 00 00 00 00 00 00 00 00 00 00 00 00 00 00

Expected J1 Length : 64

Expected J1 Trace

52 6F 75 74 65 72 20 30 2F 32 2F 30 2E 32 00 00 Router 0/2/0.2..
 00 00 00 00 00 00 00 00 00 00 00 00 00 00 00 00
 00 00 00 00 00 00 00 00 00 00 00 00 00 00 00 00
 00 00 00 00 00 00 00 00 00 00 00 00 00 00 00 00

PATH TRACE BUFFER : UNSTABLE

Rx J1 Length : 0

Rx J1 Trace

SONET Path Tables

INTERVAL	CV	ES	SES	UAS	CVFE	ESFE	SESFE	UASFE
12:00-12:07	0	0	0	389	0	0	0	0
11:45-12:00	0	0	0	900	0	0	0	0
Total of Data in Current and Previous Intervals								
11:45-12:07	0	0	0	1289	0	0	0	0

PATH 3:

Clock Source is internal

AIS = 0 RDI = 0 REI = 0 BIP(B3) = 0
 LOP = 1 PSE = 0 NSE = 0 NEWPTR = 0
 LOM = 0 PLM = 0 UNEQ = 1

Active Defects: None

Detected Alarms: PLOP LOM

Asserted/Active Alarms: PLOP

Alarm reporting enabled for: PAIS PRDI PUNEQ PLOP PPLM LOM B3-TCA

TCA threshold: B3 = 10e-6

Rx: C2 = 00

Tx: C2 = 02

Tx J1 Length : 64

Tx J1 Trace

```

52 6F 75 74 65 72 20 30 2F 32 2F 30 2E 33 00 00 Router 0/2/0.3..
00 00 00 00 00 00 00 00 00 00 00 00 00 00 00 00 .....
00 00 00 00 00 00 00 00 00 00 00 00 00 00 00 00 .....
00 00 00 00 00 00 00 00 00 00 00 00 00 00 00 00 .....

```

Expected J1 Length : 64

Expected J1 Trace

```

52 6F 75 74 65 72 20 30 2F 32 2F 30 2E 33 00 00 Router 0/2/0.3..
00 00 00 00 00 00 00 00 00 00 00 00 00 00 00 00 .....
00 00 00 00 00 00 00 00 00 00 00 00 00 00 00 00 .....
00 00 00 00 00 00 00 00 00 00 00 00 00 00 00 00 .....

```

PATH TRACE BUFFER : UNSTABLE

Rx J1 Length : 0

Rx J1 Trace

SONET Path Tables

INTERVAL	CV	ES	SES	UAS	CVFE	ESFE	SESFE	UASFE
12:00-12:07	0	0	0	389	0	0	0	0
11:45-12:00	0	0	0	894	0	0	0	0
Total of Data in Current and Previous Intervals								
11:45-12:07	0	0	0	1283	0	0	0	0

To view the performance monitoring results in a table format, use the **show controller sonet tabular** command:

Router# **show controllers sonet 0/2/0 tabular**

SONET 0/2/0 is down.

Hardware is

Port configured rate: OC3

Applique type is Channelized Sonet

Clock Source is Internal

Medium info:

Type: Sonet, Line Coding: NRZ,

Alarm Throttling: OFF

SECTION:

LOS = 0 LOF = 0

BIP(B1) = 0

SONET Section Tables

INTERVAL	CV	ES	SES	SEFS
12:00-12:07	0	0	0	0
11:45-12:00	15	1	0	0
Total of Data in Current and Previous Intervals				
11:45-12:07	15	1	0	0

LINE:

AIS = 0 RDI = 0

REI = 0

BIP(B2) = 0

Active Defects: None

Tx J1 Length : 64
Tx J1 Trace

```

52 6F 75 74 65 72 20 30 2F 32 2F 30 2E 32 00 00 Router 0/2/0.2..
00 00 00 00 00 00 00 00 00 00 00 00 00 00 00 00 .....
00 00 00 00 00 00 00 00 00 00 00 00 00 00 00 00 .....
00 00 00 00 00 00 00 00 00 00 00 00 00 00 00 00 .....

```

Expected J1 Length : 64
Expected J1 Trace

```

52 6F 75 74 65 72 20 30 2F 32 2F 30 2E 32 00 00 Router 0/2/0.2..
00 00 00 00 00 00 00 00 00 00 00 00 00 00 00 00 .....
00 00 00 00 00 00 00 00 00 00 00 00 00 00 00 00 .....
00 00 00 00 00 00 00 00 00 00 00 00 00 00 00 00 .....

```

PATH TRACE BUFFER : UNSTABLE

Rx J1 Length : 0
Rx J1 Trace

SONET Path Tables

INTERVAL	CV	ES	SES	UAS	CVFE	ESFE	SESFE	UASFE
12:00-12:07	0	0	0	409	0	0	0	0
11:45-12:00	0	0	0	900	0	0	0	0
Total of Data in Current and Previous Intervals								
11:45-12:07	0	0	0	1309	0	0	0	0

SONET 0/2/0.2 T3 is down.
Hardware is NCS4200-1T8S-10CS

Applique type is Channelized T3 to T1
Receiver is getting AIS.
MDL transmission is disabled

FEAC code received: No code is being received
Framing is C-BIT Parity, Cablelength is 224
BER thresholds: SF = 10e-3 SD = 10e-6
Clock Source is internal
Equipment customer loopback

Near End Data

INTERVAL	LCV	PCV	CCV	PES	PSES	SEFS	UAS	LES	CES	CSES	LSES	PFC	PAIS
12:00-12:07	0	0	0	0	0	0	419	0	0	0	0	0	0
0 0													
11:45-12:00	0	0	0	0	0	0	910	0	0	0	0	1	1
0 0													
Total	0	0	0	0	0	0	910	0	0	0	0	1	1
0 0													

Far End Data

INTERVAL	PES	PSES	PUAS	PFC	PCV	PSASC
12:00-12:07	0	0	0	0	0	0
11:45-12:00	0	0	0	0	0	0
Total	0	0	0	0	0	0

STS-1 2, T1 1 (CT3 2-1) is down
timeslots:

```

FDL per ANSI T1.403 and AT&T 54016 spec.
Receiver is getting AIS.
Framing is ESF, Clock Source is Internal
INTERVAL      LCV  PCV  CSS  SELS  LES  DM  ES  BES  SES  UAS  SS
12:00-12:07   0    0    0    0    0    0  0  0  0  419  0
11:45-12:00   0    0    0    0    0    0  0  0  0  900  0
Total          0    0    0    0    0    0  0  0  0  900  0
Far End Data
INTERVAL      LCV  PCV  CSS  SELS  LES  DM  ES  BES  SES  UAS
12:00-12:07   0    0    0    0    0    0  0  0  0  0    0
11:45-12:00   0    0    0    0    0    0  0  0  0  0    0
Total          0    0    0    0    0    0  0  0  0  0    0
    
```

```

STS-1 2, T1 2 (CT3 2-2) is down
timeslots:
    
```

```

Router# sh controller sonet 0/2/0.3/1/1
SONET 0/2/0 is up.
Path mode VT15
    
```

```

STS-1 3, VTG 1, VT 1 (VT1.5 3/1/1) is down
VT Receiver has LP-AIS.
    
```

```

cep is configured: FALSE cem_id (0)
fwd_alarm_ais :0 fwd_alarm_rai :0
Framing is ESF, Clock Source is Internal
BIP2-tca:6, BIP2-sf:3, BIP2-sd:6
Tx V5:1
Rx V5:7
Tx J2 Length=64
TX J2 Trace Buffer:
00 00 00 00 00 00 00 00 00 00 00 00 00 00 00 00 .....
00 00 00 00 00 00 00 00 00 00 00 00 00 00 00 00 .....
00 00 00 00 00 00 00 00 00 00 00 00 00 00 00 00 .....
00 00 00 00 00 00 00 00 00 00 00 00 00 00 00 00 .....
    
```

```

Expected J2 Length=64
Expected J2 Trace Buffer:
00 00 00 00 00 00 00 00 00 00 00 00 00 00 00 00 .....
00 00 00 00 00 00 00 00 00 00 00 00 00 00 00 00 .....
00 00 00 00 00 00 00 00 00 00 00 00 00 00 00 00 .....
00 00 00 00 00 00 00 00 00 00 00 00 00 00 00 00 .....
    
```

```

Rx J2 Length=16
RX J2 Trace Buffer:
CRC-7: 0x5F ERROR

5B F4 5E 94 E4 93 F0 18 F7 A7 7C 71 D5 C2 F2 00    [.^.....|q....
    
```

```

Data in curerent interval (420 seconds elapsed)
Near End
  0 CodeViolations, 0 ErrorSecs, 0 Severly Err Secs, 419 Unavailable Secs
Far End
  0 CodeViolations, 0 ErrorSecs, 0 Severly Err Secs, 0 Unavailable Secs
Data in Interval 1:
Near End
  0 CodeViolations, 0 ErrorSecs, 0 Severly Err Secs, 893 Unavailable Secs
Far End
  0 CodeViolations, 0 ErrorSecs, 0 Severly Err Secs, 0 Unavailable Secs
Total Data (last 1 fifteen minute intervals):
Near End
  0 CodeViolations, 0 ErrorSecs, 0 Severly Err Secs, 893 Unavailable Secs
Far End
  0 CodeViolations, 0 ErrorSecs, 0 Severly Err Secs, 0 Unavailable Secs
    
```

```

STS-1 3, VTG 1, T1 1 (VT1.5 3/1/1) is down
timeslots:
FDL per ANSI T1.403 and AT&T 54016 spec.
Receiver is getting AIS.
Framing is ESF, Clock Source is Internal
Data in current interval (430 seconds elapsed):
  Near End
    0 Line Code Violations, 0 Path Code Violations
    0 Slip Secs, 0 Fr Loss Secs, 0 Line Err Secs, 0 Degraded Mins
    0 Errored Secs, 0 Bursty Err Secs, 0 Severely Err Secs
    429 Unavailable Secs, 0 Stuffed Secs
  Far End
    0 Line Code Violations, 0 Path Code Violations
    0 Slip Secs, 0 Fr Loss Secs, 0 Line Err Secs, 0 Degraded Mins
    0 Errored Secs, 0 Bursty Err Secs, 0 Severely Err Secs
    0 Unavailable Secs
Data in Interval 1:
  Near End
    0 Line Code Violations, 0 Path Code Violations
    0 Slip Secs, 0 Fr Loss Secs, 0 Line Err Secs, 0 Degraded Mins
    0 Errored Secs, 0 Bursty Err Secs, 0 Severely Err Secs
    893 Unavailable Secs, 0 Stuffed Secs
  Far End
    0 Line Code Violations, 0 Path Code Violations
    0 Slip Secs, 0 Fr Loss Secs, 0 Line Err Secs, 0 Degraded Mins
    0 Errored Secs, 0 Bursty Err Secs, 0 Severely Err Secs
    0 Unavailable Secs
Total Data (last 1 15 minute intervals):
  Near End
    0 Line Code Violations,0 Path Code Violations,
    0 Slip Secs, 0 Fr Loss Secs, 0 Line Err Secs, 0 Degraded Mins,
    0 Errored Secs, 0 Bursty Err Secs, 0 Severely Err Secs
    893 Unavailable Secs, 0 Stuffed Secs
  Far End
    0 Line Code Violations,0 Path Code Violations
    0 Slip Secs, 0 Fr Loss Secs, 0 Line Err Secs, 0 Degraded Mins,
    0 Errored Secs, 0 Bursty Err Secs, 0 Severely Err Secs
    0 Unavailable Secs
Router# sh controller sonet 0/2/0.3/1/1 tabular
SONET 0/2/0 is up.
Path mode VT15

STS-1 3, VTG 1, VT 1 (VT1.5 3/1/1) is down
VT Receiver has LP-AIS.
cep is configured: FALSE cem_id (0)
fwd_alarm_ais :0    fwd_alarm_rai :0
Framing is ESF, Clock Source is Internal
BIP2-tca:6, BIP2-sf:3, BIP2-sd:6
Tx V5:1
Rx V5:7
Tx J2 Length=64
TX J2 Trace Buffer:
00 00 00 00 00 00 00 00 00 00 00 00 00 00 00 00 .....
00 00 00 00 00 00 00 00 00 00 00 00 00 00 00 00 .....
00 00 00 00 00 00 00 00 00 00 00 00 00 00 00 00 .....
00 00 00 00 00 00 00 00 00 00 00 00 00 00 00 00 .....

Expected J2 Length=64
Expected J2 Trace Buffer:
00 00 00 00 00 00 00 00 00 00 00 00 00 00 00 00 .....
00 00 00 00 00 00 00 00 00 00 00 00 00 00 00 00 .....
00 00 00 00 00 00 00 00 00 00 00 00 00 00 00 00 .....
00 00 00 00 00 00 00 00 00 00 00 00 00 00 00 00 .....

```

```
Rx J2 Length=16
RX J2 Trace Buffer:
CRC-7: 0x5F ERROR
```

```
5B F4 5E 94 E4 93 F0 18 F7 A7 7C 71 D5 C2 F2 00    [.^.....|q....
```

INTERVAL	CV	ES	SES	UAS	CVFE	ESFE	SESFE	UASFE
12:00-12:08	0	0	0	429	0	0	0	0
11:45-12:00	0	0	0	893	0	0	0	0
Total	0	0	0	893	0	0	0	0

```
STS-1 3, VTG 1, T1 1 (VT1.5 3/1/1) is down
timeslots:
FDL per ANSI T1.403 and AT&T 54016 spec.
Receiver is getting AIS.
```

```
Framing is ESF, Clock Source is Internal
```

INTERVAL	LCV	PCV	CSS	SELS	LES	DM	ES	BES	SES	UAS	SS
12:00-12:08	0	0	0	0	0	0	0	0	0	429	0
11:45-12:00	0	0	0	0	0	0	0	0	0	893	0
Total	0	0	0	0	0	0	0	0	0	893	0

```
Far End Data
```

INTERVAL	LCV	PCV	CSS	SELS	LES	DM	ES	BES	SES	UAS
12:00-12:08	0	0	0	0	0	0	0	0	0	0
11:45-12:00	0	0	0	0	0	0	0	0	0	0
Total	0	0	0	0	0	0	0	0	0	0

Table 12: Feature History Table

Feature Name	Release Information	Description
GR-820-CORE Performance Monitoring	Cisco IOS XE Bengaluru 17.5.1	The show controller tabular command enables you to view the performance monitoring details in tabular form as per GR-820-Core standards.

To view the performance monitoring details on the T1 interface, use the **show controller t1 tabular** command:

```
Router#show controllers t1 0/2/0 tabular
T1 0/6/0 is up
  Applique type is
  Cablelength is short 110
  No alarms detected.
  alarm-trigger is not set
  Soaking time: 3, Clearance time: 10
  Framing is ESF, Line Code is B8ZS, Clock Source is Line.
  BER thresholds: SF = 10e-3 SD = 10e-6
  Near End Data
  INTERVAL    CV-L    ES-L    CV-P    ES-P    SES-P    CSS-P    SAS-P    UAS-P    FC-P
  09:49-10:01 0        0        0        0        0        0        0        0        0
  Far End Data
  INTERVAL    ES-LFE  ES-PFE  SES-PFE  SEFS-PFE  CSS-PFE  UAS-PFE  FC-PFE
  09:49-10:01 0        0        0        0        0        0        0
```

To view the performance monitoring details on the T3 interface, use the **show controller t3 tabular** command:

```
Router#show controllers t3 0/2/0 tabular
T3 0/2/0 is up.
  Hardware is

  Applique type is Subrate T3
  No alarms detected.
```

MDL transmission is disabled

FEAC code received: No code is being received

Framing is C-BIT Parity, Line Code is B3ZS, Cablelength Short less than 225ft

BER thresholds: SF = 10e-3 SD = 10e-6

Clock Source is internal

Equipment customer loopback

Near End Data

INTERVAL	CV-L	ES-L	SES-L	LOSS-L	CVP-P	CVCP-P	ESP-P	ESCP-P	SESP-P	SESCP-P	SAS-P
19:03-19:11	0	0	0	0	0	0	0	0	0	0	0
0	0	0	0	0	0	0	0	0	0	0	0
18:48-19:03	0	0	0	0	0	0	0	0	0	0	0
0	0	0	0	0	0	0	0	0	0	0	0
Total	0	0	0	0	0	0	0	0	0	0	0
0	0	0	0	0	0	0	0	0	0	0	0

Far End Data

INTERVAL	CVCP-PFE	ESCP-PFE	SESCP-PFE	UASCP-PFE	FCCP-PFE	SASCP-PFE
19:03-19:11	0	0	0	0	0	0
18:48-19:03	0	0	0	0	0	0
Total	0	0	0	0	0	0

To view the performance monitoring details on the channelized T3-T1 interface, use the **show controller t3 tabular** command:

```
Router#show controllers t3 0/2/4 tabular
```

T3 0/2/4 is down.

Hardware is

Applique type is Channelized T3/T1

Receiver has loss of signal.

MDL transmission is disabled

FEAC code received: No code is being received

Framing is C-BIT Parity, Line Code is B3ZS, Cablelength Short less than 225ft

BER thresholds: SF = 10e-3 SD = 10e-6

Clock Source is internal

Equipment customer loopback

Near End Data

INTERVAL	CV-L	ES-L	SES-L	LOSS-L	CVP-P	CVCP-P	ESP-P	ESCP-P	SESP-P	SESCP-P	SAS-P
19:02-19:09	0	459	459	459	0	0	0	0	0	0	0
0	1	459	459	0	0	0	0	0	0	0	0

Far End Data

INTERVAL	CVCP-PFE	ESCP-PFE	SESCP-PFE	UASCP-PFE	FCCP-PFE	SASCP-PFE
19:02-19:09	0	0	0	0	0	0

T3 0/2/4.1 T1 is down

timeslots:

FDL per AT&T 54016 spec.

Receiver is getting AIS.

Framing is ESF, Clock Source is Internal

Near End Data

INTERVAL	CV-L	ES-L	CV-P	ES-P	SES-P	CSS-P	SAS-P	UAS-P	FC-P
19:02-19:09	0	0	0	0	0	0	0	0	1

Far End Data

INTERVAL	ES-LFE	ES-PFE	SES-PFE	SEFS-PFE	CSS-PFE	UAS-PFE	FC-PFE
19:02-19:09	0	0	0	0	0	0	0

To view the performance monitoring details on SONET, use the **show controller sonet tabular** command:

```
Router#show controllers sonet 0/9/7 tabular
```

SONET 0/9/7 is up.

Hardware is

```

10:01-10:23      0      0      0      0      0      0      0      0      0

APS
BERSF = 0          BERSD = 0
Active Alarms: None

PATH 1:
Clock Source is internal

AIS = 0          RDI = 0          REI = 0          BIP(B3) = 0
LOM = 0          PLM = 0          UNEQ = 0         LOP = 0

Active Defects: None
Detected Alarms: None
Asserted/Active Alarms: None
Alarm reporting enabled for: PAIS PRDI PUNEQ PLOP PPLM LOM B3-SF B3-SD B3-TCA

BER threshold: SF = 10e-3 SD = 10e-6
TCA threshold: B3 = 10e-6
Rx: C2 = 04
Tx: C2 = 04

Tx J1 Length : 64
Tx J1 Trace

50 45 32 20 30 2F 39 2F 37 2E 31 00 00 00 00 00      PE2 0/9/7.1.....
00 00 00 00 00 00 00 00 00 00 00 00 00 00 00 00      .....
00 00 00 00 00 00 00 00 00 00 00 00 00 00 00 00      .....
00 00 00 00 00 00 00 00 00 00 00 00 00 00 00 00      .....

Expected J1 Length : 64
Expected J1 Trace

50 45 32 20 30 2F 39 2F 37 2E 31 00 00 00 00 00      PE2 0/9/7.1.....
00 00 00 00 00 00 00 00 00 00 00 00 00 00 00 00      .....
00 00 00 00 00 00 00 00 00 00 00 00 00 00 00 00      .....
00 00 00 00 00 00 00 00 00 00 00 00 00 00 00 00      .....

Rx J1 Length : 64
Rx J1 Trace

50 45 32 20 30 2F 37 2F 31 39 2E 31 00 00 00 00      PE2 0/7/19.1....
00 00 00 00 00 00 00 00 00 00 00 00 00 00 00 00      .....
00 00 00 00 00 00 00 00 00 00 00 00 00 00 00 00      .....
00 00 00 00 00 00 00 00 00 00 00 00 00 00 00 00      .....

SONET Path Tables
INTERVAL      CV-P  ES-P  SES-P  UAS-P  CV-PFE  ES-PFE  SES-PFE  UAS-PFE
10:16-10:23   0     0     0     0     0     0     0     0     0
10:01-10:16   0     0     0     0     0     0     0     0     0
Total of Data in Current and Previous Intervals
10:01-10:23   0     0     0     0     0     0     0     0     0

PATH 2:
Clock Source is internal

AIS = 0          RDI = 0          REI = 0          BIP(B3) = 0
LOM = 0          PLM = 0          UNEQ = 0         LOP = 0

Active Defects: None
Detected Alarms: None
Asserted/Active Alarms: None
Alarm reporting enabled for: PAIS PRDI PUNEQ PLOP PPLM LOM B3-SF B3-SD B3-TCA

```

BER threshold: SF = 10e-3 SD = 10e-6
 TCA threshold: B3 = 10e-6
 Rx: C2 = 00
 Tx: C2 = 00

Tx J1 Length : 64
 Tx J1 Trace

```

50 45 32 20 30 2F 39 2F 37 2E 32 00 00 00 00 00      PE2 0/9/7.2.....
00 00 00 00 00 00 00 00 00 00 00 00 00 00 00      .....
00 00 00 00 00 00 00 00 00 00 00 00 00 00 00      .....
00 00 00 00 00 00 00 00 00 00 00 00 00 00 00      .....
    
```

Expected J1 Length : 64
 Expected J1 Trace

```

50 45 32 20 30 2F 39 2F 37 2E 32 00 00 00 00 00      PE2 0/9/7.2.....
00 00 00 00 00 00 00 00 00 00 00 00 00 00 00      .....
00 00 00 00 00 00 00 00 00 00 00 00 00 00 00      .....
00 00 00 00 00 00 00 00 00 00 00 00 00 00 00      .....
    
```

Rx J1 Length : 0
 Rx J1 Trace

SONET Path Tables

INTERVAL	CV-P	ES-P	SES-P	UAS-P	CV-PFE	ES-PFE	SES-PFE	UAS-PFE
10:23-10:23	0	0	0	0	0	0	0	0

PATH 3:
 Clock Source is internal

```

AIS = 0          RDI = 0          REI = 0          BIP(B3) = 0
LOM = 0         PLM = 0         UNEQ = 0        LOP = 0
    
```

Active Defects: None
 Detected Alarms: None
 Asserted/Active Alarms: None
 Alarm reporting enabled for: PAIS PRDI PUNEQ PLOP PPLM LOM B3-SF B3-SD B3-TCA

BER threshold: SF = 10e-3 SD = 10e-6
 TCA threshold: B3 = 10e-6
 Rx: C2 = 00
 Tx: C2 = 00

Tx J1 Length : 64
 Tx J1 Trace

```

50 45 32 20 30 2F 39 2F 37 2E 33 00 00 00 00 00      PE2 0/9/7.3.....
00 00 00 00 00 00 00 00 00 00 00 00 00 00 00      .....
00 00 00 00 00 00 00 00 00 00 00 00 00 00 00      .....
00 00 00 00 00 00 00 00 00 00 00 00 00 00 00      .....
    
```

Expected J1 Length : 64
 Expected J1 Trace

```

50 45 32 20 30 2F 39 2F 37 2E 33 00 00 00 00 00      PE2 0/9/7.3.....
00 00 00 00 00 00 00 00 00 00 00 00 00 00 00      .....
00 00 00 00 00 00 00 00 00 00 00 00 00 00 00      .....
00 00 00 00 00 00 00 00 00 00 00 00 00 00 00      .....
    
```

Rx J1 Length : 0
 Rx J1 Trace

```

SONET Path Tables
  INTERVAL      CV-P  ES-P  SES-P  UAS-P  CV-PFE  ES-PFE  SES-PFE  UAS-PFE
  10:23-10:23   0     0     0     0     0       0       0       0       0

SONET 0/9/7.1 T3 is up.
  Hardware is NCS4200-1T8S-20CS

  Applique type is T3
  No alarms detected.
  MDL transmission is disabled

  FEAC code received: No code is being received
  Framing is C-BIT Parity, Cablelength is 224
  BER thresholds: SF = 10e-3 SD = 10e-6
  Clock Source is internal
  Equipment customer loopback
  Near End Data
  INTERVAL      CV-L  ES-L  SES-L  LOSS-L  CVP-P  CVCP-P  ESP-P  ESCP-P  SESP-P  SESP-P  SAS-P
  AISS-P  FC-P  UASP-P  UASCP-P
  10:16-10:23   0     0     0     0     0     0     0     0     0     0     0
  0     0     0     0
  10:01-10:16   0     0     0     0     0     0     0     0     0     0     0
  0     0     0     0
  Total         0     0     0     0     0     0     0     0     0     0     0
  0     0     0     0
  Far End Data
  INTERVAL      CVCP-PFE  ESCP-PFE  SESP-PFE  UASCP-PFE  FCCP-PFE  SASCP-PFE
  10:16-10:23   0         0         0         0         0         0
  10:01-10:16   0         0         0         0         0         0
  Total         0         0         0         0         0         0
PE2#

```

Configuring Port Rate and Verifying Pluggables

A comprehensive range of pluggable optical modules is available. For more information, see .

Configuring ONS Pluggables

To configure ONS Pluggables, use the following commands:

```

enable
configure terminal
controller mediatype 0/12/0
mode sonet
exit
controller sonet 0/12/0
rate oc3

```

Verifying the Pluggables

Before you configure the pluggables, use the following commands to verify the supported pluggables:

show hw-module subslot <slot/bay> transceiver <port> status:

```

The Transceiver in slot 0 subslot 7 port 4 is enabled.
Module temperature = +46.636 C

```



```

Transceiver Tx supply voltage      = 3291.5 mVolts
Transceiver Tx bias current        = 17264 uAmps
Transceiver Tx power                = -2.9 dBm
Transceiver Rx optical power       = -7.4 dBm

```



Note The `show hw-module subslot <slot/bay> transceiver <port> status` displays as **Enabled** if the pluggables are supported and the command displays as **Disabled** if the pluggables are not supported.

show hw-module subslot <slot/bay> transceiver <port> idprom:

```

show hw-module subslot 0/7 transceiver 6 idprom detail
IDPROM for transceiver SPA-1T8S-10CS_7/6:
  Description                      = SFP or SFP+ optics (type 3)
  Transceiver Type:                 = ONS SE Z1 (406)
  Product Identifier (PID)          = ONS-SE-Z1
  Vendor Revision                   = A
  Serial Number (SN)                = FNS19251NPM
  Vendor Name                       = CISCO-FINISAR
  Vendor OUI (IEEE company ID)     = 00.90.65 (36965)
  CLEI code                         = WMOTCZPAAA
  Cisco part number                 = 10-1971-04
  Device State                      = Enabled.
  Date code (yy/mm/dd)             = 15/06/19
  Connector type                    = LC.
  Encoding                          = 8B10B
                                     NRZ
                                     Manchester
  Nominal bitrate                    = OC48/STM16 (2500 Mbits/s)
  Minimum bit rate as % of nominal bit rate = not specified
  Maximum bit rate as % of nominal bit rate = not specified
  The transceiver type is 406
  Link reach for 9u fiber (km)      = IR-1(15km) (15)
                                     SR(2km) (0)
                                     IR-1(15km) (0)
                                     IR-2(40km) (0)
                                     LR-1(40km) (0)
                                     LR-2(80km) (0)
                                     LR-3(80km) (0)
                                     DX(40KM) (0)
                                     HX(40km) (0)
                                     ZX(80km) (0)
                                     VX(100km) (0)
                                     1xFC, 2xFC-SM(10km) (0)
                                     ESCON-SM(20km) (0)
  Link reach for 62.5u fiber (m)   = SR(2km) (0)
                                     IR-1(15km) (0)
                                     IR-2(40km) (0)
                                     LR-1(40km) (0)
                                     LR-2(80km) (0)
                                     LR-3(80km) (0)
                                     DX(40KM) (0)
                                     HX(40km) (0)
                                     ZX(80km) (0)
                                     VX(100km) (0)
                                     1xFC, 2xFC-SM(10km) (0)
                                     ESCON-SM(20km) (0)
  Nominal laser wavelength          = 1310 nm.
  DWDM wavelength fraction          = 1310.0 nm.
  Supported options                  = Tx disable
                                     Tx fault signal
                                     Loss of signal (standard implementation)

```

```

Supported enhanced options           = Alarms for monitored parameters
                                     Software Rx LOS monitoring
Diagnostic monitoring                 = Digital diagnostics supported
                                     Diagnostics are externally calibrated
                                     Rx power measured is "Average power"

Transceiver temperature operating range = -40 C to 85 C (industrial)
Minimum operating temperature         = -40 C
Maximum operating temperature         = 85 C
High temperature alarm threshold      = +90.000 C
High temperature warning threshold    = +85.000 C
Low temperature warning threshold     = -40.000 C
Low temperature alarm threshold       = -45.000 C
High voltage alarm threshold          = 3630.0 mVolts
High voltage warning threshold        = 3470.0 mVolts
Low voltage warning threshold         = 3140.0 mVolts
Low voltage alarm threshold           = 2971.2 mVolts
High laser bias current alarm threshold = 85.000 mAmps
High laser bias current warning threshold = 65.000 mAmps
Low laser bias current warning threshold = 4.000 mAmps
Low laser bias current alarm threshold = 2.000 mAmps
High transmit power alarm threshold   = 4.0 dBm
High transmit power warning threshold = 2.0 dBm
Low transmit power warning threshold  = -7.0 dBm
Low transmit power alarm threshold    = -9.0 dBm
High receive power alarm threshold    = 1.0 dBm
Low receive power alarm threshold     = -26.0 dBm
High receive power warning threshold  = -1.0 dBm
Low receive power warning threshold   = -24.9 dBm
External Calibration: bias current slope = 1.000
External Calibration: bias current offset = 0

```

show hw-module subslot <slot/bay> transceiver <port> idprom brief:

```

sh hw-module subslot 0/7 transceiver 6 idprom brief
IDPROM for transceiver SPA-1T8S-10CS_7/6:
  Description                       = SFP or SFP+ optics (type 3)
  Transceiver Type:                  = ONS SE Z1 (406)
  Product Identifier (PID)           = ONS-SE-Z1
  Vendor Revision                     = A
  Serial Number (SN)                 = FNS19251N00
  Vendor Name                         = CISCO-FINISAR
  Vendor OUI (IEEE company ID)       = 00.90.65 (36965)
  CLEI code                           = WMOTCZPAAA
  Cisco part number                   = 10-1971-04
  Device State                        = Enabled.
  Date code (yy/mm/dd)               = 15/06/19
  Connector type                      = LC.
  Encoding                            = 8B10B
                                     NRZ
                                     Manchester
  Nominal bitrate                     = OC48/STM16 (2500 Mbits/s)
  Minimum bit rate as % of nominal bit rate = not specified
  Maximum bit rate as % of nominal bit rate = not specified

```

Configuring BERT in Sonet for CESoPSN

Bit-Error Rate Testing (BERT) is used for analyzing quality and for problem resolution of digital transmission equipment. BERT tests the quality of an interface by directly comparing a pseudorandom or repetitive test pattern with an identical locally-generated test pattern.

BERT is supported in the following two directions:

- Line—Supports BERT in TDM direction.
- System—Supports BERT in PSN direction.

BERT is supported in following controllers:

- T1—NxDS0, DS1
- T3—NxDS0, DS1 (channelised), clear channel DS3.
- OCx—NxDS0, DS1 (channelised), DS3 (channelised), clear channel DS3, STS1, STS-nc, VT-1.5, VT1.5 T1

Configuring VT1.5-T1 BERT for CESoPSN

To configure VT 1.5-T1 BERT, use the following commands:

```
enable
configure terminal
controller sonet 0/5/0
rate oc3
no ais shut
alarm- report all
clock source internal
sts-1 1
clock source internal
mode vt-15
vtg 1 t1 1 bert timeslots 1 pattern 2^11 interval 10
end
```

Verifying VT1.5-T1 BERT Configuration for CESoPSN

Use **show controller sonet** command to verify BERT configuration in mode VT 1.5:

```
Router# show controller sonet 0/5/0.2/2/3 | sec BERT

BERT running on timeslots 1,2,3,4,5,6,7,8,
BERT test result (running)
  Test Pattern : 2^11, Status : Sync, Sync Detected : 1
  Interval : 1 minute(s), Time Remain : 00:00:43
  Bit Errors (since BERT started): 0 bits,
  Bits Received (since BERT started): 8 Mbits
  Bit Errors (since last sync): 0 bits
  Bits Received (since last sync): 8 Mbits
  Direction   : Line
```

Configuring CT3-T1 mode BERT for CESoPSN

To configure T1 CT3 mode BERT, use the following commands:

```
controller mediatype 0/5/0
mode sonet
controller sonet 0/5/0
rate oc3
```

```
sts-1 1
mode ct3
t1 4 bert timeslots 1 pattern 2^15 interval 1 direction
```

Verifying CT3-T1 mode BERT for CEsOPSN

Use **show controller sonet** command to verify BERT configuration in mode CT3:

```
Router# show controller sonet 0/5/0.1/4 | sec BERT
BERT running on timeslots 1,
BERT test result (running)
  Test Pattern : 2^15, Status : Sync, Sync Detected : 1
  Interval : 1 minute(s), Time Remain : 00:00:43
  Bit Errors (since BERT started): 0 bits,
  Bits Received (since BERT started): 1 Mbits
  Bit Errors (since last sync): 0 bits
  Bits Received (since last sync): 1 Mbits
  Direction : Line
```

Loopback Remote on T1 and T3 Interfaces

The remote loopback configuration attempts to put the far-end T1 or T3 into a loopback.

The remote loopback setting loops back the far-end at line or payload, using IBOC (inband bit-orientated CDE) or the ESF loopback codes to communicate the request to the far-end.

Restrictions for Loopback Remote

- E1 and E3 loopback remote are not supported until Cisco IOS XE Fuji 16.9.4 release. Starting from Cisco IOS XE Fuji 16.9.5 release, E1 and E3 loopback remote are supported.
- IBOC loopcode configuration is not supported when CEsOP or SATOP (framed or unframed) is configured.
- ESF loopcode configuration is not supported when SAToP is configured.

Configuring Loopback Remote in Sonet

To set T1 loopback remote iboc fac1/fac2/csu for OCX sonet, perform the following tasks in global configuration mode:

```
enable
configure terminal
controller sonet 0/0/1
mode ct3
t1 1 loopback remote iboc {fac1 | fac2 | csu}
mode vt-15
vtg 1 t1 1 loopback remote iboc {fac1 | fac2 | csu}
```

To set T1 loopback remote iboc esf line csu/esf payload for OCX sonet, perform the following tasks in global configuration mode:

```
enable
configure terminal
```

```

controller sonet 0/0/1
mode ct3
t1 1 loopback remote iboc esf {line csu | payload}
mode vt-15
vtg 1 t1 1 loopback remote esf {line csu | payload}

```

To set T3 loopback remote line/payload for OCX in sonet, perform the following tasks in global configuration mode:

```

enable
configure terminal
controller sonet 0/0/1
mode t3
t3 loopback remote {line | payload}

```



Note `loopback remote esf line niu` is not supported.

Verifying the Loopback Remote Configuration

Use the following command to check the T1 loopback remote configuration:

```

router# show run | sec 0/0/1
controller SONET 0/0/1
rate OC3
no ais-shut
alarm-report all
clock source internal
!
sts-1 1
!
sts-1 2
  clock source internal
  mode ct3
  t3 framing c-bit
  t3 clock source internal
  t1 1 Loopback remote iboc fac1
  t1 1 framing SF

```

Use the following command to verify the T1 loopback remote configuration:

```

Router(config-ctrlr-sts1)# show controller sonet 0/0/1 | b STS-1 2, T1 1
STS-1 2, T1 1 (CT3 2-1) is up
timeslots:
Configured for NIU FAC1 Line Loopback with IBOC
Currently in Inband Remotely Line Looped
Receiver has no alarms.
Framing is SF, Clock Source is Internal

```

Use the following command to check T3 loopback remote configuration:

```

Router# show run | sec 0/0/1
controller SONET 0/0/1
rate OC3
no ais-shut
alarm-report all
clock source internal

```

```

!
sts-1 1
!
sts-1 2
!
sts-1 3
  clock source internal
  mode t3
  t3 framing c-bit
  t3 loop remote line
  t3 clock source internal

```

Use the following command to verify T3 loopback remote configuration:

```

Router(config-ctrlr-sts1)# do show controller sonet 0/0/1 | b Path 3
OC3.STS1 0/0/1 Path 3 is up. (Configured for Remotely Looped)
  Currently in Remotely Line Looped
  Hardware is NCS4200-1T8S-10CS

  Applique type is T3
  Receiver has no alarms.
  MDL transmission is disabled

```

Clock Recovery System in CESoPSN

The Clock Recovery System is able to recover the service clock using two methods, the Adaptive Clock Recovery and Differential Clock Recovery.

Adaptive Clock Recovery in CESoPSN

When emulating TDM over PSNs, the physical layer clock is sometimes not available to both ends. Adaptive Clock Recovery (ACR) is a technique where the clock from the TDM domain is mapped through the packet domain. The sending Inter Working Function (IWF) processes outgoing packets with an internal free-running clock, and the receiving IWF creates a clock based on packet arrival. The service clock frequency is adjusted depending on fill level of the jitter buffer.

- When sending TDM digital signal over PSN, the TDM data is inserted into packets in the primary IWF and sent to the desired destination (subordinate IWF).
- The rate at which the packets are transmitted to the PSN is constant. Due to the nature of the PSN, the packets might arrive to the destination in bursts and with varying rate.
- The long-term average of this rate is equal to the insertion rate at the primary IWF. Moreover, the packets in the PSN might switch their order and even be lost.
- The IWF at the far end of the PSN (subordinate IWF) recovers the service clock (E1/T1) used by the primary IWF.
- The recovered clock is used by the subordinate IWF for the transmission of the data back into the TDM lines.
- The primary IWF aggregates the TDM data and creates the PWE packets; these packets are transmitted to the PSN.

- The packets are received by the subordinate IWF and stored in a jitter buffer designed to absorb the packet delay variation (PDV).
- The packets are extracted from the jitter buffer and the clock recovery algorithm updates the service clock based on the timing information available.

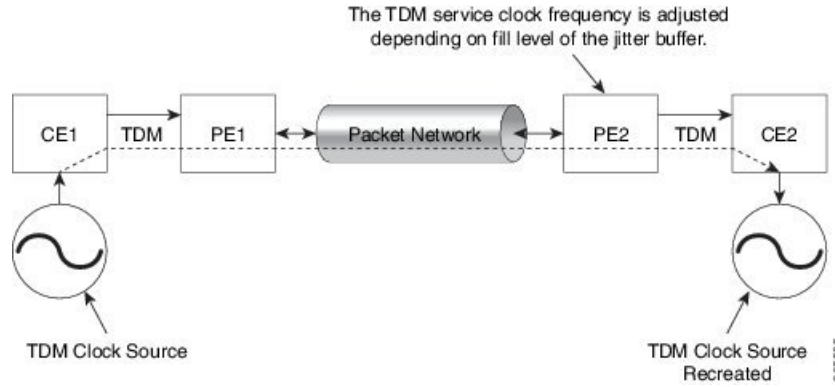

Differential Clock Recovery in CESoPSN

DCR (Differential Clock Recovery) is another technique used for Circuit Emulation (CEM) to recover clocks based on the difference between PE clocks. The clock from the TDM domain is mapped through the packet domain. It differs from ACR in that a PRC traceable clock is used at each end. Differential timing messages are used to tune the TDM clock frequency from the sending end to the receiving end. Both ends have a source traceable reference. Because of this, the recovered clock is not affected by PDV when using DCR.

In contrast with DCR, a PRC traceable clock source is available at each end. ACR is used when a traceable source is not available at both ends of the PSN link.

The recreated service clock accuracy is dependent on the accuracy between the sending and receiving PRC frequencies.

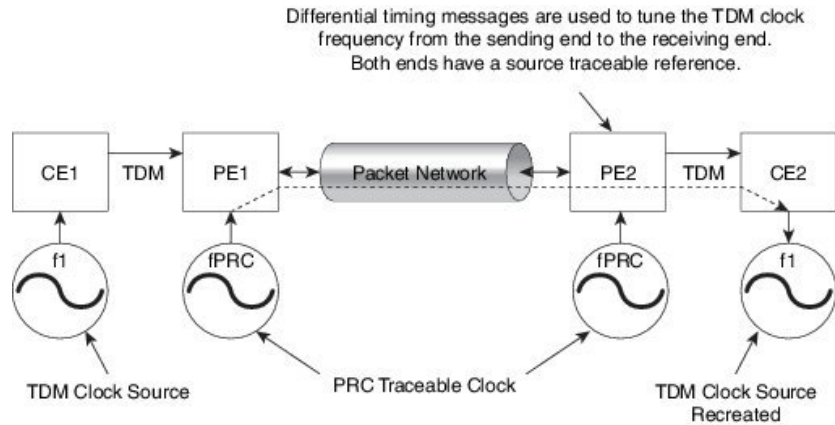

Benefits of Clock Recovery

- Customer-edge devices (CEs) can have different clock from that of the Provide-edge devices (PEs).
- In CESoPSN, a slave clock is supported for clock redundancy.

Scaling Information

IM Card	Pseudowires Supported (Number of Clocks Derived)
48-Port T1/E1 CEM Interface Module	48

Prerequisites for Clock Recovery

- The clock of interface modules must be used as service clock.
- CEM must be configured before configuring the global clock recovery.
- RTP must be enabled for DCR in CEM, as the differential clock information is transferred in the RTP header.

Restrictions for Clock Recovery

- The reference clock source is used and locked to a single clock.
- The clock ID should be unique for a particular interface module for ACR or DCR configuration.
- When CEM group is configured, dynamic change in clock source is not allowed.
- ACR clock configuration under each controller should be performed before configuring CEM group.
- When ACR or DCR is configured and loopback network is applied on the same PDH (T1/E1), then the ACR or DCR mode configuration is removed to enable the loopback. The ACR or DCR should be configured again after the loopback maintenance activity.

Scale Restrictions

- For the Cisco IOS XE Amsterdam 17.3.x release, a maximum of **5376** ACR and DCR session scale is supported on the Cisco 1-port OC-192 Interface module or 8-port Low Rate Interface Module (8-port SFP GE and 1-port 10GE IM with CEM, 10G). For releases before the Cisco IOS XE Amsterdam 17.3.1 release, only 2000 session are supported.

Configuring ACR in VT 1.5-T1 mode for CESoPSN

To configure the CEM group in the SONET controller:

```
configure terminal
controller sonet <bay>/<slot>/<port>
rate OC3
sts-1 <num>
mode vt-15
vtg <vtg_no> t1 <t1_num> clock source recovered <clock-id>
vtg <vtg_no> t1 <t1_num> cem-group <cem-group-no> timeslots <1-24>
```

To configure the CEM interface for CESoPSN:

```
interface cem <bay>/<slot>/<port>
```



```
cem <cem-group-no>
```

To configure recovered clock for CESoPSN:

```
recovered-clock <bay> <slot>
clock recovered <clock-id> adaptive cem <port-no> <cem-group-no> priority <priority no>
```

Verifying ACR in VT 1.5-T1 mode for CESoPSN

Use the **show recovered-clock** command to verify the ACR for CEM groups 58 and 61 configured in VT 1.5 mode on T1 interface:

```
Router#show recovered clock
Recovered clock status for subslot 0/5
-----
Clock      Type      Mode      CEM      Status    Frequency Offset (ppb)  Circuit-No
          Priority
19         OCx-T1    ADAPTIVE   58      ACQUIRING n/a              0/2/1/1
(Port/path/vtg/t1)      2
20         OCx-T1    ADAPTIVE   61      ACQUIRING n/a              0/2/1/2
(Port/path/vtg/t1)      2
```

Configuring DCR in VT 1.5-T1 mode for CESoPSN

To configure the CEM group in the SONET controller:

```
configure terminal
controller sonet <bay>/<slot>/<port>
rate OC3
sts-1 <num>
mode vt-15
vtg <vtg_no> t1 <t1_num> clock source recovered <clock-id>
vtg <vtg_no> t1 <t1_num> cem-group <cem-group-no> timeslots <1-24>
```

To configure the CEM interface for CESoPSN:

```
interface cem <bay>/<slot>/<port>
cem <cem-group-no>
rtp-present
```

To configure recovered clock for CESoPSN:

```
recovered-clock <bay> <slot>
clock recovered <clock-id> differential cem <port-no> <cem-group-no> priority <priority no>
```

Verifying DCR in VT 1.5-T1 mode for CESoPSN

Use the **show recovered-clock** command to verify the DCR for CEM groups 59 and 60 configured in VT 1.5 mode on T1 interface:

```
Router#show recovered clock
Recovered clock status for subslot 0/5
-----
Clock      Type      Mode      CEM      Status      Frequency Offset (ppb)  Circuit-No
  Priority
11      OCx-T1  DIFFERENTIAL  59  ACQUIRING  n/a              0/2/1/1
  (Port/path/vtg/t1)  2
12      OCx-T1  DIFFERENTIAL  60  ACQUIRING  n/a              0/2/1/2
  (Port/path/vtg/t1)  2
```

Configuring ACR in CT3-T1 mode for CESoPSN

To configure the CEM group in the SONET controller:

```
configure terminal
controller sonet <bay>/<slot>/<port>
rate OC3
sts-1 <num>
mode ct3
t1 <t1_num> clock source recovered <clock-id>
t1 <t1_num> cem-group <cem-group-no> timeslots <1-24>
```

To configure recovered clock for CESoPSN:

```
recovered-clock <bay> <slot>
clock recovered <clock-id> adaptive cem <port-no> <cem-group-no> priority <priority no>
```

Verifying ACR in CT3-T1 mode for CESoPSN

Use the **show recovered-clock** command to verify the ACR for CEM groups 30 and 34 configured in CT3 mode on T1 interface:

```
Router#show recovered clock
Recovered clock status for subslot 0/5
-----
Clock      Type      Mode      CEM      Status      Frequency Offset (ppb)  Circuit-No
  Priority
17      OCx-T1  ADAPTIVE  30  ACQUIRING  n/a              0/1/3 (Port/t3/t1)
  2
18      OCx-T1  ADAPTIVE  34  ACQUIRED   n/a              0/1/4 (Port/t3/t1)
  2
```

Configuring DCR in CT3-T1 mode for CESoPSN

To configure the CEM group in the SONET controller:

```
configure terminal
controller sonet <bay>/<slot>/<port>
rate OC3
sts-1 <num>
mode ct3
t1 <t1_num> clock source recovered <clock-id>
```

```
t1 <t1_num> cem-group <cem-group-no> timeslots <1-24>
interface cem <bay>/<slot>/<port>
cem < cem-group-no>
rtp-present
```

To configure recovered clock for CESoPSN:

```
recovered-clock <bay> <slot>
clock recovered <clock-id> differential cem <port-no> <cem-group-no> priority <priority no>
```

Verifying DCR in CT3-T1 mode for CESoPSN

Use the **show recovered-clock** command to verify the DCR for CEM groups 31 and 32 configured in CT3 mode on T1 interface:

```
Router#show recovered clock
Recovered clock status for subslot 0/5
-----
Clock   Type      Mode          CEM  Status   Frequency Offset (ppb)  Circuit-No
  Priority
 17      OCx-T1    DIFFERENTIAL  31   ACQUIRING n/a          0/1/3 (Port/t3/t1)
 2
 18      OCx-T1    DIFFERENTIAL  32   ACQUIRED  n/a          0/1/4 (Port/t3/t1)
 2
```

Configuring Clocking for ACR and DCR on APS for CESoPSN

Configuring Clocking for ACR on APS CT3-T1 in CESoPSN

For clocking, you need to configure Sonet controllers with priority.

To configure clock source in CT3 mode of STS-1 for CESoPSN, use the following commands:

```
enable
configure terminal
controller mediatype 0/5/0
mode sonet
controller sonet 0/5/0
rate oc3
sts-1 1
mode ct3
t1 1 clock source recovered 1
end
```

To configure the recovered clock with priority 1, use the following commands:

```
enable
configure terminal
recovered-clock acr 200
clock recovered 1 adaptive cem 1 priority 1
end
```

To configure clock source in CT3 mode of STS-1 for CESoPSN, use the following commands:

```
enable
configure terminal
controller sonet 0/4/6
sts-1 1
mode ct3
t1 1 clock source recovered 1
end
```

To configure the recovered clock with priority 2, use the following commands:

```
enable
configure terminal
recovered-clock acr 200
clock recovered 1 adaptive cem 2 priority 2
end
```

Verifying Clocking for ACR on APS CT3-T1 in CESoPSN

Use the **show recovered-clock** command to verify the ACR on APS in CT3 mode for CESoPSN:

```
Router#show recovered clock
```

```
Recovered clock status for SONET-ACR 200
```

```
-----
```

Clock	Type	Mode	CEM	Status	Circuit-No	Working	Protect
Priority							
1	OCx-T1	ADAPTIVE	1	ACQUIRED	200/1/1(acr/t3/t1)	ACQUIRED	ACQUIRED
1							
4	OCx-T1	ADAPTIVE	38	ACQUIRING	200/3/1/1(acr/path/vtg/t1)	ACQUIRIN	ACQUIRING
1							

Configuring Clocking for DCR on APS CT3-T1 in CESoPSN

For clocking, you need to configure Sonet controllers with priority.

To configure clock source in CT3 mode of STS-1 for CESoPSN, use the following commands:

```
enable
configure terminal
controller mediatype 0/3/6
mode sonet
rate oc3
sts-1 1
mode ct3
t1 1 clock source recovered 1
end
```

To configure CEM interface, use the following commands:

```
interface cem <bay>/<slot>/<port>
cem <cem-group-no>
rtp-present
```

To configure the recovered clock with priority 1, use the following commands:

```
enable
```

```

configure terminal
recovered-clock dcr 200
clock recovered 1 differential cem 1 priority 1
end

```

To configure clock source in CT3 mode of STS-1 for CESoPSN, use the following commands:

```

enable
configure terminal
controller sonet 0/4/6
sts-1 1
mode ct3
t1 1 clock source recovered 1
end

```

To configure CEM interface, use the following commands:

```

interface cem <bay>/<slot>/<port>
cem <cem-group-no>
rtp-present

```

To configure the recovered clock with priority 2, use the following commands:

```

enable
configure terminal
recovered-clock dcr 200
clock recovered 1 differential cem 2 priority 2
end

```

Verifying Clocking for DCR on APS CT3-T1 in CESoPSN

Use the **show recovered-clock** command to verify the DCR on APS in CT3 mode for CESoPSN:

```
Router#show recovered clock
```

```
Recovered clock status for SONET-DCR 200
```

```

-----
Clock  Type      Mode      CEM  Status      Circuit-No      Working  Protect
  Priority
  2   OCx-T1  DIFFERENTIAL  13  ACQUIRED      200/2/1 (dcr/t3/t1)  ACQUIRED  ACQUIRED
  1
  5   OCx-T1  DIFFERENTIAL  44  ACQUIRING     200/4/1/1 (dcr/path/vtg/t1)  ACQUIRIN  ACQUIRING
  1

```

Configuring Clocking for ACR on APS VT 1.5-T1 in CESoPSN

For clocking, you need to configure Sonet controllers with priority.

To configure clock source in VT 1.5 mode of STS-1 for CESoPSN, use the following commands:

```

enable
configure terminal
controller sonet 0/3/6
sts-1 1
mode vt-15
vtg 1 t1 1 clock source recovered 4
end

```

To configure the recovered clock with priority 1, use the following commands:

```
enable
configure terminal
recovered-clock acr 200
clock recovered 4 adaptive cem 38 priority 1
end
```

To configure clock source in VT1.5 mode of STS-1 for CESoPSN, use the following commands:

```
enable
configure terminal
controller sonet 0/4/6
sts-1 1
mode vt-15
vtg 1 t1 1 clock source recovered 4
end
```

To configure the recovered clock with priority 2, use the following commands:

```
enable
configure terminal
recovered-clock acr 200
clock recovered 4 adaptive cem 39 priority 2
end
```

Verifying Clocking for ACR on APS VT 1.5-T1 in CESoPSN

Use the **show recovered-clock** command to verify the ACR on APS in VT 1.5 mode for CESoPSN:

```
Router#show recovered clock
Recovered clock status for SONET-ACR/SDH-ACR 200
-----
Clock   Type      Mode      CEM   Status      Circuit-No      Working      Protect
  Priority
 4      OCx-T1    ADAPTIVE   38   ACQUIRING  200/3/1/1(acr/path/vtg/t1) ACQUIRIN    ACQUIRING
 1
```

Configuring Clocking for DCR on APS VT 1.5-T1 in CESoPSN

For clocking, you need to configure Sonet controllers with priority.

To configure clock source in VT 1.5 mode of STS-1 for CESoPSN, use the following commands:

```
enable
configure terminal
controller sonet 0/3/6
sts-1 1
mode vt-15
vtg 1 t1 1 clock source recovered 4
end
```

To configure CEM interface, use the following commands:

```
interface cem <bay>/<slot>/<port>
cem <cem-group-no>
rtp-present
```

To configure the recovered clock with priority 1, use the following commands:

```
enable
configure terminal
recovered-clock acr 200
clock recovered 4 differential cem 38 priority 1
end
```

To configure clock source in VT1.5 mode of STS-1 for CESoPSN, use the following commands:

```
enable
configure terminal
controller sonet 0/4/6
sts-1 1
mode vt-15
vtg 1 t1 1 clock source recovered 4
end
```

To configure CEM interface, use the following commands:

```
interface cem <bay>/<slot>/<port>
cem <cem-group-no>
rtp-present
```

To configure the recovered clock with priority 2, use the following commands:

```
enable
configure terminal
recovered-clock acr 200
clock recovered 4 differential cem 39 priority 2
end
```

Verifying Clocking for DCR on APS VT 1.5-T1 in CESoPSN

Use the **show recovered-clock** command to verify the DCR on APS in VT 1.5 mode for CESoPSN:

```
Router#show recovered clock
Recovered clock status for SONET-ACR 200
-----
Clock   Type      Mode      CEM   Status      Circuit-No      Working      Protect
Priority
5       OCx-T1    DIFFERENTIAL  44   ACQUIRING  200/4/1/1(acr/path/vtg/t1) ACQUIRIN  ACQUIRING
1
```

Configuring VT-15 mode of STS-1 for Framed SAToP

To configure VT-15 mode of STS-1 for framed SAToP:

```
enable
configure terminal
controller mediatype 0/5/0
mode sonet
controller sonet 0/5/0
rate oc3
sts-1 1
mode vt-15
```

```
vtg 1 t1 1 cem-group 0 framed
end
```

Configuring DS1/T1 CT3 mode of STS-1 for Framed SAToP

To configure DS1 CT3 Framed SAToP mode:

```
enable
configure terminal
controller MediaType 0/5/0
mode sonet
controller sonet 0/5/0
rate oc3
sts-1 2
mode ct3
t3 framing c-bit
t1 1 cem-group 1 framed
end
```

Verifying SONET Configuration for Framed SAToP

To verify SONET configuration for Framed SAToP:

```
Router# show running configuration | sec 0/5/0
platform enable controller mediatype 0/5/0 oc3
controller mediatype 0/5/0
mode sonet
controller sonet 0/5/0
rate oc3
no ais-shut
alarm-report all
clock source internal
!
sts-1 1
clock source internal
mode vt-15
vtg 1 t1 1 cem-group 0 framed
!
sts-1 2
clock source internal
mode ct3
t3 framing c-bit
t3 clock source internal
t1 1 cem-group 1 framed
!
sts-1 3
clock source internal
mode ct3-e1
t3 framing c-bit
t3 clock source internal
e1 1 cem-group 2 framed
interface cem 0/5/0
no ip address
cem 0
!
cem 1
!
cem 2
```

#Router

Associated Commands

The following table shows the Associated Commands for SONET configuration:

Commands	Links
ais-shut	http://www.cisco.com/c/en/us/td/docs/ios-xml/ios/interface/command/ir-cr-book/ir-a1.html#wp7654966010
alarm-report	http://www.cisco.com/c/en/us/td/docs/ios-xml/ios/interface/command/ir-cr-book/ir-a1.html#wp2800999060
aps adm	http://www.cisco.com/c/en/us/td/docs/ios-xml/ios/interface/command/ir-cr-book/ir-a1.html#wp8015117230
aps group	http://www.cisco.com/c/en/us/td/docs/ios-xml/ios/interface/command/ir-cr-book/ir-a1.html#wp1674734739
aps protect	http://www.cisco.com/c/en/us/td/docs/ios-xml/ios/interface/command/ir-cr-book/ir-a1.html#wp2073867702
aps revert	http://www.cisco.com/c/en/us/td/docs/ios-xml/ios/interface/command/ir-cr-book/ir-a1.html#wp4063780600
aps unidirectional	http://www.cisco.com/c/en/us/td/docs/ios-xml/ios/interface/command/ir-cr-book/ir-a1.html#wp5340799170
aps working	http://www.cisco.com/c/en/us/td/docs/ios-xml/ios/interface/command/ir-cr-book/ir-a1.html#wp8949584630
cem-group <i>cem-group-number cep</i>	http://www.cisco.com/c/en/us/td/docs/ios-xml/ios/interface/command/ir-cr-book/ir-c1.html#wp2440628600
controller mediatype	http://www.cisco.com/c/en/us/td/docs/ios-xml/ios/interface/command/ir-cr-book/ir-c2.html#wp1201337639
controller protection-group	http://www.cisco.com/c/en/us/td/docs/ios-xml/ios/mcl/allreleasemcl/all-book/all-03.html
controller sonet	http://www.cisco.com/c/en/us/td/docs/ios-xml/ios/interface/command/ir-cr-book/ir-c2.html#wp2020468554

Commands	Links
clock source	http://www.cisco.com/c/en/us/td/docs/ios-xml/ios/interface/command/ir-cr-book/ir-c2.html#wp3604380959
loopback	http://www.cisco.com/c/en/us/td/docs/ios-xml/ios/interface/command/ir-cr-book/ir-l2.html#wp2735045490
mode sonet	http://www.cisco.com/c/en/us/td/docs/ios-xml/ios/interface/command/ir-cr-book/ir-l2.html#wp2327088950
mode sts-nc	http://www.cisco.com/c/en/us/td/docs/ios-xml/ios/interface/command/ir-cr-book/ir-l2.html#wp1791424945
mode vt-15	http://www.cisco.com/c/en/us/td/docs/ios-xml/ios/interface/command/ir-cr-book/ir-l2.html#wp1137973905
overhead c2	http://www.cisco.com/c/en/us/td/docs/ios-xml/ios/interface/command/ir-cr-book/ir-o1.html#wp1973678817
overhead j0	http://www.cisco.com/c/en/us/td/docs/ios-xml/ios/interface/command/ir-cr-book/ir-o1.html#wp4338698890
overhead j1	http://www.cisco.com/c/en/us/td/docs/ios-xml/ios/interface/command/ir-cr-book/ir-o1.html#wp1987243836
overhead s1s0	http://www.cisco.com/c/en/us/td/docs/ios-xml/ios/interface/command/ir-cr-book/ir-o1.html#wp2779929239
protection-group	http://www.cisco.com/c/en/us/td/docs/ios-xml/ios/mcl/allreleasemcl/all-book/all-10.html
protection-group [working protect]	http://www.cisco.com/c/en/us/td/docs/ios-xml/ios/mcl/allreleasemcl/all-book/all-10.html
rate [OC3 OC12 OC48 OC192]	http://www.cisco.com/c/en/us/td/docs/ios-xml/ios/interface/command/ir-cr-book/ir-o1.html#wp4442889730
shutdown	http://www.cisco.com/c/en/us/td/docs/ios-xml/ios/interface/command/ir-cr-book/ir-s6.html#wp3364503641
show controllers sonet	http://www.cisco.com/c/en/us/td/docs/ios-xml/ios/interface/command/ir-cr-book/ir-s3.html#wp1341372847

Commands	Links
show hw-module subslot transceiver	http://www.cisco.com/c/en/us/td/docs/ios-xml/ios/interface/command/ir-cr-book/ir-s4.html#wp6553420000
show protection-group	http://www.cisco.com/c/en/us/td/docs/ios-xml/ios/mcl/allreleasemcl/all-book/all-14.html
sts-1	http://www.cisco.com/c/en/us/td/docs/ios-xml/ios/interface/command/ir-cr-book/ir-s6.html#wp2423232697
t1 t1-line-number framing	http://www.cisco.com/c/en/us/td/docs/ios-xml/ios/interface/command/ir-cr-book/ir-t1.html#wp2623191253
t1 t1-line-number clock source	http://www.cisco.com/c/en/us/td/docs/ios-xml/ios/interface/command/ir-cr-book/ir-t1.html#wp3480850667
threshold	http://www.cisco.com/c/en/us/td/docs/ios-xml/ios/interface/command/ir-cr-book/ir-t1.html#wp2311589330
type sts48c	http://www.cisco.com/c/en/us/td/docs/ios-xml/ios/mcl/allreleasemcl/all-book/all-15.html
vtg vtg-line-number t1 t1-line-number loopback	http://www.cisco.com/c/en/us/td/docs/ios-xml/ios/interface/command/ir-cr-book/ir-t2.html#wp3494199143

Additional References for Configuring SONET on 1-Port OC192/STM-64 or 8-Port OC3/12/48/STM-1/-4/-16 Interface Module

Related Documents

Related Topic	Document Title
Cisco IOS commands	http://www.cisco.com/en/US/docs/ios/mcl/allreleasemcl/all_book.html

Standards

Standards	Title
—	There are no standards for this feature.

MIBs

MIB	MIBs Link
—	<p>To locate and download MIBs for selected platforms, Cisco IOS releases, and feature sets, use Cisco MIB Locator found at the following URL:</p> <p>http://www.cisco.com/go/mibs</p>

RFCs

RFCs	Title
—	There are no RFCs for this feature.

Technical Assistance

Description	Link
<p>The Cisco Support website provides extensive online resources, including documentation and tools for troubleshooting and resolving technical issues with Cisco products and technologies.</p> <p>To receive security and technical information about your products, you can subscribe to various services, such as the Product Alert Tool (accessed from Field Notices), the Cisco Technical Services Newsletter, and Really Simple Syndication (RSS) Feeds.</p> <p>Access to most tools on the Cisco Support website requires a Cisco.com user ID and password.</p>	<p>http://www.cisco.com/cisco/web/support/index.html</p>



CHAPTER 4

Alarm History

Alarm history or alarm persistence feature enables the maintenance of the history of the port and the path alarms of interface modules.

History of the port-level and path-level alarms are saved into a file and is retained for monitoring network events.

- [Alarm History Restrictions, on page 85](#)
- [Configuring Alarm History, on page 86](#)
- [Verifying Alarm History Configuration, on page 86](#)
- [Associated Commands, on page 87](#)
- [Additional References for Alarm History, on page 87](#)

Alarm History Restrictions

The following restrictions apply for the alarm history feature:

- Only port and path level alarm history or alarm persistency is supported.
- Persistence of T1 alarms on a Channelized T3/E3 port or 1-Port OC-192 or 8-Port Low Rate CEM Interface Module is not supported.
- Two new files are created after each reboot.
- The primary and secondary log files are created during feature initialization. The primary log file saves 10000 alarms. When the threshold of 10000 alarms in the primary log file is crossed, the subsequent 10000 alarms are saved in the secondary log file. After crossing the threshold of 10000 alarms in the secondary log file, the content of primary log file is cleared and is replaced with the subsequent alarms.
- When a primary file switches to a secondary file and vice versa, the following happens:
 - An information level syslog message is displayed.
 - An informatory message is written in the file where subsequent alarms are stored.
- When a standby RSP switches over, the alarm history files are not copied to the new active RSP. Two new files are created in the new active RSP.

Configuring Alarm History

The configuration of alarm history helps in defining the periodicity or the interval at which the alarm entries are saved in the designated file. To configure alarm history:

```
enable
configure terminal
service alarm persistency interval <20-600>
end
```

When alarm history is configured, two log files are created in bootflash:tracelogs in the following format:

```
<persistent_alarm[1/2][TIME_STAMP(DD_MMMM_YYYY_HH_MM_SSS)].log>
```

The syslog message is displayed as the following after configuration:

```
*Jun 15 10:16:51.270: %ALARM_PERSISTENCY-6-ALARM_INFO_PROCESS_CREATE: created
mcprp_spa_persistence_logger process:292
*Jun 15 10:16:51.270: %ALARM_PERSISTENCY-6-ALARM_CHUNK_INFO_CREATED: chunk pool creation
for alarm_info is successful
*Jun 15 10:16:51.270: %ALARM_PERSISTENCY-6-ALARM_CHUNK_QUEUE_CREATED: chunk pool for
alarm_queue is successful
*Jun 15 10:16:51.283: %ALARM_PERSISTENCY-6-ALARM_INFO_FILE_CREATED: Successfully created
/bootflash/tracelogs/persistent_alarm_1.15_June_2016_10_16__270.log file
Router#
*Jun 15 10:16:51.295: %ALARM_PERSISTENCY-6-ALARM_INFO_FILE_CREATED: Successfully created
/bootflash/tracelogs/persistent_alarm_2.15_June_2016_10_16__270.log file
*Jun 15 10:16:52.541: %SYS-5-CONFIG_I: Configured from console by console
Router#
```

Verifying Alarm History Configuration

Use the **show process | include persistent** command to verify the validity of the process.

```
Router#show process | include persistent
 292 Msi 13F0D4AC          0          49          010328/12000  0 mcprp_spa_persistent
Router#
```

Verify the contents of the persistent alarm log files using the following commands:

```
Router#dir bootflash:tracelogs/*persistent*
Directory of bootflash:tracelogs/*persistent*
394172 -rw-          1606 Jun 15 2016 07:50:39 +00:00
persistent_alarm_1.15_June_2016_07_46__158.log
394173 -rw-          6299 Jun 15 2016 07:50:38 +00:00
persistent_alarm_2.15_June_2016_07_46__158.log
6185086976 bytes total (4867022848 bytes free)
Router#

Router#more bootflash:tracelogs/persistent_alarm_1.15_June_2016_07_46__158.log
At:15_June_2016_07_50__916 contents of persistent_alarm_2.15_June_2016_07_46__158.log are
full, so switched to this file
*07:50:19.360 UTC Wed Jun 15 2016|SLOT_0 |BAY_3 |PORT_0 |2 |1 |6 |4
|SONET_SDH_PATH_VT/TU_ALARM|MAJOR|VT_UNEQUIPPED|CLEARED
*07:50:19.360 UTC Wed Jun 15 2016|SLOT_0 |BAY_3 |PORT_0 |2 |1 |6 |4
|SONET_SDH_PATH_VT/TU_ALARM|MAJOR|VT_PATH_LOP|RAISED
*07:50:19.360 UTC Wed Jun 15 2016|SLOT_0 |BAY_3 |PORT_0 |2 |1 |7 |1
|SONET_SDH_PATH_VT/TU_ALARM|MAJOR|VT_UNEQUIPPED|CLEARED
*07:50:19.360 UTC Wed Jun 15 2016|SLOT_0 |BAY_3 |PORT_0 |2 |1 |7 |1
|SONET_SDH_PATH_VT/TU_ALARM|MAJOR|VT_PATH_LOP|RAISED
*07:50:19.360 UTC Wed Jun 15 2016|SLOT_0 |BAY_3 |PORT_0 |2 |1 |7 |2
```

```

|SONET_SDH_PATH_VT/TU_ALARM|MAJOR|VT_UNEQUIPPED|CLEARED
*07:50:19.360 UTC Wed Jun 15 2016|SLOT_0 |BAY_3 |PORT_0 |2 |1 |7 |2
|SONET_SDH_PATH_VT/TU_ALARM|MAJOR|VT_PATH_LOP|RAISED
*07:50:19.360 UTC Wed Jun 15 2016|SLOT_0 |BAY_3 |PORT_0 |2 |1 |7 |3
|SONET_SDH_PATH_VT/TU_ALARM|MAJOR|VT_UNEQUIPPED|CLEARED
*07:50:19.361 UTC Wed Jun 15 2016|SLOT_0 |BAY_3 |PORT_0 |2 |1 |7 |3
|SONET_SDH_PATH_VT/TU_ALARM|MAJOR|VT_PATH_LOP|RAISED
*07:50:19.361 UTC Wed Jun 15 2016|SLOT_0 |BAY_3 |PORT_0 |2 |1 |7 |4
|SONET_SDH_PATH_VT/TU_ALARM|MAJOR|VT_UNEQUIPPED|CLEARED
*07:50:19.361 UTC Wed Jun 15 2016|SLOT_0 |BAY_3 |PORT_0 |2 |1 |7 |4
|SONET_SDH_PATH_VT/TU_ALARM|MAJOR|VT_PATH_LOP|RAISED
*07:50:23.333 UTC Wed Jun 15 2016|SLOT_0 |BAY_3 |PORT_0 |1 |1 |1 |1
|SONET_SDH_PATH_VT/TU_ALARM|MAJOR|VT_UNEQUIPPED|CLEARED
*07:50:27.335 UTC Wed Jun 15 2016|SLOT_0 |BAY_3 |PORT_0 |1 |1 |1 |1
|SONET_SDH_PATH_VT/TU_PDH_DS1_ALARM|NA|DS1_AIS|CLEARED

```

Router#

Associated Commands

The following commands are used to configure alarm history:

Commands	Links
service alarm persistency interval	http://www.cisco.com/c/en/us/td/docs/ios-xml/ios/interface/command/ir-cr-book/ir-s1.html#wp3501057143
show process include persis	http://www.cisco.com/c/en/us/td/docs/ios-xml/ios/interface/command/ir-cr-book/ir-s5.html#wp9298909580

Additional References for Alarm History

Related Documents

Related Topic	Document Title
Cisco IOS commands	Cisco IOS Master Commands List, All Releases

Standards

Standards	Title
—	There are no standards for this feature.

MIBs

MIB	MIBs Link
—	To locate and download MIBs for selected platforms, Cisco IOS releases, and feature sets, use Cisco MIB Locator found at the following URL: http://www.cisco.com/go/mibs

RFCs

RFCs	Title
—	There are no RFCs for this feature.

Technical Assistance

Description	Link
<p>The Cisco Support website provides extensive online resources, including documentation and tools for troubleshooting and resolving technical issues with Cisco products and technologies.</p> <p>To receive security and technical information about your products, you can subscribe to various services, such as the Product Alert Tool (accessed from Field Notices), the Cisco Technical Services Newsletter, and Really Simple Syndication (RSS) Feeds.</p> <p>Access to most tools on the Cisco Support website requires a Cisco.com user ID and password.</p>	http://www.cisco.com/cisco/web/support/index.html



CHAPTER 5

Clock Recovery System for SAToP

The Clock Recovery System recovers the service clock using Adaptive Clock Recovery (ACR) and Differential Clock Recovery (DCR).

- [Finding Feature Information](#), on page 89
- [Information About Clock Recovery](#), on page 89
- [Prerequisites for Clock Recovery](#), on page 91
- [Restrictions for Clock Recovery](#), on page 92
- [How to Configure Adaptive Clock Recovery \(ACR\)](#), on page 92
- [Example: Adaptive Clock Recovery \(ACR\) for SAToP](#), on page 99
- [Example: Differential Clock Recovery \(DCR\) for SAToP](#), on page 100
- [Additional References for Clock Recovery](#), on page 101

Finding Feature Information

Your software release may not support all the features documented in this module. For the latest caveats and feature information, see [Bug Search Tool](#) and the release notes for your platform and software release. To find information about the features documented in this module, and to see a list of the releases in which each feature is supported, see the feature information table.

Use Cisco Feature Navigator to find information about platform support and Cisco software image support. To access Cisco Feature Navigator, go to <https://cfng.cisco.com/>. An account on Cisco.com is not required.

Information About Clock Recovery

Adaptive Clock Recovery (ACR)

Adaptive Clock Recovery (ACR) is an averaging process that negates the effect of random packet delay variation and captures the average rate of transmission of the original bit stream. ACR recovers the original clock for a synchronous data stream from the actual payload of the data stream. In other words, a synchronous clock is derived from an asynchronous packet stream. ACR is a technique where the clock from the TDM domain is mapped through the packet domain, but is most commonly used for Circuit Emulation (CEM). ACR is supported on unframed and framed modes of SAToP.



Note Framing type should be maintained same in all routers end to end.

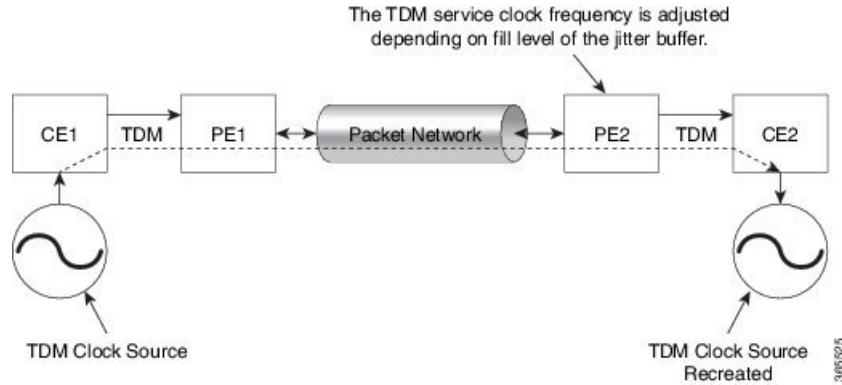

Differential Clock Recovery (DCR)

Differential Clock Recovery (DCR) is another technique used for Circuit Emulation (CEM) to recover clocks based on the difference between PE clocks. TDM clock frequency are tuned to receive differential timing messages from the sending end to the receiving end. A traceable clock is used at each end, which ensures the recovered clock is not affected by packet transfer. DCR is supported on unframed and framed modes of SAToP.



Note Framing type should be maintained same in all routers end to end.

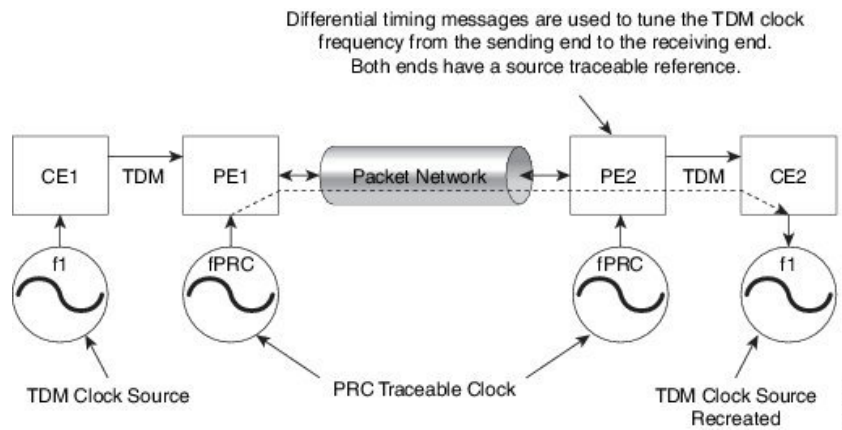

Explicit Pointer Adjustment Relay (EPAR)

A pointer management system is defined as part of the definition of SONET. If there is a frequency offset between the frame rate of the transport overhead and that of the SONET Synchronous Payload Envelope (SPE), the alignment of the SPE slips back periodically or advances in time through positive or negative stuffing. Similarly, if there is a frequency offset between the SPE rate and the VT rate it carries, the alignment

of the VT slips back periodically or advances in time through positive or negative stuffing within the SPE. The emulation of this aspect of SONET network in pseudowire emulation network may be accomplished using EPAR feature.

EPAR uses N and P bits in CEP header to signal negative or positive pointer justification event. EPAR is supported on STS-1, STS-3C, STS-12C, STS-48C and VT-1.5 levels. N and P counters are added to communicate the signaling of the pointer events over CEP pseudowire.

Figure 4: EPAR

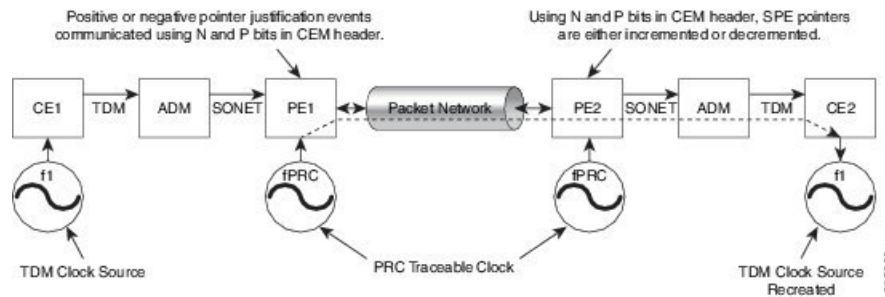

Effective Cisco IOS-XE Release 3.18 SP, EPAR is enabled by default.

Restrictions for EPAR

- EPAR is applicable only for circuit emulation for SONET LO & HO paths and is not applicable for PDH.
- EPAR is effective only when both ends of the pseudowire have access to a common timing reference.

Benefits of Clock Recovery

- Customer-edge devices (CEs) can have different clock from that of the Provide-edge devices (PEs).

Scaling Information

IM Card	Pseudowires Supported (Number of Clocks Derived)
DS1	48
DS3	1344
1-Port OC192/STM-64 or 8-Port OC3/12/48/STM-1/-4/-16 Interface Module	2000

Prerequisites for Clock Recovery

- The clock of interface modules must be used as service clock.
- CEM must be configured before configuring the global clock recovery.
- RTP must be enabled for DCR in CEM, as the differential clock information is transferred in the RTP header.

Restrictions for Clock Recovery

- The reference clock source is used and locked to a single clock.
- The clock ID should be unique for a particular interface module for ACR or DCR configuration.
- When CEM group is configured, dynamic change in clock source is not allowed.
- ACR clock configuration under each controller should be performed before configuring CEM group.
- When ACR or DCR is configured and loopback network is applied on the same PDH (T1/E1), then the ACR or DCR mode configuration is removed to enable the loopback. The ACR or DCR should be configured again after the loopback maintenance activity.

Scale Restrictions

- For the Cisco IOS XE Amsterdam 17.3.x release, a maximum of **5376** ACR and DCR session scale is supported on the Cisco 1-port OC-192 Interface module or 8-port Low Rate Interface Module (8-port SFP GE and 1-port 10GE IM with CEM, 10G). For releases before the Cisco IOS XE Amsterdam 17.3.1 release, only 2000 session are supported.

How to Configure Adaptive Clock Recovery (ACR)

Configuring ACR for OCn

Configuring ACR in Mode VT15 for SAToP

You must configure ACR for virtual tributary groups (VTG) mode. In this mode, a single STS-1 is divided into seven VTGs. Each VTG is then divided into four VT1.5, each carrying a T1.

To configure ACR in mode VT15 for Structure-Agnostic TDM over Packet (SAToP):

```
enable
configure terminal
controller sonet <bay>/<slot>/<port>
rate OC3
sts-1 <number>
mode vt-15
vtg 1 t1 cem 0 unframed
vtg 1 t1 1 clock source recovered 1
vtg <vtg_number> t1 <t1_number> cem-group <cem-group-no> unframed
vtg <vtg_number> t1 <t1_number> clock source recovered <clock-id>
exit
recovered-clock 0 <0-15> Subslot number
end
```

Verifying ACR in Mode VT15 for SAToP

Verifying ACR Configuration

```
Router# show running-config | section 0/4/0

controller MediaType 0/4/0
```

```

mode sonet
controller SONET 0/4/0
rate OC48
no ais-shut
framing sonet
clock source internal
!
sts-1 1
clock source internal
mode vt-15
vtg 1 t1 1 clock source Recovered 0
vtg 1 t1 1 framing unframed
vtg 1 t1 1 cem-group 0 unframed

interface CEM0/4/0
no ip address
cem 0
!
```

Verifying Recovered Clock

```
Router# show recovered-clock
```

```
Recovered clock status for subslot 0/3
```

```
-----
Clock      Type      Mode      CEM      Status      Frequency Offset(ppb)  Circuit-No
0          OCx-ds1  ADAPTIVE   0        ACQUIRED   n/a                    0/1/1/1
(Port/path/vtg/t1)
```

```
Router# show running-config | section recovered-clock 0 4
```

```
recovered-clock 0 4
clock recovered 0 adaptive cem 0 0
```

Configuring ACR in mode T3 for SAToP

You must configure ACR in mode T3. Mode T3 is STS-1 or AU-4/TUG3 carrying an unchannelized (clear channel) T3.

```

enable
configure terminal
recovered-clock <bay> <slot>
clock recovered <clock-id> adaptive cem <port-no> <cem-group-no>
controller sonet <bay>/<slot>/<port>
rate OC3
sts-1 <number>
mode t3
cem-group < cem-group-no> unframed
t3 clock source recovered <clock-id>

end
```

Verifying ACR in Mode T3 for SAToP

Verifying ACR Configuration

```

Router# show run | sec recovered
recovered-clock bay/slot
clock recovered clock_id adaptive cem cem-group-no port-no
!

Router# show running-config | section 0/4/6
```

```

controller SONET 0/4/6
  rate OC3
  no ais-shut
  framing sonet
  clock source internal
  !
sts-1 1
  clock source internal
  mode t3
  t3 clock source line
  cem-group 0 unframed
  clock source recovered 20

interface CEM0/4/6
  no ip address
  cem 0
  !

```

Verifying Recovered Clock

```
Router# show recovered-clock
```

```
Recovered clock status for subslot 0/3
```

```
-----
```

Clock	Type	Mode	CEM	Status	Frequency	Offset (ppb)	Circuit-No
0	OCx-ds3	ADAPTIVE	0	ACQUIRED	n/a		0/1

```

(Port/t3)

```

```
Router# show run | sec recovered
```

```

recovered-clock 0 4
clock recovered 20 adaptive cem 6 0
!

```

Configuring ACR in Mode CT3 for SAToP

You must configure ACR in mode CT3. Mode CT3 is an STS-1 carrying a DS3 signal that is divided into 28 T1s (PDH).

```

enable
configure terminal
recovered-clock <bay> <slot>
clock recovered <clock-id> adaptive cem <port-no> <cem-group-no>
controller sonet <bay>/<slot>/<port>
rate OC3
sts-1 <number>
mode ct3
t1 <t1_number> cem-group <cem-group-no> unframed
t1 <t1_number> clock source recovered <clock-id>
enable

```

Verifying ACR in Mode CT3 for SAToP

Verifying ACR Configuration

```
Router# show running-config | section 0/4/0
```

```

controller MediaType 0/4/0
  mode sonet
controller SONET 0/4/0
  rate OC48
  no ais-shut

```

```

framing sonet
clock source internal
!
sts-1 1
  clock source internal
  mode ct3
  t3 framing c-bit
  t1 1 clock source Recovered 10
  t1 1 framing unframed
  t1 1 cem-group 1 unframed

interface CEM0/4/0
  no ip address
  cem 1
!
```

Verifying Recovered Clock

```
show recovered-clock
```

```
Recovered clock status for subslot 0/3
```

```
-----
Clock   Type      Mode      CEM   Status      Frequency Offset(ppb)  Circuit-No
0       OCx-ds1  ADAPTIVE   0     ACQUIRED   n/a                    0/1/1
(Port/t3/t1)
```

```
show running-config | section recovered-clock 0 4
recovered-clock 0 4
  clock recovered 10 adaptive cem 1 0
```

Configuring DCR for OCn

Configuring DCR in Mode VT15 for SAToP

```

enable
configure terminal
recovered-clock <bay> <slot>
clock recovered <clock-id> differential cem <port-no> <cem-group-no>
controller sonet <bay>/<slot>/<port>
rate OC3
sts-1 <number>
mode vt-15
vtg <vtg_no> t1 <t1_number> cem-group <cem-group-no> unframed
vtg <vtg_no> t1 <t1_number> clock source recovered <clock-id>
interface cem <bay>/<slot>/<port>
cem <cem-group-number>
rtp-present
end
```

Verifying DCR in Mode VT15 for SAToP

Verifying DCR Configuration

```
Router# show running-config | section 0/4/0
```

```

controller MediaType 0/4/0
  mode sonet
controller SONET 0/4/0
  rate OC48
  no ais-shut
  framing sonet
```

```

clock source internal
!
sts-1 1
  clock source internal
  mode vt-15
  vtg 1 t1 1 clock source Recovered 0
  vtg 1 t1 1 framing unframed
  vtg 1 t1 1 cem-group 0 unframed

interface CEM0/4/0
  no ip address
  cem 0
  rtp-present
!
```

Verifying Recovered Clock

```
Router# show recovered-clock
```

```
Recovered clock status for subslot 0/4
```

```
-----
```

Clock	Type	Mode	CEM	Status	Frequency Offset(ppb)	Circuit-No
0	OCx-dsl	Differential	0	ACQUIRED	n/a	0/1/1/1
(Port/path/vtg/t1)						

```
Router# show running-config | section recovered-clock 0 4
```

```
recovered-clock 0 4
  clock recovered 0 differential cem 0 0
```

Configuring DCR in Mode CT3 for SAToP

```

enable
configure terminal
recovered-clock <bay> <slot>
clock recovered <clock-id> differential cem <port-no> <cem-group-no>
controller sonet <bay>/<slot>/<port>
rate OC3
sts-1 <number>
mode ct3
t1 <t1_number> cem-group <cem-group-no> unframed
t1 <t1_number> clock source recovered <clock-id>
interface cem <bay>/<slot>/<port>
  cem <cem-group-number>
  rtp-present
end
```

Verifying DCR in Mode CT3 for SAToP

Verifying DCR Configuration

```
Router# show running-config | section 0/4/0
```

```

controller MediaType 0/4/0
  mode sonet
controller SONET 0/4/0
  rate OC48
  no ais-shut
  framing sonet
  clock source internal
!
sts-1 1
```



```

clock source internal
mode ct3
t3 framing c-bit
t1 1 clock source Recovered 10
t1 1 framing unframed
t1 1 cem-group 1 unframed

interface CEM0/4/0
no ip address
cem 1
  rtp-present
!
```

Verifying Recovered Clock

```
Router# show recovered-clock
```

```
Recovered clock status for subslot 0/4
```

```
-----
Clock   Type      Mode      CEM   Status      Frequency Offset(ppb)  Circuit-No
0       OCx-ds1   Differential  0     ACQUIRED    n/a                    0/1/1
(Port/t3/t1)
```

```
Router# show running-config | section recovered-clock 0 4
recovered-clock 0 4
  clock recovered 10 differential cem 1 0
```

Configuring DCR in Mode T3 for SAToP

```

enable
configure terminal
recovered-clock <bay> <slot>
clock recovered <clock-id> differential cem <port-no> <cem-group-no>
controller sonet <bay>/<slot>/<port>
rate OC3
sts-1 <number>
mode t3
cem-group <cem-group-number> unframed
t3 clock source recovered <clock-id>
interface cem <bay>/<slot>/<port>
cem <cem-group-nber>
rtp-present
end
```

Verifying DCR in Mode T3 for SAToP

Verifying DCR Configuration

```
Router# show running-config | section 0/4/6
```

```

controller SONET 0/4/6
  rate OC3
  no ais-shut
  framing sonet
  clock source internal
  !
  sts-1 1
  clock source internal
  mode t3
  cem-group 0 unframed
  clock source recovered 20
```

```
interface CEM0/4/6
no ip address
cem 0
 rtp-present
!
```

Verifying Recovered Clock

```
Router# show recovered-clock
```

```
Recovered clock status for subslot 0/4
```

```
-----
Clock   Type      Mode      CEM   Status      Frequency Offset(ppb)  Circuit-No
0       OCx-ds3   Differential  0     ACQUIRED    n/a                    0/1
(Port/t3)
```

```
Router# show running-config | section recovered-clock 0 4
```

```
recovered-clock 0 4
clock recovered 20 differential cem 6 0
```

Verification of EPAR Configuration

The following example shows the configuration of EPAR for STS-3c with negative pointer adjustment events signaled using N-bits.

```
Router#show cem circuit interface cem 0/4/4 104
```

```
CEM0/4/4, ID: 104, Line: UP, Admin: UP, Ckt: ACTIVE
Controller state: up, CEP state: up
Idle Pattern: 0xFF, Idle CAS: 0x8
Dejitter: 6 (In use: 0)
Payload Size: 783
Framing: Not-Applicable
CEM Defects Set
None
```

```
Signalling: No CAS
RTP: No RTP
```

```
Ingress Pkts:      8507028158          Dropped:          0
Egress Pkts:       8507028151          Dropped:          0
```

```
CEM Counter Details
```

```
Input Errors:      0                Output Errors:    0
Pkts Missing:     0                Pkts Reordered:  0
Misorder Drops:   0                JitterBuf Underrun: 0
Error Sec:        0                Severly Errored Sec: 0
Unavailable Sec:  0                Failure Counts:   0
Pkts Malformed:  0                JitterBuf Overrun: 0
Generated Lbits:  0                Received Lbits:   0
Generated Rbits:  0                Received Rbits:   0
Generated Nbits:  81794328         Received Nbits:   81794328
Generated Pbits:  0                Received Pbits:   0
```

Recovering a Clock

Recovering an ACR Clock

```
enable
configure terminal
recovered-clock <bay> <slot>
```

```
clock recovered <clock-id> adaptive cem <port-no> <cem-group-no>
end
```

Recovering a DCR Clock

```
enable
configure terminal
recovered-clock <bay> <slot>
clock recovered <clock-id> differential cem <port-no> <cem-group-no>
end
```

Example: Adaptive Clock Recovery (ACR) for SAToP

Example: Adaptive Clock Recovery (ACR) Mode VT15 for SAToP

```
enable
configure terminal
recovered-clock 0 4
clock recovered 0 adaptive cem 0 0
controller SONET 0/4/0
rate OC48
sts-1 1
mode vt-15
vtg 1 t1 1 cem-group 0 unframed
vtg 1 t1 1 clock source Recovered 0
end
```

Example: Adaptive Clock Recovery (ACR) Mode CT3 for SAToP

```
enable
configure terminal
recovered-clock 0 4
clock recovered 10 adaptive cem 1 0
controller SONET 0/4/0
rate OC48
sts-1 1
mode ct-3
t1 1 cem-group 1 unframed
t1 1 clock source Recovered 10
end
```

Example: Adaptive Clock Recovery (ACR) Mode T3 for SAToP

```
enable
configure terminal
recovered-clock 0 4
clock recovered 20 adaptive cem 6 0
controller SONET 0/4/6
rate OC48
sts-1 1
mode t3
cem-group 0 unframed
t3 clock source recovered 20
end
```

Example: Differential Clock Recovery (DCR) for SAToP

Example: Differential Clock Recovery (DCR) Mode VT15 for SAToP

```
enable
configure terminal
recovered-clock 0 4
clock recovered 0 differential cem 0 0
controller SONET 0/4/0
rate OC48
sts-1 1
mode vt-15
vtg 1 t1 1 cem-group 0 unframed
vtg 1 t1 1 clock source Recovered 0
interface CEM 0/4/0
cem 1
rtp-present
end
```

Example: Differential Clock Recovery (DCR) Mode CT3 for SAToP

```
enable
configure terminal
recovered-clock 0 4
clock recovered 10 differential cem 1 0
controller SONET 0/4/0
rate OC48
sts-1 1
mode ct3
t1 1 cem-group 1 unframed
t1 1 clock source Recovered 10
interface CEM 0/4/0
cem 1
rtp-present
end
```

Example: Differential Clock Recovery (DCR) Mode T3 for SAToP

```
enable
configure terminal
controller SONET 0/4/0
rate OC48
sts-1 1
mode ct3
t1 1 cem-group 1 unframed
t1 1 clock source Recovered 10
recovered-clock 0 4
clock recovered 10 differential cem 0 1
interface CEM 0/4/0
cem 1
rtp-present
end
```

Additional References for Clock Recovery

Related Documents

Related Topic	Document Title
Cisco IOS commands	Cisco IOS Master Commands List, All Releases

Standards and RFCs

Standard/RFC	Title
ITU -T G.8261	<i>Timing and synchronization aspects in packet networks</i>

MIBs

MIB	MIBs Link
—	To locate and download MIBs for selected platforms, Cisco IOS releases, and feature sets, use Cisco MIB Locator found at the following URL: http://www.cisco.com/go/mibs

Technical Assistance

Description	Link
<p>The Cisco Support website provides extensive online resources, including documentation and tools for troubleshooting and resolving technical issues with Cisco products and technologies.</p> <p>To receive security and technical information about your products, you can subscribe to various services, such as the Product Alert Tool (accessed from Field Notices), the Cisco Technical Services Newsletter, and Really Simple Syndication (RSS) Feeds.</p> <p>Access to most tools on the Cisco Support website requires a Cisco.com user ID and password.</p>	http://www.cisco.com/cisco/web/support/index.html

