



Cisco Firepower 2100 Series Hardware Installation Guide

First Published: 2017-05-25

Last Modified: 2019-11-14

Americas Headquarters

Cisco Systems, Inc.
170 West Tasman Drive
San Jose, CA 95134-1706
USA
<http://www.cisco.com>
Tel: 408 526-4000
800 553-NETS (6387)
Fax: 408 527-0883

THE SPECIFICATIONS AND INFORMATION REGARDING THE PRODUCTS IN THIS MANUAL ARE SUBJECT TO CHANGE WITHOUT NOTICE. ALL STATEMENTS, INFORMATION, AND RECOMMENDATIONS IN THIS MANUAL ARE BELIEVED TO BE ACCURATE BUT ARE PRESENTED WITHOUT WARRANTY OF ANY KIND, EXPRESS OR IMPLIED. USERS MUST TAKE FULL RESPONSIBILITY FOR THEIR APPLICATION OF ANY PRODUCTS.

THE SOFTWARE LICENSE AND LIMITED WARRANTY FOR THE ACCOMPANYING PRODUCT ARE SET FORTH IN THE INFORMATION PACKET THAT SHIPPED WITH THE PRODUCT AND ARE INCORPORATED HEREIN BY THIS REFERENCE. IF YOU ARE UNABLE TO LOCATE THE SOFTWARE LICENSE OR LIMITED WARRANTY, CONTACT YOUR CISCO REPRESENTATIVE FOR A COPY.

The following information is for FCC compliance of Class A devices: This equipment has been tested and found to comply with the limits for a Class A digital device, pursuant to part 15 of the FCC rules. These limits are designed to provide reasonable protection against harmful interference when the equipment is operated in a commercial environment. This equipment generates, uses, and can radiate radio-frequency energy and, if not installed and used in accordance with the instruction manual, may cause harmful interference to radio communications. Operation of this equipment in a residential area is likely to cause harmful interference, in which case users will be required to correct the interference at their own expense.

The following information is for FCC compliance of Class B devices: This equipment has been tested and found to comply with the limits for a Class B digital device, pursuant to part 15 of the FCC rules. These limits are designed to provide reasonable protection against harmful interference in a residential installation. This equipment generates, uses and can radiate radio frequency energy and, if not installed and used in accordance with the instructions, may cause harmful interference to radio communications. However, there is no guarantee that interference will not occur in a particular installation. If the equipment causes interference to radio or television reception, which can be determined by turning the equipment off and on, users are encouraged to try to correct the interference by using one or more of the following measures:

- Reorient or relocate the receiving antenna.
- Increase the separation between the equipment and receiver.
- Connect the equipment into an outlet on a circuit different from that to which the receiver is connected.
- Consult the dealer or an experienced radio/TV technician for help.

Modifications to this product not authorized by Cisco could void the FCC approval and negate your authority to operate the product.

The Cisco implementation of TCP header compression is an adaptation of a program developed by the University of California, Berkeley (UCB) as part of UCB's public domain version of the UNIX operating system. All rights reserved. Copyright © 1981, Regents of the University of California.

NOTWITHSTANDING ANY OTHER WARRANTY HEREIN, ALL DOCUMENT FILES AND SOFTWARE OF THESE SUPPLIERS ARE PROVIDED "AS IS" WITH ALL FAULTS. CISCO AND THE ABOVE-NAMED SUPPLIERS DISCLAIM ALL WARRANTIES, EXPRESSED OR IMPLIED, INCLUDING, WITHOUT LIMITATION, THOSE OF MERCHANTABILITY, FITNESS FOR A PARTICULAR PURPOSE AND NONINFRINGEMENT OR ARISING FROM A COURSE OF DEALING, USAGE, OR TRADE PRACTICE.

IN NO EVENT SHALL CISCO OR ITS SUPPLIERS BE LIABLE FOR ANY INDIRECT, SPECIAL, CONSEQUENTIAL, OR INCIDENTAL DAMAGES, INCLUDING, WITHOUT LIMITATION, LOST PROFITS OR LOSS OR DAMAGE TO DATA ARISING OUT OF THE USE OR INABILITY TO USE THIS MANUAL, EVEN IF CISCO OR ITS SUPPLIERS HAVE BEEN ADVISED OF THE POSSIBILITY OF SUCH DAMAGES.

Any Internet Protocol (IP) addresses and phone numbers used in this document are not intended to be actual addresses and phone numbers. Any examples, command display output, network topology diagrams, and other figures included in the document are shown for illustrative purposes only. Any use of actual IP addresses or phone numbers in illustrative content is unintentional and coincidental.

All printed copies and duplicate soft copies of this document are considered uncontrolled. See the current online version for the latest version.

Cisco has more than 200 offices worldwide. Addresses and phone numbers are listed on the Cisco website at www.cisco.com/go/offices.

Cisco and the Cisco logo are trademarks or registered trademarks of Cisco and/or its affiliates in the U.S. and other countries. To view a list of Cisco trademarks, go to this URL: <https://www.cisco.com/c/en/us/about/legal/trademarks.html>. Third-party trademarks mentioned are the property of their respective owners. The use of the word partner does not imply a partnership relationship between Cisco and any other company. (1721R)

© 2017-2024 Cisco Systems, Inc. All rights reserved.



CONTENTS

CHAPTER 1

Overview 1

Features	1
Deployment Options	5
Package Contents	5
QR Code Sticker	8
Serial Number Location	9
Front Panel	10
Front Panel LEDs	12
Rear Panel	17
Network Modules	19
10-Gb Network Module	19
1-Gb Network Module	21
Hardware Bypass Network Modules	22
1-Gb SX/10-Gb SR/10-Gb LR Network Module with Hardware Bypass	23
1-Gb Network Module with Hardware Bypass	26
Power Supply Modules	27
Fan Modules	30
SSDs	30
Supported SFP/SFP+ Transceivers	31
Hardware Specifications	33
Product ID Numbers	34
Power Cord Specifications	37

CHAPTER 2

Installation Preparation 43

General Safety Warnings	43
Network Equipment-Building System (NEBS) Statements	45

Safety Recommendations	47
Maintain Safety with Electricity	47
Prevent ESD Damage	48
Site Environment	48
Site Considerations	48
Power Supply Considerations	49
Rack Configuration Considerations	49

CHAPTER 3 **Rack-Mount and Ground the Chassis** 51

Unpack and Inspect the Chassis	51
Rack-Mount the Chassis Using Brackets	52
Rack-Mount the Chassis Using Slide Rails	55
Ground the Chassis	60

CHAPTER 4 **Installation, Maintenance, and Upgrade** 63

Install, Remove, and Replace the Network Module	63
Remove and Replace the SSD	65
Remove and Replace the Power Supply Module	68
Connect the DC Power Supply Module	71
Secure the Power Cord on the Power Supply Module	75
Remove and Replace the Fan Tray	78
Install the FIPS Opacity Shield in a Two-Post Rack	80
Install the FIPS Opacity Shield in a Four-Post Rack	83



CHAPTER 1

Overview

- [Features, on page 1](#)
- [Deployment Options, on page 5](#)
- [Package Contents, on page 5](#)
- [QR Code Sticker, on page 8](#)
- [Serial Number Location, on page 9](#)
- [Front Panel, on page 10](#)
- [Front Panel LEDs, on page 12](#)
- [Rear Panel, on page 17](#)
- [Network Modules, on page 19](#)
- [Hardware Bypass Network Modules, on page 22](#)
- [Power Supply Modules, on page 27](#)
- [Fan Modules, on page 30](#)
- [SSDs, on page 30](#)
- [Supported SFP/SFP+ Transceivers, on page 31](#)
- [Hardware Specifications, on page 33](#)
- [Product ID Numbers, on page 34](#)
- [Power Cord Specifications, on page 37](#)

Features

The Cisco Firepower 2100 series security appliance is a standalone modular security services platform. The series includes the Firepower 2110, 2120, 2130, and 2140. See [Product ID Numbers, on page 34](#) for a list of the product IDs (PIDs) associated with the 2100 series.

The Firepower 2100 series supports Cisco Firepower Threat Defense and Cisco ASA software. See the [Cisco Firepower Compatibility Guide](#) and the [Cisco ASA Compatibility](#) guide, which provide Cisco software and hardware compatibility, including operating system and hosting environment requirements, for each supported version.

The following figures show the Firepower 2100 series.

Figure 1: Firepower 2110 and 2120



Figure 2: Firepower 2130 and 2140



The following table lists the features for the Firepower 2100 series.

Table 1: Firepower 2100 Series Features

Feature	2110	2120	2130	2140
Form factor	1 RU Fits a standard 19-inch (48.3-cm) square-hole rack			
Rack mount	Two 2-post mount brackets (Optional) 4-post Electronic Industries Association (EIA)-310-D rack		4-post EIA-310-D rack (Optional) Two 2-post mount brackets	
Airflow	Front to rear Cold aisle to hot aisle			
Intel x86 processor	Single 4-core at 1.8 G	Single 6-core at 1.9 G	Single 8-core at 2.0 G	Single 16-core at 1.3 G
Intel x86 memory	16 GB DDR4 DRAM		32 GB DDR4 DRAM	64 GB DDR4 DRAM
Cavium Network Processor Unit (NPU)	Single 6-core at 1.2 G	Single 8-core at 1.2 G	Single 12-core at 1.2 G	Single 16-core at 1.8 G
Cavium NPU RAM	8 G		16G	
Flash	8 G (nominal)			

Feature	2110	2120	2130	2140
Maximum number of interfaces	16		24	
Management port	1 Gigabit Ethernet (10 M/100 M/1 G Base-T)			
Console port	RJ-45 serial port			
USB port	USB 2.0 Type A (500 mA)			
Network ports	12 fixed RJ-45 1 G/100 M/10 M ports (named Ethernet 1/1 through 1/12)			
Small form-factor pluggable (SFP) ports	Four fixed 1-G SFP ports		Four fixed 1-G/10-G SFP+ ports	
Pullout asset card	Displays serial number			
Grounding lug	On rear panel			
Locator beacon	On front panel			
Power switch	On rear panel			
Network module slots	No		One <i>Not</i> hot-swappable	
Network modules	—		<ul style="list-style-type: none"> • 8-port 1-Gigabit Ethernet SFP • 8-port 10-Gigabit Ethernet SFP+ • 8-port 1-Gigabit Ethernet copper with hardware bypass • 6-port 1-Gigabit Ethernet SX fiber SFP (built-in) with hardware bypass • 6-port 10-Gigabit Ethernet SR fiber SFP+ (built-in) with hardware bypass • 6-port 10-Gigabit Ethernet LR fiber SFP+ (built-in) with hardware bypass 	
AC power supply	One fixed AC power supply module		Two power supply slots Ships with one 400-W AC power supply module Hot-swappable	Two power supply slots Ships with two 400-W AC power supply modules Hot-swappable
DC power supply	No		Yes (optional)	
Redundant power	No		Yes	

Feature	2110	2120	2130	2140
Fan	Two fixed fans Internal component only; not field-replaceable		One hot-swappable fan tray with four fans	
Storage	Two SSD slots (100 GB) Ships with one 100-GB SSD installed in slot 1 Note We may ship larger capacity SSDs depending on component supply availability. The larger capacity SSDs are formatted to 100-GB for the Firepower 2110 and 2120. Slot 2 is reserved for the Malware Storage Pack (MSP).		Two SSD slots (200 GB) Ships with one 200-GB SSD installed in slot 1 Note We may ship larger capacity SSDs depending on component supply availability. The larger capacity SSDs are formatted to 200-GB for the Firepower 2130 and 2140. Slot 2 is reserved for the MSP.	
MSP	Installed in SSD slot 2			
Security standards certifications	<ul style="list-style-type: none"> • Common Criteria Certification for the Network Device Collaborative Protection Profile (NDcPPv2.2E), VPN Gateway Module (VPNGW_MOD_v1.1), and Firewall Module (FW_MOD_v1.4e) for ASA 9.16.x. • Common Criteria Certification for the Network Device Collaborative Protection Profile (NDcPPv2.2E), IPS Extended Package (IPSEP v2.11), Firewall Collaborative Protection Profile Module (MOD_FW_v1.4e), and Virtual Private Network Gateway Protection Profile Module (MOD_VPNGW_v1.1) on ASA 9.12.x, FTD 6.4.x and FX-OS 2.6.x • Federal Information Processing Standards (FIPS) 410-2 (FTD 6.4.x, FX-OS 2.6.x, and ASA 9.12.x) • Department of Defense Information Network Approved Product List (DoDIN APL) • US Government Compliance for IPv6 (USGv6) (FTD 6.4.x and ASA 9.12.x) • USGv6 Certification Approval under the R1 Profile for the Product Classification NPP (FTD 7.0.x) <p>Note See Install the FIPS Opacity Shield in a Two-Post Rack, on page 80 and Install the FIPS Opacity Shield in a Four-Post Rack, on page 83 for the procedures for installing the FIPS shield and for configuring the 2100 for FIPS mode.</p>			
Network Equipment Building Systems (NEBS) certification	—	—	Certified	—

Deployment Options

Here are some examples of how you can deploy the Firepower 2100:

- As a firewall:
 - At the enterprise Internet edge deployed in a high availability configuration
 - At branch offices in either a high availability pair or standalone
- As a device that provides additional application control, URL filtering, or IPS/threat-centric capabilities:
 - Behind an enterprise internet edge firewall in an inline in a transparent bump-in-the-wire configuration or as a standalone (requires hardware fail open network module support)
 - Deployed passively off a SPAN port on a switch or a tap on a network, or standalone
- As a VPN device:
 - For remote access VPN
 - For site-to-site VPN

Package Contents

The following figure shows the package contents for the Firepower 2110 and 2120. The contents are subject to change and your exact contents will contain additional or fewer items depending on whether you order the optional parts. See [Product ID Numbers, on page 34](#) for a list of the PIDs associated with the Firepower 2110 and 2120 package contents.



Note There are three sets of four screws that you can use to secure the chassis to your rack. Chose the screws that fit your rack.

Figure 3: Firepower 2110 and 2120 Package Contents

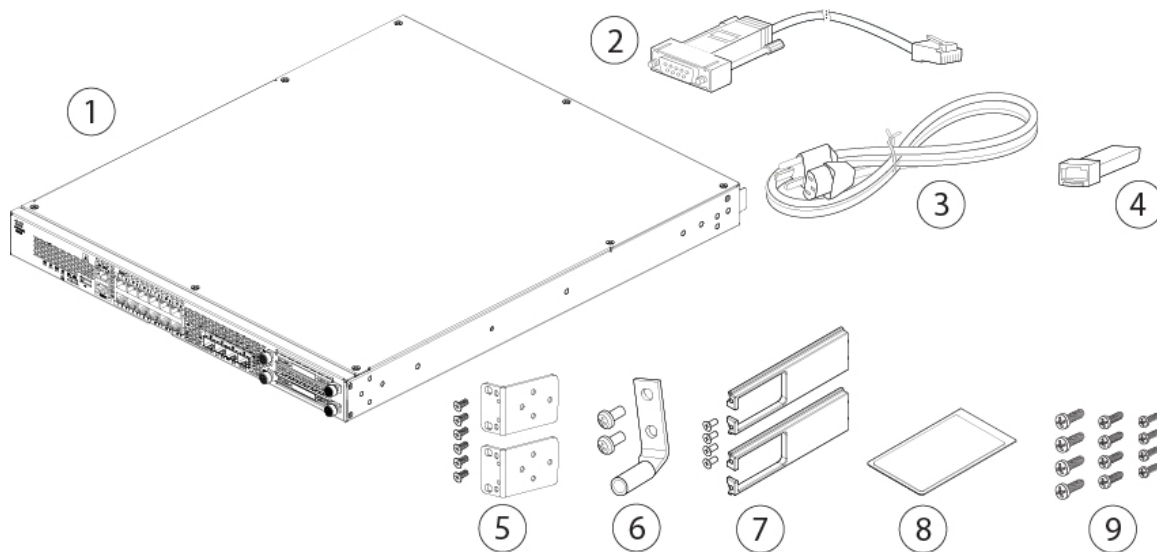

<p>1 Firepower 2110 or 2120 chassis</p>	<p>2 Console cable RJ-45 to DB-9 (part number 72-3383-01)</p>
<p>3 One power cord (country-specific) See Power Cord Specifications, on page 37 for the list of supported power cords.</p>	<p>4 SFP transceiver (Optional; in package if ordered)</p>
<p>5 Two rack-mount brackets (part number 700-106374-01) and six Phillips 8-32 x 0.281-inch screws (part number 48-101518-01)</p>	<p>6 One ground lug kit (part number 69-100359-01)</p> <ul style="list-style-type: none"> • One #6 AWG, 90 degree, #10 post ground lug (part number 32-0608-01) • Two 10-32 x 0.38-inch Phillips screws
<p>7 Cable management bracket kit (part number 69-100376-01)</p> <ul style="list-style-type: none"> • Two cable management brackets (part number 700-106377-01) • Four 8-32 x 0.375-inch Phillips screws (part number 48-2696-01) <p>(Optional; in package if ordered)</p>	<p>8 <i>Cisco Secure Firepower 2100</i></p> <p>This document has a URL and QR code that point to the Digital Documentation Portal. The portal contains links to the Product Information page, the Hardware Installation Guide, the Regulatory and Safety Information Guide, the Getting Started Guide, and the Easy Deployment Guide.</p>

9	<p>Rack-mount screws:</p> <ul style="list-style-type: none"> • Four 12-24 x 0.75-inch Phillips screws (part number 648-0440-01) for securing the chassis to your rack • Four 10-32 x 0.75-inch Phillips screws (part number 48-0441-01) for securing the chassis to your rack • Four M6 x 1 x 19-mm Phillips screws (part number 48-101022-01) for securing the chassis to your rack 	
----------	---	--

The following figure shows the package contents for the Firepower 2130 and 2140. The contents are subject to change and your exact contents will contain additional or fewer items depending on whether you order the optional parts. See [Product ID Numbers, on page 34](#) for a list of the product IDs (PIDs) associated with the Firepower 2130 and 2140 package contents.

Figure 4: Firepower 2130 and 2140 Package Contents

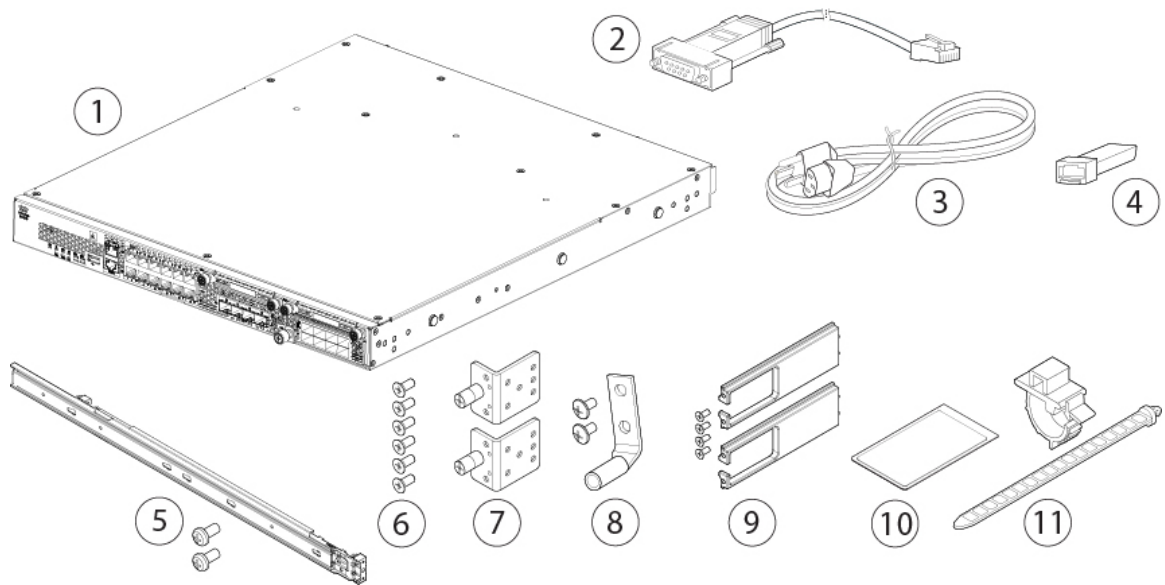

1	<p>Firepower 2130 or 2140 chassis</p>	2	<p>Console cable RJ-45 to DB-9 (part number 72-3383-01)</p>
3	<p>One or two power cords (country-specific) See Power Cord Specifications, on page 37 for a list of supported power cords.</p>	4	<p>SFP transceiver (Optional; in package if ordered)</p>
5	<p>Slide rail kit (part number 800-103711-01)</p> <ul style="list-style-type: none"> • Left and right slide rails • Two M3 x 0.5 x 6-mm Phillips screws (part number 48-101144-01) 	6	<p>Six 8-32 x 0.25-inch slide rail locking bracket Phillips screws (part number 48-101429-01)</p>

7	Two slide rail locking brackets (part number 700-105350-01)	8	One ground lug kit (part number 69-100359-01) <ul style="list-style-type: none"> • One #6 AWG, 90 degree, #10 post ground lug (part number 32-0608-01) • Two 10-32 x 0.38-inch Phillips screws
9	Cable management bracket kit (part number 69-100376-01) <ul style="list-style-type: none"> • Two cable management brackets (part number 700-106377-01) • Four 8-32 x 0.375-inch Phillips screws (part number 48-2696-01) (Optional; in package if ordered)	10	<i>Cisco Secure Firepower 2100</i> This document has a URL and QR code that point to the Digital Documentation Portal. The portal contains links to the Product Information page, the Hardware Installation Guide, the Regulatory and Safety Information Guide, the Getting Started Guide, and the Easy Deployment Guide.
11	Two power supply module tie wraps and clamps (part number 52-100162-01)	—	—

QR Code Sticker

The QR code sticker on the front panel of the chassis points to the [Easy Deployment Guide for Cisco Secure Firewall 1000, 2100, and 3100 Series](#) that explains low touch provisioning (LTP). LTP allows anyone to connect a new Firepower 2100 to a network so that the IT department can onboard the device to CDO and configure it remotely. CDO supports Firepower Threat Defense (FTD) version 6.7 and later.

The following figure shows the QR code sticker.

Figure 5: QR Code Sticker



The following figure shows the placement of the QR code sticker on the front panel of the Firepower 2100 chassis.

Figure 6: QR Code Sticker on the Firepower 2100 Front Panel

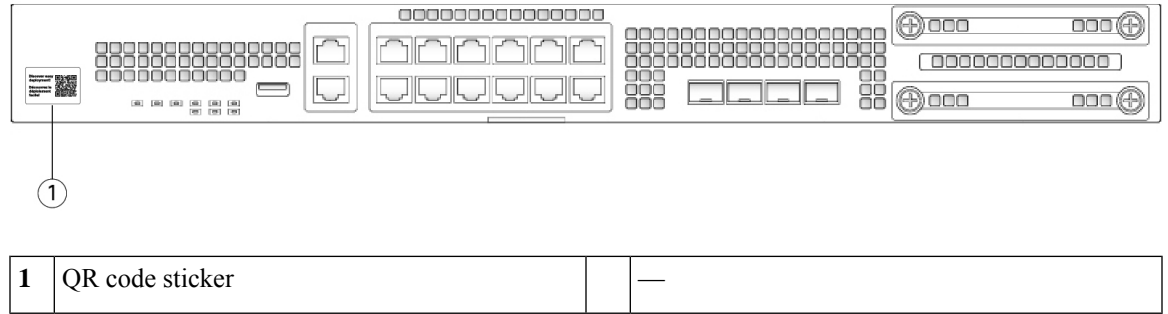

Serial Number Location

The serial number for the Firepower 2100 series chassis is located on the pullout asset card on the front panel.

Figure 7: Serial Number on the Chassis

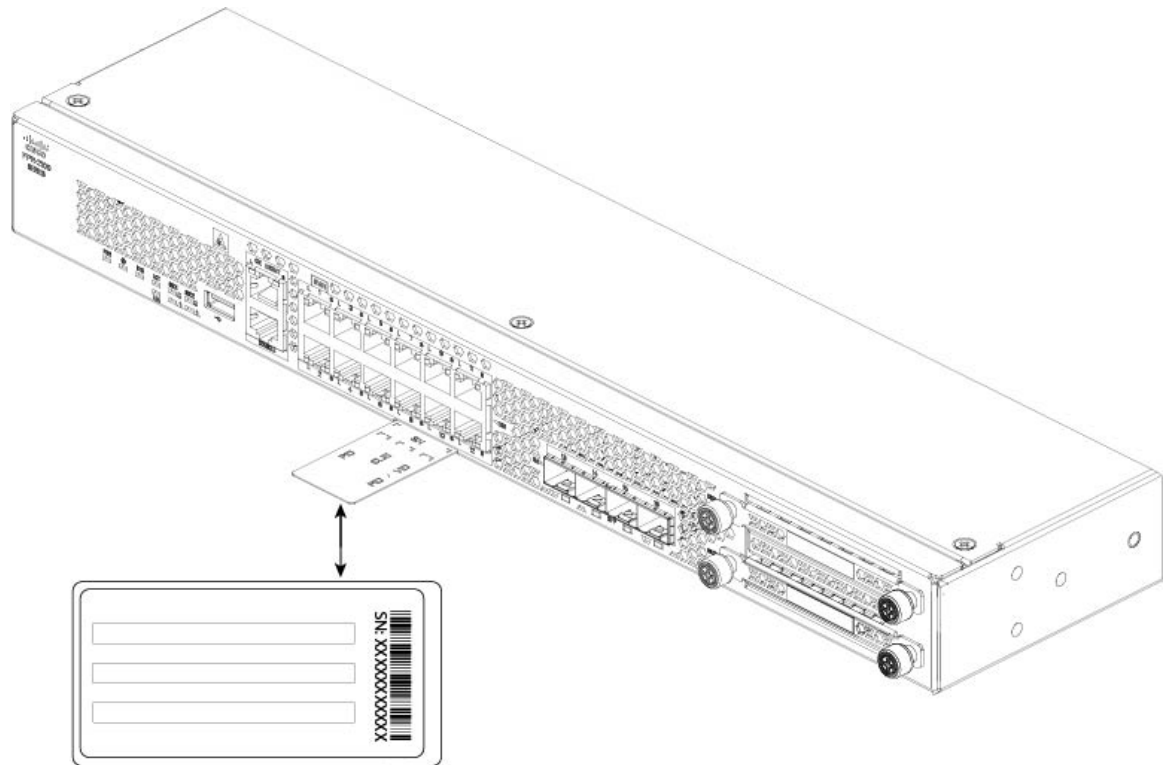

You can also view additional model information on the compliance label located on the bottom of the chassis.

Figure 8: Compliance Label on the Chassis

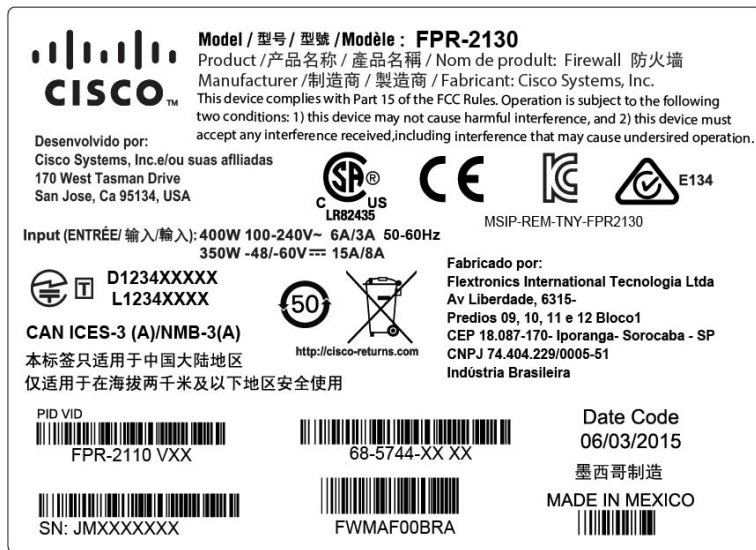

Front Panel

The following figure shows the front panel of the Firepower 2110 and 2120. See [Front Panel LEDs, on page 12](#) for a description of the LEDs.

Figure 9: Firepower 2110 and 2120 Front Panel

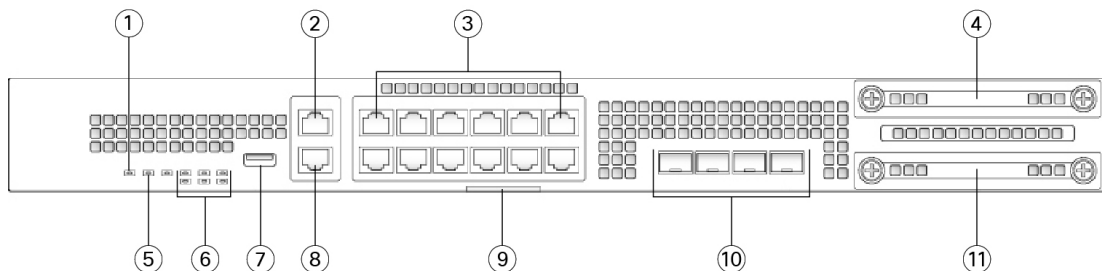

<p>1 Power LED</p>	<p>2 Gigabit Ethernet management port:</p> <ul style="list-style-type: none"> • Firepower Threat Defense—Management 0 (also referred to as Management 1/1 and Diagnostic 1/1) • ASA—Management 1/1
<p>3 12 RJ-45 1 G/10 M/10 M auto duplex/auto MDI-X Base-T ports</p> <p>Ethernet 1/1 through 1/12 labeled top to bottom, left to right</p>	<p>4 SSD 1 (slot 1)</p>

5	Locator LED	6	System LEDs
7	Type A USB 2.0 port	8	RJ-45 console port
9	Pullout asset card with chassis serial number	10	Four fixed SFP (1 Gb) ports Fiber ports 1/13 through 1/16 labeled left to right
11	SSD (slot 2)		—

The following figure shows the front panel of the Firepower 2130 and 2140. See [Front Panel LEDs](#), on page 12 for a description of the LEDs.

Figure 10: Firepower 2130 and 2140 Front Panel

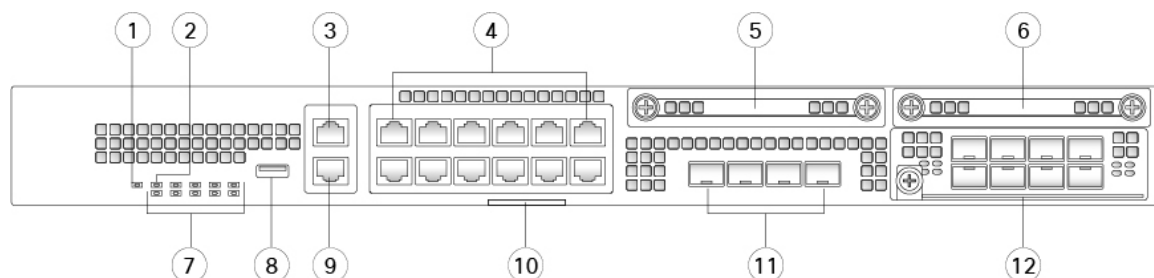

1	Power LED	2	Locator LED
3	Gigabit Ethernet management port: <ul style="list-style-type: none"> • Firepower Threat Defense—Management 0 (also referred to as Management 1/1 and Diagnostic 1/1) • ASA—Management 1/1 	4	12 RJ-45 1 G/100 M/10 M auto duplex/auto MDI-X Base-T ports Ethernet 1/1 through 1/12 labeled top to bottom, left to right
5	SSD 1	6	SSD 2
7	System LEDs	8	Type A USB 2.0 port
9	RJ-45 console port	10	Pullout asset card with chassis serial number
11	Four fixed SFP+ (1 Gb/10 Gb) ports Fiber ports 1/13 through 1/16 labeled left to right	12	Network module (network module slot 1)

Management Port

The Firepower 2100 chassis has an RJ-45 copper management port.

RJ-45 Console Port

The Firepower 2100 chassis has a standard RJ-45 console port. You can use the CLI to configure your 2100 through the RJ-45 serial console port by using a terminal server or a terminal emulation program on a computer.

The RJ-45 (8P8C) port supports RS-232 signaling to an internal UART controller. The console port does not have any hardware flow control, and does not support a remote dial-in modem. The baud rate is 9600. You can use the standard cable found in your accessory kit to convert the RJ-45 to DB-9 if necessary.

Type A USB Port

You can use the external Type A USB port to attach a data-storage device. The external USB drive identifier is `usbA:`. The Type A USB port supports the following:

- Hot swapping
- USB drive formatted with FAT32
- Boot kickstart image from ROMMON for discovery recovery purposes
- Copy files to and from `workspace:/` and `volatile:/` within local-mgmt. The most relevant files are:
 - Core files
 - Ethalyzer packet captures
 - Tech-support files
 - Security module log files
- Platform bundle image upload using **download image usbA:**

The Type A USB port does *not* support Cisco Secure Package (CSP) image upload support.

Network Ports

The Firepower 2100 chassis has 12 fixed RJ-45 1 G/100 M/10 M) ports. They are numbered from top to bottom, left to right starting with 1 and are named Ethernet 1/1 through Ethernet 1/12.

The Firepower 2110 and 2120 also have four fixed SFP (1 Gb) ports, and the Firepower 2130 and 2140 have four fixed SFP+ (1 Gb/10 Gb) ports. They are fiber ports numbered left to right (1/13 through 1/16).

Each port has LEDs that represent Link/Activity status.

Front Panel LEDs

The following figure shows the Firepower 2110 and 2120 front panel LEDs.

Figure 11: Firepower 2110 and 2120 Front Panel LEDs

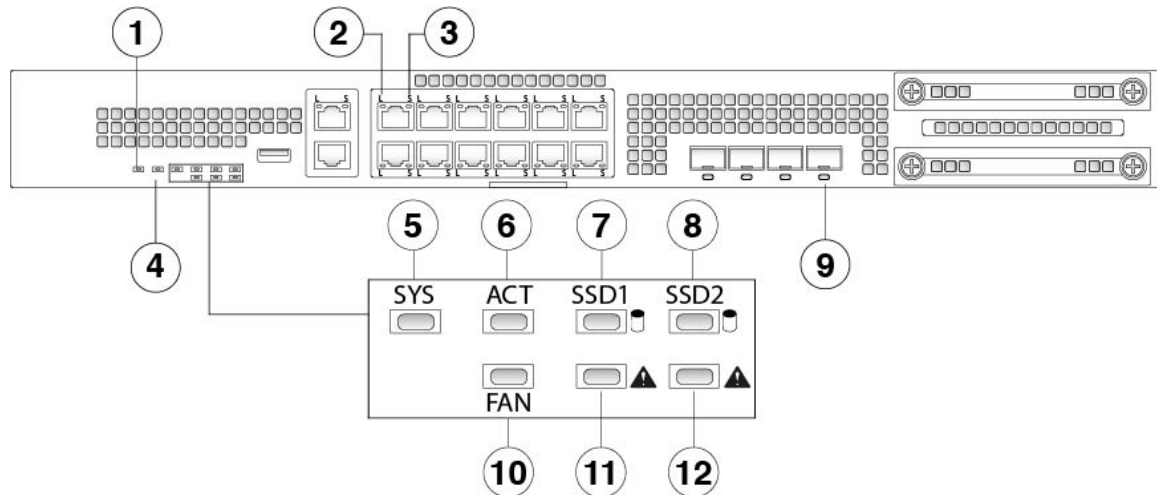

<p>1 PWR</p> <ul style="list-style-type: none"> • Off—Input power is not detected. Standby power is off. • Green, flashing—System has detected a power switch toggle event, and initiated the shutdown sequence. <p>Note If the power switch is in the OFF position, the system powers off after shutdown is completed. Do not remove the AC or DC power source while this LED is blinking so that the system has time to perform a graceful shutdown.</p> <ul style="list-style-type: none"> • Amber—System is powering up (before the BIOS boots). This takes one to five seconds at most. • Green—System is fully powered up. 	<p>2 Ethernet Link</p> <ul style="list-style-type: none"> • Green—The link partner is detected; no activity. • Green, flashing—Network activity is detected.
<p>3 Ethernet Speed</p> <ul style="list-style-type: none"> • Green, flashing—The number of flashes determines link speed; 1 flash=10 Mbit, 2=100 Mbit, 3=1 Gbit. 	<p>4 Locator</p> <ul style="list-style-type: none"> • Off—Locate is off. • Blue—Locate is on. <p>Note The Locator LED helps you locate a unit that needs physical service attention. This feature is activated in the software.</p>

<p>5 SYS (Health)</p> <ul style="list-style-type: none"> • Off—System has not booted up yet. • Green, flashing quickly—System is booting up. • Green—Normal system function. • Amber—System boot up has failed. • Amber, flashing—Alarm condition, system needs service or attention and may not boot properly. • Green, flashing slowly (twice in 5 seconds)—Cloud connected. <p>Note Cisco Defense Orchestrator (CDO) is valid for FTD 6.7 and later.</p> <ul style="list-style-type: none"> • Green and amber, flashing—Cloud connection failure. • Green—Cloud disconnected. <p>Note The CDO LED pattern applies to low touch provisioning (LTP). See the Firepower Easy Deployment Guide for Cisco Firepower 1000 or 2100 Firewalls for more information.</p>	<p>6 ACT (Role of a high-availability pair)</p> <ul style="list-style-type: none"> • Off—Unit is not configured or enabled in a high-availability pair. • Green—Unit is in active mode. • Amber—Unit is in standby mode.
<p>7 SSD1</p> <ul style="list-style-type: none"> • Off—SSD is not present. • Green—SSD is present; no activity. • Green, flashing—SSD is active. 	<p>8 SSD2</p> <ul style="list-style-type: none"> • Off—SSD is not present. • Green—SSD is present; no activity. • Green, flashing—SSD is active.
<p>9 Fiber Port</p> <ul style="list-style-type: none"> • Green—Port is enabled, the link partner is detected. • Amber—Port is enabled, but the link partner is not detected. • Green, flashing—Port is enabled; network activity is detected. 	<p>10 FAN</p> <ul style="list-style-type: none"> • Off—Environmental subsystem is not active yet. • Green—Fans are running normally. It may take up to one minute for the LED status to turn green after power is on. • Amber—One fan has failed. The system can continue to operate normally, but fan service is required. • Amber, flashing—Two or more fans have failed, or the fan tray has been removed from the system. Immediate attention is required.

<p>11 SSD1 Alert Status</p> <ul style="list-style-type: none"> • Off—SSD has normal activity. • Amber—SSD failure. 	<p>12 SSD2 Alert Status</p> <ul style="list-style-type: none"> • Off—SSD has normal activity. • Amber—SSD failure.
---	---

The following figure shows the Firepower 2130 and 2140 front panel LEDs.

Figure 12: Firepower 2130 and 2140 Front Panel LEDs

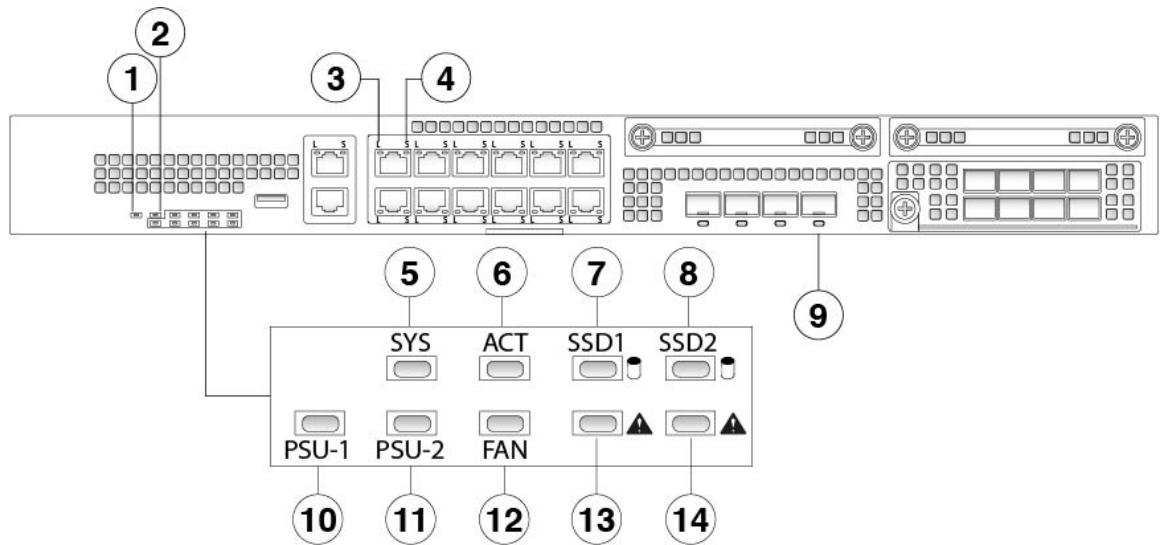

<p>1 Power</p> <ul style="list-style-type: none"> • Off—Input power is not detected. Standby power is off. • Green, flashing—The system has detected a power switch toggle event, and initiated the shutdown sequence. If the power switch is in the OFF position, the system powers off after shutdown is completed. Do not remove the AC or DC power source while this LED is blinking so that the system has time to perform a graceful shutdown. • Amber—The system is powering up (before the BIOS boots). This takes one to five seconds at most. • Green—The system is fully powered up. 	<p>2 Locator</p> <ul style="list-style-type: none"> • Off—Locate is off. • Blue—Locate is on. <p>Note The Locator LED helps you locate a unit that needs physical service attention. This feature is activated in the software.</p>
--	---

<p>3 Ethernet Link</p> <ul style="list-style-type: none"> • Green—The link partner is detected; no activity. • Green, flashing—Network activity is detected. 	<p>4 Ethernet Speed</p> <ul style="list-style-type: none"> • Green, flashing—The number of flashes determines link speed; 1 flash=10 Mbit, 2=100 Mbit, 3=1 Gbit.
<p>5 SYS (Health)</p> <ul style="list-style-type: none"> • Off—System has not booted up yet. • Green, flashing quickly—System is booting up. • Green—Normal system function. • Amber—System boot up has failed. • Amber, flashing—Alarm condition, system needs service or attention and may not boot properly. • Green, flashing slowly (twice in 5 seconds)—Cloud connected. <p>Note Cisco Defense Orchestrator (CDO) is valid for FTD 6.7 and later.</p> <ul style="list-style-type: none"> • Green and amber, flashing—Cloud connection failure. • Green—Cloud disconnected. <p>Note The CDO LED pattern applies to low touch provisioning (LTP). See the Firepower Easy Deployment Guide for Cisco Firepower 1000 or 2100 Firewalls for more information.</p>	<p>6 ACT (Role of a high-availability pair)</p> <ul style="list-style-type: none"> • Off—The unit is not configured or enabled in a high-availability pair. • Green—The unit is in active mode. • Amber—The unit is in standby mode.
<p>7 SSD1</p> <ul style="list-style-type: none"> • Off—The SSD is not present. • Green—The SSD is present; no activity. • Green, flashing—The SSD is active. 	<p>8 SSD2</p> <ul style="list-style-type: none"> • Off—The SSD is not present. • Green—The SSD is present; no activity. • Green, flashing—The SSD is active.

<p>9 Fiber Port</p> <ul style="list-style-type: none"> • Green—Port is enabled, the link partner is detected. • Amber—Port is enabled, but the link partner is not detected. • Green, flashing—Port is enabled; network activity is detected. 	<p>10 PSU-1</p> <ul style="list-style-type: none"> • Off—The power supply module is not present or not detected. • Green—The power supply module is present and working properly. • Amber—The power supply module is present but a fault or problem has been detected.
<p>11 PSU-2</p> <ul style="list-style-type: none"> • Off—The power supply module is not present or not detected. • Green—The power supply module is present and working properly. • Amber—The power supply module is present but a fault or problem has been detected. 	<p>12 FAN</p> <ul style="list-style-type: none"> • Off—The environmental subsystem is not active yet. • Green—The fans are running normally. It may take up to one minute for the LED status to turn green after power is on. • Amber—One fan has failed. The system can continue to operate normally, but fan service is required. • Amber, flashing—Two or more fans have failed, or the fan tray has been removed from the system. Immediate attention is required.
<p>13 SSD1 Alert Status</p> <ul style="list-style-type: none"> • Off—SSD has normal activity. • Amber—SSD failure. 	<p>14 SSD2 Alert Status</p> <ul style="list-style-type: none"> • Off—SSD has normal activity. • Amber—SSD failure.

Rear Panel

The following figure shows the rear panel of the Firepower 2110 and 2120.

Figure 13: Firepower 2110 and 2120 Rear Panel

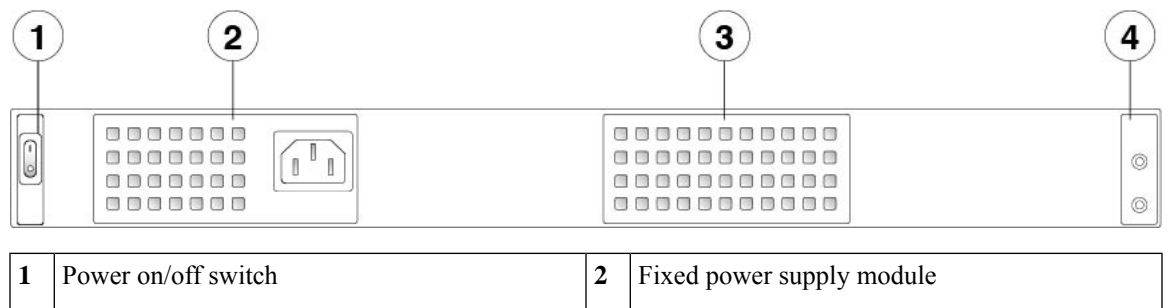

3 Fixed fans	4 Two-post grounding pad Note The two-post grounding lug is included in the accessory kit.
---------------------	---

The following figure shows the rear panel of the Firepower 2130 and 2140.

Figure 14: Firepower 2130 and 2140 Rear Panel

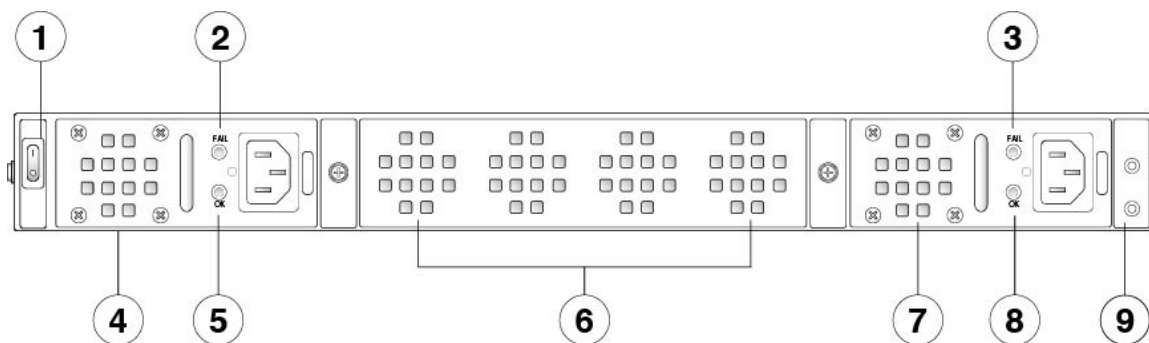

1 Power on/off switch	2 Power supply module 1 FAIL LED
3 Power supply module 2 FAIL LED	4 Power supply module 1
5 Power supply module 1 OK LED	6 Fan tray
7 Power supply module 2	8 Power supply module 2 OK LED
9 Two-post grounding pad Note The two-post grounding lug is included in the accessory kit.	

Power Switch

The power switch is located to the left of power supply module 1 on the rear of the chassis. It is a toggle switch that controls power to the system. If the power switch is in standby position, only the 3.3-V standby power is enabled from the power supply module and the 12-V main power is OFF. When the switch is in the ON position, the 12-V main power is turned on and the system boots.

Before you move the power switch to the OFF position, use the **shutdown** commands so that the system can perform a graceful shutdown. This may take several minutes to complete. After the graceful shutdown is complete, the console displays *It is safe to power off now*. The front panel blue locator beacon LED lights up indicating the system is ready to be powered off. You can now move the switch to the OFF position. The front panel PWR LED flashes momentarily and turns off.

See [Front Panel LEDs, on page 12](#) for the PWR LED description. See the [FXOS Configuration Guide](#) for more information on using the **shutdown** commands.



Note On the Firepower 2130 and 2140, the OK LEDs on the rear power supplies flash after the switch is turned off; this is expected behavior.

**Caution**

If you move the power switch to the OFF position before the **shutdown** command sequence is complete or if you remove the system power cords before the graceful shutdown is complete, disk corruption can occur.

**Note**

After removing power from the chassis by unplugging the power cord, wait at least 10 seconds before turning power back ON.

For More Information

- See [Remove and Replace the Power Supply Module, on page 68](#) for the procedure for removing and replacing the power supply module in the Firepower 2130 and 2140.
- See [Remove and Replace the Fan Tray, on page 78](#) for the procedure for removing and replacing the fan tray in the Firepower 2130 and 2140.
- See [Ground the Chassis, on page 60](#) for the procedure for using the grounding lug to ground the chassis.
- See [Power Supply Modules, on page 27](#) for a description of the power supply module LEDs.
- See [Front Panel LEDs, on page 12](#) for a description of the fan LEDs.

Network Modules

The Firepower 2130 and 2140 contain one network module slot that provides optical or electrical network interfaces. Network modules are optional, removable I/O modules that provide either additional ports or different interface types. The Firepower network module plugs into the chassis on the front panel.

For More Information

- See [10-Gb Network Module, on page 19](#) for a description of the 10-Gb network module.
- See [1-Gb Network Module, on page 21](#) for a description of the 1-Gb network module.
- See [Supported SFP/SFP+ Transceivers, on page 31](#) for a list of supported SFPs.
- See [Install, Remove, and Replace the Network Module, on page 63](#) for the procedure for removing and replacing network modules.

10-Gb Network Module

The following figure shows the front panel of the 10-Gb single-wide network module (FPR2K-NM-8X10G). The eight ports are numbered from top to bottom, left to right.



Note Make sure you have the correct firmware package and software version installed to support this network module. See [Cisco FXOS Troubleshooting Guide for the Firepower 1000/2100 with Firepower Threat Defense](#) for the procedure to verify your firmware package and software version. See [Cisco Firepower 2100 ASA Platform Mode FXOS Configuration Guide](#) for the procedure to upgrade the firmware package for the Firepower 2100 running ASA with FXOS. See the [Cisco Firepower Compatibility Guide](#) and the [Cisco ASA Compatibility guide](#), which provide Cisco software and hardware compatibility, including operating system and hosting environment requirements, for each supported version



Note The FPR2K-NM-8X10G is NEBS-compliant.



Note You can fit four copper SFPs in either the top row of ports or the bottom row of ports. Both rows cannot be populated at the same time, because of the port row spacing.

Figure 15: FPR2K-NM-8X10G

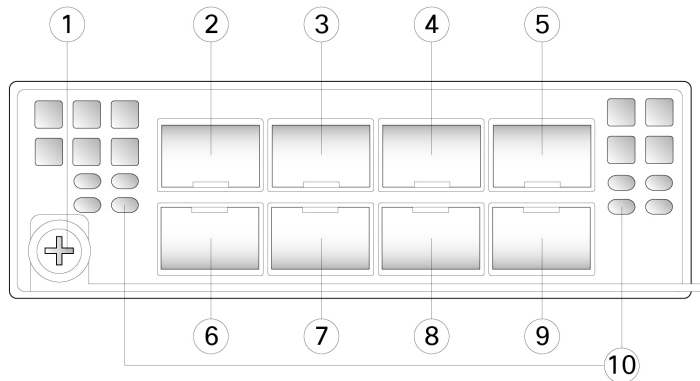

1	Captive screw/handle	2	Ethernet X/1
3	Ethernet X/3	4	Ethernet X/5
5	Ethernet X/7	6	Ethernet X/2
7	Ethernet X/4	8	Ethernet X/6
9	Ethernet X/8	10	Network activity LEDs <ul style="list-style-type: none"> • Off—No connection or port is not in use. • Amber—No link or network failure. • Green—Link up. • Green, flashing—Network activity.

For More Information

- For a list of copper SFPs, see [Supported SFP/SFP+ Transceivers, on page 31](#).

1-Gb Network Module

The following figure shows the front panel of the 1-Gb network module (FPR2K-NM-8X1G). The eight ports are numbered from top to bottom, left to right.



Note Make sure you have the correct firmware package and software version installed to support this network module. See [Cisco FXOS Troubleshooting Guide for the Firepower 1000/2100 with Firepower Threat Defense](#) for the procedure to verify your firmware package and software version. See [Cisco Firepower 2100 ASA Platform Mode FXOS Configuration Guide](#) for the procedure to upgrade the firmware package for the Firepower 2100 running ASA with FXOS. See the [Cisco Firepower Compatibility Guide](#) and the [Cisco ASA Compatibility guide](#), which provide Cisco software and hardware compatibility, including operating system and hosting environment requirements, for each supported version



Note The FPR2K-NM-8X1G is NEBS-compliant.



Note You can fit four copper SFPs in either the top row of ports or the bottom row of ports. Both rows cannot be populated at the same time, because of the port row spacing.

Figure 16: FPR2K-NM-8X1G

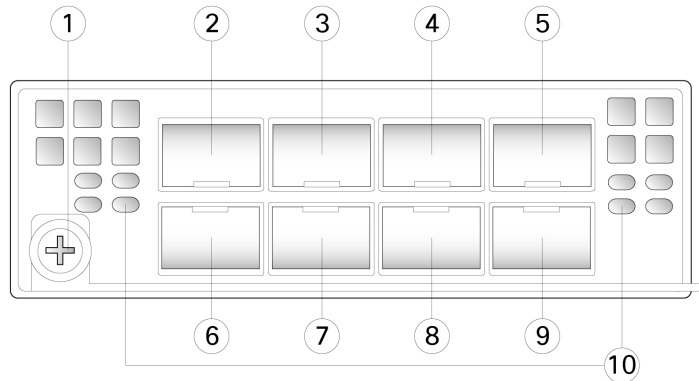

1	Captive screw/handle	2	Ethernet X/1
3	Ethernet X/3	4	Ethernet X/5
5	Ethernet X/7	6	Ethernet X/2

7	Ethernet X/4	8	Ethernet X/6
9	Ethernet X/8	10	Network activity LEDs <ul style="list-style-type: none"> • Off—No connection or port is not in use. • Amber—No link or network failure. • Green—Link up. • Green, flashing—Network activity.

For More Information

- For a list of copper SFPs, see [Supported SFP/SFP+ Transceivers, on page 31](#).

Hardware Bypass Network Modules

Hardware bypass (also known as fail-to-wire) is a physical layer (Layer 1) bypass that allows paired interfaces to go into bypass mode so that the hardware forwards packets between these port pairs without software intervention. Hardware bypass provides network connectivity when there are software or hardware failures. Hardware bypass is useful on ports where the Firepower security appliance is only monitoring or logging traffic. The hardware bypass network modules have an optical switch that is capable of connecting the two ports when needed. The hardware bypass network modules have built-in SFPs.

Hardware bypass is supported only on a fixed set of ports. You can pair Port 1 with Port 2, Port 3 with Port 4, but you cannot pair Port 1 with Port 4 for example.



Note When the appliance switches from normal operation to hardware bypass or from hardware bypass back to normal operation, traffic may be interrupted for several seconds. A number of factors can affect the length of the interruption; for example, behavior of the optical link partner such as how it handles link faults and debounce timing; spanning tree protocol convergence; dynamic routing protocol convergence; and so on. During this time, you may experience dropped connections.

There are three configuration options for hardware bypass network modules:

- **Passive interfaces**—Connection to a single port.
For each network segment you want to monitor passively, connect the cables to one interface. This is how the nonhardware bypass network modules operate.
- **Inline interfaces**—Connection to any two like ports (10 Gb to 10 Gb for example) on one network module, across network modules, or fixed ports.
For each network segment you want to monitor inline, connect the cables to pairs of interfaces.
- **Inline with hardware bypass interfaces**—Connection of a hardware bypass paired set.
For each network segment that you want to configure inline with fail-open, connect the cables to the paired interface set.

For the 40-Gb network module, you connect the two ports to form a paired set. For the 1/10-Gb network modules, you connect the top port to the bottom port to form a hardware bypass paired set. This allows traffic to flow even if the security appliance fails or loses power.



Note If you have an inline interface set with a mix of hardware bypass and nonhardware bypass interfaces, you cannot enable hardware bypass on this inline interface set. You can only enable hardware bypass on an inline interface set if all the pairs in the inline set are valid hardware bypass pairs.

For More Information

- See [1-Gb SX/10-Gb SR/10-Gb LR Network Module with Hardware Bypass](#), on page 23 for a description of the 1-G SX, 10-G SR, and LR network modules.
- See [1-Gb Network Module with Hardware Bypass](#), on page 26 for a description of the 1-G network module.
- See [Install, Remove, and Replace the Network Module](#), on page 63 for the procedure for removing and replacing single-wide network modules.

1-Gb SX/10-Gb SR/10-Gb LR Network Module with Hardware Bypass

The following figure shows the front panel of the 1-Gb SX, 10-Gb SR and 10-Gb LR hardware bypass network modules FPR2K-NM-6X1SX-F, FPR2K-NM-6X10SR-F, FPR2K-NM-6X10LR-F). This is a single-wide module that does *not* support hot swapping. The six ports are numbered from top to bottom, left to right. Pair ports 1 and 2, 3 and 4, and 5 and 6 to form hardware bypass paired sets.



Note Make sure you have the correct firmware package and software version installed to support this network module. See [Cisco FXOS Troubleshooting Guide for the Firepower 1000/2100 with Firepower Threat Defense](#) for the procedure to verify your firmware package and software version. See [Cisco Firepower 2100 ASA Platform Mode FXOS Configuration Guide](#) for the procedure to upgrade the firmware package for the Firepower 2100 running ASA with FXOS. See the [Cisco Firepower Compatibility Guide](#) and the [Cisco ASA Compatibility](#) guide, which provide Cisco software and hardware compatibility, including operating system and hosting environment requirements, for each supported version

Figure 17: FPR2K-NM-6X1SX-F, FPR2K-NM-6X10SR-F, FPR2K-NM-6X10LR-F

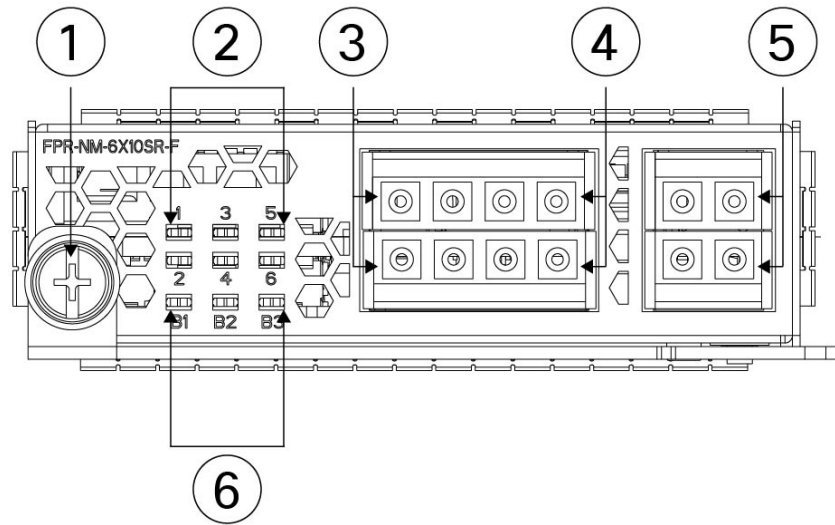

<p>1 Captive screw/handle</p>	<p>2 Six network activity LEDs:</p> <ul style="list-style-type: none"> • Amber—No connection, or port is not in use, or no link or network failure. • Green—Link up, no network activity. • Green, flashing—Network activity.
<p>3 Ethernet X/1 (top port) Ethernet X/2 (bottom port) Ports 1 and 2 are paired together to form a hardware bypass pair.</p>	<p>4 Ethernet X/3 (top port) Ethernet X/4 (bottom port) Ports 3 and 4 are paired together to form a hardware bypass pair.</p>
<p>5 Ethernet X/5 (top port) Ethernet X/6 (bottom port) Ports 5 and 6 are paired together to form a hardware bypass pair.</p>	<p>6 Bypass LEDs B1 through B3:</p> <ul style="list-style-type: none"> • Green—In standby mode. • Amber, flashing—Port is in hardware bypass mode, failure event.

The 1-Gb SX /10-Gb SR/10-Gb LR network modules have the following insertion loss measurements. Insertion loss measurements help you to troubleshoot the network by verifying cable installation and performance.

Table 2: 1-Gb SX Network Module (FPR2K-NM-6X1SX-F)

	Operating Mode	Typical	Maximum
Insertion loss	Normal	0.9 dB	1.4 dB
	Hardware bypass	1.2 dB	1.7 dB

	Core diameter (microns)	Modal bandwidth (MHz/km)	Cable distance Note Half the distance specified by the IEEE standard.
Cable and operating distance	62.5	160 (FDDI)	110 m
	62.5	200 (OM1)	137 m
	50	400	250 m
	50	500 (OM2)	275 m
	50	2000 (OM3)	500 m

Table 3: 10-Gb SR Network Module (FPR2K-NM-6X10SR-F)

	Operating Mode	Typical	Maximum
Insertion loss	Normal	0.9 dB	1.4 dB
	Hardware bypass	1.2 dB	1.7 dB
	Core diameter (microns)	Modal bandwidth (MHz/km)	Cable distance Note Half the distance specified by the IEEE standard.
Cable and operating distance	62.5	160 (FDDI)	13 m
	62.5	200 (OM1)	16.5 m
	50	400	33 m
	50	500 (OM2)	41 m
	50	2000 (OM3)	150 m
	50	4700 (OM4)	200 m

Table 4: 10-Gb LR Network Module (FPR2K-NM-6X10LR-F)

	Operating Mode	Typical	Maximum
Insertion loss	Normal	1.2 dB	1.6 dB
	Hardware bypass	1.5 dB	1.9 dB
	Core diameter (microns)	Modal bandwidth (MHz/km)	Cable distance Note Half the distance specified by the IEEE standard.

Cable and operating distance	G.652	Single mode	5 km
------------------------------	-------	-------------	------

1-Gb Network Module with Hardware Bypass

The following figure shows the front panel view of the 1-Gb network module with hardware bypass (FPR-NM-8X1G-F). Pair ports 1 and 2, 3 and 4, 5 and 6, and 7 and 8 to form hardware bypass paired sets.



Note Make sure you have the correct firmware package and software version installed to support this network module. See [Cisco FXOS Troubleshooting Guide for the Firepower 1000/2100 with Firepower Threat Defense](#) for the procedure to verify your firmware package and software version. See [Cisco Firepower 2100 ASA Platform Mode FXOS Configuration Guide](#) for the procedure to upgrade the firmware package for the Firepower 2100 running ASA with FXOS.

Figure 18: FPR-NM-8X1G-F

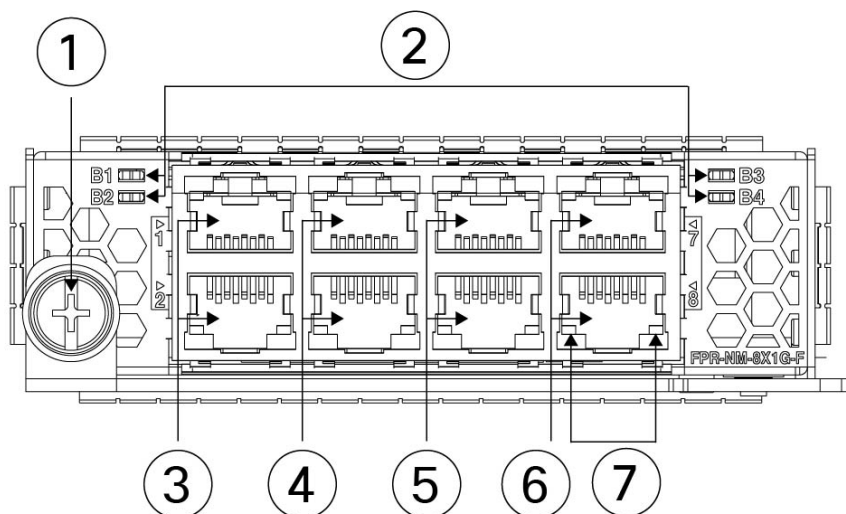

1	Captive screw/handle	2	Bypass LEDs B1 through B4 <ul style="list-style-type: none"> • Green—In standby mode. • Amber, flashing—Port is in hardware bypass mode, failure event.
3	Ethernet X/1 Ports 1 and 2 are paired together to form a hardware bypass pair. LED B1 applies to this paired port.	4	Ethernet X/2 Ports 3 and 4 are paired together to form a hardware bypass pair. LED B2 applies to this paired port.

5 Ethernet X/2 Ports 5 and 6 are paired together to form a hardware bypass pair. LED B3 applies to this paired port.	6 Ethernet X/2 Ports 7 and 8 are paired together to form a hardware bypass pair. LED B4 applies to this paired port.
7 Network activity LEDs <ul style="list-style-type: none"> • Left LED—Green indicates network activity when a 10M/100M/1G connection is made. • Right LED—Not in use at this time. 	—

Power Supply Modules

The Firepower 2110 and 2120 have one fixed AC power supply that is not field-replaceable. If the power supply fails, you must get a return material authorization (RMA) for the entire chassis. See the [Cisco Returns Portal](#) for more information.

The Firepower 2130 and 2140 support two AC power supply modules so that dual power supply redundancy protection is available. The Firepower 2130 ships with one AC power supply and the Firepower 2140 ships with two AC power supplies. You can also install DC power supply modules instead of AC power on the 2130 and 2140. Facing the back of the chassis, the power supply modules are numbered left to right, for example, PSU1 and PSU2.

The power supply module is hot-swappable.

See [Product ID Numbers, on page 34](#) for a list of the PIDs associated with the Firepower 2100 series power supply modules.



Note You *cannot* mix AC and DC power supply modules in the chassis.



Note After removing power from the chassis by unplugging the power cord, wait at least 10 seconds before turning power back ON.



Attention Make sure that one power supply module is always active.



Note The system power requirements are lower than the power supply module capabilities. See the following table.

AC Power Supply

The dual power supplies can supply up to 800-W power across the input voltage range. The load is shared when both power supply modules are plugged in and running at the same time.



Note The system does not consume more than the capacity of one power supply module, so it will always operate in full redundancy mode (Firepower 2130 and 2140 only) when two power supply modules are installed.

Table 5: AC Power Supply Module Hardware Specifications

	2110	2120	2130	2140
Input voltage	100 to 240 V AC			
Maximum input current	< 4 A		< 6 A	
Maximum output power	250 W		400 W	
Frequency	50 to 60 Hz			
Efficiency	85% at 50% load		89% at 50% load	
Maximum redundancy output power	—		800W	
Redundancy	—		1+1 redundancy with dual power supply modules	

DC Power Supply

The power supplies can supply up to 350 W power across the input voltage range. The load is shared when both power supply modules are plugged in and running at the same time.

Table 6: DC Power Supply Module Hardware Specifications

	2130	2140
Input voltage	-48 to -60 V DC	
Maximum input current	< 15 A at -48 V Note The power supply module is rated at 15 A but the system power is limited to 6.1 A. See Hardware Specifications, on page 33 for more system specifications.	
Maximum output power	350 W	
Redundancy	1+1 redundancy with dual power supply modules	
Efficiency	> 88% at 50% load	

Power Supply Module LEDs

The following figure shows the bicolor power supply LEDs on the power supply module. The figure shows the AC power supply module. The DC power supply module has the same LEDs.

Figure 19: Power Supply Module LEDs

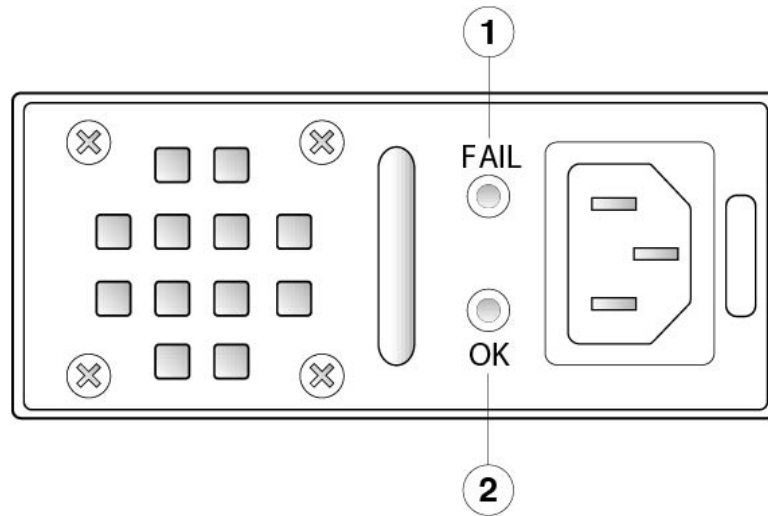

1	Amber FAIL LED	2	Green OK LED
----------	----------------	----------	--------------

The following describes the power module supply LEDs.

Green LED (OK Status)

- Off—Input power not present.
- Green, flashing—Input power present, but system is not powered up (power switch is off).
- Green—The power supply module is enabled and running.

Amber LED (Fail Status)

- Off—No fault detected.
- Amber, flashing—Fault warning, power supply may still work but could fail due to high temperature, failing fan, or over current.
- Amber—Fault detected; power supply not working properly. Includes over voltage, over current, over temperature, and fan failure.

For More Information

- See [Remove and Replace the Power Supply Module, on page 68](#) for the procedure for removing and replacing the power supply module in the Firepower 2130 and 2140.

Fan Modules

The Firepower 2110 and 2120 have two fixed fans. If the fans fail, you must send your Firepower 2110 or 2120 for RMA.

The Firepower 2130 and 2140 have a removable fan tray with 3 + 1 redundant fans that are hot-swappable. The fan tray is installed in the rear of the chassis. Any one fan can fail indefinitely and the system continues to function. When a fan fails, the remaining fans automatically spin up to full speed.

The fan LED is located on the front of the chassis. See [Product ID Numbers, on page 34](#) for a list of the PIDs associated with the 2100 series fans.

For More Information

- See [Front Panel LEDs, on page 12](#) for the location and description of the fan LED.
- See [Remove and Replace the Fan Tray, on page 78](#) for the procedure for removing and replacing the fan tray.

SSDs

The Firepower 2110 and 2120 have two SSD slots. These models ship with one 100-GB SSD installed in slot 1. The Firepower 2130 and 2140 have two SSD slots. These models ship with one 200-GB SSD installed in slot 1. See [Product ID Numbers, on page 34](#) for a list of the PIDs associated with the Firepower 2100 series SSDs. The SSD drive identifiers are `disk1` and `disk2`.

You can use the second SSD slot to upgrade to the MSP. The MSP *must* be installed in the second slot. The second SSD slot remains empty unless you install the MSP in the second slot. The MSP stores threat detection results for use in future analysis. It supports the Advanced Malware Protection (AMP) software feature. It is used as both storage and as the Malware application repository. RAID is not supported.



Caution You cannot swap SSDs between different Firepower platforms. For example, you cannot use a 4100 series SSD in a 2100 series chassis.



Note The 100-GB SSD is restricted to the Firepower 2110 and 2120 models. The 200-GB SSD is restricted to the Firepower 2130 and 2140 models. Do not mix them.

Although the hardware supports hot swapping for the SSDs, the software does not, so you must power down the chassis before removing and replacing them.

For More Information

- See [Front Panel LEDs, on page 12](#) for the location and description of the SSD LEDs on the front panel.
- See [Remove and Replace the SSD, on page 65](#) for the procedure for removing and replacing the SSD.

Supported SFP/SFP+ Transceivers

The SFP/SFP+ transceiver is a bidirectional device with a transmitter and receiver in the same physical package. It is a hot-swappable optical or electrical (copper) interface that plugs into the SFP/SFP+ ports on the fixed ports and the network module ports, and provides Ethernet connectivity.

Figure 20: SFP Transceiver

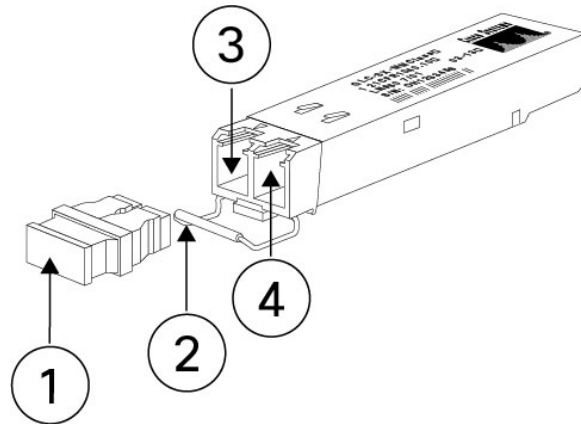

1	Dust plug	2	Bail clasp
3	Receive optical bore	4	Transmit optical bore

Safety Warnings

Take note of the following optical connection warnings:



Warning Statement 1051—Laser Radiation

Invisible laser radiation may be emitted from disconnected fibers or connectors. Do not stare into beams or view directly with optical instruments.



Warning Statement 1055—Class 1/1M Laser

Invisible laser radiation is present. Do not expose to users of telescopic optics. This applies to Class 1/1M laser products.





Warning Use appropriate ESD procedures when inserting the transceiver. Avoid touching the contacts at the rear, and keep the contacts and ports free of dust and dirt. Keep unused transceivers in the ESD packing that they were shipped in.



Note By default autonegotiation is enabled for 1-Gb fiber interfaces. In version 6.7 and later the ability to disable autonegotiation on 1-Gb fiber interfaces was added. This does not mean the interfaces can negotiate speed or support 10-M/100-M speeds. It means only that you can disable negotiation for a 1-Gb fiber interface. For example, you might disable negotiation if you are connecting to a tap type interface that cannot negotiate itself, because it might only receive and not transmit.



Caution Although non-Cisco SFPs are allowed, we do not recommend using them because they have not been tested and validated by Cisco. Cisco TAC may refuse support for any interoperability problems that result from using an untested third-party SFP transceiver.

The following table lists the supported transceivers.

Table 7: Supported SFPs

Optics Type	PID	Ports Supported
SFP 1Gb		
1G-SX	GLC-SX-MMD	Supported on Firepower 2110, 2120, 2130, and 2140 fixed ports (13 through 16).
1G-LH	GLC-LH-SMD	
1G-EX	GLC-EX-SMD	Supported on Firepower 2130 and 2140 ports 1 through 8 of the 8X1G network module.
1G-ZX	GLC-ZX-SMD	
1G 1000Base-T	GLC-T	Supported on all Firepower 2100 models.
1G 1000Base-T	GLC-TE	Supported on all Firepower 2100 models.
SFP+ 10Gb		

10G-SR	SFP-10G-SR	Supported on Firepower 2130 and 2140.
10G-LR	SFP-10G-LR	
10G-LRM	SFP-10G-LRM	
10G-ER	SFP-10G-ER	
10G-SR-S	SFP-10G-SR-S	
10G-LR-S	SFP-10G-LR-S	
10G-ZR-S	SFP-10G-ZR-S	
10G-ER-S	SFP-10G-ER-S	
H10GB-CU 1M, 1.5M, 2M, 2.5M, 3M, 5M	SFP-H10GB-CU1M SFP-H10GB-CU1-5M SFP-H10GB-CU2M SFP-H10GB-CU2-5 SFP-H10GB-CU3M SFP-H10GB-CU5M	
H10GB-ACU 7M, 10M	SFP-H10GB-ACU7M SFP-H10GB-ACU10M	
10G-AOC 1M, 2M, 3M, 5M, 7M, 10M	SFP-10G-AOC1M SFP-10G-AOC2M SFP-10G-AOC3M SFP-10G-AOC5M SFP-10G-AOC7M SFP-10G-AOC10M	

Hardware Specifications

The following table contains hardware specifications for the Firepower 2100 series.

Specification	2110	2120	2130	2140
Chassis dimensions (H x W x D)	1.73 x 16.90 x 19.76 inches (4.4 x 42.9 x 50.2 cm)			
Network module dimensions	1.2 x 3.7 x 9.6 inches (4.39 x 9.4 x 24.38)			
Weight	16.1 lb (7.3 kg)		19.4 lb (8.79 kg)	21 lb (9.52 kg)

Specification	2110	2120	2130	2140
System power	100/240V AC 1.9 A (at 100 VAC), 50 to 60 Hz Note The power supply module is rated at 4 A, but the system power is limited to 1.9 A.		100/240 V AC 2.9 A (at 100 VAC), 50 to 60 Hz Note The power supply module is rated at 6.3 A, but the system power is limited to 2.9 A.	
Temperature	Operating: 32 to 104°F (0 to 40°C) Nonoperating: -40 to 149°F (-40 to 65°C) maximum altitude is 40,000 ft			
NEBS	Operating altitude: 0 to 13,000 ft (3962 m) Operating temperature: <ul style="list-style-type: none"> • Long Term: 0 to 45°C up to 6000 ft (1829 m) • Long Term: 0 to 35°C 6000-13000 ft (1829-3964 m) • Short Term: -5 to 55°C up to 6000 ft (1829 m) Note Firepower 2100 series NEBS compliance applies only to the 2130.			
Humidity	Operating: 10 to 85 % noncondensing Nonoperating: 5 to 95 % noncondensing			
Altitude	Operating: 10,000 ft maximum Nonoperating: 40,000 ft maximum			
Sound pressure	47.3 dBA (typical) 73.4 dBA (maximum)		55.7 dBA (typical) 76.7 dBA (maximum)	
Sound power	60.2 (typical) 85.1 (maximum)		66 (typical) 84.5 (maximum)	

Product ID Numbers

The following table lists the PIDs associated with the Firepower 2100 series. All of the PIDs in the table are field-replaceable. If you need to get a return material authorization (RMA) for any component, see [Cisco Returns Portal](#) for more information.



Note See the **show inventory** and **show inventory expand** commands in the [Cisco FXOS Troubleshooting Guide for the Firepower 2100 Series](#) to display a list of the PIDs for your Firepower 2100. Or see the **show inventory** command in the [Cisco Firepower Threat Defense Command Reference](#) or the [Cisco ASA Series Command Reference](#) to display a list of the PIDs for your Firepower 2100.

Table 8: Firepower 2100 Series PIDs

PID	Description
FPR2110-NGFW-K9	Cisco Firepower 2110 NGFW appliance 1 RU
FPR2120-NGFW-K9	Cisco Firepower 2120 NGFW appliance 1 RU
FPR2130-NGFW-K9	Cisco Firepower 2130 NGFW appliance 1 RU with one network module bay
FPR2140-NGFW-K9	Cisco Firepower 2140 NGFW appliance 1 RU with one network module bay
FPR2110-ASA-K9	Cisco Firepower 2110 ASA appliance 1 RU
FPR2120-ASA-K9	Cisco Firepower 2120 ASA appliance 1 RU
FPR2130-ASA-K9	Cisco Firepower 2130 ASA appliance 1 RU with one network module bay
FPR2140-ASA-K9	Cisco Firepower 2140 ASA appliance 1 RU with one network module bay
FPR2110-K9=	Firepower 2110 appliance 1 RU with no power supply or fan (spare)
FPR2120-K9=	Firepower 2120 appliance 1 RU with no power supply or fan (spare)
FPR2130-K9=	Firepower 2130 appliance with one network module bay and no power supply or fan (spare)
FPR2140-K9=	Firepower 2140 appliance with one network module bay and no power supply or fan (spare)
FPR2K-PWR-DC-350	350 W DC power supply
FPR2K-PWR-DC-350=	350 W DC power supply (spare)
FPR2K-PWR-AC-400	400 W AC power supply
FPR2K-PWR-AC-400=	400 W AC power supply (spare)
FPR2K-PSU-BLANK	Power supply blank slot cover
FPR2K-PSU-BLANK=	Power supply blank slot cover (spare)
FPR2K-SSD100	SSD for Firepower 2110 and 2120
FPR2K-SSD100=	SSD for Firepower 2110 and 2120 (spare)
FPR2K-SSD200	SSD for Firepower 2130 and 2140
FPR2K-SSD200=	SSD for Firepower 2130 and 2140 (spare)

PID	Description
FPR2K-SSD-BBLKD	SSD slot carrier
FPR2K-SSD-BBLKD=	SSD slot carrier (spare)
FPR-MSP-SSD	MSP SSD
FPR-MSP-SSD=	MSP SSD (spare)
FPR2K-FAN	Fan tray for the Firepower 2130 and 2140
FPR2K-FAN=	Fan tray for the Firepower 2130 and 2140 (spare)
FPR2K-NM-8X1G	8-port 1-Gb SFP network module
FPR2K-NM-8X1G=	8-port 1-Gb SFP network module (spare)
FPR2K-NM-8X10G	8-port 10-Gb SFP+ network module
FPR2K-NM-8X10G=	8-port 10-Gb SFP+ network module (spare)
FPR2K-NM-6X1SX-F	6-port 1-Gb SX fiber hardware bypass network module
FPR2K-NM-6X1SX-F=	6-port 1-Gb SX fiber hardware bypass network module (spare)
FPR2K-NM-6X10LR-F	6-port 10-Gb LR hardware bypass network module
FPR2K-NM-6X10LR-F=	6-port 10-Gb LR hardware bypass network module (spare)
FPR2K-NM-6X10SR-F	6-port 10-Gb SR hardware bypass network module
FPR2K-NM-6X10SR-F=	6-port 10-Gb SR hardware bypass network module (spare)
FPR2K-NM-8X1G-F	8-port 1-Gb copper hardware bypass network module
FPR2K-NM-8X1G-F=	8-port 1-Gb copper hardware bypass network module (spare)
FPR2K-NM-BLANK	Network module blank slot cover
FPR2K-NM-BLANK=	Network module blank slot cover (spare)
FPR2K-CBL-MGMT	Cable management brackets
FPR2K-CBL-MGMT=	Cable management brackets (spare)
FPR2K-RM-BRKT=	Rack-mount brackets (spare)
FPR2K-SLIDE-RAILS	Slide rail kit
FPR2K-SLIDE-RAILS=	Slide rail kit (spare)

PID	Description
FPR2K-RAIL-BRKT=	Slide rail brackets (spare)

Power Cord Specifications

Each power supply has a separate power cord. Standard power cords or jumper power cords are available for connection to the security appliance. The jumper power cords for use in racks are available as an optional alternative to the standard power cords.

If you do not order the optional power cord with the system, you are responsible for selecting the appropriate power cord for the product. Using an incompatible power cord with this product may result in electrical safety hazard. Orders delivered to Argentina, Brazil, and Japan must have the appropriate power cord ordered with the system.



Note Only the approved power cords or jumper power cords provided with the security appliance are supported.

The following power cords are supported.

Figure 21: Argentina CAB-ACR

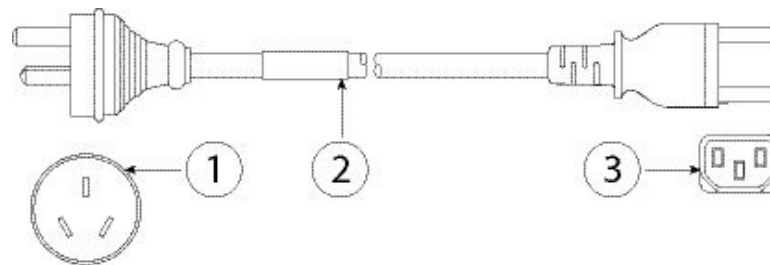

1	Plug: IRAM 2073	2	Cord set rating: 10 A, 250 V
3	Connector: IEC 60320/C13		

Figure 22: Australia CAB-ACA

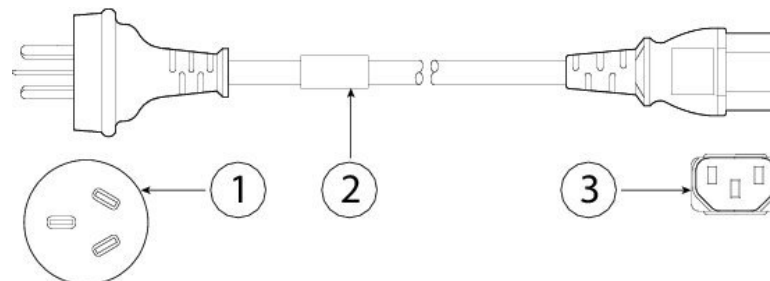

1	Plug: A.S. 3112	2	Cord set rating: 10 A, 250 V
3	Connector: IEC 60320/C13		

Figure 23: Brazil CAB-C13-ACB

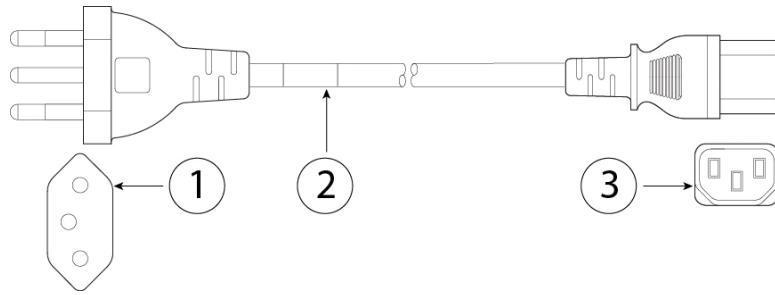

1	Plug: NBR 14136	2	Cord set rating: 10 A, 250 V
3	Connector: IEC 60320/C13		

Figure 24: China CAB-ACC

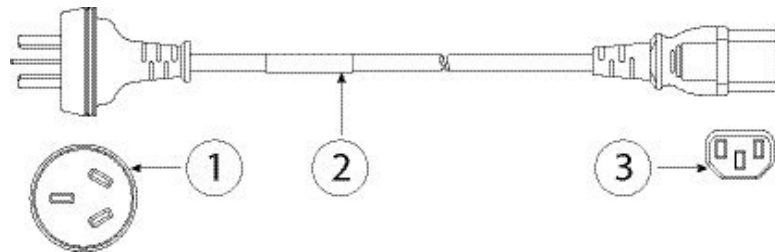

1	Plug: GB2099.1-2008/GB1002	2	Cord set rating: 10 A, 250 V
3	Connector: IEC 60320/C13		

Figure 25: Europe CAB-ACE

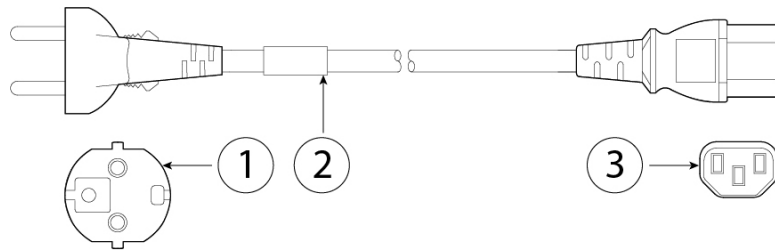

1	Plug: CEE 7 VII	2	Cord set rating: 10 A, 250 V
3	Connector: IEC 60320/C13		

Figure 26: India PWR-CORD-IND-D

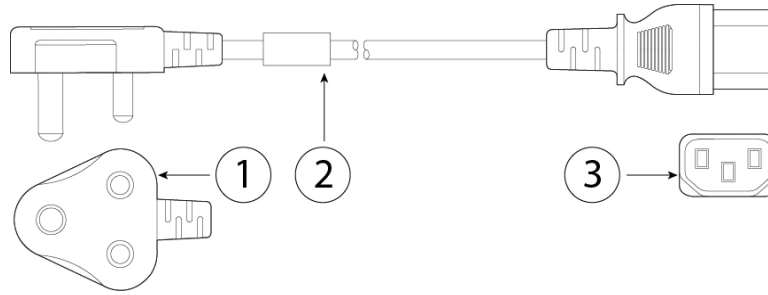

1	Plug: IS 6538-1971	2	Cord set rating: 10 A, 250 V
3	Connector: IEC 60320/C13		

Figure 27: Italy CAB-ACI

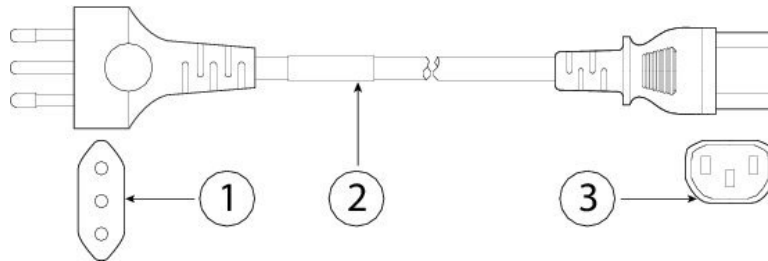

1	Plug: CEI 23-16	2	Cord set rating: 10 A, 250 V
3	Connector: IEC 60320/C13		

Figure 28: Japan CAB-JPN

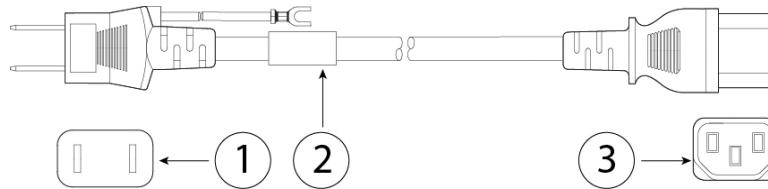

1	Plug: JIS C8303	2	Cord set rating: 12 A, 125 V
3	Connector: IEC 60320/C13		

Figure 29: Japan CAB-JPN-3PIN

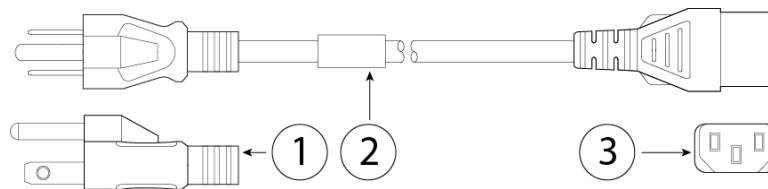

1	Plug: JIS C8303/JIS C8306	2	Cord set rating: 12 A, 125 V
3	Connector: IEC 60320/C13		

Figure 30: Jumper CAB-C13-C14-2M

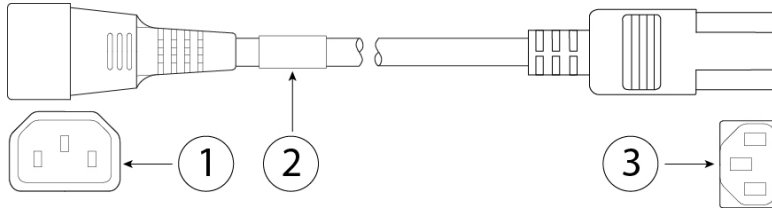

1	IEC 60320/C14G	2	Cord set rating: 10 A, 250 V
3	Connector: IEC 60320/C13		

Figure 31: Korea CAB-AC-C13-KOR

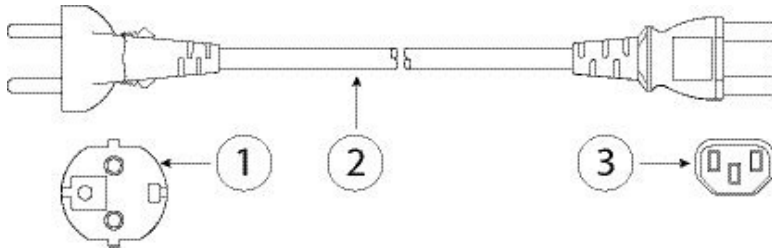

1	Plug: KSC 8305	2	Cord set rating: 10 A, 250 V
3	Connector: IEC 60320/C13		

Figure 32: North America CAB-AC

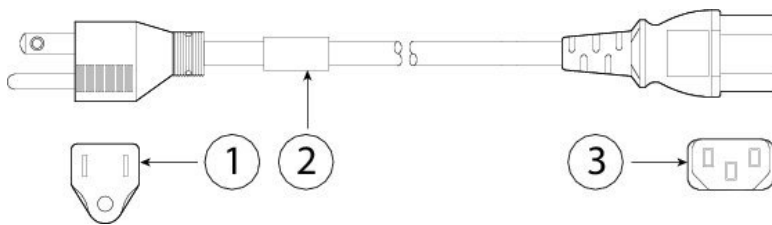

1	Plug: NEMA5-15P	2	Cord set rating: 10 A, 125 V
3	Connector: IEC 60320/C13		

Figure 33: South Africa CAB-ACSA

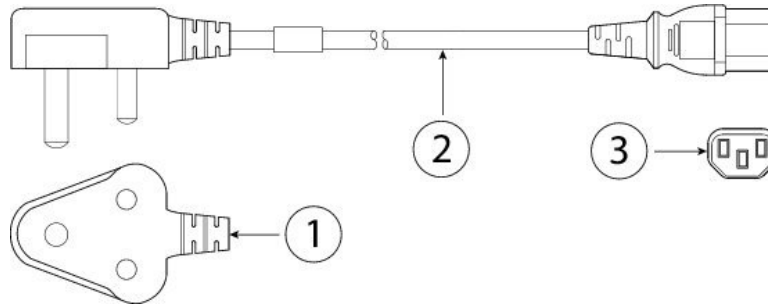

1	Plug: SABS 164	2	Cord set rating: 16 A, 250 V
3	Connector: IEC 60320/C13		

Figure 34: Switzerland CAB-ACS

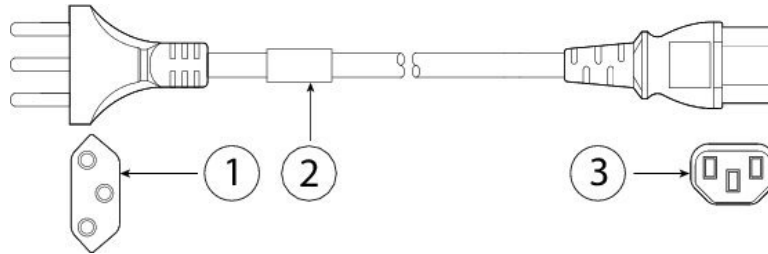

1	Plug: SEV 1011	2	Cord set rating: 10 A, 250 V
3	Connector: IEC 60320/C13		

Figure 35: Taiwan CAB-ACTW

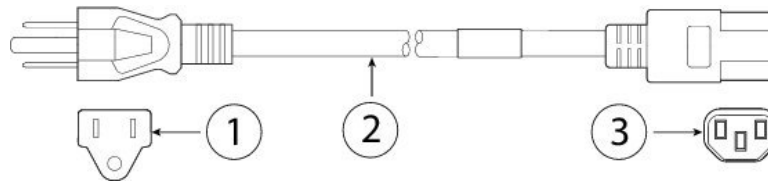

1	Plug: CNS10917	2	Cord set rating: 10 A, 125 V
3	Connector: IEC 60320/C13		

Figure 36: United Kingdom CAB-ACU

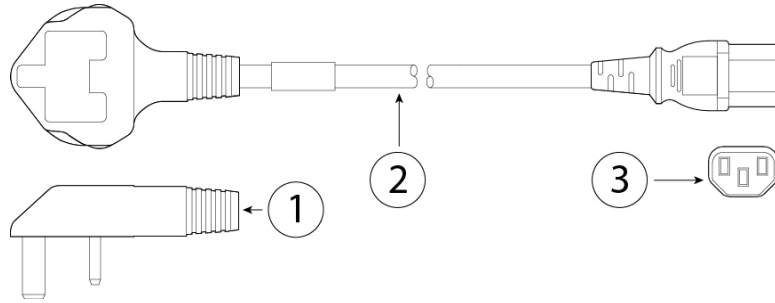

1	Plug: BS1363A/SS145	2	Cord set rating: 10 A, 250 V
3	Connector: IEC 60320/C13		



CHAPTER 2

Installation Preparation

- [General Safety Warnings](#), on page 43
- [Network Equipment-Building System \(NEBS\) Statements](#), on page 45
- [Safety Recommendations](#), on page 47
- [Maintain Safety with Electricity](#), on page 47
- [Prevent ESD Damage](#), on page 48
- [Site Environment](#), on page 48
- [Site Considerations](#), on page 48
- [Power Supply Considerations](#), on page 49
- [Rack Configuration Considerations](#), on page 49

General Safety Warnings

Read the [Regulatory Compliance and Safety Information](#) document before installing the security appliance.

Take note of the following general safety warnings:



Warning **Statement 1071**—Warning Definition

IMPORTANT SAFETY INSTRUCTIONS

Before you work on any equipment, be aware of the hazards involved with electrical circuitry and be familiar with standard practices for preventing accidents. Read the installation instructions before using, installing, or connecting the system to the power source. Use the statement number at the beginning of each warning statement to locate its translation in the translated safety warnings for this device.

SAVE THESE INSTRUCTIONS



**Note** **Statement 407**—Japanese Safety Instruction

You are strongly advised to read the safety instruction before using the product.

<https://www.cisco.com/web/JP/techdoc/pldoc/pldoc.html>

When installing the product, use the provided or designated connection cables/power cables/AC adapters.

〈製品仕様における安全上の注意〉
www.cisco.com/web/JP/techdoc/index.html

接続ケーブル、電源コードセット、ACアダプタ、バッテリーなどの部品は、必ず添付品または指定品をご使用ください。添付品・指定品以外をご使用になると故障や動作不良、火災の原因となります。また、電源コードセットは弊社が指定する製品以外の電気機器には使用できないためご注意ください。

**Warning** **Statement 1015**—Battery Handling

To reduce risk of fire, explosion or leakage of flammable liquid or gas:

- Replace the battery only with the same or equivalent type recommended by the manufacturer.
- Do not dismantle, crush, puncture, use sharp tool to remove, short external contacts, or dispose of in fire.
- Do not use if battery is warped or swollen.
- Do not store or use battery in a temperature > 60° C.
- Do not store or use battery in low air pressure environment < 69.7 kPa.

**Warning** **Statement 1029**—Blank Faceplates and Cover Panels

Blank faceplates and cover panels serve three important functions: they reduce the risk of electric shock and fire, they contain electromagnetic interference (EMI) that might disrupt other equipment, and they direct the flow of cooling air through the chassis. Do not operate the system unless all cards, faceplates, front covers, and rear covers are in place.

**Warning** **Statement 1073**—No User-Serviceable Parts

There are no serviceable parts inside. To avoid risk of electric shock, do not open.

**Warning** **Statement 1074**—Comply with Local and National Electrical Codes

To reduce risk of electric shock or fire, installation of the equipment must comply with local and national electrical codes.

**Warning Statement 1089—Instructed and Skilled Person Definitions**

An instructed person is someone who has been instructed and trained by a skilled person and takes the necessary precautions when working with equipment.

A skilled person or qualified personnel is someone who has training or experience in the equipment technology and understands potential hazards when working with equipment.

There are no serviceable parts inside. To avoid risk of electric shock, do not open.

**Warning Statement 1090—Installation by Skilled Person**

Only a skilled person should be allowed to install, replace, or service this equipment. See statement 1089 for the definition of a skilled person.

There are no serviceable parts inside. To avoid risk of electric shock, do not open.

**Warning Statement 1091—Installation by an Instructed Person**

Only an instructed person or skilled person should be allowed to install, replace, or service this equipment. See statement 1089 for the definition of an instructed or skilled person.

There are no serviceable parts inside. To avoid risk of electric shock, do not open.

**Warning Statement 9001—Product Disposal**

Ultimate disposal of this product should be handled according to all national laws and regulations.

Network Equipment-Building System (NEBS) Statements

NEBS describes the environment of a typical United States Regional Bell Operating Company (RBOC) central office. NEBS is the most common set of safety, spatial, and environmental design standards applied to telecommunications equipment in the United States. It is not a legal or regulatory requirement, but rather an industry requirement.

The following NEBS statements apply to the Firepower 2130:

**Note Statement 7001—ESD Mitigation**

This equipment may be ESD sensitive. Always use an ESD ankle or wrist strap before handling equipment. Connect the equipment end of the ESD strap to an unfinished surface of the equipment chassis or to the ESD jack on the equipment if provided.



Warning **Statement 7003**—Shielded Cable Shielded Cable Requirements for Intrabuilding Lightning Surge

The intrabuilding port(s) of the equipment or subassembly must use shielded intrabuilding cabling/wiring that is grounded at both ends.

The following port(s) are considered intrabuilding ports on this equipment:

Gigabit Ethernet management port

RJ-45 1 G/100 M/10 M auto duplex/auto MDI-X Base-T ports



Note **Statement 7004**—Special Accessories Required to Comply with GR-1089 Emission and Immunity Requirements

To comply with the emission and immunity requirements of GR-1089, shielded cables are required for the following ports:

Gigabit Ethernet management port

RJ-45 1 G/100 M/10 M auto duplex/auto MDI-X Base-T ports



Warning **Statement 7005**—Intrabuilding Lightning Surge and AC Power Fault

The intrabuilding port(s) of the equipment or subassembly must not be metallically connected to interfaces that connect to the outside plant (OSP) or its wiring. These interfaces are designed for use as intrabuilding interfaces only (Type 2 or Type 4 ports as described in GR-1089-CORE) and require isolation from the exposed OSP cabling. The addition of primary protectors is not sufficient protection to connect these interfaces metallically to OSP wiring.

This statement applies to the intrabuilding ports listed below:

Gigabit Ethernet management port

RJ-45 1 G/100 M/10 M auto duplex/auto MDI-X Base-T ports



Warning **Statement 7012**—Equipment Interfacing with AC Power Ports

Connect this equipment to AC mains that are provided with a surge protective device (SPD) at the service equipment that complies with NFPA 70, the National Electrical Code (NEC).



Note **Statement 7013**—Equipment Grounding Systems—Common Bonding Network (CBN)

This equipment is suitable for installations using the CBN.



Note **Statement 7016**—Battery Return Conductor

Treat the battery return conductor of this equipment as DC-I.



Note **Statement 7018**—System Recover Time

The equipment is designed to boot up in less than 30 minutes provided the neighboring devices are fully operational.



Note **Statement 8015**—Installation Location Network Telecommunications Facilities

This equipment is suitable for installation in network telecommunications facilities.



Note **Statement 8016**—Installation Location Where the National Electric Code (NEC) Applies

This equipment is suitable for installation in locations where the NEC applies.

Safety Recommendations

Observe these safety guidelines:

- Keep the area clear and dust-free before, during, and after installation.
- Keep tools away from walkways, where you and others might trip over them.
- Do not wear loose clothing or jewelry, such as earrings, bracelets, or chains that could get caught in the chassis.
- Wear safety glasses if you are working under any conditions that might be hazardous to your eyes.
- Do not perform any action that creates a potential hazard to people or makes the equipment unsafe.
- Never attempt to lift an object that is too heavy for one person.

Maintain Safety with Electricity



Warning Before working on a chassis, be sure the power cord is unplugged.

Read the document before installing the security appliance.

Follow these guidelines when working on equipment powered by electricity:

- Before beginning procedures that require access to the interior of the chassis, locate the emergency power-off switch for the room in which you are working. Then, if an electrical accident occurs, you can act quickly to turn off the power.
- Do not work alone if potentially hazardous conditions exist anywhere in your work space.
- Never assume that power is disconnected; always check.
- Look carefully for possible hazards in your work area, such as moist floors, ungrounded power extension cables, frayed power cords, and missing safety grounds.
- Use the chassis within its marked electrical ratings and product usage instructions.

Prevent ESD Damage

ESD occurs when electronic components are improperly handled, and it can damage equipment and impair electrical circuitry, resulting in intermittent or complete failure.

Always follow ESD-prevention procedures when removing and replacing components. Ensure that the chassis is electrically connected to an earth ground. Wear an ESD-preventive wrist strap, ensuring that it makes good skin contact. Connect the grounding clip to an unpainted surface of the chassis frame to safely ground ESD voltages. To properly guard against ESD damage and shocks, the wrist strap and cord must operate effectively. If no wrist strap is available, ground yourself by touching the metal part of the chassis.

For safety, periodically check the resistance value of the antistatic strap, which should be between one and 10 megohms.

Site Environment

See [Hardware Specifications, on page 33](#) for information about physical specifications.

When planning the site layout and equipment locations, consider the information in the next sections to help avoid equipment failures and reduce the possibility of environmentally caused shutdowns. If you are currently experiencing shutdowns or unusually high error rates with your existing equipment, these considerations may help you isolate the cause of failures and prevent future problems.

Site Considerations

Considering the following helps you plan an acceptable operating environment for the chassis, and avoid environmentally caused equipment failures.

- Electrical equipment generates heat. Ambient air temperature might not be adequate to cool equipment to acceptable operating temperatures without adequate circulation. Ensure that the room in which you operate your system has adequate air circulation.
- Ensure that the chassis cover is secure. The chassis is designed to allow cooling air to flow effectively within it. An open chassis allows air leaks, which may interrupt and redirect the flow of cooling air from the internal components.
- Always follow the ESD-prevention procedures described previously to avoid damage to equipment. Damage from static discharge can cause immediate or intermittent equipment failure.

Power Supply Considerations

See [Power Supply Modules, on page 27](#) for more detailed information about the power supply modules for your model.

When installing the chassis, consider the following:

- Check the power at the site before installing the chassis to ensure that it is “clean” (free of spikes and noise). Install a power conditioner, if necessary, to ensure proper voltages and power levels in the appliance input voltage.
- Install proper grounding for the site to avoid damage from lightning and power surges.
- The chassis does not have a user-selectable operating range. Refer to the label on the chassis for the correct appliance input-power requirement.
- Several styles of AC-input power supply cords are available; make sure that you have the correct style for your site.
- Install an uninterruptible power source for your site, if possible.
- If you are using dual redundant (1+1) power supplies, we recommend that you use independent electrical circuits for each power supply.

Rack Configuration Considerations

See [Rack-Mount the Chassis Using Slide Rails, on page 55](#) and [Rack-Mount the Chassis Using Brackets, on page 52](#) for the procedure for rack-mounting the chassis.

Consider the following when planning a rack configuration:

- Standard 19-in. (48.3 cm) 4-post EIA rack with mounting rails that conform to English universal hole spacing according to section 1 of ANSI/EIA-310-D-1992.
- The rack-mounting posts need to be 2 to 3.5 mm thick to work with the slide rail rack mounting.
- If you are mounting a chassis in an open rack, make sure that the rack frame does not block the intake or exhaust ports.
- If your rack includes closing front and rear doors, the doors must have 65 percent open perforated area evenly distributed from top to bottom to permit adequate airflow.
- Be sure enclosed racks have adequate ventilation. Make sure that the rack is not overly congested as each chassis generates heat. An enclosed rack should have louvered sides and a fan to provide cooling air.
- In an enclosed rack with a ventilation fan in the top, heat generated by equipment near the bottom of the rack can be drawn upward and into the intake ports of the equipment above it in the rack. Ensure that you provide adequate ventilation for equipment at the bottom of the rack.
- Baffles can help to isolate exhaust air from intake air, which also helps to draw cooling air through the chassis. The best placement of the baffles depends on the airflow patterns in the rack. Experiment with different arrangements to position the baffles effectively.



CHAPTER 3

Rack-Mount and Ground the Chassis

- [Unpack and Inspect the Chassis, on page 51](#)
- [Rack-Mount the Chassis Using Brackets, on page 52](#)
- [Rack-Mount the Chassis Using Slide Rails, on page 55](#)
- [Ground the Chassis, on page 60](#)

Unpack and Inspect the Chassis



Tip Keep the shipping container in case the chassis requires shipping in the future.



Note The chassis is thoroughly inspected before shipment. If any damage occurred during transportation or any items are missing, contact your customer service representative immediately.

See [Package Contents, on page 5](#) for a list of what shipped with the chassis.

- Step 1** Remove the chassis from its cardboard container and save all packaging material.
- Step 2** Compare the shipment to the equipment list provided by your customer service representative. Verify that you have all items.
- Step 3** Check for damage and report any discrepancies or damage to your customer service representative. Have the following information ready:
- Invoice number of shipper (see the packing slip)
 - Model and serial number of the damaged unit
 - Description of damage
 - Effect of damage on the installation
-

Rack-Mount the Chassis Using Brackets

This procedure describes how to install the Firepower 2100 in a rack using the rack-mount brackets. It also describes how to install the optional cable management brackets. See [Product ID Numbers, on page 34](#) for a list of the PIDs associated with rack-mounting the chassis.

The rack is a standard Electronic Industries Association (EIA) rack. It is a 4-post-EIA-310-D, which is the current revision as specified by EIA. The vertical hole spacing alternates at .50 inches (12.70 mm) to .625 inches (15.90 mm) to .625 inches (15.90 mm) and repeats. The start and stop space is in the middle of the .50-inch holes. The horizontal spacing is 18.312 inches (465.1 mm), and the rack opening is specified as a minimum of 17.75 inches (450 mm).

You need the following to install the Firepower 2100 in a rack:

- Phillips screwdriver
- Two rack-mount brackets (part number 700-106374-01) with six 8-32 x 0.281-inch screws (part number 48-101518-01)



Note The rack-mount brackets ship with the Firepower 2110 and 2120 and are orderable for the Firepower 2130 and 2140.

- Rack-mount screws:



Note The rack-mount screws ship with the Firepower 2110 and 2120 and are orderable for the Firepower 2130 and 2140.

- Four 12-24 x 0.75-inch Phillips screws (part number 648-0440-01) for securing the chassis to your rack
- Four 10-32 x 0.75-inch Phillips screws (part number 48-0441-01) for securing the chassis to your rack
- Four M6 x 1 x 19-mm Phillips screws (part number 48-101022-01) for securing the chassis to your rack
- (Optional) Cable management bracket kit (part number 69-100376-01):
 - Two cable management brackets (part number 700-106377-01)
 - Four 8-32 x 0.375-inch Phillips screws (part number 48-2696-01)

Safety Warnings

Take note of the following rack-mount safety warnings:



Warning Statement 1006—Chassis Warning for Rack-Mounting and Servicing

To prevent bodily injury when mounting or servicing this unit in a rack, you must take special precautions to ensure that the system remains stable. The following guidelines are provided to ensure your safety:

- This unit should be mounted at the bottom of the rack if it is the only unit in the rack.
 - When mounting this unit in a partially filled rack, load the rack from the bottom to the top with the heaviest component at the bottom of the rack.
 - If the rack is provided with stabilizing devices, install the stabilizers before mounting or servicing the unit in the rack.
-



Warning Statement 1032—Lifting the Chassis

To prevent personal injury or damage to the chassis, never attempt to lift or tilt the chassis using the handles on modules, such as power supplies, fans, or cards. These types of handles are not designed to support the weight of the unit.



Warning Statement 1098—Lifting Requirement

Two people are required to lift the heavy parts of the product. To prevent injury, keep your back straight and lift with your legs, not your back.

Step 1 Attach a rack-mount bracket to each side of the chassis using the six 8-32 x 0.281-inch Phillips screws (three per side).

Figure 37: Attach the Rack-Mount Bracket to the Side of the Chassis

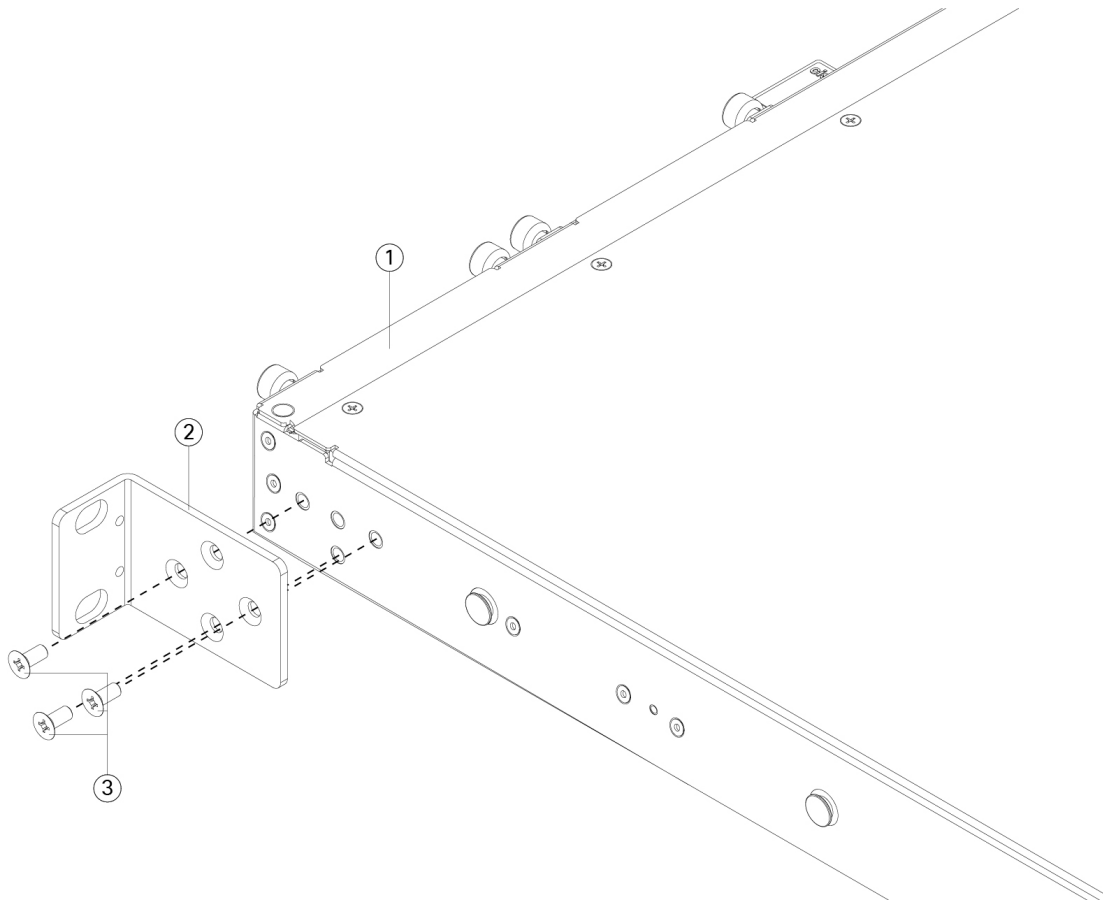

1	Chassis	2	Rack-mount bracket
3	8-32 x 0.281-inch Phillips screws (three per side)		

- Step 2** (Optional) Attach the cable management bracket to the rack-mount bracket:
- a) Install the cable management screws into the rack-mount bracket.

Figure 38: Install the Cable Management Screws into the Rack-Mount Bracket

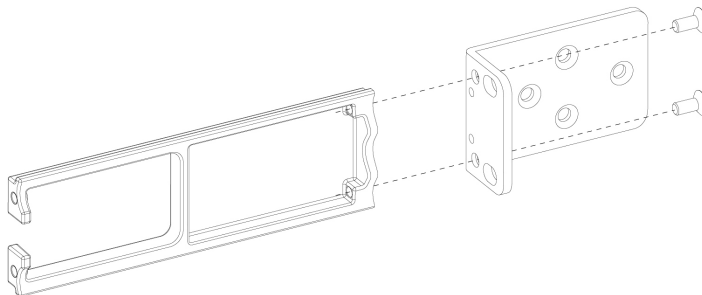

- b) Install two 8-32 x 0.375-inch screws through the inside of each rack-mount bracket to secure the cable management bracket to the rack-mount bracket.

Step 3

Attach the chassis with the installed rack-mount bracket to the rack using the screws that work for your rack.

What to do next

- See [Ground the Chassis, on page 60](#) for the procedure to ground the Firepower 2100.
- Install the cables according to your default software configuration as described in the [Cisco Firepower Getting 2100 Started Guide](#).

Rack-Mount the Chassis Using Slide Rails

This procedure describes how to install the Firepower 2100 series in a rack using slide rails. It applies to all models of the 2100 series. It ships with the Firepower 2130 and 2140 chassis; it is optional for the 2110 and 2120. For the 2110 and 2120, you install three screws on the chassis to secure the slide rail. For the 2130 and 2140, you use the pegs on the chassis to secure the slide rail. See [Product ID Numbers, on page 34](#) for a list of the PIDs associated with racking the chassis.

You can install the optional cable management bracket on all models of the 2100 series. The optional cable management bracket kit comes with two cable management brackets and four 8-32 x 0.375-inch screws.

The rack is a standard Electronic Industries Association (EIA) rack. It is a 4-post-EIA-310-D, which is the current revision as specified by EIA. The vertical hole spacing alternates at .50 inches (12.70 mm) to .625 inches (15.90 mm) to .625 inches (15.90 mm) and repeats. The start and stop space is in the middle of the .50-inch holes. The horizontal spacing is 18.312 inches (465.1 mm), and the rack opening is specified as a minimum of 17.75 inches (450 mm).

You need the following to install the Firepower 2100 in a rack using slide rails:

- Phillips screwdriver
- One slide rail kit (part number 800-103711-01) that contains the following:



Note The slide rail kit ships with the Firepower 2130 and 2140. You can order it for the Firepower 2110 and 2120.

- Left and right slides rails with two M3 x 6-mm Phillips screws (part number 48-101144-01)
- Two slide rail locking brackets (700-105350-02) with six 8-32 x 0.25-inch Phillips screws (part number 48-101429-01)
- (Optional) Two cable management brackets (part number 700-106377-01) with four 8-32 x 0.375-inch Phillips screws (part number 48-2696-01)

Slide rail assemblies work with four-post racks and cabinets with square slots, round 7.1mm holes, #10-32 threaded holes, and #12-24 threaded holes on the rack post front. The slide rail works with front to back spacing of rack posts from 24 to 36 inches. The rack-mounting posts need to be 2 to 3.5-mm thick to work with the slide rail rack mounting.

Safety Warnings

Take note of the following rack-mount safety warnings:



Warning Statement 1006—Chassis Warning for Rack-Mounting and Servicing

To prevent bodily injury when mounting or servicing this unit in a rack, you must take special precautions to ensure that the system remains stable. The following guidelines are provided to ensure your safety:

- This unit should be mounted at the bottom of the rack if it is the only unit in the rack.
 - When mounting this unit in a partially filled rack, load the rack from the bottom to the top with the heaviest component at the bottom of the rack.
 - If the rack is provided with stabilizing devices, install the stabilizers before mounting or servicing the unit in the rack.
-



Warning Statement 1032—Lifting the Chassis

To prevent personal injury or damage to the chassis, never attempt to lift or tilt the chassis using the handles on modules, such as power supplies, fans, or cards. These types of handles are not designed to support the weight of the unit.



Warning Statement 1047—Overheating Prevention

To reduce the risk of fire or bodily injury, do not operate the unit in an area that exceeds the maximum recommended ambient temperature of 104°F (40°C).



Warning Statement 1098—Lifting Requirement

Two people are required to lift the heavy parts of the product. To prevent injury, keep your back straight and lift with your legs, not your back.

Step 1

(Optional) Attach the cable management bracket to the slide-rail locking bracket by installing two 8-32 x 0.375-inch Phillips screws through the inside of the slide-rail locking bracket into the cable management bracket. Repeat for the second cable management bracket.

Figure 39: Install the Cable Management Bracket Screws into the Slide-Rail Locking Bracket

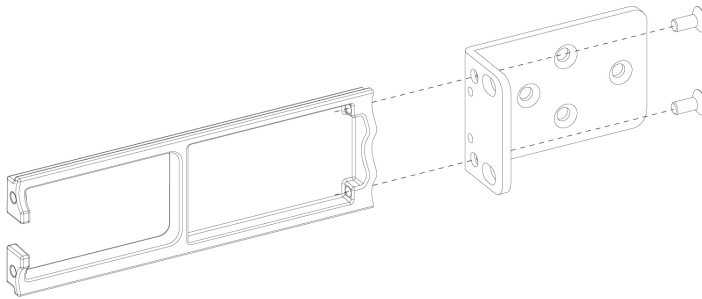

Step 2 Attach the slide-rail locking brackets to each side of the chassis using the six 8-32 x 0.375-inch Phillips screws (three per side).

Figure 40: Attach the Slide-Rail Locking Bracket to the Side of the Chassis

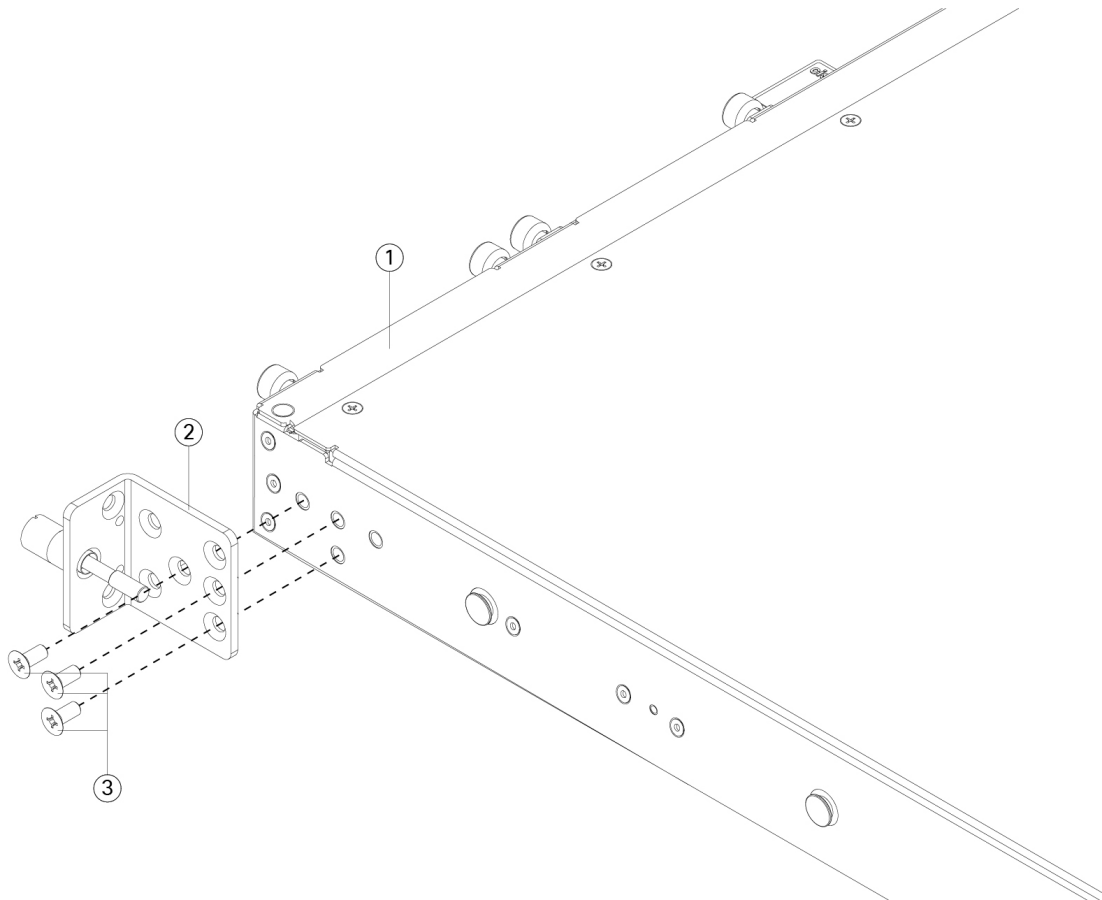

1	Chassis	2	Slide-rail locking bracket
3	8-32 x 0.25-inch Phillips screws (three per side)		—

Step 3

Attach the inner rails to the sides of the chassis:

- a) Remove the inner rails from the slide rail assemblies.
- b) Align an inner rail with each side of the chassis:
 - For the Firepower 2110 and 2120, install three 8-32 x 0.25-inch Phillips screws into each side of the chassis, and align the inner rail so that the three slots on the rail line up with the screws on the chassis.

Figure 41: Line up the Inner Rail and Install the Screws on the 2110 and 2120 Chassis

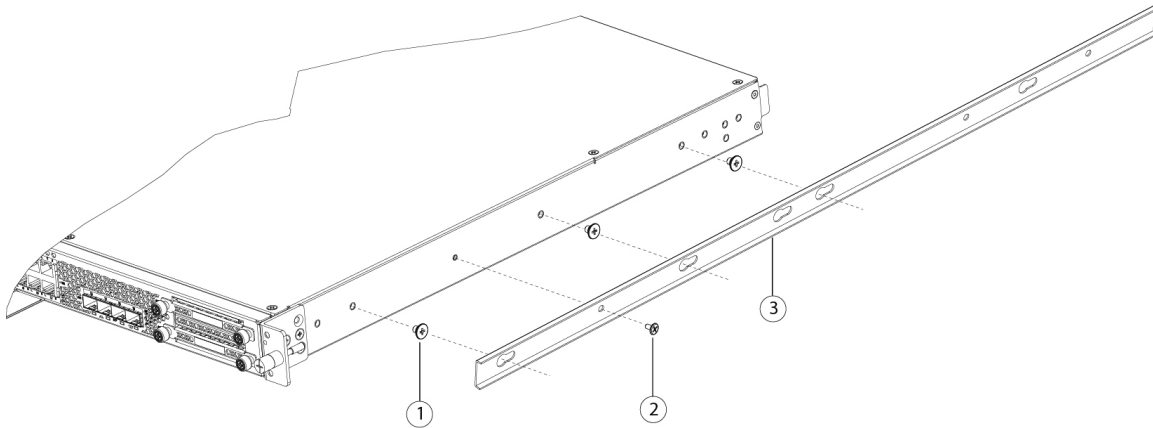

1	8-32 x 0.25-inch Phillips screws (3 per side)	2	M3 x 6 mm-Phillips screw (one per side)
3	Inner rail		—

- For the Firepower 2130 and 2140, align the inner rail so that the three slots on the rail line up with the three pegs on the side of the chassis.

Figure 42: Line up the Inner Rail with the Pegs on the 2130 and 2140 Chassis

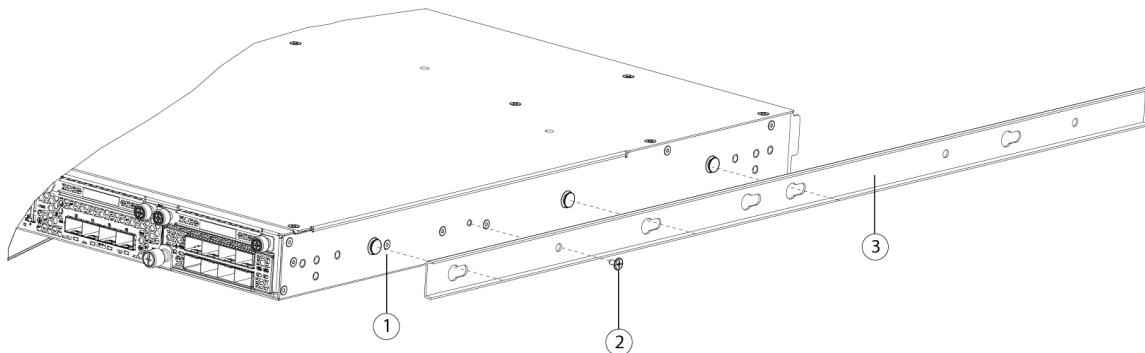

1	Mounting peg on the chassis for the keyed slot	2	M3 x 6 mm-Phillips screw (one per side)
3	Inner rail		—

- c) Set the keyed slots over the screws/pegs, and then slide the rail toward the front to lock it in place on the screw/pegs. The rear key slot has a metal clip that locks over the screw/peg.
- d) Using one M3 x 6-mm Phillips screw, secure the inner rail to the side of the chassis to prevent sliding.
- e) Install the second inner rail to the opposite side of the chassis and secure with the other M3 x 6-mm screw.

Step 4 Open the front securing plate on both slide-rail assemblies. The front end of the slide-rail assembly has a spring-loaded securing plate that must be open before you can insert the mounting pegs into the rack-post holes.

On the outside of the assembly, push the green arrow button toward the rear to open the securing plate.

Figure 43: Front Securing Mechanism Inside the Front End

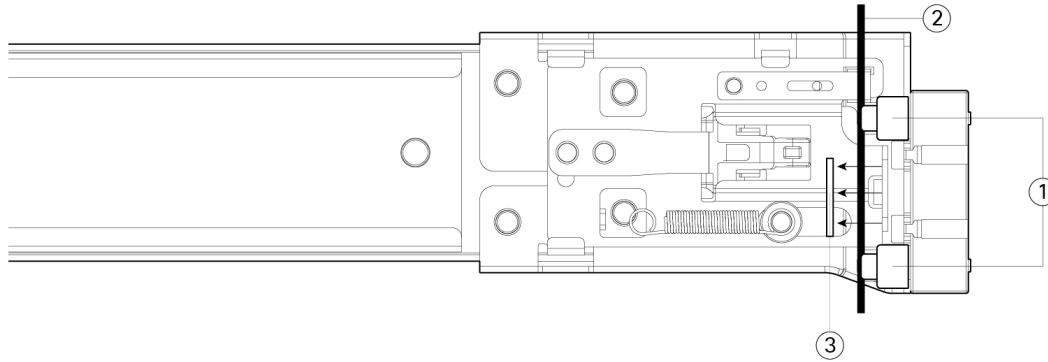

1	Front mounting pegs Note Works with square slots, 7.1 mm holes, and 10-32 threaded holes.	2	Securing plate shown pulled back to open position
3	Rack post	—	—

Step 5 Install the slide rails into the rack:

- a) Align one slide-rail assembly front end with the front rack-post holes that you want to use.

The slide rail front-end wraps around the outside of the rack post and the mounting pegs enter the rack-post holes from the outside-front.

Note The rack post must be between the mounting pegs and the open securing plate.

- b) Push the mounting pegs into the rack-post holes from the outside-front.
- c) Press the securing plate release button marked 'PUSH.' The spring-loaded securing plate closes to lock the pegs in place.
- d) Adjust the slide-rail length, and then push the rear mounting pegs into the corresponding rear rack-post holes. The slide rail must be level front-to-rear.

The rear mounting pegs enter the rear rack-post holes from the inside of the rack post.

- e) Attach the second slide-rail assembly to the opposite side of the rack. Make sure that the two slide-rail assemblies are at the same height with each other and are level front-to-back.
- f) Pull the inner slide rails on each assembly out toward the rack front until they hit the internal stops and lock in place.

Step 6 Insert the chassis into the slide rails.

- a) Align the rear of the inner rails that are attached to the chassis sides with the front ends of the empty slide rails on the rack.
- b) Push the inner rails into the slide rails on the rack until they stop at the internal stops.

- c) Slide the release clip toward the rear on both inner rails, and then continue pushing the chassis into the rack until the mounting brackets meet the front of the slide rail.

Figure 44: Inner Rail Release Clip

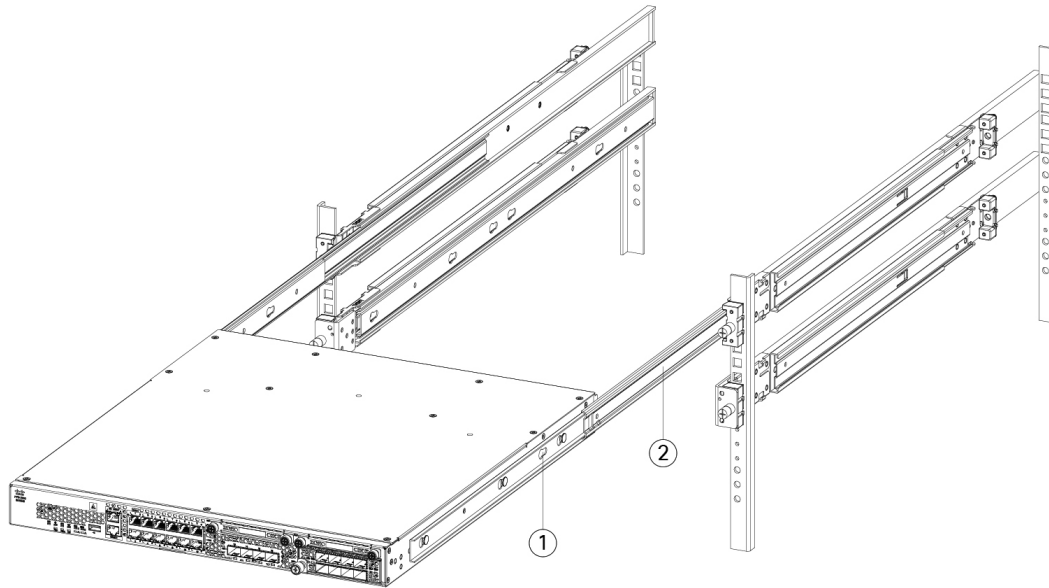

1	Inner rail release clip	2	Inner rail attached to chassis
---	-------------------------	---	--------------------------------

- Step 7** Use the captive screws on the front of the mounting brackets to fully secure the chassis to the rack.

What to do next

- See [Ground the Chassis, on page 60](#) for the procedure to ground the Firepower 2100.
- Install the cables according to your software configuration as described in the [Cisco Firepower 2100 Getting Started Guide](#).

Ground the Chassis



Note Grounding the chassis is required, even if the rack is already grounded. A grounding pad with two threaded M4 holes is provided on the chassis for attaching a grounding lug. The grounding lug must be Nationally Recognized Testing Laboratory (NRTL)-listed. In addition, a copper conductor (wires) must be used and the copper conductor must comply with National Electrical Code (NEC) code for ampacity.

You need the following items that you provide:

- Wire-stripping tool
- Crimping tool
- Grounding cable
- Two star lock washers for the 10-32 x 0.375-inch screws used to secure the ground lug
- You need the following items from the accessory kit:
 - Grounding lug #6 AWG, 90 degree, #10 post
 - Two 10-32 x 0.375-inch screws used to secure the grounding lug

Safety Warnings

Take note of the following ground connection warnings:



Warning Statement 1024—Ground Conductor

This equipment must be grounded. To reduce the risk of electric shock, never defeat the ground conductor or operate the equipment in the absence of a suitably installed ground conductor. Contact the appropriate electrical inspection authority or an electrician if you are uncertain that suitable grounding is available.

- Step 1** Use a wire-stripping tool to remove approximately 0.75 inches (19 mm) of the covering from the end of the grounding cable.
- Step 2** Insert the stripped end of the grounding cable into the open end of the grounding lug.

Figure 45: Insert the Cable into the Grounding Lug

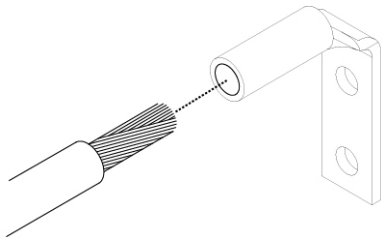

- Step 3** Use the crimping tool to secure the grounding cable in the grounding lug.
- Step 4** Remove the adhesive label from the grounding pad on the chassis.
- Step 5** Place the grounding lug against the grounding pad so that there is solid metal-to-metal contact, and insert the two screws with washers through the holes in the grounding lug and into the grounding pad.

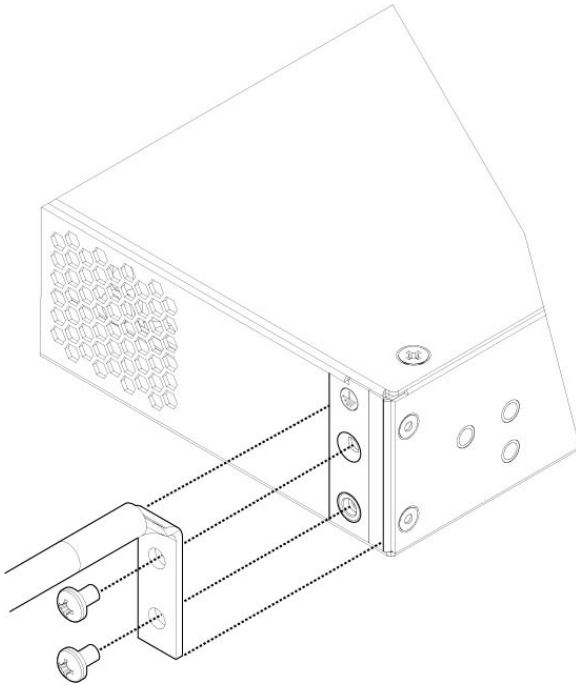
Figure 46: Attach the Grounding Lug

Step 6 Make sure that the lug and cable do not interfere with other equipment.

Step 7 Prepare the other end of the grounding cable and connect it to an appropriate grounding point in your site to ensure adequate earth ground.

What to do next

Install the FIPS opacity shield if necessary. See [Install the FIPS Opacity Shield in a Two-Post Rack, on page 80](#) and [Install the FIPS Opacity Shield in a Four-Post Rack, on page 83](#) for the procedure.

Install the cables according to your default software configuration as described in the [Cisco Firepower 2100 Getting Started Guide](#).



CHAPTER 4

Installation, Maintenance, and Upgrade

- [Install, Remove, and Replace the Network Module, on page 63](#)
- [Remove and Replace the SSD, on page 65](#)
- [Remove and Replace the Power Supply Module, on page 68](#)
- [Connect the DC Power Supply Module, on page 71](#)
- [Secure the Power Cord on the Power Supply Module, on page 75](#)
- [Remove and Replace the Fan Tray, on page 78](#)
- [Install the FIPS Opacity Shield in a Two-Post Rack, on page 80](#)
- [Install the FIPS Opacity Shield in a Four-Post Rack, on page 83](#)

Install, Remove, and Replace the Network Module

You can remove and replace the network module in the Firepower 2130 and 2140 (the Firepower 2110 and 2120 do not support network modules). Although the hardware supports removing and replacing the network module while the system is running, the software does not currently support hot swapping. You must power down the chassis to remove and replace network modules. See [Network Modules, on page 19](#) for more information.

This procedure describes how to install a network module into an empty slot that has never contained a network module, and how to remove an installed network module and replace it with another network module.

Safety Warnings

Take note of the following component replacement safety warnings:



Warning **Statement 1028**—More Than One Power Supply

This unit might have more than one power supply connection. To reduce risk of electric shock, remove all connections to de-energize the unit.

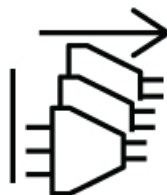

**Warning Statement 1073**—No User-Serviceable Parts

There are no serviceable parts inside. To avoid risk of electric shock, do not open.

**Warning Statement 1089**—Instructed and Skilled Person Definitions

An instructed person is someone who has been instructed and trained by a skilled person and takes the necessary precautions when working with equipment.

A skilled person or qualified personnel is someone who has training or experience in the equipment technology and understands potential hazards when working with equipment.

There are no serviceable parts inside. To avoid risk of electric shock, do not open.

**Warning Statement 1090**—Installation by Skilled Person

Only a skilled person should be allowed to install, replace, or service this equipment. See statement 1089 for the definition of a skilled person.

There are no serviceable parts inside. To avoid risk of electric shock, do not open.

**Warning Statement 1091**—Installation by an Instructed Person

Only an instructed person or skilled person should be allowed to install, replace, or service this equipment. See statement 1089 for the definition of an instructed or skilled person.

There are no serviceable parts inside. To avoid risk of electric shock, do not open.

Step 1 To install a new network module for the first time into an empty slot, do the following:

- a) Power down the chassis by moving the power switch to the OFF position.
See [Rear Panel](#) for more information about the power switch.
- b) Follow Steps 4 through 7 to install the new network module.
- c) Power on the chassis by moving the power switch to the ON position.

Step 2 To remove and replace an existing network module, do the following:

- a) Save your configuration.
- b) Power down the chassis by moving the power switch to the OFF position.
See [Rear Panel](#) for more information about the power switch.
- c) Continue with Step 3.

Step 3 To remove a network module, loosen the captive screw on the lower left side of the network module and pull out the handle that is connected to the screw. This mechanically ejects the network module from the slot.

Figure 47: Remove the Network Module

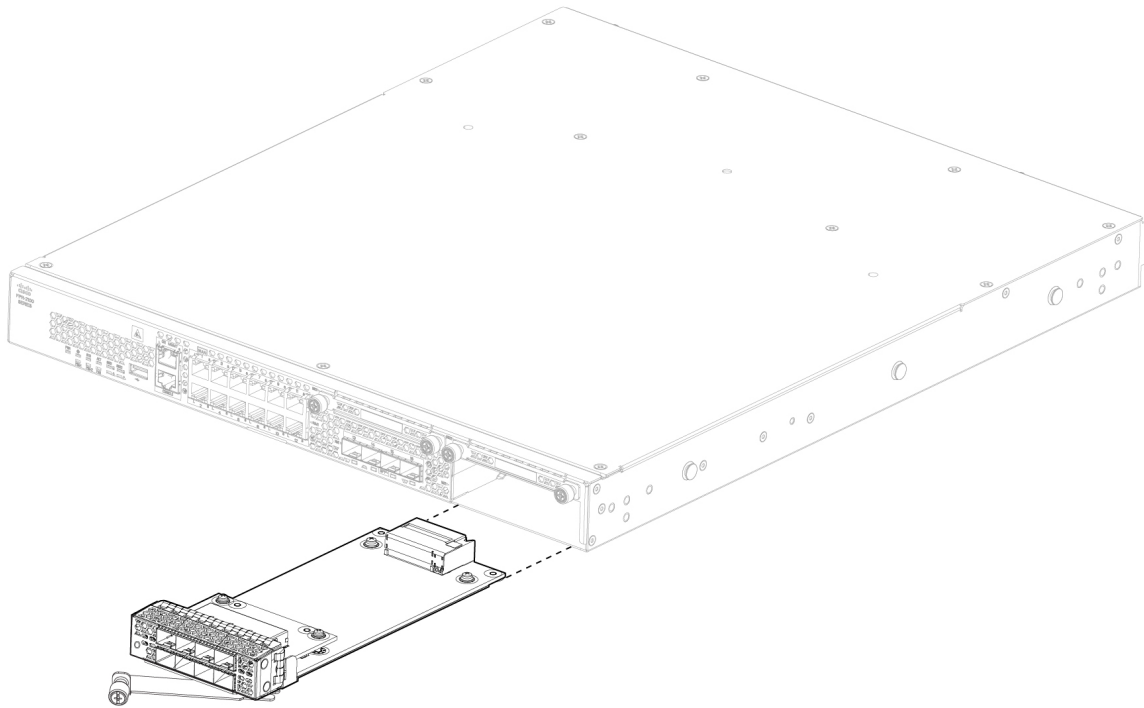

If the slot is to remain empty, install a blank faceplate to ensure proper airflow and to keep dust out of the chassis; otherwise, install another network module.

- Step 4** To replace a network module, hold the network module in front of the network module slot on the right of the chassis and pull the network module handle out.
- Step 5** Slide the network module into the slot and push it firmly into place until the handle is flush with the front of the network module.
- Step 6** Tighten the captive screw on the lower left side of the network module.
- Step 7** Power on the chassis so that the new network module is recognized.

Remove and Replace the SSD

Although the hardware supports removing and replacing SSDs while the system is running, the software does not currently support hot swapping. You must power down the chassis to remove and replace SSDs.



Note The 100-GB SSD is restricted to the Firepower 2110 and 2120. The 200-GB SSD is restricted to the Firepower 2130 and 2140. Do not mix them.



Note We may ship larger capacity SSDs depending on component supply availability. The larger capacity SSDs are formatted to 100-GB for the Firepower 2110 and 2120 and formatted to 200-GB for the Firepower 2130 and 2140.

You can install a Malware Storage Pack (MSP) in slot 2. The MSP stores threat detection data for use in future analysis. It supports the Advanced Malware Protection (AMP) software feature. It is used as both storage and as the Malware application repository. RAID is not supported.



Caution Do not switch the two SSDs. You *must* install the MSP in slot 2. If you remove it and install it in slot 1, all stored capture data are lost.

Safety Warnings

Take note of the following component replacement safety warnings:



Warning Statement 1028—More Than One Power Supply

This unit might have more than one power supply connection. To reduce risk of electric shock, remove all connections to de-energize the unit.



Warning Statement 1073—No User-Serviceable Parts

There are no serviceable parts inside. To avoid risk of electric shock, do not open.



Warning Statement 1089—Instructed and Skilled Person Definitions

An instructed person is someone who has been instructed and trained by a skilled person and takes the necessary precautions when working with equipment.

A skilled person or qualified personnel is someone who has training or experience in the equipment technology and understands potential hazards when working with equipment.

There are no serviceable parts inside. To avoid risk of electric shock, do not open.



Warning Statement 1090—Installation by Skilled Person

Only a skilled person should be allowed to install, replace, or service this equipment. See statement 1089 for the definition of a skilled person.

There are no serviceable parts inside. To avoid risk of electric shock, do not open.



Warning Statement 1091—Installation by an Instructed Person

Only an instructed person or skilled person should be allowed to install, replace, or service this equipment. See statement 1089 for the definition of an instructed or skilled person.

There are no serviceable parts inside. To avoid risk of electric shock, do not open.

- Step 1** Save your configuration.
- Step 2** Power down the chassis by moving the power switch to the OFF position. See [Rear Panel, on page 17](#) for more information on the power switch.
- Step 3** To remove the SSD in slot 1, face the front of the chassis, loosen the two captive screws on the SSD, and gently pull it out of the chassis. See [Front Panel, on page 10](#) for the location of the SSD slots for each model. The figure below shows the 2130 and 2140 front panel.

Figure 48: Remove the SSD

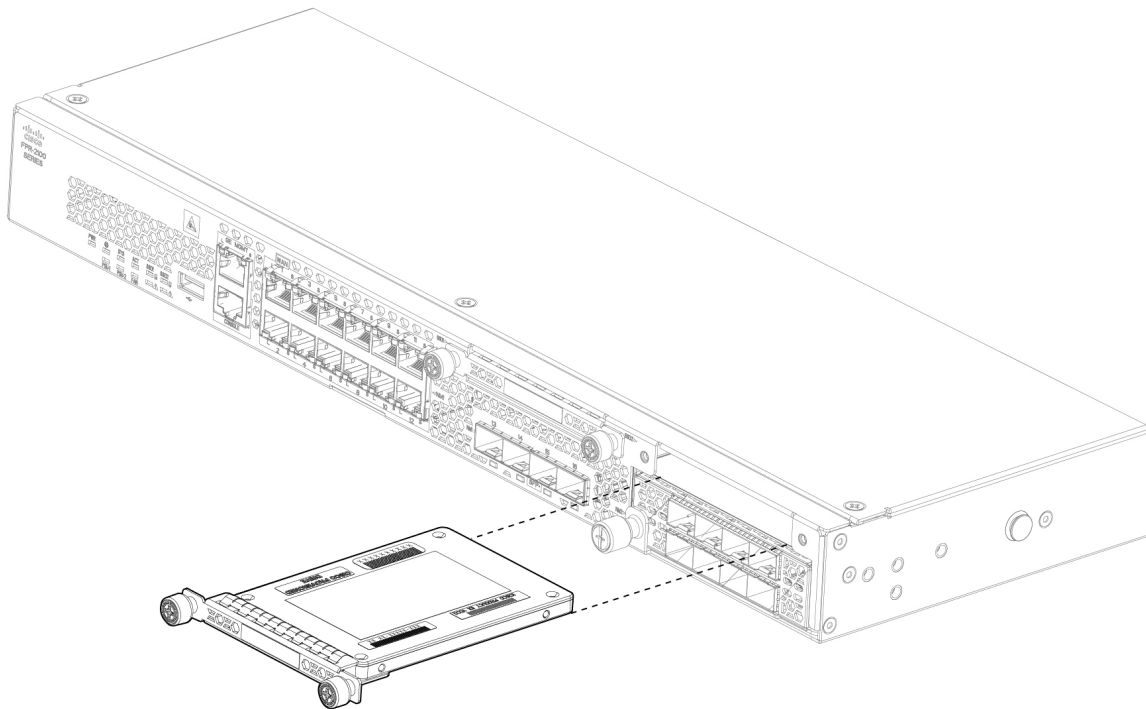

- Step 4** To replace the SSD in slot 1, make sure the power switch is still in the OFF position, and then hold the SSD in front of slot 1 and push it in gently until it is seated.

- Step 5** To install the MSP SSD, make sure the power switch is still in the OFF position, and then remove the blank faceplate in Slot 2 by loosening the captive screws on either side of the faceplate.
- Step 6** Hold the MSP SSD in front of slot 2 and push it in gently until it is seated.
- Caution** Do not switch the two SSDs. The MSP *must* be installed in slot 2. If you remove it and install it in slot 1, all stored file capture data are lost.
- Step 7** Tighten the captive screws on either side of the SSD.
- Step 8** Check the SSD LED to make sure the SSD is operative. See [Front Panel LEDs, on page 12](#) for a description of the SSD LEDs.

Remove and Replace the Power Supply Module

You can remove and replace the power supply module in the Firepower 2130 and 2140 (the Firepower 2110 and 2120 have one fixed AC power supply module). Power supply modules are hot-swappable. You can remove and replace them while the system is running.

Safety Warnings

Take note of the following power and component removal safety warnings:



Warning **Statement 1003**—DC Power Disconnection

To reduce risk of electric shock or personal injury, disconnect DC power before removing or replacing components or performing upgrades.



Warning **Statement 1005**—Circuit Breaker

This product relies on the building's installation for short-circuit (overcurrent) protection. To reduce risk of electric shock or fire, ensure that the protective device is rated not greater than:

AC: 20A

DC: 40A



Warning **Statement 1017**—Restricted Area

This unit is intended for installation in restricted access areas. Only skilled, instructed, or qualified personnel can access a restricted access area.



Warning **Statement 1022**—Disconnect Device

To reduce the risk of electric shock and fire, a readily accessible disconnect device must be incorporated in the fixed wiring.



Warning **Statement 1028**—More Than One Power Supply

This unit might have more than one power supply connection. To reduce risk of electric shock, remove all connections to de-energize the unit.



Warning **Statement 1029**—Blank Faceplates and Cover Panels

Blank faceplates and cover panels serve three important functions: they reduce the risk of electric shock and fire, they contain electromagnetic interference (EMI) that might disrupt other equipment, and they direct the flow of cooling air through the chassis. Do not operate the system unless all cards, faceplates, front covers, and rear covers are in place.



Warning **Statement 1073**—No User-Serviceable Parts

There are no serviceable parts inside. To avoid risk of electric shock, do not open.



Warning **Statement 1046**—Installing or Replacing the Unit

To reduce risk of electric shock, when installing or replacing the unit, the ground connection must always be made first and disconnected last.

If your unit has modules, secure them with the provided screws.



Warning **Statement 1089**—Instructed and Skilled Person Definitions

An instructed person is someone who has been instructed and trained by a skilled person and takes the necessary precautions when working with equipment.

A skilled person or qualified personnel is someone who has training or experience in the equipment technology and understands potential hazards when working with equipment.

There are no serviceable parts inside. To avoid risk of electric shock, do not open.



Warning Statement 1090—Installation by Skilled Person

Only a skilled person should be allowed to install, replace, or service this equipment. See statement 1089 for the definition of a skilled person.

There are no serviceable parts inside. To avoid risk of electric shock, do not open.



Warning Statement 1091—Installation by an Instructed Person

Only an instructed person or skilled person should be allowed to install, replace, or service this equipment. See statement 1089 for the definition of an instructed or skilled person.

There are no serviceable parts inside. To avoid risk of electric shock, do not open.

- Step 1** Unplug the power supply cable before removing the power supply module. You cannot disengage the power supply module latch without first removing the cable.
- Step 2** To remove a power supply module, face the back of the chassis and grasp the handle.
- Step 3** Press the latch found on the right of the power supply to disengage the power supply.
- Step 4** Place your other hand under the power supply module to support it while you slide it out of the chassis.

Figure 49: Remove the Power Supply Module

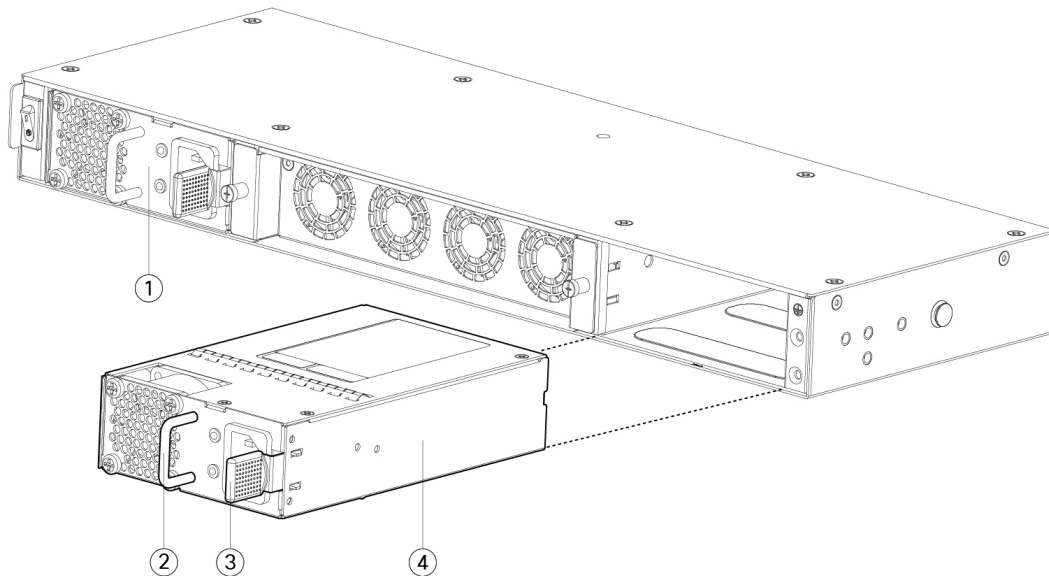

1	Power supply module 1	2	Power supply module handle
3	Power supply module latch		Power supply module 2

If the slot is to remain empty, install a blank faceplate to ensure proper airflow and to keep dust out of the chassis; otherwise, install another power supply module.

- Step 5** To replace a power supply module, hold the power supply module with both hands and slide it into the power supply module bay.
- Step 6** Push in the power supply module gently until you hear the latch engage and it is seated.
- Step 7** Plug in the power supply cable.
- Step 8** Check the LED on the power supply to make sure the power supply is operative. See [Power Supply Modules](#), on page 27.

Connect the DC Power Supply Module

For the Firepower 2130 and 2140 (the Firepower 2110 and 2120 do not support DC power), the input connector and plug must be UL-recognized under UL 486 for field wiring. The connection polarity is from left to right: negative (–), positive (+), and ground.

Use the handle on the power supply for installation and removal. You must support the module with one hand because of its length.

Figure 50: Firepower 2100 DC Power Supply Module

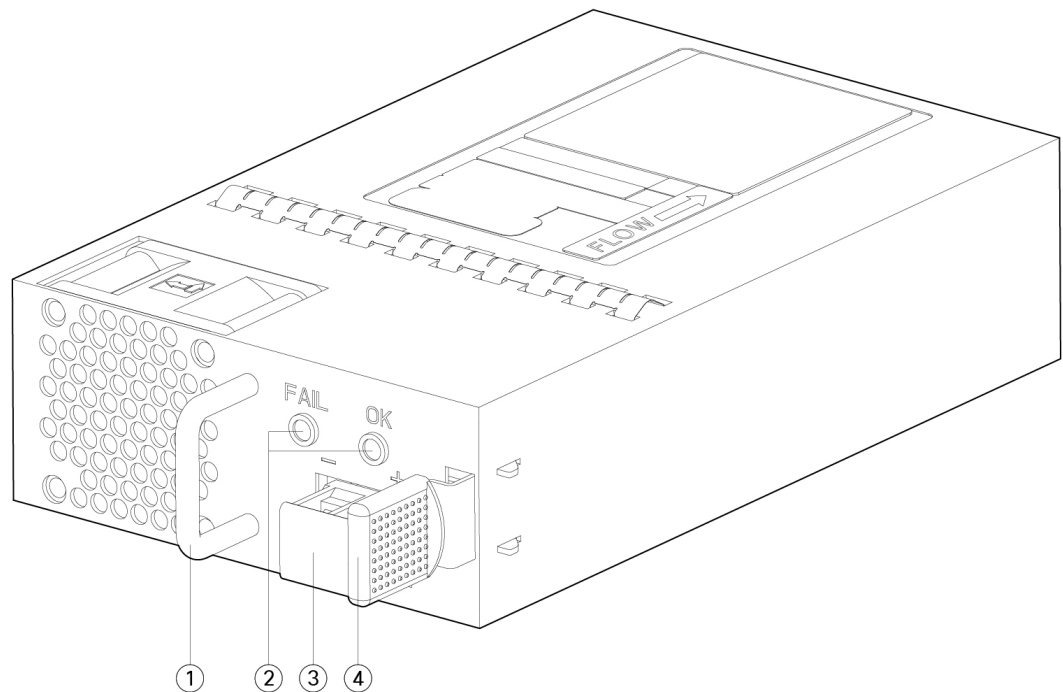

1	Handle	2	FAIL and OK LEDs
3	DC power connector	4	Ejector latch

Safety Warnings

Take note of the following warnings:



Warning Statement 1003—DC Power Disconnection

To reduce risk of electric shock or personal injury, disconnect DC power before removing or replacing components or performing upgrades.



Warning Statement 1005—Circuit Breaker

This product relies on the building's installation for short-circuit (overcurrent) protection. To reduce risk of electric shock or fire, ensure that the protective device is rated not greater than:

AC: 20A

DC: 40A



Warning Statement 1017—Restricted Area

This unit is intended for installation in restricted access areas. Only skilled, instructed, or qualified personnel can access a restricted access area.



Warning Statement 1022—Disconnect Device

To reduce the risk of electric shock and fire, a readily accessible disconnect device must be incorporated in the fixed wiring.



Warning Statement 1028—More Than One Power Supply

This unit might have more than one power supply connection. To reduce risk of electric shock, remove all connections to de-energize the unit.





Warning Statement 1029—Blank Faceplates and Cover Panels

Blank faceplates and cover panels serve three important functions: they reduce the risk of electric shock and fire, they contain electromagnetic interference (EMI) that might disrupt other equipment, and they direct the flow of cooling air through the chassis. Do not operate the system unless all cards, faceplates, front covers, and rear covers are in place.



Warning Statement 1073—No User-Serviceable Parts

There are no serviceable parts inside. To avoid risk of electric shock, do not open.



Warning Statement 1046—Installing or Replacing the Unit

To reduce risk of electric shock, when installing or replacing the unit, the ground connection must always be made first and disconnected last.

If your unit has modules, secure them with the provided screws.



Warning Statement 1089—Instructed and Skilled Person Definitions

An instructed person is someone who has been instructed and trained by a skilled person and takes the necessary precautions when working with equipment.

A skilled person or qualified personnel is someone who has training or experience in the equipment technology and understands potential hazards when working with equipment.

There are no serviceable parts inside. To avoid risk of electric shock, do not open.



Warning Statement 1090—Installation by Skilled Person

Only a skilled person should be allowed to install, replace, or service this equipment. See statement 1089 for the definition of a skilled person.

There are no serviceable parts inside. To avoid risk of electric shock, do not open.



Warning Statement 1091—Installation by an Instructed Person

Only an instructed person or skilled person should be allowed to install, replace, or service this equipment. See statement 1089 for the definition of an instructed or skilled person.

There are no serviceable parts inside. To avoid risk of electric shock, do not open.

Before you begin

- The color coding of the DC input power supply leads depends on the color coding of the DC power source at your site. Make sure that the lead color coding you choose for the DC input power supply matches the lead color coding used at the DC power source and verify that the power source is connected to the negative (–) terminal and to the positive (+) terminal on the power supply.
- Make sure that the chassis ground is connected on the chassis before you begin installing the DC power supply. See [Ground the Chassis, on page 60](#) for the procedure.

-
- Step 1** Verify that the power is off to the DC circuit on the power supply module that you are installing.
- Step 2** While supporting the power supply module with one hand, insert the power supply module into the power supply bay and gently push it in. See the figure above for the location of the handle.
- Step 3** Use a wire-stripping tool to strip each of the 2 wires coming from the DC input power source. Strip the wires to approximately 0.39 inch (10 mm) + 0.02 inch (0.5 mm). We recommend you use 14 AWG insulated wire.
- Note** Do not strip more than the recommended length of wire because doing so could leave the wire exposed from the terminal block.

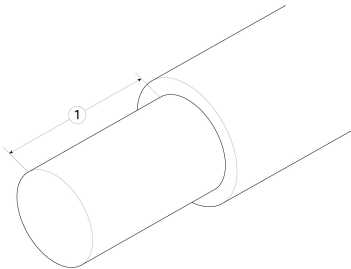
Figure 51: Stripped DC Input Source Wire

1	Strip the wires to approximately 0.39 inch (10 mm) + 0.02 inch (0.5 mm)	—
----------	---	---

- Step 4** Insert the exposed wire into the terminal block. Make sure that you cannot see any wire lead outside the plastic cover. Only wires with insulation should extend from the terminal block.
- Step 5** Use a screwdriver to tighten the terminal block captive screws.
- Caution** Do not over torque the terminal block captive screws. Make sure that the connection is snug, but the wire is not crushed. Verify by tugging lightly on each wire to make sure that they do not move.

Figure 52: Tighten the Terminal Block Captive Screws

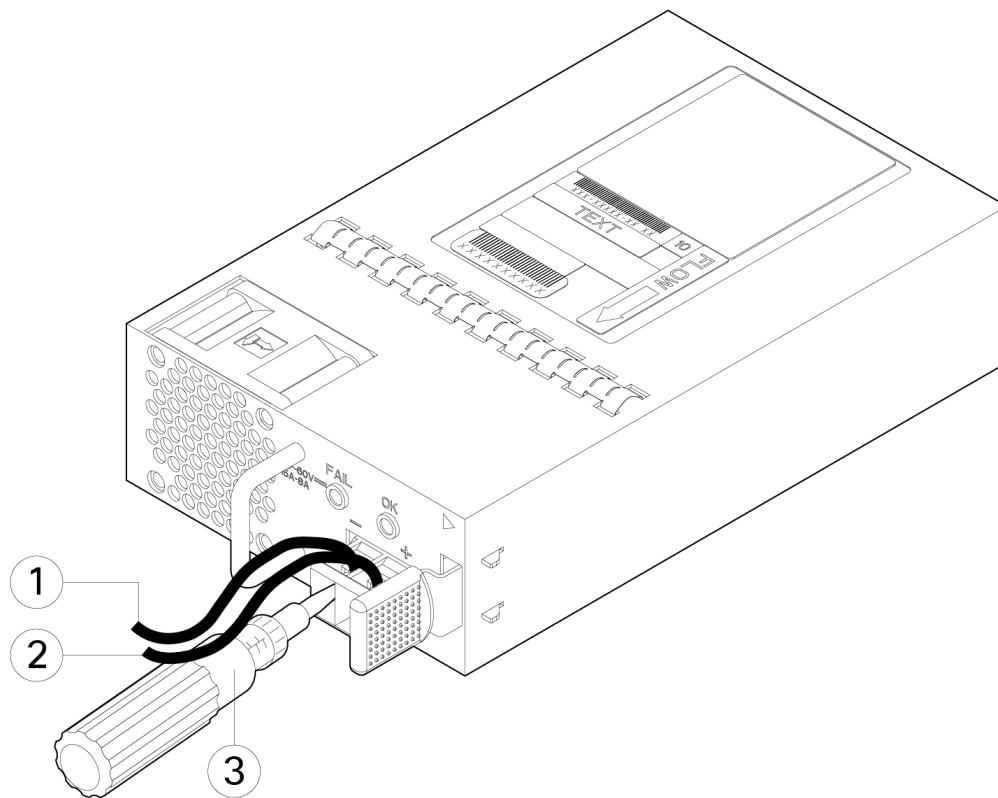

1	Negative (-) lead wire	2	Positive (+) lead wire
---	------------------------	---	------------------------

- Step 6** Repeat these steps for the remaining DC input power source wire as applicable.
- Step 7** Use a tie wrap to secure the wires to the rack, so that the wires are not pulled from the terminal block.
- Step 8** Set the DC disconnect switch in the circuit to ON. In a system with multiple power supplies, connect each power supply to a separate DC power source. In the event of a power source failure, if the second source is still available, it can maintain system operation.
- Step 9** Verify power supply operation by checking the power supply LED on the front of the chassis. See [Front Panel LEDs](#), on page 12 for the LED values.

Secure the Power Cord on the Power Supply Module

To secure the power supply module against accidental removal and thus prevent disrupting system performance, use the tie wrap and clamp provided in the accessories kit that ships with your Firepower 2100.

Safety Warnings

Take note of the following component replacement safety warnings:



Warning Statement 1028—More Than One Power Supply

This unit might have more than one power supply connection. To reduce risk of electric shock, remove all connections to de-energize the unit.

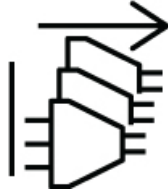

Warning Statement 1073—No User-Serviceable Parts

There are no serviceable parts inside. To avoid risk of electric shock, do not open.



Warning Statement 1089—Instructed and Skilled Person Definitions

An instructed person is someone who has been instructed and trained by a skilled person and takes the necessary precautions when working with equipment.

A skilled person or qualified personnel is someone who has training or experience in the equipment technology and understands potential hazards when working with equipment.

There are no serviceable parts inside. To avoid risk of electric shock, do not open.



Warning Statement 1090—Installation by Skilled Person

Only a skilled person should be allowed to install, replace, or service this equipment. See statement 1089 for the definition of a skilled person.

There are no serviceable parts inside. To avoid risk of electric shock, do not open.



Warning Statement 1091—Installation by an Instructed Person

Only an instructed person or skilled person should be allowed to install, replace, or service this equipment. See statement 1089 for the definition of an instructed or skilled person.

There are no serviceable parts inside. To avoid risk of electric shock, do not open.

Step 1 Attach the clamp to the tie wrap by holding the clamp with the loop side on the bottom and sliding the tie wrap through the box-shaped channel above the clamp (see the following figure).

One side of the tie wrap has evenly spaced ridges and the other is smooth. Be sure the ridged side is face up and that you slide it through the open side of the channel. You will hear a click as the tie slides through—it moves in one direction

only. To remove the tie wrap from the clamp, push the lever on the closed side of the box-shaped channel and slide out the tie wrap.

Figure 53: Tie Wrap Through the Box Channel of the Clamp

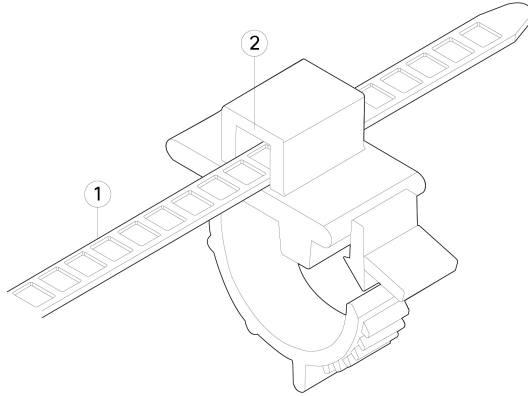

1	Box channel	2	Tie wrap
----------	-------------	----------	----------

Step 2

Attach the clamp to the power supply module:

- a) Locate the hexagonal ventilation hole on the power supply module at the center of the plug just below the power connector body (see the following figures).
- b) Plug the snapping portion of the tie wrap into the hexagonal hole.
- c) With the clamp side facing up, push the tie wrap in until it is fully engaged.

Caution Make sure you have the correct location because you cannot remove the tie wrap from the power supply module once you have installed it without damaging the tie wrap.

Figure 54: Connect the Tie Wrap

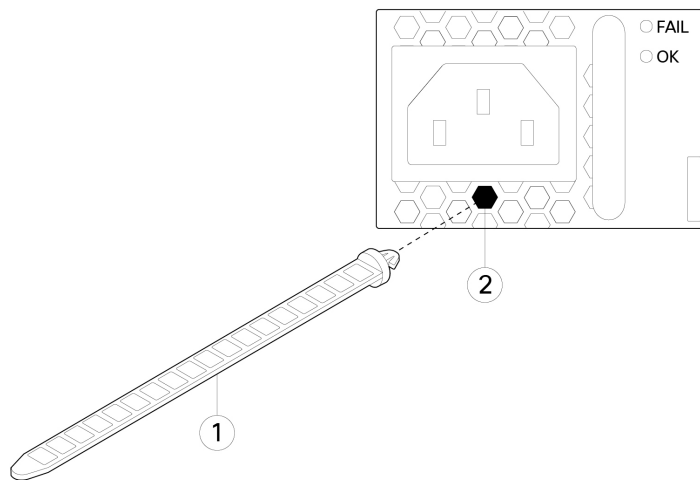

1	Tie wrap	2	Hexagonal hole
---	----------	---	----------------

Step 3 Secure the clamp:

- Plug in the power supply power cord and wrap the clamp around the over mold portion of the power cord.
- Squeeze the clamp tabs together so that the annular teeth engage with the mate on the clamp.
- Make sure the clamp fits snugly into the over mold.
- Adjust the clamp position on the tie wrap so that the clamp is tight against the front of the over mold and the power cord cannot be removed by lightly pulling on it.

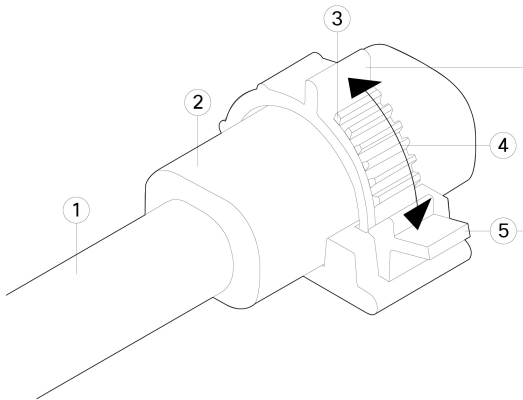
Figure 55: Clamp on Over Mold of Power Cord

1	Power cord	2	Power cord over mold
3	Tie clamp annular teeth	4	Direction to squeeze the clamp tabs
5	Clamp release tabs		—

- Step 4** If you need to remove the power cord, push the release tab on the clamp to force the annular clamp teeth to disengage and the clamp opens up. You can then remove the clamp from the power cord.

Remove and Replace the Fan Tray

You can remove and replace the fan tray while the Firepower 2130 and 2140 are running (the Firepower 2110 and 2120 have two fixed fans). The air flow moves from front to back. All fan modules are integrated in a single fan tray.



Caution Removing the fan tray exposes the appliance to no airflow. Replace the fan tray within 30 seconds after removal to avoid overheating the appliance. If you wait longer than 30 seconds, the appliance may power off automatically to prevent damage to components. The appliance does not power up and boot properly if the fan tray is missing.

Safety Warnings

Take note of the following component replacement safety warnings:



Warning Statement 1028—More Than One Power Supply

This unit might have more than one power supply connection. To reduce risk of electric shock, remove all connections to de-energize the unit.

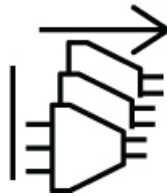

Warning Statement 1073—No User-Serviceable Parts

There are no serviceable parts inside. To avoid risk of electric shock, do not open.



Warning Statement 1089—Instructed and Skilled Person Definitions

An instructed person is someone who has been instructed and trained by a skilled person and takes the necessary precautions when working with equipment.

A skilled person or qualified personnel is someone who has training or experience in the equipment technology and understands potential hazards when working with equipment.

There are no serviceable parts inside. To avoid risk of electric shock, do not open.



Warning Statement 1090—Installation by Skilled Person

Only a skilled person should be allowed to install, replace, or service this equipment. See statement 1089 for the definition of a skilled person.

There are no serviceable parts inside. To avoid risk of electric shock, do not open.



Warning Statement 1091—Installation by an Instructed Person

Only an instructed person or skilled person should be allowed to install, replace, or service this equipment. See statement 1089 for the definition of an instructed or skilled person.

There are no serviceable parts inside. To avoid risk of electric shock, do not open.

- Step 1** Have the fan tray ready for immediate insertion and near the appliance so that you can reinstall the fan tray within 30 seconds.
- Step 2** To remove a fan tray, face the rear of the chassis, and loosen the two captive screws on the fan tray.
- Step 3** Pull the fan tray out of the chassis.

Figure 56: Remove the Fan Tray

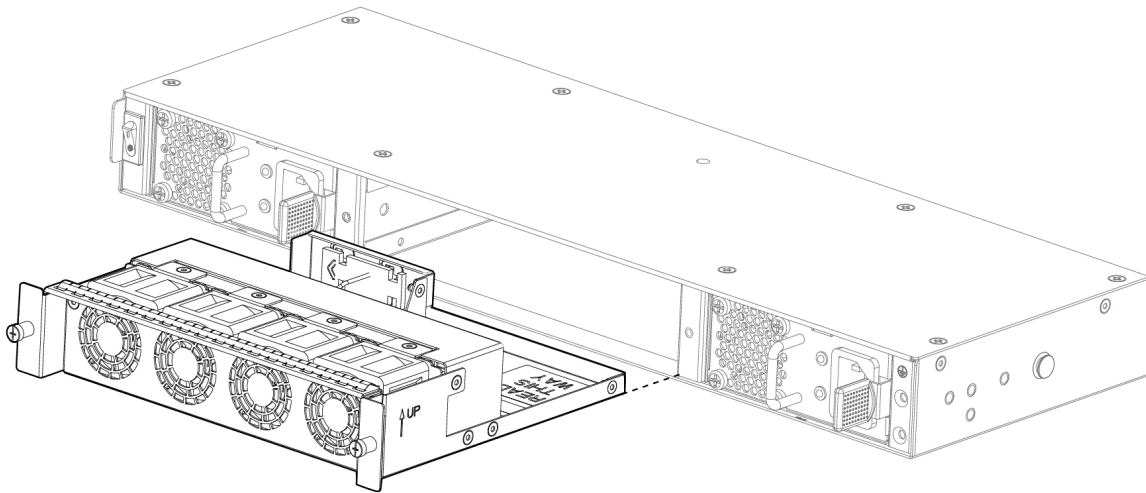

- Step 4** To replace a fan tray, hold the fan tray in front of the fan slot.
- Step 5** Push the fan tray into the chassis until it is properly seated, and tighten the captive screws. If the system is powered on, listen for the fans. You should immediately hear the fans operating. If you do not hear the fans, make sure the fan tray is inserted completely into the chassis and the faceplate is flush with the outside surface of the chassis.
- Step 6** Verify that the fan is operational by checking the fan tray LED. See [Front Panel LEDs, on page 12](#) for a description of the fan LEDs.

Install the FIPS Opacity Shield in a Two-Post Rack



Note Because the FIPS opacity shield covers the serial number on the chassis, the Crypto Officer (CO) should copy the serial number and store it in a secure place. The serial number is needed when you call Cisco TAC.



Caution This procedure should be performed only by the CO.

You need the following to install the FIPS opacity shield:

- #1 Phillips screwdriver
- The following items from the FIPS kit:

- One FIPS opacity shield
- Four 8-32 x 0.375-inch Phillips screws used to attach the FIPS opacity shield to the cable management brackets
- Seven Tamper Evidence Labels (TEL)



Note The TELs are made of a special thin gauge vinyl with self-adhesive backing. Once the CO attaches them on the chassis, any attempt to open the chassis damages the TELs or the chassis cover. Because the TELs have nonrepeated serial numbers, the CO can inspect them for damage and compare them against the applied serial numbers to verify whether the chassis has been tampered with. TELs with curled corners, rips, and slices indicate tampering. The word “FIPS” or “OPEN” may appear if the label has been peeled back.

-
- Step 1** Copy the serial number and store in a secure place. To find the serial number, see [Serial Number Location](#).
- Step 2** Perform the steps described in [Rack-Mount the Chassis Using Brackets](#) including installing the cable management bracket (Step 2).
- Step 3** Connect the cables to the ports. Make sure that the cables have enough slack to route them through the cable mounting brackets.
- Note** If you are installing the FIPS opacity shield after the initial product installation, the cables are connected. If the attached cables do not have enough slack to route them through the cable mounting brackets (as shown in the figure below), you will have to turn the power off on the appliance, remove the cables, route the cables through the cable mounting brackets, reattach the cables, and continue with Step 5 below.
- Note** When you toggle the power switch from ON to OFF, it takes several seconds for the system to power down. Do not remove the power cable until the power LED is off. After removing power from the chassis either by moving the power switch to OFF or unplugging the power cord, wait at least 10 seconds before turning power back ON.
- Step 4** Route the cables through the openings in the cable management brackets as shown in the figure below.
- Step 5** Attach the FIPS opacity shield to the cable management brackets using the four 8-32 x 0.375-inch Phillips screws provided in the FIPS kit as shown in the figure below.

Figure 57: Route the Cables and Attach the Screws

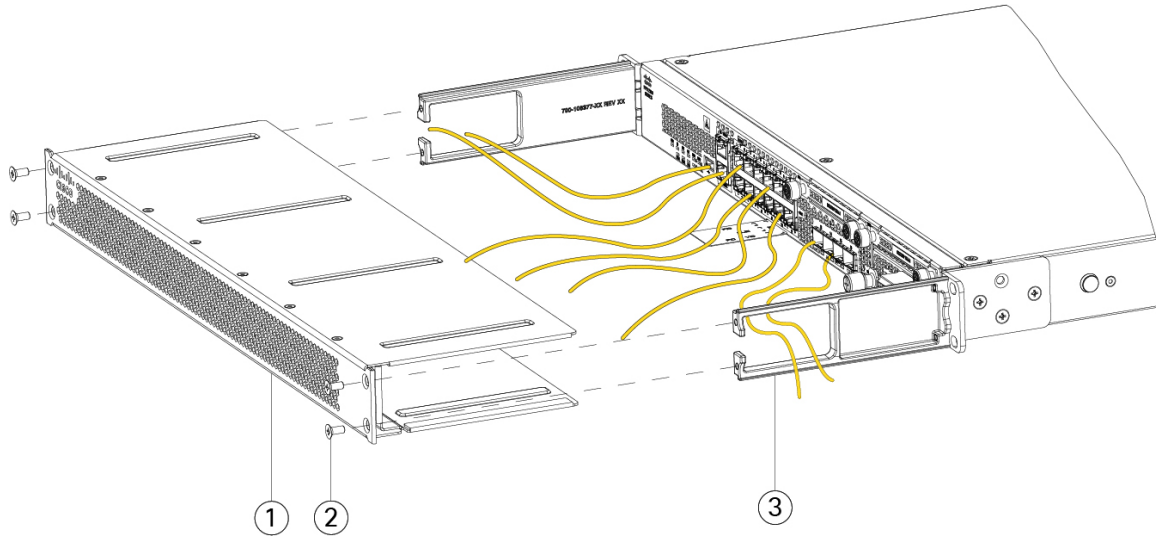

1	FIPS opacity shield	2	8-32 x 0.375-inch Phillips screws (two per side)
3	Cable management bracket		—

Step 6 Before you attach the TELs, clean the chassis and FIPS cover of any grease, dirt, or oil with alcohol-based cleaning pads.

Step 7 Attach the seven TELs. See the figure below for the correct placement. Allow the TELs to cure for a minimum of 12 hours.

Caution Any deviation in the placement of the TELs means the chassis is not in FIPS mode.

Figure 58: TELs Placement on the Chassis

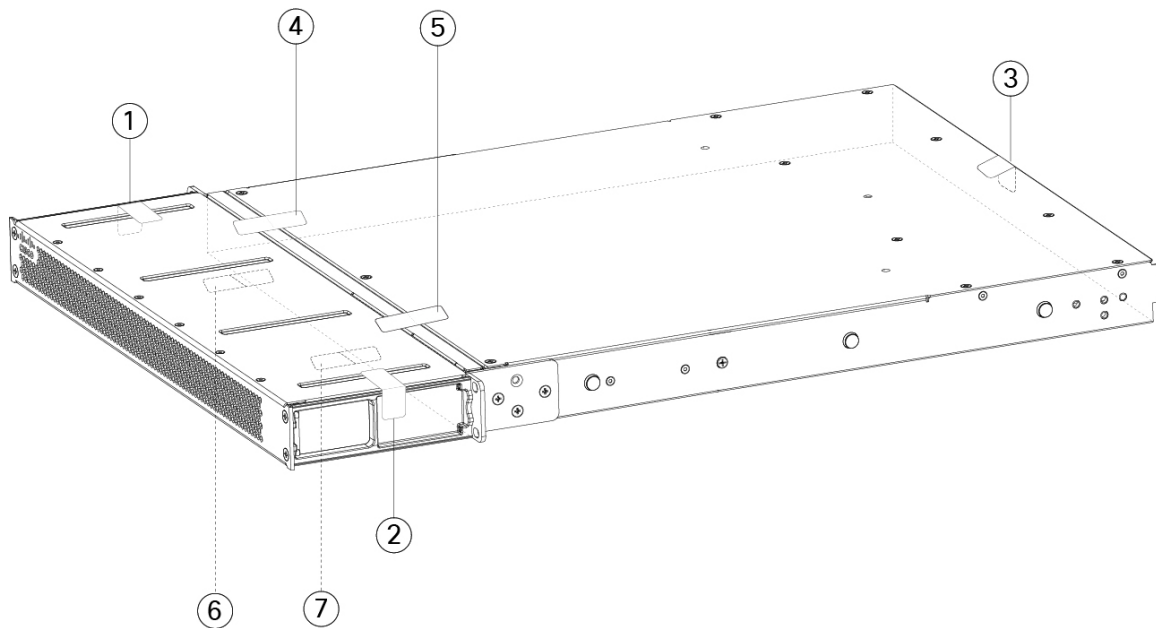

1	TEL 1 on the left side and top of chassis	2	TEL 2 on the right side and top of chassis
3	TEL 3 on the top and back of chassis	4	TEL 4 across the FIPS shield and the chassis (towards the left of the chassis)
5	TEL 5 across the FIPS shield and the chassis (towards the right of the chassis)	6	TEL 6 on the bottom of the chassis towards the left side of the chassis
7	TEL 7 on the bottom of the chassis towards the right side of the chassis		—

Step 8 Attach the power cable to the chassis and connect it to an electrical outlet.

Step 9 Press the power switch on the rear panel.

Step 10 Check the power LED on the front panel. See [Front Panel LEDs](#) for a description of the power LED. Solid green indicates that the chassis is powered on.

Step 11 Place the chassis in FIPS mode.

See the following procedures for how to place the chassis in FIPS mode:

- [ASA in Platform Mode](#)
- [ASA in Appliance mode](#)
- [FTD managed by FMC](#)

What to do next

See the [Cisco Firepower 2100 Getting Started Guide](#) for your operating system for further configuration information.

Install the FIPS Opacity Shield in a Four-Post Rack



Caution This procedure should be performed only by the Crypto Officer (CO).



Note Because the FIPS opacity shield covers the serial number on the chassis, the CO should copy the serial number and store it in a secure place. The serial number is needed when you call Cisco TAC.

You need the following to install the FIPS opacity shield:

- #1 Phillips screwdriver
- The following items from the FIPS kit:
 - One FIPS opacity shield

- Four 8-32 x 0.375-inch-Phillips screws used to attach the FIPS opacity shield to the cable management brackets
- Seven Tamper Evidence Labels (TEL)



Note The TELs are made of a special thin gauge vinyl with self-adhesive backing. Once the CO attaches them on the chassis, any attempt to open the chassis damages the TELs or the chassis cover. Because the TELs have nonrepeated serial numbers, the CO can inspect them for damage and compare them against the applied serial numbers to verify whether the chassis has been tampered with. TELs with curled corners, rips, and slices indicate tampering. The word “FIPS” or “OPEN” may appear if the label has been peeled back.

Step 1 Copy the serial number and store it in a secure place. To find the serial number, see [Serial Number Location](#).

Step 2 Perform the steps described in [Rack-Mount the Chassis Using Slide Rails](#).

Step 3 Connect the cables to the ports. Make sure the cables have enough slack to route them through the cable mounting brackets.

Note If you are installing the FIPS opacity shield after the initial product installation, the cables are connected. If the attached cables do not have enough slack to route them through the cable mounting brackets (as shown below), you will have to turn the power off on the appliance, remove the cables, route the cables through the cable mounting brackets, reattach the cables, and continue with Step 5 below.

Note When you toggle the power switch from ON to OFF, it takes several seconds for the system to power down. Do not remove the power cable until the power LED is off. After removing power from the chassis either by moving the power switch to OFF or unplugging the power cord, wait at least 10 seconds before turning power back ON.

Step 4 Route the cables through the openings in the cable management brackets (see figure below).

Step 5 Attach the FIPS opacity shield to the cable management brackets using the four 8-32 x 0.375 inch Phillips screws provided in the FIPS kit.

Figure 59: Route the Cables and Attach the Screws

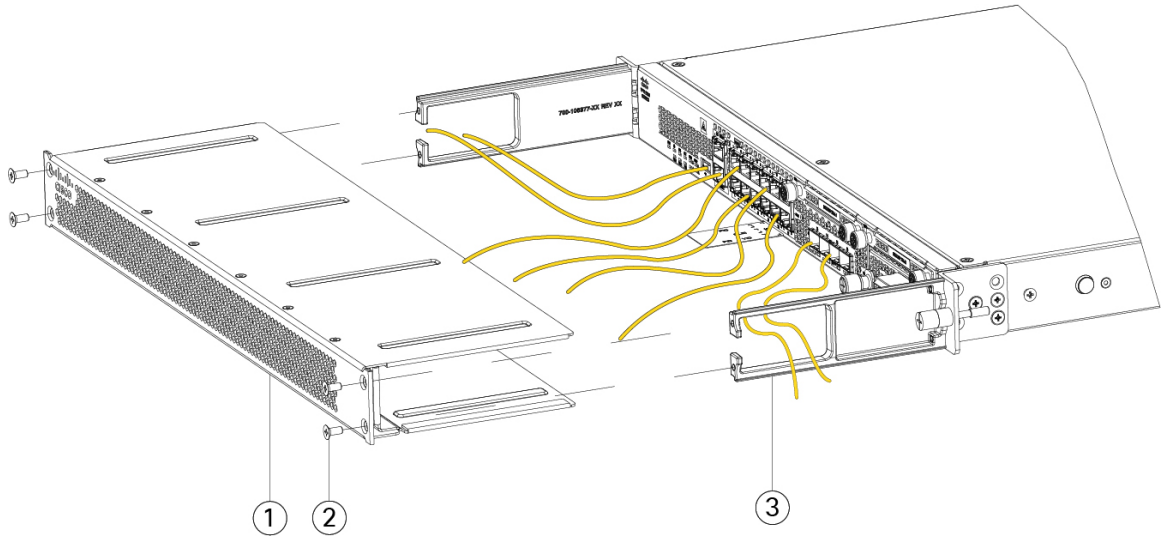

1	FIPS opacity shield	2	8-32 x 0.375 inch-Phillips screws (two per side)
3	Cable management bracket		

Step 6

Before you attach the TELs, clean the chassis of any grease, dirt, or oil with alcohol-based cleaning pads.

Step 7

Attach the seven TELs. See the figure below for the correct placement. Allow the TELs to cure for a minimum of 12 hours.

Caution Any deviation in the placement of the TELs means the chassis is not in FIPS mode.

Figure 60: TELs Placement on the Chassis

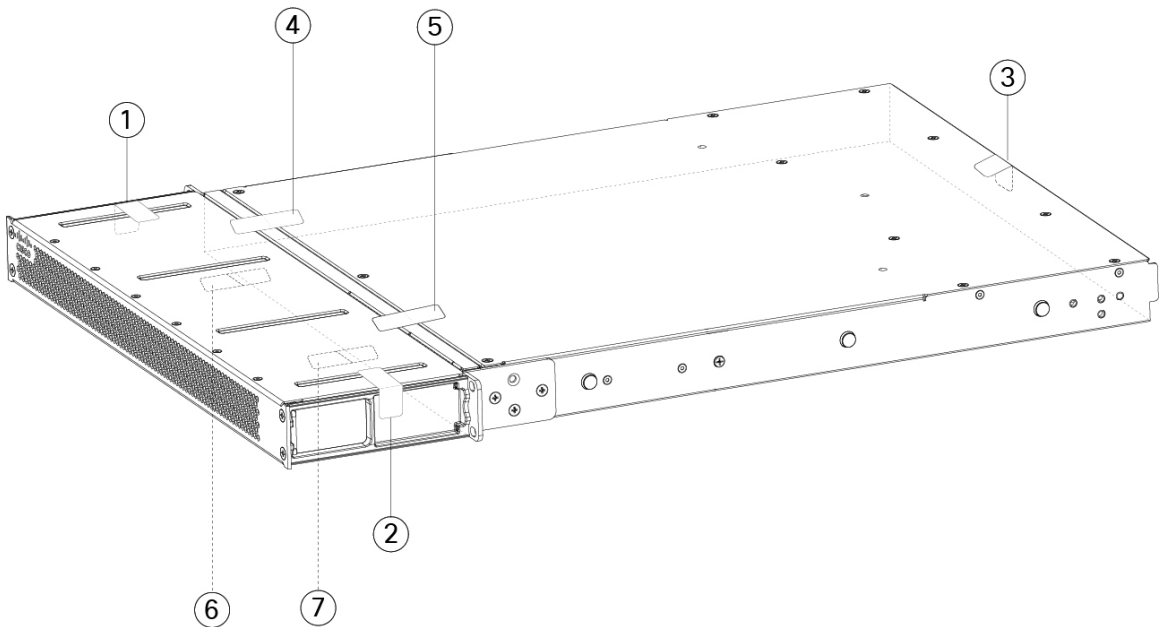

1	TEL 1 on the left side and top of chassis	2	TEL 2 on the right side and top of chassis
3	TEL 3 on the top and back of chassis	4	TEL 4 across the FIPS shield and the chassis (towards the left of the chassis)
5	TEL 5 across the FIPS shield and the chassis (towards the right of the chassis)	6	TEL 6 on the bottom of the chassis towards the left side of the chassis
7	TEL 7 on the bottom of the chassis towards the right side of the chassis		—

Step 8 Attach the power cable to the chassis and connect it to an electrical outlet.

Step 9 Press the power switch on the rear panel.

Step 10 Check the power LED on the front panel. See [Front Panel LEDs](#) for a description of the power LED. Solid green indicates that the chassis is powered on.

Step 11 Place the chassis in FIPS mode.

See the following procedures for how to place the chassis in FIPS mode:

- [ASA in Platform Mode](#)
- [ASA in Appliance mode](#)
- [FTD managed by FMC](#)

What to do next

See the [Cisco Firepower 2100 Getting Started Guide](#) for your operating system for further configuration information.