



High Availability Installation Guide for Cisco Security Manager 4.9

August 5, 2015

Cisco Systems, Inc.

www.cisco.com

Cisco has more than 200 offices worldwide. Addresses, phone numbers, and fax numbers are listed on the Cisco website at www.cisco.com/go/offices.

THE SPECIFICATIONS AND INFORMATION REGARDING THE PRODUCTS IN THIS MANUAL ARE SUBJECT TO CHANGE WITHOUT NOTICE. ALL STATEMENTS, INFORMATION, AND RECOMMENDATIONS IN THIS MANUAL ARE BELIEVED TO BE ACCURATE BUT ARE PRESENTED WITHOUT WARRANTY OF ANY KIND, EXPRESS OR IMPLIED. USERS MUST TAKE FULL RESPONSIBILITY FOR THEIR APPLICATION OF ANY PRODUCTS.

THE SOFTWARE LICENSE AND LIMITED WARRANTY FOR THE ACCOMPANYING PRODUCT ARE SET FORTH IN THE INFORMATION PACKET THAT SHIPPED WITH THE PRODUCT AND ARE INCORPORATED HEREIN BY THIS REFERENCE. IF YOU ARE UNABLE TO LOCATE THE SOFTWARE LICENSE OR LIMITED WARRANTY, CONTACT YOUR CISCO REPRESENTATIVE FOR A COPY.

The Cisco implementation of TCP header compression is an adaptation of a program developed by the University of California, Berkeley (UCB) as part of UCB's public domain version of the UNIX operating system. All rights reserved. Copyright © 1981, Regents of the University of California.

NOTWITHSTANDING ANY OTHER WARRANTY HEREIN, ALL DOCUMENT FILES AND SOFTWARE OF THESE SUPPLIERS ARE PROVIDED "AS IS" WITH ALL FAULTS. CISCO AND THE ABOVE-NAMED SUPPLIERS DISCLAIM ALL WARRANTIES, EXPRESSED OR IMPLIED, INCLUDING, WITHOUT LIMITATION, THOSE OF MERCHANTABILITY, FITNESS FOR A PARTICULAR PURPOSE AND NONINFRINGEMENT OR ARISING FROM A COURSE OF DEALING, USAGE, OR TRADE PRACTICE.

IN NO EVENT SHALL CISCO OR ITS SUPPLIERS BE LIABLE FOR ANY INDIRECT, SPECIAL, CONSEQUENTIAL, OR INCIDENTAL DAMAGES, INCLUDING, WITHOUT LIMITATION, LOST PROFITS OR LOSS OR DAMAGE TO DATA ARISING OUT OF THE USE OR INABILITY TO USE THIS MANUAL, EVEN IF CISCO OR ITS SUPPLIERS HAVE BEEN ADVISED OF THE POSSIBILITY OF SUCH DAMAGES.

Cisco and the Cisco logo are trademarks or registered trademarks of Cisco and/or its affiliates in the U.S. and other countries. To view a list of Cisco trademarks, go to this URL: www.cisco.com/go/trademarks. Third-party trademarks mentioned are the property of their respective owners. The use of the word partner does not imply a partnership relationship between Cisco and any other company. (1110R)

Any Internet Protocol (IP) addresses and phone numbers used in this document are not intended to be actual addresses and phone numbers. Any examples, command display output, network topology diagrams, and other figures included in the document are shown for illustrative purposes only. Any use of actual IP addresses or phone numbers in illustrative content is unintentional and coincidental.

High Availability Installation Guide for Cisco Security Manager 4.9
© 2015 Cisco Systems, Inc. All rights reserved.



Preface vii

Audience ii-vii

Conventions ii-viii

Related Documentation ii-ix

Obtaining Documentation and Submitting a Service Request ii-x

ii-x

CHAPTER 1

Overview 1-1

Local Redundancy (HA) Process Overview 1-1

Local Redundancy (HA) Configuration Steps 1-2

Geographic Redundancy (DR) Process Overview 1-3

Geographic Redundancy (DR) Configuration Steps 1-4

Symantec Veritas Products 1-5

CHAPTER 2

System Requirements 2-1

Hardware Requirements for a Single-Node Site 2-1

Hardware Requirements for a Dual-Node Site 2-2

Software Requirements for a Local Redundancy Configuration 2-3

Software Requirements for a Geographic Redundancy (DR) Configuration 2-4

Software Requirements for Replication without Clustering 2-4

Preinstallation Worksheets 2-5

Local Redundancy Configuration Worksheet 2-5

Geographic Redundancy (DR) Configuration Worksheet 2-6

CHAPTER 3

Installing the Cisco Security Management Suite High Availability Solution 3-1

Making Ethernet Connections 3-1

Installing Microsoft Windows Server 3-2

Connecting the Servers to External Storage 3-2

Installing Symantec Veritas Products 3-2

Mirroring the Boot Disk (Optional) 3-3

Veritas Volume Manager Configuration Tasks 3-4

- Primary Server (without Replication) 3-4
- Primary Servers (with Replication) 3-5
- Secondary Servers and the Primary Server in a Secondary Cluster 3-6
- Installing Security Manager 3-6
 - Installing Security Manager on the Primary Server 3-7
 - Installing Security Manager on Secondary Servers 3-9
 - Manually Starting Services in Secondary HA Server 3-11
- Veritas Volume Replicator Tasks 3-12
- Updating Permissions on the Working Volume 3-14
 - Updating Permissions when using Shared Storage 3-14
 - Updating Permissions when using Replication 3-15
- Veritas Cluster Server Tasks 3-16
 - Single Local Cluster (Dual-Node) Configuration 3-16
 - Creating the Cluster 3-16
 - Creating the Application Service Group 3-17
 - Creating the ClusterService Group (Optional) 3-23
 - Dual Geographic Cluster Configuration 3-24
 - Creating the Primary and Secondary Clusters 3-24
 - Creating the ClusterService Group 3-25
 - Creating the Replication Service Group 3-26
 - Creating the Application Service Group 3-27
 - Creating the Cluster Level Configuration 3-29

CHAPTER 4

- Maintenance Activities 4-1**
 - Customizing VCS Behavior 4-1
 - Security Certificates for SSL 4-2
 - Manually Starting, Stopping, or Failing Over Security Manager 4-3
 - VCS Case 4-3
 - Non-VCS Case 4-4
 - Integrating Cisco Secure ACS with Security Manager 4-5
 - Upgrading Security Manager 4-6
 - Backing Up Security Manager 4-6
 - Uninstalling Security Manager 4-6
 - Migrating a Non-HA Security Manager to HA 4-8

APPENDIX A

- VCS Resource Views for the Reference Configurations A-1**
 - Single Local Cluster (Dual-Node) Configuration A-2
 - Dual Geographic Cluster (Single-Node) Configuration A-3

APPENDIX B**High Availability and Disaster Recovery Certification Test Plan B-1**Manual Switches **B-1**IntraCluster Switch **B-1**InterCluster Switch **B-2**Ethernet/Network Failures **B-3**Network Communication Failures **B-3**Network Ethernet Failure on Secondary Server, Single Cluster **B-3**Network Ethernet Failure on Primary Server, Single Cluster **B-4**Network Ethernet Failure on Secondary Server, Dual Cluster **B-5**Network Ethernet Failure on Primary Server, Dual Cluster **B-7**Cluster Communication Failure **B-8**Server Failures **B-10**Standby Server Failure, Single Cluster **B-10**Primary Server Failure, Single Cluster **B-11**Standby Server Failure, Dual Cluster **B-12**Primary Server Failure, Dual Cluster **B-14**Application Failures **B-16**Application Failure, Single Cluster **B-16**Application Failure, Dual Cluster **B-17**

INDEX



Preface

This document explains how to install Cisco Security Management Suite (Security Manager) in a high availability (HA) or disaster recovery (DR) environment. The Security Manager HA/DR solution is based on Symantec’s Veritas Storage Foundation and High Availability solutions.

Audience

The primary audience for this guide is system administrators who are responsible for installing and managing the HA/DR solutions. This guide assumes that you are familiar with the topics in [Table 1](#).

Table 1 **Topics in this Guide**

Configuration	Topics
Local Redundancy	<ul style="list-style-type: none"> • Cisco Security Management Suite • Microsoft Windows Server 2012, Standard and Datacenter Edition, or Microsoft Windows Server 2012 R2, Standard and Datacenter Edition • Symantec Veritas Storage Foundation HA for Windows 6.0.1, 6.0.2 or 6.1
Geographic Redundancy	<ul style="list-style-type: none"> • Cisco Security Management Suite • Microsoft Windows Server 2012, Standard and Datacenter Edition, or Microsoft Windows Server 2012 R2, Standard and Datacenter Edition • Symantec Veritas Storage Foundation HA/DR for Windows 6.0.1, 6.0.2, or 6.1 • Symantec Veritas Volume Replicator Option
Geographic Redundancy without Clustering	<ul style="list-style-type: none"> • Cisco Security Management Suite • Microsoft Windows Server 2012, Standard and Datacenter Edition, or Microsoft Windows Server 2012 R2, Standard and Datacenter Edition • Symantec Veritas Storage Foundation Basic for Windows 6.0.1, 6.0.2, or 6.1 • Symantec Veritas Volume Replicator Option

Because the Security Manager HA/DR solution utilizes Symantec’s Veritas Storage Foundation and High Availability Solutions for Windows, we highly recommend the following Symantec courses for a local redundancy solution:

- Veritas Storage Foundation for Windows
- Veritas Cluster Server for Windows

For a geographically redundant solution, the following additional courses are highly recommended:

- Veritas Volume Replicator for Windows
- Disaster Recovery Using Veritas Volume Replicator and Global Cluster Option for Windows

For more information, please refer to the Symantec website.

Conventions

This document uses the following conventions:

Item	Convention
Commands, keywords, special terminology, and options that should be selected during procedures	boldface font
Variables for which you supply values and new or important terminology	<i>italic font</i>
Displayed session and system information, paths and file names	screen font
Information you enter	boldface screen font
Variables you enter	<i>italic screen font</i>
Menu items and button names	boldface font
Indicates menu items to select, in the order you select them.	Option > Network Preferences



Tip

Identifies information to help you get the most benefit from your product.



Note

Means *reader take note*. Notes identify important information that you should reflect upon before continuing, contain helpful suggestions, or provide references to materials not contained in the document.



Caution

Means *reader be careful*. In this situation, you might do something that could result in equipment damage, loss of data, or a potential breach in your network security.



Warning

Identifies information that you must heed to prevent damaging yourself, the state of software, or equipment. Warnings identify definite security breaches that will result if the information presented is not followed carefully.

Related Documentation

Refer to the following Cisco publications for additional information. These documents are available at <http://www.cisco.com/c/en/us/support/security/security-manager/tsd-products-support-series-home.html>.

- *Installation Guide for Cisco Security Manager 4.9*
- *User Guide for Cisco Security Manager 4.9*
- *Release Notes for Cisco Security Manager 4.9*

Refer to the following Symantec publications for additional information concerning Veritas Storage Foundation:

- *Veritas Storage Foundation™ and High Availability Solutions Getting Started Guide*
- *Veritas Storage Foundation™ and High Availability Solutions Release Notes*
- *Veritas Storage Foundation™ and High Availability Solutions Installation and Upgrade Guide*
- *Veritas Storage Foundation™ Administrator's Guide*
- *Veritas™ Cluster Server Release Notes*
- *Veritas™ Cluster Server Installation and Upgrade Guide*
- *Veritas™ Cluster Server Bundled Agents Reference Guide*
- *Veritas™ Cluster Server Administrator's Guide*
- *Veritas™ Volume Replicator Administrator's Guide*
- *Veritas™ Volume Replicator Advisor User's Guide*
- *Hardware Compatibility List (HCL) for Veritas Storage Foundation™ and High Availability Solutions for Windows*
- *Software Compatibility List (SCL) for Veritas Storage Foundation™ and High Availability Solutions for Windows*

Obtaining Documentation and Submitting a Service Request

For information on obtaining documentation, using the Cisco Bug Search Tool (BST), submitting a service request, and gathering additional information, see *What's New in Cisco Product Documentation* at: <http://www.cisco.com/c/en/us/td/docs/general/whatsnew/whatsnew.html>.

Subscribe to *What's New in Cisco Product Documentation*, which lists all new and revised Cisco technical documentation as an RSS feed and delivers content directly to your desktop using a reader application. The RSS feeds are a free service.





Overview

This document explains how to install Cisco Security Management Suite (Security Manager) in a high availability (HA) or disaster recovery (DR) environment. The Security Manager HA/DR solution is based on Symantec's Veritas Storage Foundation and High Availability solutions. The Security Manager HA/DR solutions described in this guide support the following applications:

- Security Manager 4.9
- Auto Update Server (AUS) 4.9



Note Since devices contact the AUS server directly using the AUS server IP address, it is necessary for the device to support defining up to two AUS servers for a DR configuration, where the AUS server at each site has a different IP address. Defining more than one AUS server IP address is supported only by the ASA 5500 Series beginning with release 7.2.1.

The HA solution supports both local redundancy (HA) and geographic redundancy (DR) configurations.



Note

Cross-launching the Cisco Prime Security Manager (PRSM) application is supported in both HA and DR configurations; however, seamless, direct access to PRSM from Security Manager using the “single sign-on” (SSO) feature is only supported in HA mode.

This section provides the following overviews:

- [Local Redundancy \(HA\) Process Overview, page 1-1](#)
- [Geographic Redundancy \(DR\) Process Overview, page 1-3](#)
- [Symantec Veritas Products, page 1-5](#)

Local Redundancy (HA) Process Overview

The local redundancy configuration provides an automatic failover solution in the event of software or hardware failures without the need to reconfigure IP addresses or DNS entries on your switched/routed network.

Figure 1-1 illustrates the local redundancy HA configuration.



Note

The servers in Figure 1-1 optionally contain mirrored internal boot disks. We recommend that they be the same make, model, and storage capacity. We recommend a fault-tolerant switched/routed network for communicating with the HA servers.

Figure 1-1 Local Redundancy HA Configuration

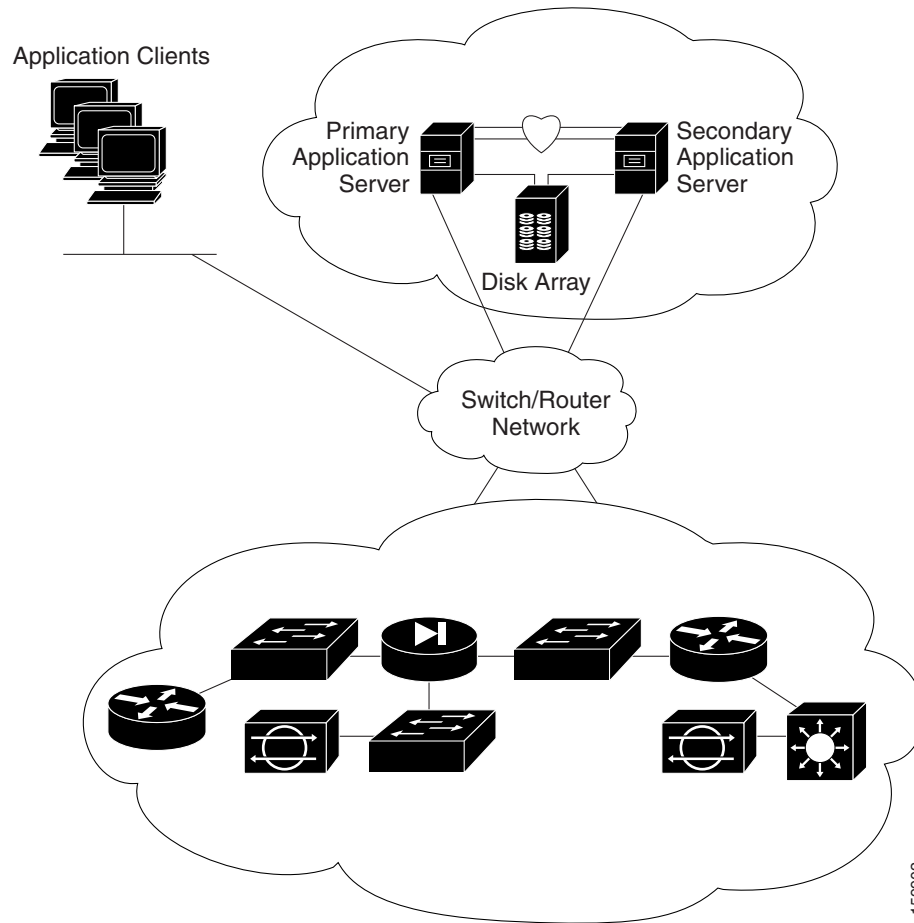

159902

Local Redundancy (HA) Configuration Steps

The following table lists the steps required to configure a locally redundant installation of Cisco Security Manager.

	Task	References
Step 1	Make physical connections.	Making Ethernet Connections, page 3-1
Step 2	Install Microsoft Windows Server and all necessary drivers.	Installing Microsoft Windows Server, page 3-2

	Task	References
Step 3	Make storage connections.	Connecting the Servers to External Storage, page 3-2
Step 4	Install and configure the Symantec Veritas products and components.	Installing Symantec Veritas Products, page 3-2
Step 5	Mirror the boot disk.	Mirroring the Boot Disk (Optional), page 3-3
Step 6	Setup required volumes on the shared array.	Veritas Volume Manager Configuration Tasks, page 3-4
Step 7	Install Cisco Security Manager on the shared volume on the primary server.	Installing Security Manager, page 3-6
Step 8	Install Cisco Security Manager on the spare (dummy) volume on the secondary server.	Installing Security Manager, page 3-6
Step 9	Update permissions on secondary server.	Updating Permissions on the Working Volume, page 3-14
Step 10	Create and configure clusters.	Veritas Cluster Server Tasks, page 3-16

Geographic Redundancy (DR) Process Overview

The geographic redundancy configuration provides disaster recovery by replicating application data between two sites. Failover between sites can be initiated manually or performed automatically.

[Figure 1-2](#) illustrates a geographic redundancy (DR) configuration.



Note

The servers in [Figure 1-2](#) optionally contain mirrored internal boot disks. We recommend that they be the same make, model, and storage capacity. We recommend a fault-tolerant switched/routed network for communicating with the servers.

Figure 1-2 Geographic Redundancy (DR) Configuration

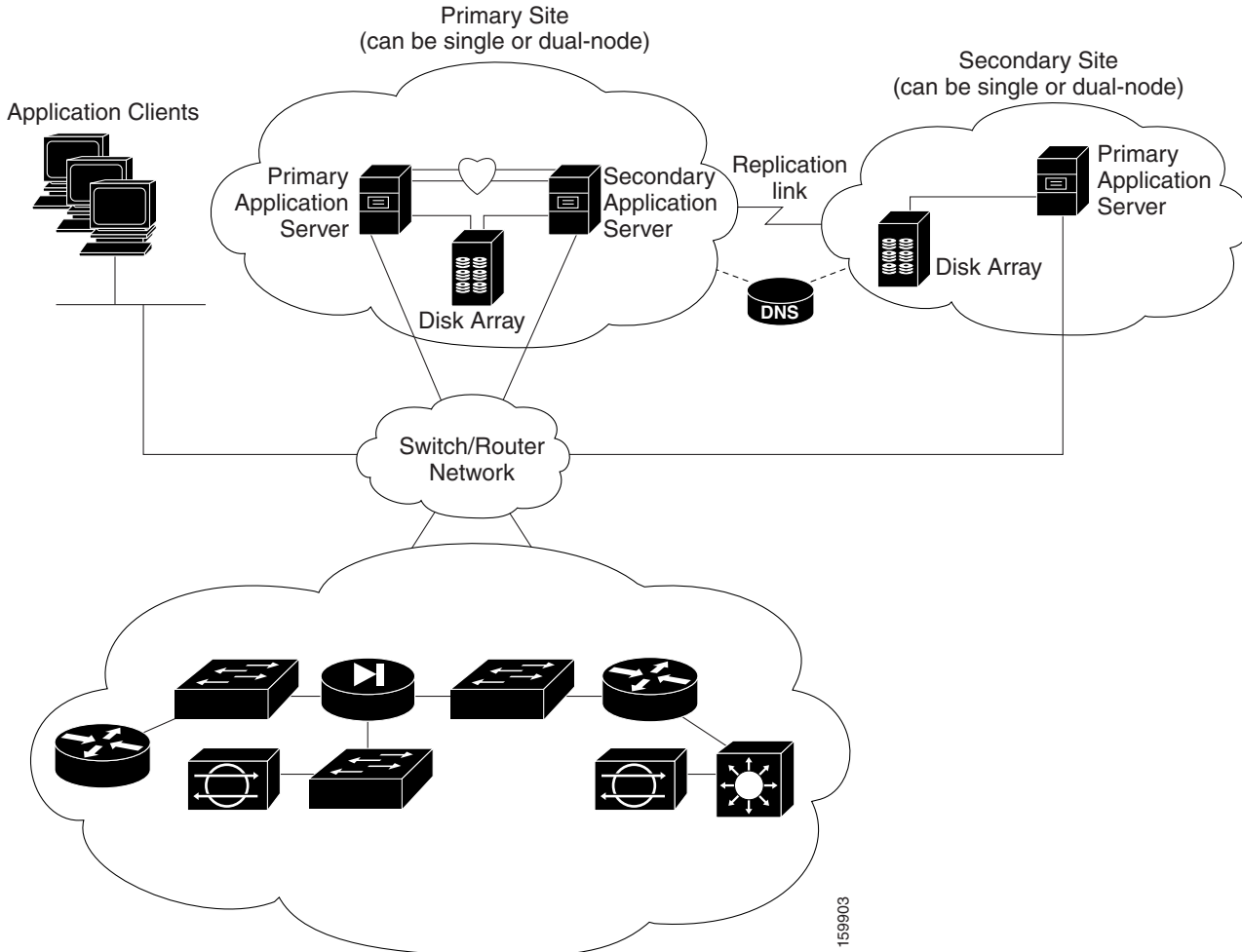

Geographic Redundancy (DR) Configuration Steps

The following table lists the steps required to configure a geographically redundant installation of Cisco Security Manager.

	Task	References
Step 1	Make physical connections.	Making Ethernet Connections, page 3-1
Step 2	Install Microsoft Windows Server and all necessary drivers.	Installing Microsoft Windows Server, page 3-2
Step 3	Make storage connections.	Connecting the Servers to External Storage, page 3-2
Step 4	Install and configure the Symantec Veritas products and components.	Installing Symantec Veritas Products, page 3-2
Step 5	Mirror the boot disk.	Mirroring the Boot Disk (Optional), page 3-3

	Task	References
Step 6	Setup required volumes on the shared array.	Veritas Volume Manager Configuration Tasks, page 3-4
Step 7	Install Cisco Security Manager on the shared volume on the primary server.	Installing Security Manager, page 3-6
Step 8	Install Cisco Security Manager on the spare (dummy) volume on the secondary server.	Installing Security Manager, page 3-6
Step 9	Configure replication.	Veritas Volume Replicator Tasks, page 3-12
Step 10	Update permissions on secondary server.	Updating Permissions on the Working Volume, page 3-14
Step 11	Create and configure clusters.	Veritas Cluster Server Tasks, page 3-16

Symantec Veritas Products

The Security Manager HA/DR solutions described in this document are based on Symantec Veritas products. This section gives a brief summary of each specific Veritas application.

- Veritas Storage Foundation for Windows (VSWF)

VSWF provides volume management technology, quick recovery, and fault tolerant capabilities to Windows enterprise computing environments. VSWF provides the foundation for VCS and VVR.
- Veritas Cluster Server (VCS)

VCS is a clustering solution for reducing application downtime. The Global Cluster Option (GCO) for VCS supports managing multiple clusters (such as used in a DR configuration).
- Veritas Volume Replicator (VVR)

VVR provides a foundation for continuous data replication over IP networks, enabling rapid and reliable recovery of critical applications at remote recovery sites.
- Veritas Enterprise Administrator (VEA GUI) console

The VEA GUI console window provides a graphical way to view and manipulate all the storage objects in your system.
- Cluster Manager (Java Console)

Cluster Manager (Java Console) offers complete administration capabilities for your cluster. Use the different views in the Java Console to monitor clusters and VCS objects, including service groups, systems, resources, and resource types:

 - Cluster Monitor

Cluster Monitor displays general information about actual or simulated clusters. Use Cluster Monitor to log on to and off of a cluster, view summary information on various VCS objects, customize the display, use VCS Simulator, and exit Cluster Manager.
 - Cluster Explorer

Cluster Explorer is the main window for cluster administration. From this window, you can view the status of VCS objects and perform various operations.



System Requirements

This chapter describes reference configurations for installing Security Manager in an HA or DR environment. This chapter contains the following sections:

- [Hardware Requirements for a Single-Node Site, page 2-1](#)
- [Hardware Requirements for a Dual-Node Site, page 2-2](#)
- [Software Requirements for a Local Redundancy Configuration, page 2-3](#)
- [Software Requirements for a Geographic Redundancy \(DR\) Configuration, page 2-4](#)
- [Software Requirements for Replication without Clustering, page 2-4](#)
- [Preinstallation Worksheets, page 2-5](#)



Note

There are numerous configurations possible using different hardware setups. Consult the respective Microsoft and Symantec/Veritas Hardware Compatibility Lists (HCLs).



Note

Although we make every attempt to ensure the availability of third-party hardware and software platforms specified for Security Manager, we reserve the right to change or modify system requirements due to third-party vendor product availability or changes that are beyond our control.

Hardware Requirements for a Single-Node Site

To install Security Manager in a single-node HA environment, you can configure a fault-tolerant storage array or use internal disks.

The following are the server hardware specifications for a single-node site:

- Server which meets the basic processor and RAM requirements as described in the *Installation Guide for Cisco Security Manager 4.9*
- Minimum of one Ethernet interface (two recommended)
- Minimum of two physical drives (six recommended)

[Figure 2-1](#) shows using two Ethernet connections from the server to the switch/router network for redundancy. If an Ethernet port or switch fails, communication to the server is maintained. If this level of network redundancy is not required, you can use a single connection to the switch/router network (that is, Eth 2 and its associated Ethernet switch are optional).

Figure 2-1 Ethernet Connections for a Single-Node Site

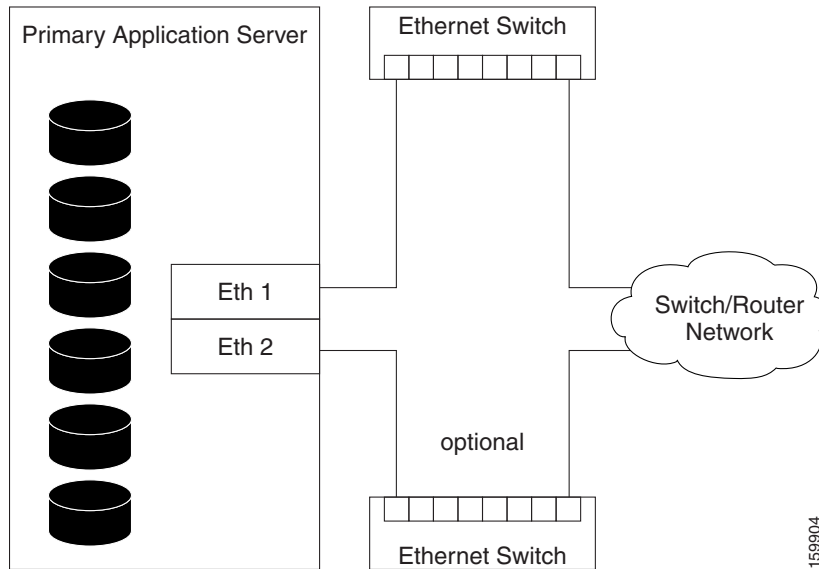

Hardware Requirements for a Dual-Node Site

To install Security Manager in a dual-node HA environment, you need two servers that can access a shared storage array.

The following are the server hardware specifications for a dual-node site:

- Servers that meet the basic processor and RAM requirements, as described in the *Installation Guide for Cisco Security Manager 4.9*
- Minimum of two Ethernet interfaces (four recommended)
- Minimum of one internal physical drive (two recommended)
- Minimum of one external drive (two recommended; four recommended if using replication)

Figure 2-2 depicts the configuration of a dual-node site showing the Ethernet and external storage connections. Two Ethernet connections are used from the server to the switch/router network for redundancy. If an Ethernet port or switch fails, communications to the server is maintained. If this level of network redundancy is not required, you can use a single connection to the switch/router network (that

is, Eth 4 and its associated Ethernet switch are optional). Two direct Ethernet connections are made between the servers for cluster heartbeat communications, although second heartbeat connection (Eth 3) is optional.

Figure 2-2 *Ethernet and Storage Connections for a Dual-Node Site*

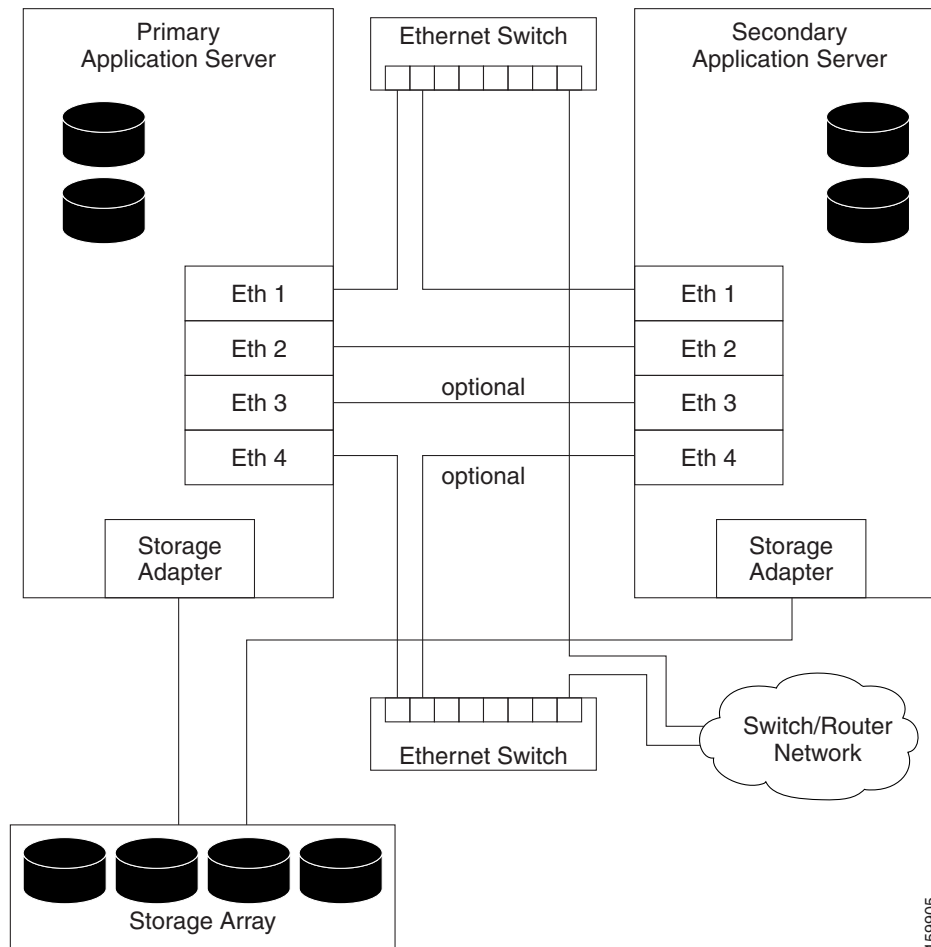

Software Requirements for a Local Redundancy Configuration

The following software is required to install Security Manager in a local redundancy HA configuration:

- Cisco Security Management Suite 4.9
- Microsoft Windows Server 2012, Standard and Datacenter Edition, or Microsoft Windows Server 2012 R2, Standard and Datacenter Edition
- Symantec Veritas Storage Foundation HA for Windows versions 6.0.1 / 6.0.2 / 6.1
- Symantec Dynamic Multipathing Option

A Security Manager license is only required for the active server in a HA/DR configuration. Additional licenses for standby servers are not required.

Veritas Storage Foundation HA for Windows is licensed on a per-node basis. In the same local redundancy configuration example, each server needs to have its own license for running Veritas Storage Foundation HA for Windows.

The Veritas Dynamic Multipathing Option is required only if you plan to use external storage with more than one host bus adapter in a server, which provides multiple paths between the server and storage.

Software Requirements for a Geographic Redundancy (DR) Configuration

The following software is required to install Security Manager in a geographic redundancy (DR) configuration:

- Cisco Security Management Suite 4.9
- Microsoft Windows Server 2012, Standard and Datacenter Edition, or Microsoft Windows Server 2012 R2, Standard and Datacenter Edition
- Symantec Veritas Storage Foundation HA/DR for Windows 6.0.1/ 6.0.2/ 6.1
- Symantec Veritas Volume Replicator Option
- Symantec Veritas Dynamic Multipathing Option

Security Manager is licensed per active server in an HA/DR configuration. For example, in a geographic redundancy configuration with a single-node cluster at site A and a single-node cluster at Site B, you only need to purchase one copy of Security Manager, since Security Manager is only active on one server at any given time.

Veritas Storage Foundation HA for Windows is licensed on a per-node basis. In the same geographic redundancy configuration example with two servers (one per cluster), each server needs to have its own license for running Veritas Storage Foundation HA for Windows.

The Veritas Volume Replicator Option is licensed on a per-node basis.

The Veritas Dynamic Multipathing Option is required only if you plan to use external storage with more than one host bus adapter in a server, which provides multiple paths between the server and storage.

Software Requirements for Replication without Clustering

The following software is required to install Security Manager in a geographic redundancy (DR) configuration without clustering:

- Cisco Security Management Suite 4.9
- Microsoft Windows Server 2012, Standard and Datacenter Edition, or Microsoft Windows Server 2012 R2, Standard and Datacenter Edition
- Symantec Veritas Storage Foundation Basic for Windows 6.0.1 / 6.0.2 / 6.1
- Symantec Veritas Volume Replicator Option
- Symantec Veritas Dynamic Multipathing Option

Security Manager is licensed for each active server in a HA/DR configuration. For example, in a geographic redundancy configuration with replication running between a primary server and a secondary server, you need to purchase only one copy of Security Manager, because Security Manager is active on only one server at any given time.

Veritas Storage Foundation for Windows is licensed on a per-node basis. In the same geographic redundancy configuration example with two servers, each server must have its own license for running Veritas Storage Foundation for Windows.

Veritas Storage Foundation Basic for Windows versions 6.0.1 / 6.0.2 / 6.1 work with up to four volumes and are available for free download from Symantec.

The Veritas Volume Replicator Option is licensed on a per-node basis.

The Veritas Dynamic Multipathing Option is required only if you plan on using external storage with more than one host bus adapter in a server, which provides multiple paths between the server and storage.

Preinstallation Worksheets

Use the preinstallation worksheet to plan your installation and to gather the information you will need during configuration. This section contains the following topics:

- [Local Redundancy Configuration Worksheet, page 2-5](#)
- [Geographic Redundancy \(DR\) Configuration Worksheet, page 2-7](#)

Local Redundancy Configuration Worksheet

Before you install Security Manager in a local redundancy HA configuration, write down the information outlined in [Table 2-1](#) to assist you in completing the installation.

Table 2-1 Preinstallation Worksheet for a Local Redundancy Configuration

Information	Primary Site	
Shared Disk Group Name	datadg	
Shared Volume Name	cscopx	
Drive Letter for Security Manager Data		
Shared Disk Group Name for Event Data ¹	datadg_evt	
Shared Volume Name for Event Data ¹	cscopx_evt	
Drive Letter for Security Manager Event Data ¹		
Cluster Name	CSManager_Primary	
Cluster ID	0 ²	
Security Manager Virtual IP Address/Subnet mask		
Cluster Service Virtual IP Address/Subnet mask ³		
	Primary Server	Secondary Server
Hostname		
Public Network Interface #1 and IP Address/Subnet Mask		
Public Network Interface #2 ⁴ and IP Address/Subnet Mask		
Private Cluster Interconnect #1		
Private Cluster Interconnect #2		

1. Optional: Use these fields if you want your event data stored separately.
2. Must be an integer between 0 and 255 and unique for clusters in the same subnet.
3. This is the same value as the Security Manager Virtual IP Address/Subnet mask.
4. Required if a second NIC will be used to access the public network for redundancy.

Geographic Redundancy (DR) Configuration Worksheet

If you are installing Security Manager in a geographic redundancy (DR) configuration, write down the information outlined in [Table 2-2](#) to assist you in completing the installation.

Table 2-2 Preinstallation Worksheet for a Geographic Redundancy (DR) Configuration

Information	Primary Site		Secondary Site	
Disk Group	datadg		datadg	
Data Volume	cscopx		cscopx	
Drive Letter for Security Manager				
Disk Group for Event Data ¹	datadg_evt		datadg_evt	
Data Volume for Event Data	cscopx_evt		cscopx_evt	
Drive Letter for Event Data				
Storage Replicator Log Volume	data_srl		data_srl	
Replicated Data Set	CSM_RDS			
Replicated Volume Group	CSM_RVG			
Cluster Name	CSManager_Primary		CSManager_Secondary	
Cluster ID	0 ²		1 ²	
Security Manager Virtual IP Address/Subnet Mask				
Replication Virtual IP Address/Subnet Mask				
Cluster Service Virtual IP Address/Subnet Mask ^{3,4}				
	Primary Server	Secondary Server	Primary Server	Secondary Server
Hostname				
Public Network Interface #1 and IP Address/Subnet Mask				
Public Network Interface #2 and IP Address/Subnet Mask ⁵				
Private Cluster Interconnect #1 ⁶				
Private Cluster Interconnect #2 ⁶				

- Optional: Use these fields if you want your event data stored separately.
- Must be an integer between 0 and 255 and unique for clusters in the same subnet.
- Required only for clusters using two servers or multiple adapters to access the public network. For a single server cluster with only one network adapter to access the public network, the fixed IP address of this adapter can be used.
- This is the same value as the Security Manager Virtual IP Address/Subnet mask.
- Required if you are using a second NIC to access the public network for redundancy.
- Required only for clusters using two servers.



Installing the Cisco Security Management Suite High Availability Solution

This chapter explains how to install Security Manager in an HA or DR deployment configuration. You should perform these tasks in order, although some tasks are optional or might not apply depending on your specific configuration.

This chapter contains the following topics:

- [Making Ethernet Connections, page 3-1](#)
- [Installing Microsoft Windows Server, page 3-2](#)
- [Connecting the Servers to External Storage, page 3-2](#)
- [Installing Symantec Veritas Products, page 3-2](#)
- [Mirroring the Boot Disk \(Optional\), page 3-3](#)
- [Veritas Volume Manager Configuration Tasks, page 3-4](#)
- [Installing Security Manager, page 3-6](#)
- [Veritas Volume Replicator Tasks, page 3-12](#)
- [Updating Permissions on the Working Volume, page 3-14](#)
- [Veritas Cluster Server Tasks, page 3-16](#)

Making Ethernet Connections

To make the Ethernet connections required by your HA or DR configuration, follow these steps:

- Step 1** Make the Ethernet connections between the servers and switches according to [Figure 2-1](#) or [Figure 2-2](#), depending on your cluster configuration.



Note Use of a second Ethernet connection to the router/switch network for each server is optional, but it adds an extra level of redundancy in the event of a NIC or local Ethernet switch failure. Veritas Cluster Server (VCS) includes the IPMultiNicPlus agent. This agent allows setting up multiple NIC cards on a server which provides redundant access for the server to the router/switch network. If a NIC card fails, a cable is removed, or some other failure occurs, VCS can detect the failure and reassign the working virtual IP address to another working NIC card on the server.

See the Veritas Cluster Server Bundled Agents Reference Guide for details on the IPMultiNicPlus agent. The examples in this document only show the case of a single NIC card for network access.

You can also use vendor specific NIC teaming (IEEE 802.3ad link aggregation) solutions as an alternative.

- Step 2** In the case of a dual-node cluster, make the Ethernet cluster communication connections between the servers according to [Figure 2-2](#). When connecting directly between servers, you might not have to use a crossover Ethernet cable, depending on whether the interfaces support automatic crossover detection. Most newer Ethernet interfaces support this feature and allow using a straight-through cable when directly connecting to another server.

Installing Microsoft Windows Server

Install the supported Microsoft Windows operating system:

Microsoft Windows Server 2012, Standard and Datacenter Edition

Microsoft Windows Server 2012 R2, Standard and Datacenter Edition

We recommend that you use the same operating system on all servers.



Note

Symantec Veritas Storage Foundation HA for Windows version 6.0.1 / 6.0.2 / 6.1 requires that you install the operating system in the same path on all systems. For example, if you install Windows on C:\WINDOWS of one node, installations on all other nodes must be on C:\WINDOWS. Make sure that the same drive letter is available on all nodes and that the system drive has adequate space for the installation.

Connecting the Servers to External Storage

If you are using a dual-node cluster, shared external storage is required. You may use any storage hardware in *Hardware Compatibility List for Veritas Storage Foundation & High Availability Solutions for Windows*. Either internal or external storage can be used for a single-node cluster.

Installing Symantec Veritas Products

Install and configure the Symantec Veritas products and components. The products and components required vary depending on whether a single local cluster, dual geographic clusters, or replication without clustering configuration is used. Some components are optional, such as the GUI for Volume Manager (Veritas Enterprise Administrator). See [Table 3-1](#).

Table 3-1 Veritas Software Components

Veritas Product/Component	Single Local Cluster	Dual Geographic Clusters	Replication without Clustering
Storage Foundation for Windows	—	—	Required
Symantec Veritas Storage Foundation HA for Windows version 6.0.1 / 6.0.2 / 6.1	Required	Required	—
Volume Replicator Option	Not Required	Required	Required
Global Cluster Option	Not Required	Required	—
Dynamic Multipathing Option	See Note ¹	See Note ¹	See Note ¹
Veritas Enterprise Administrator (GUI) ²	Required	Required	Required
Cluster Manager (GUI) ²	Optional	Optional	—

1. Required only if you are using external storage with multiple host bus adapters providing multiple paths between the server and disk storage
2. Can be installed either on the server or a separate client machine.

See the applicable Veritas release notes and installation guides for prerequisites and instructions for installing the Veritas software.

**Note**

One important prerequisite is that you configure the servers as part of a Windows Server domain.

Mirroring the Boot Disk (Optional)

Mirroring the boot disk is optional; however, it provides an extra level of protection for a given server. If the boot disk fails, the machine can be recovered quickly by booting from the mirrored alternate boot disk. Mirroring is accomplished by placing the boot disk in a dynamic disk group under Veritas Volume Manager control and then adding a mirror.

See the section called “Set up a Dynamic Boot and System Volume” in the Symantec Veritas Storage Foundation HA for Windows version 6.0.1 / 6.0.2 / 6.1 administrator’s guide for details on this procedure.

Veritas Volume Manager Configuration Tasks

In this section, you configure the necessary disk group and volumes required for the Security Manager application. The configuration varies depending on whether the server involved is the primary server or a secondary server and whether or not replication is involved. You can perform Volume Manager tasks with the VEA GUI or through the command line. For details on using VEA or the command line for these steps, see the Symantec Veritas Storage Foundation HA for Windows version 6.0.1 / 6.0.2 / 6.1 administrator's guide.

This section contains the following topics:

- [Primary Server \(without Replication\), page 3-4](#)
- [Primary Servers \(with Replication\), page 3-5](#)
- [Secondary Servers and the Primary Server in a Secondary Cluster, page 3-6](#)

Primary Server (without Replication)

Use this procedure to configure the disk group and volumes required for Security Manager on the primary server in a single-cluster configuration where replication is not involved. In a single-cluster configuration, external shared storage is used, which is accessible to all servers in the cluster.

To configure the disk group and volumes, follow these steps:

Step 1 Create a disk group with the following characteristics:

- Group Name: **datadg**
- Type: **Dynamic (Cluster)**
- Number of Disks: If using software RAID, include at least two disks in the group for mirroring; otherwise, a single logical disk (using hardware RAID) is sufficient. The disks used for this disk group must be accessible to all nodes in the cluster.



Note The use of software RAID 5 is not recommended.

Step 2 Create a volume in the **datadg** disk group with the following characteristics:

- Volume Name: **cscopx**
- Assigned Drive Letter: **<Selected Drive Letter>**



Note You can choose any available drive letter; however, the drive letter must be the same on all systems.

- File Type: **NTFS**
-

Primary Servers (with Replication)

Use this procedure to configure the disk group and volumes required for Security Manager on the primary servers in a dual geographic configuration where replication is running between the two clusters. Perform this procedure on the primary server in both the primary and secondary cluster. For each cluster you can use either a single-node cluster or a cluster with multiple nodes using shared storage; however, this document does not cover the case of a multi-node cluster in a dual geographic configuration.

To configure the disk group and volumes, follow these steps:

-
- Step 1** Create a disk group with the following characteristics:
- Group Name: **datadg**
 - Type: **Dynamic (Cluster)** (when using VCS), **Dynamic (Secondary)** (when not using VCS)
 - Number of Disks: If using software RAID, include at least two disks in the group for mirroring; otherwise, a single logical disk (which uses hardware RAID) is sufficient. If this is a multi-node cluster, the disks used for this disk group must be accessible to all nodes in the cluster.
-  **Note** The use of software RAID 5 is not recommended.
-
- Step 2** Create a volume in the **datadg** disk group with the following characteristics:
- Volume Name: **cscoptx**
 - Assigned Drive Letter: **<Selected Drive Letter>** (for the primary cluster), **None** (for the secondary cluster)
 - File Type: **NTFS** (for the primary cluster), **None** (for the secondary cluster)
 - Volume Logging: **None**
- Step 3** Create a volume in the **datadg** disk group for use as a storage replicator log (SRL) with the following characteristics:
- Volume Name: **data_srl**
 - Assigned Drive Letter: **None**
 - File Type: **Unformatted**
 - Volume Logging: **None**



Note For information on choosing the proper size of the SRL, see the Volume Replicator administrator's guide.

Secondary Servers and the Primary Server in a Secondary Cluster

Use this procedure to configure the disk group and volumes required for installing Security Manager on secondary servers and on the primary server in a secondary cluster. You must install Security Manager on all secondary servers, as well as the primary server in a secondary cluster. In these cases, you install Security Manager on a spare volume, which is mounted temporarily before installation, then dismounted and not used again until you want to uninstall Security Manager from the server or you want to upgrade Security Manager. You must mount the temporary volume on the same drive letter as the one used for the primary server in the primary cluster and you must use the same installation path (for example, F:\Program Files\CSCOpX) during the installation.

To configure the disk group and volumes, follow these steps:

-
- Step 1** If you are not creating the spare volume on an existing disk group, create a disk group with the following characteristics:
- Group Name: **datadg_spare**
 - Type: **Dynamic (Secondary)**
 - Size: **5GB** (The volume only needs to be large enough to install Security Manager)
 - Number of Disks: Since this disk group is not used to store application data, a single, nonredundant disk is sufficient.
- Step 2** Create a volume in the disk group with the following characteristics:
- Volume Name: **cscopx_spare**
 - Assigned Drive Letter: **<Selected Drive Letter>**



Note You **must** use the same drive letter that is used for the cscopx drive on the primary server.

- File Type: **NTFS**
-

Installing Security Manager

The Security Manager installer detects the presence of Symantec Veritas Storage Foundation HA for Windows version 6.0.1 / 6.0.2 / 6.1 and asks you whether you want to install Security Manager in an HA/DR configuration. If you select this option, the only additional information to specify beyond a regular installation is the database password. In a non-HA/DR installation, the database password is autogenerated. However, since the database password must be the same on all servers in the HA/DR configuration, the installer prompts you to specify the password. You must use this same password on all servers in the HA/DR configuration.

The HA/DR installation installs the Cisco Security Manager agent for VCS, so VCS recognizes a new **CSManager** resource type and can control and monitor Security Manager.

The HA/DR installation also configures the Security Manager and related services in Windows for a Startup Type of Manual instead of Automatic, because the Veritas cluster server instead controls the starting and stopping of Security Manager on each server in the HA/DR configuration. Otherwise, the Security Manager application would try to start on all servers in the HA/DR configuration after any server reboot, when Security Manager should run only on one server at any time.

You must install Security Manager on each server in the HA/DR configuration. However, only the primary instance of Security Manager is used and protected in the HA/DR configuration. Other installations are performed to enable the primary instance to run on any of the secondary servers in the configuration.

This section contains the following topics:

- [Installing Security Manager on the Primary Server, page 3-7](#)
- [Installing Security Manager on Secondary Servers, page 3-9](#)

Installing Security Manager on the Primary Server

Use this procedure to install the primary instance of Security Manager that is used in production and is protected by the HA/DR configuration.

To install Security Manager on the primary server, follow these steps:

- Step 1** On the primary server in the cluster, open the Veritas Enterprise Administrator (VEA GUI) application and login.

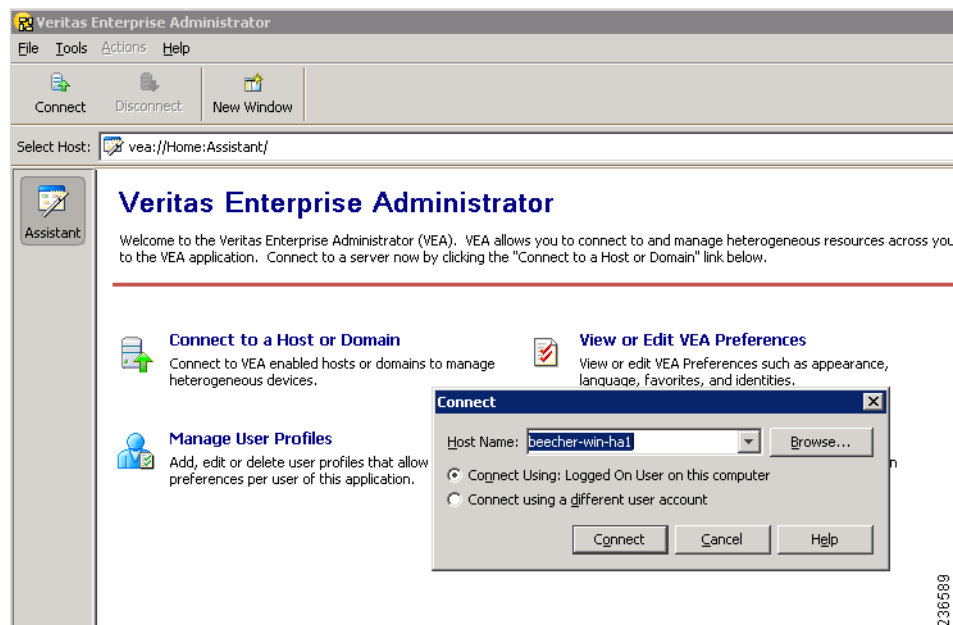

- Step 2** Right-click the **datadg** disk group and select **Import Dynamic Disk Group**.

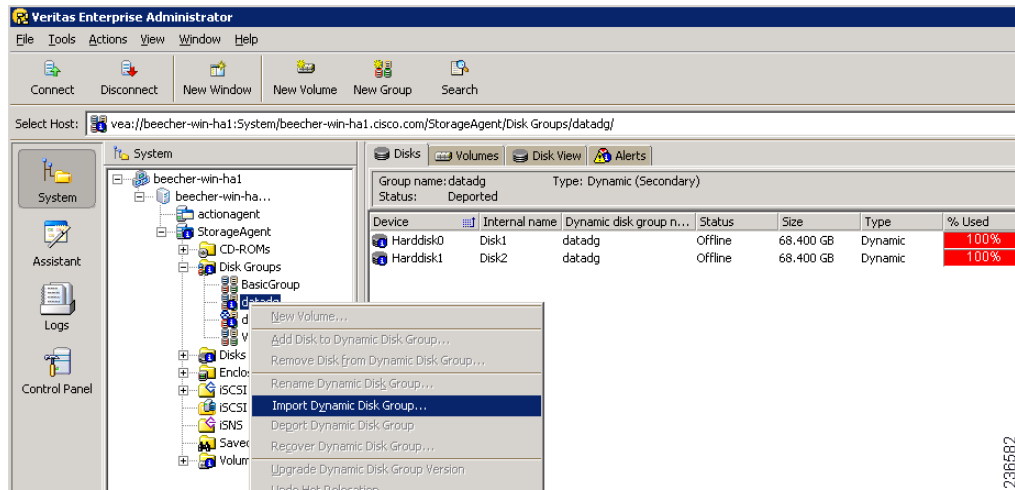

2386682

- Step 3** Make sure the **Import as dynamic disk group** option is selected, and then click **OK**.
- Step 4** Expand the **Volumes** folder under **System**.
- Step 5** Right-click the **cscopx** volume and choose **File System > Change Drive Letter and Path**.
- Step 6** Assign the desired drive letter to the **cscopx** volume and then click **OK**. Refer to the [Local Redundancy Configuration Worksheet, page 2-5](#), or [Geographic Redundancy \(DR\) Configuration Worksheet, page 2-7](#), for drive assignment.
- Step 7** Install Security Manager according to the Security Manager Installation Guide, while noting the following HA specific items.
- When prompted whether to install Security Manager for HA, indicate yes by checking the box.

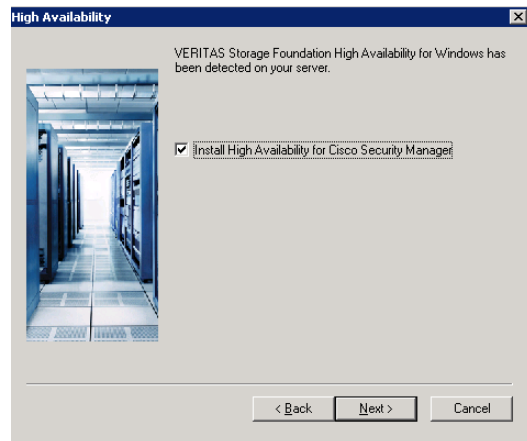

2386681

- When prompted for the installation directory, specify: `<Selected Drive Letter>:\Program Files\CSCOpX`.
- When prompted to specify the database password, choose an appropriate password and remember it; you will use this password for all Security Manager servers in the HA/DR configuration.



Note Near the end of the Security Manager installation, you might see a message that you are using a multihomed server and that you must update the `gatekeeper.cfg` file. You can ignore this message, because the agent scripts used in the HA/DR configurations modify this file.

- Step 8** After Security Manager has been installed, reboot the server.
- Step 9** After the system reboots, open the VEA GUI and check to see if the shared disk group is Imported. If the disk group status is Offline, repeat [Step 2](#) through [Step 6](#) to import the disk group and assign the same drive letter used during installation.
- Step 10** Start Security Manager using the `online.pl` script. For more information, see [Manually Starting, Stopping, or Failing Over Security Manager, page 4-3](#).



Note It is necessary to start Security Manager to complete configuration of the Windows registry entries needed for Security Manager to correctly operate.

- Step 11** Allow 5 to 10 minutes for Security Manager to complete startup, then log in to the application's web interface using the following URL: `http://<server hostname or IP address>:1741`. Verify that you can successfully log in.



Tip Alternatively, you can use the `pdshow` command to verify that the Cisco Security Manager services are running successfully.

- Step 12** Log out of the application's web interface, then stop Security Manager using the `offline.pl` script. For more information, see [Manually Starting, Stopping, or Failing Over Security Manager, page 4-3](#).

Installing Security Manager on Secondary Servers

Use this procedure to install Security Manager on secondary servers. Installing Security Manager on secondary servers is similar to installing it on a primary server, with one important difference. You install Security Manager onto a spare volume (`cscopx_spare`) associated with the specific secondary server, which is used again only if you want to upgrade or uninstall Security Manager. This spare volume must be large enough to hold the Security Manager application with an empty database (~2 GB). You can create the spare volume on the `datadg` disk group if enough space is available or, preferably, on a separate disk group.

To install Security Manager on a secondary server, follow these steps:

- Step 1** On the secondary server, open the Veritas Enterprise Administrator (VEA GUI) application and log in.

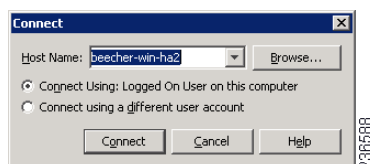

- Step 2** Right-click the `datadg_spare` disk group and select **Import Dynamic Disk Group**.

Step 3 Make sure the **Import as dynamic disk group** option is selected, and then click **OK**.

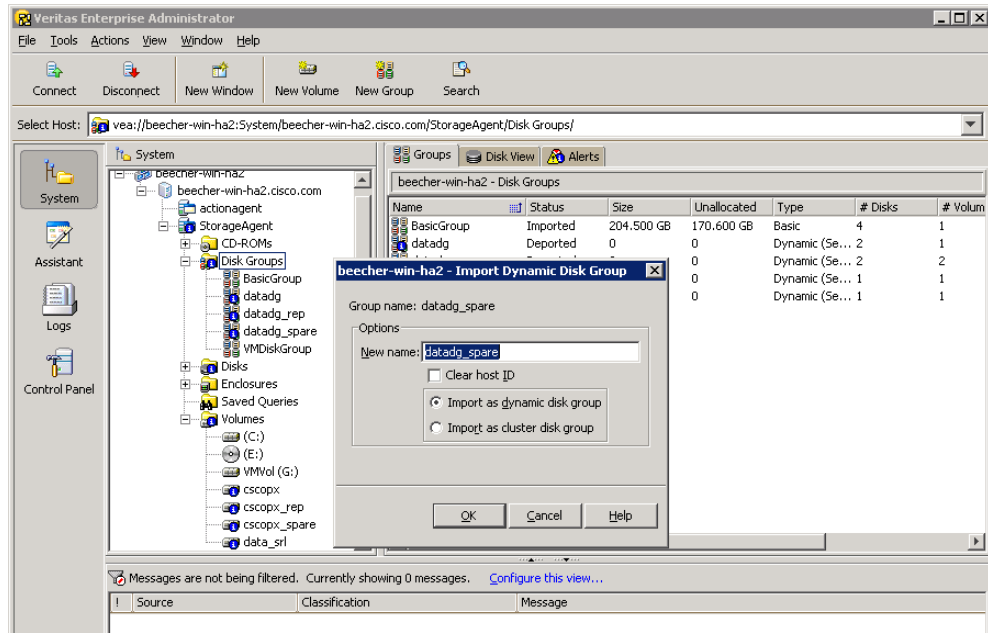

Step 4 Expand the **Volumes** folder under **System**.

Step 5 Right-click the **cscopx_spare** volume and choose **File System > Change Drive Letter and Path**.

Step 6 Assign the desired drive letter to the **cscopx_spare** volume and then click **OK**. Refer to the [Local Redundancy Configuration Worksheet, page 2-5](#), or [Geographic Redundancy \(DR\) Configuration Worksheet, page 2-7](#), for drive assignment.

Step 7 Install Security Manager according to the Security Manager Installation Guide, while noting the following HA-specific items.

- a. When prompted whether to install Security Manager for HA, indicate yes by checking the box.

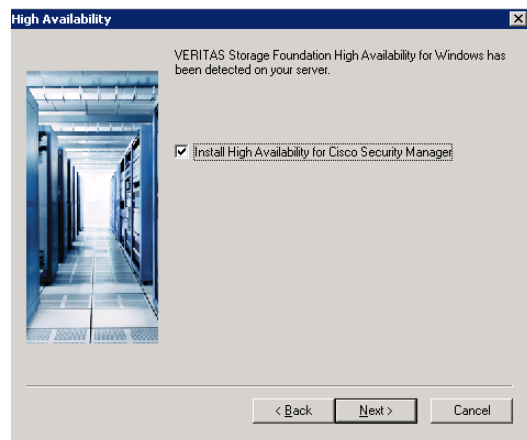

- b. When prompted for the installation directory, specify: `<Selected Drive Letter>:\Program Files\CSCOpX`.

- c. When prompted to specify the database password, choose the same password you chose for the primary server.



Note Near the end of the Security Manager installation, you might see a message that you are using a multihomed server and that you must update the gatekeeper.cfg file. You can ignore this message, because the online script used in the HA/DR configurations modifies this file.

- Step 8** After Security Manager has been installed, reboot the server.
- Step 9** After the system reboots, open the VEA GUI and check to see if the shared disk group is Imported. If the disk group status is Offline, repeat [Step 2](#) through [Step 6](#) to import the disk group and assign the same drive letter used during installation.
- Step 10** Start Security Manager using the online.pl script. For more information, see [Manually Starting, Stopping, or Failing Over Security Manager, page 4-3](#).



Note It is necessary to start Security Manager to complete configuration of the Windows registry entries needed for Security Manager to correctly operate.

- Step 11** Allow 5 to 10 minutes for Security Manager to complete startup, then log in to the application's web interface using the following URL: **http://<server hostname or IP address>:1741**. Verify that you can successfully log in.



Tip Alternatively, you can use the **pdshow** command to verify that the Cisco Security Manager services are running successfully.

- Step 12** Log out of the application's web interface, then stop Security Manager using the offline.pl script. For more information, see [Manually Starting, Stopping, or Failing Over Security Manager, page 4-3](#).
- Step 13** After installation is complete, unassign the drive letter from the spare volume.

Manually Starting Services in Secondary HA Server

If in Security Manager version 4.9, one or more services do not start up in secondary HA server in DR mode, follow these steps:

- Step 1** Run the following command to reset the casuser password:
- ```
<NMSROOT>\setup\support\resetcasuser.exe
```
- Example: C:\Progra-2\CSCOpX\setup\support\resetcasuser.exe
- Step 2** Of the two options displayed, on screen, choose option 2 -Enter casuser password. You will be prompted to enter a password for casuser and then to reenter the password for confirmation.
- Step 3** If local security policy is configured, add the casuser account to the 'Log on as a service' operation in the local security policy.



**Note** The following five permissions are assigned and set, automatically, at the time of Security Manager installation:  
Access this computer from network- casusers, Deny access to this computer from network-casuser, Deny logon locally-casuser, Log on as a batch job-casuser casusers, and Log on as a service- casuser.

**Step 4** Run the following command to apply the casuser permission to NMSROOT:

```
C:\Windows\System32\cacls.exe "<NMSROOT>" /E /T /G Administrators:F casusers:F
```

Example: C:\Windows\System32\cacls.exe "C:\Progra~2\CSCOpX" /E /T /G Administrators:F casusers:F

**Step 5** Run the following command to set the casuser to database services.

```
<NMSROOT>\bin\perl <NMSROOT>\bin\ChangeService2Casuser.pl casuser <casuserpassword>
```

Example: C:\Progra~2\CSCOpX\bin\perl C:\Progra~2\CSCOpX\bin\ChangeService2Casuser.pl casuser admin123

## Veritas Volume Replicator Tasks

Use this procedure to configure replication for a dual geographic cluster configuration where replication is running between the clusters.

To configure replication, follow these steps:

**Step 1** Using VEA GUI, connect to the primary and secondary hosts.

**Step 2** Make sure that the *datadg* disk group is imported on both the primary and secondary server.

**Step 3** Choose **View > Connection > Replication Network**.

**Step 4** Select **Replication Network** from the tree, select the **Setup Replicated Data Set** wizard from the toolbar, and then specify the following on the first panel of the wizard:

- Replicated Data Set Name: **CSM\_RDS**
- Replicated Volume Group name: **CSM\_RVG**
- Select the primary host from the drop-down list.

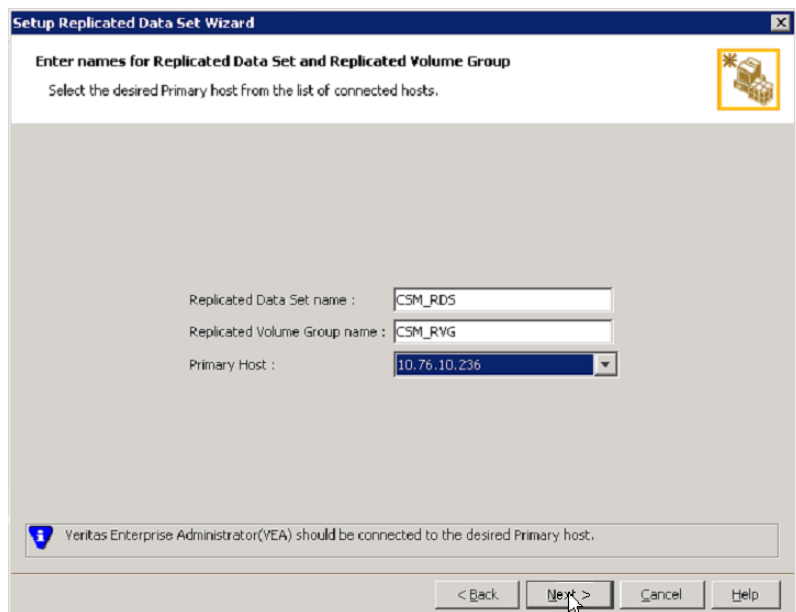

**Step 5** Click **Next**, and on the Select Dynamic Disk Group and volumes to be replicated panel of the wizard, specify the following:

- Dynamic Disk Group: **datadg**
  - Volumes: **cscopx**
- Step 6** Click **Next**. If data\_srl is the only other available volume, it will automatically be selected as the storage volume for the replicator log. If more than one additional volume is available, the Storage Replicator Log panel appears. Specify the following:
- Volume for the Replicator Log: **data\_srl**
- Step 7** Click **Next**, review the summary information, and then click **Create Primary RVG** to create the RVG.
- Step 8** After successfully creating the Primary RVG, click **Yes** when prompted to add a secondary host to the RDS.
- Step 9** On the Specify Secondary host for replication panel, enter the name or IP address of the secondary host in the Secondary Host field.

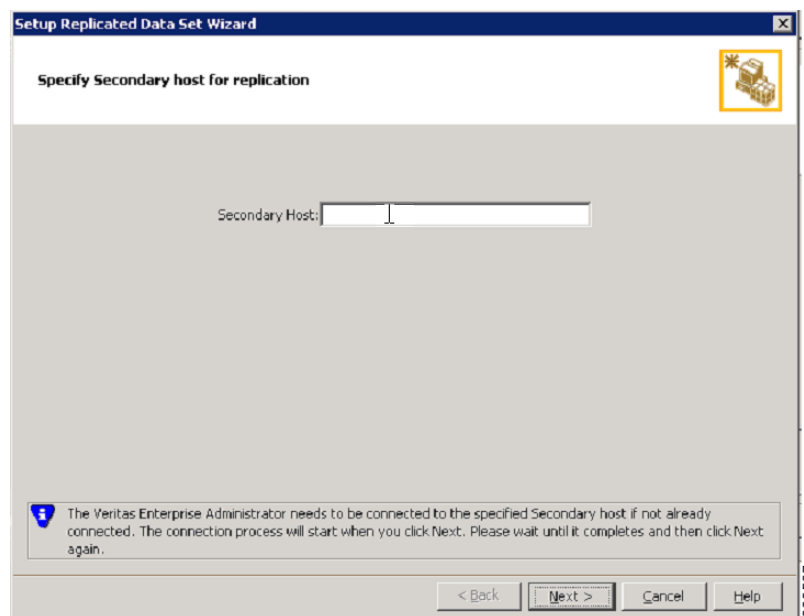

- Step 10** Click **Next** and on the edit replication settings panel specify the following:



**Note**

For the primary and secondary side IP addresses you can specify the fixed IP addresses of the NIC cards. However, if you use Veritas Cluster Server, you must go back later and update the IP address to use virtual IP addresses under VCS control. Do this from VEA by selecting the secondary RVG in the tree and then choosing **Actions > Change Replication Settings**.

- Primary side IP: <IP address of the primary server>
- Secondary side IP: <IP address of the secondary server>
- Replication Mode: **Synchronous Override**
- Replicator Log Protection: <Choose from **Off**, **Fail**, **DCM**, **AutoDCM** (Default), **Override**>. See the Volume Replicator administrator's guide for descriptions of each choice.

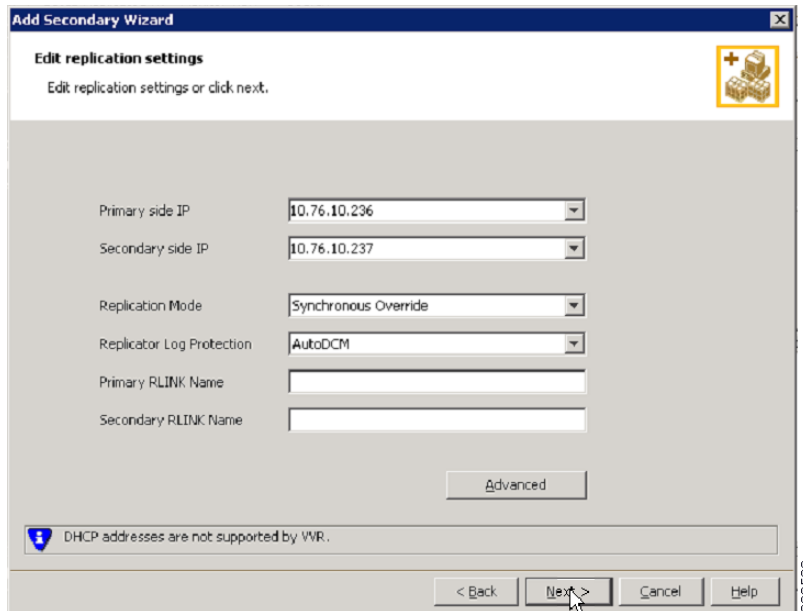

**Step 11** Click **Next** to start replication with the default settings. Select **Synchronize Automatically** and make sure **Start Replication** is checked.

**Step 12** Click **Next** to display the Summary page, and then click **Finish**.

## Updating Permissions on the Working Volume

When Security Manager is installed, it creates a special local user (casuser) and group (casusers) for running Security Manager. To run the protected instance of Security Manager on secondary servers, you must add the local casusers group permissions to the cscopx volume.

This section contains the following topics:

- [Updating Permissions when using Shared Storage, page 3-14](#)
- [Updating Permissions when using Replication, page 3-15](#)

### Updating Permissions when using Shared Storage

To add the local casusers group permissions for a secondary server when using shared storage, follow these steps:

- 
- Step 1** If it is running on the primary server, stop Security Manager using the offline.pl script. For more information, see [Manually Starting, Stopping, or Failing Over Security Manager, page 4-3](#).
- Step 2** Deport the **datadg** disk group from the primary server.
- Step 3** Import the **datadg** diskgroup onto the secondary server.
- Step 4** Assign the primary volume (cscopx) to the selected drive letter using either the VEA GUI or the command line.

- Step 5** From Windows Explorer, right-click the <Selected Drive Letter>\Program Files\CSCOpX folder and choose the **Sharing and Security** menu item.
- Step 6** The folder properties dialog box appears. Select the **Security** tab, and then click **Add**.
- Step 7** In the Select Users or Groups dialog box, click **Location**, and then select the local server from the selection tree.
- Step 8** Enter **casusers** in the enter object names text box, and then click **Check Names**. The text box should then display <ServerName>\casusers. Click **OK**.
- Step 9** Making sure casusers is selected, check the **Full Control** check box under Allow to grant the casusers group full control.
- Step 10** Click **Advanced**.
- Step 11** Under Advanced Settings, check the **Replace permission entries on all child objects with entries shown here that apply to child objects** check box.
- Step 12** Click **Apply** and wait for the permissions to propagate to all child objects under the CSCOpX directory.
- Step 13** When propagation is complete, click **OK**.
- Step 14** Click **OK** to close the CSCOpX Properties dialog box.
- Step 15** Unassign the drive letter from the cscopx volume.
- Step 16** Deport the datadg disk group from the secondary server.
- Step 17** Import the datadg diskgroup onto the primary server.
- Step 18** Assign the primary volume (cscopx) to the selected drive letter using either the VEA GUI or the command line.
- 

## Updating Permissions when using Replication

To add the local casusers group permissions for a secondary server when using replication, follow these steps:

- Step 1** If it is running on the primary server, stop Security Manager using the offline.pl script. For more information, see [Manually Starting, Stopping, or Failing Over Security Manager, page 4-3](#).
- Step 2** Unassign the drive letter from the cscopx volume.
- Step 3** Migrate the replication primary to the secondary.
- Step 4** Assign the selected drive letter to the cscopx volume on the secondary server.
- Step 5** From Windows Explorer, right-click the <Selected Drive Letter>\Program Files\CSCOpX folder and choose the **Sharing and Security** menu item.
- Step 6** The folder properties dialog box appears. Select the **Security** tab and click **Add**.
- Step 7** In the Select Users or Groups dialog box click **Location**, and select the local server from the selection tree.
- Step 8** Enter **casusers** in the enter object names text box, and then click **Check Names**. The text box should then display <ServerName>\casusers. Click **OK**.
- Step 9** Making sure casusers is selected, check the **Full Control** check box under Allow to grant the casusers group full control.

- Step 10** Click **Advanced**.
- Step 11** Under the Advanced Settings, check the **Replace permission entries on all child objects with entries shown here that apply to child objects** check box.
- Step 12** Click **Apply** and wait for the permissions to be propagated to all child objects under the CSCOpX directory.
- Step 13** When propagation is complete, click **OK**.

**Note**

While the permissions are being updated you may encounter an error dialog with the title “Error Applying Security” with the message “An error occurred applying security information to: <Selected Drive Letter>:\Program Files\CSCOpX\log\dcr.log. Access is denied.” You can safely ignore this error and click **Continue** on the error dialog to complete the process of updating permissions.

- Step 14** Click **OK** to close the CSCOpX Properties dialog box.
- Step 15** Unassign the drive letter from the cscopx volume.
- Step 16** Migrate the replication back to the primary server.
- Step 17** Assign the selected drive letter to the cscopx volume on the primary server.

## Veritas Cluster Server Tasks

This section describes the process for setting up and configuring the Veritas cluster(s). There are two specific scenarios described:

[Single Local Cluster \(Dual-Node\) Configuration, page 3-16](#)

[Dual Geographic Cluster Configuration, page 3-24](#)

## Single Local Cluster (Dual-Node) Configuration

This section covers the setup and configuration of a single, local cluster with two nodes in the cluster (primary and secondary).

This section contains the following topics:

- [Creating the Cluster, page 3-16](#)
- [Creating the Application Service Group, page 3-17](#)
- [Creating the ClusterService Group \(Optional\), page 3-23](#)

## Creating the Cluster

To create the cluster, follow these steps:

- Step 1** Create a cluster using the VCS Cluster Configuration wizard, where:
- Cluster Name = CSManager\_Primary
  - Cluster ID = 0



Include the primary and secondary servers in the definition of the cluster. Part of the cluster definition in the wizard is to specify the NICs for the private network. VCS uses a private network for communications between cluster nodes for cluster maintenance. You can also assign one of the network Ethernet interfaces to act as low-priority cluster communications interface in case all the dedicated cluster communication interfaces fail.

- Step 2** To start the Cluster Manager, choose **Start > All Programs > Symantec > Veritas Cluster Server > Veritas Cluster Manager - Java Console** and log in to the cluster.
- Step 3** Using the Cluster Manager, import the **CSManager** resource type by choosing **File > Import Types**. Browse to the **CSManagerTypes.cf** file located under **\$VCS\_ROOT\cluster server\conf\config** and click **Import**.

## Creating the Application Service Group

To create the application service group, follow these steps:

- Step 1** Right-click the **CSManager** resource and select **Add Service Group**.

Add a service group called **APP**, and include both servers for this service group with the Startup option checked for each server and the service group type of Failover.

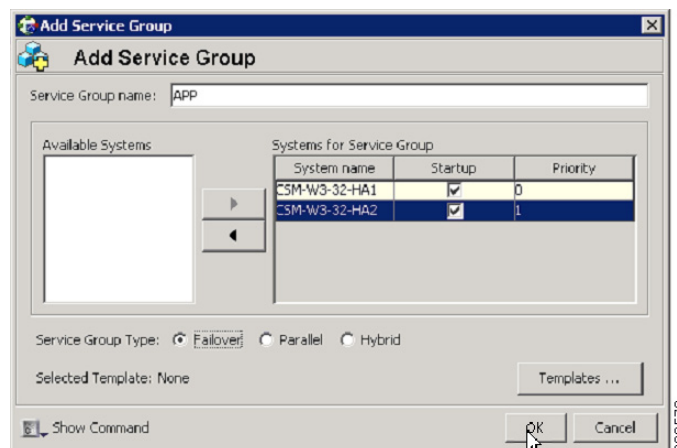

- Step 2** Right-click the **APP** service group and select **Add Resource**.

Add the NIC resource and check the **Critical** and **Enabled** check boxes.

- Resource name = **NIC**
- Resource Type = **NIC**
- MACAddress = <MAC address of the NIC used for accessing the Security Manager application>, which is defined uniquely for each server in the cluster.



### Note

You can find the MAC address associated with each Ethernet interface using the DOS-level command **ipconfig -all**.

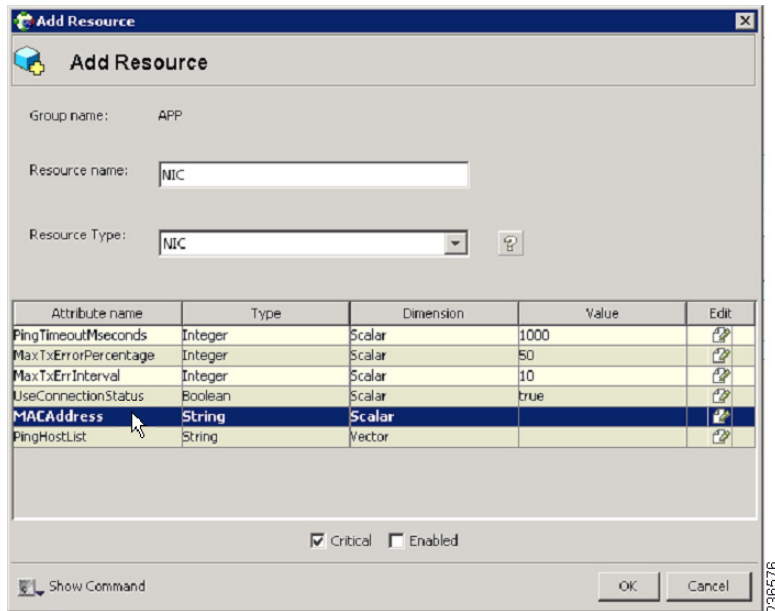

**Step 3** Right-click the **APP** service group and select **Add Resource**.

Add the IP resource and check the **Critical** and **Enabled** check boxes.

- Resource name = **APP\_IP**
- Resource Type = **IP**
- Address = <Virtual IP address allocated for use by the Security Manager application> (defined as a Global attribute)
- SubNetMask = <subnet mask> (defined as a Global attribute)
- MACAddress = <MAC Address of the NIC used for accessing the Security Manager application>, (defined for each server in the cluster)

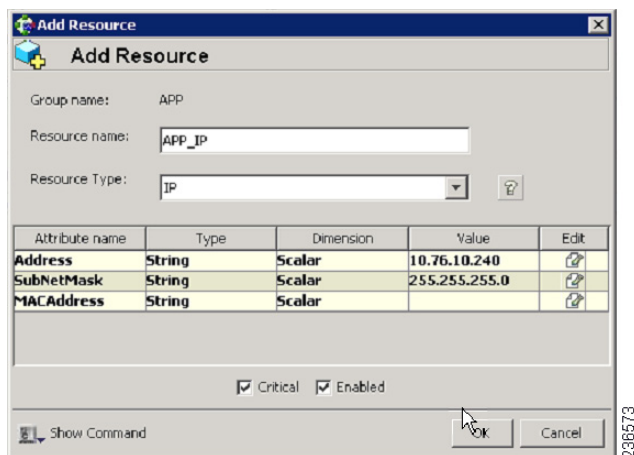

- Step 4** Right-click the **APP** service group and select **Add Resource**.  
Add the **VMDg** Resource and check the **Critical** and **Enabled** check boxes.
- Resource name = **datadg**
  - Resource Type = **VMDg**
  - DiskGroupName = **datadg**  
(defined as a Global attribute)

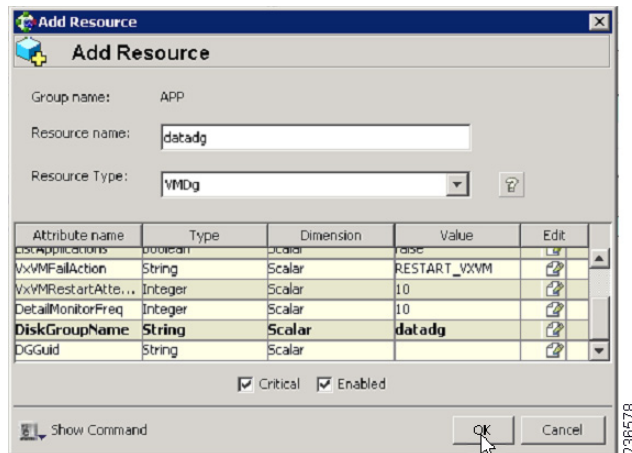

- Step 5** Right-click the **VMDg** resource group and select **Add Resource**.  
Add the **datadg\_evt** resource and check the **Critical** and **Enabled** check boxes.
- Resource name = **datadg\_evt**
  - Resource Type = **VMDg**
  - DiskGroupName = **datadg\_evt**  
(defined as a Global attribute)

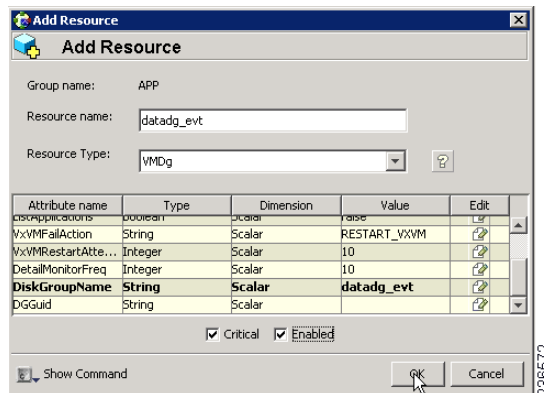

- Step 6** Right-click the **APP** service group and select **Add Resource**.  
Add the **MountV** Resource and check the **Critical** and **Enabled** check boxes.
- Resource name = **APP\_MountV**
  - Resource Type = **MountV**

- MountPath = <Selected Drive Letter>:\  
(defined as a Global attribute)
- VolumeName = **cscopx**  
(defined as a Global attribute)
- VMDGResName = **datadg**  
(defined as a Global attribute)
- ForceUnmount = {NONE, READ-ONLY, ALL}

Defines whether the agent unmounts the volume forcibly when it is being used by other applications. The following choices are available:

- NONE: The agent does not unmount the volume if an application is accessing it.
- READ-ONLY: The agent unmounts the volume if applications are accessing it in a read-only mode.
- ALL: The agent unmounts the volume regardless of the type of access an application has.

The default is NONE. If the volume cannot be unmounted, automatic failover to the secondary server might be prevented, so you might want to select a value of READ-ONLY or ALL.

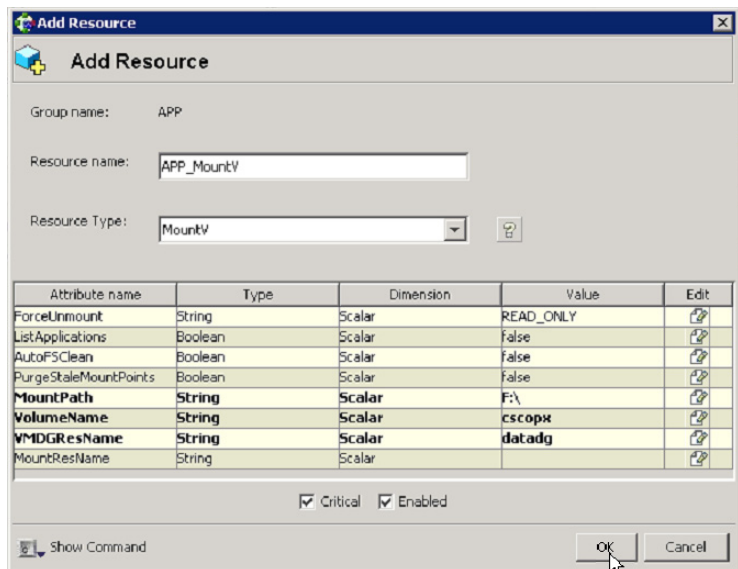

**Step 7** Right-click the **MountV** resource group and select **Add Resource**.

Add the MountV\_evt Resource and check the **Critical** and **Enabled** check boxes.

- Resource name = **APP\_MountV\_evt**
- Resource Type = **MountV**
- MountPath = <Selected Drive Letter>:\  
(defined as a Global attribute)
- VolumeName = **cscopx\_evt**  
(defined as a Global attribute)
- VMDGResName = **datadg\_evt**  
(defined as a Global attribute)
- ForceUnmount = {NONE, READ-ONLY, ALL}

Defines whether the agent unmounts the volume forcibly when it is being used by other applications. The following choices are available:

- NONE: The agent does not unmount the volume if an application is accessing it.
- READ-ONLY: The agent unmounts the volume if applications are accessing it in a read-only mode.
- ALL: The agent unmounts the volume regardless of the type of access an application has.

The default is NONE. If the volume cannot be unmounted, automatic failover to the secondary server might be prevented, so you might want to select a value of READ-ONLY or ALL.

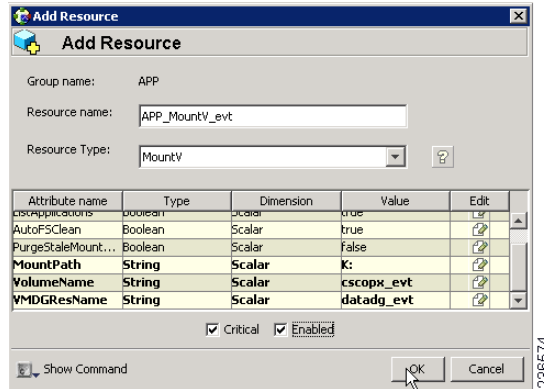

**Step 8** Right-click the **APP** service group and select **Add Resource**.  
Add the **RegRep** resource and check the **Critical** and **Enabled** check boxes.

- Resource name = **APP\_RegRep**
- Resource Type = **RegRep**
- MountResName = **APP\_MountV**  
(defined as a Global attribute)
- ReplicationDirectory = **\REGREP\DEFAULT**  
(defined as a Global attribute)
- Keys (defined as a Global attribute)  
Key = **HKLM\Software\JavaSoft\Prefs\vms**  
Value = <blank>

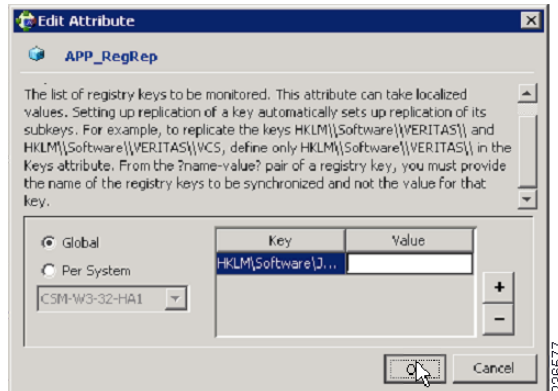

**Note**

Security Manager stores client user preferences in the server registry under HKEY\_LOCAL\_MACHINE\SOFTWARE\JavaSoft\Prefs\vms. The registry replication agent (RegRep) monitors changes to the specified registry location on the active server and synchronizes these changes to a secondary server in the event of a failover.

**Step 9** Right-click the **APP** service group and select **Add Resource**.

Add the CSManager resource and check the **Critical** and **Enabled** check boxes.

- Resource name = **APP\_CSManager**
- Resource Type = **CSManager**
- PathName = <Selected Drive Letter>:\Program Files\CSCOpX\  
(defined as a Global attribute)
- EventIPAddress = The same IP address as used in APP\_IP  
(defined as a Global attribute)
- CertificateDir = See [Security Certificates for SSL, page 4-2](#), for an explanation of this attribute.

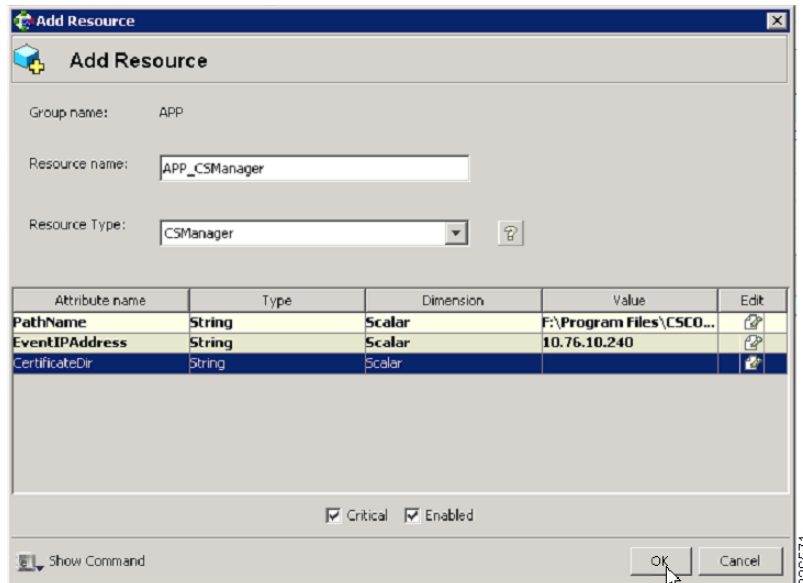

**Step 10** Link the resources as defined in the following table (see [Figure A-1 on page A-2](#)).

| Parent Resource | Child Resource |
|-----------------|----------------|
| APP_CSManager   | APP_RegRep     |
| APP_CSManager   | APP_IP         |
| APP_IP          | NIC            |
| APP_RegRep      | APP_MountV     |
| APP_RegRep      | APP_MountV_evt |
| APP_MountV      | datadg         |
| APP_MountV_evt  | datadg_evt     |

To link resources, follow these steps:

- a. Right-click the parent resource, and then select **Link**.

The Link Resources dialog box appears.

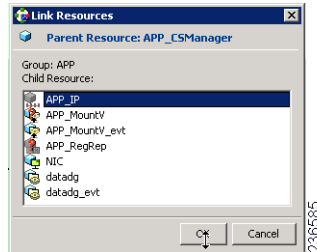

- b. Select the child resource, and then click **OK**.

The selected resources are linked.

When all links have been made, your resource view should look like the following:

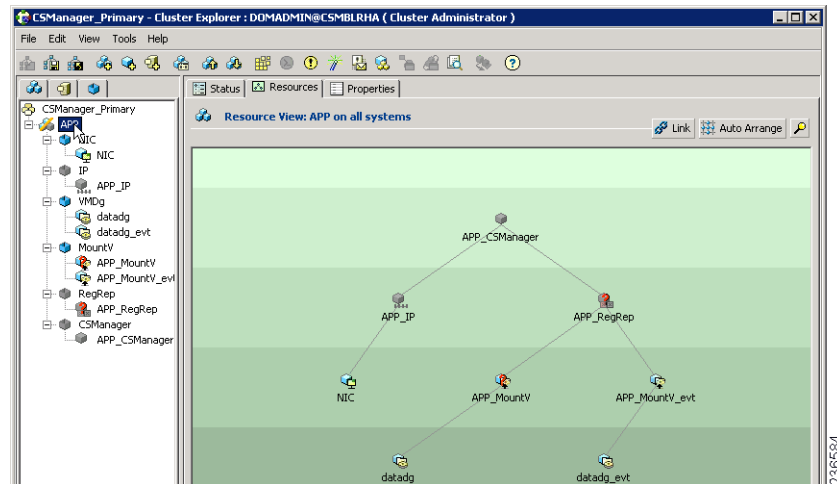

## Creating the ClusterService Group (Optional)

You can optionally configure a ClusterService group to run the following optional components:

- Cluster Manager (Web Console)
- Notification

You can use the VCS Configuration wizard to configure these components. See the Veritas Cluster Server administrator's guide for details. The notification service is useful because it can notify you of events happening in the cluster either through email or SNMP traps.

## Dual Geographic Cluster Configuration

This section covers the setup and configuration of two clusters geographically separated with a single node in each cluster.



### Note

You can also create dual geographic cluster configurations with multiple nodes within one or both clusters.

This section contains the following topics:

- [Creating the Primary and Secondary Clusters, page 3-24](#)
- [Creating the ClusterService Group, page 3-25](#)
- [Creating the Replication Service Group, page 3-26](#)
- [Creating the Application Service Group, page 3-27](#)
- [Creating the Cluster Level Configuration, page 3-29](#)

## Creating the Primary and Secondary Clusters

To create the primary and secondary clusters, follow these steps:

- 
- Step 1** Create a cluster on the primary server (in the primary cluster) using the VCS Cluster Configuration wizard, where:
- Cluster Name = CSManager\_Primary
  - Cluster ID = 0
- Step 2** Create a cluster on the primary server (in the secondary cluster) using the VCS Configuration wizard, where:
- Cluster Name = CSManager\_Secondary
  - Cluster ID = 1
- Step 3** In the primary cluster, start the Cluster Manager by choosing **Start > All Programs > Symantec > Veritas Cluster Server > Veritas Cluster Manager - Java Console** and log in to the cluster.
- Step 4** Using the Cluster Manager, import the **CSManager** resource type by choosing **File > Import Types**. Browse to the CSManagerTypes.cf file located under \$VCS\_ROOT\cluster server\conf\config and click **Import**.
- Step 5** Repeat Steps 3 and 4 for the secondary cluster.
-



## Creating the ClusterService Group

To create the ClusterService group, follow these steps:



### Note

Perform these steps on both the primary and secondary clusters.



### Tip

You can use the VCS Configuration wizard as an alternate method to the procedures in this section for creating the ClusterService group and wac resource for intercluster communications. You can also configure the optional Cluster Manager (Web Console) and Notification components with the VCS Configuration wizard. See the Veritas Cluster Server administrator's guide.

**Step 1** Right-click the **CSManager** resource and select **Add Service Group**.

Add a service group called **ClusterService**.

**Step 2** Right-click the **ClusterService** service group and select **Add Resource**.

Add the NIC resource:

- Resource name = **NIC**
- Resource Type = **NIC**
- MACAddress = <MAC Address of the NIC card>



### Note

You can find the MAC address associated with each Ethernet interface using the DOS-level command **ipconfig -all**.

**Step 3** Right-click the **ClusterService** service group and select **Add Resource**.

Add the IP resource

- Resource name = **VCS\_IP**
- Resource Type = **IP**
- Address = <Virtual IP address allocated for the cluster>
- SubNetMask = <subnet mask>
- MACAddress = <MAC Address of the corresponding NIC card>

**Step 4** Right-click the **ClusterService** service group and select **Add Resource**.

Add the wac resource:

- Resource name = **wac**
- Resource Type = **Process**
- StartProgram = **C:\Program Files\Veritas\Cluster Server\bin\wac.exe**
- StopProgram = **C:\Program Files\Veritas\Cluster Server\bin\wacstop.exe**
- MonitorProgram = **C:\Program Files\Veritas\Cluster Server\bin\wacmonitor.exe**

**Step 5** Link the resources as defined in the following table (see [Figure A-4 on page A-4](#)).

| Parent Resource | Child Resource |
|-----------------|----------------|
| wac             | VCS_IP         |
| VCS_IP          | NIC            |

To link resources, follow these steps:

- a. Right-click the parent resource, and then select **Link**.  
The Link Resources dialog box appears.
- b. Select the child resource, and then click **OK**.  
The selected resources are linked.

## Creating the Replication Service Group

To create the replication service group, follow these steps:



### Note

Perform these steps on both the primary and secondary clusters.

**Step 1** Right-click the **CSManager** resource and select **Add Service Group**.

Add a service group called APPrep.

**Step 2** Right-click the **APPrep** service group and select **Add Resource**.

Add the Proxy resource:

- Resource name = **VVR\_NIC\_Proxy**
- Resource Type = **Proxy**
- TargetResName = **NIC**

**Step 3** Right-click the **APPrep** service group and select **Add Resource**.

Add the IP resource:

- Resource name = **VVR\_IP**
- Resource Type = **IP**
- Address = <Virtual IP address allocated for replication>
- SubNetMask = <subnet mask>
- MACAddress = <MAC address of the corresponding NIC card>

**Step 4** Right-click the **APPrep** service group and select **Add Resource**.

Add the VMDg resource:

- Resource name = **datadg**
- Resource Type = **VMDg**
- DiskGroupName = **datadg**

**Step 5** Right-click the **APPprep** service group and select **Add Resource**.

Add the VvrRvg resource:

- Resource name = **APP\_RVG**
- Resource Type = **VvrRvg**
- RVG = **CSM\_RVG**
- VMDGResName = **datadg**
- IPResName = **VVR\_IP**

**Step 6** Link the resources as defined in the following table (see [Figure A-3 on page A-3](#)).

| Parent Resource | Child Resource |
|-----------------|----------------|
| VVR_IP          | VVR_NIC_Proxy  |
| APP_RVG         | VVR_IP         |
| APP_RVG         | datadg         |

To link resources, follow these steps:

- a. Right-click the parent resource, and then select **Link**.  
The Link Resources dialog box appears.
- b. Select the child resource, and then click **OK**.  
The selected resources are linked.

## Creating the Application Service Group

To create the application service group, follow these steps:



**Note** Perform these steps on both the primary and secondary clusters.

**Step 1** Add a service group called APP.

**Step 2** Right-click the **APP** service group and select **Add Resource**.

Add the RVG primary resource:

- Resource name = **APP\_RVGPrimary**
- Resource Type = **RVGPrimary**
- RvgResourceName = **APP\_RVG**

**Step 3** Right-click the **APP** service group and select **Add Resource**.

Add the MountV resource:

- Resource name = **APP\_MountV**
- Resource Type = **MountV**
- Mount Path = <Selected Drive Letter>:\

- Volume Name = **cscopx**
- VMDg Resource Name = **datadg**

**Step 4** Right-click the **APP** service group and select **Add Resource**.

Add the RegRep resource and check the **Critical** and **Enabled** check boxes.

- Resource name = **APP\_RegRep**
- MountResName = **APP\_MountV**
- ReplicationDirectory = **\REGREP\DEFAULT**
- Keys = **HKLM\Software\JavaSoft\Prefs\vms**



**Note**

Security Manager stores client user preferences in the server registry under HKEY\_LOCAL\_MACHINE\SOFTWARE\JavaSoft\Prefs\vms. The registry replication agent (RegRep) monitors changes to the specified registry location on the active server and synchronizes these changes to a secondary server in the event of a failover.

**Step 5** Right-click the **APP** service group and select **Add Resource**.

Add the Proxy resource:

- Resource name = **APP\_NIC\_Proxy**
- Resource Type = **Proxy**
- TargetResName = **NIC**

**Step 6** Right-click the **APP** service group and select **Add Resource**.

Add the IP resource:

- Resource name = **APP\_IP**
- Resource Type = **IP**
- Address = <Virtual IP address allocated for the application>
- SubNetMask = <subnet mask>
- MACAddress = <MAC address of the corresponding NIC card>

**Step 7** Right-click the **APP** service group and select **Add Resource**.

Add the CSManager resource:

- Resource name = **APP\_CSManager**
- Resource Type = **CSManager**
- PathName = <Selected Drive Letter>:\Program Files\CSCOpX
- EventIPAddress = The same IP address as you used in APP\_IP
- CertificateDir = See [Security Certificates for SSL, page 4-2](#), for an explanation of this attribute.

**Step 8** Link the resources as defined in the following table (see [Figure A-2 on page A-3](#)).

| Parent Resource | Child Resource |
|-----------------|----------------|
| APP_MountV      | APP_RVGPrimary |
| APP_RegRep      | APP_MountV     |
| APP_CSManager   | APP_RegRep     |

| Parent Resource | Child Resource |
|-----------------|----------------|
| APP_IP          | APP_NIC_Proxy  |
| APP_CSManager   | APP_IP         |

To link resources, follow these steps:

- a. Right-click the parent resource, and then select **Link**.  
The Link Resources dialog box appears.
- b. Select the child resource, and then click **OK**.  
The selected resources are linked.

## Creating the Cluster Level Configuration

To create the cluster level configuration, follow these steps:

- Step 1** Link the APP service group as the parent of the APPrep service group with an online local firm dependency. Perform this step on both the primary and secondary clusters.
- Step 2** Under the cluster properties specify the cluster address, which is the same IP address that you used in the VCS\_IP resource.
- Step 3** From the primary cluster, choose **Edit > Add/Delete Remote Cluster** to use the Remote Cluster Configuration wizard to add the secondary cluster.
- Step 4** From the primary cluster, choose **Edit > Configure Global Groups** to use the Global Group Configuration wizard to configure the APP service group as a global group.  
See [Figure A-5 on page A-4](#).





## Maintenance Activities

---

This chapter describes maintenance activities related to Security Manager when it is used in an HA/DR configuration. This chapter contains the following topics:

- [Customizing VCS Behavior, page 4-1](#)
- [Security Certificates for SSL, page 4-2](#)
- [Manually Starting, Stopping, or Failing Over Security Manager, page 4-3](#)
- [Integrating Cisco Secure ACS with Security Manager, page 4-5](#)
- [Upgrading Security Manager, page 4-6](#)
- [Backing Up Security Manager, page 4-6](#)
- [Uninstalling Security Manager, page 4-6](#)
- [Migrating a Non-HA Security Manager to HA, page 4-8](#)

## Customizing VCS Behavior

VCS supports an extensive number of variables to control VCS behavior, such as responses to resource failures. If you followed the default installation as described in this document, here are some of the resulting failover behaviors. You should review these and other behavior controls as described in *Veritas Cluster Server User's Guide*.

- If Security Manager fails, VCS does not try to restart the application on the same server; instead, VCS fails it over to the standby server in the cluster. However, you can use a resource-level attribute, `RestartLimit`, to control the number of times the agent tries to restart the resource before declaring the resource as faulted.
- When first trying to bring the Security Manager application online on a given server, VCS will attempt to bring the resource online only once. The `OnlineRetryLimit` resource-level attribute specifies the number of times the online entry point is retried if the initial attempt fails.
- By default, VCS runs the Security Manager application monitor script every 60 seconds. This means that it can take up to 60 seconds to detect an application failure. The `MonitorInterval` is a resource-level attribute that can be adjusted.
- If you are using dual clusters, failover between the clusters is a manual operation by default. This avoids having both clusters running the application simultaneously. If communication between the clusters is lost (which can readily happen if no redundant paths exist between geographically separated data centers), VCS cannot determine whether the remote cluster failed or a communication problem exists. If you prefer automatic failover between clusters, you can configure it with the `ClusterFailOverPolicy` attribute on the APP service group.

# Security Certificates for SSL

Security Manager allows configuring the use of Secure Socket Layer (SSL) encryption between the server and the client browser or application. SSL encryption requires the creation and placement of a digital certificate on the server. Part of the identity information contained in the digital certificate is the Common Name (CN) or “Host Name” as shown on the Common Services web GUI. In a HA/DR configuration where there are multiple servers and corresponding hostnames you may want to take special steps to ensure that you maintain a certificate that matches the hostname or IP address used to access the application.

In the case of a single cluster, you access the application with a single virtual IP address or virtual hostname. In this case you should create a certificate with the CN equal to the virtual IP address or virtual hostname. Because the virtual IP or virtual hostname address is valid regardless of the server in the cluster running the application, you do not need to update the digital certificate files in the event of a failover.

However, in the case of a dual geographic cluster configuration, each cluster has its own IP address or hostname associated with the application. As a result, if the digital certificate file has been created to match one cluster, it will not match when the application fails over to the other cluster. In this case you might want to update the digital certificate files to match the other cluster in the event of an inter-cluster failover.



## Note

If you use a virtual hostname to access the application, you can avoid having to update the certificates for an inter-cluster failover by instead using DNS updating. In the event of an inter-cluster failover, DNS is updated with the new IP address associated with the virtual hostname. Because clients are using the same virtual hostname in all cases to access the application, there is no need to update the certificate files.

The Security Manager Agent for VCS can automatically copy digital certificate files stored on a non-shared, non-replicated local directory prior to starting the application. However, you need to place the appropriate files in this directory on each server in the clusters. The directory is specified to the agent using the CertificateDir parameter.

In the case of a geographic redundancy (DR) configuration where there is a single server at each site, a simpler option is available. You can configure the agent to regenerate the certificate files based on the hostname of the server. This works because there are no virtual IP addresses or virtual hostnames involved. To configure the agent for this behavior, specify the keyword **regen** for the value of the CertificateDir parameter.

When Security Manager is installed, it creates by default a self-signed certificate matching the local hostname of the server. If appropriate for your configuration, to generate a self-signed certificate matching a virtual IP address or virtual hostname, follow this procedure:

- 
- Step 1** Log in to the web browser interface of the server (<http://<hostname or IP address>:1741>).
  - Step 2** Access the self-signed Certificate Setup screen as follows:
    - a. On the Cisco Security Management Suite homepage, click **Server Administration**.
    - b. From the menu on the Server Admin page, select **Server > Single Server Management > Certificate Setup**.
  - Step 3** Populate the fields of the certificate and specify either the virtual IP address or virtual hostname in the CN field, then click **Apply**.



The following certificate-related files are generated in the NMSROOT\MDC\Apache\conf\ssl directory:

- server.key
- server.crt
- server.pk8
- server.csr
- openssl.conf
- chain.cer

If you are using a single cluster, no further action is required. However, if you are using a dual geographic cluster configuration with multiple servers in each cluster, you should copy the certificate-related files listed above to a non-shared, non-replicated local directory on each server in the cluster. You should then do the same procedure for the secondary cluster, except this time specify the virtual IP address or virtual hostname of the secondary cluster. When you define the CSManager resource, specify the selected non-shared, non-replicated local directory for the **CertificateDir** attribute. The agent then automatically copies the certificate files to the appropriate working directory after a failover, prior to starting the application.

## Manually Starting, Stopping, or Failing Over Security Manager

In a non-HA/DR configuration, you normally start and stop Security Manager with the Windows Services application or its command-line equivalents, **net start** and **net stop**. However, in an HA/DR configuration, you must not use this approach. Specific scripts are provided for starting and stopping Security Manager in an HA/DR configuration. These scripts perform additional procedures necessary if you start Security Manager on a different server. These scripts and others make up the Security Manager agent for VCS. The agent enables VCS to control and monitor Security Manager. If you are not using VCS, you can use these scripts to manually start and stop Security Manager.

The section contains the following topics:

- [VCS Case, page 4-3](#)
- [Non-VCS Case, page 4-4](#)

### VCS Case

If you are using VCS, you should use the VCS controls to manually start, stop, or fail over the Security Manager service group (APP). In VCS terminology, start and stop are referred to as online and offline, respectively. You can bring online, bring offline, or fail over the Security Manager service group using the VCS GUI or the VCS command-line interface. Appendix B, [High Availability and Disaster Recovery Certification Test Plan, page B-1](#), has examples for performing such operations.



#### Caution

If you manually stop Security Manager outside of VCS (such as by using **net stop**), VCS views this as an application failure and tries to initiate recovery.

## Non-VCS Case

If you are not using VCS, you can use the **online** and **offline** scripts provided with Security Manager to start and stop Security Manager. These scripts can be found at:

\$NMSROOT\MDC\athena\ha\agent\Veritas60 (for Veritas 6.0.1)

\$NMSROOT\MDC\athena\ha\agent\Veritas602 (for Veritas 6.0.2)

\$NMSROOT\MDC\athena\ha\agent\Veritas61 (for Veritas 6.1)

---

Windows Server 2012, 2012R2 Syntax for Veritas 6.0.1, Veritas 6.0.2 and Veritas 6.1:

```
perl online.pl CSManager <PathName> <EventIPAddress> [<CertificateDir>|regen]
```

For example:

```
perl online.pl CSManager F:\Progra~1\CSCOpX 192.0.2.1
```

**Note** You must select the Run as administrator option when opening the Command Prompt.

---

| Syntax           | Description                                                                                                                                                                                                                                                                                                                                                                                                                                                                                                                                                                                                                            |
|------------------|----------------------------------------------------------------------------------------------------------------------------------------------------------------------------------------------------------------------------------------------------------------------------------------------------------------------------------------------------------------------------------------------------------------------------------------------------------------------------------------------------------------------------------------------------------------------------------------------------------------------------------------|
| <PathName>       | The Security Manager installation path (for example, “F:\Program Files\CSCOpX”). If the installation path contains spaces, enclose the argument in quotes.                                                                                                                                                                                                                                                                                                                                                                                                                                                                             |
| <EventIPAddress> | The IP address that the Security Manager application uses for client/server and server/device communications.                                                                                                                                                                                                                                                                                                                                                                                                                                                                                                                          |
| <CertificateDir> | Optional. Allows you to specify a nonshared, non-replicated local directory where SSL certificate files are kept. If specified, the script copies these files to the appropriate directory under the installation directory for use by the application. If the keyword <b>regen</b> is used, the script regenerates the SSL certificate based on the local hostname of the server. Regardless of the value used for this parameter, if the hostname of the server matches that of the Security Manager application files, no actions are taken on the certificates. See also <a href="#">Security Certificates for SSL, page 4-2</a> . |

The **offline** script syntax for Windows Server 2012 , 2012R2 is shown below:

---

Windows Server 2012 , 2012R2 Syntax for Veritas 6.0.1, Veritas 6.0.2 and Veritas 6.1:

```
perl offline.pl CSManager <PathName> <EventIPAddress>
```

For example:

```
perl offline.pl CSManager F:\Progra~1\CSCOpX 192.0.2.1
```

**Note** You must select the Run as administrator option when opening the Command Prompt.

| Syntax           | Description                                                                                                                                                |
|------------------|------------------------------------------------------------------------------------------------------------------------------------------------------------|
| <PathName>       | The Security Manager installation path (for example, “F:\Program Files\CSCOpX”). If the installation path contains spaces, enclose the argument in quotes. |
| <EventIPAddress> | The IP address that the Security Manager application uses for client/server and server/device communications.                                              |

For ease of use, you might want to create an online and offline batch file (for example, online.bat and offline.bat), which includes the appropriate attributes for your configuration.

To perform a manual failover, you can use VEA or the command line to transfer the primary role within your replicated volume group. If both the primary and secondary server are functioning, you can migrate the primary role to the secondary (effectively reversing the direction of replication) or, if the primary server has failed and is unavailable, you can have the secondary server take over the primary role (with or without fast-failback). Refer to the Veritas Volume Replicator administrator’s guide for details.

The following is an outline of the manual failover procedure for a disaster recovery configuration using replication between two servers:

- 
- Step 1** Stop Security Manager on the primary server using the offline.pl script.
  - Step 2** Unassign the drive letter from the volume used for Security Manager on the primary server.
  - Step 3** Migrate ownership from the primary server to the secondary server using the VEA GUI.
  - Step 4** Assign the drive letter for the volume used for Security Manager on the secondary server.
  - Step 5** Start Security Manager on the secondary server using the online.pl script.

**Note**

If you are migrating/failing-over to the secondary server for the first time, you must upgrade the file permissions for the casusers group. This is a one-time activity. For more information, see [Updating Permissions on the Working Volume, page 3-14](#).

---

## Integrating Cisco Secure ACS with Security Manager

As described in the *Installation Guide for Cisco Security Manager*, you can integrate Cisco Secure ACS with Security Manager to provide enhanced authorization for Security Manager users. In an HA/DR configuration, you need to add each Security Manager server involved in the configuration as a AAA client in ACS. When you specify the server in ACS, specify the fixed IP address associated with server’s physical hostname.

If you are using an HA/DR configuration for Security Manager with ACS integration, you should also deploy multiple ACS servers to avoid having ACS become a single point of failure. If you only have one ACS server and it fails, you cannot log in to Security Manager without taking corrective action to either restore ACS or reset the Security Manager server to use local authentication. ACS supports the deployment of a primary ACS along with multiple secondary ACSs, where database replication is used to keep the secondary ACSs synchronized with the primary ACS. Security Manager supports specifying up to three ACSs, so if the first ACS is unavailable, it tries the second, and finally the third, if necessary.

# Upgrading Security Manager

Security Manager upgrades come in various forms:

- Major releases (change in the first number of the release, for example, 3.x to 4.x)
- Minor releases (change in the second digit of the release, for example, 3.1 to 3.2)
- Maintenance releases (change in the third digit of the release, for example, 3.1 to 3.1.1)
- Service packs (identified by a service pack identifier, such as SP2 for Security Manager 3.1)

When you upgrade Security Manager in an HA/DR configuration, the main difference is whether it is necessary to upgrade just the primary server with the active instance of Security Manager or to also upgrade the secondary servers, which have only a spare copy of Security Manager for establishing the correct registry configuration necessary for Security Manager to run on the server. If an upgrade modifies the registry, you must perform the upgrade on all servers in the HA/DR configuration. Normally service packs do not affect the registry, so it is sufficient to install the service pack just on the primary server. For major, minor, or maintenance releases, normally you should upgrade all servers. However, check the readme file or release notes for exceptions to these guidelines.

When upgrading a secondary server, you must mount the spare copy of the Security Manager to the standard \$NMSROOT (such as F:\Program Files\CSCOpX) path used on all servers in the configuration and then install the regular upgrade. This ensures that the registry settings are correct for running the upgraded version of Security Manager on any secondary server.

Before you upgrade, stop VCS on all servers (using **hastop -all -force** on any server in the cluster stops VCS on all servers in the cluster and leaves the application and its resources operational). If you are upgrading on all servers and your configuration uses replication, you should pause or stop the replication during the upgrade and then synchronize the secondary servers after the upgrade is complete.

# Backing Up Security Manager

An HA/DR deployment configuration of Security Manager does not replace the need for backing up Security Manager regularly. The HA/DR configuration protects you against loss of data or application downtime due to hardware failures; however, it does not protect you against user actions such as accidentally or maliciously modifying or deleting important information maintained in Security Manager. Therefore, you should continue to back up the Security Manager database and information files; you can use the backup feature in Security Manager.

You should back up only the primary active instance of Security Manager, not the spare instances associated with secondary servers. Security Manager can be restored on any server in the HA/DR configuration or any server that has the compatible Security Manager application installed.

# Uninstalling Security Manager

To uninstall Security Manager from all servers in the HA/DR configuration, follow these steps:

- 
- Step 1** Make sure Security Manager is running on the primary server in the primary cluster.
  - Step 2** Using the Cluster Explorer, right-click the **APP\_CSManager** resource and uncheck the **critical** check box. You are prompted to switch to read/write mode, so click **Yes** when this dialog box appears.

- Step 3** Right-click the **APP\_CSManager** resource and select **Offline** on the primary server. Wait for Security Manager to go offline.
- Step 4** Perform required maintenance activities, as needed.
- Step 5** Start the daemon manager manually on the server, using the **net start crmdmgtd** command.
- Step 6** The **APP\_CSManager** will come online; check the **critical** check box.
- Step 7** Delete the **APP\_CSManager** resource and then save the VCS configuration.
- Step 8** If you are using replication, stop replication using the VEA GUI.
- Step 9** To uninstall Security Manager on the primary server, choose **Start > All Programs > Cisco Security Manager > Uninstall Cisco Security Manager**.
- Step 10** On the secondary server, import the disk group if not already done, which contains the **cscopx\_spare** volume, using either the VEA GUI or the command line.
- Step 11** Assign the selected drive letter to the **cscopx\_spare** volume using either the VEA GUI.
- Step 12** To uninstall Security Manager on the primary server, choose **Start > All Programs > Cisco Security Manager > Uninstall Cisco Security Manager**.
- Step 13** Repeat Steps 10 through 12 on any other secondary servers or the primary server in a secondary cluster.

**Note**

---

If you do not plan to re-install Security Manager, you should also delete service groups in VCS associated with Security Manager and the Replicated Volume Group if using replication. You should also delete any unneeded volumes and disk groups as well.

---

# Migrating a Non-HA Security Manager to HA

If you have an existing Security Manager installed in a regular non-HA configuration, this section addresses how to migrate that instance to an HA configuration. Use the following steps to perform the migration:

- 
- Step 1** Perform a backup of the existing Security Manager instance as described in the *User Guide for CiscoWorks Common Services 3.2*. See the section entitled *Backing Up Data* in the *Configuring the Server Chapter* available here: [http://www.cisco.com/en/US/docs/net\\_mgmt/cisoworks\\_common\\_services\\_software/3.2/user/guide/admin.html](http://www.cisco.com/en/US/docs/net_mgmt/cisoworks_common_services_software/3.2/user/guide/admin.html)
  - Step 2** Create the desired Security Manager HA or DR deployment environment as described in this document.
  - Step 3** Restore the backup taken from the original Security Manager instance to the primary server in the HA or DR deployment environment as described in the *User Guide for CiscoWorks Common Services 3.2*. See the section entitled “Restoring Data” available at the link above.
  - Step 4** Manually synchronize the database passwords in the registry on any secondary servers with the passwords on the primary server. On the primary server, use the registry editor (**Start > Run > regedit**) to find and note the values for the CWEPWD registry entries under folders cmf, vms, rmeng, and aus under HKEY\_LOCAL\_MACHINE\SOFTWARE\OBDC\OBDC.INI. Edit the CWEPWD registry values on any secondary machine to match those on the primary.
-



## VCS Resource Views for the Reference Configurations

---

This section provides information about Veritas Cluster Server (VCS) resource and service group views for the HA/DR Security Manager configurations described in this document. Figure A-1 through Figure A-5 illustrate the dependencies among resources in a service group or the dependencies among service groups. In the figures, the line between two resources represents a dependency, or parent-child relationship. Resource dependencies specify the order in which resources are brought online and taken offline. During failover, the resources closest to the top of the figure must be taken offline before the resources linked to them are taken offline. Similarly, the resources that appear closest to the bottom of the figure must be brought online before the resources linked to them can come online. A resource that depends on other resources is a parent resource. The figure links a parent resource icon to a child resource icon below it.

# Single Local Cluster (Dual-Node) Configuration

Figure A-1 shows the Veritas Cluster Server (VCS) resource views for a single cluster with two servers in the cluster.

**Figure A-1** Resource View: APP Group (Single Cluster, Dual Node)

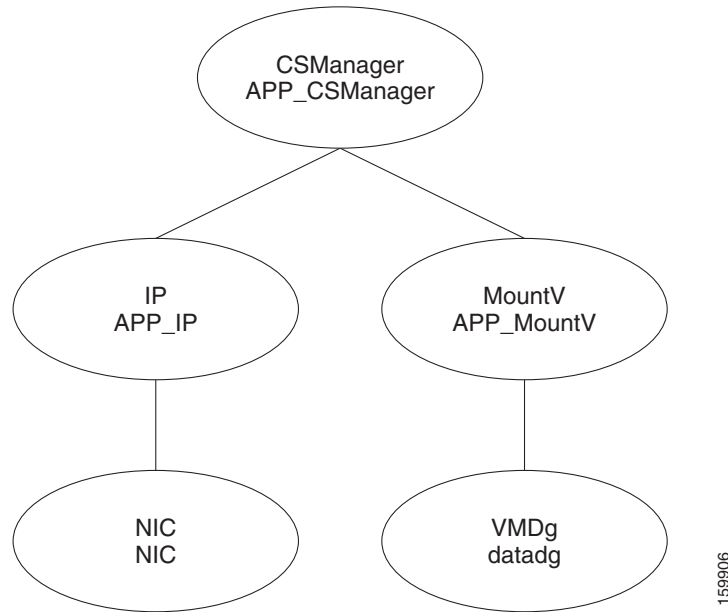



# Dual Geographic Cluster (Single-Node) Configuration

Figure A-2 through Figure A-5 show the Veritas Cluster Server (VCS) resource views for a dual cluster configuration with one server in the cluster.

**Figure A-2 Resource View: APP Group (Dual Cluster, Single Node)**

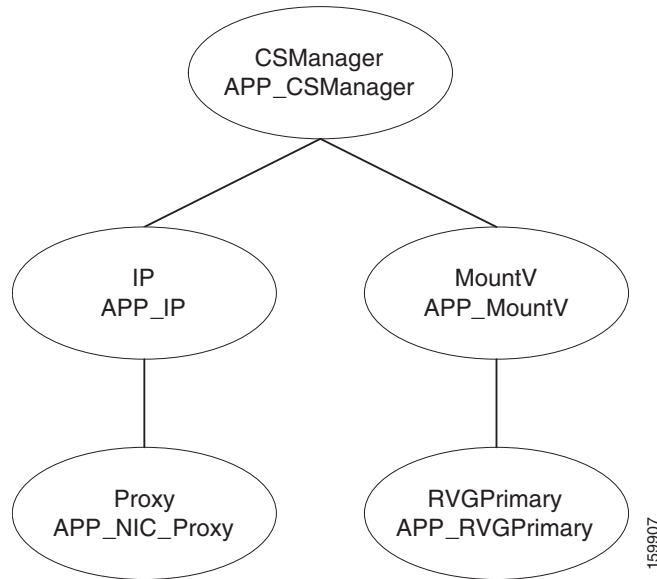

159907

**Figure A-3 Resource View: APPrep Group (Dual Cluster, Single Node)**

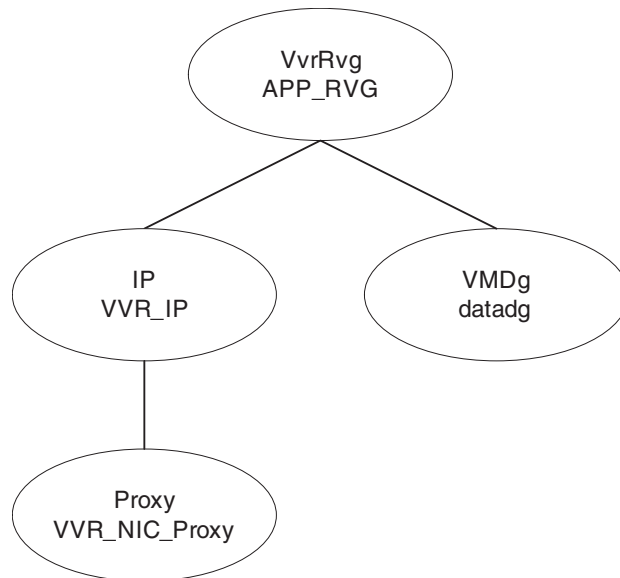

159908

**Figure A-4 Resource View: ClusterService Group (Dual Cluster, Single Node)**

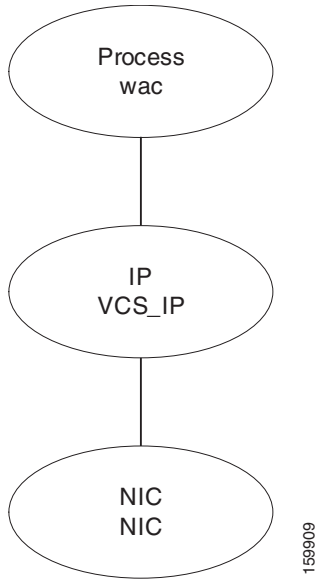

**Figure A-5 Service Group View (Dual Cluster, Single Node)**

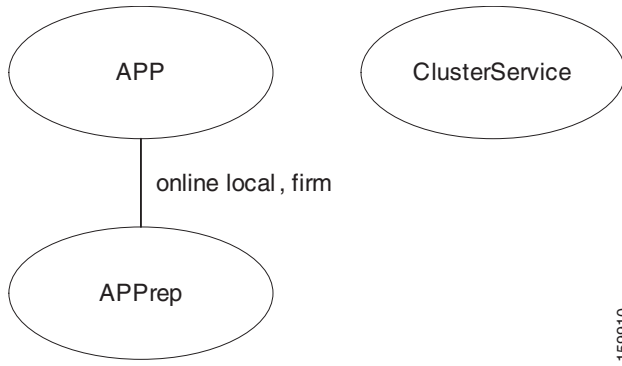



# High Availability and Disaster Recovery Certification Test Plan

---

The HA/DR certification test plan validates that the Security Manager application is highly available and can survive various hardware and software failures. The test plan also covers maintenance activities, such as manually switching the application between servers.



**Note**

---

Security Manager client sessions require active users to log in again after an application failover. This behavior is equivalent to stopping and starting Security Manager services running on the server.

---

The following test case categories are contained in this appendix:

- [Manual Switches, page B-1](#)
- [Ethernet/Network Failures, page B-3](#)
- [Server Failures, page B-10](#)
- [Application Failures, page B-16](#)

## Manual Switches

This section covers two different types of manual switches. In a single cluster with two servers, you can switch between the two servers in the cluster (intracluster switch); in a dual cluster configuration with a single server in each cluster, you can switch between clusters (intercluster switch).

This section contains the following topics:

- [IntraCluster Switch, page B-1](#)
- [InterCluster Switch, page B-2](#)

## IntraCluster Switch

*Test Case Title:* Manual application switch within a cluster.

*Description:* The application is manually switched to a different server in the same cluster using VCS.

*Test Setup:* A dual node cluster ([Figure 1-1 on page 12](#)) in a single cluster configuration.

- 
- Step 1** Ensure that the APP service group is running on the primary server. Using the VCS Cluster Explorer, select the **APP** service group. From the shortcut menu, select **Switch To**, and choose the secondary server. Alternatively, issue the following command:
- ```
C:\> hagr -switch APP -to secondary_server_name
```
- Step 2** From the Resource view of the APP service group, observe that the resources in the service group go offline on the primary server and then come online on the secondary server. Or issue the following command to observe the status of the APP service group.
- ```
C:\> hagr -state APP
```
- Step 3** From a client machine, launch the Security Manager client, using the virtual hostname or IP address in the Server Name field of the login dialog box. Verify that you can log in to the application successfully.
- 

## InterCluster Switch

*Test Case Title:* Manual application switch between clusters.

*Description:* The application is manually switched to a server in a different cluster using VCS.

*Test Setup:* A dual cluster configuration as shown in [Figure 1-2 on page 14](#) with a single server in each cluster.

- 
- Step 1** Using the VCS Cluster Explorer, select the **APP** service group. From the shortcut menu, select **Switch To**, then **Remote Switch(...)**, to open the Switch global dialog box. In the dialog box, specify the remote cluster and, if desired, a specific server in the remote cluster. Alternatively, issue the following command:
- ```
C:\> hagr -switch APP -any -clus secondary_cluster_name
```
- Step 2** From the Resource view of the APP service group, observe that the resources in the service group go offline in the primary cluster. Select the root cluster node in the tree and use the Remote Cluster Status view to see that the APP service group goes online on the remote cluster. Or issue the following command to observe the status of the APP service group.
- ```
C:\> hagr -state APP
#Group Attribute System Value
APP State csm_primary:<Primary Server> |OFFLINE|
APP State localclus:<Secondary Server> |ONLINE|
```
- Step 3** From a client machine, launch the Security Manager client by entering the appropriate hostname or application IP address used in the secondary cluster in the Server Name field of the Login dialog box. Verify that you can successfully log in to the application.
- Step 4** Log out of the Security Manager client, and then switch the APP service group to the primary cluster using either the VCS Cluster Explorer or the following command:
- ```
C:\> hagr -switch APP -any -clus primary_cluster_name
```
-

Ethernet/Network Failures

HA/DR configurations have two types of server Ethernet connections. The first are the Ethernet connections used for network communications (public interfaces); the second are Ethernet interfaces dedicated for intracluster communications (private interfaces). This section covers failure test cases for each type of Ethernet interface.

- [Network Communication Failures, page B-3](#)
- [Cluster Communication Failure, page B-8](#)

Network Communication Failures

This section describes the tests used to verify that VCS can detect failure of the network Ethernet ports used for network communications. This section contains the following topics:

- [Network Ethernet Failure on Secondary Server, Single Cluster, page B-3](#)
- [Network Ethernet Failure on Primary Server, Single Cluster, page B-4](#)
- [Network Ethernet Failure on Secondary Server, Dual Cluster, page B-5](#)
- [Network Ethernet Failure on Primary Server, Dual Cluster, page B-7](#)

Network Ethernet Failure on Secondary Server, Single Cluster

Test Case Title: A failure occurs in the network Ethernet connection on the secondary server in a single cluster configuration.

Description: This test case verifies that VCS can detect a failure on the network Ethernet port on the secondary server and then recover after the failure is repaired.

Test Setup: A dual node cluster ([Figure 1-1 on page 12](#)) in a single cluster configuration with a single network connection per server.

-
- Step 1** Verify that the application is running on the primary server.
- Step 2** Log in to the application from a client machine.
- Step 3** Remove the Ethernet cable from the network port on the secondary server to isolate the server from communicating with the switch/router network. Wait for at least 60 seconds for VCS to detect the network port failure. Verify that VCS detects a failure of the NIC resource on the secondary server by running the following command:

```
C:\> hastatus -sum
-- SYSTEM STATE
-- System          State          Frozen
A <PrimaryServer>  RUNNING       0
A <SecondaryServer> RUNNING       0

-- GROUP STATE
-- Group           System          Probed      AutoDisabled  State
B APP              <PrimaryServer> Y           N             ONLINE
B APP              <SecondaryServer> Y           N             OFFLINE | FAULTED

-- RESOURCES FAILED
-- Group           Type           Resource      System
C APP              NIC            NIC           <SecondaryServer>
```

- Step 4** Restore the Ethernet cable to the network port on the secondary server. Verify that VCS detects that the failure was cleared by running the following command:

```
C:\> hastatus -sum
-- SYSTEM STATE
-- System          State          Frozen
A <PrimaryServer>  RUNNING       0
A <SecondaryServer> RUNNING       0

-- GROUP STATE
-- Group           System          Probed    AutoDisabled  State
B APP              <PrimaryServer> Y         N             ONLINE
B APP              <SecondaryServer> Y         N             OFFLINE
```

Network Ethernet Failure on Primary Server, Single Cluster

Test Case Title: A failure occurs in the network Ethernet connection on the primary server in a single cluster configuration.

Description: This test case verifies that VCS can detect a failure on the network Ethernet port of the primary server and automatically switch the application to the secondary server. After the problem is fixed, you can switch the application back to the primary server manually.

Test Setup: A dual node cluster (Figure 2-2 on page 23) with a single network connection per server.

- Step 1** Verify that the application is running on the primary server.
- Step 2** Remove the Ethernet cable from the network port on the primary server to isolate the server from communicating with the switch/router network. Verify that VCS detects a failure of the NIC resource and automatically switches the APP service group to the secondary server:

```
C:\> hastatus -sum
-- SYSTEM STATE
-- System          State          Frozen
A <PrimaryServer>  RUNNING       0
A <SecondaryServer> RUNNING       0

-- GROUP STATE
-- Group           System          Probed    AutoDisabled  State
B APP              <PrimaryServer> Y         N             OFFLINE | FAULTED
B APP              <SecondaryServer> Y         N             ONLINE

-- RESOURCES FAILED
-- Group           Type            Resource          System
C APP              NIC             NIC               <PrimaryServer>
C APP              IP              APP_IP            <PrimaryServer>
```

- Step 3** Verify that you can log in to the application while it is running on the secondary server.
- Step 4** Replace the Ethernet cable on the network port of the primary server and manually clear the faulted IP resource on the primary server:

```
C:\> hares -clear APP_IP -sys primary_server_name
```

- Step 5** Manually switch the APP service group back to the primary server.

```
C:\> hagrps -switch APP -to primary_server_name
```

Network Ethernet Failure on Secondary Server, Dual Cluster

Test Case Title: A failure occurs in the network Ethernet connection on the secondary server in a dual cluster configuration.

Description: This test case verifies that VCS can detect a failure on the network Ethernet port and then recover after the failure is repaired.

Test Setup: A dual cluster configuration (Figure 1-2 on page 14) with a single node in each cluster and a single Ethernet network connection for each server.

-
- Step 1** Verify that the APP service group is running on the primary cluster/server.
- Step 2** Log in to the Security Manager from a client machine.
- Step 3** Remove the Ethernet cable from the network port on the server in the secondary cluster. This isolates the server from communicating with the switch/router network and interrupts replication. From the primary server, verify that replication was interrupted (disconnected) by running the following command:

```
C:\> vvxprint -Pl
Diskgroup = datadg

Rlink      : rlk_172_6037
info       : timeout=500 packet_size=1400
            latency_high_mark=10000 latency_low_mark=9950
            bandwidth_limit=none
state      : state=ACTIVE
            synchronous=off latencyprot=off srlprot=off
assoc      : rvg=CSM_RVG
            remote_host=172.25.84.34
            remote_dg=datadg
            remote_rlink=rlk_172_32481
            local_host=172.25.84.33
protocol   : UDP/IP
flags      : write attached consistent disconnected
```

- Step 4** Run the following command from the primary server to verify that communication with the secondary cluster was lost:

```
C:\> hastatus -sum
-- SYSTEM STATE
-- System              State              Frozen
A <PrimaryServer>     RUNNING          0

-- GROUP STATE
-- Group              System              Probed      AutoDisabled  State
B APP                 <PrimaryServer>    Y           N             ONLINE
B APPrep             <PrimaryServer>    Y           N             ONLINE
B ClusterService     <PrimaryServer>    Y           N             ONLINE

-- WAN HEARTBEAT STATE
-- Heartbeat          To              State
L Icmp               csm_secondary   ALIVE

-- REMOTE CLUSTER STATE
-- Cluster            State
M csm_secondary     LOST_CONN

-- REMOTE SYSTEM STATE
-- cluster:system      State              Frozen
N csm_secondary:<SecondaryServer>  RUNNING          0
```

```
-- REMOTE GROUP STATE
-- Group          cluster:system      Probed      AutoDisabled  State
O APP csm_secondary:<SecondaryServer> Y           N           OFFLINE
```

Step 5 Reattach the network Ethernet cable to the secondary server and verify that replication resumed.

```
C:\> vxprint -P1
```

```
Diskgroup = datadg
```

```
Rlink      : rlk_172_6037
info       : timeout=29 packet_size=1400
            latency_high_mark=10000 latency_low_mark=9950
            bandwidth_limit=none
state      : state=ACTIVE
            synchronous=off latencyprot=off srlprot=off
assoc      : rvg=CSM_RVG
            remote_host=172.25.84.34
            remote_dg=datadg
            remote_rlink=rlk_172_32481
            local_host=172.25.84.33
protocol   : UDP/IP
flags      : write attached consistent connected
```

Step 6 Verify that communications to the secondary cluster has been restored.

```
C:\> hastatus -sum
```

```
-- SYSTEM STATE
-- System          State          Frozen
A <PrimaryServer>  RUNNING          0
-- GROUP STATE
-- Group          System          Probed      AutoDisabled  State
B APP             <PrimaryServer> Y           N           ONLINE
B APPrep          <PrimaryServer> Y           N           ONLINE
B ClusterService <PrimaryServer> Y           N           ONLINE

-- WAN HEARTBEAT STATE
-- Heartbeat      To          State
L Icmp           csm_secondary ALIVE

-- REMOTE CLUSTER STATE
-- Cluster        State
M csm_secondary  RUNNING

-- REMOTE SYSTEM STATE
-- cluster:system          State          Frozen
N csm_secondary:<SecondaryServer> RUNNING          0

-- REMOTE GROUP STATE
-- Group          cluster:system      Probed      AutoDisabled  State
O APP csm_secondary:<SecondaryServer> Y           N           OFFLINE
```

Step 7 If replication has not recovered you may need to manually clear the IP resource if it has faulted and then start the APPrep service group on the secondary as follows:

```
C:\> hares -clear APP_IP
C:\> hagrps -online APPrep -sys secondary_server_name
```

Network Ethernet Failure on Primary Server, Dual Cluster

Test Case Title: A failure occurs in the network Ethernet connection on the primary server.

Description: This test case verifies that VCS can detect a failure on the primary server network Ethernet port and can recover by starting the application on the secondary server. After the Ethernet connection is restored, you can manually fail over back to the original primary server, retaining any data changes that were made while running on the secondary.

Test Setup: A dual cluster configuration (Figure 1-2 on page 14) with a single node in each cluster.

- Step 1** Verify that the **APP** service group is running on the primary cluster.
- Step 2** Remove the network Ethernet cable from the port on the server in the primary cluster to isolate the server from communicating with the switch/router network. VCS should detect this as a failure of the IP and NIC resources. Verify that VCS detected the failure and brought down the APP service group.

```
C:\> hastatus -sum
-- SYSTEM STATE
-- System                State                Frozen
A <PrimaryServer>      RUNNING              0

-- GROUP STATE
-- Group                System                Probed    AutoDisabled    State
B APP                  <PrimaryServer>      Y         N                OFFLINE
B APPrep              <PrimaryServer>      Y         N                OFFLINE | FAULTED
B ClusterService     <PrimaryServer>      Y         N                ONLINE

-- RESOURCES FAILED
-- Group                Type                Resource                System
C APPrep              IP                  APP_IP                  <PrimaryServer>
C APPrep              NIC                 NIC                      <PrimaryServer>

-- WAN HEARTBEAT STATE
-- Heartbeat            To                State
L Icmp                csm_secondary      DOWN

-- REMOTE CLUSTER STATE
-- Cluster              State
M csm_secondary      FAULTED

-- REMOTE SYSTEM STATE
-- cluster:system        State                Frozen
N csm_secondary:<SecondaryServer> FAULTED              0

-- REMOTE GROUP STATE
-- Group                cluster:system        Probed    AutoDisabled    State
O APP                  csm_secondary:<SecondaryServer> Y         N                OFFLINE
```

- Step 3** Start the APP service group on the secondary cluster using the following command on the secondary server:

```
C:\> hagrpl -online -force APP -sys secondary_server_name
```

- Step 4** From your client machine, log in to Security Manager to verify that it is operational. Change some data so that you can verify that changes are retained when you switch back to the primary server.
- Step 5** Reconnect the network Ethernet cable to the primary cluster server.

- Step 6** Clear any faults on the IP resource and turn on the **APPprep** service from the primary server:
- ```
C:\> hares -clear APP_IP
C:\> hagrps -online APPprep -sys primary_server_name
```
- Step 7** Convert the original primary RVG to secondary and synchronize the data volumes in the original primary RVG with the data volumes on the new primary RVG using the fast failback feature. Using the Cluster Explorer for the secondary cluster, right-click the RVGPrimary resource (**APP\_RVGPrimary**), select **actions**, then select **fbsync** from the Actions dialog box, and then click **OK**. Alternatively, you can issue the following command:
- ```
C:\> hares -action APP_RVGPrimary fbsync 0 -sys secondary_server_name
```
- Step 8** Using the VCS Cluster Explorer on the secondary cluster, select the **APP** service group. From the short-cut menu, select **Switch To**, then **Remote Switch(...)**, to open the Switch global dialog box. In the dialog box, specify the primary cluster and the primary server. Alternatively, issue the following command:
- ```
C:\> hagrps -switch APP -any -clus primarycluster
```
- Step 9** Log in to the application to verify that the changes you made on the secondary server were retained.
- 

## Cluster Communication Failure

*Test Case Title:* Failures occur in the Ethernet used for cluster communication.

*Description:* The dedicated Ethernet connections used between servers in the cluster for intracluster communication fail. The test verifies that the cluster communications continue to function when up to two of the three redundant communication paths are lost.

*Test Setup:* A dual-node cluster (Figure 1-1 on page 12) in a single cluster configuration, with two dedicated cluster communication Ethernet connections and a low-priority cluster communication connection configured on the network Ethernet connection.



### Note

In addition to the commands given in this test case, you can monitor the status of the cluster communications from the Cluster Explorer by selecting the root node in the tree and selecting the System Connectivity tab.

---

- Step 1** Issue the following command to verify that all systems are communicating through GAB.



### Note

Group Membership Services/Atomic Broadcast (GAB) is a VCS protocol responsible for cluster membership and cluster communications.

---

```
gabconfig -a
GAB Port Memberships
=====
Port a gen e8cc02 membership 01
Port h gen e8cc01 membership 01
```

- Step 2** Remove the Ethernet cable from the first dedicated Ethernet port used for cluster communication on the primary server.

**Step 3** Issue the following command to view the detailed status of the links used for cluster communication and verify that the first dedicated cluster communication port is down.

**Note**

The asterisk (\*) in the output indicates the server on which the command is run. The server where the command is run always shows its links up, even if one or more of those ports are the ones that are physically disconnected.

```
lltstat -nvv
LLT node information:
 Node State Link Status Address
 * 0 <PrimaryServer> OPEN
 Adapter0 UP 00:14:5E:28:52:9C
 Adapter1 UP 00:14:5E:28:52:9D
 Adapter2 UP 00:0E:0C:9C:20:FE
 1 <SecondaryServer> OPEN
 Adapter0 DOWN
 Adapter1 UP 00:14:5E:28:27:17
 Adapter2 UP 00:0E:0C:9C:21:C2
...

```

**Step 4** If you configured a low-priority heartbeat link on the network interface, remove the Ethernet cable from the second dedicated Ethernet port used for cluster communication on the primary server.

**Step 5** Issue the following command to verify that all systems are communicating through GAB. Also confirm that both servers in the cluster are now in a Jeopardy state, since each server has only one heartbeat working.

```
gabconfig -a
GAB Port Memberships
=====
Port a gen e8cc02 membership 01
Port a gen e8cc02 jeopardy ;1
Port h gen e8cc01 membership 01
Port h gen e8cc01 jeopardy ;1

```

**Step 6** Issue the following command to view the detailed status of the links used for cluster communication and verify that the second dedicated Ethernet port for cluster communications on the primary server is down.

```
lltstat -nvv
LLT node information:
 Node State Link Status Address
 * 0 <PrimaryServer> OPEN
 Adapter0 UP 00:14:5E:28:52:9C
 Adapter1 UP 00:14:5E:28:52:9D
 Adapter2 UP 00:0E:0C:9C:20:FE
 1 <SecondaryServer> OPEN
 Adapter0 DOWN
 Adapter1 UP 00:14:5E:28:27:17
 Adapter2 DOWN

```

**Step 7** Replace the Ethernet cable on the second dedicated Ethernet port for cluster communications on the primary server.

**Step 8** Verify that the Jeopardy condition was removed by issuing the following command:

```
gabconfig -a
GAB Port Memberships
=====
Port a gen e8cc02 membership 01
Port h gen e8cc01 membership 01
```

**Step 9** Replace the Ethernet cable on the first dedicated Ethernet port for cluster communications on the primary server.

---

## Server Failures

This section covers causing server failures by removing the power from the server to cause a failure. Four cases are covered:

- [Standby Server Failure, Single Cluster, page B-10](#)
- [Primary Server Failure, Single Cluster, page B-11](#)
- [Standby Server Failure, Dual Cluster, page B-12](#)
- [Primary Server Failure, Dual Cluster, page B-14](#)

## Standby Server Failure, Single Cluster

*Test Case Title:* The standby server in a single cluster configuration fails.

*Description:* This test case verifies that the application running in the primary server is unaffected and that after the standby server is repaired, the application can successfully rejoin the cluster configuration.

*Test Setup:* A dual node cluster ([Figure 2-2 on page 23](#)) with two dedicated cluster communication Ethernet connections and a low-priority cluster communication connection on the network Ethernet connection.

**Step 1** Verify that the application is running on the primary server in the cluster.

```
C:\> hastatus -sum
-- SYSTEM STATE
-- System State Frozen
A <PrimaryServer> RUNNING 0
A <SecondaryServer> RUNNING 0

-- GROUP STATE
-- Group System Probed AutoDisabled State
B APP <PrimaryServer> Y N ONLINE
B APP <SecondaryServer> Y N OFFLINE
```

- Step 2** Remove the power for the secondary server and verify that VCS detected the failure and that the application continues to operate on the primary server.

```
C:\> hastatus -sum
-- SYSTEM STATE
-- System State Frozen
A <PrimaryServer> RUNNING 0
A <SecondaryServer> FAULTED 0

-- GROUP STATE
-- Group System Probed AutoDisabled State
B APP <PrimaryServer> Y N ONLINE
```

- Step 3** Reapply power and boot the secondary server. After the server recovers, verify that it rejoined the cluster in a healthy state by running the following command. The output should be identical to the output in Step 1.

```
C:\> hastatus -sum
```

## Primary Server Failure, Single Cluster

*Test Case Title:* The primary server in a single cluster fails.

*Description:* This test case verifies that if a primary server fails, the application starts running on the secondary server and that after the primary server is restored, the application can be reestablished on the primary server.

*Test Setup:* A dual node cluster ([Figure 1-1 on page 12](#)).

- Step 1** Verify that the APP service group is running on the primary server in the cluster by examining the output of the following command:

```
C:\> hastatus -sum
-- SYSTEM STATE
-- System State Frozen
A <PrimaryServer> RUNNING 0
A <SecondaryServer> RUNNING 0

-- GROUP STATE
-- Group System Probed AutoDisabled State
B APP <PrimaryServer> Y N ONLINE
B APP <SecondaryServer> Y N OFFLINE
```

- Step 2** Remove the power from the primary server and verify that VCS detected the failure and that the APP service group automatically moved to the secondary server.

```
C:\> hastatus -sum
-- SYSTEM STATE
-- System State Frozen
A <PrimaryServer> FAULTED 0
A <SecondaryServer> RUNNING 0

-- GROUP STATE
-- Group System Probed AutoDisabled State
B APP <SecondaryServer> Y N ONLINE
```

- Step 3** Verify that you can successfully log in to Security Manager from a client machine.
- Step 4** Restore the power to the primary server and verify that the server can rejoin the cluster in a healthy condition. Run the following command. The output should be identical to the output in Step 1.

```
C:\> hastatus -sum
```

- Step 5** Manually switch the APP service group back to the primary server.

```
C:\> hagrps -switch APP -to primary_server_name
```

## Standby Server Failure, Dual Cluster

*Test Case Title:* The standby server in a dual cluster configuration fails.

*Description:* This test case verifies that an application running in the primary cluster is unaffected by a standby server failure and that after the standby server is repaired, the application can successfully rejoin the dual cluster configuration.

*Test Setup:* A dual cluster configuration, with replication ([Figure 1-2 on page 14](#)), with a single node in each cluster.

- Step 1** Verify that the APP and ClusterService service groups are running in the primary cluster by running the following command on the primary server:

```
C:\> hastatus -sum
-- SYSTEM STATE
-- System State Frozen
A <PrimaryServer> RUNNING 0

-- GROUP STATE
-- Group System Probed AutoDisabled State
B APP <PrimaryServer> Y N ONLINE
B APPrep <PrimaryServer> Y N ONLINE
B ClusterService <PrimaryServer> Y N ONLINE

-- WAN HEARTBEAT STATE
-- Heartbeat To State
L Icmp csm_secondary ALIVE

-- REMOTE CLUSTER STATE
-- Cluster State
M csm_secondary RUNNING

-- REMOTE SYSTEM STATE
-- cluster:system State Frozen
N csm_secondary:<SecondaryServer> RUNNING 0

-- REMOTE GROUP STATE
-- Group cluster:system Probed AutoDisabled State
O APP csm_secondary:<SecondaryServer> Y N OFFLINE
```

- Step 2** Remove the power from the secondary server and verify that the primary cluster detects a loss of communication to the secondary cluster:

```
C:\> hastatus -sum
-- SYSTEM STATE
-- System State Frozen
A <PrimaryServer> RUNNING 0

-- GROUP STATE
-- Group System Probed AutoDisabled State
B APP <PrimaryServer> Y N ONLINE
B APPrep <PrimaryServer> Y N ONLINE
B ClusterService <PrimaryServer> Y N ONLINE

-- WAN HEARTBEAT STATE
-- Heartbeat To State
L Icmp csm_secondary ALIVE

-- REMOTE CLUSTER STATE
-- Cluster State
M csm_secondary LOST_CONN

-- REMOTE SYSTEM STATE
-- cluster:system State Frozen
N csm_secondary:<SecondaryServer> RUNNING 0

-- REMOTE GROUP STATE
-- Group cluster:system Probed AutoDisabled State
O APP csm_secondary:<SecondaryServer> Y N OFFLINE
```

- Step 3** Restore the power to the secondary server. After the server restarts, verify that the primary cluster reestablished communications with the secondary cluster by running the following command. The output should be identical to the output in Step 1.

```
C:\> hastatus -sum
```

- Step 4** Verify that the replication is operational and consistent by running the following command:

```
C:\> vxprint -P1
Diskgroup = BasicGroup

Diskgroup = datadg

Rlink : rlk_172_6037
info : timeout=16 packet_size=1400
 latency_high_mark=10000 latency_low_mark=9950
 bandwidth_limit=none
state : state=ACTIVE
 synchronous=off latencyprot=off srlprot=off
assoc : rvg=CSM_RVG
 remote_host=172.25.84.34
 remote_dg=datadg
 remote_rlink=rlk_172_32481
 local_host=172.25.84.33
protocol : UDP/IP
flags : write attached consistent connected
```

## Primary Server Failure, Dual Cluster

*Test Case Title:* The primary server in a dual cluster configuration fails.

*Description:* This test case verifies that if a primary server fails, the application starts running on the secondary server and that after the primary server is restored, the application can be reestablished on the primary server.

*Test Setup:* A dual cluster configuration, with replication (Figure 1-2 on page 14), with a single node in each cluster.

- Step 1** Verify that the APP and ClusterService service groups are running in the primary cluster by running the following command from the secondary server:

```
C:\> hastatus -sum
-- SYSTEM STATE
-- System State Frozen
A <SecondaryServer> RUNNING 0

-- GROUP STATE
-- Group System Probed AutoDisabled State
B APP <SecondaryServer> Y N OFFLINE
B APPrep <SecondaryServer> Y N ONLINE
B ClusterService <SecondaryServer> Y N ONLINE

-- WAN HEARTBEAT STATE
-- Heartbeat To State
L Icmp csm_primary ALIVE

-- REMOTE CLUSTER STATE
-- Cluster State
M csm_primary RUNNING

-- REMOTE SYSTEM STATE
-- cluster:system State Frozen
N csm_primary:<PrimaryServer> RUNNING 0

-- REMOTE GROUP STATE
-- Group cluster:system Probed AutoDisabled State
O APP csm_primary:<PrimaryServer> Y N ONLINE
```

- Step 2** Remove the power from the primary server to cause a server failure. Verify that the secondary cluster reported a loss of connectivity to the primary cluster.

```
C:\> hastatus -sum
-- SYSTEM STATE
-- System State Frozen
A <SecondaryServer> RUNNING 0

-- GROUP STATE
-- Group System Probed AutoDisabled State
B APP <SecondaryServer> Y N OFFLINE
B APPrep <SecondaryServer> Y N ONLINE
B ClusterService <SecondaryServer> Y N ONLINE

-- WAN HEARTBEAT STATE
-- Heartbeat To State
L Icmp csm_primary ALIVE

-- REMOTE CLUSTER STATE
-- Cluster State
M csm_primary LOST_CONN
```



```
-- REMOTE SYSTEM STATE
-- cluster:system State Frozen
N csm_primary:<PrimaryServer> RUNNING 0

-- REMOTE GROUP STATE
-- Group cluster:system Probed AutoDisabled State
O APP csm_primary:<PrimaryServer> Y N ONLINE
```

**Step 3** Confirm that the state of the replication is disconnected. You can see this state from the **flags** parameter in the output of the following command:

```
C:\> vxprint -P1
Diskgroup = BasicGroup

Diskgroup = datadg

Rlink : rlk_172_32481
info : timeout=500 packet_size=1400
 latency_high_mark=10000 latency_low_mark=9950
 bandwidth_limit=none
state : state=ACTIVE
 synchronous=off latencyprot=off srlprot=off
assoc : rvg=CSM_RVG
 remote_host=172.25.84.33
 remote_dg=datadg
 remote_rlink=rlk_172_6037
 local_host=172.25.84.34
protocol : UDP/IP
flags : write attached consistent disconnected
```

**Step 4** Start the application on the secondary server by using the following command.

```
C:\> hagrps -online -force APP -sys secondary_server_name
```

**Step 5** Log in to the application and change some data so that you can verify later that changes made while the application operating on the secondary server can be retained when you revert to the primary server.

**Step 6** Restore power to the primary server and allow the server to fully start up.

**Step 7** Verify the status of the replication to show that the replication is connected; however, the two sides are not synchronized.

```
C:\> vxprint -P1
Diskgroup = BasicGroup

Diskgroup = datadg

Rlink : rlk_172_32481
info : timeout=500 packet_size=1400
 latency_high_mark=10000 latency_low_mark=9950
 bandwidth_limit=none
state : state=ACTIVE
 synchronous=off latencyprot=off srlprot=off
assoc : rvg=CSM_RVG
 remote_host=172.25.84.33
 remote_dg=datadg
 remote_rlink=rlk_172_6037
 local_host=172.25.84.34
protocol : UDP/IP
flags : write attached consistent connected dcm_logging failback_logging
```

**Step 8** Convert the original primary RVG to secondary and synchronize the data volumes in the original primary RVG with the data volumes on the new primary RVG using the fast failback feature. Using the Cluster Explorer for the secondary cluster, right-click the RVGPrimary resource (**APP\_RVGPrimary**), select **actions**, then select **fbsync** from the Actions dialog box, and then click **OK**. Alternatively you can issue the following command:

```
C:\> hares -action APP_RVGPrimary fbsync 0 -sys secondary_server_name
```

**Step 9** Verify that the current secondary (former primary) is synchronized with the current primary (former secondary) by looking for the keyword **consistent** in the **flags** parameter of the output of the following command:

```
C:\> vxprint -P1
Diskgroup = BasicGroup

Diskgroup = datadg

Rlink : rlk_172_32481
info : timeout=29 packet_size=1400
 : latency_high_mark=10000 latency_low_mark=9950
 : bandwidth_limit=none
state : state=ACTIVE
 : synchronous=off latencyprot=off srlprot=off
assoc : rvg=CSM_RVG
 : remote_host=172.25.84.33
 : remote_dg=datadg
 : remote_rlink=rlk_172_6037
 : local_host=172.25.84.34
protocol : UDP/IP
flags : write attached consistent connected
```

**Step 10** Using the VCS Cluster Explorer on the secondary cluster, select the **APP** service group. From the shortcut menu, select **Switch To**, then **Remote Switch(...)** to open the Switch global dialog box. In the dialog box specify the primary cluster and the primary server. Alternately issue the following command, where *primarycluster* is the name of the primary cluster:

```
C:\> hagrps -switch APP -any -clus primarycluster
```

**Step 11** Log in to the application to verify that the changes you made on the secondary server were retained.

## Application Failures

This section covers test cases where the Security Manager application fails. Two cases are covered: a single cluster configuration and a dual cluster configuration. This section contains the following topics:

- [Application Failure, Single Cluster, page B-16](#)
- [Application Failure, Dual Cluster, page B-17](#)

### Application Failure, Single Cluster

*Test Case Title:* The application fails on the primary server in a single cluster configuration.

*Description:* This test case verifies that VCS detects an application failure and that VCS automatically moves the application to the secondary server.

*Test Setup:* A dual node cluster (Figure 1-1 on page 12) using the default application failover behavior.

- Step 1** Verify that the APP service group is running on the primary server in the cluster by running the following command:

```
C:\> hastatus -sum
-- SYSTEM STATE
-- System State Frozen
A <PrimaryServer> RUNNING 0
A <SecondaryServer> RUNNING 0

-- GROUP STATE
-- Group System Probed AutoDisabled State
B APP <PrimaryServer> Y N ONLINE
B APP <SecondaryServer> Y N OFFLINE
```

- Step 2** On the server where Security Manager is running, stop the application by issuing the following command:

```
C:\> net stop crmdmgt
```

- Step 3** Verify that VCS detects that Security Manager failed on the primary server and starts the application on the secondary server.

```
hastatus -sum
-- SYSTEM STATE
-- System State Frozen
A <PrimaryServer> RUNNING 0
A <SecondaryServer> RUNNING 0

-- GROUP STATE
-- Group System Probed AutoDisabled State
B APP <PrimaryServer> Y N OFFLINE | FAULTED
B APP <SecondaryServer> Y N ONLINE

-- RESOURCES FAILED
-- Group Type Resource System
C APP CSManager APP_CSManager <PrimaryServer>
```

- Step 4** Manually clear the fault on the APP service group.

```
C:\> hagrp -clear APP -sys primary_server_name
```

- Step 5** Manually switch the APP service group back to the primary server.

```
C:\> hagrp -switch APP -to primary_server_name
```

## Application Failure, Dual Cluster

*Test Case Title:* The application fails on the primary server in a dual cluster configuration.

*Description:* This test case verifies that VCS detects an application failure.

*Test Setup:* A dual cluster configuration, with replication (Figure 1-2 on page 14), with a single node in each cluster. Likewise, the assumption is that the default application failover behavior has not been modified (that is, failover between clusters requires manual intervention).

- Step 1** Verify that the APP and ClusterService service groups are running in the primary cluster by running the following command from the primary server:

```
C:\> hastatus -sum
-- SYSTEM STATE
-- System State Frozen
A <SecondaryServer> RUNNING 0

-- GROUP STATE
-- Group System Probed AutoDisabled State
B APP <SecondaryServer> Y N OFFLINE
B APPrep <SecondaryServer> Y N ONLINE
B ClusterService <SecondaryServer> Y N ONLINE

-- WAN HEARTBEAT STATE
-- Heartbeat To State
L Icmp csm_primary ALIVE

-- REMOTE CLUSTER STATE
-- Cluster State
M csm_primary RUNNING

-- REMOTE SYSTEM STATE
-- cluster:system State Frozen
N csm_primary:<PrimaryServer> RUNNING 0

-- REMOTE GROUP STATE
-- Group cluster:system Probed AutoDisabled State
O APP csm_primary:<PrimaryServer> Y N ONLINE
```

- Step 2** On the server where Security Manager is running, stop the application by issuing the following command:

```
C:\> net stop crmdmgt
```

- Step 3** Verify that VCS detects that the application failed and stops the APP service group. Issue the following command and observe the output.

```
hastatus -sum
-- SYSTEM STATE
-- System State Frozen
A <PrimaryServer> RUNNING 0

-- GROUP STATE
-- Group System Probed AutoDisabled State
B APP <PrimaryServer> Y N OFFLINE | FAULTED
B APPrep <PrimaryServer> Y N ONLINE
B ClusterService <PrimaryServer> Y N ONLINE

-- RESOURCES FAILED
-- Group Type Resource System
C APP CSManager APP_CSManager <PrimaryServer>

-- WAN HEARTBEAT STATE
-- Heartbeat To State
L Icmp csm_secondary ALIVE

-- REMOTE CLUSTER STATE
-- Cluster State
M csm_secondary RUNNING

-- REMOTE SYSTEM STATE
```

```
-- cluster:system State Frozen
N csm_secondary:<SecondaryServer> RUNNING 0

-- REMOTE GROUP STATE
-- Group cluster:system Probed AutoDisabled State
0 APP csm_secondary:<SecondaryServer> Y N OFFLINE
```

**Step 4** Manually clear the fault on the APP service group.

```
C:\> hagrp -clear APP
```

**Step 5** Put the APP service group online on the primary server to restart the application.

```
C:\> hagrp -online APP -sys primary_server_name
```

---





---

## A

### ACS

integrating with Security Manager [4-5](#)

---

## B

### boot disk

mirroring [3-3](#)

---

## C

### cautions

significance of [ii-ix](#)

conventions [ii-viii](#)

---

## D

### documentation

audience [ii-vii](#)

conventions [ii-viii](#)

ordering [ii-x](#)

related [ii-ix](#)

---

## E

### Ethernet connections

making [3-1](#)

### external storage

connecting to servers [3-2](#)

---

## M

### Microsoft Windows

installing [3-2](#)

---

## O

overview [1-1](#)

---

## P

### permissions

updating on the working volume [3-14](#)

---

## S

### security guidelines

obtaining [ii-x](#)

### Security Manager

backing up [4-6](#)

installation overview [3-6](#)

installing on secondary servers [3-9](#)

installing on the primary server [3-7](#)

manually starting, stopping, failing over [4-3](#)

uninstalling [4-6](#)

upgrading [4-6](#)

### support

obtaining [ii-x](#)

### Symantec Veritas

see Veritas [3-2](#)

### system requirements

hardware, dual-node site [2-2](#)

hardware, single-node site [2-1](#)

---

software, geographic redundancy [2-4](#)  
software, local redundancy [2-3](#)  
software, replication without clustering [2-4](#)  
understanding [2-1](#)

---

## T

### test plans

application failures [B-16](#)  
Ethernet/network failures [B-3](#)  
manual switches [B-1](#)  
server failures [B-10](#)

---

## V

### Veritas Cluster Server

configuring, dual geographic cluster [3-24](#)  
configuring, single local cluster (dual-node) [3-16](#)  
customizing behavior [4-1](#)  
resource views [A-1](#)

### Veritas Products

installing [3-2](#)  
overview [1-5](#)

### Veritas Volume Manager

configuring primary server (without replication) [3-4](#)  
configuring primary servers (with replication) [3-5](#)  
configuring secondary servers [3-6](#)

### Veritas Volume Replicator

configuring [3-12](#)

---

## W

### warnings

significance of [ii-ix](#)

### worksheets

geographic redundancy [2-6](#)  
local redundancy [2-5](#)