



Cisco Nexus 3548 Switch NX-OS System Management Configuration Guide, Release 9.3(x)

First Published: 2019-07-20

Last Modified: 2021-08-06

Americas Headquarters

Cisco Systems, Inc.
170 West Tasman Drive
San Jose, CA 95134-1706
USA
<http://www.cisco.com>
Tel: 408 526-4000
800 553-NETS (6387)
Fax: 408 527-0883

THE SPECIFICATIONS AND INFORMATION REGARDING THE PRODUCTS REFERENCED IN THIS DOCUMENTATION ARE SUBJECT TO CHANGE WITHOUT NOTICE. EXCEPT AS MAY OTHERWISE BE AGREED BY CISCO IN WRITING, ALL STATEMENTS, INFORMATION, AND RECOMMENDATIONS IN THIS DOCUMENTATION ARE PRESENTED WITHOUT WARRANTY OF ANY KIND, EXPRESS OR IMPLIED.

The Cisco End User License Agreement and any supplemental license terms govern your use of any Cisco software, including this product documentation, and are located at: <http://www.cisco.com/go/softwareterms>. Cisco product warranty information is available at <http://www.cisco.com/go/warranty>. US Federal Communications Commission Notices are found here <http://www.cisco.com/c/en/us/products/us-fcc-notice.html>.

IN NO EVENT SHALL CISCO OR ITS SUPPLIERS BE LIABLE FOR ANY INDIRECT, SPECIAL, CONSEQUENTIAL, OR INCIDENTAL DAMAGES, INCLUDING, WITHOUT LIMITATION, LOST PROFITS OR LOSS OR DAMAGE TO DATA ARISING OUT OF THE USE OR INABILITY TO USE THIS MANUAL, EVEN IF CISCO OR ITS SUPPLIERS HAVE BEEN ADVISED OF THE POSSIBILITY OF SUCH DAMAGES.

Any products and features described herein as in development or available at a future date remain in varying stages of development and will be offered on a when-and if-available basis. Any such product or feature roadmaps are subject to change at the sole discretion of Cisco and Cisco will have no liability for delay in the delivery or failure to deliver any products or feature roadmap items that may be set forth in this document.

Any Internet Protocol (IP) addresses and phone numbers used in this document are not intended to be actual addresses and phone numbers. Any examples, command display output, network topology diagrams, and other figures included in the document are shown for illustrative purposes only. Any use of actual IP addresses or phone numbers in illustrative content is unintentional and coincidental.

The documentation set for this product strives to use bias-free language. For the purposes of this documentation set, bias-free is defined as language that does not imply discrimination based on age, disability, gender, racial identity, ethnic identity, sexual orientation, socioeconomic status, and intersectionality. Exceptions may be present in the documentation due to language that is hardcoded in the user interfaces of the product software, language used based on RFP documentation, or language that is used by a referenced third-party product.

Cisco and the Cisco logo are trademarks or registered trademarks of Cisco and/or its affiliates in the U.S. and other countries. To view a list of Cisco trademarks, go to this URL: [www.cisco.com go trademarks](http://www.cisco.com/go/trademarks). Third-party trademarks mentioned are the property of their respective owners. The use of the word partner does not imply a partnership relationship between Cisco and any other company. (1721R)

© 2019–2024 Cisco Systems, Inc. All rights reserved.



CONTENTS

Trademarks ?

PREFACE

Preface xv

Audience xv

Document Conventions xv

Documentation Feedback xvi

Communications, Services, and Additional Information xvi

CHAPTER 1

New and Changed Information 1

New and Changed Information 1

CHAPTER 2

Overview 3

System Management Features 3

Licensing Requirements 5

Supported Platforms 5

CHAPTER 3

Configuring PTP 7

Information About PTP 7

PTP Device Types 8

PTP Process 9

High Availability for PTP 9

Guidelines and Limitations for PTP 10

Default Settings for PTP 11

Configuring PTP 11

Configuring PTP Globally 11

Configuring PTP on an Interface 13

Configuring Multiple PTP Domains	15
Configuring PTP Grandmaster Clock	18
Configuring PTP Cost Interface	19
Configuring clock Identity	20
Verifying the PTP Configuration	21

CHAPTER 4**Configuring NTP 23**

Information About NTP	23
NTP as a Time Server	24
Distributing NTP Using CFS	24
Clock Manager	24
Virtualization Support	24
Guidelines and Limitations for NTP	24
Default Settings	25
Configuring NTP	25
Configuring NTP Server and Peer	25
Configuring NTP Authentication	27
Configuring NTP Access Restrictions	29
Configuring the NTP Source IP Address	30
Configuring the NTP Source Interface	30
Configuring NTP Logging	31
Enabling CFS Distribution for NTP	32
Committing NTP Configuration Changes	33
Discarding NTP Configuration Changes	33
Releasing the CFS Session Lock	34
Verifying the NTP Configuration	34
Configuration Examples for NTP	35
Related Documents for NTP	37
Feature History for NTP	37

CHAPTER 5**Configuring System Message Logging 39**

Information About System Message Logging	39
Syslog Servers	40
Guidelines and Limitations for System Message Logging	40

Default Settings for System Message Logging	40
Configuring System Message Logging	41
Configuring System Message Logging to Terminal Sessions	41
Configuring System Message Logging to a File	43
Configuring Module and Facility Messages Logging	45
Configuring Logging Timestamps	47
Configuring Syslog Servers	47
Configuring syslog on a UNIX or Linux System	49
Configuring syslog Server Configuration Distribution	50
Displaying and Clearing Log Files	51
Configuring DOM Logging	52
Enabling DOM Logging	52
Disabling DOM Logging	53
Verifying the DOM Logging Configuration	53
Verifying the System Message Logging Configuration	53
Repeated System Logging Messages	54

CHAPTER 6

Configuring Smart Call Home	57
Information About Smart Call Home	57
Smart Call Home Overview	58
Smart Call Home Destination Profiles	58
Smart Call Home Alert Groups	59
Smart Call Home Message Levels	60
Call Home Message Formats	61
Guidelines and Limitations for Smart Call Home	65
Prerequisites for Smart Call Home	65
Default Call Home Settings	65
Configuring Smart Call Home	66
Registering for Smart Call Home	66
Configuring Contact Information	67
Creating a Destination Profile	69
Modifying a Destination Profile	70
Associating an Alert Group with a Destination Profile	71
Adding Show Commands to an Alert Group	72

Configuring E-Mail Server Details	73
Configuring Periodic Inventory Notifications	74
Disabling Duplicate Message Throttling	75
Enabling or Disabling Smart Call Home	76
Testing the Smart Call Home Configuration	77
Verifying the Smart Call Home Configuration	78
Sample Syslog Alert Notification in Full-Text Format	78
Sample Syslog Alert Notification in XML Format	79

CHAPTER 7**Configuring Session Manager 83**

Information About Session Manager	83
Guidelines and Limitations for Session Manager	83
Configuring Session Manager	84
Creating a Session	84
Configuring ACLs in a Session	84
Verifying a Session	85
Committing a Session	85
Saving a Session	85
Discarding a Session	85
Configuration Example for Session Manager	85
Verifying the Session Manager Configuration	86

CHAPTER 8**Configuring the Scheduler 87**

Information About the Scheduler	87
Remote User Authentication	88
Scheduler Log Files	88
Guidelines and Limitations for the Scheduler	88
Default Settings for the Scheduler	88
Configuring the Scheduler	89
Enabling the Scheduler	89
Defining the Scheduler Log File Size	89
Configuring Remote User Authentication	90
Defining a Job	91
Deleting a Job	92

Defining a Timetable	93
Clearing the Scheduler Log File	95
Disabling the Scheduler	95
Verifying the Scheduler Configuration	96
Configuration Examples for the Scheduler	96
Creating a Scheduler Job	96
Scheduling a Scheduler Job	96
Displaying the Job Schedule	97
Displaying the Results of Running Scheduler Jobs	97
Standards for the Scheduler	97

CHAPTER 9

Configuring SNMP	99
Information About SNMP	99
SNMP Functional Overview	99
SNMP Notifications	100
SNMPv3	100
Security Models and Levels for SNMPv1, v2, and v3	100
User-Based Security Model	101
CLI and SNMP User Synchronization	102
Group-Based SNMP Access	103
Guidelines and Limitations for SNMP	103
Default SNMP Settings	103
Configuring SNMP	104
Configuring SNMP Users	104
Enforcing SNMP Message Encryption	105
Assigning SNMPv3 Users to Multiple Roles	105
Creating SNMP Communities	106
Filtering SNMP Requests	106
Configuring SNMP Notification Receivers	106
Configuring SNMP Notification Receivers with VRFs	107
Filtering SNMP Notifications Based on a VRF	108
Configuring SNMP for Inband Access	109
Enabling SNMP Notifications	110
Configuring Link Notifications	112

- Disabling Link Notifications on an Interface 113
- Enabling One-Time Authentication for SNMP over TCP 114
- Assigning SNMP Switch Contact and Location Information 114
- Configuring the Context to Network Entity Mapping 114
- Disabling SNMP 115
- Verifying the SNMP Configuration 116
- Additional References 116

CHAPTER 10

Configuring RMON 117

- Information About RMON 117
 - RMON Alarms 117
 - RMON Events 118
- Configuration Guidelines and Limitations for RMON 118
- Configuring RMON 118
 - Configuring RMON Alarms 118
 - Configuring RMON Events 120
- Verifying the RMON Configuration 120
- Default RMON Settings 121

CHAPTER 11

Configuring Online Diagnostics 123

- Information About Online Diagnostics 123
 - Bootup Diagnostics 123
 - Health Monitoring Diagnostics 124
 - Expansion Module Diagnostics 124
- Configuring Online Diagnostics 125
- Verifying the Online Diagnostics Configuration 126
- Default Settings for Online Diagnostics 126

CHAPTER 12

Configuring Embedded Event Manager 127

- About Embedded Event Manager 127
- Embedded Event Manager Policies 128
 - Event Statements 128
 - Action Statements 129
 - VSH Script Policies 130

Prerequisites for Embedded Event Manager	130
Guidelines and Limitations for Embedded Event Manager	130
Default Settings for Embedded Event Manager	131
Defining an Environment Variable	131
Defining a User Policy Using the CLI	132
Configuring Event Statements	134
Configuring Action Statements	136
Defining a Policy Using a VSH Script	138
Registering and Activating a VSH Script Policy	139
Overriding a System Policy	140
Configuring Syslog as an EEM Publisher	141
Event Log Auto-Collection and Backup	142
Extended Log File Retention	142
Enabling Extended Log File Retention For All Services	142
Disabling Extended Log File Retention For All Services	143
Enabling Extended Log File Retention For a Single Service	144
Displaying Extended Log Files	145
Disabling Extended Log File Retention For a Single Service	146
Trigger-Based Event Log Auto-Collection	147
Enabling Trigger-Based Log File Auto-Collection	147
Auto-Collection YAML File	147
Limiting the Amount of Auto-Collections Per Component	150
Auto-Collection Log Files	150
Verifying Trigger-Based Log Collection	153
Checking Trigger-Based Log File Generation	153
Local Log File Storage	154
Generating a Local Copy of Recent Log Files	154
External Log File Storage	156

CHAPTER 13
Configuring SPAN 159

Information About SPAN	159
Guidelines and Limitations for SPAN	159
SPAN Sources	160
Characteristics of Source Ports	160

- SPAN Destinations 160
- Characteristics of Destination Ports 161
- SPAN and ERSPAN Filtering 161
 - Guidelines and Limitations for SPAN and ERSPAN Filtering 161
 - SPAN and ERSPAN Control-packet Filtering 162
- SPAN and ERSPAN Sampling 163
 - Guidelines and Limitations for SPAN and ERSPAN Sampling 163
- SPAN and ERSPAN Truncation 163
 - Guidelines and Limitations for SPAN and ERSPAN Truncation 163
- Creating or Deleting a SPAN Session 164
- Configuring an Ethernet Destination Port 164
- Configuring Source Ports 165
- Configuring Source Port Channels or VLANs 166
- Configuring the Description of a SPAN Session 167
- Activating a SPAN Session 168
- Suspending a SPAN Session 168
- Configuring a SPAN Filter 169
- Configuring SPAN Sampling 170
- Configuring SPAN Truncation 171
- Displaying SPAN Information 172

CHAPTER 14

- Configuring Warp SPAN 175**
 - Information About Warp SPAN 175
 - Guidelines and Limitations for Warp Span 176
 - Configuring Warp SPAN 177
 - Verifying Warp SPAN Mode Configuration 178
 - Feature History for Warp SPAN 179

CHAPTER 15

- Configuring ERSPAN 181**
 - Information About ERSPAN 181
 - ERSPAN Types 181
 - ERSPAN Sources 181
 - ERSPAN Destinations 182
 - ERSPAN Sessions 182

Multiple ERSPAN Sessions	183
ERSPAN Marker Packet	183
High Availability	183
Prerequisites for ERSPAN	183
Guidelines and Limitations for ERSPAN	184
Default Settings for ERSPAN	185
Configuring ERSPAN	186
Configuring an ERSPAN Source Session	186
Configuring an ERSPAN Destination Session	189
Shutting Down or Activating an ERSPAN Session	191
Configuring ERSPAN Filtering	193
Configuring ERSPAN Sampling	195
Configuring ERSPAN Truncation	196
Configuring an ERSPAN Marker Packet	198
Verifying the ERSPAN Configuration	199
Configuration Examples for ERSPAN	199
Configuration Example for an ERSPAN Source Session	199
Configuration Example for an ERSPAN Destination Session	200
Additional References	200
Related Documents	200

CHAPTER 16
Configuring DNS 201

Information About DNS Client	201
Name Servers	201
DNS Operation	201
High Availability	202
Prerequisites for DNS Clients	202
Default Settings for DNS Clients	202
Configuring DNS Clients	202

CHAPTER 17
Configuring Traffic Forwarding Modes 205

Information About Warp Mode	205
Guidelines and Limitations for Warp Mode	205
Enabling and Disabling Warp Mode	206

Verifying Warp Mode Status	206
Feature History for Warp Mode	207

CHAPTER 18

Configuring Active Buffer Monitoring	209
Information About Active Buffer Monitoring	209
Active Buffer Monitoring Overview	209
Buffer Histogram Data Access and Collection	210
Configuring Active Buffer Monitoring	210
Displaying Buffer Histogram Data	211

CHAPTER 19

Performing Software Maintenance Upgrades (SMUs)	217
About SMUs	217
Package Management	218
Prerequisites for SMUs	218
Guidelines and Limitations for SMUs	219
Performing a Software Maintenance Upgrade for Cisco NX-OS	219
Preparing for Package Installation	219
Copying the Package File to a Local Storage Device or Network Server	220
Adding and Activating Packages	221
Committing the Active Package Set	222
Deactivating and Removing Packages	223
Displaying Installation Log Information	224

CHAPTER 20

Configuring Rollback	227
Information About Rollbacks	227
Guidelines and Limitations for Rollbacks	227
Creating a Checkpoint	228
Implementing a Rollback	229
Verifying the Rollback Configuration	230

CHAPTER 21

Configuring User Accounts and RBAC	231
Information About User Accounts and RBAC	231
User Roles	231
Rules	232

User Role Policies	232
User Account Configuration Restrictions	233
User Password Requirements	233
Guidelines and Limitations for User Accounts	234
Configuring User Accounts	235
Configuring RBAC	236
Creating User Roles and Rules	236
Creating Feature Groups	237
Changing User Role Interface Policies	238
Changing User Role VLAN Policies	239
Verifying the User Accounts and RBAC Configuration	240
Configuring User Accounts Default Settings for the User Accounts and RBAC	240



Preface

The preface contains the following sections:

- [Audience, on page xv](#)
- [Document Conventions, on page xv](#)
- [Documentation Feedback, on page xvi](#)
- [Communications, Services, and Additional Information, on page xvi](#)

Audience

This publication is for network administrators who configure and maintain Cisco Nexus devices.

Document Conventions

Command descriptions use the following conventions:

Convention	Description
bold	Bold text indicates the commands and keywords that you enter literally as shown.
<i>Italic</i>	Italic text indicates arguments for which the user supplies the values.
[x]	Square brackets enclose an optional element (keyword or argument).
[x y]	Square brackets enclosing keywords or arguments separated by a vertical bar indicate an optional choice.
{x y}	Braces enclosing keywords or arguments separated by a vertical bar indicate a required choice.
[x {y z}]	Nested set of square brackets or braces indicate optional or required choices within optional or required elements. Braces and a vertical bar within square brackets indicate a required choice within an optional element.
variable	Indicates a variable for which you supply values, in context where italics cannot be used.

Convention	Description
string	A nonquoted set of characters. Do not use quotation marks around the string or the string will include the quotation marks.

Examples use the following conventions:

Convention	Description
<code>screen font</code>	Terminal sessions and information the switch displays are in screen font.
boldface screen font	Information you must enter is in boldface screen font.
<i>italic screen font</i>	Arguments for which you supply values are in italic screen font.
<>	Nonprinting characters, such as passwords, are in angle brackets.
[]	Default responses to system prompts are in square brackets.
!, #	An exclamation point (!) or a pound sign (#) at the beginning of a line of code indicates a comment line.

Documentation Feedback

To provide technical feedback on this document, or to report an error or omission, please send your comments to: .

We appreciate your feedback.

Communications, Services, and Additional Information

- To receive timely, relevant information from Cisco, sign up at [Cisco Profile Manager](#).
- To get the business impact you're looking for with the technologies that matter, visit [Cisco Services](#).
- To submit a service request, visit [Cisco Support](#).
- To discover and browse secure, validated enterprise-class apps, products, solutions and services, visit [Cisco Marketplace](#).
- To obtain general networking, training, and certification titles, visit [Cisco Press](#).
- To find warranty information for a specific product or product family, access [Cisco Warranty Finder](#).

Cisco Bug Search Tool

[Cisco Bug Search Tool](#) (BST) is a web-based tool that acts as a gateway to the Cisco bug tracking system that maintains a comprehensive list of defects and vulnerabilities in Cisco products and software. BST provides you with detailed defect information about your products and software.



CHAPTER 1

New and Changed Information

This chapter provides release-specific information for each new and changed feature in the *Cisco Nexus 3548 Switch NX-OS System Management Configuration Guide, Release 9.3(x)*.

- [New and Changed Information, on page 1](#)

New and Changed Information

The following table provides an overview of the significant changes to this guide for this current release. The table does not provide an exhaustive list of all changes made to the configuration guides or of the new features in this release.

Table 1:

Feature	Description	Added or Changed in Release	Where Documented
LocalizedV2key	A new keyword “localizedV2key” is introduced to support the old format where the keyword is “localizedkey”. All the SNMP configs will be intact (no config loss/config change) in the process of ISSU/ASCII replay.	9.3(8)	Configuring SNMP Users, on page 104

Feature	Description	Added or Changed in Release	Where Documented
Authentication Protocols for SNMPv3	Provides authentication based on the Hash-Based Message Authentication Code (HMAC) Message Digest 5 (MD5) algorithm or the HMAC Secure Hash Algorithm (SHA). Provides Data Encryption Standard (DES) 56-bit encryption in addition to authentication based on the Cipher Block Chaining (CBC) DES (DES-56) standard.	9.3(8)	Security Models and Levels for SNMPv1, v2, and v3, on page 100 User-Based Security Model, on page 101
Graceful Insertion and Removal (GIR)	GIR is not supported for Nexus 3500 platform	9.3(7)	System Management Features, on page 3
Event Log Auto-Collection and Backup	Updates to the auto-collection YAML file and additional options for the bloggerd log-snapshot command.	9.3(5)	Event Log Auto-Collection and Backup, on page 142
PTP ACL Redirect	Support for PTP unicast forwarding by hardware ACL.	9.3(5)	Configuring PTP Globally, on page 11
Modified Repeated System Logging Message Format	Support for an updated indicator in repeated syslog messages.	9.3(5)	Repeated System Logging Messages, on page 54
Extended Event Log Storage	Introduced support for extended on-switch and off-switch event logging file storage.	9.3(3)	Event Log Auto-Collection and Backup, on page 142
System management features	No updates since Cisco NX-OS Release 9.2(x)	9.3(1)	



CHAPTER 2

Overview

This chapter contains the following sections:

- [System Management Features, on page 3](#)
- [Licensing Requirements, on page 5](#)
- [Supported Platforms, on page 5](#)

System Management Features

The system management features documented in this guide are described below:

Feature	Description
Active Buffer Monitoring	The Active Buffer Monitoring feature provides detailed buffer occupancy data to help you detect network congestion, review past events to understand when and how network congestion is affecting network operations, understand historical trending, and identify patterns of application traffic flow.
Warp Mode	In warp mode, the access path is shortened by consolidating the forwarding table into single table, resulting in faster processing of frames and packets. In warp mode, latency is reduced by up to 20 percent.
User Accounts and RBAC	User accounts and role-based access control (RBAC) allow you to define the rules for an assigned role. Roles restrict the authorization that the user has to access management operations. Each user role can contain multiple rules and each user can have multiple roles.
Session Manager	Session Manager allows you to create a configuration and apply it in batch mode after the configuration is reviewed and verified for accuracy and completeness.

Feature	Description
Online Diagnostics	<p>Cisco Generic Online Diagnostics (GOLD) define a common framework for diagnostic operations across Cisco platforms. The online diagnostic framework specifies the platform-independent fault-detection architecture for centralized and distributed systems, including the common diagnostics CLI and the platform-independent fault-detection procedures for boot-up and run-time diagnostics.</p> <p>The platform-specific diagnostics provide hardware-specific fault-detection tests and allow you to take appropriate corrective action in response to diagnostic test results.</p>
System Message Logging	<p>You can use system message logging to control the destination and to filter the severity level of messages that system processes generate. You can configure logging to a terminal session, a log file, and syslog servers on remote systems.</p> <p>System message logging is based on RFC 3164. For more information about the system message format and the messages that the device generates, see the <i>Cisco NX-OS System Messages Reference</i>.</p>
Smart Call Home	<p>Call Home provides an e-mail-based notification of critical system policies. Cisco NX-OS provides a range of message formats for optimal compatibility with pager services, standard e-mail, or XML-based automated parsing applications. You can use this feature to page a network support engineer, e-mail a Network Operations Center, or use Cisco Smart Call Home services to automatically generate a case with the Technical Assistance Center.</p>
Configuration Rollback	<p>The configuration rollback feature allows users to take a snapshot, or user checkpoint, of the Cisco NX-OS configuration and then reapply that configuration to a switch at any point without having to reload the switch. A rollback allows any authorized administrator to apply this checkpoint configuration without requiring expert knowledge of the features configured in the checkpoint.</p>
SNMP	<p>The Simple Network Management Protocol (SNMP) is an application-layer protocol that provides a message format for communication between SNMP managers and agents. SNMP provides a standardized framework and a common language used for the monitoring and management of devices in a network.</p>

Feature	Description
RMON	RMON is an Internet Engineering Task Force (IETF) standard monitoring specification that allows various network agents and console systems to exchange network monitoring data. Cisco NX-OS supports RMON alarms, events, and logs to monitor Cisco NX-OS devices.
SPAN	The Switched Port Analyzer (SPAN) feature (sometimes called port mirroring or port monitoring) selects network traffic for analysis by a network analyzer. The network analyzer can be a Cisco SwitchProbe, a Fibre Channel Analyzer, or other Remote Monitoring (RMON) probes.
GIR	Graceful Insertion and Removal (GIR) Maintenance mode is not supported on N3500 Platform.

Licensing Requirements

For a complete explanation of Cisco NX-OS licensing recommendations and how to obtain and apply licenses, see the [Cisco NX-OS Licensing Guide](#) and the [Cisco NX-OS Licensing Options Guide](#).

Supported Platforms

Starting with Cisco NX-OS release 7.0(3)I7(1), use the [Nexus Switch Platform Support Matrix](#) to know from which Cisco NX-OS releases various Cisco Nexus 9000 and 3000 switches support a selected feature.



CHAPTER 3

Configuring PTP

This chapter contains the following sections:

- [Information About PTP, on page 7](#)
- [PTP Device Types, on page 8](#)
- [PTP Process, on page 9](#)
- [High Availability for PTP, on page 9](#)
- [Guidelines and Limitations for PTP, on page 10](#)
- [Default Settings for PTP, on page 11](#)
- [Configuring PTP, on page 11](#)

Information About PTP

PTP is a time synchronization protocol for nodes distributed across a network. Its hardware timestamp feature provides greater accuracy than other time synchronization protocols such as the Network Time Protocol (NTP).

A PTP system can consist of a combination of PTP and non-PTP devices. PTP devices include ordinary clocks, boundary clocks, and transparent clocks. Non-PTP devices include ordinary network switches, routers, and other infrastructure devices.

PTP is a distributed protocol that specifies how real-time PTP clocks in the system synchronize with each other. These clocks are organized into a master-slave synchronization hierarchy with the grandmaster clock, which is the clock at the top of the hierarchy, determining the reference time for the entire system. Synchronization is achieved by exchanging PTP timing messages, with the members using the timing information to adjust their clocks to the time of their master in the hierarchy. PTP operates within a logical scope called a PTP domain.

Starting from Cisco NXOS Release 6.0(2)A8(3), PTP supports configuring multiple PTP clocking domains, PTP grandmaster capability, PTP cost on interfaces for slave and passive election, and clock identity.

All the switches in a multi-domain environment, belong to one domain. The switches that are the part of boundary clock, must have multi-domain feature enabled on them. Each domain has user configurable parameters such as domain priority, clock class threshold and clock accuracy threshold. The clocks in each domain remain synchronized with the master clock in that domain. If the GPS in a domain fails, the master clock in the domain synchronizes time and data sets associated with the announce messages from the master clock in the domain where the GPS is active. If the master clock from the highest priority domain does not meet the clock quality attributes, a clock in the subsequent domain that match the criteria is selected. The Best Master Clock Algorithm (BMCA) is used to select the master clock if none of the domains has the desired clock quality attributes. If all the domains have equal priority and the threshold values less than master clock

attributes or if the threshold values are greater than the master clock attributes, BMCA is used to select the master clock.

Grandmaster capability feature controls the switch's ability of propagating its clock to other devices that it is connected to. When the switch receives announce messages on an interface, it checks the clock class threshold and clock accuracy threshold values. If the values of these parameters are within the predefined limits, then the switch acts as per PTP standards specified in IEEE 1588v2. If the switch does not receive announce messages from external sources or if the parameters of the announce messages received are not within the predefined limits, the port state will be changed to listening mode. On a switch with no slave ports, the state of all the PTP enabled ports is rendered as listening and on a switch with one slave port, the BMCA is used to determine states on all PTP enabled ports. Convergence time prevents timing loops at the PTP level when grandmaster capability is disabled on a switch. If the slave port is not selected on the switch, all the ports on the switch will be in listening state for a minimum interval specified in the convergence time. The convergence time range is from 3 to 2600 seconds and the default value is 30 seconds.

The interface cost applies to each PTP enabled port if the switch has more than one path to grandmaster clock. The port with the least cost value is elected as slave and the rest of the ports will remain as passive ports.

The clock identity is a unique 8-octet array presented in the form of a character array based on the switch MAC address. The clock identity is determined from MAC according to the IEEE1588v2-2008 specifications. The clock ID is a combination of bytes in a VLAN MAC address as defined in IEEE1588v2.

PTP Device Types

The following clocks are common PTP devices:

Ordinary clock

Communicates with the network based on a single physical port, similar to an end host. An ordinary clock can function as a grandmaster clock.

Boundary clock

Typically has several physical ports, with each port behaving like a port of an ordinary clock. However, each port shares the local clock, and the clock data sets are common to all ports. Each port decides its individual state, either master (synchronizing other ports connected to it) or slave (synchronizing to a downstream port), based on the best clock available to it through all of the other ports on the boundary clock. Messages that are related to synchronization and establishing the master-slave hierarchy terminate in the protocol engine of a boundary clock and are not forwarded.

Transparent clock

Forwards all PTP messages like an ordinary switch or router but measures the residence time of a packet in the switch (the time that the packet takes to traverse the transparent clock) and in some cases the link delay of the ingress port for the packet. The ports have no state because the transparent clock does not need to synchronize to the grandmaster clock.

There are two kinds of transparent clocks:

End-to-end transparent clock

Measures the residence time of a PTP message and accumulates the times in the correction field of the PTP message or an associated follow-up message.

Peer-to-peer transparent clock

Measures the residence time of a PTP message and computes the link delay between each port and a similarly equipped port on another node that shares the link. For a packet, this incoming link delay is added to the residence time in the correction field of the PTP message or an associated follow-up message.



Note PTP operates only in boundary clock mode. We recommend that you deploy a Grand Master Clock (10 MHz) upstream. The servers contain clocks that require synchronization and are connected to the switch.

End-to-end transparent clock and peer-to-peer transparent clock modes are not supported.

PTP Process

The PTP process consists of two phases: establishing the master-slave hierarchy and synchronizing the clocks.

Within a PTP domain, each port of an ordinary or boundary clock follows this process to determine its state:

- Examines the contents of all received announce messages (issued by ports in the master state)
- Compares the data sets of the foreign master (in the announce message) and the local clock for priority, clock class, accuracy, and so on
- Determines its own state as either master or slave

After the master-slave hierarchy has been established, the clocks are synchronized as follows:

- The master sends a synchronization message to the slave and notes the time it was sent.
- The slave receives the synchronization message and notes the time that it was received. For every synchronization message, there is a follow-up message. The number of sync messages should be equal to the number of follow-up messages.
- The slave sends a delay-request message to the master and notes the time it was sent.
- The master receives the delay-request message and notes the time it was received.
- The master sends a delay-response message to the slave. The number of delay request messages should be equal to the number of delay response messages.
- The slave uses these timestamps to adjust its clock to the time of its master.

High Availability for PTP

Stateful restarts are not supported for PTP

Guidelines and Limitations for PTP

- In a Cisco Nexus 3500 only environment, PTP clock correction is expected to be in the 1- to 2-digit range, from 1 to 99 nanoseconds. However, in a mixed environment, PTP clock correction is expected to be up to 3 digits, from 100 to 999 nanoseconds.
- Cisco Nexus 3500 Series switches support mixed non-negotiated mode of operation on master PTP ports. Meaning that when a slave client sends unicast delay request PTP packet, the Cisco Nexus 3500 responds with an unicast delay response packet. And, if the slave client sends multicast delay request PTP packet, the Cisco Nexus 3500 responds with a multicast delay response packet. For mixed non-negotiated mode to work, the source IP address used in the `ptp source <IP address>` configuration on the BC device must also be configured on any physical or logical interface of the BC device. The recommended best practice is to use the loopback interface of the device.
- Cisco Nexus 3500 Series switches support a maximum of 48 PTP sessions.
- Cisco Nexus 3500 Series switches do not support PTP on 40G interfaces.
- PTP operates only in boundary clock mode. End-to-end transparent clock and peer-to-peer transparent clock modes are not supported.
- PTP operates when the clock protocol is set to PTP. Configuring PTP and NTP together is not supported.
- PTP supports transport over User Datagram Protocol (UDP). Transport over Ethernet is not supported.
- PTP supports only multicast communication. Negotiated unicast communication is not supported.
- PTP is limited to a single domain per network.
- When **ptp acl-redirect** is configured, PTP management packets are software forwarded. The management packets are expected to be within 100 packets/second to avoid CoPP drops.
- PTP-capable ports do not identify PTP packets and do not time-stamp or redirect those packets to CPU for processing unless you enable PTP on those ports. This means that if the PTP is disabled on a port, then the device will be capable of routing any multicast PTP packets, regardless of their type, assuming that there is a multicast state present for this. None of these multicast PTP packets from this port will be redirected to CPU for processing, because the exception used to redirect them to the CPU is programmed on a per-port basis, based on whether the PTP is enabled or not on the respective port.
- 1 pulse per second (1 PPS) input is not supported.
- PTP over IPv6 is not supported.
- Cisco Nexus switches should be synchronized from the neighboring master using a synchronization log interval that ranges from -3 to 1.
- All unicast and multicast PTP management messages will be forwarded as per the forwarding rules. All PTP management messages will be treated as regular multicast packets and process these in the same way as the other non-PTP multicast packets are processed by Cisco Nexus 3500 switches.
- You must configure the incoming port as L3/SVI to enable forwarding of the PTP unicast packets.
- We recommend that Cisco Nexus 3500 switches do not participate in unicast negotiation between the unicast master and clients.
- One-step PTP is not supported on Cisco Nexus 3500 series platform switches.

Default Settings for PTP

The following table lists the default settings for PTP parameters.

Table 2: Default PTP Parameters

Parameters	Default
PTP	Disabled
PTP version	2
PTP domain	0. PTP multi domain is disabled by default.
PTP priority 1 value when advertising the clock	255
PTP priority 2 value when advertising the clock	255
PTP announce interval	1 log second
PTP sync interval	1 log second
PTP announce timeout	3 announce intervals
PTP minimum delay request interval	1 log second
PTP VLAN	1

Configuring PTP

Configuring PTP Globally

You can enable or disable PTP globally on a device. You can also configure various PTP clock parameters to help determine which clock in the network has the highest priority to be selected as the grandmaster.

SUMMARY STEPS

1. **configure terminal**
2. **[no] feature ptp**
3. **[no] ptp source *ip-address***
4. (Optional) **[no] ptp domain *number***
5. (Optional) **[no] ptp priority1 *value***
6. (Optional) **[no] ptp priority2 *value***
7. (Optional) **[no] ptp acl-redirect**
8. (Optional) **show ptp brief**
9. (Optional) **show ptp clock**
10. **copy running-config startup-config**

DETAILED STEPS

	Command or Action	Purpose
Step 1	configure terminal Example: switch# configure terminal	Enters global configuration mode.
Step 2	[no] feature ptp Example: switch(config) # feature ptp	Enables or disables PTP on the device. Note Enabling PTP on the switch does not enable PTP on each interface.
Step 3	[no] ptp source ip-address Example: switch(config) # ptp source 10.2.3.4	Configures the source IP address for all PTP packets. <i>ip-address</i> : IPv4 format.
Step 4	(Optional) [no] ptp domain number Example: switch(config) # ptp domain 24	Configures the domain number to use for this clock. PTP domains allow you to use multiple independent PTP clocking subdomains on a single network. <i>number</i> : Range is from 0 to 128.
Step 5	(Optional) [no] ptp priority1 value Example: switch(config) # ptp priority1 10	Configures the priority1 value to use when advertising this clock. This value overrides the default criteria (clock quality, clock class, and so on) for the best master clock selection. Lower values take precedence. <i>value</i> : Range is from 0 to 255.
Step 6	(Optional) [no] ptp priority2 value Example: switch(config) # ptp priority2 20	Configures the priority2 value to use when advertising this clock. This value is used to decide between two devices that are otherwise equally matched in the default criteria. For example, you can use the priority2 value to give a specific switch priority over other identical switches. <i>value</i> : Range is from 0 to 255.
Step 7	(Optional) [no] ptp acl-redirect Example: switch (config)# ptp acl-redirect	Configures the system to forward PTP unicast packets in hardware using ACL entries. Note Make sure that the TCAM SUP region size is greater than 48 or the following error message is display when you attempt to enter the command: <pre>switch(config)# ptp acl-redirect ERROR: PTP acl-redirect supported only if TCAM sup size is greater than 48 2020 May 6 21:27:04 switch %ACLQOS-SLOT1-2-ACLQOS_OOTR: Tcam resource exhausted: Need to reconfigure SUP region</pre>
Step 8	(Optional) show ptp brief Example:	Displays the PTP status.

	Command or Action	Purpose
	switch(config) # show ptp brief	
Step 9	(Optional) show ptp clock Example: switch(config) # show ptp clock	Displays the properties of the local clock.
Step 10	copy running-config startup-config Example: switch(config) # copy running-config startup-config	Saves the change persistently through reboots and restarts by copying the running configuration to the startup configuration.

Example

The following example shows how to configure PTP globally on the device, specify the source IP address for PTP communications, and configure a preference level for the clock:

```
switch# configure terminal
switch(config)# feature ptp
switch(config)# ptp source 10.10.10.1
switch(config)# ptp priority1 1
switch(config)# ptp priority2 1
switch(config)# show ptp brief
PTP port status
-----
Port State
-----
switch(config)# show ptp clock
PTP Device Type: Boundary clock
Clock Identity : 0:22:55:ff:ff:79:a4:c1
Clock Domain: 0
Number of PTP ports: 0
Priority1 : 1
Priority2 : 1
Clock Quality:
Class : 248
Accuracy : 254
Offset (log variance) : 65535
Offset From Master : 0
Mean Path Delay : 0
Steps removed : 0
Local clock time:Sun Jul 3 14:13:24 2011
switch(config)#
```

Configuring PTP on an Interface

After you globally enable PTP, it is not enabled on all supported interfaces by default. You must enable PTP interfaces individually.

Before you begin

Make sure that you have globally enabled PTP on the switch and configured the source IP address for PTP communication.

SUMMARY STEPS

1. switch# **configure terminal**
2. switch(config) # **interface ethernet slot/port**
3. switch(config-if) # **[no] feature ptp**
4. (Optional) switch(config-if) # **[no] ptp announce {interval log seconds | timeout count}**
5. (Optional) switch(config-if) # **[no] ptp delay request minimum interval log seconds**
6. (Optional) switch(config-if) # **[no] ptp sync interval log seconds**
7. (Optional) switch(config-if) # **[no] ptp vlan vlan-id**
8. (Optional) switch(config-if) # **show ptp brief**
9. (Optional) switch(config-if) # **show ptp port interface interface slot/port**
10. (Optional) switch(config-if)# **copy running-config startup-config**

DETAILED STEPS

	Command or Action	Purpose
Step 1	switch# configure terminal	Enters global configuration mode.
Step 2	switch(config) # interface ethernet slot/port	Specifies the interface on which you are enabling PTP and enters interface configuration mode.
Step 3	switch(config-if) # [no] feature ptp	Enables or disables PTP on an interface.
Step 4	(Optional) switch(config-if) # [no] ptp announce {interval log seconds timeout count}	Configures the interval between PTP announce messages on an interface or the number of PTP intervals before a timeout occurs on an interface. The range for the PTP announcement interval is from 0 to 4 seconds, and the range for the interval timeout is from 2 to 10.
Step 5	(Optional) switch(config-if) # [no] ptp delay request minimum interval log seconds	Configures the minimum interval allowed between PTP delay-request messages when the port is in the master state. The range is from log(-6) to log(1) seconds. Where, log(-2) = 2 frames per second.
Step 6	(Optional) switch(config-if) # [no] ptp sync interval log seconds	Configures the interval between PTP synchronization messages on an interface. The range for the PTP synchronization interval is from -3 log second to 1 log second
Step 7	(Optional) switch(config-if) # [no] ptp vlan vlan-id	Specifies the VLAN for the interface where PTP is being enabled. You can only enable PTP on one VLAN on an interface. The range is from 1 to 4094.
Step 8	(Optional) switch(config-if) # show ptp brief	Displays the PTP status.
Step 9	(Optional) switch(config-if) # show ptp port interface interface slot/port	Displays the status of the PTP port.

	Command or Action	Purpose
Step 10	(Optional) switch(config-if)# copy running-config startup-config	Saves the change persistently through reboots and restarts by copying the running configuration to the startup configuration.

Example

This example shows how to configure PTP on an interface and configure the intervals for the announce, delay-request, and synchronization messages:

```
switch# configure terminal
switch(config)# interface ethernet 2/1
switch(config-if)# ptp
switch(config-if)# ptp announce interval 3
switch(config-if)# ptp announce timeout 2
switch(config-if)# ptp delay-request minimum interval 4
switch(config-if)# ptp sync interval -1
switch(config-if)# show ptp brief
PTP port status
-----
Port State
-----
Eth2/1 Master
switch(config-if)# show ptp port interface ethernet 1/1
PTP Port Dataset: Eth1/1
Port identity: clock identity: f4:4e:05:ff:fe:84:7e:7c
Port identity: port number: 0
PTP version: 2
Port state: Slave
VLAN info: 1
Delay request interval(log mean): 0
Announce receipt time out: 3
Peer mean path delay: 0
Announce interval(log mean): 1
Sync interval(log mean): 1
Delay Mechanism: End to End
Cost: 255
Domain: 5
switch(config-if)#
```

Configuring Multiple PTP Domains

You can configure multiple PTP clocking domains on a single network. Each domain has a priority value associated with it. The default value is 255.

SUMMARY STEPS

1. switch# **configure terminal**
2. switch(config) # **[no] feature ptp**
3. switch(config) # **[no] ptp source ip-address [vrf vrf]**
4. switch(config) # **[no] ptp multi-domain**
5. switch(config) # **[no] ptp domain value priority value**
6. switch(config) # **[no] ptp domain value clock-class-threshold value**
7. switch(config) # **[no] ptp domain value clock-accuracy-threshold value**

8. switch(config) # [no] **ptp multi-domain transition-attributes priority1** *value*
9. switch(config) # [no] **ptp multi-domain transition-attributes priority2** *value*
10. switch(config-if) # [no] **ptp domain** *value*

DETAILED STEPS

	Command or Action	Purpose
Step 1	switch# configure terminal	Enters global configuration mode.
Step 2	switch(config) # [no] feature ptp	Enables or disables PTP on the device. Note Enabling PTP on the switch does not enable PTP on each interface.
Step 3	switch(config) # [no] ptp source <i>ip-address</i> [vrf <i>vrf</i>]	Configures the source IP address for all PTP packets. The <i>ip-address</i> can be in IPv4 format.
Step 4	switch(config) # [no] ptp multi-domain	Enables configuring multi domain feature on the switch. It also allow you to set the attributes such as priority, clock-class threshold , clock-accuracy threshold, transition priorities etc. on the switch.
Step 5	switch(config) # [no] ptp domain <i>value</i> priority <i>value</i>	Specify the values for the domain and priority. The range for the domain <i>value</i> is from 0 to 127. The default value of the domain is 0 The range for the priority <i>value</i> is from 0 to 255. The default value of the priority is 255
Step 6	switch(config) # [no] ptp domain <i>value</i> clock-class-threshold <i>value</i>	Specify the values for domain and clock class threshold. The default value is 248. The range for the domain <i>value</i> is from 0 to 127. The range for the clock-class-threshold <i>value</i> is from 0 to 255. Note It is not necessary that a clock class threshold value ensure election of the slave clock on any ports. The switch uses this value to determine whether the source clock is traceable. If the clock class value from the peer is higher or equal than the <i>clock class threshold</i> value in a domain, the switch runs BMCA to elect the slave port from a domain. If none of the domains has the clock class below the threshold value, the switch runs BMCA on all the PTP enabled ports to elect the best clock.
Step 7	switch(config) # [no] ptp domain <i>value</i> clock-accuracy-threshold <i>value</i>	Specify the values for domain and clock accuracy threshold. The default value is 254. The range for the domain <i>value</i> is from 0 to 127.

	Command or Action	Purpose
		The range for the clock-accuracy-threshold <i>value</i> is from 0 to 255.
Step 8	<code>switch(config) # [no] ptp multi-domain transition-attributes priority1 value</code>	<p>Sets the <i>domain transition-attributes priority1</i> value that is used when sending a packet out from this domain to a peer domain. The value of the <i>priority1</i> in the announce message from the remote port is replaced by the value of <i>domain transition-attributes priority1</i> when the announce message has to be transmitted to a peer in a domain, that is different from that of the slave interface. The default value is 255.</p> <p>The range for the transition-attributes priority1 <i>value</i> is from 0 to 255.</p>
Step 9	<code>switch(config) # [no] ptp multi-domain transition-attributes priority2 value</code>	<p>Sets the <i>domain transition-attributes priority2</i> value that is used when sending a packet out from this domain to a peer domain. The value of the <i>priority2</i> in the announce message from the remote port is replaced by the value of <i>domain transition-attributes priority2</i> when the announce message has to be transmitted to a peer in a domain, that is different from that of the slave interface. The default value is 255.</p> <p>The range for the transition-attributes priority2 <i>value</i> is from 0 to 255.</p>
Step 10	<code>switch(config-if) # [no] ptp domain value</code>	<p>Associates a domain on a PTP enabled interface. If you do not configure the domain specifically on an interface, it takes the default value (0).</p> <p>The range for the domain <i>value</i> is from 0 to 127.</p>

Example

The following example shows the PTP domains configured on a switch:

```
switch(config)# show ptp domain data
MULTI DOMAIN : ENABLED
GM CAPABILITY : ENABLED
PTP DEFAULT DOMAIN : 0
PTP TRANSITION PRIORITY1 : 20
PTP TRANSITION PRIORITY2 : 255
PTP DOMAIN PROPERTY
Domain-Number Domain-Priority Clock-Class Clock-Accuracy Ports
0          255          248          254          Eth1/1
1          1           1           254
switch(config)#
```

The following example shows the domains associated with each PTP enabled interfaces:

```
switch(config)# show ptp interface domain
```

```

PTP port interface domain
-----
Port          Domain
-----
Eth1/1        0
              1          1          254

switch(config)#

```

Configuring PTP Grandmaster Clock

You can configure convergence time to prevent timing loops at the PTP level when grandmaster capability is disabled on a switch. Grandmaster capability is enabled on the device by default.

SUMMARY STEPS

1. switch# **configure terminal**
2. switch(config) # **[no] feature ptp**
3. switch(config) # **[no] ptp source ip-address [vrf vrf]**
4. switch(config) # **no ptp grandmaster-capable [convergence-time]**
5. switch(config) # **[no] ptp domain value clock-class-threshold value**
6. switch(config) # **[no] ptp domain value clock-accuracy-threshold value**
7. switch(config) # **ptp grandmaster-capable**

DETAILED STEPS

	Command or Action	Purpose
Step 1	switch# configure terminal	Enters global configuration mode.
Step 2	switch(config) # [no] feature ptp	Enables or disables PTP on the device. Note Enabling PTP on the switch does not enable PTP on each interface.
Step 3	switch(config) # [no] ptp source ip-address [vrf vrf]	Configures the source IP address for all PTP packets. The <i>ip-address</i> can be in IPv4 format.
Step 4	switch(config) # no ptp grandmaster-capable [convergence-time]	Disables grandmaster capability on the switch. Prevents the device from acting as a grandmaster when there is no external grandmaster available in any domains. The default convergence time is 30 seconds.
Step 5	switch(config) # [no] ptp domain value clock-class-threshold value	Specify the values for domain and clock class threshold. <i>Clock class threshold</i> defines the threshold value of clock class that the device uses to determine whether the source clock can be considered as a grandmaster clock. The range for the domain <i>value</i> is from 0 to 127.

	Command or Action	Purpose
		<p>The range for the clock-class-threshold <i>value</i> is from 0 to 255.</p> <p>Note The switch uses this value to determine whether the source clock is traceable. If the clock class value from all the peers is higher than the clock class threshold value, the BMCA may change all the port state to listening.</p>
Step 6	<pre>switch(config) # [no] ptp domain <i>value</i> clock-accuracy-threshold <i>value</i></pre>	<p>Specify the values for domain and clock accuracy threshold</p> <p>The range for the domain <i>value</i> is from 0 to 127.</p> <p>The range for the clock-accuracy-threshold <i>value</i> is from 0 to 255.</p>
Step 7	<pre>switch(config) # ptp grandmaster-capable</pre>	Enables grandmaster capability on a switch.

Example

The following example displays the PTP clock information:

```
switch(config-if) # show ptp clock
PTP Device Type: Boundary clock
Clock Identity : f4:4e:05:ff:fe:84:7e:7c
Clock Domain: 5
Number of PTP ports: 2
Priority1 : 129
Priority2 : 255
Clock Quality:
Class : 248
Accuracy : 254
Offset (log variance) : 65535
Offset From Master : 0
Mean Path Delay : 391
Steps removed : 1
Local clock time:Wed Nov 9 10:31:21 2016
switch(config-if) #
```

Configuring PTP Cost Interface

You can configure interface cost on each PTP enabled port on a Cisco Nexus 3500 switch. The cost applies to each PTP enabled port if the switch has more than one path to grandmaster clock.

SUMMARY STEPS

1. switch# **configure terminal**
2. switch(config) # **[no] feature ptp**
3. switch(config) # **[no] ptp source ip-address [vrf vrf]**
4. switch(config-if) # **[no] feature ptp**

5. switch(config-if) # [no] ptp cost value

DETAILED STEPS

	Command or Action	Purpose
Step 1	switch# configure terminal	Enters global configuration mode.
Step 2	switch(config) # [no] feature ptp	Enables or disables PTP on the device. Note Enabling PTP on the switch does not enable PTP on each interface.
Step 3	switch(config) # [no] ptp source ip-address [vrf vrf]	Configures the source IP address for all PTP packets. The <i>ip-address</i> can be in IPv4 format.
Step 4	switch(config-if) # [no] feature ptp	Enables or disables PTP on the interface.
Step 5	switch(config-if) # [no] ptp cost value	Associate cost on a PTP enabled interface. The interface having the least cost becomes the slave interface. The range for the cost is from 0 to 255. The default value is 255.

Example

The following example shows cost that is associated with each PTP enabled interfaces:

```
switch(config)# show ptp cost
PTP port costs
-----
Port          Cost
-----
Eth1/1        255
switch(config)#
```

Configuring clock Identity

You can configure clock identity on a Cisco Nexus 3500 switch. The default clock identity is a unique 8-octet array presented in the form of a character array based on the switch MAC address.

SUMMARY STEPS

1. switch# **configure terminal**
2. switch(config) # [no] **feature ptp**
3. switch(config-if) # **ptp clock-identity MAC Address**

DETAILED STEPS

	Command or Action	Purpose
Step 1	switch# configure terminal	Enters global configuration mode.
Step 2	switch(config) # [no] feature ptp	Enables or disables PTP on the device. Note Enabling PTP on the switch does not enable PTP on each interface.
Step 3	switch(config-if) # ptp clock-identity <i>MAC Address</i>	Assigns 6 byte MAC address for PTP clock-identity. Default clock identity is based on the MAC address of the switch. The clock-identity is defined as per IEEE standard (MAC-48 Byte0 MAC-48 Byte1 MAC-48 Byte2 FF FE MAC-48 Bytes3-5).

Verifying the PTP Configuration

Use one of the following commands to verify the configuration:

Table 3: PTP Show Commands

Command	Purpose
show ptp brief	Displays the PTP status.
show ptp clock	Displays the properties of the local clock, including the clock identity.
show ptp clock foreign-masters-record	Displays the state of foreign masters known to the PTP process. For each foreign master, the output displays the clock identity, basic clock properties, and whether the clock is being used as a grandmaster.
show ptp corrections	Displays the last few PTP corrections.
show ptp parent	Displays the properties of the PTP parent.
show ptp port interface ethernet <i>slot/port</i>	Displays the status of the PTP port on the switch.
show ptp domain data	Displays multiple domain data, domain priority, clock threshold and information about grandmaster capabilities.
show ptp interface domain	Displays information about the interface to domain association.
show ptp cost	Displays PTP port to cost association.



CHAPTER 4

Configuring NTP

This chapter contains the following sections:

- [Information About NTP, on page 23](#)
- [NTP as a Time Server, on page 24](#)
- [Distributing NTP Using CFS, on page 24](#)
- [Clock Manager, on page 24](#)
- [Virtualization Support, on page 24](#)
- [Guidelines and Limitations for NTP, on page 24](#)
- [Default Settings, on page 25](#)
- [Configuring NTP, on page 25](#)
- [Related Documents for NTP, on page 37](#)
- [Feature History for NTP, on page 37](#)

Information About NTP

The Network Time Protocol (NTP) synchronizes the time of day among a set of distributed time servers and clients so that you can correlate events when you receive system logs and other time-specific events from multiple network devices. NTP uses the User Datagram Protocol (UDP) as its transport protocol. All NTP communications use Coordinated Universal Time (UTC).

An NTP server usually receives its time from an authoritative time source, such as a radio clock or an atomic clock attached to a time server, and then distributes this time across the network. NTP is extremely efficient; no more than one packet per minute is necessary to synchronize two machines to within a millisecond of each other.

NTP uses a stratum to describe the distance between a network device and an authoritative time source:

- A stratum 1 time server is directly attached to an authoritative time source (such as a radio or atomic clock or a GPS time source).
- A stratum 2 NTP server receives its time through NTP from a stratum 1 time server.

Before synchronizing, NTP compares the time reported by several network devices and does not synchronize with one that is significantly different, even if it is a stratum 1. Because Cisco NX-OS cannot connect to a radio or atomic clock and act as a stratum 1 server, we recommend that you use the public NTP servers available on the Internet. If the network is isolated from the Internet, Cisco NX-OS allows you to configure the time as though it were synchronized through NTP, even though it was not.



Note You can create NTP peer relationships to designate the time-serving hosts that you want your network device to consider synchronizing with and to keep accurate time if a server failure occurs.

The time kept on a device is a critical resource, so we strongly recommend that you use the security features of NTP to avoid the accidental or malicious setting of incorrect time. Two mechanisms are available: an access list-based restriction scheme and an encrypted authentication mechanism.

NTP as a Time Server

the Cisco NX-OS device can use NTP to distribute time. Other devices can configure it as a time server. You can also configure the device to act as an authoritative NTP server, enabling it to distribute time even when it is not synchronized to an outside time source.

Distributing NTP Using CFS

Cisco Fabric Services (CFS) distributes the local NTP configuration to all Cisco devices in the network. After enabling CFS on your device, a network-wide lock is applied to NTP whenever an NTP configuration is started. After making the NTP configuration changes, you can discard or commit them. In either case, the CFS lock is then released from the NTP application.

Clock Manager

Clocks are resources that need to be shared across different processes.

The clock manager allows you to specify the protocol to control the various clocks in the system. Once you specify the protocol, the system clock starts updating.

Virtualization Support

NTP recognizes virtual routing and forwarding (VRF) instances. NTP uses the default VRF if you do not configure a specific VRF for the NTP server and NTP peer.

Guidelines and Limitations for NTP

NTP has the following configuration guidelines and limitations:

- To configure NTP, you must have connectivity to at least one server that is running NTP.
- NTP operates when the clock protocol is set to NTP. Configuring PTP and NTP together is not supported.
- You should have a peer association with another device only when you are sure that your clock is reliable (which means that you are a client of a reliable NTP server).

- A peer configured alone takes on the role of a server and should be used as a backup. If you have two servers, you can configure several devices to point to one server and the remaining devices to point to the other server. You can then configure a peer association between these two servers to create a more reliable NTP configuration.
- If you have only one server, you should configure all the devices as clients to that server.
- You can configure up to 64 NTP entities (servers and peers).
- If CFS is disabled for NTP, then NTP does not distribute any configuration and does not accept a distribution from other devices in the network.
- After CFS distribution is enabled for NTP, the entry of an NTP configuration command locks the network for NTP configuration until a commit command is entered. During the lock, no changes can be made to the NTP configuration by any other device in the network except the device that initiated the lock.
- If you use CFS to distribute NTP, all devices in the network should have the same VRFs configured as you use for NTP.
- If you configure NTP in a VRF, ensure that the NTP server and peers can reach each other through the configured VRFs.
- You must manually distribute NTP authentication keys on the NTP server and Cisco NX-OS devices across the network.

Default Settings

Table 4: Default NTP Parameters

Parameters	Default
NTP authentication	disabled
NTP access	enabled
NTP logging	disabled

Configuring NTP

Configuring NTP Server and Peer

You can configure an NTP server and peer.

Before you begin

Make sure you know the IP address or DNS names of your NTP server and its peers.

If you plan to use CFS to distribute your NTP configuration to other devices, then you should have already completed the following:

- Enabled CFS distribution.
- Enabled CFS for NTP.

SUMMARY STEPS

1. switch# **configure terminal**
2. switch(config)# **[no] ntp server** {*ip-address* | *ipv6-address* | *dns-name*} [**key** *key-id*] [**maxpoll** *max-poll*] [**minpoll** *min-poll*] [**prefer**] [**use-vrf** *vrf-name*]
3. switch(config)# **[no] ntp peer** {*ip-address* | *ipv6-address* | *dns-name*} [**key** *key-id*] [**maxpoll** *max-poll*] [**minpoll** *min-poll*] [**prefer**] [**use-vrf** *vrf-name*]
4. (Optional) switch(config)# **show ntp peers**
5. (Optional) switch(config)# **copy running-config startup-config**

DETAILED STEPS

	Command or Action	Purpose
Step 1	switch# configure terminal	Enters global configuration mode.
Step 2	switch(config)# [no] ntp server { <i>ip-address</i> <i>ipv6-address</i> <i>dns-name</i> } [key <i>key-id</i>] [maxpoll <i>max-poll</i>] [minpoll <i>min-poll</i>] [prefer] [use-vrf <i>vrf-name</i>]	<p>Forms an association with a server.</p> <p>Use the key keyword to configure a key to be used while communicating with the NTP server. The range for the <i>key-id</i> argument is from 1 to 65535.</p> <p>Use the maxpoll and minpoll keywords to configure the maximum and minimum intervals in which to poll a server. The range for the <i>max-poll</i> and <i>min-poll</i> arguments is from 4 to 16 (configured as powers of 2, so effectively 16 to 65536 seconds), and the default values are 6 and 4, respectively (<i>maxpoll</i> default = 64 seconds, <i>minpoll</i> default = 16 seconds).</p> <p>Use the prefer keyword to make this the preferred NTP server for the device.</p> <p>Use the use-vrf keyword to configure the NTP server to communicate over the specified VRF. The vrf-name argument can be default, management, or any case-sensitive alphanumeric string up to 32 characters.</p> <p>Note If you configure a key to be used while communicating with the NTP server, make sure that the key exists as a trusted key on the device.</p>
Step 3	switch(config)# [no] ntp peer { <i>ip-address</i> <i>ipv6-address</i> <i>dns-name</i> } [key <i>key-id</i>] [maxpoll <i>max-poll</i>] [minpoll <i>min-poll</i>] [prefer] [use-vrf <i>vrf-name</i>]	<p>Forms an association with a peer. You can specify multiple peer associations.</p> <p>Use the key keyword to configure a key to be used while communicating with the NTP peer. The range for the <i>key-id</i> argument is from 1 to 65535.</p> <p>Use the maxpoll and minpoll keywords to configure the maximum and minimum intervals in which to poll a server.</p>

	Command or Action	Purpose
		<p>The range for the <i>max-poll</i> and <i>min-poll</i> arguments is from 4 to 17 (configured as powers of 2, so effectively 16 to 131072 seconds), and the default values are 6 and 4, respectively (<i>maxpoll</i> default = 64 seconds, <i>minpoll</i> default = 16 seconds).</p> <p>Use the prefer keyword to make this the preferred NTP server for the device.</p> <p>Use the use-vrf keyword to configure the NTP server to communicate over the specified VRF. The vrf-name argument can be default, management, or any case-sensitive alphanumeric string up to 32 characters.</p>
Step 4	(Optional) switch(config)# show ntp peers	<p>Displays the configured server and peers.</p> <p>Note A domain name is resolved only when you have a DNS server configured.</p>
Step 5	(Optional) switch(config)# copy running-config startup-config	Saves the change persistently through reboots and restarts by copying the running configuration to the startup configuration.

Example

This example shows how to configure an NTP server and peer:

```
switch# config t
Enter configuration commands, one per line. End with CNTL/Z.
switch(config)# ntp server 192.0.2.10 key 10 use-vrf Red
switch(config)# ntp peer 2001:0db8::4101 prefer use-vrf Red
switch(config)# show ntp peers
-----
Peer IP Address Serv/Peer
-----
2001:0db8::4101 Peer (configured)
192.0.2.10 Server (configured)
switch(config)# copy running-config startup-config
[#####] 100%
switch(config)#
```

Configuring NTP Authentication

You can configure the device to authenticate the time sources to which the local clock is synchronized. When you enable NTP authentication, the device synchronizes to a time source only if the source carries one of the authentication keys specified by the **ntp trusted-key** command. The device drops any packets that fail the authentication check and prevents them from updating the local clock. NTP authentication is disabled by default.

Before you begin

Make sure that you configured the NTP server with the authentication keys that you plan to specify in this procedure.

SUMMARY STEPS

1. switch# **configure terminal**
2. switch(config)# **[no] ntp authentication-key number md5 md5-string**
3. (Optional) switch(config)# **show ntp authentication-keys**
4. switch(config)# **[no]ntp trusted-key number**
5. (Optional) switch(config)# **show ntp trusted-keys**
6. switch(config)# **[no] ntp authenticate**
7. (Optional) switch(config)# **show ntp authentication-status**
8. (Optional) switch(config)# **copy running-config startup-config**

DETAILED STEPS

	Command or Action	Purpose
Step 1	switch# configure terminal	Enters global configuration mode.
Step 2	switch(config)# [no] ntp authentication-key number md5 md5-string	Defines the authentication keys. The device does not synchronize to a time source unless the source has one of these authentication keys and the key number is specified by the ntp trusted-key number command.
Step 3	(Optional) switch(config)# show ntp authentication-keys	Displays the configured NTP authentication keys.
Step 4	switch(config)# [no]ntp trusted-key number	Specifies one or more keys that a time source must provide in its NTP packets in order for the device to synchronize to it. The range for trusted keys is from 1 to 65535. This command provides protection against accidentally synchronizing the device to a time source that is not trusted.
Step 5	(Optional) switch(config)# show ntp trusted-keys	Displays the configured NTP trusted keys.
Step 6	switch(config)# [no] ntp authenticate	Enables or disables the NTP authentication feature. NTP authentication is disabled by default.
Step 7	(Optional) switch(config)# show ntp authentication-status	Displays the status of NTP authentication.
Step 8	(Optional) switch(config)# copy running-config startup-config	Saves the change persistently through reboots and restarts by copying the running configuration to the startup configuration.

Example

This example shows how to configure the device to synchronize only to time sources that provide authentication key 42 in their NTP packets:

```

switch# config t
Enter configuration commands, one per line. End with CNTL/Z.
switch(config)# ntp authentication-key 42 md5 aNiceKey
switch(config)# ntp trusted-key 42
switch(config)# ntp authenticate
switch(config)# copy running-config startup-config
[#####] 100%
switch(config)#

```

Configuring NTP Access Restrictions

You can control access to NTP services by using access groups. Specifically, you can specify the types of requests that the device allows and the servers from which it accepts responses.

If you do not configure any access groups, NTP access is granted to all devices. If you configure any access groups, NTP access is granted only to the remote device whose source IP address passes the access list criteria.

SUMMARY STEPS

1. switch# **configure terminal**
2. switch(config)# [**no**] **ntp access-group** {**peer** | **serve** | **serve-only** | **query-only**} *access-list-name*
3. (Optional) switch(config)# **show ntp access-groups**
4. (Optional) switch(config)# **copy running-config startup-config**

DETAILED STEPS

	Command or Action	Purpose
Step 1	switch# configure terminal	Enters global configuration mode.
Step 2	switch(config)# [no] ntp access-group { peer serve serve-only query-only } <i>access-list-name</i>	<p>Creates or removes an access group to control NTP access and applies a basic IP access list.</p> <p>The access group options are scanned in the following order, from least restrictive to most restrictive. However, if NTP matches a deny ACL rule in a configured peer, ACL processing stops and does not continue to the next access group option.</p> <ul style="list-style-type: none"> • The peer keyword enables the device to receive time requests and NTP control queries and to synchronize itself to the servers specified in the access list. • The serve keyword enables the device to receive time requests and NTP control queries from the servers specified in the access list but not to synchronize itself to the specified servers. • The serve-only keyword enables the device to receive only time requests from servers specified in the access list. • The query-only keyword enables the device to receive only NTP control queries from the servers specified in the access list.

	Command or Action	Purpose
Step 3	(Optional) switch(config)# show ntp access-groups	Displays the NTP access group configuration.
Step 4	(Optional) switch(config)# copy running-config startup-config	Saves the change persistently through reboots and restarts by copying the running configuration to the startup configuration.

Example

This example shows how to configure the device to allow it to synchronize to a peer from access group “accesslist1”:

```
switch# config t
switch(config)# ntp access-group peer accesslist1
switch(config)# show ntp access-groups
Access List Type
-----
accesslist1 Peer
switch(config)# copy running-config startup-config
[#####] 100%
switch(config)#
```

Configuring the NTP Source IP Address

NTP sets the source IP address for all NTP packets based on the address of the interface through which the NTP packets are sent. You can configure NTP to use a specific source IP address.

To configure the NTP source IP address, use the following command in global configuration mode:

SUMMARY STEPS

1. switch(config)# **[no] ntp source ip-address**

DETAILED STEPS

	Command or Action	Purpose
Step 1	switch(config)# [no] ntp source ip-address	Configures the source IP address for all NTP packets. The <i>ip-address</i> can be in IPv4 or IPv6 format.

Example

This example shows how to configure NTP to a source IP address:

```
switch(config)# ntp source 192.0.2.1
```

Configuring the NTP Source Interface

You can configure NTP to use a specific interface.

To configure the NTP source interface, use the following command in global configuration mode:

SUMMARY STEPS

1. switch(config)# [no] ntp source-interface *interface*

DETAILED STEPS

	Command or Action	Purpose
Step 1	switch(config)# [no] ntp source-interface <i>interface</i>	Configures the source interface for all NTP packets. Use the ? keyword to display a list of supported interfaces.

Example

This example shows how to configure NTP to a specific interface:

```
switch(config)# ntp source-interface
ethernet 2/1
```

Configuring NTP Logging

You can configure NTP logging in order to generate system logs with significant NTP events. NTP logging is disabled by default.

SUMMARY STEPS

1. switch# **configure terminal**
2. switch(config)# [no] **ntp logging**
3. (Optional) switch(config)# **show ntp logging-status**
4. (Optional) switch(config)# **copy running-config startup-config**

DETAILED STEPS

	Command or Action	Purpose
Step 1	switch# configure terminal	Enters global configuration mode.
Step 2	switch(config)# [no] ntp logging	Enables or disables system logs to be generated with significant NTP events. NTP logging is disabled by default.
Step 3	(Optional) switch(config)# show ntp logging-status	Displays the NTP logging configuration status.
Step 4	(Optional) switch(config)# copy running-config startup-config	Saves the change persistently through reboots and restarts by copying the running configuration to the startup configuration.

Example

This example shows how to enable NTP logging in order to generate system logs with significant NTP events:

```
switch# config t
switch(config)# ntp logging
switch(config)# copy running-config startup-config
[#####] 100%
switch(config)#
```

Enabling CFS Distribution for NTP

You can enable CFS distribution for NTP in order to distribute the NTP configuration to other CFS-enabled devices.

Before you begin

Make sure that you have enabled CFS distribution for the device.

SUMMARY STEPS

1. switch# **configure terminal**
2. switch(config)# **[no] ntp distribute**
3. (Optional) switch(config)# **show ntp status**
4. (Optional) switch(config)# **copy running-config startup-config**

DETAILED STEPS

	Command or Action	Purpose
Step 1	switch# configure terminal	Enters global configuration mode.
Step 2	switch(config)# [no] ntp distribute	Enables or disables the device to receive NTP configuration updates that are distributed through CFS.
Step 3	(Optional) switch(config)# show ntp status	Displays the NTP CFS distribution status.
Step 4	(Optional) switch(config)# copy running-config startup-config	Saves the change persistently through reboots and restarts by copying the running configuration to the startup configuration.

Example

This example shows how to enable CFS distribution for NTP:

```
switch# config t
Enter configuration commands, one per
line. End with CNTL/Z.
switch(config)# ntp distribute
switch(config)# copy running-config
startup-config
```

Committing NTP Configuration Changes

When you commit the NTP configuration changes, the effective database is overwritten by the configuration changes in the pending database and all the devices in the network receive the same configuration.

SUMMARY STEPS

1. switch# **configure terminal**
2. switch(config)# **ntp commit**

DETAILED STEPS

	Command or Action	Purpose
Step 1	switch# configure terminal	Enters global configuration mode.
Step 2	switch(config)# ntp commit	Distributes the NTP configuration changes to all Cisco NX-OS devices in the network and releases the CFS lock. This command overwrites the effective database with the changes made to the pending database.

Example

This example shows how to commit the NTP configuration changes:

```
switch(config)# ntp commit
```

Discarding NTP Configuration Changes

After making the configuration changes, you can choose to discard the changes instead of committing them. If you discard the changes, Cisco NX-OS removes the pending database changes and releases the CFS lock.

To discard NTP configuration changes, use the following command in global configuration mode:

SUMMARY STEPS

1. switch(config)# **ntp abort**

DETAILED STEPS

	Command or Action	Purpose
Step 1	switch(config)# ntp abort	Discards the NTP configuration changes in the pending database and releases the CFS lock. Use this command on the device where you started the NTP configuration.

Example

This example shows how to discard the NTP configuration changes:

```
switch(config)# ntp abort
```

Releasing the CFS Session Lock

If you have performed an NTP configuration and have forgotten to release the lock by either committing or discarding the changes, you or another administrator can release the lock from any device in the network. This action also discards pending database changes.

To release the session lock from any device and discard any pending database changes, use the following command in global configuration mode:

SUMMARY STEPS

1. `switch(config)# clear ntp session`

DETAILED STEPS

	Command or Action	Purpose
Step 1	<code>switch(config)# clear ntp session</code>	Discards the NTP configuration changes in the pending database and releases the CFS lock.

Example

This example shows how to release the CFS session lock:

```
switch(config)# clear ntp session
```

Verifying the NTP Configuration

To display the NTP configuration, perform one of the following tasks:

Use the `clear ntp session` command to clear the NTP sessions.

Use the `clear ntp statistics` command to clear the NTP statistics.

SUMMARY STEPS

1. `show ntp access-groups`
2. `show ntp authentication-keys`
3. `show ntp authentication-status`
4. `show ntp logging-status`
5. `show ntp peer-status`
6. `show ntp peers`
7. `show ntp pending`
8. `show ntp pending-diff`
9. `show ntp rts-update`
10. `show ntp session status`
11. `show ntp source`
12. `show ntp source-interface`
13. `show ntp statistics {io | local | memory | peer {ipaddr {ipv4-addr | ipv6-addr} | name peer-name}}`
14. `show ntp status`

15. `show ntp trusted-keys`
16. `show running-config ntp`

DETAILED STEPS

	Command or Action	Purpose
Step 1	<code>show ntp access-groups</code>	Displays the NTP access group configuration.
Step 2	<code>show ntp authentication-keys</code>	Displays the configured NTP authentication keys.
Step 3	<code>show ntp authentication-status</code>	Displays the status of NTP authentication.
Step 4	<code>show ntp logging-status</code>	Displays the NTP logging status.
Step 5	<code>show ntp peer-status</code>	Displays the status for all NTP servers and peers.
Step 6	<code>show ntp peers</code>	Displays all the NTP peers.
Step 7	<code>show ntp pending</code>	Displays the temporary CFS database for NTP.
Step 8	<code>show ntp pending-diff</code>	Displays the difference between the pending CFS database and the current NTP configuration.
Step 9	<code>show ntp rts-update</code>	Displays the RTS update status.
Step 10	<code>show ntp session status</code>	Displays the NTP CFS distribution session information.
Step 11	<code>show ntp source</code>	Displays the configured NTP source IP address.
Step 12	<code>show ntp source-interface</code>	Displays the configured NTP source interface.
Step 13	<code>show ntp statistics {io local memory peer {ipaddr {ipv4-addr ipv6-addr} name peer-name}}</code>	Displays the NTP statistics.
Step 14	<code>show ntp status</code>	Displays the NTP CFS distribution status.
Step 15	<code>show ntp trusted-keys</code>	Displays the configured NTP trusted keys.
Step 16	<code>show running-config ntp</code>	Displays NTP information.

Configuration Examples for NTP

This example shows how to configure an NTP server and peer, enable NTP authentication, enable NTP logging, and then save the configuration in startup so that it is saved across reboots and restarts:

```
switch# config terminal
Enter configuration commands, one per line. End with CNTL/Z.
switch(config)# ntp server 192.0.2.105 key 42
switch(config)# ntp peer 2001:0db8::4101
switch(config)# show ntp peers
-----
Peer IP Address          Serv/Peer
-----
2001:db8::4101          Peer (configured)
192.0.2.105              Server (configured)
```

```

switch(config)# ntp authentication-key 42 md5 aNiceKey
switch(config)# show ntp authentication-keys
-----
Auth key      MD5 String
-----
      42      aNicekey
switch(config)# ntp trusted-key 42
switch(config)# show ntp trusted-keys
Trusted Keys:
42
switch(config)# ntp authenticate
switch(config)# show ntp authentication-status
Authentication enabled.
switch(config)# ntp logging
switch(config)# show ntp logging
NTP logging enabled.
switch(config)# copy running-config startup-config
[#####] 100%
switch(config)#

```

This example shows an NTP access group configuration with the following restrictions:

- Peer restrictions are applied to IP addresses that pass the criteria of the access list named “peer-acl.”
- Serve restrictions are applied to IP addresses that pass the criteria of the access list named “serve-acl.”
- Serve-only restrictions are applied to IP addresses that pass the criteria of the access list named “serve-only-acl.”
- Query-only restrictions are applied to IP addresses that pass the criteria of the access list named “query-only-acl.”

```

switch# config terminal
switch(config)# ntp peer 10.1.1.1
switch(config)# ntp peer 10.2.2.2
switch(config)# ntp peer 10.3.3.3
switch(config)# ntp peer 10.4.4.4
switch(config)# ntp peer 10.5.5.5
switch(config)# ntp peer 10.6.6.6
switch(config)# ntp peer 10.7.7.7
switch(config)# ntp peer 10.8.8.8
switch(config)# ntp access-group peer peer-acl
switch(config)# ntp access-group serve serve-acl
switch(config)# ntp access-group serve-only serve-only-acl
switch(config)# ntp access-group query-only query-only-acl

switch(config)# ip access-list peer-acl
switch(config-acl)# 10 permit ip host 10.1.1.1 any
switch(config-acl)# 20 permit ip host 10.8.8.8 any

switch(config)# ip access-list serve-acl
switch(config-acl)# 10 permit ip host 10.4.4.4 any
switch(config-acl)# 20 permit ip host 10.5.5.5 any

switch(config)# ip access-list serve-only-acl
switch(config-acl)# 10 permit ip host 10.6.6.6 any
switch(config-acl)# 20 permit ip host 10.7.7.7 any

switch(config)# ip access-list query-only-acl
switch(config-acl)# 10 permit ip host 10.2.2.2 any
switch(config-acl)# 20 permit ip host 10.3.3.3 any

```

Related Documents for NTP

Related Topic	Document Title
NTP CLI commands	<i>Cisco Nexus 3548 Switch NX-OS System Management Command Reference Guide</i>

Feature History for NTP

This table includes only the updates for those releases that have resulted in additions or changes to the feature.

Feature Name	Releases	Feature Information
NTP	5.0(3)A1(1)	This feature was introduced.



CHAPTER 5

Configuring System Message Logging

This chapter contains the following sections:

- [Information About System Message Logging, on page 39](#)
- [Guidelines and Limitations for System Message Logging, on page 40](#)
- [Default Settings for System Message Logging, on page 40](#)
- [Configuring System Message Logging, on page 41](#)
- [Configuring DOM Logging, on page 52](#)
- [Verifying the System Message Logging Configuration, on page 53](#)
- [Repeated System Logging Messages, on page 54](#)

Information About System Message Logging

You can use system message logging to control the destination and to filter the severity level of messages that system processes generate. You can configure logging to terminal sessions, a log file, and syslog servers on remote systems.

System message logging is based on [RFC 3164](#). For more information about the system message format and the messages that the device generates, see the *Cisco NX-OS System Messages Reference*.

By default, the Cisco Nexus device outputs messages to terminal sessions.

By default, the switch logs system messages to a log file.

The following table describes the severity levels used in system messages. When you configure the severity level, the system outputs messages at that level and lower.

Table 5: System Message Severity Levels

Level	Description
0 – emergency	System unusable
1 – alert	Immediate action needed
2 – critical	Critical condition
3 – error	Error condition
4 – warning	Warning condition

Level	Description
5 – notification	Normal but significant condition
6 – informational	Informational message only
7 – debugging	Appears during debugging only

The switch logs the most recent 100 messages of severity 0, 1, or 2 to the NVRAM log. You cannot configure logging to the NVRAM.

You can configure which system messages should be logged based on the facility that generated the message and its severity level.

Syslog Servers

Syslog servers run on remote systems that are configured to log system messages based on the syslog protocol. You can configure the Cisco Nexus Series switch to send logs to up to eight syslog servers.

To support the same configuration of syslog servers on all switches in a fabric, you can use Cisco Fabric Services (CFS) to distribute the syslog server configuration.



Note When the switch first initializes, messages are sent to syslog servers only after the network is initialized.

Guidelines and Limitations for System Message Logging

System message logging has the following configuration guidelines and limitations:

- System messages are logged to the console and the logfile by default.

Default Settings for System Message Logging

The following table lists the default settings for system message logging parameters.

Table 6: Default System Message Logging Parameters

Parameters	Default
Console logging	Enabled at severity level 2
Monitor logging	Enabled at severity level 2
Log file logging	Enabled to log messages at severity level 5
Module logging	Enabled at severity level 5

Parameters	Default
Facility logging	Enabled
Time-stamp units	Seconds
Syslog server logging	Disabled
Syslog server configuration distribution	Disabled

Configuring System Message Logging

Configuring System Message Logging to Terminal Sessions

You can configure the switch to log messages by their severity level to console, Telnet, and Secure Shell sessions.

By default, logging is enabled for terminal sessions.

SUMMARY STEPS

1. switch# **terminal monitor**
2. switch# **configure terminal**
3. switch(config)# **logging console** [*severity-level*]
4. (Optional) switch(config)# **no logging console** [*severity-level*]
5. switch(config)# **logging monitor** [*severity-level*]
6. (Optional) switch(config)# **no logging monitor** [*severity-level*]
7. (Optional) switch# **show logging console**
8. (Optional) switch# **show logging monitor**
9. (Optional) switch# **copy running-config startup-config**

DETAILED STEPS

	Command or Action	Purpose
Step 1	switch# terminal monitor	Copies syslog messages from the console to the current terminal session.
Step 2	switch# configure terminal	Enters global configuration mode.
Step 3	switch(config)# logging console [<i>severity-level</i>]	Enables the switch to log messages to the console session based on a specified severity level or higher (a lower number value indicates a higher severity level). Severity levels range from 0 to 7: <ul style="list-style-type: none"> • 0 – emergency • 1 – alert • 2 – critical

	Command or Action	Purpose
		<ul style="list-style-type: none"> • 3 – error • 4 – warning • 5 – notification • 6 – informational • 7 – debugging <p>If the severity level is not specified, the default of 2 is used.</p>
Step 4	(Optional) switch(config)# no logging console [severity-level]	Disables logging messages to the console.
Step 5	switch(config)# logging monitor [severity-level]	<p>Enables the switch to log messages to the monitor based on a specified severity level or higher (a lower number value indicates a higher severity level). Severity levels range from 0 to 7:</p> <ul style="list-style-type: none"> • 0 – emergency • 1 – alert • 2 – critical • 3 – error • 4 – warning • 5 – notification • 6 – informational • 7 – debugging <p>If the severity level is not specified, the default of 2 is used. The configuration applies to Telnet and SSH sessions.</p>
Step 6	(Optional) switch(config)# no logging monitor [severity-level]	Disables logging messages to Telnet and SSH sessions.
Step 7	(Optional) switch# show logging console	Displays the console logging configuration.
Step 8	(Optional) switch# show logging monitor	Displays the monitor logging configuration.
Step 9	(Optional) switch# copy running-config startup-config	Copies the running configuration to the startup configuration.

Example

The following example shows how to configure a logging level of 3 for the console:

```
switch# configure terminal
switch(config)# logging console 3
```

The following example shows how to display the console logging configuration:

```
switch# show logging console
Logging console:                enabled (Severity: error)
```

The following example shows how to disable logging for the console:

```
switch# configure terminal
switch(config)# no logging console
```

The following example shows how to configure a logging level of 4 for the terminal session:

```
switch# terminal monitor
switch# configure terminal
switch(config)# logging monitor 4
```

The following example shows how to display the terminal session logging configuration:

```
switch# show logging monitor
Logging monitor:                enabled (Severity: warning)
```

The following example shows how to disable logging for the terminal session:

```
switch# configure terminal
switch(config)# no logging monitor
```

Configuring System Message Logging to a File

You can configure the switch to log system messages to a file. By default, system messages are logged to the file log:messages.

SUMMARY STEPS

1. switch# **configure terminal**
2. switch(config)# **logging logfile** *logfile-name severity-level [size bytes]*
3. (Optional) switch(config)# **no logging logfile** [*logfile-name severity-level [size bytes]*]
4. (Optional) switch# **show logging info**
5. (Optional) switch# **copy running-config startup-config**

DETAILED STEPS

	Command or Action	Purpose
Step 1	switch# configure terminal	Enters global configuration mode.
Step 2	switch(config)# logging logfile <i>logfile-name severity-level [size bytes]</i>	Configures the name of the log file used to store system messages and the minimum severity level to log. You can

	Command or Action	Purpose
		<p>optionally specify a maximum file size. The default severity level is 5 and the file size is 4194304.</p> <p>Severity levels range from 0 to 7:</p> <ul style="list-style-type: none"> • 0 – emergency • 1 – alert • 2 – critical • 3 – error • 4 – warning • 5 – notification • 6 – informational • 7 – debugging <p>The file size is from 4096 to 10485760 bytes.</p>
Step 3	(Optional) switch(config)# no logging logfile [<i>logfile-name</i> <i>severity-level</i> [size bytes]]	Disables logging to the log file. You can optionally specify a maximum file size. The default severity level is 5 and the file size is 4194304.
Step 4	(Optional) switch# show logging info	Displays the logging configuration. You can optionally specify a maximum file size. The default severity level is 5 and the file size is 4194304.
Step 5	(Optional) switch# copy running-config startup-config	Copies the running configuration to the startup configuration.

Example

The following example shows how to configure a switch to log system messages to a file:

```
switch# configure terminal
switch(config)# logging logfile my_log 6 size 4194304
```

The following example shows how to display the logging configuration (some of the output has been removed for brevity):

```
switch# show logging info
Logging console:                enabled (Severity: debugging)
Logging monitor:                enabled (Severity: debugging)
Logging timestamp:              Seconds
Logging server:                 disabled
Logging logfile:                enabled
                                Name - my_log: Severity - informational Size - 4194304
Facility      Default Severity      Current Session Severity
-----
aaa           3                               3
afm           3                               3
altos        3                               3
```

```

auth          0          0
authpriv     3          3
bootvar      5          5
callhome     2          2
capability   2          2
cdp          2          2
cert_enroll  2          2
...

```

Configuring Module and Facility Messages Logging

You can configure the severity level and time-stamp units of messages logged by modules and facilities.

SUMMARY STEPS

1. switch# **configure terminal**
2. switch(config)# **logging module** [*severity-level*]
3. switch(config)# **logging level** *facility severity-level*
4. (Optional) switch(config)# **no logging module** [*severity-level*]
5. (Optional) switch(config)# **no logging level** [*facility severity-level*]
6. (Optional) switch# **show logging module**
7. (Optional) switch# **show logging level** [*facility*]
8. (Optional) switch# **copy running-config startup-config**

DETAILED STEPS

	Command or Action	Purpose
Step 1	switch# configure terminal	Enters global configuration mode.
Step 2	switch(config)# logging module [<i>severity-level</i>]	<p>Enables module log messages that have the specified severity level or higher. Severity levels range from 0 to 7:</p> <ul style="list-style-type: none"> • 0 – emergency • 1 – alert • 2 – critical • 3 – error • 4 – warning • 5 – notification • 6 – informational • 7 – debugging <p>If the severity level is not specified, the default of 5 is used.</p>
Step 3	switch(config)# logging level <i>facility severity-level</i>	Enables logging messages from the specified facility that have the specified severity level or higher. Severity levels from 0 to 7:

	Command or Action	Purpose
		<ul style="list-style-type: none"> • 0 – emergency • 1 – alert • 2 – critical • 3 – error • 4 – warning • 5 – notification • 6 – informational • 7 – debugging <p>To apply the same severity level to all facilities, use the all facility. For defaults, see the show logging level command.</p> <p>Note If the default severity and current session severity of a component is the same, then the logging level for the component will not be displayed in the running configuration.</p>
Step 4	(Optional) switch(config)# no logging module [<i>severity-level</i>]	Disables module log messages.
Step 5	(Optional) switch(config)# no logging level [<i>facility severity-level</i>]	Resets the logging severity level for the specified facility to its default level. If you do not specify a facility and severity level, the switch resets all facilities to their default levels.
Step 6	(Optional) switch# show logging module	Displays the module logging configuration.
Step 7	(Optional) switch# show logging level [<i>facility</i>]	Displays the logging level configuration and the system default level by facility. If you do not specify a facility, the switch displays levels for all facilities.
Step 8	(Optional) switch# copy running-config startup-config	Copies the running configuration to the startup configuration.

Example

The following example shows how to configure the severity level of module and specific facility messages:

```
switch# configure terminal
switch(config)# logging module 3
switch(config)# logging level aaa 2
```

Configuring Logging Timestamps

You can configure the time-stamp units of messages logged by the Cisco Nexus Series switch.

SUMMARY STEPS

1. switch# **configure terminal**
2. switch(config)# **logging timestamp** {microseconds | milliseconds | seconds}
3. (Optional) switch(config)# **no logging timestamp** {microseconds | milliseconds | seconds}
4. (Optional) switch# **show logging timestamp**
5. (Optional) switch# **copy running-config startup-config**

DETAILED STEPS

	Command or Action	Purpose
Step 1	switch# configure terminal	Enters global configuration mode.
Step 2	switch(config)# logging timestamp {microseconds milliseconds seconds}	Sets the logging time-stamp units. By default, the units are seconds.
Step 3	(Optional) switch(config)# no logging timestamp {microseconds milliseconds seconds}	Resets the logging time-stamp units to the default of seconds.
Step 4	(Optional) switch# show logging timestamp	Displays the logging time-stamp units configured.
Step 5	(Optional) switch# copy running-config startup-config	Copies the running configuration to the startup configuration.

Example

The following example shows how to configure the time-stamp units of messages:

```
switch# configure terminal
switch(config)# logging timestamp milliseconds
switch(config)# exit
switch# show logging timestamp
Logging timestamp:                      Milliseconds
```

Configuring Syslog Servers

You can configure up to eight syslog servers that reference remote systems where you want to log system messages.

SUMMARY STEPS

1. **configure terminal**
2. **logging server** *host* [*severity-level* [**use-vrf** *vrf-name* [*facility facility*]]]
3. (Optional) **no logging server** *host*
4. (Optional) **show logging server**
5. (Optional) **copy running-config startup-config**

DETAILED STEPS

	Command or Action	Purpose
Step 1	<p>configure terminal</p> <p>Example:</p> <pre>switch# configure terminal switch(config)#</pre>	Enters global configuration mode.
Step 2	<p>logging server <i>host</i> [<i>severity-level</i> [use-vrf <i>vrf-name</i> [<i>facility facility</i>]]]</p> <p>Example:</p> <pre>switch(config)# logging server 172.28.254.254 5 use-vrf default facility local3</pre>	<p>Configures a host to receive syslog messages.</p> <ul style="list-style-type: none"> • The <i>host</i> argument identifies the hostname or the IPv4 or IPv6 address of the syslog server host. • The <i>severity-level</i> argument limits the logging of messages to the syslog server to a specified level. Severity levels range from 0 to 7. See Table 5: System Message Severity Levels, on page 39. • The use vrf <i>vrf-name</i> keyword identifies the default or management values for the VRF name. If a specific VRF is not identified, management is the default. <p>The show running command output can display or not display the VRF based on the following configuration scenarios:</p> <ul style="list-style-type: none"> • You have not configured any VRF and the system takes the management VRF as the default. Then this VRF is not displayed in the output. • You have configured management VRF. Then this VRF is not displayed in the output as the system identifies it as the default. • You have configured any other VRF. Then this VRF is displayed in the output. <p>Note The current Cisco Fabric Services (CFS) distribution does not support VRF. If CFS distribution is enabled, the logging server configured with the default VRF is distributed as the management VRF.</p> <ul style="list-style-type: none"> • The <i>facility</i> argument names the syslog facility type. The default outgoing facility is local7. <p>The facilities are listed in the command reference for the Cisco Nexus Series software that you are using.</p> <p>Note Debugging is a CLI facility but the debug syslogs are not sent to the server.</p>

	Command or Action	Purpose
Step 3	(Optional) no logging server <i>host</i> Example: switch(config)# no logging server 172.28.254.254 5	Removes the logging server for the specified host.
Step 4	(Optional) show logging server Example: switch# show logging server	Displays the syslog server configuration.
Step 5	(Optional) copy running-config startup-config Example: switch(config)# copy running-config startup-config	Saves the change persistently through reboots and restarts by copying the running configuration to the startup configuration.

Example

The following examples show how to configure a syslog server:

```
switch# configure terminal
switch(config)# logging server 172.28.254.254 5
use-vrf default facility local3
```

```
switch# configure terminal
switch(config)# logging server 172.28.254.254 5 use-vrf management facility local3
```

Configuring syslog on a UNIX or Linux System

You can configure a syslog server on a UNIX or Linux system by adding the following line to the `/etc/syslog.conf` file:

```
facility.level <five tab characters> action
```

The following table describes the syslog fields that you can configure.

Table 7: syslog Fields in syslog.conf

Field	Description
Facility	Creator of the message, which can be auth, authpriv, cron, daemon, kern, lpr, mail, mark, news, syslog, user, local0 through local7, or an asterisk (*) for all. These facility designators allow you to control the destination of messages based on their origin. Note Check your configuration before using a local facility.
Level	Minimum severity level at which messages are logged, which can be debug, info, notice, warning, err, crit, alert, emerg, or an asterisk (*) for all. You can use none to disable a facility.
Action	Destination for messages, which can be a filename, a hostname preceded by the at sign (@), or a comma-separated list of users or an asterisk (*) for all logged-in users.

SUMMARY STEPS

1. Log debug messages with the local7 facility in the file /var/log/myfile.log by adding the following line to the /etc/syslog.conf file:
2. Create the log file by entering these commands at the shell prompt:
3. Make sure that the system message logging daemon reads the new changes by checking myfile.log after entering this command:

DETAILED STEPS

Step 1 Log debug messages with the local7 facility in the file /var/log/myfile.log by adding the following line to the /etc/syslog.conf file:

```
debug.local7                /var/log/myfile.log
```

Step 2 Create the log file by entering these commands at the shell prompt:

```
$ touch /var/log/myfile.log
$ chmod 666 /var/log/myfile.log
```

Step 3 Make sure that the system message logging daemon reads the new changes by checking myfile.log after entering this command:

```
$ kill -HUP ~cat /etc/syslog.pid~
```

Configuring syslog Server Configuration Distribution

You can distribute the syslog server configuration to other switches in the network by using the Cisco Fabric Services (CFS) infrastructure.

After you enable syslog server configuration distribution, you can modify the syslog server configuration and view the pending changes before committing the configuration for distribution. As long as distribution is enabled, the switch maintains pending changes to the syslog server configuration.



Note If the switch is restarted, the syslog server configuration changes that are kept in volatile memory might get lost.

Before you begin

You must have configured one or more syslog servers.

SUMMARY STEPS

1. switch# **configure terminal**
2. switch(config)# **logging distribute**
3. switch(config)# **logging commit**

4. switch(config)# **logging abort**
5. (Optional) switch(config)# **no logging distribute**
6. (Optional) switch# **show logging pending**
7. (Optional) switch# **show logging pending-diff**
8. (Optional) switch# **copy running-config startup-config**

DETAILED STEPS

	Command or Action	Purpose
Step 1	switch# configure terminal	Enters global configuration mode.
Step 2	switch(config)# logging distribute	Enables distribution of the syslog server configuration to network switches using the CFS infrastructure. By default, distribution is disabled.
Step 3	switch(config)# logging commit	Commits the pending changes to the syslog server configuration for distribution to the switches in the fabric.
Step 4	switch(config)# logging abort	Cancels the pending changes to the syslog server configuration.
Step 5	(Optional) switch(config)# no logging distribute	Disables the distribution of the syslog server configuration to network switches using the CFS infrastructure. You cannot disable distribution when configuration changes are pending. See the logging commit and logging abort commands. By default, distribution is disabled.
Step 6	(Optional) switch# show logging pending	Displays the pending changes to the syslog server configuration.
Step 7	(Optional) switch# show logging pending-diff	Displays the differences from the current syslog server configuration to the pending changes of the syslog server configuration.
Step 8	(Optional) switch# copy running-config startup-config	Copies the running configuration to the startup configuration.

Displaying and Clearing Log Files

You can display or clear messages in the log file and the NVRAM.

SUMMARY STEPS

1. switch# **show logging last** *number-lines*
2. switch# **show logging logfile** [**start-time** *yyyy mmm dd hh:mm:ss*] [**end-time** *yyyy mmm dd hh:mm:ss*]
3. switch# **show logging nvram** [**last** *number-lines*]
4. switch# **clear logging logfile**
5. switch# **clear logging nvram**

DETAILED STEPS

	Command or Action	Purpose
Step 1	switch# show logging last <i>number-lines</i>	Displays the last number of lines in the logging file. You can specify from 1 to 9999 for the last number of lines.
Step 2	switch# show logging logfile [start-time <i>yyyy mmm dd hh:mm:ss</i>] [end-time <i>yyyy mmm dd hh:mm:ss</i>]	Displays the messages in the log file that have a time stamp within the span entered. If you do not enter an end time, the current time is used. You enter three characters for the month time field and digits for the year and day time fields.
Step 3	switch# show logging nvram [last <i>number-lines</i>]	Displays the messages in the NVRAM. To limit the number of lines displayed, you can enter the last number of lines to display. You can specify from 1 to 100 for the last number of lines.
Step 4	switch# clear logging logfile	Clears the contents of the log file.
Step 5	switch# clear logging nvram	Clears the logged messages in NVRAM.

Example

The following example shows how to display messages in a log file:

```
switch# show logging last 40
switch# show logging logfile start-time 2007 nov 1 15:10:0
switch# show logging nvram last 10
```

The following example shows how to clear messages in a log file:

```
switch# clear logging logfile
switch# clear logging nvram
```

Configuring DOM Logging

Enabling DOM Logging

SUMMARY STEPS

1. switch# **configure terminal**
2. switch(config)# **system ethernet dom polling**

DETAILED STEPS

	Command or Action	Purpose
Step 1	switch# configure terminal	Enters global configuration mode.

	Command or Action	Purpose
Step 2	switch(config)# system ethernet dom polling	Enables transceiver digital optical monitoring periodic polling.

Example

The following example shows how to enable DOM logging.

```
switch# configure terminal
switch(config)# system ethernet dom polling
```

Disabling DOM Logging

SUMMARY STEPS

1. switch# **configure terminal**
2. switch(config)# **no system ethernet dom polling**

DETAILED STEPS

	Command or Action	Purpose
Step 1	switch# configure terminal	Enters global configuration mode.
Step 2	switch(config)# no system ethernet dom polling	Disables transceiver digital optical monitoring periodic polling.

Example

The following example shows how to disable DOM logging.

```
switch# configure terminal
switch(config)# no system ethernet dom polling
```

Verifying the DOM Logging Configuration

Command	Purpose
show system ethernet dom polling status	Displays the transceiver digital optical monitoring periodic polling status.

Verifying the System Message Logging Configuration

Use these commands to verify system message logging configuration information:

Command	Purpose
show logging console	Displays the console logging configuration.
show logging info	Displays the logging configuration.
show logging ip access-list cache	Displays the IP access list cache.
show logging ip access-list cache detail	Displays detailed information about the IP access list cache.
show logging ip access-list status	Displays the status of the IP access list cache.
show logging last <i>number-lines</i>	Displays the last number of lines of the log file.
show logging level [<i>facility</i>]	Displays the facility logging severity level configuration.
show logging logfile [start-time <i>yyyy mmm dd hh:mm:ss</i>] [end-time <i>yyyy mmm dd hh:mm:ss</i>]	Displays the messages in the log file.
show logging module	Displays the module logging configuration.
show logging monitor	Displays the monitor logging configuration.
show logging nvram [last <i>number-lines</i>]	Displays the messages in the NVRAM log.
show logging pending	Displays the syslog server pending distribution configuration.
show logging pending-diff	Displays the syslog server pending distribution configuration differences.
show logging server	Displays the syslog server configuration.
show logging session	Displays the logging session status.
show logging status	Displays the logging status.
show logging timestamp	Displays the logging time-stamp units configuration.

Repeated System Logging Messages

System processes generate logging messages. Depending on the filters used to control which severity levels are generated, a large number of messages can be produced with many of them being repeated.

To make it easier to develop scripts to manage the volume of logging messages, and to eliminate repeated messages from “flooding” the output of the **show logging log** command, the following method of logging repeated messages is used.

In the old method, when the same message was repeated, the default was to state the number of times it reoccurred in the message:

```
2019 Mar 11 13:42:44 Cisco-customer %PTP-2-PTP_INCORRECT_PACKET_ON_SLAVE:
Incorrect delay response packet received on slave interface Eth1/48 by
2c:5a:0f:ff:fe:51:e9:9f. Source Port Identity is 08:00:11:ff:fe:22:3e:4e. Requesting Port
```

```
Identity is 00:1c:73:ff:ff:ee:f6:e5
```

```
2019 Mar 11 13:43:15 Cisco-customer last message repeated 242 times
```

The new method simply appends the repeat count to the end of the repeated message:

```
2019 Mar 11 13:42:44 Cisco-customer %PTP-2-PTP_INCORRECT_PACKET_ON_SLAVE:  
Incorrect delay response packet received on slave interface Eth1/48 by  
2c:5a:0f:ff:fe:51:e9:9f. Source Port Identity is 08:00:11:ff:fe:22:3e:4e. Requesting Port  
Identity is 00:1c:73:ff:ff:ee:f6:e5
```

```
2019 Mar 11 13:43:15 Cisco-customer %PTP-2-PTP_INCORRECT_PACKET_ON_SLAVE:  
Incorrect delay response packet received on slave interface Eth1/48 by  
2c:5a:0f:ff:fe:51:e9:9f. Source Port Identity is 08:00:11:ff:fe:22:3e:4e. Requesting Port  
Identity is 00:1c:73:ff:ff:ee:f6:e5 (message repeated 242 times)
```



CHAPTER 6

Configuring Smart Call Home

This chapter contains the following sections:

- [Information About Smart Call Home, on page 57](#)
- [Guidelines and Limitations for Smart Call Home, on page 65](#)
- [Prerequisites for Smart Call Home, on page 65](#)
- [Default Call Home Settings, on page 65](#)
- [Configuring Smart Call Home, on page 66](#)
- [Verifying the Smart Call Home Configuration, on page 78](#)
- [Sample Syslog Alert Notification in Full-Text Format, on page 78](#)
- [Sample Syslog Alert Notification in XML Format, on page 79](#)

Information About Smart Call Home

Smart Call Home provides e-mail-based notification of critical system events. Cisco Nexus Series switches provide a range of message formats for optimal compatibility with pager services, standard e-mail, or XML-based automated parsing applications. You can use this feature to page a network support engineer, e-mail a Network Operations Center, or use Cisco Smart Call Home services to automatically generate a case with the Technical Assistance Center (TAC).

If you have a service contract directly with Cisco, you can register your devices for the Smart Call Home service. Smart Call Home provides fast resolution of system problems by analyzing Smart Call Home messages sent from your devices and providing background information and recommendations. For issues that can be identified as known, particularly GOLD diagnostics failures, Automatic Service Requests will be generated by the Cisco TAC.

Smart Call Home offers the following features:

- Continuous device health monitoring and real-time diagnostic alerts.
- Analysis of Smart Call Home messages from your device and, where appropriate, Automatic Service Request generation, routed to the appropriate TAC team, including detailed diagnostic information to speed problem resolution.
- Secure message transport directly from your device or through a downloadable Transport Gateway (TG) aggregation point. You can use a TG aggregation point in cases that require support for multiple devices or in cases where security requirements mandate that your devices may not be connected directly to the Internet.

- Web-based access to Smart Call Home messages and recommendations, inventory and configuration information for all Smart Call Home devices, and field notices, security advisories, and end-of-life information.

Smart Call Home Overview

You can use Smart Call Home to notify an external entity when an important event occurs on your device. Smart Call Home delivers alerts to multiple recipients that you configure in destination profiles.

Smart Call Home includes a fixed set of predefined alerts on your switch. These alerts are grouped into alert groups and CLI commands that are assigned to execute when an alert in an alert group occurs. The switch includes the command output in the transmitted Smart Call Home message.

The Smart Call Home feature offers the following:

- Automatic execution and attachment of relevant CLI command output.
- Multiple message format options such as the following:
 - Short Text—Text that is suitable for pagers or printed reports.
 - Full Text—Fully formatted message information that is suitable for human reading.
 - XML—Matching readable format that uses the Extensible Markup Language (XML) and the Adaptive Messaging Language (AML) XML schema definition (XSD). The XML format enables communication with the Cisco TAC.
- Multiple concurrent message destinations. You can configure up to 50 e-mail destination addresses for each destination profile.

Smart Call Home Destination Profiles

A Smart Call Home destination profile includes the following information:

- One or more alert groups—The group of alerts that trigger a specific Smart Call Home message if the alert occurs.
- One or more e-mail destinations—The list of recipients for the Smart Call Home messages that are generated by alert groups assigned to this destination profile.
- Message format—The format for the Smart Call Home message (short text, full text, or XML).
- Message severity level—The Smart Call Home severity level that the alert must meet before the switch generates a Smart Call Home message to all e-mail addresses in the destination profile. The switch does not generate an alert if the Smart Call Home severity level of the alert is lower than the message severity level set for the destination profile.

You can also configure a destination profile to allow periodic inventory update messages by using the inventory alert group that will send out periodic messages daily, weekly, or monthly.

Cisco Nexus switches support the following predefined destination profiles:

- CiscoTAC-1—Supports the Cisco-TAC alert group in XML message format.
- full-text-destination—Supports the full text message format.

- short-text-destination—Supports the short text message format.

Smart Call Home Alert Groups

An alert group is a predefined subset of Smart Call Home alerts that are supported in all Cisco Nexus devices. Alert groups allow you to select the set of Smart Call Home alerts that you want to send to a predefined or custom destination profile. The switch sends Smart Call Home alerts to e-mail destinations in a destination profile only if that Smart Call Home alert belongs to one of the alert groups associated with that destination profile and if the alert has a Smart Call Home message severity at or above the message severity set in the destination profile.

The following table lists the supported alert groups and the default CLI command output included in Smart Call Home messages generated for the alert group.

Table 8: Alert Groups and Executed Commands

Alert Group	Description	Executed Commands
Cisco-TAC	All critical alerts from the other alert groups destined for Smart Call Home.	Execute commands based on the alert group that originates the alert.
Diagnostic	Events generated by diagnostics.	show diagnostic result module all detail show moduleshow version show tech-support platform callhome
Supervisor hardware	Events related to supervisor modules.	show diagnostic result module all detail show moduleshow version show tech-support platform callhome
Linecard hardware	Events related to standard or intelligent switching modules.	show diagnostic result module all detail show moduleshow version show tech-support platform callhome
Configuration	Periodic events related to configuration.	show version show module show running-config all show startup-config
System	Events generated by a failure of a software system that is critical to unit operation.	show system redundancy status show tech-support
Environmental	Events related to power, fan, and environment-sensing elements such as temperature alarms.	show environment show logging last 1000 show module show version show tech-support platform callhome

Alert Group	Description	Executed Commands
Inventory	Inventory status that is provided whenever a unit is cold booted, or when FRUs are inserted or removed. This alert is considered a noncritical event, and the information is used for status and entitlement.	show module show version show license usage show inventory show sprom all show system uptime

Smart Call Home maps the syslog severity level to the corresponding Smart Call Home severity level for syslog port group messages.

You can customize predefined alert groups to execute additional **show** commands when specific events occur and send that **show** output with the Smart Call Home message.

You can add **show** commands only to full text and XML destination profiles. Short text destination profiles do not support additional **show** commands because they only allow 128 bytes of text.

Smart Call Home Message Levels

Smart Call Home allows you to filter messages based on their level of urgency. You can associate each destination profile (predefined and user defined) with a Smart Call Home message level threshold. The switch does not generate any Smart Call Home messages with a value lower than this threshold for the destination profile. The Smart Call Home message level ranges from 0 (lowest level of urgency) to 9 (highest level of urgency), and the default is 0 (the switch sends all messages).

Smart Call Home messages that are sent for syslog alert groups have the syslog severity level mapped to the Smart Call Home message level.



Note Smart Call Home does not change the syslog message level in the message text.

The following table shows each Smart Call Home message level keyword and the corresponding syslog level for the syslog port alert group.

Table 9: Severity and Syslog Level Mapping

Smart Call Home Level	Keyword	Syslog Level	Description
9	Catastrophic	N/A	Network-wide catastrophic failure.
8	Disaster	N/A	Significant network impact.
7	Fatal	Emergency (0)	System is unusable.
6	Critical	Alert (1)	Critical conditions that indicate that immediate attention is needed.
5	Major	Critical (2)	Major conditions.

Smart Call Home Level	Keyword	Syslog Level	Description
4	Minor	Error (3)	Minor conditions.
3	Warning	Warning (4)	Warning conditions.
2	Notification	Notice (5)	Basic notification and informational messages.
1	Normal	Information (6)	Normal event signifying return to normal state.
0	Debugging	Debug (7)	Debugging messages.

Call Home Message Formats

Call Home supports the following message formats:

- Short text message format
- Common fields for all full text and XML messages
- Inserted fields for a reactive or proactive event message
- Inserted fields for an inventory event message
- Inserted fields for a user-generated test message

The following table describes the short text formatting option for all message types.

Table 10: Short Text Message Format

Data Item	Description
Device identification	Configured device name
Date/time stamp	Time stamp of the triggering event
Error isolation message	Plain English description of triggering event
Alarm urgency level	Error level such as that applied to a system message

The following table describes the common event message format for full text or XML.

Table 11: Common Fields for All Full Text and XML Messages

Data Item (Plain Text and XML)	Description (Plain Text and XML)	XML Tag (XML Only)
Time stamp	Date and time stamp of event in ISO time notation: <i>YYYY-MM-DD HH:MM:SS</i> <i>GMT+HH:MM</i>	/aml/header/time

Data Item (Plain Text and XML)	Description (Plain Text and XML)	XML Tag (XML Only)
Message name	Name of message. Specific event names are listed in the preceding table.	/aml/header/name
Message type	Name of message type, such as reactive or proactive.	/aml/header/type
Message group	Name of alert group, such as syslog.	/aml/header/group
Severity level	Severity level of message.	/aml/header/level
Source ID	Product type for routing.	/aml/header/source
Device ID	<p>Unique device identifier (UDI) for the end device that generated the message. This field should be empty if the message is nonspecific to a device. The format is <i>type@Sid@serial</i>:</p> <ul style="list-style-type: none"> • <i>type</i> is the product model number from backplane IDPROM. • <i>@</i> is a separator character. • <i>Sid</i> is C, identifying the serial ID as a chassis serial number. • <i>serial</i> is the number identified by the Sid field. <p>An example is WS-C6509@C@12345678</p>	/aml/ header/deviceID
Customer ID	Optional user-configurable field used for contract information or other ID by any support service.	/aml/ header/customerID
Contract ID	Optional user-configurable field used for contract information or other ID by any support service.	/aml/ header /contractID
Site ID	Optional user-configurable field used for Cisco-supplied site ID or other data meaningful to alternate support service.	/aml/ header/siteID

Data Item (Plain Text and XML)	Description (Plain Text and XML)	XML Tag (XML Only)
Server ID	<p>If the message is generated from the device, this is the unique device identifier (UDI) of the device.</p> <p>The format is <i>type@Sid@serial</i>:</p> <ul style="list-style-type: none"> • <i>type</i> is the product model number from backplane IDPROM. • <i>@</i> is a separator character. • <i>Sid</i> is C, identifying the serial ID as a chassis serial number. • <i>serial</i> is the number identified by the Sid field. <p>An example is WS-C6509@C@12345678</p>	/aml/header/serverID
Message description	Short text that describes the error.	/aml/body/msgDesc
Device name	Node that experienced the event (hostname of the device).	/aml/body/sysName
Contact name	Name of person to contact for issues associated with the node that experienced the event.	/aml/body/sysContact
Contact e-mail	E-mail address of person identified as the contact for this unit.	/aml/body/sysContactEmail
Contact phone number	Phone number of the person identified as the contact for this unit.	/aml/body/sysContactPhoneNumber
Street address	Optional field that contains the street address for RMA part shipments associated with this unit.	/aml/body/sysStreetAddress
Model name	Model name of the device (the specific model as part of a product family name).	/aml/body/chassis/name
Serial number	Chassis serial number of the unit.	/aml/body/chassis/serialNo
Chassis part number	Top assembly number of the chassis.	/aml/body/chassis/partNo
Fields specific to a particular alert group message are inserted here.		
The following fields may be repeated if multiple CLI commands are executed for this alert group.		

Data Item (Plain Text and XML)	Description (Plain Text and XML)	XML Tag (XML Only)
Command output name	Exact name of the issued CLI command.	/aml/attachments/attachment/name
Attachment type	Specific command output.	/aml/attachments/attachment/type
MIME type	Either plain text or encoding type.	/aml/attachments/attachment/mime
Command output text	Output of command automatically executed.	/aml/attachments/attachment/atdata

The following table describes the reactive event message format for full text or XML.

Table 12: Inserted Fields for a Reactive or Proactive Event Message

Data Item (Plain Text and XML)	Description (Plain Text and XML)	XML Tag (XML Only)
Chassis hardware version	Hardware version of chassis.	/aml/body/chassis/hwVersion
Supervisor module software version	Top-level software version.	/aml/body/chassis/swVersion
Affected FRU name	Name of the affected FRU that is generating the event message.	/aml/body/fru/name
Affected FRU serial number	Serial number of the affected FRU.	/aml/body/fru/serialNo
Affected FRU part number	Part number of the affected FRU.	/aml/body/fru/partNo
FRU slot	Slot number of the FRU that is generating the event message.	/aml/body/fru/slot
FRU hardware version	Hardware version of the affected FRU.	/aml/body/fru/hwVersion
FRU software version	Software version(s) that is running on the affected FRU.	/aml/body/fru/swVersion

The following table describes the inventory event message format for full text or XML.

Table 13: Inserted Fields for an Inventory Event Message

Data Item (Plain Text and XML)	Description (Plain Text and XML)	XML Tag (XML Only)
Chassis hardware version	Hardware version of the chassis.	/aml/body/chassis/hwVersion
Supervisor module software version	Top-level software version.	/aml/body/chassis/swVersion
FRU name	Name of the affected FRU that is generating the event message.	/aml/body/fru/name
FRU s/n	Serial number of the FRU.	/aml/body/fru/serialNo
FRU part number	Part number of the FRU.	/aml/body/fru/partNo

Data Item (Plain Text and XML)	Description (Plain Text and XML)	XML Tag (XML Only)
FRU slot	Slot number of the FRU.	/aml/body/fru/slot
FRU hardware version	Hardware version of the FRU.	/aml/body/fru/hwVersion
FRU software version	Software version(s) that is running on the FRU.	/aml/body/fru/swVersion

The following table describes the user-generated test message format for full text or XML.

Table 14: Inserted Fields for a User-Generated Test Message

Data Item (Plain Text and XML)	Description (Plain Text and XML)	XML Tag (XML Only)
Process ID	Unique process ID.	/aml/body/process/id
Process state	State of process (for example, running or halted).	/aml/body/process/processState
Process exception	Exception or reason code.	/aml/body/process/exception

Guidelines and Limitations for Smart Call Home

- If there is no IP connectivity, or if the interface in the virtual routing and forwarding (VRF) instance to the profile destination is down, the switch cannot send Smart Call Home messages.
- Operates with any SMTP e-mail server.

Prerequisites for Smart Call Home

- You must have e-mail server connectivity.
- You must have access to contact name (SNMP server contact), phone, and street address information.
- You must have IP connectivity between the switch and the e-mail server.
- You must have an active service contract for the device that you are configuring.

Default Call Home Settings

Table 15: Default Call Home Parameters

Parameters	Default
Destination message size for a message sent in full text format	4000000
Destination message size for a message sent in XML format	4000000

Parameters	Default
Destination message size for a message sent in short text format	4000
SMTP server port number if no port is specified	25
Alert group association with profile	All for full-text-destination and short-text-destination profiles. The cisco-tac alert group for the CiscoTAC-1 destination profile.
Format type	XML
Call Home message level	0 (zero)

Configuring Smart Call Home

Registering for Smart Call Home

Before you begin

- Know the sMARTnet contract number for your switch
- Know your e-mail address
- Know your Cisco.com ID

SUMMARY STEPS

1. In a browser, navigate to the Smart Call Home web page:
2. Under **Getting Started**, follow the directions to register Smart Call Home.

DETAILED STEPS

Step 1 In a browser, navigate to the Smart Call Home web page:

<http://www.cisco.com/go/smartcall/>

Step 2 Under **Getting Started**, follow the directions to register Smart Call Home.

What to do next

Configure contact information.

Configuring Contact Information

You must configure the e-mail, phone, and street address information for Smart Call Home. You can optionally configure the contract ID, customer ID, site ID, and switch priority information.

SUMMARY STEPS

1. switch# **configure terminal**
2. switch(config)# **snmp-server contact** *sys-contact*
3. switch(config)# **callhome**
4. switch(config-callhome)# **email-contact** *email-address*
5. switch(config-callhome)# **phone-contact** *international-phone-number*
6. switch(config-callhome)# **streetaddress** *address*
7. (Optional) switch(config-callhome)# **contract-id** *contract-number*
8. (Optional) switch(config-callhome)# **customer-id** *customer-number*
9. (Optional) switch(config-callhome)# **site-id** *site-number*
10. (Optional) switch(config-callhome)# **switch-priority** *number*
11. (Optional) switch# **show callhome**
12. (Optional) switch(config)# **copy running-config startup-config**

DETAILED STEPS

	Command or Action	Purpose
Step 1	switch# configure terminal	Enters global configuration mode.
Step 2	switch(config)# snmp-server contact <i>sys-contact</i>	Configures the SNMP sysContact.
Step 3	switch(config)# callhome	Enters Smart Call Home configuration mode.
Step 4	switch(config-callhome)# email-contact <i>email-address</i>	<p>Configures the e-mail address for the primary person responsible for the switch.</p> <p>The <i>email-address</i> can be up to 255 alphanumeric characters in an e-mail address format.</p> <p>Note You can use any valid e-mail address. The address cannot contain spaces.</p>
Step 5	switch(config-callhome)# phone-contact <i>international-phone-number</i>	<p>Configures the phone number in international phone number format for the primary person responsible for the device. The <i>international-phone-number</i> can be up to 17 alphanumeric characters and must be in international phone number format.</p> <p>Note The phone number cannot contain spaces. Use the plus (+) prefix before the number.</p>
Step 6	switch(config-callhome)# streetaddress <i>address</i>	Configures the street address for the primary person responsible for the switch.

	Command or Action	Purpose
		The <i>address</i> can be up to 255 alphanumeric characters. Spaces are accepted.
Step 7	(Optional) switch(config-callhome)# contract-id <i>contract-number</i>	Configures the contract number for this switch from the service agreement. The <i>contract-number</i> can be up to 255 alphanumeric characters.
Step 8	(Optional) switch(config-callhome)# customer-id <i>customer-number</i>	Configures the customer number for this switch from the service agreement. The <i>customer-number</i> can be up to 255 alphanumeric characters.
Step 9	(Optional) switch(config-callhome)# site-id <i>site-number</i>	Configures the site number for this switch. The <i>site-number</i> can be up to 255 alphanumeric characters in free format.
Step 10	(Optional) switch(config-callhome)# switch-priority <i>number</i>	Configures the switch priority for this switch. The range is from 0 to 7, with 0 being the highest priority and 7 the lowest. The default is 7. Note Switch priority is used by the operations personnel or TAC support personnel to decide which Call Home message should be responded to first. You can prioritize Call Home alerts of the same severity from each switch.
Step 11	(Optional) switch# show callhome	Displays a summary of the Smart Call Home configuration.
Step 12	(Optional) switch(config)# copy running-config startup-config	Saves the change persistently through reboots and restarts by copying the running configuration to the startup configuration.

Example

The following example shows how to configure the contact information for Call Home:

```
switch# configuration terminal
switch(config)# snmp-server contact personname@companyname.com
switch(config)# callhome
switch(config-callhome)# email-contact personname@companyname.com
switch(config-callhome)# phone-contact +1-800-123-4567
switch(config-callhome)# street-address 123 Anystreet St., Anycity, Anywhere
```

What to do next

Create a destination profile.

Creating a Destination Profile

You must create a user-defined destination profile and configure the message format for that new destination profile.

SUMMARY STEPS

1. switch# **configure terminal**
2. switch(config)# **callhome**
3. switch(config-callhome)# **destination-profile** {ciscoTAC-1 {**alert-group** *group* | **email-addr** *address* | **http** *URL* | **transport-method** {**email** | **http**}} | *profilename* {**alert-group** *group* | **email-addr** *address* | **format** {**XML** | **full-txt** | **short-txt**} | **http** *URL* | **message-level** *level* | **message-size** *size* | **transport-method** {**email** | **http**}} | **full-txt-destination** {**alert-group** *group* | **email-addr** *address* | **http** *URL* | **message-level** *level* | **message-size** *size* | **transport-method** {**email** | **http**}} | **short-txt-destination** {**alert-group** *group* | **email-addr** *address* | **http** *URL* | **message-level** *level* | **message-size** *size* | **transport-method** {**email** | **http**}}}
4. (Optional) switch# **show callhome destination-profile** [*profile name*]
5. (Optional) switch(config)# **copy running-config startup-config**

DETAILED STEPS

	Command or Action	Purpose
Step 1	switch# configure terminal	Enters global configuration mode.
Step 2	switch(config)# callhome	Enters Smart Call Home configuration mode.
Step 3	switch(config-callhome)# destination-profile {ciscoTAC-1 { alert-group <i>group</i> email-addr <i>address</i> http <i>URL</i> transport-method { email http }} <i>profilename</i> { alert-group <i>group</i> email-addr <i>address</i> format { XML full-txt short-txt } http <i>URL</i> message-level <i>level</i> message-size <i>size</i> transport-method { email http }} full-txt-destination { alert-group <i>group</i> email-addr <i>address</i> http <i>URL</i> message-level <i>level</i> message-size <i>size</i> transport-method { email http }} short-txt-destination { alert-group <i>group</i> email-addr <i>address</i> http <i>URL</i> message-level <i>level</i> message-size <i>size</i> transport-method { email http }}}	Creates a new destination profile and sets the message format for the profile. The profile-name can be any alphanumeric string up to 31 characters. For further details about this command, see the command reference for your platform.
Step 4	(Optional) switch# show callhome destination-profile [<i>profile name</i>]	Displays information about one or more destination profiles.
Step 5	(Optional) switch(config)# copy running-config startup-config	Saves the change persistently through reboots and restarts by copying the running configuration to the startup configuration.

Example

The following example shows how to create a destination profile for Smart Call Home:

```
switch# configuration terminal
switch(config)# callhome
switch(config-callhome)# destination-profile Noc101 format full-text
```

Modifying a Destination Profile

You can modify the following attributes for a predefined or user-defined destination profile:

- Destination address—The actual address, pertinent to the transport mechanism, to which the alert should be sent.
- Message formatting—The message format used for sending the alert (full text, short text, or XML).
- Message level—The Call Home message severity level for this destination profile.
- Message size—The allowed length of a Call Home message sent to the e-mail addresses in this destination profile.



Note You cannot modify or delete the CiscoTAC-1 destination profile.

SUMMARY STEPS

1. switch# **configure terminal**
2. switch(config)# **callhome**
3. switch(config-callhome)# **destination-profile** {*name* | **full-txt-destination** | **short-txt-destination**} **email-addr** *address*
4. **destination-profile** {*name* | **full-txt-destination** | **short-txt-destination**} **message-level** *number*
5. switch(config-callhome)# **destination-profile** {*name* | **full-txt-destination** | **short-txt-destination**} **message-size** *number*
6. (Optional) switch# **show callhome destination-profile** [**profile** *name*]
7. (Optional) switch(config)# **copy running-config startup-config**

DETAILED STEPS

	Command or Action	Purpose
Step 1	switch# configure terminal	Enters global configuration mode.
Step 2	switch(config)# callhome	Enters Smart Call Home configuration mode.
Step 3	switch(config-callhome)# destination-profile { <i>name</i> full-txt-destination short-txt-destination } email-addr <i>address</i>	Configures an e-mail address for a user-defined or predefined destination profile. You can configure up to 50 e-mail addresses in a destination profile.
Step 4	destination-profile { <i>name</i> full-txt-destination short-txt-destination } message-level <i>number</i>	Configures the Smart Call Home message severity level for this destination profile. The switch sends only alerts that have a matching or higher Smart Call Home severity level to destinations in this profile. The range for the <i>number</i> is from 0 to 9, where 9 is the highest severity level.

	Command or Action	Purpose
Step 5	switch(config-callhome)# destination-profile { <i>name</i> full-txt-destination short-txt-destination } message-size <i>number</i>	Configures the maximum message size for this destination profile. The range is from 0 to 5000000 for full-txt-destination and the default is 2500000. The range is from 0 to 100000 for short-txt-destination and the default is 4000. The value is 5000000 for CiscoTAC-1, which is not changeable.
Step 6	(Optional) switch# show callhome destination-profile [profile <i>name</i>]	Displays information about one or more destination profiles.
Step 7	(Optional) switch(config)# copy running-config startup-config	Saves the change persistently through reboots and restarts by copying the running configuration to the startup configuration.

Example

The following example shows how to modify a destination profile for Smart Call Home:

```
switch# configuration terminal
switch(config)# callhome
switch(config-callhome)# destination-profile full-text-destination email-addr
person@example.com
switch(config-callhome)# destination-profile full-text-destination message-level 5
switch(config-callhome)# destination-profile full-text-destination message-size 10000
switch(config-callhome)#
```

What to do next

Associate an alert group with a destination profile.

Associating an Alert Group with a Destination Profile

SUMMARY STEPS

1. switch# **configure terminal**
2. switch(config)# **callhome**
3. switch(config-callhome)# **destination-profile** *name* **alert-group** {**All** | **Cisco-TAC** | **Configuration** | **Diagnostic** | **Environmental** | **Inventory** | **License** | **Linecard-Hardware** | **Supervisor-Hardware** | **Syslog-group-port** | **System** | **Test**}
4. (Optional) switch# **show callhome destination-profile** [**profile** *name*]
5. (Optional) switch(config)# **copy running-config startup-config**

DETAILED STEPS

	Command or Action	Purpose
Step 1	switch# configure terminal	Enters global configuration mode.
Step 2	switch(config)# callhome	Enters Smart Call Home configuration mode.

	Command or Action	Purpose
Step 3	switch(config-callhome)# destination-profile <i>name</i> alert-group { All Cisco-TAC Configuration Diagnostic Environmental Inventory License Linecard-Hardware Supervisor-Hardware Syslog-group-port System Test }	Associates an alert group with this destination profile. Use the All keyword to associate all alert groups with the destination profile.
Step 4	(Optional) switch# show callhome destination-profile [<i>profile name</i>]	Displays information about one or more destination profiles.
Step 5	(Optional) switch(config)# copy running-config startup-config	Saves the change persistently through reboots and restarts by copying the running configuration to the startup configuration.

Example

The following example shows how to associate all alert groups with the destination profile Noc101:

```
switch# configuration terminal
switch(config)# callhome
switch(config-callhome)# destination-profile Noc101 alert-group All
switch(config-callhome)#
```

What to do next

Optionally, you can add **show** commands to an alert group and configure the SMTP e-mail server.

Adding Show Commands to an Alert Group

You can assign a maximum of five user-defined **show** commands to an alert group.

SUMMARY STEPS

1. switch# **configure terminal**
2. switch(config)# **callhome**
3. switch(config-callhome)# **alert-group** {**Configuration** | **Diagnostic** | **Environmental** | **Inventory** | **License** | **Linecard-Hardware** | **Supervisor-Hardware** | **Syslog-group-port** | **System** | **Test**}
user-def-cmd *show-cmd*
4. (Optional) switch# **show callhome user-def-cmds**
5. (Optional) switch(config)# **copy running-config startup-config**

DETAILED STEPS

	Command or Action	Purpose
Step 1	switch# configure terminal	Enters global configuration mode.
Step 2	switch(config)# callhome	Enters Smart Call Home configuration mode.

	Command or Action	Purpose
Step 3	switch(config-callhome)# alert-group { Configuration Diagnostic Environmental Inventory License Linecard-Hardware Supervisor-Hardware Syslog-group-port System Test } user-def-cmd <i>show-cmd</i>	Adds the show command output to any Call Home messages sent for this alert group. Only valid show commands are accepted. Note You cannot add user-defined show commands to the CiscoTAC-1 destination profile.
Step 4	(Optional) switch# show callhome user-def-cmds	Displays information about all user-defined show commands added to alert groups.
Step 5	(Optional) switch(config)# copy running-config startup-config	Saves the change persistently through reboots and restarts by copying the running configuration to the startup configuration.

Example

The following example shows how to add the **show ip routing** command to the Cisco-TAC alert group:

```
switch# configuration terminal
switch(config)# callhome
switch(config-callhome)# alert-group Configuration user-def-cmd show ip routing
switch(config-callhome)#
```

What to do next

Configure Smart Call Home to connect to the SMTP e-mail server.

Configuring E-Mail Server Details

You must configure the SMTP server address for the Smart Call Home functionality to work. You can also configure the from and reply-to e-mail addresses.

SUMMARY STEPS

1. switch# **configure terminal**
2. switch(config)# **callhome**
3. switch(config-callhome)# **transport email smtp-server** *ip-address* [**port number**] [**use-vrf** *vrf-name*]
4. (Optional) switch(config-callhome)# **transport email from** *email-address*
5. (Optional) switch(config-callhome)# **transport email reply-to** *email-address*
6. (Optional) switch# **show callhome transport-email**
7. (Optional) switch(config)# **copy running-config startup-config**

DETAILED STEPS

	Command or Action	Purpose
Step 1	switch# configure terminal	Enters global configuration mode.

	Command or Action	Purpose
Step 2	switch(config)# callhome	Enters Smart Call Home configuration mode.
Step 3	switch(config-callhome)# transport email smtp-server ip-address [port number] [use-vrf vrf-name]	Configures the SMTP server as either the domain name server (DNS) name, IPv4 address, or IPv6 address. The <i>number</i> range is from 1 to 65535. The default port number is 25. Optionally, you can configure the VRF instance to use when communicating with this SMTP server.
Step 4	(Optional) switch(config-callhome)# transport email from email-address	Configures the e-mail from field for Smart Call Home messages.
Step 5	(Optional) switch(config-callhome)# transport email reply-to email-address	Configures the e-mail reply-to field for Smart Call Home messages.
Step 6	(Optional) switch# show callhome transport-email	Displays information about the e-mail configuration for Smart Call Home.
Step 7	(Optional) switch(config)# copy running-config startup-config	Saves the change persistently through reboots and restarts by copying the running configuration to the startup configuration.

Example

The following example shows how to configure the e-mail options for Smart Call Home messages:

```
switch# configuration terminal
switch(config)# callhome
switch(config-callhome)# transport email smtp-server 192.0.2.10 use-vrf Red
switch(config-callhome)# transport email from person@example.com
switch(config-callhome)# transport email reply-to person@example.com
switch(config-callhome)#
```

What to do next

Configure periodic inventory notifications.

Configuring Periodic Inventory Notifications

You can configure the switch to periodically send a message with an inventory of all software services currently enabled and running on the device with hardware inventory information. The switch generates two Smart Call Home notifications; periodic configuration messages and periodic inventory messages.

SUMMARY STEPS

1. switch# **configure terminal**
2. switch(config)# **callhome**
3. switch(config-callhome)# **periodic-inventory notification [interval days] [timeofday time]**
4. (Optional) switch# **show callhome**

5. (Optional) switch(config)# copy running-config startup-config

DETAILED STEPS

	Command or Action	Purpose
Step 1	switch# configure terminal	Enters global configuration mode.
Step 2	switch(config)# callhome	Enters Smart Call Home configuration mode.
Step 3	switch(config-callhome)# periodic-inventory notification [interval days] [timeofday time]	Configures periodic inventory messages. The interval days range is from 1 to 30 days. The default is 7 days. The timeofday time is in HH:MM format.
Step 4	(Optional) switch# show callhome	Displays information about Smart Call Home.
Step 5	(Optional) switch(config)# copy running-config startup-config	Saves the change persistently through reboots and restarts by copying the running configuration to the startup configuration.

Example

The following example shows how to configure the periodic inventory messages to generate every 20 days:

```
switch# configuration terminal
switch(config)# callhome
switch(config-callhome)# periodic-inventory notification interval 20
switch(config-callhome)#
```

What to do next

Disable duplicate message throttling.

Disabling Duplicate Message Throttling

You can limit the number of duplicate messages received for the same event. By default, the switch limits the number of duplicate messages received for the same event. If the number of duplicate messages sent exceeds 30 messages within a 2-hour time frame, the switch discards further messages for that alert type.

SUMMARY STEPS

1. switch# **configure terminal**
2. switch(config)# **callhome**
3. switch(config-callhome) # **no duplicate-message throttle**
4. (Optional) switch(config)# **copy running-config startup-config**

DETAILED STEPS

	Command or Action	Purpose
Step 1	switch# configure terminal	Enters global configuration mode.
Step 2	switch(config)# callhome	Enters Smart Call Home configuration mode.
Step 3	switch(config-callhome) # no duplicate-message throttle	Disables duplicate message throttling for Smart Call Home. Duplicate message throttling is enabled by default.
Step 4	(Optional) switch(config)# copy running-config startup-config	Saves the change persistently through reboots and restarts by copying the running configuration to the startup configuration.

Example

The following example shows how to disable duplicate message throttling:

```
switch# configuration terminal
switch(config)# callhome
switch(config-callhome) # no duplicate-message throttle
switch(config-callhome) #
```

What to do next

Enable Smart Call Home.

Enabling or Disabling Smart Call Home

SUMMARY STEPS

1. switch# **configure terminal**
2. switch(config)# **callhome**
3. switch(config-callhome) # **[no] enable**
4. (Optional) switch(config)# **copy running-config startup-config**

DETAILED STEPS

	Command or Action	Purpose
Step 1	switch# configure terminal	Enters global configuration mode.
Step 2	switch(config)# callhome	Enters Smart Call Home configuration mode.
Step 3	switch(config-callhome) # [no] enable	Enables or disables Smart Call Home. Smart Call Home is disabled by default.
Step 4	(Optional) switch(config)# copy running-config startup-config	Saves the change persistently through reboots and restarts by copying the running configuration to the startup configuration.

Example

The following example shows how to enable Smart Call Home:

```
switch# configuration terminal
switch(config)# callhome
switch(config-callhome)# enable
switch(config-callhome)#
```

What to do next

Optionally, generate a test message.

Testing the Smart Call Home Configuration

Before you begin

Verify that the message level for the destination profile is set to 2 or lower.



Important Smart Call Home testing fails when the message level for the destination profile is set to 3 or higher.

SUMMARY STEPS

1. switch# **configure terminal**
2. switch(config)# **callhome**
3. switch(config-callhome) # **callhome send diagnostic**
4. switch(config-callhome) # **callhome test**
5. (Optional) switch(config)# **copy running-config startup-config**

DETAILED STEPS

	Command or Action	Purpose
Step 1	switch# configure terminal	Enters global configuration mode.
Step 2	switch(config)# callhome	Enters Smart Call Home configuration mode.
Step 3	switch(config-callhome) # callhome send diagnostic	Sends the specified Smart Call Home message to all configured destinations.
Step 4	switch(config-callhome) # callhome test	Sends a test message to all configured destinations.
Step 5	(Optional) switch(config)# copy running-config startup-config	Saves the change persistently through reboots and restarts by copying the running configuration to the startup configuration.

Example

The following example shows how to enable Smart Call Home:

```
switch# configuration terminal
switch(config)# callhome
switch(config-callhome)# callhome send diagnostic
switch(config-callhome)# callhome test
switch(config-callhome)#
```

Verifying the Smart Call Home Configuration

Use one of the following commands to verify the configuration:

Command	Purpose
show callhome	Displays the status for Smart Call Home.
show callhome destination-profile <i>name</i>	Displays one or more Smart Call Home destination profiles.
show callhome pending-diff	Displays the differences between the pending and running Smart Call Home configuration.
show callhome status	Displays the Smart Call Home status.
show callhome transport-email	Displays the e-mail configuration for Smart Call Home.
show callhome user-def-cmds	Displays CLI commands added to any alert groups.
show running-config [callhome callhome-all]	Displays the running configuration for Smart Call Home.
show startup-config callhome	Displays the startup configuration for Smart Call Home.
show tech-support callhome	Displays the technical support output for Smart Call Home.

Sample Syslog Alert Notification in Full-Text Format

This sample shows the full-text format for a syslog port alert-group notification:

```
source:MDS9000
Switch Priority:7
Device Id:WS-C6509@C@FG@07120011
Customer Id:Example.com
Contract Id:123
Site Id:San Jose
Server Id:WS-C6509@C@FG@07120011
Time of Event:2018-02-08T11:10:44
Message Name:SYSLOG_ALERT
Message Type:Syslog
Severity Level:2
System Name:10.76.100.177
Contact Name:User Name
Contact Email:person@example.com
```

```

Contact Phone:+1-408-555-1212
Street Address:#1234 Any Street, Any City, Any State, 12345
Event Description:2018 Feb  8 11:10:44 10.76.100.177 %PORT-5-IF_TRUNK_UP:
%$VLAN 1%$ Interface e2/5, vlan 1 is up
syslog_facility:PORT
start chassis information:
Affected Chassis:WS-C6509
Affected Chassis Serial Number:FG07120011
Affected Chassis Hardware Version:0.104
Affected Chassis Software Version:3.1(1)
Affected Chassis Part No:73-8607-01
end chassis information:

```

Sample Syslog Alert Notification in XML Format

This sample shows the XML format for a syslog port alert-group notification:

```

From: example
Sent: Wednesday, Feb 25, 2018 7:20 AM
To: User (user)
Subject: System Notification From Router - syslog - 2018-02-25 14:19:55
GMT+00:00
<?xml version="1.0" encoding="UTF-8"?>
<soap-env:Envelope xmlns:soap-env="http://www.w3.org/2003/05/soap-envelope">
<soap-env:Header>
<aml-session:Session xmlns:aml-session="http://www.example.com/2004/01/aml-session"
soap-env:mustUnderstand="true" soap-env:role=
"http://www.w3.org/2003/05/soap-envelope/role/next">
<aml-session:To>http://tools.example.com/services/DDCEService</aml-session:To>
<aml-session:Path>
<aml-session:Via>http://www.example.com/appliance/uri</aml-session:Via>
</aml-session:Path>
<aml-session:From>http://www.example.com/appliance/uri</aml-session:From>
<aml-session:MessageId>M2:69000101:C9D9E20B</aml-session:MessageId>
</aml-session:Session>
</soap-env:Header>
<soap-env:Body>
<aml-block:Block xmlns:aml-block="http://www.example.com/2004/01/aml-block">
<aml-block:Header>
<aml-block:Type>http://www.example.com/2005/05/callhome/syslog</aml-block:Type>
<aml-block:CreationDate>2018-02-25 14:19:55 GMT+00:00</aml-block:CreationDate>
<aml-block:Builder>
<aml-block:Name>Cat6500</aml-block:Name>
<aml-block:Version>2.0</aml-block:Version>
</aml-block:Builder>
<aml-block:BlockGroup>
<aml-block:GroupId>G3:69000101:C9F9E20C</aml-block:GroupId>
<aml-block:Number>0</aml-block:Number>
<aml-block:IsLast>true</aml-block:IsLast>
<aml-block:IsPrimary>true</aml-block:IsPrimary>
<aml-block:WaitForPrimary>>false</aml-block:WaitForPrimary>
</aml-block:BlockGroup>
<aml-block:Severity>2</aml-block:Severity>
</aml-block:Header>
<aml-block:Content>
<ch:Call Home xmlns:ch="http://www.example.com/2005/05/callhome" version="1.0">
<ch:EventTime>2018-02-25 14:19:55 GMT+00:00</ch:EventTime>
<ch:MessageDescription>03:29:29: %CLEAR-5-COUNTERS: Clear counter on all
interfaces by console</ch:MessageDescription>
<ch:Event>
<ch:Type>syslog</ch:Type>
<ch:SubType>

```

```

</ch:SubType>
<ch:Brand>Cisco Systems</ch:Brand>
<ch:Series>Catalyst 6500 Series Switches</ch:Series>
</ch:Event>
<ch:CustomerData>
<ch:UserData>
<ch:Email>person@example.com</ch:Email>
</ch:UserData>
<ch:ContractData>
<ch:CustomerId>12345</ch:CustomerId>
<ch:SiteId>building 1</ch:SiteId>
<ch:ContractId>abcdefg12345</ch:ContractId>
<ch:DeviceId>WS-C6509@C@69000101</ch:DeviceId>
</ch:ContractData>
<ch:SystemInfo>
<ch:Name>Router</ch:Name>
<ch:Contact>
</ch:Contact>
<ch:ContactEmail>user@example.com</ch:ContactEmail>
<ch:ContactPhoneNumber>+1-408-555-1212</ch:ContactPhoneNumber>
<ch:StreetAddress>#1234 Any Street, Any City, Any State, 12345
</ch:StreetAddress>
</ch:SystemInfo>
</ch:CustomerData>
<ch:Device>
<rme:Chassis xmlns:rme="http://www.example.com/rme/4.0">
<rme:Model>WS-C6509</rme:Model>
<rme:HardwareVersion>1.0</rme:HardwareVersion>
<rme:SerialNumber>69000101</rme:SerialNumber>
<rme:AdditionalInformation>
<rme:AD name="PartNumber" value="73-3438-03 01" />
<rme:AD name="SoftwareVersion" value="4.0(20080421:012711)" />
</rme:AdditionalInformation>
</rme:Chassis>
</ch:Device>
</ch:Call Home>
</aml-block:Content>
<aml-block:Attachments>
<aml-block:Attachment type="inline">
<aml-block:Name>show logging</aml-block:Name>
<aml-block:Data encoding="plain">
<![CDATA[Syslog logging: enabled (0 messages dropped, 0 messages
rate-limited, 0 flushes, 0 overruns, xml disabled, filtering disabled)
  Console logging: level debugging, 53 messages logged, xml disabled,
filtering disabled  Monitor logging: level debugging, 0 messages logged,
xml disabled,filtering disabled  Buffer logging: level debugging,
53 messages logged, xml disabled,  filtering disabled  Exception
Logging: size (4096 bytes)  Count and timestamp logging messages: disabled
  Trap logging: level informational, 72 message lines logged
Log Buffer (8192 bytes):
00:00:54: curr is 0x20000
00:00:54: RP: Currently running ROMMON from F2 region
00:01:05: %SYS-5-CONFIG_I: Configured from memory by console
00:01:09: %SYS-5-RESTART: System restarted --Cisco IOS Software,
s72033_rp Software (s72033_rp-ADVENTERPRISEK9_DBG-VM), Experimental
Version 12.2(20070421:012711) Copyright (c) 1986-2007 by Cisco Systems, Inc.
Compiled Thu 26-Feb-18 15:54 by xxx
Firmware compiled 11-Apr-07 03:34 by integ Build [100]00:01:01: %PFREDUN-6-ACTIVE:
Initializing as ACTIVE processor for this switch00:01:01: %SYS-3-LOGGER_FLUSHED:
System was paused for 00:00:00 to ensure console debugging output.00:03:00: SP: SP:
Currently running ROMMON from F1 region00:03:07: %C6K_PLATFORM-SP-4-CONFREG_BREAK
_ENABLED: The default factory setting for config register is 0x2102.It is advisable
to retain 1 in 0x2102 as it prevents returning to ROMMON when break is issued.00:03:18:
%SYS-SP-5-RESTART: System restarted --Cisco IOS Software, s72033_sp Software

```



```

(s72033_sp-ADVENTERPRISEK9_DBG-VM), Experimental Version 12.2(20070421:012711)Copyright
(c) 1986-2007 by Cisco Systems, Inc.
Compiled Thu 26-Apr-07 18:00 by xxx
00:03:18: %SYS-SP-6-BOOTTIME: Time taken to reboot after reload = 339 seconds
00:03:18: %OIR-SP-6-INSFPS: Power supply inserted in slot 1
00:03:18: %C6KPWR-SP-4-PSOK: power supply 1 turned on.
00:03:18: %OIR-SP-6-INSFPS: Power supply inserted in slot00:01:09: %SSH-5-ENABLED:
SSH 1.99 has been enabled
00:03:18: %C6KPWR-SP-4-PSOK: power supply 2 turned on.
00:03:18: %C6KPWR-SP-4-PSREDUNDANTMISMATCH: power supplies rated outputs do not match.
00:03:18: %C6KPWR-SP-4-PSREDUNDANTBOTHSUPPLY: in power-redundancy mode, system is
operating on both power supplies.
00:01:10: %CRYPTO-6-ISAKMP_ON_OFF: ISAKMP is OFF
00:01:10: %CRYPTO-6-ISAKMP_ON_OFF: ISAKMP is OFF
00:03:20: %C6KENV-SP-4-FANHIOUTPUT: Version 2 high-output fan-tray is in effect
00:03:22: %C6KPWR-SP-4-PSNOREDUNDANCY: Power supplies are not in full redundancy,
power usage exceeds lower capacity supply
00:03:26: %FABRIC-SP-5-FABRIC_MODULE_ACTIVE: The Switch Fabric Module in slot 6
became active.
00:03:28: %DIAG-SP-6-RUN_MINIMUM: Module 6: Running Minimal Diagnostics...
00:03:50: %DIAG-SP-6-DIAG_OK: Module 6: Passed Online Diagnostics
00:03:50: %OIR-SP-6-INSCARD: Card inserted in slot 6, interfaces are now online
00:03:51: %DIAG-SP-6-RUN_MINIMUM: Module 3: Running Minimal Diagnostics...
00:03:51: %DIAG-SP-6-RUN_MINIMUM: Module 7: Running Minimal Diagnostics...
00:03:51: %DIAG-SP-6-RUN_MINIMUM: Module 9: Running Minimal Diagnostics...
00:01:51: %MFIB_CONST_RP-6-REPLICATION_MODE_CHANGE: Replication Mode Change Detected.
Current system replication mode is Ingress
00:04:01: %DIAG-SP-6-DIAG_OK: Module 3: Passed Online Diagnostics
00:04:01: %OIR-SP-6-DOWNGRADE: Fabric capable module 3 not at an appropriate hardware
revision level, and can only run in flowthrough mode
00:04:02: %OIR-SP-6-INSCARD: Card inserted in slot 3, interfaces are now online
00:04:11: %DIAG-SP-6-DIAG_OK: Module 7: Passed Online Diagnostics
00:04:14: %OIR-SP-6-INSCARD: Card inserted in slot 7, interfaces are now online
00:04:35: %DIAG-SP-6-DIAG_OK: Module 9: Passed Online Diagnostics
00:04:37: %OIR-SP-6-INSCARD: Card inserted in slot 9, interfaces are now online
00:00:09: DaughterBoard (Distributed Forwarding Card 3)
Firmware compiled 11-Apr-07 03:34 by integ Build [100]
00:00:22: %SYS-DFC4-5-RESTART: System restarted --
Cisco DCOS Software, c6lc2 Software (c6lc2-SPDBG-VM), Experimental Version 4.0
(20080421:012711)Copyright (c) 1986-2018 by Cisco Systems, Inc.
Compiled Thu 26-Feb-18 17:20 by xxx
00:00:23: DFC4: Currently running ROMMON from F2 region
00:00:25: %SYS-DFC2-5-RESTART: System restarted --
Cisco IOS Software, c6slc Software (c6slc-SPDBG-VM), Experimental Version 12.2
(20070421:012711)Copyright (c) 1986-2007 by Cisco Systems, Inc.
Compiled Thu 26-Apr-08 16:40 by username1
00:00:26: DFC2: Currently running ROMMON from F2 region
00:04:56: %DIAG-SP-6-RUN_MINIMUM: Module 4: Running Minimal Diagnostics...
00:00:09: DaughterBoard (Distributed Forwarding Card 3)
Firmware compiled 11-Apr-08 03:34 by integ Build [100]
slot_id is 8
00:00:31: %FLASHFS_HES-DFC8-3-BADCARD: /bootflash:: The flash card seems to
be corrupted
00:00:31: %SYS-DFC8-5-RESTART: System restarted --
Cisco DCOS Software, c6lc2 Software (c6lc2-SPDBG-VM), Experimental Version 4.0
(20080421:012711)Copyright (c) 1986-2008 by Cisco Systems, Inc.
Compiled Thu 26-Feb-18 17:20 by username1
00:00:31: DFC8: Currently running ROMMON from S (Gold) region
00:04:59: %DIAG-SP-6-RUN_MINIMUM: Module 2: Running Minimal Diagnostics...
00:05:12: %DIAG-SP-6-RUN_MINIMUM: Module 8: Running Minimal Diagnostics...
00:05:13: %DIAG-SP-6-RUN_MINIMUM: Module 1: Running Minimal Diagnostics...
00:00:24: %SYS-DFC1-5-RESTART: System restarted --
Cisco DCOS Software, c6slc Software (c6slc-SPDBG-VM), Experimental Version 4.0
(20080421:012711)Copyright (c) 1986-2008 by Cisco Systems, Inc.

```

```
Compiled Thu 26-Feb-18 16:40 by username1
00:00:25: DFC1: Currently running ROMMON from F2 region
00:05:30: %DIAG-SP-6-DIAG_OK: Module 4: Passed Online Diagnostics
00:05:31: %SPAN-SP-6-SPAN_EGRESS_REPLICATION_MODE_CHANGE: Span Egress HW
Replication Mode Change Detected. Current replication mode for unused asic
session 0 is Centralized
00:05:31: %SPAN-SP-6-SPAN_EGRESS_REPLICATION_MODE_CHANGE: Span Egress HW
Replication Mode Change Detected. Current replication mode for unused asic
session 1 is Centralized
00:05:31: %OIR-SP-6-INSCARD: Card inserted in slot 4, interfaces are now online
00:06:02: %DIAG-SP-6-DIAG_OK: Module 1: Passed Online Diagnostics
00:06:03: %OIR-SP-6-INSCARD: Card inserted in slot 1, interfaces are now online
00:06:31: %DIAG-SP-6-DIAG_OK: Module 2: Passed Online Diagnostics
00:06:33: %OIR-SP-6-INSCARD: Card inserted in slot 2, interfaces are now online
00:04:30: %XDR-6-XDRIPCNOTIFY: Message not sent to slot 4/0 (4) because of IPC
error timeout. Disabling linecard. (Expected during linecard OIR)
00:06:59: %DIAG-SP-6-DIAG_OK: Module 8: Passed Online Diagnostics
00:06:59: %OIR-SP-6-DOWNGRADE_EARL: Module 8 DFC installed is not identical to
system PFC and will perform at current system operating mode.
00:07:06: %OIR-SP-6-INSCARD: Card inserted in slot 8, interfaces are now online
Router#]]>
</aml-block:Data>
</aml-block:Attachment>
</aml-block:Attachments>
</aml-block:Block>
</soap-env:Body>
</soap-env:Envelope>
```



CHAPTER 7

Configuring Session Manager

This chapter contains the following sections:

- [Information About Session Manager, on page 83](#)
- [Guidelines and Limitations for Session Manager, on page 83](#)
- [Configuring Session Manager, on page 84](#)
- [Verifying the Session Manager Configuration, on page 86](#)

Information About Session Manager

Session Manager allows you to implement your configuration changes in batch mode. Session Manager works in the following phases:

- **Configuration session**—Creates a list of commands that you want to implement in session manager mode.
- **Validation**—Provides a basic semantic check on your configuration. Cisco NX-OS returns an error if the semantic check fails on any part of the configuration.
- **Verification**—Verifies the configuration as a whole, based on the existing hardware and software configuration and resources. Cisco NX-OS returns an error if the configuration does not pass this verification phase.
- **Commit**—Cisco NX-OS verifies the complete configuration and implements the changes atomically to the device. If a failure occurs, Cisco NX-OS reverts to the original configuration.
- **Abort**—Discards the configuration changes before implementation.

You can optionally end a configuration session without committing the changes. You can also save a configuration session.

Guidelines and Limitations for Session Manager

Session Manager has the following configuration guidelines and limitations:

- Session Manager supports only the access control list (ACL) feature.
- You can create up to 32 configuration sessions.
- You can configure a maximum of 20,000 commands across all sessions.

Configuring Session Manager

Creating a Session

You can create up to 32 configuration sessions.

SUMMARY STEPS

1. switch# **configure session** *name*
2. (Optional) switch(config-s)# **show configuration session** [*name*]
3. (Optional) switch(config-s)# **save** *location*

DETAILED STEPS

	Command or Action	Purpose
Step 1	switch# configure session <i>name</i>	Creates a configuration session and enters session configuration mode. The name can be any alphanumeric string. Displays the contents of the session.
Step 2	(Optional) switch(config-s)# show configuration session [<i>name</i>]	Displays the contents of the session.
Step 3	(Optional) switch(config-s)# save <i>location</i>	Saves the session to a file. The location can be in bootflash or volatile.

Configuring ACLs in a Session

You can configure ACLs within a configuration session.

SUMMARY STEPS

1. switch# **configure session** *name*
2. switch(config-s)# **ip access-list** *name*
3. (Optional) switch(config-s-acl)# **permit** *protocol source destination*
4. switch(config-s-acl)# **interface** *interface-type number*
5. switch(config-s-if)# **ip port access-group** *name in*
6. (Optional) switch# **show configuration session** [*name*]

DETAILED STEPS

	Command or Action	Purpose
Step 1	switch# configure session <i>name</i>	Creates a configuration session and enters session configuration mode. The name can be any alphanumeric string.

	Command or Action	Purpose
Step 2	switch(config-s)# ip access-list <i>name</i>	Creates an ACL.
Step 3	(Optional) switch(config-s-acl)# permit <i>protocol source destination</i>	Adds a permit statement to the ACL.
Step 4	switch(config-s-acl)# interface <i>interface-type number</i>	Enters interface configuration mode.
Step 5	switch(config-s-if)# ip port access-group <i>name in</i>	Adds a port access group to the interface.
Step 6	(Optional) switch# show configuration session [<i>name</i>]	Displays the contents of the session.

Verifying a Session

To verify a session, use the following command in session mode:

Command	Purpose
switch(config-s)# verify [verbose]	Verifies the commands in the configuration session.

Committing a Session

To commit a session, use the following command in session mode:

Command	Purpose
switch(config-s)# commit [verbose]	Commits the commands in the configuration session.

Saving a Session

To save a session, use the following command in session mode:

Command	Purpose
switch(config-s)# save <i>location</i>	(Optional) Saves the session to a file. The location can be in bootflash or volatile.

Discarding a Session

To discard a session, use the following command in session mode:

Command	Purpose
switch(config-s)# abort	Discards the configuration session without applying the commands.

Configuration Example for Session Manager

The following example shows how to create a configuration session for ACLs:

```

switch# configure session name test2
switch(config-s)# ip access-list acl2
switch(config-s-acl)# permit tcp any any
switch(config-s-acl)# exit
switch(config-s)# interface Ethernet 1/4
switch(config-s-ip)# ip port access-group acl2 in
switch(config-s-ip)# exit
switch(config-s)# verify
switch(config-s)# exit
switch# show configuration session test2

```

Verifying the Session Manager Configuration

To verify Session Manager configuration information, perform one of the following tasks:

Command	Purpose
show configuration session [<i>name</i>]	Displays the contents of the configuration session.
show configuration session status [<i>name</i>]	Displays the status of the configuration session.
show configuration session summary	Displays a summary of all the configuration sessions.



CHAPTER 8

Configuring the Scheduler

This chapter contains the following sections:

- [Information About the Scheduler, on page 87](#)
- [Guidelines and Limitations for the Scheduler, on page 88](#)
- [Default Settings for the Scheduler, on page 88](#)
- [Configuring the Scheduler, on page 89](#)
- [Verifying the Scheduler Configuration, on page 96](#)
- [Configuration Examples for the Scheduler, on page 96](#)
- [Standards for the Scheduler, on page 97](#)

Information About the Scheduler

The scheduler allows you to define and set a timetable for maintenance activities such as the following:

- Quality of service policy changes
- Data backup
- Saving a configuration

Jobs consist of a single command or multiple commands that define routine activities. Jobs can be scheduled one time or at periodic intervals.

The scheduler defines a job and its timetable as follows:

Job

A routine task or tasks defined as a command list and completed according to a specified schedule.

Schedule

The timetable for completing a job. You can assign multiple jobs to a schedule.

A schedule is defined as either periodic or one-time only:

- **Periodic mode**— A recurring interval that continues until you delete the job. You can configure the following types of intervals:
 - **Daily**— Job is completed once a day.
 - **Weekly**— Job is completed once a week.

- Monthly—Job is completed once a month.
- Delta—Job begins at the specified start time and then at specified intervals (days:hours:minutes).
- One-time mode—Job is completed only once at a specified time.

Remote User Authentication

Before starting a job, the scheduler authenticates the user who created the job. Because user credentials from a remote authentication are not retained long enough to support a scheduled job, you must locally configure the authentication passwords for users who create jobs. These passwords are part of the scheduler configuration and are not considered a locally configured user.

Before starting the job, the scheduler validates the local password against the password from the remote authentication server.

Scheduler Log Files

The scheduler maintains a log file that contains the job output. If the size of the job output is greater than the size of the log file, the output is truncated.

Guidelines and Limitations for the Scheduler

- The scheduler can fail if it encounters one of the following while performing a job:
 - If a feature license is expired when a job for that feature is scheduled.
 - If a feature is disabled at the time when a job for that feature is scheduled.
- Verify that you have configured the time. The scheduler does not apply a default timetable. If you create a schedule, assign jobs, and do not configure the time, the job is not started.
- While defining a job, verify that no interactive or disruptive commands (for example, **copy bootflash:file ftp:URI**, **write erase**, and other similar commands) are specified because the job is started and conducted noninteractively.

Default Settings for the Scheduler

Table 16: Default Command Scheduler Parameters

Parameters	Default
Scheduler state	Disabled
Log file size	16 KB

Configuring the Scheduler

Enabling the Scheduler

SUMMARY STEPS

1. switch# **configure terminal**
2. switch(config) # **feature scheduler**
3. (Optional) switch(config) # **show scheduler config**
4. (Optional) switch(config)# **copy running-config startup-config**

DETAILED STEPS

	Command or Action	Purpose
Step 1	switch# configure terminal	Enters global configuration mode.
Step 2	switch(config) # feature scheduler	Enables the scheduler.
Step 3	(Optional) switch(config) # show scheduler config	Displays the scheduler configuration.
Step 4	(Optional) switch(config)# copy running-config startup-config	Saves the change persistently through reboots and restarts by copying the running configuration to the startup configuration.

Example

This example shows how to enable the scheduler:

```
switch# configure terminal
switch(config)# feature scheduler
switch(config)# show scheduler config
config terminal
  feature scheduler
  scheduler logfile size 16
end
switch(config)#
```

Defining the Scheduler Log File Size

SUMMARY STEPS

1. switch# **configure terminal**
2. switch(config) # **scheduler logfile size value**
3. (Optional) switch(config)# **copy running-config startup-config**

DETAILED STEPS

	Command or Action	Purpose
Step 1	switch# configure terminal	Enters global configuration mode.
Step 2	switch(config) # scheduler logfile size <i>value</i>	Defines the scheduler log file size in kilobytes. The range is from 16 to 1024. The default log file size is 16. Note If the size of the job output is greater than the size of the log file, the output is truncated.
Step 3	(Optional) switch(config)# copy running-config startup-config	Saves the change persistently through reboots and restarts by copying the running configuration to the startup configuration.

Example

This example shows how to define the scheduler log file size:

```
switch# configure terminal
switch(config)# scheduler logfile size 1024
switch(config)#
```

Configuring Remote User Authentication

Remote users must authenticate with their clear text password before creating and configuring jobs.

Remote user passwords are always shown in encrypted form in the output of the **show running-config** command. The encrypted option (**7**) in the command supports the ASCII device configuration.

SUMMARY STEPS

1. switch# **configure terminal**
2. switch(config) # **scheduler aaa-authentication password** [0 | 7] *password*
3. switch(config) # **scheduler aaa-authentication username** *name* **password** [0 | 7] *password*
4. (Optional) switch(config) # **show running-config | include "scheduler aaa-authentication"**
5. (Optional) switch(config)# **copy running-config startup-config**

DETAILED STEPS

	Command or Action	Purpose
Step 1	switch# configure terminal	Enters global configuration mode.
Step 2	switch(config) # scheduler aaa-authentication password [0 7] <i>password</i>	Configures a password for the user who is currently logged in. To configure a clear text password, enter 0 . To configure an encrypted password, enter 7 .

	Command or Action	Purpose
Step 3	switch(config) # scheduler aaa-authentication username name password [0 7] password	Configures a clear text password for a remote user.
Step 4	(Optional) switch(config) # show running-config include "scheduler aaa-authentication"	Displays the scheduler password information.
Step 5	(Optional) switch(config) # copy running-config startup-config	Saves the change persistently through reboots and restarts by copying the running configuration to the startup configuration.

Example

This example shows how to configure a clear text password for a remote user called NewUser:

```
switch# configure terminal
switch(config) # scheduler aaa-authentication
username NewUser password z98y76x54b
switch(config) # copy running-config startup-config
switch(config) #
```

Defining a Job

After you define a job, you cannot modify or remove commands. To change the job, you must delete it and create a new one.

SUMMARY STEPS

1. switch# **configure terminal**
2. switch(config) # **scheduler job name name**
3. switch(config-job) # **command1 ; [command2 ;command3 ; ...**
4. (Optional) switch(config-job) # **show scheduler job [name]**
5. (Optional) switch(config-job) # **copy running-config startup-config**

DETAILED STEPS

	Command or Action	Purpose
Step 1	switch# configure terminal	Enters global configuration mode.
Step 2	switch(config) # scheduler job name name	Creates the job with the specified name and enters the job configuration mode. The <i>name</i> is restricted to 31 characters.
Step 3	switch(config-job) # command1 ; [command2 ;command3 ; ...	Defines the sequence of commands for the specified job. Separate commands with spaces and semicolons (;). Creates the filename using the current timestamp and switch name.
Step 4	(Optional) switch(config-job) # show scheduler job [name]	Displays the job information.

	Command or Action	Purpose
		The <i>name</i> is restricted to 31 characters.
Step 5	(Optional) switch(config-job) # copy running-config startup-config	Saves the change persistently through reboots and restarts by copying the running configuration to the startup configuration.

Example

This example shows how to:

- Create a scheduler job named "backup-cfg"
- Save the running configuration to a file in the bootflash
- Copy the file from the bootflash to a TFTP server
- Save the change to the startup configuration

```
switch# configure terminal
switch(config) # scheduler job name backup-cfg
switch(config-job) # copy running-config
tftp://1.2.3.4/${SWITCHNAME}-cfg.${TIMESTAMP} vrf management
switch(config-job) # copy running-config startup-config
```

Deleting a Job

SUMMARY STEPS

1. switch# **configure terminal**
2. switch(config) # **no scheduler job name name**
3. (Optional) switch(config-job) # **show scheduler job [name]**
4. (Optional) switch(config-job) # **copy running-config startup-config**

DETAILED STEPS

	Command or Action	Purpose
Step 1	switch# configure terminal	Enters global configuration mode.
Step 2	switch(config) # no scheduler job name name	Deletes the specified job and all commands defined within it. The <i>name</i> is restricted to 31 characters.
Step 3	(Optional) switch(config-job) # show scheduler job [name]	Displays the job information.
Step 4	(Optional) switch(config-job) # copy running-config startup-config	Saves the change persistently through reboots and restarts by copying the running configuration to the startup configuration.

Example

This example shows how to delete a job called configsave:

```
switch# configure terminal
switch(config)# no scheduler job name configsave
switch(config-job)# copy running-config startup-config
switch(config-job)#
```

Defining a Timetable

You must configure a timetable. Otherwise, jobs will not be scheduled.

If you do not specify the time for the **time** commands, the scheduler assumes the current time. For example, if the current time is March 24, 2008, 22:00 hours, jobs are started as follows:

- For the **time start 23:00 repeat 4:00:00** command, the scheduler assumes a start time of March 24, 2008, 23:00 hours.
- For the **time daily 55** command, the scheduler assumes a start time every day at 22:55 hours.
- For the **time weekly 23:00** command, the scheduler assumes a start time every Friday at 23:00 hours.
- For the **time monthly 23:00** command, the scheduler assumes a start time on the 24th of every month at 23:00 hours.



Note The scheduler will not begin the next occurrence of a job before the last one completes. For example, you have scheduled a job to be completed at one-minute intervals beginning at 22:00; but the job requires two minutes to complete. The scheduler starts the first job at 22:00, completes it at 22:02, and then observes a one-minute interval before starting the next job at 22:03.

SUMMARY STEPS

1. switch# **configure terminal**
2. switch(config) # **scheduler schedule name** *name*
3. switch(config-schedule) # **job name** *name*
4. switch(config-schedule) # **time daily** *time*
5. switch(config-schedule) # **time weekly** *[[day-of-week:] HH:] MM*
6. switch(config-schedule) # **time monthly** *[[day-of-month:] HH:] MM*
7. switch(config-schedule) # **time start** {**now repeat** *repeat-interval* | *delta-time* [**repeat** *repeat-interval*]}
8. (Optional) switch(config-schedule) # **show scheduler config**
9. (Optional) switch(config-schedule) # **copy running-config startup-config**

DETAILED STEPS

	Command or Action	Purpose
Step 1	switch# configure terminal	Enters global configuration mode.

	Command or Action	Purpose
Step 2	switch(config) # scheduler schedule name <i>name</i>	Creates a new scheduler and enters schedule configuration mode for that schedule. The <i>name</i> is restricted to 31 characters.
Step 3	switch(config-schedule) # job name <i>name</i>	Associates a job with this schedule. You can add multiple jobs to a schedule. The <i>name</i> is restricted to 31 characters.
Step 4	switch(config-schedule) # time daily <i>time</i>	Indicates the job starts every day at a designated time, specified as HH:MM.
Step 5	switch(config-schedule) # time weekly [[<i>day-of-week:</i>] <i>HH:</i>] <i>MM</i>	Indicates that the job starts on a specified day of the week. The day of the week is represented by an integer (for example, 1 for Sunday, 2 for Monday) or as an abbreviation (for example, sun , mon). The maximum length for the entire argument is 10 characters.
Step 6	switch(config-schedule) # time monthly [[<i>day-of-month:</i>] <i>HH:</i>] <i>MM</i>	Indicates that the job starts on a specified day each month. If you specify 29, 30, or 31, the job is started on the last day of each month.
Step 7	switch(config-schedule) # time start { now repeat <i>repeat-interval</i> <i>delta-time</i> [repeat <i>repeat-interval</i>]}	Indicates the job starts periodically. The start-time format is [[[yyyy:]mmm:]dd:]HH]:MM. <ul style="list-style-type: none"> • <i>delta-time</i>— Specifies the amount of time to wait after the schedule is configured before starting a job. • now— Specifies that the job starts two minutes from now. • repeat <i>repeat-interval</i>— Specifies the frequency at which the job is repeated.
Step 8	(Optional) switch(config-schedule) # show scheduler config	Displays the scheduler information.
Step 9	(Optional) switch(config-schedule) # copy running-config startup-config	Saves the change persistently through reboots and restarts by copying the running configuration to the startup configuration.

Example

This example shows how to define a timetable where jobs start on the 28th of each month at 23:00 hours:

```
switch# configure terminal
switch(config)# scheduler schedule name weekendbackupqos
switch(config-scheduler)# job name offpeakzoning
```

```
switch(config-scheduler) # time monthly 28:23:00
switch(config-scheduler) # copy running-config startup-config
switch(config-scheduler) #
```

Clearing the Scheduler Log File

SUMMARY STEPS

1. switch# **configure terminal**
2. switch(config) # **clear scheduler logfile**

DETAILED STEPS

	Command or Action	Purpose
Step 1	switch# configure terminal	Enters global configuration mode.
Step 2	switch(config) # clear scheduler logfile	Clears the scheduler log file.

Example

This example shows how to clear the scheduler log file:

```
switch# configure terminal
switch(config) # clear scheduler logfile
```

Disabling the Scheduler

SUMMARY STEPS

1. switch# **configure terminal**
2. switch(config) # **no feature scheduler**
3. (Optional) switch(config) # **show scheduler config**
4. (Optional) switch(config) # **copy running-config startup-config**

DETAILED STEPS

	Command or Action	Purpose
Step 1	switch# configure terminal	Enters global configuration mode.
Step 2	switch(config) # no feature scheduler	Disables the scheduler.
Step 3	(Optional) switch(config) # show scheduler config	Displays the scheduler configuration.
Step 4	(Optional) switch(config) # copy running-config startup-config	Saves the change persistently through reboots and restarts by copying the running configuration to the startup configuration.

Example

This example shows how to disable the scheduler:

```
switch# configure terminal
switch(config) # no feature scheduler
switch(config) # copy running-config startup-config
switch(config) #
```

Verifying the Scheduler Configuration

Use one of the following commands to verify the configuration:

Table 17: Scheduler Show Commands

Command	Purpose
<code>show scheduler config</code>	Displays the scheduler configuration.
<code>show scheduler job [name name]</code>	Displays the jobs configured.
<code>show scheduler logfile</code>	Displays the contents of the scheduler log file.
<code>show scheduler schedule [name name]</code>	Displays the schedules configured.

Configuration Examples for the Scheduler

Creating a Scheduler Job

This example shows how to create a scheduler job that saves the running configuration to a file in the bootflash. The job then copies the file from the bootflash to a TFTP server (the filename is created using the current timestamp and switch name):

```
switch# configure terminal
switch(config)# scheduler job name backup-cfg
switch(config-job)# copy running-config
tftp://1.2.3.4/${SWITCHNAME}-cfg.${TIMESTAMP} vrf management
switch(config-job)# end
switch(config)#
```

Scheduling a Scheduler Job

This example shows how to schedule a scheduler job called backup-cfg to run daily at 1 a.m.:

```
switch# configure terminal
switch(config)# scheduler schedule name daily
switch(config-schedule)# job name backup-cfg
switch(config-schedule)# time daily 1:00
switch(config-schedule)# end
switch(config)#
```

Displaying the Job Schedule

This example shows how to display the job schedule:

```
switch# show scheduler schedule
Schedule Name      : daily
-----
User Name         : admin
Schedule Type     : Run every day at 1 Hrs 00 Mins
Last Execution Time : Fri Jan 2 1:00:00 2009
Last Completion Time: Fri Jan 2 1:00:01 2009
Execution count   : 2
-----
      Job Name          Last Execution Status
-----
back-cfg                Success (0)
switch(config)#
```

Displaying the Results of Running Scheduler Jobs

This example shows how to display the results of scheduler jobs that have been executed by the scheduler:

```
switch# show scheduler logfile
Job Name           : back-cfg                Job Status: Failed (1)
Schedule Name     : daily                   User Name : admin
Completion time:  Fri Jan 1  1:00:01 2009
----- Job Output -----
`cli var name timestamp 2009-01-01-01.00.00`
`copy running-config bootflash:/$(HOSTNAME)-cfg.$(timestamp)`
`copy bootflash:/switch-cfg.2009-01-01-01.00.00 tftp://1.2.3.4/ vrf management `
copy: cannot access file '/bootflash/switch-cfg.2009-01-01-01.00.00'
=====
Job Name           : back-cfg                Job Status: Success (0)
Schedule Name     : daily                   User Name : admin
Completion time:  Fri Jan 2  1:00:01 2009
----- Job Output -----
`cli var name timestamp 2009-01-02-01.00.00`
`copy running-config bootflash:/switch-cfg.2009-01-02-01.00.00`
`copy bootflash:/switch-cfg.2009--01-02-01.00.00 tftp://1.2.3.4/ vrf management `
Connection to Server Established.
[                               ] 0.50KBTrying to connect to tftp server.....
[#####] 24.50KB
TFTP put operation was successful
=====
switch#
```

Standards for the Scheduler

No new or modified standards are supported by this feature, and support for existing standards has not been modified by this feature.



CHAPTER 9

Configuring SNMP

This chapter contains the following sections:

- [Information About SNMP](#), on page 99
- [Guidelines and Limitations for SNMP](#), on page 103
- [Default SNMP Settings](#), on page 103
- [Configuring SNMP](#), on page 104
- [Disabling SNMP](#), on page 115
- [Verifying the SNMP Configuration](#), on page 116
- [Additional References](#), on page 116

Information About SNMP

The Simple Network Management Protocol (SNMP) is an application-layer protocol that provides a message format for communication between SNMP managers and agents. SNMP provides a standardized framework and a common language used for the monitoring and management of devices in a network.

SNMP Functional Overview

The SNMP framework consists of three parts:

- An SNMP manager—The system used to control and monitor the activities of network devices using SNMP.
- An SNMP agent—The software component within the managed device that maintains the data for the device and reports these data, as needed, to managing systems. The Cisco Nexus device supports the agent and MIB. To enable the SNMP agent, you must define the relationship between the manager and the agent.
- A managed information base (MIB)—The collection of managed objects on the SNMP agent



Note Cisco NX-OS does not support SNMP sets for Ethernet MIBs.

The Cisco Nexus device supports SNMPv1, SNMPv2c, and SNMPv3. Both SNMPv1 and SNMPv2c use a community-based form of security.

SNMP is defined in RFC 3410 (<http://tools.ietf.org/html/rfc3410>), RFC 3411 (<http://tools.ietf.org/html/rfc3411>), RFC 3412 (<http://tools.ietf.org/html/rfc3412>), RFC 3413 (<http://tools.ietf.org/html/rfc3413>), RFC 3414 (<http://tools.ietf.org/html/rfc3414>), RFC 3415 (<http://tools.ietf.org/html/rfc3415>), RFC 3416 (<http://tools.ietf.org/html/rfc3416>), RFC 3417 (<http://tools.ietf.org/html/rfc3417>), RFC 3418 (<http://tools.ietf.org/html/rfc3418>), and RFC 3584 (<http://tools.ietf.org/html/rfc3584>).

SNMP Notifications

A key feature of SNMP is the ability to generate notifications from an SNMP agent. These notifications do not require that requests be sent from the SNMP manager. Notifications can indicate improper user authentication, restarts, the closing of a connection, loss of connection to a neighbor router, or other significant events.

Cisco NX-OS generates SNMP notifications as either traps or informs. A trap is an asynchronous, unacknowledged message sent from the agent to the SNMP managers listed in the host receiver table. Informs are asynchronous messages sent from the SNMP agent to the SNMP manager which the manager must acknowledge receipt of.

Traps are less reliable than informs because the SNMP manager does not send any acknowledgment when it receives a trap. The switch cannot determine if the trap was received. An SNMP manager that receives an inform request acknowledges the message with an SNMP response protocol data unit (PDU). If the Cisco Nexus device never receives a response, it can send the inform request again.

You can configure Cisco NX-OS to send notifications to multiple host receivers.

SNMPv3

SNMPv3 provides secure access to devices by a combination of authenticating and encrypting frames over the network. The security features provided in SNMPv3 are the following:

- Message integrity—Ensures that a packet has not been tampered with in-transit.
- Authentication—Determines the message is from a valid source.
- Encryption—Scrambles the packet contents to prevent it from being seen by unauthorized sources.

SNMPv3 provides for both security models and security levels. A security model is an authentication strategy that is set up for a user and the role in which the user resides. A security level is the permitted level of security within a security model. A combination of a security model and a security level determines which security mechanism is employed when handling an SNMP packet.

Security Models and Levels for SNMPv1, v2, and v3

The security level determines if an SNMP message needs to be protected from disclosure and if the message needs to be authenticated. The various security levels that exist within a security model are as follows:

- noAuthNoPriv—Security level that does not provide authentication or encryption. This level is not supported for SNMPv3.
- authNoPriv—Security level that provides authentication but does not provide encryption.
- authPriv—Security level that provides both authentication and encryption.

Three security models are available: SNMPv1, SNMPv2c, and SNMPv3. The security model combined with the security level determine the security mechanism applied when the SNMP message is processed.

Table 18: SNMP Security Models and Levels

Model	Level	Authentication	Encryption	What Happens
v1	noAuthNoPriv	Community string	No	Uses a community string match for authentication.
v2c	noAuthNoPriv	Community string	No	Uses a community string match for authentication.
v3	authNoPriv	HMAC-MD5, HMAC-SHA, or SHA-256	No	Provides authentication based on the Hash-Based Message Authentication Code (HMAC) Message Digest 5 (MD5) algorithm or the HMAC Secure Hash Algorithm (SHA).
v3	authPriv	HMAC-MD5, HMAC-SHA, or SHA-256	DES	Provides authentication based on the HMAC-MD5 or HMAC-SHA algorithms. Provides Data Encryption Standard (DES) 56-bit encryption in addition to authentication based on the Cipher Block Chaining (CBC) DES (DES-56) standard.

User-Based Security Model

SNMPv3 User-Based Security Model (USM) refers to SNMP message-level security and offers the following services:

- Message integrity—Ensures that messages have not been altered or destroyed in an unauthorized manner and that data sequences have not been altered to an extent greater than can occur nonmaliciously.
- Message origin authentication—Confirms that the claimed identity of the user who received the data was originated.
- Message confidentiality—Ensures that information is not made available or disclosed to unauthorized individuals, entities, or processes.

SNMPv3 authorizes management operations only by configured users and encrypts SNMP messages.

Cisco NX-OS uses two authentication protocols for SNMPv3:

- HMAC-MD5-96 authentication protocol
- HMAC-SHA-96 authentication protocol
- SHA-256 authentication protocol

Beginning with Cisco NX-OS release 9.3(7), HMAC-SHA-256 authentication protocol is used for SNMPv3.



Note When SHA-256 SNMP users are configured on the switch, ISSD is recommended by **install all** cmd else there will be config loss.

Cisco NX-OS uses Advanced Encryption Standard (AES) as one of the privacy protocols for SNMPv3 message encryption and conforms with RFC 3826.

The **priv** option offers a choice of DES or 128-bit AES encryption for SNMP security encryption. The **priv** option and the **aes-128** token indicates that this privacy password is for generating a 128-bit AES key #. The AES priv password can have a minimum of eight characters. If the passphrases are specified in clear text, you can specify a maximum of 64 characters. If you use the localized key, you can specify a maximum of 130 characters.



Note For an SNMPv3 operation using the external AAA server, you must use AES for the privacy protocol in user configuration on the external AAA server.

CLI and SNMP User Synchronization

SNMPv3 user management can be centralized at the Access Authentication and Accounting (AAA) server level. This centralized user management allows the SNMP agent in Cisco NX-OS to leverage the user authentication service of the AAA server. Once user authentication is verified, the SNMP PDUs are processed further. Additionally, the AAA server is also used to store user group names. SNMP uses the group names to apply the access/role policy that is locally available in the switch.

Any configuration changes made to the user group, role, or password results in database synchronization for both SNMP and AAA.

Cisco NX-OS synchronizes user configuration in the following ways:

- The **auth** passphrase specified in the **snmp-server user** command becomes the password for the CLI user.
- The password specified in the **username** command becomes the **auth** and **priv** passphrases for the SNMP user.
- If you create or delete a user using either SNMP or the CLI, the user is created or deleted for both SNMP and the CLI.
- User-role mapping changes are synchronized in SNMP and the CLI.
- Role changes (deletions or modifications from the CLI) are synchronized to SNMP.



Note When you configure passphrase/password in localized key/encrypted format, Cisco NX-OS does not synchronize the user information (passwords, rules, etc.).

Group-Based SNMP Access



Note Because a group is a standard SNMP term used industry-wide, roles are referred to as groups in this SNMP section.

SNMP access rights are organized by groups. Each group in SNMP is similar to a role through the CLI. Each group is defined with three accesses: read access, write access, and notification access. Each access can be enabled or disabled within each group.

You can begin communicating with the agent once your username is created, your roles are set up by your administrator, and you are added to the roles.

Guidelines and Limitations for SNMP

- Cisco NX-OS supports read-only access to Ethernet MIBs. For more information about supported MIBs, see the following URL:
<ftp://ftp.cisco.com/pub/mibs/supportlists/nexus3000/Nexus3000MIBSupportList.html>
- Cisco NX-OS does not support the SNMPv3 noAuthNoPriv security level.
- Cisco Nexus 3548 switches support upto 10000 flash files for request.
- Commands configured using SNMP SET should be deleted using SNMP SET only. Commands configured using Command Line Interface(CLI) or NX-API should be deleted using CLI or NX-API only.

Default SNMP Settings

Table 19: Default SNMP Parameters

Parameters	Default
license notifications	Enabled
linkUp/Down notification type	ietf-extended

Configuring SNMP

Configuring SNMP Users



Note The commands used to configure SNMP users in Cisco NX-OS are different from those used to configure users in Cisco IOS.

SUMMARY STEPS

1. **configure terminal**
2. **snmp-server user** *name* [auth {md5 | sha | sha-256} *passphrase* [auto] [priv [aes-128] *passphrase*] [engineID *id*] [localizedkey] [localizedV2key]]
3. (Optional) switch# **show snmp user**
4. (Optional) **copy running-config startup-config**

DETAILED STEPS

	Command or Action	Purpose
Step 1	configure terminal Example: switch# configure terminal switch(config)#	Enters global configuration mode.
Step 2	snmp-server user <i>name</i> [auth {md5 sha sha-256} <i>passphrase</i> [auto] [priv [aes-128] <i>passphrase</i>] [engineID <i>id</i>] [localizedkey] [localizedV2key]] Example: switch(config)# snmp-server user Admin auth sha abcd1234 priv abcdefgh	Configures an SNMP user with authentication and privacy parameters. The passphrase can be any case-sensitive, alphanumeric string up to 64 characters. If you use the localizedkey keyword, the passphrase can be any case-sensitive, alphanumeric string up to 130 characters. If the localizedV2key is used, the passphrase can be any case-sensitive, alphanumeric string upto 130 char without 0x/0X at the beginning. It is always preferred to collect localizedV2key from "show runn" since this is an encrypted data and cannot be generated offline. The engineID format is a 12-digit, colon-separated decimal number.
Step 3	(Optional) switch# show snmp user Example: switch(config)# show snmp user	Displays information about one or more SNMP users.

	Command or Action	Purpose
Step 4	(Optional) copy running-config startup-config Example: <code>switch(config)# copy running-config startup-config</code>	Saves the change persistently through reboots and restarts by copying the running configuration to the startup configuration.

Example

The following example shows how to configure an SNMP user:

```
switch# config t
Enter configuration commands, one per line. End with CNTL/Z.
switch(config)# snmp-server user Admin auth sha abcd1234 priv abcdefgh
```

Enforcing SNMP Message Encryption

You can configure SNMP to require authentication or encryption for incoming requests. By default, the SNMP agent accepts SNMPv3 messages without authentication and encryption. When you enforce privacy, Cisco NX-OS responds with an authorization error for any SNMPv3 PDU request that uses a security level parameter of either **noAuthNoPriv** or **authNoPriv**.

Use the following command in global configuration mode to enforce SNMP message encryption for a specific user:

Command	Purpose
<code>switch(config)# snmp-server user name enforcePriv</code>	Enforces SNMP message encryption for this user.

Use the following command in global configuration mode to enforce SNMP message encryption for all users:

Command	Purpose
<code>switch(config)# snmp-server globalEnforcePriv</code>	Enforces SNMP message encryption for all users.

Assigning SNMPv3 Users to Multiple Roles

After you configure an SNMP user, you can assign multiple roles for the user.



Note Only users who belong to a network-admin role can assign roles to other users.

Command	Purpose
<code>switch(config)# snmp-server user name group</code>	Associates this SNMP user with the configured user role.

Creating SNMP Communities

You can create SNMP communities for SNMPv1 or SNMPv2c.

Command	Purpose
switch(config)# snmp-server community <i>name group</i> { ro rw }	Creates an SNMP community string.

Filtering SNMP Requests

You can assign an access list (ACL) to a community to filter incoming SNMP requests. If the assigned ACL allows the incoming request packet, SNMP processes the request. If the ACL denies the request, SNMP drops the request and sends a system message.

Create the ACL with the following parameters:

- Source IP address
- Destination IP address
- Source port
- Destination port
- Protocol (UDP or TCP)

The ACL applies to both IPv4 and IPv6 over UDP and TCP. After creating the ACL, assign the ACL to the SNMP community.



Tip For more information about creating ACLs, see the NX-OS security configuration guide for the Cisco Nexus Series software that you are using.

Use the following command in global configuration mode to assign an IPv4 or IPv6 ACL to an SNMPv3 community to filter SNMP requests:

Command	Purpose
switch(config)# snmp-server community <i>name</i> [use-ipv4acl <i>ipv4acl-name</i>] [use-ipv6acl <i>ipv6acl-name</i>] switch(config)# snmp-server community public use-ipv4acl myacl	Assigns an IPv4 or IPv6 ACL to an SNMPv3 community to filter SNMP requests.

Configuring SNMP Notification Receivers

You can configure Cisco NX-OS to generate SNMP notifications to multiple host receivers.

You can configure a host receiver for SNMPv1 traps in a global configuration mode.

Command	Purpose
switch(config)# snmp-server host <i>ip-address</i> traps version 1 <i>community</i> [udp_port <i>number</i>]	Configures a host receiver for SNMPv1 traps. The <i>ip-address</i> can be an IPv4 or IPv6 address. The community can be any alphanumeric string up to 255 characters. The UDP port number range is from 0 to 65535.

You can configure a host receiver for SNMPv2c traps or informs in a global configuration mode.

Command	Purpose
switch(config)# snmp-server host <i>ip-address</i> { traps informs } version 2c <i>community</i> [udp_port <i>number</i>]	Configures a host receiver for SNMPv2c traps or informs. The <i>ip-address</i> can be an IPv4 or IPv6 address. The community can be any alphanumeric string up to 255 characters. The UDP port number range is from 0 to 65535.

You can configure a host receiver for SNMPv3 traps or informs in a global configuration mode.

Command	Purpose
switch(config)# snmp-server host <i>ip-address</i> { traps informs } version 3 { auth noauth priv } <i>username</i> [udp_port <i>number</i>]	Configures a host receiver for SNMPv3 traps or informs. The <i>ip-address</i> can be an IPv4 or IPv6 address. The username can be any alphanumeric string up to 255 characters. The UDP port number range is from 0 to 65535.



Note The SNMP manager must know the user credentials (authKey/PrivKey) based on the SNMP engineID of the Cisco Nexus device to authenticate and decrypt the SNMPv3 messages.

The following example shows how to configure a host receiver for an SNMPv1 trap:

```
switch(config)# snmp-server host 192.0.2.1 traps version 1 public
```

The following example shows how to configure a host receiver for an SNMPv2 inform:

```
switch(config)# snmp-server host 192.0.2.1 informs version 2c public
```

The following example shows how to configure a host receiver for an SNMPv3 inform:

```
switch(config)# snmp-server host 192.0.2.1 informs version 3 auth NMS
```

Configuring SNMP Notification Receivers with VRFs

You can configure Cisco NX-OS to use a configured VRF to reach the host receiver. SNMP adds entries into the cExtSnmpTargetVrfTable of the CISCO-SNMP-TARGET-EXT-MIB when you configure the VRF reachability and filtering options for an SNMP notification receiver.



Note You must configure the host before configuring the VRF reachability or filtering options.

SUMMARY STEPS

1. switch# **configure terminal**
2. switch# **snmp-server host ip-address use-vrf vrf_name [udp_port number]**
3. (Optional) switch(config)# **copy running-config startup-config**

DETAILED STEPS

	Command or Action	Purpose
Step 1	switch# configure terminal	Enters global configuration mode.
Step 2	switch# snmp-server host ip-address use-vrf vrf_name [udp_port number]	Configures SNMP to use the selected VRF to communicate with the host receiver. The IP address can be an IPv4 or IPv6 address. The VRF name can be any alphanumeric string up to 255 characters. The UDP port number range is from 0 to 65535. This command adds an entry into the ExtSnpTargetVrfTable of the CISCO-SNMP-TARGET-EXT-MB.
Step 3	(Optional) switch(config)# copy running-config startup-config	Saves the change persistently through reboots and restarts by copying the running configuration to the startup configuration.

Example

The following example shows how to configure the SNMP server host with IP address 192.0.2.1 to use the VRF named "Blue:"

```
switch# configuration terminal
switch(config)# snmp-server host 192.0.2.1 use-vrf Blue
switch(config)# copy running-config startup-config
```

Filtering SNMP Notifications Based on a VRF

You can configure Cisco NX-OS filter notifications based on the VRF in which the notification occurred.

SUMMARY STEPS

1. switch# **configure terminal**
2. switch(config)# **snmp-server host ip-address filter-vrf vrf_name [udp_port number]**
3. (Optional) switch(config)# **copy running-config startup-config**

DETAILED STEPS

	Command or Action	Purpose
Step 1	switch# configure terminal	Enters global configuration mode.
Step 2	switch(config)# snmp-server host ip-address filter-vrf vrf_name [udp_port number]	Filters notifications to the notification host receiver based on the configured VRF. The IP address can be an IPv4 or IPv6 address. The VRF name can be any alphanumeric

	Command or Action	Purpose
		string up to 255 characters. The UDP port number range is from 0 to 65535. This command adds an entry into the ExtSnmpTargetVrfTable of the CISCO-SNMP-TARGET-EXT-MB.
Step 3	(Optional) switch(config)# copy running-config startup-config	Saves the change persistently through reboots and restarts by copying the running configuration to the startup configuration.

Example

The following example shows how to configure filtering of SNMP notifications based on a VRF:

```
switch# configuration terminal
switch(config)# snmp-server host 192.0.2.1 filter-vrf Red
switch(config)# copy running-config startup-config
```

Configuring SNMP for Inband Access

You can configure SNMP for inband access using the following:

- Using SNMP v2 without context—You can use a community that is mapped to a context. In this case, the SNMP client does not need to know about the context.
- Using SNMP v2 with context—The SNMP client needs to specify the context by specifying a community; for example, <community>@<context>.
- Using SNMP v3—You can specify the context.

SUMMARY STEPS

1. switch# **configuration terminal**
2. switch(config)# **snmp-server context** *context-name* **vrf** *vrf-name*
3. switch(config)# **snmp-server community** *community-name* **group** *group-name*
4. switch(config)# **snmp-server mib community-map** *community-name* **context** *context-name*

DETAILED STEPS

	Command or Action	Purpose
Step 1	switch# configuration terminal	Enters global configuration mode.
Step 2	switch(config)# snmp-server context <i>context-name</i> vrf <i>vrf-name</i>	Maps an SNMP context to the management VRF or default VRF. Custom VRFs are not supported. The names can be any alphanumeric string up to 32 characters.

	Command or Action	Purpose
		Note By default, SNMP sends the traps using the management VRF. If you do not want to use the management VRF, you must use this command to specify the desired VRF.
Step 3	switch(config)# snmp-server community <i>community-name</i> group <i>group-name</i>	Maps an SNMPv2c community to an SNMP context and identifies the group to which the community belongs. The names can be any alphanumeric string up to 32 characters.
Step 4	switch(config)# snmp-server mib community-map <i>community-name</i> context <i>context-name</i>	Maps an SNMPv2c community to an SNMP context. The names can be any alphanumeric string up to 32 characters.

Example

The following SNMPv2 example shows how to map a community named snmpdefault to a context:

```
switch# config t
Enter configuration commands, one per line. End with CNTL/Z.
switch(config)# snmp-server context def vrf default
switch(config)# snmp-server community snmpdefault group network-admin
switch(config)# snmp-server mib community-map snmpdefault context def
switch(config)#
```

The following SNMPv2 example shows how to configure and inband access to the community comm which is not mapped:

```
switch# config t
Enter configuration commands, one per line. End with CNTL/Z.
switch(config)# snmp-server context def vrf default
switch(config)# snmp-server community comm group network-admin
switch(config)#
```

The following SNMPv3 example shows how to use a v3 username and password:

```
switch# config t
Enter configuration commands, one per line. End with CNTL/Z.
switch(config)# snmp-server context def vrf default
switch(config)#
```

Enabling SNMP Notifications

You can enable or disable notifications. If you do not specify a notification name, Cisco NX-OS enables all notifications.



Note The **snmp-server enable traps** CLI command enables both traps and informs, depending on the configured notification host receivers.

The following table lists the CLI commands that enable the notifications for Cisco NX-OS MIBs.

Table 20: Enabling SNMP Notifications

MIB	Related Commands
All notifications	snmp-server enable traps
BRIDGE-MIB	snmp-server enable traps bridge newroot snmp-server enable traps bridge topologychange
CISCO-AAA-SERVER-MIB	snmp-server enable traps aaa
ENTITY-MIB, CISCO-ENTITY-FRU-CONTROL-MIB, CISCO-ENTITY-SENSOR-MIB	snmp-server enable traps entity snmp-server enable traps entity fru
CISCO-LICENSE-MGR-MIB	snmp-server enable traps license
IF-MIB	snmp-server enable traps link
CISCO-PSM-MIB	snmp-server enable traps port-security
SNMPv2-MIB	snmp-server enable traps snmp snmp-server enable traps snmp authentication
CISCO-FCC-MIB	snmp-server enable traps fcc
CISCO-DM-MIB	snmp-server enable traps fcdomain
CISCO-NS-MIB	snmp-server enable traps fcns
CISCO-FCS-MIB	snmp-server enable traps fcs discovery-complete snmp-server enable traps fcs request-reject
CISCO-FDMI-MIB	snmp-server enable traps fdmi
CISCO-FSPF-MIB	snmp-server enable traps fspf
CISCO-PSM-MIB	snmp-server enable traps port-security
CISCO-RSCN-MIB	snmp-server enable traps rscn snmp-server enable traps rscn els snmp-server enable traps rscn ils

MIB	Related Commands
CISCO-ZS-MIB	snmp-server enable traps zone snmp-server enable traps zone default-zone-behavior-change snmp-server enable traps zone enhanced-zone-db-change snmp-server enable traps zone merge-failure snmp-server enable traps zone merge-success snmp-server enable traps zone request-reject snmp-server enable traps zone unsupp-mem
CISCO-CONFIG-MAN-MIB	snmp-server enable traps config
Note Supports no MIB objects except the following notification: ccmCLIRunningConfigChanged	



Note The license notifications are enabled by default.

To enable the specified notification in the global configuration mode, perform one of the following tasks:

Command	Purpose
switch(config)# snmp-server enable traps	Enables all SNMP notifications.
switch(config)# snmp-server enable traps aaa [server-state-change]	Enables the AAA SNMP notifications.
switch(config)# snmp-server enable traps entity [fru]	Enables the ENTITY-MIB SNMP notifications.
switch(config)# snmp-server enable traps license	Enables the license SNMP notification.
switch(config)# snmp-server enable traps port-security	Enables the port security SNMP notifications.
switch(config)# snmp-server enable traps snmp [authentication]	Enables the SNMP agent notifications.

Configuring Link Notifications

You can configure which linkUp/linkDown notifications to enable on a device. You can enable the following types of linkUp/linkDown notifications:

- **cieLinkDown**—Enables the Cisco extended link state down notification.
- **cieLinkUp**—Enables the Cisco extended link state up notification.
- **cisco-xcvr-mon-status-chg**—Enables the Cisco interface transceiver monitor status change notification.
- **delayed-link-state-change**—Enables the delayed link state change.

- `extended-linkUp`—Enables the Internet Engineering Task Force (IETF) extended link state up notification.
- `extended-linkDown`—Enables the IETF extended link state down notification.
- `linkDown`—Enables the IETF Link state down notification.
- `linkUp`—Enables the IETF Link state up notification.

SUMMARY STEPS

1. **configure terminal**
2. **snmp-server enable traps link [cieLinkDown | cieLinkUp | cisco-xcvr-mon-status-chg | delayed-link-state-change] | extended-linkUp | extended-linkDown | linkDown | linkUp]**

DETAILED STEPS

	Command or Action	Purpose
Step 1	configure terminal Example: <pre>switch# configure terminal switch(config)#</pre>	Enters global configuration mode.
Step 2	snmp-server enable traps link [cieLinkDown cieLinkUp cisco-xcvr-mon-status-chg delayed-link-state-change] extended-linkUp extended-linkDown linkDown linkUp] Example: <pre>switch(config)# snmp-server enable traps link cieLinkDown</pre>	Enables the link SNMP notifications.

Disabling Link Notifications on an Interface

You can disable `linkUp` and `linkDown` notifications on an individual interface. You can use these limit notifications on a flapping interface (an interface that transitions between up and down repeatedly).

SUMMARY STEPS

1. **switch# configure terminal**
2. **switch(config)# interface *type slot/port***
3. **switch(config-if)# no snmp trap link-status**

DETAILED STEPS

	Command or Action	Purpose
Step 1	switch# configure terminal	Enters global configuration mode.
Step 2	switch(config)# interface <i>type slot/port</i>	Specifies the interface to be changed.

	Command or Action	Purpose
Step 3	switch(config-if)# no snmp trap link-status	Disables SNMP link-state traps for the interface. This feature is enabled by default.

Enabling One-Time Authentication for SNMP over TCP

You can enable a one-time authentication for SNMP over a TCP session.

Command	Purpose
switch(config)# snmp-server tcp-session [auth]	Enables a one-time authentication for SNMP over a TCP session. This feature is disabled by default.

Assigning SNMP Switch Contact and Location Information

You can assign the switch contact information, which is limited to 32 characters (without spaces), and the switch location.

SUMMARY STEPS

1. switch# **configuration terminal**
2. switch(config)# **snmp-server contact** *name*
3. switch(config)# **snmp-server location** *name*
4. (Optional) switch# **show snmp**
5. (Optional) switch# **copy running-config startup-config**

DETAILED STEPS

	Command or Action	Purpose
Step 1	switch# configuration terminal	Enters global configuration mode.
Step 2	switch(config)# snmp-server contact <i>name</i>	Configures sysContact, the SNMP contact name.
Step 3	switch(config)# snmp-server location <i>name</i>	Configures sysLocation, the SNMP location.
Step 4	(Optional) switch# show snmp	Displays information about one or more destination profiles.
Step 5	(Optional) switch# copy running-config startup-config	Saves this configuration change.

Configuring the Context to Network Entity Mapping

You can configure an SNMP context to map to a logical network entity, such as a protocol instance or VRF.

SUMMARY STEPS

1. switch# **configuration terminal**

2. switch(config)# **snmp-server context** *context-name* [**instance** *instance-name*] [**vrf** *vrf-name*] [**topology** *topology-name*]
3. switch(config)# **snmp-server mib community-map** *community-name* **context** *context-name*
4. (Optional) switch(config)# **no snmp-server context** *context-name* [**instance** *instance-name*] [**vrf** *vrf-name*] [**topology** *topology-name*]

DETAILED STEPS

	Command or Action	Purpose
Step 1	switch# configuration terminal	Enters global configuration mode.
Step 2	switch(config)# snmp-server context <i>context-name</i> [instance <i>instance-name</i>] [vrf <i>vrf-name</i>] [topology <i>topology-name</i>]	Maps an SNMP context to a protocol instance, VRF, or topology. The names can be any alphanumeric string up to 32 characters.
Step 3	switch(config)# snmp-server mib community-map <i>community-name</i> context <i>context-name</i>	Maps an SNMPv2c community to an SNMP context. The names can be any alphanumeric string up to 32 characters.
Step 4	(Optional) switch(config)# no snmp-server context <i>context-name</i> [instance <i>instance-name</i>] [vrf <i>vrf-name</i>] [topology <i>topology-name</i>]	Deletes the mapping between an SNMP context and a protocol instance, VRF, or topology. The names can be any alphanumeric string up to 32 characters. Note Do not enter an instance, VRF, or topology to delete a context mapping. If you use the instance , vrf , or topology keywords, you configure a mapping between the context and a zero-length string.

Disabling SNMP

SUMMARY STEPS

1. **configure terminal**
2. switch(config) # **no snmp-server protocol enable**

DETAILED STEPS

	Command or Action	Purpose
Step 1	configure terminal Example: switch# configure terminal switch(config)#	Enters global configuration mode.
Step 2	switch(config) # no snmp-server protocol enable Example: no snmp-server protocol enable	Disables SNMP. SNMP is disabled by default.

Verifying the SNMP Configuration

To display SNMP configuration information, perform one of the following tasks:

Command	Purpose
<code>show snmp</code>	Displays the SNMP status.
<code>show snmp community</code>	Displays the SNMP community strings.
<code>show snmp engineID</code>	Displays the SNMP engineID.
<code>show snmp group</code>	Displays SNMP roles.
<code>show snmp sessions</code>	Displays SNMP sessions.
<code>show snmp trap</code>	Displays the SNMP notifications enabled or disabled.
<code>show snmp user</code>	Displays SNMPv3 users.

Additional References

MIBs

MIBs	MIBs Link
MIBs related to SNMP	To locate and download supported MIBs, go to the following https://cisco.github.io/cisco-mibs/supportlists/nexus3548/Nexus3548MIBSupportList.html



CHAPTER 10

Configuring RMON

This chapter contains the following sections:

- [Information About RMON, on page 117](#)
- [Configuration Guidelines and Limitations for RMON, on page 118](#)
- [Configuring RMON, on page 118](#)
- [Verifying the RMON Configuration, on page 120](#)
- [Default RMON Settings, on page 121](#)

Information About RMON

RMON is an Internet Engineering Task Force (IETF) standard monitoring specification that allows various network agents and console systems to exchange network monitoring data. The Cisco NX-OS supports RMON alarms, events, and logs to monitor Cisco Nexus device.

An RMON alarm monitors a specific management information base (MIB) object for a specified interval, triggers an alarm at a specified threshold value (threshold), and resets the alarm at another threshold value. You can use alarms with RMON events to generate a log entry or an SNMP notification when the RMON alarm triggers.

RMON is disabled by default and no events or alarms are configured in Cisco Nexus devices. You can configure your RMON alarms and events by using the CLI or an SNMP-compatible network management station.

RMON Alarms

You can set an alarm on any MIB object that resolves into an SNMP INTEGER type. The specified object must be an existing SNMP MIB object in standard dot notation (for example, 1.3.6.1.2.1.2.2.1.17 represents ifOutOctets.17).

When you create an alarm, you specify the following parameters:

- MIB object to monitor
- Sampling interval—The interval that the Cisco Nexus device uses to collect a sample value of the MIB object.
- Sample type—Absolute samples take the current snapshot of the MIB object value. Delta samples take two consecutive samples and calculate the difference between them.

- Rising threshold—The value at which the Cisco Nexus device triggers a rising alarm or resets a falling alarm.
- Falling threshold—The value at which the Cisco Nexus device triggers a falling alarm or resets a rising alarm.
- Events—The action that the Cisco Nexus device takes when an alarm (rising or falling) triggers.



Note Use the `hcalarms` option to set an alarm on a 64-bit integer MIB object.

For example, you can set a delta type rising alarm on an error counter MIB object. If the error counter delta exceeds this value, you can trigger an event that sends an SNMP notification and logs the rising alarm event. This rising alarm does not occur again until the delta sample for the error counter drops below the falling threshold.



Note The falling threshold must be less than the rising threshold.

RMON Events

You can associate a particular event to each RMON alarm. RMON supports the following event types:

- SNMP notification—Sends an SNMP risingAlarm or fallingAlarm notification when the associated alarm triggers.
- Log—Adds an entry in the RMON log table when the associated alarm triggers.
- Both—Sends an SNMP notification and adds an entry in the RMON log table when the associated alarm triggers.

You can specify a different even for a falling alarm and a rising alarm.

Configuration Guidelines and Limitations for RMON

RMON has the following configuration guidelines and limitations:

- You must configure an SNMP user and a notification receiver to use the SNMP notification event type.
- You can only configure an RMON alarm on a MIB object that resolves to an integer.

Configuring RMON

Configuring RMON Alarms

You can configure RMON alarms on any integer-based SNMP MIB object.

You can optionally specify the following parameters:

- The eventnumber to trigger if the rising or falling threshold exceeds the specified limit.
- The owner of the alarm.

Ensure you have configured an SNMP user and enabled SNMP notifications.

Before you begin

Ensure you have configured an SNMP user and enabled SNMP notifications.

SUMMARY STEPS

1. switch# **configure terminal**
2. switch(config)# **rmon alarm** *index mib-object sample-interval* {**absolute** | **delta**} **rising-threshold** *value* [*event-index*] **falling-threshold** *value* [*event-index*] [**owner name**]
3. switch(config)# **rmon hcalarm** *index mib-object sample-interval* {**absolute** | **delta**} **rising-threshold-high** *value* **rising-threshold-low** *value* [*event-index*] **falling-threshold-high** *value* **falling-threshold-low** *value* [*event-index*] [**owner name**] [**storagetype** *type*]
4. (Optional) switch# **show rmon** {**alarms** | **hcalarms**}
5. (Optional) switch# **copy running-config startup-config**

DETAILED STEPS

	Command or Action	Purpose
Step 1	switch# configure terminal	Enters global configuration mode.
Step 2	switch(config)# rmon alarm <i>index mib-object sample-interval</i> { absolute delta } rising-threshold <i>value</i> [<i>event-index</i>] falling-threshold <i>value</i> [<i>event-index</i>] [owner name]	Creates an RMON alarm. The value range is from –2147483647 to 2147483647. The owner name can be any alphanumeric string.
Step 3	switch(config)# rmon hcalarm <i>index mib-object sample-interval</i> { absolute delta } rising-threshold-high <i>value</i> rising-threshold-low <i>value</i> [<i>event-index</i>] falling-threshold-high <i>value</i> falling-threshold-low <i>value</i> [<i>event-index</i>] [owner name] [storagetype <i>type</i>]	Creates an RMON high-capacity alarm. The value range is from –2147483647 to 2147483647. The owner name can be any alphanumeric string. The storage type range is from 1 to 5.
Step 4	(Optional) switch# show rmon { alarms hcalarms }	Displays information about RMON alarms or high-capacity alarms.
Step 5	(Optional) switch# copy running-config startup-config	Saves this configuration change.

Example

The following example shows how to configure RMON alarms:

```
switch# configure terminal
switch(config)# rmon alarm 1 1.3.6.1.2.1.2.2.1.17.83886080 5 delta rising-threshold 5 1
falling-threshold 0 owner test
switch(config)# exit
```

```
switch# show rmon alarms
Alarm 1 is active, owned by test
Monitors 1.3.6.1.2.1.2.2.1.17.83886080 every 5 second(s)
Taking delta samples, last value was 0
Rising threshold is 5, assigned to event 1
Falling threshold is 0, assigned to event 0
On startup enable rising or falling alarm
```

Configuring RMON Events

You can configure RMON events to associate with RMON alarms. You can reuse the same event with multiple RMON alarms.

Ensure you have configured an SNMP user and enabled SNMP notifications.

Before you begin

Ensure that you have configured an SNMP user and enabled SNMP notifications.

SUMMARY STEPS

1. switch# **configure terminal**
2. switch(config)# **rmon event** *index* [**description string**] [**log**] [**trap**] [**owner name**]
3. (Optional) switch(config)# **show rmon** {**alarms** | **hcalarms**}
4. (Optional) switch# **copy running-config startup-config**

DETAILED STEPS

	Command or Action	Purpose
Step 1	switch# configure terminal	Enters global configuration mode.
Step 2	switch(config)# rmon event <i>index</i> [description string] [log] [trap] [owner name]	Configures an RMON event. The description string and owner name can be any alphanumeric string.
Step 3	(Optional) switch(config)# show rmon { alarms hcalarms }	Displays information about RMON alarms or high-capacity alarms.
Step 4	(Optional) switch# copy running-config startup-config	Saves this configuration change.

Verifying the RMON Configuration

Use the following commands to verify the RMON configuration information:

Command	Purpose
show rmon alarms	Displays information about RMON alarms.

Command	Purpose
<code>show rmon events</code>	Displays information about RMON events.
<code>show rmon hcalarms</code>	Displays information about RMON hcalarms.
<code>show rmon logs</code>	Displays information about RMON logs.

Default RMON Settings

The following table lists the default settings for RMON parameters.

Table 21: Default RMON Parameters

Parameters	Default
Alarms	None configured.
Events	None configured.



CHAPTER 11

Configuring Online Diagnostics

This chapter contains the following sections:

- [Information About Online Diagnostics, on page 123](#)
- [Configuring Online Diagnostics, on page 125](#)
- [Verifying the Online Diagnostics Configuration, on page 126](#)
- [Default Settings for Online Diagnostics, on page 126](#)

Information About Online Diagnostics

Online diagnostics provide verification of hardware components during switch bootup or reset, and they monitor the health of the hardware during normal switch operation.

Cisco Nexus Series switches support bootup diagnostics and runtime diagnostics. Bootup diagnostics include disruptive tests and nondisruptive tests that run during system bootup and system reset.

Runtime diagnostics (also known as health monitoring diagnostics) include nondisruptive tests that run in the background during normal operation of the switch.

Bootup Diagnostics

Bootup diagnostics detect faulty hardware before bringing the switch online. Bootup diagnostics also check the data path and control path connectivity between the supervisor and the ASICs. The following table describes the diagnostics that are run only during switch bootup or reset.

Table 22: Bootup Diagnostics

Diagnostic	Description
PCIe	Tests PCI express (PCIe) access.
NVRAM	Verifies the integrity of the NVRAM.
In band port	Tests connectivity of the inband port to the supervisor.
Management port	Tests the management port.
Memory	Verifies the integrity of the DRAM.

Bootup diagnostics also include a set of tests that are common with health monitoring diagnostics.

Bootup diagnostics log any failures to the onboard failure logging (OBFL) system. Failures also trigger an LED display to indicate diagnostic test states (on, off, pass, or fail).

You can configure Cisco Nexus device to either bypass the bootup diagnostics or run the complete set of bootup diagnostics.

Health Monitoring Diagnostics

Health monitoring diagnostics provide information about the health of the switch. They detect runtime hardware errors, memory errors, software faults, and resource exhaustion.

Health monitoring diagnostics are nondisruptive and run in the background to ensure the health of a switch that is processing live network traffic.

The following table describes the health monitoring diagnostics for the switch.

Table 23: Health Monitoring Diagnostics Tests

Diagnostic	Description
LED	Monitors port and system status LEDs.
Power Supply	Monitors the power supply health state.
Temperature Sensor	Monitors temperature sensor readings.
Test Fan	Monitors the fan speed and fan control.

The following table describes the health monitoring diagnostics that also run during system boot or system reset.

Table 24: Health Monitoring and Bootup Diagnostics Tests

Diagnostic	Description
SPROM	Verifies the integrity of backplane and supervisor SPROMs.
Fabric engine	Tests the switch fabric ASICs.
Fabric port	Tests the ports on the switch fabric ASIC.
Forwarding engine	Tests the forwarding engine ASICs.
Forwarding engine port	Tests the ports on the forwarding engine ASICs.
Front port	Tests the components (such as PHY and MAC) on the front ports.

Expansion Module Diagnostics

During the switch bootup or reset, the bootup diagnostics include tests for the in-service expansion modules in the switch.

When you insert an expansion module into a running switch, a set of diagnostics tests are run. The following table describes the bootup diagnostics for an expansion module. These tests are common with the bootup diagnostics. If the bootup diagnostics fail, the expansion module is not placed into service.

Table 25: Expansion Module Bootup and Health Monitoring Diagnostics

Diagnostic	Description
SPROM	Verifies the integrity of backplane and supervisor SPROMs.
Fabric engine	Tests the switch fabric ASICs.
Fabric port	Tests the ports on the switch fabric ASIC.
Forwarding engine	Tests the forwarding engine ASICs.
Forwarding engine port	Tests the ports on the forwarding engine ASICs.
Front port	Tests the components (such as PHY and MAC) on the front ports.

Health monitoring diagnostics are run on in-service expansion modules. The following table describes the additional tests that are specific to health monitoring diagnostics for expansion modules.

Table 26: Expansion Module Health Monitoring Diagnostics

Diagnostic	Description
LED	Monitors port and system status LEDs.
Temperature Sensor	Monitors temperature sensor readings.

Configuring Online Diagnostics

You can configure the bootup diagnostics to run the complete set of tests, or you can bypass all bootup diagnostic tests for a faster module boot up time.



Note We recommend that you set the bootup online diagnostics level to complete. We do not recommend bypassing the bootup online diagnostics.

SUMMARY STEPS

1. switch# **configure terminal**
2. switch(config)# **diagnostic bootup level [complete | bypass]**
3. (Optional) switch# **show diagnostic bootup level**

DETAILED STEPS

	Command or Action	Purpose
Step 1	switch# configure terminal	Enters global configuration mode.
Step 2	switch(config)# diagnostic bootup level [complete bypass]	Configures the bootup diagnostic level to trigger diagnostics when the device boots, as follows: <ul style="list-style-type: none"> • complete—Performs all bootup diagnostics. This is the default value. • bypass—Does not perform any bootup diagnostics.
Step 3	(Optional) switch# show diagnostic bootup level	Displays the bootup diagnostic level (bypass or complete) that is currently in place on the switch.

Example

The following example shows how to configure the bootup diagnostics level to trigger the complete diagnostics:

```
switch# configure terminal
switch(config)# diagnostic bootup level complete
```

Verifying the Online Diagnostics Configuration

Use the following commands to verify online diagnostics configuration information:

Command	Purpose
show diagnostic bootup level	Displays the bootup diagnostics level.
show diagnostic result module slot	Displays the results of the diagnostics tests.

Default Settings for Online Diagnostics

The following table lists the default settings for online diagnostics parameters.

Table 27: Default Online Diagnostics Parameters

Parameters	Default
Bootup diagnostics level	complete



CHAPTER 12

Configuring Embedded Event Manager

This chapter contains the following sections:

- [About Embedded Event Manager, on page 127](#)
- [Embedded Event Manager Policies, on page 128](#)
- [Prerequisites for Embedded Event Manager, on page 130](#)
- [Guidelines and Limitations for Embedded Event Manager, on page 130](#)
- [Default Settings for Embedded Event Manager, on page 131](#)
- [Defining an Environment Variable, on page 131](#)
- [Defining a User Policy Using the CLI, on page 132](#)
- [Configuring Event Statements, on page 134](#)
- [Configuring Action Statements, on page 136](#)
- [Defining a Policy Using a VSH Script, on page 138](#)
- [Registering and Activating a VSH Script Policy, on page 139](#)
- [Overriding a System Policy, on page 140](#)
- [Configuring Syslog as an EEM Publisher, on page 141](#)
- [Event Log Auto-Collection and Backup, on page 142](#)

About Embedded Event Manager

The ability to detect and handle critical events in the Cisco NX-OS system is important for high availability. The Embedded Event Manager (EEM) provides a central, policy-driven framework to detect and handle events in the system by monitoring events that occur on your device and taking action to recover or troubleshoot these events, based on your configuration..

EEM consists of three major components:

Event statements

Events to monitor from another Cisco NX-OS component that may require some action, workaround, or notification.

Action statements

An action that EEM can take, such as sending an e-mail or disabling an interface, to recover from an event.

Policies

An event paired with one or more actions to troubleshoot or recover from the event.

Without EEM, each individual component is responsible for detecting and handling its own events. For example, if a port flaps frequently, the policy of "putting it into errDisable state" is built into ETHPM.

Embedded Event Manager Policies

An EEM policy consists of an event statement and one or more action statements. The event statement defines the event to look for as well as the filtering characteristics for the event. The action statement defines the action EEM takes when the event occurs.

For example, you can configure an EEM policy to identify when a card is removed from the device and log the details related to the card removal. By setting up an event statement that tells the system to look for all instances of card removal and an then with an action statement that tells the system to log the details.

You can configure EEM policies using the command line interface (CLI) or a VSH script.

EEM gives you a device-wide view of policy management. Once EEM policies are configured, the corresponding actions are triggered. All actions (system or user-configured) for triggered events are tracked and maintained by the system.

Preconfigured System Policies

Cisco NX-OS has a number of preconfigured system policies. These system policies define many common events and actions for the device. System policy names begin with two underscore characters (__).

Some system policies can be overridden. In these cases, you can configure overrides for either the event or the action. The overrides that you configure take the place of the system policy.



Note Override policies must include an event statement. Override policies without event statements override all possible events for the system policy.

To view the preconfigured system polices and determine which polices you can override, use the **show event manager system-policy** command.

User-Created Policies

User-created policies allow you to customize EEM policies for your network. If a user policy is created for an event, actions in the policy are triggered only after EEM triggers the system policy actions related to the same event.

Log Files

The log file that contains data that is related to EEM policy matches is maintained in the event_archive_1 log file located in the /log/event_archive_1 directory.

Event Statements

Any device activity for which some action, such as a workaround or notification, is taken is considered an event by EEM. In many cases, events are related to faults in the device, such as when an interface or a fan malfunctions.

Event statements specify which event or events triggers a policy to run.



Tip You can configure EEM to trigger an EEM policy that is based on a combination of events by creating and differentiating multiple EEM events in the policy and then defining a combination of events to trigger a custom action.

EEM defines event filters so that only critical events or multiple occurrences of an event within a specified time period trigger an associated action.

Some commands or internal events trigger other commands internally. These commands are not visible, but will still match the event specification that triggers an action. You cannot prevent these commands from triggering an action, but you can check which event triggered an action.

Supported Events

EEM supports the following events in event statements:

- Counter events
- Fan absent events
- Fan bad events
- Memory thresholds events
- Events being used in overridden system policies.
- SNMP notification events
- Syslog events
- System manager events
- Temperature events
- Track events

Action Statements

Action statements describe the action that is triggered by a policy when an event occurs. Each policy can have multiple action statements. If no action is associated with a policy, EEM still observes events but takes no actions.

In order for triggered events to process default actions, you must configure the EEM policy to allow the default action. For example, if you match a CLI command in a match statement, you must add the event-default action statement to the EEM policy or EEM does not allow the command to execute.



Note When configuring action statements within your user policy or overriding policy, it is important that you confirm that action statements do not negate each other or adversely affect the associated system policy.

Supported Actions

EEM supports the following actions in action statements:

- Execute any CLI commands
- Update a counter
- Reload the device
- Generate a syslog message
- Generate an SNMP notification
- Use the default action for the system policy

VSH Script Policies

You can write policies in a VSH script, by using a text editor. Policies that are written using a VSH script have an event statement and action statement(s) just as other policies, and these policies can either augment or override system policies.

After you define your VSH script policy, copy it to the device and activate it.

Prerequisites for Embedded Event Manager

You must have network-admin privileges to configure EEM.

Guidelines and Limitations for Embedded Event Manager

When you plan your EEM configuration, consider the following:

- The maximum number of configurable EEM policies is 500.
- Action statements within your user policy or overriding policy should not negate each other or adversely affect the associated system policy.
- To allow a triggered event to process any default actions, you must configure the EEM policy to allow the default action. For example, if you match a command in a match statement, you must add the event-default action statement to the EEM policy or EEM does not allow the command to execute.
- The following guidelines apply to Event Log Auto-Collection and Backup:
 - By default, enabled log collection on a switch provides between 15 minutes to several hours of event logs depending on size, scale and component activity.
 - To be able to collect relevant logs that span a longer period, only enable event log retention for the specific services/features you need. See "Enabling Extended Log File Retention For a Single Service". You can also export the internal event logs. See "External Log File Storage".
 - When troubleshooting, it is good practice to manually collect a snapshot of internal event logs in real time. See "Generating a Local Copy of Recent Log Files".
- An override policy that consists of an event statement and no action statement triggers no action and no notification of failures.
- An override policy without an event statement overrides all possible events in the system policy.

- In regular command expressions: all keywords must be expanded, and only the asterisk (*) symbol can be used for replace the arguments.
- EEM event correlation supports up to four event statements in a single policy. The event types can be the same or different, but only these event types are supported: cli, counter, snmp, syslog, and track.
- When more than one event statement is included in an EEM policy, each event statement must have a **tag** keyword with a unique tag argument.
- EEM event correlation does not override the system default policies.
- Default action execution is not supported for policies that are configured with tagged events.
- If your event specification matches a CLI pattern, you can use SSH-style wild card characters.
For example, if you want to match all show commands, enter the **show *** command. Entering the **show .*** command does not work.
- If your event specification is a regular expression for a matching syslog message, you can use a proper regular expression.
For example, if you want to detect ADMIN_DOWN events on any port where a syslog is generated, use **.ADMIN_DOWN..** Entering the **ADMIN_DOWN** command does not work.
- In the event specification for a syslog, the regex does not match any syslog message that is generated as an action of an EEM policy.
- If an EEM event matches a **show** command in the CLI and you want the output for that **show** command to display on the screen (and to not be blocked by the EEM policy), you must specify the **event-default** command for the first action for the EEM policy.
- Cisco Nexus 3500 Series switches do not support Embedded Event Manager in Cisco NX-OS Release 7.0(3)I7(2) and the previous releases.

Default Settings for Embedded Event Manager

Table 28: Default EEM Parameters

Parameters	Default
System Policies	Active

Defining an Environment Variable

Defining an environment variable is an optional step but is useful for configuring common values for repeated use in multiple policies.

SUMMARY STEPS

1. **configure terminal**
2. **event manager environment** *variable-name variable-value*
3. (Optional) **show event manager environment** {*variable-name* | **all**}

4. (Optional) **copy running-config startup-config**

DETAILED STEPS

	Command or Action	Purpose
Step 1	configure terminal Example: switch# configure terminal switch(config)#	Enters global configuration mode.
Step 2	event manager environment <i>variable-name variable-value</i> Example: switch(config) # event manager environment emailto "admin@anyplace.com"	Creates an environment variable for EEM. The <i>variable-name</i> can be any case-sensitive, alphanumeric string up to 29 characters. The <i>variable-value</i> can be any quoted case-sensitive, alphanumeric string up to 39 characters.
Step 3	(Optional) show event manager environment { <i>variable-name</i> all } Example: switch(config) # show event manager environment all	Displays information about the configured environment variables.
Step 4	(Optional) copy running-config startup-config Example: switch(config)# copy running-config startup-config	Saves the change persistently through reboots and restarts by copying the running configuration to the startup configuration.

What to do next

Configure a User Policy.

Defining a User Policy Using the CLI

SUMMARY STEPS

1. **configure terminal**
2. **event manager applet** *applet-name*
3. (Optional) **description** *policy-description*
4. **event** *event-statement*
5. (Optional) **tag** *tag* {**and** | **andnot** | **or**} *tag* [**and** | **andnot** | **or** {*tag*}] {**happens** *occurs in seconds*}
6. **action** *number*[.*number2*] *action-statement*
7. (Optional) **show event manager policy-state** *name* [**module** *module-id*]
8. (Optional) **copy running-config startup-config**

DETAILED STEPS

	Command or Action	Purpose
Step 1	configure terminal Example: switch# configure terminal switch(config)#	Enters global configuration mode.
Step 2	event manager applet <i>applet-name</i> Example: switch(config)# event manager applet monitorShutdown switch(config-applet)#	Registers the applet with EEM and enters applet configuration mode. The applet-name can be any case-sensitive, alphanumeric string up to 29 characters.
Step 3	(Optional) description <i>policy-description</i> Example: switch(config-applet)# description "Monitors interface shutdown."	Configures a descriptive string for the policy. The string can be any alphanumeric string up to 80 characters. Enclose the string in quotation marks.
Step 4	event <i>event-statement</i> Example: switch(config-applet)# event cli match "shutdown"	Configures the event statement for the policy.
Step 5	(Optional) tag <i>tag</i> { and andnot or } <i>tag</i> [and andnot or { <i>tag</i> }] { happens occurs in seconds } Example: switch(config-applet)# tag one or two happens 1 in 10000	Correlates multiple events in the policy. The range for the <i>occurs</i> argument is from 1 to 4294967295. The range for the <i>seconds</i> argument is from 0 to 4294967295 seconds.
Step 6	action <i>number</i> [. <i>number2</i>] <i>action-statement</i> Example: switch(config-applet)# action 1.0 cli show interface e 3/1	Configures an action statement for the policy. Repeat this step for multiple action statements.
Step 7	(Optional) show event manager policy-state <i>name</i> [module <i>module-id</i>] Example: switch(config-applet)# show event manager policy-state monitorShutdown	Displays information about the status of the configured policy.
Step 8	(Optional) copy running-config startup-config Example: switch(config)# copy running-config startup-config	Saves the change persistently through reboots and restarts by copying the running configuration to the startup configuration.

What to do next

Configure event statements and action statements.

Configuring Event Statements

Use one of the following commands in EEM configuration mode (config-applet) to configure an event statement:

Before you begin

Define a user policy.

SUMMARY STEPS

1. **event cli** [*tag tag*] **match** *expression* [**count** *repeats* | **time** *seconds*]
2. **event counter** [*tag tag*] **name** *counter* **entry-val** *entry* **entry-op** {**eq** | **ge** | **gt** | **le** | **lt** | **ne**} {**exit-val** *exit* **exit-op** {**eq** | **ge** | **gt** | **le** | **lt** | **ne**}}
3. **event fanabsent** [**fan** *number*] **time** *seconds*
4. **event fanbad** [**fan** *number*] **time** *seconds*
5. **event memory** {**critical** | **minor** | **severe**}
6. **event policy-default** **count** *repeats* [**time** *seconds*]
7. **event snmp** [*tag tag*] **oid** *oid* **get-type** {**exact** | **next**} **entry-op** {**eq** | **ge** | **gt** | **le** | **lt** | **ne**} **entry-val** *entry* [**exit-comb** {**and** | **or**}] **exit-op** {**eq** | **ge** | **gt** | **le** | **lt** | **ne**} **exit-val** *exit* **exit-time** *time* **polling-interval** *interval*
8. **event sysmgr** **memory** [**module** *module-num*] **major** *major-percent* **minor** *minor-percent* **clear** *clear-percent*
9. **event temperature** [**module** *slot*] [**sensor** *number*] **threshold** {**any** | **down** | **up**}
10. **event track** [*tag tag*] **object-number** *state* {**any** | **down** | **up**}

DETAILED STEPS

	Command or Action	Purpose
Step 1	event cli [<i>tag tag</i>] match <i>expression</i> [count <i>repeats</i> time <i>seconds</i>] Example: <pre>switch(config-applet) # event cli match "shutdown"</pre>	Triggers an event if you enter a command that matches the regular expression. The tag tag keyword-argument pair identifies this specific event when multiple events are included in the policy. The <i>repeats</i> range is from 1 to 65000. The <i>time</i> range is from 0 to 4294967295, where 0 indicates no time limit.
Step 2	event counter [<i>tag tag</i>] name <i>counter</i> entry-val <i>entry</i> entry-op { eq ge gt le lt ne } { exit-val <i>exit</i> exit-op { eq ge gt le lt ne }} Example: <pre>switch(config-applet) # event counter name mycounter entry-val 20 gt</pre>	Triggers an event if the counter crosses the entry threshold based on the entry operation. The event resets immediately. Optionally, you can configure the event to reset after the counter passes the exit threshold. The tag tag keyword-argument pair identifies this specific event when multiple events are included in the policy. The <i>counter</i> name can be any case-sensitive, alphanumeric string up to 28 characters.

	Command or Action	Purpose
		The <i>entry</i> and <i>exit</i> value ranges are from 0 to 2147483647.
Step 3	event fanabsent [<i>fan number</i>] time <i>seconds</i> Example: <pre>switch(config-applet) # event fanabsent time 300</pre>	Triggers an event if a fan is removed from the device for more than the configured time, in seconds. The <i>number</i> range is from 1 to 1 and is module-dependent. The <i>seconds</i> range is from 10 to 64000.
Step 4	event fanbad [<i>fan number</i>] time <i>seconds</i> Example: <pre>switch(config-applet) # event fanbad time 3000</pre>	Triggers an event if a fan fails for more than the configured time, in seconds. The <i>number</i> range is module-dependent. The <i>seconds</i> range is from 10 to 64000.
Step 5	event memory { <i>critical</i> <i>minor</i> <i>severe</i> } Example: <pre>switch(config-applet) # event memory critical</pre>	Triggers an event if a memory threshold is crossed.
Step 6	event policy-default count <i>repeats</i> [time <i>seconds</i>] Example: <pre>switch(config-applet) # event policy-default count 3</pre>	Uses the event configured in the system policy. Use this option for overriding policies. The <i>repeats</i> range is from 1 to 65000. The <i>seconds</i> range is from 0 to 4294967295, where 0 indicates no time limit.
Step 7	event snmp [<i>tag tag</i>] oid <i>oid</i> get-type { <i>exact</i> <i>next</i> } entry-op { <i>eq</i> <i>ge</i> <i>gt</i> <i>le</i> <i>lt</i> <i>ne</i> } entry-val <i>entry</i> [exit-comb {and or}]exit-op { <i>eq</i> <i>ge</i> <i>gt</i> <i>le</i> <i>lt</i> <i>ne</i> } exit-val <i>exit</i> exit-time <i>time</i> polling-interval <i>interval</i> Example: <pre>switch(config-applet) # event snmp oid 1.3.6.1.2.1.31.1.1.1.6 get-type next entry-op lt 300 entry-val 0 exit-op eq 400 exit-time 30 polling-interval 300</pre>	Triggers an event if the SNMP OID crosses the entry threshold based on the entry operation. The event resets immediately, or optionally you can configure the event to reset after the counter passes the exit threshold. The OID is in dotted decimal notation. The tag tag keyword-argument pair identifies this specific event when multiple events are included in the policy. The <i>entry</i> and <i>exit</i> value ranges are from 0 to 18446744073709551615. The <i>time</i> , in seconds, is from 0 to 2147483647. The <i>interval</i> , in seconds, is from 0 to 2147483647.
Step 8	event sysmgr memory [<i>module module-num</i>] major <i>major-percent</i> minor <i>minor-percent</i> clear <i>clear-percent</i> Example: <pre>switch(config-applet) # event sysmgr memory minor 80</pre>	Triggers an event if the specified system manager memory threshold is exceeded. The <i>percent</i> range is from 1 to 99.
Step 9	event temperature [<i>module slot</i>] [<i>sensor number</i>] threshold { <i>any</i> <i>down</i> <i>up</i> } Example:	Triggers an event if the temperature sensor exceeds the configured threshold. The <i>sensor</i> range is from 1 to 18.

	Command or Action	Purpose
	<pre>switch(config-applet) # event temperature module 2 threshold any</pre>	
Step 10	<p>event track [tag tag] <i>object-number</i> state {any down up}</p> <p>Example:</p> <pre>switch(config-applet) # event track 1 state down</pre>	<p>Triggers an event if the tracked object is in the configured state.</p> <p>The tag tag keyword-argument pair identifies this specific event when multiple events are included in the policy.</p> <p>The <i>object-number</i> range is from 1 to 500.</p>

What to do next

Configure action statements.

If you have already configured action statements or choose not to, complete any of the optional tasks:

- Define a policy using a VSH script. Then, register and activate a VSH script policy.
- Configure memory thresholds
- Configure the syslog as an EEM publisher.
- Verify your EEM configuration.

Configuring Action Statements

You can configure an action by using one of the following commands in EEM configuration mode (config-applet):



Note If you want to allow a triggered event to process any default actions, you must configure the EEM policy to allow the default action. For example, if you match a command in a match statement, you must add the event-default action statement to the EEM policy or EEM does not allow the command to execute. You can use the **terminal event-manager bypass** command to allow all EEM policies with matches to execute the command.

Before you begin

Define a user policy.

SUMMARY STEPS

1. **action** *number*[.*number2*] **cli** *command1*[*command2*.] [**local**]
2. **action** *number*[.*number2*] **counter** *name* *counter* *value* *val* **op** {**dec** | **inc** | **nop** | **set**}
3. **action** *number*[.*number2*] **event-default**
4. **action** *number*[.*number2*] **policy-default**
5. **action** *number*[.*number2*] **reload** [**module** *slot* [- *slot*]]
6. **action** *number*[.*number2*] **snmp-trap** [**intdata1** *integer-data1*] [**intdata2** *integer-data2*] [**strdata** *string-data*]

7. action number[.number2] syslog [priority prio-val] msg error-message

DETAILED STEPS

	Command or Action	Purpose
Step 1	action number[.number2] cli command1[command2.] [local] Example: <pre>switch(config-applet) # action 1.0 cli "show interface e 3/1"</pre>	Runs the configured commands. You can optionally run the commands on the module where the event occurred. The action label is in the format number1.number2. The <i>number</i> can be any number from 1 to 16 digits. The range for <i>number2</i> is from 0 to 9.
Step 2	action number[.number2] counter name counter value val op {dec inc nop set} Example: <pre>switch(config-applet) # action 2.0 counter name mycounter value 20 op inc</pre>	Modifies the counter by the configured value and operation. The action label is in the format number1.number2. The <i>number</i> can be any number from 1 to 16 digits. The range for <i>number2</i> is from 0 to 9. The <i>counter</i> can be any case-sensitive, alphanumeric string up to 28 characters. The <i>val</i> can be an integer from 0 to 2147483647 or a substituted parameter.
Step 3	action number[.number2] event-default Example: <pre>switch(config-applet) # action 1.0 event-default</pre>	Completes the default action for the associated event. The action label is in the format number1.number2. The <i>number</i> can be any number from 1 to 16 digits. The range for <i>number2</i> is from 0 to 9.
Step 4	action number[.number2] policy-default Example: <pre>switch(config-applet) # action 1.0 policy-default</pre>	Completes the default action for the policy that you are overriding. The action label is in the format number1.number2. The <i>number</i> can be any number from 1 to 16 digits. The range for <i>number2</i> is from 0 to 9.
Step 5	action number[.number2] reload [module slot [- slot]] Example: <pre>switch(config-applet) # action 1.0 reload module 3-5</pre>	Forces one or more modules to the entire system to reload. The action label is in the format number1.number2. The <i>number</i> can be any number from 1 to 16 digits. The range for <i>number2</i> is from 0 to 9.
Step 6	action number[.number2] snmp-trap [intdata1 integer-data1] [intdata2 integer-data2] [strdata string-data] Example: <pre>switch(config-applet) # action 1.0 snmp-trap strdata "temperature problem"</pre>	Sends an SNMP trap with the configured data. The action label is in the format number1.number2. The <i>number</i> can be any number from 1 to 16 digits. The range for <i>number2</i> is from 0 to 9. The <i>data</i> elements can be any number up to 80 digits.

	Command or Action	Purpose
		The <i>string</i> can be any alphanumeric string up to 80 characters.
Step 7	action <i>number</i> [<i>number2</i>] syslog [priority <i>prio-val</i>] msg <i>error-message</i> Example: <pre>switch(config-applet) # action 1.0 syslog priority notifications msg "cpu high"</pre>	Sends a customized syslog message at the configured priority. The action label is in the format <i>number1.number2</i> . The <i>number</i> can be any number from 1 to 16 digits. The range for <i>number2</i> is from 0 to 9. The <i>error-message</i> can be any quoted alphanumeric string up to 80 characters.

What to do next

Configure event statements.

If you have already configured event statements or choose not to, complete any of the optional tasks:

- Define a policy using a VSH script. Then, register and activate a VSH script policy.
- Configure memory thresholds
- Configure the syslog as an EEM publisher.
- Verify your EEM configuration.

Defining a Policy Using a VSH Script

This is an optional task. Complete the following steps if you are using a VSH script to write EEM policies:

SUMMARY STEPS

1. In a text editor, list the commands that define the policy.
2. Name the text file and save it.
3. Copy the file to the following system directory: `bootflash://eem/user_script_policies`

DETAILED STEPS

-
- Step 1** In a text editor, list the commands that define the policy.
- Step 2** Name the text file and save it.
- Step 3** Copy the file to the following system directory: `bootflash://eem/user_script_policies`
-

What to do next

Register and activate a VSH script policy.

Registering and Activating a VSH Script Policy

This is an optional task. Complete the following steps if you are using a VSH script to write EEM policies.

Before you begin

Define a policy using a VSH script and copy the file to the system directory.

SUMMARY STEPS

1. **configure terminal**
2. **event manager policy *policy-script***
3. (Optional) **event manager policy internal *name***
4. (Optional) **copy running-config startup-config**

DETAILED STEPS

	Command or Action	Purpose
Step 1	configure terminal Example: <pre>switch# configure terminal switch(config)#</pre>	Enters global configuration mode.
Step 2	event manager policy <i>policy-script</i> Example: <pre>switch(config)# event manager policy moduleScript</pre>	Registers and activates an EEM script policy. The <i>policy-script</i> can be any case-sensitive, alphanumeric string up to 29 characters.
Step 3	(Optional) event manager policy internal <i>name</i> Example: <pre>switch(config)# event manager policy internal moduleScript</pre>	Registers and activates an EEM script policy. The <i>policy-script</i> can be any case-sensitive alphanumeric string up to 29 characters.
Step 4	(Optional) copy running-config startup-config Example: <pre>switch(config)# copy running-config startup-config</pre>	Saves the change persistently through reboots and restarts by copying the running configuration to the startup configuration.

What to do next

Complete any of the following, depending on your system requirements:

- Configure memory thresholds.
- Configure the syslog as an EEM publisher.
- Verify your EEM configuration.

Overriding a System Policy

SUMMARY STEPS

1. **configure terminal**
2. (Optional) **show event manager policy-state** *system-policy*
3. **event manager applet** *applet-name* **override** *system-policy*
4. **description** *policy-description*
5. **event** *event-statement*
6. **section** *number* *action-statement*
7. (Optional) **show event manager policy-state** *name*
8. (Optional) **copy running-config startup-config**

DETAILED STEPS

	Command or Action	Purpose
Step 1	configure terminal Example: <pre>switch# configure terminal switch(config)#</pre>	Enters global configuration mode.
Step 2	(Optional) show event manager policy-state <i>system-policy</i> Example: <pre>switch(config-applet)# show event manager policy-state __ethpm_link_flap Policy __ethpm_link_flap Cfg count : 5 Cfg time interval : 10.000000 (seconds) Hash default, Count 0</pre>	Displays information about the system policy that you want to override, including thresholds. Use the show event manager system-policy command to find the system policy names.
Step 3	event manager applet <i>applet-name</i> override <i>system-policy</i> Example: <pre>switch(config-applet)# event manager applet ethport override __ethpm_link_flap switch(config-applet)#</pre>	Overrides a system policy and enters applet configuration mode. The <i>applet-name</i> can be any case-sensitive, alphanumeric string up to 80 characters. The <i>system-policy</i> must be one of the system policies.
Step 4	description <i>policy-description</i> Example: <pre>switch(config-applet)# description "Overrides link flap policy"</pre>	Configures a descriptive string for the policy. The <i>policy-description</i> can be any case-sensitive, alphanumeric string up to 80 characters, but it must be enclosed in quotation marks.
Step 5	event <i>event-statement</i> Example: <pre>switch(config-applet)# event policy-default count 2 time 1000</pre>	Configures the event statement for the policy.

	Command or Action	Purpose
Step 6	section <i>number action-statement</i> Example: <pre>switch(config-applet)# action 1.0 syslog priority warnings msg "Link is flapping."</pre>	Configures an action statement for the policy. For multiple action statements, repeat this step.
Step 7	(Optional) show event manager policy-state <i>name</i> Example: <pre>switch(config-applet)# show event manager policy-state ethport</pre>	Displays information about the configured policy.
Step 8	(Optional) copy running-config startup-config Example: <pre>switch(config)# copy running-config startup-config</pre>	Saves the change persistently through reboots and restarts by copying the running configuration to the startup configuration.

Configuring Syslog as an EEM Publisher

Configuring syslog as an EEM publisher allows you to monitor syslog messages from the switch.



Note The maximum number of searchable strings to monitor syslog messages is 10.

Before you begin

- Confirm that EEM is available for registration by the syslog.
- Confirm that the syslog daemon is configured and executed.

SUMMARY STEPS

1. **configure terminal**
2. **event manager applet** *applet-name*
3. **event syslog** [**tag** *tag*] {**occurs** *number* | **period** *seconds* | **pattern** *msg-text* | **priority** *priority*}
4. (Optional) **copy running-config startup-config**

DETAILED STEPS

	Command or Action	Purpose
Step 1	configure terminal Example: <pre>switch# configure terminal switch(config)#</pre>	Enters global configuration mode.

	Command or Action	Purpose
Step 2	event manager applet <i>applet-name</i> Example: <pre>switch(config)# event manager applet abc switch (config-applet)#</pre>	Registers an applet with EEM and enters applet configuration mode.
Step 3	event syslog [tag <i>tag</i>] { occurs <i>number</i> period <i>seconds</i> pattern <i>msg-text</i> priority <i>priority</i> } Example: <pre>switch(config-applet)# event syslog occurs 10</pre>	Registers an applet with EEM and enters applet configuration mode.
Step 4	(Optional) copy running-config startup-config Example: <pre>switch(config)# copy running-config startup-config</pre>	Saves the change persistently through reboots and restarts by copying the running configuration to the startup configuration.

What to do next

Verify your EEM configuration.

Event Log Auto-Collection and Backup

Automatically collected event logs are stored locally on switch memory. Event log file storage is a temporary buffer that stores files for a fixed amount of time. Once the time period has elapsed, a roll-over of the buffer makes room for the next files. The roll-over uses a first-in-first-out method.

Beginning with Cisco NX-OS Release 9.3(3), EEM uses the following methods of collection and backup:

- Extended Log File Retention
- Trigger-Based Event Log Auto-Collection

Extended Log File Retention

Beginning with Cisco NX-OS release 9.3(3), all Cisco Nexus platform switches, with at least 8Gb of system memory, support the extended retention of event logging files. Storing the log files locally on the switch or remotely through an external container, reduces the loss of event logs due to rollover.

Enabling Extended Log File Retention For All Services

Extended Log File Retention is enabled by default for all services running on a switch. If the switch doesn't have the log file retention feature enabled (**no bloggerd log-dump** is configured), use the following procedure to enable it.

SUMMARY STEPS

1. **configure terminal**
2. **bloggerd log-dump all**

DETAILED STEPS

	Command or Action	Purpose
Step 1	configure terminal Example: <pre>switch# configure terminal switch(config)#</pre>	Enters global configuration mode.
Step 2	loggerd log-dump all Example: <pre>switch(config)# loggerd log-dump all switch(config)#</pre>	Enables the log file retention feature for all services.

Example

```
switch# configure terminal
switch(config)# loggerd log-dump all
Sending Enable Request to Loggerd
Loggerd Log Dump Successfully enabled
switch(config)#
```

Disabling Extended Log File Retention For All Services

Extended Log File Retention is disabled by default for all services on the switch. If the switch has the log file retention feature enabled for all services and you want to disable it, use the following procedure.

SUMMARY STEPS

1. **configure terminal**
2. **no loggerd log-dump all**

DETAILED STEPS

	Command or Action	Purpose
Step 1	configure terminal Example: <pre>switch# configure terminal switch(config)#</pre>	Enters global configuration mode.
Step 2	no loggerd log-dump all Example: <pre>switch(config)# no loggerd log-dump all switch(config)#</pre>	Disables the log file retention feature for all services on the switch.

Example

```
switch# configure terminal
switch(config)# no loggerd log-dump all
```

```

Sending Disable Request to Bloggerd
Bloggerd Log Dump Successfully disabled
switch(config)#

```

Enabling Extended Log File Retention For a Single Service

Extended Log File Retention is enabled by default for all services running on a switch. If the switch doesn't have the log file retention feature enabled (**no bloggerd log-dump** is configured), use the following procedure to enable it for a single service.

SUMMARY STEPS

1. **show system internal sysmgr service name** *service-type*
2. **configure terminal**
3. **bloggerd log-dump sap** *number*
4. **show system internal bloggerd info log-dump-info**

DETAILED STEPS

	Command or Action	Purpose
Step 1	show system internal sysmgr service name <i>service-type</i> Example: <pre>switch# show system internal sysmgr service name aclmgr</pre>	Displays information about the ACL Manager including the service SAP number.
Step 2	configure terminal Example: <pre>switch# configure terminal switch(config)#</pre>	Enters global configuration mode.
Step 3	bloggerd log-dump sap <i>number</i> Example: <pre>switch(config)# bloggerd log-dump sap 351</pre>	Enables the log file retention feature for the ACL Manager service.
Step 4	show system internal bloggerd info log-dump-info Example: <pre>switch(config)# show system internal bloggerd info log-dump-info</pre>	Displays information about the log file retention feature on the switch.

Example

```

switch# show system internal sysmgr service name aclmgr
Service "aclmgr" ("aclmgr", 80):
  UUID = 0x182, PID = 653, SAP = 351
  State: SRV_STATE_HANDSHAKED (entered at time Mon Nov  4 11:10:41 2019).
  Restart count: 1
  Time of last restart: Mon Nov  4 11:10:39 2019.
  The service never crashed since the last reboot.
  Tag = N/A

```



```

Plugin ID: 0
switch(config)# configure terminal
switch(config)# bloggerd log-dump sap 351
Sending Enable Request to Bloggerd
Bloggerd Log Dump Successfully enabled
switch(config)# show system internal bloggerd info log-dump-info
-----
Log Dump config is READY
Log Dump is DISABLED for ALL application services in the switch
Exceptions to the above rule (if any) are as follows:
-----
Module      | VDC      | SAP                               | Enabled?
-----
1           | 1        | 351 (MTS_SAP_ACLMGR              ) | Enabled
-----

Log Dump Throttle Switch-Wide Config:
-----
Log Dump Throttle                               : ENABLED
Minimum buffer rollover count (before throttling) : 5
Maximum allowed rollover count per minute         : 1
-----

switch(config)#

```

Displaying Extended Log Files

Use this task to display the event log files currently stored on the switch.

SUMMARY STEPS

1. `dir debug:log-dump/`

DETAILED STEPS

	Command or Action	Purpose
Step 1	dir debug:log-dump/ Example: switch# dir debug:log-dump/	Displays the event log files currently stored on the switch.

Example

```

switch# dir debug:log-dump/

3676160 Dec 05 02:43:01 2019 20191205023755_evtlog_archive.tar
3553280 Dec 05 06:05:06 2019 20191205060005_evtlog_archive.tar

Usage for debug://sup-local
913408 bytes used
4329472 bytes free
5242880 bytes total

```

Disabling Extended Log File Retention For a Single Service

Extended Log File Retention is enabled by default for all services on the switch. If the switch has the log file retention feature enabled for a single service or all services (by default in Cisco NX-OS Release 9.3(5)), and you want to disable a specific service or services, use the following procedure.

SUMMARY STEPS

1. **show system internal sysmgr service name *service-type***
2. **configure terminal**
3. **no bloggerd log-dump sap *number***
4. **show system internal bloggerd info log-dump-info**

DETAILED STEPS

	Command or Action	Purpose
Step 1	show system internal sysmgr service name <i>service-type</i> Example: <pre>switch# show system internal sysmgr service name aclmgr</pre>	Displays information about the ACL Manager including the service SAP number.
Step 2	configure terminal Example: <pre>switch# configure terminal switch(config)#</pre>	Enters global configuration mode.
Step 3	no bloggerd log-dump sap <i>number</i> Example: <pre>switch(config)# no bloggerd log-dump sap 351</pre>	Disables the log file retention feature for the ACL Manager service.
Step 4	show system internal bloggerd info log-dump-info Example: <pre>switch(config)# show system internal bloggerd info log-dump-info</pre>	Displays information about the log file retention feature on the switch.

Example

The following example shows how to disable extended log file retention for a service named "aclmgr":

```
switch# show system internal sysmgr service name aclmgr
Service "aclmgr" ("aclmgr", 80):
  UUID = 0x182, PID = 653, SAP = 351
  State: SRV_STATE_HANDSHAKED (entered at time Mon Nov  4 11:10:41 2019).
  Restart count: 1
  Time of last restart: Mon Nov  4 11:10:39 2019.
  The service never crashed since the last reboot.
  Tag = N/A
  Plugin ID: 0
switch(config)# configure terminal
switch(config)# no bloggerd log-dump sap 351
```

```

Sending Disable Request to Bloggerd
Bloggerd Log Dump Successfully disabled
switch(config)# show system internal bloggerd info log-dump-info
-----
Log Dump config is READY
Log Dump is DISABLED for ALL application services in the switch
Exceptions to the above rule (if any) are as follows:
-----
Module      | VDC      | SAP      | Enabled?
-----
1           | 1        | 351 (MTS_SAP_ACLMGR ) | Disabled
-----

Log Dump Throttle Switch-Wide Config:
-----
Log Dump Throttle                : ENABLED
Minimum buffer rollover count (before throttling) : 5
Maximum allowed rollover count per minute         : 1
-----

switch(config)#

```

Trigger-Based Event Log Auto-Collection

Trigger-based log collection capabilities:

- Automatically collect relevant data when issues occur.
- No impact on control plane
- Customizable configuration:
 - Defaults populated by Cisco
 - Selectively override what-to-collect by network administrator or by Cisco TAC.
 - Automatically update new triggers on image upgrades.
- Store logs locally on the switch or remotely on an external server.
- Supports severity 0, 1, and 2 syslogs:
- Custom syslogs for ad-hoc events (auto-collection commands attached to the syslogs)

Enabling Trigger-Based Log File Auto-Collection

To enable trigger-based automatic creation of log files, you must create an override policy for the `__syslog_trigger_default` system policy with a custom YAML file and define the specific logs for which information will be collected.

For more information on creating a custom YAML file to enable log file auto-collection, see [Configuring the Auto-Collection YAML File, on page 148](#).

Auto-Collection YAML File

The Auto-Collection YAML file that is specified in the **action** command in the EEM function, defines actions for different system or feature components. This file is located in the switch directory: `/bootflash/scripts`. In addition to the default YAML file, you can create component-specific YAML files and place them in the same

directory. The naming convention for component-specific YAML files is **component-name.yaml**. If a component-specific file is present in the same directory, it takes precedence over the file that is specified in the **action** command. For example, if the action file, **bootflash/scripts/platform.yaml** is in the **/bootflash/scripts** directory with the default action file, **bootflash/scripts/test.yaml**, then the instructions defined in **platform.yaml** file take precedence over the instructions for the platform component present in the default **test.yaml** file.

Examples of components are, ARP, BGP, IS-IS, and so on. If you are not familiar with all the component names, contact Cisco Customer Support for assistance in defining the YAML file for component-specific actions (and for the default **test.yaml** file as well).

Example:

```
event manager applet test_1 override __syslog_trigger_default
  action 1.0 collect test.yaml $_syslog_msg
```

Configuring the Auto-Collection YAML File

A contents of a YAML file determines the data collected during trigger-based auto-collection. There must be only one YAML file on the switch but it can contain auto-collection meta-data for any number of switch components and messages.

Locate the YAML file in the following directory on the switch:

```
/bootflash/scripts
```

Invoke the YAML file for trigger-based collection by using the following example. The example shows the minimum required configuration for trigger-based collection to work with a user-defined YAML file.

```
switch# show running-config eem
!Command: show running-config eem
!Running configuration last done at: Mon Sep 30 19:34:54 2019
!Time: Mon Sep 30 22:24:55 2019
version 9.3(3) Bios:version 07.59
event manager applet test_1 override __syslog_trigger_default
  action 1.0 collect test.yaml $_syslog_msg
```

In the preceding example, "test_1" is the name of the applet and "test.yaml" is the name of the user-configured YAML file present in the **/bootflash/scripts** directory.

Example YAML File

The following is an example of a basic YAML file supporting the trigger-based event log auto-collection feature. The definitions for the keys/values in the file are in the table that follows.



Note Make sure that the YMAL file has proper indentation. As a best practice, run it through any "online YAML validator" before using it on a switch.

```
bash-4.3$ cat /bootflash/scripts/test.yaml
version: 1
components:
  securityd:
    default:
      tech-sup: port
      commands: show module
  platform:
    default:
      tech-sup: port
```

```
commands: show module
```

Key: Value	Description
version: 1	Set to 1. Any other number creates an incompatibility for the auto collect script.
components:	Keyword specifying that what follows are switch components.
securityd:	Name of the syslog component (<code>securityd</code> is a facility name in syslog).
default:	Identifies all messages belonging to the component.
tech-sup: port	Collect tech support of the port module for the <code>securityd</code> syslog component.
commands: show module	Collect show module command output for the <code>securityd</code> syslog component.
platform:	Name of the syslog component (<code>platform</code> is a facility name in syslog).
tech-sup: port	Collect tech support of the port module for the <code>platform</code> syslog component.
commands: show module	Collect show module command output for the <code>platform</code> syslog component.

Use the following example to associate auto-collect metadata only for a specific log. For example, SECURITYD-2-FEATURE_ENABLE_DISABLE

```
securityd:
  feature_enable_disable:
    tech-sup: security
    commands: show module
```

Key: Value	Description
securityd:	Name of the syslog component (<code>securityd</code> is a facility name in syslog).
feature_enable_disable:	Message ID of the syslog message.
tech-sup: security	Collect tech support of the security module for the <code>securityd</code> syslog component.
commands: show module	Collect show module command output for the security syslog component.

Example syslog output for the above YAML entry:

```
2019 Dec 4 12:41:01 n9k-c93108tc-fx %SECURITYD-2-FEATURE_ENABLE_DISABLE: User
has enabled the feature bash-shell
```

Use the following example to specify multiple values.

```
version: 1
components:
  securityd:
    default:
      commands: show module;show version;show module
      tech-sup: port;lldp
```



Note Use semicolons to separate multiple show commands and tech support key values (see the preceding example).

Limiting the Amount of Auto-Collections Per Component

For auto-collection, the limit of the number of bundles per component event is set to three (3) by default. If more than three events occur for a component, then the events are dropped with the status message **EVENTLOGLIMITREACHED**. The auto-collection of the component event restarts when the event log has rolled over.

Example:

```
switch# show system internal event-logs auto-collect history
DateTime          Snapshot ID  Syslog                               Status/Secs/Logsize (Bytes)
2020-Jun-27 07:20:03 1140276903 ACLMGR-0-TEST_SYSLOG                EVENTLOGLIMITREACHED
2020-Jun-27 07:15:14 1026359228 ACLMGR-0-TEST_SYSLOG                RATELIMITED
2020-Jun-27 07:15:09 384952880  ACLMGR-0-TEST_SYSLOG                RATELIMITED
2020-Jun-27 07:13:55 1679333688 ACLMGR-0-TEST_SYSLOG                PROCESSED:2:9332278
2020-Jun-27 07:13:52 1679333688 ACLMGR-0-TEST_SYSLOG                PROCESSING
2020-Jun-27 07:12:55 502545693  ACLMGR-0-TEST_SYSLOG                RATELIMITED
2020-Jun-27 07:12:25 1718497217 ACLMGR-0-TEST_SYSLOG                RATELIMITED
2020-Jun-27 07:08:25 1432687513 ACLMGR-0-TEST_SYSLOG                PROCESSED:2:10453823
2020-Jun-27 07:08:22 1432687513 ACLMGR-0-TEST_SYSLOG                PROCESSING
2020-Jun-27 07:06:16 90042807   ACLMGR-0-TEST_SYSLOG                RATELIMITED
2020-Jun-27 07:03:26 1737578642 ACLMGR-0-TEST_SYSLOG                RATELIMITED
2020-Jun-27 07:02:56 40101277  ACLMGR-0-TEST_SYSLOG                PROCESSED:3:10542045
2020-Jun-27 07:02:52 40101277  ACLMGR-0-TEST_SYSLOG                PROCESSING
```

Auto-Collection Log Files

About Auto-Collection Log Files

The configuration in a YAML file determines the contents of an auto-collected log file. You can't configure the amount of memory used for collected log files. You can configure the frequency of when the stored files get purged.

Autocollected log files get saved in the following directory:

```
switch# dir bootflash:eem_snapshots
 44205843 Sep 25 11:08:04 2019
1480625546_SECURITYD_2_FEATURE_ENABLE_DISABLE_eem_snapshot.tar.gz
  Usage for bootflash://sup-local
 6940545024 bytes used
44829761536 bytes free
51770306560 bytes total
```

Accessing the Log Files

Locate the logs by using the command keyword "debug":

```
switch# dir debug:///
...
 26 Oct 22 10:46:31 2019 log-dump
 24 Oct 22 10:46:31 2019 log-snapshot-auto
 26 Oct 22 10:46:31 2019 log-snapshot-user
```

The following table describes the log locations and the log types stored.

Location	Description
log-dump	This folder stores Event logs on log rollover.
log-snapshot-auto	This folder contains the auto-collected logs for syslog events 0, 1, 2.
log-snapshot-user	This folder stores the collected logs when you run the <code>bloggerd log-snapshot <></code> command.

Use the following example to view the log files generated on log rollover:

```
switch# dir debug:log-dump/
debug:log-dump/20191022104656_evtlog_archive.tar
debug:log-dump/20191022111241_evtlog_archive.tar
debug:log-dump/20191022111841_evtlog_archive.tar
debug:log-dump/20191022112431_evtlog_archive.tar
debug:log-dump/20191022113042_evtlog_archive.tar
debug:log-dump/20191022113603_evtlog_archive.tar
```

Parsing the Log tar Files

Use the following example to parse the logs in the tar files:

```
switch# show system internal event-logs parse debug:log-dump/20191022104656_evtlog_archive.tar
-----LOGS:/tmp/BLOGGERD0.991453012199/tmp/1-191022104658-191022110741-device_test-M27-V1-11:0-P884.gz-----
2019 Oct 22 11:07:41.597864 E_DEBUG Oct 22 11:07:41 2019(diag_test_start):Data Space
Limits(bytes): Soft: -1 Ha rd: -1
2019 Oct 22 11:07:41.597857 E_DEBUG Oct 22 11:07:41 2019(diag_test_start):Stack Space
Limits(bytes): Soft: 500000 Hard: 500000
2019 Oct 22 11:07:41.597850 E_DEBUG Oct 22 11:07:41 2019(diag_test_start):AS: 1005952076
-1
2019 Oct 22 11:07:41.597406 E_DEBUG Oct 22 11:07:41 2019(device_test_process_events):Sdwrap
msg unknown
2019 Oct 22 11:07:41.597398 E_DEBUG Oct 22 11:07:41 2019(diag_test_start):Going back to
select
2019 Oct 22 11:07:41.597395 E_DEBUG Oct 22 11:07:41 2019(nvram_test):TestNvram examine 27
blocks
2019 Oct 22 11:07:41.597371 E_DEBUG Oct 22 11:07:41 2019(diag_test_start):Parent: Thread
created test index:4 thread_id:-707265728
2019 Oct 22 11:07:41.597333 E_DEBUG Oct 22 11:07:41 2019(diag_test_start):Node inserted
2019 Oct 22 11:07:41.597328 E_DEBUG Oct 22 11:07:41 2019(diag_test_start):The test index
in diag is 4
2019 Oct 22 11:07:41.597322 E_DEBUG Oct 22 11:07:41 2019(diag_test_start):result severity
level
2019 Oct 22 11:07:41.597316 E_DEBUG Oct 22 11:07:41 2019(diag_test_start):callhome alert
level
```

The following table describes the additional keywords available for parsing the specific tar file:

Keyword	Description
component	Decode logs belonging to the component identified by process name.
from-datetime	Decode logs from a specific date and time in <code>yy[mm[dd[HH[MM[SS]]]]]</code> format.
instance	List of SDWRAP buffer instances to be decoded (comma separated).
module	Decode logs from modules such as SUP and LC (using module IDs).
to-datetime	Decode logs up to a specific date and time in <code>yy[mm[dd[HH[MM[SS]]]]]</code> format.

Copying Logs to a Different Location

Use the following example to copy logs to a different location such as a remote server:

```
switch# copy debug:log-dump/20191022104656_evtlog_archive.tar
scp://<ip-address>/nobackup/<user> vrf management use-kstack
Enter username: user@<ip-address>'s password:
20191022104656_evtlog_archive.tar                               100% 130KB
130.0KB/s   00:00
Copy complete, now saving to disk (please wait)...
Copy complete.
```

Purging Auto-Collection Log Files

There are two types of generated trigger-based auto-collection logs: EventHistory and EventBundle.

Purge Logic for EventHistory Logs

For event history, purging occurs in the /var/sysmgr/srv_logs/xport folder. 250MB of partitioned RAM is mounted at /var/sysmgr/srv_logs directory.

If the /var/sysmgr/srv_logs memory usage is under 65% of the 250MB allocated, no files get purged. When the memory utilization reaches the 65% limit level, the oldest files get purged until there's enough memory available to continue saving new logs.

Purge Logic for EventBundle Logs

For event bundles, the purge logic occurs in the /bootflash/eem_snapshots folder. For storing the auto-collected snapshots, the EEM auto-collect script allocates 5% of the bootflash storage. The logs get purged once the 5% bootflash capacity is used.

When a new auto-collected log is available but there's no space to save it in bootflash (already at 5% capacity), the system checks the following:

1. If there are existing auto-collected files that are more than 12 hours old, the system deletes the files and the new logs get copied.
2. If the existing auto collected files are less than 12 hours old, the system discards the newly collected logs without saving them.

You can modify the 12-hour default purge time by using the following commands. The time specified in the command is in minutes.

```
switch(config)# event manager applet test override __syslog_trigger_default
switch(config-applet)# action 1.0 collect test.yaml purge-time 300 $_syslog_msg
```

event manager command: *test* is an example name for the policy. **__syslog_trigger_default** is the name of the system policy that you want to override. This name must begin with a double underscore (__).

action command: **1.0** is an example number for the order in which the action is executed. **collect** indicates that data is collected using the YAML file. *test.yaml* is an example name of the YAML file. **\$_syslog_msg** is the name of the component.



Note At any given time, there can be only one trigger-based auto-collection event in progress. If another new log event is attempting to be stored when auto-collection is already occurring, the new log event is discarded.

By default, there's only one trigger-based bundle collected every five minutes (300 sec). This rate limiting is also configurable by the following commands. The time specified in the command is in seconds.

```
switch(config)# event manager applet test override __syslog_trigger_default
switch(config-applet)# action 1.0 collect test.yaml rate-limit 600 $_syslog_msg
```

event manager command: *test* is an example name for the policy. **__syslog_trigger_default** is an example name of the system policy to override. This name must begin with a double underscore (__).

action command: **1.0** is an example number for the order in which the action is executed. **collect** indicates that data is collected using the YAML file. *test.yaml* is an example name of the YAML file. **\$_syslog_msg** is the name of the component.

Auto-Collection Statistics and History

The following example shows trigger-based collection statistics:

```
switch# show system internal event-logs auto-collect statistics
-----EEM Auto Collection Statistics-----
Syslog Parse Successful :88 Syslog Parse Failure :0
Syslog Ratelimited :0 Rate Limit Check Failed :0
Syslog Dropped(Last Action In Prog) :53 Storage Limit Reached :0
User Yaml Action File Unavailable :0 User Yaml Parse Successful :35
User Yaml Parse Error :0 Sys Yaml Action File Unavailable :11
Sys Yaml Parse Successful :3 Sys Yaml Parse Error :0
Yaml Action Not Defined :0 Syslog Processing Initiated :24
Log Collection Failed :0 Tar Creation Error :0
Signal Interrupt :0 Script Exception :0
Syslog Processed Successfully :24 Logfiles Purged :0
```

The following example shows trigger-based collection history (the processed syslogs, process time, size of the data collected) obtained using a CLI command:

```
switch# show system internal event-logs auto-collect history
DateTime Snapshot ID Syslog Status/Secs/Logsize(Bytes)
2019-Dec-04 05:30:32 1310232084 VPC-0-TEST_SYSLOG PROCESSED:9:22312929
2019-Dec-04 05:30:22 1310232084 VPC-0-TEST_SYSLOG PROCESSING
2019-Dec-04 04:30:13 1618762270 ACLMGR-0-TEST_SYSLOG PROCESSED:173:33194665
2019-Dec-04 04:28:47 897805674 SYSLOG-1-SYSTEM_MSG DROPPED-LASTACTIONINPROG
2019-Dec-04 04:28:47 947981421 SYSLOG-1-SYSTEM_MSG DROPPED-LASTACTIONINPROG
2019-Dec-04 04:27:19 1618762270 ACLMGR-0-TEST_SYSLOG PROCESSING
2019-Dec-04 02:17:16 1957148102 CARDCLIENT-2-FPGA_BOOT_GOLDEN NOYAMLFILEFOUND
```

Verifying Trigger-Based Log Collection

Verify that the trigger-based log collection feature is enabled by entering the **show event manager system-policy | i trigger** command as in this example:

```
switch# show event manager system-policy | i trigger n 2
      Name : __syslog_trigger_default
      Description : Default policy for trigger based logging
      Overridable : Yes
      Event type : 0x2101
```

Checking Trigger-Based Log File Generation

You can check to see if the trigger-based auto-collection feature has generated any event log files. Enter one of the commands in the following examples:

```
switch# dir bootflash:eem_snapshots
9162547 Nov 12 22:33:15 2019 1006309316_SECURITYD_2_FEATURE_ENABLE_DISABLE_eem_snapshot.tar.gz

Usage for bootflash://sup-local
8911929344 bytes used
```

```

3555950592 bytes free
12467879936 bytes total

switch# dir debug:log-snapshot-auto/
63435992 Dec 03 06:28:52 2019
20191203062841_1394408030_PLATFORM_2_MOD_PWRDN_eem_snapshot.tar.gz

Usage for debug://sup-local
544768 bytes used
4698112 bytes free
5242880 bytes total

```

Local Log File Storage

Local log file storage capabilities:

- Amount of local data storage time depends on the scale, and type, of deployment. For both modular and nonmodular switches, the storage time is from 15 minutes to several hours of data. To be able to collect relevant logs that span a longer period:
 - Only enable event log retention for the specific services/features you need. See [Enabling Extended Log File Retention For a Single Service](#) , on page 144.
 - Export the internal event logs off the switch. See [External Log File Storage](#), on page 156.
- Compressed logs are stored in RAM.
- 250MB memory is reserved for log file storage.
- Log files are optimized in tar format (one file for every five minutes or 10MB, whichever occurs first).
- Allow snap-shot collection.

Generating a Local Copy of Recent Log Files

Extended Log File Retention is enabled by default for all services running on a switch. For local storage, the log files are stored on flash memory. Use the following procedure to generate a copy of up to ten of the most recent event log files.

SUMMARY STEPS

1. **bloggerd log-snapshot** [*file-name*] [**bootflash:** *file-path* | **logflash:** *file-path* | **usb1:**] [**size** *file-size*] [**time** *minutes*]

DETAILED STEPS

	Command or Action	Purpose
Step 1	bloggerd log-snapshot [<i>file-name</i>] [bootflash: <i>file-path</i> logflash: <i>file-path</i> usb1:] [size <i>file-size</i>] [time <i>minutes</i>] Example: switch# bloggerd log-snapshot snapshot1	Creates a snapshot bundle file of the last ten event logs stored on the switch. Default storage for this operation is logflash . <i>file-name</i> : The filename of the generated snapshot log file bundle. Use a maximum of 64 characters for <i>file-name</i> .

	Command or Action	Purpose
		<p>Note This variable is optional. If it is not configured, the system applies a timestamp and "_snapshot_bundle.tar" as the filename. Example:</p> <pre>20200605161704_snapshot_bundle.tar</pre> <p>bootflash: <i>file-path</i>: The file path where the snapshot log file bundle is being stored on the bootflash. Choose one of the following initial paths:</p> <ul style="list-style-type: none"> • bootflash:/// • bootflash://module-1/ • bootflash://sup-1/ • bootflash://sup-active/ • bootflash://sup-local/ <p>logflash: <i>file-path</i>: The file path where the snapshot log file bundle is being stored on the logflash. Choose one of the following initial paths:</p> <ul style="list-style-type: none"> • logflash:/// • logflash://module-1/ • logflash://sup-1/ • logflash://sup-active/ • logflash://sup-local/ <p>usb1: The file path where the snapshot log file bundle is being stored on the USB device.</p> <p>size <i>file-size</i>: The snapshot log file bundle based on size in megabytes (MB). Range is from 5MB through 250MB.</p> <p>time <i>minutes</i>: The snapshot log file bundle based on the last x amount of time (minutes). Range is from 1 minute through 30 minutes.</p>

Example

```
switch# bloggerd log-snapshot snapshot1
Snapshot generated at logflash:evt_log_snapshot/snapshot1_snapshot_bundle.tar Please cleanup
once done.
switch#
switch# dir logflash:evt_log_snapshot
159098880 Dec 05 06:40:24 2019 snapshot1_snapshot_bundle.tar
159354880 Dec 05 06:40:40 2019 snapshot2_snapshot_bundle.tar

Usage for logflash://sup-local
759865344 bytes used
```

```
5697142784 bytes free
6457008128 bytes total
```

Display the same files using the command in this example:

```
switch# dir debug:log-snapshot-user/
159098880 Dec 05 06:40:24 2019 snapshot1_snapshot_bundle.tar
159354880 Dec 05 06:40:40 2019 snapshot2_snapshot_bundle.tar
```

```
Usage for debug://sup-local
929792 bytes used
4313088 bytes free
5242880 bytes total
```



Note The file name is identified at the end of the example. Each individual log file is also identified by the date and time it was generated.

External Log File Storage

An external server solution provides the capability to store logs off-switch in a secure manner.



Note To create the external storage capability, contact Cisco Technical Assistance Center(TAC) to help deploy the external server solution.

The following are external log file storage capabilities:

- Enabled on-demand
- HTTPS-based transport
- Storage requirements:
 - Nonmodular switches: 300MB
 - Modular switches: 12GB (per day, per switch)
- An external server generally stores logs for 10 switches. However, there's no firm limit to the number of switches supported by an external server.

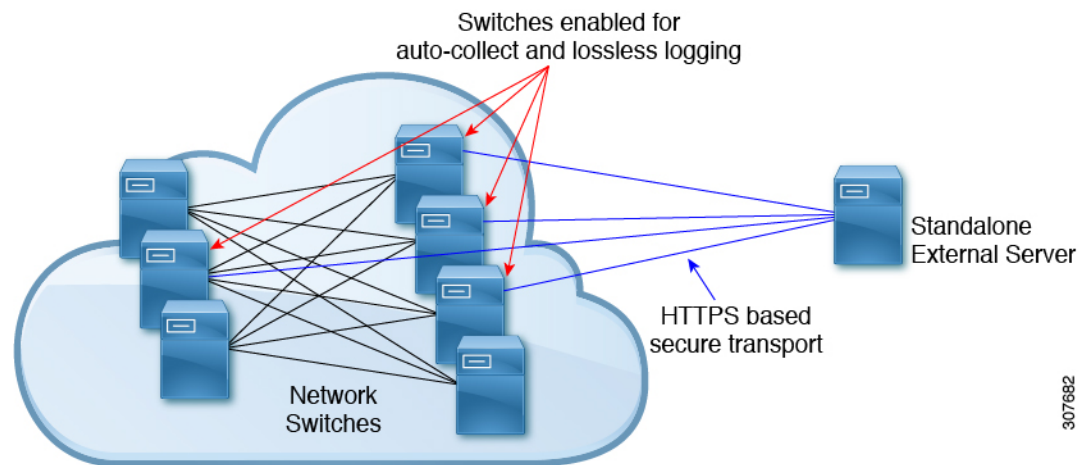

307682

The external server solution has the following characteristics:

- Controller-less environment
- Manual management of security certificates
- Three supported use-cases:
 - Continuous collection of logs from selected switches
 - TAC-assisted effort to deploy and upload logs to Cisco servers.
 - Limited on-premise processing



Note Contact Cisco TAC for information regarding the setup and collection of log files in an external server.



CHAPTER 13

Configuring SPAN

This chapter contains the following sections:

- [Information About SPAN](#), on page 159
- [Guidelines and Limitations for SPAN](#), on page 159
- [SPAN Sources](#), on page 160
- [Characteristics of Source Ports](#), on page 160
- [SPAN Destinations](#), on page 160
- [Characteristics of Destination Ports](#), on page 161
- [SPAN and ERSPAN Filtering](#), on page 161
- [SPAN and ERSPAN Sampling](#), on page 163
- [SPAN and ERSPAN Truncation](#), on page 163
- [Creating or Deleting a SPAN Session](#), on page 164
- [Configuring an Ethernet Destination Port](#), on page 164
- [Configuring Source Ports](#), on page 165
- [Configuring Source Port Channels or VLANs](#), on page 166
- [Configuring the Description of a SPAN Session](#), on page 167
- [Activating a SPAN Session](#), on page 168
- [Suspending a SPAN Session](#), on page 168
- [Configuring a SPAN Filter](#), on page 169
- [Configuring SPAN Sampling](#), on page 170
- [Configuring SPAN Truncation](#), on page 171
- [Displaying SPAN Information](#), on page 172

Information About SPAN

The Switched Port Analyzer (SPAN) feature (sometimes called port mirroring or port monitoring) selects network traffic for analysis by a network analyzer. The network analyzer can be a Cisco SwitchProbe or other Remote Monitoring (RMON) probes.

Guidelines and Limitations for SPAN

SPAN have the following guideline and limitation:

- You can monitor the same source interfaces (physical port or port-channel) in multiple local SPAN sessions.
- The Cisco Nexus 3500 Series switches do not support access-group command for SPAN sessions.

SPAN Sources

SPAN sources refer to the interfaces from which traffic can be monitored. The Cisco Nexus device supports Ethernet, port channels, and VLANs as SPAN sources. With VLANs, all supported interfaces in the specified VLAN are included as SPAN sources. You can choose the SPAN traffic in the ingress direction, the egress direction, or both directions for Ethernet source interfaces:

- Ingress source (Rx)—Traffic entering the device through this source port is copied to the SPAN destination port.
- Egress source (Tx)—Traffic exiting the device through this source port is copied to the SPAN destination port.

Characteristics of Source Ports

A source port, also called a monitored port, is a switched interface that you monitor for network traffic analysis. The switch supports any number of ingress source ports (up to the maximum number of available ports on the switch) and any number of source VLANs.

A source port has these characteristics:

- Can be of Ethernet, port channel, or VLAN port type.
- Cannot be a destination port.
- Can be configured with a direction (ingress, egress, or both) to monitor. For VLAN sources, the monitored direction can only be ingress and applies to all physical ports in the group. The RX/TX option is not available for VLAN SPAN sessions.
- Can be in the same or different VLANs.



Note

- The maximum number of source ports per SPAN session is 128 ports.
-

SPAN Destinations

SPAN destinations refer to the interfaces that monitors source ports. The Cisco Nexus Series device supports Ethernet interfaces as SPAN destinations.

Characteristics of Destination Ports

Each local SPAN session must have a destination port (also called a monitoring port) that receives a copy of traffic from the source ports or VLANs. A destination port has these characteristics:

- Can be any physical port. Source Ethernet and FCoE ports cannot be destination ports.
- Cannot be a source port.
- Cannot be a port channel.
- Does not participate in spanning tree while the SPAN session is active.
- Is excluded from the source list and is not monitored if it belongs to a source VLAN of any SPAN session.
- Receives copies of sent and received traffic for all monitored source ports.
- The same destination interface cannot be used for multiple SPAN sessions. However, an interface can act as a destination for a SPAN and an ERSPAN session.

SPAN and ERSPAN Filtering

A SPAN or ERSPAN session can be used to monitor all the traffic on all the source interfaces. This volume of traffic can cause packet drops if there are congestions or if the destination bandwidth is not enough to monitor all the traffic.

Cisco NX-OS Release 6.0(2)A4(1) provides the ability to filter out specific SPAN or ERSPAN traffic flows that must be monitored. Filtering is achieved by creating a filter and attaching it to a SPAN or ERSPAN session. Only the packets that match the filter are mirrored.

Filtering can be of the following types:

- MAC-based
- IP-based
- VLAN-based

Guidelines and Limitations for SPAN and ERSPAN Filtering

SPAN and ERSPAN filtering have the following guidelines and limitations:

- Cisco Nexus 3500 Series switches drop the SPAN copies while spanning an interface in the rx direction and another interface in the tx direction when the traffic starts. It happens due to the default SPAN threshold limit being low and it cannot handle the burst traffic for SPAN. Use the CLI command **hardware profile buffer span-threshold <xx>** to increase the SPAN threshold.



Note Increasing the SPAN threshold affects the shared buffer allocation. It allocates the SPAN buffers from the shared buffer pool.

- The span-threshold least value has been updated from 0 to 2. When you set the span-threshold to a lowest value of 2, the SPAN buffer occupied is 528. When you use the negate command **no hardware profile buffer span-threshold 2**, the span-threshold value is 208. The default value is lesser than the least value of span-threshold.
- When a source interface in a SPAN session is operationally down, then that SPAN session will not go operationally down. This behavior does not impact any functionality
- Configuring two SPAN or ERSPAN sessions on the same source interface with only one filter is not supported. If the same source is used in multiple SPAN or ERSPAN sessions, either all the sessions must have different filters or no sessions should have filters.
- SPAN filtering supports only 16 filters. These filters can be a combination of VLAN-based, IP-based, and MAC-based filters.
- When a SPAN session is configured with a multicast router port being the source port, the destination port sees all the multicast traffic even when there is no traffic that is actually being forwarded to the source port. This is due to a current limitation of the multicast/SPAN implementation.
- SPAN filtering is applicable for all the traffic of the switch except the SPAN source interface traffic.
- You can configure only one IP-based, one MAC-based and one VLAN-based filter per SPAN session.
- The number of filters is further restricted by the number of SPAN sessions and the type of source as follows:
 - A maximum of 8 MAC-based, 8 IP-based or 8 VLAN-based filters can be configured.
 - A maximum of 4 IP-based, 4 MAC-based or 4 VLAN-based filters can be attached to all interface-based SPAN sessions.
 - A maximum of 8 IP-based, 8 MAC-based or 8 VLAN-based filters can be attached to all VLAN-based SPAN sessions.
- Filters can be used only in the ingress direction. This is not configurable.
- A SPAN session must be up to for filters to work.
- You cannot configure filters on ERSPAN-dst sessions.
- You cannot configure filters on Warp SPAN sessions.
- The control-packet filter is always applied in the egress direction.
- The control-packet filter is recommended when both, the source and the destination interfaces of the ERSPAN session are PTP enabled.

SPAN and ERSPAN Control-packet Filtering

Cisco NX-OS Release 6.0(2)A8(9) provides the ability to filter out CPU generated packets going out of the SPAN source interface. Control-packet filter is applied in the egress direction, and is therefore effective on source interfaces enabled for Tx mirroring.

SPAN and ERSPAN Sampling

Cisco NX-OS Release 6.0(2)A4(1) supports sampling of source packets for each SPAN or ERSPAN session. Monitoring only a sample number of source packets helps reduce SPAN or ERSPAN bandwidth. This sample is defined by a range that you can configure. For example, if you configure the range as 2, 1 out of every 2 source packets will be spanned. Similarly, if you configure the range as 1023, 1 out of every 1023 packets will be spanned. This method provides an accurate count of SPAN or ERSPAN source packets, but it does not include any time-related information about the spanned packets.

By default, SPAN and ERSPAN sampling are disabled. To use sampling, you must enable it for each SPAN or ERSPAN session.

Guidelines and Limitations for SPAN and ERSPAN Sampling

SPAN and ERSPAN sampling have the following guidelines and limitations:

- Sampling is only supported for local and ERSPAN-src sessions.
- Sampling is not supported for ERSPAN-dst sessions.
- Sampling is not supported for Warp SPAN sessions.
- The supported sampling range is from 2 to 1023.

SPAN and ERSPAN Truncation

Cisco NX-OS Release 6.0(2)A4(1) introduces truncation of source packets for each SPAN or ERSPAN session based on the size of their MTU. Truncation helps reduce SPAN or ERSPAN bandwidth by reducing the size of packets monitored. MTU truncation can be set from 64 bytes to 1518 bytes. Any SPAN or ERSPAN packet that is larger than the configured MTU size is truncated to the given size with a 4-byte offset. For example, if you configure the MTU as 300 bytes, the maximum size of the replicated packet is 304 bytes.

By default, SPAN and ERSPAN truncation are disabled. To use truncation, you must enable it for each SPAN or ERSPAN session.

Guidelines and Limitations for SPAN and ERSPAN Truncation

SPAN and ERSPAN truncation have the following guidelines and limitations:

- Truncation is only supported for local and ERSPAN-src sessions.
- Truncation is not supported for ERSPAN-dst sessions.
- Truncation is not supported for Warp SPAN sessions.
- The supported MTU range is from 64 bytes to 1518 bytes.

Creating or Deleting a SPAN Session

You create a SPAN session by assigning a session number using the **monitor session** command. If the session already exists, any additional configuration information is added to the existing session.

SUMMARY STEPS

1. switch# **configure terminal**
2. switch(config)# **monitor session** *session-number*

DETAILED STEPS

	Command or Action	Purpose
Step 1	switch# configure terminal	Enters global configuration mode.
Step 2	switch(config)# monitor session <i>session-number</i>	Enters the monitor configuration mode. New session configuration is added to the existing session configuration.

Example

The following example shows how to configure a SPAN monitor session:

```
switch# configure terminal
switch(config) # monitor session 2
switch(config) #
```

Configuring an Ethernet Destination Port

You can configure an Ethernet interface as a SPAN destination port.



Note The SPAN destination port can only be a physical port on the switch.

SUMMARY STEPS

1. switch# **configure terminal**
2. switch(config)# **interface ethernet** *slot/port*
3. switch(config-if)# **switchport monitor**
4. switch(config-if)# **exit**
5. switch(config)# **monitor session** *session-number*
6. switch(config-monitor)# **destination interface ethernet** *slot/port*

DETAILED STEPS

	Command or Action	Purpose
Step 1	switch# configure terminal	Enters global configuration mode.
Step 2	switch(config)# interface ethernet <i>slot/port</i>	Enters interface configuration mode for the Ethernet interface with the specified slot and port. Note To enable the switchport monitor command on virtual ethernet ports, you can use the interface vethernet <i>slot/port</i> command.
Step 3	switch(config-if)# switchport monitor	Enters monitor mode for the specified Ethernet interface. Priority flow control is disabled when the port is configured as a SPAN destination.
Step 4	switch(config-if)# exit	Reverts to global configuration mode.
Step 5	switch(config)# monitor session <i>session-number</i>	Enters monitor configuration mode for the specified SPAN session.
Step 6	switch(config-monitor)# destination interface ethernet <i>slot/port</i>	Configures the Ethernet SPAN destination port. Note To enable the virtual ethernet port as destination interface in the monitor configuration, you can use the destination interface vethernet <i>slot/port</i> command.

Example

The following example shows how to configure an Ethernet SPAN destination port (HIF):

```
switch# configure terminal
switch(config)# interface ethernet100/1/24
switch(config-if)# switchport monitor
switch(config-if)# exit
switch(config)# monitor session 1
switch(config-monitor)# destination interface ethernet100/1/24
switch(config-monitor)#
```

The following example shows how to configure a virtual ethernet (VETH) SPAN destination port:

```
switch# configure terminal
switch(config)# interface vethernet10
switch(config-if)# switchport monitor
switch(config-if)# exit
switch(config)# monitor session 2
switch(config-monitor)# destination interface vethernet10
switch(config-monitor)#
```

Configuring Source Ports

Source ports can only be Ethernet ports.

SUMMARY STEPS

1. switch# **configure terminal**
2. switch(config) # **monitor session** *session-number*
3. switch(config-monitor) # **source interface** *type slot/port* [**rx** | **tx** | **both**]

DETAILED STEPS

	Command or Action	Purpose
Step 1	switch# configure terminal	Enters global configuration mode.
Step 2	switch(config) # monitor session <i>session-number</i>	Enters monitor configuration mode for the specified monitoring session.
Step 3	switch(config-monitor) # source interface <i>type slot/port</i> [rx tx both]	Adds an Ethernet SPAN source port and specifies the traffic direction in which to duplicate packets. You can enter a range of Ethernet, Fibre Channel, or virtual Fibre Channel ports. You can specify the traffic direction to duplicate as ingress (Rx), egress (Tx), or both. By default, the direction is both.

Example

```
switch# configure terminal
switch(config)# monitor session 2
switch(config-monitor)# source interface ethernet 1/16
switch(config-monitor)#
```

Configuring Source Port Channels or VLANs

You can configure the source channels for a SPAN session. These ports can be port channels and VLANs. The monitored direction can be ingress, egress, or both and applies to all physical ports in the group.

SUMMARY STEPS

1. switch# **configure terminal**
2. switch(config) # **monitor session** *session-number*
3. switch(config-monitor) # **source** {**interface** {**port-channel** | **san-port-channel**} *channel-number* [**rx** | **tx** | **both**] | **vlan** *vlan-range* | **vsan** *vsan-range* }

DETAILED STEPS

	Command or Action	Purpose
Step 1	switch# configure terminal	Enters global configuration mode.
Step 2	switch(config) # monitor session <i>session-number</i>	Enters monitor configuration mode for the specified SPAN session.

	Command or Action	Purpose
Step 3	switch(config-monitor) # source { interface { port-channel san-port-channel } <i>channel-number</i> [rx tx both] vlan <i>vlan-range</i> vsan <i>vsan-range</i> }	Configures port channel, SAN port channel, VLAN, or VSAN sources. For VLAN or VSAN sources, the monitored direction is implicit.

Example

The following example shows how to configure a port channel SPAN source:

```
switch# configure terminal
switch(config)# monitor session 2
switch(config-monitor)# source interface port-channel 1 rx
switch(config-monitor)# source interface port-channel 3 tx
switch(config-monitor)# source interface port-channel 5 both
switch(config-monitor)#
```

The following example shows how to configure a VLAN SPAN source:

```
switch# configure terminal
switch(config)# monitor session 2
switch(config-monitor)# source vlan 1
switch(config-monitor)#
```

Configuring the Description of a SPAN Session

For ease of reference, you can provide a descriptive name for a SPAN session.

SUMMARY STEPS

1. switch# **configure terminal**
2. switch(config) # **monitor session** *session-number*
3. switch(config-monitor) # **description** *description*

DETAILED STEPS

	Command or Action	Purpose
Step 1	switch# configure terminal	Enters global configuration mode.
Step 2	switch(config) # monitor session <i>session-number</i>	Enters monitor configuration mode for the specified SPAN session.
Step 3	switch(config-monitor) # description <i>description</i>	Creates a descriptive name for the SPAN session.

Example

The following example shows how to configure a SPAN session description:

```
switch# configure terminal
switch(config) # monitor session 2
```

```
switch(config-monitor) # description monitoring ports eth2/2-eth2/4
switch(config-monitor) #
```

Activating a SPAN Session

The default is to keep the session state shut. You can open a session that duplicates packets from sources to destinations.

SUMMARY STEPS

1. switch# **configure terminal**
2. switch(config) # **no monitor session {all | session-number} shut**

DETAILED STEPS

	Command or Action	Purpose
Step 1	switch# configure terminal	Enters global configuration mode.
Step 2	switch(config) # no monitor session {all session-number} shut	Opens the specified SPAN session or all sessions.

Example

The following example shows how to activate a SPAN session:

```
switch# configure terminal
switch(config) # no monitor session 3 shut
```

Suspending a SPAN Session

By default, the session state is **shut**.

SUMMARY STEPS

1. switch# **configure terminal**
2. switch(config) # **monitor session {all | session-number} shut**

DETAILED STEPS

	Command or Action	Purpose
Step 1	switch# configure terminal	Enters global configuration mode.
Step 2	switch(config) # monitor session {all session-number} shut	Suspends the specified SPAN session or all sessions.

Example

The following example shows how to suspend a SPAN session:

```
switch# configure terminal
switch(config) # monitor session 3 shut
switch(config) #
```

Configuring a SPAN Filter

You can configure SPAN filters for local and ERSPAN-source sessions only.

SUMMARY STEPS

1. switch# **configure terminal**
2. switch(config)# **monitor session** *session-number*
3. switch(config-monitor)# **source** {**interface** {**port-channel**} *channel-number* [**rx** | **tx** | **both**] | **vlan** *vlan-range*}
4. switch(config-monitor)# **filter** {**ip** *source-ip-address source-ip-mask destination-ip-address destination-ip-mask*}
5. switch(config-monitor)# **destination interface ethernet** *slot/port*

DETAILED STEPS

	Command or Action	Purpose
Step 1	switch# configure terminal	Enters global configuration mode.
Step 2	switch(config)# monitor session <i>session-number</i>	Enters monitor configuration mode for the specified SPAN session.
Step 3	switch(config-monitor)# source { interface { port-channel } <i>channel-number</i> [rx tx both] vlan <i>vlan-range</i> }	Configures port channel or VLAN sources. For VLAN sources, the monitored direction is implicit.
Step 4	switch(config-monitor)# filter { ip <i>source-ip-address source-ip-mask destination-ip-address destination-ip-mask</i> }	Creates a SPAN filter.
Step 5	switch(config-monitor)# destination interface ethernet <i>slot/port</i>	Configures the Ethernet SPAN destination port.

Example

The following example shows how to configure an IP-based SPAN filter for a local session:

```
switch# configure terminal
Enter configuration commands, one per line. End with CNTL/Z.
switch(config) # monitor session 1
switch(config-monitor) # source interface Ethernet 1/7 rx
switch(config-monitor) # filter ip 10.1.1.1 255.255.255.255 20.1.1.1 255.255.255.255
switch(config-monitor) # destination interface Ethernet 1/48
switch(config-monitor) # no shut
```

```
switch(config-monitor)#
```

The following example shows how to configure a VLAN-based SPAN filter for a local session:

```
switch# configure terminal
Enter configuration commands, one per line. End with CNTL/Z.
switch(config)# monitor session 3
switch(config-monitor)# source vlan 200
switch(config-monitor)# destination interface Ethernet 1/4
switch(config-monitor)# no shut
switch(config-monitor)#
```

Configuring SPAN Sampling

You can configure sampling for local and ERSPAN-source sessions only.

SUMMARY STEPS

1. switch# **configure terminal**
2. switch(config)# **monitor session** *session-number*
3. switch(config-monitor)# **source** {**interface** {**port-channel**} *channel-number* [**rx** | **tx** | **both**] | **vlan** *vlan-range*}
4. switch(config-monitor)# **sampling** *sampling-range*
5. switch(config-monitor)# **destination interface ethernet** *slot/port*

DETAILED STEPS

	Command or Action	Purpose
Step 1	switch# configure terminal	Enters global configuration mode.
Step 2	switch(config)# monitor session <i>session-number</i>	Enters monitor configuration mode for the specified SPAN session.
Step 3	switch(config-monitor)# source { interface { port-channel } <i>channel-number</i> [rx tx both] vlan <i>vlan-range</i> }	Configures port channel or VLAN sources. For VLAN sources, the monitored direction is implicit.
Step 4	switch(config-monitor)# sampling <i>sampling-range</i>	Configures a range for spanning packets. If the range is defined as <i>n</i> , every <i>n</i> th packet will be spanned. The sampling range is between 2 and 1023.
Step 5	switch(config-monitor)# destination interface ethernet <i>slot/port</i>	Configures the Ethernet SPAN destination port.

Example

The following example shows how to configure sampling on a VLAN for a local session:

```
switch# configure terminal
Enter configuration commands, one per line. End with CNTL/Z.
switch(config)# monitor session 1
```

```

switch(config-monitor)# source vlan 100
switch(config-monitor)# sampling 10
switch(config-monitor)# destination interface ethernet 1/48
switch(config-monitor)# no shut
switch(config-monitor)# show monitor session 1
    session 1
    -----
type           : local
state          : up
sampling       : 10
source intf    :
    rx         : Eth1/3      Eth1/7
    tx         :
    both       :
source VLANs   :
    rx         : 100
destination ports : Eth1/48

```

Legend: f = forwarding enabled, l = learning enabled

The following example shows how to configure sampling on an Ethernet interface for a local session:

```

switch# configure terminal
Enter configuration commands, one per line. End with CNTL/Z.
switch(config)# monitor session 3
switch(config-monitor)# source interface ethernet 1/8
switch(config-monitor)# sampling 20
switch(config-monitor)# destination interface ethernet 1/4
switch(config-monitor)# show monitor session 3
    session 3
    -----
type           : local
state          : down (No operational src/dst)
sampling       : 20
source intf    :
    rx         : Eth1/8
    tx         : Eth1/8
    both       : Eth1/8
source VLANs   :
    rx         : 200
destination ports : Eth1/4

```

Legend: f = forwarding enabled, l = learning enabled

Configuring SPAN Truncation

You can configure truncation for local and ERSPAN-source sessions only.

SUMMARY STEPS

1. switch# **configure terminal**
2. switch(config)# **monitor session** *session-number*
3. switch(config-monitor) # **source** {**interface** {**port-channel**} *channel-number* [**rx** | **tx** | **both**] | **vlan** *vlan-range*}
4. switch(config-monitor) # **mtu** *size*
5. switch(config-monitor)# **destination interface ethernet** *slot/port*

DETAILED STEPS

	Command or Action	Purpose
Step 1	switch# configure terminal	Enters global configuration mode.
Step 2	switch(config)# monitor session <i>session-number</i>	Enters monitor configuration mode for the specified SPAN session.
Step 3	switch(config-monitor)# source { interface { port-channel } <i>channel-number</i> [rx tx both] vlan <i>vlan-range</i> }	Configures port channel or VLAN sources. For VLAN sources, the monitored direction is implicit.
Step 4	switch(config-monitor)# mtu <i>size</i>	Configures the MTU size for truncation. Any SPAN packet that is larger than the configured MTU size is truncated to the configured size with a 4-byte offset. The MTU truncation size is between 64 bytes and 1518 bytes.
Step 5	switch(config-monitor)# destination interface ethernet <i>slot/port</i>	Configures the Ethernet SPAN destination port.

Example

The following example shows how to configure MTU truncation for a local session:

```
switch# configure terminal
switch(config)# monitor session 5
switch(config-monitor)# source interface ethernet 1/5 both
switch(config-monitor)# mtu 512
switch(config-monitor)# destination interface Ethernet 1/39
switch(config-monitor)# no shut
switch(config-monitor)# show monitor session 5
  session 5
  -----
type           : local
state          : down (No operational src/dst)
mtu            : 512
source intf    :
  rx           : Eth1/5
  tx           : Eth1/5
  both        : Eth1/5
source VLANs   :
  rx           :
destination ports : Eth1/39
```

Legend: f = forwarding enabled, l = learning enabled

Displaying SPAN Information

SUMMARY STEPS

1. switch# **show monitor** [**session** {**all** | *session-number* | **range** *session-range*} [**brief**]]

DETAILED STEPS

	Command or Action	Purpose
Step 1	switch# show monitor [session { all <i>session-number</i> range <i>session-range</i> } [brief]]	Displays the SPAN configuration.

Example

The following example shows how to display SPAN session information:

```
switch# show monitor
SESSION STATE REASON DESCRIPTION
-----
2 up The session is up
3 down Session suspended
4 down No hardware resource
```

The following example shows how to display SPAN session details:

```
switch# show monitor session 2
session 2
-----
type : local
state : up
source intf :
source VLANs :
rx :
destination ports : Eth3/1
```



CHAPTER 14

Configuring Warp SPAN

This chapter contains the following sections:

- [Information About Warp SPAN, on page 175](#)
- [Guidelines and Limitations for Warp Span, on page 176](#)
- [Configuring Warp SPAN, on page 177](#)
- [Verifying Warp SPAN Mode Configuration, on page 178](#)
- [Feature History for Warp SPAN, on page 179](#)

Information About Warp SPAN

Warp SPAN is AlgoBoost feature that spans the traffic coming into a dedicated port to a group of ports at very low latency. In Warp SPAN, traffic arriving at one dedicated ingress port is replicated to a user configurable group of egress ports. The packet replication happens without any filters or lookup mechanisms. Unlike normal or Warp mode traffic forwarding, the incoming traffic is replicated before any traffic classification or ACL processing occurs. Because traffic bypasses these processes, the latency for the replicated packets is as low as 50ns. The Warp SPAN functions independently and simultaneously to normal traffic forwarding. For example, the incoming source traffic can be switched, routed, multicast replicated, and so on, while at the same time this incoming traffic is warp spanned to multiple destination ports.

The original traffic ingressing the dedicated source port is forwarded normally with nominal switch latency, along with the Warp SPAN traffic at about 50ns to the configured destination ports. Warp SPAN can be enabled both in normal traffic forwarding mode and Warp mode.

The source can be monitored only in the ingress direction and is not configurable. The source port is configured automatically as soon as you configure the Warp SPAN session.

You configure the dedicated source Layer 2/Layer 3 port (must be Ethernet port 1/36) with standard configuration as required by the network.

You configure destination ports similar to any regular SPAN destination port. The destination ports cannot be used as regular Layer 2/Layer 3 ports. Destination ports must be configured in groups of four, so you can create a maximum of 12 groups with a total of 47 destination ports (one port—port 1/36—is the fixed source port). See the following table.

Table 29: Warp SPAN Groups

Group	Destination Ports
1	1-4

Group	Destination Ports
2	5-8
3	9-12
4	13-16
5	17-20
6	21-24
7	25-28
8	29-32
9	33-35 1
10	37-40
11	41-44
12	45-48

¹ Port 36 is the dedicated source port.

Guidelines and Limitations for Warp Span

Warp SPAN has the following configuration guidelines and limitations:

- Source and destination Warp SPAN ports must all be 10G.
- The source port is not configurable and is fixed as Ethernet port 1/36.
- You can create a maximum of 12 groups with a total of 47 destination ports. All of the groups have four ports, except for group 9, which has only three ports and excludes port 1/36 (the fixed source port).
- All four ports in a group must be configured with the **switchport monitor** command before they can be grouped in a SPAN destination group.
- Warp SPAN does not allow the destination group to be configured unless all of the ports are administratively up. After the group has been configured, you can bring up or down any of the ports in the SPAN destination group. If you copy a working warp configuration that has one or more ports in the administratively down state and paste that configuration back in the configuration file of the same switch, Warp SPAN logs the following error:

```
ERROR: Cannot configure group with member interfaces in admin DOWN state
```
- The use of the same source interface on Warp SPAN and ERSPAN is not supported.

Configuring Warp SPAN

You configure Warp SPAN by enabling it and then configuring its destination groups.

SUMMARY STEPS

1. switch# **configure terminal**
2. switch(config-monitor)# **interface ethernet** *port/slot*
3. switch(config-if)# **switchport monitor**
4. switch(config-if)# **no shutdown**
5. switch(config)# **monitor session warp**
6. switch(config)# **no shutdown**
7. switch(config-monitor)# **destination group** *group-number*
8. (Optional) switch(config-if)# **copy running-config startup-config**

DETAILED STEPS

	Command or Action	Purpose
Step 1	switch# configure terminal	Enters global configuration mode.
Step 2	switch(config-monitor)# interface ethernet <i>port/slot</i>	Enters interface configuration mode for the specified interface. Note You can specify a range to configure multiple interfaces at once.
Step 3	switch(config-if)# switchport monitor	Sets the interface to monitor mode. Priority flow control (PFC) is disabled when the port is configured as a SPAN destination.
Step 4	switch(config-if)# no shutdown	Brings the interface administratively up.
Step 5	switch(config)# monitor session warp	Enables Warp SPAN on the interface.
Step 6	switch(config)# no shutdown	Brings the interface administratively up.
Step 7	switch(config-monitor)# destination group <i>group-number</i>	Configures the destination group. Note You can create a maximum of 12 groups with a total of 47 destination ports. All of the groups have four ports, except for group 9, which has only three ports and excludes port 1/36 (the fixed source port).
Step 8	(Optional) switch(config-if)# copy running-config startup-config	Saves the change persistently through reboots and restarts by copying the running configuration to the startup configuration.

Example

The following example shows how to configure destination SPAN ports 1/1-4 for Warp SPAN:

```
switch# configure terminal
switch(config-monitor)# interface ethernet 1/1-4
switch(config-if-range)# switchport monitor
switch(config-if-range)# no shutdown
switch(config)# monitor session warp
switch(config)# no shutdown
switch(config-monitor)# destination group 1
switch(config-if-range)# copy running-config startup-config
```

Verifying Warp SPAN Mode Configuration

You can verify the Warp SPAN mode configuration.

SUMMARY STEPS

1. switch(config)# **show monitor session** {*number* | **all** | *range*}
2. switch(config)# **show monitor session warp**

DETAILED STEPS

	Command or Action	Purpose
Step 1	switch(config)# show monitor session { <i>number</i> all <i>range</i> }	Displays information about a specific SPAN session, all SPAN sessions, or a range of SPAN sessions.
Step 2	switch(config)# show monitor session warp	Displays information about only the Warp SPAN sessions.

Example

This example shows how to display information about all SPAN sessions and only the Warp SPAN sessions:

```
switch(config)# show monitor session all
session warp
-----
type : local
state : up
source intf :
rx : Eth1/36
tx :
both :
source VLANs :
rx :
destination ports : Eth1/1 Eth1/2 Eth1/3 Eth1/4

Legend: f = forwarding enabled, l = learning enabled
```

```
switch(config)# show monitor session warp
session warp
-----
type : local
state : up
source intf :
rx : Eth1/36
tx :
both :
source VLANs :
rx :
destination ports : Eth1/1 Eth1/2 Eth1/3 Eth1/4

Legend: f = forwarding enabled, l = learning enabled
```

Feature History for Warp SPAN

Feature Name	Release	Feature Information
Warp SPAN	5.0(3)A1(2)	This feature was introduced.



CHAPTER 15

Configuring ERSPAN

This chapter contains the following sections:

- [Information About ERSPAN, on page 181](#)
- [Prerequisites for ERSPAN, on page 183](#)
- [Guidelines and Limitations for ERSPAN, on page 184](#)
- [Default Settings for ERSPAN, on page 185](#)
- [Configuring ERSPAN, on page 186](#)
- [Configuration Examples for ERSPAN, on page 199](#)
- [Additional References, on page 200](#)

Information About ERSPAN

The Cisco NX-OS system supports the Encapsulated Remote Switching Port Analyzer (ERSPAN) feature on both source and destination ports. ERSPAN transports mirrored traffic over an IP network.

ERSPAN consists of an ERSPAN source session, routable ERSPAN generic routing encapsulation (GRE)-encapsulated traffic, and an ERSPAN destination session. You can separately configure ERSPAN source sessions and destination sessions on different switches.

ERSPAN Types

ERSPAN Type III supports all of the ERSPAN Type II features and functionality and adds these enhancements:

- Provides timestamp information in the ERSPAN Type III header that can be used to calculate packet latency among edge, aggregate, and core switches.
- Identifies possible traffic sources using the ERSPAN Type III header fields.

ERSPAN Sources

The interfaces from which traffic can be monitored are called ERSPAN sources. Sources designate the traffic to monitor and whether to copy ingress, egress, or both directions of traffic. ERSPAN sources include the following:

- Ethernet ports and port channels.

- VLANs—When a VLAN is specified as an ERSPAN source, all supported interfaces in the VLAN are ERSPAN sources.

ERSPAN source ports have the following characteristics:

- A port configured as a source port cannot also be configured as a destination port.
- ERSPAN does not monitor any packets that are generated by the supervisor, regardless of their source.
- Ingress traffic at source ports can be filtered by using ACLs so that they mirror only those packets of information that match the ACL criteria.

ERSPAN Destinations

ERSPAN destination sessions capture packets sent by ERSPAN source sessions on Ethernet ports or port channels and send them to the destination port. Destination ports receive the copied traffic from ERSPAN sources.

ERSPAN destination sessions are identified by the configured source IP address and ERSPAN ID. This allows multiple source sessions to send ERSPAN traffic to the same destination IP and ERSPAN ID and allows you to have multiple sources terminating at a single destination simultaneously.

ERSPAN destination ports have the following characteristics:

- A port configured as a destination port cannot also be configured as a source port.
- Destination ports do not participate in any spanning tree instance or any Layer 3 protocols.
- Ingress and ingress learning options are not supported on monitor destination ports.
- Host Interface (HIF) port channels and fabric port channel ports are not supported as SPAN destination ports.

ERSPAN Sessions

You can create ERSPAN sessions that designate sources and destinations to monitor.

When configuring ERSPAN source sessions, you must configure the destination IP address. When configuring ERSPAN destination sessions, you must configure the source IP address. See [ERSPAN Sources, on page 181](#) for the properties of source sessions and [ERSPAN Destinations, on page 182](#) for the properties of destination sessions.



Note Only eight unidirectional, or four bidirectional ERSPAN or SPAN source sessions can run simultaneously across all switches. Only 20 ERSPAN destination sessions can run simultaneously across all switches.

The following figure shows an ERSPAN configuration.

Figure 1: ERSPAN Configuration

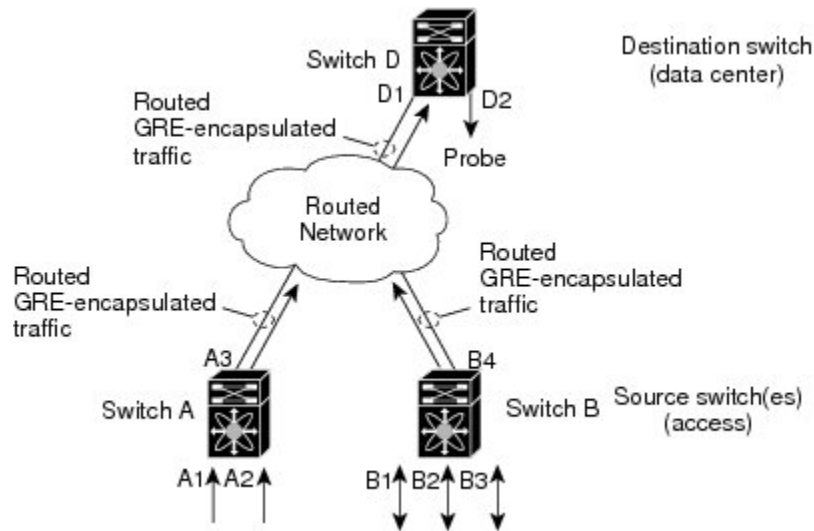

Multiple ERSPAN Sessions

You can define up to eight unidirectional ERSPAN source or SPAN sessions, or four bidirectional ERSPAN source or SPAN sessions at one time. You can shut down any unused ERSPAN sessions.

For information about shutting down ERSPAN sessions, see [Shutting Down or Activating an ERSPAN Session, on page 191](#).

ERSPAN Marker Packet

The type III ERSPAN header carries a hardware generated 32-bit timestamp. This timestamp field wraps periodically. When the switch is set to 1 ns granularity, this field wraps every 4.29 seconds. Such a wrap time makes it difficult to interpret the real value of the timestamp.

To recover the real value of the ERSPAN timestamp, Cisco NX-OS Release 6.0(2)A4(1) introduces a periodical marker packet to carry the original UTC timestamp information and provide a reference for the ERSPAN timestamp. The marker packet is sent out in 1-second intervals. Therefore, the destination site can detect the 32-bit wrap by checking the difference between the timestamp of the reference packet and the packet order.

High Availability

The ERSPAN feature supports stateless and stateful restarts. After a reboot or supervisor switchover, the running configuration is applied.

Prerequisites for ERSPAN

ERSPAN has the following prerequisite:

- You must first configure the Ethernet interfaces for ports on each device to support the desired ERSPAN configuration. For more information, see the Interfaces configuration guide for your platform.

Guidelines and Limitations for ERSPAN

ERSPAN has the following configuration guidelines and limitations:

- ERSPAN supports the following:
 - ERSPAN source session type (Packets are encapsulated as GRE-tunnel packets and sent on the IP network.)
 - ERSPAN destination session type (Support for decapsulating the ERSPAN packet is available. The encapsulated packet is decapsulated at the destination box and the plain decapsulated packet is spanned to a front panel port at the ERSPAN terminating point.)
- ERSPAN source sessions are shared with local SPAN sessions. You can configure a maximum of eight ERSPAN source or SPAN source sessions in a single direction; If both receive and transmit sources are configured in the same session, it counts as two sessions and you can configure four such bidirectional sessions at one time.
- If you install Cisco NX-OS 5.0(3)U2(2), configure ERSPAN, and then downgrade to a lower version of software, the ERSPAN configuration is lost. This situation occurs because ERSPAN is not supported in versions before Cisco NX-OS 5.0(3)U2(2).

For information about a similar SPAN limitation, see [Guidelines and Limitations for SPAN, on page 159](#).

- ERSPAN is not supported for packets generated by the supervisor.
- ERSPAN sessions are terminated identically at the destination router.
- ERSPAN is not supported for management ports.
- A destination port can be configured in multiple ERSPAN session at a time.
- You cannot configure a port as both a source and destination port.
- A single ERSPAN session can include mixed sources in any combination of the following:
 - Ethernet ports or port channels but not subinterfaces.
 - VLANs or port channels, which can be assigned to port channel subinterfaces.
 - The port channels to the control plane CPU.



Note ERSPAN does not monitor any packets that are generated by the supervisor, regardless of their source.

- Destination ports do not participate in any spanning tree instance or Layer 3 protocols.
- When an ERSPAN session contains source ports that are monitored in the transmit or transmit and receive direction, packets that these ports receive may be replicated to the ERSPAN destination port even though the packets are not actually transmitted on the source ports. Some examples of this behavior on source ports include:
 - Traffic that results from flooding

- Broadcast and multicast traffic
- When Nexus 3548 is the ERSPAN destination, GRE headers are stripped off before sending mirrored packets out of the terminating point.
- ERSPAN does not support 1588 granularity mode, and rejects this mode if selected.
- ERSPAN supports 100 microseconds (μ s), 100 nanoseconds (ns), and ns granularity.
- ERSPAN sends all timestamps in 32-bit format. Therefore, the timestamp field will wrap periodically. When the switch is set to ns granularity, this field will wrap every 4.29 seconds.
- A Layer 3 subinterface cannot be configured as an ERSPAN source interface.
- All ERSPAN sources terminating in a single destination box must use the same destination IP address.
- You cannot configure different source IP addresses in different ERSPAN destination sessions.
- Layer 3 switched traffic from VLAN X to VLAN Y, which is spanned through the ERSPAN source in either the Rx or Tx direction, will carry VLAN information in the ERSPAN header of VLAN X (the VLAN before Layer 3 switching or ingress VLAN).
- Multicast flood packets that do not go out of the ERSPAN source interface, which is configured for the egress (Tx) direction, can still reach the ERSPAN destination. This is because egress spanned packets are spanned before the original egress port is selectively enabled to receive specific frames and drop others, whereas the span for the Nexus 3548 switch application-specific integrated circuit (ASIC) is based on the monitor port's property. As a result, the spanned packet is still sent to the remote destination. This is expected behavior from platforms specific to multicast flood and is not seen for other traffic streams.
- Replicated multicast packets sent out of the ERSPAN source in the Tx direction are not sent to the ERSPAN destination.
- You can monitor the same source interfaces (physical port or port-channel) in multiple ERSPAN (type 2 or type 3) sessions.
- Configuring IP Filter on ERSPAN or Local SPAN with VLAN as source is not supported.

Default Settings for ERSPAN

The following table lists the default settings for ERSPAN parameters.

Table 30: Default ERSPAN Parameters

Parameters	Default
ERSPAN sessions	Created in the shut state.

Configuring ERSPAN

Configuring an ERSPAN Source Session

You can configure an ERSPAN session on the local device only. By default, ERSPAN sessions are created in the shut state.

For sources, you can specify Ethernet ports, port channels, and VLANs. A single ERSPAN session can include mixed sources in any combination of Ethernet ports or VLANs.



Note ERSPAN does not monitor any packets that are generated by the supervisor, regardless of their source.

SUMMARY STEPS

1. **configure terminal**
2. **monitor erspan origin ip-address** *ip-address* **global**
3. **monitor erspan granularity** **100_ns** {**100_us**|**100_ns**|**ns**}
4. **no monitor session** {*session-number* | **all**}
5. **monitor session** {*session-number* | **all**} **type erspan-source**
6. **header-type** *version*
7. **description** *description*
8. **source** {[**interface**[*type slot/port*[-*port*][, *type slot/port*[-*port*]]] [**port-channel** *channel-number*]] | [**vlan** {*number* | *range*}]} [**rx** | **tx** | **both**]
9. (Optional) Repeat Step 6 to configure all ERSPAN sources.
10. **destination ip** *ip-address*
11. **erspan-id** *erspan-id*
12. **vrf** *vrf-name*
13. (Optional) **ip ttl** *ttl-number*
14. (Optional) **ip dscp** *dscp-number*
15. **no shut**
16. (Optional) **show monitor session** {**all** | *session-number* | **range** *session-range*}
17. (Optional) **show running-config monitor**
18. (Optional) **show startup-config monitor**
19. (Optional) **copy running-config startup-config**

DETAILED STEPS

	Command or Action	Purpose
Step 1	configure terminal Example: <pre>switch# config t switch(config)#</pre>	Enters global configuration mode.

	Command or Action	Purpose
Step 2	monitor erspan origin ip-address <i>ip-address</i> global Example: <pre>switch(config)# monitor erspan origin ip-address 10.0.0.1 global</pre>	Configures the ERSPAN global origin IP address.
Step 3	monitor erspan granularity 100_ns{100_us 100_ns ns} Example: <pre>switch(config)# monitor erspan granularity 100_ns</pre>	Configures the granularity of all ERSPAN sessions.
Step 4	no monitor session {<i>session-number</i> all} Example: <pre>switch(config)# no monitor session 3</pre>	Clears the configuration of the specified ERSPAN session. The new session configuration is added to the existing session configuration.
Step 5	monitor session {<i>session-number</i> all} type erspan-source Example: <pre>switch(config)# monitor session 3 type erspan-source switch(config-erspan-src)#</pre>	Configures an ERSPAN source session.
Step 6	header-type <i>version</i> Example: <pre>switch(config-erspan-src)# header-type 3</pre>	(Optional) Changes the ERSPAN source session from Type II to Type III.
Step 7	description <i>description</i> Example: <pre>switch(config-erspan-src)# description erspan_src_session_3</pre>	Configures a description for the session. By default, no description is defined. The description can be up to 32 alphanumeric characters.
Step 8	source {[<i>interface</i>[<i>type slot/port</i>[-<i>port</i>][, <i>type slot/port</i>[-<i>port</i>]]] [<i>port-channel channel-number</i>]} [<i>vlan {number range}</i>]} [<i>rx</i> <i>tx</i> <i>both</i>] Example: <pre>switch(config-erspan-src)# source interface ethernet 2/1-3, ethernet 3/1 rx</pre> Example: <pre>switch(config-erspan-src)# source interface port-channel 2</pre> Example: <pre>switch(config-erspan-src)# source interface sup-eth 0 both</pre> Example: <pre>switch(config-monitor)# source interface ethernet 101/1/1-3</pre>	
Step 9	(Optional) Repeat Step 6 to configure all ERSPAN sources.	—

	Command or Action	Purpose
Step 10	destination ip <i>ip-address</i> Example: switch(config-erspan-src)# destination ip 10.1.1.1	Configures the destination IP address in the ERSPAN session. Only one destination IP address is supported per ERSPAN source session.
Step 11	erspan-id <i>erspan-id</i> Example: switch(config-erspan-src)# erspan-id 5	Configures the ERSPAN ID for the ERSPAN source session. The ERSPAN range is from 1 to 1023. This ID uniquely identifies a source and destination ERSPAN session pair. The ERSPAN ID configured in the corresponding destination ERSPAN session must be same as the one configured in the source session.
Step 12	vrf <i>vrf-name</i> Example: switch(config-erspan-src)# vrf default	Configures the VRF that the ERSPAN source session uses for traffic forwarding.
Step 13	(Optional) ip ttl <i>tll-number</i> Example: switch(config-erspan-src)# ip ttl 25	Configures the IP time-to-live (TTL) value for the ERSPAN traffic. The range is from 1 to 255.
Step 14	(Optional) ip dscp <i>dscp-number</i> Example: switch(config-erspan-src)# ip dscp 42	Configures the differentiated services code point (DSCP) value of the packets in the ERSPAN traffic. The range is from 0 to 63.
Step 15	no shut Example: switch(config-erspan-src)# no shut	Enables the ERSPAN source session. By default, the session is created in the shut state. Note Only two ERSPAN source sessions can be running simultaneously.
Step 16	(Optional) show monitor session { all <i>session-number</i> range <i>session-range</i> } Example: switch(config-erspan-src)# show monitor session 3	Displays the ERSPAN session configuration.
Step 17	(Optional) show running-config monitor Example: switch(config-erspan-src)# show running-config monitor	Displays the running ERSPAN configuration.
Step 18	(Optional) show startup-config monitor Example: switch(config-erspan-src)# show startup-config monitor	Displays the ERSPAN startup configuration.
Step 19	(Optional) copy running-config startup-config Example:	Copies the running configuration to the startup configuration.

	Command or Action	Purpose
	switch(config-erspan-src)# copy running-config startup-config	

Configuring an ERSPAN Destination Session

You can configure an ERSPAN destination session to copy packets from a source IP address to destination ports on the local device. By default, ERSPAN destination sessions are created in the shut state.

Before you begin

Ensure that you have already configured the destination ports in monitor mode.

SUMMARY STEPS

1. **config t**
2. **interface ethernet** *slot/port[-port]*
3. **switchport**
4. **switchport mode** [access | trunk]
5. **switchport monitor**
6. Repeat Steps 2 to 5 to configure monitoring on additional ERSPAN destinations.
7. **no monitor session** {*session-number* | all}
8. **monitor session** {*session-number* | all} **type erspan-destination**
9. **description** *description*
10. **source ip** *ip-address*
11. **destination** {[**interface** [*type slot/port[-port]*, [*type slot/port [port]*]]}
12. **erspan-id** *erspan-id*
13. **no shut**
14. (Optional) **show monitor session** {all | *session-number* | range *session-range*}
15. (Optional) **show running-config monitor**
16. (Optional) **show startup-config monitor**
17. (Optional) **copy running-config startup-config**

DETAILED STEPS

	Command or Action	Purpose
Step 1	config t Example: switch# config t switch(config)#	Enters global configuration mode.
Step 2	interface ethernet <i>slot/port[-port]</i> Example: switch(config)# interface ethernet 2/5 switch(config-if)#	Enters interface configuration mode on the selected slot and port or range of ports.

	Command or Action	Purpose
Step 3	switchport Example: switch(config-if)# switchport	Configures switchport parameters for the selected slot and port or range of ports.
Step 4	switchport mode [access trunk] Example: switch(config-if)# switchport mode trunk	Configures the following switchport modes for the selected slot and port or range of ports: <ul style="list-style-type: none"> • access • trunk
Step 5	switchport monitor Example: switch(config-if)# switchport monitor	Configures the switch interface in monitor mode. To configure an interface to be an ERSPAN or SPAN destination (using the destination interface ethernet interface command), it must first be configured in monitor mode.
Step 6	Repeat Steps 2 to 5 to configure monitoring on additional ERSPAN destinations.	—
Step 7	no monitor session {session-number all} Example: switch(config-if)# no monitor session 3	Clears the configuration of the specified ERSPAN session. The new session configuration is added to the existing session configuration.
Step 8	monitor session {session-number all} type erspan-destination Example: switch(config-if)# monitor session 3 type erspan-destination switch(config-erspan-dst)#	Configures an ERSPAN destination session.
Step 9	description description Example: switch(config-erspan-dst)# description erspan_dst_session_3	Configures a description for the session. By default, no description is defined. The description can be up to 32 alphanumeric characters.
Step 10	source ip ip-address Example: switch(config-erspan-dst)# source ip 10.1.1.1	Configures the source IP address in the ERSPAN session. Only one source IP address is supported per ERSPAN destination session. This IP address must match the destination IP address that is configured in the corresponding ERSPAN source session.
Step 11	destination {[interface [type slot/port[-port], [type slot/port [port]]]} Example: switch(config-erspan-dst)# destination interface ethernet 2/5	Configures a destination for copied source packets. You can configure only interfaces as a destination. Note You can configure destination ports as trunk ports.

	Command or Action	Purpose
Step 12	erspan-id <i>erspan-id</i> Example: <pre>switch(config-erspan-dst)# erspan-id 5</pre>	Configures the ERSPAN ID for the ERSPAN session. The range is from 1 to 1023. This ID uniquely identifies a source and destination ERSPAN session pair. The ERSPAN ID configured in the corresponding destination ERSPAN session must be same as the one configured in the source session.
Step 13	no shut Example: <pre>switch(config)# no shut</pre>	Enables the ERSPAN destination session. By default, the session is created in the shut state. Note Only 16 active ERSPAN destination sessions can be running simultaneously.
Step 14	(Optional) show monitor session { all <i>session-number</i> range <i>session-range</i> } Example: <pre>switch(config)# show monitor session 3</pre>	Displays the ERSPAN session configuration.
Step 15	(Optional) show running-config monitor Example: <pre>switch(config-erspan-src)# show running-config monitor</pre>	Displays the running ERSPAN configuration.
Step 16	(Optional) show startup-config monitor Example: <pre>switch(config-erspan-src)# show startup-config monitor</pre>	Displays the ERSPAN startup configuration.
Step 17	(Optional) copy running-config startup-config Example: <pre>switch(config-erspan-src)# copy running-config startup-config</pre>	Copies the running configuration to the startup configuration.

Shutting Down or Activating an ERSPAN Session

You can shut down ERSPAN sessions to discontinue the copying of packets from sources to destinations. Because only a specific number of ERSPAN sessions can be running simultaneously, you can shut down a session to free hardware resources to enable another session. By default, ERSPAN sessions are created in the shut state.

You can enable ERSPAN sessions to activate the copying of packets from sources to destinations. To enable an ERSPAN session that is already enabled but operationally down, you must first shut it down and then enable it. You can shut down and enable the ERSPAN session states with either a global or monitor configuration mode command.

SUMMARY STEPS

1. **configuration terminal**
2. **monitor session** {*session-range* | **all**} **shut**

3. **no monitor session** *{session-range | all}* **shut**
4. **monitor session** *session-number* **type** *erspan-source*
5. **monitor session** *session-number* **type** *erspan-destination*
6. **shut**
7. **no shut**
8. (Optional) **show monitor session all**
9. (Optional) **show running-config monitor**
10. (Optional) **show startup-config monitor**
11. (Optional) **copy running-config startup-config**

DETAILED STEPS

	Command or Action	Purpose
Step 1	configuration terminal Example: <pre>switch# configuration terminal switch(config)#</pre>	Enters global configuration mode.
Step 2	monitor session <i>{session-range all}</i> shut Example: <pre>switch(config)# monitor session 3 shut</pre>	Shuts down the specified ERSPAN sessions. The session range is from 1 to 48.. By default, sessions are created in the shut state.
Step 3	no monitor session <i>{session-range all}</i> shut Example: <pre>switch(config)# no monitor session 3 shut</pre>	Resumes (enables) the specified ERSPAN sessions. The session range is from 1 to 48.. By default, sessions are created in the shut state. . Note If a monitor session is enabled but its operational status is down, then to enable the session, you must first specify the monitor session shut command followed by the no monitor session shut command.
Step 4	monitor session <i>session-number</i> type <i>erspan-source</i> Example: <pre>switch(config)# monitor session 3 type erspan-source switch(config-erspan-src)#</pre>	Enters the monitor configuration mode for the ERSPAN source type. The new session configuration is added to the existing session configuration.
Step 5	monitor session <i>session-number</i> type <i>erspan-destination</i> Example: <pre>switch(config-erspan-src)# monitor session 3 type erspan-destination</pre>	Enters the monitor configuration mode for the ERSPAN destination type.
Step 6	shut Example: <pre>switch(config-erspan-src)# shut</pre>	Shuts down the ERSPAN session. By default, the session is created in the shut state.

	Command or Action	Purpose
Step 7	no shut Example: switch(config-erspan-src)# no shut	Enables the ERSPAN session. By default, the session is created in the shut state.
Step 8	(Optional) show monitor session all Example: switch(config-erspan-src)# show monitor session all	Displays the status of ERSPAN sessions.
Step 9	(Optional) show running-config monitor Example: switch(config-erspan-src)# show running-config monitor	Displays the running ERSPAN configuration.
Step 10	(Optional) show startup-config monitor Example: switch(config-erspan-src)# show startup-config monitor	Displays the ERSPAN startup configuration.
Step 11	(Optional) copy running-config startup-config Example: switch(config-erspan-src)# copy running-config startup-config	Copies the running configuration to the startup configuration.

Configuring ERSPAN Filtering

You can configure SPAN filters for local and ERSPAN-source sessions only. [SPAN and ERSPAN Filtering, on page 161](#) provides more information about filters.

SUMMARY STEPS

1. switch# **configure terminal**
2. switch(config)# **monitor session** {*session-number* | **all**} **type erspan-source**
3. switch(config-erspan-src)# **filter** {**ip** *source-ip-address source-ip-mask destination-ip-address destination-ip-mask*}
4. switch(config-erspan-src)# **erspan-id** *erspan-id*
5. switch(config-erspan-src)# **vrf** *vrf-name*
6. switch(config-erspan-src)# **destination ip** *ip-address*
7. switch(config-erspan-src)# **source** [**interface** [*type slot/port*] | **port-channel** *channel-number*] | [**vlan** *vlan-range*] [**rx** | **tx** | **both**]

DETAILED STEPS

	Command or Action	Purpose
Step 1	switch# configure terminal	Enters global configuration mode.

	Command or Action	Purpose
Step 2	switch(config)# monitor session { <i>session-number</i> all } type erspan-source	Configures an ERSPAN source session.
Step 3	switch(config-erspan-src)# filter { ip <i>source-ip-address</i> <i>source-ip-mask destination-ip-address destination-ip-mask</i> }	Creates an ERSPAN filter.
Step 4	switch(config-erspan-src)# erspan-id <i>erspan-id</i>	Configures the ERSPAN ID for the ERSPAN source session. The ERSPAN range is from 1 to 1023. This ID uniquely identifies a source and destination ERSPAN session pair. The ERSPAN ID configured in the corresponding destination ERSPAN session must be same as the one configured in the source session.
Step 5	switch(config-erspan-src)# vrf <i>vrf-name</i>	Configures the VRF that the ERSPAN source session uses for traffic forwarding.
Step 6	switch(config-erspan-src)# destination ip <i>ip-address</i>	Configures the destination IP address in the ERSPAN session. Only one destination IP address is supported per ERSPAN source session.
Step 7	switch(config-erspan-src)# source [interface <i>type slot/port</i> port-channel <i>channel-number</i>] [vlan <i>vlan-range</i>] [rx tx both]	Configures the sources and traffic direction in which to copy packets. You can enter a range of Ethernet ports, a port channel, or a range of VLANs. You can configure one or more sources, as either a series of comma-separated entries or a range of numbers. You can specify up to 128 interfaces. You can specify the traffic direction to copy as ingress, egress, or both. The default direction is both.

Example

The following example shows how to configure a MAC-based filter for an ERSPAN-source session:

```
switch# configure terminal
Enter configuration commands, one per line. End with CNTL/Z.
switch(config)# monitor session 2 type erspan-source
switch(config-erspan-src)# filter abcd.ef12.3456 1111.2222.3333 1234.5678.9012 1111.2222.3333
switch(config-erspan-src)# erspan-id 20
switch(config-erspan-src)# vrf default
switch(config-erspan-src)# destination ip 200.1.1.1
switch(config-erspan-src)# source interface Ethernet 1/47 rx
switch(config-erspan-src)# no shut
switch(config-erspan-src)#
```

The following example shows how to configure a VLAN-based filter for an ERSPAN-source session:

```
switch# configure terminal
Enter configuration commands, one per line. End with CNTL/Z.
switch(config)# monitor session 2 type erspan-source
switch(config-erspan-src)# filter abcd.ef12.3456 1111.2222.3333 1234.5678.9012 1111.2222.3333
switch(config-erspan-src)# erspan-id 21
switch(config-erspan-src)# vrf default
switch(config-erspan-src)# destination ip 200.1.1.1
switch(config-erspan-src)# source interface Ethernet 1/47 rx
```

```
switch(config-erspan-src) # source vlan 315
switch(config-erspan-src) # mtu 200
switch(config-erspan-src) # no shut
switch(config-erspan-src) #
```

Configuring ERSPAN Sampling

You can configure sampling for local and ERSPAN-source sessions only. [SPAN and ERSPAN Sampling, on page 163](#) provides more information about sampling.

SUMMARY STEPS

1. switch# **configure terminal**
2. switch(config)# **monitor session** {*session-number* | **all**} **type erspan-source**
3. switch(config-erspan-src)# **sampling** *sampling-range*
4. switch(config-erspan-src)# **erspan-id** *erspan-id*
5. switch(config-erspan-src)# **vrf** *vrf-name*
6. switch(config-erspan-src)# **destination ip** *ip-address*
7. switch(config-erspan-src)# **source** [**interface** *type slot/port* | **port-channel** *channel-number*] | [**vlan** *vlan-range*] [**rx** | **tx** | **both**]

DETAILED STEPS

	Command or Action	Purpose
Step 1	switch# configure terminal	Enters global configuration mode.
Step 2	switch(config)# monitor session { <i>session-number</i> all } type erspan-source	Configures an ERSPAN source session.
Step 3	switch(config-erspan-src)# sampling <i>sampling-range</i>	Configures a range for spanning packets. If the range is defined as n, every nth packet will be spanned. The sampling range is between 2 and 1023.
Step 4	switch(config-erspan-src)# erspan-id <i>erspan-id</i>	Configures the ERSPAN ID for the ERSPAN source session. The ERSPAN range is from 1 to 1023. This ID uniquely identifies a source and destination ERSPAN session pair. The ERSPAN ID configured in the corresponding destination ERSPAN session must be same as the one configured in the source session.
Step 5	switch(config-erspan-src)# vrf <i>vrf-name</i>	Configures the VRF that the ERSPAN source session uses for traffic forwarding.
Step 6	switch(config-erspan-src)# destination ip <i>ip-address</i>	Configures the destination IP address in the ERSPAN session. Only one destination IP address is supported per ERSPAN source session.
Step 7	switch(config-erspan-src)# source [interface <i>type slot/port</i> port-channel <i>channel-number</i>] [vlan <i>vlan-range</i>] [rx tx both]	Configures the sources and traffic direction in which to copy packets. You can enter a range of Ethernet ports, a port channel, or a range of VLANs.

	Command or Action	Purpose
		<p>You can configure one or more sources, as either a series of comma-separated entries or a range of numbers. You can specify up to 128 interfaces.</p> <p>You can specify the traffic direction to copy as ingress, egress, or both. The default direction is both.</p>

Example

The following example shows how to configure sampling for an ERSPAN-source session:

```

switch# configure terminal
Enter configuration commands, one per line. End with CNTL/Z.
switch(config)# monitor session 2 type erspan-source
switch(config-erspan-src)# sampling 40
switch(config-erspan-src)# erspan-id 30
switch(config-erspan-src)# vrf default
switch(config-erspan-src)# destination ip 200.1.1.1
switch(config-erspan-src)# source interface ethernet 1/47
switch(config-erspan-src)# show monitor session 2
session 2
-----
type : erspan-source
state : up
granularity : 100 microseconds
erspan-id : 30
vrf-name : default
destination-ip : 200.1.1.1
ip-ttl : 255
ip-dscp : 0
header-type : 2
mtu : 200
sampling : 40
origin-ip : 150.1.1.1 (global)
source intf :
rx : Eth1/47
tx : Eth1/47
both : Eth1/47
source VLANs :
rx : 315
switch(config-erspan-src)#

```

Configuring ERSPAN Truncation

You can configure truncation for local and ERSPAN-source sessions only. [SPAN and ERSPAN Truncation, on page 163](#) provides more information about truncation.

SUMMARY STEPS

1. switch# **configure terminal**
2. switch(config)# **monitor session {session-number | all} type erspan-source**
3. switch(config-erspan-src)# **mtu size**
4. switch(config-erspan-src)# **erspan-id erspan-id**

5. switch(config-erspan-src)# **vrf** *vrf-name*
6. switch(config-erspan-src)# **destination ip** *ip-address*
7. switch(config-erspan-src)# **source** [**interface** *type slot/port* | **port-channel** *channel-number*] | [**vlan** *vlan-range*] [**rx** | **tx** | **both**]

DETAILED STEPS

	Command or Action	Purpose
Step 1	switch# configure terminal	Enters global configuration mode.
Step 2	switch(config)# monitor session { <i>session-number</i> all } type erspan-source	Configures an ERSPAN source session.
Step 3	switch(config-erspan-src)# mtu size	Configures the MTU size for truncation. Any SPAN packet that is larger than the configured MTU size is truncated to the configured size with a 4-byte offset. The MTU truncation size is between 64 bytes and 1518 bytes.
Step 4	switch(config-erspan-src)# erspan-id <i>erspan-id</i>	Configures the ERSPAN ID for the ERSPAN source session. The ERSPAN range is from 1 to 1023. This ID uniquely identifies a source and destination ERSPAN session pair. The ERSPAN ID configured in the corresponding destination ERSPAN session must be same as the one configured in the source session.
Step 5	switch(config-erspan-src)# vrf <i>vrf-name</i>	Configures the VRF that the ERSPAN source session uses for traffic forwarding.
Step 6	switch(config-erspan-src)# destination ip <i>ip-address</i>	Configures the destination IP address in the ERSPAN session. Only one destination IP address is supported per ERSPAN source session.
Step 7	switch(config-erspan-src)# source [interface <i>type slot/port</i> port-channel <i>channel-number</i>] [vlan <i>vlan-range</i>] [rx tx both]	Configures the sources and traffic direction in which to copy packets. You can enter a range of Ethernet ports, a port channel, or a range of VLANs. You can configure one or more sources, as either a series of comma-separated entries or a range of numbers. You can specify up to 128 interfaces. You can specify the traffic direction to copy as ingress, egress, or both. The default direction is both.

Example

The following example shows how to configure MTU truncation for an ERSPAN-source session:

```
switch# configure terminal
switch(config)# monitor session 6 type erspan-source
switch(config-erspan-src)# mtu 1096
switch(config-erspan-src)# erspan-id 40
switch(config-erspan-src)# vrf default
```

```

switch(config-erspan-src)# destination ip 200.1.1.1
switch(config-erspan-src)# source interface ethernet 1/40
switch(config-erspan-src)# show monitor session 6
session 6
-----
type : erspan-source
state : down (Session admin shut)
granularity : 100 microseconds
erspan-id : 40
vrf-name : default
destination-ip : 200.1.1.1
ip-ttl : 255
ip-dscp : 0
header-type : 2
mtu : 1096
origin-ip : 150.1.1.1 (global)
source intf :
rx : Eth1/40
tx : Eth1/40
both : Eth1/40
source VLANs :
rx :

```

Configuring an ERSPAN Marker Packet

Use the following commands to configure an ERSPAN marker packet:

Command	Purpose
marker-packet seconds	Enables the ERSPAN marker packet for a session. The interval can range from 1 second to 4 seconds.
marker-packet milliseconds	Enables the ERSPAN marker packet for a session. The interval can range from 100 milliseconds to 900 milliseconds, with increments in multiples of 100.
no marker-packet	Disables the ERSPAN marker packet for a session.

Example

This example shows how to enable the ERSPAN marker packet with an interval of 2 seconds:



Note Configuring the interval parameter is optional. If you enable the marker-packet without specifying a parameter, it uses the default or existing interval as the interval value. The **marker-packet** command only enables the marker-packet.

```

switch# configure terminal
switch(config)# monitor erspan origin ip-address 172.28.15.250 global
switch(config)# monitor session 1 type erspan-source
switch(config)# header-type 3
switch(config-erspan-src)# erspan-id 1
switch(config-erspan-src)# ip ttl 16

```

```

switch(config-erspan-src) # ip dscp 5
switch(config-erspan-src) # vrf default
switch(config-erspan-src) # destination ip 9.1.1.2
switch(config-erspan-src) # source interface e1/15 both
switch(config-erspan-src) # marker-packet 2
switch(config-erspan-src) # no shut
switch(config-erspan-src) # exit

```

Verifying the ERSPAN Configuration

Use the following command to verify the ERSPAN configuration information:

Command	Purpose
show monitor session {all session-number range session-range}	Displays the ERSPAN session configuration.
show running-config monitor	Displays the running ERSPAN configuration.
show startup-config monitor	Displays the ERSPAN startup configuration.

Configuration Examples for ERSPAN

Configuration Example for an ERSPAN Source Session

The following example shows how to configure an ERSPAN source session:

```

switch# config t
switch(config) # interface e14/30
switch(config-if) # no shut
switch(config-if) # exit
switch(config) # monitor erspan origin ip-address 3.3.3.3 global
switch(config) # monitor erspan granularity 100_ns
switch(config-erspan-src) # header-type 3
switch(config) # monitor session 1 type erspan-source
switch(config-erspan-src) # source interface e14/30
switch(config-erspan-src) # erspan-id 1
switch(config-erspan-src) # ip ttl 16
switch(config-erspan-src) # ip dscp 5
switch(config-erspan-src) # destination ip 9.1.1.2
switch(config-erspan-src) # no shut
switch(config-erspan-src) # exit
switch(config) # show monitor session 1

```



Note `switch(config) # monitor erspan granularity 100_ns` and `switch(config-erspan-src) # header-type 3` are used only while configuring Type III source sessions.

Configuration Example for an ERSPAN Destination Session

The following example shows how to configure an ERSPAN destination session:

```
switch# config t
switch(config)# interface e14/29
switch(config-if)# no shut
switch(config-if)# switchport
switch(config-if)# switchport monitor
switch(config-if)# exit
switch(config)# monitor session 2 type erspan-destination
switch(config-erspan-dst)# source ip 9.1.1.2
switch(config-erspan-dst)# destination interface e14/29
switch(config-erspan-src)# erspan-id 1
switch(config-erspan-dst)# no shut
switch(config-erspan-dst)# exit
switch(config)# show monitor session 2
```

Additional References

Related Documents

Related Topic	Document Title
ERSPAN commands: complete command syntax, command modes, command history, defaults, usage guidelines, and examples	<i>Cisco Nexus NX-OS System Management Command Reference</i> for your platform.



CHAPTER 16

Configuring DNS

This chapter contains the following sections:

- [Information About DNS Client](#) , on page 201
- [Prerequisites for DNS Clients](#), on page 202
- [Default Settings for DNS Clients](#), on page 202
- [Configuring DNS Clients](#), on page 202

Information About DNS Client

If your network devices require connectivity with devices in networks for which you do not control name assignment, you can assign device names that uniquely identify your devices within the entire internetwork using the domain name server (DNS). DNS uses a hierarchical scheme for establishing hostnames for network nodes, which allows local control of the segments of the network through a client-server scheme. The DNS system can locate a network device by translating the hostname of the device into its associated IP address.

On the Internet, a domain is a portion of the naming hierarchy tree that refers to general groupings of networks based on the organization type or geography. Domain names are pieced together with periods (.) as the delimiting characters. For example, Cisco is a commercial organization that the Internet identifies by a com domain, so its domain name is cisco.com. A specific hostname in this domain, the File Transfer Protocol (FTP) system, for example, is identified as ftp.cisco.com.

Name Servers

Name servers keep track of domain names and know the parts of the domain tree for which they have complete information. A name server may also store information about other parts of the domain tree. To map domain names to IP addresses in Cisco NX-OS, you must first identify the hostnames, then specify a name server, and enable the DNS service.

Cisco NX-OS allows you to statically map IP addresses to domain names. You can also configure Cisco NX-OS to use one or more domain name servers to find an IP address for a hostname.

DNS Operation

A name server handles client-issued queries to the DNS server for locally defined hosts within a particular zone as follows:

- An authoritative name server responds to DNS user queries for a domain name that is under its zone of authority by using the permanent and cached entries in its own host table. If the query is for a domain name that is under its zone of authority but for which it does not have any configuration information, the authoritative name server replies that no such information exists.
- A name server that is not configured as the authoritative name server responds to DNS user queries by using information that it has cached from previously received query responses. If no router is configured as the authoritative name server for a zone, queries to the DNS server for locally defined hosts receive nonauthoritative responses.

Name servers answer DNS queries (forward incoming DNS queries or resolve internally generated DNS queries) according to the forwarding and lookup parameters configured for the specific domain.

High Availability

Cisco NX-OS supports stateless restarts for the DNS client. After a reboot or supervisor switchover, Cisco NX-OS applies the running configuration.

Prerequisites for DNS Clients

The DNS client has the following prerequisites:

- You must have a DNS name server on your network.

Default Settings for DNS Clients

The following table shows the default settings for DNS client parameters.

Parameter	Default
DNS client	Enabled

Configuring DNS Clients

You can configure the DNS client to use a DNS server on your network.

Before you begin

Ensure that you have a domain name server on your network.

SUMMARY STEPS

1. switch# **configuration terminal**
2. switch(config)# vrf context management
3. switch(config)# **ip host name address1 [address2... address6]**
4. (Optional) switch(config)# **ip domain name name [use-vrf vrf-name]**
5. (Optional) switch(config)# **ip domain-list name [use-vrf vrf-name]**

6. (Optional) switch(config)# **ip name-server** *server-address1* [*server-address2... server-address6*] [**use-vrf** *vrf-name*]
7. (Optional) switch(config)# **ip domain-lookup**
8. (Optional) switch(config)# **show hosts**
9. switch(config)# **exit**
10. (Optional) switch# **copy running-config startup-config**

DETAILED STEPS

	Command or Action	Purpose
Step 1	switch# configuration terminal	Enters global configuration mode.
Step 2	switch(config)# vrf context management	Specifies a configurable virtual and routing (VRF) name.
Step 3	switch(config)# ip host <i>name address1</i> [<i>address2... address6</i>]	Defines up to six static hostname-to-address mappings in the host name cache.
Step 4	(Optional) switch(config)# ip domain name <i>name</i> [use-vrf <i>vrf-name</i>]	Defines the default domain name server that Cisco NX-OS uses to complete unqualified hostnames. You can optionally define a VRF that Cisco NX-OS uses to resolve this domain name server if it cannot be resolved in the VRF that you configured this domain name under. Cisco NX-OS appends the default domain name to any host name that does not contain a complete domain name before starting a domain-name lookup.
Step 5	(Optional) switch(config)# ip domain-list <i>name</i> [use-vrf <i>vrf-name</i>]	Defines additional domain name servers that Cisco NX-OS can use to complete unqualified hostnames. You can optionally define a VRF that Cisco NX-OS uses to resolve this domain name server if it cannot be resolved in the VRF that you configured this domain name under. Cisco NX-OS uses each entry in the domain list to append that domain name to any hostname that does not contain a complete domain name before starting a domain-name lookup. Cisco NX-OS continues this for each entry in the domain list until it finds a match.
Step 6	(Optional) switch(config)# ip name-server <i>server-address1</i> [<i>server-address2... server-address6</i>] [use-vrf <i>vrf-name</i>]	Defines up to six name servers. The address can be either an IPv4 address or an IPv6 address. You can optionally define a VRF that Cisco NX-OS uses to reach this name server if it cannot be reached in the VRF that you configured this name server under.
Step 7	(Optional) switch(config)# ip domain-lookup	Enables DNS-based address translation. This feature is enabled by default.
Step 8	(Optional) switch(config)# show hosts	Displays information about DNS.
Step 9	switch(config)# exit	Exits configuration mode and returns to EXEC mode.

	Command or Action	Purpose
Step 10	(Optional) switch# copy running-config startup-config	Copies the running configuration to the startup configuration.

Example

The following example shows how to configure a default domain name and enable DNS lookup:

```
switch# config t  
switch(config)# vrf context management  
switch(config)# ip domain-name mycompany.com  
switch(config)# ip name-server 172.68.0.10  
switch(config)# ip domain-lookup
```



CHAPTER 17

Configuring Traffic Forwarding Modes

This chapter contains the following sections:

- [Information About Warp Mode, on page 205](#)
- [Guidelines and Limitations for Warp Mode, on page 205](#)
- [Enabling and Disabling Warp Mode, on page 206](#)
- [Verifying Warp Mode Status, on page 206](#)
- [Feature History for Warp Mode, on page 207](#)

Information About Warp Mode

The Cisco Nexus device uses a hardware component called the Algorithm Boost Engine (Algo Boost Engine) to support a forwarding mechanism, called warp mode. In warp mode, the access path is shortened by consolidating the forwarding table into single table, resulting in faster processing of frames and packets. In warp mode, latency is reduced by up to 20 percent. For more information about the Algo Boost Engine, see [Active Buffer Monitoring Overview, on page 209](#).

Guidelines and Limitations for Warp Mode

Warp mode has the following configuration guidelines and limitations:

- Warp mode provides up to 20 percent better switch latency than normal forwarding.
- In warp mode, unicast route tables are reduced. The route table is reduced from 24000 to 4000 entries. The host table and MAC table are reduced from 64000 to 8000 entries. (The multicast route table remains the same at 8000 entries.)
- In warp mode, the following features are not supported:
 - Egress Routed Access Control Lists (RACLs)
 - Port Access Control Lists (PACLs)
 - Equal-cost Multipathing (ECMP)
 - IP Redirect

Enabling and Disabling Warp Mode

SUMMARY STEPS

1. switch# **configure terminal**
2. switch(config)# **hardware profile forwarding-mode warp**
3. (Optional) switch(config)# **copy running-config startup-config**
4. Reload the switch.

DETAILED STEPS

	Command or Action	Purpose
Step 1	switch# configure terminal	Enters global configuration mode.
Step 2	switch(config)# hardware profile forwarding-mode warp	Enables warp mode on the device. To disable warp mode, use the no form of this command. The default is warp mode disabled.
Step 3	(Optional) switch(config)# copy running-config startup-config	Saves the change persistently through reboots and restarts by copying the running configuration to the startup configuration.
Step 4	Reload the switch.	—

Example

This example shows how to enable warp mode on the device:

```
switch# configuration terminal
switch(config)# hardware profile forwarding-mode warp
Warning: This command will take effect only after saving the configuration (copy r s)
switch(config)# copy running-config startup-config
switch(config)#
```

This example shows how to disable warp mode on the device:

```
switch# configuration terminal
switch(config)# no hardware profile forwarding-mode warp
Warning: This command will take effect only after saving the configuration (copy r s)
switch(config)# copy running-config startup-config
```

Verifying Warp Mode Status

SUMMARY STEPS

1. switch# **show hardware profile forwarding-mode**

DETAILED STEPS

	Command or Action	Purpose
Step 1	switch# show hardware profile forwarding-mode	Displays information about warp mode and the host, unicast, multicast, and Layer 2 ternary content addressable memory (TCAM) sizes.

Example

This example shows how to display information about warp mode:

```
switch# show hardware profile forwarding-mode
=====
forwarding-mode : warp
=====
host      size  = 8192
unicast   size  = 4096
multicast size  = 8192
l2        size  = 8192
switch#
```

Feature History for Warp Mode

Feature Name	Release	Feature Information
Warp Mode	5.0(3)A1(1)	This feature was introduced.



CHAPTER 18

Configuring Active Buffer Monitoring

This chapter contains the following sections:

- [Information About Active Buffer Monitoring, on page 209](#)
- [Configuring Active Buffer Monitoring, on page 210](#)
- [Displaying Buffer Histogram Data, on page 211](#)

Information About Active Buffer Monitoring

Active Buffer Monitoring Overview

The Active Buffer Monitoring feature provides detailed buffer occupancy data to help you detect network congestion, review past events to understand when and how network congestion is affecting network operations, understand historical trending, and identify patterns of application traffic flow.

A hardware component, called the Algorithm Boost Engine (Algo Boost Engine) supports buffer histogram counters for unicast buffer usage per individual port, total buffer usage per buffer block, and multicast buffer usage per buffer block. Each histogram counter has 18 buckets that span across the memory block. The Algo Boost Engine polls buffer usage data every hardware sampling interval (the default is every 4 milliseconds, but you can configure it to be as low as 10 nanoseconds). Based on the buffer utilization, the corresponding histogram counter is incremented. For example, if Ethernet port 1/4 is consuming 500 KB of the buffer, the bucket 2 counter (which represents 384 KB to 768 KB) for Ethernet 1/4 is incremented.

To avoid a counter overflow, the Cisco NX-OS software collects the histogram data every polling interval and maintains it in the system memory. The software maintains the histogram data in the system memory for the last 60 minutes with 1-second granularity. Every hour, the software copies the buffer histogram data from the system memory to the bootflash as a backup.

The Active Buffer Monitoring feature has two modes of operation:

- **Unicast mode**—The Algo Boost Engine monitors and maintains a buffer histogram for total buffer utilization per buffer block and unicast buffer utilization for all 48 ports.
- **Multicast mode**—The Algo Boost Engine monitors and maintains buffer histogram data for total buffer utilization per buffer block and multicast buffer utilization per buffer block.

Buffer Histogram Data Access and Collection

After active buffer monitoring is enabled, the device maintains 70 minutes of data—the first 60 minutes (0 to 60 minutes) in the log and another 60 minutes (10 to 70 minutes) in memory.

You can access buffer histogram data using several methods:

- You can access it from the system memory using **show** commands.
- You can integrate the Active Buffer Monitoring feature with Cisco NX-OS Python scripting to collect historical data by copying the data to a server regularly.
- You can access the buffer histogram data using an XML interface.
- You can configure Cisco NX-OS to log a message in the syslog whenever the buffer occupancy exceeds the configured threshold.

Configuring Active Buffer Monitoring



Note If you use NX-API over the front panel port, you must increase the CoPP policy (for HTTP) to allow 3000 PPS traffic. Doing so prevents packet drops, and the CLIs, creating larger outputs, return within the expected time.

SUMMARY STEPS

1. switch# **configure terminal**
2. switch(config)# **hardware profile buffer monitor {unicast | multicast}**
3. switch(config)# **hardware profile buffer monitor {unicast | multicast} threshold *threshold-value***
4. switch(config)# **hardware profile buffer monitor {unicast | multicast} sampling *sampling-value***
5. (Optional) switch(config)# **copy running-config startup-config**

DETAILED STEPS

	Command or Action	Purpose
Step 1	switch# configure terminal	Enters global configuration mode.
Step 2	switch(config)# hardware profile buffer monitor {unicast multicast}	Enables the hardware profile buffer for either unicast or multicast traffic.
Step 3	switch(config)# hardware profile buffer monitor {unicast multicast} threshold <i>threshold-value</i>	Generates a syslog entry when the specified maximum buffer size is exceeded. The range is 384–6144 kilobytes with 384-kilobyte increments. The default is 90 percent of the total available shared buffer.
Step 4	switch(config)# hardware profile buffer monitor {unicast multicast} sampling <i>sampling-value</i>	Specifies to sample data at the specified interval. Range is 10–20,000,000 nanoseconds. The default sampling value is 4 milliseconds.

	Command or Action	Purpose
Step 5	(Optional) <code>switch(config)# copy running-config startup-config</code>	Saves the change persistently through reboots and restarts by copying the running configuration to the startup configuration.

Example

This example shows how to configure Active Buffer Monitoring for unicast traffic. A threshold value of 384 kilobytes and a sampling value of 5000 nanoseconds is used:

```
switch# configure terminal
switch(config)# hardware profile buffer monitor unicast
switch(config)# hardware profile buffer monitor unicast threshold 384
switch(config)# hardware profile buffer monitor unicast sampling 5000
switch(config)# copy running-config startup-config
```

The following example shows how to configure Active Buffer Monitoring for multicast traffic. A threshold value of 384 kilobytes and a sampling value of 5000 nanoseconds is used.

```
switch# configure terminal
switch(config)# hardware profile buffer monitor multicast
switch(config)# hardware profile buffer monitor multicast threshold 384
switch(config)# hardware profile buffer monitor multicast sampling 5000
switch(config)# copy running-config startup-config
```

Displaying Buffer Histogram Data

SUMMARY STEPS

1. `switch# show hardware profile buffer monitor [interface ethernet slot/port] {brief | buffer-block | detail | multicast | summary}`
2. (Optional) `switch# clear hardware profile buffer monitor`

DETAILED STEPS

	Command or Action	Purpose
Step 1	<code>switch# show hardware profile buffer monitor [interface ethernet slot/port] {brief buffer-block detail multicast summary}</code>	<p>Displays data collected about the buffer. The keywords are defined as follows:</p> <ul style="list-style-type: none"> • brief—Specifies to show limited information about each interface. • buffer-block—Specifies to display information about a specific buffer block. • detail—Specifies to display all information gathered for each interface. • interface—(Optional) Specifies to display information about a specific port.

	Command or Action	Purpose
		<ul style="list-style-type: none"> • multicast—Specifies to show buffer data for multicast traffic only. • summary—Specifies to display summary information about each buffer block. <p>Note The show command option interface is only valid in unicast mode and the multicast option is only valid in multicast mode.</p>
Step 2	(Optional) switch# clear hardware profile buffer monitor	Clears the collected buffer data.

Example

This example shows how to display summary information for each buffer block and for all of the buffers combined:

```
switch# show hardware profile buffer monitor summary
Summary CLI issued at: 09/18/2012 07:38:39

                Maximum buffer utilization detected
                1sec    5sec    60sec    5min    1hr
                -----
Buffer Block 1    0KB     0KB     0KB     0KB     N/A

Total Shared Buffer Available = 5049 Kbytes
Class Threshold Limit = 4845 Kbytes
=====
Buffer Block 2    0KB     0KB     0KB     0KB     N/A

Total Shared Buffer Available = 5799 Kbytes
Class Threshold Limit = 5598 Kbytes
=====
Buffer Block 3    0KB     0KB    5376KB    5376KB    N/A

Total Shared Buffer Available = 5799 Kbytes
Class Threshold Limit = 5598 Kbytes
```

This example shows how to display the maximum buffer utilization of each buffer block and each interface for unicast mode:

```
switch# show hardware profile buffer monitor brief
Brief CLI issued at: 09/18/2012 07:38:29

                Maximum buffer utilization detected
                1sec    5sec    60sec    5min    1hr
                -----
Buffer Block 1    0KB     0KB     0KB     0KB     N/A

Total Shared Buffer Available = 5049 Kbytes
Class Threshold Limit = 4845 Kbytes
-----
Ethernet1/45     0KB     0KB     0KB     0KB     N/A
Ethernet1/46     0KB     0KB     0KB     0KB     N/A
```

```

Ethernet1/47      0KB      0KB      0KB      0KB      N/A
Ethernet1/48      0KB      0KB      0KB      0KB      N/A
Ethernet1/21      0KB      0KB      0KB      0KB      N/A
Ethernet1/22      0KB      0KB      0KB      0KB      N/A
Ethernet1/23      0KB      0KB      0KB      0KB      N/A
Ethernet1/24      0KB      0KB      0KB      0KB      N/A
Ethernet1/9       0KB      0KB      0KB      0KB      N/A
Ethernet1/10      0KB      0KB      0KB      0KB      N/A
Ethernet1/11      0KB      0KB      0KB      0KB      N/A
Ethernet1/12      0KB      0KB      0KB      0KB      N/A
Ethernet1/33      0KB      0KB      0KB      0KB      N/A
Ethernet1/34      0KB      0KB      0KB      0KB      N/A
Ethernet1/35      0KB      0KB      0KB      0KB      N/A
Ethernet1/36      0KB      0KB      0KB      0KB      N/A

```

```

=====
Buffer Block 2    0KB      0KB      0KB      0KB      N/A

```

```

Total Shared Buffer Available = 5799 Kbytes
Class Threshold Limit = 5598 Kbytes
-----

```

```

Ethernet1/17      0KB      0KB      0KB      0KB      N/A
Ethernet1/18      0KB      0KB      0KB      0KB      N/A
Ethernet1/19      0KB      0KB      0KB      0KB      N/A
Ethernet1/20      0KB      0KB      0KB      0KB      N/A
Ethernet1/5       0KB      0KB      0KB      0KB      N/A
Ethernet1/6       0KB      0KB      0KB      0KB      N/A
Ethernet1/7       0KB      0KB      0KB      0KB      N/A
Ethernet1/8       0KB      0KB      0KB      0KB      N/A
Ethernet1/41      0KB      0KB      0KB      0KB      N/A
Ethernet1/42      0KB      0KB      0KB      0KB      N/A
Ethernet1/43      0KB      0KB      0KB      0KB      N/A
Ethernet1/44      0KB      0KB      0KB      0KB      N/A
Ethernet1/29      0KB      0KB      0KB      0KB      N/A
Ethernet1/30      0KB      0KB      0KB      0KB      N/A
Ethernet1/31      0KB      0KB      0KB      0KB      N/A
Ethernet1/32      0KB      0KB      0KB      0KB      N/A

```

```

=====
Buffer Block 3    0KB      0KB      5376KB   5376KB   N/A

```

```

Total Shared Buffer Available = 5799 Kbytes
Class Threshold Limit = 5598 Kbytes
-----

```

```

Ethernet1/13      0KB      0KB      0KB      0KB      N/A
Ethernet1/14      0KB      0KB      0KB      0KB      N/A
Ethernet1/15      0KB      0KB      0KB      0KB      N/A
Ethernet1/16      0KB      0KB      0KB      0KB      N/A
Ethernet1/37      0KB      0KB      0KB      0KB      N/A
Ethernet1/38      0KB      0KB      0KB      0KB      N/A
Ethernet1/39      0KB      0KB      0KB      0KB      N/A
Ethernet1/40      0KB      0KB      0KB      0KB      N/A
Ethernet1/25      0KB      0KB      0KB      0KB      N/A
Ethernet1/26      0KB      0KB      0KB      0KB      N/A
Ethernet1/27      0KB      0KB      0KB      0KB      N/A
Ethernet1/28      0KB      0KB      0KB      0KB      N/A
Ethernet1/1       0KB      0KB      0KB      0KB      N/A
Ethernet1/2       0KB      0KB      0KB      0KB      N/A
Ethernet1/3       0KB      0KB      0KB      0KB      N/A
Ethernet1/4       0KB      0KB      5376KB   5376KB   N/A

```

This example shows how to display the maximum buffer utilization information of each buffer block for multicast mode:

```

switch# show hardware profile buffer monitor brief
Brief CLI issued at: 09/18/2012 08:30:08

                Maximum buffer utilization detected
                1sec    5sec    60sec    5min    1hr
                -----
Buffer Block 1    0KB     0KB     0KB     0KB     0KB

Total Shared Buffer Available = 5049 Kbytes
Class Threshold Limit = 4845 Kbytes
Mcast Usage 1    0KB     0KB     0KB     0KB     0KB
=====
Buffer Block 2    0KB     0KB     0KB     0KB     0KB

Total Shared Buffer Available = 5799 Kbytes
Class Threshold Limit = 5598 Kbytes
Mcast Usage 2    0KB     0KB     0KB     0KB     0KB
=====
Buffer Block 3    0KB     0KB     0KB     0KB     0KB

Total Shared Buffer Available = 5799 Kbytes
Class Threshold Limit = 5598 Kbytes
Mcast Usage 3    0KB     0KB     0KB     0KB     0KB

```

The following example shows how to display detailed buffer utilization information of buffer block 3 for multicast mode:

```

switch# show hardware profile buffer monitor multicast 3 detail
Detail CLI issued at: 09/18/2012 08:30:12

Legend -
384KB - between 1 and 384KB of shared buffer consumed by port
768KB - between 385 and 768KB of shared buffer consumed by port
307us - estimated max time to drain the buffer at 10Gbps

Active Buffer Monitoring for Mcast Usage 3 is: Active
KBytes          384  768 1152 1536 1920 2304 2688 3072 3456 3840 4224 4608 4992 5376
 5760 6144
us @ 10Gbps     307  614  921 1228 1535 1842 2149 2456 2763 3070 3377 3684 3991 4298
 4605 4912
-----
----
09/18/2012 08:30:12    0  0  0  0  0  0  0  0  0  0  0  0  0  0
0  0  0
09/18/2012 08:30:11    0  0  0  0  0  0  0  0  0  0  0  0  0  0
0  0  0
09/18/2012 08:30:10    0  0  0  0  0  0  0  0  0  0  0  0  0  0
0  0  0
09/18/2012 08:30:09    0  0  0  0  0  0  0  0  0  0  0  0  0  0
0  0  0
09/18/2012 08:30:08    0  0  0  0  0  0  0  0  0  0  0  0  0  0
0  0  0
09/18/2012 08:30:07    0  0  0  0  0  0  0  0  0  0  0  0  0  0
0  0  0
09/18/2012 08:30:06    0  0  0  0  0  0  0  0  0  0  0  0  0  0
0  0  0
09/18/2012 08:30:05    0  0  0  0  0  0  0  0  0  0  0  0  0  0
0  0  0
09/18/2012 08:30:04    0  0  0  0  0  0  0  0  0  0  0  0  0  0
0  0  0

```

```
09/18/2012 08:30:03      0  0  0  0  0  0  0  0  0  0  0  0  0  0
0  0  0
```

The following example shows how to display detailed buffer data about Ethernet interface 1/4:

```
switch# show hardware profile buffer monitor interface ethernet 1/4 detail
Detail CLI issued at: 09/18/2012 07:38:43
```

```
Legend -
384KB - between 1 and 384KB of shared buffer consumed by port
768KB - between 385 and 768KB of shared buffer consumed by port
307us - estimated max time to drain the buffer at 10Gbps
```

```
Active Buffer Monitoring for port Ethernet1/4 is: Active
KBytes      384  768 1152 1536 1920 2304 2688 3072 3456 3840 4224 4608 4992 5376
5760 6144
us @ 10Gbps  307  614  921 1228 1535 1842 2149 2456 2763 3070 3377 3684 3991 4298
4605 4912
```

```
-----
---- ----
09/18/2012 07:38:42      0  0  0  0  0  0  0  0  0  0  0  0  0  0
0  0  0
09/18/2012 07:38:41      0  0  0  0  0  0  0  0  0  0  0  0  0  0
0  0  0
09/18/2012 07:38:40      0  0  0  0  0  0  0  0  0  0  0  0  0  0
0  0  0
09/18/2012 07:38:39      0  0  0  0  0  0  0  0  0  0  0  0  0  0
0  0  0
09/18/2012 07:38:38      0  0  0  0  0  0  0  0  0  0  0  0  0  0
0  0  0
09/18/2012 07:38:37      0  0  0  0  0  0  0  0  0  0  0  0  0  0
0  0  0
09/18/2012 07:38:36      0  0  0  0  0  0  0  0  0  0  0  0  0  0
0  0  0
09/18/2012 07:38:35      0  0  0  0  0  0  0  0  0  0  0  0  0  0
0  0  0
09/18/2012 07:38:34      0  0  0  0  0  0  0  0  0  0  0  0  0  0
0  0  0
09/18/2012 07:38:33      0  0  0  0  0  0  0  0  0  0  0  0  0  0
0  0  0
09/18/2012 07:38:32      0  0  0  0  0  0  0  0  0  0  0  0  0  0
0  0  0
09/18/2012 07:38:31      0  0  0  0  0  0  0  0  0  0  0  0  0  0
0  0  0
09/18/2012 07:38:30      0  0  0  0  0  0  0  0  0  0  0  0  0  0
0  0  0
09/18/2012 07:38:29      0  0  0  0  0  0  0  0  0  0  0  0  0  0
0  0  0
09/18/2012 07:38:28      0  0  0  0  0  0  0  0  0  0  0  0  0  0
0  0  0
09/18/2012 07:38:27      0  0  0  0  0  0  0  0  0  0  0  0  0  0
0  0  0
09/18/2012 07:38:26      0  0  0  0  0  0  0  0  0  0  0  0  0  0
0  0  0
09/18/2012 07:38:25      0  0  0  0  0  0  0  0  0  0  0  0  0  0
0  0  0
09/18/2012 07:38:24      0  0  0  0  0  0  0  0  0  0  0  0  0  0
0  0  0
09/18/2012 07:38:23      0  0  0  0  0  0  0  0  0  0  0  0  0  0
0  0  0
09/18/2012 07:38:22      0  0  0  0  0  0  0  0  0  0  0  0  0  0
0  0  0
09/18/2012 07:38:21      0  0  0  0  0  0  0  0  0  0  0  0  0  0
0  0  0
09/18/2012 07:38:20     177  36  0  0  0  0  0  0  0  0  0  0  0  0
```

Displaying Buffer Histogram Data

```

0      0      0
09/18/2012 07:38:19      0 143 107      0      0      0      0      0      0      0      0      0      0
0      0      0
09/18/2012 07:38:18      0      0      72 178      3      0      0      0      0      0      0      0      0
0      0      0
09/18/2012 07:38:17      0      0      0      0 176      74      0      0      0      0      0      0      0
0      0      0
09/18/2012 07:38:16      0      0      0      0      0 105 145      0      0      0      0      0      0
0      0      0
09/18/2012 07:38:15      0      0      0      0      0      0 33 179 38      0      0      0      0
0      0      0
09/18/2012 07:38:14      0      0      0      0      0      0      0      0 140 113      0      0      0
0      0      0
09/18/2012 07:38:13      0      0      0      0      0      0      0      0      0 66 178      6      0
0      0      0
09/18/2012 07:38:12      0      0      0      0      0      0      0      0      0      0      0 173 77
0      0      0
09/18/2012 07:38:11      1      0      0      1      0      0      1      0      0      1      0      0 102
42      0      0
09/18/2012 07:38:10      0      0      0      0      0      0      0      0      0      0      0      0      0
0      0      0

```



CHAPTER 19

Performing Software Maintenance Upgrades (SMUs)

This chapter includes the following sections:

- [About SMUs, on page 217](#)
- [Package Management, on page 218](#)
- [Prerequisites for SMUs, on page 218](#)
- [Guidelines and Limitations for SMUs, on page 219](#)
- [Performing a Software Maintenance Upgrade for Cisco NX-OS, on page 219](#)
- [Preparing for Package Installation, on page 219](#)
- [Copying the Package File to a Local Storage Device or Network Server, on page 220](#)
- [Adding and Activating Packages, on page 221](#)
- [Committing the Active Package Set, on page 222](#)
- [Deactivating and Removing Packages, on page 223](#)
- [Displaying Installation Log Information, on page 224](#)

About SMUs

A software maintenance upgrade (SMU) is a package file that contains fixes for a specific defect. SMUs are created to respond to immediate issues and do not include new features. Typically, SMUs do not have a large impact on device operations. SMU versions are synchronized to the package major, minor, and maintenance versions they upgrade.

The effect of an SMU depends on its type:

- **Process restart SMU**-Causes a process or group of processes to restart on activation.
- **Reload SMU**-Causes a parallel reload of supervisors and line cards.

SMUs are not an alternative to maintenance releases. They provide a quick resolution of immediate issues. All defects fixed by SMUs are integrated into the maintenance releases.

For information on upgrading your device to a new feature or maintenance release, see the *Cisco Nexus 3500 Series NX-OS Software Upgrade and Downgrade Guide*.



Note Activating an SMU does not cause any earlier SMUs, or the package to which the SMU applies, to be automatically deactivated.

Package Management

The general procedure for adding and activating SMU packages on the device is as follows:

1. Copy the package file or files to a local storage device or file server.
2. Add the package or packages on the device using the **install add** command.
3. Activate the package or packages on the device using the **install activate** command.
4. Commit the current set of packages using the **install commit** command.
5. (Optional) Deactivate and remove the package, when desired.

The following figure illustrates the key steps in the package management process.

Figure 2: Process to Add, Activate, and Commit SMU Packages

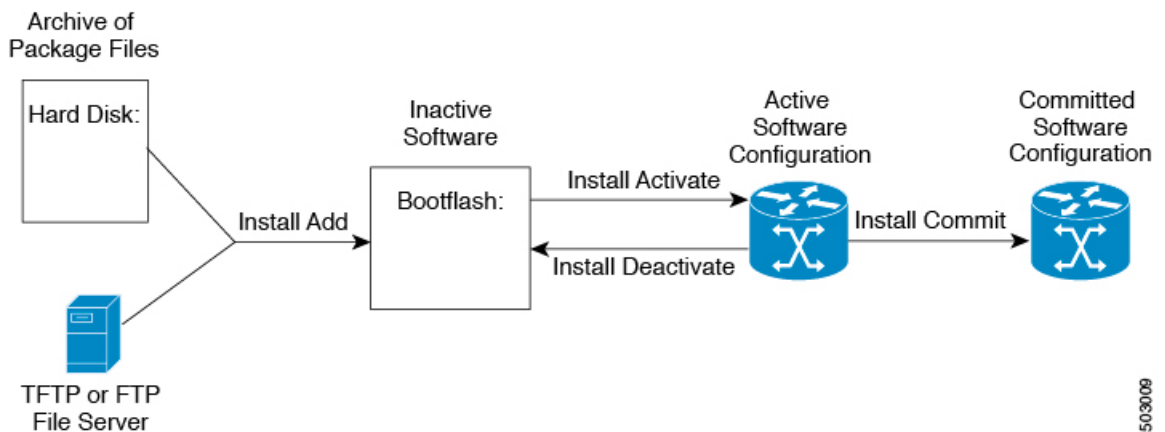

Prerequisites for SMUs

These prerequisites must be met for a package to be activated or deactivated:

- You must be in a user group associated with a task group that includes the proper task IDs. If you suspect a user group assignment is preventing you from using a command, contact your AAA administrator for assistance.
- Verify that all line cards are installed and operating properly. For example, do not activate or deactivate packages while line cards are booting, while line cards are being upgraded or replaced, or when you anticipate an automatic switchover activity.

Guidelines and Limitations for SMUs

SMUs have the following guidelines and limitations:

- Some packages require the activation or deactivation of other packages. If the SMUs have dependencies on each other, you cannot activate them without first activating the previous ones.
- The package being activated must be compatible with the current active software set.
- You cannot activate multiple SMUs in one command.
- Activation is performed only after the package compatibility checks have been passed. If a conflict is found, an error message displays.
- While a software package is being activated, other requests are not allowed to run on any of the impacted nodes. Package activation is completed when a message similar to this one appears:

```
Install operation 1 completed successfully at Thu Jan 9 01:19:24 2014
```
- Each CLI install request is assigned a request ID, which can be used later to review the events.
- If you perform a software maintenance upgrade and later upgrade your device to a new Cisco Nexus 3500 software release, the new image will overwrite both the previous Cisco Nexus 3500 release and the SMU package file.

Performing a Software Maintenance Upgrade for Cisco NX-OS

Preparing for Package Installation

You should use several **show** commands to gather information in preparation for the SMU package installation.

Before you begin

Determine if a software change is required.

Verify that the new package is supported on your system. Some software packages require that other packages or package versions be activated, and some packages support only specific line cards.

Review the release notes for important information related to that release and to help determine the package compatibility with your device configuration.

Verify that the system is stable and prepared for the software changes.

SUMMARY STEPS

1. **show install active**
2. **show module**
3. **show clock**

DETAILED STEPS

	Command or Action	Purpose
Step 1	show install active Example: switch# show install active	Displays the active software on the device. Use this command to determine what software should be added on the device and to compare to the active software report after installation operations are complete.
Step 2	show module Example: switch# show module	Confirms that all modules are in the stable state.
Step 3	show clock Example: switch# show clock	Verifies that the system clock is correct. Software operations use certificates based on device clock times.

Example

This example shows how to display the active packages for the entire system. Use this information to determine if a software change is required.

```
switch# show install active
Active Packages:
Active Packages on Module #3:

Active Packages on Module #6:

Active Packages on Module #7:
Active Packages on Module #22:

Active Packages on Module #30:
```

This example shows how to display the current system clock setting:

```
switch# show clock
02:14:51.474 PST Wed Jan 04 2014
```

Copying the Package File to a Local Storage Device or Network Server

You must copy the SMU package file to a local storage device or a network file server to which the device has access. After this task is done, the package can be added and activated on the device.

If you need to store package files on the device, we recommend that you store the files on the hard disk. The boot device is the local disk from which the package is added and activated. The default boot device is bootflash:.



Tip Before you copy package files to a local storage device, use the **dir** command to determine if the required package files are already on the device.

If the SMU package files are located on a remote TFTP, FTP, or SFTP server, you can copy the files to a local storage device. After the files are located on the local storage device, the package can be added and activated on the device from that storage device. The following server protocols are supported:

- Trivial File Transfer Protocol—TFTP allows files to be transferred from one computer to another over a network, usually without the use of client authentication (for example, username and password). It is a simplified version of FTP.



Note Some package files might be larger than 32 MB, and the TFTP services provided by some vendors might not support a file this large. If you do not have access to a TFTP server that supports files larger than 32 MB, download the file using FTP.

- File Transfer Protocol—FTP is part of the TCP/IP protocol stack and requires a username and password.
- SSH File Transfer Protocol—SFTP is part of the SSHv2 feature in the security package and provides for secure file transfers.

After the SMU package file has been transferred to a network file server or the local storage device, you are ready to add and activate the file.

Adding and Activating Packages

You can add SMU package files that are stored on a local storage device or on a remote TFTP, FTP, or SFTP server to your device.



Note The SMU package being activated must be compatible with the currently active software to operate. When an activation is attempted, the system runs an automatic compatibility check to ensure that the package is compatible with the other active software on the device. If a conflict is found, an error message displays. The activation is performed only after all compatibility checks have been passed.

SUMMARY STEPS

1. **install add** *filename* [**activate**]
2. (Optional) **show install inactive**
3. **install activate** *filename* [**test**]
4. Repeat Step 3 until all packages are activated.
5. (Optional) **show install active**

DETAILED STEPS

	Command or Action	Purpose
Step 1	<p>install add <i>filename</i> [activate]</p> <p>Example:</p> <pre>switch# install add bootflash: n3500-uk9.6.0.2.U6.0.1.CSCab00001.bin</pre>	<p>Unpacks the package software files from the local storage device or network server and adds them to the bootflash; and all active and standby supervisors installed on the device.</p> <p>The <i>filename</i> argument can take any of these formats:</p> <ul style="list-style-type: none"> • bootflash:<i>filename</i> • tftp://<i>hostname-or-ipaddress/directory-path/filename</i> • ftp://<i>username:password@hostname-or-ipaddress/directory-path/filename</i> • sftp://<i>hostname-or-ipaddress/directory-path/filename</i>
Step 2	<p>(Optional) show install inactive</p> <p>Example:</p> <pre>switch# show install inactive</pre>	<p>Displays the inactive packages on the device. Verify that the package added in the previous step appears in the display.</p>
Step 3	<p>Required: install activate <i>filename</i> [test]</p> <p>Example:</p> <pre>switch# install activate n3500-uk9.6.0.2.U6.0.1.CSCab00001.bin</pre> <p>Example:</p> <pre>switch# install activate n3500-uk9.6.0.2.U6.0.1.CSCab00001.bin Install operation 1 completed successfully at Thu Jan 9 01:27:56 2014</pre> <p>Example:</p> <pre>switch# install activate n3500-uk9.6.0.2.U6.0.1.CSCab00001.bin Install operation 2 !!WARNING!! This patch will get activated only after a reload of the switch. at Sun Mar 9 00:42:12 2014</pre>	<p>Activates a package that was added to the device. SMU packages remain inactive until activated. (Skip this step if the package was activated earlier with the install add activate command.)</p> <p>Note Press ? after a partial package name to display all possible matches available for activation. If there is only one match, press the Tab key to fill in the rest of the package name.</p>
Step 4	Repeat Step 3 until all packages are activated.	Activates additional packages as required.
Step 5	<p>(Optional) show install active</p> <p>Example:</p> <pre>switch# show install active</pre>	<p>Displays all active packages. Use this command to determine if the correct packages are active.</p>

Committing the Active Package Set

When an SMU package is activated on the device, it becomes part of the current running configuration. To make the package activation persistent across system-wide reloads, you must commit the package on the device.

SUMMARY STEPS

1. **install commit** *filename*
2. (Optional) **show install committed**

DETAILED STEPS

	Command or Action	Purpose
Step 1	install commit <i>filename</i> Example: <pre>switch# install commit n3500-uk9.6.0.2.U6.0.1.CSCab00001.bin</pre>	Commits the current set of packages so that these packages are used if the device is restarted.
Step 2	(Optional) show install committed Example: <pre>switch# show install committed</pre>	Displays which packages are committed.

Deactivating and Removing Packages

When a package is deactivated, it is no longer active on the device, but the package files remain on the boot disk. The package files can be reactivated later, or they can be removed from the disk.

SUMMARY STEPS

1. **install deactivate** *filename*
2. (Optional) **show install inactive**
3. (Optional) **install commit**
4. (Optional) **install remove** *{filename | inactive}*

DETAILED STEPS

	Command or Action	Purpose
Step 1	install deactivate <i>filename</i> Example: <pre>switch# install deactivate n3500-uk9.6.0.2.U6.0.1.CSCab00001.bin</pre>	Deactivates a package that was added to the device and turns off the package features for the line card. Note Press ? after a partial package name to display all possible matches available for deactivation. If there is only one match, press the Tab key to fill in the rest of the package name.
Step 2	(Optional) show install inactive Example: <pre>switch# show install inactive</pre>	Displays the inactive packages on the device.
Step 3	(Optional) install commit Example:	Commits the current set of packages so that these packages are used if the device is restarted.

	Command or Action	Purpose
	switch# install commit	Note Packages can be removed only if the deactivation operation is committed.
Step 4	<p>(Optional) install remove {filename inactive}</p> <p>Example:</p> <pre>switch# install remove n3500-uk9.6.0.2.U6.0.1.CSCab00001.bin Proceed with removing n3500-uk9.6.0.2.U6.0.1.CSCab00001.bin? (y/n)? [n] y</pre> <p>Example:</p> <pre>switch# install remove inactive Proceed with removing? (y/n)? [n] y</pre>	<p>Removes the inactive package.</p> <ul style="list-style-type: none"> • Only inactive packages can be removed. • Packages can be removed only if they are deactivated from all line cards in the device. • The package deactivation must be committed. • To remove a specific inactive package from a storage device, use the install remove command with the <i>filename</i> argument. • To remove all inactive packages from all nodes in the system, use the install remove command with the inactive keyword.

Displaying Installation Log Information

The installation log provides information on the history of the installation operations. Each time an installation operation is run, a number is assigned to that operation.

- Use the **show install log** command to display information about both successful and failed installation operations.
- Use the **show install log** command with no arguments to display a summary of all installation operations. Specify the *request-id* argument to display information specific to an operation. Use the **detail** keyword to display details for a specific operation, including file changes, nodes that could not be reloaded, and any impact to processes.

This example shows how to display information for all installation requests:

```
switch# show install log
Thu Jan 9 01:26:09 2014
Install operation 1 by user 'admin' at Thu Jan 9 01:19:19 2018
Install add bootflash: n3500-uk9.6.0.2.U6.0.1.CSCab00001.bin
Install operation 1 completed successfully at Thu Jan 9 01:19:24 2014
-----
Install operation 2 by user 'admin' at Thu Jan 9 01:19:29 2018
Install activate n3500-uk9.6.0.2.U6.0.1.CSCab00001.bin
Install operation 2 completed successfully at Thu Jan 9 01:19:45 2018
-----
Install operation 3 by user 'admin' at Thu Jan 9 01:20:05 2018
Install commit n3500-uk9.6.0.2.U6.0.1.CSCab00001.bin
Install operation 3 completed successfully at Thu Jan 9 01:20:08 2018
-----
Install operation 4 by user 'admin' at Thu Jan 9 01:20:21 2018
Install deactivate n3500-uk9.6.0.2.U6.0.1.CSCab00001.bin
Install operation 4 completed successfully at Thu Jan 9 01:20:36 2018
-----
Install operation 5 by user 'admin' at Thu Jan 9 01:20:43 2018
Install commit n3500-uk9.6.0.2.U6.0.1.CSCab00001.bin
Install operation 5 completed successfully at Thu Jan 9 01:20:46 2014
-----
```



```
Install operation 6 by user 'admin' at Thu Jan 9 01:20:55 2018
Install remove n3500-uk9.6.0.2.U6.0.1.CSCab00001.bin
Install operation 6 completed successfully at Thu Jan 9 01:20:57 2018
```



CHAPTER 20

Configuring Rollback

This chapter contains the following sections:

- [Information About Rollbacks, on page 227](#)
- [Guidelines and Limitations for Rollbacks, on page 227](#)
- [Creating a Checkpoint, on page 228](#)
- [Implementing a Rollback, on page 229](#)
- [Verifying the Rollback Configuration, on page 230](#)

Information About Rollbacks

The rollback feature allows you to take a snapshot, or user checkpoint, of the Cisco NX-OS configuration and then reapply that configuration to your switch at any point without having to reload the switch. A rollback allows any authorized administrator to apply this checkpoint configuration without requiring expert knowledge of the features configured in the checkpoint.

You can create a checkpoint copy of the current running configuration at any time. Cisco NX-OS saves this checkpoint as an ASCII file which you can use to roll back the running configuration to the checkpoint configuration at a future time. You can create multiple checkpoints to save different versions of your running configuration.

When you roll back the running configuration, you can trigger an atomic rollback. An atomic rollback implements a rollback only if no errors occur.

Guidelines and Limitations for Rollbacks

A rollback has the following configuration guidelines and limitations:

- You can create up to ten checkpoint copies.
- You cannot apply the checkpoint file of one switch into another switch.
- Your checkpoint file names must be 75 characters or less.
- You cannot start a checkpoint filename with the word system.
- You can start a checkpoint filename with the word auto.
- You can name a checkpoint file summary or any abbreviation of the word summary.

- Only one user can perform a checkpoint, rollback, or copy the running configuration to the startup configuration at the same time.
- After you enter the **write erase** and **reload** command, checkpoints are deleted. You can use the clear checkpoint database command to clear out all checkpoint files.
- When checkpoints are created on bootflash, differences with the running-system configuration cannot be performed before performing the rollback, and the system reports “No Changes.”
- Checkpoints are local to a switch.
- Checkpoints that are created using the **checkpoint** and **checkpoint** *checkpoint_name* commands are present upon a switchover for all switches.
- A rollback to files on bootflash is supported only on files that are created using the **checkpoint** *checkpoint_name* command and not on any other type of ASCII file.
- Checkpoint names must be unique. You cannot overwrite previously saved checkpoints with the same name.
- The Cisco NX-OS commands may differ from the Cisco IOS commands.

Creating a Checkpoint

You can create up to ten checkpoints of your configuration per switch.

SUMMARY STEPS

1. switch# **checkpoint** { [*cp-name*] [**description** *descr*] |**file** *file-name*}
2. (Optional) switch# **no checkpoint***cp-name*
3. (Optional) switch# **show checkpoint***cp-name*

DETAILED STEPS

	Command or Action	Purpose
Step 1	switch# checkpoint { [<i>cp-name</i>] [description <i>descr</i>] file <i>file-name</i> } Example: switch# checkpoint stable	Creates a checkpoint of the running configuration to either a user checkpoint name or a file. The checkpoint name can be any alphanumeric string up to 80 characters but cannot contain spaces. If you do not provide a name, Cisco NX-OS sets the checkpoint name to user-checkpoint- <i><number></i> where number is from 1 to 10. The description can contain up to 80 alphanumeric characters, including spaces.
Step 2	(Optional) switch# no checkpoint <i>cp-name</i> Example: switch# no checkpoint stable	You can use the no form of the checkpoint command to remove a checkpoint name. Use the delete command to remove a checkpoint file.
Step 3	(Optional) switch# show checkpoint <i>cp-name</i> Example:	Displays the contents of the checkpoint name.

	Command or Action	Purpose
	[all] switch# show checkpoint stable	

Implementing a Rollback

You can implement a rollback to a checkpoint name or file. Before you implement a rollback, you can view the differences between source and destination checkpoints that reference current or saved configurations.



Note If you make a configuration change during an atomic rollback, the rollback will fail.

SUMMARY STEPS

1. **show diff rollback-patch** {**checkpoint** *src-cp-name* | **running-config** | **startup-config** | **file** *source-file*} {**checkpoint** *dest-cp-name* | **running-config** | **startup-config** | **file** *dest-file*}
2. **rollback running-config** {**checkpoint** *cp-name* | **file** *cp-file*} **atomic**

DETAILED STEPS

	Command or Action	Purpose
Step 1	show diff rollback-patch { checkpoint <i>src-cp-name</i> running-config startup-config file <i>source-file</i> } { checkpoint <i>dest-cp-name</i> running-config startup-config file <i>dest-file</i> } Example: switch# show diff rollback-patch checkpoint stable running-config	Displays the differences between the source and destination checkpoint selections.
Step 2	rollback running-config { checkpoint <i>cp-name</i> file <i>cp-file</i> } atomic Example: switch# rollback running-config checkpoint stable	Creates an atomic rollback to the specified checkpoint name or file if no errors occur.

Example

The following example shows how to create a checkpoint file and then implement an atomic rollback to a user checkpoint name:

```
switch# checkpoint stable
switch# rollback running-config checkpoint stable atomic
```

Verifying the Rollback Configuration

Use the following commands to verify the rollback configuration:

Command	Purpose
show checkpoint <i>name</i> [all]	Displays the contents of the checkpoint name.
show checkpoint all [user system]	Displays the contents of all checkpoints in the current switch. You can limit the displayed checkpoints to user or system-generated checkpoints.
show checkpoint summary [user system]	Displays a list of all checkpoints in the current switch. You can limit the displayed checkpoints to user or system-generated checkpoints.
show diff rollback-patch { checkpoint <i>src-cp-name</i> running-config startup-config file <i>source-file</i> } { checkpoint <i>dest-cp-name</i> running-config startup-config file <i>dest-file</i> }	Displays the differences between the source and destination checkpoint selections.
show rollback log [exec verify]	Displays the contents of the rollback log.



Note Use the **clear checkpoint database** command to delete all checkpoint files.



CHAPTER 21

Configuring User Accounts and RBAC

This chapter contains the following sections:

- [Information About User Accounts and RBAC, on page 231](#)
- [Guidelines and Limitations for User Accounts, on page 234](#)
- [Configuring User Accounts, on page 235](#)
- [Configuring RBAC, on page 236](#)
- [Verifying the User Accounts and RBAC Configuration, on page 240](#)
- [Configuring User Accounts Default Settings for the User Accounts and RBAC, on page 240](#)

Information About User Accounts and RBAC

Cisco Nexus Series switches use role-based access control (RBAC) to define the amount of access that each user has when the user logs into the switch.

With RBAC, you define one or more user roles and then specify which management operations each user role is allowed to perform. When you create a user account for the switch, you associate that account with a user role, which then determines what the individual user is allowed to do on the switch.

User Roles

User roles contain rules that define the operations allowed for the user who is assigned the role. Each user role can contain multiple rules and each user can have multiple roles. For example, if role1 allows access only to configuration operations, and role2 allows access only to debug operations, users who belong to both role1 and role2 can access configuration and debug operations. You can also limit access to specific VLANs, and interfaces.

The switch provides the following default user roles:

network-admin (superuser)

Complete read and write access to the entire switch.

network-operator

Complete read access to the switch. However, the network-operator role cannot run the **show running-config** and **show startup-config** commands.



Note If you belong to multiple roles, you can execute a combination of all the commands permitted by these roles. Access to a command takes priority over being denied access to a command. For example, suppose a user has RoleA, which denied access to the configuration commands. However, the user also has RoleB, which has access to the configuration commands. In this case, the user has access to the configuration commands.



Note Only network-admin user can perform a Checkpoint or Rollback in the RBAC roles. Though other users have these commands as a permit rule in their role, the user access is denied when you try to execute these commands.

Rules

The rule is the basic element of a role. A rule defines what operations the role allows the user to perform. You can apply rules for the following parameters:

Command

A command or group of commands defined in a regular expression.

Feature

Commands that apply to a function provided by the Cisco Nexus device. Enter the **show role feature** command to display the feature names available for this parameter.

Feature group

Default or user-defined group of features. Enter the **show role feature-group** command to display the default feature groups available for this parameter.

OID

An SNMP object identifier (OID).

These parameters create a hierarchical relationship. The most basic control parameter is the command. The next control parameter is the feature, which represents all commands associated with the feature. The last control parameter is the feature group. The feature group combines related features and allows you to easily manage the rules.

SNMP OID is supported for RBAC. You can configure a read-only or read-and-write rule for an SNMP OID.

You can configure up to 256 rules for each role. The user-specified rule number determines the order in which the rules are applied. Rules are applied in descending order. For example, if a role has three rules, rule 3 is applied before rule 2, which is applied before rule 1.

User Role Policies

You can define user role policies to limit the switch resources that the user can access, or to limit access to interfaces, VLANs, and VSANs.

User role policies are constrained by the rules defined for the role. For example, if you define an interface policy to permit access to specific interfaces, the user does not have access to the interfaces unless you configure a command rule for the role to permit the **interface** command.

If a command rule permits access to specific resources (interfaces, VLANs), the user is permitted to access these resources, even if the user is not listed in the user role policies associated with that user.

User Account Configuration Restrictions

The following words are reserved and cannot be used to configure users:

- adm
- bin
- daemon
- ftp
- ftpuser
- games
- gdm
- gopher
- halt
- lp
- mail
- mailnull
- man
- mtsuser
- news
- nobody
- san-admin
- shutdown
- sync
- sys
- uucp
- xfs

User Password Requirements

Cisco Nexus device passwords are case sensitive and can contain alphanumeric characters.



Note Special characters, such as the dollar sign (\$) or the percent sign (%), can be used in Cisco Nexus device passwords.

If a password is trivial (such as a short, easy-to-decipher password), the Cisco Nexus device rejects the password. Be sure to configure a strong password for each user account. A strong password has the following characteristics:

- At least eight characters long
- Does not contain many consecutive characters (such as "abcd")
- Does not contain many repeating characters (such as "aaabbb")
- Does not contain dictionary words
- Does not contain proper names
- Contains both uppercase and lowercase characters
- Contains numbers

The following are examples of strong passwords:

- If2CoM18
- 2009AsdfLkj30
- Cb1955S21



Note For security reasons, user passwords do not display in the configuration files.

Guidelines and Limitations for User Accounts

User accounts have the following guidelines and limitations when configuring user accounts and RBAC:

- Regardless of the read-write rule configured for a user role, some commands can be executed only through the predefined network-admin role.
- Up to 256 rules can be added to a user role.
- A maximum of 64 user roles can be assigned to a user account.
- You can assign a user role to more than one user account.
- Predefined roles such as network-admin, network-operator, and san-admin are not editable.
- Add, delete, and editing of rules is not supported for the SAN admin user role.
- The interface, VLAN, and/or VSAN scope cannot be changed for the SAN admin user role.



Note A user account must have at least one user role.

Configuring User Accounts



Note Changes to user account attributes do not take effect until the user logs in and creates a new session.

SUMMARY STEPS

1. switch# **configure terminal**
2. (Optional) switch(config)# **show role**
3. switch(config) # **username** *user-id* [**password** *password*] [**expire** *date*] [**role** *role-name*]
4. switch(config) # **exit**
5. (Optional) switch# **show user-account**
6. (Optional) switch# **copy running-config startup-config**

DETAILED STEPS

	Command or Action	Purpose
Step 1	switch# configure terminal	Enters global configuration mode.
Step 2	(Optional) switch(config)# show role	Displays the user roles available. You can configure other user roles, if necessary.
Step 3	switch(config) # username <i>user-id</i> [password <i>password</i>] [expire <i>date</i>] [role <i>role-name</i>]	Configures a user account. The <i>user-id</i> is a case-sensitive, alphanumeric character string with a maximum of 28 characters. The default <i>password</i> is undefined. Note If you do not specify a password, the user might not be able to log into the switch. The expire <i>date</i> option format is YYYY-MM-DD. The default is no expiry date.
Step 4	switch(config) # exit	Exits global configuration mode.
Step 5	(Optional) switch# show user-account	Displays the role configuration.
Step 6	(Optional) switch# copy running-config startup-config	Copies the running configuration to the startup configuration.

Example

The following example shows how to configure a user account:

```

switch# configure terminal
switch(config)# username NewUser password 4Ty18Rnt
switch(config)# exit
switch# show user-account

```

Configuring RBAC

Creating User Roles and Rules

The rule number that you specify determines the order in which the rules are applied. Rules are applied in descending order. For example, if a role has three rules, rule 3 is applied before rule 2, which is applied before rule 1.

SUMMARY STEPS

1. switch# **configure terminal**
2. switch(config) # **role name** *role-name*
3. switch(config-role) # **rule number** {deny | permit} **command** *command-string*
4. switch(config-role)# **rule number** {deny | permit} {read | read-write}
5. switch(config-role)# **rule number** {deny | permit} {read | read-write} **feature** *feature-name*
6. switch(config-role)# **rule number** {deny | permit} {read | read-write} **feature-group** *group-name*
7. (Optional) switch(config-role)# **description** *text*
8. switch(config-role)# **end**
9. (Optional) switch# **show role**
10. (Optional) switch# **copy running-config startup-config**

DETAILED STEPS

	Command or Action	Purpose
Step 1	switch# configure terminal	Enters global configuration mode.
Step 2	switch(config) # role name <i>role-name</i>	Specifies a user role and enters role configuration mode. The <i>role-name</i> argument is a case-sensitive, alphanumeric character string with a maximum of 16 characters.
Step 3	switch(config-role) # rule number {deny permit} command <i>command-string</i>	Configures a command rule. The <i>command-string</i> can contain spaces and regular expressions. For example, interface ethernet * includes all Ethernet interfaces. Repeat this command for as many rules as needed.

	Command or Action	Purpose
Step 4	switch(config-role)# rule <i>number</i> {deny permit} {read read-write}	Configures a read-only or read-and-write rule for all operations.
Step 5	switch(config-role)# rule <i>number</i> {deny permit} {read read-write} feature <i>feature-name</i>	Configures a read-only or read-and-write rule for a feature. Use the show role feature command to display a list of features. Repeat this command for as many rules as needed.
Step 6	switch(config-role)# rule <i>number</i> {deny permit} {read read-write} feature-group <i>group-name</i>	Configures a read-only or read-and-write rule for a feature group. Use the show role feature-group command to display a list of feature groups. Repeat this command for as many rules as needed.
Step 7	(Optional) switch(config-role)# description <i>text</i>	Configures the role description. You can include spaces in the description.
Step 8	switch(config-role)# end	Exits role configuration mode.
Step 9	(Optional) switch# show role	Displays the user role configuration.
Step 10	(Optional) switch# copy running-config startup-config	Saves the change persistently through reboots and restarts by copying the running configuration to the startup configuration.

Example

This example shows how to create user roles and specify rules:

```
switch# configure terminal
switch(config)# role name UserA
switch(config-role)# rule deny command clear users
switch(config-role)# rule deny read-write
switch(config-role)# description This role does not allow users to use clear commands
switch(config-role)# end
switch(config)# show role
```

Creating Feature Groups

SUMMARY STEPS

1. switch# **configure terminal**
2. switch(config) # **role feature-group** *group-name*
3. switch(config) # **exit**
4. (Optional) switch# **show role feature-group**
5. (Optional) switch# **copy running-config startup-config**

DETAILED STEPS

	Command or Action	Purpose
Step 1	switch# configure terminal	Enters global configuration mode.
Step 2	switch(config) # role feature-group <i>group-name</i>	Specifies a user role feature group and enters role feature group configuration mode. The <i>group-name</i> is a case-sensitive, alphanumeric character string with a maximum of 32 characters.
Step 3	switch(config) # exit	Exits global configuration mode.
Step 4	(Optional) switch# show role feature-group	Displays the role feature group configuration.
Step 5	(Optional) switch# copy running-config startup-config	Saves the change persistently through reboots and restarts by copying the running configuration to the startup configuration.

Example

This example shows how to create a feature group:

```
switch# configure terminal
switch(config) # role feature-group group1
switch(config) # exit
switch# show role feature-group
switch# copy running-config startup-config
switch#
```

Changing User Role Interface Policies

You can change a user role interface policy to limit the interfaces that the user can access. Specify a list of interfaces that the role can access. You can specify it for as many interfaces as needed.

SUMMARY STEPS

1. switch# **configure terminal**
2. switch(config) # **role name** *role-name*
3. switch(config-role) # **interface policy deny**
4. switch(config-role-interface) # **permit interface** *interface-list*
5. switch(config-role-interface) # **exit**
6. (Optional) switch(config-role) # **show role**
7. (Optional) switch(config-role) # **copy running-config startup-config**

DETAILED STEPS

	Command or Action	Purpose
Step 1	switch# configure terminal	Enters global configuration mode.

	Command or Action	Purpose
Step 2	switch(config) # role name <i>role-name</i>	Specifies a user role and enters role configuration mode.
Step 3	switch(config-role) # interface policy deny	Enters role interface policy configuration mode.
Step 4	switch(config-role-interface) # permit interface <i>interface-list</i>	Specifies a list of interfaces that the role can access. Repeat this command for as many interfaces as needed. For this command, you can specify Ethernet interfaces.
Step 5	switch(config-role-interface) # exit	Exits role interface policy configuration mode.
Step 6	(Optional) switch(config-role) # show role	Displays the role configuration.
Step 7	(Optional) switch(config-role) # copy running-config startup-config	Copies the running configuration to the startup configuration.

Example

The following example shows how to change a user role interface policy to limit the interfaces that the user can access:

```
switch# configure terminal
switch(config)# role name UserB
switch(config-role)# interface policy deny
switch(config-role-interface)# permit interface ethernet 2/1
switch(config-role-interface)# permit interface fc 3/1
switch(config-role-interface)# permit interface vfc 30/1
```

Changing User Role VLAN Policies

You can change a user role VLAN policy to limit the VLANs that the user can access.

SUMMARY STEPS

1. switch# **configure terminal**
2. switch(config) # **role name** *role-name*
3. switch(config-role) # **vlan policy deny**
4. switch(config-role-vlan) # **permit vlan** *vlan-list*
5. switch(config-role-vlan) # **exit**
6. (Optional) switch# **show role**
7. (Optional) switch# **copy running-config startup-config**

DETAILED STEPS

	Command or Action	Purpose
Step 1	switch# configure terminal	Enters global configuration mode.
Step 2	switch(config) # role name <i>role-name</i>	Specifies a user role and enters role configuration mode.

	Command or Action	Purpose
Step 3	switch(config-role)# vlan policy deny	Enters role VLAN policy configuration mode.
Step 4	switch(config-role-vlan)# permit vlan <i>vlan-list</i>	Specifies a range of VLANs that the role can access. Repeat this command for as many VLANs as needed.
Step 5	switch(config-role-vlan)# exit	Exits role VLAN policy configuration mode.
Step 6	(Optional) switch# show role	Displays the role configuration.
Step 7	(Optional) switch# copy running-config startup-config	Saves the change persistently through reboots and restarts by copying the running configuration to the startup configuration.

Verifying the User Accounts and RBAC Configuration

Use one of the following commands to verify the configuration:

Command	Purpose
show role [<i>role-name</i>]	Displays the user role configuration
show role feature	Displays the feature list.
show role feature-group	Displays the feature group configuration.
show startup-config security	Displays the user account configuration in the startup configuration.
show running-config security [all]	Displays the user account configuration in the running configuration. The all keyword displays the default values for the user accounts.
show user-account	Displays user account information.

Configuring User Accounts Default Settings for the User Accounts and RBAC

The following table lists the default settings for user accounts and RBAC parameters.

Table 31: Default User Accounts and RBAC Parameters

Parameters	Default
User account password	Undefined.
User account expiry date	None.
Interface policy	All interfaces are accessible.

Parameters	Default
VLAN policy	All VLANs are accessible.
VFC policy	All VFCs are accessible.
VETH policy	All VETHs are accessible.



INDEX

A

- access restriction, configuring **29**
 - ntp **29**
- action statements **129**
 - EEM **129**
- action statements, configuring **136**
 - EEM **136**
- activating sessions **168**
 - SPAN **168**
- Active Buffer Monitoring **209–210**
 - configuring **210**
 - overview **209**
- adding show commands, alert groups **72**
 - smart call home **72**
- alert groups **59**
 - smart call home **59**
- associating alert groups **71**
 - smart call home **71**

B

- buffer histogram data **210–211**
 - accessing **210**
 - buffer histogram data **210**
 - collecting **210**
 - displaying **211**
- buffer monitoring **210**
 - configuring **210**

C

- call home notifications **78–79**
 - full-text format for syslog **78**
 - XML format for syslog **79**
- changed information **1**
 - description **1**
- clock manager **24**
 - ntp **24**
- committing changes **33**
 - ntp configuration **33**
- configuration example **199–200**
 - ERSPAN **199–200**
 - destination **200**
 - source **199**

- configuration examples **35**
 - ntp **35**
- configuration, verifying **96**
 - scheduler **96**
- contact information, configuring **67**
 - smart call home **67**
- creating, deleting sessions **164**
 - SPAN **164**

D

- default ntp settings **25**
- default parameters **185**
 - ERSPAN **185**
- default settings **65, 86, 88, 131**
 - EEM **131**
 - rollback **86**
 - scheduler **88**
 - smart call home **65**
- default SNMP settings **103**
- defining EEM policies **138**
 - VSH script **138**
- description, configuring **167**
 - SPAN **167**
- destination ports, characteristics **161**
 - SPAN **161**
- destination profile, creating **69**
 - smart call home **69**
- destination profile, modifying **70**
 - smart call home **70**
- destination profiles **58**
 - smart call home **58**
- destinations **160**
 - SPAN **160**
- device IDs **61**
 - call home format **61**
- diagnostics **123–124, 126**
 - configuring **124**
 - default settings **126**
 - expansion modules **124**
 - health monitoring **124**
 - runtime **123**
- disabling **53, 95**
 - DOM logging **53**
 - scheduler **95**

displaying information [172](#)
 SPAN [172](#)
 displaying installation log information [224](#)
 duplicate message throttling, disabling [75–76](#)
 smart call home [75–76](#)

E

e-mail details, configuring [73](#)
 smart call home [73](#)
 e-mail notifications [57](#)
 smart call home [57](#)
 EEM [128–132](#), [134](#), [136](#), [139–141](#)
 action statements [129](#)
 action statements, configuring [136](#)
 default settings [131](#)
 defining environment variables [131](#)
 event statements [128](#)
 event statements, configuring [134](#)
 policies [128](#)
 prerequisites [130](#)
 syslog script [141](#)
 system policies, overriding [140](#)
 user policy, defining [132](#)
 VSH script [139](#)
 registering and activating [139](#)
 VSH script policies [130](#)
 embedded event manager [127](#)
 overview [127](#)
 enabling [52](#), [89](#)
 DOM logging [52](#)
 scheduler [89](#)
 environment variables, defining [131](#)
 EEM [131](#)
 ERSPAN [181–183](#), [185–186](#), [189](#), [199–200](#)
 configuring destination sessions [189](#)
 configuring source sessions [186](#)
 default parameters [185](#)
 destination [200](#)
 configuration example [200](#)
 destination sessions [189](#)
 configuring for ERSPAN [189](#)
 destinations [182](#)
 high availability [183](#)
 information about [181](#)
 prerequisites [183](#)
 related documents [200](#)
 sessions [183](#)
 multiple [183](#)
 source [199](#)
 configuration example [199](#)
 source sessions [186](#)
 configuring for ERSPAN [186](#)
 sources [181](#)
 types [181](#)

Ethernet destination port, configuring [164](#)
 SPAN [164](#)
 event statements [128](#)
 EEM [128](#)
 event statements, configuring [134](#)
 EEM [134](#)
 example [96–97](#)
 job schedule, displaying [97](#)
 scheduler job, creating [96](#)
 scheduler job, scheduling [96](#)
 scheduler jobs, displaying results [97](#)
 executing a session [85](#)

F

facility messages logging [45](#)
 configuring [45](#)
 feature groups, creating [237](#)
 RBAC [237](#)
 feature history [37](#)
 ntp [37](#)
 filtering SNMP requests [106](#)

G

GOLD diagnostics [123–124](#)
 configuring [124](#)
 expansion modules [124](#)
 health monitoring [124](#)
 runtime [123](#)
 guidelines [24](#)
 ntp [24](#)
 guidelines and limitations [40](#), [65](#), [88](#), [103](#), [234](#)
 scheduler [88](#)
 smart call home [65](#)
 SNMP [103](#)
 system message logging [40](#)
 user accounts [234](#)
 guidelines and limitations for configuration rollback [227](#)

H

health monitoring diagnostics [124](#)
 information [124](#)
 high availability [9](#)
 PTP [9](#)
 high availability [9](#)

I

IDs [61](#)
 serial IDs [61](#)
 information [23](#)
 ntp [23](#)

- information about [87](#)
 - scheduler [87](#)
- interfaces, configuring [13](#)
 - PTP [13](#)

J

- job schedule, displaying [97](#)
 - example [97](#)
- job, deleting [92](#)
 - scheduler [92](#)

L

- linkDown notifications [112–113](#)
- linkUp notifications [112–113](#)
- log file size, defining [89](#)
 - scheduler [89](#)
- log file, clearing [95](#)
 - scheduler [95](#)
- log files [88](#)
 - scheduler [88](#)
- logging [45](#)
 - facility messages [45](#)
 - module messages [45](#)

M

- message encryption [105](#)
 - SNMP [105](#)
- module messages logging [45](#)
 - configuring [45](#)

N

- new information [1](#)
 - description [1](#)
- notification receivers [106](#)
 - SNMP [106](#)
- ntp [23–25, 29, 35, 37](#)
 - access restriction, configuring [29](#)
 - clock manager [24](#)
 - configuration examples [35](#)
 - default settings [25](#)
 - feature history [37](#)
 - guidelines [24](#)
 - information [23](#)
 - related documents [37](#)
 - time server [24](#)
 - using cfs [24](#)
 - virtualization [24](#)
- ntp configuration [33](#)
 - committing changes [33](#)
- ntp using cfs [24](#)

O

- overview [127](#)
 - embedded event manager [127](#)

P

- password requirements [233](#)
- periodic inventory notifications, configuring [74](#)
 - smart call home [74](#)
- policies [128](#)
 - EEM [128](#)
- prerequisites [130, 183](#)
 - EEM [130](#)
 - ERSPAN [183](#)
- PTP [7–9, 11, 13](#)
 - configuring globally [11](#)
 - default settings [11](#)
 - device types [8](#)
 - interface, configuring [13](#)
 - overview [7](#)
 - process [9](#)

R

- RBAC [231–233, 235–240](#)
 - feature groups, creating [237](#)
 - rules [232](#)
 - user account restrictions [233](#)
 - user accounts, configuring [235](#)
 - user role interface policies, changing [238](#)
 - user role VLAN policies, changing [239](#)
 - user roles [231](#)
 - user roles and rules, configuring [236](#)
 - verifying [240](#)
- registering [66](#)
 - smart call home [66](#)
- related documents [37, 200](#)
 - ERSPAN [200](#)
 - ntp [37](#)
- remote user authentication [88](#)
 - scheduler [88](#)
- remote user authentication, configuring [90–91](#)
 - scheduler [90–91](#)
- requirements [233](#)
 - user passwords [233](#)
- roles [231](#)
 - authentication [231](#)
- rollback [83, 86](#)
 - checkpoint copy [83](#)
 - creating a checkpoint copy [83](#)
 - default settings [86](#)
 - deleting a checkpoint file [83](#)
 - description [83](#)
 - example configuration [83](#)

- rollback (*continued*)
 - guidelines [83](#)
 - high availability [83](#)
 - implementing a rollback [83](#)
 - limitations [83](#)
 - reverting to checkpoint file [83](#)
 - verifying configuration [86](#)
 - rules [232](#)
 - RBAC [232](#)
 - runtime diagnostics [123](#)
 - information [123](#)
- S**
- scheduler [87–93, 95–97](#)
 - configuration, verifying [96](#)
 - default settings [88](#)
 - disabling [95](#)
 - enabling [89](#)
 - guidelines and limitations [88](#)
 - information about [87](#)
 - job, deleting [92](#)
 - log file size, defining [89](#)
 - log file, clearing [95](#)
 - log files [88](#)
 - remote user authentication [88](#)
 - remote user authentication, configuring [90–91](#)
 - standards [97](#)
 - timetable, defining [93](#)
 - scheduler job, creating [96](#)
 - example [96](#)
 - scheduler job, scheduling [96](#)
 - example [96](#)
 - scheduler jobs, displaying results [97](#)
 - example [97](#)
 - serial IDs [61](#)
 - description [61](#)
 - server IDs [61](#)
 - description [61](#)
 - session manager [83, 85–86](#)
 - committing a session [85](#)
 - configuring an ACL session (example) [85](#)
 - description [83](#)
 - discarding a session [85](#)
 - guidelines [83](#)
 - limitations [83](#)
 - saving a session [85](#)
 - verifying configuration [86](#)
 - verifying the session [85](#)
 - smart call home [57–59, 65–67, 69–78](#)
 - adding show commands, alert groups [72](#)
 - alert groups [59](#)
 - associating alert groups [71](#)
 - contact information, configuring [67](#)
 - default settings [65](#)
 - description [57](#)
 - smart call home (*continued*)
 - destination profile, creating [69](#)
 - destination profile, modifying [70](#)
 - destination profiles [58](#)
 - duplicate message throttling, disabling [75–76](#)
 - e-mail details, configuring [73](#)
 - guidelines and limitations [65](#)
 - message format options [58](#)
 - periodic inventory notifications [74](#)
 - prerequisites [65](#)
 - registering [66](#)
 - testing the configuration [77](#)
 - verifying [78](#)
 - smart call home messages [58, 60](#)
 - configuring levels [60](#)
 - format options [58](#)
 - SMUs [217–219, 221–224](#)
 - activating packages [221](#)
 - adding packages [221](#)
 - committing the active package set [222](#)
 - deactivating packages [223](#)
 - described [217](#)
 - guidelines [219](#)
 - limitations [219](#)
 - package management [218](#)
 - preparing for package installation [219](#)
 - prerequisites [218](#)
 - removing packages [223](#)
 - SNMP [99–106, 109, 115](#)
 - access groups [103](#)
 - configuring users [104](#)
 - default settings [103](#)
 - disabling [115](#)
 - filtering requests [106](#)
 - functional overview [99](#)
 - group-based access [103](#)
 - guidelines and limitations [103](#)
 - inband access [109](#)
 - message encryption [105](#)
 - notification receivers [106](#)
 - security model [101](#)
 - trap notifications [100](#)
 - user synchronization with CLI [102](#)
 - user-based security [101](#)
 - SNMP [101](#)
 - version 3 security features [100](#)
 - SNMP (Simple Network Management Protocol) [100](#)
 - versions [100](#)
 - SNMP notification receivers [107](#)
 - configuring with VRFs [107](#)
 - SNMP notifications [108](#)
 - filtering based on a VRF [108](#)
 - snmp-server name [104](#)
 - SNMPv3 [100, 105](#)
 - assigning multiple roles [105](#)
 - security features [100](#)

- source IDs [61](#)
 - call home event format [61](#)
- source ports, characteristics [160](#)
 - SPAN [160](#)
- source ports, configuring [165](#)
 - SPAN [165](#)
- SPAN [159–161, 164–168, 172](#)
 - activating sessions [168](#)
 - characteristics, source ports [160](#)
 - creating, deleting sessions [164](#)
 - description, configuring [167](#)
 - destination ports, characteristics [161](#)
 - destinations [160](#)
 - displaying information [172](#)
 - egress sources [160](#)
 - Ethernet destination port, configuring [164](#)
 - ingress sources [160](#)
 - source port channels, configuring [166](#)
 - source ports, configuring [165](#)
 - sources for monitoring [159](#)
 - VLANs, configuring [166](#)
- SPAN sources [160](#)
 - egress [160](#)
 - ingress [160](#)
- standards [97](#)
 - scheduler [97](#)
- Switched Port Analyzer [159](#)
- syslog [47, 141](#)
 - configuring [47](#)
 - EEM [141](#)
- system message logging [39–40](#)
 - guidelines and limitations [40](#)
 - information about [39](#)
- system message logging settings [40](#)
 - defaults [40](#)
- system policies, overriding [140](#)
 - EEM [140](#)

T

- testing the configuration [77](#)
 - smart call home [77](#)
- time server [24](#)
 - ntp [24](#)
- timetable, defining [93](#)
 - scheduler [93](#)
- trap notifications [100](#)

U

- user account restrictions [233](#)
 - RBAC [233](#)
- user accounts [233–234, 240](#)
 - guidelines and limitations [234](#)
 - passwords [233](#)
 - verifying [240](#)
- user policies, defining [132](#)
 - EEM [132](#)
- user role interface policies, changing [238](#)
 - RBAC [238](#)
- user role VLAN policies, changing [239](#)
 - RBAC [239](#)
- user roles [231](#)
 - RBAC [231](#)
- user roles and rules, creating [236](#)
 - RBAC [236](#)
- users [231](#)
 - description [231](#)

V

- verifying [53, 78, 240](#)
 - DOM logging configuration [53](#)
 - RBAC [240](#)
 - smart call home [78](#)
 - user accounts [240](#)
- virtualization [24](#)
 - ntp [24](#)
- VRFs [107–108](#)
 - configuring SNMP notification receivers with [107](#)
 - filtering SNMP notifications [108](#)
- VSH script [138](#)
 - defining EEM policies [138](#)
- VSH script policies [130, 139](#)
 - EEM [130](#)
 - registering and activating [139](#)

W

- warp mode [205–206](#)
 - disabling [206](#)
 - enabling [206](#)
 - overview [205](#)
 - verifying the status of [206](#)

