



Installing the Switch Chassis

- [Safety](#), on page 1
- [Installation Options with Rack-Mount Kits, Racks, and Cabinets](#), on page 2
- [Airflow Considerations](#), on page 2
- [Installation Guidelines](#), on page 3
- [Unpacking and Inspecting the Switch](#), on page 4
- [Installing the Switch Using the NXK-ACC-KIT-1RU Rack-Mount Kit](#), on page 5
- [Installing the Switch Using the N3K-C3064-ACC-KIT Rack-Mount Kit](#), on page 9
- [Grounding the Chassis](#), on page 13
- [Starting the Switch](#), on page 15

Safety

Before you install, operate, or service the switch, see the *Regulatory, Compliance, and Safety Information for the Cisco Nexus 3000 and 9000 Series* for important Safety Information.



Warning

Statement 1071—Warning Definition

IMPORTANT SAFETY INSTRUCTIONS

This warning symbol means danger. You are in a situation that could cause bodily injury. Before you work on any equipment, be aware of the hazards involved with electrical circuitry and be familiar with standard practices for preventing accidents. Use the statement number provided at the end of each warning to locate its translation in the translated safety warnings that accompanied this device.

SAVE THESE INSTRUCTIONS





Warning **Statement 1017**—Restricted Area

This unit is intended for installation in restricted access areas. A restricted access area can be accessed by skilled, instructed or qualified personnel.



Warning **Statement 1030**—Equipment Installation

Only trained and qualified personnel should be allowed to install, replace, or service this equipment.

Installation Options with Rack-Mount Kits, Racks, and Cabinets

The rack-mount kit enables you to install the switch into racks of varying depths. You can position the switch with easy access to either the port connections or the fan and power supply modules.

You can install the switch using the following rack-mount options:

- Rack-mount kit (NXK-ACC-KIT-1RU) which you can order from Cisco. This option offers you easy installation, greater stability, increased weight capacity, added accessibility, and improved removability with front and rear removal.
- Rack-mount kit (N3K-C3064-ACC-KIT) which you can order from Cisco.

You can install the switch in the following types of racks:

- Open EIA rack
- Perforated EIA cabinet

The rack or cabinet that you use must meet the requirements listed the in [General Requirements for Cabinets and Racks](#) section.



Note You are responsible for verifying that your rack and rack-mount hardware comply with the guidelines that are described in this doc.

Airflow Considerations

The switch comes with fan and power supply modules that have either port-side intake or port-side exhaust airflow for cooling the switch. If you are positioning the port end of the switch in a cold aisle, make sure that the switch has port-side intake fan modules with burgundy coloring. If you are positioning the fan and power supply modules in a cold aisle, make sure that the switch has port-side exhaust fan modules with blue colorings. All fan modules must have the same direction of airflow.

Installation Guidelines

When installing the switch, follow these guidelines:

- Ensure that there is adequate clearance space around the switch to allow for servicing the switch and for adequate airflow.
- Ensure that you are positioning the switch in a rack so that it takes in cold air from the cold aisle and exhausts air to the hot aisle. If there is blue coloring on the fan modules, the switch is configured for port-side exhaust airflow and you must position the module side of the switch in a cold aisle. If there is burgundy coloring on the fan modules, the switch is configured for port-side intake airflow and you must position the port side of the switch in a cold aisle.
- Ensure that the chassis can be adequately grounded. If the switch is not mounted in a grounded rack, we recommend connecting the system ground on the chassis directly to an earth ground.
- Ensure that the site power meets the power requirements for the switch. If available, you can use an uninterruptible power supply (UPS) to protect against power failures.



Caution Avoid UPS types that use ferroresonant technology. These UPS types can become unstable with the switch, which can have substantial current draw fluctuations because of fluctuating data traffic patterns.

- Ensure that circuits are sized according to local and national codes. Typically, this often requires one or both of the following:
 - AC power supplies typically require at least a 15-A or 20-A AC circuit, 100 to 240 VAC, and a frequency of 50 to 60 Hz.
 - HVAC/HVDC power supplies require the following:
 - HVAC input voltage range of 230 to 277 VAC with a frequency of 50 to 60 Hz
 - HVDC input voltage range of -240 to -380 VDC
 - DC power supplies require the following:
 - DC input voltage range of -48 to -60 VDC nominal (self-ranging, -40 to -60 VDC)
 - DC line input current (steady state) of 23 A peak at -48 VDC



Caution To prevent loss of input power, ensure the total maximum loads on the circuits supplying power to the switch are within the current ratings for the wiring and breakers.



Note For AC input application, please refer to the statement below:



Warning **Statement 1005**—Circuit Breaker

This product relies on the building's installation for short-circuit (overcurrent) protection. Ensure that the protective devices is rated not greater than 20A (North America), 16A (Europe), and 13A (UK).



Note For DC input application, please refer to the statement below:



Warning **Statement 1005**—Circuit Breaker

This product relies on the building's installation for short-circuit (overcurrent) protection. Ensure that the protective devices is rated not greater than 40A for the regular DC power supplies (rated 48-60VDC) and 10A for the HVDC power supplies.

Unpacking and Inspecting the Switch

Before you install the switch, be sure to unpack and inspect the switch for damage or missing components. If anything is missing or damaged, contact your customer service representative immediately.



Tip Keep the shipping container in case the chassis requires shipping at a later time.

Before you begin

Before you unpack the switch and before you handle any switch components, be sure that you are wearing a grounded electrostatic discharge (ESD) strap. To ground the strap, attach it directly to an earth ground or to a grounded rack or grounded chassis (there must be a metal-to-metal connection to the earth ground).

Step 1 Compare the shipment to the equipment list provided by your customer service representative and verify that you have received all items, including the following:

- Accessory Kit

Step 2 Check for damage and report any discrepancies or damage to your customer service representative. Have the following information ready:

- Invoice number of shipper (see packing slip)
- Model and serial number of the damaged unit
- Description of damage

- Effect of damage on the installation

Step 3 Check to be sure that each of the power supply and the fan tray modules have the expected direction of airflow as follows:

- Port-side intake airflow modules
 - Burgundy (fan modules and AC power supplies)
 - Green (DC power supplies)
- Port-side exhaust airflow modules
 - Blue (fan modules and AC power supplies)
 - Gray (DC power supplies)
- Dual-direction airflow power-supply modules
 - White (see the color of the fan modules to determine the airflow direction used)

Note All power supplies and fan modules must have the same direction of airflow.

Installing the Switch Using the NXK-ACC-KIT-1RU Rack-Mount Kit

To install the switch, you must attach front and rear mounting brackets to the switch, install slider rails on the rear of the rack, slide the switch onto the slider rails, and secure the switch to the front of the rack. Typically, the front of the rack is the side easiest to access for maintenance.



Note You must supply the eight 10-32 or 12-24 screws required to mount the slider rails and switch to the rack.

Before you begin

- You have inspected the switch shipment to ensure that you have everything ordered.
- Make sure that the switch rack-mount kit includes the following parts:
 - Front rack-mount brackets (2)
 - Rear rack-mount brackets (2)
 - Slider rails (2)
 - M4 x 0.7 x 8-mm Phillips countersink screws (12)
- The rack is installed and secured to its location.

Step 1

Install two front rack-mount brackets and the two rear rack-mount brackets to the switch as follows:

a) Determine which end of the chassis is to be located in the cold aisle as follows:

- If the switch has port-side intake modules (fan modules with burgundy coloring), position the switch so that its ports will be in the cold aisle.
- If the switch has port-side exhaust modules (fan modules with blue coloring), position the switch so that its fan and power supply modules will be in the cold aisle.

Note If the power supply modules have white coloring, look at the fan modules to determine the airflow direction for the switch.

b) Position the front rack-mount bracket and the rear rack-mount bracket so that its screw holes are aligned to the screw holes on the side of the chassis.

Note You can align the holes in the rack-mount bracket to the holes on the side of the chassis (see the two ways to mount these brackets on a typical chassis, in following figure). The holes that you use depend on the requirements of your rack and the amount of clearance required for interface cables (3 inches [7.6 mm] minimum) and module handles (1 inch [2.5 mm] minimum).

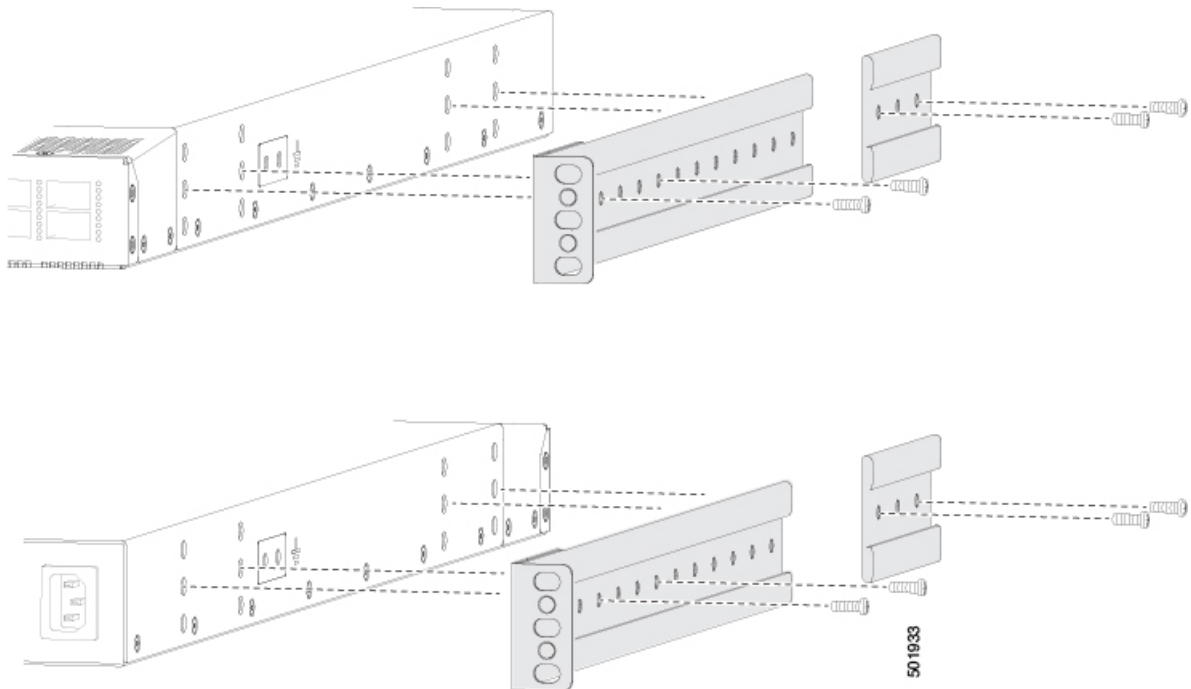

- c) Secure the front-mount bracket and the back-mount bracket to the chassis using four M4 screws and tighten each screw to 12 in-lb (1.36 N·m) of torque.
- d) Repeat Step 1 for the other front rack-mount bracket and the other back-mount bracket on the other side of the switch and be sure to position that bracket the same distance from the front of the switch.

Note Depending on the chassis depth, the back rack-mount bracket may not fit. In that case the back rack-mount bracket is not needed.

Step 2 If you are not installing the chassis into a grounded rack, you must attach a customer-supplied grounding wire to the chassis as explained in the [Grounding the Chassis, on page 13](#) section. If you are installing the chassis into a grounded rack, you can skip this step.

Step 3 Install the slider rails on the rack or cabinet as follows:

- a) Determine which two posts of the rack or cabinet you should use for the slider rails. Of the four vertical posts in the rack or cabinet, two will be used for the front mount brackets attached to the easiest accessed end of the chassis, and the other two posts will have the slider rails.
- b) Position a slider rail at the desired level on the back side of the rack and use 12-24 screws or 10-32 screws, depending on the rack thread type, to attach the rails to the rack (see the following figure). Tighten 12-24 screws to 30 in-lb (3.39 N·m) of torque and tighten 10-32 screws to 20 in-lb (2.26 N·m) of torque.

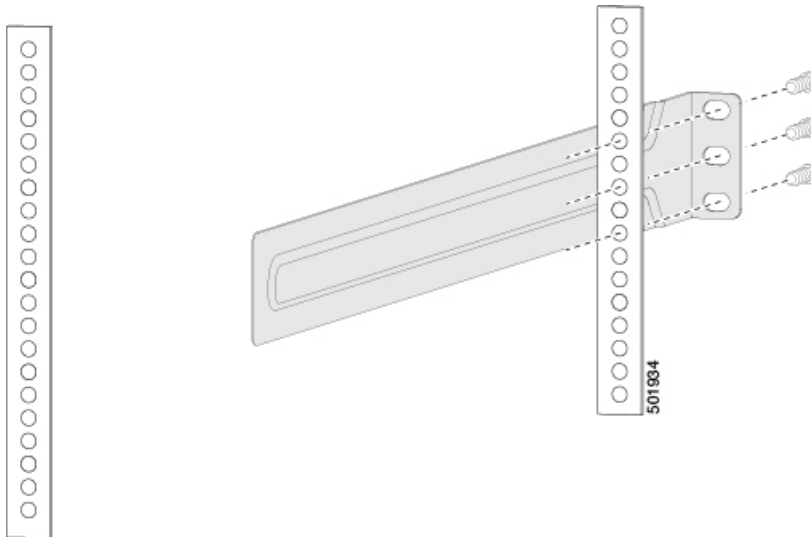

- c) Repeat Step 3 to attach the other slider rail to the other side of the rack.

To make sure that the slider rails are at the same level, you should use a level tool, tape measure, or carefully count the screw holes in the vertical mounting rails.

Step 4 Insert the switch into the rack and attach it as follows:

- a) Holding the switch with both hands, position the two rear rack-mount brackets on the switch between the rack or cabinet posts that do not have slider rails attached to them (see the following figure).

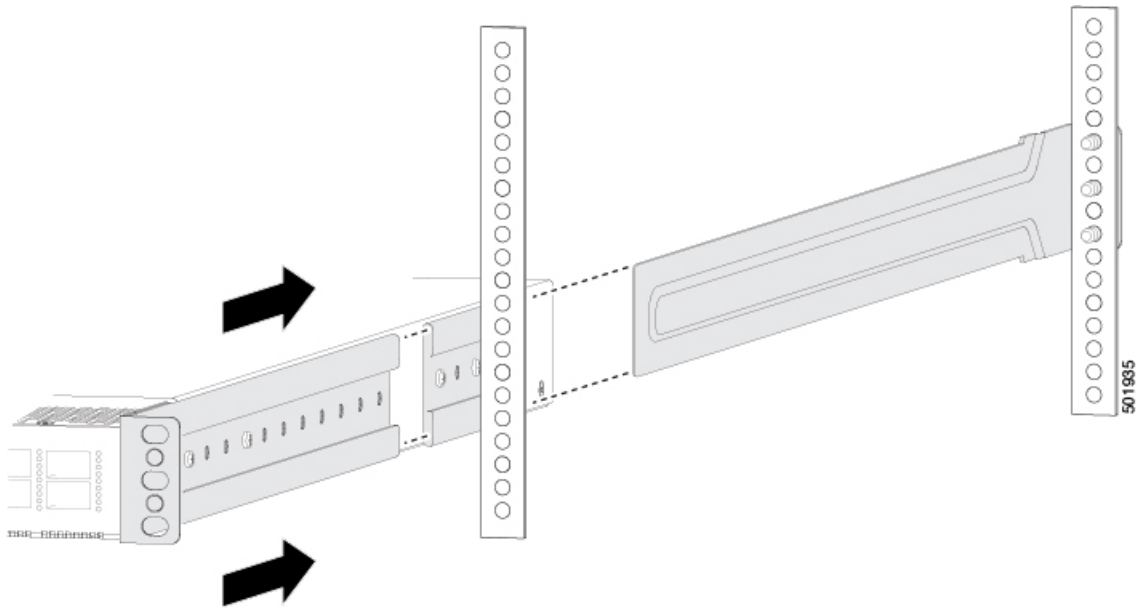

- b) Align the two rear rack-mount guides on either side of the switch with the slider rails installed in the rack. Slide the rack-mount guides onto the slider rails, and then gently slide the switch all the way into the rack until the front rack-mount brackets come in contact with two rack or cabinet posts.
- c) Holding the chassis level, insert screws (12-24 or 10-32, depending on the rack type) in each of the two front rack-mount brackets (using a total of six screws) and into the cage nuts or threaded holes in the vertical rack-mounting rails (see the following figure).

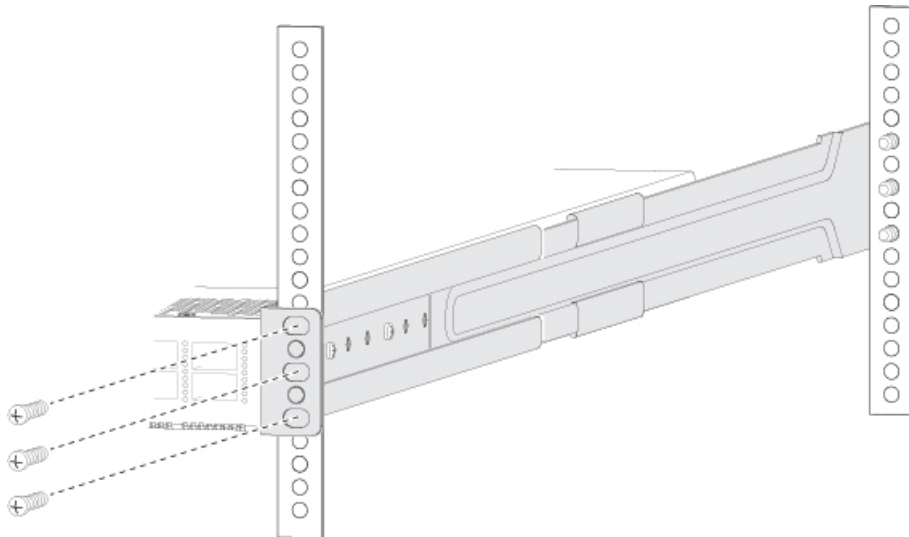

- d) Tighten the 10-32 screws to 20 in-lb (2.26 N·m) or tighten the 12-24 screws to 30 in-lb (3.39 N·m).

Step 5

If you attached a grounding wire to the chassis grounding pad, connect the other end of the wire to the facility ground.

Installing the Switch Using the N3K-C3064-ACC-KIT Rack-Mount Kit

To install the switch, you must attach front and rear mounting brackets to the switch, install slider rails on the rear of the rack, slide the switch onto the slider rails, and secure the switch to the front of the rack. Typically, the front of the rack is the side easiest to access for maintenance.



Note You must supply the eight 10-32 or 12-24 screws required to mount the slider rails and switch to the rack.

Before you begin

- You have inspected the switch shipment to ensure that you have everything ordered.
- Make sure that the switch rack-mount kit includes the following parts:
 - Front rack-mount brackets (2)
 - Rear rack-mount brackets (2)
 - Slider rails (2)
 - M4 x 0.7 x 8-mm Phillips countersink screws (12)
- The rack is installed and secured to its location.

Step 1

Install two front-mount brackets to the switch as follows:

a) Determine which end of the chassis is to be located in the cold aisle as follows:

- If the switch has port-side intake modules (fan modules with burgundy coloring), position the switch so that its ports will be in the cold aisle.
- If the switch has port-side exhaust modules (fan modules with blue coloring), position the switch so that its fan and power supply modules will be in the cold aisle.

Note If the power supply modules have white coloring, look at the fan modules to determine the airflow direction for the switch.

b) Position a front-mount bracket so that four of its screw holes are aligned to the screw holes on the side of the chassis.

Note You can align any four of the holes in the front rack-mount bracket to four of the six screw holes on the side of the chassis (see the two ways to mount these brackets on a typical chassis, in following figure). The holes that you use depend on the requirements of your rack and the amount of clearance required for interface cables (3 inches [7.6 mm] minimum) and module handles (1 inch [2.5 mm] minimum).

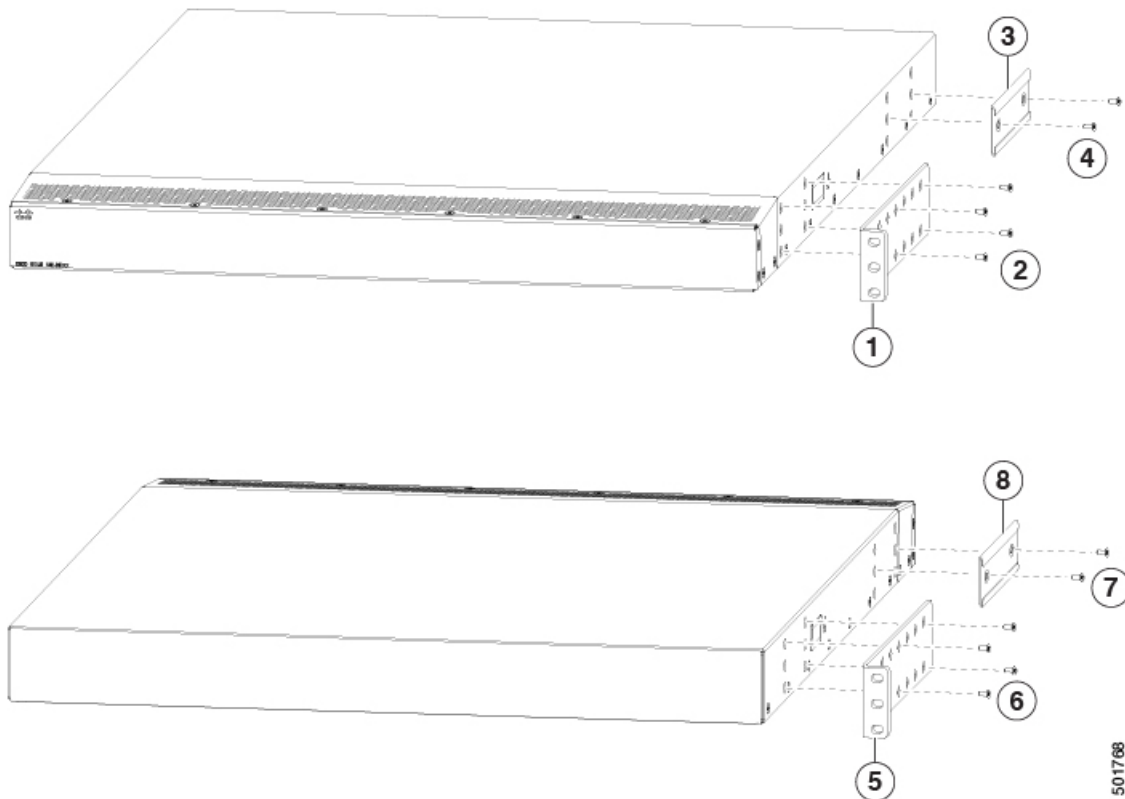

1	Front rack-mount bracket aligned to the port end of the chassis	5	Front rack-mount bracket aligned to the module end of the chassis
2	Four M4 screws used to attach the bracket to the chassis	6	Four M4 screws used to attach the bracket to the chassis
3	Rear rack-mount guide aligned to the module end of the chassis	7	Two M4 screws used to attach the bracket to the chassis
4	Two M4 screws used to attach the bracket to the chassis	8	Rear rack-mount guide aligned to the port end of the chassis

- c) Secure the front-mount bracket to the chassis using four M4 screws and tighten each screw to 12 in-lb (1.36 N·m) of torque.
- d) Repeat Step 1 for the other front rack-mount bracket on the other side of the switch and be sure to position that bracket the same distance from the front of the switch.

Step 2 Install the two rear rack-mount brackets on the chassis as follows:

- a) Align the two screw holes on a rear rack-mount bracket to the middle two screw holes in the remaining six screw holes on a side of the chassis. If you are aligning the guide to holes that are near the port connections end of the chassis, see Callout 3 in the previous figure. Otherwise, see Callout 7 in the previous figure.
- b) Attach the guide to the chassis using two M4 screws (see Callout 4 or 8 in the previous figure). Tighten the screws to 12 in-lb (1.36 N·m) of torque.
- c) Repeat Step 2 for the other rear rack-mount bracket on the other side of the switch.

Step 3 If you are not installing the chassis into a grounded rack, you must attach a customer-supplied grounding wire to the chassis as explained in the [Grounding the Chassis, on page 13](#) section. If you are installing the chassis into a grounded rack, you can skip this step.

Step 4 Install the slider rails on the rack or cabinet as follows:

- a) Determine which two posts of the rack or cabinet you should use for the slider rails. Of the four vertical posts in the rack or cabinet, two will be used for the front mount brackets attached to the easiest accessed end of the chassis, and the other two posts will have the slider rails.
- b) Position a slider rail at the desired level on the back side of the rack and use two 12-24 screws or two 10-32 screws, depending on the rack thread type, to attach the rails to the rack (see the following figure). Tighten 12-24 screws to 30 in-lb (3.39 N·m) of torque and tighten 10-32 screws to 20 in-lb (2.26 N·m) of torque.

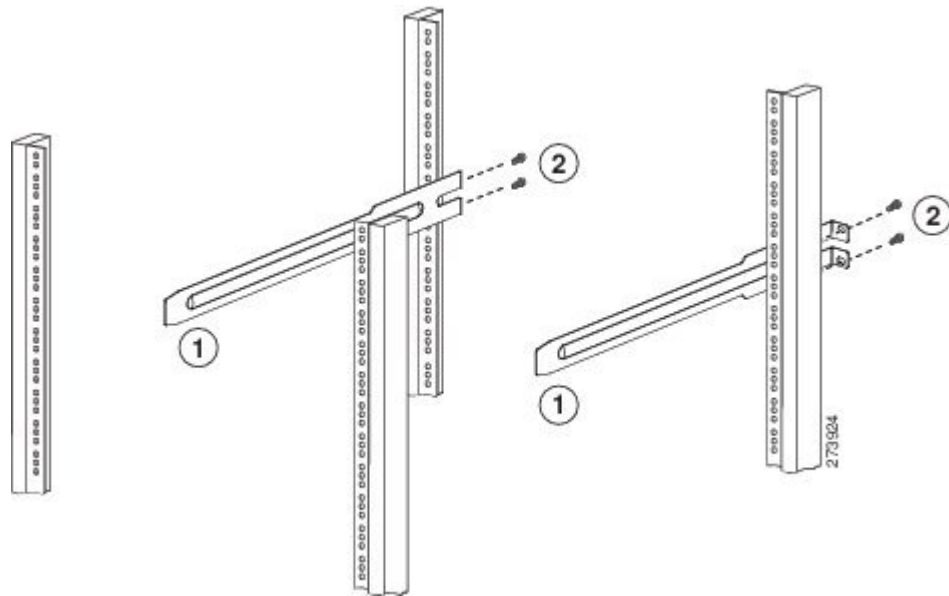

1	Slider rail with screw holes aligned to screw holes in rack	2	Two customer-supplied 12-24 or 10-32 screws used to attach each slider rail to the rack
---	---	---	---

- c) Repeat Step 3 to attach the other slider rail to the other side of the rack.

To make sure that the slider rails are at the same level, you should use a level tool, tape measure, or carefully count the screw holes in the vertical mounting rails.

Step 5 Insert the switch into the rack and attach it as follows:

- a) Holding the switch with both hands, position the two rear rack-mount brackets on the switch between the rack or cabinet posts that do not have slider rails attached to them (see the following figure).

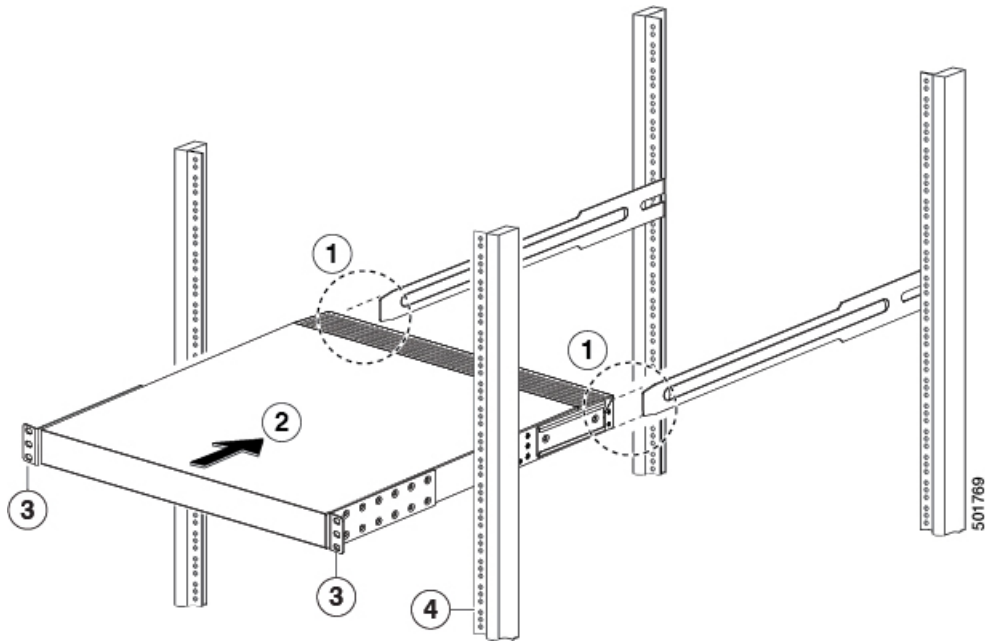

1	Align the two rear rack-mount bracket guides with the slider rails installed in the rack.	3	Front-mount brackets.
2	Slide the rack-mount guides onto the slider rails until the front rack-mount brackets come in contact with the front rack-mount rails.	4	Mounting rails on rack or cabinet posts.

- b) Align the two rear rack-mount guides on either side of the switch with the slider rails installed in the rack. Slide the rack-mount guides onto the slider rails, and then gently slide the switch all the way into the rack until the front rack-mount brackets come in contact with two rack or cabinet posts.
- c) Holding the chassis level, insert two screws (12-24 or 10-32, depending on the rack type) in each of the two front rack-mount brackets (using a total of four screws) and into the cage nuts or threaded holes in the vertical rack-mounting rails (see the following figure).

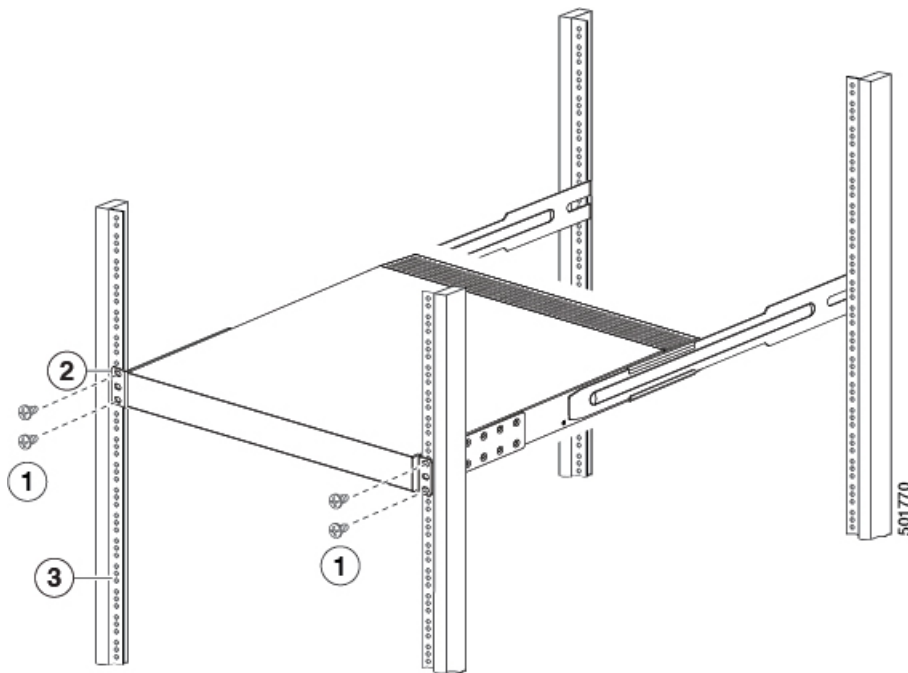

1	Fasten the chassis to the front of the rack with two 12-24 or 10-32 screws on each side.	3	Mounting rails on rack or cabinet posts.
2	Front-mount bracket.		

d) Tighten the 10-32 screws to 20 in-lb (2.26 N·m) or tighten the 12-24 screws to 30 in-lb (3.39 N·m).

Step 6 If you attached a grounding wire to the chassis grounding pad, connect the other end of the wire to the facility ground.

Grounding the Chassis

The switch chassis is automatically grounded when you properly install the switch in a grounded rack with metal-to-metal connections between the switch and rack.

You can also ground the chassis, which is required if the rack is not grounded, by attaching a customer-supplied grounding cable. Attach the cable to the chassis grounding pad and the facility ground.



Warning Statement 1024—Ground Conductor

This equipment must be grounded. To reduce the risk of electric shock, never defeat the ground conductor or operate the equipment in the absence of a suitably installed ground conductor. Contact the appropriate electrical inspection authority or an electrician if you are uncertain that suitable grounding is available.



Warning Statement 1046—Installing or Replacing the Unit

To reduce risk of electric shock, when installing or replacing the unit, the ground connection must always be made first and disconnected last.

Before you begin

Before you can ground the chassis, you must have a connection to the earth ground for the data center building.

- Step 1** Use a wire-stripping tool to remove approximately 0.75 inch (19 mm) of the covering from the end of the grounding wire. We recommend 6-AWG wire for the U.S. installations.
- Step 2** Insert the stripped end of the grounding wire into the open end of the grounding lug. Use a crimping tool to crimp the lug to the wire, see the following figure. Verify that the ground wire is securely attached to the grounding lug by attempting to pull the wire out of the crimped lug.

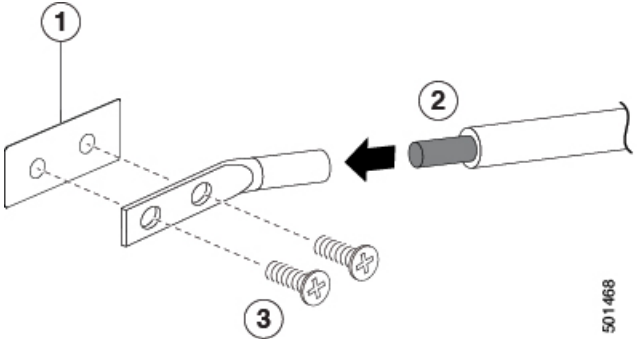

1	Chassis grounding pad	3	2 M4 screws are used to secure the grounding lug to the chassis
2	Grounding cable, with 0.75 in. (19 mm) of insulation that is stripped from one end, which is inserted into the grounding lug and crimped in place		

- Step 3** Secure the grounding lug to the chassis grounding pad with two M4 screws, see the previous figure. Tighten the screws to 11 to 15 in-lb (1.24 to 1.69 N·m) of torque.
- Step 4** Prepare the other end of the grounding wire and connect it to the facility ground.

Starting the Switch

You start the switch by connecting it to its dedicated power source. If you need $n+1$ redundancy, you must connect each of the power supplies to one or two power sources. If you need $n+n$ redundancy, you must connect each power supply in a switch to a different power source.

Before you begin

- The switch must be installed and secured to a rack or cabinet.
- The switch must be adequately grounded.
- The rack must be close enough to the dedicated power source so that you can connect the switch to the power source by using a designated power cables.
- You have the designated power cables for the power supplies that you are connecting to the dedicated power sources.



Note Depending on the outlet receptacle on your AC power distribution unit, you might need an optional jumper power cord to connect the switch to your outlet receptacle.

- The switch is not connected to the network (this includes any management or interface connections).
- The fan and power supply modules are fully secured in their chassis slots.

Step 1 For each AC power supply, do the following:

- a) Using the recommended AC power cable for your country or region, connect one end to the AC power supply.
- b) Connect the other end of the power cable to the AC power source.

Step 2 For each HVAC/HVDC power supply, connect it to a power source as follows:

- a) Using the recommended high voltage power cable for your country or region, connect the Anderson Power Saf-D-Grid connector on the power cable to the power receptacle on the power supply. Make sure that the connector clicks when fully pushed into the receptacle.
- b) Connect the other end of the power cable to a power source.
 - When connecting to an HVAC power source, insert the C14 or LS-25 plug in a receptacle for the HVAC power source.
 - When connecting to an HVDC power source, do the following:
 1. Verify that the power is turned off at a circuit breaker for the power source terminals.
 2. Remove the nuts from each of the terminal posts for the power supply.
 3. Place the power cable negative-wire terminal ring on the negative terminal for the power source and secure them with a terminal nut.
 4. Place the power cable positive-wire terminal ring on the positive terminal for the power source and secure them with a terminal nut.

5. Place the power cable ground-wire terminal ring on the ground terminal for the power source and secure them with a terminal nut.
6. If there is a safety cover for the power source terminals, place and secure it over the terminals to avoid an electrical shock hazard.
7. Turn on the power at the power source circuit breaker.

Step 3 For each DC power supply, do the following:

- a) Turn off the circuit breaker for the power source to avoid an electrical shock hazard.
- b) Verify that the power cable wires from the power source are connected to a connector block.
- c) Insert the connector block into the receptacle on the power supply. Make sure that the connector block clicks when fully inserted in the receptacle and does not pull out.
- d) If there is a safety cover for the terminals, place and secure it over the terminals to avoid an electrical shock hazard.
- e) Turn on the power at the circuit breaker for the DC power source.

Step 4 Verify that the power supply  LED is on and green.

Step 5 Listen for the fans; they should begin operating when the power supply is powered.

Step 6 After the switch boots, verify that the following LEDs are lit:

- On the fan modules, the Status (STA or STS) LED is green.
If a fan module Status LED is not green, try reinstalling the fan module.
- After initialization, the switch chassis Status (labeled as STA or STS) LED is green.

Step 7 Verify that the system software has booted and the switch has initialized without error messages.

A setup utility automatically launches the first time that you access the switch and guides you through the basic configuration. For instructions on how to configure the switch and check module connectivity, see the appropriate Cisco Nexus 9000 Series configuration guide.
