



Cisco Nexus 93360YC-FX2 NX-OS Mode Switch Hardware Installation Guide

First Published: 2019-07-20

Last Modified: 2020-07-22

Americas Headquarters

Cisco Systems, Inc.
170 West Tasman Drive
San Jose, CA 95134-1706
USA
<http://www.cisco.com>
Tel: 408 526-4000
800 553-NETS (6387)
Fax: 408 527-0883

THE SPECIFICATIONS AND INFORMATION REGARDING THE PRODUCTS REFERENCED IN THIS DOCUMENTATION ARE SUBJECT TO CHANGE WITHOUT NOTICE. EXCEPT AS MAY OTHERWISE BE AGREED BY CISCO IN WRITING, ALL STATEMENTS, INFORMATION, AND RECOMMENDATIONS IN THIS DOCUMENTATION ARE PRESENTED WITHOUT WARRANTY OF ANY KIND, EXPRESS OR IMPLIED.

The Cisco End User License Agreement and any supplemental license terms govern your use of any Cisco software, including this product documentation, and are located at: <http://www.cisco.com/go/softwareterms>. Cisco product warranty information is available at <http://www.cisco.com/go/warranty>. US Federal Communications Commission Notices are found here <http://www.cisco.com/c/en/us/products/us-fcc-notice.html>.

IN NO EVENT SHALL CISCO OR ITS SUPPLIERS BE LIABLE FOR ANY INDIRECT, SPECIAL, CONSEQUENTIAL, OR INCIDENTAL DAMAGES, INCLUDING, WITHOUT LIMITATION, LOST PROFITS OR LOSS OR DAMAGE TO DATA ARISING OUT OF THE USE OR INABILITY TO USE THIS MANUAL, EVEN IF CISCO OR ITS SUPPLIERS HAVE BEEN ADVISED OF THE POSSIBILITY OF SUCH DAMAGES.

Any products and features described herein as in development or available at a future date remain in varying stages of development and will be offered on a when-and if-available basis. Any such product or feature roadmaps are subject to change at the sole discretion of Cisco and Cisco will have no liability for delay in the delivery or failure to deliver any products or feature roadmap items that may be set forth in this document.

Any Internet Protocol (IP) addresses and phone numbers used in this document are not intended to be actual addresses and phone numbers. Any examples, command display output, network topology diagrams, and other figures included in the document are shown for illustrative purposes only. Any use of actual IP addresses or phone numbers in illustrative content is unintentional and coincidental.

The documentation set for this product strives to use bias-free language. For the purposes of this documentation set, bias-free is defined as language that does not imply discrimination based on age, disability, gender, racial identity, ethnic identity, sexual orientation, socioeconomic status, and intersectionality. Exceptions may be present in the documentation due to language that is hardcoded in the user interfaces of the product software, language used based on RFP documentation, or language that is used by a referenced third-party product.

Cisco and the Cisco logo are trademarks or registered trademarks of Cisco and/or its affiliates in the U.S. and other countries. To view a list of Cisco trademarks, go to this URL: [www.cisco.com go trademarks](http://www.cisco.com/go/trademarks). Third-party trademarks mentioned are the property of their respective owners. The use of the word partner does not imply a partnership relationship between Cisco and any other company. (1721R)

© 2019 Cisco Systems, Inc. All rights reserved.



CONTENTS

CHAPTER 1

Overview 1

Overview 1

CHAPTER 2

Preparing the Site 7

Temperature Requirements 7

Humidity Requirements 7

Altitude Requirements 8

Dust and Particulate Requirements 8

Minimizing Electromagnetic and Radio Frequency Interference 8

Shock and Vibration Requirements 9

Grounding Requirements 9

Planning for Power Requirements 9

Airflow Requirements 11

Rack and Cabinet Requirements 11

Clearance Requirements 12

CHAPTER 3

Installing the Chassis 15

Installation Options with Rack-Mount Kits 15

Install a Rack 15

Unpacking and Inspecting a New Switch 16

Planning How to Position the Chassis in the Rack 17

Installing the Chassis in a Four-Post Rack 17

Installing the Switch using the N9K-C9300-RMK Rack-mount Kit 18

Attaching the Bottom-Support Rails to the Rack 18

Attaching Front-Mount Brackets to the Chassis 20

Installing the Chassis in a Four-Post Rack 21

Installing the Airflow Vent NXA-ACC-BAV4 23

Grounding the Chassis 25

Starting the Switch 26

CHAPTER 4 **Connecting the Switch to the Network 29**

Overview of Network Connections 29

Connecting a Console to the Switch 30

Creating the Initial Switch Configuration 31

Setting Up the Management Interface 32

Connecting Interface Ports to Other Devices 33

Uplink Connections 33

Downlink Connections 33

CHAPTER 5 **Replacing Components 35**

Replacing a Fan Module During Operations 35

Replacing a Power Supply Module 36

 Removing an AC Power Supply 36

 Removing an HVAC/HVDC Power Supply 37

 Removing a DC Power Supply 37

 Installing an AC Power Supply 38

 Installing an HVAC/HVDC Power Supply 39

 Installing a DC Power Supply 39

APPENDIX A **Rack Specifications 41**

Overview of Racks 41

General Requirements for Cabinets and Racks 41

Requirements Specific to Standard Open Racks 42

Requirements Specific to Perforated Cabinets 42

Cable Management Guidelines 42

APPENDIX B **System Specifications 43**

Environmental Specifications 43

Switch Dimensions 43

Switch and Module Weights and Quantities 44

Transceiver and Cable Specifications	44
Switch Power Input Requirements	44
Power Specifications	45
1200-W AC Power Supply Specifications	45
1200-W HVAC/HVDC Power Supply Specifications	45
930-W DC Power Supply Specifications	46
Power Cable Specifications	46
Power Cable Specifications for AC Power Supplies	47
HVAC/HVDC Power Cables Supported by ACI-Mode and NX-OS Mode Switches	48
DC Power Cable Specifications	49
Regulatory Standards Compliance Specifications	49

APPENDIX C

LEDs	51
Switch Chassis LEDs	51
Fan Module LEDs	52
Power Supply LEDs	52

APPENDIX D

Additional Kits	55
Rack Mount Kit N9K-C9300-RMK	55
Vent Bracket	55



CHAPTER 1

Overview

- [Overview, on page 1](#)

Overview

The Cisco Nexus 93360YC-FX2 switch (N9K-C93360YC-FX2) is a 2-rack unit (RU), fixed-port switch designed for deployment in data centers. This switch has the following ports:

- 96 10-/25-Gigabit SFP28 ports
- 12 40/100-Gigabit QSFP28 ports
- Two management ports (one RJ-45 port and one SFP port)
- One console port
- 1 USB port

This switch includes the following user-replaceable components:

- Fan modules (three) with the following airflow choices:
 - Port-side exhaust fan module with blue coloring (NXA-FAN-160CFM-PE)
 - Port-side intake fan module with burgundy coloring (NXA-FAN-160CFM-PI)



Note Each fan module has two rotors. The switch can function normally if one rotor inside the any one fan module fails. In case of more than one rotor failure, the switch will issue a warning and power down in 2 minute.

- Power supply modules (two—One for operations and one for redundancy [1+1]) with the following choices:
 - 1200-W port-side exhaust AC power supply with blue coloring (NXA-PAC-1200W-PE)
 - 1200-W port-side intake AC power supply with burgundy coloring (NXA-PAC-1200W-PI)
 - 1200-W HVAC/HVDC dual-direction airflow power supply with white coloring (N9K-PUV-1200W)
 - 930-W port-side exhaust DC power supply with blue coloring (NXA-PDC-930W-PE)

- 930-W port-side intake DC power supply with burgundy coloring (NXA-PDC-930W-PI)



Note 930-W DC power supply support 1+1 redundancy requires both of the following conditions:

- Ambient temperature of 104°F (40°C) or less and
- Use of 3.5 W QSFP+ transceivers or passive QSFP cables

With higher temperatures or other optics, the switch requires both power supplies for operations without power redundancy.



Note Both power supplies are the same type. Do not mix AC, DC, or HVAC/HVDC power supplies.







Note All fan modules and power supplies must use the same airflow direction. If you are using the 1200-W HVAC/HVDC power supplies, those power supplies automatically use the same airflow direction as used by the fan modules.

Deployment Scheme for SFP-10G-T-X Transceivers

The following figure shows the maximum configuration density of SFP-10G-T-X SFP+ transceivers for this switch.

1	3	5	7	9	11	13	15	17	19	21	23	25	27	29	31	33	35	37	39	41	43	45	47	97	99	101
2	4	6	8	10	12	14	16	18	20	22	24	26	28	30	32	34	36	38	40	42	44	46	48	98	100	102
49	51	53	55	57	59	61	63	65	67	69	71	73	75	77	79	81	83	85	87	89	91	93	95	103	105	107
50	52	54	56	58	60	62	64	66	68	70	72	74	76	78	80	82	84	86	88	90	92	94	96	104	106	108

	<p>Active Port deploying the SFP+ 10GBASE-T transceiver, with max power consumption up to 2.5W.</p> <p>Once configured with “media-type 10g-tx” in NX-OS or “Link Level Policy -> Physical Media Type -> SFP 10G TX” in ACI, these ports can deploy SFP-10G-T-X. Without such configuration, they behave like normal ports.</p>
	<p>Port Shutdown or Active with Passive Copper Cables only (Max. power consumption up to 0.1W).</p> <p>Once 10g-tx is configured on yellow ports, ports to the left, right, top and bottom of the yellow port are referenced as blue ports. These adjacent ports will then support only low power Passive Copper DAC cable, or these can be left empty to conserve power. If 10g-tx configuration is removed from adjacent yellow ports, the blue ports will revert to behaving like normal ports.</p>
	<p>Active Port deploying any Cisco 1/10/25G optics (SFP, SFP+, SFP28) EXCLUDING SFP+ 10GBASE-T, with max power consumption up to 1.5W. These ports are not part of any scheme and can deploy all regular Cisco optics and behave like normal ports.</p>

	Active Uplink QSFP+, QSFP28 ports with Incoming and outgoing traffic (40G/100G).
---	--

The following figure shows the switch features on the port side of the chassis.

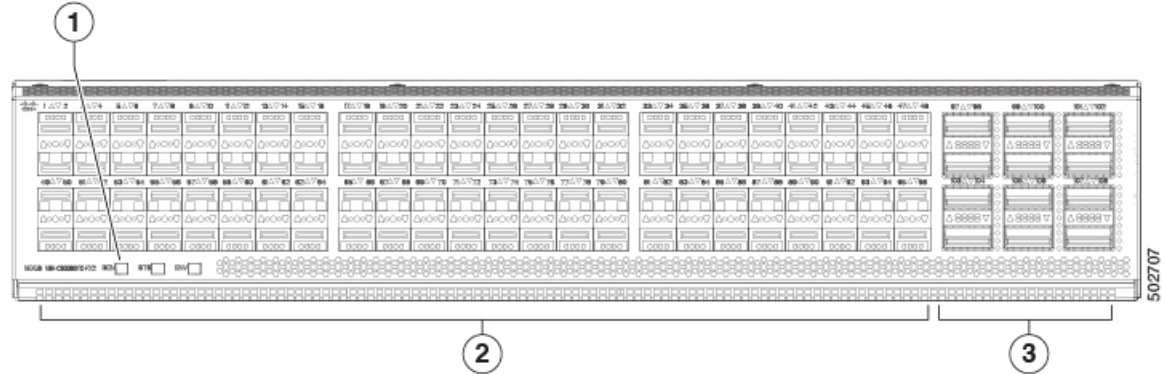

1	Beacon (BCN), Status (STS), and Environment (ENV) LEDs	3	12 40/100-Gigabit QSFP28 ports
2	96 10-/25-Gigabit SFP28 ports		

To determine which transceivers, adapters, and cables are support this switch, see the [Cisco Transceiver Modules Compatibility Information](#) document.

The following figure shows the switch features on the power supply side of the chassis.

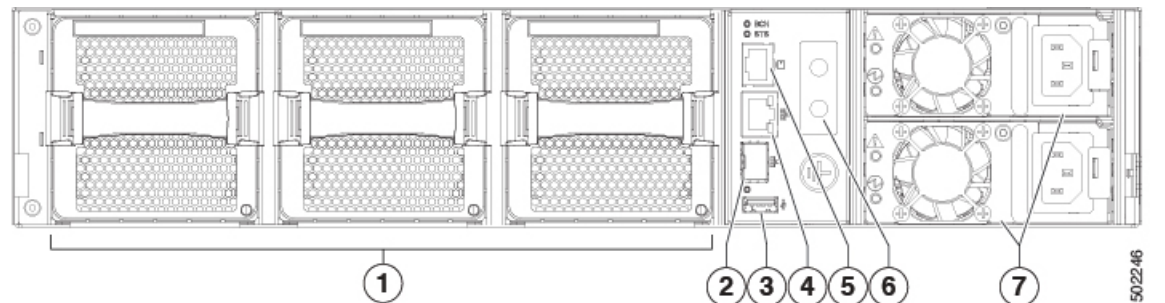

1	Fan modules (3) with slots numbered from 1 (left) to 3 (right)	5	Console port (1)
2	Management port (1—SFP optical port)	6	Grounding pad
3	USB port (1)	7	Power supply modules (1 or 2) (AC power supplies shown) with slots numbered 1 (top) and 2 (bottom)
4	Management port (1—RJ-45 copper port)		

The following figure shows the side of the chassis.

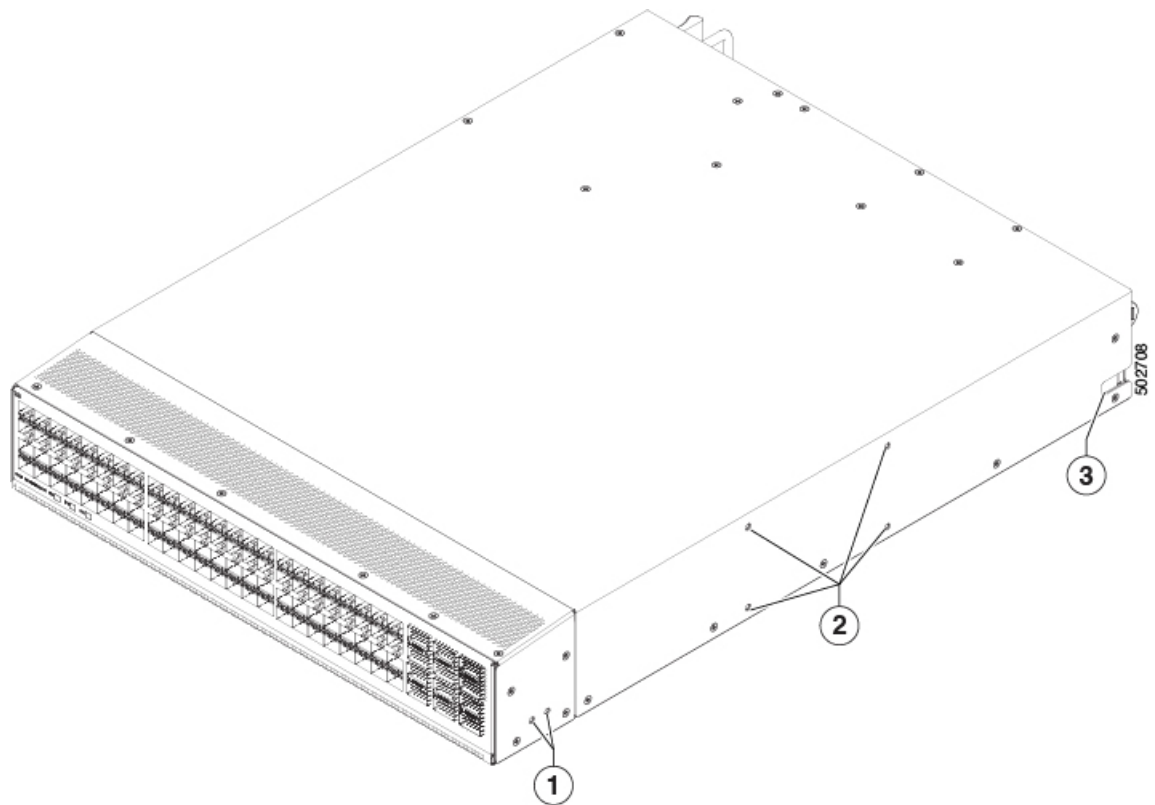

1	Screw holes for front mounting brackets (4-post rack installations)	3	Notch on both sides of the chassis for locking the power supply end of the chassis to the bottom support rails (4-post rack installations).
2	Screw holes for center-mount bracket (2-post rack installations)		

Depending on whether you plan to position the ports in a hot or cold aisle, you can order the fan and power supply modules with port-side intake or port-side exhaust airflow. For port-side intake airflow, the fan and AC power supply modules have burgundy coloring. For port-side exhaust airflow, the fan and AC power supplies have blue coloring. You can also order the 1200-W HVAC/HVDC power supply which has dual-direction airflow with white coloring. Dual-direction airflow modules automatically use the airflow direction of the other modules installed in the switch.

The fan and power supply modules are field replaceable. You can replace one fan module or one power supply module during operations so long as the other modules are installed and operating. If you have only one power supply installed, you can install the replacement power supply in the open slot before removing the original power supply.



Note All fan and power supply modules must have the same direction of airflow. Otherwise, the switch can overheat and shut down. If you are installing a dual-direction power supply, that module automatically uses the same airflow direction as the other modules in the switch.

**Caution**

If the switch has port-side intake airflow (burgundy coloring for fan modules), you must locate the ports in the cold aisle. If the switch has port-side exhaust airflow (blue coloring for fan modules), you must locate the ports in the hot aisle. If you locate the air intake in a hot aisle, the switch can overheat and shut down.



CHAPTER 2

Preparing the Site

- [Temperature Requirements, on page 7](#)
- [Humidity Requirements, on page 7](#)
- [Altitude Requirements, on page 8](#)
- [Dust and Particulate Requirements, on page 8](#)
- [Minimizing Electromagnetic and Radio Frequency Interference, on page 8](#)
- [Shock and Vibration Requirements, on page 9](#)
- [Grounding Requirements, on page 9](#)
- [Planning for Power Requirements, on page 9](#)
- [Airflow Requirements, on page 11](#)
- [Rack and Cabinet Requirements, on page 11](#)
- [Clearance Requirements, on page 12](#)

Temperature Requirements

The switch requires an operating temperature of 32 to 104 degrees Fahrenheit (0 to 40 degrees Celsius). If the switch is not operating, the temperature must be between –40 to 158 degrees Fahrenheit (–40 to 70 degrees Celsius).

Humidity Requirements

High humidity can cause moisture to enter the switch. Moisture can cause corrosion of internal components and degradation of properties such as electrical resistance, thermal conductivity, physical strength, and size. The switch is rated to withstand from 5- to 95-percent (nonoperating) and 5- to 90-percent (operating) relative humidity.

Buildings in which the climate is controlled by air-conditioning in the warmer months and by heat during the colder months usually maintain an acceptable level of humidity for the switch equipment. However, if the switch is located in an unusually humid location, use a dehumidifier to maintain the humidity within an acceptable range.

Altitude Requirements

Altitude rating is based on power supply installed; see critical components list in the system CB report for altitude rating.

Dust and Particulate Requirements

Exhaust fans cool power supplies and system fans cool switches by drawing in air and exhausting air out through various openings in the chassis. However, fans also ingest dust and other particles, causing contaminant buildup in the switch and increased internal chassis temperature. Dust and particles can act as insulators and interfere with the mechanical components in the switch. A clean operating environment can greatly reduce the negative effects of dust and other particles.

In addition to keeping your environment free of dust and particles, follow these precautions to avoid contamination of your switch:

- Do not permit smoking near the switch.
- Do not permit food or drink near the switch.

Minimizing Electromagnetic and Radio Frequency Interference

Electromagnetic interference (EMI) and radio frequency interference (RFI) from the switch can adversely affect other devices, such as radio and television (TV) receivers. Radio frequencies that emanate from the switch can also interfere with cordless and low-power telephones. Conversely, RFI from high-power telephones can cause spurious characters to appear on the switch monitor.

RFI is defined as any EMI with a frequency above 10 kHz. This type of interference can travel from the switch to other devices through the power cable and power source or through the air as transmitted radio waves. The Federal Communications Commission (FCC) publishes specific regulations to limit the amount of EMI and RFI that are emitted by computing equipment. Each switch meets these FCC regulations.

To reduce the possibility of EMI and RFI, follow these guidelines:

- Cover all open expansion slots with a blank filler plate.
- Always use shielded cables with metal connector shells for attaching peripherals to the switch.

When wires are run for any significant distance in an electromagnetic field, interference can occur to the signals on the wires with the following implications:

- Bad wiring can result in radio interference emanating from the plant wiring.
- Strong EMI, especially when it is caused by lightning or radio transmitters, can destroy the signal drivers and receivers in the chassis and even create an electrical hazard by conducting power surges through lines into equipment.



Note To predict and prevent strong EMI, you need to consult experts in radio frequency interference (RFI).

The wiring is unlikely to emit radio interference if you use a twisted-pair cable with a good distribution of grounding conductors. If you exceed the recommended distances, use a high-quality twisted-pair cable with one ground conductor for each data signal when applicable.



Caution If the wires exceed the recommended distances, or if wires pass between buildings, give special consideration to the effect of a lightning strike in your vicinity. The electromagnetic pulse that is caused by lightning or other high-energy phenomena can easily couple enough energy into unshielded conductors to destroy electronic switches. You will want to consult experts in electrical surge suppression and shielding if you had similar problems in the past.

Shock and Vibration Requirements

The switch has been shock- and vibration-tested for operating ranges, handling, and earthquake standards.

Grounding Requirements

The switch is sensitive to variations in voltage that is supplied by the power sources. Overvoltage, undervoltage, and transients (or spikes) can erase data from memory or cause components to fail. To protect against these types of problems, ensure that there is an earth-ground connection for the switch. You can connect the grounding pad on the switch either directly to the earth-ground connection or to a fully bonded and grounded rack.

When you properly install the chassis in a grounded rack, the switch is grounded because it has a metal-to-metal connection to the rack. Alternatively, you can ground the chassis by using a customer-supplied grounding cable that meets your local and national installation requirements. For U.S. installations, we recommend 6-AWG wire. Connect your grounding cable to the chassis with a grounding lug (provided in the switch accessory kit) and to the facility ground.



Note You automatically ground AC power supplies when you connect them to AC power sources. For DC power supplies, you must connect a grounding wire when wiring the power supply to the DC power source.



Note An electrical conducting path shall exist between the product chassis and the metal surface of the enclosure or rack in which it is mounted or to a grounding conductor. Electrical continuity shall be provided by using thread-forming type mounting screws that remove any paint or non-conductive coatings and establish a metal-to-metal contact. Any paint or other non-conductive coatings shall be removed on the surfaces between the mounting hardware and the enclosure or rack. The surfaces shall be cleaned and an antioxidant applied before installation.

Planning for Power Requirements

The switch includes two power supplies (1-to-1 redundancy with current sharing) in one of the following combinations:

- Two 1200-W AC power supplies
- Two 1200-W HVAC/HVDC power supplies
- Two 930-W DC power supplies



Note For $n+1$ redundancy, you can use one or two power sources for the two power supplies. For $n+n$ redundancy, you must use two power sources and connect each power supply to a separate power source.

The power supplies are rated to output up to 1200 W (AC and HVAC/HVDC power supplies) to the switch, but the switch requires less than that amount of power from the power supply. To operate the switch, you must provision enough power from the power source to cover the requirements of both the switch and a power supply. Typically, this switch and a power supply require about 429 W of power input from the power source, but you must provision as much as 1245 W power input from the power source to cover peak demand.



Note Some of the power supply modules have rating capabilities that exceed the switch requirements. When calculating your power requirements, use the switch requirements to determine the amount of power that is required for the power supplies.

To minimize the possibility of circuit failure, make sure that each power-source circuit that is used by the switch is dedicated to the switch.



Note For AC input application, please refer to the following statement:



Warning **Statement 1005**—Circuit Breaker when using AC power supplies

This product relies on the building's installation for short-circuit (overcurrent) protection. Ensure that the protective devices are rated not greater than 20A (North America), 16A (Europe), and 13A (UK).



Note For DC input application, please refer to the following statement:



Warning **Statement 1005**—Circuit Breaker when using DC power supplies

This product relies on the building's installation for short-circuit (overcurrent) protection.

- Ensure that the protective devices are rated not greater than 30A when the switch is powered with regular DC power supplies (rated 48-60VDC).
 - Ensure that the protective devices are rated not greater than 10A when the switch is powered with HVDC power supplies (rated 240-350VDC).
-



Warning Statement 1033

Connect the unit only to DC power source that complies with the Safety Extra-Low Voltage (SELV) requirements in IEC 60950 based safety standards.



Note We recommend 8-AWG wire for DC installations in the U.S.

Airflow Requirements

The switch is positioned with its ports in either the front or the rear of the rack depending on your cabling and maintenance requirements.

To identify the airflow options for your switch, see the user-replaceable components in the *Overview* section of this document.

You must have fan and power supply modules that move the coolant air from the cold aisle to the hot aisle in one of the following ways:

- Port-side exhaust airflow—Cool air enters the chassis through the fan and power supply modules in the cold aisle and exhausts through the port end of the chassis in the hot aisle.
- Port-side intake airflow—Cool air enters the chassis through the port end in the cold aisle and exhausts through the fan and power supply modules in the hot aisle.

You can identify the airflow direction of each fan and power supply module by its coloring as follows:

- Blue coloring indicates port-side exhaust airflow.
- Burgundy coloring indicates port-side intake airflow.



Note To prevent the switch from overheating and shutting down, you must position the air intake for the switch in a cold aisle. The fan and power supply modules must have the same direction of airflow (even if their coloring is different). If you must change the airflow direction for the switch, you must shutdown the switch before changing the modules.

Rack and Cabinet Requirements

You can install the following types of racks or cabinets for your switch:

- Standard perforated cabinets
- Solid-walled cabinets with a roof fan tray (bottom-to-top cooling)
- Standard open four-post Telco racks

Work with your cabinet vendors to determine which of their cabinets meet the following requirements or see the Cisco Technical Assistance Center (TAC) for recommendations:

- Use a standard 19-inch (48.3-cm), four-post Electronic Industries Alliance (EIA) cabinet or rack with mounting rails that conform to English universal hole spacing per section 1 of the ANSI/EIA-310-D-1992 standard.
- The depth of a four-post rack must be 24 to 32 inches (61.0 to 81.3 cm) between the front and rear mounting rails (for proper mounting of the bottom-support brackets or other mounting hardware).

Also, you must have power receptacles that are located within reach of the power cords that are used with the switch.



Warning Statement 1048—Rack Stabilization

The rack stabilizing mechanism must be in place, or the rack must be bolted to the floor before installation or servicing. Failure to stabilize the rack can cause bodily injury.

Clearance Requirements

Provide the chassis with adequate clearance between the chassis and any other rack, device, or structure so that you can properly install the chassis. Provide the chassis with adequate clearance to route cables, provide airflow, and maintain the switch. For the clearances required for an installation of this chassis in a four-post rack, see the following figure.

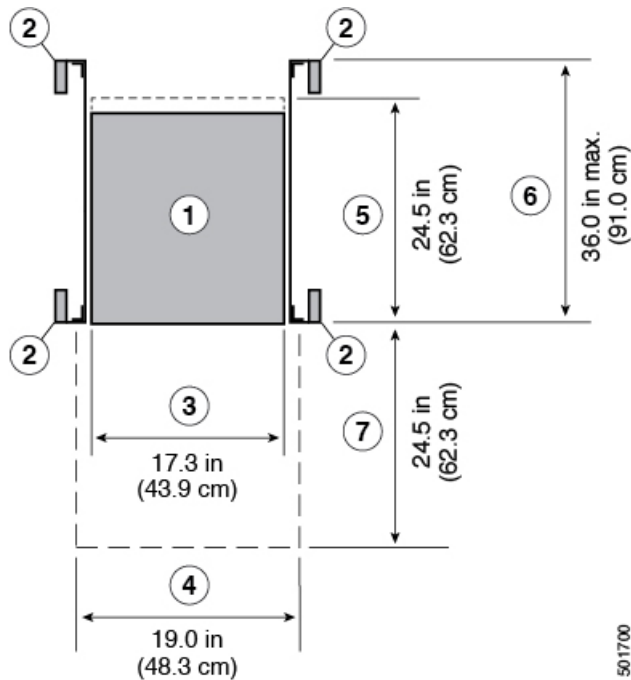

1	Chassis	5	Depth of the chassis
---	---------	---	----------------------

2	Vertical rack-mount posts and rails	6	Maximum extension of the bottom-support rails 36.0 in (91.0 cm)
3	Chassis width 17.3 in (43.9 cm)	7	Depth of the front clearance area (equal to the depth of the chassis).
4	Width of the front clearance area (equal to the width of the chassis with two rack-mount brackets that are attached to it). 19.0 in (48.3 cm)		



Note Both the front and rear of the chassis must be open to both aisles for airflow.



CHAPTER 3

Installing the Chassis

- [Installation Options with Rack-Mount Kits, on page 15](#)
- [Install a Rack, on page 15](#)
- [Unpacking and Inspecting a New Switch, on page 16](#)
- [Planning How to Position the Chassis in the Rack, on page 17](#)
- [Installing the Chassis in a Four-Post Rack, on page 17](#)
- [Installing the Airflow Vent NXA-ACC-BAV4, on page 23](#)
- [Grounding the Chassis, on page 25](#)
- [Starting the Switch, on page 26](#)

Installation Options with Rack-Mount Kits

The rack-mount kit enables you to install the switch into racks of varying depths. You can position the switch with easy access to either the port connections or the fan and power supply modules.

You can install the switch using the following rack-mount options:

- Rack-mount kit (N9K-C9300-RMK) which you can order from Cisco.

For four post racks.

The rack or cabinet that you use must meet the requirements listed the in [General Requirements for Cabinets and Racks, on page 41](#) section.



Note You are responsible for verifying that your rack and rack-mount hardware comply with the guidelines that are described in this doc.

Install a Rack

Before you install the switch, you must install a standard four-post, 19-inch EIA data center rack (or a cabinet that contains such a rack) that meets the requirements listed in [Overview of Racks, on page 41](#).

Step 1 Bolt the rack to the concrete subfloor before moving the chassis onto it.

Warning Statement 1048—Rack Stabilization

The rack stabilizing mechanism must be in place, or the rack must be bolted to the floor before installation or servicing. Failure to stabilize the rack can cause bodily injury.

Step 2 If the rack has bonded construction, connect it to the earth ground. This action enables you to easily ground the switch and its components and to ground your electrostatic discharge (ESD) wrist strap to prevent damaging discharges when you handle ungrounded components before installing them.

Step 3 Include one or two power sources at the rack. For AC power, provide a power receptacle. For DC power, provide a circuit breaker with terminals for connecting power cables.

Warning Statement 1018—Supply Circuit

To reduce risk of electric shock and fire, take care when connecting units to the supply circuit so that wiring is not overloaded.

Note If you are not using power redundancy or are using $n+1$ redundancy, you need only one power source. If you are using $n+n$ redundancy, you need two power sources.

Unpacking and Inspecting a New Switch

Before you install a new chassis, you need to unpack and inspect it to be sure that you have all the items that you ordered and verify that the switch was not damaged during shipment. If anything is damaged or missing, contact your customer representative immediately.



Caution When you handle the chassis or its components, you must follow ESD protocol at all times to prevent ESD damage. This protocol includes but is not limited to wearing an ESD wrist strap that you connect to the earth ground.



Tip Do not discard the shipping container when you unpack the switch. Flatten the shipping cartons and store them. If you need to move or ship the system in the future, you will need this container.

Step 1 Compare the shipment to the equipment list that is provided by your customer service representative and verify that you have received all of the ordered items.

The shipment should include the following:

- Switch chassis, which includes the following installed components:
 - Two power supplies (any combination of the following with the airflow direction being the same as for the fan modules):
 - fan modules (all fan and power supply modules must have the same airflow direction)
- Switch accessory kit

Step 2 Check the contents of the box for damage.

Step 3 If you notice any discrepancies or damage, send the following information to your customer service representative by email:

- Invoice number of the shipper (see the packing slip)
- Model and serial number of the missing or damaged unit
- Description of the problem and how it affects the installation

Planning How to Position the Chassis in the Rack

The switch is designed so that you can have coolant air flow through the switch in one of the two following directions:

- Enter the port side and exhaust out the power supply side (port-side intake airflow)
- Enter the power supply side and exhaust out the port side (port-side exhaust airflow)

For port-side intake airflow, the switch must have port-side intake fan and AC power supply modules with one or more of the following colorings:

- Burgundy coloring on fan modules and AC power supplies

For port-side exhaust airflow, the switch must have port-side exhaust fan and AC power supply modules with one or more of the following colorings:

- Blue coloring on fan modules and AC power supplies

You can plan the positioning of the switch so that its ports are located close to ports on connected devices or so that the fan and power supply modules are conveniently located in a maintenance aisle, and then order the modules that move coolant air in the appropriate direction from the cold aisle to the hot aisle.



Note All fan and power supply modules in the same switch must operate with the same direction of airflow and the air intake portion of the switch must be located in a cold aisle.

Installing the Chassis in a Four-Post Rack

Before you install the chassis, be sure that the rack is fully secured to the data center floor.

Installing the Switch using the N9K-C9300-RMK Rack-mount Kit

Attaching the Bottom-Support Rails to the Rack

The switch chassis that you are installing ships with two adjustable bottom-support rails that you can attach to a four-post rack to hold the chassis. Each of these bottom-support rails has two pieces—one that slides into the other so that you can adjust them to fit racks with front and rear mounting posts that are spaced less than 36 inches (91 cm). On each bottom-support rail, the rail half that slides into the other rail includes a chassis stop that fits into the module end of the chassis. Depending on direction of the chassis airflow, you need to position the rail half with the chassis stop so that the fan and power supply modules end up in the appropriate aisle as follows:

- Port-side intake (burgundy coloring for fan modules) airflow requires that the bottom-support rail with the chassis stop be located on the hot aisle side of the rack.
- Port-side exhaust (blue coloring for fan modules) airflow requires that the bottom-support rail with the chassis stop be located on the cold aisle side of the rack.



Warning **Statement 1074**—Comply with Local and National Electrical Codes

To reduce risk of electric shock or fire, installation of the equipment must comply with local and national electrical codes.

Before you begin

Before you can install the bottom support rails for the chassis, you must do the following:

- Verify that a four-post rack or cabinet is installed.
- If any other devices are stored in the rack or cabinet, verify that the heavier switches are installed below lighter switches.
- Verify that the bottom-support rails kit is included in the switch accessory kit.
- Verify that you have 8 screws for attaching the bottom support brackets to the racks (typically M6 x 10 mm screws or the screw appropriate for the vertical mounting rails on the rack).



Warning **Statement 1006**—Chassis Warning for Rack-Mounting and Servicing

To prevent bodily injury when mounting or servicing this unit in a rack, you must take special precautions to ensure that the system remains stable. The following guidelines are provided to ensure your safety:

- This unit should be mounted at the bottom of the rack if it is the only unit in the rack.
 - When mounting this unit in a partially filled rack, load the rack from the bottom to the top with the heaviest component at the bottom of the rack.
 - If the rack is provided with stabilizing devices, install the stabilizers before mounting or servicing the unit in the rack.
-

- Step 1** Look at the fan and power supply modules installed in the chassis to determine how you must position the bottom-support rails on the rack.
- If the fan modules have blue coloring (port-side exhaust modules), you must position the bottom support rails so that the chassis stop is positioned by the cold aisle.
 - If the fan modules have burgundy (port-side intake modules), you must position the bottom support rails so that the chassis stop is positioned by the hot aisle.
- Step 2** Separate the two sliders that make up one bottom-support rail and position the half with the chassis stop by the appropriate aisle for the fan and power supply modules. Also make sure that there is at least 1 rack unit open above the bottom-support rails so that you can easily install the chassis.
- Step 3** Use two customer-supplied screws (typically M6 x 10 mm screws) to attach the bottom-support rail half to the vertical mounting rails on the rack post. Tighten each screw to the appropriate torque setting for the screws (for M6 x 10 mm screws, use 40 in. lbs [4.5 N·m] of torque).
- Step 4** Slide the other half of the bottom-support rail onto the attached half of the rail set and use two customer supplied screws (typically M6 x 10 mm screws) to secure that portion to the vertical mounting rails on the rack. Tighten each screw to the appropriate torque setting for the screws (for M6 x 10 mm screws, use 40 in. lbs [4.5 N·m] of torque).

Figure 1: Positioning an Expanding Bottom-Support Rail Set

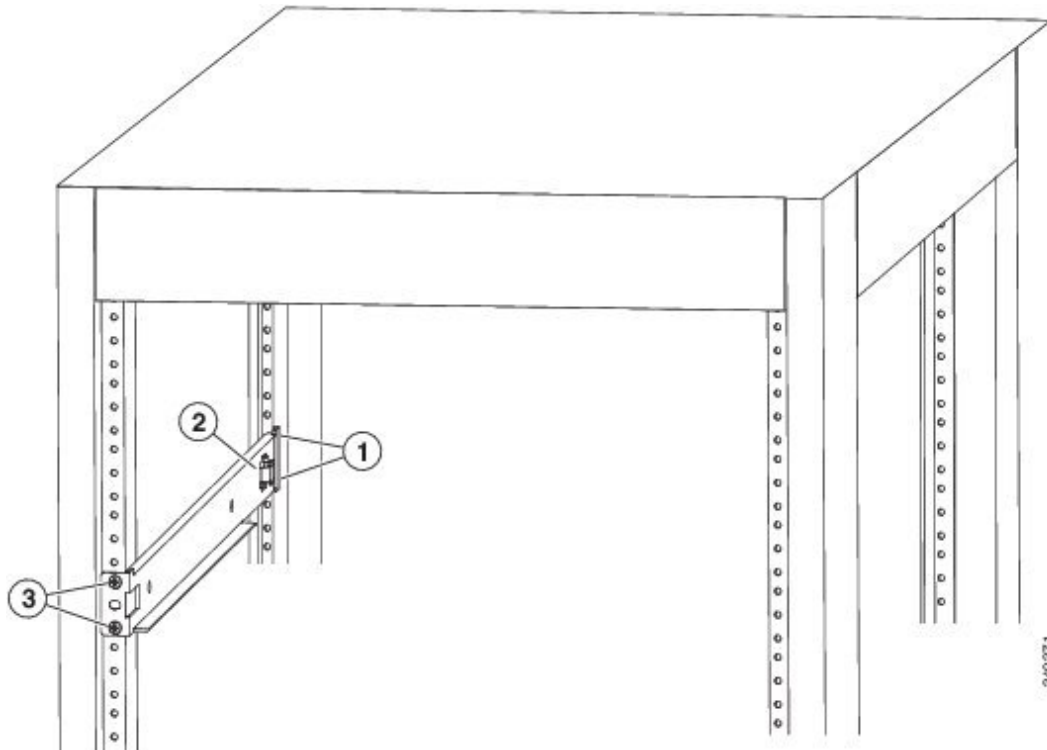

1	2 screws holding one end of the bottom-support bracket to the rear of the rack	3	2 screws holding the front end of the bottom-support bracket to the front side of the rack
2	Chassis stop on the expanding bottom-support bracket		

Step 5 Repeat Steps 2 and 3 to attach the other expanding bottom-support rails to the other side of the rack.

Note Check the two installed bottom support rails to be sure that both have their chassis stops by the same aisle (either both by the hot aisle or both by the cold aisle) and that both rails are level and level with each other. If they are not level, adjust the higher rail down to the level of the lower rail.

What to do next

You are ready to install two front-mount brackets on the chassis.

Attaching Front-Mount Brackets to the Chassis

You need to attach a right-angled bracket to each side of the chassis. This bracket holds the chassis in place on a four-post rack.

Before you begin

- You must have the following tools and equipment:
 - Manual Phillips-head torque screwdriver
 - Front-mount brackets (2) and screws (4) (found inside the switch accessory kit)

Step 1 Align the two holes in one side of one of two front-mount brackets to two holes on the left or right side of the chassis (see the following figure).

Be sure that the other side of the bracket is facing toward the front (port end) of the chassis.

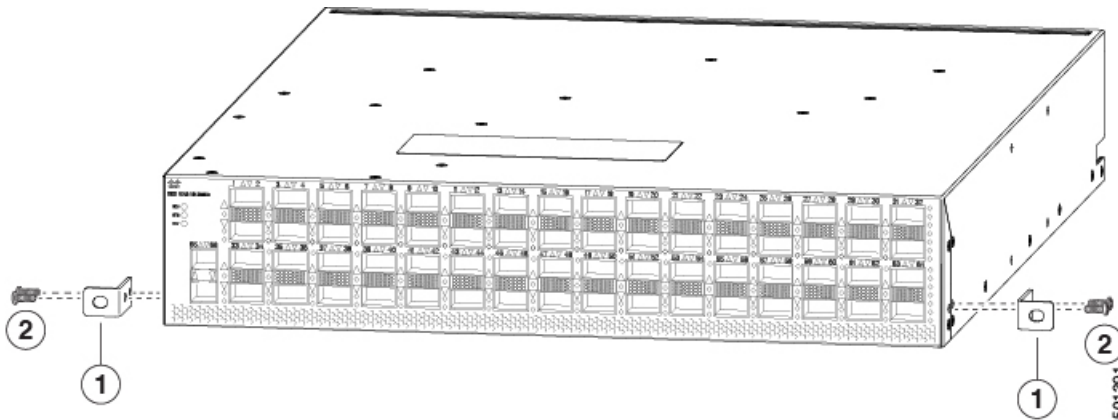

1	Front-mount bracket with two screw holes aligned to two screw holes in the chassis and one screw hole facing the front (port side) of the chassis.	2	Two M4 x 6 mm screws used to fasten the bracket to the chassis.
---	--	---	---

Step 2 Use two M4 x 6 mm screws to attach the bracket to the chassis. Tighten each screw to 11 to 15 in-lb (1.2 to 1.7 N·m).

Step 3 Repeat Steps 1 and 2 to attach the second center-mount bracket to the other side of the chassis.

What to do next

You are ready to mount the chassis to the four-post rack.

Installing the Chassis in a Four-Post Rack

You need to slide the chassis onto the bottom-support rails so that the power supply end locks onto the chassis stops at the end of the rails and so that the front-mount brackets on the chassis come into contact with the front-mount rails on the rack.



Warning Statement 1074—Comply with Local and National Electrical Codes

To reduce risk of electric shock or fire, installation of the equipment must comply with local and national electrical codes.



Warning Statement 1032—Lifting the Chassis

To prevent personal injury or damage to the chassis, never attempt to lift or tilt the chassis using the handles on modules (such as power supplies, fans, or cards); these types of handles are not designed to support the weight of the unit.

Before you begin

- Make sure that the four-post rack is properly installed and secured to the concrete subfloor.
- Make sure that the bottom-support rails are installed so that the fan modules will be in the appropriate aisle as follows:
 - Burgundy (port-side intake airflow) fan modules are positioned in a hot aisle (the chassis stop on the bottom-support rails is positioned by the hot aisle).
 - Blue colored (port-side exhaust airflow) fan modules are positioned in a cold aisle (the chassis stop on the bottom-support rails is positioned by the cold aisle).
- Make sure that two front-mount brackets are securely fastened to the sides of the chassis at the port end.
- Make sure that you have two customer-supplied rack-mount screws (M6 x 10 mm or appropriate screw for the vertical mounting rails on the rack).



Warning Statement 1006—Chassis Warning for Rack-Mounting and Servicing

To prevent bodily injury when mounting or servicing this unit in a rack, you must take special precautions to ensure that the system remains stable. The following guidelines are provided to ensure your safety:

- This unit should be mounted at the bottom of the rack if it is the only unit in the rack.
 - When mounting this unit in a partially filled rack, load the rack from the bottom to the top with the heaviest component at the bottom of the rack.
 - If the rack is provided with stabilizing devices, install the stabilizers before mounting or servicing the unit in the rack.
-

Step 1

Slide the power supply end of the chassis onto the bottom-support rails that are installed on the rack.

Be sure that the sides of the chassis by the power supplies clips into the chassis stops on the bottom-support rails and the front-mount brackets come in contact with the rack (see the following figure).

Note If the bottom-support rails are extended a long distance, they can bend outwards slightly when you install the chassis and the chassis stops at the far end of the rails might not fit into the end of the chassis. If this happens, press the side rails toward the sides of the chassis so that the chassis stops can go inside the chassis and hold it in place on the rack.

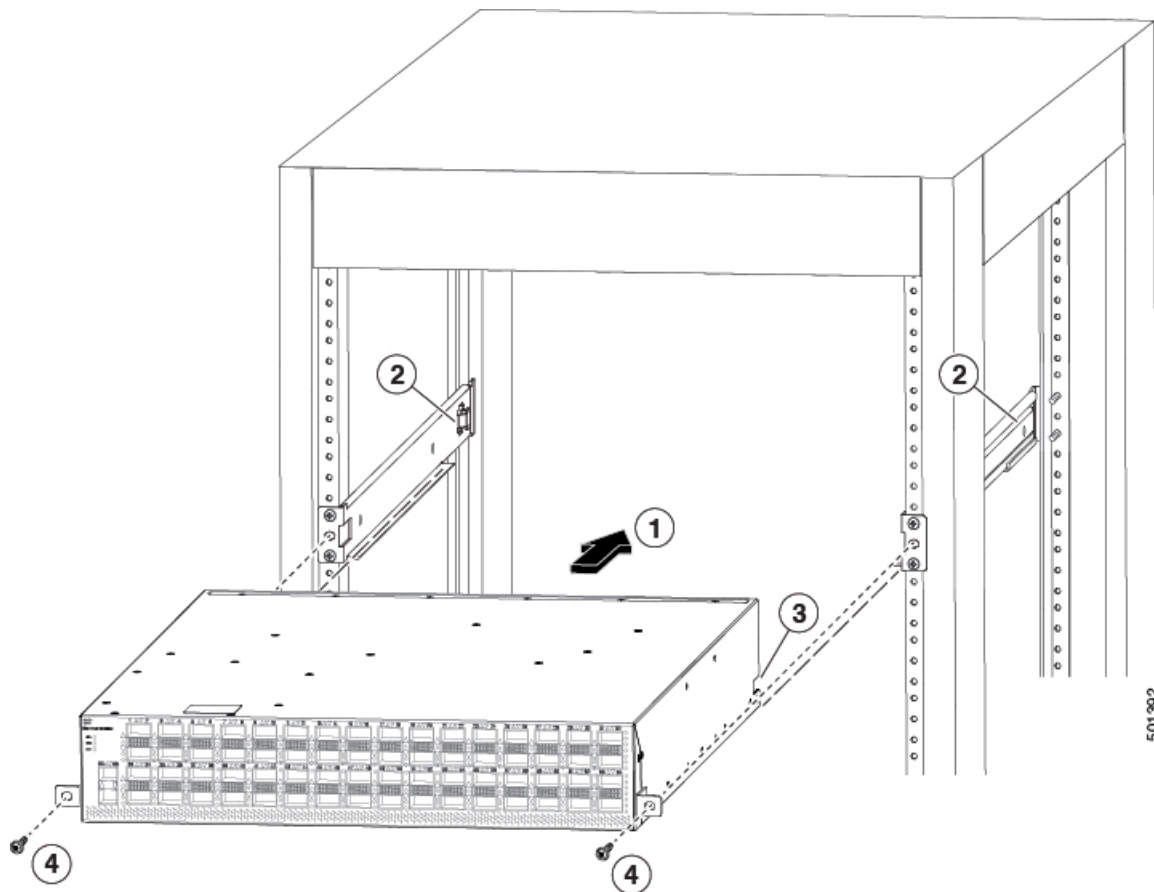

1	Slide the power-supply end of the chassis onto the bottom-support rails so that the chassis locks onto the chassis stops at the end of the rails.	3	Receiving hole on each side of the chassis for the chassis stops on the bottom-support rails.
2	Chassis stops for holding the chassis (positioned by the aisle required for the fan and power supply modules).	4	Customer-supplied rack-mount screw (M6 x 10 mm screw or other screw appropriate for the rack) used to secure each side of the chassis to the rack.

Step 2

Use a customer-supplied rack-mount screw (an M6 x 10 mm screw or other appropriate screw for the rack) to attach each of the two mounting brackets on the chassis to the rack and tighten each screw to the appropriate torque setting for the screw (for M6 x 10 mm screws, use 40 in-lbs [4.5 N·m] of torque).

Installing the Airflow Vent NXA-ACC-BAV4

The airflow vent bracket (NXA-ACC-BAV4) is required for NEBS (Network Equipment-Building System) compliance.



Note An electrical conducting path shall exist between the product chassis and the metal surface of the enclosure or rack in which it is mounted or to a grounding conductor. Electrical continuity shall be provided by using thread-forming type mounting screws that remove any paint or non-conductive coatings and establish a metal-to-metal contact. Any paint or other non-conductive coatings shall be removed on the surfaces between the mounting hardware and the enclosure or rack. The surfaces shall be cleaned and an antioxidant applied before installation.



Note You supply the 10-32 or 12-24 screws to mount the vent bracket and airflow sleeve.

Before you begin

- Verify that your shipment is complete.
- Install your rack in a secure location.

SUMMARY STEPS

1. Insert the vent bracket and attach it as follows:

DETAILED STEPS

Insert the vent bracket and attach it as follows:

- a) Holding the vent bracket (NXA-ACC-BAV4), position it in front and above the switch (see item 1 in the following figure).
- b) Holding the vent bracket level, insert screws (12-24 or 10-32, depending on the rack type) in each of the front rack-mount flanges (using a total of two screws) and into the cage nuts or threaded holes in the vertical rack-mounting rails (see item 2 in the following figure).

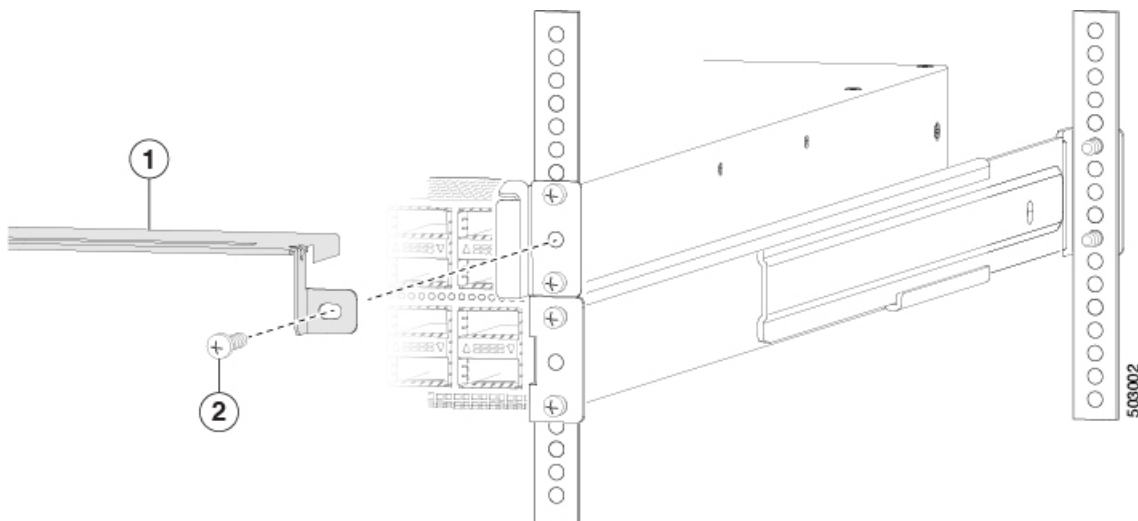

- c) Tighten the 10-32 screws to 20 in-lb (2.26 N·m) or tighten the 12-24 screws to 30 in-lb (3.39 N·m).

Grounding the Chassis

The switch chassis is automatically grounded when you properly install the switch in a grounded rack with metal-to-metal connections between the switch and rack.



Note An electrical conducting path shall exist between the product chassis and the metal surface of the enclosure or rack in which it is mounted or to a grounding conductor. Electrical continuity shall be provided by using thread-forming type mounting screws that remove any paint or non-conductive coatings and establish a metal-to-metal contact. Any paint or other non-conductive coatings shall be removed on the surfaces between the mounting hardware and the enclosure or rack. The surfaces shall be cleaned and an antioxidant applied before installation.

You can also ground the chassis, which is required if the rack is not grounded, by attaching a customer-supplied grounding cable. Attach the cable to the chassis grounding pad and the facility ground.



Warning **Statement 1024**—Ground Conductor

This equipment must be grounded. To reduce the risk of electric shock, never defeat the ground conductor or operate the equipment in the absence of a suitably installed ground conductor. Contact the appropriate electrical inspection authority or an electrician if you are uncertain that suitable grounding is available.



Warning **Statement 1046**—Installing or Replacing the Unit

To reduce risk of electric shock, when installing or replacing the unit, the ground connection must always be made first and disconnected last.

Before you begin

Before you can ground the chassis, you must have a connection to the earth ground for the data center building.

-
- Step 1** Use a wire-stripping tool to remove approximately 0.75 inch (19 mm) of the covering from the end of the grounding wire. We recommend 6-AWG wire for the U.S. installations.
- Step 2** Insert the stripped end of the grounding wire into the open end of the grounding lug. Use a crimping tool to crimp the lug to the wire, see the following figure. Verify that the ground wire is securely attached to the grounding lug by attempting to pull the wire out of the crimped lug.

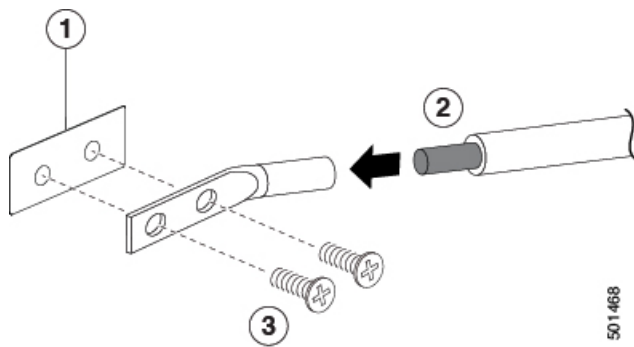

1	Chassis grounding pad	3	2 M4 screws are used to secure the grounding lug to the chassis
2	Grounding cable, with 0.75 in. (19 mm) of insulation that is stripped from one end, which is inserted into the grounding lug and crimped in place		

Step 3 Secure the grounding lug to the chassis grounding pad with two M4 screws, see the previous figure. Tighten the screws to 11 to 15 in-lb (1.24 to 1.69 N·m) of torque.

Step 4 Prepare the other end of the grounding wire and connect it to the facility ground.

Starting the Switch

You start the switch by connecting it to its dedicated power source. If you need $n+1$ redundancy, you must connect each of the power supplies to one or two power sources. If you need $n+n$ redundancy, you must connect each power supply in a switch to a different power source.



Note This equipment is designed to boot up in less than 30 minutes, dependent on its neighboring devices being fully up and running.

Before you begin

- The switch must be installed and secured to a rack or cabinet.
- The switch must be adequately grounded.
- The rack must be close enough to the dedicated power source so that you can connect the switch to the power source by using a designated power cables.
- You have the designated power cables for the power supplies that you are connecting to the dedicated power sources.



Note Depending on the outlet receptacle on your AC power distribution unit, you might need an optional jumper power cord to connect the switch to your outlet receptacle.

- The switch is not connected to the network (this includes any management or interface connections).
- The fan and power supply modules are fully secured in their chassis slots.

Step 1

For each AC power supply, do the following:

- a) Using the recommended AC power cable for your country or region, connect one end to the AC power supply.
- b) Connect the other end of the power cable to the AC power source.

Step 2

For each HVAC/HVDC power supply, connect it to a power source as follows:

- a) Using the recommended high voltage power cable for your country or region, connect the Anderson Power Saf-D-Grid connector on the power cable to the power receptacle on the power supply. Make sure that the connector clicks when fully pushed into the receptacle.
- b) Connect the other end of the power cable to a power source.
 - When connecting to an HVAC power source, insert the C14 or LS-25 plug in a receptacle for the HVAC power source.
 - When connecting to an HVDC power source, do the following:
 1. Verify that the power is turned off at a circuit breaker for the power source terminals.
 2. Remove the nuts from each of the terminal posts for the power supply.
 3. Place the power cable negative-wire terminal ring on the negative terminal for the power source and secure them with a terminal nut.
 4. Place the power cable positive-wire terminal ring on the positive terminal for the power source and secure them with a terminal nut.
 5. Place the power cable ground-wire terminal ring on the ground terminal for the power source and secure them with a terminal nut.
 6. If there is a safety cover for the power source terminals, place and secure it over the terminals to avoid an electrical shock hazard.
 7. Turn on the power at the power source circuit breaker.

Step 3

For each DC power supply, do the following:

- a) Turn off the circuit breaker for the power source to avoid an electrical shock hazard.
- b) Verify that the power cable wires from the power source are connected to a connector block.
- c) Insert the connector block into the receptacle on the power supply. Make sure that the connector block clicks when fully inserted in the receptacle and does not pull out.
- d) If there is a safety cover for the terminals, place and secure it over the terminals to avoid an electrical shock hazard.
- e) Turn on the power at the circuit breaker for the DC power source.

Step 4

Verify that the power supply LED is on and green.

Step 5

Listen for the fans; they should begin operating when the power supply is powered.

Step 6 After the switch boots, verify that the following LEDs are lit:

- On the fan modules, the Status (STA or STS) LED is green.

If a fan module Status LED is not green, try reinstalling the fan module.

- After initialization, the switch chassis Status (labeled as STA or STS) LED is green.

Step 7 Verify that the system software has booted and the switch has initialized without error messages.

A setup utility automatically launches the first time that you access the switch and guides you through the basic configuration. For instructions on how to configure the switch and check module connectivity, see the appropriate Cisco Nexus 9000 Series configuration guide.



CHAPTER 4

Connecting the Switch to the Network

- [Overview of Network Connections, on page 29](#)
- [Connecting a Console to the Switch, on page 30](#)
- [Creating the Initial Switch Configuration, on page 31](#)
- [Setting Up the Management Interface, on page 32](#)
- [Connecting Interface Ports to Other Devices, on page 33](#)
- [Uplink Connections, on page 33](#)
- [Downlink Connections, on page 33](#)

Overview of Network Connections

After you install the switch in a rack and power it up, you are ready to make the following network connections:

- **Console connection**—This is a direct local management connection that you use to initially configure the switch. You must make this connection first to initially configure the switch and determine its IP address, which is needed for the other connections.
- **Management connection**—After you complete the initial configuration using a console, you can make this connection to manage all future switch configurations.
- **Uplink and downlink interface connections**—These are connections to hosts and servers in the network.

Each of these connection types is explained in one of the sections that follow.



Note When running cables in overhead or subfloor cable trays, we strongly recommend that you locate power cables and other potential noise sources as far away as practical from network cabling that terminates on Cisco equipment. In situations where long parallel cable runs cannot be separated by at least 3.3 feet (1 meter), we recommend that you shield any potential noise sources by housing them in a grounded metallic conduit.



Note When using SFP+ or SFP transceivers in a QSFP+ or QSFP28 uplink port, install a QSFP-to-SFP adapter, such as the CVR-QSFP-SFP10G adapter, in the QSFP port and then install the SFP+ or SFP transceiver. The switch automatically sets the port speed to the speed of the installed transceiver.

Connecting a Console to the Switch

Before you create a network management connection for the switch or connect the switch to the network, you must create a local management connection through a console terminal. And then configure an IP address for the switch. You can use the console to perform the following functions, each of which can be performed through the management interface after you make that connection:

- Configure the switch using the command-line interface (CLI).
- Monitor network statistics and errors.
- Configure Simple Network Management Protocol (SNMP) agent parameters.
- Download software updates.

You make this local management connection between the asynchronous serial port on a supervisor module and a console device capable of asynchronous transmission. Typically, you can use a computer terminal as the console device. On the supervisor modules, you use the console serial port.



Note Before you can connect the console port to a computer terminal, make sure that the computer terminal supports VT100 terminal emulation. The terminal emulation software makes communication between the switch and computer possible during setup and configuration.

Before you begin

- The switch must be fully installed in its rack, which is connected to a power source, and grounded.
- The necessary cabling for the console, management, and network connections must be available.
 - An RJ-45 rollover cable provided in the switch accessory kit.
 - Network cabling is routed to the location of the installed switch.

Step 1 Configure the console device to match the following default port characteristics:

- 9600 baud
- 8 data bits
- 1 stop bit
- No parity

Step 2 Connect an RJ-45 rollover cable to the console port on the switch.

You can find this cable in the accessory kit.

Step 3 Route the RJ-45 rollover cable to the console or modem.

Step 4 Connect the other end of the RJ-45 rollover cable to the console or to a modem.

What to do next

You are ready to create the initial switch configuration (see [Creating the Initial Switch Configuration, on page 31](#)).

Creating the Initial Switch Configuration

You assign an IP address to the switch management interface so that you can then connect the switch to the network.

When you initially power up the switch, it boots up and asks you a series of questions to configure the switch. To connect the switch to the network, you can use the default choices for each configuration except the IP address, which you must provide. You can perform the other configurations later as described in the *Cisco Nexus 9000 Series NX-OS Fundamentals Configuration Guide*.



Note Know the unique name that is needed to identify the switch among the devices in the network.

Before you begin

- A console device must be connected with the switch.
- The switch must be connected to a power source.
- Determine the IP address and the netmask that is needed for the Management (Mgmt0) interface.

Step 1 Power up the switch by connecting each installed power supply to an AC circuit.

If you are using the combined or power-supply ($n+1$) power mode, connect all the power supplies to the same AC circuit. If you are using the input-source ($n+n$) power mode, connect half of the power supplies to one AC circuit. And connect the other half of the power supplies to another AC circuit.

The Input and Output LEDs on each power supply light up (green) when the power supply units are sending power to the switch, and the software asks you to specify a password to use with the switch.

Step 2 Enter a new password to use for this switch.

The software checks the security strength of your password and rejects your password if it is not considered to be a strong password. To increase the security strength of your password, make sure that it adheres to the following guidelines:

- At least eight characters
- Minimizes or avoids the use of consecutive characters (such as "abcd").
- Minimizes or avoids repeating characters (such as "aaabbb").
- Does not contain recognizable words from the dictionary.
- Does not contain proper names.
- Contains both uppercase and lowercase characters
- Contains numbers and letters

Examples of strong passwords include the following:

- If2CoM18
- 2004AsdfLkj30
- Cb1955S21

Note Clear text passwords cannot include the dollar sign (\$) special character.

Tip If a password is trivial (such as a short, easy-to-decipher password), the software will reject your password configuration. Be sure to configure a strong password as explained in this step. Passwords are case-sensitive.

If you enter a strong password, the software asks you to confirm the password.

Step 3 Enter the same password again.

If you enter the same password, the software accepts the password and begins asking a series of configuration questions.

Step 4 Until you are asked for an IP address, you can enter the default configuration for each question.

Repeat this step for each question until you are asked for the Mgmt0 IPv4 address.

Step 5 Enter the IP address for the management interface.

The software asks for the Mgmt0 IPv4 netmask.

Step 6 Enter a network mask for the management interface.

The software asks if you need to edit the configuration.

Step 7 Enter **no** not to edit the configuration.

The software asks if you need to save the configuration.

Step 8 Enter **yes** to save the configuration.

What to do next

You can now set up the management interface for each supervisor module on the switch.

Setting Up the Management Interface

The RJ-45 and/or SFP management ports provide out-of-band management, which enables you to use the command-line interface (CLI) to manage the switch by its IP address. You can use one of these ports depending on the cable and connectors that you are using to connect the management interface to the network.

Before you begin

- The switch must be powered on.
- The switch must be initially configured using a console.

-
- Step 1** Connect the management cable into the management port on the switch. For shorter connections, you can use a cable with RJ-45 connectors. For longer connections, you can use an optical cable with SFP transceivers (LH or SX type).
- Note** Use only one of these management ports—the switch does not support the use of both management ports.
- Step 2** Connect the other end of the cable to a 10/100/1000 or SFP port on a network device.
-

Connecting Interface Ports to Other Devices

After you perform the initial configuration for the switch and create a management connection, you are ready to connect the interface ports on the switch to other devices. Depending on the types of interface ports on the switch, you will need to use interface cables with QSFP28, QSFP+, SFP+, SFP transceivers, or RJ-45 connectors to connect the switch to other devices.



Note If you need to use SFP+ or SFP transceivers in a QSFP+ or QSFP28 uplink port, install a QSFP-to-SFP adapter, such as the CVR-QSFP-SFP10G adapter, in the QSFP port and then install the SFP+ or SFP transceiver. The switch automatically sets the port speed to the speed of the installed transceiver.

If the transceivers that you are using can be separated from their optical cables, install the transceivers without their cables before inserting the cables into the transceivers. This helps to prolong the life of both the transceiver and cables. When removing transceivers from the switch, it is best to remove the optical cable first and then remove the transceiver.

To determine which transceivers, adapters, and cables are supported by this switch, see the [Cisco Transceiver Modules Compatibility](#) Information document.

Uplink Connections

For a list of transceivers and cables used by this switch for uplink connections, see <http://www.cisco.com/c/en/us/support/interfaces-modules/transceiver-modules/products-device-support-tables-list.html>.



Warning **Statement 1051**—Laser Radiation

Invisible laser radiation may be emitted from disconnected fibers or connectors. Do not stare into beams or view directly with optical instruments.

Downlink Connections

For a listing of the transceivers and cables that the optical downlink ports support, see <http://www.cisco.com/c/en/us/support/interfaces-modules/transceiver-modules/products-device-support-tables-list.html>



CHAPTER 5

Replacing Components

- [Replacing a Fan Module During Operations, on page 35](#)
- [Replacing a Power Supply Module, on page 36](#)

Replacing a Fan Module During Operations

All fan and power supply modules must have the same airflow direction or else an error can occur with the switch overheating and shutting down. You can determine the airflow direction of a fan module by the color of the stripe on the front of the module. If the fan module has a blue stripe for port-side exhaust airflow, the power supplies must have blue coloring for the same airflow direction. If the fan module has a burgundy stripe for port-side intake airflow, the power supplies must have burgundy coloring for the same airflow direction. To avoid over heating the switch, make sure that the fan modules are positioned in one of the following ways:

- For port-side exhaust airflow with blue coloring, position the fan modules in a cold aisle.
- For port-side intake airflow with burgundy coloring, position the ports in a cold aisle.

Before you begin

Before you can replace a fan module, ensure that the following conditions exist:

- The replacement fan module must have the same airflow direction as the other modules in the chassis.

If you must replace the fan module during operations and the above conditions are not met, leave the fan module that you need to replace in the chassis to preserve the designed airflow until you have the required module.

Step 1 Remove the fan module that you need to replace as follows:

- a) Place the removed module on an antistatic surface or in an antistatic bag. If possible, repack the module in its packing materials for safe shipping or storage.

Step 2 Follow these steps to replace the missing fan module within two minutes to avoid a shutdown.

- a) Remove the replacement fan module from its packing materials and place it on an antistatic surface.

Hold the module by its handle and do not touch the electrical connectors on its backside. Also, to protect the electrical connectors, avoid letting them come in contact with anything other than the electrical connectors inside the chassis.

- b) Position the fan module in front of the open fan slot (be sure that the backside of the module with the electrical connectors is positioned to enter the slot first) and slide the module all the way into the chassis until its front side comes in contact with the chassis. For the last 0.2 inches (0.5 cm), carefully mount the module onto the chassis connectors by pushing more firmly, but do not force the module if it does not move further (excessive force can damage the connectors).

Note If you are not able to push the module all the way into the slot, carefully slide the module out of the slot and check its electrical connectors for damage. If damaged, contact Cisco Technical Assistance for help. If undamaged, repeat this step to reinstall the module.

- c) Verify that the STS LED turns on and becomes green.

If the STS LED does not turn on, slide the module out of the chassis, and visually check the electrical connectors on the back side of the chassis for damage. If damaged, contact Cisco Technical Assistance for help. If undamaged, repeat the previous step to reinstall the module.

Replacing a Power Supply Module

The switch requires two power supplies for redundancy. With one power supply providing the necessary power for operations, you can replace the other power supply during operations so long as the new power supply has the same airflow direction as the other modules in the chassis.

You can replace a power supply with another supported power supply that has the same power source type as the other installed power supply. Additionally, the airflow direction of the power supply must match or conform to the airflow direction of the installed fan modules. For the airflow direction used by the switch, see the coloring of the fan modules.

Removing an AC Power Supply

To remove an AC power supply, you must first disconnect the power cable and then remove the module from the chassis.

Before you begin

- To replace a power supply during operations, you must have a functioning power supply providing power to the switch while you replace the other power supply. If there is only one power supply installed in the switch and you need to replace it, install the new power supply in the open slot and power it up before removing the original power supply.
- Ensure that the chassis is grounded. For grounding instructions, see [Grounding the Chassis, on page 25](#).

Step 1 Pull the power cord out from the power receptacle on the power supply to be removed and verify that the LED turns off.

Note The LED might be on and amber colored to indicate that the input power has been disconnected.

Step 2 Remove the power supply from the chassis by pushing and holding its thumb latch to the left and pulling the power supply part way out of the chassis.

- Step 3** Place your other hand under the power supply to support it while you slide it out of the chassis.
Either place the power supply on an antistatic surface or pack it in its packing materials.
- Step 4** If the power supply slot is to remain empty, install a blank power supply filler panel (part number N2200-P-BLNK).
-

What to do next

You are ready to install the replacement power supply.

Removing an HVAC/HVDC Power Supply

You can remove one power supply while the other one provides power to the switch.

To disconnect the power supply from its power cables, you must shut off the power from the power source and then disconnect the connector for the power cables.

- Step 1** Turn off the circuit breaker for the power feed to the power supply that you are replacing.
Be sure that the LEDs turn off on the power supply that you are removing.
- Step 2** Remove the power cable from the power supply by pressing the tab on the top of the Anderson Power SAF-D-Grid connector and pull the cable and connector out of the power supply.
- Step 3** Grasp the power supply handle while pressing the release latch towards the power supply handle.
- Step 4** Place your other hand under the power supply to support it while you slide it out of the chassis.
- Caution** Do not touch the electrical connectors on the back side of the module and prevent anything else from coming into contact with and damaging the connectors.
-

What to do next

You are ready to install an HVAC/HVDC power supply in the open slot.

Removing a DC Power Supply

You can remove one power supply while the other one provides power to the switch.

To disconnect the power supply from its power cables, you must shut off the power from the power source and then disconnect the connector for the power cables.

- Step 1** Turn off the circuit breaker for the power feed to the power supply that you are replacing.
Be sure that the LEDs turn off on the power supply that you are removing.
- Step 2** Remove the power cable from the power supply by doing the following:
- Step 3** Grasp the power supply handle while pressing the release latch towards the power supply handle.

Step 4 Pull the power supply out of the bay.

What to do next

You are ready to install a DC power supply in the open slot.

Installing an AC Power Supply

You can replace one power supply while the other one provides power to the switch.

Before you begin

- The power supply that you are installing must be capable of using the same airflow direction as the fan trays installed in the same switch and it must use the same type of power source as the other power supply installed in the same switch (do not mix AC and DC power supplies in the same switch).



Note If the power supply that you are replacing has a different color handle than the replacement power supply, verify that it has or will have the same airflow direction as the other modules in the switch.

- An AC power source must be within reach of the power cable that will be used with the replacement power supply. If you are using $n+n$ power redundancy, there must be a separate power source for each power supply installed in the chassis. Otherwise, only one power source is required.
- There must be an earth ground connection to the chassis that you are installing the replacement module. Typically, the chassis is grounded by its metal-to-metal connection with a grounded rack. If you need to ground the chassis, see [Grounding the Chassis, on page 25](#).

Step 1 Holding the replacement power supply with one hand underneath the module and the other hand holding the handle, turn the power supply so that its release latch is on the side and align the back end of the power supply (the end with the electrical connections) to the open power supply slot before carefully sliding the power supply all the way into the slot until it clicks into place.

Note If the power supply does not fit into the open slot, turn the module over before sliding it carefully into the open slot.

Step 2 Test the installation by trying to pull the power supply out of the slot without using the release latch.

If the power supply does not move out of place, it is secured in the slot. If the power supply moves, carefully press it all the way into the slot until it clicks in place.

Step 3 Attach the power cable to the electrical outlet on the front of the power supply.

Step 4 Make sure that the other end of the power cable is attached to the appropriate power source for the power supply.

Note Depending on the outlet receptacle on your power distribution unit, you might need the optional jumper cable to connect the switch to your outlet receptacle.

Step 5 Verify that the power supply is operational by making sure that the power supply LED is green.

Installing an HVAC/HVDC Power Supply

You can replace one power supply while the other one provides power to the switch.



Note If the power supply that you are replacing has a different color handle than the replacement power supply, verify that it has or will have the same airflow direction as the other modules in the switch.

Before you begin

- If you are using DC power for the replacement power supply, the circuit breaker for the power feed to the power supply that you are replacing must be turned off.
 - If you are using $n+n$ power redundancy, there must be a separate power source for each power supply installed in the chassis (power sources must be of the same type—do not mix AC and DC power sources for the same switch). Otherwise, only one power source is required.
 - There must be an earth ground connection to the chassis that you are installing the replacement module. Typically, the chassis is grounded by its metal-to-metal connection to a grounded rack. If you need to ground this chassis by another means, see [Grounding the Chassis, on page 25](#).
-

Step 1 Holding the replacement power supply with one hand underneath the module and the other hand holding the handle, turn the power supply so that its release latch is on the side and align the back end of the power supply (the end with the electrical connections) to the open power supply slot before carefully sliding the power supply all the way into the slot until it clicks into place.

Note If the power supply does not fit into the open slot, turn the module over before sliding it into the open slot.

Step 2 Test the installation by trying to pull the power supply out of the slot without using the release latch.

If the power supply does not move out of place, it is secured in the slot. If the power supply moves, carefully press it all the way into the slot until it clicks in place.

Step 3 If the DC power cables and a grounding cable are already connected to an electrical connector block, insert the block into the power receptacle on the power supply.

Step 4 Make sure that the other end of the power cable is connected to the appropriate power source for the power supply.

Step 5 If using a DC power source, turn on the circuit breaker for the DC power source connected to the power supply.

Step 6 Verify that the power supply is operational by making sure that the power supply LED is green.

Installing a DC Power Supply

You can replace one power supply while the other one provides power to the switch.

Before you begin

- The circuit breaker for the DC power source for the power supply must be turned off.
- The power supply that you are installing must be capable of using the same airflow direction as the fan trays installed in the same switch
- A DC power source must be within reach of the power cable that will be used with the replacement power supply. If you are using $n+n$ power redundancy, there must be a separate power source for each power supply installed in the chassis (do not mix AC and DC power sources for the same switch). Otherwise, only one power source is required.
- There must be an earth ground connection to the chassis that you are installing the replacement module. Typically, the chassis is grounded by its metal-to-metal connection to a grounded rack. If you need to ground this chassis by another means, see [Grounding the Chassis, on page 25](#).
- We recommend 8-AWG wire for DC installation in the U.S.
- All DC power supplies have reverse polarity protection. When you inadvertently connect the input power (+) to the DC PSU's – terminal and the input power – to the DC PSU's (+) terminal, the PSU will not be damaged and will operate fine after the input power feeds are correctly wired.

Step 1 Holding the replacement power supply with one hand underneath the module and the other hand holding the handle, turn the power supply so that its release latch is on the side and align the back end of the power supply (the end with the electrical connections) to the open power supply slot before carefully sliding the power supply all the way into the slot until it clicks into place.

Note If the power supply does not fit into the open slot, turn the module over before carefully sliding it into the open slot.

Step 2 If the DC power cables and a grounding cable are already connected to an electrical connector block, insert the block into the power receptacle on the power supply.

Step 3 Turn on the circuit breaker for the DC power source connected to the power supply.

Step 4 Verify that the power supply is operational by making sure that the power supply LED is green.



APPENDIX **A**

Rack Specifications

- [Overview of Racks, on page 41](#)
- [General Requirements for Cabinets and Racks, on page 41](#)
- [Requirements Specific to Standard Open Racks, on page 42](#)
- [Requirements Specific to Perforated Cabinets, on page 42](#)
- [Cable Management Guidelines, on page 42](#)

Overview of Racks

You can install the switch in the following types of cabinets and racks, assuming an external ambient air temperature range of 0 to 104°F (0 to 40°C):

- Standard perforated cabinets
- Solid-walled cabinets with a roof fan tray (bottom to top cooling)
- Standard open racks



Note If you are selecting an enclosed cabinet, we recommend one of the thermally validated types, either standard perforated or solid-walled with a fan tray.



Note We do not recommend that you use racks that have obstructions (such as power strips), because the obstructions could impair access to field-replaceable units (FRUs).

General Requirements for Cabinets and Racks

The cabinet or rack must also meet the following requirements:

- Standard 19-inch (48.3 cm) (two- or four-post EIA cabinet or rack, with mounting rails that conform to English universal hole spacing per section 1 of ANSI/EIA-310-D-1992). For more information, see [Requirements Specific to Perforated Cabinets, on page 42](#).

- The minimum vertical rack space requirement per chassis is:
 - For a one RU (rack unit) switch, 1.75 inches (4.4 cm)
 - For a one and a half RU (rack unit) switch, 2.63 (6.68 cm)
 - For a two RU (rack unit) switch, 3.5 inches (8.8 cm)
 - For a three RU (rack unit) switch, 5.25 inches (13.3 cm)
- The width between the rack-mounting rails must be at least 17.75 inches (45.0 cm) if the rear of the device is not attached to the rack. For four-post EIA racks, this measurement is the distance between the two front rails.

Four-post EIA cabinets (perforated or solid-walled) must meet the following requirements:

- The minimum spacing for the bend radius for fiber-optic cables should have the front-mounting rails of the cabinet offset from the front door by a minimum of 3 inches (7.6 cm).
- The distance between the outside face of the front mounting rail and the outside face of the back mounting rail should be 23.0 to 30.0 inches (58.4 to 76.2 cm) to allow for rear-bracket installation.

Requirements Specific to Standard Open Racks

If you are mounting the chassis in an open rack (no side panels or doors), ensure that the rack meets the following requirements:

- The minimum vertical rack space per chassis must be equal to the rack unit (RU) of the chassis. One rack unit is equal to 1.75 inches (4.4 cm).
- The distance between the chassis air vents and any walls should be 2.5 inches (6.4 cm).

Requirements Specific to Perforated Cabinets

A perforated cabinet has perforations in its front and rear doors and side walls. Perforated cabinets must meet the following requirements:

- The front and rear doors must have at least a 60 percent open area perforation pattern, with at least 15 square inches (96.8 square cm) of open area per rack unit of door height.
- The roof should be perforated with at least a 20 percent open area.
- The cabinet floor should be open or perforated to enhance cooling.

The Cisco R Series rack conforms to these requirements.

Cable Management Guidelines

To help with cable management, you might want to allow additional space in the rack above and below the chassis to make it easier to route all of the fiber optic or copper cables through the rack.



APPENDIX **B**

System Specifications

- [Environmental Specifications, on page 43](#)
- [Switch Dimensions, on page 43](#)
- [Switch and Module Weights and Quantities, on page 44](#)
- [Transceiver and Cable Specifications, on page 44](#)
- [Switch Power Input Requirements, on page 44](#)
- [Power Specifications, on page 45](#)
- [Power Cable Specifications, on page 46](#)
- [Regulatory Standards Compliance Specifications, on page 49](#)

Environmental Specifications

Environment		Specification
Temperature	Ambient operating temperature	32 to 104°F (0 to 40°C)
	Ambient nonoperating	−40 to 158°F (−40 to 70°C)
Relative humidity	Nonoperating	5 to 95%
	Operating	5 to 90%
Altitude	Operating	0 to 13,123 feet (0 to 4,000 meters)

Switch Dimensions

Switch	Width	Depth	Height
Cisco Nexus 93360YC-FX2	17.4 inches (44.2 cm)	24.14 inches (61.31 cm)	3.38 inches (8.59 cm) (2 RU)

Switch and Module Weights and Quantities

Component	Weight per Unit	Quantity
Cisco Nexus 93360YC-FX2 Chassis (N9K-C93360YC-FX2)	27.4 lb (12.4 kg)	1
Fan Module	—	3
– Port-side exhaust (blue) (NXA-FAN-160CFM-PE)	1.3 lb (0.59 kg)	
– Port-side intake (burgundy) (NXA-FAN-160CFM-PI)		
Power Supply module	—	2 (1 for operations and 1 for redundancy)
– 1200-W AC port-side exhaust (blue) (NXA-PAC-1200W-PE)	2.64 lb (1.2 kg)	
– 1200-W AC port-side intake (burgundy) (NXA-PAC-1200W-PI)		
– 1200-W HVAC/HVDC dual-direction (white) (N9K-PUV-1200W)		
– 930-W DC port-side exhaust (blue) (NXA-PDC-930W-PE)		
– 930-W DC port-side intake (burgundy) (NXA-PDC-930W-PI)		

Transceiver and Cable Specifications

To determine which transceivers, adapters, and cables are supported by this switch, see <https://www.cisco.com/c/en/us/support/interfaces-modules/transceiver-modules/products-device-support-tables-list.html>.

To see the transceiver specifications and installation information, see <https://www.cisco.com/c/en/us/support/interfaces-modules/transceiver-modules/products-device-support-tables-list.html>.

Switch Power Input Requirements

The following table lists the typical amount of power that the switch consumes. It also lists the maximum amount of power that you must provision for the switch and power supply for peak conditions.



Note Some power supplies have capabilities that are greater than the maximum power requirements for a switch. To determine the power consumption characteristics for the switch, use the typical and maximum requirements that are listed in the following table.

Switch	Typical Power Consumption (AC or DC)	Maximum Power Consumption (AC or DC)	Heat Dissipation Requirement
Cisco Nexus 93360YC-FX2	404 W	900 W	3070.928 BTU per hour

Power Specifications

Power specifications include the specifications for each type of power supply module.

1200-W AC Power Supply Specifications

These specifications apply to the following 1200-W AC power supplies:

Characteristic	Specification
AC input voltage	Nominal range: 100-120 VAC, 200-240 VAC
AC input frequency	Nominal range: 50 to 60 Hz (Range: 47-63 Hz)
Maximum AC input current	10 A at 100-120 VAC 8 A at 200-240 VAC
Maximum output power per power supply	800 W at 100-120 VAC 1200 W at 200-240 VAC
Maximum hold-up time	12 ms at 650 W
Power supply output voltage	12 VDC
Power supply standby voltage	12 VDC
Efficiency rating	Climate Savers Platinum Efficiency (80Plus Platinum certified)
Form factor	RSP1

1200-W HVAC/HVDC Power Supply Specifications

These specifications apply to the 1200-W HVAC/HVDC (N9K-PUV-1200W) power supplies.

Characteristic	Specification
Input voltage <ul style="list-style-type: none"> • AC (for 1230 W output) • DC (for 1230 W output) 	Nominal (Range) <ul style="list-style-type: none"> • 200 to 277 VAC
AC input frequency	Nominal: 50 to 60 Hz (Range: 47-63 Hz)
Maximum AC input current	100 VAC, 10A
Maximum inrush current	35 A (cold turn on); 70 A (hot turn on)

Characteristic	Specification
Maximum output Watts <ul style="list-style-type: none"> • For 200 to 277 VAC • For 192 to 400 VDC 	Per power supply <ul style="list-style-type: none"> • 1230 W • 1230 W
Power supply output voltage <ul style="list-style-type: none"> • For 200 to 277 VAC • For 192 to 400 VDC 	Per power supply <ul style="list-style-type: none"> • 12 VDC at 100 A • 12 VDC at 100 A
Power supply standby voltage	12 V at 2.5 A
Efficiency rating	Climate Savers Platinum Efficiency (80Plus Platinum certified)
Form factor	RSP1

930-W DC Power Supply Specifications

These specifications apply to the following power supplies:

- NXA-PDC-930W-PE
- NXA-PDC-930W-PI

Characteristic	Specification
DC input voltage range	Nominal range: -48 to -60 VDC nominal (Range: -40 to -60 VDC)
Maximum DC input current	23 A at -48 VDC
Maximum output power per power supply	930 W
Maximum inrush current	35 A (sub-cycle duration)
Maximum hold-up time	8 ms at 930 W
Power supply output voltage	12 VDC
Power supply standby voltage	12 VDC
Efficiency rating	Greater than 92% at 50% load
Form factor	RSP1

Power Cable Specifications

The following sections specify the power cables that you can order and use with this switch.

Power Cable Specifications for AC Power Supplies

Power Type	Power Cord Part Number	Cord Set Description
	CAB-C13-C14-2M	Power Cord Jumper, C13-C14 Connectors, 6.6 feet (2.0 m)
	CAB-C13-CBN	Cabinet jumper power cord, 250 VAC, 10 A, C14-C13 connectors, 2.3 feet (0.7 m)
Argentina	CAB-250V-10A-AR	250 V, 10 A, 8.2 feet (2.5 m)
Australia	CAB-9K10A-AU	250 VAC, 10 A, 3112 plug, 8.2 feet (2.5 m)
Brazil	CAB-250V-10A-BR	250 V, 10 A, 6.9 feet (2.1 m)
European Union	CAB-9K10A-EU	250 VAC, 10 A, CEE 7/7 plug, 8.2 feet (2.5 m)
India	CAB-IND-10A	10 A, 8.2 feet (2.5 m)
India	CAB-C13-C14-2M-IN	Power Cord Jumper, C13-C14 Connectors, 6.6 feet (2.0 m)
India	CAB-C13-C14-3M-IN	Power Cord Jumper, C13-C14 Connectors, 9.8 feet (3.0 m)
Israel	CAB-250V-10A-IS	250 V, 10 A, 8.2 feet (2.5 m)
Italy	CAB-9K10A-IT	250 VAC, 10 A, CEI 23-16/VII plug, 8.2 feet (2.5 m)
Japan	CAB-C13-C14-2M-JP	Power Cord Jumper, C13-C14 Connectors, 6.6 feet (2.0 m)
North America	CAB-9K12A-NA	125 VAC, 13 A, NEMA 5-15 plug, 8.2 feet (2.5 m)
North America	CAB-AC-L620-C13	NEMA L6-20-C13, 6.6 feet (2.0 m)
North America	CAB-N5K6A-NA	200/240V, 6A, 8.2 feet (2.5 m)
Peoples Republic of China	CAB-250V-10A-CN	250 V, 10 A, 8.2 feet (2.5 m)
South Africa	CAB-250V-10A-ID	250 V, 10 A, 8.2 feet (2.5 m)
Switzerland	CAB-9K10A-SW	250 VAC, 10 A, MP232 plug, 8.2 feet (2.5 m)
United Kingdom	CAB-9K10A-UK	250 VAC, 10 A, BS1363 plug (13 A fuse), 8.2 (2.5 m)
All except Argentina, Brazil, and Japan	NO-POWER-CORD	No power cord included with switch

HVAC/HVDC Power Cables Supported by ACI-Mode and NX-OS Mode Switches





Part Number	Cord Set Description	Photo
CAB-HVAC-SD-0.6M	HVAC 2-foot (0.6 m) cable with Saf-D-Grid and SD connectors 277V AC	
CAB-HVAC-C14-2M	HVAC 6.6-foot (2.0 m) cable with Saf-D-Grid and C14 (use for up to 240 V) connector 250V AC	
CAB-HVAC-RT-0.6M	HVAC 2-foot (0.6 m) cable with Saf-D-Grid and RT connector 277V AC	
CAB-HVDC-3T-2M	HVDC 6.6-foot (2.0 m) cable with Saf-D-Grid and three terminal connectors 300V AC / 400V DC (+200/-200 V DC)	
NO-POWER-CORD	All except Argentina, Brazil, and Japan No power cord included with switch	Not applicable

Table 1: HVAC/HVDC Power Cables Callout Table

1	Connect this end to the power supply unit.
---	--

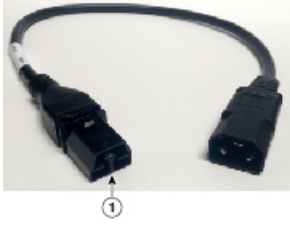
DC Power Cable Specifications

Part Number	Description	Photo
NXA-PDC-930W-PE/PI	The 930W DC power supply (NXA-PDC-930W-PE/PI) is shipped with cable CAB-48DC-40A-8AWG.	

Regulatory Standards Compliance Specifications

The following table lists the regulatory standards compliance for the switch.

Table 2: Regulatory Standards Compliance: Safety and EMC

Specification	Description
Regulatory compliance	Products should comply with CE Markings according to directives 2004/108/EC and 2006/95/EC.
Safety	<ul style="list-style-type: none"> • CAN/CSA-C22.2 No. 60950-1 Second Edition • CAN/CSA-C22.2 No. 62368-1-19 Third Edition • NRTL 60950-1 Second Edition • IEC 62368-1 • EN 62368-1 • AS/NZS 62368-1 • GB4943 • UL 62368-1

Specification	Description
EMC: Emissions	<ul style="list-style-type: none">• 47CFR Part 15 (CFR 47) Class A• AS/NZS CISPR22 Class A• CISPR22 Class A• EN55022 Class A• ICES003 Class A• VCCI Class A• EN61000-3-2• EN61000-3-3• KN22 Class A• CNS13438 Class A
EMC: Immunity	<ul style="list-style-type: none">• EN55024• CISPR24• EN300386• KN 61000-4 series
RoHS	The product is RoH-6 compliant with exceptions for leaded-ball grid-array (BGA) balls and lead press-fit connectors.



APPENDIX C

LEDs

- [Switch Chassis LEDs, on page 51](#)
- [Fan Module LEDs, on page 52](#)
- [Power Supply LEDs, on page 52](#)

Switch Chassis LEDs

The BCN, STS, and ENV, LEDs are located on the left side of the front of the switch. The port LEDs appear as triangles pointing up or down to the nearest port.

LED	Color	Status
BCN	Flashing blue	The operator has activated this LED to identify this switch in the chassis.
	Off	This switch is not being identified.
STS	Green	The switch is operational.
	Flashing amber	The switch is booting up.
	Amber	Temperature exceeds the minor alarm threshold.
	Red	Temperature exceeds the major alarm threshold.
	Off	The switch is not receiving power.
ENV	Green	Fans and power supply modules are operational.
	Amber	At least one fan or power supply module is not operating.
(port)	Green	Port admin state is 'Enabled', SFP is present and the interface is connected (that is, cabled, and the link is up).
	Amber	Port admin state is 'Disabled, or the SFP is absent, or both.
	Off	Port admin state is 'Enabled' and SFP is present, but interface is not connected.

Fan Module LEDs

The fan module LED is located below the air holes on the front of the module.

LED	Color	Status
STS	Green	The fan module is operational.
	Red	The fan module is not operational (fan is probably not functional).
	Off	Fan module is not receiving power.

Power Supply LEDs

The power supply LEDs are located on the left right portion of the power supply. Combinations of states indicated by the Okay and Fault LEDs indicate the status for the module as shown in the following table.

OK LED	FAIL or FAIL/ID LED	Status
Green	Off	Power supply is on and outputting power to the switch.
Flashing green	Off	Power supply is connected to an AC power source but not outputting power to the switch. The power supply may not be properly installed in the chassis.
Off	Off	Either all the installed power supplies are not receiving power or an uninstalled power supply is not receiving power.
Off	Flashing amber	Power supply is operating but a warning condition has occurred—possibly one of the following conditions: <ul style="list-style-type: none"> • High temperature • High power • Slow power supply fan • Low voltage • Power supply is installed in the chassis but was disconnected from the power source.
Off	Flashing amber (10 seconds) then amber	Power supply is installed without a connection to a power source.

OK LED	FAIL or FAIL/ID LED	Status
Off	Amber	Power supply failure—possibly one of the following conditions: <ul data-bbox="776 373 1055 556" style="list-style-type: none">• Over voltage• Over current• Over temperature• Power supply fan failure



APPENDIX D

Additional Kits

- [Rack Mount Kit N9K-C9300-RMK](#), on page 55
- [Vent Bracket](#), on page 55

Rack Mount Kit N9K-C9300-RMK

The following table lists and illustrates the contents for the 2-RU rack-mount kit (N9K-C9300-RMK).

Illustration	Description	Quantity
	Rack-mount kit <ul style="list-style-type: none"> • Bottom support rails (2) • Front-mount brackets (2) 	1

Vent Bracket

The following table lists and illustrates the vent bracket (NXA-ACC-BAV4).



Note You require the vent bracket (NXA-ACC-BAV4) for NEBS (Network Equipment-Building System) compliance only.

Illustration	Description	Quantity
	Vent bracket	1

