



## **Cisco VSG for Microsoft Hyper-V, Release 5.2(1)VSG2(1.1a) and Cisco Prime NSC, Release 3.2 Installation and Upgrade Guide**

**First Published:** July 15, 2013

**Last Modified:** February 28, 2014

### **Americas Headquarters**

Cisco Systems, Inc.  
170 West Tasman Drive  
San Jose, CA 95134-1706  
USA  
<http://www.cisco.com>  
Tel: 408 526-4000  
800 553-NETS (6387)  
Fax: 408 527-0883

Text Part Number: OL-31174-01

THE SPECIFICATIONS AND INFORMATION REGARDING THE PRODUCTS IN THIS MANUAL ARE SUBJECT TO CHANGE WITHOUT NOTICE. ALL STATEMENTS, INFORMATION, AND RECOMMENDATIONS IN THIS MANUAL ARE BELIEVED TO BE ACCURATE BUT ARE PRESENTED WITHOUT WARRANTY OF ANY KIND, EXPRESS OR IMPLIED. USERS MUST TAKE FULL RESPONSIBILITY FOR THEIR APPLICATION OF ANY PRODUCTS.

THE SOFTWARE LICENSE AND LIMITED WARRANTY FOR THE ACCOMPANYING PRODUCT ARE SET FORTH IN THE INFORMATION PACKET THAT SHIPPED WITH THE PRODUCT AND ARE INCORPORATED HEREIN BY THIS REFERENCE. IF YOU ARE UNABLE TO LOCATE THE SOFTWARE LICENSE OR LIMITED WARRANTY, CONTACT YOUR CISCO REPRESENTATIVE FOR A COPY.

The Cisco implementation of TCP header compression is an adaptation of a program developed by the University of California, Berkeley (UCB) as part of UCB's public domain version of the UNIX operating system. All rights reserved. Copyright © 1981, Regents of the University of California.

NOTWITHSTANDING ANY OTHER WARRANTY HEREIN, ALL DOCUMENT FILES AND SOFTWARE OF THESE SUPPLIERS ARE PROVIDED "AS IS" WITH ALL FAULTS. CISCO AND THE ABOVE-NAMED SUPPLIERS DISCLAIM ALL WARRANTIES, EXPRESSED OR IMPLIED, INCLUDING, WITHOUT LIMITATION, THOSE OF MERCHANTABILITY, FITNESS FOR A PARTICULAR PURPOSE AND NONINFRINGEMENT OR ARISING FROM A COURSE OF DEALING, USAGE, OR TRADE PRACTICE.

IN NO EVENT SHALL CISCO OR ITS SUPPLIERS BE LIABLE FOR ANY INDIRECT, SPECIAL, CONSEQUENTIAL, OR INCIDENTAL DAMAGES, INCLUDING, WITHOUT LIMITATION, LOST PROFITS OR LOSS OR DAMAGE TO DATA ARISING OUT OF THE USE OR INABILITY TO USE THIS MANUAL, EVEN IF CISCO OR ITS SUPPLIERS HAVE BEEN ADVISED OF THE POSSIBILITY OF SUCH DAMAGES.

Any Internet Protocol (IP) addresses and phone numbers used in this document are not intended to be actual addresses and phone numbers. Any examples, command display output, network topology diagrams, and other figures included in the document are shown for illustrative purposes only. Any use of actual IP addresses or phone numbers in illustrative content is unintentional and coincidental.

Cisco and the Cisco logo are trademarks or registered trademarks of Cisco and/or its affiliates in the U.S. and other countries. To view a list of Cisco trademarks, go to this URL: <http://www.cisco.com/go/trademarks>. Third-party trademarks mentioned are the property of their respective owners. The use of the word partner does not imply a partnership relationship between Cisco and any other company. (1110R)

© 2014 Cisco Systems, Inc. All rights reserved.



## CONTENTS

---

### Preface

#### Preface vii

Audience vii

Document Conventions vii

Related Documentation for Cisco Virtual Security Gateway for Microsoft Hyper-V viii

Documentation Feedback ix

Obtaining Documentation and Submitting a Service Request ix

---

### CHAPTER 1

#### Overview 1

Information About Installing Cisco Prime NSC and Cisco VSG 1

Information About Cisco VSG 1

Cisco Prime NSC and VSG Architecture 2

Trusted Multitenant Access 4

Dynamic Virtualization-Aware Operation 5

Setting Up Cisco VSG and VLAN 6

Information About Cisco Prime NSC 7

Cisco Prime NSC Key Benefits 7

Cisco Prime NSC Components 8

Cisco Prime NSC Architecture 8

Cisco Prime NSC Security 9

Cisco Prime NSC API 9

Cisco Prime NSC and VSG 9

System Requirements 9

---

### CHAPTER 2

#### Installing the Cisco Prime NSC and Cisco VSG-Quick Start 11

Information About Installing Cisco Prime NSC and Cisco VSG 11

Cisco VSG and Cisco Prime NSC Installation Planning Checklists 12

Basic Hardware and Software Requirements 12

License Requirements	13
VLAN Configuration Requirements for VSG	14
Required Cisco Prime NSC and Cisco VSG Information	14
Tasks and Prerequisites Checklist	16
Host Requirements	19
Obtaining Cisco Prime NSC and Cisco VSG Software	19
Task 1: Installing the Cisco Prime NSC from an ISO Image	19
Task 2: On the VSM, Configuring Cisco Prime NSC Policy Agent	22
Task 3: On the VSM, Preparing Cisco VSG Port Profiles	24
Task 4: On the VSM, Configuring Virtual Network Adapters on the Hosts	26
Create Port-profile for the Virtual Network Adapter	26
Creating Virtual Network Adapter	27
Task 5: Installing Cisco VSG from an ISO Image	27
Task 6: On the VSG, Configuring the Cisco Prime NSC Policy Agent	31
Task 7: On Cisco VSG, Cisco VSM, and Cisco Prime NSC, Verifying the NSC Policy-Agent Status	32
Task 8: On Cisco Prime NSC, Configuring a Tenant, Security Profile, Compute Firewall, and Assigning Cisco VSG to the Compute Firewall	33
Configuring a Tenant on Cisco Prime NSC	34
Configuring a Security Profile on the Cisco Prime NSC	34
Configuring a Compute Firewall and Assigning Cisco VSG to Cisco Prime NSC	35
Task 9: On the Prime NSC, Configuring a Permit-All Rule	36
Task 10: On Cisco VSG, Verifying the Permit-All Rule	36
Task 11: Enabling Logging	37
Enabling Logging level 6 for Policy-Engine Logging	37
Enabling Global Policy-Engine Logging	38
Task 12: Enabling the Traffic VM Port-Profile for Firewall Protection and Verifying the Communication Between the VSM, VEM, and VSG	38
Enabling Traffic VM Port-Profile for Firewall Protection	39
Verifying the VSM or VEM for Cisco VSG Reachability	40
Checking the VM Virtual Ethernet Port for Firewall Protection	41
Task 13: Installing Microsoft Service Provider Foundation	41
Installing Service Provider Foundation	41
Configuring Service Provider Foundation	42
Verifying Service Provider Foundation Installation	42

Creating VM Manager on Cisco Prime NSC	42
Task 14: Sending Traffic Flow and on Cisco VSG Verifying Statistics and Logs	43
Sending Traffic Flow	44
Verifying Policy-Engine Statistics and Logs on Cisco VSG	45

---

**CHAPTER 3****Installing the Cisco Prime Network Services Controller 47**

Information About the Cisco Prime NSC	47
Installation Requirements	47
Cisco Prime NSC System Requirements	47
Web-Based GUI Client Requirements	48
Firewall Ports Requiring Access	49
Cisco Nexus 1000V Series Switch Requirements	49
Information Required for Installation and Configuration	50
Shared Secret Password Criteria	51
Microsoft Hyper-V Server Requirement	52
Installing Cisco Prime NSC	52

---

**CHAPTER 4****Installing the Cisco VSG 55**

Information About the Cisco VSG	55
Host and VM Requirements	55
Cisco VSG and Supported Cisco Nexus 1000V Series Device Terminology	56
Prerequisites for Installing the Cisco VSG Software	57
Obtaining the Cisco VSG Software	57
Installing the Cisco VSG Software	57
Installing the Cisco VSG Software from an ISO File	57
Configuring Initial Settings	60
On the VSG, Configuring the Cisco Prime NSC Policy Agent	61
Configuring Initial Settings on a Secondary Cisco VSG	63
Verifying the Cisco VSG Configuration	63
Where to Go Next	63

---

**CHAPTER 5****Registering Devices with the Cisco Prime NSC 65**

Registering a Cisco VSG	65
Registering Cisco Nexus 1000V VSM	66

**CHAPTER 6****Installing the Cisco VSG on a Cisco Cloud Service Platform Virtual Services Appliance 69**

Information About Installing the Cisco VSG on the Cisco Cloud Service Platform 69

Prerequisites for Installing Cisco VSG on the Cisco Cloud Service Platform 70

Guidelines and Limitations 70

Installing Cisco VSG on a Cisco Cloud Service Platform 71

**CHAPTER 7****Upgrading the Cisco VSG and the Cisco Prime NSC 77**

Complete Upgrade Procedure 77

Information About Cisco Prime NSC Upgrades 78

Information About Cisco VSG Upgrades 78

Upgrade Guidelines and Limitations 78

Upgrade Procedure for Cisco VSG Release 5.2(1)VSG1(4.1) to Release 5.2(1)VSG2(1.1a),  
Cisco VNMC Release 2.1 to Cisco Prime NSC Release 3.2 and Cisco Nexus 1000V Release  
5.2(1)SM1(5.1) to Release 5.2(1)SM1(5.2) 79Cisco VSG Release 5.2(1)VSG1(4.1) to 5.2(1)VSG2(1.1a) and Cisco VNMC 2.1 to Cisco  
Prime NSC 3.0.2 to Cisco Prime NSC 3.2 Staged Upgrade 79

Upgrading VNMC Release 2.1 to Cisco Prime NSC 3.0.2 82

Upgrading Cisco Prime NSC 3.0.2 to Cisco Prime NSC 3.2 84

Upgrading Cisco VSG from Release 5.2(1)VSG1(4.1) to 5.2(1)VSG2(1.1a) 86

Cisco VSG Software Upgrade Guidelines 86

Upgrade a VSG Pair in HA Mode 87

Upgrading a Device for Standalone VSG 90

Re-registering the Policy Agent with the Upgraded VSG 93

Upgrading the Cisco Nexus 1000V for Microsoft Hyper-V 94

Upgrading the Cisco Nexus 1000V for Microsoft Hyper-V 94



# Preface

---

This preface contains the following sections:

- [Audience, page vii](#)
- [Document Conventions, page vii](#)
- [Related Documentation for Cisco Virtual Security Gateway for Microsoft Hyper-V, page viii](#)
- [Documentation Feedback , page ix](#)
- [Obtaining Documentation and Submitting a Service Request, page ix](#)

## Audience

This publication is for network administrators and server administrators who understand virtualization.

## Document Conventions

Command descriptions use the following conventions:

Convention	Description
<b>bold</b>	Bold text indicates the commands and keywords that you enter literally as shown.
<i>Italic</i>	Italic text indicates arguments for which the user supplies the values.
[x]	Square brackets enclose an optional element (keyword or argument).
[x   y]	Square brackets enclosing keywords or arguments separated by a vertical bar indicate an optional choice.
{x   y}	Braces enclosing keywords or arguments separated by a vertical bar indicate a required choice.

Convention	Description
[x {y   z}]	Nested set of square brackets or braces indicate optional or required choices within optional or required elements. Braces and a vertical bar within square brackets indicate a required choice within an optional element.
<i>variable</i>	Indicates a variable for which you supply values, in context where italics cannot be used.
string	A nonquoted set of characters. Do not use quotation marks around the string or the string will include the quotation marks.

Examples use the following conventions:

Convention	Description
<code>screen font</code>	Terminal sessions and information the switch displays are in screen font.
<b><code>boldface screen font</code></b>	Information you must enter is in boldface screen font.
<i><code>italic screen font</code></i>	Arguments for which you supply values are in italic screen font.
<>	Nonprinting characters, such as passwords, are in angle brackets.
[ ]	Default responses to system prompts are in square brackets.
!, #	An exclamation point (!) or a pound sign (#) at the beginning of a line of code indicates a comment line.

This document uses the following conventions:



**Note**

Means *reader take note*. Notes contain helpful suggestions or references to material not covered in the manual.



**Caution**

Means *reader be careful*. In this situation, you might do something that could result in equipment damage or loss of data.

## Related Documentation for Cisco Virtual Security Gateway for Microsoft Hyper-V

This section lists the documents available for Cisco Virtual Security Gateway for Microsoft Hyper-V and related products.



### Cisco Virtual Security Gateway Documentation

The *Cisco Virtual Security Gateway for Microsoft Hyper-V* documentation is available at [http://www.cisco.com/en/US/products/ps13095/tsd\\_products\\_support\\_series\\_home.html](http://www.cisco.com/en/US/products/ps13095/tsd_products_support_series_home.html).

*Cisco Virtual Security Gateway for Microsoft Hyper-V Release Notes*

*Cisco Virtual Security Gateway for Microsoft Hyper-V Installation Guide*

*Cisco Virtual Security Gateway for Microsoft Hyper-V Configuration Guide*

*Cisco Virtual Security Gateway for Microsoft Hyper-V Troubleshooting Guide*

*Cisco Virtual Security Gateway for Microsoft Hyper-V Command Reference*

*Cisco vPath and vServices Reference Guide for Microsoft Hyper-V*

### Related Documentation for Nexus 1000V Series NX-OS for Microsoft Hyper-V Software

The *Cisco Nexus 1000V Series Switch for Microsoft Hyper-V* documents are available on Cisco.com at the following URL:

[http://www.cisco.com/en/US/products/ps13056/tsd\\_products\\_support\\_series\\_home.html](http://www.cisco.com/en/US/products/ps13056/tsd_products_support_series_home.html)

## Documentation Feedback

To provide technical feedback on this document, or to report an error or omission, please send your comments to [vsg-docfeedback@cisco.com](mailto:vsg-docfeedback@cisco.com). We appreciate your feedback.

## Obtaining Documentation and Submitting a Service Request

For information on obtaining documentation, using the Cisco Bug Search Tool (BST), submitting a service request, and gathering additional information, see *What's New in Cisco Product Documentation*, at: <http://www.cisco.com/en/US/docs/general/whatsnew/whatsnew.html>.

Subscribe to *What's New in Cisco Product Documentation*, which lists all new and revised Cisco technical documentation, as an RSS feed and deliver content directly to your desktop using a reader application. The RSS feeds are a free service.





## Overview

---

This chapter contains the following sections:

- [Information About Installing Cisco Prime NSC and Cisco VSG, page 1](#)
- [Information About Cisco Prime NSC, page 7](#)

## Information About Installing Cisco Prime NSC and Cisco VSG

You must install Cisco Prime NSC and Cisco VSG in a particular sequence on the Cisco Nexus 1000V switch to have a functioning virtual system. For the critical sequence information that you need for a successful installation on the Cisco Nexus 1000V switch, see Chapter 2, *Installing Cisco VSG and Cisco Prime NSC-Quick Start*. For installing Cisco VSG on the Cisco Cloud Service Platform Virtual Services Appliance, see Chapter 6, *Installing Cisco VSG on Cisco Cloud Service Platform Virtual Services Appliance*.

## Information About Cisco VSG

Cisco VSG is a virtual firewall appliance that provides trusted access to virtual data center and cloud environments with dynamic policy-driven operation, mobility-transparent enforcement, and scale-out deployment for dense multi-tenancy. By associating one or more Virtual Machines (VMs) into distinct trust zones, Cisco VSG ensures that access to trust zones is controlled and monitored through established security

policies. The following figure shows the trusted zone-based access control that is used in per-tenant enforcement with Cisco VSG.

**Figure 1: Trusted Zone-Based Access Control Using Per-Tenant Enforcement with Cisco VSG**

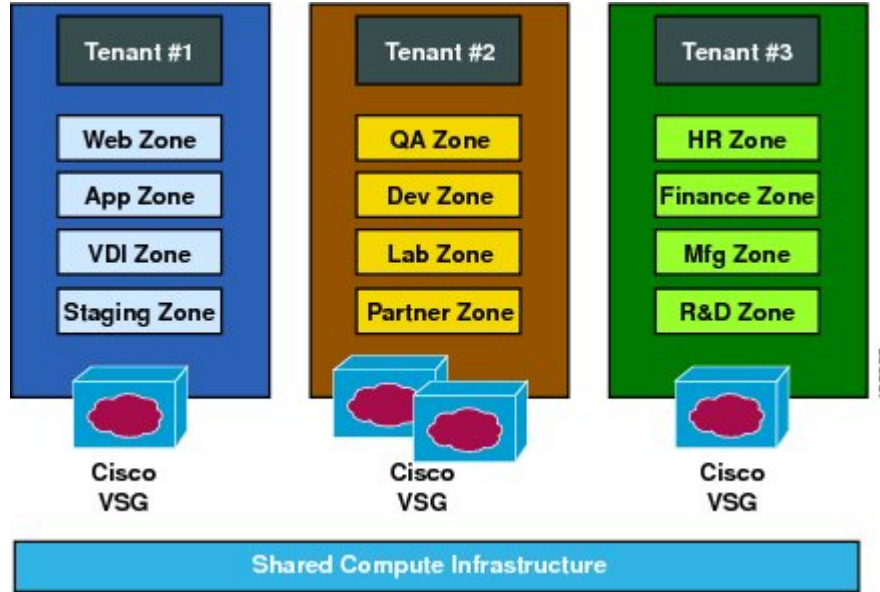

### Cisco Prime NSC and VSG Architecture

Cisco VSG operates with Cisco Nexus 1000V Series switch in Microsoft Hyper-V or Cisco Cloud Service Platform Virtual Services Appliance, and Cisco VSG leverages the virtual network service data path (Cisco vPath). Cisco vPath steers traffic, whether external-to-VM or VM-to-VM, to Cisco VSG of a tenant. Initial

packet processing occurs in Cisco VSG for policy evaluation and enforcement. After the policy decision is made, Cisco VSG offloads policy enforcement of the remaining packets to Cisco vPath.

**Figure 2: Cisco Virtual Security Gateway Deployment Topology**

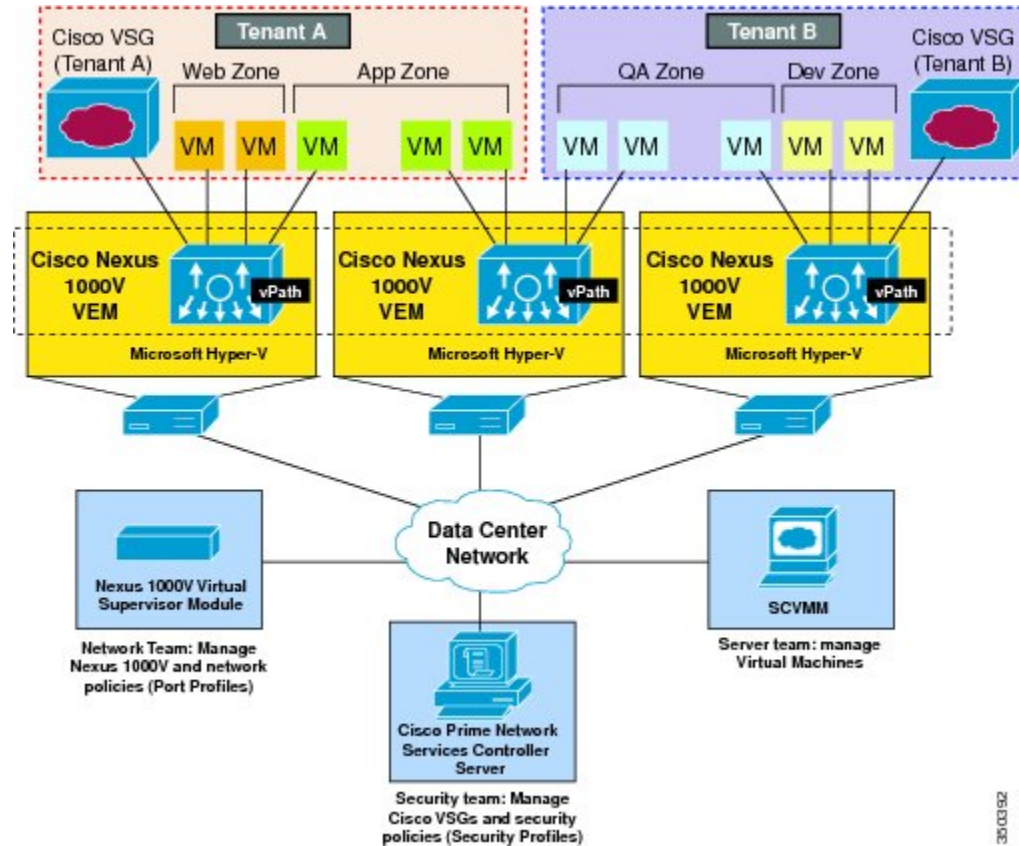

Cisco vPath supports the following features:

- Tenant-aware flow classification and subsequent redirection to a designated Cisco VSG tenant
- Per-tenant policy enforcement of flows offloaded by the Cisco VSG to Cisco vPath

Cisco VSG and the VEM provide the following benefits:

- Each Cisco VSG can provide protection across multiple physical servers, which eliminates the need for you to deploy a virtual appliance per physical server.
- By offloading the fast-path to one or more Cisco vPath Virtual Ethernet Modules (VEMs), Cisco VSG enhances security performance through distributed Cisco vPath-based enforcement.
- You can use Cisco VSG without creating multiple switches or temporarily migrating VMs to different switches or servers. Zone scaling, which is based on security profiles, simplifies physical server upgrades without compromising security or incurring application outages.
- For each tenant, you can deploy Cisco VSG in an active-standby mode to ensure that Cisco vPath redirects packets to the standby Cisco VSG when the primary Cisco VSG is unavailable.

- You can place Cisco VSG on a dedicated server so that you can allocate the maximum compute capacity to application workloads. This feature enables capacity planning to occur independently and allows for operational segregation across security, network, and server groups.

## Trusted Multitenant Access

You can transparently insert a Cisco VSG into the Microsoft Hyper-V environment where Cisco Nexus 1000V is deployed. One or more instances of Cisco VSG is deployed on a per-tenant basis, which allows a highly scale-out deployment across many tenants. Tenants are isolated from each other, so no traffic can cross tenant boundaries. You can deploy Cisco VSG at the tenant level in Hyper-V and manage each tenant instance using Microsoft System Center Virtual Machine Manager (SCVMM).

As you instantiate VMs for a given tenant, their association to security profiles (or zone membership) occurs immediately through binding with the Cisco Nexus 1000V port profile. Each VM is placed upon instantiation into a logical trust zone. Security profiles contain context-aware rule sets that specify access policies for traffic that enters and exits each zone. You can apply controls to zone-to-zone traffic and to external-to-zone (and zone-to-external) traffic. Zone-based enforcement occurs within a VLAN because a VLAN often identifies a tenant boundary. The Cisco VSG evaluates access control rules and then offloads enforcement to the Cisco Nexus 1000V VEM vPath module. Upon enforcement, Cisco VSG can permit or deny access and can generate optional access logs. Cisco VSG also provides policy-based traffic monitoring capability with access logs.

## Dynamic Virtualization-Aware Operation

A virtualization environment is dynamic, where frequent additions, deletions, and changes occur across tenants and across VMs. The following figure shows how the structured environment can change over time due to dynamic VMs.

**Figure 3: Cisco VSG Security in a Dynamic VM Environment, Including VM Live Migration**

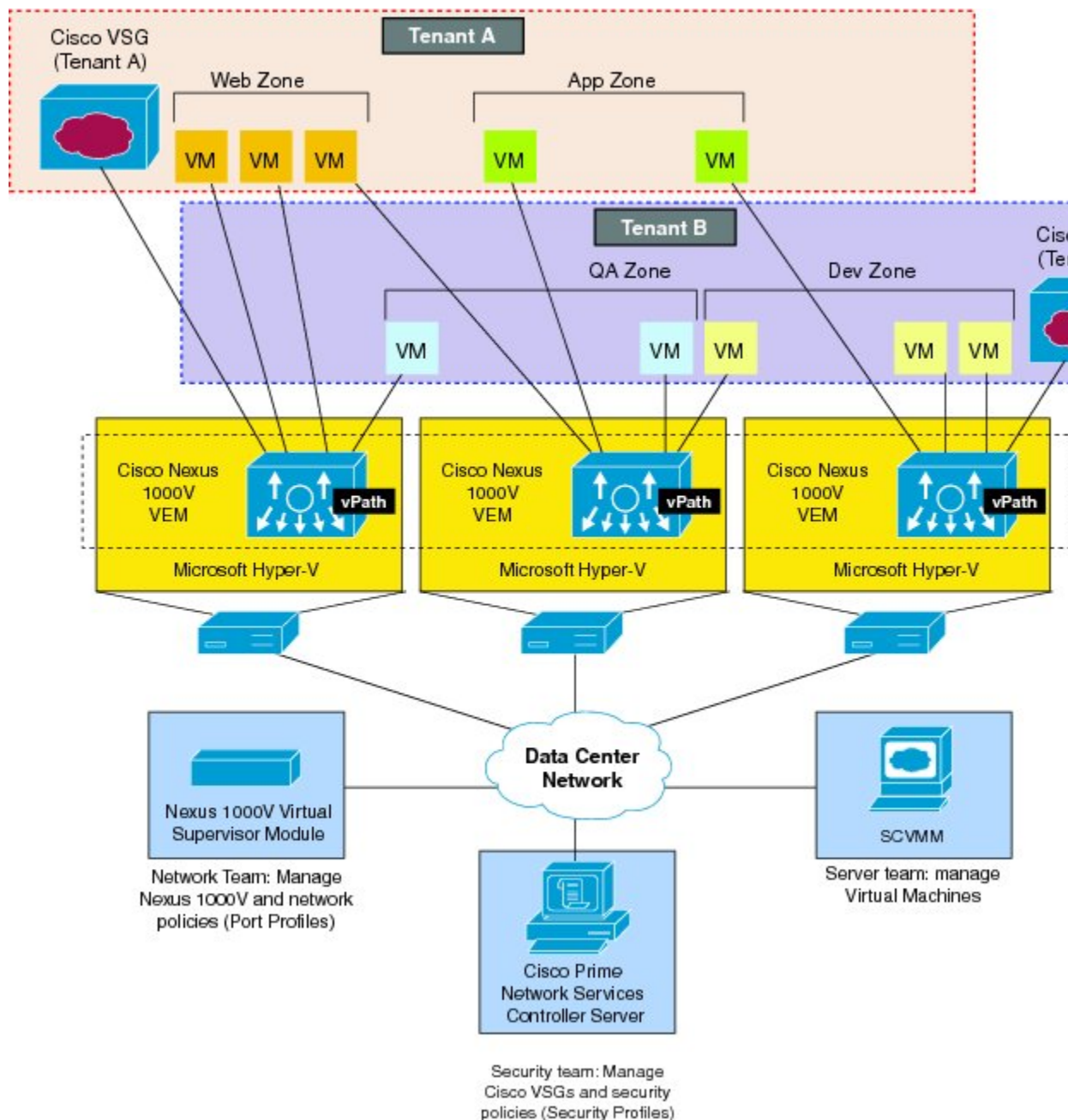

Cisco VSG operating with Cisco Nexus 1000V (and Cisco vPath) supports a dynamic VM environment. When you create a tenant with Cisco VSG (standalone or active-standby pair) on Cisco Prime NSC, associated security profiles are defined that include trust zone definitions and access control rules. Each security profile is bound to a Cisco Nexus 1000V port profile (authored on the Cisco Nexus 1000V Virtual Supervisor Module (VSM) and published to Microsoft SCVMM.

When a new VM is instantiated, the server administrator assigns appropriate port profiles to the virtual Ethernet port of the VM. Because the port profile uniquely refers to a security profile and VM zone membership, Cisco VSG immediately applies the security controls. You can repurpose a VM by assigning it to a different port profile or security profile.

As VM migration events are triggered, VMs move across physical servers. Because Cisco Nexus 1000V ensures that port profile policies follow the VMs, associated security profiles also follow these moving VMs, and security enforcement and monitoring remain transparent to the migration events.

## Setting Up Cisco VSG and VLAN

You can set up Cisco VSG in an overlay fashion so that VMs can reach Cisco VSG irrespective of its location. The Cisco vPath component in Cisco Nexus 1000V VEM intercepts the packets from the VM and sends them to Cisco VSG for further processing.

In the following figure, Cisco VSG connects to three different VLANs (service VLAN, management VLAN, and HA VLAN). Cisco VSG is configured with three vNICs—data vNIC (1), management vNIC (2), and HA vNIC (3)—with each of the vNICs connected to one of the VLANs through a port profile.

**Figure 4: Cisco Virtual Security Gateway VLAN Usages**

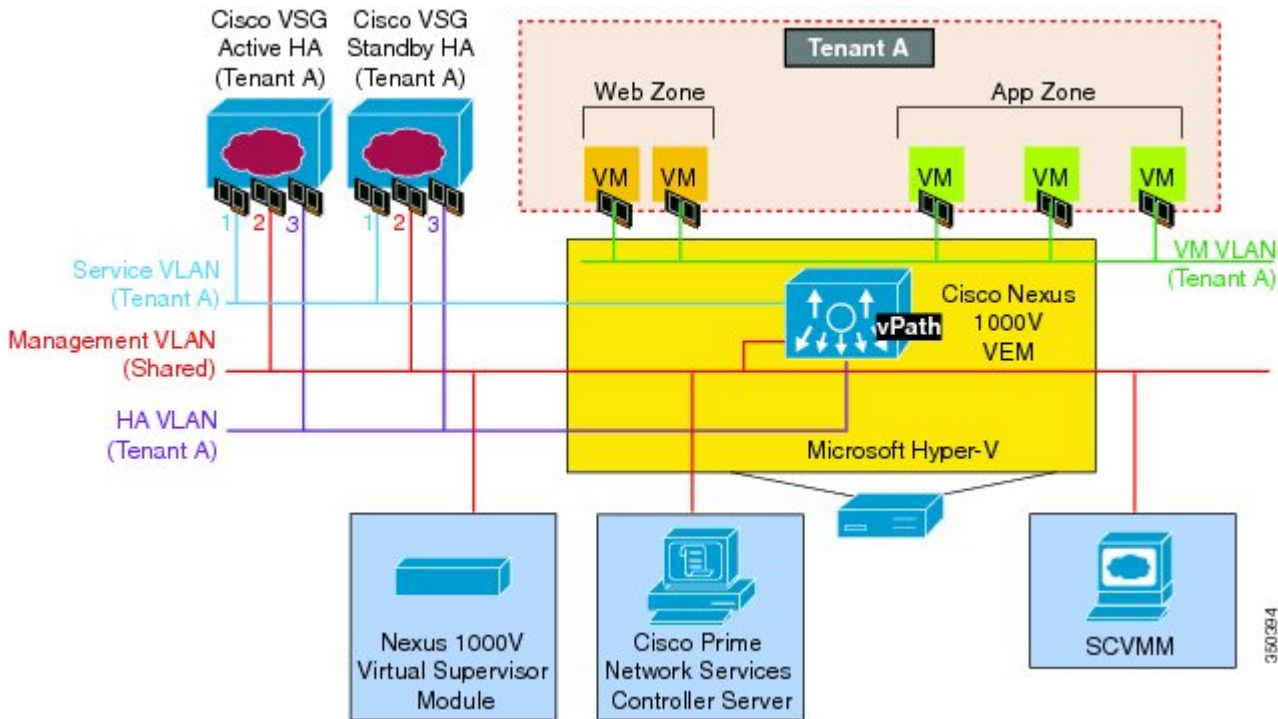

The VLAN functions are as follows:



- The service VLAN provides communications between Cisco Nexus 1000V VEM and Cisco VSG through a physical router. Cisco VSG data interface and VEM interface are configured on different subnets. All the Cisco VSG data interfaces are part of the service VLAN and the VEM interacts with Cisco VSG using the router.
- The management VLAN connects the management platforms such as Microsoft SCVMM, Cisco Prime NSC, Cisco Nexus 1000V VSM, and managed Cisco VSGs. The Cisco VSG management vNIC is part of the management VLAN.
- The HA VLAN provides the heartbeat mechanism and identifies the active and standby relationship between the Cisco VSGs. The Cisco VSG vNICs are part of the HA VLAN.

You can allocate one or more VM data VLANs for VM-to-VM communications. In a typical multi-tenant environment, the management VLAN is shared among all the tenants and the service VLAN, HA VLAN, and the VM data. VLANs are allocated on a per-tenant basis. However, when VLAN resources become scarce, you might decide to use a single VLAN for service and HA functions.

## Information About Cisco Prime NSC

Cisco Prime NSC virtual appliance is based on Red Hat Enterprise Linux (RHEL), which provides centralized device and security policy management of Cisco VSG for Cisco Nexus 1000V Series switch. Designed for multi-tenant operation, Cisco Prime NSC provides seamless, scalable, and automation-centric management for virtual data center and cloud environments. With a web-based GUI, CLI, and XML APIs, Cisco Prime NSC enables you to manage Cisco VSGs that are deployed throughout the data center from a centralized location.



### Note

Multi-tenancy is when a single instance of the software runs on a Software-as-a-Service (SaaS) server, serving multiple client organizations or tenants. In contrast, multi-instance architecture has separate software instances set up for different client organizations. With a multi-tenant architecture, a software application can virtually partition data and configurations so that each tenant works with a customized virtual application instance.

Cisco Prime NSC is built on an information model-driven architecture, where each managed device is represented by its subcomponents.

## Cisco Prime NSC Key Benefits

Cisco Prime NSC provides the following key benefits:

- Rapid and scalable deployment with dynamic, template-driven policy management based on security profiles.
- Seamless operational management through XML APIs that enable integration with third-party management tools.
- Greater collaboration across security and server administrators, while maintaining administrative separation and reducing administrative errors.

## Cisco Prime NSC Components

Cisco Prime NSC architecture includes the following components:

- A centralized repository for managing security policies (security templates) and object configurations that allow managed devices to be stateless.
- A centralized resource management function that manages pools of devices that are commissioned and pools of devices that are available for commissioning. This function simplifies large scale deployments as follows:
  - Devices can be pre-instantiated and then configured on demand
  - Devices can be allocated and deallocated dynamically across commissioned and noncommissioned pools
- A distributed management-plane function that uses an embedded management agent on each device that allows for a scalable management framework.

## Cisco Prime NSC Architecture

The Cisco Prime NSC architecture includes the components in the following figure:

**Figure 5: Cisco Prime NSC Components**

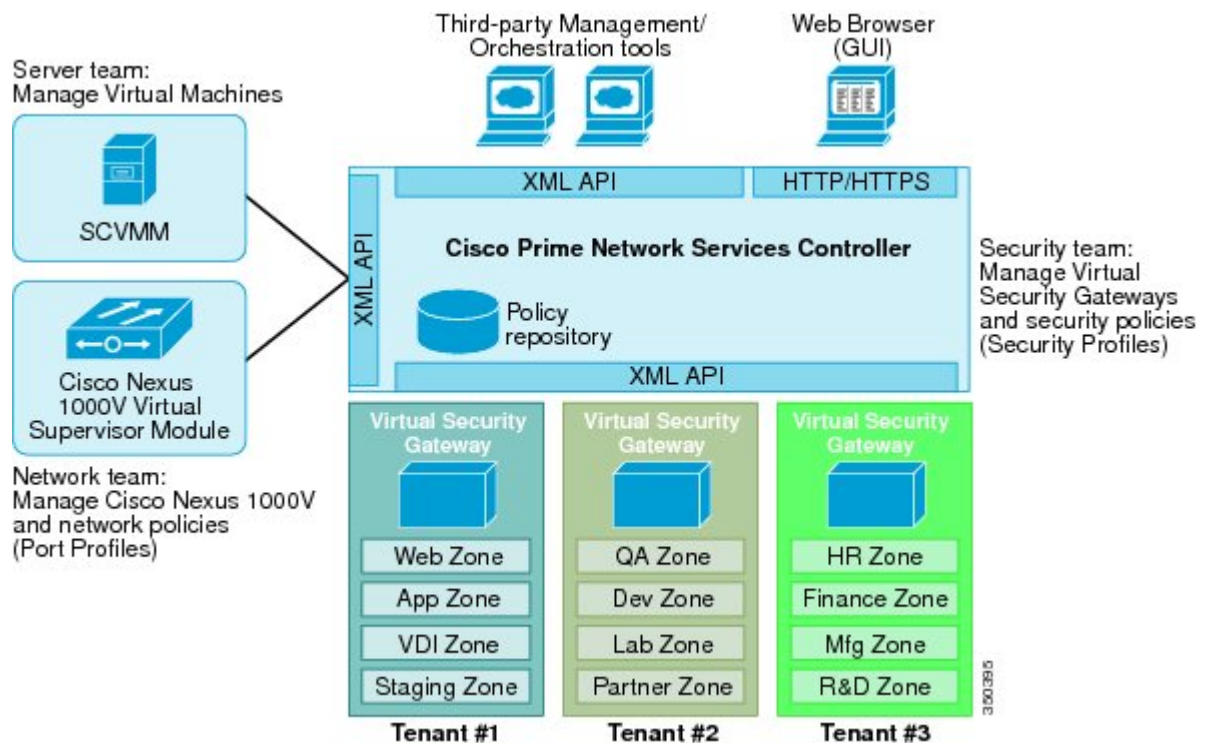

## Cisco Prime NSC Security

Cisco Prime NSC uses security profiles for tenant-centric template-based configuration of security policies. A security profile is a collection of security policies that are predefined and applied on an on-demand basis at the time of Virtual Machine (VM) instantiation. These profiles simplify authoring, deployment, and management of security policies in a dense multi-tenant environment, reduce administrative errors, and simplify audits.

## Cisco Prime NSC API

The Cisco Prime NSC API allows you to coordinate with third-party provisioning tools for programmatic provisioning and management of Cisco VSGs. This feature allows you to simplify data center operational processes and reduce the cost of infrastructure management.

## Cisco Prime NSC and VSG

Cisco Prime NSC operates with the Cisco Nexus 1000V Series VSM to achieve the following scenarios:

- Security administrators who author and manage security profiles as well as manage Cisco VSG instances. Security profiles are referenced in Cisco Nexus 1000V Series port profiles through Cisco Prime NSC interface.
- Network administrators who author and manage port profiles as well as manage Cisco Nexus 1000V Series switches. Port profiles are referenced in Microsoft SCVMM through the Cisco Nexus 1000V Series VSM interface.
- Server administrators who select the appropriate port profiles in Microsoft SCVMM when instantiating a virtual machine.

## System Requirements

System requirements for Cisco Prime NSC are as follows:

- Microsoft Windows Server with SCVMM 2012 SP1 or SCVMM 2012 R2.
- Intel VT that is enabled in the BIOS.
- 4 GB RAM for Prime NSC ISO installation.
- 40 GB on shared NFS or SAN, and configured on two hard disks as follows:
  - Disk 1: 20 GB
  - Disk 2: 20 GB
- Adobe Flash Player plugin 11.2 or higher.
- Any of the following browsers:
  - Internet Explorer 9.0 or higher

- Mozilla Firefox 23.0 or higher
- Google Chrome 29.0 or higher

Access to Cisco Prime NSC application using a Web browser and the following ports (if the deployment uses a firewall, make sure to permit the following ports):

- 443 (HTTPS)
- 80 (HTTP/TCP)
- 843 (Adobe Flash)

**Note**

---

If you are running Firefox or IE and do not have Flash, or you have a version of Flash that is older than 11.2, a message displays asking you to install Flash and provides a link to the Adobe website.

---



## Installing the Cisco Prime NSC and Cisco VSG-Quick Start

---

This chapter contains the following sections:

- [Information About Installing Cisco Prime NSC and Cisco VSG](#), page 11
- [Task 1: Installing the Cisco Prime NSC from an ISO Image](#), page 19
- [Task 2: On the VSM, Configuring Cisco Prime NSC Policy Agent](#), page 22
- [Task 3: On the VSM, Preparing Cisco VSG Port Profiles](#), page 24
- [Task 4: On the VSM, Configuring Virtual Network Adapters on the Hosts](#), page 26
- [Task 5: Installing Cisco VSG from an ISO Image](#), page 27
- [Task 6: On the VSG, Configuring the Cisco Prime NSC Policy Agent](#), page 31
- [Task 7: On Cisco VSG, Cisco VSM, and Cisco Prime NSC, Verifying the NSC Policy-Agent Status](#), page 32
- [Task 8: On Cisco Prime NSC, Configuring a Tenant, Security Profile, Compute Firewall, and Assigning Cisco VSG to the Compute Firewall](#), page 33
- [Task 9: On the Prime NSC, Configuring a Permit-All Rule](#), page 36
- [Task 10: On Cisco VSG, Verifying the Permit-All Rule](#), page 36
- [Task 11: Enabling Logging](#), page 37
- [Task 12: Enabling the Traffic VM Port-Profile for Firewall Protection and Verifying the Communication Between the VSM, VEM, and VSG](#), page 38
- [Task 13: Installing Microsoft Service Provider Foundation](#), page 41
- [Task 14: Sending Traffic Flow and on Cisco VSG Verifying Statistics and Logs](#), page 43

## Information About Installing Cisco Prime NSC and Cisco VSG

This chapter describes how to install and set up a basic working configuration of Cisco Prime Network Services Controller (Cisco Prime NSC) and Cisco Virtual Security Gateway (Cisco VSG). The example in this chapter

uses the ISO files of the software for installation. The steps assume that Cisco Nexus 1000V Series switch is operational, and endpoint VMs are already installed.

## Cisco VSG and Cisco Prime NSC Installation Planning Checklists

Planning the arrangement and architecture of your network and equipment is essential for a successful operation of Cisco Prime NSC and Cisco VSG.

### Basic Hardware and Software Requirements

The following table lists the basic hardware and software requirements for Cisco VSG and Cisco Prime NSC installation.

Requirement	Description
Virtual CPUs	<ul style="list-style-type: none"> <li>• Cisco VSG: 1 (1.5 GHz)</li> <li>• Cisco Prime NSC: 4 (1.8 GHz each)</li> </ul>
Memory	<ul style="list-style-type: none"> <li>• Cisco VSG: 2GB RAM</li> <li>• Cisco Prime NSC: 4GB RAM</li> </ul>
Disk Space	Cisco VSG: 3 GB Cisco Prime NSC: Without InterCloud functionality, 40 GB on shared NFS or SAN, and configured on two disks as follows: <ul style="list-style-type: none"> <li>• Disk 1: 20 GB</li> <li>• Disk 2: 20 GB</li> </ul>
Processor	x86 Intel or AMD server with a 64-bit processor.
Network Interfaces	<ul style="list-style-type: none"> <li>• Cisco VSG: 3</li> <li>• Cisco Prime NSC: 1</li> </ul>
Microsoft SCVMM	SCVMM 2012 SP1 or SCVMM 2012 R2

Requirement	Description
Browser	<p>Any of the following browsers:</p> <ul style="list-style-type: none"> <li>• Internet Explorer 9.0 or higher</li> <li>• Mozilla Firefox 23.0 or higher</li> <li>• Google Chrome 29.0 or higher</li> </ul> <p><b>Note</b> If you are running Firefox or IE and do not have Flash, or you have a version of Flash that is older than 11.2, a message displays asking you to install Flash and provides a link to the Adobe website.</p> <p><b>Note</b> Before using Google Chrome with Cisco Prime NSC, you must disable the Adobe Flash Players that are installed by default with Chrome. For more information, see <a href="#">Configuring Chrome for Use with Cisco Prime NSC</a>.</p>
Ports	<p>Access to the Cisco Prime NSC application using a web browser and the following ports (if the deployment uses a firewall, make sure to permit the following ports):</p> <ul style="list-style-type: none"> <li>• 443 (HTTPS)</li> <li>• 80 (HTTP/TCP)</li> <li>• 843 (Adobe Flash)</li> </ul>
Flash Player	Adobe Flash Player plugin 11.2 or higher

**Note**

The Cisco VSG software is available for download at <http://www.cisco.com/en/US/products/ps13095/index.html> and the Cisco Prime NSC software is available for download at <http://www.cisco.com/en/US/products/ps13213/index.html>.

## License Requirements

Cisco VSG license is integrated with the Nexus1000V Multi-Hypervisor License. You need to install the Nexus1000V Multi-Hypervisor License for Cisco VSG for Microsoft Hyper-V. The Cisco N1kv VSM is available in two modes: essential and advanced. VSG functionality is available only in the advanced mode. You need to install the Nexus1000V Multi-Hypervisor License and change the VSM mode to advanced mode. When the Nexus1000V Multi-Hypervisor License is installed, the license for Cisco VSG is automatically included.

**Note**

If you try to access VSG services with VSM in essential mode, an error message is generated on VSM console indicating that the Nexus1000V Multi-Hypervisor License is required for VSG.

The Nexus1000V Multi-Hypervisor License in the Release 5.2(1)SM1(5.2) is available in three different types:

- Default: The Nexus 1000v switch may be configured in Essential or Advanced mode.
  - Essential Mode: Not Supported.
  - Advanced Mode: After upgrade to Software Release 5.2(1)SM(5.2) - Nexus1000V Multi-Hypervisor License is available with 1024 Socket Count and expires in 60 days.

**Note**

You must install either the evaluation or the permanent (MSFT PKG) license prior to upgrading to the Software Release 5.2(1)SM(5.2).

- Evaluation: The Nexus 1000V switch should be in Advanced mode. After upgrading to Software Release 5.2(1)SM(5.2) - Nexus1000V Multi-Hypervisor License is available with 1024 Socket Count and expires in 60 days.
- Permanent: The Nexus 1000V switch should be in Advanced mode. After upgrading to Software Release 5.2(1)SM(5.2) - Nexus1000V Multi-Hypervisor License is available with 1024 Socket Count and expires in 60 days.

**Note**

You have to request for an evaluation or permanent Nexus1000V Multi-Hypervisor License.

For more information about the Cisco Nexus 1000V for Microsoft Hyper-V licenses, see the *Cisco Nexus 1000V for Microsoft Hyper-V License Configuration Guide*.

## VLAN Configuration Requirements for VSG

You must have two port-profiles configured on two different VLANs in the VSM:

- Service interface VLAN
- HA interface VLAN

## Required Cisco Prime NSC and Cisco VSG Information

The following information can be used during the Cisco Prime NSC and Cisco VSG installation.

Type	Your Information
Cisco VSG name—Unique within the inventory folder and up to 80 characters	



Type	Your Information
Hostname—Where the Cisco VSG will be installed in the inventory folder	
ISOs—Managed within SCVMM library, if stored at C:\ProgramData\Virtual Machine Manager Library Files\ISO to manage. Refresh the SCVMM library after saving the ISO file to the specified location.	
Cisco VSG management IP address	
VSM management IP address	
Cisco Prime NSC instance IP address	
Mode for installing the Cisco VSG	<ul style="list-style-type: none"> <li>• Standalone</li> <li>• HA primary</li> <li>• HA secondary</li> </ul>
Cisco VSG VLAN number <ul style="list-style-type: none"> <li>• Service (1)</li> <li>• Management (2)</li> <li>• High availability (HA) (3)</li> </ul>	
Cisco VSG port profile name <ul style="list-style-type: none"> <li>• Data (1)</li> <li>• Management (2)</li> <li>• High availability (HA) (3)</li> </ul> <p><b>Note</b> The numbers indicate the Cisco VSG port profile that must be associated with the Cisco VSG VLAN number.</p>	
HA pair ID (HA domain ID)	
Cisco VSG admin password	
Cisco Prime NSC admin password	
Cisco VSM admin password	
Shared secret password (Cisco Prime NSC, Cisco VSG policy agent, Cisco VSM policy agent)	

Type	Your Information
NSC DNS IP address	
NSC NTP IP address	

## Tasks and Prerequisites Checklist

Tasks	Prerequisites
<a href="#">Task 1: Installing the Cisco Prime NSC from an ISO Image.</a>	<p>Make sure that you know the following:</p> <ul style="list-style-type: none"> <li>• Verified that the Hyper-V host on which to deploy Cisco Prime NSC VM is available in SCVMM.</li> <li>• Copied the Cisco Prime NSC 3.2 ISO image to the SCVMM library location on the file system. To make this image available in SCVMM, choose <b>Library &gt; Library Servers</b>, right-click the library location, and then refresh.</li> <li>• NTP server information.</li> </ul>
<a href="#">Task 2: On the VSM, Configuring Cisco Prime NSC Policy Agent, on page 22</a>	<p>Make sure that you know the following:</p> <ul style="list-style-type: none"> <li>• Cisco Prime NSC policy-agent image on the VSM (for example, vsmhv-pa.3.2.1c.bin) <ul style="list-style-type: none"> <li><b>Note</b> The string <b>vsmhv-pa</b> must appear in the image name as highlighted.</li> </ul> </li> <li>• The IP address of Cisco Prime NSC</li> <li>• The shared secret password you defined during Cisco Prime NSC installation</li> <li>• IP connectivity between the VSM and Cisco Prime NSC is working <ul style="list-style-type: none"> <li><b>Note</b> If you upgrade your VSM, you must also copy the latest Cisco VSM policy agent image. This image is available in Cisco Prime NSC image bundle to boot from a flash drive and to complete registration with Cisco Prime NSC.</li> </ul> </li> </ul>

Tasks	Prerequisites
<p><a href="#">Task 3: On the VSM, Preparing Cisco VSG Port Profiles, on page 24</a></p>	<p>Make sure that you know the following:</p> <ul style="list-style-type: none"> <li>• Logical Switch name (Network Uplink port-profile name).</li> <li>• VLAN ID for the Cisco VSG data interface (for example,100).</li> <li>• VLAN ID for the Cisco VSG-ha interface (for example, 200).</li> <li>• Management VLAN (management).</li> </ul> <p><b>Note</b> None of these VLANs need to be system VLANs.</p>
<p><a href="#">Task 4: On the VSM, Configuring Virtual Network Adapters on the Hosts, on page 26</a></p>	<p>Make sure that you know the following:</p> <ul style="list-style-type: none"> <li>• Cisco VSG port-profile configured on VSM.</li> </ul>
<p><a href="#">Task 5: Installing Cisco VSG from an ISO Image, on page 27</a></p>	<p>Make sure that you know the following:</p> <ul style="list-style-type: none"> <li>• Installed Microsoft SCVMM SP1 or SCVMM R2.</li> <li>• Downloaded the Cisco VSG ISO image and uploaded it to the server (C:\ProgramData\Virtual Machine Manager Library Files\ISO). Refresh the library server under the Library tab.</li> <li>• Cisco VSG-Data port profile: VSG-Data.</li> <li>• Cisco VSG-ha port profile: VSG-ha.</li> <li>• HA ID.</li> <li>• IP/subnet mask/gateway information for Cisco VSG</li> <li>• Administrator password</li> <li>• Minimum of 2 GB RAM and 2 GB hard disk space, recommended space is 4 GB RAM and 4 GB hard disk.</li> <li>• Cisco Prime NSC IP address.</li> <li>• The shared secret password.</li> <li>• IP connectivity between Cisco VSG and Cisco Prime NSC is okay.</li> <li>• Cisco VSG NSC-PA image name (vsghv-pa.2.1.1e.bin) is available.</li> </ul>

Tasks	Prerequisites
Task 6: On the VSG, Configuring the Cisco Prime NSC Policy Agent, on page 31	<p>Make sure that you know the following:</p> <ul style="list-style-type: none"> <li>The Cisco Prime NSC policy-agent image on Cisco VSG (for example, vsghv-pa.2.1.1e.bin).</li> </ul> <p><b>Note</b> The string <b>vsghv-pa</b> must appear in the image name as highlighted.</p> <ul style="list-style-type: none"> <li>IP address of the Cisco Prime NSC.</li> <li>Shared secret password you defined during the Cisco Prime NSC installation.</li> <li>IP connectivity between the VSG and the Cisco Prime NSC.</li> </ul> <p><b>Note</b> If you upgrade your VSG, you must also copy the latest Cisco VSG policy agent image. This image is available in Cisco Prime NSC image bundle to boot from a flash drive and to complete registration with Cisco Prime NSC.</p>
Task 7: On Cisco VSG, Cisco VSM, and Cisco Prime NSC, Verifying the NSC Policy-Agent Status, on page 32	—
Task 8: On Cisco Prime NSC, Configuring a Tenant, Security Profile, Compute Firewall, and Assigning Cisco VSG to the Compute Firewall, on page 33	<p>Make sure that you know the following:</p> <ul style="list-style-type: none"> <li>Adobe Flash Player (version 11.2 or later) has been installed</li> <li>The IP address of the Cisco Prime NSC</li> <li>The admin user password</li> </ul>
Task 13: Installing Microsoft Service Provider Foundation, on page 41	—
Task 9: On Cisco Prime NSC, Assigning Cisco VSG to the Compute Firewall	—
Task 9: On the Prime NSC, Configuring a Permit-All Rule, on page 36	—
Task 10: On Cisco VSG, Verifying the Permit-All Rule, on page 36	—
Task 11: Enabling Logging, on page 37	—

Tasks	Prerequisites
<a href="#">Task 12: Enabling the Traffic VM Port-Profile for Firewall Protection and Verifying the Communication Between the VSM, VEM, and VSG, on page 38</a>	<p>Make sure that you know the following:</p> <ul style="list-style-type: none"> <li>• The server VM that runs with an access port profile (for example, web server)</li> <li>• The Cisco VSG data IP address (for example, 10.10.10.200) and VLAN ID (for example, 100)</li> <li>• The security profile name (for example, sp-web)</li> <li>• The organization (Org) name (for example, root/Tenant-A)</li> <li>• The port profile that you would like to edit to enable firewall protection</li> <li>• That one active port in the port-profile with Cisco vPath configuration has been set up</li> </ul>
<a href="#">Task 14: Sending Traffic Flow and on Cisco VSG Verifying Statistics and Logs, on page 43</a>	—

## Host Requirements

- Microsoft SCVMM SP1 or SCVMM R2
- Microsoft Windows Server 2012 or Windows Server 2012 R2
- 6 GB RAM

## Obtaining Cisco Prime NSC and Cisco VSG Software

Cisco VSG software is available for download at the following URL:

<http://software.cisco.com/download/navigator.html>

Cisco Prime NSC software is available for download at the following URL:

<http://software.cisco.com/download/navigator.html>

# Task 1: Installing the Cisco Prime NSC from an ISO Image

## Before You Begin

Ensure that you have:

- Verified that the Hyper-V host on which to deploy Cisco Prime NSC VM is available in SCVMM.
- Copied the Cisco Prime NSC 3.2 ISO image to the SCVMM library location on the file system. To make this image available in SCVMM, choose **Library > Library Servers**, right-click the library location, and then refresh.

- NTP server information.

**Step 1** Launch the SCVMM.

**Figure 6: Create Virtual Machine Wizard - Select Source**

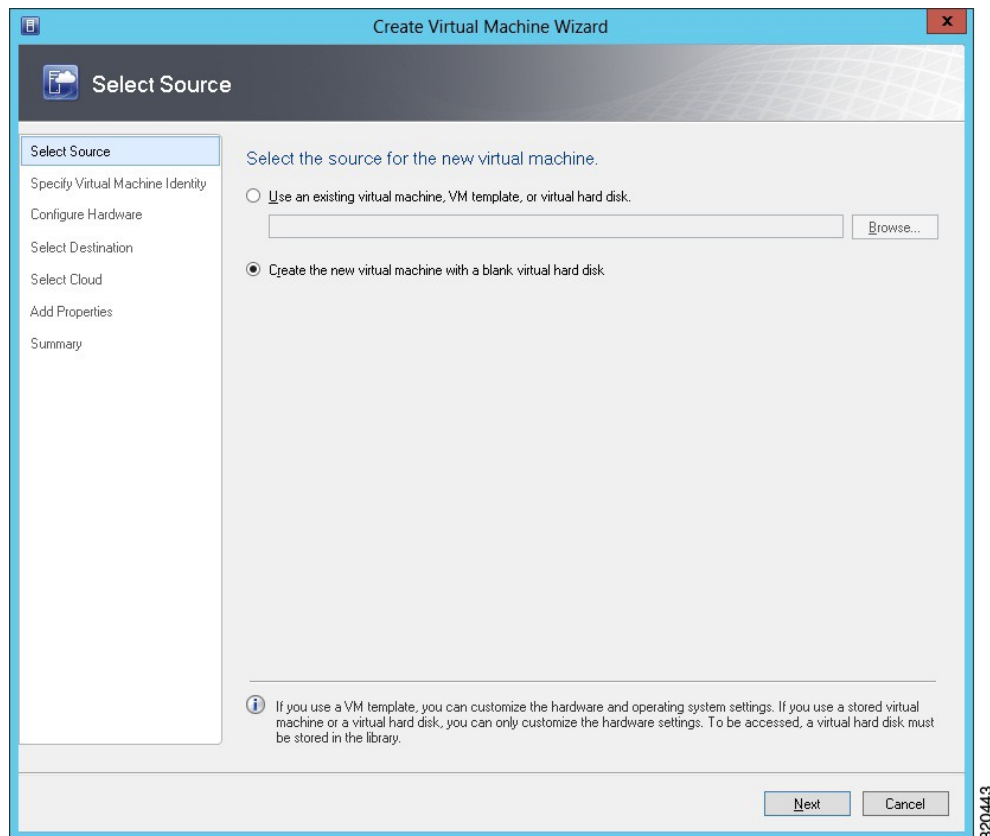

**Step 2** In the **VMs and Services** pane, choose the Hyper-V host on which to deploy the Cisco Prime NSC VM.

**Step 3** Right-click the Hyper-V host and choose **Create Virtual Machine**.

**Step 4** In the Create Virtual Machine wizard, from the **Select Source** screen, choose the **Create the new virtual machine with a blank virtual hard disk** radio button, and then click **Next**.

**Step 5** In the **Specify Virtual Machine Identity** screen, Specify the name and description for the virtual machine, and then click **Next**.

**Step 6** In the **Configure Hardware** screen, do the following:

a) From **General**, do the following:

- Choose **Processor** and set the number of processors.
- Choose **Memory** and choose the required memory value. You will need a minimum 4 GB of memory.

b) From **Bus Configuration > IDE Devices**, do the following:

- Choose the hard disk with the virtual machine name you specified and enter the required size of the hard disk. You will need at least 20 GB.
  - Click **New > Disk** to add a new hard disk, enter hard disk name in the **File Name** field, set the hard disk size to 20 GB and click **Ok**.
  - Choose **Virtual DVD Drive**, choose the **Existing ISO image file** radio button, and browse to select the Cisco Prime NSC 3.2 ISO image file from the library in the **Select ISO** dialog box.
- c) Choose **Network Adapters > Network Adapter 1**, select the **Connect to a VM Network** radio button, and browse to select a VM Network.
- d) Click **Next**.

**Step 7** In the **Select Destination** screen, do the following:

- a) Choose the **Place the virtual machine on a host** radio button.
- b) From the **Destination** drop-down list, choose **All hosts**.
- c) Click **Next**.

**Step 8** In the **Select Host** screen, choose the destination, and then click **Next**.

**Step 9** In the **Configure Settings** screen, click **Browse** and navigate to the storage location of virtual machine file, and then click **Next**.

**Step 10** In the **Add properties** screen, choose the **Red Hat Enterprise Linux 5 (64 bit)** operating system, and then click **Next**.

**Step 11** In the **Summary** screen, do the following:

- a) Verify the settings.
- b) Check the **Start the virtual machine after deploying it** check box.

- c) Click **Create**.

**Figure 7: Create Virtual Machine Wizard - Summary**

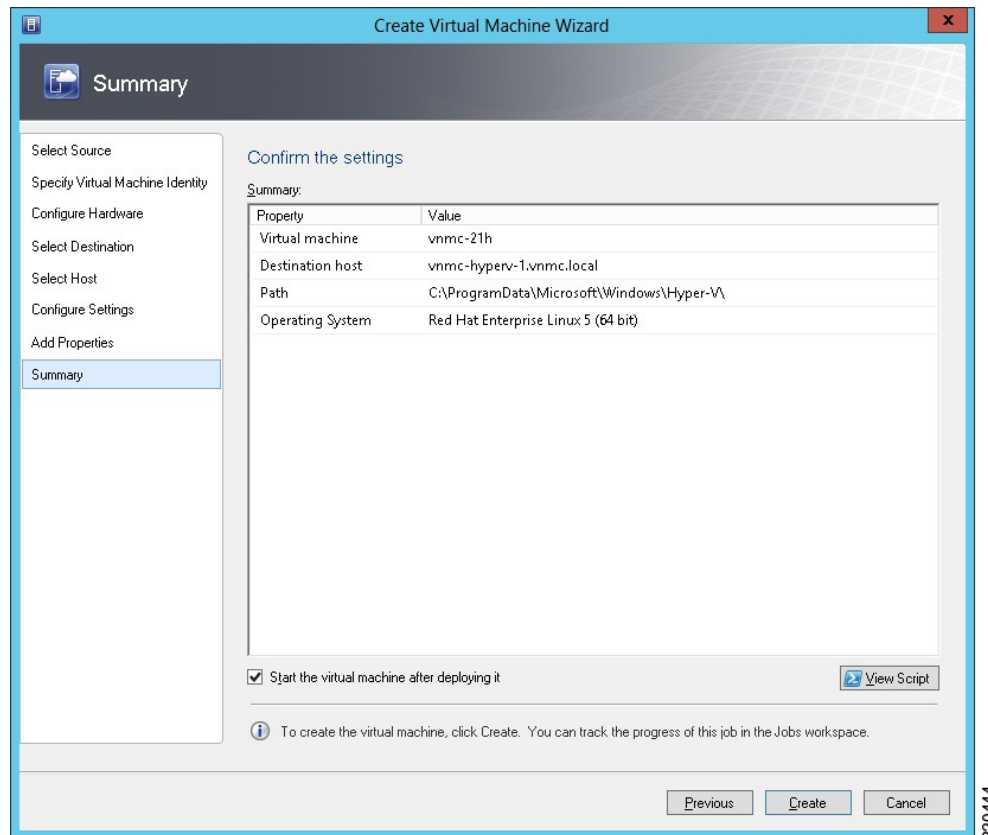

The job Create VM starts. You can see the status of this job in the **Recent Jobs** window. Ensure that the job completes without any errors.

- Step 12** After the VM is successfully created, right-click the new Virtual Machine and choose **Connect or View > Connect Via Console**.
- Step 13** Launch the console and install Cisco Prime NSC.  
**Note** Before the final Cisco Prime NSC installation step, before you reboot, launch SCVMM again, and right-click the Virtual machine and choose **Properties > Hardware Configuration > Bus Configuration > Virtual DVD Drive > no media**, so that Cisco Prime NSC does not use the ISO image at boot time.
- Step 14** After Cisco Prime NSC is successfully deployed, click **Close** and power on the Cisco Prime NSC VM.

## Task 2: On the VSM, Configuring Cisco Prime NSC Policy Agent

Once Cisco Prime NSC is installed, you must register the VSM with Cisco Prime NSC.



## Before You Begin

Ensure that you have:

- Cisco Prime NSC policy-agent image on the VSM (for example, vsmhv-pa.3.2.1c.bin)



---

**Note** The string **vsmhv-pa** must appear in the image name as highlighted.

---

- The IP address of Cisco Prime NSC
- The shared secret password you defined during Cisco Prime NSC installation
- IP connectivity between the VSM and Cisco Prime NSC is working



---

**Note** If you upgrade your VSM, you must also copy the latest Cisco VSM policy agent image. This image is available in Cisco Prime NSC image bundle to boot from a flash drive and to complete registration with Cisco Prime NSC.

---



---

**Note** VSM clock should be synchronized with Cisco Prime NSC clock.

---

## SUMMARY STEPS

1. On the VSM, enter the following commands:
2. Check the status of the NSC policy agent configuration to verify that you have installed Cisco Prime NSC correctly and it is reachable by entering the **show nsc-pa status** command. This example shows that Cisco Prime NSC is reachable and the installation is correct:

## DETAILED STEPS

### Step 1

On the VSM, enter the following commands:

```
vsm# configure terminal
vsm(config)# nsc-policy-agent
vsm(config-nsc-policy-agent)# registration-ip 10.193.75.95
vsm(config-nsc-policy-agent)# shared-secret Example_Secret123
vsm(config-nsc-policy-agent)# policy-agent-image vsmhv-pa.3.2.1c.bin
vsm(config-nsc-policy-agent)# exit
vsm(config)# copy running-config startup-config
vsm(config)# exit
```

### Step 2

Check the status of the NSC policy agent configuration to verify that you have installed Cisco Prime NSC correctly and it is reachable by entering the **show nsc-pa status** command. This example shows that Cisco Prime NSC is reachable and the installation is correct:

```
vsm# show nsc-pa status
NSC Policy-Agent status is - Installed Successfully. Version 3.2(1)-vsm
vsm
```

The VSM is now registered with Cisco Prime NSC.

This example shows that Cisco Prime NSC is unreachable or an incorrect IP is configured:

```
vsm# show nsc-pa status
nsc Policy-Agent status is - Installation Failure
Cisco Prime NSC not reachable.
vsm#
```

This example shows that the NSC policy-agent is not configured or installed:

```
vsm# show nsc-pa status
NSC Policy-Agent status is - Not Installed
```

## Task 3: On the VSM, Preparing Cisco VSG Port Profiles

To prepare Cisco VSG port profiles, you must create the VLANs and use the VLANs in Cisco VSG data port profile and the Cisco VSG-ha port profile.

### Before You Begin

Ensure that you have:

- Logical Switch name (Network Uplink port-profile name).
- VLAN ID for the Cisco VSG data interface (for example, 100).
- VLAN ID for the Cisco VSG-ha interface (for example, 200).
- Management VLAN (management).



**Note** None of these VLANs need to be system VLANs.

### SUMMARY STEPS

1. Create a Cisco VSG data port profile and a Cisco VSG-ha port profile by first enabling the Cisco VSG data port-profile configuration mode. Cisco VSG data interface should be in the system VLAN. To configure VSG data interface in the system VLAN, you need a system network segment, a system port-profile, and an uplink configured as a system uplink. Use the **configure** command to enter global configuration mode.
2. Create Network Uplink port-profile and use it in the Logical Switch.
3. Create the network segment and port-profile for the Data VLAN.
4. Create the network segment and port-profile for the HA VLAN.

### DETAILED STEPS

- Step 1** Create a Cisco VSG data port profile and a Cisco VSG-ha port profile by first enabling the Cisco VSG data port-profile configuration mode. Cisco VSG data interface should be in the system VLAN. To configure VSG data interface in the system VLAN, you need a system network segment, a system port-profile, and an uplink configured as a system uplink. Use the **configure** command to enter global configuration mode.

**Important** Ensure that all the critical VMs are configured in the system  
VLANs

```
vsm# configure
```

**Step 2**

Create Network Uplink port-profile and use it in the Logical Switch.

```
vsm(config)# nsm logical network vsm_LogicalNet
vsm(config-logical-net)# exit

vsm(config)# nsm network segment pool vsm_NetworkSite
vsm(config-net-seg-pool)# member-of logical network vsm_LogicalNet
vsm(config-net-seg-pool)# exit

vsm(config)# nsm ip pool template VM_IP_Pool
vsm(config-ip-pool-template)# ip address 10.0.0.2 10.0.0.255
vsm(config-ip-pool-template)# network 255.255.255.0 10.0.0.1
vsm(config-ip-pool-template)# exit

vsm(config)# port-profile type ethernet sys-uplink
vsm(config-port-prof)# channel-group auto
vsm(config-port-prof)# no shutdown
vsm(config-port-prof)# system port-profile
vsm(config-port-prof)# state enabled
vsm(config-port-prof)# exit

vsm(config)# nsm network uplink vsm_Uplink
vsm(config-uplink-net)# allow network segment pool vsm_NetworkSite
vsm(config-uplink-net)# import port-profile sys_Uplink
vsm(config-uplink-net)# system network uplink
vsm(config-uplink-net)# publish uplink-network
vsm(config-uplink-net)# exit
```

**Step 3**

Create the network segment and port-profile for the Data VLAN.

```
vsm(config)# nsm network segment VMAccess_502
vsm(config-net-seg)# member-of network segment pool vsm_NetworkSite
vsm(config-net-seg)# system network segment
vsm(config-net-seg)# switchport access vlan 502
vsm(config-net-seg)# ip pool import template VM_IP_Pool
vsm(config-net-seg)# publish network-segment
vsm(config-net-seg)# exit
vsm(config)# port-profile type vethernet VSG_Data
vsm(config-port-prof)# no shutdown
vsm(config-port-prof)# state enabled
vsm(config-port-prof)# system port-profile
vsm(config-port-prof)# publish port-profile
vsm(config-port-prof)# exit
```

**Step 4**

Create the network segment and port-profile for the HA VLAN.

```
vsm(config)# nsm network segment VMAccess_503
vsm(config-net-seg)# member-of network segment pool vsm_NetworkSite
vsm(config-net-seg)# switchport access vlan 503
vsm(config-net-seg)# ip pool import template VM_IP_Pool
vsm(config-net-seg)# publish network-segment
vsm(config-net-seg)# exit
vsm(config)# port-profile type vethernet VSG_HA
vsm(config-port-prof)# no shutdown
```

```
vsm(config-port-prof)# state enabled
vsm(config-port-prof)# publish port-profile
vsm(config-port-prof)# exit
```

---

## Task 4: On the VSM, Configuring Virtual Network Adapters on the Hosts

Now that you have prepared Cisco VSG port profiles on VSM, you should configure virtual network adapters on the hosts.

This task includes the following subtasks:

- [Create Port-profile for the Virtual Network Adapter, on page 26](#)
- [Creating Virtual Network Adapter, on page 27](#)

### Before You Begin

Ensure that you have:

- Cisco VSG port-profile configured on VSM.

## Create Port-profile for the Virtual Network Adapter

You need to log in to VSM to create port-profile for the virtual network adapter.

### SUMMARY STEPS

1. Create port-profile for the virtual network adapter in VSM.

### DETAILED STEPS

---

Create port-profile for the virtual network adapter in VSM.

#### Example:

```
vsm#configure terminal
vsm(config)#port-profile type vethernet Virtual-Net-PP
vsm(config-port-prof)#capability 13-vservice
vsm(config-port-prof)#no shutdown
vsm(config-port-prof)#state enabled
vsm(config-port-prof)#publish port-profile
vsm(config-port-prof)#exit
vsm#copy running-config startup-config
```

---

## Creating Virtual Network Adapter

### Before You Begin

Make sure that you know the following:

- Port-profile for virtual network adapter is created.

- 
- Step 1** Launch SCVMM.
- Step 2** In the **VMs and Services** tab, click **All Hosts**.
- Step 3** Choose the host on which you want to add the virtual network adapter.
- Step 4** Right-click the host and choose **Properties** from the pop-up menu.
- Step 5** In the **Properties** window, click **Virtual Switches**.
- Step 6** On the **Virtual Switches** tab, click **New Virtual Network Adapter**.
- Step 7** In the **Name** field, enter name of virtual network adapter.
- Step 8** Under the **Connectivity**, in the **VM Network** field, choose an appropriate VM network.
- Step 9** Under **Port profile**, select L3 service enabled port-profile that you created from the **Classification** drop-down list.
- Step 10** Under **IP address configuration**, check **Static** radio-button and do the following:
- a) Choose IP-pool for virtual network adapter from the **IPv4 pool** drop-down list.
  - b) In the **IPv4 address** field, enter IP address for virtual network adapter.
- Step 11** Click **Ok**.
- Step 12** The VM manager warning message appears, click **Ok**.
- 

### What to Do Next

Add a physical router between VSG and virtual network adapter.

## Task 5: Installing Cisco VSG from an ISO Image



---

**Note** Cisco VSG is supported as VSB on Nexus Cloud Services platform only.

---

### Before You Begin

Ensure that you have:

- Installed Microsoft SCVMM SP1 or SCVMM R2.
- Downloaded the Cisco VSG ISO image and uploaded it to the server (C:\ProgramData\Virtual Machine Manager Library Files\ISO). Refresh the library server under the Library tab.
- Cisco VSG-Data port profile: VSG-Data.

- Cisco VSG-ha port profile: VSG-ha.
- HA ID.
- IP/subnet mask/gateway information for Cisco VSG
- Administrator password
- Minimum of 2 GB RAM and 2 GB hard disk space, recommended space is 4 GB RAM and 4 GB hard disk.
- Cisco Prime NSC IP address.
- The shared secret password.
- IP connectivity between Cisco VSG and Cisco Prime NSC is okay.

- Cisco VSG NSC-PA image name (vsghv-pa.2.1.1e.bin) is available.

- Step 1** Launch SCVMM.
- Step 2** On the **VMs and Services** tab, click **Create Virtual Machine**.
- Step 3** In the Create Virtual Machine Wizard, in the **Select Source** screen, check the **Create the new virtual machine with a blank virtual hard disk** radio button, and click **Next**.
- Step 4** In the **Specify Virtual Machine Identity** screen, enter the name for the Cisco VSG in the **Virtual machine name** field and click **Next**.

**Figure 8: Create Virtual Machine Wizard - Specify Virtual Machine Identity**

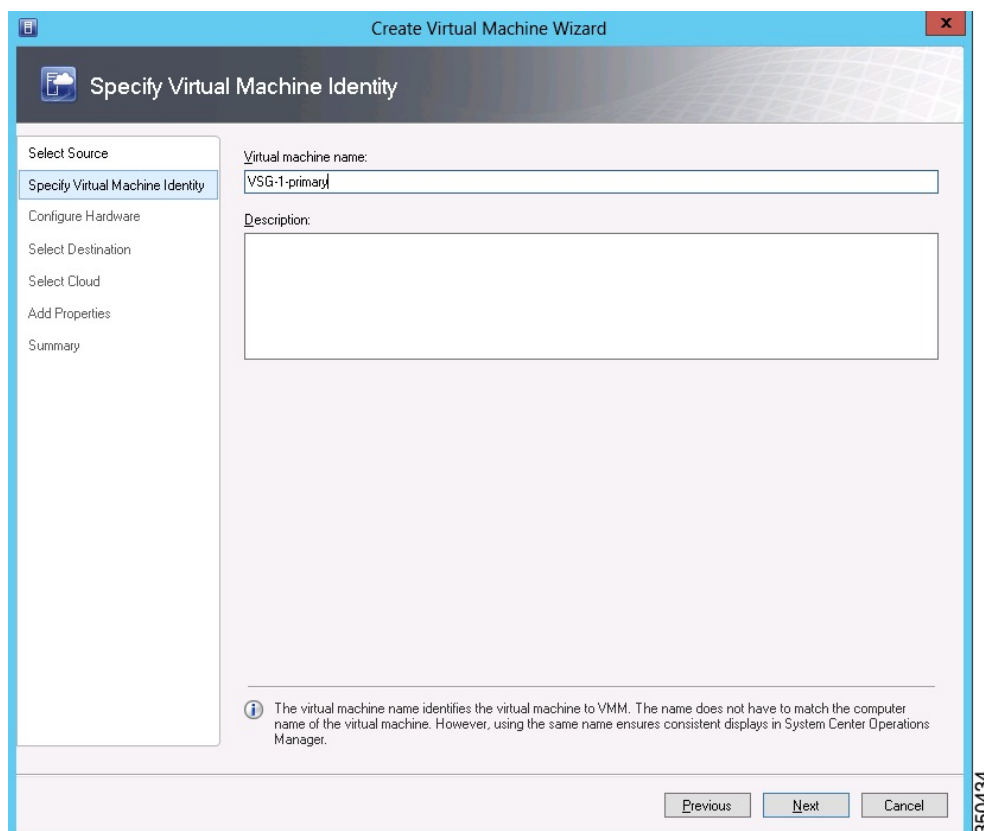

- Step 5** In the **Configure Hardware** section, do the following:
- Under **General**, choose **Memory**, choose the **Static** option, and enter 2048 MB in the **Virtual machine memory** field.
  - Under **Bus Configuration**, choose the primary disk and enter 2 in the **Size (GB)** field.
  - Choose the virtual DVD Drive, select the **Existing ISO image file** radio button and browse for the VSG ISO within the SCVMM Library.
  - Click **New > Network Adapter** to create a total of three new Network Adapters.

- Under the **Network Adapters** section, choose **Network Adapter 1**, and then choose **Connected to a VM network** and browse for the appropriate network that corresponds to the network segment for the VSG's data interface.

**Note** Network Adapter 1 is Service/Data network, use it to connect to the Data network.

**Note** Network Adapter 2 is the management network, connect it to the management network for the VSG.

**Note** Network Adapter 3 is the HA network, connect it to the HA network.

**Figure 9: Create Virtual Machine Wizard - Configure Hardware**

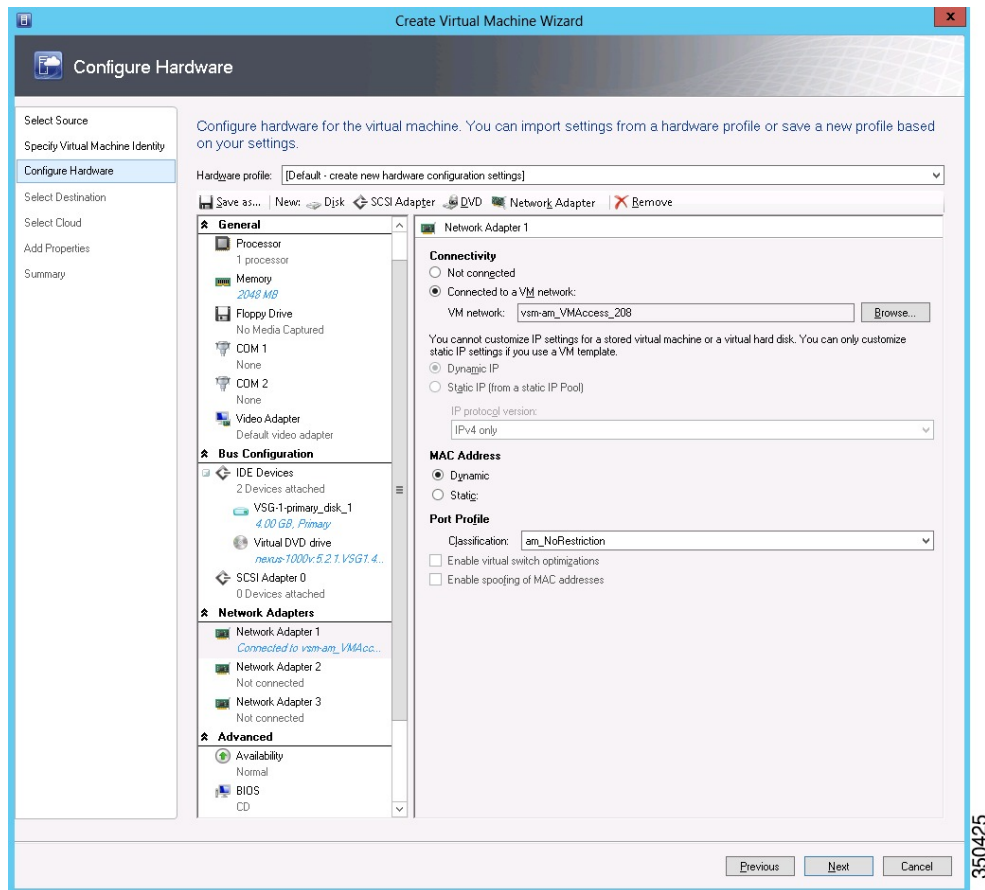

- From the **Classification** drop-down list, choose the port-profile corresponding to the VSG's data interface.

**Note** Repeat Step d to create network adapters for management and HA.



- Step 6** In the **Select Destination** section, choose **Place the virtual machine in a host**, choose the host group on which you want to store the VSG from the drop-down list, and click **Next**.
- Step 7** In the **Select Host** section, choose the host that you want to place the VSG on and click **Next**.
- Step 8** In the **Configure Settings** section, review the virtual machine settings to ensure they are correct, and click **Next**.
- Step 9** (Optional) In the **Add Properties** section, choose the **Other Linux (64-bit) from the Operating System** from the drop-down list, and then click **Next**.
- Step 10** In the **Summary** section, click **Create**.
- Step 11** Once the VSG is successfully installed, choose the VSG on the **VMs and Services** tab, and click **Power On**.
- Step 12** Connect to the VSG using **Connect or View > Connect via Console**.
- 

## Task 6: On the VSG, Configuring the Cisco Prime NSC Policy Agent

Once Cisco Prime NSC is installed, you must register Cisco VSG with Cisco Prime NSC.

### Before You Begin

Ensure that you have:

- The Cisco Prime NSC policy-agent image on Cisco VSG (for example, vsghv-pa.2.1.1.e.bin).



---

**Note** The string **vsghv-pa** must appear in the image name as highlighted.

---

- IP address of the Cisco Prime NSC.
- Shared secret password you defined during the Cisco Prime NSC installation.
- IP connectivity between the VSG and the Cisco Prime NSC.



---

**Note** If you upgrade your VSG, you must also copy the latest Cisco VSG policy agent image. This image is available in Cisco Prime NSC image bundle to boot from a flash drive and to complete registration with Cisco Prime NSC.

---



---

**Note** VSG clock should be synchronized with Cisco Prime NSC clock.

---

## SUMMARY STEPS

1. On Cisco VSG, configure the NSC policy agent:
2. Check the status of the NSC policy agent configuration to verify that you have installed Cisco Prime NSC correctly and it is reachable by entering the **show nsc-pa status** command. This example shows that Cisco Prime NSC is reachable and the installation is correct:

## DETAILED STEPS

**Step 1** On Cisco VSG, configure the NSC policy agent:

```
VSG-Firewall# configure
Enter configuration commands, one per line. End with CNTL/Z.
VSG-Firewall(config)# nsc-policy-agent
VSG-Firewall(config-nsc-policy-agent)# registration-ip 10.193.72.242
VSG-Firewall(config-nsc-policy-agent)# shared-secret Sgate123
VSG-Firewall(config-nsc-policy-agent)# policy-agent-image vnmc-vsgpa.2.1.1b.bin
VSG-Firewall(config-nsc-policy-agent)# copy running-config startup-config
[#####] 100%
Copy complete, now saving to disk (please wait)...
VSG-Firewall(config-nsc-policy-agent)# exit
```

**Step 2** Check the status of the NSC policy agent configuration to verify that you have installed Cisco Prime NSC correctly and it is reachable by entering the **show nsc-pa status** command. This example shows that Cisco Prime NSC is reachable and the installation is correct:

```
VSG-Firewall(config)# show nsc-pa status
NSC Policy-Agent status is - Installed Successfully. Version 2.1(1b)-vsg
Cisco VSG is now registered with Cisco Prime NSC.
```

This example shows that Cisco Prime NSC is unreachable or an incorrect IP is configured:

```
vsg# show nsc-pa status
NSC Policy-Agent status is - Installation Failure
Cisco Prime NSC not reachable.
vsg#
```

This example shows that the NSC policy-agent is not configured or installed:

```
vsg# show nsc-pa status
NSC Policy-Agent status is - Not Installed
```

# Task 7: On Cisco VSG, Cisco VSM, and Cisco Prime NSC, Verifying the NSC Policy-Agent Status

You can use the **show nsc-pa status** command to verify the nsc policy-agent status on Cisco VSG, Cisco VSM, and Cisco Prime NSC (which can indicate that you have installed the policy-agent successfully).

## SUMMARY STEPS

1. Log in to the Cisco VSG.
2. Check the status of NSC-PA configuration by entering the following command:
3. Log in to the Cisco VSM.
4. Check the status of NSC-PA configuration by entering the following command:
5. Log in to Cisco Prime NSC.
6. Click **Resource Management** and then click **Resources**.
7. In the **navigation** pane, click **VSMs** and verify the VSM information in the **VSMs** pane.
8. In the **navigation** pane, click **VSGs** and verify the VSG information in the **VSGs** pane.

## DETAILED STEPS

- 
- Step 1** Log in to the Cisco VSG.
- Step 2** Check the status of NSC-PA configuration by entering the following command:  
vsg# **show nsc-pa status**  
NSC Policy-Agent status is - Installed Successfully. Version 2.0(1a)-vsg  
vsg#
- Step 3** Log in to the Cisco VSM.
- Step 4** Check the status of NSC-PA configuration by entering the following command:  
VSM# **show nsc-pa status**  
NSC Policy-Agent status is - Installed Successfully. Version 2.0(0.22)-vsm  
VSM#
- Step 5** Log in to Cisco Prime NSC.
- Step 6** Click **Resource Management** and then click **Resources**.
- Step 7** In the **navigation** pane, click **VSMs** and verify the VSM information in the **VSMs** pane.
- Step 8** In the **navigation** pane, click **VSGs** and verify the VSG information in the **VSGs** pane.
- 

# Task 8: On Cisco Prime NSC, Configuring a Tenant, Security Profile, Compute Firewall, and Assigning Cisco VSG to the Compute Firewall

Now that you have Cisco Prime NSC and Cisco VSG successfully installed with the basic configurations, you should configure the basic security profiles and policies.

This task includes the following subtasks:

- [Configuring a Tenant on Cisco Prime NSC, on page 34](#)
- [Configuring a Security Profile on the Cisco Prime NSC, on page 34](#)
- [Configuring a Compute Firewall and Assigning Cisco VSG to Cisco Prime NSC, on page 35](#)

**What to Do Next**

Go to [Configuring a Tenant on Cisco Prime NSC](#), on page 34

## Configuring a Tenant on Cisco Prime NSC

Tenants are entities (businesses, agencies, institutions, and so on) whose data and processes are hosted on VMs on the virtual data center. To provide firewall security for each tenant, the tenant must first be configured in Cisco Prime NSC.

### SUMMARY STEPS

1. From the Cisco Prime NSC toolbar, click the **Tenant Management** tab.
2. In the Navigation pane directory tree, right-click **root**, and from the drop-down list, choose **Create Tenant**.
3. In the **Create Tenant** dialog box, do the following:
4. Click **OK**.

### DETAILED STEPS

- 
- Step 1** From the Cisco Prime NSC toolbar, click the **Tenant Management** tab.
- Step 2** In the Navigation pane directory tree, right-click **root**, and from the drop-down list, choose **Create Tenant**.
- Step 3** In the **Create Tenant** dialog box, do the following:
- a) In the **Name** field, enter the tenant name; for example, Tenant-A.
  - b) In the **Description** field, enter a description for that tenant.
- Step 4** Click **OK**.  
Notice that the tenant that you have just created is listed in the left-side pane under root.
- 

**What to Do Next**

See [Configuring a Security Profile on the Cisco Prime NSC](#), on page 34

## Configuring a Security Profile on the Cisco Prime NSC

You can configure a security profile on Cisco Prime NSC.

- 
- Step 1** In the Cisco Prime NSC toolbar, click the **Policy Management**>**Service Profiles**.
- Step 2** In the **Root** navigation window, from the directory path, choose **Tenant > Compute Firewall > Compute Security Profile**.
- Step 3** Right-click **Compute Security Profile** and choose **Add Compute Security Profile**.  
The **Add Compute Security Profile** dialog box opens.
- Step 4** In the **Add Compute Security Profile** dialog box, do the following:

- a) In the **Name** field, enter a name for the security profile; for example, sp-web.
- b) In the **Description** field, enter a brief description of this security profile.

**Step 5** Click **OK**

---

### What to Do Next

See [Configuring a Compute Firewall and Assigning Cisco VSG to Cisco Prime NSC](#), on page 35

## Configuring a Compute Firewall and Assigning Cisco VSG to Cisco Prime NSC

The compute firewall is a logical virtual entity that contains the device profile that you can bind (assign) to Cisco VSG VM. The device policy in the device profile is then pushed from Cisco Prime NSC to Cisco VSG. Once this is complete, the compute firewall is in the applied configuration state on Cisco Prime NSC.

---

- Step 1** From Cisco Prime NSC, choose **Resource Management > Managed Resources**.
  - Step 2** On the left-pane directory tree, navigate to choose a tenant.
  - Step 3** Click the **Action** drop-down list, choose **Add Compute Firewall**. The **Add Compute Firewall** dialog box opens.
  - Step 4** In the **Add Compute Firewall** dialog box, do the following:
    - a) In the **Name** field, enter a name for the compute firewall.
    - b) In the **Description** field, enter a brief description of the compute firewall.
    - c) In the **Host Name** field, enter the name for your Cisco VSG.
  - Step 5** Click **Next**.  
The new Compute Firewall pane displays with the information that you provided.
  - Step 6** In the **Select Service Devices** pane, choose **Assign VSG** radio button, from the **VSG Devices** drop-down, choose a VSG. then and click **Next**.
  - Step 7** In the **Interface** tab, **Configure Data Interface** pane, enter data interface (data0) IP address and subnet mask, and click **Next**.
  - Step 8** Verify the configuration in **Summary** tab and click **Finish**.
  - Step 9** Click **Root > Tenant > Network Services** and verify the status of the firewall.
-

## Task 9: On the Prime NSC, Configuring a Permit-All Rule

You can configure a permit-all rule in the Cisco Prime NSC.

- 
- Step 1** Log in to the Cisco Prime NSC.
- Step 2** Choose **Policy Management > Service Profiles**.
- Step 3** Choose **Root > Tenant > Compute Firewall > Compute Security Profile**, and then select a security profile.
- Step 4** In the right pane, click **Add ACL Policy Set**.
- Step 5** In the **Add ACL Policy** dialog box, do the following:
- In the **Name** field, enter the ACL Policy Set name.
  - In the **Description** field, enter a brief description of the ACL Policy Set.
  - Click **Add ACL Policy**.
- Step 6** In the **Add ACL Policy** dialog-box, enter the policy name, enter policy description, and then click **Add Rule**.
- Step 7** In the **Add Rule** dialog box, do the following:
- In the **Name** field, enter the rule name.
  - For the **Action** radio button, choose the matching condition (for example, Permit-All to permit all the traffic).
  - On the **Condition Match Criteria** field, choose the required condition.
  - On the **Source - Destination - Service** tab, click **Add** to add source/destination conditions or service.
  - On the **Protocol** tab, uncheck **Any** to choose specific protocols. Do not uncheck **Any** if you wish to match all the protocols.
  - On the **Ether-Type** tab, click **Add** to specify an Ether type for the rule.
  - On the **Time Range** tab, keep the default option to leave the rule enabled.
  - On the **Advanced** tab, click **Add** to add checks for source ports.
  - Click **Ok**.
- Step 8** In the **Add Policy** dialog box, click **OK**.  
The newly created policy is displayed in the **Assigned** field.
- Step 9** In the **Add Policy Set** dialog box, click **OK**.
- Step 10** In the **Service Profile** window, click **Save**.
- 

## Task 10: On Cisco VSG, Verifying the Permit-All Rule

You can verify the rule presence in Cisco VSG, by using the Cisco VSG CLI and the **show** commands.

```
vsg# show running-config rule
rule POL-DEMO/R-DEMO@root/Tenant/VDC
cond-match-criteria: match-allaction permit
rule POL1/R1@root/Tenant/VDC
cond-match-criteria: match-allaction permit
rule default/default-rule@root
cond-match-criteria: match-allaction drop
vsg#
```

# Task 11: Enabling Logging

To enable logging follow these procedures:

- [Enabling Logging level 6 for Policy-Engine Logging](#), on page 37
- [Enabling Global Policy-Engine Logging](#), on page 38

## Enabling Logging level 6 for Policy-Engine Logging

Logging enables you to see what traffic is going through your monitored virtual machine. This logging is helpful for verifying that you have a proper configuration and to help in troubleshooting. You can enable Logging Level 6 for policy-engine logging in a monitor session.

**Step 1** Log in to Cisco Prime NSC.

**Step 2** Choose **Policy Management > Device Configurations**.

**Step 3** In the **Navigation** pane, choose **root > Policies > Syslog > Default**, and then click **Edit**.

**Step 4** In the **Edit Syslog** dialog box, do the following:

- Click the **Servers** tab.
- In the **Server Type** column, choose the **primary** server type from the displayed list.
- From the pane toolbar, click **Edit**.

**Figure 10: Edit Syslog Dialog Box**

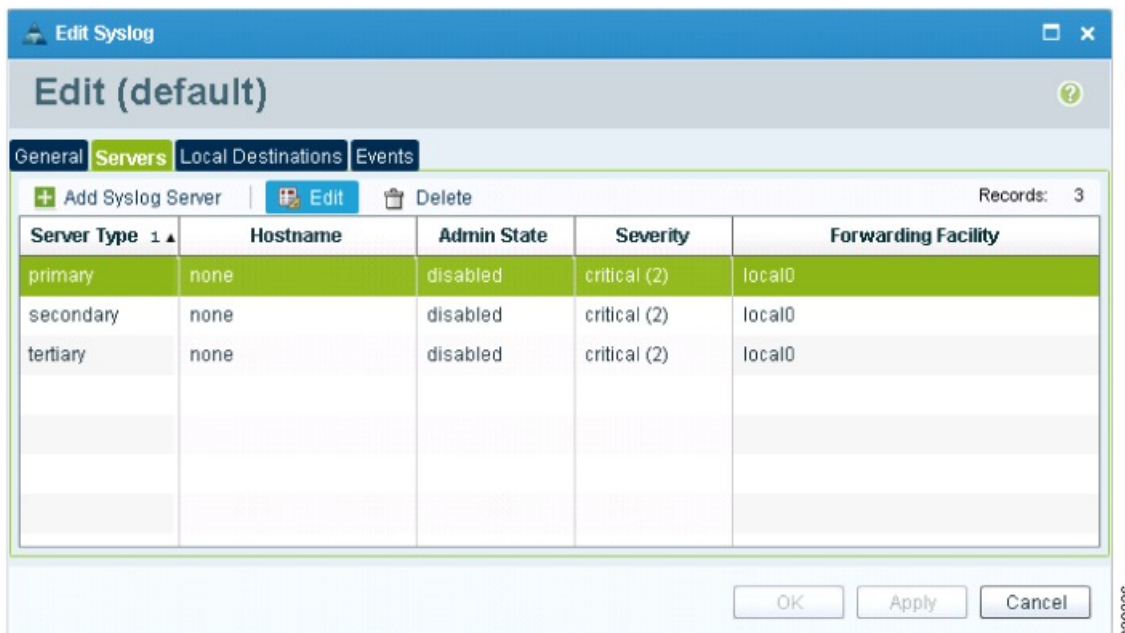

- Step 5** In the **Edit Syslog Client** dialog box, do the following:
- In the **Hostname/IP address** field, enter the syslog server IP address.
  - From the **Severity** drop-down list, choose **Information(6)**.
  - From the **Admin State** drop-down list, check **Enabled** radio button.
  - Click **OK**.
- Step 6** Click **OK**.

---

### What to Do Next

See [Enabling Global Policy-Engine Logging](#), on page 38.

## Enabling Global Policy-Engine Logging

Logging enables you to see what traffic is going through your monitored VM. This logging is helpful for verifying that you have a proper configuration and to help in troubleshooting.

- Step 1** Log in to Cisco Prime NSC.
- Step 2** In the **Cisco Prime NSC** window, choose **Policy Management > Device Configurations > root > Device Profiles > default**. The **default** Device Profile window opens.
- Step 3** In the **default** pane, do the following:
- In the **Work** pane, click the **Policies**.
  - In the **Policy Engine Logging** field, check the **Enabled** radio button.
- Step 4** Click **Save**.

## Task 12: Enabling the Traffic VM Port-Profile for Firewall Protection and Verifying the Communication Between the VSM, VEM, and VSG

This section includes the following topics:

- [Enabling Traffic VM Port-Profile for Firewall Protection](#), on page 39
- [Verifying the VSM or VEM for Cisco VSG Reachability](#), on page 40
- [Checking the VM Virtual Ethernet Port for Firewall Protection](#), on page 41

### Before You Begin

Ensure that you have:



- Server VM that runs with an access port profile (for example, web server)
- Cisco VSG data IP address (for example, 10.10.10.200) and VLAN ID (for example, 100)
- Set up the Virtual Network Adapter
- Security profile name (for example, sp-web)
- Organization (Org) name (for example, root/Tenant-A)
- Port profile that you would like to edit to enable firewall protection

## Enabling Traffic VM Port-Profile for Firewall Protection

You can enable a traffic VM port profile for traffic protection.

### SUMMARY STEPS

1. Create VSG node.
2. Create the network segment and Traffic VM Port-Profile for Firewall Protection.

### DETAILED STEPS

#### Step 1

Create VSG node.

```
vsm#configure terminal
vsm (config)# vservice node VSG type vsg
vsm (config-vservice-node)# ip address 10.10.10.200
vsm (config-vservice-node)# adjacency 13
vsm (config-vservice-node)# exit
vsm (config)# copy running-config startup-config
```

#### Step 2

Create the network segment and Traffic VM Port-Profile for Firewall Protection.

```
vsm(config)# nsm network segment VMAccess_400
vsm(config-net-seg)# member-of network segment pool vsm_NetworkSite
vsm(config-net-seg)# switchport access vlan 400
vsm(config-net-seg)# ip pool import template VM_IP_Pool
vsm(config-net-seg)# publish network-segment
vsm(config-net-seg)# exit
```

```
vsm(config)# port-profile type vethernet pp-webserver
vsm(config-port-prof)# org root/Tenant-A
vsm(config-port-prof)# vservice node VSG profile sp-web
vsm(config-port-prof)# no shutdown
vsm(config-port-prof)# state enabled
vsm(config-port-prof)# publish port-profile
vsm(config-port-prof)# exit
vsm(config)# show port-profile name pp-webserver
```

### What to Do Next

See [Verifying the VSM or VEM for Cisco VSG Reachability](#), on page 40.

## Verifying the VSM or VEM for Cisco VSG Reachability

Ensure that you have assigned the traffic VM port profile with firewall protection to the traffic VM.

**Figure 11: Virtual Machine Properties Window**

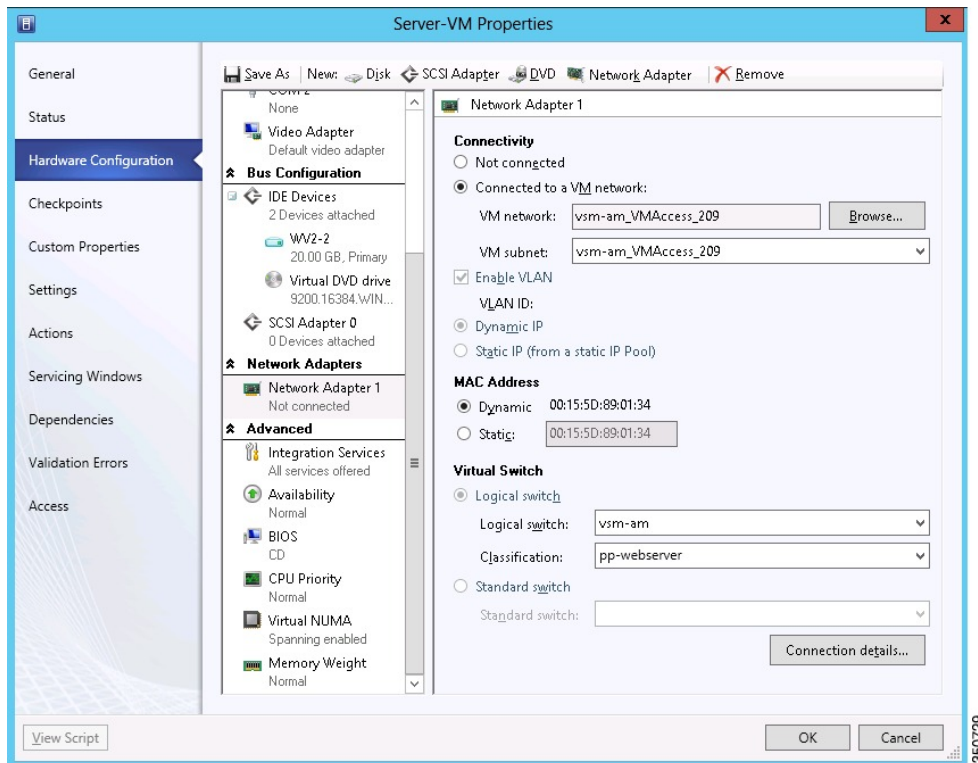

This example shows how to verify the communication between the VEM and the VSG:

```
VSM# show vservice brief
```

```
-----
Node Information
-----
ID Name          Type   IP-Address   Mode   State   Module
1 VSG-1          vsg    192.161.0.85  13     Alive   3, 4,
-----
Path Information
-----
Port Information
-----
PortProfile:PP-VSERVICE
Org:root/Tenant1
Node:VSG-1 (192.161.0.85)
Veth Mod VM-Name          Profile (Id) :SP1 (6)
      4  4 traffic-vm-win-22  vNIC IP-Address
      8  3 traffic-vm-win-12  192.163.0.53,
     10  3 traffic-vm-ubuntu-61 192.163.0.76
     11  3 traffic-vm-ubuntu-52 192.163.0.80,
                          192.163.0.52,
```

A display showing the IP-ADDR Listing and Alive state verifies that the VEM can communicate with the Cisco VSG.

## Checking the VM Virtual Ethernet Port for Firewall Protection

This example shows how to verify the VM Virtual Ethernet port for firewall protection:

```
VSM(config)# show vservice port brief port-profile VSGDemo-WEB-FW
-----
Port Information
-----
PortProfile:VSGDemo-WEB-FW
Org:root/Demo
Node:VSG(153.1.1.13)
Veth Mod VM-Name
1 3 web-server1
Profile(Id):Demo-Default-Security-Profile(6)
vNIC IP-Address
152.1.1.11,
```



**Note** Make sure that your VNSP ID value is greater than 1.

## Task 13: Installing Microsoft Service Provider Foundation

After installing Cisco Prime NSC, you need to enable communication between the Prime NSC and Microsoft SCVMM. This is required for virtual machine attribute based policies to work on VSG. Microsoft Service Provider Foundation (SPF) is a plugin that enables communication between Microsoft SCVMM and Cisco Prime NSC. The following table lists the SPF versions compatible with Cisco Prime NSC 3.2:

**Table 1: SPF versions compatible with Cisco Prime NSC 3.2**

SCVMM Version	SPF Version
System Center 2012 Service Pack 1	7.1.3117.0
System Center 2012 R2	7.2.379.0

This task includes the following subtasks:

- [Installing Service Provider Foundation, on page 41](#)
- [Configuring Service Provider Foundation, on page 42](#)
- [Verifying Service Provider Foundation Installation, on page 42](#)
- [Creating VM Manager on Cisco Prime NSC, on page 42](#)

### What to Do Next

See [Installing Service Provider Foundation, on page 41](#)

## Installing Service Provider Foundation

For detailed information about installing Service Provider Foundation, see *How to Install Service Provider Foundation for System Center 2012 R2* available at: <http://technet.microsoft.com/en-us/library/dn266007.aspx>

**Before You Begin**

Ensure that you have:

- Downloaded install system center 2012 R2 orchestrator.
- Verified the system requirements for Service Provider Foundation (SPF). For information on system requirements, refer to *System Requirements for Service Provider Foundation for System Center 2012 SPI*, available at: <http://technet.microsoft.com/en-us/library/jj642899.aspx>.
- NTP server information.

**Configuring Service Provider Foundation**

After the Service Provider Foundation (SPF) is successfully installed, you need to create a stamp ID (stampId) and associate it with the Microsoft SCVMM server. For more information about configuring SPF, see <http://technet.microsoft.com/en-us/library/jj613915.aspx>.

**What to Do Next**

See [Verifying Service Provider Foundation Installation](#), on page 42

**Verifying Service Provider Foundation Installation**

To check if the SPF installation is successful and functional, launch the following VMM REST interface web link:

```
https://<spf_host>:8090/SC2012R2/VMM/Microsoft.Management.Odata.Svc
```

where <spf\_host> is the IP address for the Microsoft SCVMM VM.

Use the following link to launch the Virtual Machines REST URL:

```
https://<spf_host>:8090/SC2012R2/VMM/Microsoft.Management.Odata.Svc/VirtualMachines
```

where <spf\_host> is the IP address for the SCVMM VM.

**Creating VM Manager on Cisco Prime NSC**

You need to create a VM manager to enable Prime NSC to retrieve VM information from Microsoft SCVMM.

- 
- Step 1** Launch Cisco Prime NSC.
- Step 2** Choose **Resource Management > VM Manager > Add VM Manager**.
- Step 3** In the **Add VM Manager** dialog box, enter the following:
- Name for VM manager.
  - Description for the VM manager
  - Hostname/IP address of SCVMM.
  - Domain-Name/User-name.
  - Password SCVMM host.
  - Keep the default Port Number.

g) Click **OK**.

---

## Task 14: Sending Traffic Flow and on Cisco VSG Verifying Statistics and Logs

This section includes the following topics:

- [Sending Traffic Flow](#), on page 44
- [Verifying Policy-Engine Statistics and Logs on Cisco VSG](#), on page 45

## Sending Traffic Flow

You can send traffic flow through the Cisco VSG to ensure that it is functioning properly.

**Step 1** Ensure that you have the VM (Server-VM) that is using the port profile (pp-webserver) configured for firewall protection.

**Figure 12: Virtual Machine Properties Window**

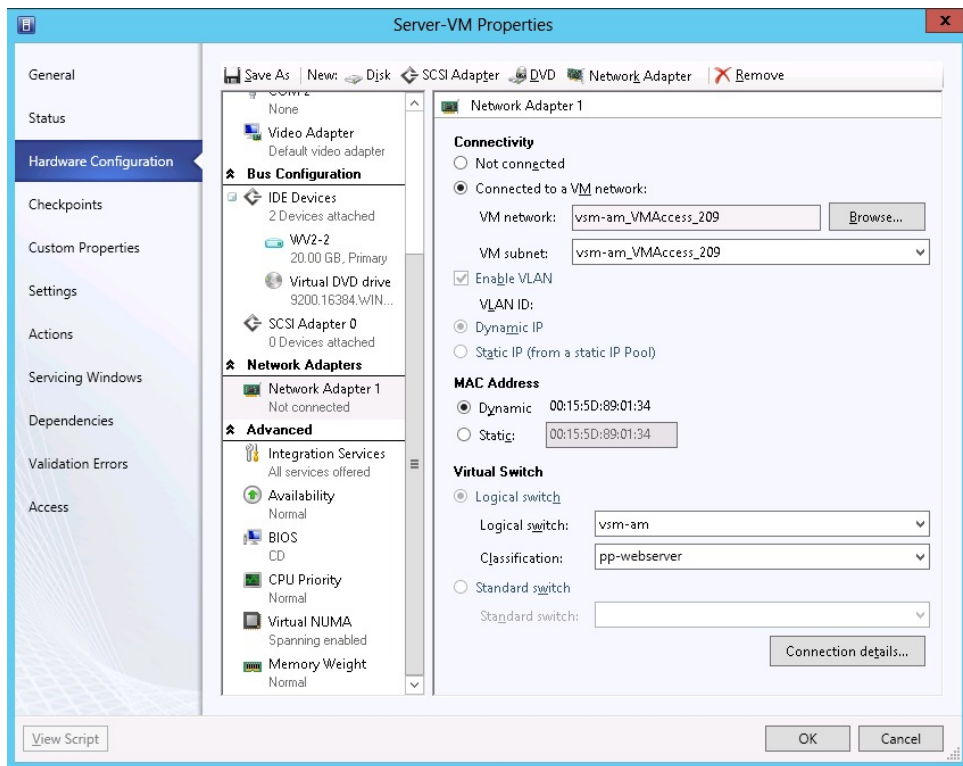

**Step 2** Log in to any of your client virtual machine (Client-VM).

**Step 3** Send traffic (for example, HTTP) to your Server-VM.

```
[root@]# wget http://172.31.2.92/
--2010-11-28 13:38:40-- http://172.31.2.92/
Connecting to 172.31.2.92:80... connected.
HTTP request sent, awaiting response... 200 OK
Length: 258 [text/html]
Saving to: `index.html'

100% [=====>] 258      --.-K/s
   in 0s

2010-11-28 13:38:40 (16.4 MB/s) - `index.html' saved [258/258]
```

```
[root]#
```

**Step 4** Check the policy-engine statistics and log in to Cisco VSG.

---

### What to Do Next

See [Verifying Policy-Engine Statistics and Logs on Cisco VSG](#), on page 45.

## Verifying Policy-Engine Statistics and Logs on Cisco VSG

Log in to Cisco VSG and check the policy-engine statistics and logs.

This example shows how to check the policy-engine statistics and logs:

```
vsg# show policy-engine stats
Policy Match Stats:
default@root          :          0
  default/default-rule@root :      0 (Drop)
  NOT_APPLICABLE       :          0 (Drop)

PS_web@root/Tenant-A :          1
  pol_web/permit-all@root/Tenant-A :      1 (Log, Permit)
  NOT_APPLICABLE       :          0 (Drop)

vsg# terminal monitor
vsg# 2010 Nov 28 05:41:27 firewall %POLICY_ENGINE-6-POLICY_LOOKUP_EVENT:
policy=PS_web@root/Tenant-A rule=pol_web/permit-all@root/Tenant-A action=Permit
direction=egress src.net.ip-address=172.31.2.91 src.net.port=48278
dst.net.ip-address=172.31.2.92 dst.net.port=80 net.protocol=6 net.ethertype=800
```







# Installing the Cisco Prime Network Services Controller

This chapter contains the following sections:

- [Information About the Cisco Prime NSC](#) , page 47
- [Installation Requirements](#), page 47
- [Microsoft Hyper-V Server Requirement](#), page 52
- [Installing Cisco Prime NSC](#), page 52

## Information About the Cisco Prime NSC

The Cisco Prime Network Services Controller (Cisco Prime NSC) is a virtual appliance that provides centralized device and security policy management for Cisco virtual services. Designed to support enterprise and multiple-tenant cloud deployments, the Cisco Prime NSC provides transparent, seamless, and scalable management for securing virtualized data center and cloud environments.

## Installation Requirements

### Cisco Prime NSC System Requirements

Requirement	Description
<b>Virtual Appliance</b>	
Four virtual CPUs	1.8 GHz each
Memory	Minimum 4 GB RAM, recommended 4 GB RAM

Requirement	Description
Disk space	Without InterCloud functionality, 40 GB on shared NFS or SAN, and configured on two disks as follows: <ul style="list-style-type: none"> <li>• Disk 1: 20 GB</li> <li>• Disk 2: 20 GB</li> </ul>
Management interface	One management network interface
Processor	x86 Intel or AMD server with 64-bit processor
<b>Microsoft Hyper-V</b>	
Microsoft SCVMM 2012 SP1 or SCVMM 2012 R2	
<b>Interfaces and Protocols</b>	
HTTP/HTTPS	—
Lightweight Directory Access Protocol (LDAP)	—
<b>Intel VT</b>	
Intel Virtualization Technology (VT)	Enabled in the BIOS

## Web-Based GUI Client Requirements

Requirement	Description
Operating system	Any of the following: <ul style="list-style-type: none"> <li>• Windows</li> <li>• Apple Mac OS</li> </ul>

Requirement	Description
Browser	<p>Any of the following:</p> <ul style="list-style-type: none"> <li>• Internet Explorer 9.0</li> <li>• Mozilla Firefox 23.0</li> <li>• Chrome 29.0</li> </ul> <p><b>Note</b> If you are running Firefox or IE and do not have Flash, or you have a version of Flash that is older than 11.2, a message displays asking you to install Flash and provides a link to the Adobe website.</p> <p><b>Note</b> Before using Google Chrome with Cisco Prime NSC, you must disable the Adobe Flash Players that are installed by default with Chrome. For more information, see <i>Configuring Chrome for Use with Cisco Prime NSC</i>.</p>
Flash Player	Adobe Flash Player plugin (Version 11.2 or higher)



**Note** Before you can use Chrome with Prime NSC 3.2, you must first disable the Adobe Flash Players that are installed by default with Chrome.

## Firewall Ports Requiring Access

Requirement	Description
80	HTTP/TCP
443	HTTP
843	TCP

## Cisco Nexus 1000V Series Switch Requirements

Requirement	Notes
General	

Requirement	Notes
The procedures in this guide assume that the Cisco Nexus 1000V Series switch is up and running, and that endpoint Virtual Machines (VMs) are installed.	—
<b>Port Profiles</b>	
One port profile configured on the Cisco Nexus 1000V Series Switch for the service VLAN.	—

## Information Required for Installation and Configuration

Information Type	Your Information
<b>For Deploying the Cisco Prime NSC ISO</b>	
Name	
ISO file location	
Storage location	
Management port profile name for VM management <b>Note</b> The management port profile is the same port profile that is used for VSM. The port profile is configured in VSM and is used for the Cisco Prime NSC management interface.	
IP address	
Subnet mask	
Gateway IP address	
Domain name	
DNS server	
Admin password	
Shared secret password for communications between the Cisco Prime NSC, Cisco VSG, and VSM.	
<b>For Configuring Microsoft Hyper-V in Cisco Prime NSC</b>	
HyperV name	
Description	

Information Type	Your Information
Hostname or IP address	

## Shared Secret Password Criteria

A shared secret password is a password that is known only to those using a secure communication. Passwords are designated strong if they cannot be easily guessed for unauthorized access. When you set a shared secret password for communications between the Cisco Prime NSC, Cisco VSG, and VSM, adhere to the following criteria for setting valid, strong passwords:

Do not include the following items in passwords:

- Characters: & ' " ` ( ) < > | \ ; \$
- Spaces

Create strong passwords based on the characteristics in this table:

**Table 2: Characteristics of Strong Passwords**

Strong passwords have...	Strong passwords do not have...
<ul style="list-style-type: none"> <li>• At least eight characters.</li> <li>• Lowercase letters, uppercase letters, digits, and special characters.</li> </ul>	<ul style="list-style-type: none"> <li>• Consecutive characters, such as <i>abcd</i>.</li> <li>• Characters repeated three or more times, such as <i>aaabbb</i>.</li> <li>• A variation of the word <i>Cisco</i>, such as <i>cisco</i>, <i>ocsic</i>, or one that changes the capitalization of letters in the word <i>Cisco</i>.</li> <li>• The username or the username in reverse.</li> <li>• A permutation of characters present in the username or <i>Cisco</i>.</li> </ul>

Examples of strong passwords are:

- If2CoM18
- 2004AsdfLkj30
- Cb1955S21

## Microsoft Hyper-V Server Requirement

You must set the clock to the correct time on all the Microsoft Hyper-V servers that will run Cisco Prime NSC, Cisco VSG, or VSM. If you do not set the correct time on the server, the Cisco Prime NSC CA certificate that is created when the Cisco Prime NSC VM is deployed might have an invalid time stamp.

After you set the clock to the correct time on all the Hyper-V servers that run the Cisco Prime NSC, you can, as an option, set the clock on the Cisco Prime NSC as follows:

- If you set the clock manually, be sure to enter the correct time zone as a Coordinated Universal Time (UTC) offset.
- If you set the clock by synchronizing with the Network Time Protocol (NTP), you can select the UTC time zone.

## Installing Cisco Prime NSC

### Before You Begin

- Verify that the Hyper-V host on which to deploy the Cisco Prime NSC VM is available in SCVMM.
- Copy the Cisco Prime NSC ISO image to the SCVMM library location on the file system. To make this image available in SCVMM, choose **Library > Library Servers**, right-click the library location, and then refresh.
- Set your keyboard to United State English before installing the Cisco Prime NSC and using the VM console.
- There is no dependency on the VM hardware version, so the VM hardware version can be upgraded if required.

- 
- Step 1** Launch the SCVMM.
- Step 2** Choose the Hyper-V host on which to deploy the Cisco Prime NSC VM.
- Step 3** Right-click the Hyper-V host and choose **Create Virtual Machine**.
- Step 4** In the **Create Virtual Machine** wizard, from the **Select Source** screen, choose the **Create the new virtual machine with a blank virtual hard disk** radio button, then click **Next**.
- Step 5** In the **Specify Virtual Machine Identity** screen, provide the required information, then click **Next**.
- Step 6** In the **Configure Hardware** screen, do the following:
- a) From **General**, do the following:
    - Choose **Processor** and choose the number of processors.
    - Choose **Memory** and choose the required memory value. You will need a minimum 4 GB of memory for Prime NSC.
  - b) From **Bus Configuration > IDE Devices**, do the following:
    - Choose **Hard Disk**, enter the required size of the hard disk. You will need a minimum of 20 GB of hard disk.

- Choose **Virtual DVD Drive**, check the **Existing ISO image file** radio button, and browse to choose the Cisco Prime NSC 3.2 ISO image file.

- Choose **Network Adapters > Network Adapter 1**, check the **Connect to a VM Network** radio button, and browse to choose a VM Network.
- Click **Next**.

**Step 7** In the **Select Destination** screen, do the following:

- Check the **Place the virtual machine on a host** radio button.
- Choose **All hosts** from the **Destination** drop-down list.
- Click **Next**.

**Step 8** In the **Select Host** screen, choose the destination, then click **Next**.

**Step 9** In the **Configure Settings** screen, review the virtual machine settings, then click **Next**.

**Step 10** In the **Add properties** screen, choose the **Red Hat Enterprise Linux 5 (64 bit)** operating system, then click **Next**.

**Step 11** In the **Summary** screen, do the following:

- Verify the settings.
- Check the **Start the virtual machine after deploying it** check box.
- Click **Create**.

The job Create virtual machine starts. You can see the status of this job in The Recent Jobs window. Ensure that the job completes without any errors.

**Step 12** After the virtual machine is successfully created, right-click the new Virtual Machine (vnmc21-perf in this case) and choose **Connect or View > Connect Via Console**.

**Step 13** Launch the console and install Cisco Prime NSC.

**Note** Before the final Cisco Prime NSC installation step, before you reboot, launch Microsoft SCVMM again, right-click the Virtual machine (vnmc21-hyperv in this case), and choose **Properties > Hardware Configuration > Bus Configuration > Virtual DVD Drive > no media** so that Cisco Prime NSC does not use the ISO image at boot time.

**Step 14** After Cisco Prime NSC is successfully deployed, click **Close** and power on the Cisco Prime NSC VM.

---







## Installing the Cisco VSG

---

This chapter contains the following sections:

- [Information About the Cisco VSG, page 55](#)
- [Prerequisites for Installing the Cisco VSG Software, page 57](#)
- [Obtaining the Cisco VSG Software, page 57](#)
- [Installing the Cisco VSG Software, page 57](#)
- [Configuring Initial Settings, page 60](#)
- [Verifying the Cisco VSG Configuration, page 63](#)
- [Where to Go Next, page 63](#)

### Information About the Cisco VSG

This section describes how to install and complete the basic configuration of the Cisco VSG for Cisco Nexus 1000v Series switch software.

- [Host and VM Requirements, on page 55](#)
- [Cisco VSG and Supported Cisco Nexus 1000V Series Device Terminology, on page 56](#)

### Host and VM Requirements

The Cisco VSG has the following requirements:

- Microsoft SCVMM SP1 or SCVMM R2
- Virtual Machine (VM)
  - 64-bit VM is required.
  - 1 processor
  - 2 GB RAM

- 3 NICs
- Minimum 2 GB hard disk with LSI Logic Parallel adapter (default)
- Minimum CPU speed of 1 GHz

## Cisco VSG and Supported Cisco Nexus 1000V Series Device Terminology

This table lists the terminology used in the Cisco VSG implementation.

Term	Description
Logical Switch	Logical switch that spans one or more servers. It is controlled by one VSM instance.
NIC	Network interface card.
Server hosting SCVMM	Service that acts as a central administrator for Microsoft Hyper-V hosts that are connected on a network. The server directs actions on the VMs and the VM hosts.
Virtual Ethernet Module (VEM)	Part of the Cisco Nexus 1000V Series switch that switches data traffic. It runs on a Microsoft Hyper-V host. Up to 64 VEMs are controlled by one VSM. All the VEMs that form a switch domain should be in the same virtual data center as defined by the Hyper-V server.
Virtual Machine (VM)	Virtualized x86 PC environment in which a guest operating system and associated application software can run. Multiple VMs can operate on the same host system concurrently.
vPath	Component in the Cisco Nexus 1000V Series switch with a VEM that directs the appropriate traffic to the Cisco VSG for policy evaluation. It also acts as fast path and can short circuit part of the traffic without sending it to the Cisco VSG.
Virtual Security Gateway (VSG)	Cisco software that secures virtual networks and provides firewall functions in virtual environments using the Cisco Nexus 1000V Series switch by providing network segmentation.
Virtual Supervisor Module (VSM)	Control software for the Cisco Nexus 1000V Series distributed virtual device that runs on a Virtual Machine (VM) and is based on Cisco NX-OS.
SCVMM	System Center Virtual Machine Manager Connect remotely to Hyper-V server. It is the primary interface for creating, managing, and monitoring VMs, their resources, and their hosts. It also provides console access to VMs.

## Prerequisites for Installing the Cisco VSG Software

The following components must be installed and configured:

- On the Cisco Nexus 1000V Series switch, configure two port profiles for the Cisco VSG: one for the service VLAN and the other for the HA VLAN. (You will be configuring the Cisco VSG IP address on the Cisco VSG so that the Cisco Nexus 1000V Series switch can communicate with it.)

Details about configuring VLANs and port profiles on the Cisco Nexus 1000V Series switch are available in the Cisco Nexus 1000V Series switch documentation.

## Obtaining the Cisco VSG Software

You can obtain the Cisco VSG software files at this URL:

<http://software.cisco.com/download/navigator.html>

## Installing the Cisco VSG Software

You can install the Cisco VSG software on a VM by using an ISO image file from the CD.

## Installing the Cisco VSG Software from an ISO File

### Before You Begin

Ensure that you have:

- Installed Microsoft SCVMM 2012 SP1 or SCVMM 2012 R2.
- Downloaded the Cisco VSG ISO image and uploaded it to the server (C:\ProgramData\Virtual Machine Manager Library Files\ISO). Refresh the library server under the Library tab.
- Cisco VSG-Data port profile: VSG-Data.
- Cisco VSG-ha port profile: VSG-ha.
- HA ID.
- IP/subnet mask/gateway information for the Cisco VSG.
- Admin password.
- 2 GB RAM and 2 GB hard disk space.
- Cisco Prime NSC IP address.
- The shared secret password.
- IP connectivity between Cisco VSG and Cisco Prime NSC.

- Cisco VSG NSC-PA image name (vsghv-pa.2.1.1.e.bin).

- Step 1** Launch SCVMM.
- Step 2** On the **VMs and Services** tab, click **Create Virtual Machine**.
- Step 3** In the **Create Virtual Machine Wizard**, in the **Select Source** screen, check **Create the new virtual machine with a blank virtual hard disk** radio button, and click **Next**.
- Step 4** In the **Specify Virtual Machine Identity** screen, enter the name for the Cisco VSG in the **Virtual machine name** field, and click **Next**.

**Figure 13: Create Virtual Machine Wizard - Specify Virtual Machine Identity**

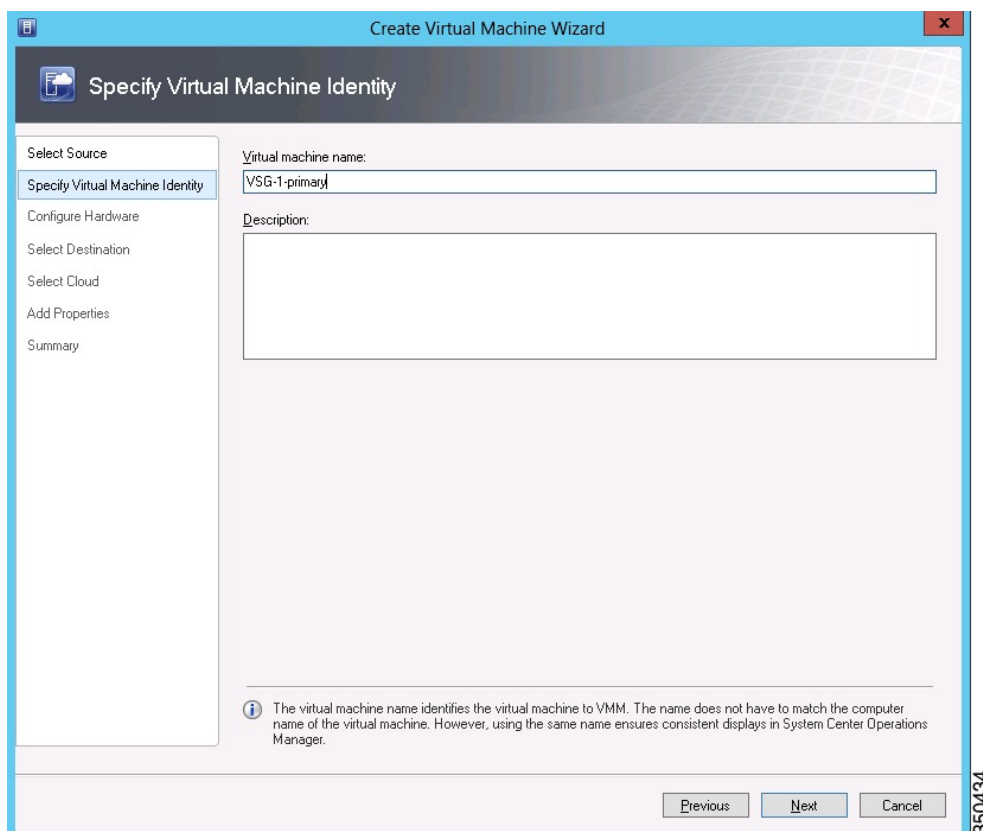

- Step 5** In the **Configure Hardware** section, do the following:
- Under **General**, choose **Memory**, choose the **Static** option, and enter 2048 MB in the **Virtual machine memory** field.
  - Under **Bus Configuration**, choose the primary disk and enter 2 in the Size (GB) field.
  - Choose the virtual DVD Drive, select the **Existing ISO image file** radio button and browse for the VSG ISO within the SCVMM Library.
  - Choose the **Network Adapter** drop-down near the top of the Create Virtual Machine Wizard and create two new Network Adapters.

- Under the **Network Adapters** section, choose **Network Adapter 1**, then choose **Connected to a VM network** and browse for the appropriate network corresponding to the network segment for the VSG's data interface.
- From the **Classification** drop-down list, choose the port-profile corresponding to the VSG's data interface.

**Note** Repeat Step d to create network adapters for service interface.

**Step 6** In the **Select Destination** section, choose **Place the virtual machine in a host** and choose the host group on which you want to store the VSG from the drop-down and click **Next**.

**Step 7** In the **Select Host** section, select the host that you want to place the VSG on and click **Next**.

**Figure 14: Create Virtual Machine Wizard - Select Host**

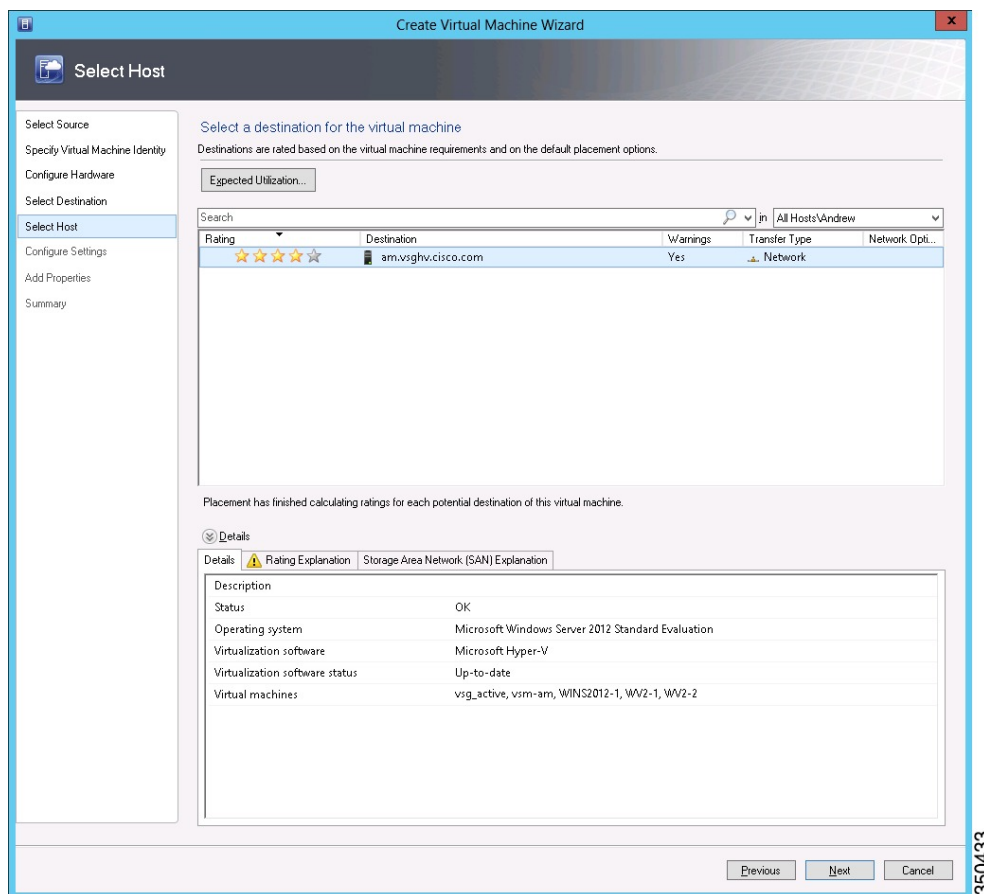

**Step 8** In the **Configure Settings** section, review the virtual machine settings to ensure they are correct and click **Next**.

**Step 9** (Optional) In the **Add Properties** section, choose **Other Linux (64-bit) from the Operating System** drop-down list, and then click **Next**.

**Step 10** In the **Summary** section, click **Create**.

**Step 11** Choose the VSG in the **VMs and Services** tab and click **Power On**.

**Step 12** Connect to the VSG using **Connect or View -> Connect via Console**.

## Configuring Initial Settings

This section describes how to configure the initial settings on Cisco VSG and configure a standby Cisco VSG with its initial settings. For configuring a standby Cisco VSG, see [Configuring Initial Settings on a Secondary Cisco VSG, on page 63](#) section.

You can connect to a VSG VM console through the SCVMM user interface by right-clicking a VM instance and connecting to it.

- 
- Step 1** Navigate to the **Console** tab in the VM.  
The Cisco Nexus 1000V Series switch opens the **Console** window and boots the Cisco VSG software.
- Step 2** At the `Enter the password for "admin"` prompt, enter the password for the admin account and press **Enter**.
- Step 3** At the prompt, confirm the admin password and press **Enter**.
- Step 4** At the `Enter HA role[standalone/primary/secondary]` prompt, enter the HA role that you want to use and press **Enter**.  
This can be one of the following:
- standalone
  - primary
  - secondary
- Step 5** At the `Enter the ha id(1-1024)` prompt, enter the HA ID for the pair and press **Enter**.  
**Note** If you entered secondary in the earlier step, the HA ID for this system must be the same as the HA ID for the primary system.
- Step 6** If you want to perform basic system configuration, at the `Would you like to enter the basic configuration dialog (yes/no)` prompt, enter **yes** and press **Enter**, then complete the following steps.
- a) At the `Create another login account (yes/no) [n]` prompt, do one of the following:
- To create a second login account, enter **yes** and press **Enter**.
  - Press **Enter**.
- b) (Optional) At the `Configure read-only SNMP community string (yes/no) [n]` prompt, do one of the following:
- To create an SNMP community string, enter **yes** and press **Enter**.
  - Press **Enter**.

c) At the Enter the Virtual Security Gateway (VSG) name prompt, enter **VSG-demo** and press **Enter**.

- Step 7** At the Continue with Out-of-band (mgmt0) management configuration? (yes/no) [y]: prompt, enter **yes** and press **Enter**.
- Step 8** At the Mgmt IPv4 address: prompt, enter **10.10.10.11** and press **Enter**.
- Step 9** At the Mgmt IPv4 netmask prompt, enter **255.255.255.0** and press **Enter**.
- Step 10** At the Configure the default gateway? (yes/no) [y] prompt, enter **yes** and press **Enter**.
- Step 11** At the Enable the telnet service? (yes/no) [y]: prompt, enter **no** and press **Enter**.
- Step 12** At the Configure the ntp server? (yes/no) [n] prompt, enter **NTP server** information and press **Enter**.  
The following configuration will be applied:
- ```
Interface mgmt0
ip address 10.10.10.11 255.255.255.0
no shutdown
vrf context management
ip route 0.0.0.0/10.10.11.1
no telnet server enable
ssh key rsa 768 force
ssh server enable
feature http-server
ha-pair id 25
```
- Step 13** At the Would you like to edit the configuration? (yes/no) [n] prompt, enter **n** and press **Enter**.
- Step 14** At the Use this configuration and save it? (yes/no) [y]: prompt, enter **y** and press **Enter**.
- Step 15** At the VSG login prompt, enter the name of the admin account you want to use and press **Enter**.  
The default account name is admin.
- Step 16** At the Password prompt, enter the name of the password for the admin account and press **Enter**.  
You are now at the Cisco VSG node.

## On the VSG, Configuring the Cisco Prime NSC Policy Agent

Once the Cisco Prime NSC is installed, you must register the VSG with the Cisco Prime NSC.



### Note

Cisco VSG is supported as VSB on Nexus Cloud Services platform only.

### Before You Begin

Make sure that you know the following:

- The Cisco Prime NSC policy-agent image is available on the VSG (for example, vsghv-pa.2.1.1a.bin)



### Note

The string **vsghv-pa** must appear in the image name as highlighted.

- The IP address of the Cisco Prime NSC.
- The shared secret password you defined during the Cisco Prime NSC installation.
- That IP connectivity between the VSG and the Cisco Prime NSC is working.



**Note** If you upgrade your VSG, you must also copy the latest Cisco VSG policy agent image. This image is available in the Cisco Prime NSC image bundle to boot from a flash drive and to complete registration with the Cisco Prime NSC.



**Note** VSG clock should be synchronized with the Cisco Prime NSC clock.

### Step 1 On the VSG, enter the following commands:

```
VSG-Firewall# configure terminal
Enter configuration commands, one per line. End with CNTL/Z.
VSG-Firewall(config)# nsc-policy-agent
VSG-Firewall(config-nsc-policy-agent)# registration-ip 10.193.72.242
VSG-Firewall(config-nsc-policy-agent)# shared-secret Sgate123
VSG-Firewall(config-nsc-policy-agent)# policy-agent-image vnmc-vsgpa.2.1.1b.bin
VSG-Firewall(config-nsc-policy-agent)# copy running-config startup-config
[#####] 100%
Copy complete, now saving to disk (please wait)...
VSG-Firewall(config-nsc-policy-agent)# exit
```

### Step 2 Check the status of the NSC policy agent configuration to verify that you have installed the Cisco Prime NSC correctly and it is reachable by entering the **show nsc-pa status** command. This example shows that the Cisco Prime NSC is reachable and the installation is correct:

```
VSG-Firewall(config)# show nsc-pa status
NSC Policy-Agent status is - Installed Successfully. Version 2.1(1b)-vsg
The VSG is now registered with the Cisco Prime NSC.
```

This example shows that the Cisco Prime NSC is unreachable or an incorrect IP is configured:

```
vsg# show nsc-pa status
NSC Policy-Agent status is - Installation Failure
Cisco Prime NSC not reachable.
vsg#
```

This example shows that the NSC policy-agent is not configured or installed:

```
vsg# show nsc-pa status
NSC Policy-Agent status is - Not Installed
```



## Configuring Initial Settings on a Secondary Cisco VSG

You can configure a standby Cisco VSG by logging in to the Cisco VSG you have identified as secondary and using the following procedure to configure a secondary Cisco VSG with its initial settings.

- 
- Step 1** Navigate to the **Console** tab in the VM.  
Cisco Nexus 1000V Series switch opens the **Console** window and boots the Cisco VSG software.
- Step 2** At the `Enter the password for "admin"` prompt, enter the password for the admin account and press **Enter**.
- Step 3** At the prompt, confirm the admin password and press **Enter**.
- Step 4** At the `Enter HA role[standalone/primary/secondary]` prompt, enter the secondary HA role and press **Enter**.
- Step 5** At the `Enter the ha id(1-1024)` prompt, enter **25** for the HA pair Id and press **Enter**.  
**Note** The HA ID uniquely identifies the two Cisco VSGs in an HA pair. If you are configuring Cisco VSGs in an HA pair, make sure that the ID number you provide is identical to the other Cisco VSG in the pair.
- Step 6** At the `VSG login` prompt, enter the name of the admin account you want to use and press **Enter**.  
The default account name is `admin`.
- Step 7** At the `Password` prompt, enter the name of the password for the admin account and press **Enter**.  
You are now at the Cisco VSG node.
- 

## Verifying the Cisco VSG Configuration

To display the Cisco VSG configuration, perform this task:

| Command                           | Purpose                                            |
|-----------------------------------|----------------------------------------------------|
| <code>show interface brief</code> | Displays a brief status and interface information. |

This example shows how to verify the Cisco VSG configurations:

```
vsg# show interface brief
-----
Port      VRF      Status IP Address      Speed  MTU
-----
mgmt0    --      up      10.193.77.217   1000   1500
```

## Where to Go Next

After installing and completing the initial configuration of the Cisco VSG, you can configure firewall policies on the Cisco VSG through the Cisco Prime NSC.





## Registering Devices with the Cisco Prime NSC

This chapter contains the following sections:

- [Registering a Cisco VSG, page 65](#)
- [Registering Cisco Nexus 1000V VSM, page 66](#)

### Registering a Cisco VSG

You can register Cisco VSG with Cisco Prime NSC. Registration enables communication between the Cisco VSG and the Cisco Prime NSC.

- 
- Step 1** Copy the vsghv-pa.2.1.1e.bin file into the Cisco VSG bootflash:  
vsg# `copy ftp://guest@172.18.217.188/n1kv/vsghv-pa.2.1.1e.bin bootflash`
- Step 2** Enter global configuration mode.  
vsg# `configure`
- Step 3** Enter nsc-policy-agent mode.  
vsg (config)# `nsc-policy-agent`
- Step 4** Set the Cisco Prime NSC registration IP address.  
vsg (config-nsc-policy-agent)# `registration-ip 209.165.200.225`
- Step 5** Specify the shared-secret of Cisco Prime NSC.  
vsg (config-nsc-policy-agent)#  
`shared-secret *****`
- Step 6** Install the policy agent.  
vsg (config-nsc-policy-agent)#  
`policy-agent-image bootflash: vsghv-pa.2.1.1e.bin`
- Step 7** Exit all modes.  
vsg (config-nsc-policy-agent)# `end`
- Step 8** On the Cisco VSG command line, display the NSC PA status:  
vsg# `show nsc-pa status`  
If registration was successful, you should see the following message:  
"NSC Policy-Agent status is - Installed Successfully. Version 2.1(1a)-vsg"  
The Cisco VSG registration is complete.

**Step 9** Copy the running configuration to the startup configuration:

```
vsg# copy running-config startup-config
```

Executing this command ensures that the registration becomes part of the basic configuration

## Registering Cisco Nexus 1000V VSM

You can register Cisco Nexus 1000V with Cisco Prime NSC. Registration enables communication between the Cisco Nexus 1000V VSM and Cisco Prime NSC.

### SUMMARY STEPS

1. Copy the vsmhv-pa.3.2.1c.bin file into the VSM bootflash:
2. Enter global configuration mode.
3. Enter config nsc-policy-agent mode.
4. Set the Cisco Prime NSC registration IP address.
5. Specify the shared-secret of Cisco Prime NSC.
6. Install the policy agent.
7. Exit all modes.
8. Display the NSC PA status:
9. Copy the running configuration to the startup configuration:

### DETAILED STEPS

- Step 1** Copy the vsmhv-pa.3.2.1c.bin file into the VSM bootflash:
- ```
vsm# copy ftp://guest@172.18.217.188/nlkv/vsmhv-pa.3.2.1c.bin bootflash:
```
- Step 2** Enter global configuration mode.
- ```
vsg# configure
```
- Step 3** Enter config nsc-policy-agent mode.
- ```
vsg(config)# nsc-policy-agent
```
- Step 4** Set the Cisco Prime NSC registration IP address.
- ```
vsg(config-nsc-policy-agent)# registration-ip 209.165.200.226
```
- Step 5** Specify the shared-secret of Cisco Prime NSC.
- ```
vsg(config-nsc-policy-agent)# shared-secret *****
```
- Step 6** Install the policy agent.
- ```
vsg(config-nsc-policy-agent)# policy-agent-image bootflash:vsmhv-pa.3.2.1c.bin
```
- Step 7** Exit all modes.
- ```
vsg(config-nsc-policy-agent)# top
```
- Step 8** Display the NSC PA status:
- ```
vsg# show nsc-pa status
```
- If registration was successful, you should see the following message:  
NSC Policy-Agent status is - Installed Successfully. Version 2.1(1a)-vsg  
The Cisco Nexus 1000V VSM registration is complete.

**Step 9** Copy the running configuration to the startup configuration:

```
vsg# copy running-config startup-config
```

Executing this command ensures that the registration becomes part of the basic configuration.

---

**What to Do Next**

See the *Cisco Virtual Management Center CLI Configuration Guide* for detailed information about configuring the Cisco Prime NSC using the CLI.





## CHAPTER 6

# Installing the Cisco VSG on a Cisco Cloud Service Platform Virtual Services Appliance

---

This chapter contains the following sections:

- [Information About Installing the Cisco VSG on the Cisco Cloud Service Platform, page 69](#)
- [Prerequisites for Installing Cisco VSG on the Cisco Cloud Service Platform, page 70](#)
- [Guidelines and Limitations, page 70](#)
- [Installing Cisco VSG on a Cisco Cloud Service Platform, page 71](#)

## Information About Installing the Cisco VSG on the Cisco Cloud Service Platform

The Cisco VSG software is provided with the other virtual service blade (VSB) software in the Cisco Cloud Service Platform bootflash: repository directory. The Cisco Cloud Service Platform has up to six virtual

service blades (VSBs) on which you can choose to place a Cisco VSG, VSM, or Network Analysis Module (NAM).

**Figure 15: Cisco Cloud Service Platform Architecture Showing Virtual service Blades Usage**

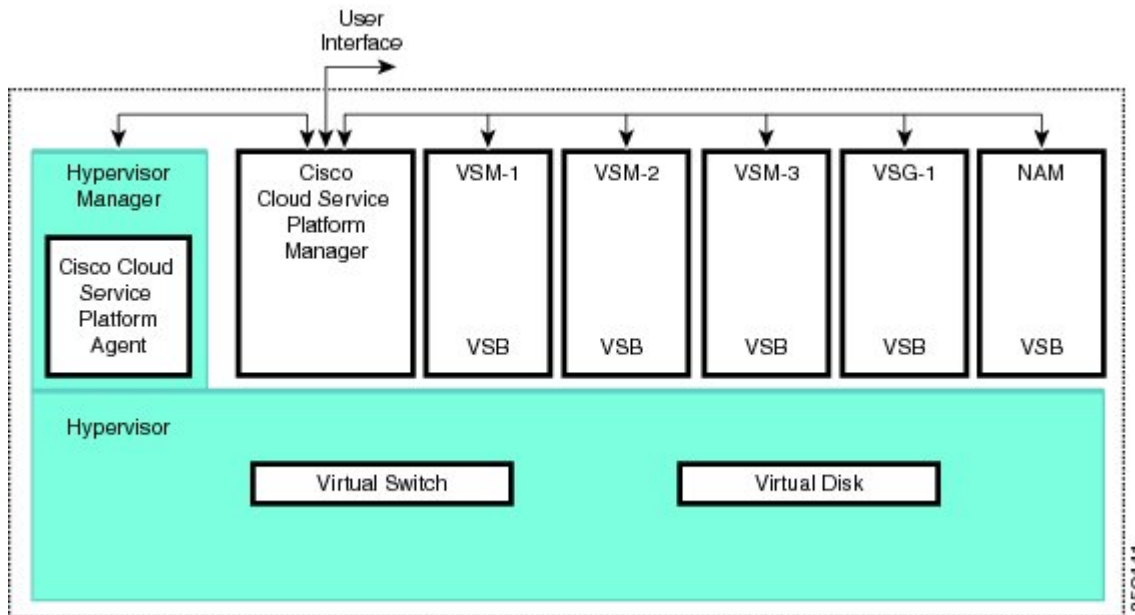

## Prerequisites for Installing Cisco VSG on the Cisco Cloud Service Platform

- You must first install the Cisco Cloud Service Platform Virtual Services Appliance and connect it to the network. For procedures on installing the hardware, see the *Cisco Cloud Service Platform Virtual Services Appliance Hardware Installation Guide*.
- After you install the hardware appliance and connect it to the network, you can configure the Cisco Cloud Service Platform management software and create and configure new VSBs that might host the Cisco VSG. For procedures on configuring the software, see the *Cisco Cloud Service Platform Software Configuration Guide*.

## Guidelines and Limitations

- The Cisco Cloud Service Platform appliance and its hosted Cisco VSG VSBs must share the same management VLAN.
- Unlike the data and high availability (HA) VLANs that are set when a Cisco VSG VSB is created, a Cisco VSG VSB inherits its management VLAN from the Cisco Cloud Service Platform.



**Caution**

Do not change the management VLAN on a VSB. Because the management VLAN is inherited from the Cisco Cloud Service Platform, any changes to the management VLAN are applied to both the Cisco Cloud Service Platform and all of its hosted VSBs.

## Installing Cisco VSG on a Cisco Cloud Service Platform

You can install the Cisco VSG on a Cisco Cloud Service Platform as a virtual service blade (VSB).

### Before You Begin

- Log in to the CLI in EXEC mode.
- Know the name of the Cisco VSG VSB that you want to create.
- Whether you are using a new ISO file from the bootflash repository folder or from an existing VSB, do one of the following:
  - If you are using a new ISO file in the bootflash repository, you know the filename, for example, nexus-1000v.5.2.1.VSG2.1.1a.iso
  - If you are using an ISO file from an existing VSB, you must know the name of the VSB type. This procedure includes information about identifying this name.
- Know the following properties for the Cisco VSG VSB:
  - HA ID Management IP address
  - Cisco VSG name
  - Management subnet mask length
  - Default gateway IPv4 address
  - Administrator password
  - Data and HA VLAN IDs
- This procedure shows you how to identify and assign data and HA VLANs for the Cisco VSG VSB. Do not assign a management VLAN because the management VLAN is inherited from the Cisco Cloud Service Platform.

## SUMMARY STEPS

1. switch# **configure terminal**
2. (config)# **virtual-service-blade** *name*
3. (config-vsbs-config)# **description** *description*
4. (config-vsbs-config)# **virtual-service-blade-type** [**name** *name* | **new iso file name**]
5. (config-vsbs-config)# **interface** *name* **vlan** *vlanid*
6. (config-vsbs-config)# **no shutdown**
7. (config-vsbs-config)# **interface** *name* **vlan** *vlanid*
8. (config-vsbs-config)# **enable** [**primary** | **secondary**]
9. (config-vsbs-config)# **show virtual-service-blade** *name name*
10. (Optional) (config-vsbs-config)# **copy running-config startup-config**

## DETAILED STEPS

- 
- Step 1** switch# **configure terminal**  
Enters global configuration mode.
- Step 2** (config)# **virtual-service-blade** *name*  
Creates the named VSB and places you in to configuration mode for that service. The name can be an alphanumeric string of up to 80 characters.
- Step 3** (config-vsbs-config)# **description** *description*  
(Optional) Adds a description to the Cisco VSG VSB.  
The *description* is an alphanumeric string of up to 80 characters.
- Step 4** (config-vsbs-config)# **virtual-service-blade-type** [**name** *name* | **new iso file name**]  
Specifies the type and name of the software image file to add to this Cisco VSG VSB:
- Use the **new** keyword to specify the name of the new Cisco VSG ISO software image file in the bootflash repository folder.
  - Use the **name** keyword to specify the name of the existing Cisco VSG VSB type. Enter the name of an existing type found in the command output.
- Step 5** (config-vsbs-config)# **interface** *name* **vlan** *vlanid*  
Applies the interface and VLAN ID to this Cisco VSG. Use the interface names from the command output.
- Note** If you try to apply an interface that is not present, the following error is displayed:  
ERROR: Interface name not found in the associated virtual-service-blade type.
- Caution** Do not assign a management VLAN. Unlike data and HA VLANs, the management VLAN is inherited from the Cisco Cloud Service Platform.
- Caution** To prevent loss of connectivity, you must configure the same data and HA VLANs on the hosted Cisco VSGs.
- Step 6** (config-vsbs-config)# **no shutdown**  
Enables the interface.
- Step 7** (config-vsbs-config)# **interface** *name* **vlan** *vlanid*  
Applies the interface and VLAN ID to this Cisco VSG. Use the interface names from the command output.

**Note** If you try to apply an interface that is not present, the following error is displayed:

ERROR: Interface name not found in the associated virtual-service-blade type.

**Caution** Do not assign a management VLAN. Unlike data and HA VLANs, the management VLAN is inherited from the Cisco Cloud Service Platform.

**Caution** To prevent loss of connectivity, you must configure the same data and HA VLANs on the hosted Cisco VSGs.

**Step 8** (config-vs-b-config)# **enable [primary | secondary]**

Initiates the configuration of the VSB and then enables it.

If you enter the **enable** command without the optional **primary** or **secondary** keywords, it enables both.

If you are deploying a redundant pair, you do not need to specify primary or secondary.

If you are enabling a nonredundant VSB, you can specify its HA role as follows:

- Use the **primary** keyword to designate the VSB in a primary role.
- Use the **secondary** keyword to designate the VSB in a secondary role.

The Cisco Cloud Service platform prompts you for the following:

- HA ID
- Management IP address
- Management subnet mask length
- Default gateway IPv4 address
- Cisco VSG name
- Administrator password

**Step 9** (config-vs-b-config)# **show virtual-service-blade name name**

(Optional) Displays the new VSB for verification.

While the Cisco Cloud Service Platform management software is configuring the Cisco VSG, the output for this command progresses from in progress to powered on.

**Step 10** (Optional) (config-vs-b-config)# **copy running-config startup-config**

Saves the running configuration persistently through reboots and restarts by copying it to the startup configuration.

This example shows how to configure a Cisco Cloud Service Platform appliance VSB as a Cisco VSG:

```
csp# configure
Enter configuration commands, one per line. End with CNTL/Z.
N1010-63(config)# virtual-service-blade vsg-1
N1010-63(config)# description vsg-1 for Tenant1
N1010-63(config-vs-b-config)# virtual-service-blade-type new nexus-1000v.5.2.1.VSG2.1.1a.iso
N1010-63(config-vs-b-config)# interface data vlan 923
N1010-63(config-vs-b-config)# interface ha vlan 930
N1010-63(config-vs-b-config)# no shutdown
N1010-63(config-vs-b-config)# enable
Enter vsb image: [nexus-1000v.5.2.1.VSG2.1.1a.iso]
Enter HA id[1-4095]: 1002
Management IP version [V4/V6]: [V4]
Enter Management IP address: 10.2.71.117
Enter Management subnet mask: 255.255.255.0
IPv4 address of the default gateway: 10.2.0.1
```

```

Enter HostName: VSG-1
Enter the password for 'admin': Hello123
N1010-63(config-vsbs-config)#exit
N1010-63)#

```

This example show how to install the Cisco VSG on a Cisco Cloud Service Platform as a VSB.

```

N1010-63# configure
N1010-63(config)# virtual-service-blade vsg-1
N1010-63(config-vsbs-config)# show virtual-service-blade-type summary
-----
Virtual-Service-Blade-Type      Virtual-Service-Blade
-----
VSG-1.2                          VSG-NH-hpv
                                   hyperv-soak
                                   VSG-354
                                   VSG-357
                                   vsg-1

N1010-63(config-vsbs-config)# virtual-service-blade-type new nexus-1000v.5.2.1.VSG2.1.1a.iso
or
N1010-63(config-vsbs-config)# show virtual-service-blade name vsg-1

N1010-63(config-vsbs-config)# description vsg-1 for Tenant1
N1010-63(config-vsbs-config)# show virtual-service-blade name vsg-1
-----
virtual-service-blade vsm2
Description:
Slot id: 2
Host Name:
Management IP:
VSB Type Name : VSG-1.0
Interface: ha vlan: 0
Interface: management vlan: 231
Interface: data vlan: 0
Interface: internal vlan: NA
Ramsize: 2048
Disksize: 3
Heartbeat: 0
HA Admin role: Primary
HA Oper role: NONE
Status: VSB NOT PRESENT
Location: PRIMARY
SW version:
HA Admin role: Secondary
HA Oper role: NONE
Status: VSB NOT PRESENT
Location: SECONDARY
SW version:
VSB Info:
-----
N1010-63(config-vsbs-config)# interface data vlan 1044
or
N1010-63(config-vsbs-config)# interface ha vlan 1045

N1010-63(config-vsbs-config)# enable
-----
Enter domain id[1-1024]: 1014
Enter Management IP address: 10.78.108.40
Enter Management subnet mask length 28
IPv4 address of the default gateway: 10.78.108.117
Enter Switchname: VSG-1
Enter the password for 'admin': Hello_123
-----
N1010-63(config-vsbs-config)# show virtual-service-blade name vsg-1
Description:
Slot id:      4
Host Name:    VSG-Fire-hpv
Management IP: 10.78.108.40
VSB Type Name : VSG-1.2

```

```

Configured vCPU:          1
Operational vCPU:        1
Configured Ramsize:      2048
Operational Ramsize:     2048
Disksize:                 3
Heartbeat:                521511

```

```
Legends:  P - Passthrough
```

```

-----
Interface                Type          MAC           VLAN   State  Uplink-Int
                        Pri  Sec Oper  Adm
-----
VsbEthernet4/1          data 0002.3d70.3f0c 1044   up    up Po3   Po3
VsbEthernet4/2  management 0002.3d70.3f0b 231    up    up Po1   Po1
VsbEthernet4/3          ha 0002.3d70.3f0d 1045   up    up Po2   Po2
      internal      NA      NA      NA      up    up
HA Role: Primary
  HA Status: ACTIVE
  Status:      VSB POWERED ON
  Location:    PRIMARY
  SW version:  5.2(1)VSG2(1.1)
HA Role: Secondary
  HA Status: STANDBY
  Status:      VSB POWERED ON
  Location:    SECONDARY
  SW version:  5.2(1)VSG2(1.1)
VSB Info:
  Domain ID : 1054
-----

```

```
N1010-63(config-vsbs-config)# copy running-config startup-config
```

This example shows how to display a virtual service blade summary on the Cisco Cloud Service Platform:

```
N1010-63(config-vsbs-config)# show virtual-service-blade summary
```

```

-----
Name                    HA-Role    HA-Status   Status                Location
-----
VSG-NH-hpv             PRIMARY    ACTIVE      VSB POWERED ON       PRIMARY
VSG-NH-hpv             SECONDARY  STANDBY     VSB POWERED ON       SECONDARY
hyperv-soak            PRIMARY    NONE        VSB NOT PRESENT      PRIMARY
hyperv-soak            SECONDARY  NONE        VSB NOT PRESENT      SECONDARY
VSG-354                PRIMARY    ACTIVE      VSB POWERED ON       PRIMARY
VSG-354                SECONDARY  STANDBY     VSB POWERED ON       SECONDARY
VSG-1                  PRIMARY    ACTIVE      VSB POWERED ON       PRIMARY
VSG-1                  SECONDARY  STANDBY     VSB POWERED ON       SECONDARY
-----

```





# Upgrading the Cisco VSG and the Cisco Prime NSC

This chapter contains the following sections:

- [Complete Upgrade Procedure](#), page 77
- [Upgrade Guidelines and Limitations](#), page 78
- [Upgrade Procedure for Cisco VSG Release 5.2\(1\)VSG1\(4.1\) to Release 5.2\(1\)VSG2\(1.1a\), Cisco VNMC Release 2.1 to Cisco Prime NSC Release 3.2 and Cisco Nexus 1000V Release 5.2\(1\)SM1\(5.1\) to Release 5.2\(1\)SM1\(5.2\)](#), page 79

## Complete Upgrade Procedure

*Table 3: Refer to the Section in Table Based on your Pre-upgrade Product Release*

| You are Upgrading From                                                                                                  | Follow The Sequential Steps in the Following Section:                                                                                                                                                                                                   |
|-------------------------------------------------------------------------------------------------------------------------|---------------------------------------------------------------------------------------------------------------------------------------------------------------------------------------------------------------------------------------------------------|
| Cisco VSG Release 5.2(1)VSG1(4.1) to Release 5.2(1)VSG2(1.1a) and Cisco VNMC Release 2.1 to Cisco Prime NSC Release 3.2 | Upgrade Procedures for Cisco VSG Release 5.2(1)VSG1(4.1) to Release 5.2(1)VSG2(1.1a) and Cisco VNMC 2.1 to Cisco Prime NSC Release 3.2.<br><br>This includes upgrade procedures for Cisco Nexus 1000V Release 5.2(1)SM1(5.1) to Release 5.2(1)SM1(5.2). |

To upgrade the Cisco Prime NSC, Cisco VSG, and Cisco Nexus 1000V, follow the steps sequentially:

- 1 Stage 1: Upgrading Cisco Prime NSC
- 2 Stage 2: Upgrading a Cisco VSG Pair
- 3 Stage 3: Upgrading the VSM pair and the VEMs

**Note**

We highly recommend that you upgrade the Cisco VSG and the Cisco Prime NSC in the sequence listed. Any deviation from the ordered steps could cause disruption of your connectivity and data communication. The Cisco Prime NSC must be upgraded with the corresponding policy agent (PA).

## Information About Cisco Prime NSC Upgrades

When you upgrade the Cisco Prime NSC software, all current (command-line interface) CLI and (graphical user interface) GUI sessions are interrupted, which means that you must restart any CLI or GUI sessions.

## Information About Cisco VSG Upgrades

The upgrade procedure for a standalone Cisco VSG is hitful, which means that you must manually reload the Cisco VSG for the new image to become effective. In HA mode, the upgrade is hitless, which means that the standby Cisco VSG is upgraded first and then after a switchover, the previously active Cisco VSG is upgraded.

Because license information is not stored with the Cisco VSG but is maintained between the Virtual Supervisor Module (VSM) and Virtual Ethernet Module (VEM), if packets are received at the Cisco VSG, that means that the license is valid and the packets are processed.

An upgrade affects two bin files: the kickstart file and the system file.

An upgrade does not erase any of the existing information, when the Cisco VSG comes online. Because the Cisco VSG is stateless, it gets all this information from the Cisco Prime NSC at bootup.

## Upgrade Guidelines and Limitations

Before upgrading the Cisco Prime NSC, Cisco VSG, and Cisco Nexus 1000V, read the following:

- We highly recommend that you upgrade the Cisco VSG and the Cisco Prime NSC in the order provided. Any deviation from the ordered steps could cause disruption of your connectivity and data communication. The Cisco Prime NSC must be upgraded with the corresponding policy agent (PA).
- Before upgrading to a new VSG version with VSG Universal License (UL), make sure that you change VSM mode to advanced and save the configuration. Installing VSG with UL without changing the VSM mode to advanced may cause VSG service failure.
- We recommend that you take a snapshot or backup (clone) of the original Cisco Prime NSC and VSM prior to the upgrade process and then perform an ISSU upgrade process on both the VSM and the Cisco VSG. We do not recommend that you perform a manual upgrade.
- For a full In-service Software Upgrade (ISSU) upgrade on both the Cisco VSG and VSM, follow these rules:
  - Install the Cisco Prime NSC before installing the Cisco VSG and VSM. The ISSU upgrade installs a new PA.
  - A new PA with an old Cisco Prime NSC is not supported and there should never be an interim stage in this state.
  - A copy run start is not required after the VSM upgrade.



- Upgrade instructions include the following information:
  - Different stages of complete upgrade procedures and operations which are supported at different stages.
  - Different component versions after each stage.
  - Different operations supported after each stage.

## Upgrade Procedure for Cisco VSG Release 5.2(1)VSG1(4.1) to Release 5.2(1)VSG2(1.1a), Cisco VNMC Release 2.1 to Cisco Prime NSC Release 3.2 and Cisco Nexus 1000V Release 5.2(1)SM1(5.1) to Release 5.2(1)SM1(5.2)

### Cisco VSG Release 5.2(1)VSG1(4.1) to 5.2(1)VSG2(1.1a) and Cisco VNMC 2.1 to Cisco Prime NSC 3.0.2 to Cisco Prime NSC 3.2 Staged Upgrade

| Virtual Appliance | Original State            | Stage 1: Cisco Prime NSC Upgrade only (no PAs upgraded) | Stage 2: Cisco VSG Upgrade | Stage 3: VSM/VEM Upgrade  |
|-------------------|---------------------------|---------------------------------------------------------|----------------------------|---------------------------|
| Cisco Prime NSC   | Old Cisco VNMC 2.1        | New Cisco Prime NSC 3.0.2                               | New Cisco Prime NSC 3.0.2  | New Cisco Prime NSC 3.0.2 |
|                   | New Cisco Prime NSC 3.0.2 | New Cisco Prime NSC 3.2                                 | New Cisco Prime NSC 3.2    | New Cisco Prime NSC 3.2   |
| Cisco VSG         | Old 5.2(1)VSG1(4.1)       | Old 5.2(1)VSG1(4.1)                                     | New 5.2(1)VSG2(1.1a)       | New 5.2(1)VSG2(1.1a)      |
| VSG PA            | Old 2.0                   | Old 2.0                                                 | New 2.1                    | New 2.1                   |
| VSM               | Old 5.2(1)SM1(5.1)        | Old 5.2(1)SM1(5.1)                                      | Old 5.2(1)SM1(5.1)         | New 5.2(1)SM1(5.2)        |
| VEM               | Old 4.2(1)SV1(5.2b)       | Old 4.2(1)SV1(5.2b)                                     | Old 4.2(1)SV1(5.2b)        | New 4.2(1)SV2(2.1)        |
| VSM PA            | Old 2.0                   | Old 2.0                                                 | Old 2.0                    | New 3.2                   |

| Virtual Appliance                                  | Original State           | Stage 1: Cisco Prime NSC Upgrade only (no PAs upgraded)                                                                                                                                                                          | Stage 2: Cisco VSG Upgrade                                                                                                                                                                                                             | Stage 3: VSM/VEM Upgrade                                                                                                                                                                                                                                                                                                    |
|----------------------------------------------------|--------------------------|----------------------------------------------------------------------------------------------------------------------------------------------------------------------------------------------------------------------------------|----------------------------------------------------------------------------------------------------------------------------------------------------------------------------------------------------------------------------------------|-----------------------------------------------------------------------------------------------------------------------------------------------------------------------------------------------------------------------------------------------------------------------------------------------------------------------------|
| Supported operations after upgrading to each stage | All operations supported | <ul style="list-style-type: none"> <li>• Existing data sessions (offloaded).</li> <li>• New data sessions.</li> <li>• Allows Cisco Nexus 1000V switch (non-vservice) operations including non-vservice port profiles.</li> </ul> | <ul style="list-style-type: none"> <li>• Short disruption in new data session establishment during the Cisco VSG upgrade.</li> <li>• Other operations are fully supported.</li> <li>• Full Layer 3 VSG and VM VLAN support.</li> </ul> | <ul style="list-style-type: none"> <li>• All operations are supported if all the upgrades including VEMs are successful.</li> <li>• Restricted operations (below) apply only if all VEMs are not upgraded</li> <li>• Disruption of data traffic during VEM upgrades.</li> <li>• Layer 3 VSG and VM VLAN support.</li> </ul> |

| Virtual Appliance                                   | Original State | Stage 1: Cisco Prime NSC Upgrade only (no PAs upgraded)                                                                                                                                                                                                                                                                                                                                                                                                                                                                                                                                             | Stage 2: Cisco VSG Upgrade                                                                                                                                                                                                                                                                                                                                                                                                                                                                                                                                                                           | Stage 3: VSM/VEM Upgrade                                                                                                                                                                                                                                                                                                                                                                                                                                                                                                                                                                                                                                                                                                                                       |
|-----------------------------------------------------|----------------|-----------------------------------------------------------------------------------------------------------------------------------------------------------------------------------------------------------------------------------------------------------------------------------------------------------------------------------------------------------------------------------------------------------------------------------------------------------------------------------------------------------------------------------------------------------------------------------------------------|------------------------------------------------------------------------------------------------------------------------------------------------------------------------------------------------------------------------------------------------------------------------------------------------------------------------------------------------------------------------------------------------------------------------------------------------------------------------------------------------------------------------------------------------------------------------------------------------------|----------------------------------------------------------------------------------------------------------------------------------------------------------------------------------------------------------------------------------------------------------------------------------------------------------------------------------------------------------------------------------------------------------------------------------------------------------------------------------------------------------------------------------------------------------------------------------------------------------------------------------------------------------------------------------------------------------------------------------------------------------------|
| Restricted operations after upgrading to each stage | None           | <ul style="list-style-type: none"> <li>• No Cisco Prime NSC policy cfg change (assuming silent drops).</li> <li>• No VSM/VEM vservice VM operations (shutdown/bring up existing vservice VMs, bring down net adapters, etc).</li> <li>• No new vservice VMs is supported.</li> <li>• No Vmotion of vservice firewalled VMs on N1k</li> <li>• No vservice PP operations or modifications (toggles, removal, changing the PP on VSM).</li> <li>• VSG failover not supported, VSM failover (vns-agent) not supported (All VSM to Cisco Prime NSC to VSG control operations are restricted).</li> </ul> | <ul style="list-style-type: none"> <li>• No Cisco Prime NSC policy cfg change (assuming silent drops).</li> <li>• No VSM/VEM vservice VM operations (shutdown/bring up existing vservice VMs, bring down net adapters, etc).</li> <li>• No new vservice VMs is supported.</li> <li>• No Vmotion of vservice firewalled VMs on N1k.</li> <li>• No vservice PP operations or modifications (toggles, removal, changing the PP on VSM).</li> <li>• VSG failover not supported, VSM failover (vns-agent) not supported (All VSM to Cisco Prime NSC to VSG control operations are restricted).</li> </ul> | <p><b>The following restricted operations apply only if all VEMs are not upgraded:</b></p> <ul style="list-style-type: none"> <li>• No Cisco Prime NSC policy cfg change (assuming silent drops).</li> <li>• No VSM/VEM vservice VM operations (shutdown/bring up existing vservice VMs, bring down net adapters, etc).</li> <li>• No new vservice VMs is supported.</li> <li>• No boot strap of devices (VNMC, VSM, VSG).</li> <li>• No Vmotion of vservice VMs on N1k.</li> <li>• No vservice PP operations or modifications (toggles, removal, changing the PP on VSM).</li> <li>• No N1k switch (non vservice) operations, including non-vservice PPs (VSM+VEM upgraded) (All VSM to Cisco Prime NSC to VSG control operations are restricted).</li> </ul> |



**Note** ISSU upgrade is not supported for VSG and VSM that involves installing a new PA. However, on both , you should install the Cisco Prime NSC first. The new PA may not support the old VNMC.

## Upgrading VNMC Release 2.1 to Cisco Prime NSC 3.0.2

### Before You Begin

- You are logged in to the CLI in EXEC mode.
- You have backed up the new software files to a remote server and have verified that the backup file was created on the remote server.
- You must have the Cisco Prime NSC Release 3.0.2 downloaded.
- You have added two hard disks to the VNMC VM. For more information on Cisco Prime NSC requirements, see [System Requirements](#).

### SUMMARY STEPS

1. nsc# **connect local-mgmt**
2. (Optional) nsc (local-mgmt)# **show version**
3. (Optional) nsc (local-mgmt)# **copy scp://user@example-server-ip/example-dir/filename bootflash:/**
4. nsc (local-mgmt)# **dir bootflash:/**
5. nsc (local-mgmt)# **update bootflash:/filename**
6. (Optional) nsc (local-mgmt)# **service status**
7. (Optional) nsc (local-mgmt)# **show version**

### DETAILED STEPS

|               | Command or Action                                                                           | Purpose                                                                          |
|---------------|---------------------------------------------------------------------------------------------|----------------------------------------------------------------------------------|
| <b>Step 1</b> | nsc# <b>connect local-mgmt</b>                                                              | Places you in local management mode.                                             |
| <b>Step 2</b> | nsc (local-mgmt)# <b>show version</b>                                                       | (Optional)<br>Displays the version information for the Cisco Prime NSC software. |
| <b>Step 3</b> | nsc (local-mgmt)# <b>copy scp://user@example-server-ip/example-dir/filename bootflash:/</b> | (Optional)<br>Copies the Cisco Prime NSC software file to the VM.                |
| <b>Step 4</b> | nsc (local-mgmt)# <b>dir bootflash:/</b>                                                    | Verifies that the desired file is copied in the directory.                       |
| <b>Step 5</b> | nsc (local-mgmt)# <b>update bootflash:/filename</b>                                         | Begins the update of the Cisco Prime NSC software.                               |

|        | Command or Action                       | Purpose                                                                                                                                                                                                                                                                                                                                                                                                                   |
|--------|-----------------------------------------|---------------------------------------------------------------------------------------------------------------------------------------------------------------------------------------------------------------------------------------------------------------------------------------------------------------------------------------------------------------------------------------------------------------------------|
| Step 6 | nsc (local-mgmt)# <b>service status</b> | (Optional)<br>Allows you to verify that the server is operating as desired.                                                                                                                                                                                                                                                                                                                                               |
| Step 7 | nsc (local-mgmt)# <b>show version</b>   | (Optional)<br>Allows you to verify that the Cisco Prime NSC software version is updated.<br><br><b>Note</b> After you upgrade to Cisco Prime NSC Release 3.0.2, you might see the previous version of Cisco VNMC in your browser. To view the upgraded version, clear the browser cache and browsing history in the browser. This note applies to all supported browsers: Internet Explorer, Mozilla Firefox, and Chrome. |

### Configuration Example

The following example shows how to connect to the local-mgmt mode:

```
nsc# connect local-mgmt
Cisco Prime Network Services Controller
TAC support: http://www.cisco.com/tac
Copyright (c) 2002-2013, Cisco Systems, Inc. All rights reserved.
The copyrights to certain works contained in this software are
owned by other third parties and used and distributed under
license. Certain components of this software are licensed under
the GNU General Public License (GPL) version 2.0 or the GNU
Lesser General Public License (LGPL) Version 2.1. A copy of each
such license is available at
http://www.opensource.org/licenses/gpl-2.0.php and
http://www.opensource.org/licenses/lgpl-2.1.php
```

The following example shows how to display version information for the Cisco VNMC:

```
nsc (local-mgmt) # show version

Name                Package                Version                GUI
----                -
core                 Base System            2.1                    2.1
service-reg         Service Registry       2.1                    2.1
policy-mgr           Policy Manager         2.1                    2.1
resource-mgr         Resource Manager       2.1                    2.1
vm-mgr              VM manager             2.1                    none
```

The following example shows how to copy the Cisco Prime NSC software to the VM:

```
nsc (local-mgmt) # copy scp://<user@example-server-ip>/example1-dir/nsc.3.0.2e.bin bootflash:/
Enter password:
100% 143MB 11.9MB/s 00:12
```

The following example shows how to see the directory information for Cisco Prime NSC:

```
nsc (local-mgmt) # dir bootflash:/

      1.1G Oct 14 00:57 nsc.3.0.2e.bin

Usage for bootflash://

      6359716 KB used
     10889320 KB free
     18187836 KB total
```

The following example shows how to start the update for the Cisco Prime NSC:

```
nsc(local-mgmt)# update bootflash:/nsc.3.0.2e.bin
It is recommended that you perform a full-state backup before updating any VNMC component.
Press enter to continue or Ctrl-c to exit.
```

The following example shows how to display the updated version for the Cisco Prime NSC:

```
nsc(local-mgmt)# show version
```

| Name              | Package            | Version  | GUI      |
|-------------------|--------------------|----------|----------|
| core              | Base System        | 3.0 (2e) | 3.0 (2e) |
| service-reg       | Service Registry   | 3.0 (2e) | 3.0 (2e) |
| policy-mgr        | Policy Manager     | 3.0 (2e) | 3.0 (2e) |
| resource-mgr      | Resource Manager   | 3.0 (2e) | 3.0 (2e) |
| vm-mgr            | VM manager         | 3.0 (2e) | none     |
| cloudprovider-mgr | Cloud Provider Mgr | 3.0 (2e) | none     |

## Upgrading Cisco Prime NSC 3.0.2 to Cisco Prime NSC 3.2

### Before You Begin

- You are logged in to the CLI in EXEC mode.
- You have backed up the new software files to a remote server and have verified that the backup file was created on the remote server.
- You must have the Cisco Prime NSC Release 3.2 downloaded.
- You have added two hard disks to the Cisco Prime NSC VM. For more information on Cisco Prime NSC requirements, see [System Requirements](#).

### SUMMARY STEPS

1. nsc# **connect local-mgmt**
2. (Optional) nsc (local-mgmt)# **show version**
3. (Optional) nsc (local-mgmt)# **copy scp://user@example-server-ip/example-dir/filename bootflash:/**
4. nsc (local-mgmt)# **dir bootflash:/**
5. nsc (local-mgmt)# **update bootflash:/filename**
6. (Optional) nsc (local-mgmt)# **service status**
7. (Optional) nsc (local-mgmt)# **show version**

### DETAILED STEPS

|               | Command or Action                     | Purpose                                                                          |
|---------------|---------------------------------------|----------------------------------------------------------------------------------|
| <b>Step 1</b> | nsc# <b>connect local-mgmt</b>        | Places you in local management mode.                                             |
| <b>Step 2</b> | nsc (local-mgmt)# <b>show version</b> | (Optional)<br>Displays the version information for the Cisco Prime NSC software. |

|               | Command or Action                                                                           | Purpose                                                                                                                                                                                                                                                                                                                                                                                                                      |
|---------------|---------------------------------------------------------------------------------------------|------------------------------------------------------------------------------------------------------------------------------------------------------------------------------------------------------------------------------------------------------------------------------------------------------------------------------------------------------------------------------------------------------------------------------|
| <b>Step 3</b> | nsc (local-mgmt)# <b>copy scp://user@example-server-ip/example-dir/filename bootflash:/</b> | (Optional)<br>Copies the Cisco Prime NSC software file to the VM.                                                                                                                                                                                                                                                                                                                                                            |
| <b>Step 4</b> | nsc (local-mgmt)# <b>dir bootflash:/</b>                                                    | Verifies that the desired file is copied in the directory.                                                                                                                                                                                                                                                                                                                                                                   |
| <b>Step 5</b> | nsc (local-mgmt)# <b>update bootflash:/filename</b>                                         | Begins the update of the Cisco Prime NSC software.                                                                                                                                                                                                                                                                                                                                                                           |
| <b>Step 6</b> | nsc (local-mgmt)# <b>service status</b>                                                     | (Optional)<br>Allows you to verify that the server is operating as desired.                                                                                                                                                                                                                                                                                                                                                  |
| <b>Step 7</b> | nsc (local-mgmt)# <b>show version</b>                                                       | (Optional)<br>Allows you to verify that the Cisco Prime NSC software version is updated.<br><br><b>Note</b> After you upgrade to Cisco Prime NSC Release 3.2, you might see the previous version of Cisco Prime NSC in your browser. To view the upgraded version, clear the browser cache and browsing history in the browser. This note applies to all supported browsers: Internet Explorer, Mozilla Firefox, and Chrome. |

### Configuration Example

The following example shows how to connect to the local-mgmt mode:

```
nsc# connect local-mgmt
Cisco Prime Network Services Controller
TAC support: http://www.cisco.com/tac
Copyright (c) 2002-2013, Cisco Systems, Inc. All rights reserved.
The copyrights to certain works contained in this software are
owned by other third parties and used and distributed under
license. Certain components of this software are licensed under
the GNU General Public License (GPL) version 2.0 or the GNU
Lesser General Public License (LGPL) Version 2.1. A copy of each
such license is available at
http://www.opensource.org/licenses/gpl-2.0.php and
http://www.opensource.org/licenses/lgpl-2.1.php
```

The following example shows how to display version information for the Cisco Prime NSC:

```
nsc (local-mgmt) # show version

Name           Package           Version           GUI
-----
core           Base System       3.0 (2e)          3.0 (2e)
service-reg    Service Registry  3.0 (2e)          3.0 (2e)
policy-mgr     Policy Manager    3.0 (2e)          3.0 (2e)
resource-mgr   Resource Manager  3.0 (2e)          3.0 (2e)
vm-mgr         VM manager        3.0 (2e)          none
cloudprovider-mgr Cloud Provider Mgr 3.0 (2e)          none
```

The following example shows how to copy the Cisco Prime NSC software to the VM:

```
nsc (local-mgmt) # copy scp://<user@example-server-ip>/example1-dir/nsc.3.2.bin bootflash:/
Enter password:
100% 143MB 11.9MB/s 00:12
```

The following example shows how to see the directory information for Cisco Prime NSC:

```
nsc(local-mgmt)# dir bootflash:/
      1.1G Oct 14 00:57 nsc.3.2.bin
Usage for bootflash://
      6359716 KB used
      10889320 KB free
      18187836 KB total
```

The following example shows how to start the update for the Cisco Prime NSC:

```
nsc(local-mgmt)# update bootflash:/nsc.3.2.bin
It is recommended that you perform a full-state backup before updating any VNCM component.
Press enter to continue or Ctrl-c to exit.
```

The following example shows how to display the updated version for the Cisco Prime NSC:

```
nsc(local-mgmt)# show version
```

| Name              | Package            | Version | GUI  |
|-------------------|--------------------|---------|------|
| core              | Base System        | 3.2     | 3.2  |
| service-reg       | Service Registry   | 3.2     | 3.2  |
| policy-mgr        | Policy Manager     | 3.2     | 3.2  |
| resource-mgr      | Resource Manager   | 3.2     | 3.2  |
| vm-mgr            | VM manager         | 3.2     | none |
| cloudprovider-mgr | Cloud Provider Mgr | 3.2     | none |

## Upgrading Cisco VSG from Release 5.2(1)VSG1(4.1) to 5.2(1)VSG2(1.1a)

This section includes the following topics:

- [Cisco VSG Software Upgrade Guidelines](#), on page 86
- [Upgrade a VSG Pair in HA Mode](#), on page 87
- [Upgrading a Device for Standalone VSG](#), on page 90
- [Re-registering the Policy Agent with the Upgraded VSG](#), on page 93

### Before You Begin

- You are logged in to the CLI in EXEC mode.
- You have closed all the active VSG configuration sessions before upgrading the Cisco VSG software.
- You have copied the kickstart and system images from the remote server to the Cisco Nexus 1000V.

## Cisco VSG Software Upgrade Guidelines

Follow these VSG upgrade guidelines while upgrading the VSG:

- Schedule the upgrade when the network is stable. Ensure that nobody is configuring the switch during the upgrade.
- Ensure that sufficient space is available for copying the upgrade images. A minimum of 200 MB of free bootflash space is required on both the active and standby VSGs.
- Avoid power interruptions to the hosts running the VSG VMs during any installation procedure.
- Ensure that the management (mgmt0) interface of the VSG is working and accessible.



- Ensure that the specified system and kickstart images are compatible with each other.
- Verify connectivity to the remote server by using the ping command.

## Upgrade a VSG Pair in HA Mode

You can upgrade VSG pair in the High Availability (HA) mode.

### SUMMARY STEPS

1. Log in to the active VSG.
2. Display the current boot variables.
3. Verify that required space is available to copy the image files. Delete unnecessary files if required to create more space available for copying the new VSG image.
4. Verify that required space is available on the standby VSG. Delete unnecessary files if required to create more space available for copying the new VSG image.
5. Copy the Cisco Nexus 1000V kickstart and system software files to a server.
6. Remove current boot variables.
7. Display the current boot variables.
8. Load the new boot variables and copy the running configuration to the startup configuration.
9. Display the current boot variables.
10. Manually reboot the system.
11. After the installation operation completes, log in and verify that the switch is running the upgraded software version.

### DETAILED STEPS

**Step 1** Log in to the active VSG.

**Step 2** Display the current boot variables.

```
vsg# show boot
Current Boot Variables:

sup-1
kickstart variable = bootflash:/nexus-1000v-kickstart.5.2.1.VSG1.4.0.1.bin
system variable = bootflash:/nexus-1000v.5.2.1.VSG1.4.0.1.bin
sup-2
kickstart variable = bootflash:/nexus-1000v-kickstart.5.2.1.VSG1.4.0.1.bin
system variable = bootflash:/nexus-1000v.5.2.1.VSG1.4.0.1.bin
No module boot variable set

Boot Variables on next reload:

sup-1
kickstart variable = bootflash:/nexus-1000v-kickstart.5.2.1.VSG1.4.0.1.bin
system variable = bootflash:/nexus-1000v.5.2.1.VSG1.4.0.1.bin
sup-2
kickstart variable = bootflash:/nexus-1000v-kickstart.5.2.1.VSG1.4.0.1.bin
```

```
system variable = bootflash:/nexus-1000v.5.2.1.VSG1.4.0.1.bin
No module boot variable set
```

- Step 3** Verify that required space is available to copy the image files. Delete unnecessary files if required to create more space available for copying the new VSG image.

```
vsg(config)# dir
.
.
.
Usage for bootflash://
 692117504 bytes used
 5711851520 bytes free
 6403969024 bytes total
```

- Step 4** Verify that required space is available on the standby VSG. Delete unnecessary files if required to create more space available for copying the new VSG image.

```
vsg(config)# dir bootflash://sup-standby/
.
.
.
Usage for bootflash://sup-standby
 577372160 bytes used
 5826600960 bytes free
 6403973120 bytes total
```

- Step 5** Copy the Cisco Nexus 1000V kickstart and system software files to a server.

```
vsg(config)# copy scp://user@scpserver.cisco.com/downloads/nexus-1000v-kickstart.5.2.1.VSG2.1.1a.bin
./
vsg(config)#copy scp://user@scpserver.cisco.com/downloads/nexus-1000v.5.2.1.VSG2.1.1a.bin ./
```

- Step 6** Remove current boot variables.

```
vsg(config)# no boot system
vsg(config)# no boot kickstart
```

- Step 7** Display the current boot variables.

```
vsg(config)# show boot
Current Boot Variables:
sup-1
kickstart variable not set
system variable not set
sup-2
kickstart variable not set
system variable not set
No module boot variable set

Boot Variables on next reload:

sup-1
kickstart variable = bootflash:/nexus-1000v-kickstart.5.2.1.VSG1.4.0.1.bin
system variable = bootflash:/nexus-1000v.5.2.1.VSG1.4.0.1.bin
sup-2
kickstart variable = bootflash:/nexus-1000v-kickstart.5.2.1.VSG1.4.0.1.bin
system variable = bootflash:/nexus-1000v.5.2.1.VSG1.4.0.1.bin
No module boot variable set
```

- Step 8** Load the new boot variables and copy the running configuration to the startup configuration.

```
vsg# configure terminal
vsg(config)# boot system bootflash:///nexus-1000v.5.2.1.VSG2.1.1a.bin
```

```
vsg(config)# boot kickstart bootflash:///nexus-1000v-kickstart.5.2.1.VSG2.1.1a.bin
vsg(config)# copy running-config startup-config
```

**Step 9**

Display the current boot variables.

```
vsg(config)# show boot
Current Boot Variables:
```

```
sup-1
kickstart variable = bootflash:/nexus-1000v-kickstart.5.2.1.VSG2.1.1a.bin
system variable = bootflash:/nexus-1000v.5.2.1.VSG2.1.1a.bin
sup-2
kickstart variable = bootflash:/nexus-1000v-kickstart.5.2.1.VSG2.1.1a.bin
system variable = bootflash:/nexus-1000v.5.2.1.VSG2.1.1a.bin
No module boot variable set
```

Boot Variables on next reload:

```
sup-1
kickstart variable = bootflash:/nexus-1000v-kickstart.5.2.1.VSG2.1.1a.bin
system variable = bootflash:/nexus-1000v.5.2.1.VSG2.1.1a.bin
sup-2
kickstart variable = bootflash:/nexus-1000v-kickstart.5.2.1.VSG2.1.1a.bin
system variable = bootflash:/nexus-1000v.5.2.1.VSG2.1.1a.bin
No module boot variable set
```

**Step 10**

Manually reboot the system.

```
vsg(config)# reload
This command will reboot the system. (y/n)? [n]
```

If you want to continue with the reboot, press Y.

**Note** The system reboot takes approximately 10 seconds.

**Step 11**

After the installation operation completes, log in and verify that the switch is running the upgraded software version.

```
switch# show version
Cisco Nexus Operating System (NX-OS) Software
TAC support: http://www.cisco.com/tac
Documents: http://www.cisco.com/en/US/products/ps9372/tsd_products_support_series_home.html
Copyright (c) 2002-2013, Cisco Systems, Inc. All rights reserved.
The copyrights to certain works contained herein are owned by
other third parties and are used and distributed under license.
Some parts of this software are covered under the GNU Public
License. A copy of the license is available at
http://www.gnu.org/licenses/gpl.html.
```

```
Software
  loader:   version unavailable [last: image booted through mgmt0]
  kickstart: version 5.2(1)VSG2(1.1a)
  system:   version 5.2(1)VSG2(1.1a)
  system image file is:   bootflash:///nexus-1000v.5.2.1.VSG2.1.1a.bin
  system compile time:    12/6/2013 16:00:00 [12/06/2013 21:10:51]
```

```
Hardware
  cisco Nexus 1000V Chassis ("Virtual Supervisor Module")
  Intel(R) Xeon(R) CPU E5-2609 with 1933768 kB of memory.
```

```

Processor Board ID T155D4BC001

Device name: VSG_Fire
bootflash:    1451180 kB

Kernel uptime is 1 day(s), 16 hour(s), 30 minute(s), 38 second(s)

plugin
  Core Plugin, Ethernet Plugin, Virtualization Plugin
vsg #

```

---

## Upgrading a Device for Standalone VSG

### SUMMARY STEPS

1. Log in to the active VSG.
2. Use the show boot command to display the current boot variables.
3. Verify that required space is available to copy the image files. Delete unnecessary files if required to create more space available for copying the new VSG image.
4. Copy the Cisco Nexus 1000V kickstart and system software files to a server.
5. Remove current boot variables.
6. Display the current boot variables.
7. Load the new boot variables and copy the running configuration to the startup configuration.
8. Display the current boot variables.
9. Manually reboot the system.
10. After the installation operation completes, log in and verify that the switch is running the upgraded software version.

### DETAILED STEPS

**Step 1** Log in to the active VSG.

**Step 2** Use the show boot command to display the current boot variables.

```

vsg# show boot
Current Boot Variables:

sup-1
kickstart variable = bootflash:/nexus-1000v-kickstart.5.2.1.VSG1.4.0.1.bin
system variable = bootflash:/nexus-1000v.5.2.1.VSG1.4.0.1.bin
sup-2
kickstart variable = bootflash:/nexus-1000v-kickstart.5.2.1.VSG1.4.0.1.bin
system variable = bootflash:/nexus-1000v.5.2.1.VSG1.4.0.1.bin
No module boot variable set

Boot Variables on next reload:

```

```

sup-1
kickstart variable = bootflash:/nexus-1000v-kickstart.5.2.1.VSG1.4.0.1.bin
system variable = bootflash:/nexus-1000v.5.2.1.VSG1.4.0.1.bin
sup-2
kickstart variable = bootflash:/nexus-1000v-kickstart.5.2.1.VSG1.4.0.1.bin
system variable = bootflash:/nexus-1000v.5.2.1.VSG1.4.0.1.bin
No module boot variable set

```

**Step 3** Verify that required space is available to copy the image files. Delete unnecessary files if required to create more space available for copying the new VSG image.

```

vsg(config)# dir
.
.
.
Usage for bootflash://
 692117504 bytes used
5711851520 bytes free
6403969024 bytes total

```

**Step 4** Copy the Cisco Nexus 1000V kickstart and system software files to a server.

```

vsg(config)# copy scp://user@scpserver.cisco.com/downloads/nexus-1000v-kickstart.5.2.1.VSG2.1.1a.bin
./

```

**Step 5** Remove current boot variables.

```

vsg(config)# no boot system
vsg(config)# no boot kickstart

```

**Step 6** Display the current boot variables.

```

vsg(config)# show boot
Current Boot Variables:
sup-1
kickstart variable not set
system variable not set
sup-2
kickstart variable not set
system variable not set
No module boot variable set

```

Boot Variables on next reload:

```

sup-1
kickstart variable = bootflash:/nexus-1000v-kickstart.5.2.1.VSG1.4.0.1.bin
system variable = bootflash:/nexus-1000v.5.2.1.VSG1.4.0.1.bin
sup-2
kickstart variable = bootflash:/nexus-1000v-kickstart.5.2.1.VSG1.4.0.1.bin
system variable = bootflash:/nexus-1000v.5.2.1.VSG1.4.0.1.bin
No module boot variable set

```

**Step 7** Load the new boot variables and copy the running configuration to the startup configuration.

```

vsg# configure terminal
vsg(config)# boot system bootflash:///nexus-1000v.5.2.1.VSG2.1.1a.bin
vsg(config)# boot kickstart bootflash:///nexus-1000v-kickstart.5.2.1.VSG2.1.1a.bin
vsg(config)# copy running-config startup-config

```

**Step 8** Display the current boot variables.

```

vsg(config)# show boot
Current Boot Variables:

```

```

sup-1
kickstart variable = bootflash:/nexus-1000v-kickstart.5.2.1.VSG2.1.1a.bin
system variable = bootflash:/nexus-1000v.5.2.1.VSG2.1.1a.bin
sup-2
kickstart variable = bootflash:/nexus-1000v-kickstart.5.2.1.VSG2.1.1a.bin
system variable = bootflash:/nexus-1000v.5.2.1.VSG2.1.1a.bin
No module boot variable set

```

Boot Variables on next reload:

```

sup-1
kickstart variable = bootflash:/nexus-1000v-kickstart.5.2.1.VSG1.4.0.1.bin
system variable = bootflash:/nexus-1000v.5.2.1.VSG1.4.0.1.bin
sup-2
kickstart variable = bootflash:/nexus-1000v-kickstart.5.2.1.VSG1.4.0.1.bin
system variable = bootflash:/nexus-1000v.5.2.1.VSG1.4.0.1.bin
No module boot variable set

```

### Step 9 Manually reboot the system.

```
vsg(config)# reload
This command will reboot the system. (y/n)? [n]
```

If you want to continue with the reboot, press Y.

**Note** The system reboot takes approximately 10 seconds.

### Step 10 After the installation operation completes, log in and verify that the switch is running the upgraded software version.

```

switch# show version
Cisco Nexus Operating System (NX-OS) Software
TAC support: http://www.cisco.com/tac
Documents: http://www.cisco.com/en/US/products/ps9372/tsd_products_support_series_home.html
Copyright (c) 2002-2013, Cisco Systems, Inc. All rights reserved.
The copyrights to certain works contained herein are owned by
other third parties and are used and distributed under license.
Some parts of this software are covered under the GNU Public
License. A copy of the license is available at
http://www.gnu.org/licenses/gpl.html.

```

Software

```

loader:    version unavailable [last: image booted through mgmt0]
kickstart: version 5.2(1)VSG2(1.1a)
system:    version 5.2(1)VSG2(1.1a)
system image file is:  bootflash:///nexus-1000v.5.2.1.VSG2.1.1a.bin
system compile time:   12/6/2013 16:00:00 [12/06/2013 21:10:51]

```

Hardware

```

Cisco Nexus 1000V Chassis ("Virtual Supervisor Module")
Intel(R) Xeon(R) CPU E5-2609 with 1933768 kB of memory.
Processor Board ID T155D4BC001

```

```

Device name: VSG_Fire
bootflash:   1451180 kB

```

```
Kernel uptime is 1 day(s), 16 hour(s), 30 minute(s), 38 second(s)
```

```
plugin
  Core Plugin, Ethernet Plugin, Virtualization Plugin
vsg #
```

## Re-registering the Policy Agent with the Upgraded VSG

You need to re-register the policy agent after upgrading the Cisco VSG.

### SUMMARY STEPS

1. Log in to the active VSG.
2. Check the current policy agent version.
3. Enter the configuration mode.
4. Unregister the old policy agent from VSG.
5. Register the new policy agent with the VSG.
6. Copy the current running configuration to the startup configuration.
7. Verify the updated policy agent version.

### DETAILED STEPS

- 
- Step 1** Log in to the active VSG.
- Step 2** Check the current policy agent version.
- ```
vsg# show nsc-pa status
NSC Policy-Agent status is - Installed Successfully. Version 2.1(1a)-vsg
VSG#
```
- Step 3** Enter the configuration mode.
- ```
vsg# configure terminal
Enter configuration commands, one per line. End with CNTL/Z.
VSG(config)#
```
- Step 4** Unregister the old policy agent from VSG.
- ```
VSG(config)# nsc-policy-agent
VSG(config-nsc-policy-agent)# no policy-agent-image
```
- Step 5** Register the new policy agent with the VSG.
- ```
VSG(config-nsc-policy-agent)# policy-agent-image bootflash:vnmc-vsgpa.2.1.1e.bin
VSG(config-nsc-policy-agent)# exit
VSG(config)#
```
- Step 6** Copy the current running configuration to the startup configuration.
- ```
VSG(config)# copy running startup
[#####] 100%
```

**Step 7** Verify the updated policy agent version.

```
VSG(config)# show nsc-pa status
NSC Policy-Agent status is - Installed Successfully. Version 2.1(1e)-vsg
VSG(config)#
```

---

## Upgrading the Cisco Nexus 1000V for Microsoft Hyper-V

### Upgrading the Cisco Nexus 1000V for Microsoft Hyper-V

Upgrading the Cisco Nexus 1000V for Microsoft Hyper-V platform involves:

- Upgrading the VSM
- Upgrading the Cisco VSEM
- Upgrading the VEM Software

For detailed information about upgrading the Cisco Nexus 1000V for Microsoft Hyper-V, see the Upgrading the Cisco Nexus 1000V for Microsoft Hyper-V chapter in Cisco Nexus 1000V for Microsoft Hyper-V Installation and Upgrade Guide, available at: [http://www.cisco.com/en/US/partner/products/ps13056/prod\\_installation\\_guides\\_list.html](http://www.cisco.com/en/US/partner/products/ps13056/prod_installation_guides_list.html)





## INDEX

### A

- access [49](#)
  - firewall ports [49](#)

### B

- bootflash [69](#)

### C

- Cisco Cloud Service Platform [69](#)
  - installation [69](#)
- Cisco port profile [24](#)
- Cisco Prime NSC [47](#)
  - overview [47](#)
- CiscoPrime NSC [47](#)
  - system requirements [47](#)
- compute firewall [35](#)
- configuring [34, 60](#)
  - initial settings [60](#)
  - tenant on Prime NSC [34](#)
- configuring {security profile} [33](#)
  - compute firewall [33](#)
  - tenant [33](#)

### D

- dynamic operation [5](#)

### E

- enabling [38](#)
  - global policy engine logging [38](#)
- enabling logging [37](#)
- enabling traffic [38, 39](#)

### F

- firewall ports [49](#)
  - access [49](#)
- firewall protection [38, 39](#)

### G

- global policy-engine [38](#)
- guidelines and limitation [70](#)
  - cloud service platform [70](#)

### H

- hardware requirements [12](#)
- host requirements [19, 55](#)
- Hyper-V server [52](#)
  - requirement [52](#)

### I

- information [50](#)
  - configuration [50](#)
  - installation [50](#)
- initial settings [63](#)
- installing [52](#)
  - Cisco Prime NSC [52](#)
- Installing [27](#)
  - VSG from ISO image [27](#)
- installing Cisco VSG [57](#)
- installing Service provider foundation [41](#)
- ISO file [11, 57](#)

### L

- log [43](#)

logging [37](#)enabling [37](#)level 6 [37](#)policy engine [37](#)**M**multi-tenant [7](#)**N**Nexus 1000V device terminology [56](#)**P**password [51](#)shared secret [51](#)planning checklist [12](#)PNSC [7](#)policy agent [31, 61](#)port profile [26](#)prerequisites [16, 57](#)installing the VSG [57](#)Prime NSC [31, 61, 82, 84](#)Prime NSC architecture [8](#)Prime NSC benefits [7](#)Prime NSC components [8](#)Prime NSC installation [19](#)Prime NSC upgrade [78](#)**R**registering [65, 66](#)Cisco VSG [65](#)Nexus 1000V [66](#)requirements [14, 48](#)Prime NSC installation [14](#)VLAN configuration [14](#)web-based GUI client [48](#)rule [36](#)permit-all [36](#)**S**security policy [36](#)security profile [34](#)policy management [34](#)shared secret [51](#)password [51](#)software requirements [12](#)standby Cisco VSG [63](#)statistics [43](#)switch [49](#)requirements [49](#)system requirements [47](#)Cisco Prime NSC [47](#)**T**traffic flow [43, 44](#)**U**upgrade [77](#)procedure [77](#)upgrade guidelines [78](#)upgrading [82, 84](#)Upgrading Prime NSC [79](#)Upgrading VSG [78, 79](#)**V**verifying [36](#)permit-all rule [36](#)verifying communication [38](#)virtual network adapter [26](#)virtualization [5](#)VLAN setting [6](#)VLAN usages [6](#)VM communication [6](#)VM port-profile [39](#)VM requirements [55](#)vnmc [82](#)VNMC security [9](#)VSG [31, 61](#)VSG device terminology [56](#)VSG information [14](#)VSG setting [6](#)**W**web-based GUI client [48](#)requirements [48](#)