



CHAPTER 11

Configuring IEEE 802.1x Port-Based Authentication

This chapter describes how to configure IEEE 802.1x port-based authentication on the Catalyst 3750-X or 3560-X switch. IEEE 802.1x authentication prevents unauthorized devices (clients) from gaining access to the network. Unless otherwise noted, the term *switch* refers to a Catalyst 3750-X or 3560-X standalone switch and to a Catalyst 3750-X switch stack.



Note

For complete syntax and usage information for the commands used in this chapter, see the “RADIUS Commands” section in the *Cisco IOS Security Command Reference, Release 12.2* and the command reference or this release.

Switches running the IP base or IP services feature set also support Cisco TrustSec Security Group Tag (SGT) Exchange Protocol (SxP). This feature supports security group access control lists (SGACLs), which define ACL policies for a group of devices instead of an IP address. The SXP control protocol allows carrying the SGT information between access-layer devices at the Cisco TrustSec domain edge, and distribution layer devices within the Cisco TrustSec domain when the access-layer devices do not have the hardware capability to tag the packets. These switches operate as access layer switches in the Cisco TrustSec network.

For more information about Cisco TrustSec, see the “Cisco TrustSec Switch Configuration Guide” at this URL:

<http://www.cisco.com/en/US/docs/switches/lan/trustsec/configuration/guide/trustsec.html>

The sections on SXP define the capabilities supported on the switch.

This chapter consists of these sections:

- [Understanding IEEE 802.1x Port-Based Authentication, page 11-1](#)
- [Configuring 802.1x Authentication, page 11-34](#)
- [Displaying 802.1x Statistics and Status, page 11-70](#)

Understanding IEEE 802.1x Port-Based Authentication

The IEEE 802.1x standard defines a client-server-based access control and authentication protocol that prevents unauthorized clients from connecting to a LAN through publicly accessible ports unless they are properly authenticated. The authentication server authenticates each client connected to a switch port before making available any services offered by the switch or the LAN.

Until the client is authenticated, IEEE 802.1x access control allows only Extensible Authentication Protocol over LAN (EAPOL), Cisco Discovery Protocol (CDP), and Spanning Tree Protocol (STP) traffic through the port to which the client is connected. After authentication is successful, normal traffic can pass through the port.

These sections describe IEEE 802.1x port-based authentication:

- [Device Roles](#), page 11-3
- [Authentication Process](#), page 11-4
- [Authentication Initiation and Message Exchange](#), page 11-6
- [Authentication Manager](#), page 11-8
- [Ports in Authorized and Unauthorized States](#), page 11-10
- [802.1x Authentication and Switch Stacks](#), page 11-11
- [802.1x Host Mode](#), page 11-12
- [MAC Move](#), page 11-13
- [802.1x Accounting](#), page 11-13
- [802.1x Accounting Attribute-Value Pairs](#), page 11-13
- [802.1x Multiple Authentication Mode](#), page 11-12
- [802.1x Readiness Check](#), page 11-14
- [802.1x Authentication with Per-User ACLs](#), page 11-16
- [802.1x Authentication with Guest VLAN](#), page 11-19
- [802.1x Authentication with Restricted VLAN](#), page 11-20
- [802.1x Authentication with Inaccessible Authentication Bypass](#), page 11-21
- [802.1x Authentication with Downloadable ACLs and Redirect URLs](#), page 11-17
- [VLAN ID-based MAC Authentication](#), page 11-18
- [IEEE 802.1x Authentication with Voice VLAN Ports](#), page 11-23
- [IEEE 802.1x Authentication with Port Security](#), page 11-24
- [IEEE 802.1x Authentication with Wake-on-LAN](#), page 11-25
- [IEEE 802.1x Authentication with MAC Authentication Bypass](#), page 11-25
- [802.1x User Distribution](#), page 11-22
- [Network Admission Control Layer 2 IEEE 802.1x Validation](#), page 11-27
- [Multidomain Authentication](#), page 11-28
- [Flexible Authentication Ordering](#), page 11-27
- [Open1x Authentication](#), page 11-27
- [802.1x Supplicant and Authenticator Switches with Network Edge Access Topology \(NEAT\)](#), page 11-29
- [Voice Aware 802.1x Security](#), page 11-30
- [Common Session ID](#), page 11-31
- [Understanding Media Access Control Security and MACsec Key Agreement](#), page 11-31

Device Roles

With 802.1x port-based authentication, the devices in the network have specific roles as shown in Figure 11-1.

Figure 11-1 802.1x Device Roles

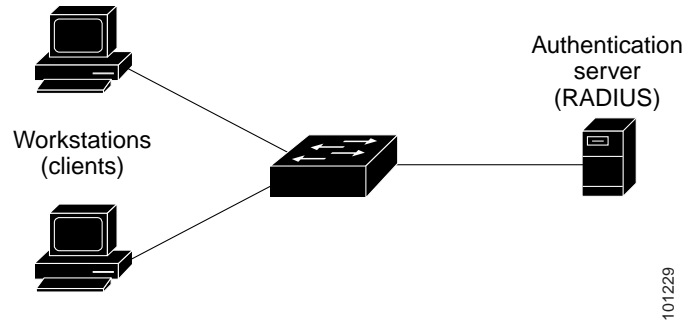

- *Client*—the device (workstation) that requests access to the LAN and switch services and responds to requests from the switch. The workstation must be running 802.1x-compliant client software such as that offered in the Microsoft Windows XP operating system. (The client is the *supplicant* in the 802.1x standard.)



Note To resolve Windows XP network connectivity and 802.1x authentication issues, read the Microsoft Knowledge Base article at this URL:

<http://support.microsoft.com/support/kb/articles/Q303/5/97.ASP>

- *Authentication server*—performs the actual authentication of the client. The authentication server validates the identity of the client and notifies the switch whether or not the client is authorized to access the LAN and switch services. Because the switch acts as the proxy, the authentication service is transparent to the client. In this release, the RADIUS security system with Extensible Authentication Protocol (EAP) extensions is the only supported authentication server. It is available in Cisco Secure Access Control Server Version 3.0 or later. RADIUS operates in a client/server model in which secure authentication information is exchanged between the RADIUS server and one or more RADIUS clients.
- *Switch* (edge switch or wireless access point)—controls the physical access to the network based on the authentication status of the client. The switch acts as an intermediary (proxy) between the client and the authentication server, requesting identity information from the client, verifying that information with the authentication server, and relaying a response to the client. The switch includes the RADIUS client, which is responsible for encapsulating and decapsulating the EAP frames and interacting with the authentication server. (The switch is the *authenticator* in the 802.1x standard.)

When the switch receives EAPOL frames and relays them to the authentication server, the Ethernet header is stripped, and the remaining EAP frame is re-encapsulated in the RADIUS format. The EAP frames are not modified during encapsulation, and the authentication server must support EAP within the native frame format. When the switch receives frames from the authentication server, the server's frame header is removed, leaving the EAP frame, which is then encapsulated for Ethernet and sent to the client.

The devices that can act as intermediaries include the Catalyst 3750-X, Catalyst 3750-E, Catalyst 3750, Catalyst 3650-X, Catalyst 3560-E, Catalyst 3560, Catalyst 3550, Catalyst 2970, Catalyst 2960, Catalyst 2955, Catalyst 2950, Catalyst 2940 switches, or a wireless access point. These devices must be running software that supports the RADIUS client and IEEE 802.1x authentication.

Authentication Process

When 802.1x port-based authentication is enabled and the client supports 802.1x-compliant client software, these events occur:

- If the client identity is valid and the 802.1x authentication succeeds, the switch grants the client access to the network.
- If 802.1x authentication times out while waiting for an EAPOL message exchange and MAC authentication bypass is enabled, the switch can use the client MAC address for authorization. If the client MAC address is valid and the authorization succeeds, the switch grants the client access to the network. If the client MAC address is invalid and the authorization fails, the switch assigns the client to a guest VLAN that provides limited services if a guest VLAN is configured.
- If the switch gets an invalid identity from an 802.1x-capable client and a restricted VLAN is specified, the switch can assign the client to a restricted VLAN that provides limited services.
- If the RADIUS authentication server is unavailable (down) and inaccessible authentication bypass is enabled, the switch grants the client access to the network by putting the port in the critical-authentication state in the RADIUS-configured or the user-specified access VLAN.



Note Inaccessible authentication bypass is also referred to as critical authentication or the AAA fail policy.

Figure 11-2 shows the authentication process.

If Multi Domain Authentication (MDA) is enabled on a port, this flow can be used with some exceptions that are applicable to voice authorization. For more information on MDA, see [“Multidomain Authentication” section on page 11-28](#).

Figure 11-2 Authentication Flowchart

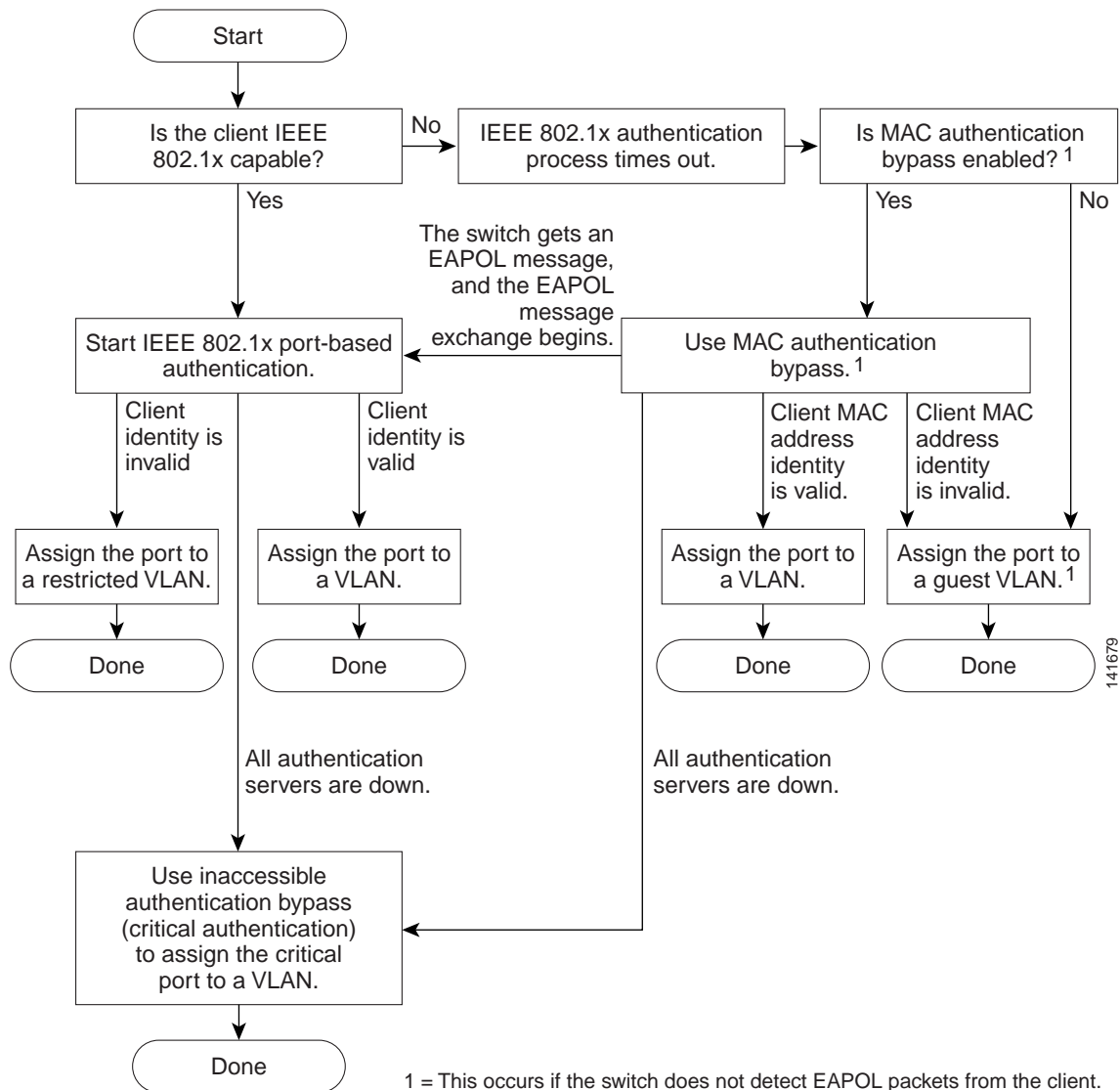

The switch re-authenticates a client when one of these situations occurs:

- Periodic re-authentication is enabled, and the re-authentication timer expires.

You can configure the re-authentication timer to use a switch-specific value or to be based on values from the RADIUS server.

After 802.1x authentication using a RADIUS server is configured, the switch uses timers based on the Session-Timeout RADIUS attribute (Attribute[27]) and the Termination-Action RADIUS attribute (Attribute [29]).

The Session-Timeout RADIUS attribute (Attribute[27]) specifies the time after which re-authentication occurs.

The Termination-Action RADIUS attribute (Attribute [29]) specifies the action to take during re-authentication. The actions are *Initialize* and *ReAuthenticate*. When the *Initialize* action is set (the attribute value is *DEFAULT*), the 802.1x session ends, and connectivity is lost during re-authentication. When the *ReAuthenticate* action is set (the attribute value is RADIUS-Request), the session is not affected during re-authentication.

- You manually re-authenticate the client by entering the **dot1x re-authenticate interface interface-id** privileged EXEC command.

Authentication Initiation and Message Exchange

During 802.1x authentication, the switch or the client can initiate authentication. If you enable authentication on a port by using the **authentication port-control auto** or **dot1x port-control auto** interface configuration command, the switch initiates authentication when the link state changes from down to up or periodically as long as the port remains up and unauthenticated. The switch sends an EAP-request/identity frame to the client to request its identity. Upon receipt of the frame, the client responds with an EAP-response/identity frame.

However, if during bootup, the client does not receive an EAP-request/identity frame from the switch, the client can initiate authentication by sending an EAPOL-start frame, which prompts the switch to request the client's identity.



Note

If 802.1x authentication is not enabled or supported on the network access device, any EAPOL frames from the client are dropped. If the client does not receive an EAP-request/identity frame after three attempts to start authentication, the client sends frames as if the port is in the authorized state. A port in the authorized state effectively means that the client has been successfully authenticated. For more information, see the [“Ports in Authorized and Unauthorized States”](#) section on page 11-10.

When the client supplies its identity, the switch begins its role as the intermediary, passing EAP frames between the client and the authentication server until authentication succeeds or fails. If the authentication succeeds, the switch port becomes authorized. If the authentication fails, authentication can be retried, the port might be assigned to a VLAN that provides limited services, or network access is not granted. For more information, see the [“Ports in Authorized and Unauthorized States”](#) section on page 11-10.

The specific exchange of EAP frames depends on the authentication method being used. [Figure 11-3](#) shows a message exchange initiated by the client when the client uses the One-Time-Password (OTP) authentication method with a RADIUS server.

Figure 11-3 Message Exchange

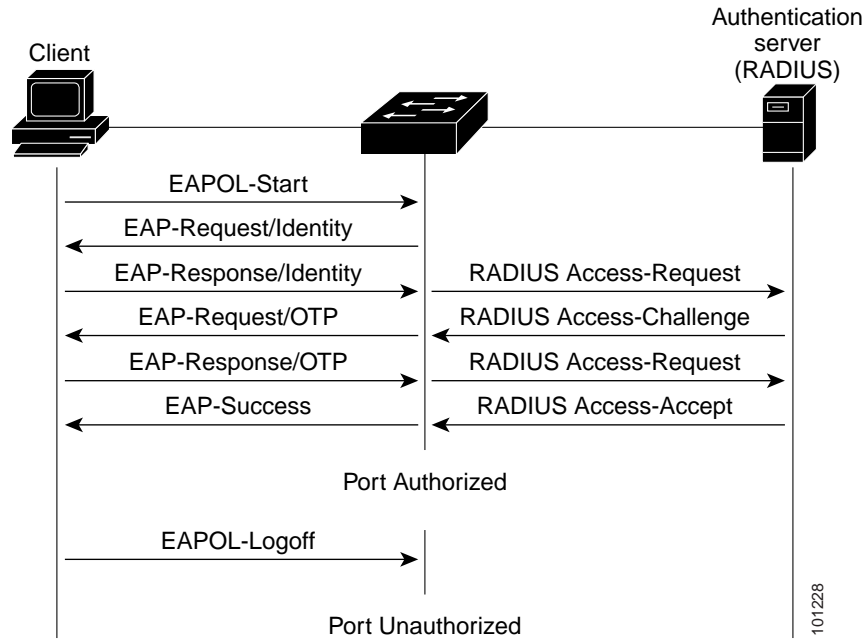

If 802.1x authentication times out while waiting for an EAPOL message exchange and MAC authentication bypass is enabled, the switch can authorize the client when the switch detects an Ethernet packet from the client. The switch uses the MAC address of the client as its identity and includes this information in the RADIUS-access/request frame that is sent to the RADIUS server. After the server sends the switch the RADIUS-access/accept frame (authorization is successful), the port becomes authorized. If authorization fails and a guest VLAN is specified, the switch assigns the port to the guest VLAN. If the switch detects an EAPOL packet while waiting for an Ethernet packet, the switch stops the MAC authentication bypass process and stops 802.1x authentication.

Figure 11-4 shows the message exchange during MAC authentication bypass.

Figure 11-4 Message Exchange During MAC Authentication Bypass

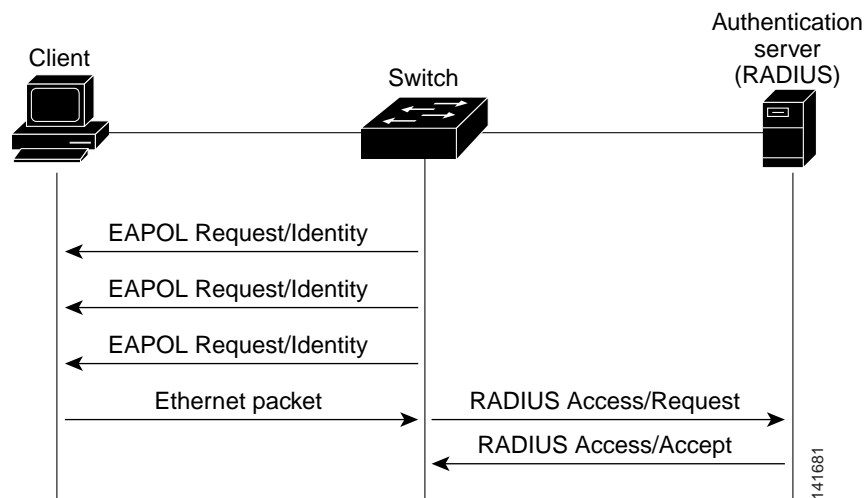

Authentication Manager

In Cisco IOS Release 12.2(46)SE and earlier, you could not use the same authorization methods, including CLI commands and messages, on this switch and also on other network devices, such as a Catalyst 6000. You had to use separate authentication configurations. Cisco IOS Release 12.2(50)SE and later supports the same authorization methods on all Catalyst switches in a network.

- [Port-Based Authentication Methods, page 11-8](#)
- [Per-User ACLs and Filter-Ids, page 11-9](#)
- [Authentication Manager CLI Commands, page 11-9](#)

Port-Based Authentication Methods

Table 11-1 802.1x Features

Authentication method	Mode			
	Single host	Multiple host	MDA ¹	Multiple Authentication ²²
802.1x	VLAN assignment Per-user ACL Filter-ID attribute Downloadable ACL ³ Redirect URL ²	VLAN assignment	VLAN assignment Per-user ACL ² Filter-Id attribute ² Downloadable ACL ² Redirect URL ²	Per-user ACL ² Filter-Id attribute ² Downloadable ACL ² Redirect URL ²
MAC authentication bypass	VLAN assignment Per-user ACL Filter-ID attribute Downloadable ACL ² Redirect URL ²	VLAN assignment	VLAN assignment Per-user ACL ² Filter-Id attribute ² Downloadable ACL ² Redirect URL ²	Per-user ACL ² Filter-Id attribute ² Downloadable ACL ² Redirect URL ²
Standalone web authentication ⁴	Proxy ACL, Filter-Id attribute, downloadable ACL ²			
NAC Layer 2 IP validation	Filter-Id attribute ² Downloadable ACL Redirect URL	Filter-Id attribute ² Downloadable ACL Redirect URL	Filter-Id attribute ² Downloadable ACL Redirect URL	Filter-Id attribute ² Downloadable ACL ² Redirect URL ²
Web authentication as fallback method ⁴	Proxy ACL Filter-Id attribute ² Downloadable ACL ²	Proxy ACL Filter-Id attribute ² Downloadable ACL ²	Proxy ACL Filter-Id attribute ² Downloadable ACL ²	Proxy ACL ² Filter-Id attribute ² Downloadable ACL ²

1. MDA = Multidomain authentication.
2. Also referred to as *multiauth*.
3. Supported in Cisco IOS Release 12.2(50)SE and later.
4. For clients that do not support 802.1x authentication.

Per-User ACLs and Filter-Ids

ACLs configured on the switch are compatible with other devices running Cisco IOS releases. You can only set **any** as the source in the ACL.



Note For any ACL configured for multiple-host mode, the source portion of statement must be *any*. (For example, **permit icmp any host 10.10.1.1**.)

Authentication Manager CLI Commands

The authentication-manager interface-configuration commands control all the authentication methods, such as 802.1x, MAC authentication bypass, and web authentication. The authentication manager commands determine the priority and order of authentication methods applied to a connected host.

The authentication manager commands control generic authentication features, such as host-mode, violation mode, and the authentication timer. Generic authentication commands include the **authentication host-mode**, **authentication violation**, and **authentication timer** interface configuration commands.

802.1x-specific commands begin with the **dot1x** keyword. For example, the **authentication port-control auto** interface configuration command enables authentication on an interface. However, the **dot1x system-authentication control** global configuration command only globally enables or disables 802.1x authentication.



Note If 802.1x authentication is globally disabled, other authentication methods are still enabled on that port, such as web authentication.

The **authentication manager** commands provide the same functionality as earlier 802.1x commands.

Table 11-2 Authentication Manager Commands and Earlier 802.1x Commands

The authentication manager commands in Cisco IOS Release 12.2(50)SE or later	The equivalent 802.1x commands in Cisco IOS Release 12.2(46)SE and earlier	Description
authentication control-direction { both in }	dot1x control-direction { both in }	Enable 802.1x authentication with the wake-on-LAN (WoL) feature, and configure the port control as unidirectional or bidirectional.
authentication event	dot1x auth-fail vlan dot1x critical (interface configuration) dot1x guest-vlan6	Enable the restricted VLAN on a port. Enable the inaccessible-authentication-bypass feature. Specify an active VLAN as an 802.1x guest VLAN.
authentication fallback <i>fallback-profile</i>	dot1x fallback <i>fallback-profile</i>	Configure a port to use web authentication as a fallback method for clients that do not support 802.1x authentication.
authentication host-mode [multi-auth multi-domain multi-host single-host]	dot1x host-mode { single-host multi-host multi-domain }	Allow a single host (client) or multiple hosts on an 802.1x-authorized port.

Table 11-2 Authentication Manager Commands and Earlier 802.1x Commands (continued)

The authentication manager commands in Cisco IOS Release 12.2(50)SE or later	The equivalent 802.1x commands in Cisco IOS Release 12.2(46)SE and earlier	Description
authentication order	dot1x mac-auth-bypass	Enable the MAC authentication bypass feature.
authentication periodic	dot1x reauthentication	Enable periodic re-authentication of the client.
authentication port-control { auto force-authorized force-unauthorized }	dot1x port-control { auto force-authorized force-unauthorized }	Enable manual control of the authorization state of the port.
authentication timer	dot1x timeout	Set the 802.1x timers.
authentication violation { protect restrict shutdown }	dot1x violation-mode { shutdown restrict protect }	Configure the violation modes that occur when a new device connects to a port or when a new device connects to a port after the maximum number of devices are connected to that port.
show authentication	show dot1x	Display 802.1x statistics, administrative status, and operational status for the switch or for the specified port. authentication manager: compatibility with earlier 802.1x CLI commands

For more information, see the command reference for this release.

Ports in Authorized and Unauthorized States

During 802.1x authentication, depending on the switch port state, the switch can grant a client access to the network. The port starts in the *unauthorized* state. While in this state, the port that is not configured as a voice VLAN port disallows all ingress and egress traffic except for 802.1x authentication, CDP, and STP packets. When a client is successfully authenticated, the port changes to the *authorized* state, allowing all traffic for the client to flow normally. If the port is configured as a voice VLAN port, the port allows VoIP traffic and 802.1x protocol packets before the client is successfully authenticated.

If a client that does not support 802.1x authentication connects to an unauthorized 802.1x port, the switch requests the client's identity. In this situation, the client does not respond to the request, the port remains in the unauthorized state, and the client is not granted access to the network.

In contrast, when an 802.1x-enabled client connects to a port that is not running the 802.1x standard, the client initiates the authentication process by sending the EAPOL-start frame. When no response is received, the client sends the request for a fixed number of times. Because no response is received, the client begins sending frames as if the port is in the authorized state.

You control the port authorization state by using the **dot1x port-control** interface configuration command and these keywords:

- **force-authorized**—disables 802.1x authentication and causes the port to change to the authorized state without any authentication exchange required. The port sends and receives normal traffic without 802.1x-based authentication of the client. This is the default setting.
- **force-unauthorized**—causes the port to remain in the unauthorized state, ignoring all attempts by the client to authenticate. The switch cannot provide authentication services to the client through the port.

- **auto**—enables 802.1x authentication and causes the port to begin in the unauthorized state, allowing only EAPOL frames to be sent and received through the port. The authentication process begins when the link state of the port changes from down to up or when an EAPOL-start frame is received. The switch requests the identity of the client and begins relaying authentication messages between the client and the authentication server. Each client attempting to access the network is uniquely identified by the switch by using the client MAC address.

If the client is successfully authenticated (receives an Accept frame from the authentication server), the port state changes to authorized, and all frames from the authenticated client are allowed through the port. If the authentication fails, the port remains in the unauthorized state, but authentication can be retried. If the authentication server cannot be reached, the switch can resend the request. If no response is received from the server after the specified number of attempts, authentication fails, and network access is not granted.

When a client logs off, it sends an EAPOL-logoff message, causing the switch port to change to the unauthorized state.

If the link state of a port changes from up to down, or if an EAPOL-logoff frame is received, the port returns to the unauthorized state.

802.1x Authentication and Switch Stacks

If a switch is added to or removed from a switch stack, 802.1x authentication is not affected as long as the IP connectivity between the RADIUS server and the stack remains intact. This statement also applies if the stack master is removed from the switch stack. Note that if the stack master fails, a stack member becomes the new stack master by using the election process described in [Chapter 5, “Managing Switch Stacks,”](#) and the 802.1x authentication process continues as usual.

If IP connectivity to the RADIUS server is interrupted because the switch that was connected to the server is removed or fails, these events occur:

- Ports that are already authenticated and that do not have periodic re-authentication enabled remain in the authenticated state. Communication with the RADIUS server is not required.
- Ports that are already authenticated and that have periodic re-authentication enabled (with the **dot1x re-authentication** global configuration command) fail the authentication process when the re-authentication occurs. Ports return to the unauthenticated state during the re-authentication process. Communication with the RADIUS server is required.

For an ongoing authentication, the authentication fails immediately because there is no server connectivity.

If the switch that failed comes up and rejoins the switch stack, the authentications might or might not fail depending on the boot-up time and whether the connectivity to the RADIUS server is re-established by the time the authentication is attempted.

To avoid loss of connectivity to the RADIUS server, you should ensure that there is a redundant connection to it. For example, you can have a redundant connection to the stack master and another to a stack member, and if the stack master fails, the switch stack still has connectivity to the RADIUS server.

802.1x Host Mode

You can configure an 802.1x port for single-host or for multiple-hosts mode. In single-host mode (see [Figure 12-1 on page 12-2](#)), only one client can be connected to the 802.1x-enabled switch port. The switch detects the client by sending an EAPOL frame when the port link state changes to the up state. If a client leaves or is replaced with another client, the switch changes the port link state to down, and the port returns to the unauthorized state.

In multiple-hosts mode, you can attach multiple hosts to a single 802.1x-enabled port. [Figure 11-5 on page 11-12](#) shows 802.1x port-based authentication in a wireless LAN. In this mode, only one of the attached clients must be authorized for all clients to be granted network access. If the port becomes unauthorized (re-authentication fails or an EAPOL-logoff message is received), the switch denies network access to all of the attached clients. In this topology, the wireless access point is responsible for authenticating the clients attached to it, and it also acts as a client to the switch.

With the multiple-hosts mode enabled, you can use 802.1x authentication to authenticate the port and port security to manage network access for all MAC addresses, including that of the client.

Figure 11-5 Multiple Host Mode Example

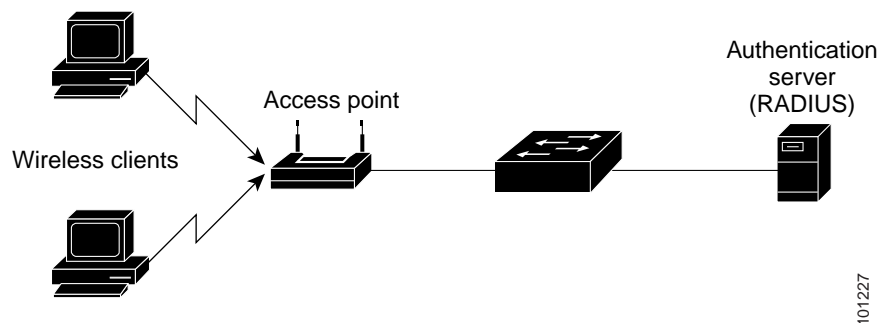

802.1x Multiple Authentication Mode

Multiple-authentication (multiauth) mode allows one client on the voice VLAN and multiple authenticated clients on the data VLAN. When a hub or access point is connected to an 802.1x-enabled port, multiple-authentication mode provides enhanced security over multiple-hosts mode by requiring authentication of each connected client. For non-802.1x devices, you can use MAC authentication bypass or web authentication as the fallback method for individual host authentications to authenticate different hosts through by different methods on a single port.

Multiple-authentication mode also supports MDA functionality on the voice VLAN by assigning authenticated devices to either a data or voice VLAN, depending on the VSAs received from the authentication server.



Note

When a port is in multiple-authentication mode, the RADIUS-server-supplied VLAN assignment, guest VLAN, and the authentication-failed VLAN features do not activate.

For more information about critical authentication mode and the critical VLAN, see the [“802.1x Authentication with Inaccessible Authentication Bypass”](#) section on page 11-21.

For more information see the [“Configuring the Host Mode”](#) section on page 11-45.

MAC Move

When a MAC address is authenticated on one switch port, that address is not allowed on another 802.1x port of the switch. If the switch detects that same MAC address on another 802.1x port, the address is not allowed.

There are situations where a MAC address might need to move from one port to another on the same switch. For example, when there is another device (for example a hub or an IP phone) between an authenticated host and a switch port, you might want to disconnect the host from the device and connect it directly to another port on the same switch.

You can globally enable MAC move so the device is reauthenticated on the new port. When a host moves to a second port, the session on the first port is deleted, and the host is reauthenticated on the new port.

MAC move is supported on all host modes. (The authenticated host can move to any port on the switch, no matter which host mode is enabled on the that port.)



Note

MAC move is not supported on port-security enabled 802.1x ports. If MAC move is globally configured on the switch and a port security-enabled host moves to an 802.1x-enabled port, a violation error occurs.

For more information see the [“Enabling MAC Move” section on page 11-50](#).

802.1x Accounting

The 802.1x standard defines how users are authorized and authenticated for network access but does not keep track of network usage. 802.1x accounting is disabled by default. You can enable 802.1x accounting to monitor this activity on 802.1x-enabled ports:

- User successfully authenticates.
- User logs off.
- Link-down occurs.
- Re-authentication successfully occurs.
- Re-authentication fails.

The switch does not log 802.1x accounting information. Instead, it sends this information to the RADIUS server, which must be configured to log accounting messages.

802.1x Accounting Attribute-Value Pairs

The information sent to the RADIUS server is represented in the form of Attribute-Value (AV) pairs. These AV pairs provide data for different applications. (For example, a billing application might require information that is in the Acct-Input-Octets or the Acct-Output-Octets attributes of a RADIUS packet.)

AV pairs are automatically sent by a switch that is configured for 802.1x accounting. Three types of RADIUS accounting packets are sent by a switch:

- START—sent when a new user session starts
- INTERIM—sent during an existing session for updates
- STOP—sent when a session terminates

Table 11-3 lists the AV pairs and when they are sent are sent by the switch:

Table 11-3 Accounting AV Pairs

Attribute Number	AV Pair Name	START	INTERIM	STOP
Attribute[1]	User-Name	Always	Always	Always
Attribute[4]	NAS-IP-Address	Always	Always	Always
Attribute[5]	NAS-Port	Always	Always	Always
Attribute[8]	Framed-IP-Address	Never	Sometimes ¹	Sometimes ¹
Attribute[25]	Class	Always	Always	Always
Attribute[30]	Called-Station-ID	Always	Always	Always
Attribute[31]	Calling-Station-ID	Always	Always	Always
Attribute[40]	Acct-Status-Type	Always	Always	Always
Attribute[41]	Acct-Delay-Time	Always	Always	Always
Attribute[42]	Acct-Input-Octets	Never	Always	Always
Attribute[43]	Acct-Output-Octets	Never	Always	Always
Attribute[44]	Acct-Session-ID	Always	Always	Always
Attribute[45]	Acct-Authentic	Always	Always	Always
Attribute[46]	Acct-Session-Time	Never	Always	Always
Attribute[49]	Acct-Terminate-Cause	Never	Never	Always
Attribute[61]	NAS-Port-Type	Always	Always	Always

1. The Framed-IP-Address AV pair is sent only if a valid Dynamic Host Control Protocol (DHCP) binding exists for the host in the DHCP snooping bindings table.

You can view the AV pairs that are being sent by the switch by entering the **debug radius accounting** privileged EXEC command. For more information about this command, see the *Cisco IOS Debug Command Reference, Release 12.2* at this URL:

http://www.cisco.com/en/US/products/sw/iosswrel/ps1835/products_command_reference_book09186a00800872ce.html

For more information about AV pairs, see RFC 3580, “IEEE 802.1x Remote Authentication Dial In User Service (RADIUS) Usage Guidelines.”

802.1x Readiness Check

The 802.1x readiness check monitors 802.1x activity on all the switch ports and displays information about the devices connected to the ports that support 802.1x. You can use this feature to determine if the devices connected to the switch ports are 802.1x-capable. You use an alternate authentication such as MAC authentication bypass or web authentication for the devices that do not support 802.1x functionality.

This feature only works if the supplicant on the client supports a query with the NOTIFY EAP notification packet. The client must respond within the 802.1x timeout value.

For information on configuring the switch for the 802.1x readiness check, see the [“Configuring 802.1x Readiness Check” section on page 11-39](#).

802.1x Authentication with VLAN Assignment

The switch supports 802.1x authentication with VLAN assignment. After successful 802.1x authentication of a port, the RADIUS server sends the VLAN assignment to configure the switch port. The RADIUS server database maintains the username-to-VLAN mappings, assigning the VLAN based on the username of the client connected to the switch port. You can use this feature to limit network access for certain users.

Voice device authentication is supported with multidomain host mode. When a voice device is authorized and the RADIUS server returned an authorized VLAN, the voice VLAN on the port is configured to send and receive packets on the assigned voice VLAN. Voice VLAN assignment behaves the same as data VLAN assignment on multidomain authentication (MDA)-enabled ports. For more information, see the [“Multidomain Authentication” section on page 11-28](#).

When configured on the switch and the RADIUS server, 802.1x authentication with VLAN assignment has these characteristics:

- If no VLAN is supplied by the RADIUS server or if 802.1x authentication is disabled, the port is configured in its access VLAN after successful authentication. Recall that an access VLAN is a VLAN assigned to an access port. All packets sent from or received on this port belong to this VLAN.
- If 802.1x authentication is enabled but the VLAN information from the RADIUS server is not valid, authorization fails and configured VLAN remains in use. This prevents ports from appearing unexpectedly in an inappropriate VLAN because of a configuration error.

Configuration errors could include specifying a VLAN for a routed port, a malformed VLAN ID, a nonexistent or internal (routed port) VLAN ID, an RSPAN VLAN, a shut down or suspended VLAN. In the case of a multidomain host port, configuration errors can also be due to an attempted assignment of a data VLAN that matches the configured or assigned voice VLAN ID (or the reverse).

- If 802.1x authentication is enabled and all information from the RADIUS server is valid, the authorized device is placed in the specified VLAN after authentication.
- If the multiple-hosts mode is enabled on an 802.1x port, all hosts are placed in the same VLAN (specified by the RADIUS server) as the first authenticated host.
- Enabling port security does not impact the RADIUS server-assigned VLAN behavior.
- If 802.1x authentication is disabled on the port, it is returned to the configured access VLAN and configured voice VLAN.

When the port is in the force authorized, force unauthorized, unauthorized, or shutdown state, it is put into the configured access VLAN.

If an 802.1x port is authenticated and put in the RADIUS server-assigned VLAN, any change to the port access VLAN configuration does not take effect. In the case of a multidomain host, the same applies to voice devices when the port is fully authorized with these exceptions:

- If the VLAN configuration change of one device results in matching the other device configured or assigned VLAN, authorization of all devices on the port is terminated and multidomain host mode is disabled until a valid configuration is restored where data and voice device configured VLANs no longer match.

- If a voice device is authorized and is using a downloaded voice VLAN, the removal of the voice VLAN configuration, or modifying the configuration value to *dot1p* or *untagged* results in voice device un-authorization and the disablement of multi-domain host mode.

The 802.1x authentication with VLAN assignment feature is not supported on trunk ports, dynamic ports, or with dynamic-access port assignment through a VLAN Membership Policy Server (VMPS).

To configure VLAN assignment you need to perform these tasks:

- Enable AAA authorization by using the **network** keyword to allow interface configuration from the RADIUS server.
- Enable 802.1x authentication. (The VLAN assignment feature is automatically enabled when you configure 802.1x authentication on an access port).
- Assign vendor-specific tunnel attributes in the RADIUS server. The RADIUS server must return these attributes to the switch:
 - [64] Tunnel-Type = VLAN
 - [65] Tunnel-Medium-Type = 802
 - [81] Tunnel-Private-Group-ID = VLAN name or VLAN ID

Attribute [64] must contain the value *VLAN* (type 13). Attribute [65] must contain the value *802* (type 6). Attribute [81] specifies the *VLAN name* or *VLAN ID* assigned to the IEEE 802.1x-authenticated user.

For examples of tunnel attributes, see the “[Configuring the Switch to Use Vendor-Specific RADIUS Attributes](#)” section on page 10-35.

802.1x Authentication with Per-User ACLs

You can enable per-user access control lists (ACLs) to provide different levels of network access and service to an 802.1x-authenticated user. When the RADIUS server authenticates a user connected to an 802.1x port, it retrieves the ACL attributes based on the user identity and sends them to the switch. The switch applies the attributes to the 802.1x port for the duration of the user session. The switch removes the per-user ACL configuration when the session is over, if authentication fails, or if a link-down condition occurs. The switch does not save RADIUS-specified ACLs in the running configuration. When the port is unauthorized, the switch removes the ACL from the port.

You can configure router ACLs and input port ACLs on the same switch. However, a port ACL takes precedence over a router ACL. If you apply input port ACL to an interface that belongs to a VLAN, the port ACL takes precedence over an input router ACL applied to the VLAN interface. Incoming packets received on the port to which a port ACL is applied are filtered by the port ACL. Incoming routed packets received on other ports are filtered by the router ACL. Outgoing routed packets are filtered by the router ACL. To avoid configuration conflicts, you should carefully plan the user profiles stored on the RADIUS server.

RADIUS supports per-user attributes, including vendor-specific attributes. These vendor-specific attributes (VSAs) are in octet-string format and are passed to the switch during the authentication process. The VSAs used for per-user ACLs are *inacl#<n>* for the ingress direction and *outacl#<n>* for the egress direction. MAC ACLs are supported only in the ingress direction. The switch supports VSAs only in the ingress direction. It does not support port ACLs in the egress direction on Layer 2 ports. For more information, see [Chapter 37, “Configuring Network Security with ACLs.”](#)

Use only the extended ACL syntax style to define the per-user configuration stored on the RADIUS server. When the definitions are passed from the RADIUS server, they are created by using the extended naming convention. However, if you use the Filter-Id attribute, it can point to a standard ACL.

You can use the Filter-Id attribute to specify an inbound or outbound ACL that is already configured on the switch. The attribute contains the ACL number followed by *.in* for ingress filtering or *.out* for egress filtering. If the RADIUS server does not allow the *.in* or *.out* syntax, the access list is applied to the outbound ACL by default. Because of limited support of Cisco IOS access lists on the switch, the Filter-Id attribute is supported only for IP ACLs numbered 1 to 199 and 1300 to 2699 (IP standard and IP extended ACLs).

Only one 802.1x-authenticated user is supported on a port. If the multiple-hosts mode is enabled on the port, the per-user ACL attribute is disabled for the associated port.

The maximum size of the per-user ACL is 4000 ASCII characters but is limited by the maximum size of RADIUS-server per-user ACLs.

For examples of vendor-specific attributes, see the [“Configuring the Switch to Use Vendor-Specific RADIUS Attributes” section on page 10-35](#). For more information about configuring ACLs, see [Chapter 37, “Configuring Network Security with ACLs.”](#)

To configure per-user ACLs, you need to perform these tasks:

- Enable AAA authentication.
- Enable AAA authorization by using the **network** keyword to allow interface configuration from the RADIUS server.
- Enable 802.1x authentication.
- Configure the user profile and VSAs on the RADIUS server.
- Configure the 802.1x port for single-host mode.



Note Per-user ACLs are supported only in single-host mode.

802.1x Authentication with Downloadable ACLs and Redirect URLs

You can download ACLs and redirect URLs from a RADIUS server to the switch during 802.1x authentication or MAC authentication bypass of the host. You can also download ACLs during web authentication.



Note A downloadable ACL is also referred to as a *dACL*.

If the host mode is single-host, MDA, or multiple-authentication mode, the switch modifies the source address of the ACL to be the host IP address.

You can apply the ACLs and redirect URLs to all the devices connected to the 802.1x-enabled port.

If no ACLs are downloaded during 802.1x authentication, the switch applies the static default ACL on the port to the host. On a voice VLAN port, the switch applies the ACL only to the phone.



Note If a downloadable ACL or redirect URL is configured for a client on the authentication server, a default port ACL on the connected client switch port must also be configured.

Cisco Secure ACS and Attribute-Value Pairs for the Redirect URL

The switch uses these *cisco-av-pair* VSAs:

- url-redirect is the HTTP to HTTPS URL.
- url-redirect-acl is the switch ACL name or number.

The switch uses the CiscoSecure-Defined-ACL AV pair to intercept an HTTP or HTTPS request from the endpoint device. The switch then forwards the client web browser to the specified redirect address. The url-redirect AV pair on the Cisco Secure ACS contains the URL to which the web browser is redirected. The url-redirect-acl AV pair contains the name or number of an ACL that specifies the HTTP or HTTPS traffic to redirect. Traffic that matches a permit ACE in the ACL is redirected.

**Note**

Define the URL redirect ACL and the default port ACL on the switch.

If a redirect URL configured for a client on the authentication server, a default port ACL on the connected client switch port must also be configured

Cisco Secure ACS and Attribute-Value Pairs for Downloadable ACLs

You can set the CiscoSecure-Defined-ACL Attribute-Value (AV) pair on the Cisco Secure ACS with the RADIUS cisco-av-pair vendor-specific attributes (VSAs). This pair specifies the names of the downloadable ACLs on the Cisco Secure ACS with the #ACL#-IP-name-number attribute.

- The *name* is the ACL name.
- The *number* is the version number (for example, 3f783768).

If a downloadable ACL is configured for a client on the authentication server, a default port ACL on the connected client switch port must also be configured.

If the default ACL is configured on the switch and the Cisco Secure ACS sends a host-access-policy to the switch, it applies the policy to traffic from the host connected to a switch port. If the policy does not apply, the switch applies the default ACL. If the Cisco Secure ACS sends the switch a downloadable ACL, this ACL takes precedence over the default ACL that is configured on the switch port. However, if the switch receives an host access policy from the Cisco Secure ACS but the default ACL is not configured, the authorization failure is declared.

For configuration details, see the [“Authentication Manager” section on page 11-8](#) and the [“Configuring 802.1x Authentication with Downloadable ACLs and Redirect URLs” section on page 11-62](#).

VLAN ID-based MAC Authentication

You can use VLAN ID-based MAC authentication if you wish to authenticate hosts based on a static VLAN ID instead of a downloadable VLAN. When you have a static VLAN policy configured on your switch, VLAN information is sent to an IAS (Microsoft) RADIUS server along with the MAC address of each host for authentication. The VLAN ID configured on the connected port is used for MAC authentication. By using VLAN ID-based MAC authentication with an IAS server, you can have a fixed number of VLANs in the network.

The feature also limits the number of VLANs monitored and handled by STP. The network can be managed as a fixed VLAN.

**Note**

This feature is not supported on Cisco ACS Server. (The ACS server ignores the sent VLAN-IDs for new hosts and only authenticates based on the MAC address.)

For configuration information, see the “[Configuring VLAN ID-based MAC Authentication](#)” section on page 11-64. Additional configuration is similar MAC authentication bypass, as described in the “[Configuring MAC Authentication Bypass](#)” section on page 11-57.

802.1x Authentication with Guest VLAN

You can configure a guest VLAN for each 802.1x port on the switch to provide limited services to clients, such as downloading the 802.1x client. These clients might be upgrading their system for 802.1x authentication, and some hosts, such as Windows 98 systems, might not be IEEE 802.1x-capable.

When you enable a guest VLAN on an 802.1x port, the switch assigns clients to a guest VLAN when the switch does not receive a response to its EAP request/identity frame or when EAPOL packets are not sent by the client.

The switch maintains the EAPOL packet history. If an EAPOL packet is detected on the interface during the lifetime of the link, the switch determines that the device connected to that interface is an IEEE 802.1x-capable supplicant, and the interface does not change to the guest VLAN state. EAPOL history is cleared if the interface link status goes down. If no EAPOL packet is detected on the interface, the interface changes to the guest VLAN state.

If the switch is trying to authorize an 802.1x-capable voice device and the AAA server is unavailable, the authorization attempt fails, but the detection of the EAPOL packet is saved in the EAPOL history. When the AAA server becomes available, the switch authorizes the voice device. However, the switch no longer allows other devices access to the guest VLAN. To prevent this situation, use one of these command sequences:

- Enter the **dot1x guest-vlan supplicant** global configuration command to allow access to the guest VLAN.
- Enter the **shutdown** interface configuration command followed by the **no shutdown** interface configuration command to restart the port.

Use a restricted VLAN to allow clients that failed authentication access to the network by entering the **dot1x auth-fail vlan** *vlan-id* interface configuration command.

If devices send EAPOL packets to the switch during the lifetime of the link, the switch no longer allows clients that fail authentication access to the guest VLAN.



Note

If an EAPOL packet is detected after the interface has changed to the guest VLAN, the interface reverts to an unauthorized state, and 802.1x authentication restarts.

Any number of 802.1x-incapable clients are allowed access when the switch port is moved to the guest VLAN. If an 802.1x-capable client joins the same port on which the guest VLAN is configured, the port is put into the unauthorized state in the user-configured access VLAN, and authentication is restarted.

Guest VLANs are supported on 802.1x ports in single-host or multiple-hosts mode.

You can configure any active VLAN except an RSPAN VLAN, a private VLAN, or a voice VLAN as an 802.1x guest VLAN. The guest VLAN feature is not supported on internal VLANs (routed ports) or trunk ports; it is supported only on access ports.

The switch supports *MAC authentication bypass*. When MAC authentication bypass is enabled on an 802.1x port, the switch can authorize clients based on the client MAC address when IEEE 802.1x authentication times out while waiting for an EAPOL message exchange. After detecting a client on an 802.1x port, the switch waits for an Ethernet packet from the client. The switch sends the authentication server a RADIUS-access/request frame with a username and password based on the MAC

address. If authorization succeeds, the switch grants the client access to the network. If authorization fails, the switch assigns the port to the guest VLAN if one is specified. For more information, see the [“IEEE 802.1x Authentication with MAC Authentication Bypass”](#) section on page 11-25.

For more information, see the [“Configuring a Guest VLAN”](#) section on page 11-51.

802.1x Authentication with Restricted VLAN

You can configure a restricted VLAN (also referred to as an *authentication failed VLAN*) for each IEEE 802.1x port on a switch stack or a switch to provide limited services to clients that cannot access the guest VLAN. These clients are 802.1x-compliant and cannot access another VLAN because they fail the authentication process. A restricted VLAN allows users without valid credentials in an authentication server (typically, visitors to an enterprise) to access a limited set of services. The administrator can control the services available to the restricted VLAN.



Note

You can configure a VLAN to be both the guest VLAN and the restricted VLAN if you want to provide the same services to both types of users.

Without this feature, the client attempts and fails authentication indefinitely, and the switch port remains in the spanning-tree blocking state. With this feature, you can configure the switch port to be in the restricted VLAN after a specified number of authentication attempts (the default value is 3 attempts).

The authenticator counts the failed authentication attempts for the client. When this count exceeds the configured maximum number of authentication attempts, the port moves to the restricted VLAN. The failed attempt count increments when the RADIUS server replies with either an *EAP failure* or an empty response without an EAP packet. When the port moves into the restricted VLAN, the failed attempt counter resets.

Users who fail authentication remain in the restricted VLAN until the next re-authentication attempt. A port in the restricted VLAN tries to re-authenticate at configured intervals (the default is 60 seconds). If re-authentication fails, the port remains in the restricted VLAN. If re-authentication is successful, the port moves either to the configured VLAN or to a VLAN sent by the RADIUS server. You can disable re-authentication. If you do this, the only way to restart the authentication process is for the port to receive a *link down* or *EAP logoff* event. We recommend that you keep re-authentication enabled if a client might connect through a hub. When a client disconnects from the hub, the port might not receive the *link down* or *EAP logoff* event.

After a port moves to the restricted VLAN, a simulated EAP success message is sent to the client. This prevents clients from indefinitely attempting authentication. Some clients (for example, devices running Windows XP) cannot implement DHCP without EAP success.

Restricted VLANs are supported only on 802.1x ports in single-host mode and on Layer 2 ports.

You can configure any active VLAN except an RSPAN VLAN, a primary private VLAN, or a voice VLAN as an 802.1x restricted VLAN. The restricted VLAN feature is not supported on internal VLANs (routed ports) or trunk ports; it is supported only on access ports.

This feature works with port security. As soon as the port is authorized, a MAC address is provided to port security. If port security does not permit the MAC address or if the maximum secure address count is reached, the port becomes unauthorized and error disabled.

Other port security features such as dynamic ARP Inspection, DHCP snooping, and IP source guard can be configured independently on a restricted VLAN.

For more information, see the [“Configuring a Restricted VLAN”](#) section on page 11-52.

802.1x Authentication with Inaccessible Authentication Bypass

Use the inaccessible authentication bypass feature, also referred to as *critical authentication* or the AAA *fail policy*, when the switch cannot reach the configured RADIUS servers and new hosts cannot be authenticated. You can configure the switch to connect those hosts to *critical ports*.

When a new host tries to connect to the critical port, that host is moved to a user-specified access VLAN, the *critical VLAN*. The administrator gives limited authentication to the hosts.

When the switch tries to authenticate a host connected to a critical port, the switch checks the status of the configured RADIUS server. If a server is available, the switch can authenticate the host. However, if all the RADIUS servers are unavailable, the switch grants network access to the host and puts the port in the *critical-authentication* state, which is a special case of the authentication state.

Support on Multiple-Authentication Ports

To support inaccessible bypass on multiple-authentication (multiauth) ports, you can use the **authentication event server dead action reinitialize vlan** *vlan-id*. When a new host tries to connect to the critical port, that port is reinitialized and all the connected hosts are moved to the user-specified access VLAN.

The **authentication event server dead action reinitialize vlan** *vlan-id* interface configuration command is supported on all host modes.

Authentication Results

The behavior of the inaccessible authentication bypass feature depends on the authorization state of the port:

- If the port is unauthorized when a host connected to a critical port tries to authenticate and all servers are unavailable, the switch puts the port in the critical-authentication state in the RADIUS-configured or user-specified access VLAN.
- If the port is already authorized and reauthentication occurs, the switch puts the critical port in the critical-authentication state in the current VLAN, which might be the one previously assigned by the RADIUS server.
- If the RADIUS server becomes unavailable during an authentication exchange, the current exchange times out, and the switch puts the critical port in the critical-authentication state during the next authentication attempt.

You can configure the critical port to reinitialize hosts and move them out of the critical VLAN when the RADIUS server is again available. When this is configured, all critical ports in the critical-authentication state are automatically re-authenticated. For more information, see the command reference for this release and the [“Configuring the Inaccessible Authentication Bypass Feature”](#) on page -54.

Feature Interactions

Inaccessible authentication bypass interacts with these features:

- Guest VLAN—Inaccessible authentication bypass is compatible with guest VLAN. When a guest VLAN is enabled on 802.1x port, the features interact as follows:
 - If at least one RADIUS server is available, the switch assigns a client to a guest VLAN when the switch does not receive a response to its EAP request/identity frame or when EAPOL packets are not sent by the client.
 - If all the RADIUS servers are not available and the client is connected to a critical port, the switch authenticates the client and puts the critical port in the critical-authentication state in the RADIUS-configured or user-specified access VLAN.
 - If all the RADIUS servers are not available and the client is not connected to a critical port, the switch might not assign clients to the guest VLAN if one is configured.
 - If all the RADIUS servers are not available and if a client is connected to a critical port and was previously assigned to a guest VLAN, the switch keeps the port in the guest VLAN.
- Restricted VLAN—If the port is already authorized in a restricted VLAN and the RADIUS servers are unavailable, the switch puts the critical port in the critical-authentication state in the restricted VLAN.
- 802.1x accounting—Accounting is not affected if the RADIUS servers are unavailable.
- Private VLAN—You can configure inaccessible authentication bypass on a private VLAN host port. The access VLAN must be a secondary private VLAN.
- Voice VLAN—Inaccessible authentication bypass is compatible with voice VLAN, but the RADIUS-configured or user-specified access VLAN and the voice VLAN must be different.
- Remote Switched Port Analyzer (RSPAN)—Do not configure an RSPAN VLAN as the RADIUS-configured or user-specified access VLAN for inaccessible authentication bypass.

In a switch stack, the stack master checks the status of the RADIUS servers by sending keepalive packets. When the status of a RADIUS server changes, the stack master sends the information to the stack members. The stack members can then check the status of RADIUS servers when re-authenticating critical ports.

If the new stack master is elected, the link between the switch stack and RADIUS server might change, and the new stack immediately sends keepalive packets to update the status of the RADIUS servers. If the server status changes from *dead* to *alive*, the switch re-authenticates all switch ports in the critical-authentication state.

When a member is added to the stack, the stack master sends the member the server status.

802.1x User Distribution

You can configure 802.1x user distribution to load-balance users with the same group name across multiple different VLANs.

The VLANs are either supplied by the RADIUS server or configured through the switch CLI under a VLAN group name.

- Configure the RADIUS server to send more than one VLAN name for a user. The multiple VLAN names can be sent as part of the response to the user. The 802.1x user distribution tracks all the users in a particular VLAN and achieves load balancing by moving the authorized user to the least populated VLAN.

- Configure the RADIUS server to send a VLAN group name for a user. The VLAN group name can be sent as part of the response to the user. You can search for the selected VLAN group name among the VLAN group names that you configured by using the switch CLI. If the VLAN group name is found, the corresponding VLANs under this VLAN group name are searched to find the least populated VLAN. Load balancing is achieved by moving the corresponding authorized user to that VLAN.



Note The RADIUS server can send the VLAN information in any combination of VLAN-IDs, VLAN names, or VLAN groups.

802.1x User Distribution Configuration Guidelines

- Confirm that at least one VLAN is mapped to the VLAN group.
- You can map more than one VLAN to a VLAN group.
- You can modify the VLAN group by adding or deleting a VLAN.
- When you clear an existing VLAN from the VLAN group name, none of the authenticated ports in the VLAN are cleared, but the mappings are removed from the existing VLAN group.
- If you clear the last VLAN from the VLAN group name, the VLAN group is cleared.
- You can clear a VLAN group even when the active VLANs are mapped to the group. When you clear a VLAN group, none of the ports or users that are in the authenticated state in any VLAN within the group are cleared, but the VLAN mappings to the VLAN group are cleared.

For more information, see the [“802.1x User Distribution” section on page 11-22](#).

IEEE 802.1x Authentication with Voice VLAN Ports

A voice VLAN port is a special access port associated with two VLAN identifiers:

- VVID to carry voice traffic to and from the IP phone. The VVID is used to configure the IP phone connected to the port.
- PVID to carry the data traffic to and from the workstation connected to the switch through the IP phone. The PVID is the native VLAN of the port.

The IP phone uses the VVID for its voice traffic, regardless of the authorization state of the port. This allows the phone to work independently of IEEE 802.1x authentication.

In single-host mode, only the IP phone is allowed on the voice VLAN. In multiple-hosts mode, additional clients can send traffic on the voice VLAN after a supplicant is authenticated on the PVID. When multiple-hosts mode is enabled, the supplicant authentication affects both the PVID and the VVID.



Note If an IP phone and PC are connected to a switchport, and the port is configured in single- or multi-host mode, we do not recommend configuring that port in standalone MAC authentication bypass mode. We recommend only using MAC authentication bypass as a fallback method to 802.1x authentication with the timeout period set to the default of five seconds.

A voice VLAN port becomes active when there is a link, and the device MAC address appears after the first CDP message from the IP phone. Cisco IP phones do not relay CDP messages from other devices. As a result, if several IP phones are connected in series, the switch recognizes only the one directly connected to it. When IEEE 802.1x authentication is enabled on a voice VLAN port, the switch drops packets from unrecognized IP phones more than one hop away.

When IEEE 802.1x authentication is enabled on a port, you cannot configure a port VLAN that is equal to a voice VLAN.

Note

If you enable IEEE 802.1x authentication on an access port on which a voice VLAN is configured and to which a Cisco IP Phone is connected, the Cisco IP phone loses connectivity to the switch for up to 30 seconds.

For more information about voice VLANs, see [Chapter 17, “Configuring Voice VLAN.”](#)

IEEE 802.1x Authentication with Port Security

You can configure an IEEE 802.1x port with port security in either single-host or multiple-hosts mode. (You also must configure port security on the port by using the **switchport port-security** interface configuration command.) When you enable port security and IEEE 802.1x authentication on a port, IEEE 802.1x authentication authenticates the port, and port security manages network access for all MAC addresses, including that of the client. You can then limit the number or group of clients that can access the network through an IEEE 802.1x port.

These are some examples of the interaction between IEEE 802.1x authentication and port security on the switch:

- When a client is authenticated, and the port security table is not full, the client MAC address is added to the port security list of secure hosts. The port then proceeds to come up normally.

When a client is authenticated and manually configured for port security, it is guaranteed an entry in the secure host table (unless port security static aging has been enabled).

A security violation occurs if the client is authenticated, but the port security table is full. This can happen if the maximum number of secure hosts has been statically configured or if the client ages out of the secure host table. If the client address is aged, its place in the secure host table can be taken by another host.

If the security violation is caused by the first authenticated host, the port becomes error-disabled and immediately shuts down.

The port security violation modes determine the action for security violations. For more information, see the [“Security Violations” section on page 28-10](#).

- When you manually remove an IEEE 802.1x client address from the port security table by using the **no switchport port-security mac-address mac-address** interface configuration command, you should re-authenticate the IEEE 802.1x client by using the **dot1x re-authenticate interface interface-id** privileged EXEC command.
- When an IEEE 802.1x client logs off, the port changes to an unauthenticated state, and all dynamic entries in the secure host table are cleared, including the entry for the client. Normal authentication then takes place.
- If the port is administratively shut down, the port becomes unauthenticated, and all dynamic entries are removed from the secure host table.

- Port security and a voice VLAN can be configured simultaneously on an IEEE 802.1x port that is in either single-host or multiple-hosts mode. Port security applies to both the voice VLAN identifier (VVID) and the port VLAN identifier (PVID).

You can configure the **authentication violation** or **dot1x violation-mode** interface configuration command so that a port shuts down, generates a syslog error, or discards packets from a new device when it connects to an IEEE 802.1x-enabled port or when the maximum number of allowed devices have been authenticated. For more information see the [“Maximum Number of Allowed Devices Per Port”](#) section on page 11-39 and the command reference for this release.

For more information about enabling port security on your switch, see the [“Configuring Port Security”](#) section on page 28-8.

IEEE 802.1x Authentication with Wake-on-LAN

The IEEE 802.1x authentication with wake-on-LAN (WoL) feature allows dormant PCs to be powered when the switch receives a specific Ethernet frame, known as the *magic packet*. You can use this feature in environments where administrators need to connect to systems that have been powered down.

When a host that uses WoL is attached through an IEEE 802.1x port and the host powers off, the IEEE 802.1x port becomes unauthorized. The port can only receive and send EAPOL packets, and WoL magic packets cannot reach the host. When the PC is powered off, it is not authorized, and the switch port is not opened.

When the switch uses IEEE 802.1x authentication with WoL, the switch forwards traffic to unauthorized IEEE 802.1x ports, including magic packets. While the port is unauthorized, the switch continues to block ingress traffic other than EAPOL packets. The host can receive packets but cannot send packets to other devices in the network.



Note

If PortFast is not enabled on the port, the port is forced to the bidirectional state.

When you configure a port as unidirectional by using the **dot1x control-direction in** interface configuration command, the port changes to the spanning-tree forwarding state. The port can send packets to the host but cannot receive packets from the host.

When you configure a port as bidirectional by using the **dot1x control-direction both** interface configuration command, the port is access-controlled in both directions. The port does not receive packets from or send packets to the host.

IEEE 802.1x Authentication with MAC Authentication Bypass

You can configure the switch to authorize clients based on the client MAC address (see [Figure 11-2](#) on page 11-5) by using the MAC authentication bypass feature. For example, you can enable this feature on IEEE 802.1x ports connected to devices such as printers.

If IEEE 802.1x authentication times out while waiting for an EAPOL response from the client, the switch tries to authorize the client by using MAC authentication bypass.

When the MAC authentication bypass feature is enabled on an IEEE 802.1x port, the switch uses the MAC address as the client identity. The authentication server has a database of client MAC addresses that are allowed network access. After detecting a client on an IEEE 802.1x port, the switch waits for an Ethernet packet from the client. The switch sends the authentication server a RADIUS-access/request

frame with a username and password based on the MAC address. If authorization succeeds, the switch grants the client access to the network. If authorization fails, the switch assigns the port to the guest VLAN if one is configured.

If an EAPOL packet is detected on the interface during the lifetime of the link, the switch determines that the device connected to that interface is an IEEE 802.1x-capable supplicant and uses IEEE 802.1x authentication (not MAC authentication bypass) to authorize the interface. EAPOL history is cleared if the interface link status goes down.

If the switch already authorized a port by using MAC authentication bypass and detects an IEEE 802.1x supplicant, the switch does not unauthorize the client connected to the port. When re-authentication occurs, the switch uses IEEE 802.1x authentication as the preferred re-authentication process if the previous session ended because the Termination-Action RADIUS attribute value is `DEFAULT`.

Clients that were authorized with MAC authentication bypass can be re-authenticated. The re-authentication process is the same as that for clients that were authenticated with IEEE 802.1x. During re-authentication, the port remains in the previously assigned VLAN. If re-authentication is successful, the switch keeps the port in the same VLAN. If re-authentication fails, the switch assigns the port to the guest VLAN, if one is configured.

If re-authentication is based on the Session-Timeout RADIUS attribute (Attribute[27]) and the Termination-Action RADIUS attribute (Attribute [29]) and if the Termination-Action RADIUS attribute (Attribute [29]) action is *Initialize*, (the attribute value is `DEFAULT`), the MAC authentication bypass session ends, and connectivity is lost during re-authentication. If MAC authentication bypass is enabled and the IEEE 802.1x authentication times out, the switch uses the MAC authentication bypass feature to initiate re-authorization. For more information about these AV pairs, see RFC 3580, “IEEE 802.1X Remote Authentication Dial In User Service (RADIUS) Usage Guidelines.”

MAC authentication bypass interacts with the features:

- IEEE 802.1x authentication—You can enable MAC authentication bypass only if IEEE 802.1x authentication is enabled on the port.
- Guest VLAN—If a client has an invalid MAC address identity, the switch assigns the client to a guest VLAN if one is configured.
- Restricted VLAN—This feature is not supported when the client connected to an IEEE 802.1x port is authenticated with MAC authentication bypass.
- Port security—See the “[IEEE 802.1x Authentication with Port Security](#)” section on page 11-24.
- Voice VLAN—See the “[IEEE 802.1x Authentication with Voice VLAN Ports](#)” section on page 11-23.
- VLAN Membership Policy Server (VMPS)—IEEE802.1x and VMPS are mutually exclusive.
- Private VLAN—You can assign a client to a private VLAN.
- Network admission control (NAC) Layer 2 IP validation—This feature takes effect after an IEEE 802.1x port is authenticated with MAC authentication bypass, including hosts in the exception list.

For more configuration information, see the “[Authentication Manager](#)” section on page 11-8.

Network Admission Control Layer 2 IEEE 802.1x Validation

The switch supports the Network Admission Control (NAC) Layer 2 IEEE 802.1x validation, which checks the antivirus condition or *posture* of endpoint systems or clients before granting the devices network access. With NAC Layer 2 IEEE 802.1x validation, you can do these tasks:

- Download the Session-Timeout RADIUS attribute (Attribute[27]) and the Termination-Action RADIUS attribute (Attribute[29]) from the authentication server.
- Set the number of seconds between re-authentication attempts as the value of the Session-Timeout RADIUS attribute (Attribute[27]) and get an access policy against the client from the RADIUS server.
- Set the action to be taken when the switch tries to re-authenticate the client by using the Termination-Action RADIUS attribute (Attribute[29]). If the value is the *DEFAULT* or is not set, the session ends. If the value is RADIUS-Request, the re-authentication process starts.
- View the NAC posture token, which shows the posture of the client, by using the **show dot1x** privileged EXEC command.
- Configure secondary private VLANs as guest VLANs.

Configuring NAC Layer 2 IEEE 802.1x validation is similar to configuring IEEE 802.1x port-based authentication except that you must configure a posture token on the RADIUS server. For information about configuring NAC Layer 2 IEEE 802.1x validation, see the [“Configuring NAC Layer 2 IEEE 802.1x Validation” section on page 11-59](#) and the [“Configuring Periodic Re-Authentication” section on page 11-46](#).

For more information about NAC, see the *Network Admission Control Software Configuration Guide*. For more configuration information, see the [“Authentication Manager” section on page 11-8](#).

Flexible Authentication Ordering

You can use flexible authentication ordering to configure the order of methods that a port uses to authenticate a new host. MAC authentication bypass and 802.1x can be the primary or secondary authentication methods, and web authentication can be the fallback method if either or both of those authentication attempts fail. For more information see the [“Configuring Flexible Authentication Ordering” section on page 11-65](#).

Open1x Authentication

Open1x authentication allows a device access to a port before that device is authenticated. When open authentication is configured, a new host on the port can only send traffic to the switch. After the host is authenticated, the policies configured on the RADIUS server are applied to that host.

You can configure open authentication with these scenarios:

- Single-host mode with open authentication—Only one user is allowed network access before and after authentication.
- MDA mode with open authentication—Only one user in the voice domain and one user in the data domain are allowed.
- Multiple-hosts mode with open authentication—Any host can access the network.
- Multiple-authentication mode with open authentication—Similar to MDA, except multiple hosts can be authenticated.

For more information see the [“Configuring the Host Mode” section on page 11-45](#).

Use case of Open1x Authentication

This is based on a scenario where the end host/server is configured for High Availability (HA) and secondary host's network link remains down until its role becomes active. i.e the end host/server and secondary host use the same IP address in Active role but have different MAC address.

When secondary host's network link comes up, with HA on end device, authentication is triggered on the respective switch port.

However, during the process of authentication on switch port (assuming PortFast is already enabled), Gratuitous ARP (GARP) requests sent by end host (with new MAC address) will be dropped by switch (This is an expected behavior during closed authentication mode). This could further result in blackholing traffic destined for that specific IP due to obsolete ARP entry present, for that specific IP, on other devices in same VLAN including the gateway switch/router.

That ARP entry remains obsolete, unless the local cache is cleared manually for that specific host IP (HA) or a new ARP request is received from the end host (source of HA IP).

This situation can be avoided using Open1x Authentication with pre-authorized ACL/DACLs.

Multidomain Authentication

The switch supports multidomain authentication (MDA), which allows both a data device and voice device, such as an IP phone (Cisco or non-Cisco), to authenticate on the same switch port. The port is divided into a data domain and a voice domain.

MDA does not enforce the order of device authentication. However, for best results, we recommend that a voice device is authenticated before a data device on an MDA-enabled port.

Follow these guidelines for configuring MDA:

- To configure a switch port for MDA, see the [“Configuring the Host Mode” section on page 11-45](#).
- You must configure the voice VLAN for the IP phone when the host mode is set to multidomain. For more information, see [Chapter 17, “Configuring Voice VLAN.”](#)
- Voice VLAN assignment on an MDA-enabled port is supported.



Note If you use a dynamic VLAN to assign a voice VLAN on an MDA-enabled switch port, the voice device fails authorization.

- To authorize a voice device, the AAA server must be configured to send a Cisco Attribute-Value (AV) pair attribute with a value of `device-traffic-class=voice`. Without this value, the switch treats the voice device as a data device.
- The guest VLAN and restricted VLAN features only apply to the data devices on an MDA-enabled port. The switch treats a voice device that fails authorization as a data device.
- If more than one device attempts authorization on either the voice or the data domain of a port, it is error disabled.
- Until a device is authorized, the port drops its traffic. Non-Cisco IP phones or voice devices are allowed into both the data and voice VLANs. The data VLAN allows the voice device to contact a DHCP server to obtain an IP address and acquire the voice VLAN information. After the voice device starts sending on the voice VLAN, its access to the data VLAN is blocked.
- A voice device MAC address that is binding on the data VLAN is not counted towards the port security MAC address limit.

- You can use dynamic VLAN assignment from a RADIUS server only for data devices.
- MDA can use MAC authentication bypass as a fallback mechanism to allow the switch port to connect to devices that do not support IEEE 802.1x authentication. For more information, see the “MAC Authentication Bypass” section on page 11-38.
- When a *data* or a *voice* device is detected on a port, its MAC address is blocked until authorization succeeds. If the authorization fails, the MAC address remains blocked for 5 minutes.
- If more than five devices are detected on the *data* VLAN or more than one voice device is detected on the *voice* VLAN while a port is unauthorized, the port is error disabled.
- When a port host mode is changed from single- or multihost to multidomain mode, an authorized data device remains authorized on the port. However, a Cisco IP phone that has been allowed on the port voice VLAN is automatically removed and must be reauthenticated on that port.
- Active fallback mechanisms such as guest VLAN and restricted VLAN remain configured after a port changes from single- or multihost mode to multidomain mode.
- Switching a port host mode from multidomain to single- or multihost mode removes all authorized devices from the port.
- If a data domain is authorized first and placed in the guest VLAN, non-IEEE 802.1x-capable voice devices need to tag their packets on the voice VLAN to trigger authentication.
- We do not recommend per-user ACLs with an MDA-enabled port. An authorized device with a per-user ACL policy might impact traffic on both the voice and data VLANs of the port. If used, only one device on the port should enforce per-user ACLs.

802.1x Supplicant and Authenticator Switches with Network Edge Access Topology (NEAT)

The Network Edge Access Topology (NEAT) feature extends identity to areas outside the wiring closet (such as conference rooms). This allows any type of device to authenticate on the port.

- 802.1x switch supplicant: You can configure a switch to act as a supplicant to another switch by using the 802.1x supplicant feature. This configuration is helpful in a scenario, where, for example, a switch is outside a wiring closet and is connected to an upstream switch through a trunk port. A switch configured with the 802.1x switch supplicant feature authenticates with the upstream switch for secure connectivity. Once the supplicant switch authenticates successfully the port mode changes from access to trunk.
- If the access VLAN is configured on the authenticator switch, it becomes the native VLAN for the trunk port after successful authentication.

You can enable MDA or multiauth mode on the authenticator switch interface that connects to one more supplicant switches. Multihost mode is not supported on the authenticator switch interface.

Use the **dot1x supplicant force-multicast** global configuration command on the supplicant switch for Network Edge Access Topology (NEAT) to work in all host modes.

- Host Authorization: Ensures that only traffic from authorized hosts (connecting to the switch with supplicant) is allowed on the network. The switches use Client Information Signalling Protocol (CISP) to send the MAC addresses connecting to the supplicant switch to the authenticator switch, as shown in [Figure 11-6](#).
- Auto enablement: Automatically enables trunk configuration on the authenticator switch, allowing user traffic from multiple VLANs coming from supplicant switches. Configure the `cisco-av-pair as device-traffic-class=switch` at the ACS. (You can configure this under the `group` or the `user` settings.)

Figure 11-6 Authenticator and Supplicant Switch using CISP

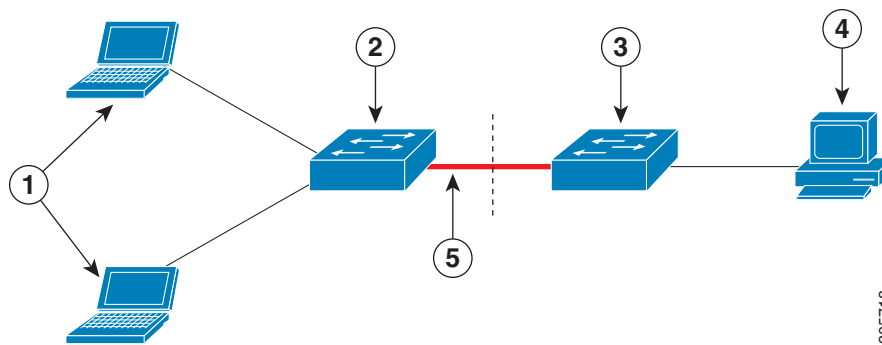

1	Workstations (clients)	2	Supplicant switch (outside wiring closet)
3	Authenticator switch	4	Access control server (ACS)
5	Trunk port		

Guidelines

- You can configure NEAT ports with the same configurations as the other authentication ports. When the supplicant switch authenticates, the port mode is changed from *access* to *trunk* based on the switch vendor-specific attributes (VSAs). (`device-traffic-class=switch`).
- The VSA changes the authenticator switch port mode from access to trunk and enables 802.1x trunk encapsulation and the access VLAN if any would be converted to a native trunk VLAN. VSA does not change any of the port configurations on the supplicant.
- To change the host mode *and* the apply a standard port configuration on the authenticator switch port, you can also use AutoSmart ports user-defined macros, instead of the switch VSA. This allows you to remove unsupported configurations on the authenticator switch port and to change the port mode from *access* to *trunk*. For more information, see [Chapter 14, “Configuring Auto Smartports Macros.”](#)

For more information, see the [“Configuring an Authenticator and a Supplicant Switch with NEAT”](#) section on page 11-60.

Voice Aware 802.1x Security

You use the voice aware 802.1x security feature to configure the switch to disable only the VLAN on which a security violation occurs, whether it is a data or voice VLAN. In previous releases, when an attempt to authenticate the data client caused a security violation, the entire port shut down, resulting in a complete loss of connectivity.

You can use this feature in IP phone deployments where a PC is connected to the IP phone. A security violation found on the data VLAN results in the shutdown of only the data VLAN. The traffic on the voice VLAN flows through the switch without interruption.

For information on configuring voice aware 802.1x security, see the [“Configuring Voice Aware 802.1x Security”](#) section on page 11-40.

Common Session ID

Authentication manager uses a single session ID (referred to as a common session ID) for a client no matter which authentication method is used. This ID is used for all reporting purposes, such as the show commands and MIBs. The session ID appears with all per-session syslog messages.

The session ID includes:

- The IP address of the Network Access Device (NAD)
- A monotonically increasing unique 32 bit integer
- The session start time stamp (a 32 bit integer)

This example shows how the session ID appears in the output of the show authentication command. The session ID in this example is 160000050000000B288508E5:

```
Switch# show authentication sessions
Interface  MAC Address      Method  Domain  Status      Session ID
Fa4/0/4    0000.0000.0203  mab     DATA   Authz Success 160000050000000B288508E5
```

This is an example of how the session ID appears in the syslog output. The session ID in this example is also 160000050000000B288508E5:

```
1w0d: %AUTHMGR-5-START: Starting 'mab' for client (0000.0000.0203) on Interface Fa4/0/4
AuditSessionID 160000050000000B288508E5
1w0d: %MAB-5-SUCCESS: Authentication successful for client (0000.0000.0203) on Interface
Fa4/0/4 AuditSessionID 160000050000000B288508E5
1w0d: %AUTHMGR-7-RESULT: Authentication result 'success' from 'mab' for client
(0000.0000.0203) on Interface Fa4/0/4 AuditSessionID 160000050000000B288508E5
```

The session ID is used by the NAD, the AAA server, and other report-analyzing applications to identify the client. The ID appears automatically. No configuration is required.

Understanding Media Access Control Security and MACsec Key Agreement

Media Access Control Security (MACsec), defined in 802.1AE, provides MAC-layer encryption over wired networks by using out-of-band methods for encryption keying. The MACsec Key Agreement (MKA) Protocol provides the required session keys and manages the required encryption keys. MKA and MACsec are implemented after successful using the 802.1x Extensible Authentication Protocol (EAP) framework. On the Catalyst 3750-X and 3560-X switches running Cisco IOS Release 12.2(53)SE2, only host facing links (links between network access devices and endpoint devices such as a PC or IP phone) can be secured using MACsec.

A switch using MACsec accepts either MACsec or non-MACsec frames, depending on the policy associated with the client. MACsec frames are encrypted and protected with an integrity check value (ICV). When the switch receives frames from the client, it decrypts them and calculates the correct ICV by using session keys provided by MKA. The switch compares that ICV to the ICV within the frame. If they are not identical, the frame is dropped. The switch also encrypts and adds an ICV to any frames sent over the secured port (the access point used to provide the secure MAC service to a client) using the current session key.

The MKA Protocol manages the encryption keys used by the underlying MACsec protocol. The basic requirements of MKA are defined in 802.1x-REV. The MKA Protocol extends 802.1x to allow peer discovery with confirmation of mutual authentication and sharing of MACsec secret keys to protect data exchanged by the peers.

The EAP framework implements MKA as a newly defined EAP-over-LAN (EAPOL) packet. EAP authentication produces a master session key (MSK) shared by both partners in the data exchange. Entering the EAP session ID generates a secure connectivity association key name (CKN). Because the switch is the authenticator, it is also the key server, generating a random 128-bit secure association key (SAK), which it sends it to the client partner. The client is never a key server and can only interact with a single MKA entity, the key server. After key derivation and generation, the switch sends periodic transports to the partner at a default interval of 2 seconds.

The packet body in an EAPOL Protocol Data Unit (PDU) is referred to as a MACsec Key Agreement PDU (MKPDU). MKA sessions and participants are deleted when the MKA lifetime (6 seconds) passes with no MKPDU received from a participant. For example, if a client disconnects, the participant on the switch continues to operate MKA until 6 seconds have elapsed after the last MKPDU is received from the client.

These sections provide more details:

- [MKA Policies, page 11-32](#)
- [Virtual Ports, page 11-32](#)
- [MACsec and Stacking, page 11-33](#)
- [MACsec, MKA and 802.1x Host Modes, page 11-33](#)
- [MKA Statistics, page 11-34](#)

MKA Policies

You apply a defined MKA policy to an interface to enable MKA on the interface. Removing the MKA policy disables MKA on that interface. You can configure these options:

- Policy name, not to exceed 16 ASCII characters.
- Confidentiality (encryption) offset of 0, 30, or 50 bytes for each physical interface.
- Replay protection. You can configure MACsec window size, as defined by the number of out-of-order frames that are accepted. This value is used while installing the security associations in the MACsec. A value of 0 means that frames are accepted only in the correct order.

Virtual Ports

You use virtual ports for multiple secured connectivity associations on a single physical port. Each connectivity association (pair) represents a virtual port, with a maximum of two virtual ports per physical port. Only one of the two virtual ports can be part of a data VLAN; the other must externally tag its packets for the voice VLAN. You cannot simultaneously host secured and unsecured sessions in the same VLAN on the same port. Because of this limitation, 802.1x multiple authentication mode is not supported.

The exception to this limitation is in multiple-host mode when the first MACsec supplicant is successfully authenticated and connected to a hub that is connected to the switch. A non-MACsec host connected to the hub can send traffic without authentication because it is in multiple-host mode.

Virtual ports represent an arbitrary identifier for a connectivity association and have no meaning outside the MKA Protocol. A virtual port corresponds to a separate logical port ID. Valid port IDs for a virtual port are 0x0002 to 0xFFFF. Each virtual port receives a unique secure channel identifier (SCI) based on the MAC address of the physical interface concatenated with a 16-bit port ID.

MACsec and Stacking

A Catalyst 3750-X stack master running MACsec maintains the configuration files that show which ports on a member switch support MACsec. The stack master performs these functions:

- Processes secure channel and secure association creation and deletion.
- Sends secure association service requests to the stack members.
- Processes packet number and replay-window information from local or remote ports and notifies the key management protocol.
- Sends MACsec initialization requests with the globally configured options to new switches that are added to the stack.
- Sends any per-port configuration to the member switches.

A member switch performs these functions:

- Processes MACsec initialization requests from the stack master.
- Processes MACsec service requests sent by the stack master.
- Sends information about local ports to the stack master.

In case of a stack master changeover, all secured sessions are brought down and then reestablished. The authentication manager recognizes any secured sessions and initiates teardown of these sessions.

MACsec, MKA and 802.1x Host Modes

You can use MACsec and the MKA Protocol with 802.1x single-host mode, multiple-host mode, or Multi Domain Authentication (MDA) mode. Multiple authentication mode is not supported.



Note

Although the software supports MDA mode, there are no IP phones that support MACsec and MKA.

Single-Host Mode

Figure 11-7 shows how a single EAP authenticated session is secured by MACsec by using MKA.

Figure 11-7 MACsec in Single-Host Mode with a Secured Data Session

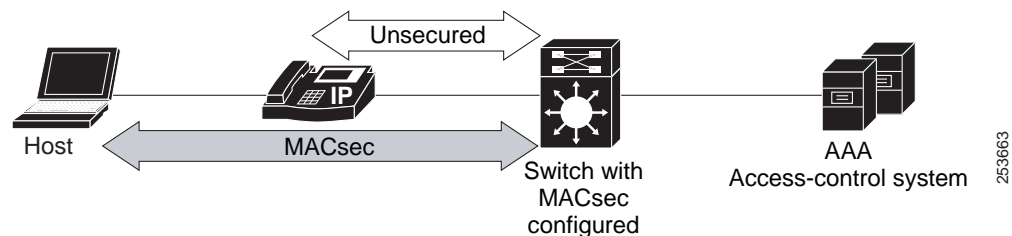

The same switch port hosts an unsecured phone session using CDP bypass. Since CDP bypass mode bypasses authentication to provide access based only on device type, the switch does not attempt to enter into an MKA exchange with the phone. If a voice VLAN is configured, CDP packets bypass MAC sec. For secure voice access, you should use MDA mode.

Multiple-Host Mode

In standard (not 802.1x REV) 802.1x multiple-host mode, a port is open or closed based on a single authentication. If one user, the primary secured client services client host, is authenticated, the same level of network access is provided to any host connected to the same port. If a secondary host is a MACsec supplicant, it cannot be authenticated and traffic would not flow. A secondary host that is a non-MACsec host can send traffic to the network without authentication because it is in multiple-host mode. See [Figure 11-8](#).

Figure 11-8 MACsec in Standard Multiple-Host Mode - Unsecured

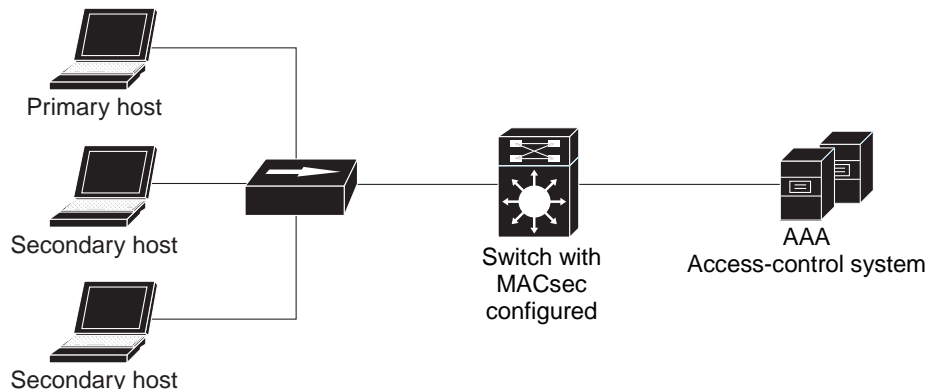

MKA Statistics

Some MKA counters are aggregated globally, while others are updated both globally and per session. You can also obtain information about the status of MKA sessions.

Configuring 802.1x Authentication

These sections contain this configuration information:

- [Default 802.1x Authentication Configuration, page 11-35](#)
- [802.1x Authentication Configuration Guidelines, page 11-36](#)
- [Configuring 802.1x Readiness Check, page 11-39 \(optional\)](#)
- [Configuring Voice Aware 802.1x Security, page 11-40 \(optional\)](#)
- [Configuring the Switch-to-RADIUS-Server Communication, page 11-43 \(required\)](#)
- [Configuring 802.1x Violation Modes, page 11-41](#)
- [Configuring 802.1x Authentication, page 11-42](#)
- [Configuring the Host Mode, page 11-45 \(optional\)](#)
- [Configuring Periodic Re-Authentication, page 11-46 \(optional\)](#)
- [Manually Re-Authenticating a Client Connected to a Port, page 11-47 \(optional\)](#)
- [Changing the Quiet Period, page 11-47 \(optional\)](#)
- [Changing the Switch-to-Client Retransmission Time, page 11-48 \(optional\)](#)
- [Setting the Switch-to-Client Frame-Retransmission Number, page 11-48 \(optional\)](#)

- [Setting the Re-Authentication Number, page 11-49](#) (optional)
- [Enabling MAC Move, page 11-50](#) (optional)
- [Configuring 802.1x Accounting, page 11-50](#) (optional)
- [Configuring a Guest VLAN, page 11-51](#) (optional)
- [Configuring a Restricted VLAN, page 11-52](#) (optional)
- [Configuring the Inaccessible Authentication Bypass Feature, page 11-54](#) (optional)
- [Configuring 802.1x Authentication with WoL, page 11-57](#) (optional)
- [Configuring MAC Authentication Bypass, page 11-57](#) (optional)
- [Configuring 802.1x User Distribution, page 11-58](#) (optional)
- [Configuring NAC Layer 2 IEEE 802.1x Validation, page 11-59](#) (optional)
- [Resetting the 802.1x Authentication Configuration to the Default Values, page 11-67](#) (optional)
- [Disabling 802.1x Authentication on the Port, page 11-67](#) (optional)
- [Configuring an Authenticator and a Supplicant Switch with NEAT, page 11-60](#) (optional)
- [Configuring 802.1x Authentication with Downloadable ACLs and Redirect URLs, page 11-62](#) (optional)
- [Configuring VLAN ID-based MAC Authentication, page 11-64](#) (optional)
- [Configuring Flexible Authentication Ordering, page 11-65](#) (optional)
- [Configuring Open1x, page 11-65](#) (optional)
- [Configuring a Web Authentication Local Banner, page 11-66](#) (optional)
- [Disabling 802.1x Authentication on the Port, page 11-67](#) (optional)
- [Resetting the 802.1x Authentication Configuration to the Default Values, page 11-67](#) (optional)
- [Configuring MKA and MACsec, page 11-68](#) (optional)

Default 802.1x Authentication Configuration

Table 11-4 Default 802.1x Authentication Configuration

Feature	Default Setting
Switch 802.1x enable state	Disabled.
Per-port 802.1x enable state	Disabled (force-authorized). The port sends and receives normal traffic without 802.1x-based authentication of the client.
AAA	Disabled.
RADIUS server <ul style="list-style-type: none"> • IP address • UDP authentication port • Key 	<ul style="list-style-type: none"> • None specified. • 1812. • None specified.
Host mode	Single-host mode.
Control direction	Bidirectional control.

Table 11-4 Default 802.1x Authentication Configuration (continued)

Feature	Default Setting
Periodic re-authentication	Disabled.
Number of seconds between re-authentication attempts	3600 seconds.
Re-authentication number	2 times (number of times that the switch restarts the authentication process before the port changes to the unauthorized state).
Quiet period	60 seconds (number of seconds that the switch remains in the quiet state following a failed authentication exchange with the client).
Retransmission time	30 seconds (number of seconds that the switch should wait for a response to an EAP request/identity frame from the client before resending the request).
Maximum retransmission number	2 times (number of times that the switch will send an EAP-request/identity frame before restarting the authentication process).
Client timeout period	30 seconds (when relaying a request from the authentication server to the client, the amount of time the switch waits for a response before resending the request to the client.)
Authentication server timeout period	30 seconds (when relaying a response from the client to the authentication server, the amount of time the switch waits for a reply before resending the response to the server.) You can change this timeout period by using the dot1x timeout server-timeout interface configuration command.
Guest VLAN	None specified.
Inaccessible authentication bypass	Disabled.
Restricted VLAN	None specified.
Authenticator (switch) mode	None specified.
MAC authentication bypass	Disabled.
MACsec and MKA	Disabled. No MKA policies are configured.

802.1x Authentication Configuration Guidelines

This section has configuration guidelines for these features:

- [802.1x Authentication, page 11-36](#)
- [VLAN Assignment, Guest VLAN, Restricted VLAN, and Inaccessible Authentication Bypass, page 11-38](#)
- [MAC Authentication Bypass, page 11-38](#)
- [Maximum Number of Allowed Devices Per Port, page 11-39](#)

802.1x Authentication

These are the 802.1x authentication configuration guidelines:

- When 802.1x authentication is enabled, ports are authenticated before any other Layer 2 or Layer 3 features are enabled.

- If you try to change the mode of an 802.1x-enabled port (for example, from access to trunk), an error message appears, and the port mode is not changed.
- If the VLAN to which an 802.1x-enabled port is assigned changes, this change is transparent and does not affect the switch. For example, this change occurs if a port is assigned to a RADIUS server-assigned VLAN and is then assigned to a different VLAN after re-authentication.

If the VLAN to which an 802.1x port is assigned to shut down, disabled, or removed, the port becomes unauthorized. For example, the port is unauthorized after the access VLAN to which a port is assigned shuts down or is removed.

- The 802.1x protocol is supported on Layer 2 static-access ports, voice VLAN ports, and Layer 3 routed ports, but it is not supported on these port types:
 - Trunk port—If you try to enable 802.1x authentication on a trunk port, an error message appears, and 802.1x authentication is not enabled. If you try to change the mode of an 802.1x-enabled port to trunk, an error message appears, and the port mode is not changed.
 - Dynamic ports—A port in dynamic mode can negotiate with its neighbor to become a trunk port. If you try to enable 802.1x authentication on a dynamic port, an error message appears, and 802.1x authentication is not enabled. If you try to change the mode of an 802.1x-enabled port to dynamic, an error message appears, and the port mode is not changed.
 - Dynamic-access ports—If you try to enable 802.1x authentication on a dynamic-access (VLAN Query Protocol [VQP]) port, an error message appears, and 802.1x authentication is not enabled. If you try to change an 802.1x-enabled port to dynamic VLAN assignment, an error message appears, and the VLAN configuration is not changed.
 - EtherChannel port—Do not configure a port that is an active or a not-yet-active member of an EtherChannel as an 802.1x port. If you try to enable 802.1x authentication on an EtherChannel port, an error message appears, and 802.1x authentication is not enabled.
 - Switched Port Analyzer (SPAN) and Remote SPAN (RSPAN) destination ports—You can enable 802.1x authentication on a port that is a SPAN or RSPAN destination port. However, 802.1x authentication is disabled until the port is removed as a SPAN or RSPAN destination port. You can enable 802.1x authentication on a SPAN or RSPAN source port.
- Before globally enabling 802.1x authentication on a switch by entering the **dot1x system-auth-control** global configuration command, remove the EtherChannel configuration from the interfaces on which 802.1x authentication and EtherChannel are configured.
- If you are using a device running the Cisco Access Control Server (ACS) application for IEEE 802.1x authentication with EAP-Transparent LAN Services (TLS) and EAP-MD5, make sure that the device is running ACS Version 3.2.1 or later.
- When IP phones are connected to an 802.1x-enabled switch port that is in single host mode, the switch grants the phones network access without authenticating them. We recommend that you use multidomain authentication (MDA) on the port to authenticate both a data device and a voice device, such as an IP phone.



Note Only Catalyst 3750, 3560, and 2960 switches support CDP bypass. The Catalyst 3750-X, 3560-X, 3750-E, and 3560-E switches do not support CDP bypass.

VLAN Assignment, Guest VLAN, Restricted VLAN, and Inaccessible Authentication Bypass

These are the configuration guidelines for VLAN assignment, guest VLAN, restricted VLAN, and inaccessible authentication bypass:

- When 802.1x authentication is enabled on a port, you cannot configure a port VLAN that is equal to a voice VLAN.
- The 802.1x authentication with VLAN assignment feature is not supported on trunk ports, dynamic ports, or with dynamic-access port assignment through a VMPS.
- You can configure 802.1x authentication on a private-VLAN port, but do not configure IEEE 802.1x authentication with port security, a voice VLAN, a guest VLAN, a restricted VLAN, or a per-user ACL on private-VLAN ports.
- You can configure any VLAN except an RSPAN VLAN, private VLAN, or a voice VLAN as an 802.1x guest VLAN. The guest VLAN feature is not supported on internal VLANs (routed ports) or trunk ports; it is supported only on access ports.
- After you configure a guest VLAN for an 802.1x port to which a DHCP client is connected, you might need to get a host IP address from a DHCP server. You can change the settings for restarting the 802.1x authentication process on the switch before the DHCP process on the client times out and tries to get a host IP address from the DHCP server. Decrease the settings for the 802.1x authentication process (authentication timer inactivity or **dot1x timeout quiet-period** and authentication timer reauthentication or **dot1x timeout tx-period**). The amount to decrease the settings depends on the connected 802.1x client type.
- When configuring the inaccessible authentication bypass feature, follow these guidelines:
 - The feature is supported on 802.1x port in single-host mode and multihosts mode.
 - If the client is running Windows XP and the port to which the client is connected is in the critical-authentication state, Windows XP might report that the interface is not authenticated.
 - If the Windows XP client is configured for DHCP and has an IP address from the DHCP server, receiving an EAP-Success message on a critical port might not re-initiate the DHCP configuration process.
 - You can configure the inaccessible authentication bypass feature and the restricted VLAN on an 802.1x port. If the switch tries to re-authenticate a critical port in a restricted VLAN and all the RADIUS servers are unavailable, switch changes the port state to the critical authentication state and remains in the restricted VLAN.
 - You can configure the inaccessible bypass feature and port security on the same switch port.
- You can configure any VLAN except an RSPAN VLAN or a voice VLAN as an 802.1x restricted VLAN. The restricted VLAN feature is not supported on internal VLANs (routed ports) or trunk ports; it is supported only on access ports.

MAC Authentication Bypass

These are the MAC authentication bypass configuration guidelines:

- Unless otherwise stated, the MAC authentication bypass guidelines are the same as the 802.1x authentication guidelines. For more information, see the [“802.1x Authentication” section on page 11-36](#).
- If you disable MAC authentication bypass from a port after the port has been authorized with its MAC address, the port state is not affected.

- If the port is in the unauthorized state and the client MAC address is not the authentication-server database, the port remains in the unauthorized state. However, if the client MAC address is added to the database, the switch can use MAC authentication bypass to re-authorize the port.
- If the port is in the authorized state, the port remains in this state until re-authorization occurs.

Maximum Number of Allowed Devices Per Port

This is the maximum number of devices allowed on an 802.1x-enabled port:

- In single-host mode, only one device is allowed on the access VLAN. If the port is also configured with a voice VLAN, an unlimited number of Cisco IP phones can send and receive traffic through the voice VLAN.
- In multidomain authentication (MDA) mode, one device is allowed for the access VLAN, and one IP phone is allowed for the voice VLAN.
- In multihost mode, only one 802.1x supplicant is allowed on the port, but an unlimited number of non-802.1x hosts are allowed on the access VLAN. An unlimited number of devices are allowed on the voice VLAN.

Configuring 802.1x Readiness Check

The 802.1x readiness check monitors 802.1x activity on all the switch ports and displays information about the devices connected to the ports that support 802.1x. You can use this feature to determine if the devices connected to the switch ports are 802.1x-capable.

The 802.1x readiness check is allowed on all ports that can be configured for 802.1x. The readiness check is not available on a port that is configured as **dot1x force-unauthorized**.

Follow these guidelines to enable the readiness check on the switch:

- The readiness check is typically used before 802.1x is enabled on the switch.
- If you use the **dot1x test eapol-capable** privileged EXEC command without specifying an interface, all the ports on the switch stack are tested.
- When you configure the **dot1x test eapol-capable** command on an 802.1x-enabled port, and the link comes up, the port queries the connected client about its 802.1x capability. When the client responds with a notification packet, it is 802.1x-capable. A syslog message is generated if the client responds within the timeout period. If the client does not respond to the query, the client is not 802.1x-capable. No syslog message is generated.
- The readiness check can be sent on a port that handles multiple hosts (for example, a PC that is connected to an IP phone). A syslog message is generated for each of the clients that respond to the readiness check within the timer period.

Beginning in privileged EXEC mode, follow these steps to enable the 802.1x readiness check on the switch:

	Command	Purpose
Step 1	dot1x test eapol-capable [interface interface-id]	Enable the 802.1x readiness check on the switch. (Optional) For <i>interface-id</i> specify the port on which to check for IEEE 802.1x readiness. Note If you omit the optional interface keyword, all interfaces on the switch are tested.
Step 1	configure terminal	(Optional) Enter global configuration mode.
Step 2	dot1x test timeout <i>timeout</i>	(Optional) Configure the timeout used to wait for EAPOL response. The range is from 1 to 65535 seconds. The default is 10 seconds.
Step 3	end	(Optional) Return to privileged EXEC mode.
Step 4	show running-config	(Optional) Verify your modified timeout values.

This example shows how to enable a readiness check on a switch to query a port. It also shows the response received from the queried port verifying that the device connected to it is 802.1x-capable:

```
switch# dot1x test eapol-capable interface gigabitethernet1/0/13
```

```
DOT1X_PORT_EAPOL_CAPABLE:DOT1X: MAC 00-01-02-4b-f1-a3 on gigabitethernet1/0/13 is EAPOL capable
```

Configuring Voice Aware 802.1x Security

You use the voice aware 802.1x security feature on the switch to disable only the VLAN on which a security violation occurs, whether it is a data or voice VLAN. You can use this feature in IP phone deployments where a PC is connected to the IP phone. A security violation found on the data VLAN results in the shutdown of only the data VLAN. The traffic on the voice VLAN flows through the switch without interruption.

Follow these guidelines to configure voice aware 802.1x voice security on the switch:

- You enable voice aware 802.1x security by entering the **reducible detect cause security-violation shutdown vlan** global configuration command. You disable voice aware 802.1x security by entering the **no** version of this command. This command applies to all 802.1x-configured ports in the switch.



Note

If you do not include the **shutdown vlan** keywords, the entire port is shut down when it enters the error-disabled state.

- If you use the **errdisable recovery cause security-violation** global configuration command to configure error-disabled recovery, the port is automatically re-enabled. If error-disabled recovery is not configured for the port, you re-enable it by using the **shutdown** and **no-shutdown** interface configuration commands.
- You can re-enable individual VLANs by using the **clear errdisable interface interface-id vlan [vlan-list]** privileged EXEC command. If you do not specify a range, all VLANs on the port are enabled.

Beginning in privileged EXEC mode, follow these steps to enable voice aware 802.1x security:

	Command	Purpose
Step 1	configure terminal	Enter global configuration mode.
Step 2	errdisable detect cause security-violation shutdown vlan	Shut down any VLAN on which a security violation error occurs. Note If the shutdown vlan keywords are not included, the entire port enters the error-disabled state and shuts down.
Step 3	errdisable recovery cause security-violation	(Optional) Enable automatic per-VLAN error recovery.
Step 4	clear errdisable interface <i>interface-id</i> vlan [<i>vlan-list</i>]	(Optional) Reenable individual VLANs that have been error disabled. <ul style="list-style-type: none"> For <i>interface-id</i> specify the port on which to reenable individual VLANs. (Optional) For <i>vlan-list</i> specify a list of VLANs to be re-enabled. If <i>vlan-list</i> is not specified, all VLANs are re-enabled.
Step 5	shutdown no-shutdown	(Optional) Re-enable an error-disabled VLAN, and clear all error-disable indications.
Step 6	end	Return to privileged EXEC mode.
Step 7	show errdisable detect	Verify your entries.
Step 8	copy running-config startup-config	(Optional) Save your entries in the configuration file.

This example shows how to configure the switch to shut down any VLAN on which a security violation error occurs:

```
Switch(config)# errdisable detect cause security-violation shutdown vlan
```

This example shows how to re-enable all VLANs that were error disabled on port Gi4/0/2.

```
Switch# clear errdisable interface GigabitEthernet4/0/2 vlan
```

You can verify your settings by entering the **show errdisable detect** privileged EXEC command.

Configuring 802.1x Violation Modes

You can configure an 802.1x port so that it shuts down, generates a syslog error, or discards packets from a new device when:

- a device connects to an 802.1x-enable port
- the maximum number of allowed about devices have been authenticated on the port

Beginning in privileged EXEC mode, follow these steps to configure the security violation actions on the switch:

	Command	Purpose
Step 1	configure terminal	Enter global configuration mode.
Step 2	aaa new-model	Enable AAA.

	Command	Purpose
Step 3	aaa authentication dot1x {default} <i>method1</i>	Create an 802.1x authentication method list. To create a default list that is used when a named list is <i>not</i> specified in the authentication command, use the default keyword followed by the method that is to be used in default situations. The default method list is automatically applied to all ports. For <i>method1</i> , enter the group radius keywords to use the list of all RADIUS servers for authentication. Note Though other keywords are visible in the command-line help string, only the group radius keywords are supported.
Step 4	interface <i>interface-id</i>	Specify the port connected to the client that is to be enabled for IEEE 802.1x authentication, and enter interface configuration mode.
Step 5	switchport mode access	Set the port to access mode.
Step 6	authentication violation shutdown restrict protect or dot1x violation-mode {shutdown restrict protect}	Configure the violation mode. The keywords have these meanings: <ul style="list-style-type: none"> • shutdown—Error disable the port. • restrict—Generate a syslog error. • protect—Drop packets from any new device that sends traffic to the port.
Step 7	end	Return to privileged EXEC mode.
Step 8	show authentication or show dot1x	Verify your entries.
Step 9	copy running-config startup-config	(Optional) Save your entries in the configuration file.

Configuring 802.1x Authentication

To configure 802.1x port-based authentication, you must enable authentication, authorization, and accounting (AAA) and specify the authentication method list. A method list describes the sequence and authentication method to be queried to authenticate a user.

To allow per-user ACLs or VLAN assignment, you must enable AAA authorization to configure the switch for all network-related service requests.

This is the 802.1x AAA process:

-
- Step 1** A user connects to a port on the switch.
 - Step 2** Authentication is performed.
 - Step 3** VLAN assignment is enabled, as appropriate, based on the RADIUS server configuration.
 - Step 4** The switch sends a start message to an accounting server.
 - Step 5** Re-authentication is performed, as necessary.
 - Step 6** The switch sends an interim accounting update to the accounting server that is based on the result of re-authentication.
 - Step 7** The user disconnects from the port.

Step 8 The switch sends a stop message to the accounting server.

Beginning in privileged EXEC mode, follow these steps to configure 802.1x port-based authentication:

	Command	Purpose
Step 1	configure terminal	Enter global configuration mode.
Step 2	aaa new-model	Enable AAA.
Step 3	aaa authentication dot1x {default} method1	Create an 802.1x authentication method list. To create a default list that is used when a named list is <i>not</i> specified in the authentication command, use the default keyword followed by the method that is to be used in default situations. The default method list is automatically applied to all ports. For <i>method1</i> , enter the group radius keywords to use the list of all RADIUS servers for authentication. Note Though other keywords are visible in the command-line help string, only the group radius keywords are supported.
Step 4	dot1x system-auth-control	Enable 802.1x authentication globally on the switch.
Step 5	aaa authorization network {default} group radius	(Optional) Configure the switch to use user-RADIUS authorization for all network-related service requests, such as per-user ACLs or VLAN assignment. Note For per-user ACLs, single-host mode must be configured. This setting is the default.
Step 6	radius-server host ip-address	(Optional) Specify the IP address of the RADIUS server.
Step 7	radius-server key string	(Optional) Specify the authentication and encryption key used between the switch and the RADIUS daemon running on the RADIUS server.
Step 8	interface interface-id	Specify the port connected to the client that is to be enabled for IEEE 802.1x authentication, and enter interface configuration mode.
Step 9	switchport mode access	(Optional) Set the port to access mode only if you configured the RADIUS server in Step 6 and Step 7.
Step 10	dot1x port-control auto	Enable 802.1x authentication on the port. For feature interaction information, see the “802.1x Authentication Configuration Guidelines” section on page 11-36 .
Step 11	end	Return to privileged EXEC mode.
Step 12	show dot1x	Verify your entries.
Step 13	copy running-config startup-config	(Optional) Save your entries in the configuration file.

Configuring the Switch-to-RADIUS-Server Communication

RADIUS security servers are identified by their hostname or IP address, hostname and specific UDP port numbers, or IP address and specific UDP port numbers. The combination of the IP address and UDP port number creates a unique identifier, which enables RADIUS requests to be sent to multiple UDP ports on

a server at the same IP address. If two different host entries on the same RADIUS server are configured for the same service—for example, authentication—the second host entry configured acts as the fail-over backup to the first one. The RADIUS host entries are tried in the order that they were configured.

Beginning in privileged EXEC mode, follow these steps to configure the RADIUS server parameters on the switch. This procedure is required.

	Command	Purpose
Step 1	configure terminal	Enter global configuration mode.
Step 2	radius-server host { <i>hostname</i> <i>ip-address</i> } auth-port <i>port-number</i> key <i>string</i>	<p>Configure the RADIUS server parameters.</p> <p>For <i>hostname</i> <i>ip-address</i>, specify the hostname or IP address of the remote RADIUS server.</p> <p>For auth-port <i>port-number</i>, specify the UDP destination port for authentication requests. The default is 1812. The range is 0 to 65536.</p> <p>For key <i>string</i>, specify the authentication and encryption key used between the switch and the RADIUS daemon running on the RADIUS server. The key is a text string that must match the encryption key used on the RADIUS server.</p> <p>Note Always configure the key as the last item in the radius-server host command syntax because leading spaces are ignored, but spaces within and at the end of the key are used. If you use spaces in the key, do not enclose the key in quotation marks unless the quotation marks are part of the key. This key must match the encryption used on the RADIUS daemon.</p> <p>If you want to use multiple RADIUS servers, re-enter this command.</p>
Step 3	end	Return to privileged EXEC mode.
Step 4	show running-config	Verify your entries.
Step 5	copy running-config startup-config	(Optional) Save your entries in the configuration file.

To delete the specified RADIUS server, use the **no radius-server host** {*hostname* | *ip-address*} global configuration command.

This example shows how to specify the server with IP address 172.20.39.46 as the RADIUS server, to use port 1612 as the authorization port, and to set the encryption key to *rad123*, matching the key on the RADIUS server:

```
Switch(config)# radius-server host 172.120.39.46 auth-port 1612 key rad123
```

You can globally configure the timeout, retransmission, and encryption key values for all RADIUS servers by using the **radius-server host** global configuration command. If you want to configure these options on a per-server basis, use the **radius-server timeout**, **radius-server retransmit**, and the **radius-server key** global configuration commands. For more information, see the [“Configuring Settings for All RADIUS Servers” section on page 10-35](#).

You also need to configure some settings on the RADIUS server. These settings include the IP address of the switch and the key string to be shared by both the server and the switch. For more information, see the RADIUS server documentation.

Configuring the Host Mode

Beginning in privileged EXEC mode, follow these steps to allow multiple hosts (clients) on an IEEE 802.1x-authorized port that has the **dot1x port-control** interface configuration command set to **auto**. Use the **multi-domain** keyword to configure and enable multidomain authentication (MDA), which allows both a host and a voice device, such as an IP phone (Cisco or non-Cisco), on the same switch port. This procedure is optional.

	Command	Purpose
Step 1	configure terminal	Enter global configuration mode.
Step 2	interface <i>interface-id</i>	Specify the port to which multiple hosts are indirectly attached, and enter interface configuration mode.
Step 3	authentication host-mode [multi-auth multi-domain multi-host single-host] or dot1x host-mode { multi-host multi-domain }	<p>Allow multiple hosts (clients) on an 802.1x-authorized port.</p> <p>The keywords have these meanings:</p> <ul style="list-style-type: none"> multi-auth—Allow one client on the voice VLAN and multiple authenticated clients on the data VLAN. <p>Note The multi-auth keyword is only available with the authentication host-mode command.</p> <ul style="list-style-type: none"> multi-host—Allow multiple hosts on an 802.1x-authorized port after a single host has been authenticated. multi-domain—Allow both a host and a voice device, such as an IP phone (Cisco or non-Cisco), to be authenticated on an IEEE 802.1x-authorized port. <p>Note You must configure the voice VLAN for the IP phone when the host mode is set to multi-domain. For more information, see Chapter 17, “Configuring Voice VLAN.”</p> <p>Make sure that the dot1x port-control interface configuration command set is set to auto for the specified interface.</p>
Step 4	end	Return to privileged EXEC mode.
Step 5	show authentication interface <i>interface-id</i> or show dot1x interface <i>interface-id</i>	Verify your entries.
Step 6	copy running-config startup-config	(Optional) Save your entries in the configuration file.

To disable multiple hosts on the port, use the **no authentication host-mode** or the **no dot1x host-mode multi-host** interface configuration command.

This example shows how to enable 802.1x authentication and to allow multiple hosts:

```
Switch(config)# interface gigabitethernet2/0/1
Switch(config-if)# dot1x port-control auto
Switch(config-if)# dot1x host-mode multi-host
```

This example shows how to enable MDA and to allow both a host and a voice device on the port:

```
Switch(config)# interface gigabitethernet3/0/1
```

```
Switch(config-if)# dot1x port-control auto
Switch(config-if)# dot1x host-mode multi-domain
Switch(config-if)# switchport voice vlan 101
Switch(config-if)# end
```

Configuring Periodic Re-Authentication

You can enable periodic 802.1x client re-authentication and specify how often it occurs. If you do not specify a time period before enabling re-authentication, the number of seconds between attempts is 3600.

Beginning in privileged EXEC mode, follow these steps to enable periodic re-authentication of the client and to configure the number of seconds between re-authentication attempts. This procedure is optional.

	Command	Purpose
Step 1	configure terminal	Enter global configuration mode.
Step 2	interface <i>interface-id</i>	Specify the port to be configured, and enter interface configuration mode.
Step 3	authentication periodic or dot1x reauthentication	Enable periodic re-authentication of the client, which is disabled by default.
Step 4	authentication timer {[inactivity reauthenticate] [server <i>am</i>]} { restart <i>value</i> }} or dot1x timeout reauth-period { <i>seconds</i> server }	<p>Set the number of seconds between re-authentication attempts.</p> <p>The authentication timer keywords have these meanings:</p> <ul style="list-style-type: none"> inactivity—Interval in seconds after which if there is no activity from the client then it is unauthorized reauthenticate—Time in seconds after which an automatic re-authentication attempt is be initiated server <i>am</i>—Interval in seconds after which an attempt is made to authenticate an unauthorized port restart <i>value</i>—Interval in seconds after which an attempt is made to authenticate an unauthorized port <p>The dot1x timeout reauth-period keywords have these meanings:</p> <ul style="list-style-type: none"> <i>seconds</i>—Sets the number of seconds from 1 to 65535; the default is 3600 seconds. server—Sets the number of seconds based on the value of the Session-Timeout RADIUS attribute (Attribute[27]) and the Termination-Action RADIUS attribute (Attribute [29]). <p>This command affects the behavior of the switch only if periodic re-authentication is enabled.</p>
Step 5	end	Return to privileged EXEC mode.
Step 6	show authentication <i>interface-id</i> or show dot1x interface <i>interface-id</i>	Verify your entries.
Step 7	copy running-config startup-config	(Optional) Save your entries in the configuration file.

To disable periodic re-authentication, use the **no authentication periodic** or the **no dot1x reauthentication** interface configuration command. To return to the default number of seconds between re-authentication attempts, use the **no authentication timer** or the **no dot1x timeout reauth-period** interface configuration command.

This example shows how to enable periodic re-authentication and set the number of seconds between re-authentication attempts to 4000:

```
Switch(config-if)# dot1x reauthentication
Switch(config-if)# dot1x timeout reauth-period 4000
```

Manually Re-Authenticating a Client Connected to a Port

You can manually re-authenticate the client connected to a specific port at any time by entering the **dot1x re-authenticate interface interface-id** privileged EXEC command. This step is optional. If you want to enable or disable periodic re-authentication, see the “[Configuring Periodic Re-Authentication](#)” section on page 11-46.

This example shows how to manually re-authenticate the client connected to a port:

```
Switch# dot1x re-authenticate interface gigabitethernet2/0/1
```

Changing the Quiet Period

When the switch cannot authenticate the client, the switch remains idle for a set period of time and then tries again. The **dot1x timeout quiet-period** interface configuration command controls the idle period. A failed authentication of the client might occur because the client provided an invalid password. You can provide a faster response time to the user by entering a number smaller than the default.

Beginning in privileged EXEC mode, follow these steps to change the quiet period. This procedure is optional.

	Command	Purpose
Step 1	configure terminal	Enter global configuration mode.
Step 2	interface interface-id	Specify the port to be configured, and enter interface configuration mode.
Step 3	dot1x timeout quiet-period seconds	Set the number of seconds that the switch remains in the quiet state following a failed authentication exchange with the client. The range is 1 to 65535 seconds; the default is 60.
Step 4	end	Return to privileged EXEC mode.
Step 5	show authentication interface-id or show dot1x interface interface-id	Verify your entries.
Step 6	copy running-config startup-config	(Optional) Save your entries in the configuration file.

To return to the default quiet time, use the **no dot1x timeout quiet-period** interface configuration command.

This example shows how to set the quiet time on the switch to 30 seconds:

```
Switch(config-if)# dot1x timeout quiet-period 30
```

Changing the Switch-to-Client Retransmission Time

The client responds to the EAP-request/identity frame from the switch with an EAP-response/identity frame. If the switch does not receive this response, it waits a set period of time (known as the retransmission time) and then resends the frame.



Note You should change the default value of this command only to adjust for unusual circumstances such as unreliable links or specific behavioral problems with certain clients and authentication servers.

Beginning in privileged EXEC mode, follow these steps to change the amount of time that the switch waits for client notification. This procedure is optional.

	Command	Purpose
Step 1	configure terminal	Enter global configuration mode.
Step 2	interface <i>interface-id</i>	Specify the port to be configured, and enter interface configuration mode.
Step 3	dot1x timeout tx-period <i>seconds</i>	Set the number of seconds that the switch waits for a response to an EAP-request/identity frame from the client before resending the request. The range is 1 to 65535 seconds; the default is 5.
Step 4	end	Return to privileged EXEC mode.
Step 5	show authentication <i>interface-id</i> or show dot1xinterface <i>interface-id</i>	Verify your entries.
Step 6	copy running-config startup-config	(Optional) Save your entries in the configuration file.

To return to the default retransmission time, use the **no dot1x timeout tx-period** interface configuration command.

This example shows how to set 60 as the number of seconds that the switch waits for a response to an EAP-request/identity frame from the client before resending the request:

```
Switch(config-if)# dot1x timeout tx-period 60
```

Setting the Switch-to-Client Frame-Retransmission Number

In addition to changing the switch-to-client retransmission time, you can change the number of times that the switch sends an EAP-request/identity frame (assuming no response is received) to the client before restarting the authentication process.



Note You should change the default value of this command only to adjust for unusual circumstances such as unreliable links or specific behavioral problems with certain clients and authentication servers.

Beginning in privileged EXEC mode, follow these steps to set the switch-to-client frame-retransmission number. This procedure is optional.

	Command	Purpose
Step 1	configure terminal	Enter global configuration mode.
Step 2	interface <i>interface-id</i>	Specify the port to be configured, and enter interface configuration mode.
Step 3	dot1x max-reauth-req <i>count</i>	Set the number of times that the switch sends an EAP-request/identity frame to the client before restarting the authentication process. The range is 1 to 10; the default is 2.
Step 4	end	Return to privileged EXEC mode.
Step 5	show authentication <i>interface-id</i> or show dot1x interface <i>interface-id</i>	Verify your entries.
Step 6	copy running-config startup-config	(Optional) Save your entries in the configuration file.

To return to the default retransmission number, use the **no dot1x max-req** interface configuration command.

This example shows how to set 5 as the number of times that the switch sends an EAP-request/identity request before restarting the authentication process:

```
Switch(config-if)# dot1x max-req 5
```

Setting the Re-Authentication Number

You can also change the number of times that the switch restarts the authentication process before the port changes to the unauthorized state.



Note

You should change the default value of this command only to adjust for unusual circumstances such as unreliable links or specific behavioral problems with certain clients and authentication servers.

Beginning in privileged EXEC mode, follow these steps to set the re-authentication number. This procedure is optional.

	Command	Purpose
Step 1	configure terminal	Enter global configuration mode.
Step 2	interface <i>interface-id</i>	Specify the port to be configured, and enter interface configuration mode.
Step 3	dot1x max-reauth-req <i>count</i>	Set the number of times that the switch restarts the authentication process before the port changes to the unauthorized state. The range is 0 to 10; the default is 2.
Step 4	end	Return to privileged EXEC mode.

	Command	Purpose
Step 5	show authentication <i>interface-id</i> or show dot1x interface <i>interface-id</i>	Verify your entries.
Step 6	copy running-config startup-config	(Optional) Save your entries in the configuration file.

To return to the default re-authentication number, use the **no dot1x max-reauth-req** interface configuration command.

This example shows how to set 4 as the number of times that the switch restarts the authentication process before the port changes to the unauthorized state:

```
Switch(config-if)# dot1x max-reauth-req 4
```

Enabling MAC Move

MAC move allows an authenticated host to move from one port on the switch to another.

Beginning in privileged EXEC mode, follow these steps to globally enable MAC move on the switch. This procedure is optional.

Command	Purpose
configure terminal	Enter global configuration mode.
authentication mac-move permit	Enable
end	Return to privileged EXEC mode.
show run	Verify your entries.
copy running-config startup-config	(Optional) Save your entries in the configuration file.

This example shows how to globally enable MAC move on a switch:

```
Switch(config)# authentication mac-move permit
```

Configuring 802.1x Accounting

Enabling AAA system accounting with 802.1x accounting allows system reload events to be sent to the accounting RADIUS server for logging. The server can then infer that all active 802.1x sessions are closed.

Because RADIUS uses the unreliable UDP transport protocol, accounting messages might be lost due to poor network conditions. If the switch does not receive the accounting response message from the RADIUS server after a configurable number of retransmissions of an accounting request, this system message appears:

```
Accounting message %s for session %s failed to receive Accounting Response.
```

When the stop message is not sent successfully, this message appears:

```
00:09:55: %RADIUS-4-RADIUS_DEAD: RADIUS server 172.20.246.201:1645,1646 is not responding.
```

**Note**

You must configure the RADIUS server to perform accounting tasks, such as logging start, stop, and interim-update messages and time stamps. To turn on these functions, enable logging of “Update/Watchdog packets from this AAA client” in your RADIUS server Network Configuration tab. Next, enable “CVS RADIUS Accounting” in your RADIUS server System Configuration tab.

Beginning in privileged EXEC mode, follow these steps to configure 802.1x accounting after AAA is enabled on your switch. This procedure is optional.

	Command	Purpose
Step 1	configure terminal	Enter global configuration mode.
Step 2	interface <i>interface-id</i>	Specify the port to be configured, and enter interface configuration mode.
Step 3	aaa accounting dot1x default start-stop group radius	Enable 802.1x accounting using the list of all RADIUS servers.
Step 4	aaa accounting system default start-stop group radius	(Optional) Enables system accounting (using the list of all RADIUS servers) and generates system accounting reload event messages when the switch reloads.
Step 5	end	Return to privileged EXEC mode.
Step 6	show running-config	Verify your entries.
Step 7	copy running-config startup-config	(Optional) Saves your entries in the configuration file.

Use the **show radius statistics** privileged EXEC command to display the number of RADIUS messages that do not receive the accounting response message.

This example shows how to configure 802.1x accounting. The first command configures the RADIUS server, specifying 1813 as the UDP port for accounting:

```
Switch(config)# radius-server host 172.120.39.46 auth-port 1812 acct-port 1813 key rad123
Switch(config)# aaa accounting dot1x default start-stop group radius
Switch(config)# aaa accounting system default start-stop group radius
```

Configuring a Guest VLAN

When you configure a guest VLAN, clients that are not 802.1x-capable are put into the guest VLAN when the server does not receive a response to its EAP request/identity frame. Clients that are 802.1x-capable but that fail authentication are not granted network access. The switch supports guest VLANs in single-host or multiple-hosts mode.

Beginning in privileged EXEC mode, follow these steps to configure a guest VLAN. This procedure is optional.

	Command	Purpose
Step 1	configure terminal	Enter global configuration mode.
Step 2	interface <i>interface-id</i>	Specify the port to be configured, and enter interface configuration mode. For the supported port types, see the “802.1x Authentication Configuration Guidelines” section on page 11-36.

	Command	Purpose
Step 3	switchport mode access or switchport mode private-vlan host	Set the port to access mode, or Configure the Layer 2 port as a private-VLAN host port.
Step 4	dot1x port-control auto	Enable 802.1x authentication on the port.
Step 5	dot1x guest-vlan <i>vlan-id</i>	Specify an active VLAN as an 802.1x guest VLAN. The range is 1 to 4094. You can configure any active VLAN except an internal VLAN (routed port), an RSPAN VLAN, a primary private VLAN, or a voice VLAN as an 802.1x guest VLAN.
Step 6	end	Return to privileged EXEC mode.
Step 7	show authentication <i>interface-id</i> or show dot1x interface <i>interface-id</i>	Verify your entries.
Step 8	copy running-config startup-config	(Optional) Save your entries in the configuration file.

To disable and remove the guest VLAN, use the **no dot1x guest-vlan** interface configuration command. The port returns to the unauthorized state.

This example shows how to enable VLAN 2 as an 802.1x guest VLAN:

```
Switch(config)# interface gigabitEthernet2/0/2
Switch(config-if)# dot1x guest-vlan 2
```

This example shows how to set 3 as the quiet time on the switch, to set 15 as the number of seconds that the switch waits for a response to an EAP-request/identity frame from the client before re-sending the request, and to enable VLAN 2 as an 802.1x guest VLAN when an 802.1x port is connected to a DHCP client:

```
Switch(config-if)# dot1x timeout quiet-period 3
Switch(config-if)# dot1x timeout tx-period 15
Switch(config-if)# dot1x guest-vlan 2
```

Configuring a Restricted VLAN

When you configure a restricted VLAN on a switch stack or a switch, clients that are IEEE 802.1x-compliant are moved into the restricted VLAN when the authentication server does not receive a valid username and password. The switch supports restricted VLANs only in single-host mode.

Beginning in privileged EXEC mode, follow these steps to configure a restricted VLAN. This procedure is optional.

	Command	Purpose
Step 1	configure terminal	Enter global configuration mode.
Step 2	interface <i>interface-id</i>	Specify the port to be configured, and enter interface configuration mode. For the supported port types, see the “802.1x Authentication Configuration Guidelines” section on page 11-36.

	Command	Purpose
Step 3	switchport mode access or switchport mode private-vlan host	Set the port to access mode, or Configure the Layer 2 port as a private-VLAN host port.
Step 4	authentication port-control auto or dot1x port-control auto	Enable 802.1x authentication on the port.
Step 5	dot1x auth-fail vlan <i>vlan-id</i>	Specify an active VLAN as an 802.1x restricted VLAN. The range is 1 to 4094. You can configure any active VLAN except an internal VLAN (routed port), an RSPAN VLAN, a primary private VLAN, or a voice VLAN as an 802.1x restricted VLAN.
Step 6	end	Return to privileged EXEC mode.
Step 7	show authentication <i>interface-id</i> or show dot1x interface <i>interface-id</i>	(Optional) Verify your entries.
Step 8	copy running-config startup-config	(Optional) Save your entries in the configuration file.

To disable and remove the restricted VLAN, use the **no dot1x auth-fail vlan** interface configuration command. The port returns to the unauthorized state.

This example shows how to enable *VLAN 2* as an 802.1x restricted VLAN:

```
Switch(config)# interface gigabitethernet2/0/2
Switch(config-if)# dot1x auth-fail vlan 2
```

You can configure the maximum number of authentication attempts allowed before a user is assigned to the restricted VLAN by using the **dot1x auth-fail max-attempts** interface configuration command. The range of allowable authentication attempts is 1 to 3. The default is 3 attempts.

Beginning in privileged EXEC mode, follow these steps to configure the maximum number of allowed authentication attempts. This procedure is optional.

	Command	Purpose
Step 1	configure terminal	Enter global configuration mode.
Step 2	interface <i>interface-id</i>	Specify the port to be configured, and enter interface configuration mode. For the supported port types, see the “802.1x Authentication Configuration Guidelines” section on page 11-36.
Step 3	switchport mode access or switchport mode private-vlan host	Set the port to access mode, or Configure the Layer 2 port as a private-VLAN host port.
Step 4	authentication port-control auto or dot1x port-control auto	Enable 802.1x authentication on the port.

	Command	Purpose
Step 5	dot1x auth-fail vlan <i>vlan-id</i>	Specify an active VLAN as an 802.1x restricted VLAN. The range is 1 to 4094. You can configure any active VLAN except an internal VLAN (routed port), an RSPAN VLAN, a primary private VLAN, or a voice VLAN as an 802.1x restricted VLAN.
Step 6	dot1x auth-fail max-attempts <i>max attempts</i>	Specify a number of authentication attempts to allow before a port moves to the restricted VLAN. The range is 1 to 3, and the default is 3.
Step 7	end	Return to privileged EXEC mode.
Step 8	show authentication <i>interface-id</i> or show dot1x interface <i>interface-id</i>	(Optional) Verify your entries.
Step 9	copy running-config startup-config	(Optional) Save your entries in the configuration file.

To return to the default value, use the **no dot1x auth-fail max-attempts** interface configuration command.

This example shows how to set 2 as the number of authentication attempts allowed before the port moves to the restricted VLAN:

```
Switch(config-if)# dot1x auth-fail max-attempts 2
```

Configuring the Inaccessible Authentication Bypass Feature

You can configure the inaccessible bypass feature, also referred to as critical authentication or the AAA fail policy.

Beginning in privileged EXEC mode, follow these steps to configure the port as a critical port and enable the inaccessible authentication bypass feature. This procedure is optional.

	Command	Purpose
Step 1	configure terminal	Enter global configuration mode.
Step 2	radius-server dead-criteria time <i>time</i> tries <i>tries</i>	(Optional) Set the conditions that are used to decide when a RADIUS server is considered unavailable or <i>dead</i> . The range for <i>time</i> is from 1 to 120 seconds. The switch dynamically determines the default <i>seconds</i> value that is 10 to 60 seconds. The range for <i>tries</i> is from 1 to 100. The switch dynamically determines the default <i>tries</i> parameter that is 10 to 100.
Step 3	radius-server deadtime <i>minutes</i>	(Optional) Set the number of minutes that a RADIUS server is not sent requests. The range is from 0 to 1440 minutes (24 hours). The default is 0 minutes.

Command	Purpose
Step 4 radius-server host <i>ip-address</i> [acct-port <i>udp-port</i>] [auth-port <i>udp-port</i>] [test username <i>name</i> [idle-time <i>time</i>] [ignore-acct-port] [ignore-auth-port] [key <i>string</i>]	<p>(Optional) Configure the RADIUS server parameters by using these keywords:</p> <ul style="list-style-type: none"> • acct-port <i>udp-port</i>—Specify the UDP port for the RADIUS accounting server. The range for the UDP port number is from 0 to 65536. The default is 1646. • auth-port <i>udp-port</i>—Specify the UDP port for the RADIUS authentication server. The range for the UDP port number is from 0 to 65536. The default is 1645. <p>Note You should configure the UDP port for the RADIUS accounting server and the UDP port for the RADIUS authentication server to nondefault values.</p> <ul style="list-style-type: none"> • test username <i>name</i>—Enable automated testing of the RADIUS server status, and specify the username to be used. • idle-time <i>time</i>—Set the interval of time in minutes after which the switch sends test packets to the server. The range is from 1 to 35791 minutes. The default is 60 minutes (1 hour). • ignore-acct-port—Disable testing on the RADIUS-server accounting port. • ignore-auth-port—Disable testing on the RADIUS-server authentication port. • For key <i>string</i>, specify the authentication and encryption key used between the switch and the RADIUS daemon running on the RADIUS server. The key is a text string that must match the encryption key used on the RADIUS server. <p>Note Always configure the key as the last item in the radius-server host command syntax because leading spaces are ignored, but spaces within and at the end of the key are used. If you use spaces in the key, do not enclose the key in quotation marks unless the quotation marks are part of the key. This key must match the encryption used on the RADIUS daemon.</p> <p>You can also configure the authentication and encryption key by using the radius-server key {0 <i>string</i> 7 <i>string</i> <i>string</i>} global configuration command.</p>
Step 5 dot1x critical { eapol recovery delay <i>milliseconds</i> }	<p>(Optional) Configure the parameters for inaccessible authentication bypass:</p> <p>eapol—Specify that the switch sends an EAPOL-Success message when the switch successfully authenticates the critical port.</p> <p>recovery delay <i>milliseconds</i>—Set the recovery delay period during which the switch waits to re-initialize a critical port when a RADIUS server that was unavailable becomes available. The range is from 1 to 10000 milliseconds. The default is 1000 milliseconds (a port can be re-initialized every second).</p>
Step 6 interface <i>interface-id</i>	<p>Specify the port to be configured, and enter interface configuration mode. For the supported port types, see the “802.1x Authentication Configuration Guidelines” section on page 11-36.</p>

	Command	Purpose
Step 7	authentication event server dead action [authorize reinitialize] vlan <i>vlan-id</i>	Use these keywords to move hosts on the port if the RADIUS server is unreachable: <ul style="list-style-type: none"> • authorize—Move any new hosts trying to authenticate to the user-specified critical VLAN. • reinitialize—Move all authorized hosts on the port to the user-specified critical VLAN.
Step 8	dot1x critical [recovery action reinitialize vlan <i>vlan-id</i>]	Enable the inaccessible authentication bypass feature, and use these keywords to configure the feature: <ul style="list-style-type: none"> • recovery action reinitialize—Enable the recovery feature, and specify that the recovery action is to authenticate the port when an authentication server is available. • vlan <i>vlan-id</i>—Specify the access VLAN to which the switch can assign a critical port. The range is from 1 to 4094.
Step 9	end	Return to privileged EXEC mode.
Step 10	show authentication interface-id or show dot1x [interface interface-id]	(Optional) Verify your entries.
Step 11	copy running-config startup-config	(Optional) Save your entries in the configuration file.

To return to the RADIUS server default settings, use the **no radius-server dead-criteria**, the **no radius-server deadtime**, and the **no radius-server host** global configuration commands. To return to the default settings of inaccessible authentication bypass, use the **no dot1x critical {eapol | recovery delay}** global configuration command. To disable inaccessible authentication bypass, use the **no dot1x critical** interface configuration command.

This example shows how to configure the inaccessible authentication bypass feature:

```
Switch(config)# radius-server dead-criteria time 30 tries 20
Switch(config)# radius-server deadtime 60
Switch(config)# radius-server host 1.1.1.2 acct-port 1550 auth-port 1560 test username
user1 idle-time 30 key abc1234
Switch(config)# dot1x critical eapol
Switch(config)# dot1x critical recovery delay 2000
Switch(config)# interface gigabitethernet 1/0/1
Switch(config)# radius-server deadtime 60
Switch(config-if)# dot1x critical
Switch(config-if)# dot1x critical recovery action reinitialize
Switch(config-if)# dot1x critical vlan 20
Switch(config-if)# end
```

Configuring 802.1x Authentication with WoL

Beginning in privileged EXEC mode, follow these steps to enable 802.1x authentication with WoL. This procedure is optional.

	Command	Purpose
Step 1	configure terminal	Enter global configuration mode.
Step 2	interface <i>interface-id</i>	Specify the port to be configured, and enter interface configuration mode. For the supported port types, see the “ 802.1x Authentication Configuration Guidelines ” section on page 11-36.
Step 3	dot1x control-direction { both in }	Enable 802.1x authentication with WoL on the port, and use these keywords to configure the port as bidirectional or unidirectional. <ul style="list-style-type: none"> both—Sets the port as bidirectional. The port cannot receive packets from or send packets to the host. By default, the port is bidirectional. in—Sets the port as unidirectional. The port can send packets to the host but cannot receive packets from the host.
Step 4	end	Return to privileged EXEC mode.
Step 5	show authentication <i>interface-id</i> or show dot1x interface <i>interface-id</i>	Verify your entries.
Step 6	copy running-config startup-config	(Optional) Save your entries in the configuration file.

To disable 802.1x authentication with WoL, use the **no dot1x control-direction** interface configuration command.

This example shows how to enable 802.1x authentication with WoL and set the port as bidirectional:

```
Switch(config-if)# dot1x control-direction both
```

Configuring MAC Authentication Bypass

Beginning in privileged EXEC mode, follow these steps to enable MAC authentication bypass. This procedure is optional.

	Command	Purpose
Step 1	configure terminal	Enter global configuration mode.
Step 2	interface <i>interface-id</i>	Specify the port to be configured, and enter interface configuration mode. For the supported port types, see the “ 802.1x Authentication Configuration Guidelines ” section on page 11-36.
Step 3	authentication port-control auto or dot1x port-control auto	Enable 802.1x authentication on the port.

	Command	Purpose
Step 4	dot1x mac-auth-bypass [<i>eap</i>]	Enable MAC authentication bypass. (Optional) Use the eap keyword to configure the switch to use EAP for authorization.
Step 5	end	Return to privileged EXEC mode.
Step 6	show authentication <i>interface-id</i> or show dot1x interface <i>interface-id</i>	Verify your entries.
Step 7	copy running-config startup-config	(Optional) Save your entries in the configuration file.

To disable MAC authentication bypass, use the **no dot1x mac-auth-bypass** interface configuration command.

This example shows how to enable MAC authentication bypass:

```
Switch(config-if)# dot1x mac-auth-bypass
```

Configuring 802.1x User Distribution

Beginning in global configuration, follow these steps to configure a VLAN group and to map a VLAN to it:

	Command	Purpose
Step 1	vlan group <i>vlan-group-name</i> vlan-list <i>vlan-list</i>	Configure a VLAN group, and map a single VLAN or a range of VLANs to it.
Step 2	show vlan group all <i>vlan-group-name</i>	Verify the configuration.
Step 3	no vlan group <i>vlan-group-name</i> vlan-list <i>vlan-list</i>	Clear the VLAN group configuration or elements of the VLAN group configuration.

This example shows how to configure the VLAN groups, to map the VLANs to the groups, to and verify the VLAN group configurations and mapping to the specified VLANs:

```
switch(config)# vlan group eng-dept vlan-list 10

switch(config)# show vlan group group-name eng-dept
Group Name                Vlans Mapped
-----
eng-dept                   10
switch# show dot1x vlan-group all
Group Name                Vlans Mapped
-----
eng-dept                   10
hr-dept                    20
```

This example shows how to add a VLAN to an existing VLAN group and to verify that the VLAN was added:

```
switch(config)# vlan group eng-dept vlan-list 30
switch(config)# show vlan group eng-dept
Group Name                Vlans Mapped
-----
```

```
eng-dept                               10,30
```

This example shows how to remove a VLAN from a VLAN group:

```
switch# no vlan group eng-dept vlan-list 10
```

This example shows that when all the VLANs are cleared from a VLAN group, the VLAN group is cleared:

```
switch(config)# no vlan group eng-dept vlan-list 30
Vlan 30 is successfully cleared from vlan group eng-dept.
```

```
switch(config)# show vlan group group-name eng-dept
```

This example shows how to clear all the VLAN groups:

```
switch(config)# no vlan group eng-dept vlan-list all
switch(config)# show vlan-group all
```

For more information about these commands, see the *Cisco IOS Security Command Reference*.

Configuring NAC Layer 2 IEEE 802.1x Validation

You can configure NAC Layer 2 802.1x validation, which is also referred to as 802.1x authentication with a RADIUS server.

Beginning in privileged EXEC mode, follow these steps to configure NAC Layer 2 802.1x validation. The procedure is optional.

	Command	Purpose
Step 1	configure terminal	Enter global configuration mode.
Step 2	interface <i>interface-id</i>	Specify the port to be configured, and enter interface configuration mode.
Step 3	dot1x guest-vlan <i>vlan-id</i>	Specify an active VLAN as an 802.1x guest VLAN. The range is 1 to 4094. You can configure any active VLAN except an internal VLAN (routed port), an RSPAN VLAN, or a voice VLAN as an 802.1x guest VLAN.
Step 4	authentication periodic or dot1x reauthentication	Enable periodic re-authentication of the client, which is disabled by default.
Step 5	dot1x timeout reauth-period { <i>seconds</i> <i>server</i> }	Set the number of seconds between re-authentication attempts. The keywords have these meanings: <ul style="list-style-type: none"> <i>seconds</i>—Sets the number of seconds from 1 to 65535; the default is 3600 seconds. server—Sets the number of seconds based on the value of the Session-Timeout RADIUS attribute (Attribute[27]) and the Termination-Action RADIUS attribute (Attribute [29]). This command affects the behavior of the switch only if periodic re-authentication is enabled.
Step 6	end	Return to privileged EXEC mode.

	Command	Purpose
Step 7	show authentication <i>interface-id</i> or show dot1x interface <i>interface-id</i>	Verify your 802.1x authentication configuration.
Step 8	copy running-config startup-config	(Optional) Save your entries in the configuration file.

This example shows how to configure NAC Layer 2 802.1x validation:

```
Switch# configure terminal
Switch(config)# interface gigabitethernet2/0/1
Switch(config-if)# dot1x reauthentication
Switch(config-if)# dot1x timeout reauth-period server
```

Configuring an Authenticator and a Supplicant Switch with NEAT

Configuring this feature requires that one switch outside a wiring closet is configured as a supplicant and is connected to an authenticator switch.

For overview information, see the “[802.1x Supplicant and Authenticator Switches with Network Edge Access Topology \(NEAT\)](#)” section on page 11-29.



Note

The *cisco-av-pairs* must be configured as *device-traffic-class=switch* on the ACS, which sets the interface as a trunk after the supplicant is successfully authenticated.

Beginning in privileged EXEC mode, follow these steps to configure a switch as an authenticator:

	Command	Purpose
Step 1	configure terminal	Enter global configuration mode.
Step 2	cisp enable	Enable CISP.
Step 3	interface <i>interface-id</i>	Specify the port to be configured, and enter interface configuration mode.
Step 4	switchport mode access	Set the port mode to access .
Step 5	authentication port-control auto	Set the port-authentication mode to auto.
Step 6	dot1x pae authenticator	Configure the interface as a port access entity (PAE) authenticator.
Step 7	spanning-tree portfast	Enable Port Fast on an access port connected to a single workstation or server..
Step 8	end	Return to privileged EXEC mode.
Step 9	show running-config interface <i>interface-id</i>	Verify your configuration.
Step 10	copy running-config startup-config	(Optional) Save your entries in the configuration file.

This example shows how to configure a switch as an 802.1x authenticator:

```
Switch# configure terminal
Switch(config)# cisp enable
Switch(config)# interface gigabitethernet2/0/1
Switch(config-if)# switchport mode access
```

```
Switch(config-if)# authentication port-control auto
Switch(config-if)# dot1x pae authenticator
Switch(config-if)# spanning-tree portfast trunk
```

Beginning in privileged EXEC mode, follow these steps to configure a switch as a supplicant:

	Command	Purpose
Step 1	configure terminal	Enter global configuration mode.
Step 2	cisp enable	Enable CISP.
Step 3	dot1x credentials <i>profile</i>	Create 802.1x credentials profile. This must be attached to the port that is configured as supplicant.
Step 4	username <i>suppswitch</i>	Create a username.
Step 5	password <i>password</i>	Create a password for the new username.
Step 6	dot1x supplicant force-multicast	Force the switch to send <i>only</i> multicast EAPOL packets when it receives either unicast or multicast packets. This also allows NEAT to work on the supplicant switch in all host modes.
Step 7	interface <i>interface-id</i>	Specify the port to be configured, and enter interface configuration mode.
Step 8	switchport trunk encapsulation dot1q	Set the port to trunk mode.
Step 9	switchport mode trunk	Configure the interface as a VLAN trunk port.
Step 10	dot1x pae supplicant	Configure the interface as a port access entity (PAE) supplicant.
Step 11	dot1x credentials <i>profile-name</i>	Attach the 802.1x credentials profile to the interface.
Step 12	end	Return to privileged EXEC mode.
Step 13	show running-config interface <i>interface-id</i>	Verify your configuration.
Step 14	copy running-config startup-config	(Optional) Save your entries in the configuration file.

This example shows how to configure a switch as a supplicant:

```
Switch# configure terminal
Switch(config)# cisp enable
Switch(config)# dot1x credentials test
Switch(config)# username suppswitch
Switch(config)# password myswitch
Switch(config)# dot1x supplicant force-multicast
Switch(config)# interface gigabitethernet1/0/1
Switch(config-if)# switchport trunk encapsulation dot1q
Switch(config-if)# switchport mode trunk
Switch(config-if)# dot1x pae supplicant
Switch(config-if)# dot1x credentials test
Switch(config-if)# end
```

Configuring NEAT with ASP

You can also use an AutoSmart Ports user-defined macro instead of the switch VSA to configure the authenticator switch. For more information, see the [Chapter 14, “Configuring Auto Smartports Macros.”](#)

Configuring 802.1x Authentication with Downloadable ACLs and Redirect URLs

In addition to configuring 802.1x authentication on the switch, you need to configure the ACS. For more information, see the [Cisco Secure ACS configuration guides](#).



Note

You must configure a downloadable ACL on the ACS before downloading it to the switch.

After authentication on the port, you can use the **show ip access-list** privileged EXEC command to display the downloaded ACLs on the port.

Configuring Downloadable ACLs

The policies take effect after client authentication and the client IP address addition to the IP device tracking table. The switch then applies the downloadable ACL to the port.

Beginning in privileged EXEC mode:

	Command	Purpose
Step 1	configure terminal	Enter global configuration mode.
Step 2	ip device tracking	Configure the ip device tracking table.
Step 3	aaa new-model	Enables AAA.
Step 4	aaa authorization network default group radius	Sets the authorization method to local. To remove the authorization method, use the no aaa authorization network default group radius command.
Step 5	radius-server vsa send authentication	Configure the radius vsa send authentication.
Step 6	interface interface-id	Specify the port to be configured, and enter interface configuration mode.

	Command	Purpose
Step 7	ip access-group <i>acl-id</i> in	Configure the default ACL on the port in the input direction. Note The <i>acl-id</i> is an access list name or number.
Step 8	show running-config interface <i>interface-id</i>	Verify your configuration.
Step 9	copy running-config startup-config	(Optional) Save your entries in the configuration file.

Configuring a Downloadable Policy

Beginning in privileged EXEC mode:

	Command	Purpose
Step 1	configure terminal	Enter global configuration mode.
Step 2	access-list <i>access-list-number</i> deny source <i>source-wildcard</i> log	Defines the default port ACL by using a source address and wildcard. The <i>access-list-number</i> is a decimal number from 1 to 99 or 1300 to 1999. Enter deny or permit to specify whether to deny or permit access if conditions are matched. The <i>source</i> is the source address of the network or host that sends a packet, such as this: <ul style="list-style-type: none"> The 32-bit quantity in dotted-decimal format. The keyword any as an abbreviation for source and source-wildcard value of 0.0.0.0 255.255.255.255. You do not need to enter a source-wildcard value. The keyword host as an abbreviation for source and source-wildcard of source 0.0.0.0. (Optional) Applies the source-wildcard wildcard bits to the source. (Optional) Enters log to cause an informational logging message about the packet that matches the entry to be sent to the console.
Step 3	interface <i>interface-id</i>	Enter interface configuration mode.
Step 4	ip access-group <i>acl-id</i> in	Configure the default ACL on the port in the input direction. Note The <i>acl-id</i> is an access list name or number.
Step 5	exit	Returns to global configuration mode.
Step 6	aaa new-model	Enables AAA.
Step 7	aaa authorization network default group radius	Sets the authorization method to local. To remove the authorization method, use the no aaa authorization network default group radius command.
Step 8	ip device tracking	Enables the IP device tracking table. To disable the IP device tracking table, use the no ip device tracking global configuration commands.

	Command	Purpose
Step 9	ip device tracking probe count <i>count</i>	(Optional) Configures the IP device tracking table: <ul style="list-style-type: none"> • count <i>count</i>—Sets the number of times that the switch sends the ARP probe. The range is from 1 to 5. The default is 3. • interval <i>interval</i>—Sets the number of seconds that the switch waits for a response before resending the ARP probe. The range is from 30 to 300 seconds. The default is 30 seconds.
Step 10	radius-server vsa send authentication	Configures the network access server to recognize and use vendor-specific attributes. Note The downloadable ACL must be operational.
Step 11	end	Returns to privileged EXEC mode.
Step 12	show ip device tracking all	Displays information about the entries in the IP device tracking table.
Step 13	copy running-config startup-config	(Optional) Saves your entries in the configuration file.

This example shows how to configure a switch for a downloadable policy:

```
Switch# config terminal
Enter configuration commands, one per line. End with CNTL/Z.
Switch(config)# aaa new-model
Switch(config)# aaa authorization network default group radius
Switch(config)# ip device tracking
Switch(config)# ip access-list extended default_acl
Switch(config-ext-nacl)# permit ip any any
Switch(config-ext-nacl)# exit
Switch(config)# radius-server vsa send authentication
Switch(config)# int fastEthernet 2/13
Switch(config-if)# ip access-group default_acl in
Switch(config-if)# exit
```

Configuring VLAN ID-based MAC Authentication

Beginning in privileged EXEC mode, follow these steps:

	Command	Purpose
Step 1	configure terminal	Enter global configuration mode.
Step 2	mab request format attribute 32 vlan access-vlan	Enable VLAN ID-based MAC authentication.
Step 3	copy running-config startup-config	(Optional) Save your entries in the configuration file.

There is no show command to confirm the status of VLAN ID-based MAC authentication. You can use the **debug radius accounting** privileged EXEC command to confirm the RADIUS attribute 32. For more information about this command, see the *Cisco IOS Debug Command Reference, Release 12.2* at this URL:

http://www.cisco.com/en/US/docs/ios/debug/command/reference/db_q1.html#wp1123741

This example shows how to globally enable VLAN ID-based MAC authentication on a switch:

```
Switch# config terminal
Enter configuration commands, one per line. End with CNTL/Z.
Switch(config)# mab request format attribute 32 vlan access-vlan
Switch(config-if)# exit
```

Configuring Flexible Authentication Ordering

Beginning in privileged EXEC mode, follow these steps:

	Command	Purpose
Step 1	configure terminal	Enter global configuration mode.
Step 2	interface <i>interface-id</i>	Specify the port to be configured, and enter interface configuration mode.
Step 3	authentication order dot1x mab {webauth}	(Optional) Set the order of authentication methods used on a port.
Step 4	authentication priority dot1x mab {webauth}	(Optional) Add an authentication method to the port-priority list.
Step 5	show authentication	(Optional) Verify your entries.
Step 6	copy running-config startup-config	(Optional) Save your entries in the configuration file.

This example shows how to configure a port attempt 802.1x authentication first, followed by web authentication as fallback method:

```
Switch# configure terminal
Switch(config)# interface gigabitethernet 1/0/1
Switch(config)# authentication order dot1x webauth
```

Configuring Open1x

Beginning in privileged EXEC mode:

	Command	Purpose
Step 1	configure terminal	Enter global configuration mode.
Step 2	interface <i>interface-id</i>	Specify the port to be configured, and enter interface configuration mode.
Step 3	authentication control-direction {both in}	(Optional) Configure the port control as unidirectional or bidirectional.
Step 4	authentication fallback <i>name</i>	(Optional) Configure a port to use web authentication as a fallback method for clients that do not support 802.1x authentication.
Step 5	authentication host-mode [multi-auth multi-domain multi-host single-host]	(Optional) Set the authorization manager mode on a port.
Step 6	authentication open	(Optional) Enable or disable open access on a port.
Step 7	authentication order dot1x mab {webauth}	(Optional) Set the order of authentication methods used on a port.

	Command	Purpose
Step 8	authentication periodic	(Optional) Enable or disable reauthentication on a port.
Step 9	authentication port-control {auto force-authorized force-un authorized}	(Optional) Enable manual control of the port authorization state.
Step 10	show authentication	(Optional) Verify your entries.
Step 11	copy running-config startup-config	(Optional) Save your entries in the configuration file.

This example shows how to configure open 1x on a port:

```
Switch# configure terminal
Switch(config)# interface gigabitethernet 1/0/1
Switch(config)# authentication control-direction both
Switch(config)# authentication fallback profile1
Switch(config)# authentication host-mode multi-auth
Switch(config)# authentication open
Switch(config)# authentication order dot1x webauth
Switch(config)# authentication periodic
Switch(config)# authentication port-control auto
```

Configuring a Web Authentication Local Banner

Beginning in privileged EXEC mode, follow these steps to configure a local banner on a switch that has web authentication configured.

	Command	Purpose
Step 1	configure terminal	Enter global configuration mode.
Step 2	ip admission auth-proxy-banner http [<i>banner-text</i> <i>file-path</i>]	Enable the local banner. (Optional) Create a custom banner by entering <i>C banner-text C</i> , where <i>C</i> is a delimiting character or file-path indicates a file (for example, a logo or text file) that appears in the banner.
Step 3	end	Return to privileged EXEC mode.

This example shows how to configure a local banner with the custom message *My Switch*:

```
Switch(config) configure terminal
Switch(config)# aaa new-model
Switch(config)# aaa ip auth-proxy auth-proxy-banner C My Switch C
Switch(config) end
```

For more information about the **ip auth-proxy auth-proxy-banner** command, see the “Authentication Proxy Commands” section of the [Cisco IOS Security Command Reference](#) on Cisco.com.

Disabling 802.1x Authentication on the Port

You can disable 802.1x authentication on the port by using the **no dot1x pae** interface configuration command.

Beginning in privileged EXEC mode, follow these steps to disable 802.1x authentication on the port. This procedure is optional.

	Command	Purpose
Step 1	configure terminal	Enter global configuration mode.
Step 2	interface <i>interface-id</i>	Specify the port to be configured, and enter interface configuration mode.
Step 3	no dot1x pae	Disable 802.1x authentication on the port.
Step 4	end	Return to privileged EXEC mode.
Step 5	show authentication <i>interface-id</i> or show dot1x interface <i>interface-id</i>	Verify your entries.
Step 6	copy running-config startup-config	(Optional) Save your entries in the configuration file.

To configure the port as an 802.1x port access entity (PAE) authenticator, which enables IEEE 802.1x on the port but does not allow clients connected to the port to be authorized, use the **dot1x pae authenticator** interface configuration command.

This example shows how to disable 802.1x authentication on the port:

```
Switch(config)# interface gigabitethernet2/0/1
Switch(config-if)# no dot1x pae authenticator
```

Resetting the 802.1x Authentication Configuration to the Default Values

Beginning in privileged EXEC mode, follow these steps to reset the 802.1x authentication configuration to the default values. This procedure is optional.

	Command	Purpose
Step 1	configure terminal	Enter global configuration mode.
Step 2	interface <i>interface-id</i>	Enter interface configuration mode, and specify the port to be configured.
Step 3	dot1x default	Reset the 802.1x parameters to the default values.
Step 4	end	Return to privileged EXEC mode.
Step 5	show authentication <i>interface-id</i> or show dot1x interface <i>interface-id</i>	Verify your entries.
Step 6	copy running-config startup-config	(Optional) Save your entries in the configuration file.

Configuring MKA and MACsec

- [Configuring an MKA Policy, page 11-68](#)
- [Configuring MACsec on an Interface, page 11-68](#)

Configuring an MKA Policy

Beginning in privileged EXEC mode, follow these steps to create an MKA Protocol policy:

	Command	Purpose
Step 1	configure terminal	Enter global configuration mode.
Step 2	mka policy <i>policy name</i>	Identify an MKA policy, and enter MKA policy configuration mode. The maximum policy name length is 16 characters.
Step 3	replay-protection window-size <i>frames</i>	Enable replay protection, and configure the window size in number of frames. The range is from 0 to 4294967295. The default window size is 0. Entering a window size of 0 is not the same as entering the no replay-protection command. Configuring a window size of 0 uses replay protection with a strict ordering of frames. Entering no replay-protection turns off MACsec replay-protection.
Step 4	end	Return to privileged EXEC mode.
Step 5	show mka policy	Verify your entries.
Step 6	copy running-config startup-config	(Optional) Save your entries in the configuration file.

This example configures the MKA policy *relay-policy*:

```
Switch(config)# mka policy replay-policy
Switch(config-mka-policy)# replay-protection window-size 300
Switch(config-mka-policy)# end
```

Configuring MACsec on an Interface

Beginning in privileged EXEC mode, follow these steps to configure MACsec on an interface with one MACsec session for voice and one for data:

	Command	Purpose
Step 1	configure terminal	Enter global configuration mode.
Step 2	interface <i>interface-id</i>	Identify the MACsec interface, and enter interface configuration mode. The interface must be a physical interface.
Step 3	switchport access vlan <i>vlan-id</i>	Configure the access VLAN for the port.
Step 4	switchport mode access	Configure the interface as an access port.
Step 5	macsec	Enable 802.1ae MACsec on the interface.
Step 6	authentication event linksec fail action authorize vlan <i>vlan-id</i>	(Optional) Specify that the switch processes authentication link-security failures resulting from unrecognized user credentials by authorizing a restricted VLAN on the port after a failed authentication attempt.

	Command	Purpose
Step 7	authentication host-mode multi-domain	Configure authentication manager mode on the port to allow both a host and a voice device to be authenticated on the 802.1x-authorized port. If not configured, the default host mode is single.
Step 8	authentication linksec policy must-secure	Set the LinkSec security policy to secure the session with MACsec if the peer is available. If not set, the default is <i>should secure</i> .
Step 9	authentication port-control auto	Enable 802.1x authentication on the port. The port changes to the authorized or unauthorized state based on the authentication exchange between the switch and the client
Step 10	authentication violation protect	Configure the port to drop unexpected incoming MAC addresses when a new device connects to a port or when a device connects to a port after the maximum number of devices are connected to that port. If not configured, the default is to shut down the port.
Step 11	mka policy <i>policy name</i>	Apply an existing MKA protocol policy to the interface, and enable MKA on the interface. If no MKA policy was configured (by entering the mka policy global configuration command), you must apply the MKA default policy to the interface by entering the mka default-policy interface configuration command.
Step 12	dot1x pae authenticator	Configure the port as an 802.1x port access entity (PAE) authenticator.
Step 13	spanning-tree portfast	Enable spanning tree Port Fast on the interface in all its associated VLANs. When Port Fast feature is enabled, the interface changes directly from a blocking state to a forwarding state without making the intermediate spanning-tree state changes.
Step 14	end	Return to privileged EXEC mode.
Step 15	show authentication session interface <i>interface-id</i>	Verify the authorized session security status.
Step 16	copy running-config startup-config	(Optional) Save your entries in the configuration file.

This is an example of configuring and verifying MACsec on an interface:

```
Switch(config)# interface GigabitEthernet1/0/25
Switch(config-if)# switchport access vlan 10
Switch(config-if)# switchport mode access
Switch(config-if)# macsec
Switch(config-if)# authentication event linksec fail action authorize vlan 2
Switch(config-if)# authentication host-mode multi-domain
Switch(config-if)# authentication linksec policy must-secure
Switch(config-if)# authentication port-control auto
Switch(config-if)# authentication violation protect
Switch(config-if)# mka policy replay-policy
Switch(config-if)# dot1x pae authenticator
Switch(config-if)# spanning-tree portfast
Switch(config-if)# end
Switch# show authentication sessions interface gigabitethernet1/0/25
Interface: GigabitEthernet1/0/25
MAC Address: 001b.2140.ec3c
IP Address: 1.1.1.103
User-Name: ms1
Status: Authz Success
Domain: DATA
Security Policy: Must Secure β--- New
Security Status: Secured β--- New
Oper host mode: multi-domain
```

```
Oper control dir: both
Authorized By: Authentication Server
Vlan Policy: 10
Session timeout: 3600s (server), Remaining: 3567s
Timeout action: Reauthenticate
Idle timeout: N/A
Common Session ID: 0A05783B0000001700448BA8
Acct Session ID: 0x00000019
Handle: 0x06000017
Runnable methods list:
Method State
dot1x Authc Success
```

Displaying 802.1x Statistics and Status

To display 802.1x statistics for all ports, use the **show dot1x all statistics** privileged EXEC command.

To display 802.1x statistics for a specific port, use the **show dot1x statistics interface *interface-id*** privileged EXEC command.

To display the 802.1x administrative and operational status for the switch, use the **show dot1x all [details | statistics | summary]** privileged EXEC command. To display the 802.1x administrative and operational status for a specific port, use the **show dot1x interface *interface-id*** privileged EXEC command.

For detailed information about the fields in these displays, see the command reference for this release.