



Configuring MSDP

- [Finding Feature Information, on page 1](#)
- [Information About Configuring MSDP, on page 1](#)
- [How to Configure MSDP, on page 4](#)
- [Monitoring and Maintaining MSDP, on page 22](#)
- [Configuration Examples for Configuring MSDP, on page 23](#)

Finding Feature Information

Your software release may not support all the features documented in this module. For the latest caveats and feature information, see Bug Search Tool and the release notes for your platform and software release. To find information about the features documented in this module, and to see a list of the releases in which each feature is supported, see the feature information table at the end of this module.

Use Cisco Feature Navigator to find information about platform support and Cisco software image support. To access Cisco Feature Navigator, go to <http://www.cisco.com/go/cfn>. An account on Cisco.com is not required.

Information About Configuring MSDP

This section describes how to configure the Multicast Source Discovery Protocol (MSDP) on the switch. The MSDP connects multiple Protocol-Independent Multicast sparse-mode (PIM-SM) domains.

MSDP is not fully supported in this software release because of a lack of support for Multicast Border Gateway Protocol (MBGP), which works closely with MSDP. However, it is possible to create default peers that MSDP can operate with if MBGP is not running.



Note To use this feature, the active switch must be running the IP services feature set.

MSDP Overview

MSDP allows multicast sources for a group to be known to all rendezvous points (RPs) in different domains. Each PIM-SM domain uses its own RPs and does not depend on RPs in other domains. An RP runs MSDP over the Transmission Control Protocol (TCP) to discover multicast sources in other domains.

An RP in a PIM-SM domain has an MSDP peering relationship with MSDP-enabled devices in another domain. The peering relationship occurs over a TCP connection, primarily exchanging a list of sources sending to multicast groups. The TCP connections between RPs are achieved by the underlying routing system. The receiving RP uses the source lists to establish a source path.

The purpose of this topology is to have domains discover multicast sources in other domains. If the multicast sources are of interest to a domain that has receivers, multicast data is delivered over the normal, source-tree building mechanism in PIM-SM. MSDP is also used to announce sources sending to a group. These announcements must originate at the domain's RP.

MSDP depends heavily on the Border Gateway Protocol (BGP) or MBGP for interdomain operation. We recommend that you run MSDP in RPs in your domain that are RPs for sources sending to global groups to be announced to the Internet.

MSDP Operation

When a source sends its first multicast packet, the first-hop router (*designated router* or RP) directly connected to the source sends a PIM register message to the RP. The RP uses the register message to register the active source and to forward the multicast packet down the shared tree in the local domain. With MSDP configured, the RP also forwards a source-active (SA) message to all MSDP peers. The SA message identifies the source, the group the source is sending to, and the address of the RP or the originator ID (the IP address of the interface used as the RP address), if configured.

Each MSDP peer receives and forwards the SA message away from the originating RP to achieve peer reverse-path flooding (RPF). The MSDP device examines the BGP or MBGP routing table to discover which peer is the next hop toward the originating RP of the SA message. Such a peer is called an *RPF peer* (reverse-path forwarding peer). The MSDP device forwards the message to all MSDP peers other than the RPF peer. For information on how to configure an MSDP peer when BGP and MBGP are not supported, see the [Configuring a Default MSDP Peer, on page 4](#).

If the MSDP peer receives the same SA message from a non-RPF peer toward the originating RP, it drops the message. Otherwise, it forwards the message to all its MSDP peers.

The RP for a domain receives the SA message from an MSDP peer. If the RP has any join requests for the group the SA message describes and if the (*,G) entry exists with a nonempty outgoing interface list, the domain is interested in the group, and the RP triggers an (S,G) join toward the source. After the (S,G) join reaches the source's DR, a branch of the source tree has been built from the source to the RP in the remote domain. Multicast traffic can now flow from the source across the source tree to the RP and then down the shared tree in the remote domain to the receiver.

Figure 1: MSDP Running Between RP Peers

This figure shows MSDP operating between two MSDP peers. PIM uses MSDP as the standard mechanism to register a source with the RP of a domain. When MSDP is configured, this sequence occurs.

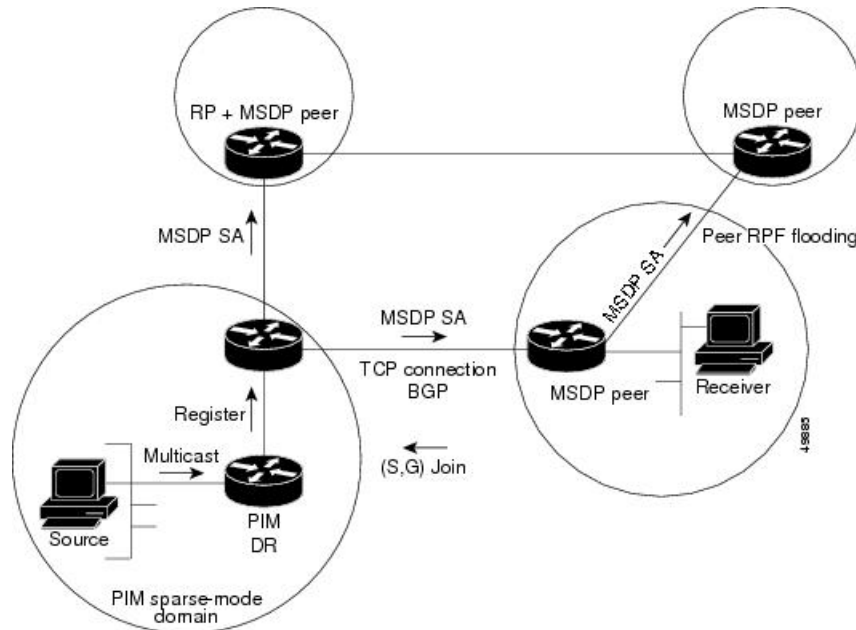

By default, the switch does not cache source or group pairs from received SA messages. When the switch forwards the MSDP SA information, it does not store it in memory. Therefore, if a member joins a group soon after an SA message is received by the local RP, that member needs to wait until the next SA message to hear about the source. This delay is known as join latency.

Local RPs can send SA requests and get immediate responses for all active sources for a given group. By default, the switch does not send any SA request messages to its MSDP peers when a new member joins a group and wants to receive multicast traffic. The new member waits to receive the next periodic SA message.

If you want a new member of a group to learn the active multicast sources in a connected PIM sparse-mode domain that are sending to a group, configure the switch to send SA request messages to the specified MSDP peer when a new member joins a group.

MSDP Benefits

MSDP has these benefits:

- It breaks up the shared multicast distribution tree. You can make the shared tree local to your domain. Your local members join the local tree, and join messages for the shared tree never need to leave your domain.
- PIM sparse-mode domains can rely only on their own RPs, decreasing reliance on RPs in another domain. This increases security because you can prevent your sources from being known outside your domain.
- Domains with only receivers can receive data without globally advertising group membership.
- Global source multicast routing table state is not required, saving memory.

How to Configure MSDP

Default MSDP Configuration

MSDP is not enabled, and no default MSDP peer exists.

Configuring a Default MSDP Peer

Before you begin

Configure an MSDP peer.

Procedure

	Command or Action	Purpose
Step 1	enable Example: Device> enable	Enables privileged EXEC mode. <ul style="list-style-type: none"> • Enter your password if prompted.
Step 2	configure terminal Example: Device# configure terminal	Enters global configuration mode.
Step 3	ip msdp default-peer <i>ip-address</i> <i>name</i> [prefix-list list] Example: Router(config)# ip msdp default-peer 10.1.1.1 prefix-list site-a	Defines a default peer from which to accept all MSDP SA messages. <ul style="list-style-type: none"> • For <i>ip-address</i> <i>name</i>, enter the IP address or Domain Name System (DNS) server name of the MSDP default peer. • (Optional) For prefix-list list, enter the list name that specifies the peer to be the default peer only for the listed prefixes. You can have multiple active default peers when you have a prefix list associated with each. <p>When you enter multiple ip msdp default-peer commands with the prefix-list keyword, you use all the default peers at the same time for different RP prefixes. This syntax is typically used in a service provider cloud that connects stub site clouds.</p>

	Command or Action	Purpose
		When you enter multiple ip msdp default-peer commands without the prefix-list keyword, a single active peer accepts all SA messages. If that peer fails, the next configured default peer accepts all SA messages. This syntax is typically used at a stub site.
Step 4	<p>ip prefix-list <i>name</i> [description <i>string</i>] seq number {permit deny} <i>network length</i></p> <p>Example:</p> <pre>Router(config)# ip prefix-list site-a seq 3 permit 12 network length 128</pre>	<p>(Optional) Creates a prefix list using the name specified in Step 2.</p> <ul style="list-style-type: none"> • (Optional) For description <i>string</i>, enter a description of up to 80 characters to describe this prefix list. • For seq number, enter the sequence number of the entry. The range is 1 to 4294967294. • The deny keyword denies access to matching conditions. • The permit keyword permits access to matching conditions. • For <i>network length</i>, specify the network number and length (in bits) of the network mask that is permitted or denied.
Step 5	<p>ip msdp description {<i>peer-name</i> <i>peer-address</i>} <i>text</i></p> <p>Example:</p> <pre>Router(config)# ip msdp description peer-name site-b</pre>	<p>(Optional) Configures a description for the specified peer to make it easier to identify in a configuration or in show command output.</p> <p>By default, no description is associated with an MSDP peer.</p>
Step 6	<p>end</p> <p>Example:</p> <pre>Device(config)# end</pre>	Returns to privileged EXEC mode.
Step 7	<p>show running-config</p> <p>Example:</p> <pre>Device# show running-config</pre>	Verifies your entries.
Step 8	<p>copy running-config startup-config</p> <p>Example:</p>	(Optional) Saves your entries in the configuration file.

	Command or Action	Purpose
	Device# <code>copy running-config startup-config</code>	

Caching Source-Active State

If you want to sacrifice some memory in exchange for reducing the latency of the source information, you can configure the Device to cache SA messages. Perform the following steps to enable the caching of source/group pairs:

Follow these steps to enable the caching of source/group pairs:

Procedure

	Command or Action	Purpose
Step 1	<p>enable</p> <p>Example:</p> <pre>Device> enable</pre>	<p>Enables privileged EXEC mode.</p> <ul style="list-style-type: none"> • Enter your password if prompted.
Step 2	<p>configure terminal</p> <p>Example:</p> <pre>Device# configure terminal</pre>	<p>Enters global configuration mode.</p>
Step 3	<p>ip msdp cache-sa-state [list access-list-number]</p> <p>Example:</p> <pre>Device(config)# ip msdp cache-sa-state 100</pre>	<p>Enables the caching of source/group pairs (create an SA state). Those pairs that pass the access list are cached.</p> <p>For list access-list-number, the range is 100 to 199.</p> <p>Note An alternative to this command is the ip msdp sa-reques global configuration command, which causes the Device to send an SA request message to the MSDP peer when a new member for a group becomes active.</p>
Step 4	<p>access-list access-list-number {deny permit} protocol source source-wildcard destination destination-wildcard</p> <p>Example:</p> <pre>Device(config)# access-list 100 permit</pre>	<p>Creates an IP extended access list, repeating the command as many times as necessary.</p> <ul style="list-style-type: none"> • For access-list-number, the range is 100 to 199. Enter the same number created in Step 2.

	Command or Action	Purpose
	<pre>ip 171.69.0.0 0.0.255.255 224.2.0.0 0.0.255.255</pre>	<ul style="list-style-type: none"> • The deny keyword denies access if the conditions are matched. The permit keyword permits access if the conditions are matched. • For <i>protocol</i>, enter ip as the protocol name. • For <i>source</i>, enter the number of the network or host from which the packet is being sent. • For <i>source-wildcard</i>, enter the wildcard bits in dotted decimal notation to be applied to the source. Place ones in the bit positions that you want to ignore. • For <i>destination</i>, enter the number of the network or host to which the packet is being sent. • For <i>destination-wildcard</i>, enter the wildcard bits in dotted decimal notation to be applied to the destination. Place ones in the bit positions that you want to ignore. <p>Recall that the access list is always terminated by an implicit deny statement for everything.</p>
Step 5	<p>end</p> <p>Example:</p> <pre>Device(config)# end</pre>	Returns to privileged EXEC mode.
Step 6	<p>show running-config</p> <p>Example:</p> <pre>Device# show running-config</pre>	Verifies your entries.
Step 7	<p>copy running-config startup-config</p> <p>Example:</p> <pre>Device# copy running-config startup-config</pre>	(Optional) Saves your entries in the configuration file.

Controlling Source Information that Your Switch Originates

You can control the multicast source information that originates with your Device:

- Sources you advertise (based on your sources)
- Receivers of source information (based on knowing the requestor)

For more information, see the [Redistributing Sources, on page 8](#) and the [Filtering Source-Active Request Messages, on page 10](#).

Redistributing Sources

SA messages originate on RPs to which sources have registered. By default, any source that registers with an RP is advertised. The *A flag* is set in the RP when a source is registered, which means the source is advertised in an SA unless it is filtered.

Follow these steps to further restrict which registered sources are advertised:

Procedure

	Command or Action	Purpose
Step 1	<p>enable</p> <p>Example:</p> <pre>Device> enable</pre>	<p>Enables privileged EXEC mode.</p> <ul style="list-style-type: none"> • Enter your password if prompted.
Step 2	<p>configure terminal</p> <p>Example:</p> <pre>Device# configure terminal</pre>	<p>Enters global configuration mode.</p>
Step 3	<p>ip msdp redistribute [list access-list-name] [asn aspath-access-list-number] [route-map map]</p> <p>Example:</p> <pre>Device(config)# ip msdp redistribute list 21</pre>	<p>Configures which (S,G) entries from the multicast routing table are advertised in SA messages.</p> <p>By default, only sources within the local domain are advertised.</p> <ul style="list-style-type: none"> • (Optional) list access-list-name— Enters the name or number of an IP standard or extended access list. The range is 1 to 99 for standard access lists and 100 to 199 for extended lists. The access list controls which local sources are advertised and to which groups they send. • (Optional) asn aspath-access-list-number—Enters the IP standard or extended access list number in the range 1 to 199. This access list number must also be configured in the ip as-path access-list command.

	Command or Action	Purpose
		<ul style="list-style-type: none"> • (Optional) route-map map—Enters the IP standard or extended access list number in the range 1 to 199. This access list number must also be configured in the ip as-path access-list command. <p>The Device advertises (S,G) pairs according to the access list or autonomous system path access list.</p>
<p>Step 4</p>	<p>Use one of the following:</p> <ul style="list-style-type: none"> • <code>access-list <i>access-list-number</i> {deny permit} <i>source</i> [<i>source-wildcard</i>]</code> • <code>access-list <i>access-list-number</i> {deny permit} <i>protocol source source-wildcard destination destination-wildcard</i></code> <p>Example:</p> <pre>Device(config)# access list 21 permit 194.1.22.0</pre> <p>or</p> <pre>Device(config)# access list 21 permit ip 194.1.22.0 1.1.1.1 194.3.44.0 1.1.1.1</pre>	<p>Creates an IP standard access list, repeating the command as many times as necessary.</p> <p>or</p> <p>Creates an IP extended access list, repeating the command as many times as necessary.</p> <ul style="list-style-type: none"> • <i>access-list-number</i>—Enters the same number created in Step 2. The range is 1 to 99 for standard access lists and 100 to 199 for extended lists. • deny—Denies access if the conditions are matched. The permit keyword permits access if the conditions are matched. • <i>protocol</i>—Enters ip as the protocol name. • <i>source</i>—Enters the number of the network or host from which the packet is being sent. • <i>source-wildcard</i>—Enters the wildcard bits in dotted decimal notation to be applied to the source. Place ones in the bit positions that you want to ignore. • <i>destination</i>—Enters the number of the network or host to which the packet is being sent. • <i>destination-wildcard</i>—Enters the wildcard bits in dotted decimal notation to be applied to the destination. Place ones in the bit positions that you want to ignore. <p>Recall that the access list is always terminated by an implicit deny statement for everything.</p>
<p>Step 5</p>	<p>end</p> <p>Example:</p>	<p>Returns to privileged EXEC mode.</p>

	Command or Action	Purpose
	Device(config)# end	
Step 6	show running-config Example: Device# show running-config	Verifies your entries.
Step 7	copy running-config startup-config Example: Device# copy running-config startup-config	(Optional) Saves your entries in the configuration file.

Filtering Source-Active Request Messages

By default, only Device that are caching SA information can respond to SA requests. By default, such a Device honors all SA request messages from its MSDP peers and supplies the IP addresses of the active sources.

However, you can configure the Device to ignore all SA requests from an MSDP peer. You can also honor only those SA request messages from a peer for groups described by a standard access list. If the groups in the access list pass, SA request messages are accepted. All other such messages from the peer for other groups are ignored.

To return to the default setting, use the **no ip msdp filter-sa-request** *{ip-address| name}* global configuration command.

Follow these steps to configure one of these options:

Procedure

	Command or Action	Purpose
Step 1	enable Example: Device> enable	Enables privileged EXEC mode. <ul style="list-style-type: none"> • Enter your password if prompted.
Step 2	configure terminal Example: Device# configure terminal	Enters global configuration mode.
Step 3	Use one of the following: <ul style="list-style-type: none"> • ip msdp filter-sa-request <i>{ip-addressname}</i> 	Filters all SA request messages from the specified MSDP peer. or

	Command or Action	Purpose
	<ul style="list-style-type: none"> <code>ip msdp filter-sa-request {ip-addressname} list access-list-number</code> <p>Example:</p> <pre>Device(config)# ip msdp filter sa-request 171.69.2.2</pre>	Filters SA request messages from the specified MSDP peer for groups that pass the standard access list. The access list describes a multicast group address. The range for the access-list-number is 1 to 99.
Step 4	<p><code>access-list access-list-number {deny permit} source [source-wildcard]</code></p> <p>Example:</p> <pre>Device(config)# access-list 1 permit 192.4.22.0 0.0.0.255</pre>	<p>Creates an IP standard access list, repeating the command as many times as necessary.</p> <ul style="list-style-type: none"> For <i>access-list-number</i>, the range is 1 to 99. The deny keyword denies access if the conditions are matched. The permit keyword permits access if the conditions are matched. For <i>source</i>, enter the number of the network or host from which the packet is being sent. (Optional) For <i>source-wildcard</i>, enter the wildcard bits in dotted decimal notation to be applied to the source. Place ones in the bit positions that you want to ignore. <p>Recall that the access list is always terminated by an implicit deny statement for everything.</p>
Step 5	<p><code>end</code></p> <p>Example:</p> <pre>Device(config)# end</pre>	Returns to privileged EXEC mode.
Step 6	<p><code>show running-config</code></p> <p>Example:</p> <pre>Device# show running-config</pre>	Verifies your entries.
Step 7	<p><code>copy running-config startup-config</code></p> <p>Example:</p> <pre>Device# copy running-config startup-config</pre>	(Optional) Saves your entries in the configuration file.

Controlling Source Information that Your Switch Forwards

By default, the Device forwards all SA messages it receives to all its MSDP peers. However, you can prevent outgoing messages from being forwarded to a peer by using a filter or by setting a time-to-live (TTL) value.

Using a Filter

By creating a filter, you can perform one of these actions:

- Filter all source/group pairs
- Specify an IP extended access list to pass only certain source/group pairs
- Filter based on match criteria in a route map

Follow these steps to apply a filter:

Procedure

	Command or Action	Purpose
Step 1	<p>enable</p> <p>Example:</p> <pre>Device> enable</pre>	<p>Enables privileged EXEC mode.</p> <ul style="list-style-type: none"> • Enter your password if prompted.
Step 2	<p>configure terminal</p> <p>Example:</p> <pre>Device# configure terminal</pre>	<p>Enters global configuration mode.</p>
Step 3	<p>Use one of the following:</p> <ul style="list-style-type: none"> • ip msdp sa-filter out <pre>{ip-address name}</pre> <ul style="list-style-type: none"> • ip msdp sa-filter out <pre>{ip-address name} list access-list-number</pre> <ul style="list-style-type: none"> • ip msdp sa-filter out <pre>{ip-address name} route-map map-tag</pre> <p>Example:</p> <pre>Device(config)# ip msdp sa-filter out switch.cisco.com</pre> <p>or</p>	<ul style="list-style-type: none"> • Filters all SA messages to the specified MSDP peer. • Passes only those SA messages that pass the IP extended access list to the specified peer. The range for the extended <i>access-list-number</i> is 100 to 199. <p>If both the list and the route-map keywords are used, all conditions must be true to pass any (S,G) pair in outgoing SA messages.</p> <ul style="list-style-type: none"> • Passes only those SA messages that meet the match criteria in the route map <i>map-tag</i> to the specified MSDP peer. <p>If all match criteria are true, a permit from the route map passes routes through the filter. A deny filters routes.</p>

	Command or Action	Purpose
	<pre>Device(config)# ip msdp sa-filter out list 100</pre> <p>or</p> <pre>Device(config)# ip msdp sa-filter out switch.cisco.com route-map 22</pre>	
Step 4	<p>access-list <i>access-list-number</i> {deny permit} <i>protocol source source-wildcard destination-wildcard</i></p> <p>Example:</p> <pre>Device(config)# access list 100 permit ip 194.1.22.0 1.1.1.1 194.3.44.0 1.1.1.1</pre>	<p>(Optional) Creates an IP extended access list, repeating the command as many times as necessary.</p> <ul style="list-style-type: none"> • For <i>access-list-number</i>, enter the number specified in Step 2. • The deny keyword denies access if the conditions are matched. The permit keyword permits access if the conditions are matched. • For <i>protocol</i>, enter ip as the protocol name. • For <i>source</i>, enter the number of the network or host from which the packet is being sent. • For <i>source-wildcard</i>, enter the wildcard bits in dotted decimal notation to be applied to the source. Place ones in the bit positions that you want to ignore. • For <i>destination</i>, enter the number of the network or host to which the packet is being sent. • For <i>destination-wildcard</i>, enter the wildcard bits in dotted decimal notation to be applied to the destination. Place ones in the bit positions that you want to ignore. <p>Recall that the access list is always terminated by an implicit deny statement for everything.</p>
Step 5	<p>end</p> <p>Example:</p> <pre>Device(config)# end</pre>	Returns to privileged EXEC mode.
Step 6	<p>show running-config</p> <p>Example:</p>	Verifies your entries.

	Command or Action	Purpose
	Device# <code>show running-config</code>	
Step 7	copy running-config startup-config Example: Device# <code>copy running-config startup-config</code>	(Optional) Saves your entries in the configuration file.

Using TTL to Limit the Multicast Data Sent in SA Messages

You can use a TTL value to control what data is encapsulated in the first SA message for every source. Only multicast packets with an IP-header TTL greater than or equal to the *tll* argument are sent to the specified MSDP peer. For example, you can limit internal traffic to a TTL of 8. If you want other groups to go to external locations, you must send those packets with a TTL greater than 8.

Follow these steps to establish a TTL threshold:

Procedure

	Command or Action	Purpose
Step 1	enable Example: Device> <code>enable</code>	Enables privileged EXEC mode. <ul style="list-style-type: none"> • Enter your password if prompted.
Step 2	configure terminal Example: Device# <code>configure terminal</code>	Enters global configuration mode.
Step 3	ip msdp ttl-threshold {ip-address name} ttl Example: Device(config)# <code>ip msdp ttl-threshold switch.cisco.com 0</code>	Limits which multicast data is encapsulated in the first SA message to the specified MSDP peer. <ul style="list-style-type: none"> • For <i>ip-address name</i>, enter the IP address or name of the MSDP peer to which the TTL limitation applies. • For <i>tll</i>, enter the TTL value. The default is 0, which means all multicast data packets are forwarded to the peer until the TTL is exhausted. The range is 0 to 255.
Step 4	end Example:	Returns to privileged EXEC mode.

	Command or Action	Purpose
	Device(config)# end	
Step 5	show running-config Example: Device# show running-config	Verifies your entries.
Step 6	copy running-config startup-config Example: Device# copy running-config startup-config	(Optional) Saves your entries in the configuration file.

Controlling Source Information that Your Switch Receives

By default, the Device receives all SA messages that its MSDP RPF peers send to it. However, you can control the source information that you receive from MSDP peers by filtering incoming SA messages. In other words, you can configure the Device to not accept them.

You can perform one of these actions:

- Filter all incoming SA messages from an MSDP peer
- Specify an IP extended access list to pass certain source/group pairs
- Filter based on match criteria in a route map

Follow these steps to apply a filter:

Procedure

	Command or Action	Purpose
Step 1	enable Example: Device> enable	Enables privileged EXEC mode. <ul style="list-style-type: none"> • Enter your password if prompted.
Step 2	configure terminal Example: Device# configure terminal	Enters global configuration mode.
Step 3	Use one of the following: <ul style="list-style-type: none"> • ip msdp sa-filter in 	<ul style="list-style-type: none"> • Filters all SA messages to the specified MSDP peer.

	Command or Action	Purpose
	<pre>{ip-address name} • ip msdp sa-filter in {ip-address name} list access-list-number • ip msdp sa-filter in {ip-address name} route-map map-tag</pre> <p>Example:</p> <pre>Device(config)# ip msdp sa-filter in switch.cisco.com</pre> <p>OR</p> <pre>Device(config)# ip msdp sa-filter in list 100</pre> <p>OR</p> <pre>Device(config)# ip msdp sa-filter in switch.cisco.com route-map 22</pre>	<ul style="list-style-type: none"> • Passes only those SA messages from the specified peer that pass the IP extended access list. The range for the extended <i>access-list-number</i> is 100 to 199. <p>If both the list and the route-map keywords are used, all conditions must be true to pass any (S,G) pair in outgoing SA messages.</p> <ul style="list-style-type: none"> • Passes only those SA messages from the specified MSDP peer that meet the match criteria in the route map <i>map-tag</i>. <p>If all match criteria are true, a permit from the route map passes routes through the filter. A deny filters routes.</p>
Step 4	<pre>access-list access-list-number {deny permit} protocol source source-wildcard destination destination-wildcard</pre> <p>Example:</p> <pre>Device(config)# access list 100 permit ip 194.1.22.0 1.1.1.1 194.3.44.0 1.1.1.1</pre>	<p>(Optional) Creates an IP extended access list, repeating the command as many times as necessary.</p> <ul style="list-style-type: none"> • <i>access-list-number</i>, enter the number specified in Step 2. • The deny keyword denies access if the conditions are matched. The permit keyword permits access if the conditions are matched. • For <i>protocol</i>, enter ip as the protocol name. • For <i>source</i>, enter the number of the network or host from which the packet is being sent. • For <i>source-wildcard</i>, enter the wildcard bits in dotted decimal notation to be applied to the source. Place ones in the bit positions that you want to ignore. • For <i>destination</i>, enter the number of the network or host to which the packet is being sent. • For <i>destination-wildcard</i>, enter the wildcard bits in dotted decimal notation to

	Command or Action	Purpose
		<p>be applied to the destination. Place ones in the bit positions that you want to ignore.</p> <p>Recall that the access list is always terminated by an implicit deny statement for everything.</p>
Step 5	end Example: <pre>Device(config)# end</pre>	Returns to privileged EXEC mode.
Step 6	show running-config Example: <pre>Device# show running-config</pre>	Verifies your entries.
Step 7	copy running-config startup-config Example: <pre>Device# copy running-config startup-config</pre>	(Optional) Saves your entries in the configuration file.

Configuring an MSDP Mesh Group

An MSDP mesh group is a group of MSDP speakers that have fully meshed MSDP connectivity among one another. Any SA messages received from a peer in a mesh group are not forwarded to other peers in the same mesh group. Thus, you reduce SA message flooding and simplify peer-RPF flooding. Use the **ip msdp mesh-group** global configuration command when there are multiple RPs within a domain. It is especially used to send SA messages across a domain. You can configure multiple mesh groups (with different names) in a single Device.

Follow these steps to create a mesh group:

Procedure

	Command or Action	Purpose
Step 1	enable Example: <pre>Device> enable</pre>	Enables privileged EXEC mode. <ul style="list-style-type: none"> • Enter your password if prompted.
Step 2	configure terminal Example:	Enters global configuration mode.

	Command or Action	Purpose
	Device# <code>configure terminal</code>	
Step 3	<p>ip msdp mesh-group <i>name</i> {<i>ip-address</i> <i>name</i>}</p> <p>Example:</p> <pre>Device(config)# ip msdp mesh-group 2 switch.cisco.com</pre>	<p>Configures an MSDP mesh group, and specifies the MSDP peer belonging to that mesh group.</p> <p>By default, the MSDP peers do not belong to a mesh group.</p> <ul style="list-style-type: none"> • For <i>name</i>, enter the name of the mesh group. • For <i>ip-address</i> <i>name</i>, enter the IP address or name of the MSDP peer to be a member of the mesh group. <p>Repeat this procedure on each MSDP peer in the group.</p>
Step 4	<p>end</p> <p>Example:</p> <pre>Device(config)# end</pre>	Returns to privileged EXEC mode.
Step 5	<p>show running-config</p> <p>Example:</p> <pre>Device# show running-config</pre>	Verifies your entries.
Step 6	<p>copy running-config startup-config</p> <p>Example:</p> <pre>Device# copy running-config startup-config</pre>	(Optional) Saves your entries in the configuration file.

Shutting Down an MSDP Peer

If you want to configure many MSDP commands for the same peer and you do not want the peer to become active, you can shut down the peer, configure it, and later bring it up. When a peer is shut down, the TCP connection is terminated and is not restarted. You can also shut down an MSDP session without losing configuration information for the peer.

Follow these steps to shut down a peer:

Procedure

	Command or Action	Purpose
Step 1	enable Example: Device> enable	Enables privileged EXEC mode. • Enter your password if prompted.
Step 2	configure terminal Example: Device# configure terminal	Enters global configuration mode.
Step 3	ip msdp shutdown { <i>peer-name</i> <i>peer address</i> } Example: Device(config)# ip msdp shutdown switch.cisco.com	Shuts down the specified MSDP peer without losing configuration information. For <i>peer-name</i> <i>peer address</i> , enter the IP address or name of the MSDP peer to shut down.
Step 4	end Example: Device(config)# end	Returns to privileged EXEC mode.
Step 5	show running-config Example: Device# show running-config	Verifies your entries.
Step 6	copy running-config startup-config Example: Device# copy running-config startup-config	(Optional) Saves your entries in the configuration file.

Including a Bordering PIM Dense-Mode Region in MSDP

You can configure MSDP on a Device that borders a PIM sparse-mode region with a dense-mode region. By default, active sources in the dense-mode region do not participate in MSDP.



Note We do not recommend using the **ip msdp border sa-address** global configuration command. It is better to configure the border router in the sparse-mode domain to proxy-register sources in the dense-mode domain to the RP of the sparse-mode domain and have the sparse-mode domain use standard MSDP procedures to advertise these sources.

The **ip msdp originator-id** global configuration command also identifies an interface to be used as the RP address. If both the **ip msdp border sa-address** and the **ip msdp originator-id** global configuration commands are configured, the address derived from the **ip msdp originator-id** command specifies the RP address.

Follow these steps to configure the border router to send SA messages for sources active in the dense-mode region to the MSDP peers:

Procedure

	Command or Action	Purpose
Step 1	enable Example: Device> enable	Enables privileged EXEC mode. <ul style="list-style-type: none"> • Enter your password if prompted.
Step 2	configure terminal Example: Device# configure terminal	Enters global configuration mode.
Step 3	ip msdp border sa-address <i>interface-id</i> Example: Device(config)# ip msdp border sa-address 0/1	Configures the switch on the border between a dense-mode and sparse-mode region to send SA messages about active sources in the dense-mode region. For <i>interface-id</i> , specifies the interface from which the IP address is derived and used as the RP address in SA messages. The IP address of the interface is used as the Originator-ID, which is the RP field in the SA message.
Step 4	ip msdp redistribute [list <i>access-list-name</i>] [asn <i>aspath-access-list-number</i>] [route-map <i>map</i>] Example: Device(config)# ip msdp redistribute list 100	Configures which (S,G) entries from the multicast routing table are advertised in SA messages. For more information, see the Redistributing Sources, on page 8 .

	Command or Action	Purpose
Step 5	end Example: Device(config)# end	Returns to privileged EXEC mode.
Step 6	show running-config Example: Device# show running-config	Verifies your entries.
Step 7	copy running-config startup-config Example: Device# copy running-config startup-config	(Optional) Saves your entries in the configuration file.

Configuring an Originating Address other than the RP Address

You can allow an MSDP speaker that originates an SA message to use the IP address of the interface as the RP address in the SA message by changing the Originator ID. You might change the Originator ID in one of these cases:

- If you configure a logical RP on multiple Device in an MSDP mesh group.
- If you have a Device that borders a PIM sparse-mode domain and a dense-mode domain. If a Device borders a dense-mode domain for a site, and sparse-mode is being used externally, you might want dense-mode sources to be known to the outside world. Because this Device is not an RP, it would not have an RP address to use in an SA message. Therefore, this command provides the RP address by specifying the address of the interface.

If both the **ip msdp border sa-address** and the **ip msdp originator-id** global configuration commands are configured, the address derived from the **ip msdp originator-id** command specifies the address of the RP.

Follow these steps to allow an MSDP speaker that originates an SA message to use the IP address on the interface as the RP address in the SA message:

Procedure

	Command or Action	Purpose
Step 1	enable Example: Device> enable	Enables privileged EXEC mode. <ul style="list-style-type: none"> • Enter your password if prompted.

	Command or Action	Purpose
Step 2	<p>configure terminal</p> <p>Example:</p> <pre>Device# configure terminal</pre>	Enters global configuration mode.
Step 3	<p>ip msdp originator-id <i>interface-id</i></p> <p>Example:</p> <pre>Device(config)# ip msdp originator-id 0/1</pre>	<p>Configures the RP address in SA messages to be the address of the originating device interface.</p> <p>For <i>interface-id</i>, specify the interface on the local Device.</p>
Step 4	<p>end</p> <p>Example:</p> <pre>Device(config)# end</pre>	Returns to privileged EXEC mode.
Step 5	<p>show running-config</p> <p>Example:</p> <pre>Device# show running-config</pre>	Verifies your entries.
Step 6	<p>copy running-config startup-config</p> <p>Example:</p> <pre>Device# copy running-config startup-config</pre>	(Optional) Saves your entries in the configuration file.

Monitoring and Maintaining MSDP

Commands that monitor MSDP SA messages, peers, state, and peer status:

Table 1: Commands for Monitoring and Maintaining MSDP

Command	Purpose
debug ip msdp [<i>peer-address</i> <i>name</i>] [detail] [routes]	Debugs an MSDP activity.
debug ip msdp resets	Debugs MSDP peer reset reasons.

Command	Purpose
show ip msdp count [<i>autonomous-system-number</i>]	Displays the number of sources and groups originated in SA messages from each autonomous system. The ip msdp cache-sa-state command must be configured for this command to produce any output.
show ip msdp peer [<i>peer-address</i> <i>name</i>]	Displays detailed information about an MSDP peer.
show ip msdp sa-cache [<i>group-address</i> <i>source-address</i> <i>group-name</i> <i>source-name</i>] [<i>autonomous-system-number</i>]	Displays (S,G) state learned from MSDP peers.
show ip msdp summary	Displays MSDP peer status and SA message counts.

Commands that clear MSDP connections, statistics, and SA cache entries:

Table 2: Commands for Clearing MSDP Connections, Statistics, or SA Cache Entries

Command	Purpose
clear ip msdp peer <i>peer-address</i> <i>name</i>	Clears the TCP connection to the specified MSDP peer, resetting all MSDP message counters.
clear ip msdp statistics [<i>peer-address</i> <i>name</i>]	Clears statistics counters for one or all the MSDP peers without resetting the sessions.
clear ip msdp sa-cache [<i>group-address</i> <i>name</i>]	Clears the SA cache entries for all entries, all sources for a specific group, or all entries for a specific source/group pair.

Configuration Examples for Configuring MSDP

Configuring a Default MSDP Peer: Example

This example shows a partial configuration of Router A and Router C in . Each of these ISPs have more than one customer (like the customer in) who use default peering (no BGP or MBGP). In that case, they might have similar configurations. That is, they accept SAs only from a default peer if the SA is permitted by the corresponding prefix list.

Router A

```
Router(config)# ip msdp default-peer 10.1.1.1
Router(config)# ip msdp default-peer 10.1.1.1 prefix-list site-a
Router(config)# ip prefix-list site-b permit 10.0.0.0/1
```

Router C

```
Router(config)# ip msdp default-peer 10.1.1.1 prefix-list site-a
Router(config)# ip prefix-list site-b permit 10.0.0.0/1
```

Caching Source-Active State: Example

This example shows how to enable the cache state for all sources in 171.69.0.0/16 sending to groups 224.2.0.0/16:

```
Device(config)# ip msdp cache-sa-state 100
Device(config)# access-list 100 permit ip 171.69.0.0 0.0.255.255 224.2.0.0 0.0.255.255
```

Controlling Source Information that Your Switch Originates: Example

This example shows how to configure the switch to filter SA request messages from the MSDP peer at 171.69.2.2. SA request messages from sources on network 192.4.22.0 pass access list 1 and are accepted; all others are ignored.

```
Device(config)# ip msdp filter sa-request 171.69.2.2 list 1
Device(config)# access-list 1 permit 192.4.22.0 0.0.0.255
```

Controlling Source Information that Your Switch Forwards: Example

This example shows how to allow only (S,G) pairs that pass access list 100 to be forwarded in an SA message to the peer named *switch.cisco.com*:

```
Device(config)# ip msdp peer switch.cisco.com connect-source gigabitethernet1/0/1
Device(config)# ip msdp sa-filter out switch.cisco.com list 100
Device(config)# access-list 100 permit ip 171.69.0.0 0.0.255.255 224.2.0.0 0.0.255.255
```

Controlling Source Information that Your Switch Receives: Example

This example shows how to filter all SA messages from the peer named *switch.cisco.com*:

```
Device(config)# ip msdp peer switch.cisco.com connect-source gigabitethernet1/0/1
Device(config)# ip msdp sa-filter in switch.cisco.com
```