



Configuring Cisco NSF with SSO Supervisor Engine Redundancy

This chapter describes how to configure supervisor engine redundancy using Cisco nonstop forwarding (NSF) with stateful switchover (SSO).

This chapter consists of these sections:

- [Understanding NSF with SSO Supervisor Engine Redundancy, page 9-1](#)
- [Configuring NSF with SSO Supervisor Engine Redundancy, page 9-9](#)

**Note**

For complete syntax and usage information for the switch commands used in this chapter, look at the *Cisco Catalyst 4500 Series Switch Command Reference* and related publications at this location:

<http://www.cisco.com/en/US/products/hw/switches/ps4324/index.html>

If the command is not found in the Catalyst 4500 Command Reference, it is located in the larger Cisco IOS library. Refer to the *Catalyst 4500 Series Switch Cisco IOS Command Reference*, Release 12.2(37)SG and related publications at this location:

<http://www.cisco.com/en/US/products/ps6350/index.html>

Understanding NSF with SSO Supervisor Engine Redundancy

These sections describe supervisor engine redundancy using NSF with SSO:

- [Understanding Cisco IOS NSF-Aware and NSF-Capable Support, page 9-2](#)
- [NSF with SSO Supervisor Engine Redundancy Overview, page 9-4](#)
- [SSO Operation, page 9-4](#)
- [NSF Operation, page 9-5](#)
- [Cisco Express Forwarding, page 9-5](#)
- [Routing Protocols, page 9-5](#)
- [NSF Guidelines and Restrictions, page 9-9](#)

Understanding Cisco IOS NSF-Aware and NSF-Capable Support

Cisco IOS Nonstop Forwarding (NSF) has two primary components:

NSF-awareness—If neighboring router devices detect that an NSF router can still forward packets when a supervisor engine switchover happens, this capability is referred to as NSF-awareness. Cisco IOS enhancements to the Layer 3 routing protocols (OSPF, BGP, EIGRP and IS-IS) are designed to prevent route-flapping so that the CEF routing table does not time out or the NSF router does not drop routes. An NSF-aware router helps to send routing protocol information to the neighboring NSF router.

NSF-capability—NSF works with SSO to minimize the amount of time that a Layer 3 network is unavailable following a supervisor engine switchover by continuing to forward IP packets. Reconvergence of Layer 3 routing protocols (BGP, EIGRP, OSPF v2, and IS-IS) is transparent to the user and happens automatically in the background. The routing protocols recover routing information from neighbor devices and rebuild the Cisco Express Forwarding (CEF) table.



Note NSF does not support VRF and IPv6.



Note NSF capable devices include Catalyst 4500 series switches, Catalyst 6500 series switches, Cisco 7500 series routers, Cisco 10000 series routers, and Cisco 12000 series routers.

A typical topology for NSF and NSF-aware routers is given below.

Figure 9-1 Topology for NSF and NSF-Capable Switches

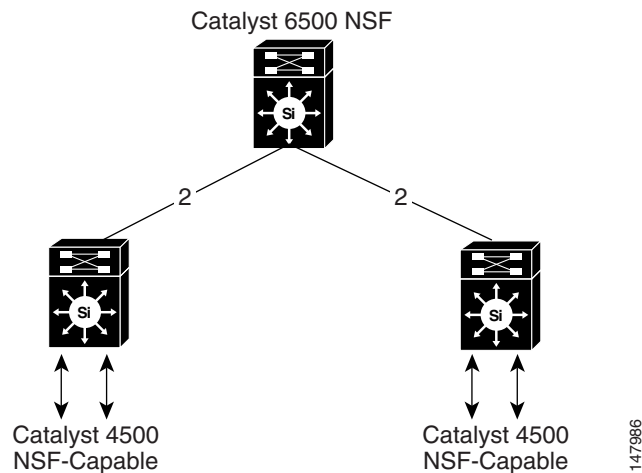

Table 9-1 lists the supervisor engines and Catalyst 4500 series switches that support NSF-awareness:

Table 9-1 NSF-Aware Supervisor Engines

NSF-Aware Supervisor Engine	Switch Support
Supervisor Engine II-Plus (WS-X4013)	Catalyst 4507R series switch, Catalyst 4506 series switch, and Catalyst 4503 series switch
Supervisor Engine II-Plus+TS (WS-X4013+TS)	Catalyst 4507R series switch, Catalyst 4506 series switch, and Catalyst 4503 series switch
Supervisor Engine II-Plus+10GE (WS-X4013+10GE)	Catalyst 4507R series switch, Catalyst 4506 series switch, and Catalyst 4503 series switch
Supervisor Engine IV (WS-X4515)	Catalyst 4507R series switch, Catalyst 4506 series switch, and Catalyst 4503 series switch
Supervisor Engine V (WS-X4516)	Catalyst 4507R series switch and Catalyst 4510R series switch
Supervisor Engine V-10GE (WS-X4516-10GE)	Catalyst 4506 series switch, Catalyst 4507R series switch, and Catalyst 4510R series switch
Fixed Switchs (WS-C4948 and WS-C4948-10GE)	Catalyst 4948 and 4948-10GE switches

Starting with Cisco IOS Release 12.2(20)EWA, the Catalyst 4500 series switch supported NSF-awareness for the EIGRP, IS-IS, OSPF and BGP protocols. Starting with Cisco IOS Release 12.2(31)SG, the Catalyst 4500 series switch supported NSF-awareness for the EIGRP-stub in IP Base image for all supervisor engines. NSF-awareness is turned on by default for EIGRP-stub, EIGRP, IS-IS and OSPF protocols. For BGP, you need to turned it on manually.

If the supervisor engine is configured for BGP (with the **graceful-restart** command), EIGRP, OSPF or IS-IS routing protocols, routing updates are automatically sent during the supervisor engine switchover of a neighboring NSF capable switch (typically a Catalyst 6500 series switch).

Starting with Cisco IOS Release 12.2(31)SG, the Catalyst 4500 series switch supports NSF-capability. Table 9-2 lists the supervisor engines and Catalyst 4500 series switches that support NSF-capable:

Table 9-2 NSF-Capable Supervisor Engines

NSF-Capable Supervisor Engine	Switch Support
Supervisor Engine IV (WS-X4515)	Catalyst 4507R series switch
Supervisor Engine V (WS-X4516)	Catalyst 4507R series switch and Catalyst 4510R series switch
Supervisor Engine V-10GE (WS-X4516-10GE)	Catalyst 4507R series switch and Catalyst 4510R series switch

NSF with SSO Supervisor Engine Redundancy Overview

Catalyst 4500 series switches support fault resistance by allowing a redundant supervisor engine to take over if the primary supervisor engine fails. NSF works with SSO to minimize the amount of time a network is unavailable to its users following a switchover.

NSF provides these benefits:

- Improved network availability

NSF continues forwarding network traffic and application state information so that user session information is maintained after a switchover.
- Overall network stability

Network stability may be improved with the reduction in the number of route flaps, which were created when routers in the network failed and lost their routing tables.
- Neighboring routers do not detect a link flap

Because the interfaces remain up during a switchover, neighboring routers do not detect a link flap (the link does not go down and come back up).
- Prevents routing flaps

Because SSO continues forwarding network traffic during a switchover, routing flaps are avoided.
- Maintains user sessions established prior to the switchover

Catalyst 4500 series switches also support route processor redundancy (RPR). For information about these redundancy modes, see [Chapter 8, “Configuring Supervisor Engine Redundancy Using RPR and SSO.”](#)

SSO Operation

SSO establishes one of the supervisor engines as active while the other supervisor engine is designated as standby, and then SSO synchronizes information between them. A switchover from the active to the redundant supervisor engine occurs when the active supervisor engine fails, or is removed from the switch, or is manually shut down for maintenance.

In networking devices running SSO, both supervisor engines must be running the same Cisco IOS software version and ROMMON version so that the redundant supervisor engine is always ready to assume control following a fault on the active supervisor engine. SSO switchover also preserves FIB and adjacency entries and can forward Layer 3 traffic after a switchover. Configuration information and data structures are synchronized from the active to the redundant supervisor engine at startup and whenever changes to the active supervisor engine configuration occur. Following an initial synchronization between the two supervisor engines, SSO maintains state information between them, including forwarding information.

During switchover, system control and routing protocol execution is transferred from the active supervisor engine to the redundant supervisor engine.



Note

Be aware that you can use the **[no] service slave-log** configuration command to forward all error messages from the standby supervisor engine to the active engine. By default, this capability is enabled. For details, refer to the *Catalyst 4500 Series Switch Cisco IOS System Error Message Guide*, Release 12.2(37)SG.

NSF Operation

NSF always runs with SSO and provides redundancy for Layer 3 traffic. NSF is supported by the BGP, OSPF, IS-IS, and EIGRP routing protocols and is supported by Cisco Express Forwarding (CEF) for forwarding. The routing protocols have been enhanced with NSF-capability and awareness, which means that routers running these protocols can detect a switchover and take the necessary actions to continue forwarding network traffic and to recover route information from the peer devices. The IS-IS protocol can be configured to use state information that has been synchronized between the active and the redundant supervisor engine to recover route information following a switchover instead of information received from peer devices.

A networking device is NSF-aware if it is running NSF-compatible software. A device is NSF-capable if it has been configured to support NSF; it rebuilds routing information from NSF-aware or NSF-capable neighbors.

Each protocol depends on CEF to continue forwarding packets during switchover while the routing protocols rebuild the Routing Information Base (RIB) tables. After the routing protocols have converged, CEF updates the FIB table and removes stale route entries. CEF then updates the line cards with the new FIB information.

Cisco Express Forwarding

A key element of NSF is packet forwarding. In a Cisco networking device, packet forwarding is provided by Cisco Express Forwarding (CEF). CEF maintains the FIB and uses the FIB information that was current at the time of the switchover to continue forwarding packets during a switchover. This feature reduces traffic interruption during the switchover.

During normal NSF operation, CEF on the active supervisor engine synchronizes its current FIB and adjacency databases with the FIB and adjacency databases on the redundant supervisor engine. Upon switchover of the active supervisor engine, the redundant supervisor engine initially has FIB and adjacency databases that are mirror images of those that were current on the active supervisor engine. For platforms with forwarding engines, CEF keeps the forwarding engine on the redundant supervisor engine current with changes that are sent to it by CEF on the active supervisor engine. The forwarding engine can continue forwarding after a switchover as soon as the interfaces and a data path are available.

As the routing protocols start to repopulate the RIB on a prefix-by-prefix basis, the updates cause prefix-by-prefix updates to CEF, which it uses to update the FIB and adjacency databases. Existing and new entries receive the new version (“epoch”) number, indicating that they have been refreshed. The forwarding information is updated on the forwarding engine during convergence. The supervisor engine signals when the RIB has converged. The software removes all FIB and adjacency entries that have an epoch older than the current switchover epoch. The FIB now represents the newest routing protocol forwarding information.

Routing Protocols



Note

Use of the routing protocols require the Enterprise Services Cisco IOS Software image for the Catalyst 4500 series switch.

The routing protocols run only on the active supervisor engine, and they receive routing updates from their neighbor routers. Routing protocols do not run on the standby supervisor engine. Following a switchover, the routing protocols request that the NSF-aware neighbor devices send state information to

help rebuild the routing tables. Alternately, the IS-IS protocol can be configured to synchronize state information from the active to the redundant supervisor engine to help rebuild the routing table on the NSF-capable device in environments where neighbor devices are not NSF-aware. NSF supports the BGP, OSPF, IS-IS, and EIGRP protocols.

**Note**

For NSF operation, the routing protocols depend on CEF to continue forwarding packets while the routing protocols rebuild the routing information.

BGP Operation

When an NSF-capable router begins a BGP session with a BGP peer, it sends an OPEN message to the peer. Included in the message is a statement that the NSF-capable device has “graceful” restart capability. Graceful restart is the mechanism by which BGP routing peers avoid a routing flap following a switchover. If the BGP peer has received this capability, it is aware that the device sending the message is NSF-capable. Both the NSF-capable router and its BGP peers need to exchange the graceful restart capability in their OPEN messages at the time of session establishment. If both the peers do not exchange the graceful restart capability, the session will not be capable of a graceful restart.

If the BGP session is lost during the supervisor engine switchover, the NSF-aware BGP peer marks all the routes associated with the NSF-capable router as stale; however, it continues to use these routes to make forwarding decisions for a set period of time. This functionality prevents packets from being lost while the newly active supervisor engine is waiting for convergence of the routing information with the BGP peers.

After a supervisor engine switchover occurs, the NSF-capable router reestablishes the session with the BGP peer. In establishing the new session, it sends a new graceful restart message that identifies the NSF-capable router as having restarted.

At this point, the routing information is exchanged between the two BGP peers. After this exchange is complete, the NSF-capable device uses the routing information to update the RIB and the FIB with the new forwarding information. The NSF-aware device uses the network information to remove stale routes from its BGP table; the BGP protocol then is fully converged.

If a BGP peer does not support the graceful restart capability, it ignores the graceful restart capability in an OPEN message but establishes a BGP session with the NSF-capable device. This function allows interoperability with non-NSF-aware BGP peers (and without NSF functionality), but the BGP session with non-NSF-aware BGP peers is not capable of a graceful restart.

**Note**

BGP support in NSF requires that neighbor networking devices be NSF-aware; that is, the devices must have the graceful restart capability and advertise that capability in their OPEN message during session establishment. If an NSF-capable router discovers that a particular BGP neighbor does not have graceful restart capability, it does not establish an NSF-capable session with that neighbor. All other neighbors that have graceful restart capability continue to have NSF-capable sessions with this NSF-capable networking device.

OSPF Operation

When an OSPF NSF-capable router performs a supervisor engine switchover, it must perform the following tasks in order to resynchronize its link state database with its OSPF neighbors:

- Relearn the available OSPF neighbors on the network without causing a reset of the neighbor relationship

- Reacquire the contents of the link state database for the network

As quickly as possible after a supervisor engine switchover, the NSF-capable router sends an OSPF NSF signal to neighboring NSF-aware devices. Neighbor networking devices recognize this signal as an indicator that the neighbor relationship with this router should not be reset. As the NSF-capable router receives signals from other routers on the network, it can begin to rebuild its neighbor list.

After neighbor relationships are reestablished, the NSF-capable router begins to resynchronize its database with all of its NSF-aware neighbors. At this point, the routing information is exchanged between the OSPF neighbors. Once this exchange is complete, the NSF-capable device uses the routing information to remove stale routes, update the RIB, and update the FIB with the new forwarding information. The OSPF protocols are then fully converged.

**Note**

OSPF support in NSF requires that all neighbor networking devices be NSF-aware. If an NSF-capable router discovers that it has non-NSF-aware neighbors on a particular network segment, it disables NSF capabilities for that segment. Other network segments composed entirely of NSF-capable or NSF-aware routers continue to provide NSF capabilities.

IS-IS Operation

When an IS-IS NSF-capable router performs a supervisor engine switchover, it must perform the following tasks in order to resynchronize its link state database with its IS-IS neighbors:

- Relearn the available IS-IS neighbors on the network without causing a reset of the neighbor relationship
- Reacquire the contents of the link state database for the network

The IS-IS NSF feature offers two options when you configure NSF:

- Internet Engineering Task Force (IETF) IS-IS
- Cisco IS-IS

If neighbor routers on a network segment are running a software version that supports the IETF Internet draft for router restartability, they assist an IETF NSF router that is restarting. With IETF, neighbor routers provide adjacency and link-state information to help rebuild the routing information following a switchover. A benefit of IETF IS-IS configuration is operation between peer devices based on a proposed standard.

**Note**

If you configure IETF on the networking device, but neighbor routers are not IETF-compatible, NSF aborts following a switchover.

If the neighbor routers on a network segment are not NSF-aware, you must use the Cisco configuration option. The Cisco IS-IS configuration transfers both protocol adjacency and link-state information from the active to the redundant supervisor engine. An advantage of Cisco configuration is that it does not rely on NSF-aware neighbors.

IETF IS-IS Configuration

As quickly as possible after a supervisor engine switchover, the NSF-capable router sends IS-IS NSF restart requests to neighboring NSF-aware devices using the IETF IS-IS configuration. Neighbor networking devices recognize this restart request as an indicator that the neighbor relationship with this

router should not be reset, but that they should initiate database resynchronization with the restarting router. As the restarting router receives restart request responses from routers on the network, it can begin to rebuild its neighbor list.

After this exchange is complete, the NSF-capable device uses the link-state information to remove stale routes, update the RIB, and update the FIB with the new forwarding information; IS-IS is then fully converged.

The switchover from one supervisor engine to the other happens within seconds. IS-IS reestablishes its routing table and resynchronizes with the network within a few additional seconds. At this point, IS-IS waits for a specified interval before it attempts a second NSF restart. During this time, the new redundant supervisor engine boots up and synchronizes its configuration with the active supervisor engine. The IS-IS NSF operation waits for a specified interval to ensure that connections are stable before attempting another restart of IS-IS NSF. This functionality prevents IS-IS from attempting back-to-back NSF restarts with stale information.

Cisco IS-IS Configuration

Using the Cisco configuration option, full adjacency and LSP information is saved, or *checkpointed*, to the redundant supervisor engine. Following a switchover, the newly active supervisor engine maintains its adjacencies using the check-pointed data, and can quickly rebuild its routing tables.



Note

Following a switchover, Cisco IS-IS NSF has complete neighbor adjacency and LSP information; however, it must wait for all interfaces to come on line that had adjacencies prior to the switchover. If an interface does not come on line within the allocated interface wait time, the routes learned from these neighbor devices are not considered in routing table recalculation. IS-IS NSF provides a command to extend the wait time for interfaces that, for whatever reason, do not come on line in a timely fashion.

The switchover from one supervisor engine to the other happens within seconds. IS-IS reestablishes its routing table and resynchronizes with the network within a few additional seconds. At this point, IS-IS waits for a specified interval before it attempts a second NSF restart. During this time, the new redundant supervisor engine boots up and synchronizes its configuration with the active supervisor engine. After this synchronization is completed, IS-IS adjacency and LSP data is check-pointed to the redundant supervisor engine; however, a new NSF restart is not attempted by IS-IS until the interval time expires. This functionality prevents IS-IS from attempting back-to-back NSF restarts.

EIGRP Operation

When an EIGRP NSF-capable router initially re-boots after an NSF restart, it has no neighbor and its topology table is empty. The router is notified by the redundant (now active) supervisor engine when it needs to bring up the interfaces, reacquire neighbors, and rebuild the topology and routing tables. The restarting router and its peers must accomplish these tasks without interrupting the data traffic directed toward the restarting router. EIGRP peer routers maintain the routes learned from the restarting router and continue forwarding traffic through the NSF restart process.

To prevent an adjacency reset by the neighbors, the restarting router uses a new Restart (RS) bit in the EIGRP packet header to indicate a restart. The RS bit is set in the hello packets and in the initial INIT update packets during the NSF restart period. The RS bit in the hello packets allows the neighbors to be quickly notified of the NSF restart. Without seeing the RS bit, the neighbor can only detect an adjacency reset by receiving an INIT update or by the expiration of the hello hold timer. Without the RS bit, a neighbor does not know if the adjacency reset should be handled using NSF or the normal startup method.

When the neighbor receives the restart indication, either by receiving the hello packet or the INIT packet, it recognizes the restarting peer in its peer list and maintains the adjacency with the restarting router. The neighbor then sends it topology table to the restarting router with the RS bit set in the first update packet indicating that it is NSF-aware and is helping out the restarting router. The neighbor does not set the RS bit in their hello packets, unless it is also a NSF restarting neighbor.

**Note**

A router may be NSF-aware but may not be helping the NSF restarting neighbor because booting from a cold start.

If at least one of the peer routers is NSF-aware, the restarting router would then receive updates and rebuild its database. The restarting router must then find out if it had converged so that it can notify the routing information base (RIB). Each NSF-aware router is required to send an end of table (EOT) marker in the last update packet to indicate the end of the table content. The restarting router knows it has converged when it receives the EOT marker. The restarting router can then begin sending updates.

An NSF-aware peer would know when the restarting router had converged when it receives an EOT indication from the restarting router. The peer then scans its topology table to search for the routes with the restarted neighbor as the source. The peer compares the route timestamp with the restart event timestamp to determine if the route is still available. The peer then goes active to find alternate paths for the routes that are no longer available through the restarted router.

When the restarting router has received all EOT indications from its neighbors or when the NSF converge timer expires, EIGRP notifies the RIB of convergence. EIGRP waits for the RIB convergence signal and then floods its topology table to all awaiting NSF-aware peers.

NSF Guidelines and Restrictions

NSF with SSO has these restrictions:

- For NSF operation, you must have SSO configured on the device.
- NSF with SSO supports IP Version 4 traffic and protocols only; NSF with SSO does not support IPv6 traffic.
- The Virtual Redundancy Routing Protocols (VRRP) is not SSO-aware, meaning state information is not maintained between the active and standby supervisor engine during normal operation. VRRP and SSO can coexist but both features work independently. Traffic that relies on VRRP may switch to the VRRP standby in the event of a supervisor switchover.
- All neighboring devices participating in BGP NSF must be NSF-capable and configured for BGP graceful restart.
- OSPF NSF for virtual links is not supported.
- All OSPF networking devices on the same network segment must be NSF-aware (running an NSF software image).
- For IETF IS-IS, all neighboring devices must be running an NSF-aware software image.

Configuring NSF with SSO Supervisor Engine Redundancy

The following sections describe the configuration tasks for the NSF feature:

- [Configuring SSO, page 9-10](#)

- [Configuring CEF NSF, page 9-11](#)
- [Verifying CEF NSF, page 9-11](#)
- [Configuring BGP NSF, page 9-11](#)
- [Verifying BGP NSF, page 9-12](#)
- [Configuring OSPF NSF, page 9-13](#)
- [Verifying OSPF NSF, page 9-13](#)
- [Configuring IS-IS NSF, page 9-14](#)
- [Verifying IS-IS NSF, page 9-15](#)
- [Configuring EIGRP NSF, page 9-16](#)
- [Verifying EIGRP NSF, page 9-17](#)

Configuring SSO

You must configure SSO in order to use NSF with any supported protocol. To configure SSO, perform this task:

	Command	Purpose
Step 1	Switch(config)# redundancy	Enters redundancy configuration mode.
Step 2	Switch(config-red)# mode sso	Configures SSO. When this command is entered, the redundant supervisor engine is reloaded and begins to work in SSO mode.
Step 3	Switch(config-red)# end	Returns to EXEC mode.
Step 4	Switch# show running-config	Verifies that SSO is enabled.
Step 5	Switch# show redundancy states	Displays the operating redundancy mode.



Note

The **sso** keyword is supported in Cisco IOS Release 12.2(20)EWA and later releases.

This example shows how to configure the system for SSO and display the redundancy state:

```
Switch> enable
Switch# configure terminal
Enter configuration commands, one per line. End with CNTL/Z.
Switch(config)# redundancy
Switch(config-red)# mode sso
Switch(config-red)# end
Switch# show redundancy states
my state = 13 -ACTIVE
    peer state = 8 -STANDBY HOT
        Mode = Duplex
        Unit = Primary
        Unit ID = 5

Redundancy Mode (Operational) = sso
Redundancy Mode (Configured) = sso
    Split Mode = Disabled
    Manual Swact = Enabled
    Communications = Up
```

```

client count = 29
client_notification_TMR = 30000 milliseconds
  keep_alive TMR = 9000 milliseconds
  keep_alive count = 1
  keep_alive threshold = 18
  RF debug mask = 0x0
Switch#

```

Configuring CEF NSF

The CEF NSF feature operates by default while the networking device is running in SSO mode. No configuration is necessary.

Verifying CEF NSF

To verify that CEF is NSF-capable, enter the **show cef state** command:

```

Switch# show cef state

CEF Status [RP]
CEF enabled/running
dCEF enabled/running
CEF switching enabled/running
CEF default capabilities:
Always FIB switching:      yes
Default CEF switching:    yes
Default dCEF switching:   yes
Update HWIDB counters:    no
Drop multicast packets:   no
.
.
.
CEF NSF capable:          yes
IPC delayed func on SSO:  no
RRP state:
I am standby RRP:        no
My logical slot:          0
RF PeerComm:              no

```

Configuring BGP NSF



Note

You must configure BGP graceful restart on all peer devices participating in BGP NSF.

To configure BGP for NSF, perform this task (repeat this procedure on each of the BGP NSF peer devices):

	Command	Purpose
Step 1	Switch# configure terminal	Enters global configuration mode.

	Command	Purpose
Step 2	Switch(config)# router bgp <i>as-number</i>	Enables a BGP routing process, which places the switch in switch configuration mode.
Step 3	Switch(config-router)# bgp graceful-restart	Enables the BGP graceful restart capability, starting BGP NSF. If you enter this command after the BGP session has been established, you must restart the session for the capability to be exchanged with the BGP neighbor. Use this command on the restarting switch and all of its peers.

Verifying BGP NSF

To verify BGP NSF, you must check that BGP graceful restart is configured on the SSO-enabled networking device and on the neighbor devices. To verify, follow these steps:

- Step 1** Verify that “bgp graceful-restart” appears in the BGP configuration of the SSO-enabled switch by entering the **show running-config** command:

```
Switch# show running-config
.
.
.
router bgp 120
.
.
.
bgp graceful-restart
  neighbor 10.2.2.2 remote-as 300
.
.
.
```

- Step 2** Repeat Step 1 on each of the BGP neighbors.

- Step 3** On the SSO device and the neighbor device, verify that the graceful restart function is shown as both advertised and received, and confirm the address families that have the graceful restart capability. If no address families are listed, BGP NSF does not occur either:

```
Switch# show ip bgp neighbors x.x.x.x

BGP neighbor is 192.168.2.2, remote AS YY, external link
  BGP version 4, remote router ID 192.168.2.2
  BGP state = Established, up for 00:01:18
  Last read 00:00:17, hold time is 180, keepalive interval is 60 seconds
  Neighbor capabilities:
    Route refresh:advertised and received(new)
    Address family IPv4 Unicast:advertised and received
    Address family IPv4 Multicast:advertised and received
    Graceful Restart Capabilty:advertised and received
      Remote Restart timer is 120 seconds
    Address families preserved by peer:
```

```

IPv4 Unicast, IPv4 Multicast
Received 1539 messages, 0 notifications, 0 in queue
Sent 1544 messages, 0 notifications, 0 in queue
Default minimum time between advertisement runs is 30 seconds

```

Configuring OSPF NSF



Note

All peer devices participating in OSPF NSF must be made OSPF NSF-aware, which happens automatically when you install an NSF software image on the device.

To configure OSPF NSF, perform this task:

	Command	Purpose
Step 1	Switch# configure terminal	Enters global configuration mode.
Step 2	Switch(config)# router ospf processID	Enables an OSPF routing process, which places the switch in router configuration mode.
Step 3	Switch(config-router)# nsf	Enables NSF operations for OSPF.

Verifying OSPF NSF

To verify OSPF NSF, you must check that the NSF function is configured on the SSO-enabled networking device. To verify OSPF NSF, follow these steps:

- Step 1** Verify that 'nsf' appears in the OSPF configuration of the SSO-enabled device by entering the **show running-config** command:

```

Switch# show running-config

route ospf 120
log-adjacency-changes
nsf
network 192.168.20.0 0.0.0.255 area 0
network 192.168.30.0 0.0.0.255 area 1
network 192.168.40.0 0.0.0.255 area 2
.
.
.

```

- Step 2** Enter the **show ip ospf** command to verify that NSF is enabled on the device:

```

Switch> show ip ospf

Routing Process "ospf 1" with ID 192.168.2.1 and Domain ID 0.0.0.1
Supports only single TOS(TOS0) routes
Supports opaque LSA
SPF schedule delay 5 secs, Hold time between two SPFs 10 secs
Minimum LSA interval 5 secs. Minimum LSA arrival 1 secs
Number of external LSA 0. Checksum Sum 0x0

```

```

Number of opaque AS LSA 0. Checksum Sum 0x0
Number of DCbitless external and opaque AS LSA 0
Number of DoNotAge external and opaque AS LSA 0
Number of areas in this router is 1. 1 normal 0 stub 0 nssa
External flood list length 0
Non-Stop Forwarding enabled, last NSF restart 00:02:06 ago (took 44 secs)
Area BACKBONE(0)
Number of interfaces in this area is 1 (0 loopback)
  Area has no authentication
  SPF algorithm executed 3 times

```

Configuring IS-IS NSF

To configure IS-IS NSF, perform this task:

	Command	Purpose
Step 1	Switch# configure terminal	Enters global configuration mode.
Step 2	Switch(config)# router isis [<i>tag</i>]	Enables an IS-IS routing process, which places the switch in router configuration mode.
Step 3	Switch(config-router)# nsf [cisco ietf]	Enables NSF operation for IS-IS. Enter the ietf keyword to enable IS-IS in a homogeneous network where adjacencies with networking devices supporting IETF draft-based restartability is guaranteed. Enter the cisco keyword to run IS-IS in heterogeneous networks that might not have adjacencies with NSF-aware networking devices.
Step 4	Switch(config-router)# nsf interval [<i>minutes</i>]	(Optional) Specifies the minimum time between NSF restart attempts. The default time between <i>consecutive</i> NSF restart attempts is 5 minutes.
Step 5	Switch(config-router)# nsf t3 { manual [<i>seconds</i>] adjacency }	(Optional) Specifies the time IS-IS waits for the IS-IS database to synchronize before generating overloaded link-state information for itself and flooding that information out to its neighbors. The t3 keyword applies only if you selected IETF operation. When you specify adjacency , the switch that is restarting obtains its wait time from neighboring devices.
Step 6	Switch(config-router)# nsf interface wait <i>seconds</i>	(Optional) Specifies how long an IS-IS NSF restart waits for all interfaces with IS-IS adjacencies to come up before completing the restart. The default is 10 seconds.

Verifying IS-IS NSF

To verify IS-IS NSF, you must check that the NSF function is configured on the SSO-enabled networking device. To verify IS-IS NSF, follow these steps:

- Step 1** Verify that “nsf” appears in the IS-IS configuration of the SSO-enabled device by entering the **show running-config** command. The display shows either the Cisco IS-IS or the IETF IS-IS configuration. The following display indicates that the device uses the Cisco implementation of IS-IS NSF:

```
Switch# show running-config
<...Output Truncated...>
router isis
nsf cisco
<...Output Truncated...>
```

- Step 2** If the NSF configuration is set to **cisco**, enter the **show isis nsf** command to verify that NSF is enabled on the device. Using the Cisco configuration, the display output differs on the active and redundant RPs. The following display shows sample output for the Cisco configuration on the active RP. In this example, note the presence of “NSF restart enabled”:

```
Switch# show isis nsf

NSF is ENABLED, mode 'cisco'

RP is ACTIVE, standby ready, bulk sync complete
NSF interval timer expired (NSF restart enabled)
Checkpointing enabled, no errors
Local state:ACTIVE, Peer state:STANDBY HOT, Mode:SSO
```

The following display shows sample output for the Cisco configuration on the standby RP. In this example, note the presence of “NSF restart enabled”:

```
Switch# show isis nsf

NSF enabled, mode 'cisco'
RP is STANDBY, chkpt msg receive count:ADJ 2, LSP 7
NSF interval timer notification received (NSF restart enabled)
Checkpointing enabled, no errors
Local state:STANDBY HOT, Peer state:ACTIVE, Mode:SSO
```

- Step 3** If the NSF configuration is set to **ietf**, enter the **show isis nsf** command to verify that NSF is enabled on the device. The following display shows sample output for the IETF IS-IS configuration on the networking device:

```
Switch# show isis nsf

NSF is ENABLED, mode IETF
NSF pdb state:Inactive
NSF L1 active interfaces:0
NSF L1 active LSPs:0
NSF interfaces awaiting L1 CSNP:0
Awaiting L1 LSPs:
NSF L2 active interfaces:0
NSF L2 active LSPs:0
NSF interfaces awaiting L2 CSNP:0
Awaiting L2 LSPs:
```

```

Interface:Serial3/0/2
  NSF L1 Restart state:Running
  NSF p2p Restart retransmissions:0
  Maximum L1 NSF Restart retransmissions:3
  L1 NSF ACK requested:FALSE
  L1 NSF CSNP requested:FALSE
  NSF L2 Restart state:Running
  NSF p2p Restart retransmissions:0
  Maximum L2 NSF Restart retransmissions:3
  L2 NSF ACK requested:FALSE
Interface:GigabitEthernet2/0/0
  NSF L1 Restart state:Running
  NSF L1 Restart retransmissions:0
  Maximum L1 NSF Restart retransmissions:3
  L1 NSF ACK requested:FALSE
  L1 NSF CSNP requested:FALSE
  NSF L2 Restart state:Running
  NSF L2 Restart retransmissions:0
  Maximum L2 NSF Restart retransmissions:3
  L2 NSF ACK requested:FALSE
  L2 NSF CSNP requested:FALSE
Interface:Loopback1
  NSF L1 Restart state:Running
  NSF L1 Restart retransmissions:0
  Maximum L1 NSF Restart retransmissions:3
  L1 NSF ACK requested:FALSE
  L1 NSF CSNP requested:FALSE
  NSF L2 Restart state:Running
  NSF L2 Restart retransmissions:0
  Maximum L2 NSF Restart retransmissions:3
  L2 NSF ACK requested:FALSE
  L2 NSF CSNP requested:FALSE

```

Configuring EIGRP NSF

To configure EIGRP NSF, perform this task:

	Command	Purpose
Step 1	Switch# configure terminal	Enters global configuration mode.
Step 2	Switch(config)# router eigrp <i>as-number</i>	Enables an EIGRP routing process, which places the switch in router configuration mode.
Step 3	Switch(config-router)# nsf	Enables EIGRP NSF. Use this command on the “restarting” switch and all of its peers.

Verifying EIGRP NSF

To verify EIGRP NSF, you must check that the NSF function is configured on the SSO-enabled networking device. To verify EIGRP NSF, follow these steps:

- Step 1** Verify that “nsf” appears in the EIGRP configuration of the SSO-enabled device by entering the **show running-config** command:

```
Switch# show running-config
.
.
.
router eigrp 100
  auto-summary
  nsf
.
.
```

- Step 2** Enter the **show ip protocols** command to verify that NSF is enabled on the device:

```
Switch# show ip protocols
*** IP Routing is NSF aware ***
Routing Protocol is "eigrp 100"
  Outgoing update filter list for all interfaces is not set
  Incoming update filter list for all interfaces is not set
  Default networks flagged in outgoing updates
  Default networks accepted from incoming updates
  EIGRP metric weight K1=1, K2=0, K3=1, K4=0, K5=0
  EIGRP maximum hopcount 100
  EIGRP maximum metric variance 1
  Redistributing: eigrp 100
  EIGRP NSF-aware route hold timer is 240s
  EIGRP NSF enabled
    NSF signal timer is 20s
    NSF converge timer is 120s
  Automatic network summarization is in effect
  Maximum path: 4
  Routing for Networks:
  Routing Information Sources:
    Gateway         Distance         Last Update
  Distance: internal 90 external 170
```

