

Configuring EtherChannel

This chapter describes how to use the command-line interface (CLI) to configure EtherChannel on the Catalyst 4500 series switch Layer 2 or Layer 3 interfaces. It also provides guidelines, procedures, and configuration examples.

This chapter includes the following major sections:

- [EtherChannel Overview, page 21-1](#)
- [EtherChannel Configuration Guidelines and Restrictions, page 21-5](#)
- [Configuring EtherChannel, page 21-6](#)
- [Displaying EtherChannel to a Virtual Switch System, page 21-15](#)

**Note**

The commands in the following sections can be used on all Ethernet interfaces on a Catalyst 4500 series switch, including the uplink ports on the supervisor engine.

**Note**

For complete syntax and usage information for the switch commands used in this chapter, first look at the *Cisco Catalyst 4500 Series Switch Command Reference* and related publications at this location:

<http://www.cisco.com/en/US/products/hw/switches/ps4324/index.html>

If the command is not found in the Catalyst 4500 Command Reference, it will be found in the larger Cisco IOS library. Refer to the *Cisco IOS Command Reference* and related publications at this location:

<http://www.cisco.com/en/US/products/ps6350/index.html>

EtherChannel Overview

EtherChannel bundles individual Ethernet links into a single logical link that provides bandwidth up to 1600 Mbps (Fast EtherChannel full duplex), 16 Gbps (Gigabit EtherChannel), or 40 Gbps (10 Gigabit Etherchannel) between a Catalyst 4500 series switch and another switch or host.

A Catalyst 4500 series switch supports a maximum of 64 EtherChannels. You can form an EtherChannel with up to eight compatibly configured Ethernet interfaces across modules in a Catalyst 4500 series switch. All interfaces in each EtherChannel must be the same speed and must be configured as either Layer 2 or Layer 3 interfaces.

**Note**

The network device to which a Catalyst 4500 series switch is connected may impose its own limits on the number of interfaces in an EtherChannel.

If a segment within an EtherChannel fails, traffic previously carried over the failed link switches to the remaining segments within the EtherChannel. When the segment fails, an SNMP trap is sent, identifying the switch, the EtherChannel, and the failed link. Inbound broadcast and multicast packets on one segment in an EtherChannel are blocked from returning on any other segment of the EtherChannel.

**Note**

The port channel link failure switchover for the Catalyst 4500 series switch was measured at 50 ms, giving you SONET-like link failure switchover time.

These subsections describe how EtherChannel works:

- [Port-Channel Interfaces, page 21-2](#)
- [How EtherChannels Are Configured, page 21-2](#)
- [Load Balancing, page 21-5](#)

Port-Channel Interfaces

Each EtherChannel has a numbered port-channel interface. A configuration applied to the port-channel interface affects all physical interfaces assigned to that interface.

**Note**

QoS does not propagate to members. The defaults, QoS cos = 0 and QoS dscp = 0, apply on the portchannel. Input or output policies applied on individual interfaces are ignored.

After you configure an EtherChannel, the configuration that you apply to the port-channel interface affects the EtherChannel; the configuration that you apply to the physical interfaces affects only the interface where you apply the configuration. To change the parameters of all ports in an EtherChannel, apply configuration commands to the port-channel interface (such commands can be STP commands or commands to configure a Layer 2 EtherChannel as a trunk).

How EtherChannels Are Configured

These subsections describe how EtherChannels are configured:

- [EtherChannel Configuration Overview, page 21-3](#)
- [Manual EtherChannel Configuration, page 21-3](#)
- [PAgP EtherChannel Configuration, page 21-3](#)
- [IEEE 802.3ad LACP EtherChannel Configuration, page 21-4](#)

EtherChannel Configuration Overview

You can configure EtherChannels manually or you can use the Port Aggregation Control Protocol (PAgP) or, with Cisco IOS Release 12.2(25)EWA and later, the Link Aggregation Control Protocol (LACP) to form EtherChannels. The EtherChannel protocols allow ports with similar characteristics to form an EtherChannel through dynamic negotiation with connected network devices. PAgP is a Cisco-proprietary protocol and LACP is defined in IEEE 802.3ad.

PAgP and LACP do not interoperate. Ports configured to use PAgP cannot form EtherChannels with ports configured to use LACP and vice versa.

Table 21-1 lists the user-configurable EtherChannel modes.

Table 21-1 EtherChannel Modes

| Mode | Description |
|------------------|--|
| on | Mode that forces the LAN port to channel unconditionally. In the on mode, a usable EtherChannel exists only when a LAN port group in the on mode is connected to another LAN port group in the on mode. Because ports configured in the on mode do not negotiate, there is no negotiation traffic between the ports. |
| auto | PAgP mode that places a LAN port into a passive negotiating state in which the port responds to PAgP packets it receives but does not initiate PAgP negotiation. |
| desirable | PAgP mode that places a LAN port into an active negotiating state in which the port initiates negotiations with other LAN ports by sending PAgP packets. |
| passive | LACP mode that places a port into a passive negotiating state in which the port responds to LACP packets it receives but does not initiate LACP negotiation. |
| active | LACP mode that places a port into an active negotiating state in which the port initiates negotiations with other ports by sending LACP packets. |

Manual EtherChannel Configuration

Manually configured EtherChannel ports do not exchange EtherChannel protocol packets. A manually configured EtherChannel forms only when you configure all ports in the EtherChannel compatibly.

PAgP EtherChannel Configuration

PAgP supports the automatic creation of EtherChannels by exchanging PAgP packets between LAN ports. PAgP packets are exchanged only between ports in **auto** and **desirable** modes.

The protocol learns the capabilities of LAN port groups dynamically and informs the other LAN ports. Once PAgP identifies correctly matched Ethernet links, it facilitates grouping the links into an EtherChannel. The EtherChannel is then added to the spanning tree as a single bridge port.

Both the **auto** and **desirable** modes allow PAgP to negotiate between LAN ports to determine if they can form an EtherChannel, based on criteria such as port speed and trunking state. Layer 2 EtherChannels also use VLAN numbers.

LAN ports can form an EtherChannel when they are in different PAgP modes if the modes are compatible. For example:

- A LAN port in **desirable** mode can form an EtherChannel successfully with another LAN port that is in **desirable** mode.
- A LAN port in **desirable** mode can form an EtherChannel with another LAN port in **auto** mode.

- A LAN port in **auto** mode cannot form an EtherChannel with another LAN port that is also in **auto** mode because neither port initiates negotiation.

IEEE 802.3ad LACP EtherChannel Configuration

Cisco IOS Release 12.2(25)EWA and later releases support IEEE 802.3ad LACP EtherChannels. LACP supports the automatic creation of EtherChannels by exchanging LACP packets between LAN ports. LACP packets are exchanged only between ports in **passive** and **active** modes.

The protocol learns the capabilities of LAN port groups dynamically and informs the other LAN ports. Once LACP identifies correctly matched Ethernet links, it facilitates grouping the links into an EtherChannel. The EtherChannel is then added to the spanning tree as a single bridge port.

Both the **passive** and **active** modes allow LACP to negotiate between LAN ports to determine if they can form an EtherChannel, based on criteria such as port speed and trunking state. Layer 2 EtherChannels also use VLAN numbers.

LAN ports can form an EtherChannel when they are in different LACP modes as long as the modes are compatible. For example:

- A LAN port in **active** mode can form an EtherChannel successfully with another LAN port that is in **active** mode.
- A LAN port in **active** mode can form an EtherChannel with another LAN port in **passive** mode.
- A LAN port in **passive** mode cannot form an EtherChannel with another LAN port that is also in **passive** mode, because neither port initiates negotiation.

LACP uses the following parameters:

- LACP system priority—You may configure an LACP system priority on each switch running LACP. The system priority can be configured automatically or through the CLI. See the [“Configuring the LACP System Priority and System ID” section on page 21-12](#). LACP uses the system priority with the switch MAC address to form the system ID and also during negotiation with other systems.



Note The LACP system ID is the combination of the LACP system priority value and the MAC address of the switch.

- LACP port priority—You must configure an LACP port priority on each port configured to use LACP. The port priority can be configured automatically or through the CLI. See the [“Configuring Layer 2 EtherChannels” section on page 21-9](#). LACP uses the port priority with the port number to form the port identifier.
- LACP administrative key—LACP automatically configures an administrative key value equal to the channel group identification number on each port configured to use LACP. The administrative key defines the ability of a port to aggregate with other ports. A port’s ability to aggregate with other ports is determined by these factors:
 - Port physical characteristics, such as data rate, duplex capability, and point-to-point or shared medium
 - Configuration restrictions that you establish

LACP tries to configure the maximum number of compatible ports in an EtherChannel up to the maximum allowed by the hardware (eight ports). If a port cannot be actively included in a channel, it is not included automatically if a channelled port fails.

**Note**

Standby and “sub-channeling” are not supported in LACP and PAgP.

Load Balancing

EtherChannel can balance the traffic load across the links in the channel by reducing part of the binary pattern formed from the addresses or ports in the frame to a numerical value that selects one of the links in the channel. To balance the load, EtherChannel uses MAC addresses, IP addresses, or Layer 4 port numbers, and either the message source or message destination, or both.

Use the option that provides the greatest variety in your configuration. For example, if the traffic on a channel is going only to a single MAC address, using the destination MAC address always chooses the same link in the channel; using source addresses or IP addresses might result in better load balancing.

**Note**

Load balancing can only be configured globally. As a result, all channels (manually configured, PAgP, or LACP) use the same load balancing method.

For additional information on load balancing, see the [“Configuring EtherChannel Load Balancing” section on page 21-13](#).

EtherChannel Configuration Guidelines and Restrictions

If improperly configured, some EtherChannel interfaces are disabled automatically to avoid network loops and other problems. Follow these guidelines and restrictions to avoid configuration problems:

- All Ethernet interfaces on all modules support EtherChannel (maximum of eight interfaces) with no requirement that interfaces be physically contiguous or on the same module.
- Configure all interfaces in an EtherChannel to operate at the same speed and duplex mode.
- Enable all interfaces in an EtherChannel. Putting down an interface in an Ether Channel is treated as a link failure, and its traffic is transferred to one of the remaining interfaces in the EtherChannel.
- An EtherChannel does not form if one of the interfaces is a Switched Port Analyzer (SPAN) destination port.
- For Layer 3 EtherChannels:
 - Assign Layer 3 addresses to the port-channel logical interface, not to the physical interfaces in the channel.
- For Layer 2 EtherChannels:
 - Assign all interfaces in the EtherChannel to the same VLAN, or configure them as trunks.
 - If you configure an EtherChannel from trunk interfaces, verify that the trunking mode and the native VLAN is the same on all the trunks. Interfaces in an EtherChannel with different trunk modes or different native VLANs can have unexpected results.
 - An EtherChannel supports the same allowed range of VLANs on all the interfaces in a trunking Layer 2 EtherChannel. If the allowed ranges differ for selected interface differ, they do not form an EtherChannel.

- Interfaces with different Spanning Tree Protocol (STP) port path costs can form an EtherChannel as long they are otherwise compatibly configured. Setting different STP port path costs does not, by itself, make interfaces incompatible for the formation of an EtherChannel.
- After you configure an EtherChannel, any configuration that you apply to the port-channel interface affects the EtherChannel; any configuration that you apply to the physical interfaces affects only the interface you configure.

Storm Control is an exception to this rule. For example, you cannot configure Storm Control on some of the members of an EtherChannel; Storm Control must be configured on all or none of the ports. If you configure Storm Control on only some of the ports, those ports will be dropped from the EtherChannel interface (put in suspended state). Therefore, you should configure Storm Control at the port-channel interface level, and not at the physical interface level.
- A physical interface with port security enabled can join a Layer 2 EtherChannel only if port security is also enabled on the EtherChannel; otherwise the command is rejected by the CLI.
- You cannot configure a 802.1X port in an EtherChannel.

Configuring EtherChannel

These sections describe how to configure EtherChannel:

- [Configuring Layer 3 EtherChannels, page 21-6](#)
- [Configuring Layer 2 EtherChannels, page 21-9](#)
- [Configuring the LACP System Priority and System ID, page 21-12](#)
- [Configuring EtherChannel Load Balancing, page 21-13](#)
- [Removing an Interface from an EtherChannel, page 21-14](#)
- [Removing an EtherChannel, page 21-14](#)



Note

Ensure that the interfaces are configured correctly. (See the “[EtherChannel Configuration Guidelines and Restrictions](#)” section on page 21-5.)

Configuring Layer 3 EtherChannels

To configure Layer 3 EtherChannels, create the port-channel logical interface and then put the Ethernet interfaces into the portchannel.

These sections describe Layer 3 EtherChannel configuration:

- [Creating Port-Channel Logical Interfaces, page 21-6](#)
- [Configuring Physical Interfaces as Layer 3 EtherChannels, page 21-7](#)

Creating Port-Channel Logical Interfaces



Note

To move an IP address from a physical interface to an EtherChannel, you must delete the IP address from the physical interface before configuring it on the port-channel interface.

To create a port-channel interface for a Layer 3 EtherChannel, perform this task:

| | Command | Purpose |
|--------|--|--|
| Step 1 | Switch(config)# interface port-channel <i>port_channel_number</i> | Creates the port-channel interface. The value for <i>port_channel_number</i> can range from 1 to 64. |
| Step 2 | Switch(config-if)# ip address <i>ip_address mask</i> | Assigns an IP address and subnet mask to the EtherChannel. |
| Step 3 | Switch(config-if)# end | Exits configuration mode. |
| Step 4 | Switch# show running-config interface port-channel <i>port_channel_number</i> | Verifies the configuration. |

This example shows how to create port-channel interface 1:

```
Switch# configure terminal
Switch(config)# interface port-channel 1
Switch(config-if)# ip address 172.32.52.10 255.255.255.0
Switch(config-if)# end
```

This example shows how to verify the configuration of port-channel interface 1:

```
Switch# show running-config interface port-channel 1
Building configuration...

Current configuration:
!
interface Port-channel1
 ip address 172.32.52.10 255.255.255.0
 no ip directed-broadcast
end

Switch#
```

Configuring Physical Interfaces as Layer 3 EtherChannels

To configure physical interfaces as Layer 3 EtherChannels, perform this task for each interface:

| | Command | Purpose |
|--------|--|--|
| Step 1 | Switch(config)# interface { fastethernet gigabitethernet tengigabitethernet } <i>slot/port</i> | Selects a physical interface to configure. |
| Step 2 | Switch(config-if)# no switchport | Makes this a Layer 3 routed port. |
| Step 3 | Switch(config-if)# no ip address | Ensures that no IP address is assigned to the physical interface. |
| Step 4 | Switch(config-if)# channel-group <i>port_channel_number</i> mode { active on auto passive desirable } | Configures the interface in a portchannel and specifies the PAgP or LACP mode. If you use PAgP, enter the keywords auto or desirable . If you use LACP, enter the keywords active or passive . |

| | Command | Purpose |
|--------|---|-----------------------------|
| Step 5 | Switch(config-if)# end | Exits configuration mode. |
| Step 6 | Switch# show running-config interface port-channel <i>port_channel_number</i> Switch# show running-config interface {fastethernet gigabitethernet tengigabitethernet} <i>slot/port</i> Switch# show interfaces {fastethernet gigabitethernet tengigabitethernet} <i>slot/port</i> etherchannel Switch# show etherchannel 1 port-channel | Verifies the configuration. |

This example shows how to configure Fast Ethernet interfaces 5/4 and 5/5 into port-channel 1 with PAgP mode **desirable**:

```
Switch# configure terminal
Switch(config)# interface range fastethernet 5/4 - 5 (Note: Space is mandatory.)
Switch(config-if)# no switchport
Switch(config-if)# no ip address
Switch(config-if)# channel-group 1 mode desirable
Switch(config-if)# end
```

**Note**

See the “[Configuring a Range of Interfaces](#)” section on page 6-4 for information about the **range** keyword.

The following two examples show how to verify the configuration of Fast Ethernet interface 5/4:

```
Switch# show running-config interface fastethernet 5/4
Building configuration...
```

```
Current configuration:
!
interface FastEthernet5/4
 no ip address
 no switchport
 no ip directed-broadcast
 channel-group 1 mode desirable
end
```

```
Switch# show interfaces fastethernet 5/4 etherchannel
Port state      = EC-Enbld Up In-Bndl Usr-Config
Channel group = 1          Mode = Desirable      Gchange = 0
Port-channel   = Po1       GC      = 0x00010001   Pseudo-port-channel = Po1
Port indx      = 0          Load = 0x55
```

```
Flags: S - Device is sending Slow hello.   C - Device is in Consistent state.
       A - Device is in Auto mode.         P - Device learns on physical port.
Timers: H - Hello timer is running.        Q - Quit timer is running.
       S - Switching timer is running.     I - Interface timer is running.
```

```
Local information:
Port      Flags State   Timers   Hello   Partner  PAgP   Learning  Group
Fa5/4    SC    U6/S7   30s     1       128     Any     55
```

Partner's information:

| Port | Partner Name | Partner Device ID | Partner Port | Age | Flags | Partner Group Cap. |
|-------|--------------|-------------------|--------------|-----|-------|--------------------|
| Fa5/4 | JAB031301 | 0050.0f10.230c | 2/45 | 1s | SAC | 2D |

Age of the port in the current state: 00h:54m:52s

Switch#

This example shows how to verify the configuration of port-channel interface 1 after the interfaces have been configured:

Switch# **show etherchannel 1 port-channel**

```

Channel-group listing:
-----
Group: 1
-----

Port-channels in the group:
-----
Port-channel: Po1
-----

Age of the Port-channel   = 01h:56m:20s
Logical slot/port        = 10/1           Number of ports = 2
GC                       = 0x00010001   HotStandBy port = null
Port state                = Port-channel L3-Ag Ag-Inuse

Ports in the Port-channel:

Index  Load  Port
-----
   1    00   Fa5/6
   0    00   Fa5/7

Time since last port bundled:   00h:23m:33s   Fa5/6

Switch#

```

Configuring Layer 2 EtherChannels

To configure Layer 2 EtherChannels, configure the Ethernet interfaces with the **channel-group** command. This creates the port-channel logical interface.



Note

Cisco IOS software creates port-channel interfaces for Layer 2 EtherChannels when you configure Layer 2 Ethernet interfaces with the **channel-group** command.

To configure Layer 2 Ethernet interfaces as Layer 2 EtherChannels, perform this task for each interface:

| | Command | Purpose |
|--------|--|--|
| Step 1 | Switch(config)# interface { fastethernet gigabitethernet tengigabitethernet } <i>slot/port</i> | Selects a physical interface to configure. |
| Step 2 | Switch(config-if)# channel-group <i>port_channel_number</i> mode { active on auto passive desirable } | Configures the interface in a portchannel and specifies the PAgP or LACP mode. If you use PAgP, enter the keywords auto or desirable . If you use LACP, enter the keywords active or passive . |
| Step 3 | Switch(config-if)# end | Exits configuration mode. |
| Step 4 | Switch# show running-config interface { fastethernet gigabitethernet } <i>slot/port</i> Switch# show interface { fastethernet gigabitethernet tengigabitethernet } <i>slot/port etherchannel</i> | Verifies the configuration. |

This example shows how to configure Fast Ethernet interfaces 5/6 and 5/7 into port-channel 2 with PAgP mode **desirable**:

```
Switch# configure terminal
Switch(config)# interface range fastethernet 5/6 - 7 (Note: Space is mandatory.)
Switch(config-if-range)# channel-group 2 mode desirable
Switch(config-if-range)# end
Switch# end
```



Note

See the “Using the Ethernet Management Port” section on page 6-6 for information about the **range** keyword.

This example shows how to verify the configuration of port-channel interface 2:

```
Switch# show running-config interface port-channel 2
Building configuration...

Current configuration:
!
interface Port-channel2
 switchport access vlan 10
 switchport mode access
end

Switch#
```

The following two examples show how to verify the configuration of Fast Ethernet interface 5/6:

```
Switch# show running-config interface fastethernet 5/6
Building configuration...

Current configuration:
!
interface FastEthernet5/6
 switchport access vlan 10
 switchport mode access
 channel-group 2 mode desirable
end
```

```

Switch# show interfaces fastethernet 5/6 etherchannel
Port state      = EC-Enbl'd Up In-Bndl Usr-Config
Channel group = 1          Mode = Desirable      Gcchange = 0
Port-channel   = Po1      GC   = 0x00010001
Port indx      = 0          Load = 0x55

Flags: S - Device is sending Slow hello.  C - Device is in Consistent state.
      A - Device is in Auto mode.         P - Device learns on physical port.
      d - PAgP is down.

Timers: H - Hello timer is running.       Q - Quit timer is running.
      S - Switching timer is running.     I - Interface timer is running.

Local information:

Port      Flags State  Timers  Hello  Partner  PAgP  Learning  Group
Fa5/6    SC   U6/S7   30s    1      128     Any    56

Partner's information:

Partner
Port      Name          Partner      Partner      Partner      Partner Group
Fa5/6    JAB031301    0050.0f10.230c  2/47        18s SAC      2F

Age of the port in the current state: 00h:10m:57s

```

This example shows how to verify the configuration of port-channel interface 2 after the interfaces have been configured:

```

Switch# show etherchannel 2 port-channel
      Port-channels in the group:
      -----

Port-channel: Po2
-----

Age of the Port-channel      = 00h:23m:33s
Logical slot/port           = 10/2          Number of ports in agport = 2
GC                           = 0x00020001    HotStandBy port = null
Port state                   = Port-channel Ag-Inuse

Ports in the Port-channel:

Index  Load  Port
-----
   1   00   Fa5/6
   0   00   Fa5/7

Time since last port bundled: 00h:23m:33s   Fa5/6

Switch#

```

Configuring the LACP System Priority and System ID

The LACP system ID is the LACP system priority value combined with the MAC address of the switch. To configure the LACP system priority and system ID, perform this task:

| | Command | Purpose |
|---------------|--|---|
| Step 1 | Switch(config)# lACP system-priority <i>priority_value</i> | (Optional for LACP) Valid values are 1 through 65535. Higher numbers have lower priority. The default is 32768. |
| | Switch(config)# no system port-priority | Reverts to the default. |
| Step 2 | Switch(config)# end | Exits configuration mode. |
| Step 3 | Switch# show lACP sys-id | Verifies the configuration. |

This example shows how to configure the LACP system priority:

```
Switch# configure terminal
Switch(config)# lACP system-priority 23456
Switch(config)# end
Switch# show module
```

```
Mod  Ports Card Type                               Model          Serial No.
----+-----+-----+-----+-----+-----+-----+-----+-----+-----+
  1     2  1000BaseX (GBIC) Supervisor(active)  WS-X4014       JAB063808YZ
  2    48  10/100BaseTX (RJ45)                WS-X4148-RJ    JAB0447072W
  3    48  10/100BaseTX (RJ45)V               WS-X4148-RJ45V JAE061704J6
  4    48  10/100BaseTX (RJ45)V               WS-X4148-RJ45V JAE061704ML

M MAC addresses                               Hw  Fw          Sw          Status
----+-----+-----+-----+-----+-----+-----+-----+-----+-----+
  1 0005.9a39.7a80 to 0005.9a39.7a81 2.1 12.1(12r)EW 12.1(13)EW(0.26) Ok
  2 0002.fd80.f530 to 0002.fd80.f55f 0.1                               Ok
  3 0009.7c45.67c0 to 0009.7c45.67ef 1.6                               Ok
  4 0009.7c45.4a80 to 0009.7c45.4aaf 1.6                               Ok
```

This example shows how to verify the configuration:

```
Switch# show lACP sys-id
23456,0050.3e8d.6400
Switch#
```

The system priority is displayed first, followed by the MAC address of the switch.

Configuring EtherChannel Load Balancing



Note Load balancing can only be configured globally. As a result, all channels (manually configured, PagP, or LACP) use the same load balancing method.

To configure EtherChannel load balancing, perform this task:

| | Command | Purpose |
|---------------|---|--|
| Step 1 | Switch(config)# [no] port-channel load-balance { src-mac dst-mac src-dst-mac src-ip dst-ip src-dst-ip src-port dst-port src-dst-port } | Configures EtherChannel load balancing. Use the no keyword to return EtherChannel load balancing to the default configuration. |
| Step 2 | Switch(config)# end | Exits configuration mode. |
| Step 3 | Switch# show etherchannel load-balance | Verifies the configuration. |

The load-balancing keywords are:

- **src-mac**—Source MAC addresses
- **dst-mac**—Destination MAC addresses
- **src-dst-mac**—Source and destination MAC addresses
- **src-ip**—Source IP addresses
- **dst-ip**—Destination IP addresses
- **src-dst-ip**—Source and destination IP addresses (Default)
- **src-port**—Source Layer 4 port
- **dst-port**—Destination Layer 4 port
- **src-dst-port**—Source and destination Layer 4 port

This example shows how to configure EtherChannel to use source and destination IP addresses:

```
Switch# configure terminal
Switch(config)# port-channel load-balance src-dst-ip
Switch(config)# end
Switch#
```

This example shows how to verify the configuration:

```
Switch# show etherchannel load-balance
EtherChannel Load-Balancing Configuration:
    src-dst-ip

EtherChannel Load-Balancing Addresses Used Per-Protocol:
Non-IP: Source XOR Destination MAC address
IPv4: Source XOR Destination IP address
IPv6: Source XOR Destination IP address
Switch#
```

Removing an Interface from an EtherChannel

To remove an Ethernet interface from an EtherChannel, perform this task:

| | Command | Purpose |
|--------|--|--|
| Step 1 | Switch(config)# interface { fastethernet gigabitethernet tengigabitethernet } <i>slot/port</i> | Selects a physical interface to configure. |
| Step 2 | Switch(config-if)# no channel-group | Removes the interface from the port-channel interface. |
| Step 3 | Switch(config-if)# end | Exits configuration mode. |
| Step 4 | Switch# show running-config interface { fastethernet gigabitethernet tengigabitethernet } <i>slot/port</i> Switch# show interface { fastethernet gigabitethernet tengigabitethernet } <i>slot/port</i> etherchannel | Verifies the configuration. |

This example shows how to remove Fast Ethernet interfaces 5/4 and 5/5 from port-channel 1:

```
Switch# configure terminal
Switch(config)# interface range fastethernet 5/4 - 5 (Note: Space is mandatory.)
Switch(config-if)# no channel-group 1
Switch(config-if)# end
```

Removing an EtherChannel

If you remove an EtherChannel, the member ports are shut down and removed from the channel group.



Note

If you want to change an EtherChannel from Layer 2 to Layer 3, or Layer 3 to Layer 2, you must remove the EtherChannel and recreate it in the desired configuration.

To remove an EtherChannel, perform this task:

| | Command | Purpose |
|--------|---|-------------------------------------|
| Step 1 | Switch(config)# no interface port-channel <i>port_channel_number</i> | Removes the port-channel interface. |
| Step 2 | Switch(config)# end | Exits configuration mode. |
| Step 3 | Switch# show etherchannel summary | Verifies the configuration. |

This example shows how to remove port-channel 1:

```
Switch# configure terminal
Switch(config)# no interface port-channel 1
Switch(config)# end
```

Displaying EtherChannel to a Virtual Switch System

Catalyst 4500 series switches support enhanced PAgP. If a Catalyst 4500 series switch is connected to a Catalyst 6500 series Virtual Switch System (VSS) via a PAgP EtherChannel, the Catalyst 4500 series switch will automatically serve as a VSS client, using enhanced PAgP on this EtherChannel for dual-active detection. This VSS client feature has no impact on the performance of Catalyst 4500 series switches and does not require any user configuration.

Topics include:

- [Understanding VSS Client, page 21-15](#)
- [Displaying EtherChannel Links to VSS, page 21-16](#)

Understanding VSS Client

Topics covered include:

- [Virtual Switch System, page 21-15](#)
- [Dual-Active Scenarios, page 21-15](#)
- [Dual-Active Detection Using Enhance PAgP, page 21-15](#)

Virtual Switch System

The Cisco Catalyst 6500 Series VSS 1440 allows for the combination of two Cisco Catalyst 6500 Series switches into a single, logical network entity from the network control-plane and management perspectives. Within the Cisco VSS, one chassis is designated as the active virtual switch, acting as the single management point of the entire system, and the other is designated as the standby virtual switch. These two chassis are bound together by a special link, called Virtual Switch Link (VSL), which carries the internal signaling and control information between them.

Dual-Active Scenarios

One of the failure scenarios in a VSS is called *dual-active*, which occurs when the VSL fails completely. In this case, neither virtual switch knows of the other's status. From the perspective of the active virtual switch, the standby chassis is lost. The standby virtual switch also views the active chassis as failed and transitions to active state via an SSO switchover. So, two active virtual switches will exist in the network with identical configurations, causing duplicate IP addresses and bridge identifiers. This scenario has adverse effects on the network topology and traffic if it persists.

Dual-Active Detection Using Enhance PAgP

One mechanism for detecting a dual-active scenario is based on enhanced PAgP (PAgP+). Specifically, the VSS sends regularly scheduled PAgP messages with Type-Length-Values (TLVs) containing the ID of the current active virtual switch ([Figure 21-1](#)). When the VSL fails completely, the standby virtual switch immediately sends asynchronous PAgP messages with TLVs containing its own ID on all port channels enabled for enhanced PAgP dual-active detection ([Figure 21-2](#)). The remote switch (the VSS client) connected to both VSS components via EtherChannel links, compares every received active ID with its stored active ID. If they match, the remote switch simply sends TLVs containing its stored active ID back to the VSS in its regularly scheduled PAgP messages. If they do not match, the

remote switch stores the new active ID and immediately transmits asynchronous PAgP messages with TLVs containing the new active ID. Upon receiving the new active ID from the remote switch, the original active virtual switch detects the dual-active scenario and takes appropriate actions.

Figure 21-1 Enhanced PAgP in VSS Normal Operation

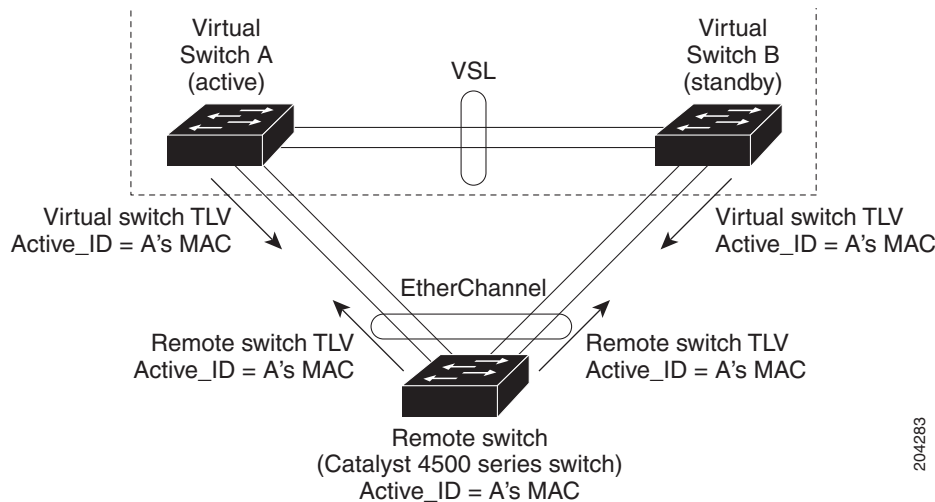
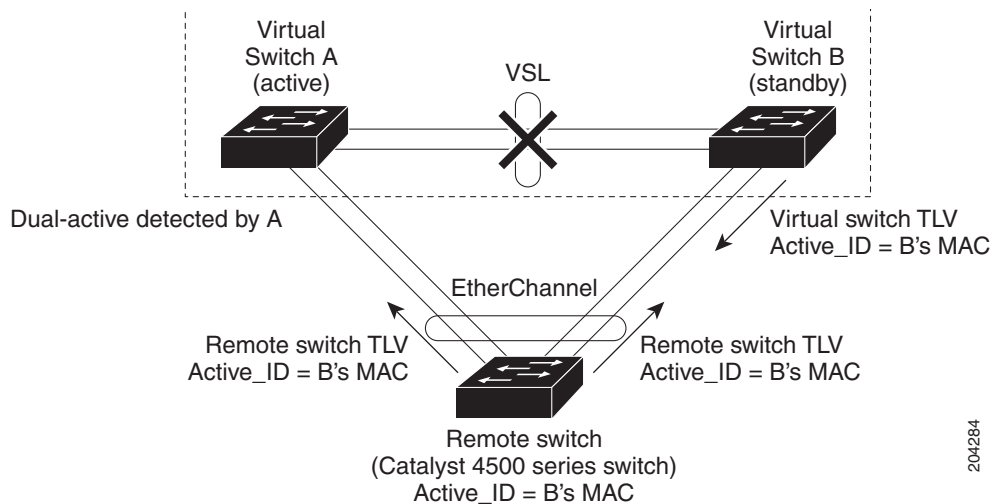

Figure 21-2 Enhanced PAgP in VSS Dual-active Scenario



As a remote switch, the Catalyst 4500 series switch supports stateful VSS client. In particular, the ID of the current active virtual switch is synchronized from the active supervisor engine to the redundant supervisor engine of the Catalyst 4500 series switch. This ensures that dual-active detection is not disrupted even when the active supervisor engine switches over to the redundant supervisor engine.

Displaying EtherChannel Links to VSS

To display the dual-active detection capability of the configured PAgP portchannel, use the `show pagp port_channel_number dual-active` command.

It indicates whether:

- A switch uses enhanced PAgP for dual-active detection.
You should always see “Yes” after “PAgP dual-active diction enabled” on a Catalyst 4500 switch.
- The configured PAgP EtherChannel is connected to a Catalyst 6500 switch VSS.
You will see “N/A” below “Partner Version” if this EtherChannel is *not* connected to a VSS. Otherwise, user will see the version of enhanced PAgP dual-active detection implemented in the VSS.
- This switch is capable of detecting dual-active scenarios in the connected VSS.
You will see “Yes” below “Dual-Active Detect Capable” if and only if the configured EtherChannel is connected to a Catalyst 6500 series VSS that uses the same version of enhanced PAgP dual-active detection.



Note

You can also see the name of the neighboring switch (Partner Name) and the ports to which this EtherChannel is connected (Partner Port).

If a Catalyst 4500 switch is connected to a Catalyst 6500 series VSS with the same version of enhanced PAgP dual-active detection, the switch *can* detect a dual-active scenario:

```
Switch# show pagp 1 dual-active
PAgP dual-active detection enabled: Yes
PAgP dual-active version: 1.1

Channel group 1
  Dual-Active   Partner      Partner      Partner
Port   Detect Capable Name          Port          Version
Gi6/5   Yes            VSS          Gi1/8/1       1.1
Gi6/6   Yes            VSS          Gi2/8/1       1.1
```

If a Catalyst 4500 switch is not connected to a Catalyst 6500 series VSS, the switch *cannot* detect a dual-active scenario:

```
Switch# show pagp 1 dual-active
PAgP dual-active detection enabled: Yes
PAgP dual-active version: 1.1

Channel group 1
  Dual-Active   Partner      Partner      Partner
Port   Detect Capable Name          Port          Version
Gi6/5   No            Switch       Fa6/5         N/A
Gi6/6   No            Switch       Fa6/6         N/A
```

