

# Configuring Flex Links and the MAC Address-Table Move Update Feature

**Note**

LAN Base image does not support Flex Links.

Flex Links provide a fast and simplified Layer 2 Link redundancy mechanism. This chapter describes how to configure Flex Links on the Catalyst 4500 series switch. It also describes how to configure the MAC address-table move update feature(MMU), also referred to as the Flex Links bidirectional fast convergence feature.

**Note**

For complete syntax and usage information for the commands used in this chapter, see the *Catalyst 4500 Metro Switch Command Reference* for this release.

The chapter consists of these sections:

- [Flex Links and the MAC Address-Table Move Update, page 18-1](#)
- [Configuring Flex Links and the MAC Address-Table Move Update, page 18-5](#)
- [Monitoring Flex Links and the MAC Address-Table Move Update, page 18-11](#)

## Flex Links and the MAC Address-Table Move Update

This section contains this information:

- [Flex Links, page 18-1](#)
- [VLAN Flex Link Load Balancing and Support, page 18-2](#)
- [MAC Address-Table Move Update, page 18-3](#)
- [Flex Link Failover Actions, page 18-4](#)

### Flex Links

Flex Links are a pair of Layer 2 interfaces (switch ports or port channels) where one interface is configured to act as a backup to the other. Users can disable STP and still retain basic link redundancy. Flex Links are typically configured in service provider or enterprise networks where customers do not want to run STP on some interfaces.

You configure Flex Links on one Layer 2 interface (the active link) by assigning another Layer 2 interface as the Flex Link or backup link. When one of the links is up and forwarding traffic, the other link is in standby mode, ready to begin forwarding traffic if the other link fails. At any given time, only one of the interfaces is in the forwarding state and forwarding traffic. If the primary link fails, the standby link starts forwarding traffic. When the active link reactivates, it enters standby mode and does not forward traffic. STP is disabled on Flex Link interfaces.

In [Figure 18-1](#), ports 1 and 2 on switch A are connected to uplink switches B and C. Because they are configured as Flex Links, only one of the interfaces is forwarding traffic; the other is in standby mode. If port 1 is the active link, it begins forwarding traffic between port 1 and switch B; the link between port 2 (the backup link) and switch C is not forwarding traffic. If port 1 shuts down, port 2 activates and starts forwarding traffic to switch C. When port 1 reactivates, it enters standby mode and does not forward traffic; port 2 continues forwarding traffic.

You can also choose to configure a preemption mechanism, specifying the preferred port for forwarding traffic. In [Figure 18-1](#), for example, you can configure the Flex Link pair with preemption mode so that after port 1 reactivates in the scenario, and it has greater bandwidth than port 2, port 1 begins forwarding after a duration equal to the preemption delay; and port 2 becomes the standby. You do this by entering the interface configuration **switchport backup interface preemption mode bandwidth** and **switchport backup interface preemption delay** commands.

**Figure 18-1 Flex Links Configuration Example**

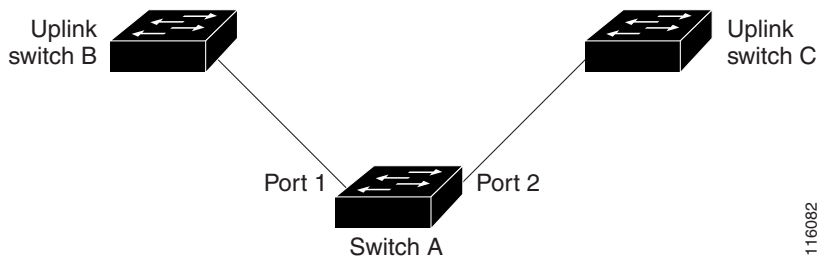

If a primary (forwarding) link shuts down, a trap notifies the network management stations. If the standby link shuts down, a trap notifies the users.

Flex Links are supported only on Layer 2 ports and port channels. Because Flex Links fully operate with PVLANS they may be configured on a pair of PVLAN trunks.

## VLAN Flex Link Load Balancing and Support

VLAN Flex Link load-balancing allows you to configure a Flex Link pair so that both ports simultaneously forward the traffic for mutually exclusive VLANs. For example, if Flex Link ports are configured for 1-100 VLANs, the traffic of the first 50 VLANs can be forwarded on one port and the rest on the other port. If one of the ports fail, the other active port forwards all the traffic. When the failed port reactivates, it resumes forwarding traffic in the preferred VLANs. This way, apart from providing the redundancy, this Flex Link pair can be used for load balancing. Also, Flex Link VLAN load-balancing does not impose any restrictions on uplink switches ([Figure 18-2](#)).

**Figure 18-2 VLAN Flex Links Load Balancing Configuration Example**

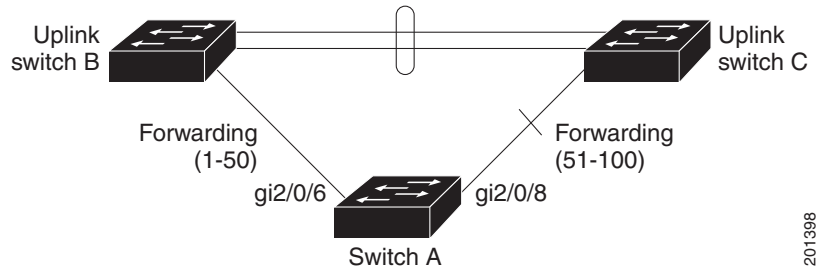

201398

**Note**

A static MAC address must point to a Flex Link interface that is forwarding for given VLAN. For example, if a backup interface is forwarding VLAN X, then a static MAC address in VLAN X must point to the backup interface. Misconfiguration might cause unexpected results.

## MAC Address-Table Move Update

In [Figure 18-3](#), ports 1 and 2 on switch A are connected to uplink switches B and D through a Flex Linkpair. Port 1 is forwarding traffic, and port 2 is in the blocking state. Traffic from the PC to the server is forwarded from port 1 to port 3. The MAC address of the PC has been learnt on port 3 of switch C. Traffic from the server to the PC is forwarded from port 3 to port 1.

If port 1 shuts down, port 2 starts forwarding traffic. If there is no traffic from PC to the server after failover to port 2, switch C does not learn MAC address of the PC on port 4. As a result, switch C keeps forwarding traffic from the server to the PC out of port 3. There is traffic loss from server to PC because port 1 is down. This problem is alleviated by sending out a dummy multicast packet with source MAC address of the PC over port 2. Switch C learns the PC MAC address on port 4 and start forwarding traffic from server to the PC out of port 4. One dummy multicast packet is sent out for every MAC address. This is the default flexlink behavior. The MAC address-table Move Update (MMU) feature may be enabled to further expedite downstream convergence. MMUs are special packets that carry multiple MAC addresses. Switch A is configured to transmit these packets and switches B, C and D are configured to receive such packets. If MMU transmit is enabled on Switch A, MAC move updates are transmitted before dummy multicast packets over port 2. Switch D processes and floods MMUs over to Switch C. Switch C processes these packets, and moves the MAC addresses contained within the packets from port 3 to port 4. Because one packet carries multiple MAC addresses, downstream convergence is faster.

Figure 18-3 MAC Address-Table Move Update Example

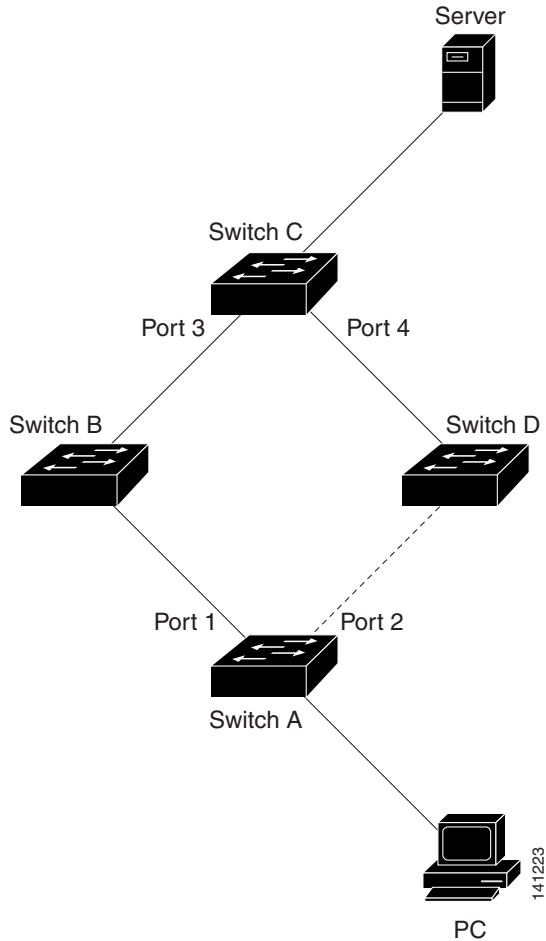

## Flex Link Failover Actions

Following are important actions that are performed when a Flex Link primary fails:

- Detect Link failure.
- Move static unicast MAC addresses configured on the primary link to the standby link.
- Move dynamic unicast MAC addresses learned on the primary link to the standby link.
- Move the standby link to a forwarding state.
- Transmit MAC Address-table Move updates over new active, if **Mac move update transmit** is enabled.
- Transmit dummy multicast packets over new active interface.



### Note

Local administrative shut down or a link becoming forwarding again due to preemption is not considered a link failure. The action in such cases is to flush dynamic hosts and not move them.

Static MAC address move on a Flex Link failover. Static MAC addresses configured on a Flex Link member interface are moved over to the backup, provided it fails. Static MAC addresses configured on a Flex Link member interface are restored when it becomes forwarding again.

**Note**

The `sh mac address-table` command always shows static MAC addresses as associated with the interface on which it was configured even if it may have been moved to the standby link because of a Flex Link failover.

## Configuring Flex Links and the MAC Address-Table Move Update

These sections contains the following information:

- [Default Configuration, page 18-5](#)
- [Configuration Guidelines, page 18-5](#)
- [Configuring Flex Links, page 18-6](#)
- [Configuring VLAN Load Balancing on Flex Links, page 18-8](#)
- [Configuring the MAC Address-Table Move Update Feature, page 18-9](#)

### Default Configuration

Observe the following points:

- Flex Links are not configured on any interface.
- Preemption mode is off.
- If preemption is enabled, preemption delay is 35 seconds.
- The MAC address-table move update feature is disabled.

### Configuration Guidelines

Follow these guidelines to configure Flex Links:

- You can configure only one Flex Link backup link for any active link, and it must be a different interface from the active interface.
- An interface can belong to only one Flex Link pair. An interface can be a backup link for only one active link, but an active link cannot belong to another Flex Link pair.
- Neither of the links can be a port that belongs to an EtherChannel. However, you can configure two port channels (EtherChannel logical interfaces) as Flex Links. Moreover, you can configure a port channel and a physical interface as Flex Links, with either the port channel or the physical interface as the active link.
- The types (Fast Ethernet, Gigabit Ethernet, or port channel) of the backup link and the active link can differ. However, you should configure both Flex Links with similar characteristics so that there are no loops or changes in behavior if the standby link begins to forward traffic.

- STP is disabled on Flex Link ports. A Flex Link port does not participate in STP, even if the VLANs present on the port are configured for STP. When STP is not enabled, ensure that there are no loops in the configured topology.
- Configure any static MAC addresses on a Flex Link member interface after enabling Flex Link.

Follow these guidelines to configure VLAN load balancing on the Flex Links feature:

- For Flex Link VLAN load balancing, you must choose the preferred VLANs on the backup interface.
- You cannot configure preemption and VLAN load balancing for the same Flex Links pair.

Follow these guidelines to configure the MAC address-table move update feature:

- Enable **mac address-table move transmit** on the switch with flexlinks configured to send MAC address-table move updates.
- Enable **mac address-table move receive** on all upstream switches to process MAC address-table move updates.

## Configuring Flex Links

To configure a pair of Flex Links, follow these steps:

	Command	Purpose
Step 1	<code>configure terminal</code>	Enters global configuration mode.
Step 2	<code>interface interface-id</code>	Specifies the interface, and enters interface configuration mode. The interface might be a physical Layer 2 interface or a port channel (logical interface). The port-channel range is 1 to 64.
Step 3	<code>switchport backup interface interface-id</code>	Configures a physical Layer 2 interface (or port channel) as part of a Flex Link pair with the interface. When one link is forwarding traffic, the other interface is in standby mode.
Step 4	<code>end</code>	Returns to privileged EXEC mode.
Step 5	<code>show interface [interface-id] switchport backup</code>	Verifies the configuration.
Step 6	<code>copy running-config startup config</code>	(Optional) Saves your entries in the switch startup configuration file.

To disable a Flex Link backup interface, enter the **no switchport backup interface interface-id** interface configuration command.

This example shows how to configure an interface with a backup interface and to verify the configuration:

```
Switch# configure terminal
Switch(conf)# interface fastethernet1/1
Switch(conf-if)# switchport backup interface fastethernet1/2
Switch(conf-if)# end
Switch# show interface switchport backup
Switch Backup Interface Pairs:

Active Interface      Backup Interface      State
-----
FastEthernet1/1      FastEthernet1/2      Active Up/Backup Standby
```

```
FastEthernet1/3      FastEthernet1/4      Active Up/Backup Standby
Port-channel1       GigabitEthernet1/1   Active Up/Backup Standby
```

To configure a preemption scheme for a pair of Flex Links, follow these steps:

	Command	Purpose
Step 1	<code>configure terminal</code>	Enters global configuration mode.
Step 2	<code>interface interface-id</code>	Specifies the interface, and enters interface configuration mode. The interface might be a physical Layer 2 interface or a port channel (logical interface). The port-channel range is 1 to 64.
Step 3	<code>switchport backup interface interface-id</code>	Configures a physical Layer 2 interface (or port channel) as part of a Flex Link pair with the interface. When one link is forwarding traffic, the other interface is in standby mode.
Step 4	<code>switchport backup interface interface-id preemption mode [forced   bandwidth   off]</code>	Configures a preemption mechanism and delay for a Flex Link interface pair. You can configure the preemption mode as: <ul style="list-style-type: none"> <li>• <b>forced</b>—the active interface always preempts the backup</li> <li>• <b>bandwidth</b>—the interface with higher bandwidth always acts as the active interface</li> <li>• <b>off</b>—no preemption happens from active to backup</li> </ul>
Step 5	<code>switchport backup interface interface-id preemption delay delay-time</code>	Configures the delay time until a port preempts another port. <b>Note</b> Setting a delay time work only with forced and bandwidth modes.
Step 6	<code>end</code>	Returns to privileged EXEC mode.
Step 7	<code>show interface [interface-id] switchport backup</code>	Verifies the configuration.
Step 8	<code>copy running-config startup config</code>	(Optional) Saves your entries in the switch startup configuration file.

To remove a preemption scheme, enter the **no switchport backup interface interface-id preemption mode** interface configuration command. To reset the delay time to the default, enter the **no switchport backup interface interface-id preemption delay** interface configuration command.

This example shows how to configure preemption mode as bandwidth for a backup interface pair and to verify the configuration:

```
Switch# configure terminal
Switch(conf)# interface gigabitethernet1/0/1
Switch(conf-if)# switchport backup interface gigabitethernet1/2
Switch(conf-if)# switchport backup interface gigabitethernet1/2 preemption mode forced
Switch(conf-if)# switchport backup interface gigabitethernet1/2 preemption delay 50
Switch(conf-if)# end
Switch# show interface switchport backup detail
Active Interface      Backup Interface      State
-----
GigabitEthernet1/21  GigabitEthernet1/2    Active Down/Backup Down
Interface Pair       : Gi1/21, Gi1/2
Preemption Mode      : forced
```

```

Preemption Delay : 50 seconds
Bandwidth : 10000 Kbit (Gi1/1), 10000 Kbit (Gi1/2)
Mac Address Move Update Vlan : auto

<output truncated>

```

## Configuring VLAN Load Balancing on Flex Links

To configure VLAN load balancing on Flex Links, follow these steps:

	Command	Purpose
Step 1	<code>configure terminal</code>	Enters global configuration mode.
Step 2	<code>interface interface-id</code>	Specifies the interface, and enters interface configuration mode. The interface might be a physical Layer 2 interface or a port channel (logical interface). The port-channel range is 1 to 48.
Step 3	<code>switchport backup interface interface-id prefer vlan vlan-range</code>	Configures a physical Layer 2 interface (or port channel) as part of a Flex Links pair with the interface, and specifies the VLANs carried on the interface. The VLAN ID range is 1 to 4094.
Step 4	<code>end</code>	Returns to privileged EXEC mode.
Step 5	<code>show interfaces [interface-id] switchport backup</code>	Verifies the configuration.
Step 6	<code>copy running-config startup config</code>	(Optional) Saves your entries in the switch startup configuration file.

To disable the VLAN load balancing feature, enter the **no switchport backup interface interface-id prefer vlan vlan-range** interface configuration command.

In this example, VLANs 1 to 50, 60, and 100 to 120 are configured on the switch:

```

Switch(config)# interface fastethernet 1/6
Switch(config-if)# switchport backup interface fastethernet 1/0/8 prefer vlan 60,100-120

```

When both interfaces are up, Fast Ethernet port1/0/8 forwards traffic for VLANs 60 and 100 to 120 and Fast Ethernet port 1/0/6 forwards traffic for VLANs 1 to 50.

```

Switch# show interfaces switchport backup
Switch Backup Interface Pairs:

```

```

Active Interface      Backup Interface      State
-----
FastEthernet1/6      FastEthernet1/8      Active Up/Backup Standby

```

```

Vlans Preferred on Active Interface: 1-50
Vlans Preferred on Backup Interface: 60, 100-120

```

When a Flex Link interface shuts down, VLANs preferred on this interface are moved to the peer interface of the Flex Link pair. In this example, if interface 1/6 shuts down, interface 1/8 carries all VLANs of the Flex Link pair.

```

Switch# show interfaces switchport backup
Switch Backup Interface Pairs:

```

```

Active Interface      Backup Interface      State

```



```
-----
FastEthernet1/6 FastEthernet1/8   Active Down/Backup VLB all
```

```
Vlans Preferred on Active Interface: 1-50
Vlans Preferred on Backup Interface: 60, 100-120
```

When a Flex Link interface becomes active, VLANs preferred on this interface are blocked on the peer interface and moved to the forwarding state on the interface that has just come up. In this example, if interface Fast Ethernet port 1/6 becomes active, VLANs preferred on this interface are blocked on the peer interface Fast Ethernet port 1/8 and forwarded on Fast Ethernet port 1/6.

```
Switch# show interfaces switchport backup
Switch Backup Interface Pairs:
```

```
Active Interface      Backup Interface      State
-----
FastEthernet1/6      FastEthernet1/8      Active VLB cfg/Backup VLB cfg
```

```
Vlans Preferred on Active Interface: 1-50
Vlans Preferred on Backup Interface: 60, 100-120
```

```
Switch# show interfaces switchport backup detail
Switch Backup Interface Pairs:
```

```
Active Interface      Backup Interface      State
-----
FastEthernet1/6      FastEthernet1/8      Active VLB cfg/Backup VLB cfg
```

```
Vlans Preferred on Active Interface: 1-50
Vlans Preferred on Backup Interface: 60, 100-120
Preemption Mode      : off
Bandwidth : 10000 Kbit (Fa1/6), 100000 Kbit (Fa1/8)
Mac Address Move Update Vlan : auto
```

## Configuring the MAC Address-Table Move Update Feature

This section contains this information:

- Configuring a switch to send MAC address-table move updates
- Configuring a switch to receive MAC address-table move updates

To configure an access switch to send MAC address-table move updates, follow these steps:

	Command	Purpose
Step 1	<code>configure terminal</code>	Enters global configuration mode.
Step 2	<code>interface interface-id</code>	Specifies the interface, and enters interface configuration mode. The interface might be a physical Layer 2 interface or a port channel (logical interface). The port-channel range is 1 to 64.

	Command	Purpose
Step 3	<code>switchport backup interface interface-id</code> or <code>switchport backup interface interface-id mmu primary vlan vlan-id</code>	Configures a physical Layer 2 interface (or port channel), as part of a Flex Link pair with the interface. The MAC address-table move update VLAN is the lowest VLAN ID on the interface.  Configures a physical Layer 2 interface (or port channel) and specifies the VLAN ID on the interface, which is used for sending the MAC address-table move update.  When one link is forwarding traffic, the other interface is in standby mode.
Step 4	<code>end</code>	Returns to global configuration mode.
Step 5	<code>mac address-table move update transmit</code>	Enables the access switch to send MAC address-table move updates to other switches in the network if the primary link shuts down and the switch starts forwarding traffic through the standby link.
Step 6	<code>end</code>	Returns to privileged EXEC mode.
Step 7	<code>show mac address-table move update</code>	Verifies the configuration.
Step 8	<code>copy running-config startup config</code>	(Optional) Saves your entries in the switch startup configuration file.

To disable the MAC address-table move update feature on the access switch, enter the **no mac address-table move update transmit** interface configuration command. To display the MAC address-table move update information, enter the **show mac address-table move update** command.

This example shows how to configure an access switch to send MAC address-table move update messages and to verify the configuration:

```
Switch# configure terminal
Switch(conf)# interface fastethernet1/1
Switch(conf-if)# switchport backup interface fastethernet1/0/2 mmu primary vlan 2
Switch(conf-if)# end
Switch(conf)# mac address-table move update transmit
Switch(conf)# end
Switch# show mac-address-table move update
Switch-ID : 01d0.2bfc.3180
Dst mac-address : 0180.c200.0010
Vlans/Macs supported : 4096/55000
Default/Current settings: Rcv Off/Off, Xmt Off/On
Max packets per min : Rcv 100, Xmt 120
Rcv packet count : 0
Rcv conforming packet count : 0
Rcv invalid packet count : 0
Rcv packet count this min : 0
Rcv threshold exceed count : 0
Rcv last sequence# this min : 0
Rcv last interface : None
Rcv last src-mac-address : 0000.0000.0000
Rcv last switch-ID : 0000.0000.0000
Xmt packet count : 0
Xmt packet count this min : 0
Xmt threshold exceed count : 0
Xmt pak buf unavail cnt : 0
Xmt last interface : fa1/2
```

To configure a switch to receive and process MAC address-table move update messages, do the following:

	Command	Purpose
Step 1	<code>configure terminal</code>	Enters global configuration mode.
Step 2	<code>mac address-table move update receive</code>	Enables the switch to receive and process the MAC address-table move updates.
Step 3	<code>end</code>	Returns to privileged EXEC mode.
Step 4	<code>show mac address-table move update</code>	Verifies the configuration.
Step 5	<code>copy running-config startup config</code>	(Optional) Saves your entries in the switch startup configuration file.

To disable the MAC address-table move update feature on the access switch, enter the **no mac address-table move update receive** configuration command. To display the MAC address-table move update information, enter the **show mac address-table move update** command.

This example shows how to configure a switch to receive and process MAC address-table move update messages:

```
Switch# configure terminal
Switch(conf)# mac address-table move update receive
Switch(conf)# end
```

## Monitoring Flex Links and the MAC Address-Table Move Update

Table 18-1 shows the commands for monitoring the Flex Links configuration and the MAC address-table move update information.

**Table 18-1** Flex Links and MAC Address-Table Move Update Monitoring Commands

Command	Purpose
<code>show interface [interface-id] switchport backup</code>	Displays the Flex Link backup interface configured for an interface or all the configured Flex Links and the state of each active and backup interface (up or standby mode).
<code>show mac address-table move update</code>	Displays the MAC address-table move update information on the switch.

