



## **Catalyst 4900 Series Switch Installation Guide**

August 2008

### **Americas Headquarters**

Cisco Systems, Inc.  
170 West Tasman Drive  
San Jose, CA 95134-1706  
USA  
<http://www.cisco.com>  
Tel: 408 526-4000  
800 553-NETS (6387)  
Fax: 408 527-0883

Text Part Number: 78-18039-02

THE SPECIFICATIONS AND INFORMATION REGARDING THE PRODUCTS IN THIS MANUAL ARE SUBJECT TO CHANGE WITHOUT NOTICE. ALL STATEMENTS, INFORMATION, AND RECOMMENDATIONS IN THIS MANUAL ARE BELIEVED TO BE ACCURATE BUT ARE PRESENTED WITHOUT WARRANTY OF ANY KIND, EXPRESS OR IMPLIED. USERS MUST TAKE FULL RESPONSIBILITY FOR THEIR APPLICATION OF ANY PRODUCTS.

THE SOFTWARE LICENSE AND LIMITED WARRANTY FOR THE ACCOMPANYING PRODUCT ARE SET FORTH IN THE INFORMATION PACKET THAT SHIPPED WITH THE PRODUCT AND ARE INCORPORATED HEREIN BY THIS REFERENCE. IF YOU ARE UNABLE TO LOCATE THE SOFTWARE LICENSE OR LIMITED WARRANTY, CONTACT YOUR CISCO REPRESENTATIVE FOR A COPY.

The following information is for FCC compliance of Class A devices: This equipment has been tested and found to comply with the limits for a Class A digital device, pursuant to part 15 of the FCC rules. These limits are designed to provide reasonable protection against harmful interference when the equipment is operated in a commercial environment. This equipment generates, uses, and can radiate radio-frequency energy and, if not installed and used in accordance with the instruction manual, may cause harmful interference to radio communications. Operation of this equipment in a residential area is likely to cause harmful interference, in which case users will be required to correct the interference at their own expense.

The following information is for FCC compliance of Class B devices: The equipment described in this manual generates and may radiate radio-frequency energy. If it is not installed in accordance with Cisco's installation instructions, it may cause interference with radio and television reception. This equipment has been tested and found to comply with the limits for a Class B digital device in accordance with the specifications in part 15 of the FCC rules. These specifications are designed to provide reasonable protection against such interference in a residential installation. However, there is no guarantee that interference will not occur in a particular installation.

Modifying the equipment without Cisco's written authorization may result in the equipment no longer complying with FCC requirements for Class A or Class B digital devices. In that event, your right to use the equipment may be limited by FCC regulations, and you may be required to correct any interference to radio or television communications at your own expense.

You can determine whether your equipment is causing interference by turning it off. If the interference stops, it was probably caused by the Cisco equipment or one of its peripheral devices. If the equipment causes interference to radio or television reception, try to correct the interference by using one or more of the following measures:

- Turn the television or radio antenna until the interference stops.
- Move the equipment to one side or the other of the television or radio.
- Move the equipment farther away from the television or radio.
- Plug the equipment into an outlet that is on a different circuit from the television or radio. (That is, make certain the equipment and the television or radio are on circuits controlled by different circuit breakers or fuses.)

Modifications to this product not authorized by Cisco Systems, Inc. could void the FCC approval and negate your authority to operate the product.

The Cisco implementation of TCP header compression is an adaptation of a program developed by the University of California, Berkeley (UCB) as part of UCB's public domain version of the UNIX operating system. All rights reserved. Copyright © 1981, Regents of the University of California.

NOTWITHSTANDING ANY OTHER WARRANTY HEREIN, ALL DOCUMENT FILES AND SOFTWARE OF THESE SUPPLIERS ARE PROVIDED "AS IS" WITH ALL FAULTS. CISCO AND THE ABOVE-NAMED SUPPLIERS DISCLAIM ALL WARRANTIES, EXPRESSED OR IMPLIED, INCLUDING, WITHOUT LIMITATION, THOSE OF MERCHANTABILITY, FITNESS FOR A PARTICULAR PURPOSE AND NONINFRINGEMENT OR ARISING FROM A COURSE OF DEALING, USAGE, OR TRADE PRACTICE.

IN NO EVENT SHALL CISCO OR ITS SUPPLIERS BE LIABLE FOR ANY INDIRECT, SPECIAL, CONSEQUENTIAL, OR INCIDENTAL DAMAGES, INCLUDING, WITHOUT LIMITATION, LOST PROFITS OR LOSS OR DAMAGE TO DATA ARISING OUT OF THE USE OR INABILITY TO USE THIS MANUAL, EVEN IF CISCO OR ITS SUPPLIERS HAVE BEEN ADVISED OF THE POSSIBILITY OF SUCH DAMAGES.

CCDE, CCENT, Cisco Eos, Cisco Lumin, Cisco Nexus, Cisco StadiumVision, Cisco TelePresence, the Cisco logo, DCE, and Welcome to the Human Network are trademarks; Changing the Way We Work, Live, Play, and Learn and Cisco Store are service marks; and Access Registrar, Aironet, AsyncOS, Bringing the Meeting To You, Catalyst, CCDA, CCDP, CCIE, CCIP, CCNA, CCNP, CCSP, CCVP, Cisco, the Cisco Certified Internetwork Expert logo, Cisco IOS, Cisco Press, Cisco Systems, Cisco Systems Capital, the Cisco Systems logo, Cisco Unity, Collaboration Without Limitation, EtherFast, EtherSwitch, Event Center, Fast Step, Follow Me Browsing, FormShare, GigaDrive, HomeLink, Internet Quotient, IOS, iPhone, iQ Expertise, the iQ logo, iQ Net Readiness Scorecard, iQuick Study, IronPort, the IronPort logo, LightStream, Linksys, MediaTone, MeetingPlace, MeetingPlace Chime Sound, MGX, Networkers, Networking Academy, Network Registrar, PCNow, PIX, PowerPanels, ProConnect, ScriptShare, SenderBase, SMARTnet, Spectrum Expert, StackWise, The Fastest Way to Increase Your Internet Quotient, TransPath, WebEx, and the WebEx logo are registered trademarks of Cisco Systems, Inc. and/or its affiliates in the United States and certain other countries.

All other trademarks mentioned in this document or Website are the property of their respective owners. The use of the word partner does not imply a partnership relationship between Cisco and any other company. (0807R)

*Catalyst 4900 Series Switch Installation Guide*

Copyright © 2008 Cisco Systems, Inc. All rights reserved.







## **C O N T E N T S**

### **Preface ix**

Audience **ix**

Organization **ix**

Related Documentation **x**

Command Syntax Conventions **xi**

Statement 1071—Warning Definition **xii**

Obtaining Documentation and Submitting a Service Request **xxi**

---

### **CHAPTER 1**

#### **Product Overview 1-1**

Catalyst 4900 Series Switch Applications **1-2**

Catalyst 4948 Switch Software Features **1-3**

Catalyst 4948-10GE and Catalyst 4928-10GE Switch Software Features **1-4**

Hardware System Features **1-6**

Switch Components **1-7**

Traffic Ports on the Catalyst 4948 **1-7**

Traffic Ports on the Catalyst 4948-10GE **1-7**

Traffic Ports on the Catalyst 4928-10GE **1-7**

Console Port **1-7**

Front Panel LEDs **1-9**

Chassis Cooling **1-11**

Power Supplies **1-12**

Environmental Monitoring of the Power Supplies **1-13**

Power Management for the Switch **1-14**

Power Management Modes **1-14**

---

### **CHAPTER 2**

#### **Site Planning 2-1**

Site Environmental Requirements **2-1**

Site Power Requirements **2-2**

Pre-installation Requirements **2-3**

Warnings and Cautions **2-3**

- EMI Recommendations **2-4**
- Power Requirements and Heat Dissipation **2-4**
- Grounding Requirements **2-6**
- Safety Overview **2-7**
  - Ensuring Safety **2-7**
  - Working Safely with Electricity **2-8**
  - Preventing Electrostatic Discharge Damage **2-9**
- Site Planning Checklist **2-9**

---

**CHAPTER 3****Installing the Switch 3-1**

- Verifying the Contents **3-1**
- Rack-Mounting the Switch **3-2**
  - Rack-Mounting Guidelines **3-3**
  - Lifting the Chassis Safely **3-5**
  - Required Installation Tools **3-5**
  - Rack-Mounting the Switch **3-6**
- Connecting AC Power to the Switch **3-9**
- Connecting DC Power to the Switch **3-11**

---

**CHAPTER 4****Transceiver Modules 4-1**

- SFP Modules **4-1**
  - SFP Modules and Alternative Wiring **4-1**
- X2 Modules **4-2**
  - Module Maintenance Guidelines **4-5**
- Cleaning the Fiber-Optic Connectors **4-5**
  - Additional Guidelines **4-7**

---

**CHAPTER 5****Troubleshooting the Installation 5-1**

- Getting Started **5-2**
- Problem Solving to the System Component Level **5-2**
- Identifying Startup Problems **5-3**
  - LED Readings **5-3**
- Troubleshooting the Power Supply **5-5**
- Contacting Customer Service **5-6**

---

**APPENDIX A****Specifications A-1**

- Console Port **A-1**

Management Port **A-2**  
Catalyst 4900 Series Switch Specifications **A-3**

---

**APPENDIX B****Initial Configuration for the Switch B-1**

Connecting to the Switch **B-2**  
Starting the Terminal-Emulation Software **B-3**  
Connecting to a Power Source **B-3**  
Entering the Initial Configuration Information **B-4**  
    IP Settings **B-4**  
    Performing the Initial Configuration **B-5**

---

**APPENDIX C****Compliance Information and Translated Safety Warnings C-1**

Translated Safety Warnings **C-2**  
    Statement 1003—DC Power Disconnection **C-2**  
    Statement 1004—Installation Instructions **C-4**  
    Statement 1006—Chassis Warning for Rack-Mounting and Servicing **C-6**  
    Statement 1008—Class 1 Laser Product **C-14**  
    Statement 1011—Staring into Laser Beam **C-16**  
    Statement 1017—Restricted Area **C-18**  
    Statement 1019—Main Disconnecting Device **C-21**  
    Statement 1024—Ground Conductor **C-23**  
    Statement 1030—Equipment Installation **C-25**  
    Statement 1040—Product Disposal **C-27**  
    Statement 1045—Short-circuit Protection **C-30**  
    Statement 1051—Laser Radiation **C-33**  
    Statement 1074—Comply with Local and National Electrical Codes **C-36**  
    Statement 1075—Hazardous Voltage or Energy Present on DC Power Terminals **C-37**  
Regulatory Standards Compliance **C-39**  
European Directives **C-42**  
    Statement 287—Declaration of Conformity to R&TTE Directive 1999/5/EC for the European Community, Switzerland, Norway, Iceland and Liechtenstein **C-42**  
    Statement 275—Declaration of Conformity with Regard to the Directives 73/23/EEC and 89/336/EEC as amended by Directive 93/68/EEC **C-44**  
    California Perchlorate Contamination Prevention Act (Title 22, California Code of Regulations, Chapter 33) **C-46**  
EMC Class A Notices and Warnings **C-46**  
    Class A Notice for FCC **C-46**  
    Class A Notice for Canada **C-47**  
    Statement 340—Class A Warning for CISPR22 **C-47**

---

Statement 191—VCCI Class A Warning for Japan **C-50**  
Statement 256—Class A Warning for Hungary **C-51**  
Statement 294—Class A Warning for Korea **C-51**  
Statement 257—Class A Notice for Taiwan and Other Traditional Chinese Markets **C-52**  
Statement 371—Power Cable and AC Adapter **C-52**

---

**INDEX**



## Preface

---

This preface describes the audience, organization, and conventions of the *Catalyst 4900 Series Switch Installation Guide* and provides information on how to obtain related documentation.

## Audience

Only trained and qualified service personnel (as defined in IEC60950-1 and AZ/NZS 60950-1) should install, replace, or service the equipment.

## Organization

This guide is organized as follows:

Chapter	Title	Description
Chapter 1	Product Overview	Describes the hardware features and functionality of the Catalyst 4900 series switches.
Chapter 2	Site Planning	Describes how to prepare your site for the installation of the switch.
Chapter 3	Installing the Switch	Details how to install the switch.
Chapter 4	Transceiver Modules	Describes how to install, remove, and maintain transceiver modules.

Chapter	Title	Description
Chapter 5	Troubleshooting the Installation	Provides troubleshooting guidelines for the initial hardware installation and suggests steps to help isolate and resolve problems.
Appendix A	Specifications	Lists the switch system specifications.
Appendix B	Initial Configuration for the Switch	Details initial setup of a system that will allow further configuration via Telnet.
Appendix C	Compliance Information and Translated Safety Warnings	States compliance information for the switches and repeats in multiple languages the warnings in this guide.

## Related Documentation

The Catalyst 4900 series switches use software that also runs on the Catalyst 4500 series switches. Refer to the version of these documents appropriate for your software release:

- *Catalyst 4500 Series Switch Cisco IOS Software Configuration Guide*  
[http://www.cisco.com/en/US/products/hw/switches/ps4324/products\\_installation\\_and\\_configuration\\_guides\\_list.html](http://www.cisco.com/en/US/products/hw/switches/ps4324/products_installation_and_configuration_guides_list.html)
- *Catalyst 4500 Series Switch Cisco IOS Command Reference*  
[http://www.cisco.com/en/US/products/hw/switches/ps4324/prod\\_command\\_reference\\_list.html](http://www.cisco.com/en/US/products/hw/switches/ps4324/prod_command_reference_list.html)
- *Catalyst 4500 Series Switch Cisco IOS System Message Guide*  
[http://www.cisco.com/en/US/products/hw/switches/ps4324/products\\_system\\_message\\_guides\\_list.html](http://www.cisco.com/en/US/products/hw/switches/ps4324/products_system_message_guides_list.html)

There is a distinct release note for the Catalyst 4900 switches. It is available at:

[http://www.cisco.com/en/US/docs/switches/lan/catalyst4500/release/note/OL\\_9592.html](http://www.cisco.com/en/US/docs/switches/lan/catalyst4500/release/note/OL_9592.html)

# Command Syntax Conventions

This section Table 1 describes the syntax used with the commands in this document.

**Table 1**      **Command Syntax Guide**

Convention	Description
<b>boldface</b>	Commands and keywords.
<i>italic</i>	Command input that is supplied by you.
[   ]	Keywords or arguments that appear within square brackets are optional.
{ x   x   x }	A choice of keywords (represented by x) appears in braces separated by vertical bars. You must select one.
^ or Ctrl	Represent the key labeled <i>Control</i> . For example, when you read ^D or <i>Ctrl-D</i> , you should hold down the Control key while you press the D key.
screen font	Examples of information displayed on the screen.
<b>boldface screen font</b>	Examples of information that you must enter.
< >	Nonprinting characters, such as passwords, appear in angled brackets.
[   ]	Default responses to system prompts appear in square brackets.



**Note**

Means *reader take note*.



**Tip**

Means *the following information will help you solve a problem*.



**Caution**

Means *reader be careful*. In this situation, you might perform an action that could result in equipment damage or loss of data.



---

**Timesaver**

Means *the described action saves time*. You can save time by performing the action described in the paragraph.

---



---

**Warning**

Means *reader be warned*. In this situation, you might perform an action that could result in bodily injury.

---

## Statement 1071—Warning Definition



---

**Warning**

### **IMPORTANT SAFETY INSTRUCTIONS**

**This warning symbol means danger. You are in a situation that could cause bodily injury. Before you work on any equipment, be aware of the hazards involved with electrical circuitry and be familiar with standard practices for preventing accidents. Use the statement number provided at the end of each warning to locate its translation in the translated safety warnings that accompanied this device.** Statement 1071

### **SAVE THESE INSTRUCTIONS**

**Waarschuwing**

### **BELANGRIJKE VEILIGHEIDSINSTRUCTIES**

**Dit waarschuwingssymbool betekent gevaar. U verkeert in een situatie die lichamelijk letsel kan veroorzaken. Voordat u aan enige apparatuur gaat werken, dient u zich bewust te zijn van de bij elektrische schakelingen betrokken risico's en dient u op de hoogte te zijn van de standaard praktijken om ongelukken te voorkomen. Gebruik het nummer van de verklaring onderaan de waarschuwing als u een vertaling van de waarschuwing die bij het apparaat wordt geleverd, wilt raadplegen.**

### **BEWAAR DEZE INSTRUCTIES**



**Varoitus TÄRKEITÄ TURVALLISUUSOHJEITA**

Tämä varoitusmerkki merkitsee vaaraa. Tilanne voi aiheuttaa ruumiillisia vammoja. Ennen kuin käsittelet laitteistoa, huomioi sähköpiirien käsittelemiseen liittyvät riskit ja tutustu onnettomuuksien yleisiin ehkäisytapoihin. Turvallisuusvaroitusten käännökset löytyvät laitteen mukana toimitettujen käännettyjen turvallisuusvaroitusten joukosta varoitusten lopussa näkyvien lausuntonumeroiden avulla.

**SÄILYTÄ NÄMÄ OHJEET****Attention IMPORTANTES INFORMATIONS DE SÉCURITÉ**

Ce symbole d'avertissement indique un danger. Vous vous trouvez dans une situation pouvant entraîner des blessures ou des dommages corporels. Avant de travailler sur un équipement, soyez conscient des dangers liés aux circuits électriques et familiarisez-vous avec les procédures couramment utilisées pour éviter les accidents. Pour prendre connaissance des traductions des avertissements figurant dans les consignes de sécurité traduites qui accompagnent cet appareil, référez-vous au numéro de l'instruction situé à la fin de chaque avertissement.

**CONSERVEZ CES INFORMATIONS****Warnung WICHTIGE SICHERHEITSHINWEISE**

Dieses Warnsymbol bedeutet Gefahr. Sie befinden sich in einer Situation, die zu Verletzungen führen kann. Machen Sie sich vor der Arbeit mit Geräten mit den Gefahren elektrischer Schaltungen und den üblichen Verfahren zur Vorbeugung vor Unfällen vertraut. Suchen Sie mit der am Ende jeder Warnung angegebenen Anweisungsnummer nach der jeweiligen Übersetzung in den übersetzten Sicherheitshinweisen, die zusammen mit diesem Gerät ausgeliefert wurden.

**BEWAHREN SIE DIESE HINWEISE GUT AUF.**

**Avvertenza      IMPORTANTI ISTRUZIONI SULLA SICUREZZA**

**Questo simbolo di avvertenza indica un pericolo. La situazione potrebbe causare infortuni alle persone. Prima di intervenire su qualsiasi apparecchiatura, occorre essere al corrente dei pericoli relativi ai circuiti elettrici e conoscere le procedure standard per la prevenzione di incidenti. Utilizzare il numero di istruzione presente alla fine di ciascuna avvertenza per individuare le traduzioni delle avvertenze riportate in questo documento.**

**CONSERVARE QUESTE ISTRUZIONI****Advarsel      VIKTIGE SIKKERHETSINSTRUKSJONER**

**Dette advarselssymbolet betyr fare. Du er i en situasjon som kan føre til skade på person. Før du begynner å arbeide med noe av utstyret, må du være oppmerksom på farene forbundet med elektriske kretser, og kjenne til standardprosedyrer for å forhindre ulykker. Bruk nummeret i slutten av hver advarsel for å finne oversettelsen i de oversatte sikkerhetsadvarslene som fulgte med denne enheten.**

**TA VARE PÅ DISSE INSTRUKSJONENE****Aviso      INSTRUÇÕES IMPORTANTES DE SEGURANÇA**

**Este símbolo de aviso significa perigo. Você está em uma situação que poderá ser causadora de lesões corporais. Antes de iniciar a utilização de qualquer equipamento, tenha conhecimento dos perigos envolvidos no manuseio de circuitos elétricos e familiarize-se com as práticas habituais de prevenção de acidentes. Utilize o número da instrução fornecido ao final de cada aviso para localizar sua tradução nos avisos de segurança traduzidos que acompanham este dispositivo.**

**GUARDE ESTAS INSTRUÇÕES**

**¡Advertencia! INSTRUCCIONES IMPORTANTES DE SEGURIDAD**

**Este símbolo de aviso indica peligro. Existe riesgo para su integridad física. Antes de manipular cualquier equipo, considere los riesgos de la corriente eléctrica y familiarícese con los procedimientos estándar de prevención de accidentes. Al final de cada advertencia encontrará el número que le ayudará a encontrar el texto traducido en el apartado de traducciones que acompaña a este dispositivo.**

**GUARDE ESTAS INSTRUCCIONES****Varning! VIKTIGA SÄKERHETSANVISNINGAR**

**Denna varningssignal signalerar fara. Du befinner dig i en situation som kan leda till personskada. Innan du utför arbete på någon utrustning måste du vara medveten om farorna med elkretsar och känna till vanliga förfaranden för att förebygga olyckor. Använd det nummer som finns i slutet av varje varning för att hitta dess översättning i de översatta säkerhetsvarningar som medföljer denna anordning.**

**SPARA DESSA ANVISNINGAR**

**Aviso INSTRUÇÕES IMPORTANTES DE SEGURANÇA**

**Este símbolo de aviso significa perigo. Você se encontra em uma situação em que há risco de lesões corporais. Antes de trabalhar com qualquer equipamento, esteja ciente dos riscos que envolvem os circuitos elétricos e familiarize-se com as práticas padrão de prevenção de acidentes. Use o número da declaração fornecido ao final de cada aviso para localizar sua tradução nos avisos de segurança traduzidos que acompanham o dispositivo.**

**GUARDE ESTAS INSTRUÇÕES****Advarsel VIGTIGE SIKKERHEDSANVISNINGER**

**Dette advarselssymbol betyder fare. Du befinder dig i en situation med risiko for legemesbeskadigelse. Før du begynder arbejde på udstyr, skal du være opmærksom på de involverede risici, der er ved elektriske kredsløb, og du skal sætte dig ind i standardprocedurer til undgåelse af ulykker. Brug erklæringsnummeret efter hver advarsel for at finde oversættelsen i de oversatte advarsler, der fulgte med denne enhed.**

**GEM DISSE ANVISNINGER**

**Figyelem FONTOS BIZTONSÁGI ELOÍRÁSOK**

**Ez a figyelmeztető jel veszélyre utal. Sérülésveszélyt rejtő helyzetben van. Mielőtt bármely berendezésen munkát végezte, legyen figyelemmel az elektromos áramkörök okozta kockázatokra, és ismerkedjen meg a szokásos balesetvédelmi eljárásokkal. A kiadványban szereplő figyelmeztetések fordítása a készülékhez mellékelt biztonsági figyelmeztetések között található; a fordítás az egyes figyelmeztetések végén látható szám alapján kereshető meg.**

**ORIZZE MEG EZEKET AZ UTASÍTÁSOKAT!**

**Предупреждение ВАЖНЫЕ ИНСТРУКЦИИ ПО СОБЛЮДЕНИЮ ТЕХНИКИ БЕЗОПАСНОСТИ**

**Этот символ предупреждения обозначает опасность. То есть имеет место ситуация, в которой следует опасаться телесных повреждений. Перед эксплуатацией оборудования выясните, каким опасностям может подвергаться пользователь при использовании электрических цепей, и ознакомьтесь с правилами техники безопасности для предотвращения возможных несчастных случаев. Воспользуйтесь номером заявления, приведенным в конце каждого предупреждения, чтобы найти его переведенный вариант в переводе предупреждений по безопасности, прилагаемом к данному устройству.**

**СОХРАНИТЕ ЭТИ ИНСТРУКЦИИ**

**警告 重要的安全性说明**

**此警告符号代表危险。您正处于可能受到严重伤害的工作环境中。在您使用设备开始工作之前，必须充分意识到触电的危险，并熟练掌握防止事故发生的标准工作程序。请根据每项警告结尾提供的声明号码来找到此设备的安全性警告说明的翻译文本。**

**请保存这些安全性说明**

**警告** 安全上の重要な注意事項

「危険」の意味です。人身事故を予防するための注意事項が記述されています。装置の取り扱い作業を行うときは、電気回路の危険性に注意し、一般的な事故防止策に留意してください。警告の各国語版は、各注意事項の番号を基に、装置に付属の「Translated Safety Warnings」を参照してください。

これらの注意事項を保管しておいてください。

**주의** 중요 안전 지침

이 경고 기호는 위험을 나타냅니다. 작업자가 신체 부상을 일으킬 수 있는 위험한 환경에 있습니다. 장비에 작업을 수행하기 전에 전기 회로와 관련된 위험을 숙지하고 표준 작업 관례를 숙지하여 사고를 방지하십시오. 각 경고의 마지막 부분에 있는 경고문 번호를 참조하여 이 장치와 함께 제공되는 번역된 안전 경고문에서 해당 번역문을 찾으십시오.

이 지시 사항을 보관하십시오.

**تحذير****إرشادات الأمان الهامة**

يوضح رمز التحذير هذا وجود خطر. وهذا يعني أنك متواجد في مكان قد ينتج عنه التعرض لإصابات. قبل بدء العمل، احذر مخاطر التعرض للصدمات الكهربائية وكن على علم بالإجراءات القياسية للحيلولة دون وقوع أي حوادث. استخدم رقم البيان الموجود في آخر كل تحذير لتحديد مكان ترجمته داخل تحذيرات الأمان المترجمة التي تأتي مع الجهاز. قم بحفظ هذه الإرشادات

**Upozorenje** VAŽNE SIGURNOSNE NAPOMENE

Ovaj simbol upozorenja predstavlja opasnost. Nalazite se u situaciji koja može prouzročiti tjelesne ozljede. Prije rada s bilo kojim uređajem, morate razumjeti opasnosti vezane uz električne sklopove, te biti upoznati sa standardnim načinima izbjegavanja nesreća. U prevedenim sigurnosnim upozorenjima, priloženima uz uređaj, možete prema broju koji se nalazi uz pojedino upozorenje pronaći i njegov prijevod.

**SAČUVAJTE OVE UPUTE**

## Upozornění **DŮLEŽITÉ BEZPEČNOSTNÍ POKYNY**

**Tento upozorňující symbol označuje nebezpečí. Jste v situaci, která by mohla způsobit nebezpečí úrazu. Před prací na jakémkoliv vybavení si uvědomte nebezpečí související s elektrickými obvody a seznamte se se standardními opatřeními pro předcházení úrazům. Podle čísla na konci každého upozornění vyhledejte jeho překlad v přeložených bezpečnostních upozorněních, která jsou přiložena k zařízení.**

### **USCHOVEJTE TYTO POKYNY**

## Προειδοποίηση **ΣΗΜΑΝΤΙΚΕΣ ΟΔΗΓΙΕΣ ΑΣΦΑΛΕΙΑΣ**

Αυτό το προειδοποιητικό σύμβολο σημαίνει κίνδυνο. Βρίσκεστε σε κατάσταση που μπορεί να προκαλέσει τραυματισμό. Πριν εργαστείτε σε οποιοδήποτε εξοπλισμό, να έχετε υπόψη σας τους κινδύνους που σχετίζονται με τα ηλεκτρικά κυκλώματα και να έχετε εξοικειωθεί με τις συνήθεις πρακτικές για την αποφυγή ατυχημάτων. Χρησιμοποιήστε τον αριθμό δήλωσης που παρέχεται στο τέλος κάθε προειδοποίησης, για να εντοπίσετε τη μετάφρασή της στις μεταφρασμένες προειδοποιήσεις ασφαλείας που συνοδεύουν τη συσκευή.

### **ΦΥΛΑΞΤΕ ΑΥΤΕΣ ΤΙΣ ΟΔΗΓΙΕΣ**

## אזהרה

## **הוראות בטיחות חשובות**

סימן אזהרה זה מסמל סכנה. אתה נמצא במצב העלול לגרום לפציעה. לפני שתעבוד עם ציוד כלשהו, עליך להיות מודע לסכנות הכרוכות במעגלים חשמליים ולהכיר את הנהלים המקובלים למניעת תאונות. השתמש במספר ההוראה המסופק בסופה של כל אזהרה כדי לאתר את התרגום באזהרות הבטיחות המתורגמות שמצורפות להתקן.

## **שמור הוראות אלה**

**Opomena**      **ВАЖНИ БЕЗБЕДНОСНИ НАПАТСТВИЈА**  
 Символот за предупредување значи опасност. Се наоѓате во ситуација што може да предизвика телесни повреди. Пред да работите со опремата, бидете свесни за ризикот што постои кај електричните кола и треба да ги познавате стандардните постапки за спречување на несреќни случаи. Искористете го бројот на изјавата што се наоѓа на крајот на секое предупредување за да го најдете неговиот период во преведените безбедносни предупредувања што се испорачани со уредот.  
**ЧУВАЈТЕ ГИ ОБИЕ НАПАТСТВИЈА**

**Ostrzeżenie**      **WAŻNE INSTRUKCJE DOTYCZĄCE BEZPIECZEŃSTWA**

**Ten symbol ostrzeżenia oznacza niebezpieczeństwo. Zachodzi sytuacja, która może powodować obrażenia ciała. Przed przystąpieniem do prac przy urządzeniach należy zapoznać się z zagrożeniami związanymi z układami elektrycznymi oraz ze standardowymi środkami zapobiegania wypadkom. Na końcu każdego ostrzeżenia podano numer, na podstawie którego można odszukać tłumaczenie tego ostrzeżenia w dołączonym do urządzenia dokumencie z tłumaczeniami ostrzeżeń.**

**NINIEJSZE INSTRUKCJE NALEŻY ZACHOWAĆ**

**Upozornenie**      **DÔLEŽITÉ BEZPEČNOSTNÉ POKYNY**

**Tento varovný symbol označuje nebezpečenstvo. Nachádzate sa v situácii s nebezpečenstvom úrazu. Pred prácou na akomkoľvek vybavení si uvedomte nebezpečenstvo súvisiace s elektrickými obvodmi a oboznámte sa so štandardnými opatreniami na predchádzanie úrazom. Podľa čísla na konci každého upozornenia vyhľadajte jeho preklad v preložených bezpečnostných upozorneniach, ktoré sú priložené k zariadeniu.**

**USCHOVAJTE SI TENTO NÁVOD**



**Opozorilo      POMEMBNI VARNOSTNI NAPOTKI**

**Ta opozorilni simbol pomeni nevarnost. Nahajate se v situaciji, kjer lahko pride do telesnih poškodb. Preden pričnete z delom na napravi, se morate zavedati nevarnosti udara električnega toka, ter tudi poznati preventivne ukrepe za preprečevanje takšnih nevarnosti. Uporabite obrazložitevno številko na koncu posameznega opozorila, da najdete opis nevarnosti v priloženem varnostnem priročniku.**

**SHRANITE TE NAPOTKE!****警告****重要安全性指示**

此警告符號代表危險，表示可能造成人身傷害。使用任何設備前，請留心電路相關危險，並熟悉避免意外的標準作法。您可以使用每項警告後的聲明編號，查詢本裝置隨附之安全性警告譯文中的翻譯。  
請妥善保留此指示

## Obtaining Documentation and Submitting a Service Request

For information on obtaining documentation, submitting a service request, and gathering additional information, see the monthly *What's New in Cisco Product Documentation*, which also lists all new and revised Cisco technical documentation, at:

<http://www.cisco.com/en/US/docs/general/whatsnew/whatsnew.html>

Subscribe to the *What's New in Cisco Product Documentation* as a Really Simple Syndication (RSS) feed and set content to be delivered directly to your desktop using a reader application. The RSS feeds are a free service and Cisco currently supports RSS version 2.0.





# CHAPTER 1

## Product Overview

---

This chapter describes the Catalyst 4900 series switches, as well as system features and components.

This chapter contains these sections:

- Catalyst 4900 Series Switch Applications, page 1-2
- Catalyst 4948 Switch Software Features, page 1-3
- Catalyst 4948-10GE and Catalyst 4928-10GE Switch Software Features, page 1-4
- Hardware System Features, page 1-6
- Hardware System Features, page 1-6
- Switch Components, page 1-7

# Catalyst 4900 Series Switch Applications

The Catalyst 4900 series switches (see Figure 1-1, Figure 1-2, and Figure 1-3) are designed for high-performance, high-density edge switching applications. They are fixed configuration switching solutions delivering 10/100/1000 connectivity on all ports, supporting hot swappable, redundant power supplies in a compact one rack-unit size for applications where space is limited.

**Figure 1-1 Catalyst 4948 Switch**

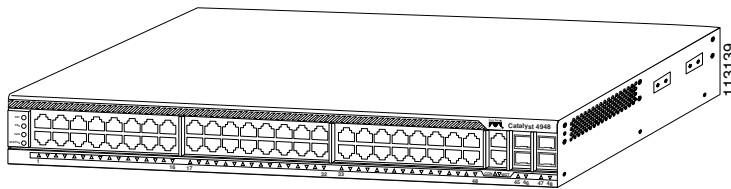

The Catalyst 4948 switch has a 96-Gbps, nonblocking, full-duplex switching fabric, providing 72 million packets-per-second of switching capacity for high-speed applications. The Catalyst 4948 chassis has 44 10BASE-T/100BASE-TX/1000BASE-T Ethernet ports and four ports that can be either 1000BASE-X SFP ports or 10BASE-T/100BASE-TX/1000BASE-T Ethernet ports.

**Figure 1-2 Catalyst 4948-10GE Switch**

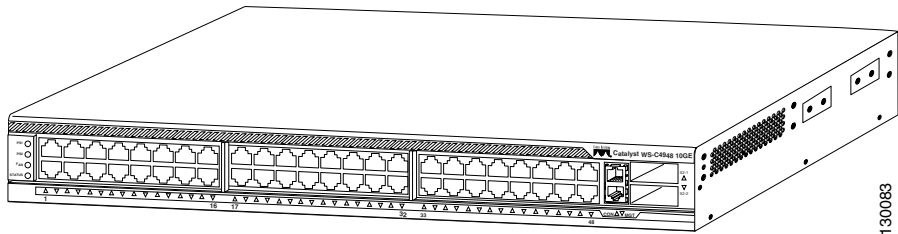

The Catalyst 4948-10GE switch has a 136-Gbps, nonblocking, full-duplex switching fabric, providing 102 million packets-per-second of switching capacity for high-speed applications. The Catalyst 4948-10GE chassis has 48 10/100/1000BASE-T Ethernet ports and two 10-Gigabit Ethernet uplink ports.

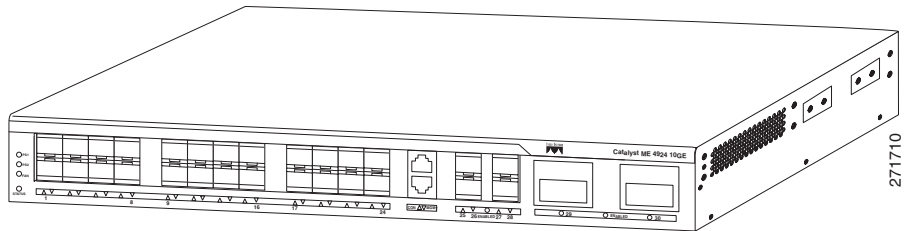
**Figure 1-3 Catalyst 4928-10GE Switch**

The Catalyst 4928-10GE switch has a 48-Gbps, nonblocking, full-duplex switching fabric, providing 102 million packets-per-second of switching capacity for high-speed applications. The Catalyst 4928-10GE chassis has 28 1000BASEX SFP ports, and two X2 10-Gigabit Ethernet uplink ports.

All three switches have a removable automatic variable speed fan tray for low noise operation at room temperature and removable and redundant 300 W AC or 300 W DC power supply provides fault-tolerance protection for the switch. See the “Connecting AC Power to the Switch” section on page 3-9.

## Catalyst 4948 Switch Software Features

The following is an overview of Catalyst 4948 features:

- Layer 2, Layer 3, and Layer 4 switching services
- Support for 32,768 MAC addresses for Layer 2 switching
- Support for 2,048 VLANs and 4,096 VLAN IDs
  - IEEE 802.1Q VLAN tagging on all ports
  - Q-in-Q for EFM
  - Cisco Inter Switch Link (ISL) tagging on all ports
- 16,000 multicast forwarding entries and 16,000 unicast forwarding entries
- 512 ingress policers and 512 egress policers
- 8,000 ingress Security ACEs (Access Control Entries) and 8,000 egress Security ACEs
- Support for port aggregation using Port Aggregation Protocol (PAgP) for Gigabit EtherChannel

- Catalyst 4500 series management software features include the following:
  - Command-line interface (CLI) and Simple Network Management Protocol (SNMP) interfaces consistent with the Catalyst 4500 series switches
  - Compatible development of new features with the Catalyst 4500 series switches
  - Support for out-of-band management over serial lines through a terminal attached to the console interface
  - Support for in-band management through any switch port through SNMP, Telnet client, and Trivial File Transfer Protocol (TFTP)
  - Remote Monitoring (RMON) with RMON-1
  - Support for standard Layer 2 features: 802.1D Spanning Tree, Cisco Discovery Protocol (CDP), VTP version 2 with pruning extensions, and Cisco Group Management Protocol (CGMP) client
- Embedded management features include the following:
  - Full SNMP instrumentation including entity-Management Information Base (MIB), all relevant standard MIBs, and all relevant Cisco MIBs
  - Support for the first four RMON groups (Ethernet Statistics, Alarms, Events, and History) on a per-port basis without the need for an optional RMON processing module
  - Performance management information
  - Embedded CiscoView support

## Catalyst 4948-10GE and Catalyst 4928-10GE Switch Software Features

The following is an overview of Catalyst 4948-10GE features:

- Layer 2, Layer 3, and Layer 4 switching services
- Support for 55,000 MAC addresses for Layer 2 switching
- Support for 4,096 VLANs and 4,096 VLAN IDs
  - IEEE 802.1Q VLAN tagging on all ports

- Q-in-Q for EFM
  - Cisco Inter Switch Link (ISL) tagging on all ports
- 16,000 multicast forwarding entries and 16,000 unicast forwarding entries
- 1022 ingress policers and 1022 egress policers
- 32,000 ingress Security ACEs and 32,000 egress Security ACEs
- Support for port aggregation using Port Aggregation Protocol (PAgP) for Gigabit EtherChannel
- Catalyst 4500 series management software features include the following:
  - Command-line interface (CLI) and Simple Network Management Protocol (SNMP) interfaces consistent with the Catalyst 4500 series switches
  - Compatible development of new features with the Catalyst 4500 series switches
  - Support for out-of-band management over serial lines through a terminal attached to the console interface
  - Support for in-band management through any switch port through SNMP, Telnet client, and Trivial File Transfer Protocol (TFTP)
  - Remote Monitoring (RMON) with RMON-1
  - Support for standard Layer 2 features: 802.1D Spanning Tree, Cisco Discovery Protocol (CDP), VTP version 2 with pruning extensions, and Cisco Group Management Protocol (CGMP) client
- Embedded management features include the following:
  - Full SNMP instrumentation including entity-Management Information Base (MIB), all relevant standard MIBs, and all relevant Cisco MIBs
  - Support for the first four RMON groups (Ethernet Statistics, Alarms, Events, and History) on a per-port basis without the need for an optional RMON processing module
  - Performance management information
  - Embedded CiscoView support

# Hardware System Features

The Catalyst 4900 series switches are high-performance dedicated Ethernet switches that fully integrate into the Catalyst family of switches using Catalyst 4500 series system software.

The following is an overview of the Catalyst 4900 series hardware features:

- (Catalyst 4948 and 4948-10GE) 48 10BASE-T/100BASE-TX/1000BASE-T Ethernet ports using RJ-45 interfaces. The following standards are supported:
  - IEEE 802.3 10BASE-T
  - IEEE 802.3u 100BASE-TX
  - IEEE 802.3z 1000BASE-X
  - IEEE 802.3x Pause and/or Full Duplex
  - IEEE 802.1Q
  - IEEE 802.3ab 1000BASE-T
  - IEEE 802.3ae
  - IEEE 802.1p
- (Catalyst 4948) Four 1000BASE-X Ethernet ports using SFP interfaces (These ports share MAC addresses with the last four 10BASE-T/100BASE-TX/1000BASE-T Ethernet ports.)
- (Catalyst 4928-10GE) 28 1000BASE-X Ethernet ports using SFP interfaces
- (Catalyst 4948-10GE and Catalyst 4928-10GE) Two 10-Gigabit Ethernet uplink ports using X2 interfaces
- Serial console management port using an RJ-45 interface
- A removable automatic variable speed fan tray for low noise (no more than 48 dB) operation at room temperature
- Redundant and removable 300 W AC or 300 W DC power supplies
- 256-MB SDRAM (fixed), 64-MB embedded Flash memory
- EtherChannel at 10/100/1000 Mbps (and 10 Gbps for the Catalyst 4948-10GE and Catalyst 4928-10GE)
- Hardware-based access lists
- Storm control in hardware



# Switch Components

This section describes the hardware components.

## Traffic Ports on the Catalyst 4948

There are 48 10/100/1000BASE-T Ethernet ports using RJ-45 interfaces and four 1000BASE-X Ethernet ports using SFP interfaces. These SFP ports share MAC addresses with the last four 10/100/1000BASE-T ports. The interface configuration mode command **media-type sfp | rj45** can be used to configure the media type for these ports in the switch software and to determine whether the SFP connector or the RJ-45 connector is used. The default is SFP.

## Traffic Ports on the Catalyst 4948-10GE

There are 48 10/100/1000BASE-T Ethernet ports using RJ-45 interfaces and two 10-Gigabit Ethernet uplink ports using X2 interfaces.

## Traffic Ports on the Catalyst 4928-10GE

There are 28 1000BASE-X Ethernet ports using SFP interfaces.

## Console Port

A console serial port (RJ-45) provides for switch management using standard console equipment. (See Figure 1-4.) A connector pinout table is provided in Appendix A, “Specifications,” for the console and management ports.

The Management port on the front panel is only operational when the switch is in rommon mode. When in use, it offers the same TCP/IP based management services available using inband access (Telnet, SNMP, etc.). IP address configuration using BOOTP is supported on the Management port; it also supports image download to the switch.

Figure 1-4 and Figure 1-5 show the location of the management and console ports on the switches.

**Figure 1-4** (Catalyst 4948) Management Port LEDs Detailed View

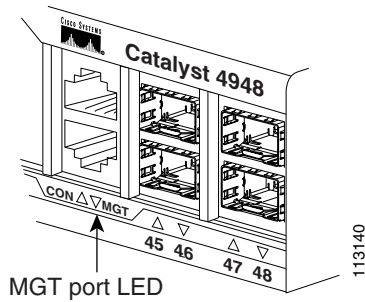

**Figure 1-5** (Catalyst 4948-10GE) Management Port LEDs Detailed View

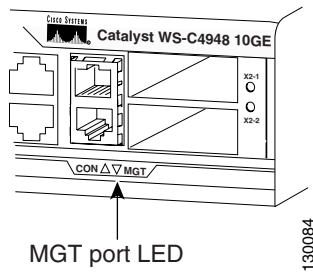

**Figure 1-6** (Catalyst 4928-10GE) Management Port Detailed View

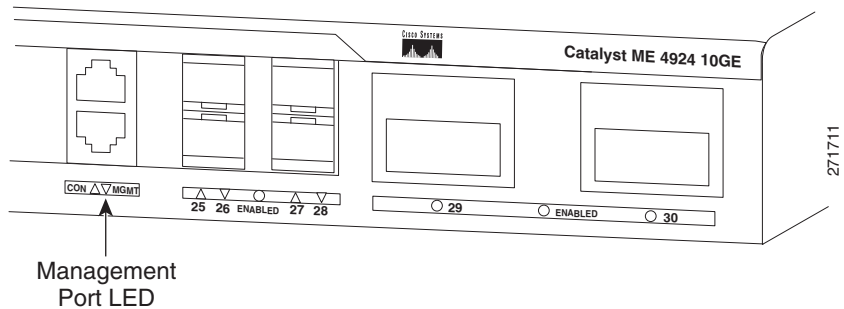

## Front Panel LEDs

The LEDs on the front panel of the switch (see Figure 1-4 and Figure 1-7) provide status information as follows:

**Figure 1-7 Detailed View of the STATUS LEDs**

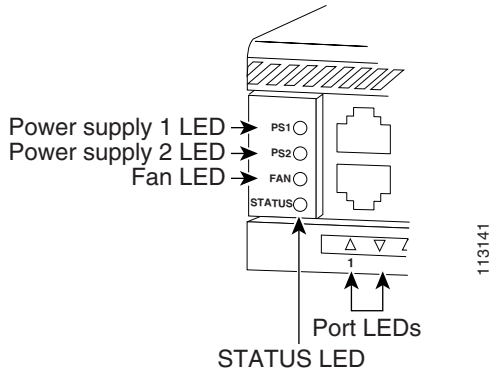

- STATUS LED indicates the operating state of the switch.
- PS1 LED indicates the internal power supply status.
- PS2 LED indicates the internal power supply status.
- FAN LED indicates the fan tray status.
- A link status LED is below the management port.

Table 1-1 describes LED functions.

**Table 1-1 LED Functions**

LED	Color or State	Description
STATUS	Green	At startup, the switch performs a series of diagnostic tests: All tests pass
	Red	A test other than an individual port test fails
	Flashing	System boot or diagnostic tests in progress
	Yellow	System is in rommon mode or a power supply has failed
	Off	Switch is disabled
CON	Green	10/100 BASE-T console port is in link-up state
	Off	10/100 BASE-T console port is in link-down state or not connected  There are no blinking, red, or yellow states for this port
MGT	Green	10/100 BASE-T Management port is in link-up state
	Off	10/100 BASE-T Management port is in link-down state or not connected  There are no blinking, red, or yellow states for this port
Port 1-48	Green	Port is operational
	Yellow	Port is disabled by user
	Flashing yellow	Power-on self-test indicates faulty port
	Off	No signal detected or link configuration failure

**Table 1-1 LED Functions (continued)**

LED	Color or State	Description
FAN	Off	No power to the switch or fans (the tray may not be plugged in especially if one or more of the power supplies status LED is green)
	Green	Fan tray operational
	Red	Fault detected
PS1 and PS2	Off	No power to the PS
	Green	Operational <sup>1</sup>
	Red	Fault detected or the on/off switch is set to off while the power supply is plugged in

1. If either LED is green and the other is OFF the power supply is probably not plugged in. If it is red, the supply is either plugged in and not switched on or it is faulty. It may be necessary to use the CLI for further status information.

## Chassis Cooling



### Note

For environmental specifications, see Chapter 2, “Site Planning.”

The hot-swappable system fan tray provides cooling air for the internal chassis components. The fans exhaust air to the rear, and fresh air is drawn in from the sides of the chassis.



### Caution

When the fan tray is removed, internal circuitry is exposed that should not be touched by tools or fingers. The system should not be left operating without a fan tray for longer than is necessary to replace a faulty fan tray with a new one.

Figure 1-8 shows the direction of airflow going in and out of the switch.

**Figure 1-8** Airflow (Catalyst 4948-10GE shown)

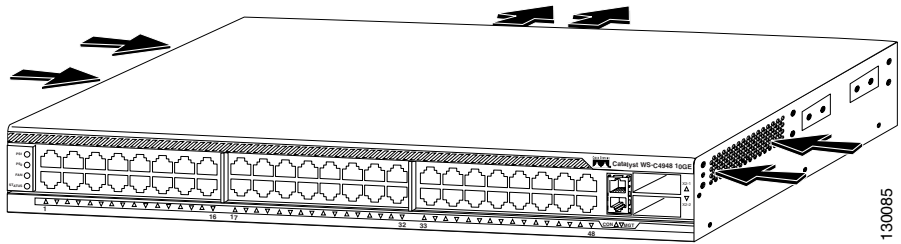

There are four fans in the fan tray. If an individual fan fails, the other fans continue to run. Sensors monitor the internal air temperatures. The number of fans in operation and their speed varies according to the internal temperature for the quietest operation possible. If the air temperature exceeds a desired threshold, the environmental monitor displays warning messages.

## Power Supplies



### Note

For complete power specifications for the switch, see Appendix A, “Specifications.”

The Catalyst 4900 series switches have two redundant internal 300 W AC or 300 W DC power supplies.

The internal power supplies have individual power cords and status LEDs (PS1 and PS2 on the front panel). There are also LEDs on the power supplies that show status for the input (Input OK) and output (Output OK) currents. A power cord is used to connect the power supplies to the site power source. There is a power switch on the AC power supplies; AC power is present when a power cord is plugged into a power supply and the switch is set to the On position. DC power supplies do not have an on/off switch and do not provide a cable for connection to a DC power source.

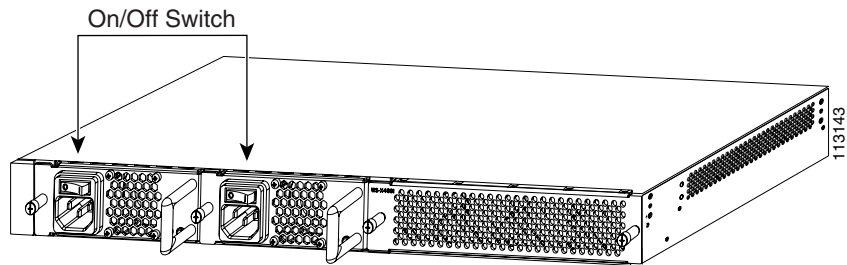
**Figure 1-9 On/Off Switch Locations**

The switch will start with only one power supply plugged in, but redundant failover and load sharing will not be available in this configuration. We recommend that you always connect both power supplies to separate AC or DC circuits for optimal power reliability.

For safety reasons, the AC power supply needs to be switched off and unplugged before it is removed from a chassis or inserted into a chassis. DC supplies should have power shut off from the source before they are removed.

If only one power supply will be used, you must use the blank faceplate supplied to cover the empty power bay.

## Environmental Monitoring of the Power Supplies

Using the environmental monitoring and reporting functions, you can maintain normal system operation by resolving adverse environmental conditions prior to loss of operation.

Each power supply monitors its own temperature and output voltages. The switch senses the operating condition of the power supply and reports status through software.

## Power Management for the Switch

You can choose AC or DC power supplies for your switch. The Catalyst 4900 series switches support the following power supplies:

- 300 W AC
- 300 W DC

A redundant power supply can be identified and diagnosed by a running system regardless of its input status. AC and DC supplies are interchangeable.

## Power Management Modes

Catalyst 4900 series switches support the redundant power management mode. In this mode, if both power supplies are operating normally, each provides from 20/80 to 45/55 percent of the total system power requirements at all times. If one power supply fails, the other unit increases power to 100 percent of the total power requirement.





## CHAPTER 2

# Site Planning

---

This chapter describes how to prepare your site for installation of the switch and contains these sections:

- Site Environmental Requirements, page 2-1
- Site Power Requirements, page 2-2
- Grounding Requirements, page 2-6
- Safety Overview, page 2-7
- Site Planning Checklist, page 2-9

For detailed information about cabling requirements, see Chapter 4, “Transceiver Modules.”



### Note

---

A site planning checklist is provided on page 3-5 to help ensure that you complete all site planning activities before you install the switch.

---

## Site Environmental Requirements

Planning a proper location for the switch and layout for your equipment rack or wiring closet is essential for successful system operation. You should install the switch in an enclosed, secure area, ensuring that only qualified personnel have access to the switch and control of the environment. Equipment that is placed too closely together or that is inadequately ventilated can cause system overtemperature conditions. In addition, poor equipment placement can make chassis panels inaccessible and difficult to maintain.

The switch operates as a standalone system mounted in a rack in a secure wiring closet. It requires a dry, clean, well-ventilated, and air-conditioned environment. To ensure normal operation, maintain ambient airflow. If the airflow is blocked or restricted, or if the intake air is too warm, an overtemperature condition can occur. The switch environmental monitor can then shut down the system to protect the system components.

To ensure normal operation and avoid unnecessary maintenance, plan your site configuration and prepare your site *before* installation. After installation, make sure that the site maintains an ambient temperature of 0 to 40° C (32 to 104° F). It is essential to keep the area around the chassis as free from dust and foreign conductive material (such as metal flakes from nearby construction activity) as is possible.

Multiple switches can be rack-mounted with little or no clearance above and below the chassis. However, when mounting a switch in a rack with other equipment, or when placing it on the floor near other equipment, ensure that the exhaust from other equipment does not blow into the intake vents of the chassis.

Cooling air is drawn in through the sides and exhausted through the rear of the chassis. Keep the sides and rear clear of obstructions, including dust and foreign conductive material, and away from the exhaust ports of other equipment.

Appendix A, “Specifications,” lists the operating and nonoperating environmental site requirements for the switches. To maintain normal operation and ensure high system availability, maintain an ambient temperature and EMI-free and continuous power at your site. The environmental ranges listed in Appendix A are those within which the switch will continue to operate; however, a measurement that approaches the minimum or maximum of a range indicates a potential problem. You can maintain normal operation by anticipating and correcting environmental anomalies before they exceed the maximum operating range.

## Site Power Requirements

This section describes the installation site power requirements for the switch. Verify your site power before you install the switch.

This section consists of the following sections:

- Pre-installation Requirements, page 2-3
- Warnings and Cautions, page 2-3

- EMI Recommendations, page 2-4
- Power Requirements and Heat Dissipation, page 2-4

## Pre-installation Requirements

Follow these requirements when preparing your site for the switch installation:

- Connect each switch to separate wiring on a dedicated circuit; provide each switch with its own branch circuit connection with sufficient overcurrent protection and direct grounding to the branch circuit.
- To prevent a loss of input power, be sure the total maximum load on each AC circuit is within the current ratings of the wiring and breakers.

## Warnings and Cautions

Follow these precautions when preparing your site for the switch installation:



---

The total maximum load on each AC-input power circuit must be within the rating of the wiring and breaker. An overload of input power can result if this requirement is not met.

---



---

**Read the installation instructions before connecting the system to the power source.** Statement 1004

---



---

**Installation of the equipment must comply with local and national electrical codes.** Statement 1074

---



---

**Ultimate disposal of this product should be handled according to all national laws and regulations.** Statement 1040

---

## EMI Recommendations

Follow these guidelines when setting up the site wiring. When planning the location of the new system, consider electromagnetic interface (EMI), the distance limitations for signaling, and connector compatibility.

When wires are run for any significant distance in an electromagnetic field, radio frequency interference (RFI) can occur between the field and the signals on the wires.

- Bad plant wiring can result in radio frequency interference.
- Strong EMI, especially when caused by lightning or radio transmitters, can destroy the signal drivers and receivers in the switch and can create an electrical hazard by conducting power surges through lines and into equipment.

**Note**

---

To predict and remedy strong EMI, you might need to consult RFI experts.

---

## Power Requirements and Heat Dissipation

The power requirements might be useful for planning the power distribution system needed to support the switches. Heat dissipation is an important consideration for sizing the air-conditioning requirements for an installation. Refer to Appendix A, “Specifications,” for the power and heat ratings for a switch.

You will also need to provide power to the switch with the appropriate AC power cord for your location. Table 2-1 lists the power cords that are used with the AC power supply.

**Table 2-1 AC-Input Power Cord Options**



Locale	Part Number	Length	Plug Rating	Plug Type
<b>300 W AC Power Supply</b>			<b>Appliance Coupler</b>	 120352
North America	CAB-US515-C15-US= (was CAB-7KAC=)	8.2 ft (2.5 m)	125 VAC, 15 A	NEMA 5-15P  120354
	CAB	13.2 ft (4.0 m)	250 VAC, 16 A	NEMA 6-20 non-locking  120355
	CAB	13.6 ft (4.1 m)	250 VAC, 16 A	NEMA L6-20  120361
Australia, New Zealand	CAB-AS3112-C15-AU= (was CAB-7ACA=)	8.2 ft (2.5 m)	250 VAC, 15 A	SAA/3, AS/NZS 3112-1993  120356
Europe (except Italy)	CAB-CEE77-C15-EU= (was CAB-7ACE=)	8.2 ft (2.5 m)	250 VAC, 16 A	CEE 7/7  120357

Table 2-1 AC-Input Power Cord Options (continued)

Locale	Part Number	Length	Plug Rating	Plug Type
Italy	CAB-C2316-C15-IT= (was CAB-7ACI=)	8.2 ft (2.5 m)	250 VAC, 16 A	1/3/16 CEI 23-16  120358
United Kingdom	CAB-BS1363-C15-UK= (was CAB-7ACU=)	8.2 ft (2.5 m)	250 VAC, 13 A	BS 89/13 BS 1363/A  120359
Argentina	CAB-IR2073-C15-AR= (was CAB-7KACR=)	8.2 ft (2.5 m)	250 VAC, 10 A	IRAM 2073  120356
South Africa, India	CAB-BS546-C15-SA= (was CAB-7KACSA=)	8.2 ft (2.5 m)	250 VAC, 10 A	BS 546  203795

## Grounding Requirements

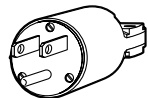
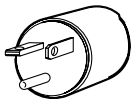
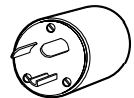
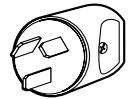
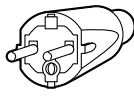
Grounding is recommended on all AC or DC installations, using only approved copper connectors. Attach the provided two hole ground lug to the chassis using M4x 8mm bolts and then to the central office (CO) or other interior ground system with number 6 AWG wire. The grounding connectors are on the right side of the chassis, and either one may be used. (See Figure 2-1.)

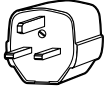
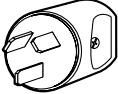
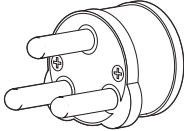
**Figure 2-1** Grounding Pad Locations (Catalyst 4849-10GE shown)

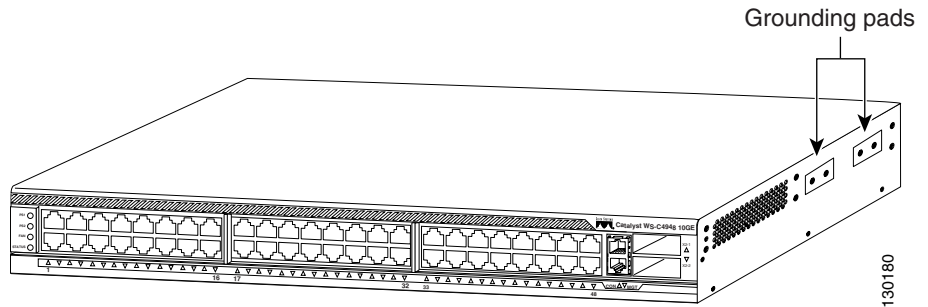

## Safety Overview

This section provides safety information that you should read and understand to ensure a safe switch installation.

## Ensuring Safety

Follow these guidelines to ensure your safety and protect the equipment. This list is not inclusive of all potentially hazardous situations that you may be exposed to as you install the switch, so be alert.



**Warning**

**Only trained and qualified personnel should be allowed to install, replace, or service this equipment.** Statement 1030



**Warning**

**The plug-socket combination must be accessible at all times, because it serves as the main disconnecting device.** Statement 1019

**Warning**

**This equipment must be grounded. Never defeat the ground conductor or operate the equipment in the absence of a suitably installed ground conductor. Contact the appropriate electrical inspection authority or an electrician if you are uncertain that suitable grounding is available.** Statement 1024

**Note**

To completely de-energize the system, unplug the power cord.

- Always use caution when lifting heavy equipment. See the “Lifting the Chassis Safely” section on page 3-5 before lifting the switch.
- Always turn all power supplies off by unplugging all power cords before installing or removing a chassis.
- Keep the chassis area clear and free of dust during and after installation.
- Keep tools and chassis components off of the floor and away from foot traffic.
- Avoid wearing jewelry (including rings and chains) or other items that could get caught in the chassis. Avoid wearing any loose clothing, or securely fasten items such as ties, scarves, or sleeves.
- Install the system in compliance with the following local and national electrical codes:
  - United States—National Fire Protection Association (NFPA 70); United States National Electrical Code
  - Canada—Canadian Electrical Code, Part I, CSA C22.1
  - Other countries—International Electrotechnical Commission (IEC) 60364, Part 1 through Part 7

## Working Safely with Electricity

Follow these basic guidelines when working with any electrical equipment:

- Locate the emergency power-off switch for the room in which you are working before beginning installation.
- Disconnect all power and external cables before installing or removing a chassis.



- Do not work alone when potentially hazardous conditions exist.
- Never assume that power has been disconnected from a circuit; always check.
- Do not perform any action that creates a potential hazard to people or makes the equipment unsafe.
- Examine your work area carefully for possible hazards such as moist floors, ungrounded power extension cables, and missing safety grounds.

## Preventing Electrostatic Discharge Damage

Electrostatic discharge (ESD) damage occurs when electronic cards or components are improperly handled and can result in complete or intermittent failures. Follow these guidelines to prevent ESD damage:

- Always use an ESD-preventive wrist or ankle strap, and ensure that it makes maximum contact with the skin.
- When coming into contact with any internal components, always use a wrist strap connected to one of the following:
  - ESD wrist strap connector
  - Any unpainted grounded surface on the chassis or equipment rack



### Caution

---

Periodically check the resistance value of the antistatic strap. The measurement should be between 1 and 10 megohms (Mohms).

---

- Handle cards by the edges only.
- Avoid contact between the modules and clothing. The wrist strap protects only the card from ESD voltages on the body; ESD voltages on clothing can still cause damage.

## Site Planning Checklist

Table 2-2 lists the site planning activities that you should perform before you install the switch. Completing each activity helps to ensure a successful switch installation.

**Table 2-2 Site Planning Checklist**

<b>Task No.</b>	<b>Planning Activity</b>	<b>Verified By</b>	<b>Time</b>	<b>Date</b>
1	Space evaluation: Space and layout Floor covering Shock and vibration Lighting Maintenance access			
2	Environmental evaluation: Ambient temperature Humidity Altitude Atmospheric contamination Airflow			
3	Power evaluation: Input power type Receptacle proximity to the equipment Dedicated (separate) circuits for redundant power supplies UPS for power failures			
4	Grounding evaluation: Circuit breaker size			
5	Cable and interface equipment evaluation: Cable type Connector type Cable distance limitations Interface equipment (transceivers)			
6	EMI evaluation: Distance limitations for signaling Site wiring RFI levels			



# CHAPTER 3

## Installing the Switch

---

This chapter describes how to install the Catalyst 4900 series switch. For first-time installations, perform the procedures in the following sections in the order listed.

- Verifying the Contents, page 3-1
- Rack-Mounting the Switch, page 3-2
- Connecting AC Power to the Switch, page 3-9
- Connecting DC Power to the Switch, page 3-11



### Note

---

Before starting the installation procedures in this chapter, complete the site planning checklist in Chapter 2, “Site Planning,” to verify that all planning activities were completed.

---

## Verifying the Contents



### Note

---

Do not discard the shipping container when you unpack the switch. Flatten the shipping cartons and store them. You will need the container if you need to move or ship the switch in the future.

---

To verify the contents of the shipping container follow these steps:

- 
- Step 1** Compare the contents of the accessories kit to the packing slip. Verify that you received all listed equipment, which should include the following:
- Switch hardware and software documentation, if ordered
  - Optional equipment that you ordered, such as network interface cables, transceivers, or special connectors
- Step 2** To begin installation, proceed to the “Rack-Mounting the Switch” section on page 3-2.
- 

## Rack-Mounting the Switch

A standard rack-mount kit is included for mounting the switch in a standard 19-inch (48.3 cm) equipment rack. A standard equipment rack has two unobstructed outer posts, a minimum depth between the front and rear mounting posts of 19.25 inches (48.9 cm), and a maximum depth of 32 inches (81.3 cm). This kit is not suitable for racks with obstructions (such as a power strip) that could impair access to the switch.



---

**Caution**

Before installing the chassis in a rack, read the “Site Environmental Requirements” section on page 2-1 to familiarize yourself with the proper site and environmental conditions. Failure to read and follow these guidelines could lead to an unsuccessful installation and possible damage to the system and components.

---



---

**Caution**

This unit is meant to be rack-mounted, and is not intended to bear more than its own weight. Do not stack more than two on a table top, the added weight may damage the bottom chassis.

---

**Warning**

**To prevent bodily injury when mounting or servicing this unit in a rack, you must take special precautions to ensure that the system remains stable. The following guidelines are provided to ensure your safety:**

- **This unit should be mounted at the bottom of the rack if it is the only unit in the rack.**
- **When mounting this unit in a partially filled rack, load the rack from the bottom to the top with the heaviest component at the bottom of the rack.**
- **If the rack is provided with stabilizing devices, install the stabilizers before mounting or servicing the unit in the rack.** Statement 1006

## Rack-Mounting Guidelines

Before rack-mounting the switch, ensure the following:

- The equipment rack is the proper size.
  - The width of the rack, between the two front mounting strips or rails, must be 17.75 inches (45.09 cm).
  - The depth of the rack, between the front and rear mounting strips, must be at least 19.25 inches (48.9 cm) but not more than 32 inches (81.3 cm).
  - The rack must have sufficient vertical clearance to insert the chassis. The chassis height is 1.75 inches (4.45 cm).
- The equipment rack is stable and in no danger of falling over.
  - Ensure that the shelf is constructed to support the weight and dimensions of the chassis. For physical specifications, see Appendix A, “Specifications.”
  - We recommend that you bolt the rack to the floor.
  - Mount the unit at the bottom of the rack if it is the only unit in the rack.
  - Install heavier equipment in the lower half of the rack to maintain a low center of gravity and prevent the rack from becoming top-heavy and tipping over.

- Install the stabilizers before mounting or servicing the switch in the rack (if the rack is provided with stabilizing devices).
- The equipment rack is properly ventilated.
  - Install the chassis in an enclosed rack only if it has adequate ventilation or an exhaust fan; use an open rack whenever possible.
  - Ensure that the ambient temperature of the rack environment does not exceed a maximum temperature of 104° F (40° C). Note that if the switch is installed in a closed or multiunit rack assembly, the ambient operating temperature of the rack environment might be higher than the ambient room temperature.
  - Note that a ventilation system in a closed rack that is too powerful might also prevent cooling by creating negative pressure around the chassis and redirecting the air away from the chassis intake vent. If necessary, operate the chassis with the rack open.
  - To prevent airflow restriction, allow at least 3 inches (7.6 cm) of clearance around the ventilation openings on the sides of the chassis.
  - Use baffles correctly to assist in cooling the chassis.
  - Note that equipment near the bottom of a rack may generate excessive heat that is drawn upward and into the intake ports of equipment above, leading to overtemperature conditions in the chassis at or near the top of the rack.
  - Consider the equipment and cabling that is already installed in the rack. Ensure that cables from other equipment will not obstruct the airflow through the chassis or impair access to the power supplies or switching modules. Route cables away from field-replaceable components to avoid disconnecting cables unnecessarily for equipment maintenance or upgrades.
  - Allow at least 3 to 4 feet (91.4 to 121.9 cm) of clearance behind the rack for maintenance and removal of switch assemblies. If the rack is mobile, you can push it back within 1 foot (30.45 cm) of a wall or cabinet for normal operation and pull it out when necessary for maintenance.

## Lifting the Chassis Safely

The chassis is not intended to be moved frequently. Before you install the switch, ensure that your site is properly prepared so that you can avoid moving the chassis later to accommodate power sources and network connections.

Whenever you lift a chassis or any heavy object, follow these guidelines:

- Ensure that your footing is solid, and balance the weight of the chassis between your feet.
- Lift the chassis slowly; never move suddenly or twist your body as you lift.
- Keep your back straight and lift with your legs, not your back. If you must bend down to lift the chassis, bend at the knees, not at the waist, to reduce the strain on your lower back muscles. (See Figure 3-1.)
- Always disconnect all external cables before lifting or moving the chassis.

**Figure 3-1** *Unsafe Lifting Practices*



## Required Installation Tools

The following tools and equipment are required to install the chassis:

- Number 1, number 2 Phillips, and 3/16-inch flat-blade screwdriver
- Antistatic mat or antistatic foam

- Your own ESD grounding strap or the disposable ESD strap included with the system

The following tools and equipment are required to install the chassis in a rack:

- Rack-mount kit
- Tape measure and level

## Rack-Mounting the Switch



### Note

The illustrations shown are of a Catalyst 4948-10GE switch. The process for the Catalyst 4948 and Catalyst 4928-10GE is identical.

Follow these steps to install the switch in a rack.

### Step 1

Prepare for installation:

- Place the chassis on the floor or on a sturdy table as close as possible to the rack. Leave enough clearance to allow you to move around the chassis.
- Use a tape measure to measure the depth of the rack. Measure from the outside of the front mounting posts to the outside of the rear mounting strip. The depth must be at least 19.25 inches (48.9 cm) but not greater than 32 inches (81.3 cm).
- Measure the space between the inner edges of the left front and right front mounting posts to ensure that it is 17.75 inches (45.09 cm) wide. (The chassis is 17.5 inches [44 cm] wide and must fit between the mounting posts.)
- Open the rack-mount kit, and refer to Table 3-1 to verify that all parts are included.

**Table 3-1** *Rack-Mount Kit Checklist*

Quantity	Part Description	Received
2	L brackets	
8	M4 x 8 mm Phillips flat-head screws	



**Table 3-1** *Rack-Mount Kit Checklist*

Quantity	Part Description	Received
4	12-24 x 3/4-inch Phillips binder-head screws	
4	10-32 x 3/4-inch Phillips binder-head screws	



**Note** Figure 3-2 illustrates how to attach the front of the switch to the rack. You can also attach the rear of the switch to the rack, depending on the configuration of your rack.

**Step 2** Note that the L brackets connect the chassis to the rack. You can mount the L brackets to the front or rear mounting holes of the chassis, depending on which end is in the front of the rack.



**Note** Some equipment racks provide a power strip along the length of one of the rear posts. If the rack has this feature, consider the position of the strip when planning fastener points. Before installing the L brackets on the chassis, determine whether to install the chassis from the front or the rear of the rack.

Attach the left and right L brackets using the M4 Phillips flat-head screws provided in the rack-mount kit. (See Figure 3-2.)

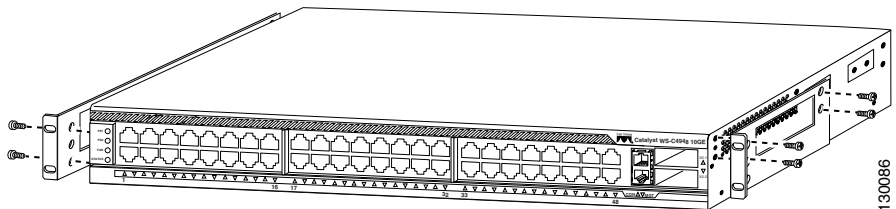
**Figure 3-2** *Attaching the L Brackets to the Switch*

**Step 3** Install the chassis in the rack as:

- a. Position the chassis in the rack as follows (see Figure 3-3):

- If the chassis front panel is in the front of the rack, insert the rear of the chassis between the mounting posts.
  - If the rear of the chassis is in the front of the rack, insert the front of the chassis between the mounting posts.
- b. Align the mounting holes in the L bracket with the mounting holes in the equipment rack.
  - c. Secure the chassis using four (two on each side) 12-24 x 3/4-inch screws through the elongated holes in the L bracket and into the threaded holes in the mounting post.
  - d. Use a tape measure and level to ensure that the chassis is installed straight and level.

**Figure 3-3** Installing the Switch in the Rack

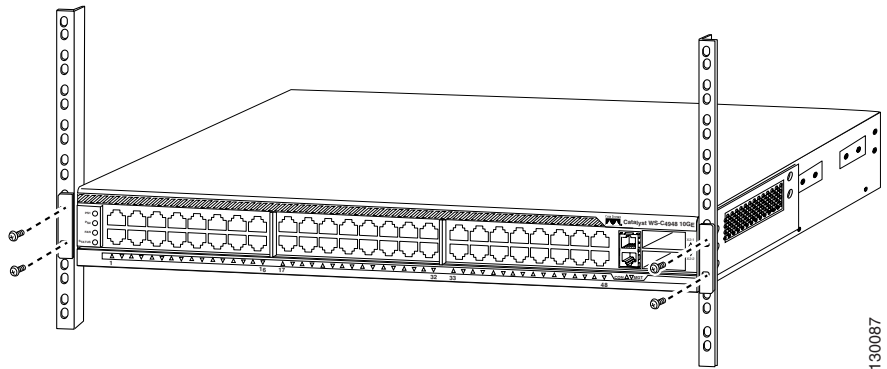

- Step 4** Attach the cable guide to the right or left side of the chassis mount.

**Figure 3-4** Installing the Cable Guide

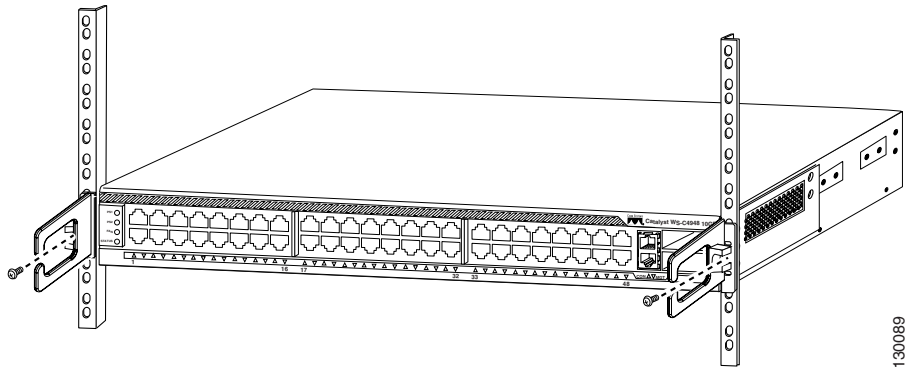

- Step 5** Do not connect the power cord at this time. Proceed to the “Connecting AC Power to the Switch” section on page 3-9.

## Connecting AC Power to the Switch

Follow these steps and warnings when connecting power to a Catalyst 4900 series switch:

- Step 1** Prior to connecting the power supply to a power source, ensure that all of the site power and grounding requirements described in Chapter 2, “Site Planning,” have been met and the chassis is properly grounded as described in the “Grounding Requirements” section on page 2-6.



### Warning

**The plug-socket combination must be accessible at all times, because it serves as the main disconnecting device.** Statement 1019

- Step 2** Plug the power cords into the power supplies. (Figure 3-6 shows plug locations.)

Figure 3-5 AC Power Supply

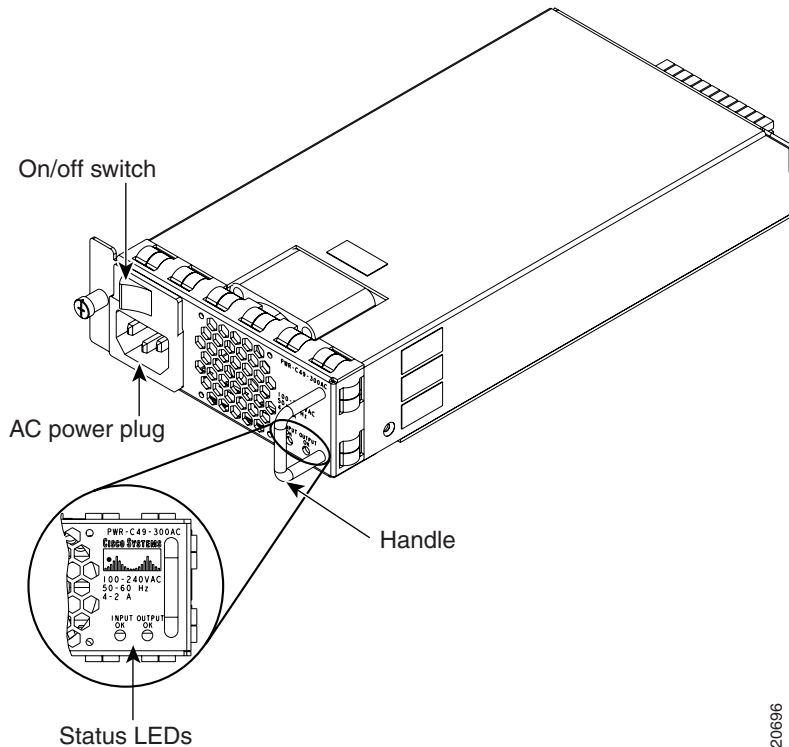

120696

- Step 3** Connect the other end of the power cords to an AC-power input source. If both power supplies will be used, make sure they are on different circuits.
- Step 4** Turn the power switches to the ON position.
- Step 5** Verify power supply operation by looking at the front panel power supply LEDs:
- The PS1 or PS2 LED is green when the power supply and fans are functioning normally.
  - The PS1 or PS2 LED is red when the power supply is not functioning normally. The on/off switch may be set to off while the power supply is plugged in, or the power supply may be defective and not providing DC power to the switch. There may also be a fan failure.
  - The PS1 or PS2 LED is off when there is no power supply installed.

From the system console, enter the **show power** command to display the power supply and system status. For more information on this command, see the command reference publication for your software release.

If the LEDs or **show power** command indicate a power or other system problem, see Chapter 5, “Troubleshooting the Installation,” for troubleshooting information.

---

## Connecting DC Power to the Switch

Follow these steps and warnings when connecting DC power to the Catalyst 4900 series switch:



**Warning**

---

**Before performing any of the following procedures, ensure that power is removed from the DC circuit.** Statement 1003

---



**Warning**

---

**This unit is intended for installation in restricted access areas. A restricted access area can be accessed only through the use of a special tool, lock and key, or other means of security.** Statement 1017

---



**Warning**

---

**This product requires short-circuit (overcurrent) protection, to be provided as part of the building installation. Install only in accordance with national and local wiring regulations.** Statement 1045

---



**Warning**

---

**Hazardous voltage or energy may be present on DC power terminals. Always replace cover when terminals are not in service. Be sure uninsulated conductors are not accessible when cover is in place.** Statement 1075

---

- Step 1** Prior to connecting the power supply to a power source, ensure that all of the site power and grounding requirements described in Chapter 2, “Site Planning,” have been met and the chassis is properly grounded as described in the “Grounding Requirements” section on page 2-6.
- Step 2** Remove the safety cover from the power terminal.
- Step 3** Connect the power supply ground terminal to earth ground.

**Figure 3-6 DC Power Supply**

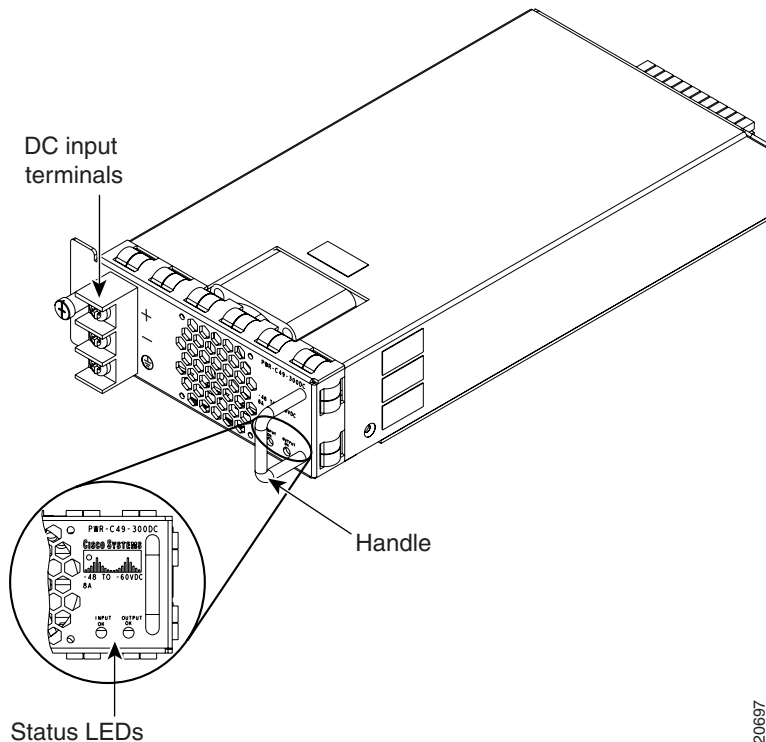

- Step 4** Connect the positive and negative power cables into the power supplies using a number 2 Phillips screwdriver.



**Note** The DC power cables may use AWG #10 to AWG #12 wire.

- Step 5** Replace the safety cover over the power terminals.
- Step 6** Connect the other end of the power cables to an DC-power input source. If both power supplies will be used, make sure they are on different circuits.
- Step 7** Turn on the power from the power source. The DC supply does not have an on/off switch.
- Step 8** Verify power supply operation by looking at the front panel power supply LEDs:
- The PS1 or PS2 LED is green when the power supply is functioning normally.
  - The PS1 or PS2 LED is red when the power supply is not functioning normally.
  - The PS1 or PS2 LED is off when the power supply is not connected to a power source.

From the system console, enter the **show power** command to display the power supply and system status. For more information on this command, see the command reference publication for your software release.

If the LEDs or **show power** command indicate a power or other system problem, see Chapter 5, “Troubleshooting the Installation,” for troubleshooting information.

---







## CHAPTER 4

# Transceiver Modules

---

This chapter tells you where to find instructions for installing SFP modules and X2 modules, which are laser optical transceivers used for Ethernet connections. Where needed, notes applying specifically to these switches are provided.

## SFP Modules

To install SFP Modules, refer to the *Cisco Small Form-Factor Pluggable Modules Installation Note* at the following location:

[http://www.cisco.com/en/US/products/hw/modules/ps5455/prod\\_installation\\_guide09186a00803aa0da.html](http://www.cisco.com/en/US/products/hw/modules/ps5455/prod_installation_guide09186a00803aa0da.html)

To get the latest information on SFP compatibility, refer to the relevant documents at the following location:

[http://www.cisco.com/en/US/products/hw/modules/ps5455/products\\_device\\_support\\_tables\\_list.html](http://www.cisco.com/en/US/products/hw/modules/ps5455/products_device_support_tables_list.html)

## SFP Modules and Alternative Wiring

The Catalyst 4948 switches have four ports that can be configured with any combination of SFP modules with LC connectors, as shown in Figure 4-2. The interface configuration mode command **media-type sfp | rj45** can be used to configure the media type for these ports in the switch software and determines whether the SFP or the RJ-45 connector is used. The default is SFP.

**Note**

You must insert the SFP with the latching mechanism reversed on SFP port 46 and port 48.

**Figure 4-1** Connecting LC Connectors to the SFP Module (Catalyst 4948)

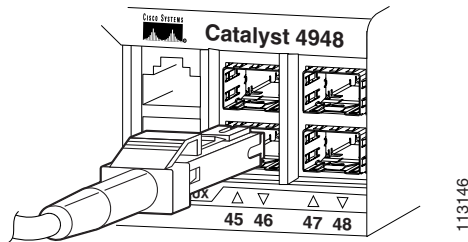

## X2 Modules

You must connect the cables and install the X2 modules as shown in Figure 4-2 and Figure 4-3. More general installation information is in the *10-Gigabit Ethernet X2 Transceiver Installation Note* at the following location:  
[http://www.cisco.com/en/US/products/hw/modules/ps5455/prod\\_installation\\_guide09186a00803469ed.html](http://www.cisco.com/en/US/products/hw/modules/ps5455/prod_installation_guide09186a00803469ed.html)

For compatibility information, refer to the *10-Gigabit Ethernet Transceiver Modules Compatibility Matrix* at the following location:

[http://www.cisco.com/en/US/products/hw/modules/ps5455/products\\_device\\_support\\_table09186a00803857e7.html](http://www.cisco.com/en/US/products/hw/modules/ps5455/products_device_support_table09186a00803857e7.html)

**Figure 4-2** Connecting SC Connectors to the X2 Module

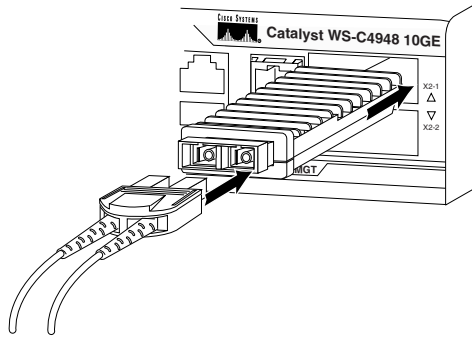

If a module designed for operation on an SMF cable is directly coupled to an MMF cable, an effect known as Differential Mode Delay (DMD) might occur. See the *Catalyst 4500 Series Module Installation Guide* for more information.

**Figure 4-3** Installing the 10-Gigabit Ethernet X2 Module

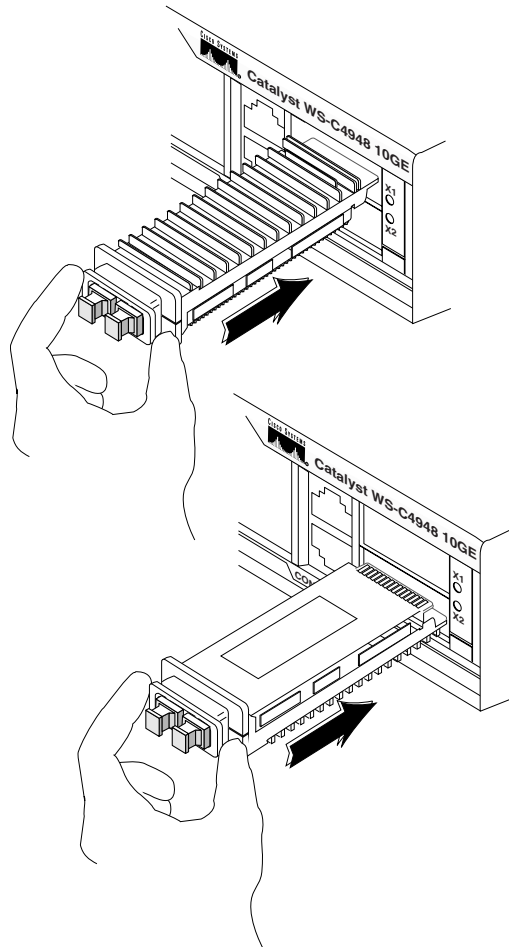

130091



**Caution**

If you attempt to insert the bottom X2 module with the cooling fins pointing up, you will probably permanently damage the connector. For either the top or bottom connector, forcing a module could potentially damage both the module and the switch.

**Tip**

For complete information on inspecting and cleaning fiber-optic connections, refer to the white-paper document at this URL:

[http://www.cisco.com/en/US/tech/tk482/tk876/technologies\\_white\\_paper09186a0080254eba.shtml](http://www.cisco.com/en/US/tech/tk482/tk876/technologies_white_paper09186a0080254eba.shtml)

## Module Maintenance Guidelines

To properly maintain modules, follow these guidelines:

- To prevent ESD damage, follow normal handling procedures.
- When the module is stored or when a fiber-optic cable is not plugged in, always keep plugs in the optical bores.
- The most common source of contaminants in the optical bores is debris picked up on the ferrules of the optical connectors. Use an alcohol swab or Kim-Wipe to clean the ferrules of the optical connector.

**Warning**

**Invisible laser radiation may be emitted from disconnected fibers or connectors. Do not stare into beams or view directly with optical instruments.**  
Statement 1051

## Cleaning the Fiber-Optic Connectors

In a fiber-optic system, light is transmitted through an extremely small fiber core, often 62.5 microns or less in diameter. Because dust particles range from a tenth of a micron to several microns in diameter, dust and any contamination at the end of the fiber core can degrade the performance of the connector interface where the two cores meet. Therefore, the connector must be precisely aligned, and the connector interface must be absolutely free of trapped foreign material.

Connector loss, or insertion loss, is a critical performance characteristic of a fiber-optic connector. Return loss is also an important factor. Return loss specifies the amount of reflected light; the lower the reflection, the better the connection. The best physical contact connectors have return losses greater than  $-40$  dB, although  $-20$  to  $-30$  dB is more common.

The connection quality depends on the type of connector and the proper cleaning and connection techniques. Dirty fiber connectors are a common source of light loss. Keep the connectors clean at all times, and keep the dust covers installed when the connectors are not in use.

Before installing any type of cable or connector, use a lint-free alcohol pad from a cleaning kit to clean the ferrule, the protective white tube around the fiber, and the end-face surface of the fiber.

As a general rule, whenever there is a significant, unexplained loss of light, clean the connectors.

**Caution**

---

Use extreme care when removing or installing connectors so that you do not damage the connector housing or scratch the end-face surface of the fiber. Always install protective covers on unused or disconnected components to prevent contamination. Always clean fiber connectors before installing them.

---

To clean the optical connectors, use a CLETOP cassette cleaner (type A for SC connectors or type B for MT-RJ connectors) and follow the product directions. If a CLETOP cassette cleaner is not available, follow these steps:

- 
- Step 1** Use a lint-free tissue soaked in 99 percent pure isopropyl alcohol to gently wipe the faceplate. Wait five seconds for the surfaces to dry, and repeat.
  - Step 2** Remove any residual dust from the faceplate with clean, dry, oil-free compressed air.

**Warning**

---

**Invisible laser radiation may be emitted from disconnected fibers or connectors. Do not stare into beams or view directly with optical instruments.**  
Statement 1051

---

- Step 3** Use a magnifying glass or inspection microscope to inspect the ferrule at an angle. Do not look directly into the aperture. Repeat the process if any contamination is detected.
- 

## Additional Guidelines

The connectors used inside the system have been cleaned by the manufacturer and connected to the adapters in the proper manner. The operation of the system should be error free if the customer provides clean connectors on the application side, follows the previous directions, and follows these guidelines:

- Clean the connectors using either a CLETOP cassette cleaner (Type A for SC connectors and Type B for MT-RJ connectors) or lens tissues before connecting to the adapters. Use pure alcohol to remove contamination.
- Do not clean the inside of the connector adapters.
- Do not use force or quick movements when connecting the fiber-optic connectors in the adapters.
- Cover the connectors and adapters to keep the inside of the adapters or the surface of the connectors from getting dirty when you are not using the connectors or while you are cleaning the chassis.







# CHAPTER 5

## Troubleshooting the Installation

---

This chapter describes how to troubleshoot the switch hardware installation and contains these sections:

- Getting Started, page 5-2
- Problem Solving to the System Component Level, page 5-2
- Identifying Startup Problems, page 5-3
- Troubleshooting the Power Supply, page 5-5
- Contacting Customer Service, page 5-6

If your system has problems starting up, use the information in this chapter to help isolate the cause. Problems with the initial startup are often caused by poor or improper connections. Although temperature conditions above the maximum acceptable level rarely occur at initial startup, environmental monitoring functions are included because they also monitor DC-line voltages.



### Note

---

For configuration questions or problems, refer to the software configuration guide or the command reference publication.

---

# Getting Started

When the initial system boot is complete, verify the following:

- Power supplies are supplying power to the system.
- The system fan assembly is operating.
- System software boots successfully.

If all of these conditions are met and the hardware installation is complete, refer to the Software Configuration Guide and the Command Reference publications to troubleshoot the software. However, if any of these conditions are not met, use the procedures in this chapter to isolate and, if possible, resolve the problem.

## Problem Solving to the System Component Level

The key to success when troubleshooting the system is to isolate the problem to a specific system component. The first step is to compare what the system *is doing* to what it *should be doing*. Because a startup problem can usually be attributed to a single component, it is more efficient to isolate the problem to a subsystem rather than troubleshoot each separate component in the system.

The switch consists of the following subsystems:

- Power supply—Includes the power supply and power supply cooling. (See the “Troubleshooting the Power Supply” section on page 5-5.)
- Fan assembly system—The chassis fan assembly should operate whenever system power is on. Usually, it continues to operate even when the environmental monitor shuts down the system because of an overtemperature or overvoltage condition. (It will shut down for a power supply shutdown.) You should be able to hear the fan assembly to determine whether or not it is operating. If the FAN LED is orange and you determine that the fan assembly is not operating, you should immediately contact a customer service representative. There are no installation adjustments that you can make if the fan assembly does not function properly at the initial startup.

# Identifying Startup Problems

When you connect the power cords to the switch, follow these steps:

- 
- Step 1** Flip the power switches to the on position (AC powered systems only).
  - Step 2** Verify that power is available to the power supplied from the site AC or DC source. Flip breakers and fuses if necessary.
  - Step 3** Listen for the system fan assembly. If you do not immediately hear the system fan assembly begin to operate, see “Troubleshooting the Power Supply” section on page 5-5.
  - Step 4** If you determine that the power supplies are functioning normally and that the fan assembly is faulty, contact a customer service representative. If the system fan assembly does not function properly at initial startup, there are no installation adjustments that you can make.
- 

## LED Readings

LEDs indicate all system states in the startup sequence. By checking the LEDs, you can determine when and where the system failed in the startup sequence. To check the LEDs, follow these steps:

- 
- Step 1** Compare the LED states to those in Table 5-1.

**Table 5-1 Power Supply LED Meanings**

LED and Color	Meaning
INPUT OK (AC)	This LED should turn green immediately when power is applied to the supply and the power switch is set to ON.
Green	AC input voltage is greater than 82 +/-3V.
Red	In a dual power supply configuration (alternate unit powered) the AC input is less than 73 +/-3V, or the power supply is turned off.
Off	AC input voltage is less than 73 +/-3V, or the power supply is turned off.
INPUT OK (DC)	This LED should turn green immediately when power is applied to the supply.
Green	DC input voltage is greater than -38.25 +/-2.25V.
Red	In a dual power supply configuration (alternate unit powered) the DC input is less than 33 +/-3V, or the power supply is turned off.
Off	In a single supply configuration, the LED shall be off to signal that DC input is less than 33 +/-3V, or the power supply is turned off.
OUTPUT OK	
Green	DC output voltages are within the normal operating range.
Red	Output voltage between the minimum and maximum limits will not create an output fail alarm. Output voltages below the minimum or above the maximum will create an output fail alarm and cause the LED to illuminate red.

**Step 2** Verify that the LEDs on the front panel are lit:

- The STATUS LED flashes yellow during diagnostic boot tests. It is green when the switch is operational (online). If the system software is unable to start up, this LED stays orange.

- The port LEDs (1-48) are green when the module is operational (online). If no signal is detected, the LINK LED is off. The port LED remains yellow if the port is disabled. The port LED flashes yellow if the port tested faulty at startup.
- Step 3** If a STATUS LED is red, contact a customer service representative for instructions.
- Step 4** If the boot information and system banner are not displayed, verify that the terminal is set correctly and that it is connected properly to the console port.
- 

## Troubleshooting the Power Supply

Follow these steps to help isolate a power subsystem problem:

- Step 1** Verify that the power supply is plugged in and that the on/off switch is set to ON (if the power supply is an AC supply).
- Step 2** Look at the power supply LED (PS1 or PS2). If the LED is off or if the LED is red, unplug the power cord, and then plug the power cord in. Be sure the on/off switch is OFF before removing the power cord from the power supply.
- Step 3** If the LED remains off, there might be a problem with the AC or DC source or the power cable.
- Step 4** Connect the power cord to another power source if one is available.
- Step 5** If the LED then lights, the problem is the first power source.
- Step 6** If the LED fails to light after you connect the power supply to a new power source, replace the power cord.
- Step 7** If the LED still fails to light when the switch is connected to a different power source with a new power cord, the power supply is probably faulty.
- If you are unable to resolve the problem, contact a customer service representative for instructions.
-

# Contacting Customer Service

If you are unable to solve a startup problem after using the troubleshooting suggestions in this chapter, contact a customer service representative for assistance and further instructions. Before you call, have the following information ready to help your service provider assist you as quickly as possible:

- Date you received the switch
- Chassis serial number (located on a label on the right of the rear of the chassis, see Figure 5-1)
- Type of software and release number
- Maintenance agreement or warranty information
- Brief description of the problem
- Brief explanation of the steps you have already taken to isolate and resolve the problem

**Figure 5-1** Serial Number Location

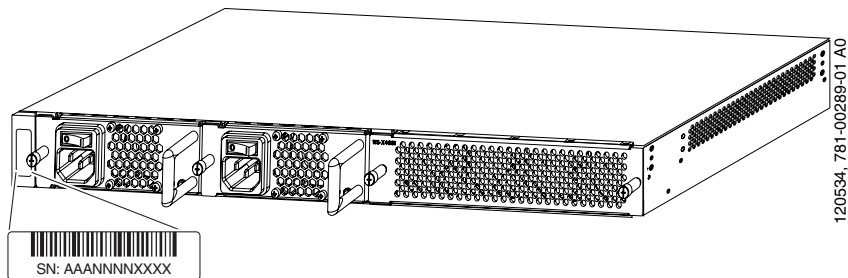



# APPENDIX **A**

## Specifications

---

This appendix provides cable and technical specifications for the Catalyst 4900 series switches.

## Console Port

The console port is an RJ-45 receptacle. The Request to Send (RTS) signal tracks the state of the Clear to Send (CTS) input. Table A-1 lists the console port pinouts.

**Table A-1**      **Console Port Pinouts**

<b>Pin</b>	<b>Signal</b>	<b>Direction</b>	<b>Description</b>
1	RTS	output	request to send
2	DTR	output	data terminal ready
3	TXD	output	transmit data
4	GND	—	—
5	GND	—	—
6	RXD	input	receive data
7	DSR	input	data set ready
8	CTS	input	clear to send

# Management Port

The 10/100BASE-T (Catalyst 4948) or 10/100/1000BASE-T (Catalyst 4948-10GE) management port use an RJ-45 receptacle with a Link Status LED. Table A-2 lists the 10/100BASE-T port pinouts.

**Table A-2**      **10/100BASE-T Port Pinouts**

Pin	Signal	Direction	Description
1	RXDP	input	receive data
2	RXDN	input	receive data
3	TXDP	output	transmit data
4	unused	—	—
5	unused	—	—
6	TXDN	output	transmit data
7	unused	—	—
8	unused	—	—

Table A-3 lists the 10/100/1000BASE-T port pinouts.

**Table A-3**      **10/100/1000 BASE-T Port Pinouts**

Pin	Signal	Description
1	TXRX0P	Bidirectional data pair 0
2	TXRX0N	Bidirectional data pair 0
3	TXRX1P	Bidirectional data pair 1
4	TXRX2P	Bidirectional data pair 2
5	TXRX2N	Bidirectional data pair 2
6	TXRX1N	Bidirectional data pair 1
7	TXRX3P	Bidirectional data pair 3
8	TXRX3N	Bidirectional data pair 3



# Catalyst 4900 Series Switch Specifications

Table A-4 shows Catalyst 4900 series switch specifications.

**Table A-4** Catalyst 4900 Series Switch Specifications

Item	Specification
<b>Environmental</b>	
Temperature, ambient operating	32°F (0°C) to 104°F (40°C)
ambient nonoperating and storage	–40 to 167°F (–40 to 75°C)
Humidity (RH), ambient (noncondensing) operating	10% to 90%
nonoperating and storage	5% to 95%
Altitude operating and nonoperating	–60 to 2000 m
Switch heat dissipation	1023 BTU/hour (Catalyst 4928-10GE) 600 BTU/hour (Catalyst 4948) 723 BTU/hour (Catalyst 4948-10GE)
System power dissipation	150 W (Catalyst 4928-10GE) 200 W (Catalyst 4948) 211 W (Catalyst 4948-10GE)
<b>Switching Components</b>	
Memory	256-MB SDRAM, 64-MB Flash, 256 bytes serial EEROM (all fixed and not upgradeable)
<b>Physical Characteristics</b>	
Dimensions (H x W x D)	1.75 x 17.5 x 16 in. (4.5 x 44.5 x 40.6 cm)
Weight	17.5 lb (7.9 kg) for a system with two power supplies, 2.0 lb (0.9 kg) per power supply
Airflow	Sides in, rear out
<b>AC Power</b>	
Minimum input	85 VAC

**Table A-4 Catalyst 4900 Series Switch Specifications (continued)**

<b>Item</b>	<b>Specification</b>
Power supply output	300 W
AC-input	4 A maximum @ 100 VAC 2 A maximum @ 240 VAC
AC frequency	50 to 60 Hz
Output current	25 A max
Peak current	4 A max @ 100 VAC 2 A max @ 240 VAC
Inrush value	20 A for one cycle of AC
Output voltage	12 V
Input KVA rating	0.375 KVA
<b>DC Power</b>	
Minimum input	-40.5 VDC
Power supply output	300 W
DC-input	8 A @ -48 to -60 VDC
Output current	25 A max
Peak current	8 A @ -48 to -60 VDC
Inrush value	Cold turn on (PSU off for > 1 hour) – 45 A Hot turn on (PSU on for > 1 hour) – 90 A
Output voltage	12 V
Input KVA rating	0.4 KVA



## APPENDIX **B**

# Initial Configuration for the Switch

---

This chapter provides a quick step-by-step initial setup procedure for a switch. These steps describe how to do a simple installation:

1. Connecting to the Switch, page B-2
2. Starting the Terminal-Emulation Software, page B-3
3. Connecting to a Power Source, page B-3
4. Entering the Initial Configuration Information, page B-4



---

**Note**

If you are using a DC power supply, see the “Connecting DC Power to the Switch” section on page 3-11 for more information about setting up your switch with a DC power supply.

---



---

**Note**

You need to provide the Category 5 straight-through cables to connect the switch ports to other Ethernet devices.

---

# Connecting to the Switch

You must use the console port to perform the initial configuration. To connect the switch console port to a PC, use the supplied RJ-45-to-DB-9 adapter cable.

Follow these steps to connect the PC or terminal to the switch:

- 
- Step 1** Using the supplied RJ-45-to-DB-9 adapter cable, insert the RJ-45 connector into the console port that is located on the front of the switch, as shown in Figure B-1.
- Step 2** Attach the DB-9 female DTE of the adapter cable to a PC serial port, or attach an appropriate adapter to the terminal.
- 

**Figure B-1** Connecting a Switch to a PC

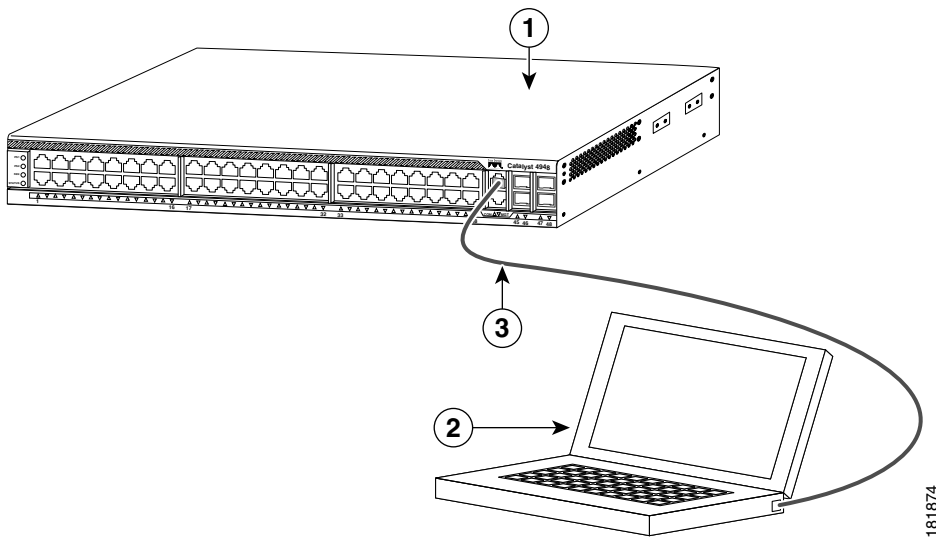

181874

1	Switch
2	Laptop
3	RJ-45-to-DB-9 adapter cable

# Starting the Terminal-Emulation Software

Before you power on the switch, start the terminal-emulation session so that you can see the output display from the power-on self-test (POST).

The terminal-emulation software—frequently a PC application such as Hyperterminal or ProcommPlus—makes communication between the switch and your PC or terminal possible.

- 
- Step 1** Start the terminal-emulation program if you are using a PC or terminal.
- Step 2** Start a terminal-emulation session.
- Step 3** Configure the baud rate and character format of the PC or terminal to match these console port default characteristics:
- 9600 baud
  - 8 data bits
  - 1 stop bit
  - No parity
  - None (flow control)
- 

# Connecting to a Power Source

Follow these steps to connect to a power source:

- 
- Step 1** If you are using an AC power supply, connect one end of the supplied AC power cord to the power connector on the switch rear panel, and then connect the other end of the power cable to a grounded AC outlet. (See Figure B-1.)
- Step 2** If you are using a DC power supply, see the “Connecting DC Power to the Switch” section on page 3-11 for instructions on how to install the DC power supply.
- 

As the switch powers on, it begins the POST, a series of tests that runs automatically to ensure that the switch functions properly.

POST lasts approximately 1 minute. After POST is complete, the system and status LEDs remain green (see the “Front Panel LEDs” section on page 1-9 for more information).

If the switch fails POST, the system LED turns amber.

**Note**

---

POST failures are usually fatal. Call Cisco Systems if your switch does not pass POST.

---

If you started the terminal-emulation program before you powered on your switch, the PC or terminal displays the bootloader sequence. Press Enter to display the setup program prompt.

## Entering the Initial Configuration Information

To set up the switch, you need to assign an IP address and other configuration information necessary for the switch to communicate with the local routers and the Internet. The minimal configuration provided here does not cover most of the features, it simply allows you to perform other configuration tasks using a telnet connection from your management network. To configure other features and interfaces, please refer to the *Catalyst 4500 Series Switch Software Configuration Guide*.

## IP Settings

Obtain this information from your network administrator:

- Switch IP address
- Subnet mask (IP netmask)
- Default gateway (router)
- Enable secret password
- Enable password
- Telnet password

## Performing the Initial Configuration

Follow these steps to complete the initial configuration for the switch:

- Step 1** At the terminal prompt, enter the enable command to enter privileged exec mode:

```
Switch> enable  
Password: password  
Switch#
```

- Step 2** Set the system time using the **clock set** command in privileged EXEC mode.

```
Switch# clock set 20:09:01 3 Apr 2006
```

- Step 3** Verify the change by entering the **show clock** command.

```
Switch# show clock  
20:09:06.079 UTC Thu Apr 3 2006
```

- Step 4** Enter the **configure terminal** command to enter global configuration mode.

```
Switch# configure terminal  
Enter configuration commands, one per line. End with CNTL/Z.  
Switch (config)#
```

- Step 5** Configure a host name for the switch, and press **Return**.

```
Switch (config)# hostname Switch1
```

- Step 6** Configure the system prompt for the switch, and press **Return**. To remove the new prompt and return the prompt to its default, use the **no prompt** command.

```
Switch (config)# prompt Switch1>
```

- Step 7** Use the **banner motd** global configuration command to set location information in the login banner. You can also set a system contact using this command.

```
Switch1(config)# banner motd c 170 West Tasman Drive, San Jose, CA c
```

or

```
Switch1 (config)# banner motd c 170 West Tasman Drive, San Jose, CA;  
Tech Support 408 123 4567 c
```

- Step 8** Configure an enable secret password, and press **Return**.

The password can be from 1 to 25 alphanumeric characters, can start with a number, is case sensitive, allows spaces, but ignores leading spaces. The secret password is encrypted and the enable password is in plain text.

```
Switch1 (config)# enable secret SecretPassword
```

- Step 9** Configure an enable password, and press **Return**.

```
Switch1 (config)# enable password EnablePassword
```

- Step 10** Configure a virtual terminal (Telnet) password, and press **Return**.

The password can be from 1 to 25 alphanumeric characters, is case sensitive, allows spaces, but ignores leading spaces.

```
Switch1 (config)# password terminal-password
Switch1 (config)# line vty 0 15
```

- Step 11** Configure the interface that connects to the management network. (The IP address and subnet mask shown are for example only. Use an address appropriate for your network.)

```
Switch1 (config)# ip routing
Switch1 (config)# interface gigabitethernet 24
Switch1 (config-if)# no switchport
Switch1 (config-if)# no shutdown
Switch1 (config-if)# ip address 10.4.120.106 255.0.0.0
Switch1 (config-if)# exit
```

- Step 12** Exit from global configuration mode:

```
Switch (config)# exit
Switch #
```

- Step 13** View the configuration you just created and confirm that it is what you want.

```
Switch1# show run
!
hostname Switch1
!
banner motd ^C
170 West Tasman Drive, San Jose, CA ^C
!

!--- Output suppressed.
```

- Step 14** Verify the IP information by using the **show ip interface brief** and **show ip route** commands.

```
Switch1# show ip interface brief
```



```

Interface          IP-Address      OK?    Method      Status
Protocol
Vlan1              172.16.1.2     YES    manual      up
up
FastEthernet1     unassigned     YES    unset       up
up

!--- Output suppressed.
Switch1# show ip route
Codes: C - connected, S - static, I - IGRP, R - RIP, M - mobile, B -
BGP
       D - EIGRP, EX - EIGRP external, O - OSPF, IA - OSPF inter area
       N1 - OSPF NSSA external type 1, N2 - OSPF NSSA external type 2
       E1 - OSPF external type 1, E2 - OSPF external type 2, E - EGP
       i - IS-IS, L1 - ISIS level-1, L2 - ISIS level-2, ia - ISIS
inter area
       * - candidate default, U - per-user static route, o - ODR
       P - periodic downloaded static route

Gateway of last resort is 172.16.1.1 to network 0.0.0.0

       172.16.0.0/24 is subnetted, 1 subnets
C       172.16.1.0 is directly connected, Vlan1
S*    0.0.0.0/0 [1/0] via 172.16.1.1
Switch1#

```

**Step 15** Save the running configuration:

```
Switch1# copy system:running-config nvram:startup-config
```

You have now completed the initial configuration of the switch.

---

To use the CLI to perform additional configuration or management tasks, enter commands at the Switch> prompt through the console port by using a terminal program or through the network by using Telnet. For configuration information, refer to the switch software configuration guide or the switch command reference.

■ Entering the Initial Configuration Information



# APPENDIX **C**

## Compliance Information and Translated Safety Warnings

---



### Note

Only trained and qualified service personnel (as defined in IEC 60950-1 and AS/NZS 60950) should install, replace, or service the equipment. Install the system in accordance with the U.S. National Electric Code if you are in the United States.

---



### Warning

### IMPORTANT SAFETY INSTRUCTIONS

**This warning symbol means danger. You are in a situation that could cause bodily injury. Before you work on any equipment, be aware of the hazards involved with electrical circuitry and be familiar with standard practices for preventing accidents. Use the statement number provided at the end of each warning to locate its translation in the translated safety warnings that accompanied this device.** Statement 1071

### SAVE THESE INSTRUCTIONS

---

This document includes the following sections:

- Translated Safety Warnings, page C-2
- Regulatory Standards Compliance, page C-39
- European Directives, page C-42

- California Perchlorate Contamination Prevention Act (Title 22, California Code of Regulations, Chapter 33), page C-46
- EMC Class A Notices and Warnings, page C-46

## Translated Safety Warnings

This section repeats in multiple languages the warnings in this guide.

### Statement 1003—DC Power Disconnection



**Warning**

**Before performing any of the following procedures, ensure that power is removed from the DC circuit.** Statement 1003

**Waarschuwing**

**Voordat u een van de onderstaande procedures uitvoert, dient u te controleren of de stroom naar het gelijkstroom circuit uitgeschakeld is.**

**Varoitus**

**Varmista, että tasavirtapiirissä ei ole virtaa ennen seuraavien toimenpiteiden suorittamista.**

**Attention**

**Avant de pratiquer l'une quelconque des procédures ci-dessous, vérifiez que le circuit en courant continu n'est plus sous tension.**

**Warnung**

**Vor Ausführung der folgenden Vorgänge ist sicherzustellen, daß die Gleichstromschaltung keinen Strom erhält.**

**Avvertenza**

**Prima di svolgere una qualsiasi delle procedure seguenti, verificare che il circuito CC non sia alimentato.**

**Advarsel**

**Før noen av disse prosedyrene utføres, kontroller at strømmen er frakoblet likestrømkretsen.**

**Aviso**

**Antes de executar um dos seguintes procedimentos, certifique-se que desligou a fonte de alimentação de energia do circuito de corrente contínua.**

**¡Advertencia!** Antes de proceder con los siguientes pasos, comprobar que la alimentación del circuito de corriente continua (CC) esté cortada (OFF).

**Varning!** Innan du utför någon av följande procedurer måste du kontrollera att strömförsörjningen till likströmskretsen är bruten.

**Aviso** Antes de executar qualquer um dos procedimentos a seguir, verifique se a energia foi removida do circuito DC.

**Advarsel** Før du udfører nogen af følgende procedurer, skal du sikre dig, at der ikke er strøm til jævnstrømskredsløbet.

**Figyelem** Mielőtt a következő eljárások bármelyikét végrehajtaná, feltétlenül szakítsa meg az egyenáramú áramkör tápellátását.

**Предупреждение** Перед выполнением любых описанных ниже действий убедитесь, что цепь питания постоянным током отключена.

**警告** 在进行下述任一操作过程之前，要确保将电源从直流电路上断开。

**警告** 次の手順を開始する前に、DC回路から電源が切断されていることを確認してください。

**주의** 다음 작업을 진행하기 전에, 직류 회로에서 전원이 차단되었는지 확인하십시오.

**تحذير** قبل القيام بأي من الإجراءات التالية، تأكد من فصل التيار من دائرة التيار المباشر.

## Statement 1004—Installation Instructions

**Warning**

**Read the installation instructions before connecting the system to the power source.** Statement 1004

**Waarschuwing**

**Raadpleeg de installatie-instructies voordat u het systeem op de voedingsbron aansluit.**

**Varoitus**

**Lue asennusohjeet ennen järjestelmän yhdistämistä virtalähteeseen.**

**Attention**

**Avant de brancher le système sur la source d'alimentation, consulter les directives d'installation.**

**Warnung**

**Vor dem Anschließen des Systems an die Stromquelle die Installationsanweisungen lesen.**

**Avvertenza**

**Consultare le istruzioni di installazione prima di collegare il sistema all'alimentatore.**

**Advarsel**

**Les installasjonsinstruksjonene før systemet kobles til strømkilden.**

**Aviso**

**Leia as instruções de instalação antes de ligar o sistema à fonte de energia.**

**¡Advertencia!**

**Lea las instrucciones de instalación antes de conectar el sistema a la red de alimentación.**

**Varning!**

**Läs installationsanvisningarna innan du kopplar systemet till strömförsörjningsenheten.**

**Figyelem**

**Mielőtt áramforráshoz csatlakoztatná a rendszert, olvassa el az üzembe helyezési útmutatót!**

**Предупреждение**

**Перед подключением устройства к источнику электропитания ознакомьтесь с данной инструкцией по установке.**

**警告** 在将系统与电源连接之前，请仔细阅读安装说明。

**警告** 必ず設置手順を読んでから、システムを電源に接続してください。

**Upozorenje** **Prije obavljanja nekog od sljedećih postupaka, provjerite da u krugovima s istosmjernom strujom nema napajanja.**

**Upozornění** **Před provedením kterékoliv z následujících operací odpojte napájení od stejnosměrného obvodu.**

**Προειδοποίηση** Πριν να ακολουθήσετε οποιαδήποτε από τις παρακάτω διαδικασίες, βεβαιωθείτε ότι έχει διακοπεί η τροφοδοσία από το κύκλωμα συνεχούς ρεύματος.

**אזהרה** לפני ביצוע אחד מהנהלים הבאים, ודא שאפסקת החשמל למעגל הזרם הישר (DC) מנותקת.

**Opomena** Пред вршење на која и да е од следните постапки, погрижете се да нема напојување на струјните кола со едновременна струја.

**Ostrzeżenie** **Przed przystąpieniem do wykonywania poniższych procedur należy upewnić się, że odłączono zasilanie od obwodu prądu stałego.**

**Upozornenie** **Pred vykonaním ktorejkoľvek z nasledujúcich operácií odpojte napájanie od jednosmerného obvodu.**

## Statement 1006—Chassis Warning for Rack-Mounting and Servicing



### Warning

To prevent bodily injury when mounting or servicing this unit in a rack, you must take special precautions to ensure that the system remains stable. The following guidelines are provided to ensure your safety:

- This unit should be mounted at the bottom of the rack if it is the only unit in the rack.
- When mounting this unit in a partially filled rack, load the rack from the bottom to the top with the heaviest component at the bottom of the rack.
- If the rack is provided with stabilizing devices, install the stabilizers before mounting or servicing the unit in the rack. Statement 1006

### Waarschuwing

Om lichamelijk letsel te voorkomen wanneer u dit toestel in een rek monteert of het daar een servicebeurt geeft, moet u speciale voorzorgsmaatregelen nemen om ervoor te zorgen dat het toestel stabiel blijft. De onderstaande richtlijnen worden verstrekt om uw veiligheid te verzekeren:

- Dit toestel dient onderaan in het rek gemonteerd te worden als het toestel het enige in het rek is.
- Wanneer u dit toestel in een gedeeltelijk gevuld rek monteert, dient u het rek van onderen naar boven te laden met het zwaarste onderdeel onderaan in het rek.
- Als het rek voorzien is van stabiliseringshulpmiddelen, dient u de stabilisatoren te monteren voordat u het toestel in het rek monteert of het daar een servicebeurt geeft.

### Varoitus

Kun laite asetetaan telineeseen tai huolletaan sen ollessa telineessä, on noudatettava erityisiä varotoimia järjestelmän vakavuuden säilyttämiseksi, jotta vältytään loukkaantumiselta. Noudata seuraavia turvallisuusohjeita:

- Jos telineessä ei ole muita laitteita, aseta laite telineen alaosaan.
- Jos laite asetetaan osaksi täytettyyn telineeseen, aloita kuormittaminen sen alaosaan kaikkein raskaimmalla esineellä ja siirry sitten sen yläosaan.
- Jos telinettä varten on vakaimet, asenna ne ennen laitteen asettamista telineeseen tai sen huoltamista siinä.



- Attention** Pour éviter toute blessure corporelle pendant les opérations de montage ou de réparation de cette unité en casier, il convient de prendre des précautions spéciales afin de maintenir la stabilité du système. Les directives ci-dessous sont destinées à assurer la protection du personnel:
- Si cette unité constitue la seule unité montée en casier, elle doit être placée dans le bas.
  - Si cette unité est montée dans un casier partiellement rempli, charger le casier de bas en haut en plaçant l'élément le plus lourd dans le bas.
  - Si le casier est équipé de dispositifs stabilisateurs, installer les stabilisateurs avant de monter ou de réparer l'unité en casier.
- Warnung** Zur Vermeidung von Körperverletzung beim Anbringen oder Warten dieser Einheit in einem Gestell müssen Sie besondere Vorkehrungen treffen, um sicherzustellen, daß das System stabil bleibt. Die folgenden Richtlinien sollen zur Gewährleistung Ihrer Sicherheit dienen:
- Wenn diese Einheit die einzige im Gestell ist, sollte sie unten im Gestell angebracht werden.
  - Bei Anbringung dieser Einheit in einem zum Teil gefüllten Gestell ist das Gestell von unten nach oben zu laden, wobei das schwerste Bauteil unten im Gestell anzubringen ist.
  - Wird das Gestell mit Stabilisierungszubehör geliefert, sind zuerst die Stabilisatoren zu installieren, bevor Sie die Einheit im Gestell anbringen oder sie warten.
- Avvertenza** Per evitare infortuni fisici durante il montaggio o la manutenzione di questa unità in un supporto, occorre osservare speciali precauzioni per garantire che il sistema rimanga stabile. Le seguenti direttive vengono fornite per garantire la sicurezza personale:
- Questa unità deve venire montata sul fondo del supporto, se si tratta dell'unica unità da montare nel supporto.
  - Quando questa unità viene montata in un supporto parzialmente pieno, caricare il supporto dal basso all'alto, con il componente più pesante sistemato sul fondo del supporto.
  - Se il supporto è dotato di dispositivi stabilizzanti, installare tali dispositivi prima di montare o di procedere alla manutenzione dell'unità nel supporto.

- Advarsel**      **Unngå fysiske skader under montering eller reparasjonsarbeid på denne enheten når den befinner seg i et kabinett. Vær nøye med at systemet er stabilt. Følgende retningslinjer er gitt for å verne om sikkerheten:**
- Denne enheten bør monteres nederst i kabinettet hvis dette er den eneste enheten i kabinettet.
  - Ved montering av denne enheten i et kabinett som er delvis fylt, skal kabinettet lastes fra bunnen og opp med den tyngste komponenten nederst i kabinettet.
  - Hvis kabinettet er utstyrt med stabiliseringsutstyr, skal stabilisatorene installeres før montering eller utføring av reparasjonsarbeid på enheten i kabinettet.
- Aviso**      **Para se prevenir contra danos corporais ao montar ou reparar esta unidade numa estante, deverá tomar precauções especiais para se certificar de que o sistema possui um suporte estável. As seguintes directrizes ajudá-lo-ão a efectuar o seu trabalho com segurança:**
- Esta unidade deverá ser montada na parte inferior da estante, caso seja esta a única unidade a ser montada.
  - Ao montar esta unidade numa estante parcialmente ocupada, coloque os itens mais pesados na parte inferior da estante, arrumando-os de baixo para cima.
  - Se a estante possuir um dispositivo de estabilização, instale-o antes de montar ou reparar a unidade.
- ¡Advertencia!**      **Para evitar lesiones durante el montaje de este equipo sobre un bastidor, o posteriormente durante su mantenimiento, se debe poner mucho cuidado en que el sistema quede bien estable. Para garantizar su seguridad, proceda según las siguientes instrucciones:**
- Colocar el equipo en la parte inferior del bastidor, cuando sea la única unidad en el mismo.
  - Cuando este equipo se vaya a instalar en un bastidor parcialmente ocupado, comenzar la instalación desde la parte inferior hacia la superior colocando el equipo más pesado en la parte inferior.
  - Si el bastidor dispone de dispositivos estabilizadores, instalar éstos antes de montar o proceder al mantenimiento del equipo instalado en el bastidor.

- Varning!** För att undvika kroppsskada när du installerar eller utför underhållsarbete på denna enhet på en ställning måste du vidta särskilda försiktighetsåtgärder för att försäkra dig om att systemet står stadigt. Följande riktlinjer ges för att trygga din säkerhet:
- Om denna enhet är den enda enheten på ställningen skall den installeras längst ned på ställningen.
  - Om denna enhet installeras på en delvis fylld ställning skall ställningen fyllas nedifrån och upp, med de tyngsta enheterna längst ned på ställningen.
  - Om ställningen är försedd med stabiliseringsdon skall dessa monteras fast innan enheten installeras eller underhålls på ställningen.
- Aviso** Para evitar lesões corporais ao montar ou dar manutenção a esta unidade em um rack, é necessário tomar todas as precauções para garantir a estabilidade do sistema. As seguintes orientações são fornecidas para garantir a sua segurança:
- Se esta for a única unidade, ela deverá ser montada na parte inferior do rack.
  - Ao montar esta unidade em um rack parcialmente preenchido, carregue-o de baixo para cima com o componente mais pesado em sua parte inferior.
  - Se o rack contiver dispositivos estabilizadores, instale-os antes de montar ou dar manutenção à unidade existente.
- Advarsel** For at forhindre legemesbeskadigelse ved montering eller service af denne enhed i et rack, skal du sikre at systemet står stabilt. Følgende retningslinjer er også for din sikkerheds skyld:
- Enheden skal monteres i bunden af dit rack, hvis det er den eneste enhed i racket.
  - Ved montering af denne enhed i et delvist fyldt rack, skal enhederne installeres fra bunden og opad med den tungeste enhed nederst.
  - Hvis racket leveres med stabiliseringsenheder, skal disse installeres for enheden monteres eller serviceres i racket.

**Figyelem** **A készülék rackbe történő beszerelése és karbantartása során bekövetkező sérülések elkerülése végett speciális óvintézkedésekkel meg kell őrizni a rendszer stabilitását. A személyes biztonsága érdekében tartsa be a következő szabályokat:**

- **Ha a rackben csak ez az egy készülék található, a rack aljába kell beszerelni.**
- **Ha nincs teljesen tele az a rack, amelybe beszerelik a készüléket, alulról fölfelé haladva töltsse fel a racket úgy, hogy a legnehezebb készülék kerüljön a rack aljába.**
- **Ha stabilizáló eszközök is tartoznak a rackhez, szerelje fel a stabilizátorokat, mielőtt beszerelné az egységet a rackbe, vagy karbantartást végezne rajta.**

**Предупреждение** Во избежание травм при монтаже и обслуживании устройства в стойке следует принять особые меры предосторожности, чтобы убедиться в устойчивости оборудования. Для обеспечения безопасности работ необходимо соблюдать следующие правила.

- Если в стойке находится одно устройство, оно должно быть установлено в нижней части.
- При монтаже устройств в частично заполненную стойку устанавливайте оборудование снизу вверх, размещая наиболее тяжелые устройства в нижней части.
- Если стойка снабжена приспособлениями для стабилизации, их необходимо установить до начала монтажа или обслуживания оборудования.

**警告** 为避免在机架中安装或维修该部件时使身体受伤，您必须采取特殊的预防措施确保系统固定。以下是确保安全的原则：

- 如果此部件是机架中唯一的部件，应将其安装在机架的底部。
- 如果在部分装满的机架中安装此部件，请按从下往上的顺序安装各个部件，并且最重的组件应安装在机架的底部。
- 如果机架配有固定装置，请先装好固定装置，然后再在机架中安装或维修部件。

**警告** この装置をラックに設置したり保守作業を行ったりするときは、人身事故を防ぐため、システムが安定しているかどうかを十分に確認する必要があります。次の注意事項に従ってください。

- ラックにこの装置を単独で設置する場合は、ラックの一番下に設置します。
- ラックに別の装置がすでに設置されている場合は、最も重量のある装置を一番下にして、重い順に下から上へ設置します。
- ラックに安定器具が付属している場合は、その安定器具を取り付けてから、装置をラックに設置するか、またはラック内の装置の保守作業を行ってください。



이 장치를 랙에 장착하거나 서비스할 때 신체 부상을 방지하려면, 시스템이 안정된 상태를 유지하도록 특별히 주의해야 합니다. 사용자의 안전을 위해 다음 지침 사항을 준수하십시오.

- 이 장치가 랙에 장착되는 유일한 것일 경우, 랙의 맨 아래 부분에 장착되어야 합니다.
- 부분적으로 차 있는 랙에 이 장치를 장착할 경우, 가장 무거운 장치를 랙의 맨 아래 부분부터 차례로 장착하십시오.
- 안정기가 랙과 함께 제공되는 경우, 이 안정기를 설치한 후 이 장치를 랙에 장착하거나 서비스하십시오

### تحذير

لتجنب حدوث أي إصابات عند تركيب هذه الوحدة، يجب اتباع بعض الاحتياطات لضمان عمل النظام بشكل سليم. يتم ذكر الإرشادات التالية لضمان الأمان.

يجب تركيب هذه الوحدة في الجزء السفلي من الدولاب المتضمن قضبان إذا كانت هذه الوحدة هي الوحدة الوحيدة في الدولاب الذي يحتوي على قضبان.

عند تركيب هذه الوحدة في دولاب شبه ممتلئ، قم برفع الدولاب من الجزء السفلي لأعلى بحيث يكون الجزء الأثقل وزناً أسفل الدولاب.

إذا كان الدولاب المتضمن قضباناً يحتوي على أجهزة حفظ التوازن، قم بتثبيت هذه الأجهزة قبل تركيب الوحدة في الدولاب.

- Upozorenje** Kako ne bi došlo do tjelesnih ozljeda kod postavljanja ili servisiranja uređaja na polici, potrebno je poduzeti mjere predostrožnosti kako bi sustav uvijek bio stabilan. Sigurnost se može osigurati poštivanjem sljedećih smjernica:
- Ovaj uređaj treba ugraditi na dno police, ukoliko je to jedini uređaj na polici.
  - Kod ugradnje uređaja u policu na kojoj se već nalaze drugi uređaji, policu treba opremiti počevši od dna, te tako da se na dno stave najteži dijelovi.
  - Ukoliko su na polici ugrađeni stabilizatori, njih montirajte prije ugradnje ili servisiranja uređaja na polici.
- Upozornění** Abyste předešli poranění osob při montáži nebo opravě zařízení v montážním rámu, musíte dodržovat zvláštní preventivní opatření pro zajištění udržení stability systému. Pro zajištění bezpečnosti obsluhy jsou určeny následující zásady:
- Pokud je toto zařízení jedinou jednotkou v montážním rámu, musí být namontováno na nejnižší místo rámu.
  - Pokud je toto zařízení montováno do částečně obsazeného montážního rámu, obsazujte montážní rám ve směru zdola nahoru tak, aby byla nejtěžší součást nejnižší.
  - Pokud je montážní rám vybaven stabilizačními zařízeními, nainstalujte stabilizátory ještě před montáží nebo opravou zařízení v montážním rámu.
- Προειδοποίηση** Για να αποφύγετε τον τραυματισμό κατά την τοποθέτηση ή τη συντήρηση αυτής της συσκευής σε αρθρωτό σύστημα, πρέπει να λάβετε ειδικές προφυλάξεις για να διασφαλίσετε τη σταθερότητα του συστήματος. Οι παρακάτω οδηγίες παρέχονται για να εξασφαλίσουν την ασφάλειά σας:
- Αυτή η συσκευή πρέπει να τοποθετείται στο κάτω μέρος του αρθρωτού συστήματος αν είναι η μοναδική συσκευή σε αυτό.
  - Όταν τοποθετείτε αυτήν τη συσκευή σε εν μέρει γεμάτο αρθρωτό σύστημα, τοποθετήστε συσκευές στο αρθρωτό σύστημα από κάτω προς τα επάνω, με τη βαρύτερη συσκευή στο κάτω μέρος του συστήματος.
  - Εάν το αρθρωτό σύστημα διαθέτει διατάξεις σταθεροποίησης, τοποθετήστε τους σταθεροποιητές πριν τοποθετήσετε ή συντηρήσετε τη συσκευή στο αρθρωτό σύστημα.

אזהרה כדי למנוע פציעה בעת הרכבת יחידה זו במעמד או טיפול בה, עליך לנקוט אמצעי זהירות מיוחדים כדי להבטיח את יציבות המערכת. הקווים המנחים הבאים ניתנים על מנת להבטיח את ביטחונך:

- אם יחידה זו היא יחידה בודדת במעמד, יש להרכיב את היחידה בחלקו התחתון של המעמד.
- בעת הרכבת יחידה זו במעמד המלא בחלקו, טען את המעמד החל בחלק התחתון וכלפי מעלה כאשר הרכיב הכבד ביותר נמצא בחלקו התחתון של המעמד.
- אם המעמד מסופק עם התקני ייצוב, התקן את המייצבים לפני הרכבה היחידה במעמד או טיפול בה.

Opomena За да се не повредите кога го монтирате или го сервисирате уредот на полица, мора да бидете особено претпазливи за да ја обезбедите стабилноста на системот. Следите напатствија се дадени за да ја осигураат Вашата безбедност:

- Уредот треба да се монтира најдолу на полицата ако е единствен уред на полицата.
- Кога го монтирате уредот на делумно пополнета полица, полнете ја полицата од дното кон врвот со најтешката компонента на дното на полицата.
- Ако полицата има стабилизаторски делови, наместете ги стабилизаторите пред да го монтирате или сервисирате уредот на полицата.

- Ostrzeżenie** Aby zapobiec urazom podczas montażu lub serwisowania tego urządzenia w stojaku, należy zastosować szczególne środki ostrożności w celu zapewnienia stabilności układu. Poniżej przedstawiono wskazówki, których przestrzeganie zapewni bezpieczeństwo:
- Jeśli urządzenie to jest jedynym urządzeniem w stojaku, powinno być zamontowane na dole.
  - W przypadku montażu urządzenia w częściowo zapełnionym stojaku należy instalować kolejne urządzenia od najniższego do najwyższego, przy czym element najcięższy powinien być zamontowany najniżej w stojaku.
  - Jeśli stojak jest wyposażony w elementy stabilizujące, należy zamontować stabilizatory przed przystąpieniem do montażu lub serwisowania urządzeń w stojaku.
- Upozornenie** Aby ste predišli poraneniu osôb pri montáži alebo oprave zariadenia v montážnom ráme, musíte dodržiavať zvláštne preventívne opatrenia na zaistenie udržania stability systému. Na zaistenie bezpečnosti obsluhy sú určené nasledujúce zásady:
- Pokiaľ je toto zariadenie jedinou jednotkou v montážnom ráme, musí byť namontované na najnižšie miesto v ráme.
  - Pokiaľ je toto zariadenie montované do čiastočne obsadeného montážneho rámu, obsadzujte montážny rám v smere zdola nahor tak, aby bola najťažšia súčasť najnižšie.
  - Pokiaľ je montážny rám vybavený stabilizačnými zariadeniami, nainštalujte stabilizátory ešte pred montážou alebo opravou zariadenia v montážnom ráme.

## Statement 1008—Class 1 Laser Product



**Warning**

**Class 1 laser product.** Statement 1008

**Waarschuwing**

**Klasse-1 laser produkt.**



<b>Varoitus</b>	<b>Luokan 1 lasertuote.</b>
<b>Attention</b>	<b>Produit laser de classe 1.</b>
<b>Warnung</b>	<b>Laserprodukt der Klasse 1.</b>
<b>Avvertenza</b>	<b>Prodotto laser di Classe 1.</b>
<b>Advarsel</b>	<b>Laserprodukt av klasse 1.</b>
<b>Aviso</b>	<b>Produto laser de classe 1.</b>
<b>¡Advertencia!</b>	<b>Producto láser Clase I.</b>
<b>Varning!</b>	<b>Laserprodukt av klass 1.</b>
<b>Aviso</b>	<b>Produto a laser de classe 1.</b>
<b>Advarsel</b>	<b>Klasse 1 laserprodukt.</b>
<b>Figyelem</b>	<b>Class 1 besorolású lézeres termék.</b>
<b>Предупреждение</b>	<b>Лазерное устройство класса 1.</b>
<b>警告</b>	<b>这是 1 类激光产品。</b>
<b>警告</b>	<b>クラス1レーザー製品です。</b>
<b>주의</b>	<b>클래스 1 레이저 제품.</b>
<b>تحذير</b>	<b>Class 1 Laser \ منتج</b>
<b>Upozorenje</b>	<b>Laserski proizvod klase 1</b>

## Translated Safety Warnings

Upozornění	Laserový výrobek třídy 1.
Προειδοποίηση	Προϊόν λέιζερ κατηγορίας 1.
אזהרה	מוצר לייזר Class 1.
Opomena	Ласерски производ од класа 1.
Ostrzeżenie	Produkt laserowy klasy 1.
Upozornenie	Laserový výrobok triedy 1.

---

## Statement 1011—Staring into Laser Beam



**Warning** Do not stare into the beam or view it directly with optical instruments.  
Statement 1011

**Waarschuwing** Niet in de straal staren of hem rechtstreeks bekijken met optische instrumenten.

**Varoitus** Älä katso säteeseen äläkä tarkastele sitä suoraan optisen laitteen avulla.

**Attention** Ne pas fixer le faisceau des yeux, ni l'observer directement à l'aide d'instruments optiques.

**Warnung** Nicht direkt in den Strahl blicken und ihn nicht direkt mit optischen Geräten prüfen.

**Avvertenza**      **Non fissare il raggio con gli occhi né usare strumenti ottici per osservarlo direttamente.**

**Advarsel**      **Stirr eller se ikke direkte på strålen med optiske instrumenter.**

**Aviso**      **Não olhe fixamente para o raio, nem olhe para ele directamente com instrumentos ópticos.**

**¡Advertencia!**      **No mirar fijamente el haz ni observarlo directamente con instrumentos ópticos.**

**Varning!**      **Rikta inte blicken in mot strålen och titta inte direkt på den genom optiska instrument.**

**Figyelem**      **Ne nézzen bele a sugárba, és ne nézze közvetlenül optikai berendezések segítségével!**

**Предупреждение**      **Не допускайте попадания лазерного луча в глаза и не смотрите на него через оптические приборы.**

**警告**      **请勿直视光束或直接用光学仪器观看光束。**

**警告**      **光線をのぞきこんだり、光学機器を使用して光線を直接見たりしないでください。**

## Statement 1017—Restricted Area



### Warning

**This unit is intended for installation in restricted access areas. A restricted access area can be accessed only through the use of a special tool, lock and key, or other means of security.** Statement 1017

### Waarschuwing

**Deze eenheid is bestemd voor installatie in plaatsen met beperkte toegang. Toegang tot een dergelijke plaats kan alleen verkregen worden door middel van een speciaal instrument, een slot en sleutel of een ander veiligheidsmiddel.**

### Varoitus

**Tämä laite on tarkoitettu asennettavaksi paikkaan, johon pääsy on rajoitettua. Tällaiseen paikkaan pääsee vain erikoistyökäluä, lukkoon sopivaa avainta tai jotakin muuta turvalaitetta käyttämällä.**

### Attention

**Cet appareil est à installer dans des zones d'accès réservé. L'accès à une zone d'accès réservé n'est possible qu'en utilisant un outil spécial, un mécanisme de verrouillage et une clé, ou tout autre moyen de sécurité.**

### Warnung

**Diese Einheit ist zur Installation in Bereichen mit beschränktem Zutritt vorgesehen. Der Zutritt zu derartigen Bereichen ist nur mit einem Spezialwerkzeug, Schloss und Schlüssel oder einer sonstigen Sicherheitsvorkehrung möglich.**

### Avvertenza

**Questa unità è prevista per essere installata in un'area ad accesso limitato, vale a dire un'area accessibile solo mediante l'uso di un attrezzo speciale, come lucchetto e chiave, o altri dispositivi di sicurezza.**

### Advarsel

**Denne enheten er beregnet på installasjon i områder med begrenset tilgang. Et begrenset tilgangsområde kan bare nås ved hjelp av et spesielt verktøy, lås og nøkkel, eller andre sikkerhetsanordninger.**

### Aviso

**Esta unidade foi concebida para instalação em áreas de acesso restrito. Uma área de acesso restrito é uma área à qual apenas tem acesso o pessoal de serviço autorizado, que possua uma ferramenta, chave e fechadura especial, ou qualquer outra forma de segurança.**

<b>¡Advertencia!</b>	<b>Esta unidad ha sido diseñada para instalación en áreas de acceso restringido. Sólo puede obtenerse acceso a una de estas áreas mediante la utilización de una herramienta especial, cerradura con llave u otro medio de seguridad.</b>
<b>Varning!</b>	<b>Denna enhet är avsedd för installation i områden med begränsat tillträde. Ett område med begränsat tillträde kan endast tillträdas med hjälp av specialverktyg, lås och nyckel eller annan säkerhetsanordning.</b>
<b>Aviso</b>	<b>Esta unidade deve ser instalada em áreas de acesso restrito. Uma área de acesso restrito só pode ser acessada com o uso de uma ferramenta especial, cadeado e chave ou outros meios de segurança.</b>
<b>Advarsel</b>	<b>Denne enhed er beregnet til installation i områder med begrænset adgang. Der kan kun opnås adgang til et begrænset område ved at bruge et særligt stykke værktøj, lås og nøgle, eller en anden form for sikkerhed.</b>
<b>Figyelem</b>	<b>A készülék korlátozottan hozzáférhető területre történő beszerelésre készült. A korlátozottan hozzáférhető területekhez csak speciális szerszám, zár és kulcs vagy más biztonsági berendezés segítségével lehet hozzáférni.</b>
<b>Предупреждение</b>	Данное устройство предназначено для установки в помещениях с ограниченным доступом. В такие помещения можно попасть, только имея специальное устройство доступа, карту или ключ или пройдя проверку другими средствами обеспечения безопасности.
<b>警告</b>	此部件应安装在限制进出的场所。限制进出的场所指只能通过使用特殊工具、锁和钥匙或其它安全手段进出的场所。
<b>警告</b>	この装置は立ち入り制限区域内に設置することが前提になっています。立ち入り制限区域とは、鍵、錠、またはその他の保全手段を使用しないと立ち入ることができない区域です。
<b>주의</b>	이 장치는 접근이 제한된 영역에 설치하도록 제작되었습니다. 특수 도구, 잠금 장치 및 키, 또는 기타 보안 수단을 통해서만 이 접근 제한 영역에 액세스할 수 있습니다.

تحذير تم تخصيص هذه الوحدة ليتم تثبيتها في مناطق محظور الوصول إليها. يمكن الوصول إلى المنطقة المحظورة فقط من خلال استخدام أداة خاصة أو قفل أو مفتاح أو أي وسيلة أخرى من التأمين.

**Upozorenje** Uređaj je namijenjen ugradnji na teško dostupnim mjestima. Teško su dostupna mjesta takva mjesta koja su dostupna samo uz pomoć posebnih alata, lokota i ključa, ili nekog drugog načina osiguravanja sigurnosti.

**Upozornění** Toto zařízení je určeno pro instalaci v prostorech s omezeným přístupem. Do prostoru s omezeným přístupem lze získat přístup pouze pomocí zvláštního nástroje, zámku a klíče nebo jiných zabezpečovacích prostředků.

Προειδοποίηση Αυτή η συσκευή προορίζεται για να τοποθετηθεί σε χώρους στους οποίους η πρόσβαση είναι περιορισμένη. Η πρόσβαση σε ένα χώρο με περιορισμένη πρόσβαση είναι δυνατή μόνο με τη χρήση ενός ειδικού εργαλείου, κλειδαριάς και κλειδιού ή άλλου μέσου ασφαλείας.

אזהרה יחידה זו מיועד להתקנה באזורים עם גישה מוגבלת. הגישה לאזורים המיועדים לגישה מוגבלת אפשרית רק באמצעות כלי מיוחד, מנעול ומפתח, או אמצעי בטיחות אחרים.

**Opomena** Уредот е наменет за местeње во области со ограничен пристап. Во областите со ограничен пристап може да се влезе само со употреба на специјална алатка, брава и клуч или со други средства за обезбедување.

- Ostrzeżenie** To urządzenie jest przystosowane do instalacji w miejscach o ograniczonym dostępie. Przez miejsce o ograniczonym dostępie rozumie się miejsce, do którego dostęp uzyskać można wyłącznie za pomocą specjalnego narzędzia, zamka z kluczem lub innego zabezpieczenia.
- Upozornenie** Toto zariadenie je určené na inštaláciu v priestoroch s obmedzeným prístupom. Do priestoru s obmedzeným prístupom je možné získať prístup iba pomocou špeciálneho nástroja, zámku a kľúča, alebo iných zabezpečovacích prostriedkov.

## Statement 1019—Main Disconnecting Device



### Warning

The plug-socket combination must be accessible at all times, because it serves as the main disconnecting device. Statement 1019

### Waarschuwing

De combinatie van de stekker en het elektrisch contactpunt moet te allen tijde toegankelijk zijn omdat deze het hoofdmecanisme vormt voor verbreking van de aansluiting.

### Varoitus

Pistoke/liitinkohta toimii pääkatkaisumekanismina. Pääsy siihen on pidettävä aina esteettömänä.

### Attention

La combinaison de prise de courant doit être accessible à tout moment parce qu'elle fait office de système principal de déconnexion.

### Warnung

Der Netzkabelanschluß am Gerät muß jederzeit zugänglich sein, weil er als primäre Ausschaltvorrichtung dient.

### Avvertenza

Il gruppo spina-presa deve essere sempre accessibile, poiché viene utilizzato come dispositivo di scollegamento principale.

**Advarsel** **Kombinasjonen støpsel/uttak må alltid være tilgjengelig ettersom den fungerer som hovedfrakoplingsenhet.**

**Aviso** **A combinação ficha-tomada deverá ser sempre acessível, porque funciona como interruptor principal.**

**¡Advertencia!** **El conjunto de clavija y toma ha de encontrarse siempre accesible ya que hace las veces de dispositivo de desconexión principal.**

**Varning!** **Man måste alltid kunna komma åt stickproppen i uttaget, eftersom denna koppling utgör den huvudsakliga fråkopplingsanordningen.**

**Figyelem** **A dugaszolóaljzat és a dugasz együttesének mindig hozzáférhetőnek kell lennie, mivel ez szolgál főmegszakítóként.**

**Предупреждение** Штепсельная розетка всегда должна быть доступна, поскольку она служит основным устройством отключения.

**警告** 插销和插座必须便于随时插拔，因为它是主要断电设备。

**警告** 主要な切断装置となるので、プラグとソケットは常に手が届く場所に置く必要があります。



## Statement 1024—Ground Conductor



### Warning

**This equipment must be grounded. Never defeat the ground conductor or operate the equipment in the absence of a suitably installed ground conductor. Contact the appropriate electrical inspection authority or an electrician if you are uncertain that suitable grounding is available.** Statement 1024

### Waarschuwing

**Deze apparatuur dient geaard te zijn. De aardingsleiding mag nooit buiten werking worden gesteld en de apparatuur mag nooit bediend worden zonder dat er een op de juiste wijze geïnstalleerde aardingsleiding aanwezig is. Neem contact op met de bevoegde instantie voor elektrische inspecties of met een elektricien als u er niet zeker van bent dat er voor passende aarding gezorgd is.**

### Varoitus

**Laitteiden on oltava maadoitettuja. Älä koskaan ohita maajohdinta tai käytä laitteita ilman oikein asennettua maajohdinta. Ota yhteys sähkötarkastusviranomaiseen tai sähköasentajaan, jos olet epävarma maadoituksen sopivuudesta.**

### Attention

**Cet équipement doit être mis à la masse. Ne jamais rendre inopérant le conducteur de masse ni utiliser l'équipement sans un conducteur de masse adéquatement installé. En cas de doute sur la mise à la masse appropriée disponible, s'adresser à l'organisme responsable de la sécurité électrique ou à un électricien.**

### Warnung

**Dieses Gerät muss geerdet sein. Auf keinen Fall den Erdungsleiter unwirksam machen oder das Gerät ohne einen sachgerecht installierten Erdungsleiter verwenden. Wenn Sie sich nicht sicher sind, ob eine sachgerechte Erdung vorhanden ist, wenden Sie sich an die zuständige Inspektionsbehörde oder einen Elektriker.**

### Avvertenza

**Questa apparecchiatura deve essere dotata di messa a terra. Non escludere mai il conduttore di protezione né usare l'apparecchiatura in assenza di un conduttore di protezione installato in modo corretto. Se non si è certi della disponibilità di un adeguato collegamento di messa a terra, richiedere un controllo elettrico presso le autorità competenti o rivolgersi a un elettricista.**

**Advarsel** Dette utstyret må jordes. Omgå aldri jordingslederen og bruk aldri utstyret uten riktig montert jordingsleder. Ta kontakt med fagfolk innen elektrisk inspeksjon eller med en elektriker hvis du er usikker på om det finnes velegnet jordning.

**Aviso** Este equipamento deve ser aterrado. Nunca anule o fio terra nem opere o equipamento sem um aterramento adequadamente instalado. Em caso de dúvida com relação ao sistema de aterramento disponível, entre em contato com os serviços locais de inspeção elétrica ou um eletricista qualificado.

**¡Advertencia!** Este equipo debe estar conectado a tierra. No inhabilite el conductor de tierra ni haga funcionar el equipo si no hay un conductor de tierra instalado correctamente. Póngase en contacto con la autoridad correspondiente de inspección eléctrica o con un electricista si no está seguro de que haya una conexión a tierra adecuada.

**Varning!** Denna utrustning måste jordas. Koppla aldrig från jordledningen och använd aldrig utrustningen utan en på lämpligt sätt installerad jordledning. Om det föreligger osäkerhet huruvida lämplig jordning finns skall elektrisk besiktningsauktoritet eller elektriker kontaktas.

**Figyelem** A berendezés csak megfelelő védőföldeléssel működtethető. Ne iktassa ki a földelés csatlakozóját, és ne üzemeltesse a berendezést szabályosan felszerelt földelő vezeték nélkül! Ha nem biztos benne, hogy megfelelő földelés áll rendelkezésbe, forduljon a helyi elektromos hatóságokhoz vagy egy villanyszerelőhöz.

**Предупреждение** Данное устройство должно быть заземлено. Никогда не отключайте провод заземления и не пользуйтесь оборудованием при отсутствии правильно подключенного провода заземления. За сведениями об имеющихся возможностях заземления обратитесь к соответствующим контролирующим организациям по энергоснабжению или к инженеру-электрику.

**警告** 此设备必须接地。切勿使接地导体失效，或者在没有正确安装接地导体的情况下操作该设备。如果您不能肯定接地导体是否正常发挥作用，请咨询有关电路检测方面的权威人士或电工。

**警告** この装置はアース接続する必要があります。アース導体を破損しないよう注意し、アース導体を正しく取り付けないまま装置を稼働させないでください。アース接続が適正であるかどうか分からない場合には、電気検査機関または電気技術者に相談してください。

## Statement 1030—Equipment Installation



### Warning

**Only trained and qualified personnel should be allowed to install, replace, or service this equipment.** Statement 1030

### Waarschuwing

**Deze apparatuur mag alleen worden geïnstalleerd, vervangen of hersteld door bevoegd geschoold personeel.**

### Varoitus

**Tämän laitteen saa asentaa, vaihtaa tai huoltaa ainoastaan koulutettu ja laitteen tunteva henkilökunta.**

### Attention

**Il est vivement recommandé de confier l'installation, le remplacement et la maintenance de ces équipements à des personnels qualifiés et expérimentés.**

### Warnung

**Das Installieren, Ersetzen oder Bedienen dieser Ausrüstung sollte nur geschultem, qualifiziertem Personal gestattet werden.**

### Avvertenza

**Questo apparato può essere installato, sostituito o mantenuto unicamente da un personale competente.**

### Advarsel

**Bare opplært og kvalifisert personell skal foreta installasjoner, utskiftninger eller service på dette utstyret.**

<b>Aviso</b>	<b>Apenas pessoal treinado e qualificado deve ser autorizado a instalar, substituir ou fazer a revisão deste equipamento.</b>
<b>¡Advertencia!</b>	<b>Solamente el personal calificado debe instalar, reemplazar o utilizar este equipo.</b>
<b>Varning!</b>	<b>Endast utbildad och kvalificerad personal bör få tillåtelse att installera, byta ut eller reparera denna utrustning.</b>
<b>Aviso</b>	<b>Somente uma equipe treinada e qualificada tem permissão para instalar, substituir ou dar manutenção a este equipamento.</b>
<b>Advarsel</b>	<b>Kun uddannede personer må installere, udskifte komponenter i eller servicere dette udstyr.</b>
<b>Figyelem</b>	<b>A berendezést csak szakképzett személyek helyezhetik üzembe, cserélhetik és tarthatják karban.</b>
<b>Предупреждение</b>	Установку, замену и обслуживание этого оборудования может осуществлять только специально обученный квалифицированный персонал.
<b>警告</b>	只有经过培训且具有资格的人员才能进行此设备的安装、更换和维修。
<b>警告</b>	この装置の設置、交換、保守は、訓練を受けた相応の資格のある人が行ってください。
<b>주의</b>	교육을 받고 자격을 갖춘 사람만 이 장비를 설치, 교체, 또는 서비스를 수행해야 합니다.
<b>تحذير</b>	يسمح للمُتخصِّمين فقط بتركيب المعدة أو استبدالها أو إجراء الصيانة عليها.
<b>Upozorenje</b>	<b>Uređaj smije ugrađivati, mijenjati i servisirati samo za to obučeno i osposobljeno servisno osoblje.</b>

Upozornění	Instalaci, výměnu nebo opravu tohoto zařízení smějí provádět pouze proškolené a kvalifikované osoby.
Προειδοποίηση	Η τοποθέτηση, η αντικατάσταση και η συντήρηση του εξοπλισμού επιτρέπεται να γίνονται μόνο από καταρτισμένο προσωπικό με τα κατάλληλα προσόντα.
אזהרה	רק עובדים מיומנים ומוסמכים רשאים להתקין, להחליף, או לטפל בציד זה.
Оророна	Местењето, заменувањето и сервисирањето на оваа опрема треба да му биде дозволено само на обучен и квалификуван персонал.
Ostrzeżenie	Do instalacji, wymiany i serwisowania tych urządzeń mogą być dopuszczone wyłącznie osoby wykwalifikowane i przeszkolone.
Upozornenie	Inštaláciu, výmenu alebo opravu tohto zariadenia smú vykonávať iba vyškolené a kvalifikované osoby.

## Statement 1040—Product Disposal



### Warning

**Ultimate disposal of this product should be handled according to all national laws and regulations.** Statement 1040

### Waarschuwing

**Het uiteindelijke wegruimen van dit product dient te geschieden in overeenstemming met alle nationale wetten en reglementen.**

### Varoitus

**Tämä tuote on hävitettävä kansallisten lakien ja määräysten mukaisesti.**

<b>Attention</b>	<b>La mise au rebut ou le recyclage de ce produit sont généralement soumis à des lois et/ou directives de respect de l'environnement. Renseignez-vous auprès de l'organisme compétent.</b>
<b>Warnung</b>	<b>Die Entsorgung dieses Produkts sollte gemäß allen Bestimmungen und Gesetzen des Landes erfolgen.</b>
<b>Avvertenza</b>	<b>Lo smaltimento di questo prodotto deve essere eseguito secondo le leggi e regolazioni locali.</b>
<b>Advarsel</b>	<b>Endelig kassering av dette produktet skal være i henhold til alle relevante nasjonale lover og bestemmelser.</b>
<b>Aviso</b>	<b>Deitar fora este produto em conformidade com todas as leis e regulamentos nacionais.</b>
<b>¡Advertencia!</b>	<b>Al deshacerse por completo de este producto debe seguir todas las leyes y reglamentos nacionales.</b>
<b>Varning!</b>	<b>Vid deponering hanteras produkten enligt gällande lagar och bestämmelser.</b>
<b>Aviso</b>	<b>O descarte definitivo deste produto deve estar de acordo com todas as leis e regulamentações nacionais.</b>
<b>Advarsel</b>	<b>Endelig bortskaffelse af dette produkt skal ske i henhold til gældende love og regler.</b>
<b>Figyelem</b>	<b>A készülék végső elhelyezéséről az adott országban érvényes törvények és előírások szerint kell intézkedni.</b>
<b>Предупреждение</b>	<b>Окончательная установка данного изделия должна выполняться в соответствии со всеми региональными и местными правилами и нормами.</b>
<b>警告</b>	<b>本产品的废弃处理应根据所有国家的法律和规章进行。</b>

警告 この製品を廃棄処分する際は、各国の法律および規制に従って取り扱ってください。

주의 해당 국가의 관련 법규 및 규정에 따라 이 장치를 폐기해야 합니다.

تحذير عند التخلص من المنتج يجب اتباع القوانين والتشريعات المحلية.

**Upozorenje** Zbrinjavanje ovoga proizvoda u otpad treba provesti u skladu s važećim zakonima i odredbama.

**Upozornění** **Upozornění:** Likvidace tohoto výrobku musí být provedena podle platných zákonů a předpisů.

Προειδοποίηση Η τελική απόρριψη αυτού του προϊόντος πρέπει να γίνεται σύμφωνα με όλους τους εθνικούς νόμους και κανονισμούς.

אזהרה סילוק סופי של מוצר זה חייב להיות בהתאם להנחיות ולחוקי המדינה.

Opomena Крајното фрлање на овој производ треба да се изврши во согласност со сите национални закони и прописи.

**Ostrzeżenie** **Ostateczna likwidacja tego urządzenia po jego wycofaniu z eksploatacji powinna odbywać się zgodnie z przepisami krajowymi.**

**Upozornenie** **Upozornenie** Likvidácia tohto výrobku musí byť vykonaná podľa platných zákonov a predpisov.

## Statement 1045—Short-circuit Protection



### Warning

**This product requires short-circuit (overcurrent) protection, to be provided as part of the building installation. Install only in accordance with national and local wiring regulations.** Statement 1045

### Waarschuwing

**Voor dit product moet kortsluitbeveiliging (overstroombeveiliging) deel uitmaken van de installatie in het gebouw. De installatie moet voldoen aan de nationale en lokale bedradingvoorschriften.**

### Varoitus

**Tämä tuote vaatii suojauksen oikosulkuja (ylivirtaa) vastaan osana asennusta rakennukseen. Asenna ainoastaan kansallisten ja paikallisten johdotussäännösten mukaisesti.**

### Attention

**La protection de ce produit contre les courts-circuits (surtensions) doit être assurée par la configuration électrique du bâtiment. Vérifiez que l'installation a lieu uniquement en conformité avec les normes de câblage en vigueur au niveau national et local.**

### Warnung

**Für dieses Produkt ist eine Kurzschlußsicherung (Überstromsicherung) erforderlich, die als Teil der Gebäudeinstallation zur Verfügung gestellt wird. Die Installation sollte nur in Übereinstimmung mit den nationalen und regionalen Vorschriften zur Verkabelung erfolgen.**

### Avvertenza

**Questo prodotto richiede una protezione contro i cortocircuiti, da fornirsi come parte integrante delle dotazioni presenti nell'edificio. Effettuare l'installazione rispettando le Norme CEI pertinenti.**

### Advarsel

**Dette produktet krever beskyttelse mot kortslutninger (overspenninger) som en del av installasjonen. Bare installer utstyret i henhold til nasjonale og lokale krav til ledningsnett.**

### Aviso

**Este produto requer proteção contra curto-circuitos (sobretensão de corrente), que deve estar instalada nos edifícios. Instale apenas de acordo com as normas de instalação elétrica nacionais e locais.**



<b>Advertencia</b>	<b>Este producto necesita estar conectado a la protección frente a cortacircuitos (sobretensiones) que exista en el edificio. Instálelo únicamente en conformidad con las regulaciones sobre cableado, tanto locales como nacionales, a las que se tenga que atender.</b>
<b>Varning!</b>	<b>Denna produkt kräver att kortslutningsskydd (överström) tillhandahålls som en del av byggnadsinstallationen. Installera bara i enlighet med nationella och lokala kabeldragningsbestämmelser.</b>
<b>Aviso</b>	<b>Este produto requer uma proteção contra curto-circuito (sobrecorrente) que deve fazer parte da instalação do edifício. Faça a instalação somente de acordo com as regulamentações de cabeamento nacionais e locais.</b>
<b>Advarsel</b>	<b>Dette produkt kræver beskyttelse mod kortslutning (overstrøm). Dette skal være en del elinstallationen i bygningen. Installation skal ske i overensstemmelse med nationale og lokale ledningsregler.</b>
<b>Figyelem</b>	<b>A termékhez kötelező rövidzárlat (túláram) elleni védelmet használni, amelyet az épület kábelezésének részeként kell biztosítani. Csak az országos és helyi kábelezési előírásoknak megfelelően helyezhető üzembe.</b>
<b>Предупреждение</b>	Для этого устройства необходима защита от короткого замыкания (перегрузки), являющаяся частью электропроводки здания. При установке устройства необходимо соблюдать региональные и местные требования к электрооборудованию.
<b>警告</b>	此产品需要短路（过载电流）保护，这种保护要由建筑物内的供电电路提供。安装时必须遵守国家 and 当地有关布线的规章。
<b>警告</b>	この製品は、設置する建物にショート（過電流）保護機構が備わっていることを前提に設計されています。電気配線に関する一般規定および地域の規定に従って設置してください。
<b>주의</b>	이 제품은 단락(과전류) 보호가 필요하며, 이는 건물 설치의 일부로 제공됩니다. 국가 및 해당 지역 배선 규정에 따라 설치하십시오.

## Translated Safety Warnings

تحذير يجب وجود حماية من الدوائر الكهربائية القصير كجزء من تركيب الجهاز. قم بالتركيب طبقاً للتشريعات السلكية المحلية.

**Upozorenje** Za ovaj je proizvod potrebna zaštita od prekomjerne količine struje (kratkoga spoja), koja mora biti ugrađena kao dio električnoga strujnog kruga. Zaštitu ugradite samo u skladu s važećim zakonima i propisima o ožičenju.

**Upozornění** **Upozornění:** Tento výrobek vyžaduje ochranu proti zkratu (nadproudu), která je součástí instalace budovy. Instalaci provádějte pouze v souladu s platnými předpisy pro elektroinstalaci.

Προειδοποίηση Αυτό το προϊόν απαιτεί στην κτιριακή εγκατάσταση να περιλαμβάνεται προστασία από βραχυκύκλωμα (υπέρ-ένταση). Η τοποθέτηση να γίνεται μόνο σύμφωνα με τους εθνικούς και τοπικούς κανονισμούς για την καλωδίωση.

אזהרה למוצר זה נדרשת הגנה מפני קצר (זרם-יתר), המסופקת כחלק ממערך ההתקנה. יש להתקין רק בהתאם להנחיות החיווט הנהוגות המדינה וההנחיות המקומיות.

Оромена За производот треба да се обезбеди заштита од краток spoj (преголем напон) што е вградена во инсталацијата на зградата. Местете ја инсталацијата само во согласност со националните и помесните прописи за електрично ожичување.

- Ostrzeżenie** To urządzenie wymaga zastosowania zabezpieczenia przeciwzwarciowego (nadprądowego) jako elementu instalacji elektrycznej budynku. Należy je instalować zgodnie z krajowymi i lokalnymi przepisami dotyczącymi instalacji elektrycznych.
- Upozornenie** Upozornenie Tento výrobok vyžaduje ochranu proti krátkemu spojeniu (nadprúdu), ktorá je súčasťou inštalácie budovy. Inštaláciu uskutočňujte iba v súlade s platnými predpismi pre elektroinštaláciu.
- 

## Statement 1051—Laser Radiation



### Warning

**Invisible laser radiation may be emitted from disconnected fibers or connectors. Do not stare into beams or view directly with optical instruments.**  
Statement 1051

### Waarschuwing

**Losgekoppelde of losgeraakte glasvezels of aansluitingen kunnen onzichtbare laserstraling produceren. Kijk niet rechtstreeks in de straling en gebruik geen optische instrumenten rond deze glasvezels of aansluitingen.**

### Varoitus

**Irrotetuista kuiduista tai liittimistä voi tulla näkymätöntä lasersäteilyä. Älä tuijota säteitä tai katso niitä suoraan optisilla välineillä.**

### Attention

**Les fibres ou connecteurs débranchés risquent d'émettre des rayonnements laser invisibles à l'œil. Ne regardez jamais directement les faisceaux laser à l'œil nu, ni d'ailleurs avec des instruments optiques.**

### Warnung

**Unterbrochene Fasern oder Steckverbindungen können unsichtbare Laserstrahlung abgeben. Blicken Sie weder mit bloßem Auge noch mit optischen Instrumenten direkt in Laserstrahlen.**

<b>Avvertenza</b>	<b>Le fibre ottiche ed i relativi connettori possono emettere radiazioni laser. I fasci di luce non devono mai essere osservati direttamente o attraverso strumenti ottici.</b>
<b>Advarsel</b>	<b>Det kan forekomme usynlig laserstråling fra fiber eller kontakter som er frakoblet. Stirr ikke direkte inn i strålene eller se på dem direkte gjennom et optisk instrument.</b>
<b>Aviso</b>	<b>Radiação laser invisível pode ser emitida de conectores ou fibras desconectadas. Não olhe diretamente para os feixes ou com instrumentos ópticos.</b>
<b>¡Advertencia!</b>	<b>Es posible que las fibras desconectadas emitan radiación láser invisible. No fije la vista en los rayos ni examine éstos con instrumentos ópticos.</b>
<b>Varning!</b>	<b>Osynlig laserstrålning kan avges från frånkopplade fibrer eller kontaktdon. Rikta inte blicken in i strålar och titta aldrig direkt på dem med hjälp av optiska instrument.</b>
<b>Aviso</b>	<b>Radiação laser invisível pode ser emitida a partir de fibras ou conectores desconectados. Não fixe o olhar nos feixes e nem olhe diretamente com instrumentos ópticos.</b>
<b>Advarsel</b>	<b>Usynlig laserstråling kan forekomme fra brukte fibre eller stik. Stir ikke ind i stråler eller direkte med optiske instrumenter.</b>
<b>Figyelem</b>	<b>A nem csatlakoztatott üvegszálak és csatlakozók láthatatlan lézersugárzást bocsáthatnak ki. Ne nézzen bele a sugárba, és ne nézze közvetlenül, optikai berendezések segítségével!</b>
<b>Предупреждение</b>	<b>Отключенные световоды и разъемы могут испускать невидимое лазерное излучение. Не допускайте попадания лазерного луча в глаза и не смотрите на него через оптические приборы.</b>
<b>警告</b>	<b>断开的光纤或接头有可能发出不可见的激光辐射。请勿直视光束或直接用光学仪器观看光束。</b>

**警告** 光ファイバ ケーブルまたはコネクタを取り外した状態では、目に見えないレーザー光が放射されていることがあります。光線をのぞきこんだり、光学機器を使用して光線を直接見たりしないでください。

**주의** 연결이 해제된 섬유나 커넥터에서 눈에 보이지 않는 레이저 방사열이 방출될 수 있습니다. 레이저 빔을 눈으로 쳐다 보거나 광학 기구를 사용하여 직접 보지 마십시오.

**تحذير** من المحتمل انبعاث أشعة الليزر من الألياف غير المتصلة أو التوصيلات. لا تتحدق النظر في الشعاع أو النظر مباشرة بدون أي أداة بصرية.

**Upozorenje** Postoji mogućnost laserskog zračenja iz iskopčanih vlakana ili priključaka. Nemojte gledati izravno u zrake niti ih promatrati optičkim instrumentima.

**Upozornění** Odpojená vlákna kabelů či konektory mohou vyzařovat neviditelné laserové záření. Nedívejte se do paprsků ani nepozorujte přímo pomocí optických přístrojů.

**Προειδοποίηση** Από αποσυνδεδεμένες ίνες ή υποδοχές μπορεί να εκπέμπεται αόρατη ακτινοβολία λέιζερ. Μην κοιτάτε απευθείας τις δέσμες φωτός και μην τις απεικονίζετε απευθείας με οπτικά όργανα.

**אזהרה** תתיכן פליטה של קרינת לייזר בלתי-נראית מסיבים או ממחברים מנותקים. אל תביט ישירות לתוך קרני אור ואל תביט באמצעות במכשירים אופטיים.

**Opomena** Невидливо ласерско зрачење може да зрачи од исклучените влакна или приклучоци. Не гледајте во зраци и не прегледувајте ги директно со оптички инструменти.

- Ostrzeżenie** Odłączone światłowody lub złącza mogą emitować niewidzialne promieniowanie laserowe. Nie należy patrzeć prosto w wiązkę lasera ani bezpośrednio obserwować jej przy użyciu przyrządów optycznych.
- Upozornenie** Odpojené vlákna káblov alebo konektory môžu vyžarovať neviditeľné laserové žiarenie. Nepozeraajte sa do lúčov ani ich nepozorujte priamo pomocou optických prístrojov.

## Statement 1074—Comply with Local and National Electrical Codes



### Warning

**Installation of the equipment must comply with local and national electrical codes.** Statement 1074

### Waarschuwing

**Bij installatie van de apparatuur moet worden voldaan aan de lokale en nationale elektriciteitsvoorschriften.**

### Varoitus

**Laitteisto tulee asentaa paikallisten ja kansallisten sähkömääräysten mukaisesti.**

### Attention

**L'équipement doit être installé conformément aux normes électriques nationales et locales.**

### Warnung

**Die Installation der Geräte muss den Sicherheitsstandards entsprechen.**

### Avvertenza

**L'installazione dell'impianto deve essere conforme ai codici elettrici locali e nazionali.**

### Advarsel

**Installasjon av utstyret må samsvare med lokale og nasjonale elektrisitetsforskrifter.**

Aviso	A instalação do equipamento tem de estar em conformidade com os códigos eléctricos locais e nacionais.
¡Advertencia!	La instalación del equipo debe cumplir con las normativas de electricidad locales y nacionales.
Varning!	Installation av utrustningen måste ske i enlighet med gällande elinstallationsföreskrifter.
Figyelem	A berendezés üzembe helyezését a helyi és a nemzeti elektromossági előírások figyelembevételével kell elvégezni.
Предупреждение	Установка оборудования должна соответствовать местным и национальным электротехническим нормам.
警告	设备安装必须符合本地与本国电气法规。
警告	機器の取り付けは地域および国内の電気工事規定に遵守する必要があります。

## Statement 1075—Hazardous Voltage or Energy Present on DC Power Terminals



### Warning

**Hazardous voltage or energy may be present on DC power terminals. Always replace cover when terminals are not in service. Be sure uninsulated conductors are not accessible when cover is in place.** Statement 1075

### Waarschuwing

**Op DC-aansluitingspunten kunnen zich gevaarlijke voltages of energieën voordoen. Plaats altijd de afsluiting wanneer de aansluitingspunten niet worden gebruikt. Zorg ervoor dat blootliggende contactpunten niet toegankelijk zijn wanneer de afsluiting is geplaatst.**

<b>Varoitus</b>	<b>Tasavirtaliittimissä saattaa olla huomattava jännite tai teho. Sulje suojus aina, kun liittimet eivät ole käytössä. Suojuksen ollessa suljettuna varmista, että kohde on suojattu eristämättömiltä johtimilta.</b>
<b>Attention</b>	<b>Le voltage ou l'énergie électrique des terminaux à courant continu peuvent être dangereux. Veuillez à toujours replacer le couvercle lors les terminaux ne sont pas en service. Assurez-vous que les conducteurs non isolés ne sont pas accessibles lorsque le couvercle est en place.</b>
<b>Warnung</b>	<b>In mit Gleichstrom betriebenen Terminals kann es zu gefährlicher Spannung kommen. Die Terminals müssen abgedeckt werden, wenn sie nicht in Betrieb sind. Stellen Sie bei Benutzung der Abdeckung sicher, dass alle nicht isolierten, stromführenden Kabel abgedeckt sind.</b>
<b>Avvertenza</b>	<b>I terminali di alimentazione DC potrebbero contenere voltaggio o energia pericolosi. Accertarsi di sostituire il coperchio ogni qualvolta i terminali non sono operativi. Accertarsi che i conduttori scoperti non siano accessibili quando il coperchio è inserito.</b>
<b>Advarsel</b>	<b>Det kan forekomme farlig spenning eller energi i likestrømsterminaler. Sett alltid dekselet på plass når terminalene ikke er i bruk. Kontroller at uisolerte ledere ikke er tilgjengelige når dekselet er på plass.</b>
<b>Aviso</b>	<b>Os terminais de corrente contínua podem fornecer tensão ou energia perigosa. Volte a colocar a tampa, sempre que os terminais não estiverem a ser utilizados. Certifique-se de que os condutores sem isolamento não estão acessíveis, quando a tampa estiver colocada.</b>
<b>¡Advertencia!</b>	<b>Puede haber energía o voltaje peligrosos en los terminales eléctricos de CC. Reemplace siempre la cubierta cuando no estén utilizándose los terminales. Asegúrese de que no haya acceso a conductores descubiertos cuando la cubierta esté colocada.</b>
<b>Varning!</b>	<b>Farlig spänning eller skadlig energi kan finnas i likströmsterminalerna. Sätt alltid tillbaka höljet när terminalerna inte används. Försäkra att inga oisolerade ledare kan nås när höljet sitter på plats.</b>



**Figyelem** Az egyenáramú csatlakozókon veszélyes feszültség vagy energia léphet fel. Ha a csatlakozók nincsenek bekötve, feltétlenül tegye vissza a fedelet. Ügyeljen rá, hogy a szigetetlen vezetőkeket ne lehessen megérinteni, ha a fedél fel van szerelve.

**Предупреждение** На контактах питания постоянного тока может присутствовать опасное напряжение или энергия. Всегда устанавливайте крышку на место после завершения обслуживания. Когда крышка установлена, все неизолированные проводники должны быть недоступны.

**警告** 直流电源终端可能产生危险的电压或能量。终端不使用时，务必将机盖盖上。确认机盖盖上时，无法使用不绝缘导体。

**警告** 直流電力端子に危険な電圧やエネルギーが発生している可能性があります。使用していない端子には常にカバーを付けてください。カバーが付いているときは非絶縁形コンダクタに接触できないことを確認してください。

## Regulatory Standards Compliance

This section includes all regulatory, safety, EMC (Class A or Class B), telecomm, and NEBS standards. The Catalyst 4948, Catalyst 4948-10GE, and Catalyst 4928-10GE switches are in compliance with national and international standards as described in Table C-1.

**Table C-1** Class A Regulatory Standards Compliance

Specification	Standard
Regulatory Compliance	Products with the CE Marking indicate compliance with the 1999/5/EC directive, which includes the safety and EMC standards listed.
Safety	UL 60950-1 CAN/CSA-C22.2 No. 60950-1

**Table C-1 Class A Regulatory Standards Compliance (continued)**

<b>Specification</b>	<b>Standard</b>
	EN 60950-1 IEC 60950-1 AS/NZS 60950-1
EMC	FCC Part 15 (CFR 47) Class A ICES-003 Class A EN50082-1 CISPR22 Class A AS/NZS CISPR22 Class A VCCI Class A EN55022 Class A EN55024 EN61000-3-2 EN6100-3-3 EN61000-6-1 EN300 386 KN22 Class A KN immunity series CISPR24

**Table C-2 Industry EMC, Safety, and Environmental Standards**

<b>Specification</b>	<b>Standard</b>
NEBS Criteria Levels	SR-3580 NEBS level 3 (GRC-63-CORE issue 3, GR-1089-CORE , issue 4
Verizon NEBS Compliance	Telecommunications Carrier Group (TCG) Checklist

**Table C-2** *Industry EMC, Safety, and Environmental Standards (continued)*

<b>Specification</b>	<b>Standard</b>
Qwest NEBS Compliance	TCG Checklist
ATT NEBS requirements	ATT TP76200 level 3 and TCG Checklist
ETSI	ETS 300 019-2-1, Class 1.1 Storage ETS 300 019-2-2, Class 2.1 and 2.2 Transportation ETS 300 019-2-3, Class 3.1E Stationary Use

**Table C-3** *GR-1089 Installation and Caution Instructions*

---

Shielded cable grounded at both ends specified for copper telecom ports.

---

**Caution**

The intra-building port(s) of the equipment or subassembly is suitable for connection to intra-building or unexposed wiring or cabling only. The intra-building port(s) of the equipment or subassembly must not be metallically connected to interfaces which connect to the OSP or its wiring. These interfaces are designed for use as intra-building interfaces only (Type 2 or Type 4 ports as described in GR-1089-CORE, Issue 4) and require isolation from the exposed OSP cabling. The addition of primary protectors is not sufficient protection in order to connect these interfaces metallically to OSP wiring.

---

The Catalyst 4900 Series Switches have AC power ports that are intended for deployments where an external Surge Protective Device (SPD) is utilized at the AC power service equipment (see definition in National Electric Code).

---

The Catalyst 4900 Series Switches are designed for a Common Bonding Network (CBN) installation.

---

The Catalyst 4900 Series Switches can be installed in network telecommunication facilities or locations where the National Electric Code applies.

---

**Table C-3 GR-1089 Installation and Caution Instructions (continued)**

---

An electrical conducting path shall exist between the product chassis and the metal surface of the enclosure or rack in which it is mounted or to a grounding conductor. Electrical continuity shall be provided by using thread-forming type mounting screws that remove any paint or nonconductive coatings and establish a metal-to-metal contact. Any paint or other nonconductive coatings shall be removed on the surfaces between the mounting hardware and the enclosure or rack. The surfaces shall be cleaned and an antioxidant applied before installation.

---

The DC return connection to this system should remain Isolated from the system frame and chassis (DC-I).

---

The nominal DC operating voltage is -48V DC.

---

## European Directives

### Statement 287—Declaration of Conformity to R&TTE Directive 1999/5/EC for the European Community, Switzerland, Norway, Iceland and Liechtenstein

**English:** This equipment is in compliance with the essential requirements and other relevant provisions of Directive 1999/5/EC.

**Български:** Това оборудване отговаря на съществените изисквания и приложими к  
**[Bulgarian]:** Директива 1999/5/EC.

**Česky**  
**[Czech]:** Toto zařízení je v souladu se základními požadavky a ostatními odpovídajíc ustanoveními Směrnice 1999/5/EC.

**Dansk**  
**[Danish]:** Dette udstyr er i overensstemmelse med de væsentlige krav og andre relevante bestemmelser i Direktiv 1999/5/EF.

<b>Deutsch</b> [German]:	<b>Dieses Gerät entspricht den grundlegenden Anforderungen und den weiteren entsprechenden Vorgaben der Richtlinie 1999/5/EU.</b>
<b>Eesti</b> [Estonian]:	<b>See seade vastab direktiivi 1999/5/EÜ olulistele nõuetele ja teistele asjakohastele sätetele.</b>
<b>Español</b> [Spanish]:	<b>Este equipo cumple con los requisitos esenciales así como con otras disposiciones de la Directiva 1999/5/CE.</b>
<b>Ελληνική</b> [Greek]:	<b>Αυτός ο εξοπλισμός είναι σε συμμόρφωση με τις ουσιώδεις απαιτήσεις και διατάξεις της Οδηγίας 1999/5/EC.</b>
<b>Français</b> [French]:	<b>Cet appareil est conforme aux exigences essentielles et aux autres dispositions pertinentes de la Directive 1999/5/EC.</b>
<b>Íslenska</b> [Icelandic]:	<b>Þetta tæki er samkvæmt grunnkröfum og öðrum viðeigandi ákvæðum Tilskipunar 1999/5/EC.</b>
<b>Italiano</b> [Italian]:	<b>Questo apparato é conforme ai requisiti essenziali ed agli altri principi sanciti dalla Direttiva 1999/5/CE.</b>
<b>Latviski</b> [Latvian]:	<b>Šī iekārta atbilst Direktīvas 1999/5/EK būtiskajām prasībām un citiem ar to saistītajiem noteikumiem.</b>
<b>Lietuvių</b> [Lithuanian]:	<b>Šis įrenginys tenkina 1999/5/EB Direktyvos esminius reikalavimus ir kitas š direktyvos nuostatas.</b>
<b>Nederlands</b> [Dutch]:	<b>Dit apparaat voldoet aan de essentiële eisen en andere van toepassing zijnde bepalingen van de Richtlijn 1999/5/EC.</b>
<b>Malti</b> [Maltese]:	<b>Dan l-apparat huwa konformi mal-htigiet essenzjali u l-provedimenti l-ohra rilevanti tad</b>
<b>Magyar</b> [Hungarian]:	<b>Ez a készülék teljesíti az alapvető követelményeket és más 1999/5/EK irányú meghatározott vonatkozó rendelkezéseket.</b>
<b>Norsk</b> [Norwegian]:	<b>Dette utstyret er i samsvar med de grunnleggende krav og andre relevante bestemmelser i EU-direktiv 1999/5/EF.</b>

<b>Polski</b> [Polish]:	Urządzenie jest zgodne z ogólnymi wymaganiami oraz szczególnymi warunkami Dyrektywą UE: 1999/5/EC.
<b>Português</b> [Portuguese]:	Este equipamento está em conformidade com os requisitos essenciais e outras provisões relevantes da Directiva 1999/5/EC.
<b>Română</b> [Romanian]:	Acest echipament este în conformitate cu cerințele esențiale și cu alte prevederi relevante ale Directivei 1999/5/EC.
<b>Slovensko</b> [Slovenian]:	Ta naprava je skladna z bistvenimi zahtevami in ostalimi relevantnimi pogoji Direktive 1999/5/EC.
<b>Slovensky</b> [Slovak]:	Toto zariadenie je v zhode so základnými požiadavkami a inými príslušnými nariadeniami direktív: 1999/5/EC.
<b>Suomi</b> [Finnish]:	Tämä laite täyttää direktiivin 1999/5/EY olennaiset vaatimukset ja on siinä asiantuntijalaitetta koskevien määräysten mukainen.
<b>Svenska</b> [Swedish]:	Denna utrustning är i överensstämmelse med de väsentliga kraven och andra bestämmelser i Direktiv 1999/5/EC.

## Statement 275—Declaration of Conformity with Regard to the Directives 73/23/EEC and 89/336/EEC as amended by Directive 93/68/EEC

For specifics about which standards have been applied, refer to the Declaration of Conformity.

- English:** This equipment is in compliance with the essential requirements and other provisions of Directives 73/23/EEC and 89/336/EEC as amended by Directive 93/68/EEC.
- Dansk:** Dette udstyr er i overensstemmelse med de ufravigelige hensyn og andre bestemmelser i direktiv 73/23/EEC og 89/336/EEC som ændret i direktiv 93/68/EEC.
- Deutsch:** Dieses Gerät entspricht den wesentlichen Anforderungen und weiteren Bestimmungen der Richtlinien 73/23/EWG und 89/336/EWG mit der Ergänzung durch Richtlinie 93/68/EWG.
- Español:** Este equipo cumple con los requisitos esenciales y otras disposiciones de las Directrices 73/23/EEC y 89/336/EEC de acuerdo a las modificaciones de la Directriz 93/68/EEC.
- Ελληνική:** Αυτός ο εξοπλισμός συμμορφώνεται με τις ουσιαστικές απαιτήσεις και τις λοιπές διατάξεις των Οδηγιών 73/23/ΕΟΚ και 89/336/ΕΟΚ, όπως τροποποιήθηκαν με την Οδηγία 93/68/ΕΟΚ.
- Français:** Cet appareil remplit les principales conditions requises et autres dispositions des Directives 73/23/EEC et 89/336/EEC, modifiées par la Directive 93/68/EEC.
- Íslenska:** Þessi búnaður samrýmist lögboðnum kröfum og öðrum ákvæðum tilskipana 73/23/EBE og 89/336/EBE, með breytingum skv. tilskipun 93/68/EBE.
- Italiano:** Questa apparecchiatura è conforme ai requisiti essenziali e altre disposizioni delle Direttive 73/23/EEC e 89/336/EEC modificate con la Direttiva 93/68/EEC.
- Nederlands:** Deze apparatuur voldoet aan de belangrijkste eisen en andere voorzieningen van richtlijnen 73/23/EEC en 89/336/EEC zoals gewijzigd door richtlijn 93/68/EEC.
- Norsk:** Dette utstyret samsvarer med de vesentligste kravene og andre regler i direktivene 73/23/EEC og 89/336/EEC samt i tilleggsdirektiv 93/68/EEC.
- Português:** Este equipamento satisfaz os requisitos essenciais e outras provisões das Directivas 73/23/EEC e 89/336/EEC, conforme amendados pela Directiva 93/68/EEC.

- Română** Prin prezenta, noi Cisco Systems România SRL, declarăm pe propria răspundere că produsul de mai jos, îndeplinește principalele cerințe de conformitate cu Directiva Europeană 89/336/EEC, 73/23/EEC(R&TTE)  
**Catalyst 4948 and Catalyst 4948-10GE switches**
- Suomalainen:** **Tämä laite on direktiivien 73/23/ETY ja 89/336/ETY (kuten muutettu direktiivissä 93/68/ETY) keskeisten vaatimusten ja määräysten mukainen.**
- Svenska:** **Denna utrustning uppfyller de väsentliga kraven och andra villkor i direktiven 73/23/EEC och 89/336/EEC enligt ändringarna i direktiv 93/68/EEC.**

## California Perchlorate Contamination Prevention Act (Title 22, California Code of Regulations, Chapter 33)

The battery inside this product might contain perchlorate, a known hazardous substance, so special handling and disposal of this product might be necessary. For more information about perchlorate and best management practices for perchlorate-containing substances, see <http://www.dtsc.ca.gov/HazardousWaste/Perchlorate/index.cfm>.

## EMC Class A Notices and Warnings

This section includes the EMC Class A warnings for the Catalyst 4948 and Catalyst 4948-10GE switches.

### Class A Notice for FCC

Modifying the equipment without Cisco's authorization may result in the equipment no longer complying with FCC requirements for Class A digital devices. In that event, your right to use the equipment may be limited by FCC regulations, and you may be required to correct any interference to radio or television communications at your own expense.



This equipment has been tested and found to comply with the limits for a Class A digital device, pursuant to Part 15 of the FCC Rules. These limits are designed to provide reasonable protection against harmful interference when the equipment is operated in a commercial environment. This equipment generates, uses, and can radiate radio frequency energy and, if not installed and used in accordance with the instruction manual, may cause harmful interference to radio communications. Operation of this equipment in a residential area is likely to cause harmful interference in which case users will be required to correct the interference at their own expense.

## Class A Notice for Canada

This Class A digital apparatus complies with Canadian ICES-003.

Cet appareil numérique de la classe A est conforme à la norme NMB-003 du Canada.

## Statement 340—Class A Warning for CISPR22



Warning

**This is a class A product. In a domestic environment this product may cause radio interference in which case the user may be required to take adequate measures.** Statement 340

Waarschuwing

**Dit is een product van klasse A. In een woonomgeving kan dit product radiostoring veroorzaken. In dat geval moet de gebruiker de juiste maatregelen nemen.**

Varoitus

**Tämä on A-luokan tuote. Kotona käytettynä tämä tuote voi aiheuttaa radiotaajuushäiriöitä, jolloin käyttäjän tulisi ryhtyä vaadittaviin toimenpiteisiin häiriöiden ehkäisemiseksi.**

Attention

**Il s'agit d'un produit de classe A. Dans un environnement local, ce produit peut entraîner des perturbations radioélectriques, auquel cas l'utilisateur devra éventuellement prendre des mesures adéquates.**

## EMC Class A Notices and Warnings

<b>Warnung</b>	<b>Dies ist ein Produkt der Klasse A. Bei der Verwendung dieses Produkts im Haus- oder Wohnbereich kann es zu Funkstörungen kommen. In diesem Fall muss der Benutzer u. U. angemessene Maßnahmen ergreifen.</b>
<b>Avvertenza</b>	<b>Prodotto di classe A. È possibile che il prodotto generi interferenze radio in un ambienti chiusi. In questo caso l'utente deve intraprendere le misure adeguate per risolvere il problema.</b>
<b>Advarsel</b>	<b>Dette er et produkt i klasse A. I et hjemmemiljø kan dette produktet forårsake radioforstyrrelser, og brukeren kan da være nødt til å ta de nødvendige forholdsregler.</b>
<b>Aviso</b>	<b>Este é um produto de classe A. Em um ambiente doméstico, este produto pode causar interferência de rádio. Nesse caso, talvez o usuário precise tomar as medidas adequadas.</b>
<b>¡Advertencia!</b>	<b>Este es un producto de clase A. En el ámbito doméstico, este producto puede causar radiointerferencias, lo que puede hacer necesaria la puesta en marcha de medidas adecuadas.</b>
<b>Varning!</b>	<b>Detta är en klass A-produkt. Denna produkt kan orsaka radiostörningar inomhus. Det kan då vara ett krav att användaren vidtar lämpliga åtgärder.</b>
<b>Figyelem</b>	<b>Ez egy A osztályba tartozó termék. Lakáson belüli környezetben előfordulhat, hogy a termék rádióvédelmi interferenciát okoz; ilyen esetben megfelelő lépéseket kell tenni a zavar megszüntetése érdekében.</b>
<b>Предупреждение</b>	<b>Данное изделие относится к классу А. При установке в жилых помещениях данное изделие может стать причиной радиопомех, в результате чего пользователю может потребоваться предпринять соответствующие меры.</b>
<b>警告</b>	<b>这是类别 A 产品。在家用环境中，该产品可能会引起无线电干扰，此时用户需要采取适当措施。</b>

**警告** この装置はクラスA製品です。この装置を住宅地で使用した場合、電波妨害を引き起こすことがあります。その場合、ユーザが適切な防止措置を講じるよう求められることがあります。

**Upozornění** Toto je produkt třídy A. V domácím prostředí může způsobovat rušení rádiových vln. V takovém případě musí uživatel provést příslušná opatření.

**Προειδοποίηση** Αυτό είναι ένα προϊόν κλάσης A. Σε οικιακό περιβάλλον, αυτό το προϊόν ενδέχεται να προκαλέσει παρεμβολές ("παράσιτα") και σε μια τέτοια περίπτωση ο χρήστης ενδέχεται να χρειαστεί να λάβει τα κατάλληλα μέτρα.

**Ostrzeżenie** Jest to produkt klasy A. W środowisku domowym produkt ten może powodować zakłócenia radiowe, wymagające od użytkownika podjęcia odpowiednich czynności zaradczych.

**Upozornenie** Toto je výrobok triedy A. Tento výrobok môže v domácom prostredí spôsobovať rádiové rušenie a v takom prípade sa môže vyžadovať, aby jeho používateľ vykonal adekvátne opatrenia.

**Opozorilo** Izdelek spada v razred A. Uporaba izdelka lahko v domačem okolju povzroči radijske motnje, pri čemer je včasih treba ustrezno ukrepati.

---

## Statement 191—VCCI Class A Warning for Japan

**Warning**

**This is a Class A product based on the standard of the Voluntary Control Council for Interference by Information Technology Equipment (VCCI). If this equipment is used in a domestic environment, radio disturbance may arise. When such trouble occurs, the user may be required to take corrective actions.**

**警告**

VCCI 準拠クラスA機器（日本）  
この装置は、情報処理装置等電波障害自主規制協議会（VCCI）の基準に基づくクラスA情報技術装置です。この装置を家庭環境で使用すると電波妨害を引き起こすことがあります。この場合には使用者が適切な対策を講ずるよう要求されることがあります。

## Statement 256—Class A Warning for Hungary



**Warning**

**This equipment is a class A product and should be used and installed properly according to the Hungarian EMC Class A requirements (MSZEN55022). Class A equipment is designed for typical commercial establishments for which special conditions of installation and protection distance are used.**

**Figyelem**

**Figyelmeztetés a felhasználói kézikönyv számára: Ez a berendezés "A" osztályú termék, felhasználására és üzembe helyezésére a magyar EMC "A" osztályú követelményeknek (MSZ EN 55022) megfelelően kerülhet sor, illetve ezen "A" osztályú berendezések csak megfelelő kereskedelmi forrásból származhatnak, amelyek biztosítják a megfelelő speciális üzembe helyezési körülményeket és biztonságos üzemelési távolságok alkalmazását.**

## Statement 294—Class A Warning for Korea



**Warning**

**This is a Class A Device and is registered for EMC requirements for industrial use. The seller or buyer should be aware of this. If this type was sold or purchased by mistake, it should be replaced with a residential-use type.**

**주의**

**A급 기기 이 기기는 업무용으로 전자파 적합 등록을 한 기기이오니 판매자 또는 사용자는 이 점을 주의하시기 바라며 만약 잘못 판매 또는 구입하였을 때에는 가정용으로 교환하시기 바랍니다.**

## Statement 257—Class A Notice for Taiwan and Other Traditional Chinese Markets

**Warning**

**This is a Class A Information Product, when used in residential environment, it may cause radio frequency interference, under such circumstances, the user may be requested to take appropriate countermeasures.** Statement 257

**警告**

這是甲類資訊產品，在居住環境中使用時，可能會造成射頻干擾，在這種情況下，使用者會被要求採取某些適當的對策。

## Statement 371—Power Cable and AC Adapter

接続ケーブル、電源コード、ACアダプタなどの部品は、必ず添付品または指定品をご使用ください。添付品・指定品以外の部品をご使用になると故障や動作不良、火災の原因となります。また、電気用品安全法により、当該法の認定（PSEとコードに表記）でなくUL認定（ULとコードに表記）の電源ケーブルは弊社が指定する製品以外の電気機器には使用できないためご注意ください。



## INDEX

### Numerics

---

1000 W power supplies  
    power cords (table) **2-5**

### A

---

accessory kit contents **3-2**  
AC-input power cords  
    product numbers (table) **2-5**  
airflow  
    site environment **2-2**  
    within the chassis **1-11**  
alternative wiring **4-1**

### B

---

blank faceplate **1-13**  
brackets  
    cable **3-8**  
    mounting **3-6**

### C

---

cable guide **3-8**  
chassis  
    dimensions **A-3**  
    weight **A-3**  
checklist, site planning **2-9**  
cleaning guidelines **4-7**  
console port **1-7**  
    connecting to **B-2**  
    location **1-7**  
    pinouts **A-1**  
customer service **5-6**

### D

---

dimensions, chassis **A-3**  
documentation  
    audience **i-ix**  
    conventions **i-xi**  
    organization **i-ix**  
    related **i-x**

**E**

electrostatic discharge (ESD) **2-9**  
 EMI recommendations **2-4**  
 environmental requirements **2-1**

**F**

fan tray  
     cooling **1-11**  
     failure **1-12**  
     status LED **1-11**

fiber-optic connectors **4-7**

**G**

grounding requirement, DC systems **2-6**

**H**

hardware description  
     power supply **1-12**  
 heat dissipation  
     determining **2-4**

**I**

installation  
     connecting to a power source **B-3**

starting the terminal-emulation  
 software **B-3**

installing the switch

    guidelines **3-2**  
     lifting **3-5**  
     procedure **3-6**  
     safety overview **2-7**  
     tools required **3-5**  
     troubleshooting **5-1**

**L**

label, chassis serial number **5-6**

LEDs

    locations **1-9**  
     meanings **1-10**  
     POST results **B-4**  
     power supply **5-3**

**M**

management port pinout **A-2**

memory **A-3**

MT-RJ connectors

    cleaning **4-6**

**P**

pinout

    management port **A-2**



port status LED **1-10**

## POST

LEDs **B-4**

## power

connecting **3-9, 3-11**

DC grounding requirements **2-6**

determining power requirements and heat dissipation **2-4**

EMI recommendations **2-4**

general requirements **2-3**

management **1-14**

specifications **A-3**

troubleshooting **5-2**

warnings and cautions **2-3**

## power supply

environmental monitoring **1-13**

LEDs **1-11, 5-3**

overview **1-12**

redundancy **1-13**

specifications **A-4**

troubleshooting **5-4, 5-5**

## R

rack-mounting **3-2**

## redundancy

power supply **1-13**

## S

### safety

ensuring safety **2-7**

overview **2-7**

translated safety warnings **C-2**

screws **3-6**

serial number, chassis **5-6**

### site planning

checklist **2-9**

DC grounding requirement **2-6**

EMI recommendations **2-4**

environmental requirements **2-1**

general requirements **2-3**

overview **2-1**

warnings and cautions **2-3**

software documentation **i-x**

### specifications

AC Power **A-3**

DC Power **A-4**

environmental **A-3**

switching components **A-3**

startup sequence **5-3**

status LED **1-10**

system specifications **A-1**

## T

temperature thresholds **2-2**

terminal-emulation software **B-3**

traffic ports **1-7**

troubleshooting

    contacting customer service **5-6**

    initial boot **5-2**

    methodology **5-2**

    power supply **5-4, 5-5**

    startup **5-3**

typographical conventions **i-xi**

## **W**

---

warnings

    translated safety **C-2**

weight

    chassis **A-3**