



Configuring Interface Characteristics

- [Information About Interface Characteristics, on page 1](#)
- [How to Configure Interface Characteristics, on page 14](#)
- [Configuration Examples for Interface Characteristics, on page 65](#)
- [Additional References for Configuring Interface Characteristics, on page 75](#)
- [Feature History for Configuring Interface Characteristics, on page 75](#)

Information About Interface Characteristics

The following sections provide information about interface characteristics.

Interface Types

This section describes the different types of interfaces supported by the device. The rest of the chapter describes configuration procedures for physical interface characteristics.

Port-Based VLANs

A VLAN is a switched network that is logically segmented by function, team, or application, without regard to the physical location of the users. Packets received on a port are forwarded only to ports that belong to the same VLAN as the receiving port. Network devices in different VLANs cannot communicate with one another without a Layer 3 device to route traffic between the VLANs.

VLAN partitions provide hard firewalls for traffic in the VLAN, and each VLAN has its own MAC address table. A VLAN comes into existence when a local port is configured to be associated with the VLAN, when the VLAN Trunking Protocol (VTP) learns of its existence from a neighbor on a trunk, or when a user creates a VLAN.

To configure VLANs, use the **vlan** *vlan-id* global configuration command to enter VLAN configuration mode. The VLAN configurations for normal-range VLANs (VLAN IDs 1 to 1005) are saved in the VLAN database. If VTP is version 1 or 2, to configure extended-range VLANs (VLAN IDs 1006 to 4094), you must first set VTP mode to transparent. Extended-range VLANs created in transparent mode are not added to the VLAN database but are saved in the running configuration. With VTP version 3, you can create extended-range VLANs in client or server mode in addition to transparent mode. These VLANs are saved in the VLAN database.

Add ports to a VLAN by using the **switchport** command in interface configuration mode.

- Identify the interface.
- For a trunk port, set trunk characteristics, and, if desired, define the VLANs to which it can belong.
- For an access port, set and define the VLAN to which it belongs.

Switch Ports

Switch ports are Layer 2-only interfaces associated with a physical port. Switch ports belong to one or more VLANs. A switch port can be an access port or a trunk port. You can configure a port as an access port or trunk port or let the Dynamic Trunking Protocol (DTP) operate on a per-port basis to set the switchport mode by negotiating with the port on the other end of the link. Switch ports are used for managing the physical interface and associated Layer 2 protocols and do not handle routing or bridging.

Configure switch ports by using the **switchport** interface configuration commands.

Access Ports

An access port belongs to and carries the traffic of only one VLAN (unless it is configured as a voice VLAN port). Traffic is received and sent in native formats with no VLAN tagging. Traffic arriving on an access port is assumed to belong to the VLAN assigned to the port. If an access port receives a tagged packet (Inter-Switch Link [ISL] or IEEE 802.1Q tagged), the packet is dropped, and the source address is not learned.

The types of access ports supported are:

- Static access ports are manually assigned to a VLAN (or through a RADIUS server for use with IEEE 802.1x).

You can also configure an access port with an attached Cisco IP Phone to use one VLAN for voice traffic and another VLAN for data traffic from a device attached to the phone.

Trunk Ports

A trunk port carries the traffic of multiple VLANs and by default is a member of all VLANs in the VLAN database. The IEEE 802.1Q trunk port type is supported. An IEEE 802.1Q trunk port supports simultaneous tagged and untagged traffic. An IEEE 802.1Q trunk port is assigned a default port VLAN ID (PVID), and all untagged traffic travels on the port default PVID. All untagged traffic and tagged traffic with a NULL VLAN ID are assumed to belong to the port default PVID. A packet with a VLAN ID equal to the outgoing port default PVID is sent untagged. All other traffic is sent with a VLAN tag.

Although by default, a trunk port is a member of every VLAN known to the VTP, you can limit VLAN membership by configuring an allowed list of VLANs for each trunk port. The list of allowed VLANs does not affect any other port but the associated trunk port. By default, all possible VLANs (VLAN ID 1 to 4094) are in the allowed list. A trunk port can become a member of a VLAN only if VTP knows of the VLAN and if the VLAN is in the enabled state. If VTP learns of a new, enabled VLAN and the VLAN is in the allowed list for a trunk port, the trunk port automatically becomes a member of that VLAN and traffic is forwarded to and from the trunk port for that VLAN. If VTP learns of a new, enabled VLAN that is not in the allowed list for a trunk port, the port does not become a member of the VLAN, and no traffic for the VLAN is forwarded to or from the port.

Tunnel Ports

Tunnel ports are used in IEEE 802.1Q tunneling to segregate the traffic of customers in a service-provider network from other customers who are using the same VLAN number. You configure an asymmetric link from a tunnel port on a service-provider edge switch to an IEEE 802.1Q trunk port on the customer switch.

Packets entering the tunnel port on the edge switch, already IEEE 802.1Q-tagged with the customer VLANs, are encapsulated with another layer of an IEEE 802.1Q tag (called the metro tag), containing a VLAN ID unique in the service-provider network, for each customer. The double-tagged packets go through the service-provider network keeping the original customer VLANs separate from those of other customers. At the outbound interface, also a tunnel port, the metro tag is removed, and the original VLAN numbers from the customer network are retrieved.

Tunnel ports cannot be trunk ports or access ports and must belong to a VLAN unique to each customer.

Routed Ports

A routed port is a physical port that acts like a port on a router; it does not have to be connected to a router. A routed port is not associated with a particular VLAN, as is an access port. A routed port behaves like a regular router interface, except that it does not support VLAN subinterfaces. Routed ports can be configured with a Layer 3 routing protocol. A routed port is a Layer 3 interface only and does not support Layer 2 protocols, such as DTP and STP.

Configure routed ports by putting the interface into Layer 3 mode with the **no switchport** interface configuration command. Then assign an IP address to the port, enable routing, and assign routing protocol characteristics by using the **ip routing** and **router protocol** global configuration commands.



Note Entering a **no switchport** interface configuration command shuts down the interface and then re-enables it, which might generate messages on the device to which the interface is connected. When you put an interface that is in Layer 2 mode into Layer 3 mode, the previous configuration information related to the affected interface might be lost.



Note A port configured as a switchport does not support MAC address configuration. It does not support the **mac-address x.x.x** command.

The number of routed ports that you can configure is not limited by software. However, the interrelationship between this number and the number of other features being configured might impact CPU performance because of hardware limitations.

Switch Virtual Interfaces

A switch virtual interface (SVI) represents a VLAN of switch ports as one interface to the routing function in the system. You can associate only one SVI with a VLAN. You configure an SVI for a VLAN only to route between VLANs or to provide IP host connectivity to the device. By default, an SVI is created for the default VLAN (VLAN 1) to permit remote device administration. Additional SVIs must be explicitly configured.



Note You cannot delete interface VLAN 1.

SVIs provide IP host connectivity only to the system. SVIs are created the first time that you enter the **vlan** interface configuration command for a VLAN interface. The VLAN corresponds to the VLAN tag associated with data frames on an ISL or IEEE 802.1Q encapsulated trunk or the VLAN ID configured for an access port. Configure a VLAN interface for each VLAN for which you want to route traffic, and assign it an IP address.

You can also use the interface range command to configure existing VLAN SVIs within the range. The commands entered under the interface range command are applied to all existing VLAN SVIs within the range. You can enter the command **interface range create vlan** *x - y* to create all VLANs in the specified range that do not already exist. When the VLAN interface is created, **interface range vlan** *id* can be used to configure the VLAN interface.

Although the device supports a total of 1005 VLANs and SVIs, the interrelationship between the number of SVIs and routed ports and the number of other features being configured might impact CPU performance because of hardware limitations.

When you create an SVI, it does not become active until it is associated with a physical port.

EtherChannel Port Groups

EtherChannel port groups treat multiple switch ports as one switch port. These port groups act as a single logical port for high-bandwidth connections between devices or between devices and servers. An EtherChannel balances the traffic load across the links in the channel. If a link within the EtherChannel fails, traffic previously carried over the failed link changes to the remaining links. You can group multiple trunk ports into one logical trunk port, group multiple access ports into one logical access port, group multiple tunnel ports into one logical tunnel port, or group multiple routed ports into one logical routed port. Most protocols operate over either single ports or aggregated switch ports and do not recognize the physical ports within the port group. Exceptions are the DTP, the Cisco Discovery Protocol (CDP), and the Port Aggregation Protocol (PAgP), which operate only on physical ports.

When you configure an EtherChannel, you create a port-channel logical interface and assign an interface to the EtherChannel. For Layer 3 interfaces, you manually create the logical interface by using the **interface port-channel** global configuration command. Then you manually assign an interface to the EtherChannel by using the **channel-group** interface configuration command. For Layer 2 interfaces, use the **channel-group** interface configuration command to dynamically create the port-channel logical interface. This command binds the physical and logical ports together.

Network Modules

The device supports two network modules that include 10-Gigabit Ethernet and 40-Gigabit Ethernet uplink ports. Though they are named Ethernet, all ports are only fiber ports.

The following are the network modules supported:

- 8x10G
- 2x40G



Note This is applicable only on C9500-16X and C9500-40X models of the Cisco Catalyst 9500 Series Switches.

Using the Switch USB Ports

The device has two USB ports on the front panel: a USB mini-Type B console port and a USB 2.0 host port and a USB 3.0 port on the rear panel. Note that the Cisco Catalyst 9500 Series Switches - High Performance do not have a USB port on the rear.

USB Mini-Type B Console Port

The device has the following console ports:

- USB mini-Type B console connection
- RJ-45 console port

Console output appears on devices connected to both ports, but console input is active on only one port at a time. By default, the USB connector takes precedence over the RJ-45 connector.



Note Windows PCs require a driver for the USB port. See the hardware installation guide for driver installation instructions.

Use the supplied USB Type A-to-USB mini-Type B cable to connect a PC or other device to the device. The connected device must include a terminal emulation application. When the device detects a valid USB connection to a powered-on device that supports host functionality (such as a PC), input from the RJ-45 console is immediately disabled, and input from the USB console is enabled. Removing the USB connection immediately reenables input from the RJ-45 console connection. An LED on the device shows which console connection is in use.

Console Port Change Logs

At software startup, a log shows whether the USB or the RJ-45 console is active. Every device always first displays the RJ-45 media type.

In the sample output, device 1 has a connected USB console cable. Because the bootloader did not change to the USB console, the first log from the device shows the RJ-45 console. A short time later, the console changes and the USB console log appears.

```
switch-1
*Mar  1 00:01:00.171: %USB_CONSOLE-6-MEDIA_RJ45: Console media-type is RJ45.
*Mar  1 00:01:00.431: %USB_CONSOLE-6-MEDIA_USB: Console media-type is USB.
```

When the USB cable is removed or the PC de-activates the USB connection, the hardware automatically changes to the RJ-45 console interface:

You can configure the console type to always be RJ-45, and you can configure an inactivity timeout for the USB connector.

USB 2.0 Host Port

The USB 2.0 host port provides access to external USB flash devices, also known as thumb drives or USB keys. The port supports Cisco USB flash drives with capacities from 128 MB to 16 GB (USB devices with port densities of 128 MB, 256 MB, 1 GB, 4 GB, 8 GB, and 16 GB are supported). You can use standard Cisco IOS command-line interface (CLI) commands to read, write, erase, and copy to or from the flash device. You can also configure the device to boot from the USB flash drive.

Disabling USB Ports

From Cisco IOS XE Bengaluru 17.5.x, all the USB ports in a standalone or stacked device can be disabled using the **platform usb disable** command. To reenble the USB ports, use the **no platform usb disable** command.

When a USB port is disabled, no system messages are generated if a USB is inserted.



Note The **platform usb disable** command does not disable Bluetooth dongles connected to USB ports.

This command works on a device configured with Cisco StackWise Virtual.

Interface Connections

Devices within a single VLAN can communicate directly through any switch. Ports in different VLANs cannot exchange data without going through a routing device. With a standard Layer 2 device, ports in different VLANs have to exchange information through a router. By using the device with routing enabled, when you configure both VLAN 20 and VLAN 30 with an SVI to which an IP address is assigned, packets can be sent from Host A to Host B directly through the device with no need for an external router.

Figure 1: Connecting VLANs with a Switch

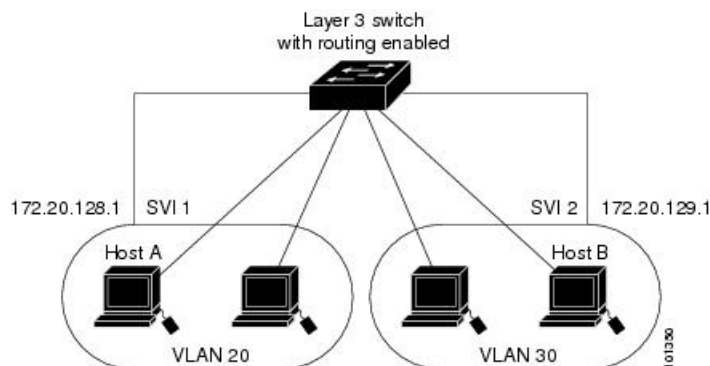

When the Network Advantage license is used on the device or the active device, the device uses the routing method to forward traffic between interfaces. If the Network Essentials license is used on the device or the active device, only basic routing (static routing and RIP) is supported. Whenever possible, to maintain high performance, forwarding is done by the device hardware. However, only IPv4 packets with Ethernet II encapsulation are routed in hardware.

The routing function can be enabled on all SVIs and routed ports. The device routes only IP traffic. When IP routing protocol parameters and address configuration are added to an SVI or routed port, any IP traffic received from these ports is routed.

Interface Configuration Mode

The device supports these interface types:

- Physical ports: Device ports and routed ports
- VLANs: Switch virtual interfaces

- Port channels: EtherChannel interfaces

You can also configure a range of interfaces.

To configure a physical interface (port), specify the interface type, module number, and device port number, and enter interface configuration mode.

- Type: FortyGigabitEthernet (fortygigabitethernet or fo) fiber ports.
- Switch number: The number that identifies the given device. The number range is assigned the first time the device initializes.
- Module number: The module or slot number on the device: switch (downlink) ports are 0, and uplink ports are 1.



Note Cisco Catalyst 9500 Series Switches - High Performance have their Module number as 0 always.

- Port number: The interface number on the device. The 10/100/1000 port numbers always begin at 1, starting with the far left port when facing the front of the device, for example, FortyGigabitEthernet1/0/1 or FortyGigabitEthernet1/0/8.

On a device with SFP uplink ports, the module number is 1 and the port numbers restart. For example, if the device has 24 10/100/1000 ports, the SFP module ports are GigabitEthernet1/1/1 through GigabitEthernet1/1/4 or TenGigabitEthernet1/1/1 through TenGigabitEthernet1/1/4.

You can identify physical interfaces by physically checking the interface location on the device. You can also use the **show** privileged EXEC commands to display information about a specific interface or all the interfaces on the switch. The remainder of this chapter primarily provides physical interface configuration procedures.

These are examples of how to configure interfaces on standalone device:

- To configure 40-G port 4 on a standalone device, enter this command:

```
Device# configure terminal
Device(config)# interface FortyGigabitEthernet1/0/4
```

Breakout Interfaces

C9500X-28C8D support breakout cables. These cables support 4x10 G by enabling a single 40-G QSFP+ interface to be split into four 10-G SFP+ interfaces and a single 100-G QSFP28 interface into four 25-G SFP28 interfaces. Starting with Cisco IOS XE Gibraltar 16.11.1, support for breakout cables is enabled for Cisco Catalyst 9500 Series Switches - High Performance with Cisco StackWise Virtual. Starting with Cisco IOS XE Cupertino 17.7.1, support for breakout cables is enabled for the C9500X-28C8D model of Cisco Catalyst 9500 Series Switches. Since its release with the Cisco IOS XE Dublin 17.10.1b, the 9500X-60L4D model of Cisco Catalyst 9500 Series Switches supports breakout cables.

Switch Models

Breakout cable support is available only on the following switch models and network modules, with a few limitations.

- C9500-12Q
- C9500-24Q
- C9500-40X-2Q
- C9500-16X-2Q
- C9500-32C
- C9500X-28C8D
- C9500X-60L4D

Network Modules

- C9500-NM-2Q

Limitations for Breakout Interfaces

Catalyst 9500 Series Switches

- To enable breakout for dual mode QSFP breakout cables, the **hw-module breakout module slot port port-range switch switch-num** command must be configured on all the ports of the switch. The range for the variables in the **hw-module breakout module slot port port-range switch switch-num** command are given below:
 - *slot* — Slot number of port depending on the chassis model.
 - *port-range* — Single port or range of ports on which breakout is configured. The range varies from 1 to 24.
 - *switch-num* — Switch number in the stack. The range varies from 1 to 8.

See [Breakout Interfaces](#) for the list of configurable interfaces.

- When Cisco StackWise Virtual is configured, breakout ports using 4X10G breakout cables can only be used as data ports; they cannot be used to configure StackWise Virtual links (SVLs) or dual-active detective (DAD) links.

Catalyst 9500 Series Switches - High Performance

- Breakout is supported only on 24 ports of the C9500-32C switch model. Every 4th port of C9500-32C does not support breakout due to ASIC limitation. Port numbers 4, 8, 12, 16, 20, 24, 28 and 32 — Hu1/0/4, Hu1/0/8, Hu1/0/12, Hu1/0/16, Hu1/0/20, Hu1/0/24, Hu1/0/28 and Hu1/0/32 — do not support breakout.
- Parent port is disabled after breakout is enabled on it but configuration on the parent port is saved.
- Breakout ports appear in the output of **show run**, **show interface status**, **show ip interface brief** and other show and configuration commands once breakout is enabled and they are automatically removed from all the show and configuration CLIs when breakout is disabled.
- When Cisco StackWise Virtual is configured, breakout ports using 4X25G and 4X10G breakout cables can only be used as data ports; they cannot be used to configure SVLs or DAD links.

- LED of the physical port on which breakout is enabled turns green if any one of the four breakout link is up but it turns off only when all the four breakout links are down.

See [Breakout Interfaces](#) for the list of configurable interfaces.

Catalyst 9500X Series Switches - C9500X-28C8D Switch Model

- To enable breakout for dual mode QSFP breakout cables on a standalone switch, the **hw-module breakout port number** or **hw-module breakout range** *port range* command must be configured on a port.

The range for the variables in these commands are listed below:

- **port number** — The port number to be converted into breakout ports. The range is 1- 36
 - *port range* — Single port or range of ports on which breakout is configured. The range varies from 1 to 36.
- Breakout is supported only on odd 100-G ports and on both odd and even 400-G ports.
- When you enable breakout on an odd 100-G port, the next even port becomes inactive. You should disable the even port if it is in a connected state. For example, if breakout has to enabled on port Hu1/0/5, you should ensure that Hu1/0/6 is in not connected state and is in disabled state.
- Parent port and the adjacent port (in case of 100-G ports) is disabled after breakout is enabled and the configuration on the parent port is deleted and not saved. The port returns to a default port status.
 - Breakout ports appear in the output of **show run**, **show interface status**, **show ip interface brief** and other show and configuration commands once breakout is enabled and they are automatically removed from all the show and configuration CLIs when breakout is disabled.

See [Breakout Interfaces](#) for the list of configurable interfaces.

Default Ethernet Interface Configuration

To configure Layer 2 parameters, if the interface is in Layer 3 mode, you must enter the **switchport** interface configuration command without any parameters to put the interface into Layer 2 mode. This shuts down the interface and then re-enables it, which might generate messages on the device to which the interface is connected. When you put an interface that is in Layer 3 mode into Layer 2 mode, the previous configuration information related to the affected interface might be lost, and the interface is returned to its default configuration.



Note Starting from Cisco IOS XE Gibraltar 16.11.1, the Cisco Catalyst 9500 Series Switches - High Performance bootup with interfaces in the default Layer 2 state. In all earlier releases, the default is Layer 3. (For all other models of the Cisco Catalyst 9500 Series Switches, the default interface continues to be Layer 2)

The default switchport mode for all Ethernet interfaces is **dynamic auto** for Cisco Catalyst 9500 Series Switches - High Performance and Cisco Catalyst 9500X Series Switches.

This table shows the Ethernet interface default configuration, including some features that apply only to Layer 2 interfaces.

Table 1: Default Layer 2 Ethernet Interface Configuration

Feature	Default Setting
Operating mode	Layer 2 or switching mode (switchport command) for C9500-12Q-E, C9500-12Q-A, C9500-24Q-E, C9500-24Q-A, C9500-40X-E, and C9500-40X-A models of the Cisco Catalyst 9500 Series Switches. Layer 3 or routed port for Cisco Catalyst 9500 Series Switches - High Performance and Cisco Catalyst 9500X Series Switches.
Allowed VLAN range	VLANs 1 to 4094.
Default VLAN (for access ports)	VLAN 1 (Layer 2 interfaces only).
Native VLAN (for IEEE 802.1Q trunks)	VLAN 1 (Layer 2 interfaces only).
VLAN trunking	Switchport mode dynamic auto (supports DTP) (Layer 2 interfaces only).
Port enable state	All ports are enabled.
Port description	None defined.
Speed	Autonegotiate. (Not supported on the 40-Gigabit interfaces.) Autonegotiation is supported on 25G, 40G, and 100G CU cables on the Cisco Catalyst 9500 Series Switches - High Performance. On Cisco Catalyst 9500X series switches, autonegotiation is enabled on 25G, 50G, 40G, 100G and 400G copper links, by default. Their speed is determined by the type of transceiver module plugged in.
Duplex mode	Autonegotiate. (Not supported on the 40-Gigabit interfaces.) Cisco Catalyst 9500 Series Switches - High Performance and Cisco Catalyst 9500X Series Switches support full duplex mode.
Flow control	Flow control is set to receive: on . It is always off for sent packets.
EtherChannel (PAgP)	Disabled on all Ethernet ports.
Port blocking (unknown multicast and unknown unicast traffic)	Disabled (not blocked) (Layer 2 interfaces only).
Broadcast, multicast, and unicast storm control	Disabled.
Protected port	Disabled (Layer 2 interfaces only).
Port security	Disabled (Layer 2 interfaces only).
Port Fast	Disabled.

Feature	Default Setting
Auto-MDIX	Enabled.

Interface Speed and Duplex Mode

The ethernet interfaces operate at full duplex mode. In full-duplex mode, two stations can send and receive traffic at the same time.

The following table lists the modules and the speed at which they operate.

Module	Speed with Transceiver Module Plugged in
C9500-32QC	40G, or 100G with a QSFP transceiver module, or 10G with CVR-QSFP-SFP10G transceiver module.
C9500-32C	40G, or 100G with a QSFP transceiver module, or 10G with CVR-QSFP-SFP10G transceiver module.
C9500-48Y4C	1G with SFP module, 10G with SFP+ module, 25G with QSFP28 module, 40G and 100G with QSFP module
C9500-24Y4C	1G with SFP module, 10G with SFP+ module, 25G with QSFP28 module, 40G and 100G with QSFP module.



Note SFP, SFP+ and SFP28 ports support speed (auto/10/100/100) and duplex (auto/full/half) options only if the 1000Base-T SFP or the GLC-GE-100FX modules are used.

Speed Limitation for C9500X-60L4D

- Each set of adjacent SFP ports such as ports 1 and 2, ports 4 and 5, ports 7 and 8, and so on, must be configured with the same speed. You can use the **show hw-module slot *slot_number* port-group speed** command to view port group speed. Port group limitation does not apply to all 400G and 50G ports on the bottom row (such as ports 3, 6, 9, 12, so on).
- If port-group speed is configured and mismatched optics are inserted, that port goes into the err-disabled state.
- If port-group speed is not configured and a transceiver module is inserted in the port-group, the behavior is in-deterministic.

Port Settings

The **port-settings** command can simultaneously or separately configure the speed, duplex, and auto negotiation for an interface, an interface range, or a port channel interface.

When using a single command to configure multiple parameters of the `port-settings` command, the order must be, **speed**, **duplex**, and **autoneg**. If you specify **speed** first, you can configure **duplex** and **autoneg** for the interface. If you specify **duplex** first, you can only configure **autoneg**. And, if you specify **autoneg** first, you cannot configure **speed** or **duplex**.

If the `port-settings` command is configured, this configuration is displayed only in the output of the `show running-config yang` command. The `show running-config` command output will not display information about this command.

For more information, see the section, *Configuring Port Settings for an Interface*.

Comparison of Commands

The `port-settings` command can be used instead of the `speed`, `duplex`, and `negotiation auto` commands available in the interface configuration mode.

The `port-settings`, `speed`, `duplex`, and `negotiation auto` commands coexist in the CLI.

Because the same parameters for an interface can be configured through two commands, the last configured values are used by the configuration.

This table provides a one-to-one comparison of the existing and newly-added commands:

Table 2: Command Comparison

Existing Command	Newly-Added <code>port-settings</code> Command
<code>speed 10</code>	<code>port-settings speed 10</code>
<code>speed 100</code>	<code>port-settings speed 100</code>
<code>speed auto</code>	<code>port-settings speed auto</code>
<code>speed auto 10 100</code>	<code>port-settings speed auto-list 10 100</code>
<code>speed nonegotiate</code>	<code>port-settings autoneg disable</code>
<code>duplex half</code>	<code>port-settings duplex half</code>
<code>duplex full</code>	<code>port-settings duplex full</code>
<code>negotiation auto</code>	<code>port-settings autoneg enable</code>
<code>no negotiation auto</code>	<code>port-settings autoneg disable</code>

IEEE 802.3x Flow Control

Flow control enables connected Ethernet ports to control traffic rates during congestion by allowing congested nodes to pause link operation at the other end. If one port experiences congestion and cannot receive any more traffic, it notifies the other port by sending a pause frame to stop sending until the condition clears. Upon receipt of a pause frame, the sending device stops sending any data packets, which prevents any loss of data packets during the congestion period.



Note The switch ports can receive, but not send, pause frames.

You use the **flowcontrol** interface configuration command to set the interface's ability to **receive** pause frames to **on**, **off**, or **desired**. The default state is **on**.

When set to **desired**, an interface can operate with an attached device that is required to send flow-control packets or with an attached device that is not required to but can send flow-control packets.

These rules apply to flow control settings on the device:

- **receive on (or desired)**: The port cannot send pause frames but can operate with an attached device that is required to or can send pause frames; the port can receive pause frames.
- **receive off**: Flow control does not operate in either direction. In case of congestion, no indication is given to the link partner, and no pause frames are sent or received by either device.



Note For details on the command settings and the resulting flow control resolution on local and remote ports, see the **flowcontrol** interface configuration command in the command reference for this release.

Layer 3 Interfaces

The device supports these types of Layer 3 interfaces:

- **SVIs**: You should configure SVIs for any VLANs for which you want to route traffic. SVIs are created when you enter a VLAN ID following the **interface vlan** global configuration command. To delete an SVI, use the **no interface vlan** global configuration command. You cannot delete interface VLAN 1.



-
- Note**
- When you create an SVI, it does not become active until it is associated with a physical port.
 - SVI MAC addresses do not change after a device reload. This is expected behavior.
-

When configuring SVIs, you can use the **switchport autostate exclude** command on a port to exclude that port from being included in determining SVI line-state. To disable autostate on the SVI, use the **no autostate** command on the SVI.

- **Routed ports**: Routed ports are physical ports configured to be in Layer 3 mode by using the **no switchport** interface configuration command. A routed port supports VLAN subinterfaces.

VLAN subinterface: A 802.1Q VLAN subinterface is a virtual Cisco IOS interface that is associated with a VLAN id on a routed physical interface. The parent interface is a physical port. Subinterfaces can be created only on Layer 3 physical interfaces. A subinterface can be associated with different functionalities such as IP addressing, forwarding policies, Quality of Service (QoS) policies, and security policies. Subinterfaces divide the parent interface into two or more virtual interfaces on which you can assign unique Layer 3 parameters such as IP addresses and dynamic routing protocols. The IP address for each subinterface should be in a different subnet from any other subinterface on the parent interface.

- **Layer 3 EtherChannel ports**: EtherChannel interfaces made up of routed ports.

A Layer 3 device can have an IP address assigned to each routed port and SVI.

There is no defined limit to the number of SVIs and routed ports that can be configured in a device or in a device stack. However, the interrelationship between the number of SVIs and routed ports and the number of other features being configured might have an impact on CPU usage because of hardware limitations. If the device is using its maximum hardware resources, attempts to create a routed port or SVI have these results:

- If you try to create a new routed port, the device generates a message that there are not enough resources to convert the interface to a routed port, and the interface remains as a switchport.
- If you try to create an extended-range VLAN, an error message is generated, and the extended-range VLAN is rejected.
- If the device is notified by VLAN Trunking Protocol (VTP) of a new VLAN, it sends a message that there are not enough hardware resources available and shuts down the VLAN. The output of the **show vlan** user EXEC command shows the VLAN in a suspended state.
- If the device attempts to boot up with a configuration that has more VLANs and routed ports than hardware can support, the VLANs are created, but the routed ports are shut down, and the device sends a message that this was due to insufficient hardware resources.



Note All Layer 3 interfaces require an IP address to route traffic. This procedure shows how to configure an interface as a Layer 3 interface and how to assign an IP address to an interface:

If the physical port is in Layer 2 mode (the default), you must enter the **no switchport** interface configuration command to put the interface into Layer 3 mode. Entering a **no switchport** command disables and then re-enables the interface, which might generate messages on the device to which the interface is connected. Furthermore, when you put an interface that is in Layer 2 mode into Layer 3 mode, the previous configuration information related to the affected interface might be lost, and the interface is returned to its default configuration.

How to Configure Interface Characteristics

The following sections provide information about the various tasks that comprise the procedure to configure interface characteristics.

Configuring an Interface

These general instructions apply to all interface configuration processes.

Procedure

	Command or Action	Purpose
Step 1	enable Example: Device> enable	Enables privileged EXEC mode. Enter your password, if prompted.
Step 2	configure terminal Example:	Enters global configuration mode.

	Command or Action	Purpose
	Device# <code>configure terminal</code>	
Step 3	interface Example: Device(config)# <code>interface fortygigabitethernet1/0/1</code> Device(config-if)#	Identifies the interface type, and the number of the connector. Note You do not need to add a space between the interface type and the interface number. For example, in the preceding line, you can specify either fortygigabitethernet 1/0/1 , or fortygigabitethernet1/0/1 .
Step 4	Follow each interface command with the interface configuration commands that the interface requires.	Defines the protocols and applications that will run on the interface. The commands are collected and applied to the interface when you enter another interface command or enter end to return to privileged EXEC mode.
Step 5	interface range or interface range macro	(Optional) Configures a range of interfaces. Note Interfaces configured in a range must be the same type and must be configured with the same feature options.
Step 6	show interfaces	Displays a list of all interfaces on or configured for the switch. A report is provided for each interface that the device supports or for the specified interface.

Adding a Description for an Interface

Follow these steps to add a description for an interface.

Procedure

	Command or Action	Purpose
Step 1	enable Example: Device> <code>enable</code>	Enables privileged EXEC mode. Enter your password, if prompted.
Step 2	configure terminal Example: Device# <code>configure terminal</code>	Enters global configuration mode.

	Command or Action	Purpose
Step 3	interface <i>interface-id</i> Example: Device(config)# interface fortygigabitethernet1/0/2	Specifies the interface for which you are adding a description, and enter interface configuration mode.
Step 4	description <i>string</i> Example: Device(config-if)# description Connects to Marketing	Adds a description for an interface.
Step 5	end Example: Device(config-if)# end	Returns to privileged EXEC mode.
Step 6	show interfaces <i>interface-id</i> description	Verifies your entry.
Step 7	copy running-config startup-config Example: Device# copy running-config startup-config	(Optional) Saves your entries in the configuration file.

Configuring a Range of Interfaces

To configure multiple interfaces with the same configuration parameters, use the **interface range** global configuration command. When you enter the interface-range configuration mode, all command parameters that you enter are attributed to all interfaces within that range until you exit this mode.

Procedure

	Command or Action	Purpose
Step 1	enable Example: Device> enable	Enables privileged EXEC mode. Enter your password, if prompted.
Step 2	configure terminal Example: Device# configure terminal	Enters global configuration mode.

	Command or Action	Purpose
Step 3	<p>interface range {<i>port-range</i> macro <i>macro_name</i>}</p> <p>Example:</p> <pre>Device(config)# interface range macro</pre>	<p>Specifies the range of interfaces (VLANs or physical ports) to be configured, and enter interface-range configuration mode.</p> <ul style="list-style-type: none"> You can use the interface range command to configure up to five port ranges or a previously defined macro. The macro variable is explained in Configuring and Using Interface Range Macros. In a comma-separated <i>port-range</i>, you must enter the interface type for each entry and enter spaces before and after the comma. In a hyphen-separated <i>port-range</i>, you do not need to re-enter the interface type, but you must enter a space before the hyphen. <p>Note Use the normal configuration commands to apply the configuration parameters to all interfaces in the range. Each command is executed as it is entered.</p>
Step 4	<p>end</p> <p>Example:</p> <pre>Device(config)# end</pre>	Returns to privileged EXEC mode.
Step 5	<p>show interfaces [<i>interface-id</i>]</p> <p>Example:</p> <pre>Device# show interfaces</pre>	Verifies the configuration of the interfaces in the range.
Step 6	<p>copy running-config startup-config</p> <p>Example:</p> <pre>Device# copy running-config startup-config</pre>	(Optional) Saves your entries in the configuration file.

Configuring and Using Interface Range Macros

You can create an interface range macro to automatically select a range of interfaces for configuration. Before you can use the **macro** keyword in the **interface range macro** global configuration command string, you must use the **define interface-range** global configuration command to define the macro.

Procedure

	Command or Action	Purpose
Step 1	enable Example: Device> enable	Enables privileged EXEC mode. Enter your password, if prompted.
Step 2	configure terminal Example: Device# configure terminal	Enters global configuration mode.
Step 3	define interface-range <i>macro_name</i> <i>interface-range</i> Example: Device(config)# define interface-range enet_list fortygigabitethernet1/0/1 - 5	Defines the interface-range macro, and saves it in NVRAM. <ul style="list-style-type: none"> • The <i>macro_name</i> is a 32-character maximum character string. • A macro can contain up to five comma-separated interface ranges. • Each <i>interface-range</i> must consist of the same port type. <p>Note Before you can use the macro keyword in the interface range macro global configuration command string, you must use the define interface-range global configuration command to define the macro.</p>
Step 4	interface range macro <i>macro_name</i> Example: Device(config)# interface range macro enet_list	Selects the interface range to be configured using the values saved in the interface-range macro called <i>macro_name</i> . You can now use the normal configuration commands to apply the configuration to all interfaces in the defined macro.
Step 5	end Example: Device(config)# end	Returns to privileged EXEC mode.
Step 6	show running-config include define Example: Device# show running-config include define	Shows the defined interface range macro configuration.

	Command or Action	Purpose
Step 7	copy running-config startup-config Example: <pre>Device# copy running-config startup-config</pre>	(Optional) Saves your entries in the configuration file.

Configuring Port Settings for an Interface

Use the **port-settings** command to simultaneously or separately configure the speed, duplex, and auto negotiation for an interface.

Procedure

	Command or Action	Purpose
Step 1	enable	Enables privileged EXEC mode. <ul style="list-style-type: none"> • Enter your password, if prompted.
Step 2	configure terminal	Enters global configuration mode.
Step 3	interface <i>interface-name interface-ID</i>	Configures an interface, and enters interface configuration mode.
Step 4	port-settings speed {10 100 1000 auto auto-list}	Enters the appropriate speed parameter for the interface.
Step 5	port-settings duplex {auto full half}	Configures duplex operation on an interface.
Step 6	port-settings autoneg {enable disable}	Configures duplex operation on an interface.
Step 7	port-settings speed 1000 duplex full autoneg enable	Configures port settings for an interface. <ul style="list-style-type: none"> • When configuring all port-setting parameters in a single command, the order must be speed, duplex, and autoneg.
Step 8	end	Exits interface configuration mode and returns to privileged EXEC mode.
Step 9	show running-config yang	Displays the YANG-specific configurations on the device. <ul style="list-style-type: none"> • The configured port-settings for the interface is displayed only in the output of the show running-config yang command.

Example

This example shows how to set the port settings for an interface.

```
Device# enable
Device# configure terminal
Device(config)# interface gigabitethernet 0/0
Device(config-if)# port-settings speed 1000
Device(config-if)# port-setting duplex full
Device(config-if)# port-setting autoneg enable
Device(config-if)# end
```

This example shows how to set all port setting parameters for an interface in a single command.

```
Device# enable
Device# configure terminal
Device(config)# interface gigabitethernet 0/0
Device(config-if)# port-settings speed 1000 duplex full autoneg enable
Device(config-if)# end
```

This sample output from the **show running-config yang** command, displays port settings configured for an interface.

```
Device# show running-config yang

Device# show running-config yang
Building configuration...
Current configuration : 19884 bytes
!!
Last configuration change at 23:53:04 UTC Tue Jun 11 2024 by platform
!
version 17.15
service timestamps debug datetime msec
service timestamps log datetime msec
!
hostname Device
!! vrf definition Mgmt-vrf
!
address-family ipv4
exit-address-family
!
address-family ipv6
exit-address-family
!
aaa new-model
!
aaa authentication login default local
aaa authorization exec default local
!
!
!
login on-success log
vtp domain GOV
vtp mode transparent
!!!!!!
stackwise-virtual
  domain 1
!
crypto pki trustpoint SLA-TrustPoint
  enrollment pkcs12
  revocation-check crl
```

```

    hash sha256
    !
    !
    interface Port-channel1
    no shutdown
    port-settings speed 1000 duplex full
    !
    interface GigabitEthernet0/0
    vrf forwarding Mgmt-vrf
    ip address 192.0.2.1 255.255.255.0
    no shutdown
    port-settings autoneg enable
    !
    interface GigabitEthernet1/1/0/1
    no shutdown
    !
    line vty 0 4
    exec-timeout 0 0
    transport input ssh
    line vty 5 15
    transport input ssh
    !
    netconf-yang
    end
    Device#

```

Configuring a Breakout Interface

For information about device compatibility, see the [Transceiver Module Group \(TMG\) Compatibility Matrix](#).

C9500-NM-2Q Network Module

The default port connections for the C9500-NM-2Q module depend on whether you use a 40G QSFP module or a 4x10G breakout cable.

- If you use a 40G QSFP module, the ports default to 40G interfaces.
- If you use a 4x10G breakout cable, one 40G port is split into four 10G ports.
- You can use a combination of 40G QSFP modules and 4x10G breakout cables.
- For a 40G port — **FortyGigabitEthernet 1/1/*port-num***, the corresponding starting port in every set of the four 10G breakout ports is **TenGigabitEthernet 1/1/4*xport-num-3***, where *port-num* is the port number. For example, the starting port in the first set of 10G breakout ports is TenGigabitEthernet1/1/1, the starting port in the second set of 10G starting breakout ports is TenGigabitEthernet1/1/5 and so on.

The following tables list all the interfaces which are configurable depending on the type of module and cable used. Note that the **show interface status** command displays all the interfaces in the active state.

- In [Table 3: C9500-NM-2Q Module with two 40G QSFP Modules](#), the 10G interfaces are displayed but are not active.
- In [Table 4: C9500-NM-2Q Module with two 4x10G Breakout Cables](#), the 40G interfaces are displayed but are not active.

Table 3: C9500-NM-2Q Module with two 40G QSFP Modules

Interface	Action
FortyGigabitEthernet1/1/1	Configure this interface
FortyGigabitEthernet1/1/2	Configure this interface
TenGigabitEthernet1/1/1	Disregard
TenGigabitEthernet1/1/2	Disregard
TenGigabitEthernet1/1/3	Disregard
TenGigabitEthernet1/1/4	Disregard
TenGigabitEthernet1/1/5	Disregard
TenGigabitEthernet1/1/6	Disregard
TenGigabitEthernet1/1/7	Disregard
TenGigabitEthernet1/1/8	Disregard

Table 4: C9500-NM-2Q Module with two 4x10G Breakout Cables

Interface	Action
FortyGigabitEthernet1/1/1	Disregard
FortyGigabitEthernet1/1/2	Disregard
TenGigabitEthernet1/1/1	Configure this interface
TenGigabitEthernet1/1/2	Configure this interface
TenGigabitEthernet1/1/3	Configure this interface
TenGigabitEthernet1/1/4	Configure this interface
TenGigabitEthernet1/1/5	Configure this interface
TenGigabitEthernet1/1/6	Configure this interface
TenGigabitEthernet1/1/7	Configure this interface
TenGigabitEthernet1/1/8	Configure this interface

C9500-12Q

The default port connections on the C9500-12Q switch model depends on whether you use a 40G QSFP module or a dual mode breakout cable.

- If you use a 40G QSFP module, the ports default to 40G interfaces.

- If you use a dual mode breakout cable, you can either configure a 40G port or four 10G ports by using the **hw-module breakout module** *module-num* **port** *port-num* **switch** *switch-num* command to switch between the 40G straight mode and 4x10G breakout mode, where *module-num* is 1, *port-num* varies from 1 to 12 and *switch-num* is the switch number in the stack which varies from 1 to 8.
- You can use a combination of 40G QSFP modules and 4x10G breakout cables.
- For a 40G port —**FortyGigabitEthernet 1/0/***port-num*, the corresponding starting port in every set of the four 10G breakout ports is **TenGigabitEthernet 1/0/4x***port-num-3*, where *port-num* is the port number. For example, the starting port in the first set of 10G breakout ports is TenGigabitEthernet1/0/1, the starting port in the second set of 10G starting breakout ports is TenGigabitEthernet1/0/5 and so on.

The following tables list all the interfaces which are configurable depending on the type of module and cable used. Note that the **show interface status** command displays all the interfaces in the active state.

- In [Table 5: C9500-12Q with only 40G QSFP Modules](#) in all the 12 ports, the 10G interfaces are displayed but are not active.
- In [Table 6: C9500-12Q with Breakout Cables](#) in all the ports, both the 10G and 40G interfaces are displayed. All the 10G interfaces from TenGigabitEthernet1/0/1 through TenGigabitEthernet1/0/48 are active and all the 40G interfaces from FortyGigabitEthernet1/0/1 through FortyGigabitEthernet1/0/12 are not active.

Table 5: C9500-12Q with only 40G QSFP Modules

Interface	Action
FortyGigabitEthernet1/0/1	Configure this interface
FortyGigabitEthernet1/0/2	Configure this interface
FortyGigabitEthernet1/0/3	Configure this interface
FortyGigabitEthernet1/0/4	Configure this interface
FortyGigabitEthernet1/0/5	Configure this interface
FortyGigabitEthernet1/0/6	Configure this interface
FortyGigabitEthernet1/0/7	Configure this interface
FortyGigabitEthernet1/0/8	Configure this interface
FortyGigabitEthernet1/0/9	Configure this interface
FortyGigabitEthernet1/0/10	Configure this interface
FortyGigabitEthernet1/0/11	Configure this interface
FortyGigabitEthernet1/0/12	Configure this interface
TenGigabitEthernet1/0/1	Disregard
TenGigabitEthernet1/0/2	Disregard
TenGigabitEthernet1/0/3	Disregard

Interface	Action
TenGigabitEthernet1/0/4	Disregard
TenGigabitEthernet1/0/5	Disregard
TenGigabitEthernet1/0/6	Disregard
TenGigabitEthernet1/0/7	Disregard
TenGigabitEthernet1/0/8	Disregard
TenGigabitEthernet1/0/9	Disregard
TenGigabitEthernet1/0/10	Disregard
TenGigabitEthernet1/0/11	Disregard
TenGigabitEthernet1/0/12	Disregard
TenGigabitEthernet1/0/13	Disregard
TenGigabitEthernet1/0/14	Disregard
TenGigabitEthernet1/0/15	Disregard
TenGigabitEthernet1/0/16	Disregard
TenGigabitEthernet1/0/17	Disregard
TenGigabitEthernet1/0/18	Disregard
TenGigabitEthernet1/0/19	Disregard
TenGigabitEthernet1/0/20	Disregard
TenGigabitEthernet1/0/21	Disregard
TenGigabitEthernet1/0/22	Disregard
TenGigabitEthernet1/0/23	Disregard
TenGigabitEthernet1/0/24	Disregard
TenGigabitEthernet1/0/25	Disregard
TenGigabitEthernet1/0/26	Disregard
TenGigabitEthernet1/0/27	Disregard
TenGigabitEthernet1/0/28	Disregard
TenGigabitEthernet1/0/29	Disregard
TenGigabitEthernet1/0/30	Disregard
TenGigabitEthernet1/0/31	Disregard

Interface	Action
TenGigabitEthernet1/0/32	Disregard
TenGigabitEthernet1/0/33	Disregard
TenGigabitEthernet1/0/34	Disregard
TenGigabitEthernet1/0/35	Disregard
TenGigabitEthernet1/0/36	Disregard
TenGigabitEthernet1/0/37	Disregard
TenGigabitEthernet1/0/38	Disregard
TenGigabitEthernet1/0/39	Disregard
TenGigabitEthernet1/0/40	Disregard
TenGigabitEthernet1/0/41	Disregard
TenGigabitEthernet1/0/42	Disregard
TenGigabitEthernet1/0/43	Disregard
TenGigabitEthernet1/0/44	Disregard
TenGigabitEthernet1/0/45	Disregard
TenGigabitEthernet1/0/46	Disregard
TenGigabitEthernet1/0/47	Disregard
TenGigabitEthernet1/0/48	Disregard

Table 6: C9500-12Q with Breakout Cables

Interface	Action
FortyGigabitEthernet1/0/1	Disregard
FortyGigabitEthernet1/0/2	Disregard
FortyGigabitEthernet1/0/3	Disregard
FortyGigabitEthernet1/0/4	Disregard
FortyGigabitEthernet1/0/5	Disregard
FortyGigabitEthernet1/0/6	Disregard
FortyGigabitEthernet1/0/7	Disregard
FortyGigabitEthernet1/0/8	Disregard

Interface	Action
FortyGigabitEthernet1/0/9	Disregard
FortyGigabitEthernet1/0/10	Disregard
FortyGigabitEthernet1/0/11	Disregard
FortyGigabitEthernet1/0/12	Disregard
TenGigabitEthernet1/0/1	Configure this interface, if 4x10G breakout is configured using the hw-module breakout module module-num port port-num switch switch-num command.
TenGigabitEthernet1/0/2	Configure this interface, if 4x10G breakout is configured using the hw-module breakout module module-num port port-num switch switch-num command.
TenGigabitEthernet1/0/3	Configure this interface, if 4x10G breakout is configured using the hw-module breakout module module-num port port-num switch switch-num command.
TenGigabitEthernet1/0/4	Configure this interface, if 4x10G breakout is configured using the hw-module breakout module module-num port port-num switch switch-num command.
TenGigabitEthernet1/0/5	Configure this interface, if 4x10G breakout is configured using the hw-module breakout module module-num port port-num switch switch-num command.
TenGigabitEthernet1/0/6	Configure this interface, if 4x10G breakout is configured using the hw-module breakout module module-num port port-num switch switch-num command.
TenGigabitEthernet1/0/7	Configure this interface, if 4x10G breakout is configured using the hw-module breakout module module-num port port-num switch switch-num command.
TenGigabitEthernet1/0/8	Configure this interface, if 4x10G breakout is configured using the hw-module breakout module module-num port port-num switch switch-num command.
TenGigabitEthernet1/0/9	Configure this interface, if 4x10G breakout is configured using the hw-module breakout module module-num port port-num switch switch-num command.

Interface	Action
TenGigabitEthernet1/0/10	Configure this interface, if 4x10G breakout is configured using the hw-module breakout module module-num port port-num switch switch-num command.
TenGigabitEthernet1/0/11	Configure this interface, if 4x10G breakout is configured using the hw-module breakout module module-num port port-num switch switch-num command.
TenGigabitEthernet1/0/12	Configure this interface, if 4x10G breakout is configured using the hw-module breakout module module-num port port-num switch switch-num command.
TenGigabitEthernet1/0/13	Configure this interface, if 4x10G breakout is configured using the hw-module breakout module module-num port port-num switch switch-num command.
TenGigabitEthernet1/0/14	Configure this interface, if 4x10G breakout is configured using the hw-module breakout module module-num port port-num switch switch-num command.
TenGigabitEthernet1/0/15	Configure this interface, if 4x10G breakout is configured using the hw-module breakout module module-num port port-num switch switch-num command.
TenGigabitEthernet1/0/16	Configure this interface, if 4x10G breakout is configured using the hw-module breakout module module-num port port-num switch switch-num command.
TenGigabitEthernet1/0/17	Configure this interface, if 4x10G breakout is configured using the hw-module breakout module module-num port port-num switch switch-num command.
TenGigabitEthernet1/0/18	Configure this interface, if 4x10G breakout is configured using the hw-module breakout module module-num port port-num switch switch-num command.
TenGigabitEthernet1/0/19	Configure this interface, if 4x10G breakout is configured using the hw-module breakout module module-num port port-num switch switch-num command.

Interface	Action
TenGigabitEthernet1/0/20	Configure this interface, if 4x10G breakout is configured using the hw-module breakout module module-num port port-num switch switch-num command.
TenGigabitEthernet1/0/21	Configure this interface, if 4x10G breakout is configured using the hw-module breakout module module-num port port-num switch switch-num command.
TenGigabitEthernet1/0/22	Configure this interface, if 4x10G breakout is configured using the hw-module breakout module module-num port port-num switch switch-num command.
TenGigabitEthernet1/0/23	Configure this interface, if 4x10G breakout is configured using the hw-module breakout module module-num port port-num switch switch-num command.
TenGigabitEthernet1/0/24	Configure this interface, if 4x10G breakout is configured using the hw-module breakout module module-num port port-num switch switch-num command.
TenGigabitEthernet1/0/25	Configure this interface, if 4x10G breakout is configured using the hw-module breakout module module-num port port-num switch switch-num command.
TenGigabitEthernet1/0/26	Configure this interface, if 4x10G breakout is configured using the hw-module breakout module module-num port port-num switch switch-num command.
TenGigabitEthernet1/0/27	Configure this interface, if 4x10G breakout is configured using the hw-module breakout module module-num port port-num switch switch-num command.
TenGigabitEthernet1/0/28	Configure this interface, if 4x10G breakout is configured using the hw-module breakout module module-num port port-num switch switch-num command.
TenGigabitEthernet1/0/29	Configure this interface, if 4x10G breakout is configured using the hw-module breakout module module-num port port-num switch switch-num command.

Interface	Action
TenGigabitEthernet1/0/30	Configure this interface, if 4x10G breakout is configured using the hw-module breakout module module-num port port-num switch switch-num command.
TenGigabitEthernet1/0/31	Configure this interface, if 4x10G breakout is configured using the hw-module breakout module module-num port port-num switch switch-num command.
TenGigabitEthernet1/0/32	Configure this interface, if 4x10G breakout is configured using the hw-module breakout module module-num port port-num switch switch-num command.
TenGigabitEthernet1/0/33	Configure this interface, if 4x10G breakout is configured using the hw-module breakout module module-num port port-num switch switch-num command.
TenGigabitEthernet1/0/34	Configure this interface, if 4x10G breakout is configured using the hw-module breakout module module-num port port-num switch switch-num command.
TenGigabitEthernet1/0/35	Configure this interface, if 4x10G breakout is configured using the hw-module breakout module module-num port port-num switch switch-num command.
TenGigabitEthernet1/0/36	Configure this interface, if 4x10G breakout is configured using the hw-module breakout module module-num port port-num switch switch-num command.
TenGigabitEthernet1/0/37	Configure this interface, if 4x10G breakout is configured using the hw-module breakout module module-num port port-num switch switch-num command.
TenGigabitEthernet1/0/38	Configure this interface, if 4x10G breakout is configured using the hw-module breakout module module-num port port-num switch switch-num command.
TenGigabitEthernet1/0/39	Configure this interface, if 4x10G breakout is configured using the hw-module breakout module module-num port port-num switch switch-num command.

Interface	Action
TenGigabitEthernet1/0/40	Configure this interface, if 4x10G breakout is configured using the hw-module breakout module module-num port port-num switch switch-num command.
TenGigabitEthernet1/0/41	Configure this interface, if 4x10G breakout is configured using the hw-module breakout module module-num port port-num switch switch-num command.
TenGigabitEthernet1/0/42	Configure this interface, if 4x10G breakout is configured using the hw-module breakout module module-num port port-num switch switch-num command.
TenGigabitEthernet1/0/43	Configure this interface, if 4x10G breakout is configured using the hw-module breakout module module-num port port-num switch switch-num command.
TenGigabitEthernet1/0/44	Configure this interface, if 4x10G breakout is configured using the hw-module breakout module module-num port port-num switch switch-num command.
TenGigabitEthernet1/0/45	Configure this interface, if 4x10G breakout is configured using the hw-module breakout module module-num port port-num switch switch-num command.
TenGigabitEthernet1/0/46	Configure this interface, if 4x10G breakout is configured using the hw-module breakout module module-num port port-num switch switch-num command.
TenGigabitEthernet1/0/47	Configure this interface, if 4x10G breakout is configured using the hw-module breakout module module-num port port-num switch switch-num command.
TenGigabitEthernet1/0/48	Configure this interface, if 4x10G breakout is configured using the hw-module breakout module module-num port port-num switch switch-num command.

C9500-24Q

The default port connections on the C9500-24Q switch model depends on whether you use a 40G QSFP module or a dual mode breakout cable.

- If you use a 40G QSFP module, the ports default to 40G interfaces.

- If you use a dual mode breakout cable, you can either configure a 40G port or four 10G ports by using the **hw-module breakout module** *module-num* **port** *port-num* **switch** *switch-num* command to switch between the 40G straight mode and 4x10G breakout mode, where *module-num* is 1, *port-num* varies from 1 to 24 and *switch-num* is the switch number in the stack which varies from 1 to 8.
- You can use a combination of 40G QSFP modules and 4x10G breakout cables.
- For a 40G port —**FortyGigabitEthernet 1/0/***port-num*, the corresponding starting port in every set of the four 10G breakout ports is **TenGigabitEthernet 1/0/4x***port-num-3*, where *port-num* is the port number. For example, the starting port in the first set of 10G breakout ports is TenGigabitEthernet1/0/1, the starting port in the second set of 10G starting breakout ports is TenGigabitEthernet1/0/5 and so on.

The following tables list all the interfaces which are configurable depending on the type of module and cable used. Note that the **show interface status** command displays all the interfaces in the active state.

- In [Table 7: C9500-24Q with only 40G QSFP Modules](#) in all the 24 ports, the 10G interfaces are displayed but are not active.
- In [Table 8: C9500-24Q with Breakout Cables](#), both the 10G and 40G interfaces are displayed but only 10G interfaces from TenGigabitEthernet1/0/1 through TenGigabitEthernet1/0/96 are active and only 40G interfaces from FortyGigabitEthernet1/0/1 through FortyGigabitEthernet1/0/24 are not active.

Table 7: C9500-24Q with only 40G QSFP Modules

Interface	Action
FortyGigabitEthernet1/0/1	Configure this interface
FortyGigabitEthernet1/0/2	Configure this interface
FortyGigabitEthernet1/0/3	Configure this interface
FortyGigabitEthernet1/0/4	Configure this interface
FortyGigabitEthernet1/0/5	Configure this interface
FortyGigabitEthernet1/0/6	Configure this interface
FortyGigabitEthernet1/0/7	Configure this interface
FortyGigabitEthernet1/0/8	Configure this interface
FortyGigabitEthernet1/0/9	Configure this interface
FortyGigabitEthernet1/0/10	Configure this interface
FortyGigabitEthernet1/0/11	Configure this interface
FortyGigabitEthernet1/0/12	Configure this interface
FortyGigabitEthernet1/0/13	Configure this interface
FortyGigabitEthernet1/0/14	Configure this interface
FortyGigabitEthernet1/0/15	Configure this interface

Interface	Action
FortyGigabitEthernet1/0/16	Configure this interface
FortyGigabitEthernet1/0/17	Configure this interface
FortyGigabitEthernet1/0/18	Configure this interface
FortyGigabitEthernet1/0/19	Configure this interface
FortyGigabitEthernet1/0/20	Configure this interface
FortyGigabitEthernet1/0/21	Configure this interface
FortyGigabitEthernet1/0/22	Configure this interface
FortyGigabitEthernet1/0/23	Configure this interface
FortyGigabitEthernet1/0/24	Configure this interface
TenGigabitEthernet1/0/1	Disregard
TenGigabitEthernet1/0/2	Disregard
TenGigabitEthernet1/0/3	Disregard
TenGigabitEthernet1/0/4	Disregard
TenGigabitEthernet1/0/5	Disregard
TenGigabitEthernet1/0/6	Disregard
TenGigabitEthernet1/0/7	Disregard
TenGigabitEthernet1/0/8	Disregard
TenGigabitEthernet1/0/9	Disregard
TenGigabitEthernet1/0/10	Disregard
TenGigabitEthernet1/0/11	Disregard
TenGigabitEthernet1/0/12	Disregard
TenGigabitEthernet1/0/13	Disregard
TenGigabitEthernet1/0/14	Disregard
TenGigabitEthernet1/0/15	Disregard
TenGigabitEthernet1/0/16	Disregard
TenGigabitEthernet1/0/17	Disregard
TenGigabitEthernet1/0/18	Disregard
TenGigabitEthernet1/0/19	Disregard

Interface	Action
TenGigabitEthernet1/0/20	Disregard
TenGigabitEthernet1/0/21	Disregard
TenGigabitEthernet1/0/22	Disregard
TenGigabitEthernet1/0/23	Disregard
TenGigabitEthernet1/0/24	Disregard
TenGigabitEthernet1/0/25	Disregard
TenGigabitEthernet1/0/26	Disregard
TenGigabitEthernet1/0/27	Disregard
TenGigabitEthernet1/0/28	Disregard
TenGigabitEthernet1/0/29	Disregard
TenGigabitEthernet1/0/30	Disregard
TenGigabitEthernet1//31	Disregard
TenGigabitEthernet1/0/32	Disregard
TenGigabitEthernet1/0/33	Disregard
TenGigabitEthernet1/0/34	Disregard
TenGigabitEthernet1/0/35	Disregard
TenGigabitEthernet1/0/36	Disregard
TenGigabitEthernet1/0/37	Disregard
TenGigabitEthernet1/0/38	Disregard
TenGigabitEthernet1/0/39	Disregard
TenGigabitEthernet1/0/40	Disregard
TenGigabitEthernet1/0/41	Disregard
TenGigabitEthernet1/0/42	Disregard
TenGigabitEthernet1/0/43	Disregard
TenGigabitEthernet1/0/44	Disregard
TenGigabitEthernet1/0/45	Disregard
TenGigabitEthernet1/0/46	Disregard
TenGigabitEthernet1/0/47	Disregard

Interface	Action
TenGigabitEthernet1/0/48	Disregard
TenGigabitEthernet1/0/49	Disregard
TenGigabitEthernet1/0/50	Disregard
TenGigabitEthernet1/0/51	Disregard
TenGigabitEthernet1/0/52	Disregard
TenGigabitEthernet1/0/53	Disregard
TenGigabitEthernet1/0/54	Disregard
TenGigabitEthernet1/0/55	Disregard
TenGigabitEthernet1/0/56	Disregard
TenGigabitEthernet1/0/57	Disregard
TenGigabitEthernet1/0/58	Disregard
TenGigabitEthernet1/0/59	Disregard
TenGigabitEthernet1/0/60	Disregard
TenGigabitEthernet1/0/61	Disregard
TenGigabitEthernet1/0/62	Disregard
TenGigabitEthernet1/0/63	Disregard
TenGigabitEthernet1/0/64	Disregard
TenGigabitEthernet1/0/65	Disregard
TenGigabitEthernet1/0/66	Disregard
TenGigabitEthernet1/0/67	Disregard
TenGigabitEthernet1/0/68	Disregard
TenGigabitEthernet1/0/69	Disregard
TenGigabitEthernet1/0/70	Disregard
TenGigabitEthernet1/0/71	Disregard
TenGigabitEthernet1/0/72	Disregard
TenGigabitEthernet1/0/73	Disregard
TenGigabitEthernet1/0/74	Disregard
TenGigabitEthernet1/0/75	Disregard

Interface	Action
TenGigabitEthernet1/0/76	Disregard
TenGigabitEthernet1/0/77	Disregard
TenGigabitEthernet1/0/78	Disregard
TenGigabitEthernet1/0/79	Disregard
TenGigabitEthernet1/0/80	Disregard
TenGigabitEthernet1/0/81	Disregard
TenGigabitEthernet1/0/82	Disregard
TenGigabitEthernet1/0/83	Disregard
TenGigabitEthernet1/0/84	Disregard
TenGigabitEthernet1/0/85	Disregard
TenGigabitEthernet1/0/86	Disregard
TenGigabitEthernet1/0/87	Disregard
TenGigabitEthernet1/0/88	Disregard
TenGigabitEthernet1/0/89	Disregard
TenGigabitEthernet1/0/90	Disregard
TenGigabitEthernet1/0/91	Disregard
TenGigabitEthernet1/0/92	Disregard
TenGigabitEthernet1/0/93	Disregard
TenGigabitEthernet1/0/94	Disregard
TenGigabitEthernet1/0/95	Disregard
TenGigabitEthernet1/0/96	Disregard

Table 8: C9500-24Q with Breakout Cables

Interface	Action
FortyGigabitEthernet1/0/1	Disregard
FortyGigabitEthernet1/0/2	Disregard
FortyGigabitEthernet1/0/3	Disregard
FortyGigabitEthernet1/0/4	Disregard

Interface	Action
FortyGigabitEthernet1/0/5	Disregard
FortyGigabitEthernet1/0/6	Disregard
FortyGigabitEthernet1/0/7	Disregard
FortyGigabitEthernet1/0/8	Disregard
FortyGigabitEthernet1/0/9	Disregard
FortyGigabitEthernet1/0/10	Disregard
FortyGigabitEthernet1/0/11	Disregard
FortyGigabitEthernet1/0/12	Disregard
FortyGigabitEthernet1/0/13	Disregard
FortyGigabitEthernet1/0/14	Disregard
FortyGigabitEthernet1/0/15	Disregard
FortyGigabitEthernet1/0/16	Disregard
FortyGigabitEthernet1/0/17	Disregard
FortyGigabitEthernet1/0/18	Disregard
FortyGigabitEthernet1/0/19	Disregard
FortyGigabitEthernet1/0/20	Disregard
FortyGigabitEthernet1/0/21	Disregard
FortyGigabitEthernet1/0/22	Disregard
FortyGigabitEthernet1/0/23	Disregard
FortyGigabitEthernet1/0/24	Disregard
TenGigabitEthernet1/0/1	Configure this interface, if 4x10G breakout is configured using the hw-module breakout module module-num port port-num switch switch-num command.
TenGigabitEthernet1/0/2	Configure this interface, if 4x10G breakout is configured using the hw-module breakout module module-num port port-num switch switch-num command.
TenGigabitEthernet1/0/3	Configure this interface, if 4x10G breakout is configured using the hw-module breakout module module-num port port-num switch switch-num command.

Interface	Action
TenGigabitEthernet1/0/4	Configure this interface, if 4x10G breakout is configured using the hw-module breakout module module-num port port-num switch switch-num command.
TenGigabitEthernet1/0/5	Configure this interface, if 4x10G breakout is configured using the hw-module breakout module module-num port port-num switch switch-num command.
TenGigabitEthernet1/0/6	Configure this interface, if 4x10G breakout is configured using the hw-module breakout module module-num port port-num switch switch-num command.
TenGigabitEthernet1/0/7	Configure this interface, if 4x10G breakout is configured using the hw-module breakout module module-num port port-num switch switch-num command.
TenGigabitEthernet1/0/8	Configure this interface, if 4x10G breakout is configured using the hw-module breakout module module-num port port-num switch switch-num command.
TenGigabitEthernet1/0/9	Configure this interface, if 4x10G breakout is configured using the hw-module breakout module module-num port port-num switch switch-num command.
TenGigabitEthernet1/0/10	Configure this interface, if 4x10G breakout is configured using the hw-module breakout module module-num port port-num switch switch-num command.
TenGigabitEthernet1/0/11	Configure this interface, if 4x10G breakout is configured using the hw-module breakout module module-num port port-num switch switch-num command.
TenGigabitEthernet1/0/12	Configure this interface, if 4x10G breakout is configured using the hw-module breakout module module-num port port-num switch switch-num command.
TenGigabitEthernet1/0/13	Configure this interface, if 4x10G breakout is configured using the hw-module breakout module module-num port port-num switch switch-num command.

Interface	Action
TenGigabitEthernet1/0/14	Configure this interface, if 4x10G breakout is configured using the hw-module breakout module module-num port port-num switch switch-num command.
TenGigabitEthernet1/0/15	Configure this interface, if 4x10G breakout is configured using the hw-module breakout module module-num port port-num switch switch-num command.
TenGigabitEthernet1/0/16	Configure this interface, if 4x10G breakout is configured using the hw-module breakout module module-num port port-num switch switch-num command.
TenGigabitEthernet1/0/17	Configure this interface, if 4x10G breakout is configured using the hw-module breakout module module-num port port-num switch switch-num command.
TenGigabitEthernet1/0/18	Configure this interface, if 4x10G breakout is configured using the hw-module breakout module module-num port port-num switch switch-num command.
TenGigabitEthernet1/0/19	Configure this interface, if 4x10G breakout is configured using the hw-module breakout module module-num port port-num switch switch-num command.
TenGigabitEthernet1/0/20	Configure this interface, if 4x10G breakout is configured using the hw-module breakout module module-num port port-num switch switch-num command.
TenGigabitEthernet1/0/21	Configure this interface, if 4x10G breakout is configured using the hw-module breakout module module-num port port-num switch switch-num command.
TenGigabitEthernet1/0/22	Configure this interface, if 4x10G breakout is configured using the hw-module breakout module module-num port port-num switch switch-num command.
TenGigabitEthernet1/0/23	Configure this interface, if 4x10G breakout is configured using the hw-module breakout module module-num port port-num switch switch-num command.

Interface	Action
TenGigabitEthernet1/0/24	Configure this interface, if 4x10G breakout is configured using the hw-module breakout module module-num port port-num switch switch-num command.
TenGigabitEthernet1/0/25	Configure this interface, if 4x10G breakout is configured using the hw-module breakout module module-num port port-num switch switch-num command.
TenGigabitEthernet1/0/26	Configure this interface, if 4x10G breakout is configured using the hw-module breakout module module-num port port-num switch switch-num command.
TenGigabitEthernet1/0/27	Configure this interface, if 4x10G breakout is configured using the hw-module breakout module module-num port port-num switch switch-num command.
TenGigabitEthernet1/0/28	Configure this interface, if 4x10G breakout is configured using the hw-module breakout module module-num port port-num switch switch-num command.
TenGigabitEthernet1/0/29	Configure this interface, if 4x10G breakout is configured using the hw-module breakout module module-num port port-num switch switch-num command.
TenGigabitEthernet1/0/30	Configure this interface, if 4x10G breakout is configured using the hw-module breakout module module-num port port-num switch switch-num command.
TenGigabitEthernet1/0/31	Configure this interface, if 4x10G breakout is configured using the hw-module breakout module module-num port port-num switch switch-num command.
TenGigabitEthernet1/0/32	Configure this interface, if 4x10G breakout is configured using the hw-module breakout module module-num port port-num switch switch-num command.
TenGigabitEthernet1/0/33	Configure this interface, if 4x10G breakout is configured using the hw-module breakout module module-num port port-num switch switch-num command.

Interface	Action
TenGigabitEthernet1/0/34	Configure this interface, if 4x10G breakout is configured using the hw-module breakout module module-num port port-num switch switch-num command.
TenGigabitEthernet1/0/35	Configure this interface, if 4x10G breakout is configured using the hw-module breakout module module-num port port-num switch switch-num command.
TenGigabitEthernet1/0/36	Configure this interface, if 4x10G breakout is configured using the hw-module breakout module module-num port port-num switch switch-num command.
TenGigabitEthernet1/0/37	Configure this interface, if 4x10G breakout is configured using the hw-module breakout module module-num port port-num switch switch-num command.
TenGigabitEthernet1/0/38	Configure this interface, if 4x10G breakout is configured using the hw-module breakout module module-num port port-num switch switch-num command.
TenGigabitEthernet1/0/39	Configure this interface, if 4x10G breakout is configured using the hw-module breakout module module-num port port-num switch switch-num command.
TenGigabitEthernet1/0/40	Configure this interface, if 4x10G breakout is configured using the hw-module breakout module module-num port port-num switch switch-num command.
TenGigabitEthernet1/0/41	Configure this interface, if 4x10G breakout is configured using the hw-module breakout module module-num port port-num switch switch-num command.
TenGigabitEthernet1/0/42	Configure this interface, if 4x10G breakout is configured using the hw-module breakout module module-num port port-num switch switch-num command.
TenGigabitEthernet1/0/43	Configure this interface, if 4x10G breakout is configured using the hw-module breakout module module-num port port-num switch switch-num command.

Interface	Action
TenGigabitEthernet1/0/44	Configure this interface, if 4x10G breakout is configured using the hw-module breakout module module-num port port-num switch switch-num command.
TenGigabitEthernet1/0/45	Configure this interface, if 4x10G breakout is configured using the hw-module breakout module module-num port port-num switch switch-num command.
TenGigabitEthernet1/0/46	Configure this interface, if 4x10G breakout is configured using the hw-module breakout module module-num port port-num switch switch-num command.
TenGigabitEthernet1/0/47	Configure this interface, if 4x10G breakout is configured using the hw-module breakout module module-num port port-num switch switch-num command.
TenGigabitEthernet1/0/48	Configure this interface, if 4x10G breakout is configured using the hw-module breakout module module-num port port-num switch switch-num command.
TenGigabitEthernet1/0/49	Configure this interface, if 4x10G breakout is configured using the hw-module breakout module module-num port port-num switch switch-num command.
TenGigabitEthernet1/0/50	Configure this interface, if 4x10G breakout is configured using the hw-module breakout module module-num port port-num switch switch-num command.
TenGigabitEthernet1/0/51	Configure this interface, if 4x10G breakout is configured using the hw-module breakout module module-num port port-num switch switch-num command.
TenGigabitEthernet1/0/52	Configure this interface, if 4x10G breakout is configured using the hw-module breakout module module-num port port-num switch switch-num command.
TenGigabitEthernet1/0/53	Configure this interface, if 4x10G breakout is configured using the hw-module breakout module module-num port port-num switch switch-num command.

Interface	Action
TenGigabitEthernet1/0/54	Configure this interface, if 4x10G breakout is configured using the hw-module breakout module module-num port port-num switch switch-num command.
TenGigabitEthernet1/0/55	Configure this interface, if 4x10G breakout is configured using the hw-module breakout module module-num port port-num switch switch-num command.
TenGigabitEthernet1/0/56	Configure this interface, if 4x10G breakout is configured using the hw-module breakout module module-num port port-num switch switch-num command.
TenGigabitEthernet1/0/57	Configure this interface, if 4x10G breakout is configured using the hw-module breakout module module-num port port-num switch switch-num command.
TenGigabitEthernet1/0/58	Configure this interface, if 4x10G breakout is configured using the hw-module breakout module module-num port port-num switch switch-num command.
TenGigabitEthernet1/0/59	Configure this interface, if 4x10G breakout is configured using the hw-module breakout module module-num port port-num switch switch-num command.
TenGigabitEthernet1/0/60	Configure this interface, if 4x10G breakout is configured using the hw-module breakout module module-num port port-num switch switch-num command.
TenGigabitEthernet1/0/61	Configure this interface, if 4x10G breakout is configured using the hw-module breakout module module-num port port-num switch switch-num command.
TenGigabitEthernet1/0/62	Configure this interface, if 4x10G breakout is configured using the hw-module breakout module module-num port port-num switch switch-num command.
TenGigabitEthernet1/0/63	Configure this interface, if 4x10G breakout is configured using the hw-module breakout module module-num port port-num switch switch-num command.

Interface	Action
TenGigabitEthernet1/0/64	Configure this interface, if 4x10G breakout is configured using the hw-module breakout module module-num port port-num switch switch-num command.
TenGigabitEthernet1/0/65	Configure this interface, if 4x10G breakout is configured using the hw-module breakout module module-num port port-num switch switch-num command.
TenGigabitEthernet1/0/66	Configure this interface, if 4x10G breakout is configured using the hw-module breakout module module-num port port-num switch switch-num command.
TenGigabitEthernet1/0/67	Configure this interface, if 4x10G breakout is configured using the hw-module breakout module module-num port port-num switch switch-num command.
TenGigabitEthernet1/0/68	Configure this interface, if 4x10G breakout is configured using the hw-module breakout module module-num port port-num switch switch-num command.
TenGigabitEthernet1/0/69	Configure this interface, if 4x10G breakout is configured using the hw-module breakout module module-num port port-num switch switch-num command.
TenGigabitEthernet1/0/70	Configure this interface, if 4x10G breakout is configured using the hw-module breakout module module-num port port-num switch switch-num command.
TenGigabitEthernet1/0/71	Configure this interface, if 4x10G breakout is configured using the hw-module breakout module module-num port port-num switch switch-num command.
TenGigabitEthernet1/0/72	Configure this interface, if 4x10G breakout is configured using the hw-module breakout module module-num port port-num switch switch-num command.
TenGigabitEthernet1/0/73	Configure this interface, if 4x10G breakout is configured using the hw-module breakout module module-num port port-num switch switch-num command.

Interface	Action
TenGigabitEthernet1/0/74	Configure this interface, if 4x10G breakout is configured using the hw-module breakout module module-num port port-num switch switch-num command.
TenGigabitEthernet1/0/75	Configure this interface, if 4x10G breakout is configured using the hw-module breakout module module-num port port-num switch switch-num command.
TenGigabitEthernet1/0/76	Configure this interface, if 4x10G breakout is configured using the hw-module breakout module module-num port port-num switch switch-num command.
TenGigabitEthernet1/0/77	Configure this interface, if 4x10G breakout is configured using the hw-module breakout module module-num port port-num switch switch-num command.
TenGigabitEthernet1/0/78	Configure this interface, if 4x10G breakout is configured using the hw-module breakout module module-num port port-num switch switch-num command.
TenGigabitEthernet1/0/79	Configure this interface, if 4x10G breakout is configured using the hw-module breakout module module-num port port-num switch switch-num command.
TenGigabitEthernet1/0/80	Configure this interface, if 4x10G breakout is configured using the hw-module breakout module module-num port port-num switch switch-num command.
TenGigabitEthernet1/0/81	Configure this interface, if 4x10G breakout is configured using the hw-module breakout module module-num port port-num switch switch-num command.
TenGigabitEthernet1/0/82	Configure this interface, if 4x10G breakout is configured using the hw-module breakout module module-num port port-num switch switch-num command.
TenGigabitEthernet1/0/83	Configure this interface, if 4x10G breakout is configured using the hw-module breakout module module-num port port-num switch switch-num command.

Interface	Action
TenGigabitEthernet1/0/84	Configure this interface, if 4x10G breakout is configured using the hw-module breakout module module-num port port-num switch switch-num command.
TenGigabitEthernet1/0/85	Configure this interface, if 4x10G breakout is configured using the hw-module breakout module module-num port port-num switch switch-num command.
TenGigabitEthernet1/0/86	Configure this interface, if 4x10G breakout is configured using the hw-module breakout module module-num port port-num switch switch-num command.
TenGigabitEthernet1/0/87	Configure this interface, if 4x10G breakout is configured using the hw-module breakout module module-num port port-num switch switch-num command.
TenGigabitEthernet1/0/88	Configure this interface, if 4x10G breakout is configured using the hw-module breakout module module-num port port-num switch switch-num command.
TenGigabitEthernet1/0/89	Configure this interface, if 4x10G breakout is configured using the hw-module breakout module module-num port port-num switch switch-num command.
TenGigabitEthernet1/0/90	Configure this interface, if 4x10G breakout is configured using the hw-module breakout module module-num port port-num switch switch-num command.
TenGigabitEthernet1/0/91	Configure this interface, if 4x10G breakout is configured using the hw-module breakout module module-num port port-num switch switch-num command.
TenGigabitEthernet1/0/92	Configure this interface, if 4x10G breakout is configured using the hw-module breakout module module-num port port-num switch switch-num command.
TenGigabitEthernet1/0/93	Configure this interface, if 4x10G breakout is configured using the hw-module breakout module module-num port port-num switch switch-num command.

Interface	Action
TenGigabitEthernet1/0/94	Configure this interface, if 4x10G breakout is configured using the hw-module breakout module module-num port port-num switch switch-num command.
TenGigabitEthernet1/0/95	Configure this interface, if 4x10G breakout is configured using the hw-module breakout module module-num port port-num switch switch-num command.
TenGigabitEthernet1/0/96	Configure this interface, if 4x10G breakout is configured using the hw-module breakout module module-num port port-num switch switch-num command.

C9500-32C

The default port connections on the C9500-32C switch model depends on whether you use a 40G QSFP module, a 100G QSFP28 module, a breakout cable or a dual mode breakout cable. You can use a combination of 40G QSFP modules, 100G QSFP28 modules and the 4x10G and 4x25G breakout cables. All the interfaces on C9500-32C switch model are named as HundredGigabitEthernet1/0/*port-num* irrespective of the module inserted into the ports — 40G QSFP module or 100G QSFP28 module.

If you use a dual mode breakout cable, you can either configure a 40G port or four 10G ports by using the **hw-module breakout module module-num port port-num switch switch-num** command to switch between the 40G straight mode and 4x10G breakout mode.

Enabling breakout on C9500-32C with Cisco StackWise Virtual

To enable breakout on a port, use the **hw-module switch switch-num breakout port port-number** command where *switch-num* varies between 1 and 2 and *port-number* varies from 1 and 32. Use the no form of this command to disable breakout on a port.

To enable breakout on all the supported breakout ports, use the **hw-module switch switch-num breakout port port-range** command where *switch-num* varies between 1 and 2 and *port-range* varies from 1 to 32. Use the no form of this command to disable breakout on all the supported ports.

Enabling breakout on C9500-32C without Cisco StackWise Virtual (Standalone Mode)

To enable breakout on a port, use the **hw-module breakout port port-number** command. Use the no form of this command to disable breakout on a port.

To enable breakout on all the supported breakout ports, use the **hw-module breakout port port-range** command where *port-range* is 1-32. Use the no form of this command to disable breakout on all the supported ports.

The following table lists all the interfaces which are configurable depending on the type of module or breakout cable used. Breakout of port 2 (40G) and port 7 (100G) is shown in the table below.

- A 4x10G breakout cable is inserted into port number 2. Breakout is enabled using the command **hw-module breakout 2**. Port number 2 — Hu1/0/2 — is split into four 10G ports — Hu1/0/2/1, Hu1/0/2/2, Hu1/0/2/3 and Hu1/0/2/4.

- A 4x25G breakout cable is inserted into port number 7. Breakout is enabled using the command **hw-module breakout 7**. Port number 7 — Hu1/0/7 — is split into four 25G ports — Hu1/0/7/1, Hu1/0/7/2, Hu1/0/7/3 and Hu1/0/7/4.

Table 9: C9500-32C with 40G QSFP modules, 100G QSFP28 modules and Breakout Cables

Interface	Action
HundredGigabitEthernet1/0/1	Configure this interface
HundredGigabitEthernet1/0/2	Disregard Note Although visible in the CLI, this port is inactive as 4x10G breakout is enabled on this port.
HundredGigabitEthernet1/0/3	Configure this interface
HundredGigabitEthernet1/0/4	Configure this interface
HundredGigabitEthernet1/0/5	Configure this interface
HundredGigabitEthernet1/0/6	Configure this interface
HundredGigabitEthernet1/0/7	Disregard Note Although visible in the CLI, this port is inactive as 4x25G breakout is enabled on this port.
HundredGigabitEthernet1/0/8	Configure this interface
HundredGigabitEthernet1/0/9	Configure this interface
HundredGigabitEthernet1/0/10	Configure this interface
HundredGigabitEthernet1/0/11	Configure this interface
HundredGigabitEthernet1/0/12	Configure this interface
HundredGigabitEthernet1/0/13	Configure this interface
HundredGigabitEthernet1/0/14	Configure this interface
HundredGigabitEthernet1/0/15	Configure this interface
HundredGigabitEthernet1/0/16	Configure this interface
HundredGigabitEthernet1/0/17	Configure this interface
HundredGigabitEthernet1/0/18	Configure this interface
HundredGigabitEthernet1/0/19	Configure this interface
HundredGigabitEthernet1/0/20	Configure this interface

Interface	Action
HundredGigabitEthernet1/0/21	Configure this interface
HundredGigabitEthernet1/0/22	Configure this interface
HundredGigabitEthernet1/0/23	Configure this interface
HundredGigabitEthernet1/0/24	Configure this interface
HundredGigabitEthernet1/0/23	Configure this interface
HundredGigabitEthernet1/0/24	Configure this interface
HundredGigabitEthernet1/0/25	Configure this interface
HundredGigabitEthernet1/0/26	Configure this interface
HundredGigabitEthernet1/0/27	Configure this interface
HundredGigabitEthernet1/0/28	Configure this interface
HundredGigabitEthernet1/0/29	Configure this interface
HundredGigabitEthernet1/0/30	Configure this interface
HundredGigabitEthernet1/0/31	Configure this interface
HundredGigabitEthernet1/0/32	Configure this interface
HundredGigabitEthernet1/0/2/1	Configure this interface
HundredGigabitEthernet1/0/2/2	Configure this interface
HundredGigabitEthernet1/0/2/3	Configure this interface
HundredGigabitEthernet1/0/2/4	Configure this interface
HundredGigabitEthernet1/0/7/1	Configure this interface
HundredGigabitEthernet1/0/7/2	Configure this interface
HundredGigabitEthernet1/0/7/3	Configure this interface
HundredGigabitEthernet1/0/7/4	Configure this interface

C9500X-28C8D

Enabling breakout on C9500X-28C8D without Cisco StackWise Virtual (Standalone Mode)

To enable breakout on a port, use the **hw-module breakout port** *port-number* command. Use the no form of this command to disable breakout on a port.

To enable breakout on all the supported breakout ports, use the **hw-module breakout port** *port-range* command where *port-range* is 1-36. Use the no form of this command to disable breakout on all the supported ports.

The following table lists all the interfaces which are configurable depending on the type of module or breakout cable used. Breakout of port 1 (40G) and port 7 (100G) is shown in the table below.

- A 4x10G breakout cable is inserted into port number 1. Breakout is enabled using the command **hw-module breakout 1**. Port number 1 — Hu1/0/1 — is split into four 10G ports — Hu1/0/1/1, Hu1/0/1/2, Hu1/0/1/3 and Hu1/0/1/4.
- A 4x25G breakout cable is inserted into port number 7. Breakout is enabled using the command **hw-module breakout 7**. Port number 7 — Hu1/0/7 — is split into four 25G ports — Hu1/0/7/1, Hu1/0/7/2, Hu1/0/7/3 and Hu1/0/7/4.
- A 4x100G breakout cable is inserted into port number 15. Breakout is enabled using the command **hw-module breakout 15**. Port number 15 — Fou1/0/15 — is split into four 100G ports — Fou1/0/15/1, Fou1/0/15/2, Fou1/0/15/3 and Fou1/0/15/4.
- A 2x100G breakout cable is inserted into port number 22. Breakout is enabled using the command **hw-module breakout 22**. Port number 22 — Fou1/0/22 — is split into two 100G ports — Fou1/0/22/1 and Fou1/0/22/2.

Table 10: 9500X-28C8D with 40G QSFP modules, 100G QSFP28 modules and Breakout Cables

Interface	Action
HundredGigabitEthernet1/0/1	Configure this interface Note Although visible in the CLI, this port is inactive as 4x10G breakout is enabled on this port.
HundredGigabitEthernet1/0/2	Disregard
HundredGigabitEthernet1/0/3	Configure this interface
HundredGigabitEthernet1/0/4	Disregard
HundredGigabitEthernet1/0/5	Configure this interface
HundredGigabitEthernet1/0/6	Disregard
HundredGigabitEthernet1/0/7	Configure this interface Note Although visible in the CLI, this port is inactive as 4x25G breakout is enabled on this port.
HundredGigabitEthernet1/0/8	Disregard
HundredGigabitEthernet1/0/9	Configure this interface
HundredGigabitEthernet1/0/10	Disregard
HundredGigabitEthernet1/0/11	Configure this interface
HundredGigabitEthernet1/0/12	Disregard

Interface	Action
HundredGigabitEthernet1/0/13	Configure this interface
HundredGigabitEthernet1/0/14	Disregard
FourHundredGigE1/0/15	Configure this interface
FourHundredGigE1/0/16	Configure this interface
FourHundredGigE1/0/17	Configure this interface
FourHundredGigE1/0/18	Configure this interface
FourHundredGigE1/0/19	Configure this interface
FourHundredGigE1/0/20	Configure this interface
FourHundredGigE1/0/21	Configure this interface
FourHundredGigE1/0/22	Configure this interface
HundredGigabitEthernet1/0/23	Configure this interface
HundredGigabitEthernet1/0/24	Disregard
HundredGigabitEthernet1/0/23	Configure this interface
HundredGigabitEthernet1/0/24	Disregard
HundredGigabitEthernet1/0/25	Configure this interface
HundredGigabitEthernet1/0/26	Disregard
HundredGigabitEthernet1/0/27	Configure this interface
HundredGigabitEthernet1/0/28	Disregard
HundredGigabitEthernet1/0/29	Configure this interface
HundredGigabitEthernet1/0/30	Disregard
HundredGigabitEthernet1/0/31	Configure this interface
HundredGigabitEthernet1/0/32	Disregard
HundredGigabitEthernet1/0/33	Configure this interface
HundredGigabitEthernet1/0/34	Disregard
HundredGigabitEthernet1/0/35	Configure this interface
HundredGigabitEthernet1/0/36	Disregard

C9500X-60L4D**Enabling breakout on C9500X-60L4D without Cisco StackWise Virtual (Standalone Mode)**

To enable breakout on a port, use the **hw-module breakout** *port-number* command. Use the no form of this command to disable breakout on a port.

To enable breakout on all the supported breakout ports, use the **hw-module breakout range** *port-range* command where *port-range* is 31-34. Use the no form of this command to disable breakout on all the supported ports.

The following table lists all the interfaces which are configurable depending on the type of module or breakout cable used. Breakout of port 31 (40G) and port 32 (100G) is shown in the table below.

- A 4x10G breakout cable is inserted into port number 31. Breakout is enabled using the command **hw-module breakout 31**. Port number 31—FourHundredGig1/0/31—is split into four 10G ports — FourHundredGig1/0/31/1, FourHundredGig1/0/31/2, FourHundredGig1/0/31/3, and FourHundredGig1/0/31/4.
- A 4x25G breakout cable is inserted into port number 32. Breakout is enabled using the command **hw-module breakout 32**. Port number 32 — FourHundredGig1/hw-module breakout 0/32—is split into four 25G ports — FourHundredGig1/0/32/1, FourHundredGig1/0/32/2, FourHundredGig1/0/32/3, and FourHundredGig1/0/32/4.
- A 2x100G breakout cable is inserted into port number 33. Breakout is enabled using the command **hw-module breakout 33**. Port number 33 — FourHundredGig1/0/33 — is split into two 100G ports — FourHundredGig1/0/33/1 and FourHundredGig1/0/33/2.
- A 4x100G breakout cable is inserted into port number 34. Breakout is enabled using the command **hw-module breakout 34**. Port number 34 — FourHundredGig1/0/34 — is split into four 100G ports — FourHundredGig1/0/34/1, FourHundredGig1/0/34/2, FourHundredGig1/0/34/3 and FourHundredGig1/0/34/4.

Table 11: 9500X-60L4D with 400G QSFP modules and Breakout Cables

Interface	Action
FourHundredGig1/0/31	Configure this interface
FourHundredGig1/0/32	Configure this interface
FourHundredGig1/0/33	Configure this interface
FourHundredGig1/0/34	Configure this interface

Configuring Forty Gigabit Ethernet Interface

Follow these steps to configure the forty gigabit ethernet interface. Use the no form of the command to disable the fortygigabit ethernet interface.

Procedure

	Command or Action	Purpose
Step 1	enable	Enables privileged EXEC mode.

	Command or Action	Purpose
	Example: Device> enable	<ul style="list-style-type: none"> • Enter your password if prompted.
Step 2	configure terminal Example: Device# configure terminal	Enters global configuration mode.
Step 3	interface <i>interface-id</i> Example: Device(config)# interface fortygigabitethernet1/0/9 Device(config-if)#	Specifies the interface type, that has to be configured.
Step 4	end Example: Device(config)# end	Returns to privileged EXEC mode.

Configuring Hundred Gigabit Ethernet Interface

Follow these steps to configure a hundred gigabit ethernet interface. Use the **no** form of the command to disable a hundred gigabit ethernet interface.

Procedure

	Command or Action	Purpose
Step 1	enable Example: Device> enable	Enables privileged EXEC mode. <ul style="list-style-type: none"> • Enter your password if prompted.
Step 2	configure terminal Example: Device# configure terminal	Enters global configuration mode.
Step 3	interface <i>interface-type interface-id</i> Example: Device(config)# interface HundredGigabitEthernet1/0/9	Specifies the interface that is to be configured.
Step 4	enable Example: Device(config-if)# enable	Enables the hundred gigabit ethernet interface. Use no enable command to disable the hundred gigabit ethernet interface.

Configuring Hundred GigabitEthernet Interfaces on C9500-32QC

C9500-32QC switch model support port speed of 40G and 100G depending on the QSFP module inserted into the port. The native port numbering and interface configuration on this model is explained below:

- C9500-32QC: The 40G ports on this switch can be configured to function as 100G ports using the CLI. To enable the 100 GigabitEthernet interfaces, you need to use the CLI.

Interfaces on C9500-32QC

Figure 2: Default Interfaces on C9500-32QC

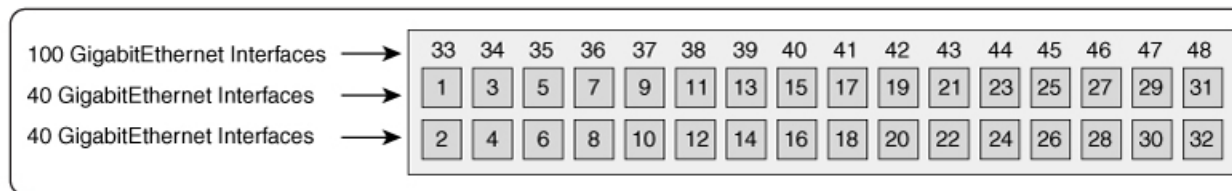

Insert the 100G QSFP28 module only in the odd-numbered ports (1 to 31) on the upper row. When you insert the 100G QSFP28 module, the corresponding odd-numbered 40G port from the upper row and the even-numbered 40G port from the lower row become inactive when you enter **enable** command on the CLI.



The default status of the 40 GigabitEthernet and 100 GigabitEthernet interfaces is as below:

- Port numbers 1 to 24 are active as 40 GigabitEthernet interfaces, by default. The corresponding 100 GigabitEthernet interfaces for these ports become inactive. To enable the 100 GigabitEthernet interfaces - 33 to 44, use the **enable** command on the 40 GigabitEthernet interface.
- Port numbers 25 to 32 are active as 100 GigabitEthernet interfaces, by default. The corresponding 40 GigabitEthernet interfaces for these ports become inactive. To enable the 40 GigabitEthernet interfaces on these ports - 25 to 32, use the **no enable** command on the 100 GigabitEthernet interface.

The port mapping for 100GigabitEthernet interfaces is shown in the table below:

Table 12: Port mapping for 100 GigabitEthernet interfaces

40 GigabitEthernet Ports/Interfaces	100 GigabitEthernet Interfaces
Port number 1 and 2 (FortyGigabitEthernet 1/0/1 and FortyGigabitEthernet 1/0/2)	HundredGigabitEthernet 1/0/33

40 GigabitEthernet Ports/Interfaces	100 GigabitEthernet Interfaces
Port number 3 and 4 (FortyGigabitEthernet 1/0/3 and FortyGigabitEthernet 1/0/4)	HundredGigabitEthernet 1/0/34
Port number 5 and 6 (FortyGigabitEthernet 1/0/5 and FortyGigabitEthernet 1/0/6)	HundredGigabitEthernet 1/0/35
Port number 7 and 8 (FortyGigabitEthernet 1/0/7 and FortyGigabitEthernet 1/0/8)	HundredGigabitEthernet 1/0/36
Port number 9 and 10 (FortyGigabitEthernet 1/0/9 and FortyGigabitEthernet 1/0/10)	HundredGigabitEthernet 1/0/37
Port number 11 and 12 (FortyGigabitEthernet 1/0/11 and FortyGigabitEthernet 1/0/12)	HundredGigabitEthernet 1/0/38
Port number 13 and 14 (FortyGigabitEthernet 1/0/13 and FortyGigabitEthernet 1/0/14)	HundredGigabitEthernet 1/0/39
Port number 15 and 16 (FortyGigabitEthernet 1/0/15 and FortyGigabitEthernet 1/0/16)	HundredGigabitEthernet 1/0/40
Port number 17 and 18 (FortyGigabitEthernet 1/0/17 and FortyGigabitEthernet 1/0/18)	HundredGigabitEthernet 1/0/41
Port number 19 and 20 (FortyGigabitEthernet 1/0/19 and FortyGigabitEthernet 1/0/20)	HundredGigabitEthernet 1/0/42
Port number 21 and 22 (FortyGigabitEthernet 1/0/21 and FortyGigabitEthernet 1/0/22)	HundredGigabitEthernet 1/0/43
Port number 23 and 24 (FortyGigabitEthernet 1/0/23 and FortyGigabitEthernet 1/0/24)	HundredGigabitEthernet 1/0/44

40 GigabitEthernet Ports/Interfaces	100 GigabitEthernet Interfaces
Port number 25 and 26 (FortyGigabitEthernet 1/0/25 and FortyGigabitEthernet 1/0/26)	HundredGigabitEthernet 1/0/45
Port number 27 and 28 (FortyGigabitEthernet 1/0/27 and FortyGigabitEthernet 1/0/28)	HundredGigabitEthernet 1/0/46
Port number 29 and 30 (FortyGigabitEthernet 1/0/29 and FortyGigabitEthernet 1/0/30)	HundredGigabitEthernet 1/0/47
Port number 31 and 32 (FortyGigabitEthernet 1/0/31 and FortyGigabitEthernet 1/0/32)	HundredGigabitEthernet 1/0/48

Configuring the IEEE 802.3x Flow Control

Follow these steps to configure the IEEE 802.3x flow control.

Procedure

	Command or Action	Purpose
Step 1	enable Example: Device> enable	Enables privileged EXEC mode. Enter your password, if prompted.
Step 2	configure terminal Example: Device# configure terminal	Enters global configuration mode
Step 3	interface <i>interface-id</i> Example: Device(config)# interface fortygigabitethernet1/0/1	Specifies the physical interface to be configured, and enters interface configuration mode.
Step 4	flowcontrol {receive} {on off desired} Example: Device(config-if)# flowcontrol receive on	Configures the flow control mode for the port.

	Command or Action	Purpose
Step 5	end Example: Device(config-if)# end	Returns to privileged EXEC mode.
Step 6	show flowcontrol interface <i>interface-id</i> Example: Device# show flowcontrol interface GigabitEthernet1/0/1	Verifies the specified interface flow control settings.
Step 7	show flowcontrol module <i>slot</i> Example: Device# show flowcontrol module 1	Verifies the interface flow control settings on the module.
Step 8	copy running-config startup-config Example: Device# copy running-config startup-config	(Optional) Saves your entries in the configuration file.

Configuring a Layer 3 Interface

Follow these steps to configure a layer 3 interface.

Procedure

	Command or Action	Purpose
Step 1	enable Example: Device> enable	Enables privileged EXEC mode. Enter your password, if prompted.
Step 2	configure terminal Example: Device# configure terminal	Enters global configuration mode.
Step 3	interface {fortygigabitethernet <i>interface-id</i> {vlan <i>vlan-id</i>} {port-channel <i>port-channel-number</i>} Example: Device(config)# interface fortygigabitethernet1/0/2	Specifies the interface to be configured as a Layer 3 interface, and enters interface configuration mode.

	Command or Action	Purpose
Step 4	no switchport Example: Device(config-if)# no switchport	(For physical ports only) Enters Layer 3 mode.
Step 5	ip address ip_address subnet_mask Example: Device(config-if)# ip address 192.20.135.21 255.255.255.0	Configures the IP address and IP subnet.
Step 6	no shutdown Example: Device(config-if)# no shutdown	Enables the interface.
Step 7	end Example: Device(config-if)# end	Returns to privileged EXEC mode.
Step 8	show interfaces [interface-id]	Verifies the configuration.
Step 9	copy running-config startup-config Example: Device# copy running-config startup-config	(Optional) Saves your entries in the configuration file.

Configuring a Logical Layer 3 GRE Tunnel Interface

Before you begin

Generic Routing Encapsulation (GRE) is a tunneling protocol used to encapsulate network layer protocols inside virtual point-to-point links. A GRE tunnel only provides encapsulation and not encryption.

**Note**

- GRE tunnels are supported on the hardware on Cisco Catalyst 9000 switches. When GRE is configured without tunnel options, packets are hardware-switched. When GRE is configured with tunnel options (such as key, checksum, and so on), packets are switched in the software. A maximum of 1000 GRE tunnels are supported.
- Other features such as Access Control Lists (ACL) and Quality of Service (QoS) are not supported for the GRE tunnels.
- The **tunnel path-mtu-discovery** command is not supported for GRE tunnels. To avoid fragmentation, you can set the maximum transmission unit (MTU) of both ends of the GRE tunnel to the lowest value by using the **ip mtu 256** command.

To configure a GRE tunnel, perform this task:

Procedure

	Command or Action	Purpose
Step 1	enable Example: Device> enable	Enables privileged EXEC mode. Enter your password, if prompted.
Step 2	configure terminal Example: Device# configure terminal	Enters global configuration mode.
Step 3	interface tunnel number Example: Device(config)# interface tunnel 2	Enables tunneling on the interface.
Step 4	ip address ip_address subnet_mask Example: Device(config)# ip address 100.1.1.1 255.255.255.0	Configures the IP address and IP subnet.
Step 5	tunnel source {ip_address type_number} Example: Device(config)# tunnel source 10.10.10.1	Configures the tunnel source.
Step 6	tunnel destination {host_name ip_address} Example: Device(config)# tunnel destination 10.10.10.2	Configures the tunnel destination.
Step 7	tunnel mode gre ip Example:	Configures the tunnel mode.

	Command or Action	Purpose
	Device(config)# tunnel mode gre ip	
Step 8	end Example: Device(config)# end	Exits configuration mode.

Configuring SVI Autostate Exclude

Follow these steps to exclude SVI autostate.

Procedure

	Command or Action	Purpose
Step 1	enable Example: Device> enable	Enables privileged EXEC mode. Enter your password, if prompted.
Step 2	configure terminal Example: Device# configure terminal	Enters global configuration mode.
Step 3	interface interface-id Example: Device(config)# interface fortygigabitethernet1/0/2	Specifies a Layer 2 interface (physical port or port channel), and enters interface configuration mode.
Step 4	switchport autostate exclude Example: Device(config-if)# switchport autostate exclude	Excludes the access or trunk port when defining the status of an SVI line state (up or down)
Step 5	end Example: Device(config-if)# end	Returns to privileged EXEC mode.
Step 6	show running config interface interface-id Example: Device# show running config interface fortygigabitethernet1/0/2	(Optional) Shows the running configuration. Verifies the configuration.

	Command or Action	Purpose
Step 7	copy running-config startup-config Example: Device# copy running-config startup-config	(Optional) Saves your entries in the configuration file.

Shutting Down and Restarting an Interface

Shutting down an interface disables all functions on the specified interface and marks the interface as unavailable on all monitoring command displays. This information is communicated to other network servers through all dynamic routing protocols. The interface is not mentioned in any routing updates.

Procedure

	Command or Action	Purpose
Step 1	enable Example: Device> enable	Enables privileged EXEC mode. Enter your password, if prompted.
Step 2	configure terminal Example: Device# configure terminal	Enters global configuration mode.
Step 3	interface {vlan vlan-id} {fortygigabitethernet interface-id} {port-channel port-channel-number} Example: Device(config)# interface fortygigabitethernet1/0/2	Selects the interface to be configured.
Step 4	shutdown Example: Device(config-if)# shutdown	Shuts down an interface.
Step 5	no shutdown Example: Device(config-if)# no shutdown	Restarts an interface.
Step 6	end Example:	Returns to privileged EXEC mode.

	Command or Action	Purpose
	<code>Device(config-if) # end</code>	
Step 7	show running-config Example: <code>Device# show running-config</code>	Verifies your entries.

Configuring the Console Media Type

Follow these steps to set the console media type to RJ-45. If you configure the console as RJ-45, USB console operation is disabled, and input comes only through the RJ-45 connector.

Procedure

	Command or Action	Purpose
Step 1	enable Example: <code>Device> enable</code>	Enables privileged EXEC mode. Enter your password, if prompted.
Step 2	configure terminal Example: <code>Device# configure terminal</code>	Enters global configuration mode.
Step 3	line console 0 Example: <code>Device(config)# line console 0</code>	Configures the console and enters line configuration mode.
Step 4	media-type rj45 switch <i>switch_number</i> Example: <code>Device(config-line)# media-type rj45 switch 1</code>	Configures the console media type to be only RJ-45 port. If you do not enter this command and both types are connected, the USB port is used by default.
Step 5	end Example: <code>Device(config)# end</code>	Returns to privileged EXEC mode.
Step 6	copy running-config startup-config Example: <code>Device# copy running-config startup-config</code>	(Optional) Saves your entries in the configuration file.

Configuring USB Inactivity Timeout

The configurable inactivity timeout reactivates the RJ-45 console port if the USB console port is activated but no input activity occurs on it for a specified time period. When the USB console port is deactivated due to a timeout, you can restore its operation by disconnecting and reconnecting the USB cable.

Procedure

	Command or Action	Purpose
Step 1	enable Example: Device> enable	Enables privileged EXEC mode. Enter your password, if prompted.
Step 2	configure terminal Example: Device# configure terminal	Enters global configuration mode.
Step 3	line console 0 Example: Device(config)# line console 0	Configures the console and enters line configuration mode.
Step 4	usb-inactivity-timeout switch <i>switch_number</i> <i>timeout-minutes</i> Example: Device(config-line)# usb-inactivity-timeout switch 1 30	Specifies an inactivity timeout for the console port. The range is 1 to 240 minutes. The default is to have no timeout configured.
Step 5	copy running-config startup-config Example: Device# copy running-config startup-config	(Optional) Saves your entries in the configuration file.

Disabling USB Ports

To disable all USB ports, perform this procedure.

Procedure

	Command or Action	Purpose
Step 1	enable Example:	Enables privileged EXEC mode. Enter your password, if prompted.

	Command or Action	Purpose
	Device> enable	
Step 2	configure terminal Example: Device# configure terminal	Enters global configuration mode.
Step 3	[no] platform usb disable Example: Device(config)# platform usb disable	Disables all the USB ports on the device. Use the no platform usb disable command to reenble the USB ports.
Step 4	exit Example: Device(config)# exit	Exits to privileged EXEC mode.
Step 5	copy running-config startup-config Example: Device# copy running-config startup-config	(Optional) Saves your entries in the configuration file.

Monitoring Interface Characteristics

The following sections provide information about monitoring interface characteristics.

Monitoring Interface Status

Commands entered at the privileged EXEC prompt display information about the interface, including the versions of the software and the hardware, the configuration, and statistics about the interfaces.

Table 13: show Commands for Interfaces

Command	Purpose
show interfaces <i>interface-id</i> status [err-disabled]	Displays interface status or a list of interfaces in the error-disabled state.
show interfaces [<i>interface-id</i>] switchport	Displays administrative and operational status of switching (nonrouting) ports. You can use this command to find out if a port is in routing or in switching mode.
show interfaces [<i>interface-id</i>] description	Displays the description configured on an interface or all interfaces and the interface status.
show ip interface [<i>interface-id</i>]	Displays the usability status of all interfaces configured for IP routing or the specified interface.

Command	Purpose
show interface [<i>interface-id</i>] stats	Displays the input and output packets by the switching path for the interface.
show interface [<i>interface-id</i>] link [module number]	Displays the up time and down time of an interface or all interfaces.
show interfaces <i>interface-id</i>	(Optional) Displays speed and duplex on the interface.
show interfaces transceiver dom-supported-list Note This command is not supported on the Cisco Catalyst 9500 Series Switches - High Performance.	(Optional) Displays Digital Optical Monitoring (DOM) status on the connect SFP modules.
show interfaces transceiver properties	(Optional) Displays temperature, voltage, or amount of current on the interface.
show interfaces [<i>interface-id</i>] [{ transceiver properties detail }] <i>module number</i>	Displays physical and operational status about an SFP module.
show running-config interface [<i>interface-id</i>]	Displays the running configuration in RAM for the interface.
show version	Displays the hardware configuration, software version, the names and sources of configuration files, and the boot images.
show controllers ethernet-controller <i>interface-id</i> phy	Displays the operational state of the auto-MDIX feature on the interface.

Clearing and Resetting Interfaces and Counters

Table 14: clear Commands for Interfaces

Command	Purpose
clear counters [<i>interface-id</i>]	Clears interface counters.
clear interface <i>interface-id</i>	Resets the hardware logic on an interface.
clear line [<i>number</i> console 0 vtty number]	Resets the hardware logic on an asynchronous serial line.



Note The **clear counters** privileged EXEC command does not clear counters retrieved by using Simple Network Management Protocol (SNMP), but only those seen with the **show interface** privileged EXEC command.

Configuration Examples for Interface Characteristics

The following sections provide examples of interface characteristics configurations.

Example: Adding a Description to an Interface

The following example shows how to add a description to an interface:

```
Device# configure terminal
Enter configuration commands, one per line. End with CNTRL/Z.
Device(config)# interface fortygigabitethernet1/0/2
Device(config-if)# description Connects to Marketing
Device(config-if)# end
Device# show interfaces fortygigabitethernet1/0/2 description

Interface Status      Protocol Description
Fol/0/1    down          down      Connects to Marketing
```

Example: Configuring a Range of Interfaces

The following example shows how to use the **interface range** global configuration command to shut down ports 1 to 2 on switch 1:

```
Device# configure terminal
Device(config)# interface range fortyGigabitEthernet 1/0/1-2
Device(config-if-range)# shut
```



Note If you enter multiple configuration commands while you are in interface-range mode, each command is executed as it is entered. The commands are not batched and executed after you exit interface-range mode. If you exit interface-range configuration mode while the commands are being executed, some commands might not be executed on all interfaces in the range. Wait until the command prompt reappears before exiting interface-range configuration mode.

Example: Configuring and Using Interface Range Macros

The following example shows how to define an interface-range named *enet_list* to include ports 1 and 2 on switch 1 and to verify the macro configuration:

```
Device# configure terminal
Device(config)# define interface-range enet_list fortyGigabitEthernet 1/0/1 - 2
Device(config)# end
Device# show running-config | include define
define interface-range enet_list FortyGigabitEthernet1/0/1
```

The following example shows how to enter interface-range configuration mode for the interface-range macro *enet_list*:

```
Device# configure terminal
```

```
Device(config)# interface range macro enet_list
Device(config-if-range)#
```

The following example shows how to delete the interface-range macro *enet_list* and to verify that it was deleted:

```
Device# configure terminal
Device(config)# no define interface-range enet_list
Device(config)# end
Device# show run | include define
Device#
```

Example: Configuring a Layer 3 Interface

The following example shows how to configure a Layer 3 interface:

```
Device# configure terminal
Enter configuration commands, one per line. End with CNTL/Z.
Device(config)# interface fortygigabitethernet1/0/2
Device(config-if)# no switchport
Device(config-if)# ip address 192.20.135.21 255.255.255.0
Device(config-if)# no shutdown
```

Example: Configuring 40G and 100G on C9500-32QC

The following example shows how to enable interface HundredGigabitEthernet 1/0/40. When you enable the interface HundredGigabitEthernet 1/0/40, the corresponding FortyGigabitEthernet 1/0/15 and FortyGigabitEthernet 1/0/16 interfaces, become inactive.

```
Device# configure terminal
Device(config)interface HundredGigabitEthernet 1/0/40
Device(config-if)enable
Device(config-if)end
```

The following example shows how to enable interface FortyGigabitEthernet 1/0/25. When you disable the interface HundredGigabitEthernet 1/0/45, the corresponding FortyGigabitEthernet 1/0/25 and FortyGigabitEthernet 1/0/26 interfaces, become active.

```
Device# configure terminal
Device(config)interface HundredGigabitEthernet 1/0/45
Device(config-if)no enable
Device(config-if)end
```

The following is sample output of all the 40 GigabitEthernet and 100 GigabitEthernet interfaces on C9500-32QC.

```
Device# show interface status
```

Port	Name	Status	Vlan	Duplex	Speed	Type
Fo1/0/1	40G AOC10M	notconnect	routed	full	40G	QSFP
Fo1/0/2	40G CU3M	notconnect	routed	full	40G	QSFP
Fo1/0/3	100G CU3M	notconnect	routed	full	100G	QSFP
Fo1/0/4		notconnect	routed	full	40G	QSFP

```

40G CU5M
Fo1/0/5          notconnect  routed      full  100G QSFP
100G CU3M
Fo1/0/6          notconnect  routed      full  40G QSFP
40G AOC2M
Fo1/0/7          notconnect  routed      full  100G QSFP
100G CU3M
Fo1/0/8          notconnect  routed      full  40G QSFP
40G CR4 SFP
Fo1/0/9          notconnect  routed      full  100G QSFP
100G CU3M
Fo1/0/10         notconnect  routed      auto  auto unknown
Fo1/0/11         notconnect  routed      full  100G QSFP
100G CU3M
Fo1/0/12         notconnect  routed      auto  auto unknown
Fo1/0/13         notconnect  routed      full  100G QSFP
100G CU3M
    
```

```

Port      Name      Status      Vlan      Duplex  Speed Type
Fo1/0/14  notconnect  routed      auto  auto unknown
Fo1/0/15  notconnect  routed      full  100G QSFP
100G CU3M
Fo1/0/16  notconnect  routed      auto  auto unknown
Fo1/0/17  notconnect  routed      full  40G QSFP
40G AOC10M
Fo1/0/18  notconnect  routed      auto  auto unknown
Fo1/0/19  notconnect  routed      full  40G QSFP
40G AOC3M
Fo1/0/20  notconnect  routed      auto  auto unknown
Fo1/0/21  notconnect  routed      auto  auto unknown
Fo1/0/22  notconnect  routed      full  40G QSFP
40G CR4 SFP
Fo1/0/23  notconnect  routed      full  40G QSFP
40G CR4 SFP
Fo1/0/24  notconnect  routed      full  40G QSFP
40G CR4 SFP
Fo1/0/25  inactive    routed      auto  auto unknown
Fo1/0/26  inactive    routed      auto  auto unknown
Fo1/0/27  inactive    routed      auto  auto unknown
Fo1/0/28  inactive    routed      full  40G QSFP
40G CR4 SFP
Fo1/0/29  inactive    routed      auto  auto unknown
    
```

```

Port      Name      Status      Vlan      Duplex  Speed Type
Fo1/0/30  inactive    routed      auto  auto unknown
Fo1/0/31  inactive    routed      auto  auto unknown
Fo1/0/32  inactive    routed      full  40G QSFP
40G CR4 SFP
Hu1/0/33  inactive    routed      auto  auto unknown
Hu1/0/34  inactive    routed      auto  auto unknown
Hu1/0/35  inactive    routed      auto  auto unknown
    
```

```

Hu1/0/36                inactive    routed      auto    auto unknown
Hu1/0/37                inactive    routed      auto    auto unknown
Hu1/0/38                inactive    routed      auto    auto unknown
Hu1/0/39                inactive    routed      auto    auto unknown
Hu1/0/40                inactive    routed      auto    auto unknown
Hu1/0/41                inactive    routed      auto    auto unknown
Hu1/0/42                inactive    routed      auto    auto unknown
Hu1/0/43                inactive    routed      auto    auto unknown
Hu1/0/44                inactive    routed      auto    auto unknown
Hu1/0/45                notconnect routed      full    40G QSFP
40G CU3M
Hu1/0/46                connected  routed      full    100G QSFP
100G CU3M
Hu1/0/47                connected  routed      full    100G QSFP
100G CU3M
Hu1/0/48                connected  routed      full    100G QSFP
100G CU3M

```

Example: Configuring a Breakout Interface

Catalyst 9500 Series Switches

The following example shows a sample output of the **show interface status** command with dual mode 40G QSFP module inserted into port number 2 of the C9500-24Q switch model:

```
Device# show interface status
```

```

Port      Name           Status      Vlan      Duplex  Speed Type
Fo2/0/1   Name           notconnect  1         auto    auto unknown
Fo2/0/2   Name           notconnect  1         full    40G QSFP 40G SR4 SFP
Fo2/0/3   Name           notconnect  1         auto    auto unknown
Fo2/0/4   Name           notconnect  1         auto    auto unknown
Fo2/0/5   Name           notconnect  1         auto    auto unknown
Fo2/0/6   Name           notconnect  1         auto    auto unknown
Fo2/0/7   Name           notconnect  1         auto    auto unknown
Fo2/0/8   Name           notconnect  1         auto    auto unknown
Fo2/0/9   Name           notconnect  1         auto    auto unknown
Fo2/0/10  Name           notconnect  1         auto    auto unknown
Fo2/0/11  Name           notconnect  1         auto    auto unknown
Fo2/0/12  Name           notconnect  1         auto    auto unknown
Fo2/0/13  Name           notconnect  1         auto    auto unknown
Fo2/0/14  Name           notconnect  1         auto    auto unknown
Fo2/0/15  Name           notconnect  1         auto    auto unknown
Fo2/0/16  Name           notconnect  1         auto    auto unknown
Fo2/0/17  Name           notconnect  1         auto    auto unknown
Fo2/0/18  Name           notconnect  1         auto    auto unknown
Fo2/0/19  Name           notconnect  1         auto    auto unknown
Fo2/0/20  Name           notconnect  1         auto    auto unknown
Fo2/0/21  Name           notconnect  1         auto    auto unknown
Fo2/0/22  Name           notconnect  1         auto    auto unknown
Fo2/0/23  Name           notconnect  1         auto    auto unknown
Fo2/0/24  Name           notconnect  1         auto    auto unknown

```

```

.....
.....
.....
.....(Output truncated).....

```

The following example shows a sample output of the **show interface status** command when 40G QSFP module inserted in port number 2 is removed and 4x10G breakout cable is inserted into port number 2 after using the command **hw-mod breakout module 1 port 2 switch 2**. Port number 2 — Fo2/0/2 — is split into four 10G ports — Te2/0/5, Te2/0/6, Te2/0/7 and Te2/0/8.

```
Device# configure terminal
Device(config)# hw-mod breakout module 1 port 2 switch 2
Device(config)#

*May 17 21:35:26.003 UTC: %PLATFORM_PM-6-MODULE_REMOVED: SFP module with interface name
Fo2/0/2 removed
*May 17 21:35:27.399 UTC: %PLATFORM_PM-6-FRULINK_REMOVED: 1x40G Port2 uplink module removed
from switch 2 slot 1
*May 17 21:35:27.899 UTC: %PLATFORM_PM-6-FRULINK_INSERTED: BC:4x10G Port2 uplink module
inserted in the switch 2 slot 1
*May 17 21:35:29.399 UTC: %LINK-3-UPDOWN: Interface FortyGigabitEthernet2/0/2, changed state
to down
*May 17 21:35:31.181 UTC: %PLATFORM_PM-6-MODULE_INSERTED: SFP module inserted with interface
name Te2/0/5
*May 17 21:35:33.414 UTC: %PLATFORM_PM-6-MODULE_INSERTED: SFP module inserted with interface
name Te2/0/6
*May 17 21:35:35.648 UTC: %PLATFORM_PM-6-MODULE_INSERTED: SFP module inserted with interface
name Te2/0/7
*May 17 21:35:37.881 UTC: %PLATFORM_PM-6-MODULE_INSERTED: SFP module inserted with interface
name Te2/0/8
*May 17 21:35:42.234 UTC: %LINK-3-UPDOWN: Interface TenGigabitEthernet2/0/5, changed state
to up
*May 17 21:35:43.234 UTC: %LINEPROTO-5-UPDOWN: Line protocol on Interface
TenGigabitEthernet2/0/5, changed state to up
*May 17 21:35:51.460 UTC: %LINK-3-UPDOWN: Interface TenGigabitEthernet2/0/6, changed state
to up
*May 17 21:35:51.506 UTC: %LINK-3-UPDOWN: Interface TenGigabitEthernet2/0/7, changed state
to up
*May 17 21:35:51.551 UTC: %LINK-3-UPDOWN: Interface TenGigabitEthernet2/0/8, changed state
to up
*May 17 21:35:52.286 UTC: %LINEPROTO-5-UPDOWN: Line protocol on Interface Vlan1, changed
state to up
*May 17 21:35:52.461 UTC: %LINEPROTO-5-UPDOWN: Line protocol on Interface
TenGigabitEthernet2/0/6, changed state to up
*May 17 21:35:52.505 UTC: %LINEPROTO-5-UPDOWN: Line protocol on Interface
TenGigabitEthernet2/0/7, changed state to up
*May 17 21:35:52.551 UTC: %LINEPROTO-5-UPDOWN: Line protocol on Interface
TenGigabitEthernet2/0/8, changed state to up
Device(config)# end
```

```
Device# show interface status
```

Port	Name	Status	Vlan	Duplex	Speed	Type
Fo2/0/1		notconnect	1	auto	auto	unknown
Fo2/0/3		notconnect	1	auto	auto	unknown
Fo2/0/4		notconnect	1	auto	auto	unknown
Fo2/0/5		notconnect	1	auto	auto	unknown
Fo2/0/6		notconnect	1	auto	auto	unknown
Fo2/0/7		notconnect	1	auto	auto	unknown
Fo2/0/8		notconnect	1	auto	auto	unknown
Fo2/0/9		notconnect	1	auto	auto	unknown
Fo2/0/10		notconnect	1	auto	auto	unknown
Fo2/0/11		notconnect	1	auto	auto	unknown
Fo2/0/12		notconnect	1	auto	auto	unknown
Fo2/0/13		notconnect	1	auto	auto	unknown
Fo2/0/14		notconnect	1	auto	auto	unknown
Fo2/0/15		notconnect	1	auto	auto	unknown
Fo2/0/16		notconnect	1	auto	auto	unknown

Example: Configuring a Breakout Interface

```

Fo2/0/17          notconnect 1          auto   auto unknown
Fo2/0/18          notconnect 1          auto   auto unknown
Fo2/0/19          notconnect 1          auto   auto unknown
Fo2/0/20          notconnect 1          auto   auto unknown
Fo2/0/21          notconnect 1          auto   auto unknown
Fo2/0/22          notconnect 1          auto   auto unknown
Fo2/0/23          notconnect 1          auto   auto unknown
Fo2/0/24          notconnect 1          auto   auto unknown
.....
.....
..... (Output truncated) .....
Te2/0/5           connected 1          full   10G
Te2/0/6           connected 1          full   10G
Te2/0/7           connected 1          full   10G QSFP 40G SR4 SFP
Te2/0/8           connected 1          full   10G
.....
.....
..... (Output truncated) .....

```

Catalyst 9500 Series Switches - High Performance

The following example shows a sample output of the **show interface status** command after enabling breakout on port 1 with 4x10G breakout cable inserted on port 7 with 4x25G breakout cable inserted using the **hw-module breakout port-num** command of the C9500-32C switch model:

- Port number 1 — Hu1/0/1 — is split into four 10G ports — Hu1/0/1/1, Hu1/0/1/2, Hu1/0/1/3 and Hu1/0/1/4.
- Port number 7 — Hu1/0/7 — is split into four 25G ports — Hu1/0/7/1, Hu1/0/7/2, Hu1/0/7/3 and Hu1/0/7/4.

Device# **show interface status**

Port	Name	Status	Vlan	Duplex	Speed	Type
Hu1/0/1		inactive	1	full	40G	unknown
Hu1/0/2		notconnect	1	full	40G	unknown
Hu1/0/3		notconnect	1	full	40G	unknown
Hu1/0/4		notconnect	1	auto	auto	unknown
Hu1/0/5		notconnect	1	full	40G	unknown
Hu1/0/6		notconnect	1	full	40G	unknown
Hu1/0/7		inactive	1	full	100G	unknown
Hu1/0/8		connected	111	full	100G	QSFP 100G CU1M
Hu1/0/9		notconnect	1	full	40G	unknown
Hu1/0/10		notconnect	1	full	40G	unknown
Hu1/0/11		notconnect	1	full	40G	unknown
Hu1/0/12		notconnect	1	auto	auto	unknown
Hu1/0/13		notconnect	1	full	100G	unknown
Hu1/0/14		notconnect	1	full	40G	unknown
Hu1/0/15		notconnect	1	full	40G	unknown
Hu1/0/16		notconnect	1	auto	auto	unknown
Hu1/0/17		notconnect	1	full	100G	unknown
Hu1/0/18		notconnect	1	full	40G	unknown
Hu1/0/19		notconnect	1	full	40G	QSFP 4SFP10G
CU5M						
Hu1/0/20		connected	48	full	100G	QSFP 100G AOC10M
Hu1/0/21		notconnect	1	full	40G	unknown
Hu1/0/22		notconnect	1	full	40G	unknown
Hu1/0/23		notconnect	1	full	40G	unknown
Hu1/0/24		notconnect	1	auto	auto	unknown
Hu1/0/25		notconnect	1	full	40G	unknown
Hu1/0/26		notconnect	1	full	40G	unknown
Hu1/0/27		notconnect	1	full	40G	QSFP 4SFP10G

```

CU4M
Hu1/0/28                connected      112          full    100G  QSFP 100G CU3M
Hu1/0/29                notconnect    1            full    40G   unknown
Hu1/0/30                notconnect    1            full    40G   unknown
Hu1/0/31                notconnect    1            full    40G   unknown
Hu1/0/32                notconnect    31          full    100G  QSFP 100G CU3M
Hu1/0/1/1              connected     1            full    10G   QSFP 4X10G AOC2M
Hu1/0/1/2              connected     1            full    10G   QSFP 4X10G AOC2M
Hu1/0/1/3              notconnect    1            full    10G   QSFP 4X10G AOC2M
Hu1/0/1/4              notconnect    1            full    10G   QSFP 4X10G AOC2M
Hu1/0/7/1              connected     routed       full    25G   QSFP28 4SFP25G
CU3M
Hu1/0/7/2              connected     routed       full    25G   QSFP28 4SFP25G
CU3M
Hu1/0/7/3              connected     routed       full    25G   QSFP28 4SFP25G
CU3M
Hu1/0/7/4              connected     routed       full    25G   QSFP28 4SFP25G
CU3M

```

The following example shows a sample output of the **hw-module breakout port-num** command after enabling breakout on port 1:

```

Device(config)# hw-module breakout 1

Breakout: Enabling breakout ports on HundredGig1/0/1 successful.

Device(config)#
*Aug 2 06:10:56.281: %TRANSCEIVER-6-REMOVED: R0/0: iomd: Transceiver module removed from
HundredGigE1/0/1
*Aug 2 06:10:56.317: %TRANSCEIVER-6-INSERTED: R0/0: iomd: transceiver module inserted in
HundredGigE1/0/1/1
*Aug 2 06:10:56.319: %TRANSCEIVER-6-INSERTED: R0/0: iomd: transceiver module inserted in
HundredGigE1/0/1/2
*Aug 2 06:10:56.321: %TRANSCEIVER-6-INSERTED: R0/0: iomd: transceiver module inserted in
HundredGigE1/0/1/3
*Aug 2 06:10:56.323: %TRANSCEIVER-6-INSERTED: R0/0: iomd: transceiver module inserted in
HundredGigE1/0/1/4

*Aug 2 06:11:05.927: %LINK-3-UPDOWN: Interface HundredGigE1/0/1/1, changed state to up
*Aug 2 06:11:05.928: %LINK-3-UPDOWN: Interface HundredGigE1/0/1/2, changed state to up
*Aug 2 06:11:06.167: %LINK-3-UPDOWN: Interface HundredGigE1/0/1/3, changed state to up
*Aug 2 06:11:06.172: %LINK-3-UPDOWN: Interface HundredGigE1/0/1/4, changed state to up

*Aug 2 06:11:06.927: %LINEPROTO-5-UPDOWN: Line protocol on Interface HundredGigE1/0/1/1,
changed state to up
*Aug 2 06:11:06.928: %LINEPROTO-5-UPDOWN: Line protocol on Interface HundredGigE1/0/1/2,
changed state to up
*Aug 2 06:11:07.167: %LINEPROTO-5-UPDOWN: Line protocol on Interface HundredGigE1/0/1/3,
changed state to up
*Aug 2 06:11:07.173: %LINEPROTO-5-UPDOWN: Line protocol on Interface HundredGigE1/0/1/4,
changed state to up

```

The following example shows a sample output of the **no hw-module breakout port-num** command after disabling breakout on port 1:

```

Device(config)# no hw-module breakout 1

Breakout: Disabling breakout ports on HundredGig1/0/1 successful.

Device(config)#
*Aug 2 10:25:36.905: %LINEPROTO-5-UPDOWN: Line protocol on Interface HundredGigE1/0/1/1,
changed state to down
*Aug 2 10:25:36.927: %LINEPROTO-5-UPDOWN: Line protocol on Interface HundredGigE1/0/1/2,
changed state to down

```

Example: Configuring 40G and 100G on C9500-32QC

```

*Aug 2 10:25:36.952: %LINEPROTO-5-UPDOWN: Line protocol on Interface HundredGigE1/0/1/3,
changed state to down
*Aug 2 10:25:36.974: %LINEPROTO-5-UPDOWN: Line protocol on Interface HundredGigE1/0/1/4,
changed state to down

*Aug 2 10:25:37.905: %LINK-3-UPDOWN: Interface HundredGigE1/0/1/1, changed state to down
*Aug 2 10:25:37.927: %LINK-3-UPDOWN: Interface HundredGigE1/0/1/2, changed state to down
*Aug 2 10:25:37.951: %LINK-3-UPDOWN: Interface HundredGigE1/0/1/3, changed state to down
*Aug 2 10:25:37.975: %LINK-3-UPDOWN: Interface HundredGigE1/0/1/4, changed state to down

*Aug 2 10:25:38.869: %TRANSCEIVER-6-INSERTED: R0/0: iomd: transceiver module inserted in
HundredGigE1/0/1
*Aug 2 10:25:38.903: %TRANSCEIVER-6-REMOVED: R0/0: iomd: Transceiver module removed from
HundredGigE1/0/1/1
*Aug 2 10:25:38.941: %TRANSCEIVER-6-REMOVED: R0/0: iomd: Transceiver module removed from
HundredGigE1/0/1/2
*Aug 2 10:25:38.978: %TRANSCEIVER-6-REMOVED: R0/0: iomd: Transceiver module removed from
HundredGigE1/0/1/3
*Aug 2 10:25:39.015: %TRANSCEIVER-6-REMOVED: R0/0: iomd: Transceiver module removed from
HundredGigE1/0/1/4

```

Example: Configuring 40G and 100G on C9500-32QC

The following example shows how to enable interface HundredGigabitEthernet 1/0/40. When you enable the interface HundredGigabitEthernet 1/0/40, the corresponding FortyGigabitEthernet 1/0/15 and FortyGigabitEthernet 1/0/16 interfaces, become inactive.

```

Device# configure terminal
Device(config)interface HundredGigabitEthernet 1/0/40
Device(config-if)enable
Device(config-if)end

```

The following example shows how to enable interface FortyGigabitEthernet 1/0/25. When you disable the interface HundredGigabitEthernet 1/0/45, the corresponding FortyGigabitEthernet 1/0/25 and FortyGigabitEthernet 1/0/26 interfaces, become active.

```

Device# configure terminal
Device(config)interface HundredGigabitEthernet 1/0/45
Device(config-if)no enable
Device(config-if)end

```

The following is sample output of all the 40 GigabitEthernet and 100 GigabitEthernet interfaces on C9500-32QC.

```

Device# show interface status

```

Port	Name	Status	Vlan	Duplex	Speed	Type
Fo1/0/1		notconnect	routed	full	40G	QSFP
40G AOC10M						
Fo1/0/2		notconnect	routed	full	40G	QSFP
40G CU3M						
Fo1/0/3		notconnect	routed	full	100G	QSFP
100G CU3M						
Fo1/0/4		notconnect	routed	full	40G	QSFP
40G CU5M						
Fo1/0/5		notconnect	routed	full	100G	QSFP
100G CU3M						
Fo1/0/6		notconnect	routed	full	40G	QSFP

```

40G AOC2M
Fo1/0/7          notconnect  routed      full    100G QSFP
100G CU3M
Fo1/0/8          notconnect  routed      full    40G QSFP
40G CR4 SFP
Fo1/0/9          notconnect  routed      full    100G QSFP
100G CU3M
Fo1/0/10         notconnect  routed      auto    auto unknown
Fo1/0/11         notconnect  routed      full    100G QSFP
100G CU3M
Fo1/0/12         notconnect  routed      auto    auto unknown
Fo1/0/13         notconnect  routed      full    100G QSFP
100G CU3M
    
```

Port	Name	Status	Vlan	Duplex	Speed	Type
Fo1/0/14		notconnect	routed	auto	auto	unknown
Fo1/0/15		notconnect	routed	full	100G	QSFP
100G CU3M						
Fo1/0/16		notconnect	routed	auto	auto	unknown
Fo1/0/17		notconnect	routed	full	40G	QSFP
40G AOC10M						
Fo1/0/18		notconnect	routed	auto	auto	unknown
Fo1/0/19		notconnect	routed	full	40G	QSFP
40G AOC3M						
Fo1/0/20		notconnect	routed	auto	auto	unknown
Fo1/0/21		notconnect	routed	auto	auto	unknown
Fo1/0/22		notconnect	routed	full	40G	QSFP
40G CR4 SFP						
Fo1/0/23		notconnect	routed	full	40G	QSFP
40G CR4 SFP						
Fo1/0/24		notconnect	routed	full	40G	QSFP
40G CR4 SFP						
Fo1/0/25		inactive	routed	auto	auto	unknown
Fo1/0/26		inactive	routed	auto	auto	unknown
Fo1/0/27		inactive	routed	auto	auto	unknown
Fo1/0/28		inactive	routed	full	40G	QSFP
40G CR4 SFP						
Fo1/0/29		inactive	routed	auto	auto	unknown

Port	Name	Status	Vlan	Duplex	Speed	Type
Fo1/0/30		inactive	routed	auto	auto	unknown
Fo1/0/31		inactive	routed	auto	auto	unknown
Fo1/0/32		inactive	routed	full	40G	QSFP
40G CR4 SFP						
Hu1/0/33		inactive	routed	auto	auto	unknown
Hu1/0/34		inactive	routed	auto	auto	unknown
Hu1/0/35		inactive	routed	auto	auto	unknown
Hu1/0/36		inactive	routed	auto	auto	unknown
Hu1/0/37		inactive	routed	auto	auto	unknown
Hu1/0/38		inactive	routed	auto	auto	unknown
Hu1/0/39		inactive	routed	auto	auto	unknown

Example: Configuring the Console Media Type

```

Hu1/0/40                inactive    routed      auto    auto unknown
Hu1/0/41                inactive    routed      auto    auto unknown
Hu1/0/42                inactive    routed      auto    auto unknown
Hu1/0/43                inactive    routed      auto    auto unknown
Hu1/0/44                inactive    routed      auto    auto unknown
Hu1/0/45                notconnect routed      full    40G QSFP
40G CU3M
Hu1/0/46                connected  routed      full    100G QSFP
100G CU3M
Hu1/0/47                connected  routed      full    100G QSFP
100G CU3M
Hu1/0/48                connected  routed      full    100G QSFP
100G CU3M

```

Example: Configuring the Console Media Type

The following example shows how to disable the USB console media type and enable the RJ-45 console media type:

```

Device# configure terminal
Device(config)# line console 0
Device(config-line)# media-type rj45 switch 1

```

The following example shows how to reverse the previous configuration and immediately activate any USB console that is connected:

```

Device# configure terminal
Device(config)# line console 0
Device(config-line)# no media-type rj45 switch 1

```

Example: Configuring USB Inactivity Timeout

The following example shows how to configure the inactivity timeout to 30 minutes:

```

Device# configure terminal
Device(config)# line console 0
Device(config-line)# usb-inactivity-timeout switch 1 30

```

The following example shows how to disable the configuration:

```

Device# configure terminal
Device(config)# line console 0
Device(config-line)# no usb-inactivity-timeout switch 1

```

If there is no (input) activity on a USB console port for the configured number of minutes, the inactivity timeout setting applies to the RJ-45 port, and a log shows this occurrence:

```

*Mar  1 00:47:25.625: %USB_CONSOLE-6-INACTIVITY_DISABLE: Console media-type USB disabled
due to inactivity, media-type reverted to RJ45.

```

At this point, the only way to reactivate the USB console port is to disconnect and reconnect the cable.

When the USB cable on a switch is disconnected and reconnected, a log, which is similar to this, appears:

```
*Mar 1 00:48:28.640: %USB_CONSOLE-6-MEDIA_USB: Console media-type is USB.
```

Additional References for Configuring Interface Characteristics

Related Documents

Related Topic	Document Title
For complete syntax and usage information for the commands used in this chapter.	See the <i>Interface and Hardware Commands</i> section in the <i>Command Reference (Catalyst 9500 Series Switches)</i> .

Feature History for Configuring Interface Characteristics

This table provides release and related information for the features explained in this module.

These features are available in all the releases subsequent to the one they were introduced in, unless noted otherwise.

Release	Feature	Feature Information
Cisco IOS XE Everest 16.5.1a	Interface Characteristics	Interface Characteristics includes interface types, connections, configuration modes, speed, and other aspects of configuring a physical interface on a device. Support for this feature was introduced only on the C9500-12Q, C9500-24Q, C9500-16X and C9500-40X models of the Cisco Catalyst 9500 Series Switches.
Cisco IOS XE Everest 16.6.4	IEEE 802.3x Flow Control	The default value for flowcontrol interface configuration command was modified to on on the C9500-12Q, C9500-24Q, C9500-16X and C9500-40X models of the Cisco Catalyst 9500 Series Switches

Release	Feature	Feature Information
Cisco IOS XE Fuji 16.8.1a	Interface Characteristics	Interface Characteristics includes interface types, connections, configuration modes, speed, and other aspects of configuring a physical interface on a device. Support for this feature was introduced only on the C9500-32C, C9500-32QC, C9500-48Y4C, and C9500-24Y4C models of the Cisco Catalyst 9500 Series Switches.
	Breakout interfaces	Support for breakout interfaces was introduced on the following: <ul style="list-style-type: none"> • Only the first four ports of C9500-12Q, C9500-24Q, C9500-16X and C9500-40X models. • All the ports of the C9500-NM-2Q network module.
Cisco IOS XE Fuji 16.9.1	Breakout interfaces	On Cisco Catalyst 9500 Series Switches, support for breakout configuration was introduced only on the first twelve ports of C9500-24Q, C9500-16X, C9500-40X models.
Cisco IOS XE Gibraltar 16.10.1	Breakout interfaces	On Cisco Catalyst 9500 Series Switches, support for breakout configuration was introduced on the following: <ul style="list-style-type: none"> • The first twenty-four ports of C9500-40X, and all ports of C9500-24Q and C9500-16X models. • C9500-32C model
	Password Authentication on USB 3.0 SSD	Support for configuring password on a USB 3.0 SSD was enabled on the C9500-12Q, C9500-16X, C9500-24Q, C9500-40X models of the Cisco Catalyst 9500 Series Switches.

Release	Feature	Feature Information
Cisco IOS XE Gibraltar 16.11.1	Breakout configuration with Cisco StackWise Virtual	Support for breakout configuration with Cisco StackWise Virtual was enabled on all the models of the Cisco Catalyst 9500 Series Switches.
Cisco IOS XE Bengaluru 17.5.1	Disabling USB interfaces	Support to disable all USB ports on a standalone or stacked device was introduced.
Cisco IOS XE Cupertino 17.7.1	Interface Characteristics	Support for configuration of interface characteristics was introduced on the C9500X-28C8D model of Cisco Catalyst 9500 Series Switches.
	Breakout interfaces	Support for breakout configuration was introduced only on all odd ports on the C9500X-28C8D model of Cisco Catalyst 9500 Series Switches
Cisco IOS XE Cupertino 17.10.1b	Interface Characteristics	Support for configuration of interface characteristics was introduced on the C9500X-60L4D model of Cisco Catalyst 9500 Series Switches.
	Breakout interfaces	Support for breakout configuration was introduced on 400G ports on the C9500X-60L4D model of Cisco Catalyst 9500 Series Switches.

Use the Cisco Feature Navigator to find information about platform and software image support. To access Cisco Feature Navigator, go to [Cisco Feature Navigator](#).

