



## **Cisco UCS C125 M5 Rack Server Node Service Note**

**First Published:** 2018-08-09

**Last Modified:** 2020-09-09

### **Americas Headquarters**

Cisco Systems, Inc.  
170 West Tasman Drive  
San Jose, CA 95134-1706  
USA  
<http://www.cisco.com>  
Tel: 408 526-4000  
800 553-NETS (6387)  
Fax: 408 527-0883

THE SPECIFICATIONS AND INFORMATION REGARDING THE PRODUCTS IN THIS MANUAL ARE SUBJECT TO CHANGE WITHOUT NOTICE. ALL STATEMENTS, INFORMATION, AND RECOMMENDATIONS IN THIS MANUAL ARE BELIEVED TO BE ACCURATE BUT ARE PRESENTED WITHOUT WARRANTY OF ANY KIND, EXPRESS OR IMPLIED. USERS MUST TAKE FULL RESPONSIBILITY FOR THEIR APPLICATION OF ANY PRODUCTS.

THE SOFTWARE LICENSE AND LIMITED WARRANTY FOR THE ACCOMPANYING PRODUCT ARE SET FORTH IN THE INFORMATION PACKET THAT SHIPPED WITH THE PRODUCT AND ARE INCORPORATED HEREIN BY THIS REFERENCE. IF YOU ARE UNABLE TO LOCATE THE SOFTWARE LICENSE OR LIMITED WARRANTY, CONTACT YOUR CISCO REPRESENTATIVE FOR A COPY.

The following information is for FCC compliance of Class A devices: This equipment has been tested and found to comply with the limits for a Class A digital device, pursuant to part 15 of the FCC rules. These limits are designed to provide reasonable protection against harmful interference when the equipment is operated in a commercial environment. This equipment generates, uses, and can radiate radio-frequency energy and, if not installed and used in accordance with the instruction manual, may cause harmful interference to radio communications. Operation of this equipment in a residential area is likely to cause harmful interference, in which case users will be required to correct the interference at their own expense.

The following information is for FCC compliance of Class B devices: This equipment has been tested and found to comply with the limits for a Class B digital device, pursuant to part 15 of the FCC rules. These limits are designed to provide reasonable protection against harmful interference in a residential installation. This equipment generates, uses and can radiate radio frequency energy and, if not installed and used in accordance with the instructions, may cause harmful interference to radio communications. However, there is no guarantee that interference will not occur in a particular installation. If the equipment causes interference to radio or television reception, which can be determined by turning the equipment off and on, users are encouraged to try to correct the interference by using one or more of the following measures:

- Reorient or relocate the receiving antenna.
- Increase the separation between the equipment and receiver.
- Connect the equipment into an outlet on a circuit different from that to which the receiver is connected.
- Consult the dealer or an experienced radio/TV technician for help.

Modifications to this product not authorized by Cisco could void the FCC approval and negate your authority to operate the product.

The Cisco implementation of TCP header compression is an adaptation of a program developed by the University of California, Berkeley (UCB) as part of UCB's public domain version of the UNIX operating system. All rights reserved. Copyright © 1981, Regents of the University of California.

NOTWITHSTANDING ANY OTHER WARRANTY HEREIN, ALL DOCUMENT FILES AND SOFTWARE OF THESE SUPPLIERS ARE PROVIDED "AS IS" WITH ALL FAULTS. CISCO AND THE ABOVE-NAMED SUPPLIERS DISCLAIM ALL WARRANTIES, EXPRESSED OR IMPLIED, INCLUDING, WITHOUT LIMITATION, THOSE OF MERCHANTABILITY, FITNESS FOR A PARTICULAR PURPOSE AND NONINFRINGEMENT OR ARISING FROM A COURSE OF DEALING, USAGE, OR TRADE PRACTICE.

IN NO EVENT SHALL CISCO OR ITS SUPPLIERS BE LIABLE FOR ANY INDIRECT, SPECIAL, CONSEQUENTIAL, OR INCIDENTAL DAMAGES, INCLUDING, WITHOUT LIMITATION, LOST PROFITS OR LOSS OR DAMAGE TO DATA ARISING OUT OF THE USE OR INABILITY TO USE THIS MANUAL, EVEN IF CISCO OR ITS SUPPLIERS HAVE BEEN ADVISED OF THE POSSIBILITY OF SUCH DAMAGES.

Any Internet Protocol (IP) addresses and phone numbers used in this document are not intended to be actual addresses and phone numbers. Any examples, command display output, network topology diagrams, and other figures included in the document are shown for illustrative purposes only. Any use of actual IP addresses or phone numbers in illustrative content is unintentional and coincidental.

All printed copies and duplicate soft copies of this document are considered uncontrolled. See the current online version for the latest version.

Cisco has more than 200 offices worldwide. Addresses and phone numbers are listed on the Cisco website at [www.cisco.com/go/offices](http://www.cisco.com/go/offices).

Cisco and the Cisco logo are trademarks or registered trademarks of Cisco and/or its affiliates in the U.S. and other countries. To view a list of Cisco trademarks, go to this URL: <https://www.cisco.com/c/en/us/about/legal/trademarks.html>. Third-party trademarks mentioned are the property of their respective owners. The use of the word partner does not imply a partnership relationship between Cisco and any other company. (1721R)

© 2018– 2020 Cisco Systems, Inc. All rights reserved.



# CHAPTER 1

## Overview

- [Cisco UCS C125 M5 Software/Firmware Requirements, on page 1](#)
- [Cisco UCS C125 M5 Compute Node External Features, on page 2](#)
- [Externally Viewable LEDs, on page 3](#)
- [Local KVM Console Connection, on page 4](#)
- [C125 M5 Compute Node Internal Component Locations, on page 5](#)
- [C125 Compute Node Specifications, on page 6](#)

## Cisco UCS C125 M5 Software/Firmware Requirements

The system firmware and software requirements for using the Cisco UCS C125 M5 compute nodes are listed in the following table.

**Table 1: Minimum Levels for C125 M5 Server Nodes**

Software or Firmware	Minimum Version
Cisco IMC	4.1(2a)
BIOS	4.1(2a)
Cisco UCS Manager (UCS Manager-controlled system only)	4.1(2a)



### Caution

You must upgrade your server firmware to the required minimum level before you upgrade to the Second Generation AMD EPYC processors that are supported in this server. Older firmware versions cannot recognize the new CPUs and this would result in a non-bootable server.

# Cisco UCS C125 M5 Compute Node External Features

Figure 1: C125 M5 Rear Panel

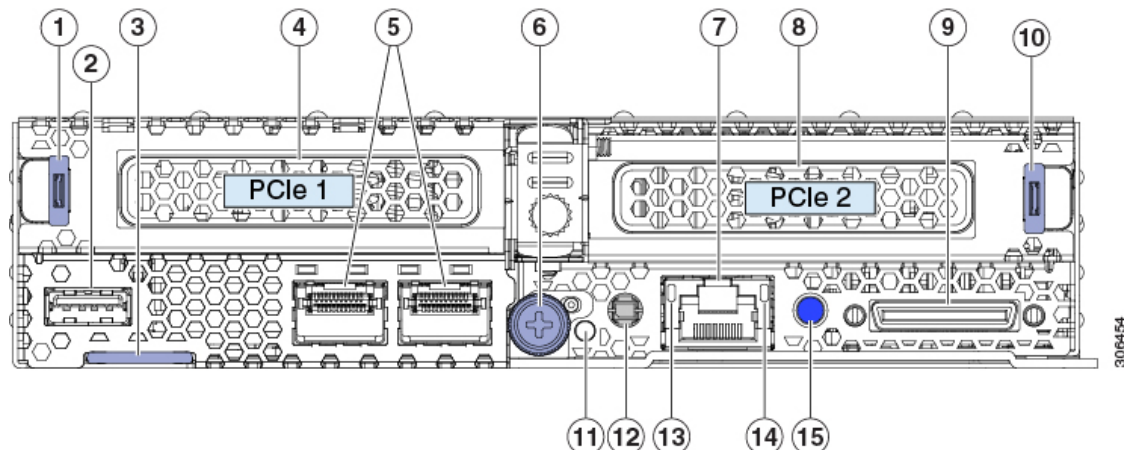

<b>1</b>	PCIe riser 1 handle	<b>8</b>	PCIe riser 2/slot 2 (half-height, half length, x16 slot)
<b>2</b>	USB 3.0 port	<b>9</b>	KVM local console port Used with KVM cable that provides one DB-15 VGA, one DB-9 serial, and two USB connectors.
<b>3</b>	Pull-out asset tag	<b>10</b>	PCIe riser 2 handle
<b>4</b>	PCIe riser 1/slot 1 (half-height, half length, x8 slot)	<b>11</b>	Node health LED
<b>5</b>	OCP adapter card Ethernet LAN ports Depending on which adapter is installed, these ports can be either: <ul style="list-style-type: none"> <li>• Dual 10 Gb Base-T (RJ-45 connectors)</li> <li>• Dual 10/25 Gb SFP28 (shown)</li> <li>• Single 100 Gb Infiniband/Ethernet</li> </ul>	<b>12</b>	Node Power button/Power status LED Use this button to shut down power to an individual node without powering off the chassis.
<b>6</b>	Node securing thumbscrew and release lever	<b>13</b>	1 Gb Ethernet management port link speed LED
<b>7</b>	1 Gb Ethernet dedicated management port	<b>14</b>	1 Gb Ethernet management port link status LED
-		<b>15</b>	Node locator button/LED

## Externally Viewable LEDs

The LEDs below repeat on all nodes. Other LEDs will vary, depending on which adapter cards are installed.

**Table 2: C125 M5 Compute Node Externally Viewable LEDs**

LED	Definition of States
Node power status button/LED	<ul style="list-style-type: none"> <li>• Off—There is no power to the node.</li> <li>• Amber—The node is in standby power mode. Power is supplied only to the Cisco IMC.</li> <li>• Green—The node is in main power mode. Power is supplied to all node components.</li> </ul>
Node locator button/LED Activating the beacon LED on any installed compute node also activates the locator beacon on the front of the chassis.	<ul style="list-style-type: none"> <li>• Off—The locator LED is not activated.</li> <li>• Blue, blinking—The locator LED is activated.</li> </ul>
Node health LED	<ul style="list-style-type: none"> <li>• Green—The node is operating normally.</li> <li>• Amber—The node is in a degraded condition (for example, one or more of the following conditions): <ul style="list-style-type: none"> <li>• Faulty or mismatched CPUs</li> <li>• DIMM failure</li> <li>• Failed drive in a RAID configuration</li> </ul> </li> <li>• Amber, Blinking—The node is in a critical condition (for example, one or more of the following conditions): <ul style="list-style-type: none"> <li>• Boot failure</li> <li>• Fatal CPU and/or bus errors detected</li> <li>• Fatal uncorrectable memory errors</li> <li>• Excessive thermal conditions</li> </ul> </li> </ul>
1 Gb Ethernet management port link speed	<ul style="list-style-type: none"> <li>• Off—Link speed is 10 Mbps.</li> <li>• Amber—Link speed is 100 Mbps.</li> <li>• Green—Link speed is 1 Gbps.</li> </ul>

LED	Definition of States
1 Gb Ethernet management port link status	<ul style="list-style-type: none"> <li>• Off—No link is present.</li> <li>• Green—Link is active.</li> <li>• Green, Blinking—Traffic is present on the active link.</li> </ul>

## Local KVM Console Connection

The local console connector allows a direct connection to a node to allow management tasks to be done locally rather than remotely. The port uses the KVM cable N20-BKVM; it has a DB-9 serial connector, a DB-15 VGA connector for a monitor, and dual USB ports for a keyboard and mouse.

Figure 2: KVM Cable for Local Connection

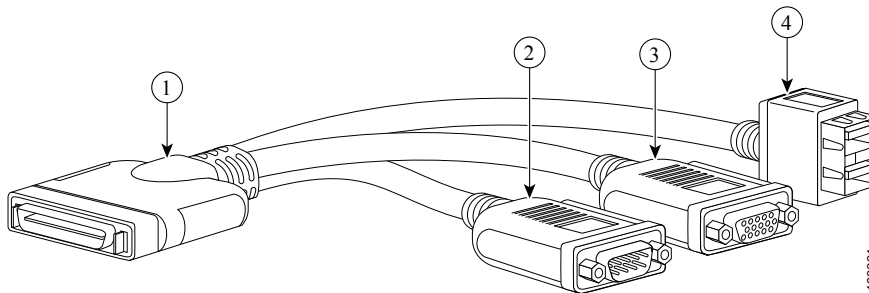

<b>1</b>	Connector to compute node local console connection	<b>2</b>	DB-9 serial connector
<b>3</b>	DB-15 VGA connector for a monitor	<b>4</b>	Two-port USB connector for a mouse and keyboard

# C125 M5 Compute Node Internal Component Locations

Figure 3: C125 M5 Compute Node Internal Components

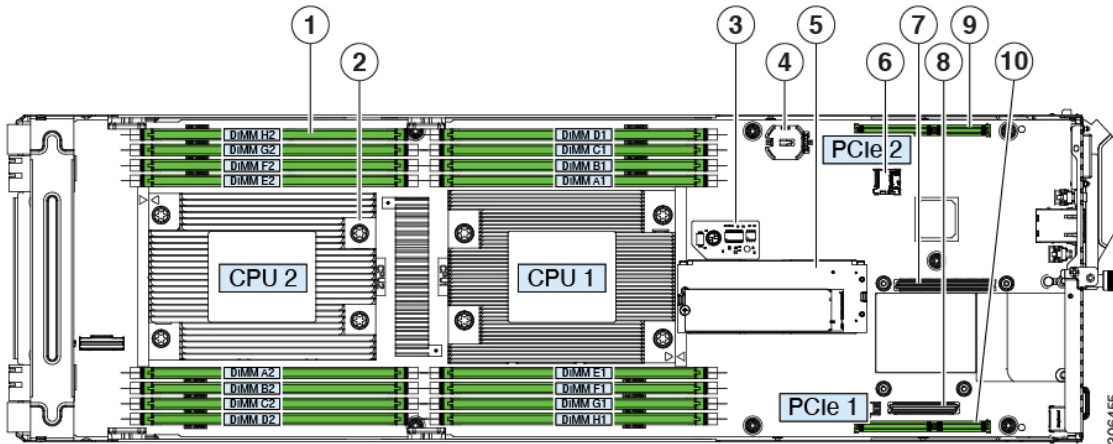

1	DIMM sockets (each CPU supports 8 sockets, 16 total)	6	Micro-SD card socket on server board
2	AMD EPYC 7001 Series (Naples) and Second Generation AMD EPYC 7002 Series (Rome) CPUs and heatsinks (one or two)  The front and rear CPUs use different heatsinks.	7	OCP adapter card socket A  OCP adapter cards that require a x8 lane plug into only socket A. OCP cards that require a x16 lane plug into both sockets A and B.
3	Trusted platform module (TPM) location on server board	8	OCP adapter card socket B  OCP adapter cards that require a x8 lane plug into only socket A. OCP cards that require a x16 lane plug into both sockets A and B.
4	Real-time clock (RTC) battery CR2032 horizontal socket location on server board	9	Socket for PCIe riser 2/ PCIe slot 2 (riser not shown in this view)  Riser 2 plugs into a board socket to provide one horizontal PCIe slot (half-height, half length, x16 slot).
5	Mini-storage module socket on server board. Supports: <ul style="list-style-type: none"><li>• an SD card carrier with two slots for SD cards</li><li>• an M.2 SSD carrier with two slots for M.2 SATA SSDs</li><li>• a Cisco Boot-Optimized M.2 RAID Controller</li></ul>	10	Socket for PCIe riser 1/PCIe slot 1 (riser not shown in the is view)  Riser 1 plugs into this socket to provide one horizontal PCIe slot (half-height, half length, x8 slot).  This is the required slot for a SAS RAID controller. The controller supports the six front-loading drives in the chassis that correspond to the node's position (group 1, 2, 3, or 4).  Riser 1 also includes one x8 Slimline connector for pass-through (JBOD) SATA drive control.

# C125 Compute Node Specifications

This topic lists the physical and environmental specifications for the compute node.

## Physical Specifications

The following table lists the physical specifications for the C125 compute node.

**Table 3: Physical Specifications**

Description	Specification
Height	1.59 in (40.39 mm)
Width	6.8 in (172.7 mm)
Depth (length)	22.99 in (583.9 mm)
Weight, fully configured	Fully configured: 9.75 lbs (4.42 kg) Actual weight depends on which components are installed.

## Environmental Specifications

The following table lists the environmental requirements for the C125 compute node.

**Table 4: Physical Specifications**

Description	Specification
Temperature, Operating	41 to 95°F (5 to 35°C) Derate the maximum temperature by 1°C per every 305 meters of altitude above sea level.
Temperature, non-operating (when the server is stored or transported)	-40 to 149°F (-40 to 65°C)
Humidity (RH), operating	10 to 90%
Humidity (RH), non-operating (when the server is stored or transported)	5 to 93%
Altitude, operating	0 to 10,000 feet
Altitude, non-operating (when the server is stored or transported)	0 to 40,000 feet





## CHAPTER 2

# Replacing a C125 M5 Compute Node

This chapter explains how to shut down and replace a Cisco UCS C125 M5 compute node in a Cisco UCS C4200 Server Chassis. Instructions for optionally exporting and importing a Cisco IMC configuration are also included.

- [Shutting Down and Removing Power From a Node, on page 7](#)
- [Replacing a Node in a Chassis, on page 10](#)

## Shutting Down and Removing Power From a Node

Compute nodes include a physical power button so that you can shut down the individual node and any installed operating system by using the power button on the node or the software interface.



**Caution** Always shut down the node before removing it from the chassis, as described in the procedures. Failure to shut down the node before removal results in the corresponding RAID supercap cache being discarded and other data might be lost.



**Caution** To avoid data loss or damage to your operating system, you should always invoke a graceful shutdown.

The compute node can run in either of two power modes:

- Main power mode—Power is supplied to all server components and any operating system on your drives can run.
- Standby power mode—Power is supplied only to the service processor and certain components. It is safe for the operating system and data to remove the node from the chassis in this mode.

## Shutting Down a Node Using the Power Button

**Step 1** Check the color of the Power button/LED on the face of the compute node:

- Amber—The node is already in standby mode and you can safely remove it from the chassis.

- Green—The node is in main power mode and must be shut down before you can safely remove it from the chassis.

**Step 2** Invoke a graceful shutdown by pressing and releasing the **Power** button.

**Caution** To avoid data loss or damage to your operating system, you should always invoke a graceful shutdown of the operating system. Do not power off a node if any firmware or BIOS updates are in progress.

With a graceful shutdown, the operating system performs a graceful shutdown and the node goes to standby mode, which is indicated by an amber Power button/LED.

As a best practice, attempt a graceful shutdown first. As an option, you can also invoke an Emergency shutdown, by pressing and holding the **Power** button for 4 seconds to force the main power off and immediately enter standby mode.

## Shutting Down a Node Using The Cisco IMC GUI

You must log in with user or admin privileges to perform this task.

**Step 1** In the Navigation pane, click the **Chassis** tab.

**Step 2** On the Chassis tab, click **Summary**.

**Step 3** In the toolbar above the work pane, click the **Host Power** link.

The Server Power Management dialog opens. This dialog lists all servers that are present in the system.

**Step 4** In the **Server Power Management** dialog, select Shut Down for the server that you want to shut down. Shut Down performs a graceful shutdown of the operating system.

**Note** To avoid data loss or damage to your operating system, you should always invoke a graceful shutdown of the operating system. Do not power off a node if any firmware or BIOS updates are in progress.

- It is safe to remove the node from the chassis when the Chassis Status pane shows the Power State as Off for the node that you are removing.
- The physical power button on the node also turns amber when it is safe to remove the node from the chassis.
- The **Server Power Management** dialog also has a Power Off option, but you should use Shut down as a best practice. The Power Off option is a forced shutdown that powers off the chosen node even if tasks are running on that server. Use Power Off only if the Shut Down option does not complete successfully.

## Shutting Down Using The Cisco IMC CLI

You must log in with user or admin privileges to perform this task.

**Step 1** At the server prompt, enter:

**Example:**

```
server# scope chassis
```

**Step 2** At the chassis prompt, enter:

**Example:**

```
/chassis# power shutdown
```

The operating system performs a graceful shutdown and the node goes to standby mode, which is indicated by an amber Power button/LED.

---

## Shutting Down a Node Using The Cisco UCS Manager Equipment Tab

You must log in with user or admin privileges to perform this task.

---

**Step 1** In the Navigation pane, click **Equipment**.

**Step 2** Expand **Equipment > Chassis > Chassis Number > Servers**.

**Step 3** Choose the node that you want to shut down.

**Step 4** In the Work pane, click the **General** tab.

**Step 5** In the Actions area, click **Shutdown Server**.

**Step 6** If a confirmation dialog displays, click **Yes**.

The operating system performs a graceful shutdown and the server goes to standby mode, which is indicated by an amber Power button/LED.

---

## Shutting Down a Node Using The Cisco UCS Manager Service Profile

You must log in with user or admin privileges to perform this task.

---

**Step 1** In the Navigation pane, click **Servers**.

**Step 2** Expand **Servers > Service Profiles**.

**Step 3** Expand the node for the organization that contains the associated service profile.

**Step 4** Choose the service profile of the node that you are shutting down.

**Step 5** In the **Work** pane, click the **General** tab.

**Step 6** In the **Actions** area, click **Shutdown Server**.

**Step 7** If a confirmation dialog displays, click **Yes**.

The operating system performs a graceful shutdown and the server goes to standby mode, which is indicated by an amber Power button/LED.

---

# Replacing a Node in a Chassis

Use the procedures in this section to remove and replace a compute node in a chassis.

## C125 M5 Compute Node Population Rules

Observe the following rules:

- The C4200 Server Chassis can use 2, 3, or 4 compute nodes.
- Install compute nodes to the lowest-numbered bays first.
- Keep a node blanking panel (UCSC-NBLKD-C4200) in any unused node bays to ensure adequate airflow and cooling.
- Front-loading drives and supercap units in the chassis are not seen by the system unless they correspond to an installed compute node. That is, drives in group 1 and supercap 1 must have node 1 installed, and so on.

## Replacing a Node

The compute node is accessed from the rear of the system chassis, so you do not have to pull the system out from the rack.



---

**Note** You do not have to remove power from the system chassis in this procedure. Replacement with the chassis powered on is supported if you shut down the server node before removal.

---



---

**Caution** Always shut down the node before removing it from the chassis, as described in the procedures. Failure to shut down the node before removal results in the corresponding RAID supercap cache being discarded and other data might be lost.

---



---

**Caution** Before you replace a server node, export and save the Cisco IMC configuration from the node if you want that same configuration on the new node. You can import the saved configuration to the new replacement node after you install it. This chapter contains procedures for exporting and importing a configuration.

---

- 
- Step 1** Optional—Export the Cisco IMC configuration from the server node that you are replacing so that you can import it to the replacement server node. If you choose to do this, use the procedure in [Exporting Cisco IMC Configuration From a Node, on page 11](#), then return to the next step.
- Step 2** Shut down the node by using the software interface or by pressing the node power button, as described in [Shutting Down and Removing Power From a Node, on page 7](#).
- Step 3** Disconnect any cables from ports on the node or installed cards.

- Step 4** Remove the node from the system:
- Loosen the captive thumbscrew on the ejector lever of the node.
  - Rotate the ejector lever to the outside to evenly disengage the node from its midplane connectors.
  - Pull the node straight out from the system.
- Step 5** Install a new node:
- With the ejector lever fully open, align the new node with the empty bay.
  - Push the server node into the bay until it engages with the midplane connectors and is flush with the chassis.
  - Place your fingers on the flat area of the faceplate near the thumbscrew, and push to completely seat the module.
  - Rotate the ejector lever toward the center until it lays flat.
  - Tighten the thumbscrew on the ejector lever to secure the node in the chassis bay.
- Step 6** Connect any cables that you removed to the new node.
- Step 7** Power on the server node.
- Step 8** Perform initial setup on the new server node to assign an IP address and your other preferred network settings. See Initial System Setup in the C4200 Installation Guide.
- Step 9** Optional—Import the Cisco IMC configuration that you saved in step 1. If you choose to do this, use the procedure in [Importing Cisco IMC Configuration to a Node, on page 12](#).

## Exporting Cisco IMC Configuration From a Node

This operation can be performed using either the GUI or CLI interface of the Cisco IMC. The example in this procedure uses the CLI commands. For more information, see *Exporting a Cisco IMC Configuration* in the CLI and GUI guides here: [Configuration Guides](#).

**Step 1** Log in to the IP address and CLI interface of the node that you are replacing.

**Step 2** Enter the following commands as you are prompted:

```
Server# scope cimc
Server /cimc# scope import-export
Server /cimc/import-export# export-config <protocol> <ip-address> <path-and-filename>
```

**Step 3** Enter the user name, password, and pass phrase.

This sets the user name, password, and pass phrase for the file that you are exporting. The export operation begins after you enter a pass phrase, which can be anything that you choose.

To determine whether the export operation has completed successfully, use the **show detail** command. To abort the operation, type CTRL+C.

The following is an example of an export operation. In this example, the TFTP protocol is used to export the configuration to IP address 192.0.2.34, in file /ucs/backups/cimc5.xml.

```
Server# scope cimc
Server /cimc # scope import-export
Server /cimc/import-export # export-config tftp 192.0.2.34 /ucs/backups/cimc5.xml
Username:xxxx
Password:****
Passphrase:***
Export config started. Please check the status using "show detail".
Server /cimc/import-export # show detail
Import Export:
```

```

Operation: EXPORT
Status: COMPLETED
Error Code: 100 (No Error)
Diagnostic Message: NONE

```

---

## Importing Cisco IMC Configuration to a Node

This operation can be performed using either the GUI or CLI interface of the Cisco IMC. The example in this procedure uses the CLI commands. For more information, see *Importing a Cisco IMC Configuration* in the CLI and GUI guides for S3260 Storage Servers here: [Configuration Guides](#).

---

**Step 1** SSH into the CLI interface of the new server node.

**Step 2** Enter the following commands as you are prompted:

```

Server# scope cimc
Server /cimc# scope import-export
Server /cimc/import-export# import-config <protocol> <ip-address> <path-and-filename>

```

**Step 3** Enter the user name, password, and pass phrase.

This should be the user name, password, and pass phrase that you used during the export operation. The import operation begins after you enter the pass phrase.

The following is an example of an import operation. In this example, the TFTP protocol is used to import the configuration to the server node from IP address 192.0.2.34, from file /ucs/backups/cimc5.xml.

```

Server# scope cimc
Server /cimc # scope import-export
Server /cimc/import-export # import-config tftp 192.0.2.34 /ucs/backups/cimc5.xml
Username:xxxx
Password:****
Passphrase:***
Export config started. Please check the status using "show detail".
Server /cimc/import-export # show detail
Import Export:
Operation: IMPORT
Status: COMPLETED
Error Code: 100 (No Error)
Diagnostic Message: NONE

```

---



## CHAPTER 3

# Replacing Node Components

---

This chapter contains procedures for replacing components that are internal to the node.



**Note** For replacement of components that are native to the C4200 Server Chassis (storage drives, supercap units, and power supplies), see the C4200 HIG.

---

- [C125 M5 Compute Node Internal Component Locations, on page 14](#)
- [Required Equipment For Service Procedures, on page 15](#)
- [Replacing Memory DIMMs, on page 15](#)
- [Replacing CPUs and Heatsinks, on page 18](#)
- [Installing and Enabling a TPM, on page 25](#)
- [Replacing the RTC Battery, on page 28](#)
- [Replacing a Mini-Storage Module, on page 29](#)
- [Replacing a Micro SD Card, on page 36](#)
- [Replacing a PCIe Card, on page 38](#)
- [Replacing a PCIe Riser, on page 41](#)
- [Replacing a Storage Controller Card, on page 43](#)
- [Replacing an OCP Adapter Card, on page 46](#)
- [Recycling the PCB Assembly \(PCBA\), on page 49](#)

# C125 M5 Compute Node Internal Component Locations

Figure 4: C125 M5 Compute Node Internal Components

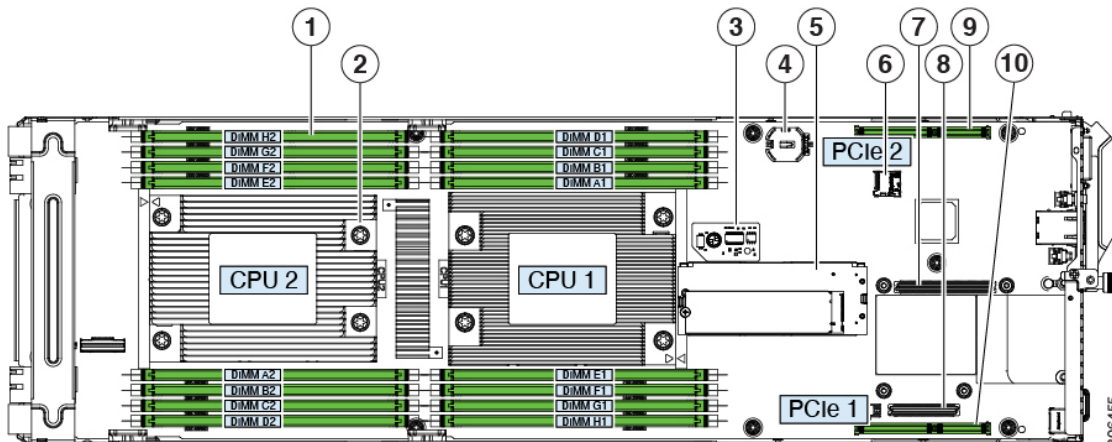

1	DIMM sockets (each CPU supports 8 sockets, 16 total)	6	Micro-SD card socket on server board
2	AMD EPYC 7001 Series (Naples) and Second Generation AMD EPYC 7002 Series (Rome) CPUs and heatsinks (one or two) The front and rear CPUs use different heatsinks.	7	OCP adapter card socket A OCP adapter cards that require a x8 lane plug into only socket A. OCP cards that require a x16 lane plug into both sockets A and B.
3	Trusted platform module (TPM) location on server board	8	OCP adapter card socket B OCP adapter cards that require a x8 lane plug into only socket A. OCP cards that require a x16 lane plug into both sockets A and B.
4	Real-time clock (RTC) battery CR2032 horizontal socket location on server board	9	Socket for PCIe riser 2/ PCIe slot 2 (riser not shown in this view) Riser 2 plugs into a board socket to provide one horizontal PCIe slot (half-height, half length, x16 slot).
5	Mini-storage module socket on server board. Supports: <ul style="list-style-type: none"> <li>• an SD card carrier with two slots for SD cards</li> <li>• an M.2 SSD carrier with two slots for M.2 SATA SSDs</li> <li>• a Cisco Boot-Optimized M.2 RAID Controller</li> </ul>	10	Socket for PCIe riser 1/PCIe slot 1 (riser not shown in the is view) Riser 1 plugs into this socket to provide one horizontal PCIe slot (half-height, half length, x8 slot). This is the required slot for a SAS RAID controller. The controller supports the six front-loading drives in the chassis that correspond to the node's position (group 1, 2, 3, or 4). Riser 1 also includes one x8 Slimline connector for pass-through (JBOD) SATA drive control.



## Required Equipment For Service Procedures

The following tools and equipment are used to perform the procedures in this chapter:

- T-20 Torx driver (for CPU and heatsink replacement)
- #1 Phillips-head screwdriver for M.2 SSD replacement.
- #2 Phillips-head screwdriver for PCIe riser/PCIe card replacement.
- ¼-inch (or equivalent) flat-head screwdriver (for TPM installation)
- Electrostatic discharge (ESD) strap or other grounding equipment such as a grounded mat

## Replacing Memory DIMMs

There are 16 DIMM sockets on the node board, 8 DIMMs controlled by each CPU.



---

**Caution** DIMMs and their sockets are fragile and must be handled with care to avoid damage during installation.

---



---

**Caution** Cisco does not support third-party DIMMs. Using non-Cisco DIMMs in the system might result in system problems or damage to the motherboard.

---



---

**Note** To ensure the best system performance, it is important that you are familiar with memory performance guidelines and population rules before you install or replace the memory.

---

## DIMM Sockets

A node has 16 DIMM sockets (8 for each CPU). The following figure shows the DIMM sockets and how they are numbered on a C125 M5 compute node board.

The DIMM channels consist of two lettered slots (for example, A1, A2). Note however that the two slots in a channel are placed on opposite sides of the two CPUs.

Figure 5: DIMM and CPU Numbering

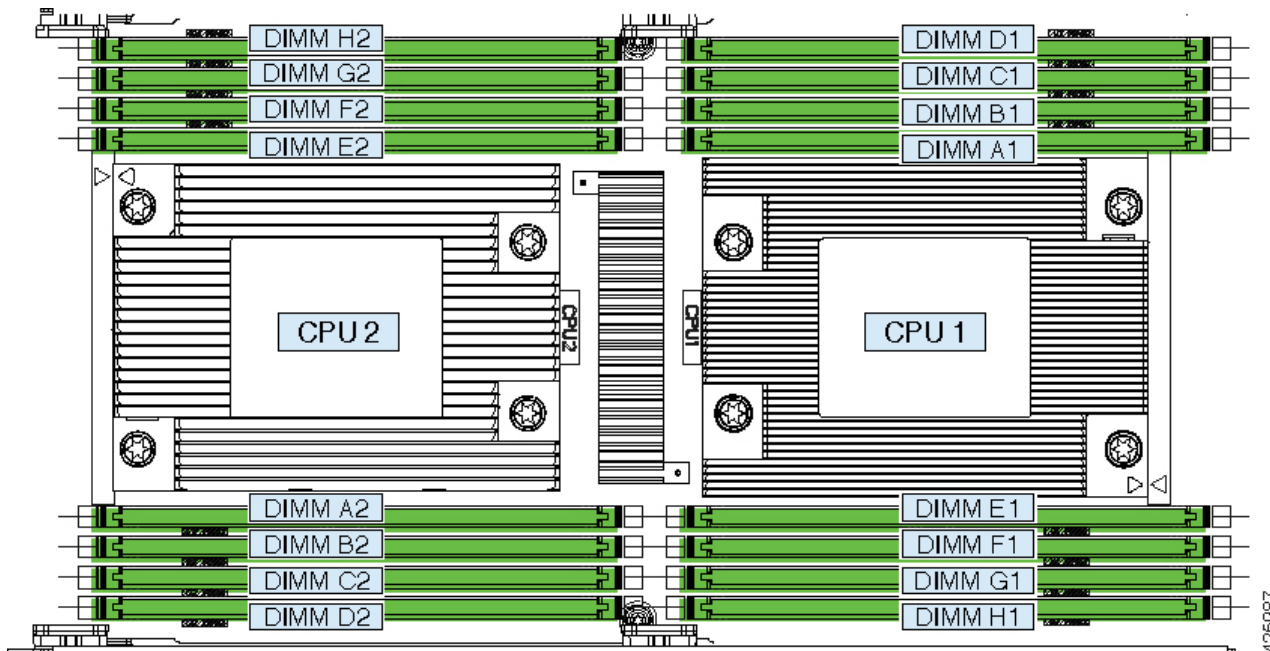

## DIMM Population Rules

AMD CPUs do not require a specific loading order for memory DIMMs. However, observe the following recommended guidelines for best performance:

- Any unused DIMM socket must have a DIMM blanking panel installed to ensure adequate airflow and cooling.
- For best performance, each CPU should have at least four DIMMs installed.
- You must populate the DIMM slots of each CPU identically. Therefore, a two-CPU node must always have an even number of DIMMs. For optimal performance, populate DIMMs in the order shown in the following table, depending on the number of DIMMs per CPU.
  - In a single-CPU node, populate only the CPU 1 slots.
  - In a two-CPU node, populate slots for both CPUs evenly, as described in the table below.

Table 5: DIMM Population Order

Number of DIMMs Per CPU	CPU 1 Slots (In a single-CPU node, populate only these slots)	CPU 2 Slots
1	A1	A2
2	A1, E1	A2, E2
3	A1, E1, C1	A2, E2, C2

Number of DIMMs Per CPU	CPU 1 Slots (In a single-CPU node, populate only these slots)	CPU 2 Slots
4	A1, E1, C1, G1	A2, E2, C2, G2
5	A1, E1, C1, G1, B1	A2, E2, C2, G2, B2
6	A1, E1, C1, G1, B1, F1	A2, E2, C2, G2, B2, F2
7	A1, E1, C1, G1, B1, F1, D1	A2, E2, C2, G2, B2, F2, D2
8	A1, E1, C1, G1, B1, F1, D1, H1	A2, E2, C2, G2, B2, F2, D2, H2

- Observe the DIMM mixing rules in the following table.

**Table 6: DIMM Mixing Rules**

DIMM Parameter	Rules
DIMM capacity	You can mix different capacity DIMMs.
DIMM speed	You can mix speeds, but DIMMs will run at the speed of the slowest DIMMs/CPUs.
DIMM type	You cannot mix DIMM types.

## Replacing DIMMs



**Caution** Always shut down the node before removing it from the chassis, as described in the procedures. Failure to shut down the node before removal results in the corresponding RAID supercap cache being discarded and other data might be lost.

- Step 1** Shut down the server node by using the software interface or by pressing the node power button, as described in [Shutting Down and Removing Power From a Node, on page 7](#).
- Step 2** Disconnect any cables from ports on the node or installed cards.
- Step 3** Remove the node from the system:
- Loosen the captive thumbscrew on the ejector lever of the node.
  - Rotate the ejector lever to the outside to evenly disengage the node from its midplane connectors.
  - Pull the node straight out from the system.
- Step 4** Locate the faulty DIMM and remove it from the socket on the riser by opening the ejector levers at both ends of the DIMM socket.
- Step 5** Install a new DIMM:
- Note** Before installing DIMMs, refer to the population guidelines. See [DIMM Population Rules, on page 16](#).

- a) Align the new DIMM with the socket on the riser. Use the alignment key in the DIMM socket to correctly orient the DIMM.
- b) Push the DIMM into the socket until it is fully seated and the ejector levers on either side of the socket lock into place.

**Step 6** Return the server node to the chassis:

- a) With the ejector lever fully open, align the new node with the empty bay.
- b) Push the server node into the bay until it engages with the midplane connectors and is flush with the chassis.
- c) Rotate the ejector lever toward the center until it lays flat.
- d) Tighten the thumbscrew on the ejector lever to secure the node in the chassis bay.

**Step 7** Reconnect any cables that you removed.

**Step 8** Power on the server node.

## Replacing CPUs and Heatsinks

Each node contains one or two AMD CPUs.

### CPU Configuration Rules

- A node can operate with one or two CPUs.
- In a single-CPU configuration, populate only CPU1.
- The maximum supported wattage for the node's CPUs is 200W, which are capped to run at 180W.
- In a single-CPU configuration, only the DIMM slots for CPU 1 (DIMM A1 – H1) are supported.

### Tools Required For CPU Replacement

You need the following tools and equipment for this procedure:

- T-20 Torx driver (for heatsink and CPU socket screws).
- Heatsink cleaning kit—Supplied with replacement CPU. Orderable separately as Cisco PID UCSX-HSCK=.

One cleaning kit can clean up to four CPUs.

- Thermal interface material (TIM)—Syringe supplied with replacement CPU. Use only if you are reusing your existing heatsink (new heatsinks have a pre-applied pad of TIM). Orderable separately as Cisco PID UCS-CPU-TIM=.

One TIM kit covers one CPU.

See also [Additional CPU-Related Parts to Order with RMA Replacement CPUs or RMA Nodes](#), on page 24.

## Replacing a CPU and Heatsink



---

**Caution** CPUs and their sockets are fragile and must be handled with extreme care to avoid damaging pins. The CPUs must be installed with heatsinks and thermal interface material to ensure cooling. Failure to install a CPU correctly might result in damage to the server node.

---



---

**Caution** Always shut down the node before removing it from the chassis, as described in the procedures. Failure to shut down the node before removal results in the corresponding RAID supercap cache being discarded and other data might be lost.

---

---

**Step 1** Shut down the node by using the software interface or by pressing the node power button, as described in [Shutting Down and Removing Power From a Node, on page 7](#).

**Step 2** Disconnect any cables from ports on the node or installed cards.

**Step 3** Remove the node from the system:

- a) Loosen the captive thumbscrew on the ejector lever of the node.
- b) Rotate the ejector lever to the outside to evenly disengage the node from its midplane connectors.
- c) Pull the node straight out from the system.

**Step 4** Remove the heatsink from the CPU that you are replacing:

- a) Use a T-20 Torx driver to loosen the four captive screws that secure the heatsink.

**Note** Alternate loosening the heatsink screws evenly so that the heatsink remains level as it is raised. Loosen the heatsink nuts in the order shown on the heatsink label (4, 3, 2, 1).

- b) Lift straight up on the heatsink and set it heatsink-down on an antistatic surface. Use caution to avoid damaging the heatsink-to-CPU surface.

Figure 6: Removing the Heatsink

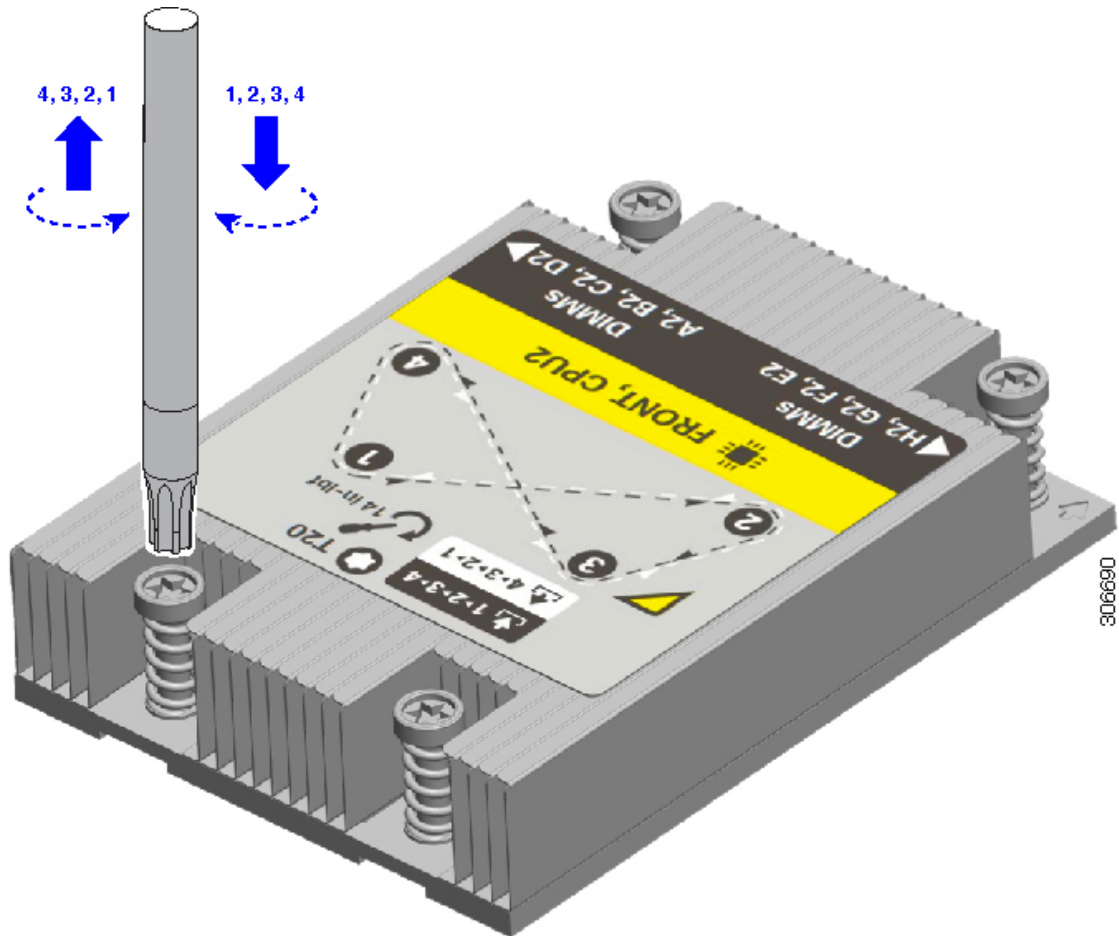
**Step 5**

Remove the CPU from the socket:

- a) Use the T-20 Torx driver to loosen the three captive socket-frame screws in this order: 3, 2, 1.

Figure 7: Loosening the Socket Frame Screws

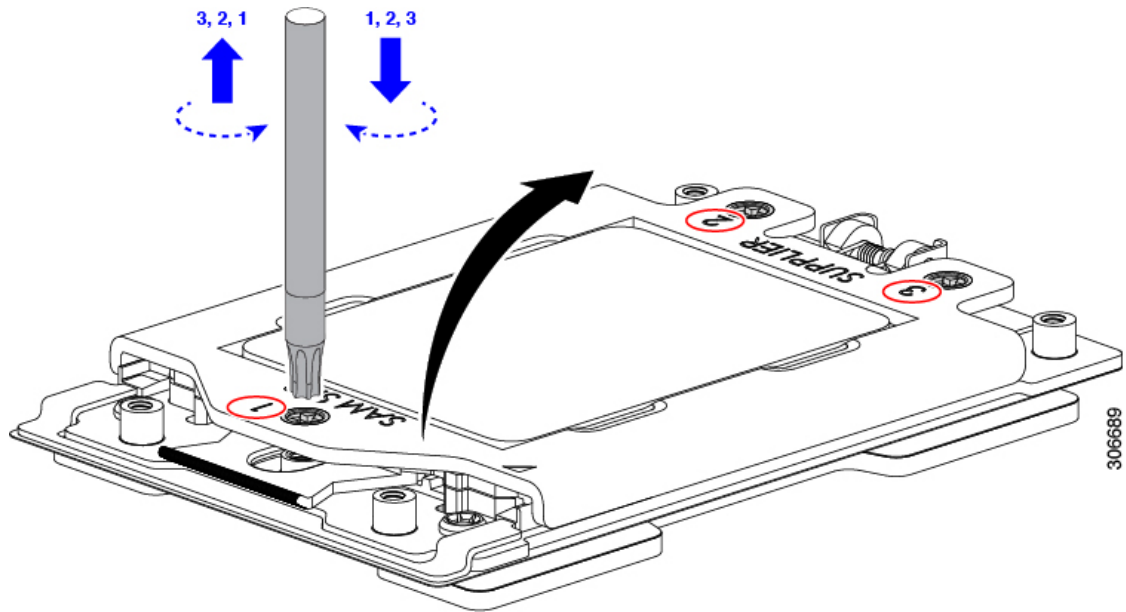

- b) Pivot the hinged socket frame and rail frame to the upright position.
- c) Grasp the CPU only by the handling tab that is on its carrier frame and pull straight up to remove the CPU from the rail frame.

*Figure 8: Removing the CPU From the Socket*



<b>1</b>	Rail frame in open position	<b>3</b>	CPU in carrier frame
<b>2</b>	Socket frame in open position	<b>4</b>	Handling tab on CPU carrier frame

### Step 6

Install the new CPU:

**Caution** The CPU contacts and pins are extremely fragile. In this step, use extreme care to avoid touching or damaging the CPU contacts or the CPU socket pins.

**Note** Ensure that you are following the [CPU Configuration Rules, on page 18](#).

- Grasping the CPU only by the handling tab on its carrier frame, carefully slide it down into the open rail frame.
- Gently close the rail frame and the socket frame down to the flat, closed position.
- Tighten the three screws on the socket frame in this order: 1, 2, 3.

### Step 7

Apply new TIM to the heatsink:

**Note** The heatsink must have new TIM on the heatsink-to-CPU surface to ensure proper cooling and performance.

- If you are installing a new heatsink, it is shipped with a pre-applied pad of TIM. Go to step 7.
  - If you are reusing a heatsink, you must remove the old TIM from the heatsink and then apply new TIM to the CPU surface from the supplied syringe. Continue with step a below.
- Apply the cleaning solution that is included with the heatsink cleaning kit (UCSX-HSCK=) to the old TIM on the heatsink and let it soak for a least 15 seconds.
  - Wipe all of the TIM off the heatsink using the soft cloth that is included with the heatsink cleaning kit. Be careful to avoid scratching the heatsink surface.
  - Using the syringe of TIM provided with the new CPU (UCS-CPU-TIM=), apply 1.5 cubic centimeters (1.5ml) of thermal interface material to the top of the CPU. Use the pattern shown below to ensure even coverage.

**Figure 9: Thermal Interface Material Application Pattern**

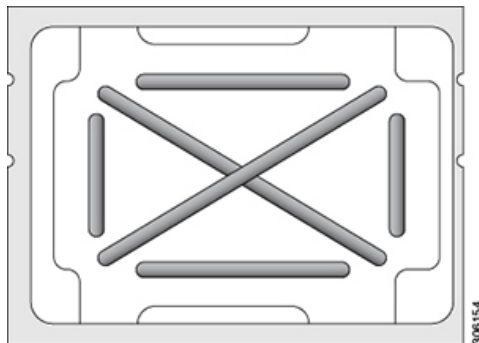

### Step 8

Install the heatsink to the CPU:

**Note** The front and rear CPUs use different heatsinks. The rear CPU (CPU1) uses heatsink UCSC-HS2-C125. The front CPU (CPU2) uses heatsink UCSC-HS-C125.

- Align the heatsink over the CPU socket. Align the triangle-mark on the heatsink with the triangle-mark on the socket frame, as shown in the following figure.

Figure 10: Heatsink Alignment Marks

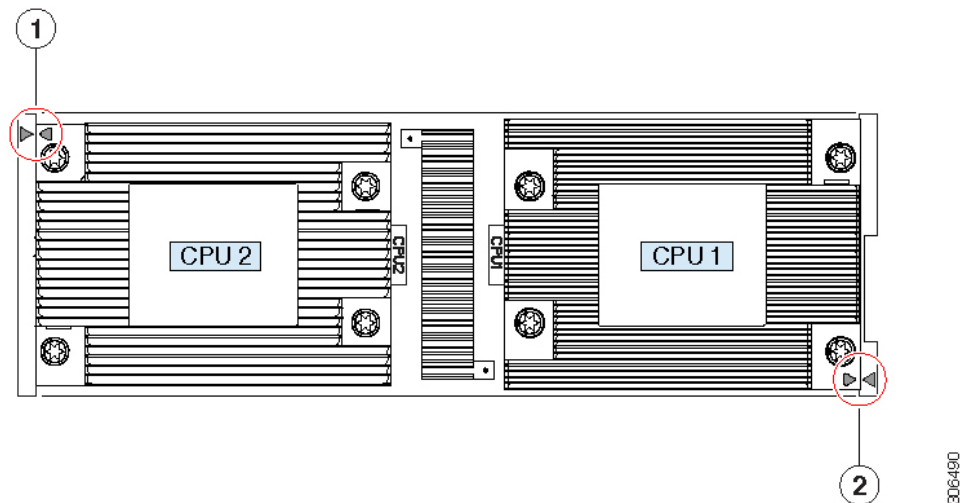

<b>1</b>	Triangle marks on front heatsink UCSC-HS-C125 and CPU 2 socket.	<b>2</b>	Triangle marks on rear heatsink UCSC-HS2-C125 and CPU 1 socket.
----------	---	----------	---

- b) Use a T-20 Torx driver to tighten the four captive screws that secure the heatsink.

**Caution** Alternate tightening the heatsink screws evenly so that the heatsink remains level while it is lowered. Tighten the heatsink screws in the order shown on the heatsink label (1, 2, 3, 4).

**Step 9** Return the node to the chassis:

- a) With the ejector lever fully open, align the new node with the empty bay.
- b) Push the server node into the bay until it engages with the midplane connectors and is flush with the chassis.
- c) Rotate the ejector lever toward the center until it lays flat.
- d) Tighten the thumbscrew on the ejector lever to secure the node in the chassis bay.

**Step 10** Reconnect any cables that you removed.

**Step 11** Power on the server node.

## Additional CPU-Related Parts to Order with RMA Replacement CPUs or RMA Nodes

When a return material authorization (RMA) of the CPU is done on a node, additional parts might not be included with the CPU spare. The TAC engineer might need to add the additional parts to the RMA to help ensure a successful replacement.

- Scenario 1—You are reusing the existing heatsinks or moving CPUs and heatsinks to a new node:
  - Heatsink cleaning kit (UCSX-HSCK=)
    - One cleaning kit can clean up to four CPUs.
  - Thermal interface material (TIM) kit (UCS-CPU-TIM=)

One TIM kit covers one CPU.

- Scenario 2—You are replacing the existing heatsinks:



---

**Caution** Use only the correct heatsink for your CPUs to ensure proper cooling. The front and rear CPUs use different heatsinks. The rear CPU (CPU1) uses UCSC-HS2-C125. The front CPU (CPU2) uses heatsink UCSC-HS-C125.

---

- Heatsink: UCSC-HS-C125= or UCSC-HS2-C125=  
New heatsinks have a pre-applied pad of TIM.
- Heatsink cleaning kit (UCSX-HSCK=)  
One cleaning kit can clean up to four CPUs.

A CPU heatsink cleaning kit is good for up to four CPU and heatsink cleanings. The cleaning kit contains two bottles of solution, one to clean the CPU and heatsink of old TIM and the other to prepare the surface of the heatsink.

New heatsink spares come with a pre-applied pad of TIM. It is important to clean any old TIM off of the CPU surface prior to installing the heatsinks. Therefore, even when you are ordering new heatsinks, you must order the heatsink cleaning kit.

## Installing and Enabling a TPM

The trusted platform module (TPM) is a small circuit board that plugs into a node board socket and is then permanently secured with a one-way screw.



---

**Note** Field replacement of a TPM is not supported; you can install a TPM after-factory only if the server does not already have a TPM installed.

---

This topic contains the following procedures, which must be followed in this order when installing and enabling a TPM:

1. Installing the TPM Hardware
2. Enabling the TPM in the BIOS

## TPM Considerations

- This server supports TPM version 2.0. The TPM 2.0, UCSX-TPM2-002B(=), is compliant with Federal Information Processing (FIPS) Standard 140-2. FIPS support has existed, but FIPS 140-2 is now supported.
- Field *replacement* of a TPM is not supported; you can install a TPM after-factory only if the server does not already have a TPM installed.
- If the TPM 2.0 becomes unresponsive, reboot the server.

## Installing TPM Hardware



---

**Caution** Always shut down the node before removing it from the chassis, as described in the procedures. Failure to shut down the node before removal results in the corresponding RAID supercap cache being discarded and other data might be lost.

---



---

**Note** For security purposes, the TPM is installed with a one-way screw. It cannot be removed with a standard screwdriver.

---

- 
- Step 1** Shut down the server node by using the software interface or by pressing the node power button, as described in [Shutting Down and Removing Power From a Node, on page 7](#).
- Step 2** Disconnect any cables from ports on the node or installed cards.
- Step 3** Remove the node from the system:
- Loosen the captive thumbscrew on the ejector lever of the node.
  - Rotate the ejector lever to the outside to evenly disengage the node from its midplane connectors.
  - Pull the node straight out from the system.
- Step 4** Install a TPM:
- Locate the TPM socket on the server node, as shown below.
  - Align the connector that is on the bottom of the TPM circuit board with the node board TPM socket. Align the screw hole on the TPM board with the screw hole that is adjacent to the TPM socket.
  - Push down evenly on the TPM to seat it in the socket.
  - Install the single one-way screw that secures the TPM to the board.
- Step 5** Return the node to the chassis:
- With the ejector lever fully open, align the new node with the empty bay.
  - Push the server node into the bay until it engages with the midplane connectors and is flush with the chassis.
  - Rotate the ejector lever toward the center until it lays flat.
  - Tighten the thumbscrew on the ejector lever to secure the node in the chassis bay.
- Step 6** Reconnect any cables that you removed.
- Step 7** Power on the server node.

Figure 11: Location of the TPM Socket

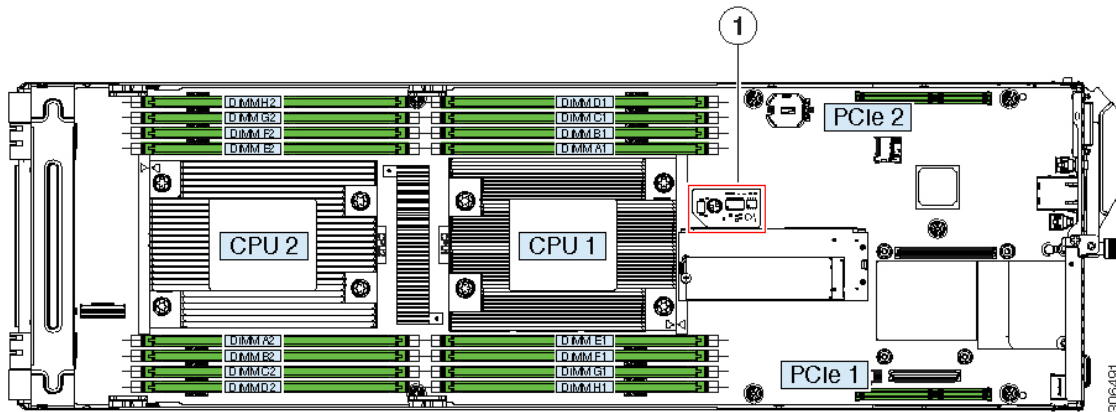

1	TPM location on server node	-	
---	-----------------------------	---	--

**Step 8** Continue with [Enabling the TPM in the BIOS, on page 27](#).

## Enabling the TPM in the BIOS

After hardware installation, you must enable TPM support in the BIOS.



**Note** You must set a BIOS Administrator password before performing this procedure. To set this password, press the **F2** key when prompted during system boot to enter the BIOS Setup utility. Then navigate to **Advanced > Security > Set Administrator Password** and enter the new password twice as prompted.

**Step 1** Enable TPM Support:

- a) Watch during bootup for the F2 prompt, and then press **F2** to enter BIOS setup.
- b) Log in to the BIOS Setup Utility with your BIOS Administrator password.
- c) On the BIOS Setup Utility window, choose the **Advanced** tab.
- d) Choose **Trusted Computing** to open the TPM Security Device Configuration window.
- e) Change TPM SUPPORT to **Enabled**.
- f) Press **F10** to save your settings and reboot the server.

**Step 2** Verify that TPM support is now enabled:

- a) Watch during bootup for the F2 prompt, and then press **F2** to enter BIOS setup.
- b) Log into the BIOS Setup utility with your BIOS Administrator password.
- c) Choose the **Advanced** tab.
- d) Choose **Trusted Computing** to open the TPM Security Device Configuration window.
- e) Verify that TPM SUPPORT and TPM State are Enabled.

# Replacing the RTC Battery

The real-time clock (RTC) battery retains system settings when the node is disconnected from power. The battery type is CR2032. Cisco supports the industry-standard CR2032 battery, which can be purchased from most electronic stores.



---

**Note** Always shut down the node before removing it from the chassis, as described in the procedures. Failure to shut down the node before removal results in the corresponding RAID supercap cache being discarded and other data might be lost.

---



---

**Note** When the RTC battery is removed or it completely loses power, settings that were stored in the BMC of the server node are lost. You must reconfigure the BMC settings after installing a new battery.

---



---

**Caution** Removing the RTC battery impacts the following:

- Real clock time gets reset to default value.
- CMOS setting of the server is lost. You should reset the system setting after replacing the RTC battery.

---



---

**Warning** **Recyclers:** Do not shred the battery! Make sure you dispose of the battery according to appropriate regulations for your country or locale.

---

- 
- Step 1** Shut down the node by using the software interface or by pressing the node power button, as described in [Shutting Down and Removing Power From a Node, on page 7](#).
- Step 2** Disconnect any cables from ports on the node or installed cards.
- Step 3** Remove the node from the system:
- Loosen the captive thumbscrew on the ejector lever of the node.
  - Rotate the ejector lever to the outside to evenly disengage the node from its midplane connectors.
  - Pull the node straight out from the system.
- Step 4** Remove both PCIe risers from the node to provide clearance to the RTC battery socket. See [Replacing a PCIe Riser, on page 41](#).
- Step 5** Remove the node RTC battery:
- Locate the RTC battery in its horizontal socket.

Figure 12: RTC Battery Socket Location

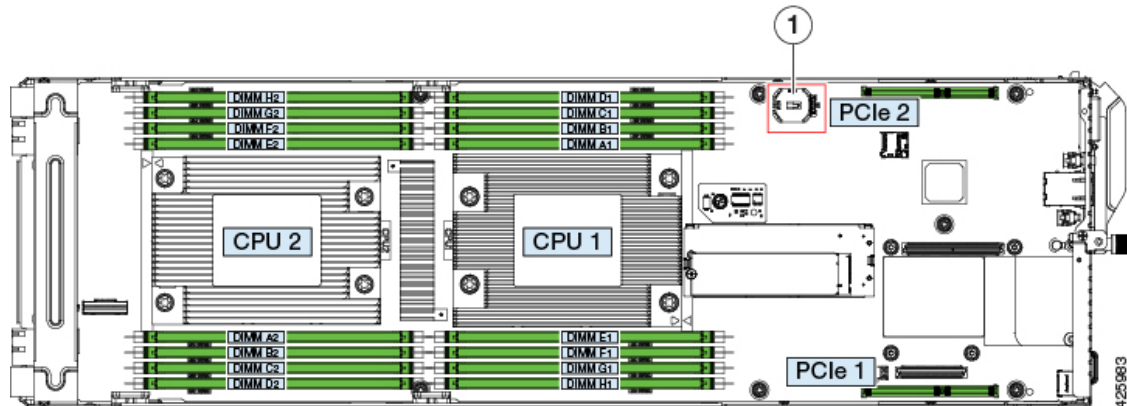

1	RTC battery horizontal socket	-	
---	-------------------------------	---	--

b) Gently pry the battery from the socket.

**Step 6**

Install a new RTC battery:

a) Set the battery in the socket.

**Note** The flat, positive side of the battery marked “+” should face up.

b) Push the battery into the socket until it is fully seated and the retaining clips click over the top of the battery.

**Step 7**

Reinstall both PCIe risers to the node using the procedure in [Replacing a PCIe Riser, on page 41](#).

**Step 8**

Return the node to the chassis:

a) With the ejector lever fully open, align the new node with the empty bay.

b) Push the server node into the bay until it engages with the midplane connectors and is flush with the chassis.

c) Rotate the ejector lever toward the center until it lays flat.

d) Tighten the thumbscrew on the ejector lever to secure the node in the chassis bay.

**Step 9**

Reconnect any cables that you removed.

**Step 10**

Power on the node.

**Step 11**

Reconfigure the BMC settings for this node.

## Replacing a Mini-Storage Module

The mini-storage module plugs into a board socket to provide additional internal storage. The mini-storage module is available in two different versions:

- SD card carrier—provides two SD card sockets.
- M.2 SSD carrier—provides two M.2 form-factor SSD sockets.
- M.2 boot-optimized RAID controller—provides slots for two SATA M.2 drives, plus an integrated 6-Gbps SATA RAID controller.



---

**Note** The Cisco IMC firmware does not include an out-of-band management interface for the M.2 drives installed in the M.2 version of this mini-storage module (UCS-MSTOR-M2). The M.2 drives are not listed in Cisco IMC inventory, nor can they be managed by Cisco IMC. This is expected behavior.

---

## Replacing a Mini-Storage Module Carrier

This topic describes how to remove and replace a mini-storage module carrier. The carrier has one media socket on its top and one socket on its underside. Use the following procedure for any type of mini-storage module carrier (SD card or M.2 SSD).



---

**Caution** Always shut down the node before removing it from the chassis, as described in the procedures. Failure to shut down the node before removal results in the corresponding RAID supercap cache being discarded and other data might be lost.

---

- 
- Step 1** Shut down the node by using the software interface or by pressing the node power button, as described in [Shutting Down and Removing Power From a Node, on page 7](#).
- Step 2** Disconnect any cables from ports on the node or installed cards.
- Step 3** Remove the node from the system:
- Loosen the captive thumbscrew on the ejector lever of the node.
  - Rotate the ejector lever to the outside to evenly disengage the node from its midplane connectors.
  - Pull the node straight out from the system.
- Step 4** If you have a card installed in PCIe riser 1, you must remove the riser to provide access, as described in [Replacing a PCIe Riser, on page 41](#). Remove riser 1 and continue with the next step.
- Step 5** Remove a carrier from its socket:
- Locate the mini-storage module carrier in the node as shown below.
  - Push outward on the securing clips that holds each end of the carrier.
  - Lift both ends of the carrier to disengage it from the socket on the board.
  - Set the carrier on an anti-static surface.
- Step 6** Install a new carrier to its socket:
- Position the carrier over the socket, with the carrier's connector facing down and at the same end as the board socket. Two alignment pegs must match with two holes on the carrier.
  - Set the end of the carrier opposite the socket under the clip on that end.
  - Gently push down the socket end of the carrier so that the two pegs go through the two holes on the carrier.
  - Push down on the carrier so that the securing clips click over it at both ends.



Figure 13: Mini-Storage Module Carrier

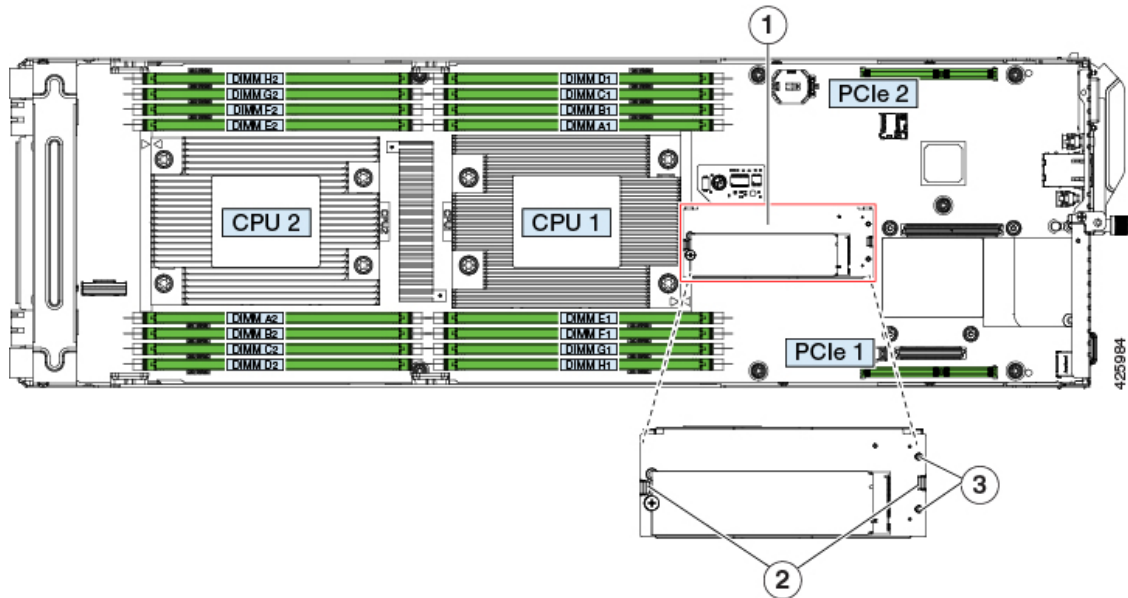

1	Location of socket on board	3	Alignment pegs that pass through holes in the carrier
2	Securing clips at each end of carrier	-	

- Step 7** If you removed PCIe riser 1 to provide clearance, reinstall the riser as described in [Replacing a PCIe Riser, on page 41](#).
- Step 8** Return the node to the chassis:
- With the ejector lever fully open, align the new node with the empty bay.
  - Push the server node into the bay until it engages with the midplane connectors and is flush with the chassis.
  - Rotate the ejector lever toward the center until it lays flat.
  - Tighten the thumbscrew on the ejector lever to secure the node in the chassis bay.
- Step 9** Reconnect any cables that you removed.
- Step 10** Power on the node.

## Replacing an SD Card in a Mini-Storage Carrier For SD

This topic describes how to remove and replace an SD card in a mini-storage carrier for SD (UCS-MSTOR-SD). The carrier has one SD card socket on its top and one socket on its underside.

### Population Rules For Mini-Storage SD Cards

- You can use one or two SD cards in the carrier.
- Dual SD cards can be configured in a RAID 1 array through the Cisco IMC interface.
- SD socket 1 is on the top side of the carrier; SD socket 2 is on the underside of the carrier (the same side as the carrier's motherboard connector).

- 
- Step 1** Shut down the node, remove it from the chassis, and then remove the mini-storage module carrier from the node as described in [Replacing a Mini-Storage Module Carrier, on page 30](#).
- Step 2** Remove an SD card:
- Push on the top of the SD card, and then release it to allow it to spring out from the socket.
  - Grasp and remove the SD card from the socket.
- Step 3** Install a new SD card:
- Insert the new SD card into the socket with its label side facing up (away from the carrier).
  - Press on the top of the SD card until it clicks in the socket and stays in place.
- Step 4** Install the mini-storage module carrier back into the node and then reinstall the node to the chassis as described in [Replacing a Mini-Storage Module Carrier, on page 30](#).
- Step 5** Power on the node.
- 

## Replacing an M.2 SSD in a Mini-Storage Carrier For M.2

This topic describes how to remove and replace an M.2 SATA or in a mini-storage carrier for M.2 (UCS-MSTOR-M2). The carrier has one M.2 SSD socket on its top and one socket on its underside.

### Population Rules For Mini-Storage M.2 SSDs

- You can use one or two M.2 SSDs in the carrier.
  - M.2 slot 1 is on the top side of the carrier; M.2 slot 2 is on the underside of the carrier (the same side as the carrier's motherboard connector).
- 

- Step 1** Shut down the node, remove it from the chassis, and then remove the mini-storage module carrier from the node as described in [Replacing a Mini-Storage Module Carrier, on page 30](#).
- Step 2** Remove an M.2 SSD:
- Use a #1 Phillips-head screwdriver to remove the single screw that secures the M.2 SSD to the carrier.
  - Grasp the M.2 SSD and lift up on the end that is opposite its socket on the carrier.
  - Remove the M.2 SSD from its socket on the carrier.
- Step 3** Install a new M.2 SSD:
- Angle downward and insert the new M.2 SSD connector-end into the socket on the carrier with its label side facing up.
  - Press the M.2 SSD flat against the carrier.
  - Install the single screw that secures the end of the M.2 SSD to the carrier.
- Step 4** Install the mini-storage module carrier back into the node and then reinstall the node to the chassis as described in [Replacing a Mini-Storage Module Carrier, on page 30](#).
- Step 5** Power on the node.
-

## Replacing a Boot-Optimized M.2 RAID Controller Module

The Cisco Boot-Optimized M.2 RAID Controller module connects to the mini-storage module socket on the motherboard. It includes slots for two SATA M.2 drives, plus an integrated 6-Gbps SATA RAID controller that can control the SATA M.2 drives in a RAID 1 array.

- [Cisco Boot-Optimized M.2 RAID Controller Considerations, on page 33](#)
- [Replacing a Cisco Boot-Optimized M.2 RAID Controller Module, on page 34](#)

### Cisco Boot-Optimized M.2 RAID Controller Considerations

Review the following considerations for the Cisco boot-optimized M.2 RAID controller:



**Note** The Cisco Boot-Optimized M.2 RAID Controller is not supported when the server is used as a compute-only node in Cisco HyperFlex configurations.

- The minimum version of Cisco IMC and Cisco UCS Manager that support this controller is 4.1(2a).
- This controller supports RAID 1 (single volume) and JBOD mode.



**Note** Do not use the server's embedded SW MegaRAID controller to configure RAID settings when using this controller module. Instead, you can use the following interfaces:

- Cisco IMC 4.1(2a) and later
  - BIOS HII utility, BIOS 4.0(4a) and later for Intel platforms
  - BIOS 4.1.X and later for AMD platforms
  - Cisco UCS Manager 4.1(2a) and later (UCS Manager-integrated servers)
- 
- A SATA M.2 drive in slot 1 (the top) is the first SATA device; a SATA M.2 drive in slot 2 (the underside) is the second SATA device.
    - The name of the controller in the software is MSTOR-RAID.
    - A drive in Slot 1 is mapped as drive 253; a drive in slot 2 is mapped as drive 254.
  - When using RAID, we recommend that both SATA M.2 drives are the same capacity. If different capacities are used, the smaller capacity of the two drives is used to create a volume and the rest of the drive space is unusable.

JBOD mode supports mixed capacity SATA M.2 drives.
  - Hot-plug replacement is *not* supported. The server must be powered off.
  - Monitoring of the controller and installed SATA M.2 drives can be done using Cisco IMC and Cisco UCS Manager. They can also be monitored using other utilities such as UEFI HII, PMCLI, XMLAPI, and Redfish.

- Updating firmware of the controller and the individual drives:
  - For standalone servers, use the Cisco Host Upgrade Utility (HUU). Refer to the [HUU Documentation](#).
  - For servers integrated with Cisco UCS Manager, refer to the [Cisco UCS Manager Firmware Management Guide](#).
- The SATA M.2 drives can boot in UEFI mode only. Legacy boot mode is not supported.
- If you replace a single SATA M.2 drive that was part of a RAID volume, rebuild of the volume is auto-initiated after the user accepts the prompt to import the configuration. If you replace both drives of a volume, you must create a RAID volume and manually reinstall any OS.
- We recommend that you erase drive contents before creating volumes on used drives from another server. The configuration utility in the server BIOS includes a SATA secure-erase function.
- The server BIOS includes a configuration utility specific to this controller that you can use to create and delete RAID volumes, view controller properties, and erase the physical drive contents. Access the utility by pressing **F2** when prompted during server boot. Then navigate to **Advanced > Cisco Boot Optimized M.2 RAID Controller**.

## Replacing a Cisco Boot-Optimized M.2 RAID Controller Module

This topic describes how to remove and replace a Cisco Boot-Optimized M.2 RAID Controller. The controller board has one M.2 socket on its top (Slot 1) and one M.2 socket on its underside (Slot 2).

- 
- Step 1** Shut down and remove power from the server node as described in [Shutting Down and Removing Power From a Node, on page 7](#).
- Step 2** Remove the compute node out from the server. You might have to detach cables to provide clearance.
- Step 3** Remove a controller from its motherboard socket:
- a) Locate the controller in its socket just in front of CPU 1.
  - b) At each end of the controller board, push outward on the clip that secures the carrier.
  - c) Lift both ends of the controller to disengage it from the socket on the motherboard.
  - d) Set the carrier on an anti-static surface.
- Step 4** If you are transferring SATA M.2 drives from the old controller to the replacement controller, do that before installing the replacement controller:
- Note** Any previously configured volume and data on the drives are preserved when the M.2 drives are transferred to the new controller. The system will boot the existing OS that is installed on the drives.
- a) Use a #1 Phillips-head screwdriver to remove the single screw that secures the M.2 drive to the carrier.

Figure 14: Cisco Boot-Optimized M.2 RAID Controller on Motherboard

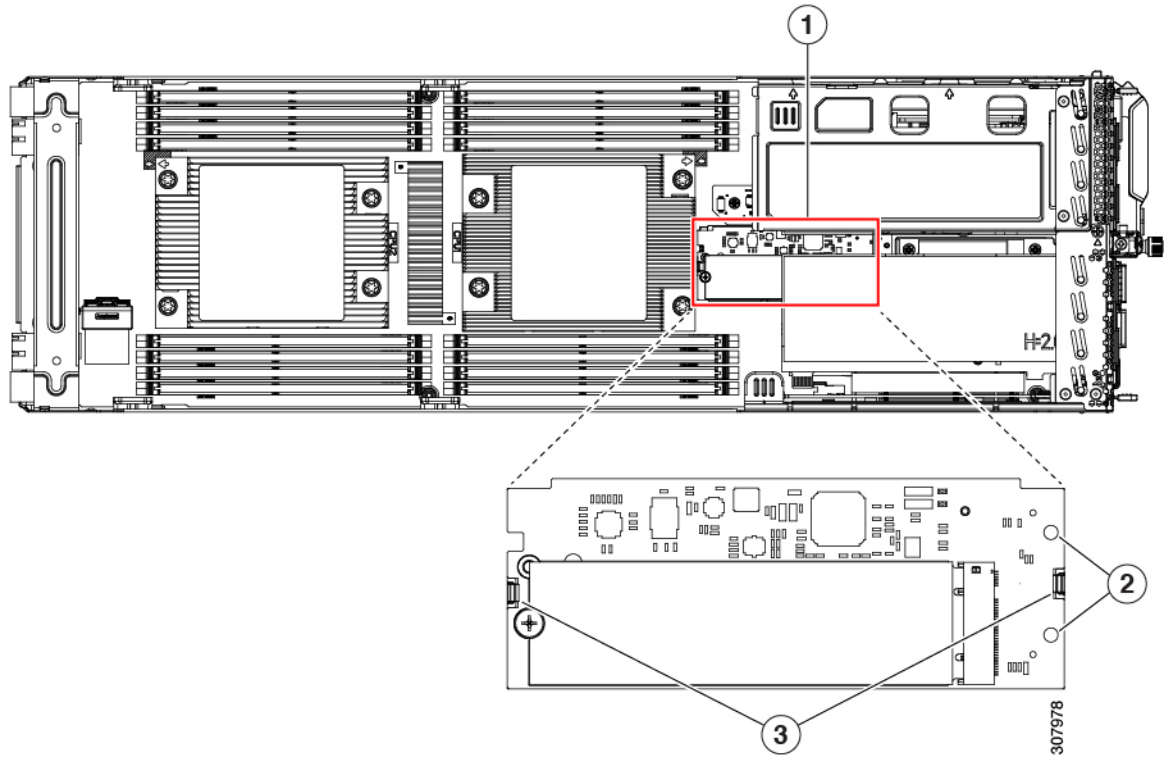

<b>1</b>	Location of socket on motherboard	<b>2</b>	Alignment pegs
<b>3</b>	Securing clips	-	

- b) Lift the M.2 drive from its socket on the carrier.
- c) Position the replacement M.2 drive over the socket on the controller board.
- d) Angle the M.2 drive downward and insert the connector-end into the socket on the carrier. The M.2 drive's label must face up.
- e) Press the M.2 drive flat against the carrier.
- f) Install the single screw that secures the end of the M.2 SSD to the carrier.
- g) Turn the controller over and install the second M.2 drive.

Figure 15: Cisco Boot-Optimized M.2 RAID Controller, Showing M.2 Drive Installation

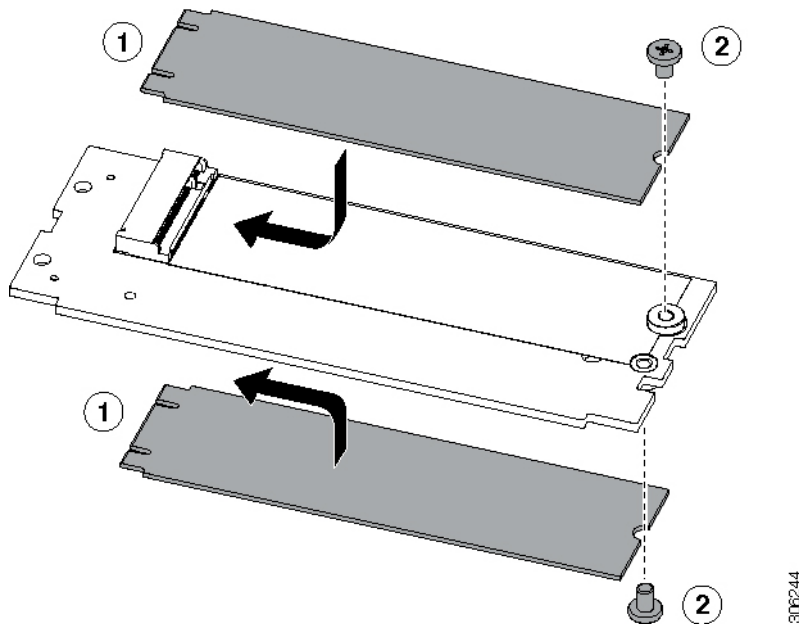

**Step 5** Install the controller to its socket on the motherboard:

- Position the controller over the socket, with the controller's connector facing down and at the same end as the motherboard socket. Two alignment pegs must match with two holes on the controller.
- Gently push down the socket end of the controller so that the two pegs go through the two holes on the controller.
- Gently push down the socket end of the controller so that the two pegs go through the two holes on the controller.

**Step 6** Replace the node in the server, replace cables, and then fully power on the server by pressing the Power button.

## Replacing a Micro SD Card

There is one socket for a Micro SD card on the node board.



**Caution** Always shut down the node before removing it from the chassis, as described in the procedures. Failure to shut down the node before removal results in the corresponding RAID supercap cache being discarded and other data might be lost.

**Step 1** Shut down the node by using the software interface or by pressing the node power button, as described in [Shutting Down and Removing Power From a Node, on page 7](#).

**Step 2** Disconnect any cables from ports on the node or installed cards.

**Step 3** Remove the node from the system:

- Loosen the captive thumbscrew on the ejector lever of the node.
- Rotate the ejector lever to the outside to evenly disengage the node from its midplane connectors.

c) Pull the node straight out from the system.

**Step 4** Remove both PCIe risers from the node to provide clearance to the Micro-SD card socket, as described in [Replacing a PCIe Riser, on page 41](#).

**Step 5** Remove an existing Micro SD card:

- a) Locate the Micro SD card, as shown below.
- b) Push horizontally on the Micro SD card and release it to make it spring out from the socket.
- c) Grasp the Micro SD card and lift it from the socket.

**Step 6** Install a new Micro SD card:

- a) Align the new Micro SD card with the horizontal socket.
- b) Gently push horizontally on the card until it clicks and locks in place in the socket.

**Figure 16: Micro SD Card Location**

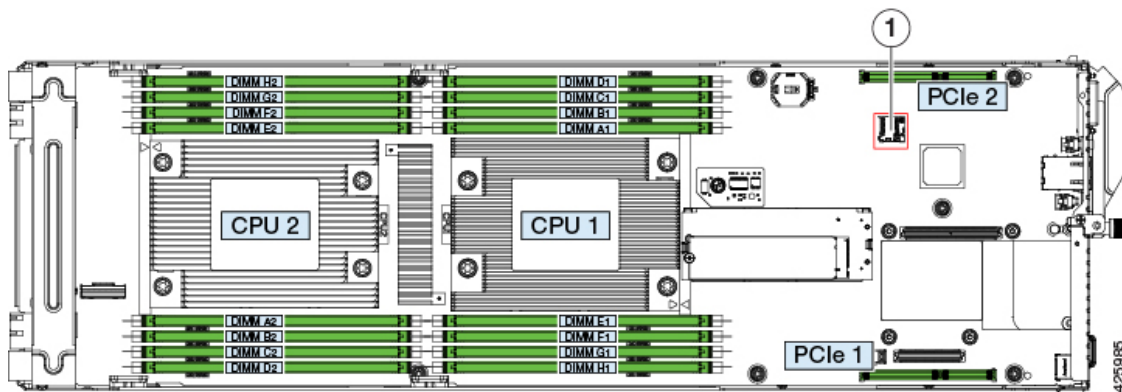

1	Location of Micro SD card socket	-	
---	----------------------------------	---	--

**Step 7** Reinstall both PCIe risers to the node using the procedure in [Replacing a PCIe Riser, on page 41](#).

**Step 8** Return the node to the chassis:

- a) With the ejector lever fully open, align the new node with the empty bay.
- b) Push the server node into the bay until it engages with the midplane connectors and is flush with the chassis.
- c) Rotate the ejector lever toward the center until it lays flat.
- d) Tighten the thumbscrew on the ejector lever to secure the node in the chassis bay.

**Step 9** Reconnect any cables that you removed.

**Step 10** Power on the node.

# Replacing a PCIe Card



**Note** Cisco supports all PCIe cards qualified and sold by Cisco. PCIe cards not qualified or sold by Cisco are the responsibility of the customer. Although Cisco will always stand behind and support the C-Series rack-mount servers, customers using standard, off-the-shelf, third-party cards must go to the third-party card vendor for support if any issue with that particular card occurs.

## PCIe Slot Specifications

The node contains two PCIe risers for horizontal installation of PCIe cards. Both slots support 12V standby power.

Figure 17: PCIe Slot Numbering

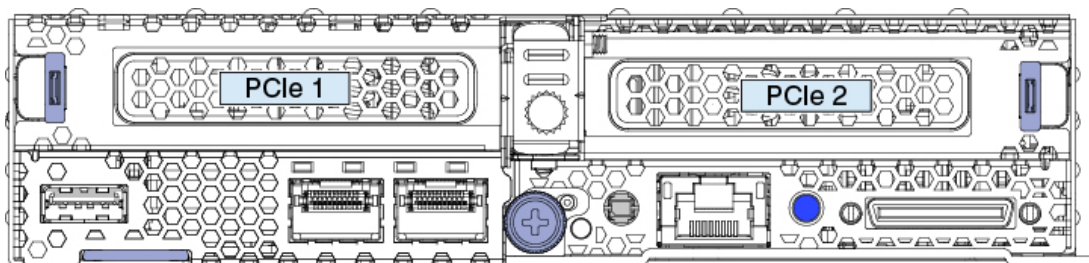

The following tables describe the specifications for the slots.

Table 7: PCIe Riser 1 (UCSC-PCI1A-C125) PCIe Expansion Slot

PCIe Slot Number	Electrical Lane Width	Connector Length	Maximum Card Length	Card Height (Rear Panel Opening)	NCSI Support
1	Gen-3 x8	x16 connector	1/2 length	1/2 height	No
Slimline connector for optional, internal SATA cable	Gen-3 x8	Slimline	NA	NA	No

Table 8: PCIe Riser 2 (UCSC-PCI2-C125) PCIe Expansion Slot

PCIe Slot Number	Electrical Lane Width	Connector Length	Maximum Card Length	Card Height (Rear Panel Opening)	NCSI Support
2	Gen-3 x16	x16 connector	1/2 length	1/2 height	Yes

## Replacing a PCIe Card

This node has two PCIe risers for horizontal installation of up to two PCIe cards.



See [PCIe Slot Specifications, on page 38](#) for detailed descriptions of the slots and features in each riser.

If the card that you are replacing is a RAID controller card, see [Replacing a Storage Controller Card, on page 43](#).



---

**Caution** Always shut down the node before removing it from the chassis, as described in the procedures. Failure to shut down the node before removal results in the corresponding RAID supercap cache being discarded and other data might be lost.

---

**Step 1** Shut down the node by using the software interface or by pressing the node power button, as described in [Shutting Down and Removing Power From a Node, on page 7](#).

**Step 2** Disconnect any cables from ports on the node or installed cards.

**Step 3** Remove the node from the system:

- a) Loosen the captive thumbscrew on the ejector lever of the node.
- b) Rotate the ejector lever to the outside to evenly disengage the node from its midplane connectors.
- c) Pull the node straight out from the system.

**Step 4** Remove the PCIe riser where you will replace or install a PCIe card:

**Note** If you remove riser 2, you must also remove riser 1 first because riser 1 sits on top of riser 2 where they share a common screw. You can remove riser 1 without removing riser 2.

- a) Depending on which riser you are replacing, do one of the following:
  - If you are removing only riser 1, use a #2 Phillips screwdriver and remove three screws (see the figure below).
  - If you are removing riser 2, use a #2 Phillips screwdriver to loosen the one captive screw and remove the five screws that secure riser 1 and riser 2 (see the figure below).
- b) Depending on which riser you are replacing, do one of the following:
  - If you are removing riser 1, grasp the two gripping points on the riser and lift it straight up from the socket on the board (see the blue gripping points in the following figure).
  - If you are removing riser 2, first remove riser 1. Then grasp the two gripping points on riser 2 and lift it straight up from the socket on the board (see the blue gripping points in the following figure).

Figure 18: PCIe Risers

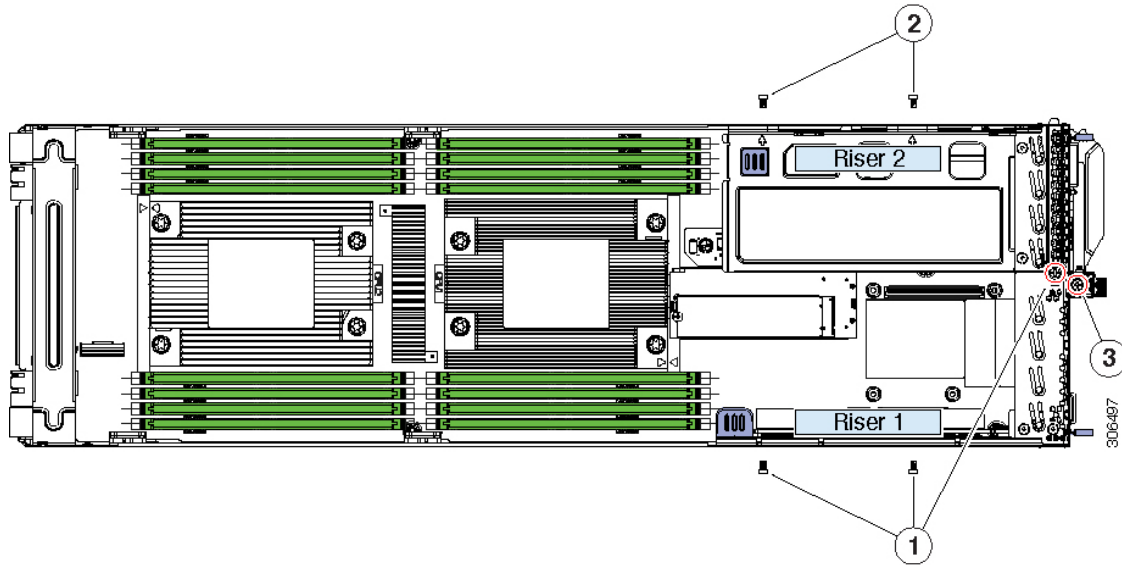

<p><b>1</b></p>	<p>Three securing screws for riser 1 When removing riser 1, remove these three screws and then loosen the captive screw.</p>	<p><b>3</b></p>	<p>Captive screw</p>
<p><b>2</b></p>	<p>Two external securing screws for riser 2 When removing riser 2, remove the three screws for riser 1, then remove these two screws, and then loosen the captive screw.</p>	<p>-</p>	

**Step 5** Remove any existing card that you are replacing. Grasp the card and pull it horizontally from the socket on the riser.

**Step 6** Install a new card:

- a) Align the card's edge connector with the socket on the riser while you align the card's rear panel tab with the opening in the riser.
- b) Gently push on both ends of the card to seat it in the socket. The card's rear panel tab must be even with the rear panel of the riser.

**Step 7** Install the PCIe riser:

- a) Position the PCIe riser over its socket on the node board.

**Note** If you removed riser 1 and 2, you must install riser 2 before you install riser 1.

- b) Carefully push down on both ends of the PCIe riser to fully engage its connector with the socket on the board.
- c) Install and tighten the screws that you removed.

**Step 8** Return the node to the chassis:

- a) With the node ejector lever fully open, align the new node with the empty bay.
- b) Push the server node into the bay until it engages with the midplane connectors and is flush with the chassis.
- c) Rotate the ejector lever toward the center until it lays flat.
- d) Tighten the thumbscrew on the ejector lever to secure the node in the chassis bay.

**Step 9** Reconnect any cables that you removed.

**Step 10** Power on the node.

## Cisco Virtual Interface Card (VIC) Considerations

This section describes VIC card support and special considerations for this node.

If you want to use the Cisco UCS VIC card for Cisco UCS Manager integration, see also the [Cisco UCS C-Series Server Integration with Cisco UCS Manager Guides](#) for details about supported configurations, cabling, and other requirements.



**Note** Only PCIe 2 supports the NCSI protocol, which is required for integration with Cisco UCS Manager or Cisco Card NIC mode.

**Table 9: VIC Support and Considerations in This Node**

VIC	How Many Supported in Node	Slots That Support VICs	Slot For Cisco UCS Manager Integration	Slot For <i>Cisco Card</i> NIC Mode	Minimum Cisco IMC Firmware
Cisco UCS VIC 1455 UCSC-PCIE-C25Q-04	1	PCIe 2	PCIe 2	PCIe 2	4.0(1)
Cisco UCS VIC 1495 UCSC-PCIE-C100Q-04	1	PCIe 2	PCIe 2	PCIe 2	4.0(2)

## Replacing a PCIe Riser

This node has two PCIe risers for horizontal installation of up to two PCIe cards.

See [PCIe Slot Specifications, on page 38](#) for detailed descriptions of the slots and features in each riser.



**Caution** Always shut down the node before removing it from the chassis, as described in the procedures. Failure to shut down the node before removal results in the corresponding RAID supercap cache being discarded and other data might be lost.

**Step 1** Shut down the node by using the software interface or by pressing the node power button, as described in [Shutting Down and Removing Power From a Node, on page 7](#).

**Step 2** Disconnect any cables from ports on the node or installed cards.

**Step 3** Remove the node from the system:

- a) Loosen the captive thumbscrew on the ejector lever of the node.

- b) Rotate the ejector lever to the outside to evenly disengage the node from its midplane connectors.
- c) Pull the node straight out from the system.

**Step 4** Remove the PCIe riser:

**Note** If you remove riser 2, you must also remove riser 1 first because riser 1 sits on top of riser 2 where they share common screws. You can remove riser 1 without removing riser 2.

- a) Depending on which riser you are replacing, do one of the following:
  - If you are removing only riser 1, use a #2 Phillips screwdriver to remove three screws (see the figure below).
  - If you are removing riser 2, use a #2 Phillips screwdriver to loosen one captive screw and remove five screws (see the figure below).
- b) Depending on which riser you are replacing, do one of the following:
  - If you are removing riser 1, grasp the two gripping points on the riser and lift it straight up from the socket on the board (see the blue gripping points in the following figure).
  - If you are removing riser 2, first remove riser 1. Then grasp the two gripping points on the riser and lift it straight up from the socket on the board (see the blue gripping points in the following figure).
- c) If the riser that you are replacing has a card installed, remove the card from the riser. See [Replacing a PCIe Card, on page 38](#) or [Replacing a Storage Controller Card, on page 43](#).

**Step 5** Install a new PCIe riser:

- a) If you removed a card from the old PCIe riser, install the card to the new riser.
- b) Position the PCIe riser over its socket on the node board.

**Note** If you removed riser 1 and 2, you must install riser 2 before you install riser 1.

- c) Carefully push down on both ends of the PCIe riser to fully engage its connector with the socket on the board.
- d) Install and tighten the screws that you removed.

**Step 6** Return the node to the chassis:

- a) With the node ejector lever fully open, align the new node with the empty bay.
- b) Push the server node into the bay until it engages with the midplane connectors and is flush with the chassis.
- c) Rotate the ejector lever toward the center until it lays flat.
- d) Tighten the thumbscrew on the ejector lever to secure the node in the chassis bay.

**Step 7** Reconnect any cables that you removed.**Step 8** Power on the node.

Figure 19: PCIe Risers

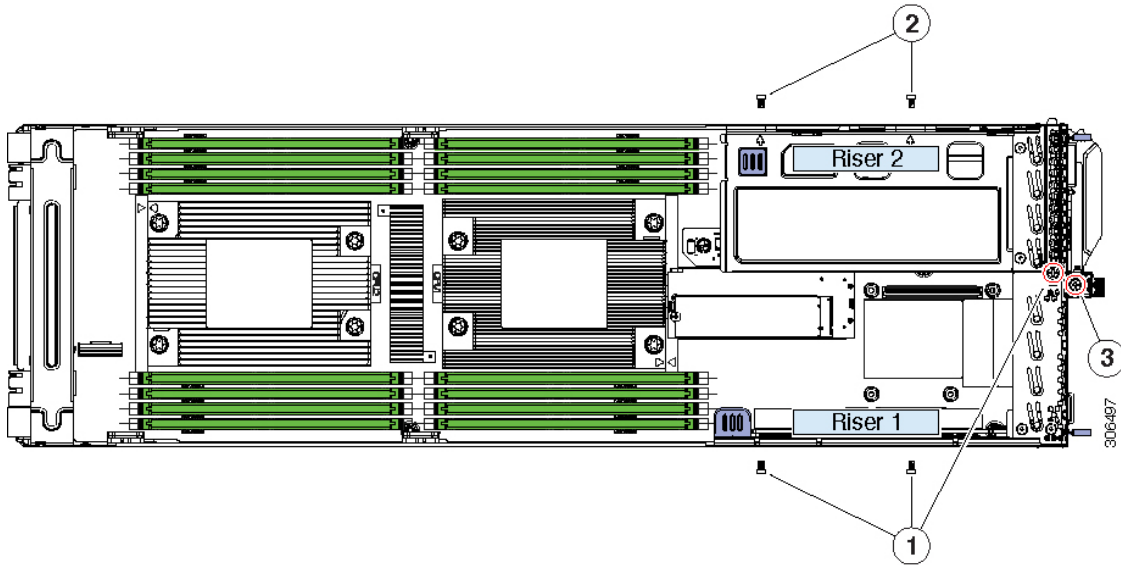

<p><b>1</b></p>	<p>Three securing screws for riser 1 When removing riser 1, remove these three screws and then loosen the captive screw.</p>	<p><b>3</b></p>	<p>Captive screw</p>
<p><b>2</b></p>	<p>Two external securing screws for riser 2 When removing riser 2, remove the three screws for riser 1, then remove these two screws, and then loosen the captive screw.</p>	<p>-</p>	

## Replacing a Storage Controller Card

Each node in the system supports one RAID controller card in PCIe riser 1/slot 1. For SAS control of drives, you connect a SAS cable to the controller card.

For component replacement, the controller card, supercap, SAS cable, and supercap cable are orderable separately. If you are installing a RAID controller card to the node for the first time, you can order the card, supercap, SAS cable, and supercap cable as kit UCSC-RAID-C125-KIT.

For information about storage controllers supported by this node, see [Supported Storage Controllers and Cables, on page 53](#).



**Caution**

Always shut down the node before removing it from the chassis, as described in the procedures. Failure to shut down the node before removal results in the corresponding RAID supercap cache being discarded and other data might be lost.

**Step 1** Shut down the node by using the software interface or by pressing the node power button, as described in [Shutting Down and Removing Power From a Node, on page 7](#).

**Step 2** Disconnect any cables from ports on the node or installed cards.

**Step 3** Remove the node from the system:

- a) Loosen the captive thumbscrew on the ejector lever of the node.
- b) Rotate the ejector lever to the outside to evenly disengage the node from its midplane connectors.
- c) Pull the node straight out from the system.

**Step 4** Remove PCIe riser 1:

- a) Use a #2 Phillips screwdriver to loosen one captive screw and remove three screws (see the figure below).
- b) Grasp the two gripping points on the riser and lift it straight up from the socket on the board (see the blue gripping points in the following figure).
- c) Set the riser upside-down.

**Figure 20: PCIe Risers**

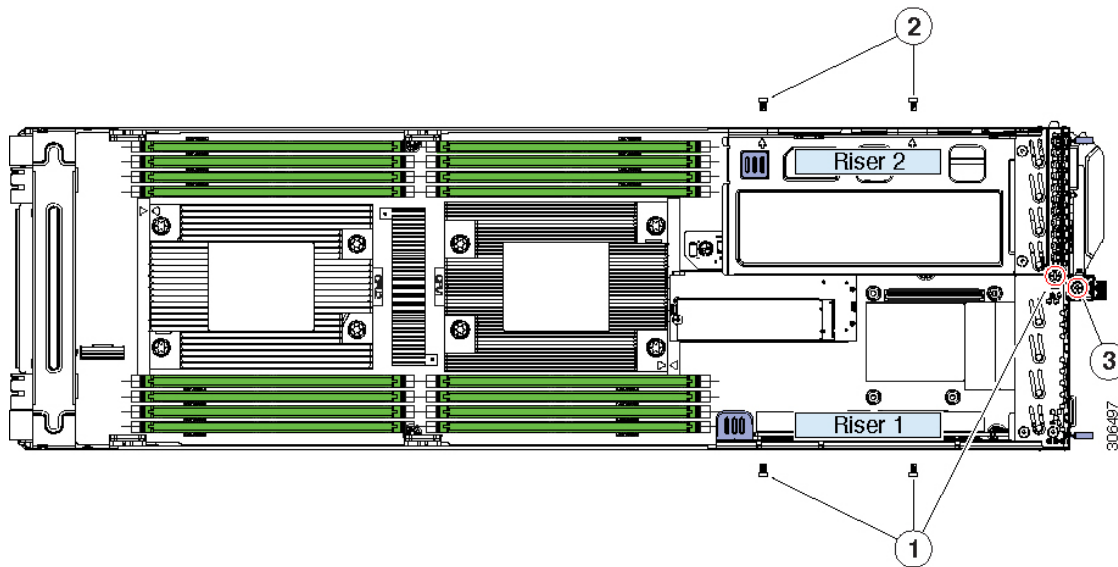

<b>1</b>	Three securing screws for riser 1 When removing riser 1, remove these three screws and then loosen the captive screw.	<b>3</b>	Captive screw
<b>2</b>	Two external securing screws for riser 2 When removing riser 2, remove the three screws for riser 1, then remove these two screws, and then loosen the captive screw.	-	

**Step 5** Remove any existing controller card that you are replacing:

- a) Disconnect the SAS cable from the connector on the card.
- b) Disconnect the supercap cable from the connector on the card.
- c) Grasp the card and pull it horizontally from the socket on the riser.

- Step 6** Install a new card:
- Align the card's edge connector with the socket on the riser while you align the card's rear panel tab with the opening in the riser.
  - Gently push on both ends of the card to seat it in the socket. The card's rear panel tab must be even with the rear panel of the riser.
  - Connect the supercap cable to the connector on the new card.
  - If you are using SAS, connect the SAS cable to the SAS connector on the card.
- Step 7** Install PCIe riser 1:
- Position PCIe riser 1 over its socket on the node board.
  - Carefully push down on both ends of the PCIe riser to fully engage its connector with the socket on the board.
  - Install and tighten the screws that you removed.
- Step 8** Return the node to the chassis:
- With the node ejector lever fully open, align the new node with the empty bay.
  - Push the server node into the bay until it engages with the midplane connectors and is flush with the chassis.
  - Rotate the ejector lever toward the center until it lays flat.
  - Tighten the thumbscrew on the ejector lever to secure the node in the chassis bay.
- Step 9** Reconnect any cables that you removed.
- Step 10** Power on the node.
- Step 11** If your server is running in standalone mode, use the Cisco Host Upgrade Utility (HUU) to update the controller firmware and program the correct suboem-id for the controller in this server.

**Note** **For servers running in standalone mode only:** After you replace controller hardware, you must run the Cisco UCS Host Upgrade Utility (HUU) to update the controller firmware, even if the firmware Current Version is the same as the Update Version. This is necessary to program the controller's suboem-id to the correct value for the server SKU. This issue does not affect servers controlled in UCSM mode.

See the HUU guide for your Cisco IMC release for instructions on downloading and using the utility to bring server components to compatible levels: [HUU Guides](#).

---

## Storage Controller Card Firmware Compatibility

Firmware on the storage controller must be verified for compatibility with the current Cisco IMC and BIOS versions that are installed on the node. If not compatible, upgrade or downgrade the storage controller firmware using the Host Upgrade Utility (HUU) for your firmware release to bring it to a compatible level.

See the HUU guide for your Cisco IMC release for instructions on downloading and using the utility to bring server components to compatible levels: [HUU Guides](#).



---

**Note** **For nodes running in standalone mode only:** After you replace controller card hardware, you must run the Cisco UCS Host Upgrade Utility (HUU) to update the controller firmware, even if the firmware Current Version is the same as the Update Version. This is necessary to program the controller's suboem-id to the correct value for the server SKU. If you do not do this, drive enumeration might not display correctly in the software. This issue does not affect servers controlled in UCSM mode.

---

# Replacing an OCP Adapter Card

Each node in the system supports one OCP adapter card that provides rear-panel LAN ports. The cards supported are:

- Dual 10 Gb Base-T (RJ-45 connectors)
- Dual 10/25 Gb SFP28 (SFP28 connectors)
- Single 100 Gb InfiniBand/Ethernet (QSFP 28 connector)



---

**Note** Each type of card has a unique adapter panel that frames the ports in the node rear panel. If you change OCP adapter type, you must also change the adapter panel.

---



---

**Caution** Always shut down the node before removing it from the chassis, as described in the procedures. Failure to shut down the node before removal results in the corresponding RAID supercap cache being discarded and other data might be lost.

---

---

**Step 1** Shut down the node by using the software interface or by pressing the node power button, as described in [Shutting Down and Removing Power From a Node, on page 7](#).

**Step 2** Disconnect any cables from ports on the node or installed cards.

**Step 3** Remove the node from the system:

- a) Loosen the captive thumbscrew on the ejector lever of the node.
- b) Rotate the ejector lever to the outside to evenly disengage the node from its midplane connectors.
- c) Pull the node straight out from the system.

**Step 4** Remove PCIe riser 1 to provide clearance:

- a) Use a #2 Phillips screwdriver to remove three screws (see the figure below).
- b) Grasp the two gripping points on the riser and lift it straight up from the socket on the board (see the blue gripping points in the following figure).
- c) Set the riser upside-down.



Figure 21: PCIe Risers

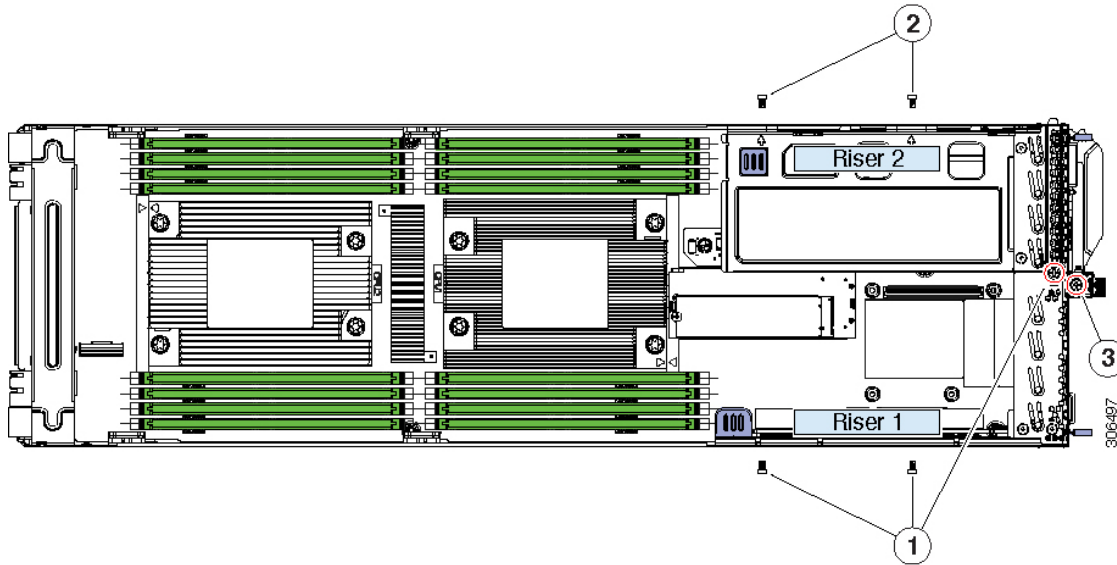

<p><b>1</b></p>	<p>Three securing screws for riser 1 When removing riser 1, remove these three screws and then loosen the captive screw.</p>	<p><b>3</b></p>	<p>Captive screw</p>
<p><b>2</b></p>	<p>Two external securing screws for riser 2 When removing riser 2, remove the three screws for riser 1, then remove these two screws, and then loosen the captive screw.</p>	<p>-</p>	

**Step 5**

Remove any existing OCP adapter card:

- a) Use a #1 Phillips screwdriver to remove the four screws that secure the card to the threaded standoffs on the node floor.
- b) Grasp the edges on both side of the card and lift it straight up to disconnect it from the OCP card socket(s).

**Step 6**

Only if you are changing OCP card type, replace the adapter panel that frames the ports in the node rear panel or a blanking panel (otherwise, skip this step):

Table 10: OCP Cards and Adapter Panels

OCP Card	Adapter Panel
<p>Dual Port 10G BASE-T UCSC-OCP-QD10GC</p>	<p>UCSC-OCP-10BTG</p>
<p>Dual Port 10G/25G SFP28 UCSC-OCP-QD25GF</p>	<p>UCSC-OCP-1025G</p>
<p>Single Port 100G QSFP 28 UCSC-OCP-QS100GF</p>	<p>UCSC-OCP-100G</p>

Replacing an OCP Adapter Card

- a) Remove the two securing screws from the adapter panel (see the following figure).
- b) Slide the adapter panel free from the node. Note how the bottom part of the adapter panel slides below the node board.
- c) Slide the new adapter panel onto the node, ensuring that the two screwholes align with holes in the node.
- d) Install the two screws that secure the adapter panel.

**Step 7**

Install a new OCP card:

- a) Align the OCP card over the OCP card socket(s) on the node board.

There are two OCP card sockets on the board. OCP cards that require a x8 lane use only socket B. Other OCP cards that require a x16 lane use both sockets A and B..

- b) Ensure that the ports on the card are aligned with the openings in the adapter panel and then press down gently to seat the card in the socket(s).
- c) Install the four screws that secure the card to the threaded standoffs below the card.

**Figure 22: OCP Card Sockets and OCP Adapter Panel**

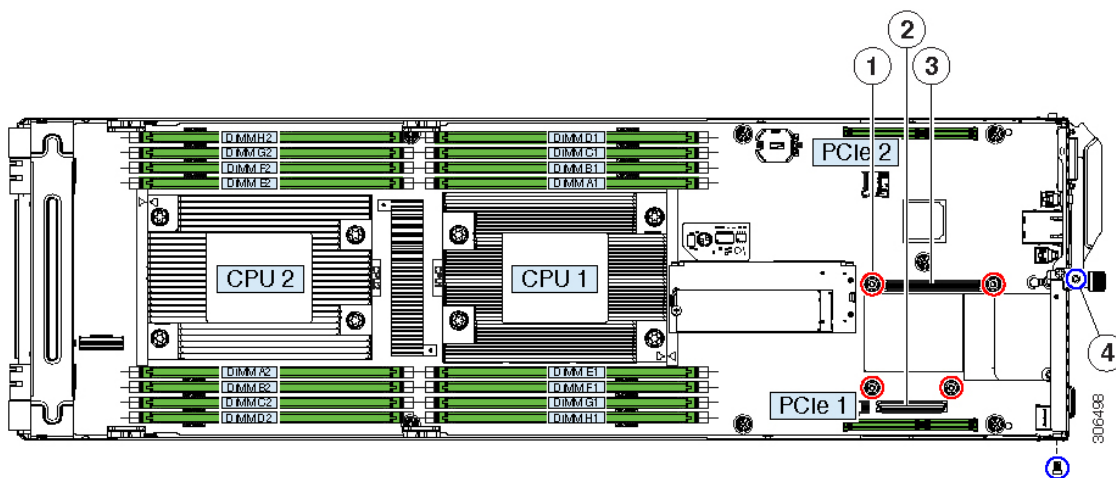

<b>1</b>	Threaded standoffs for OCP card securing screws (four, circled in red)	<b>3</b>	OCP card socket B OCP cards that require a x8 lane use only socket B. Other OCP cards that require a x16 lane use both sockets A and B.
<b>2</b>	OCP card socket A OCP cards that require a x8 lane use only socket B. Other OCP cards that require a x16 lane use both sockets A and B.	<b>4</b>	OCP card adapter panel securing screws (two, circled in blue)

**Step 8**

Install PCIe riser 1:

- a) Position PCIe riser 1 over its socket on the node board.
- b) Carefully push down on both ends of the PCIe riser to fully engage its connector with the socket on the board.
- c) Install and tighten the screws that you removed.

**Step 9**

Return the node to the chassis:

- a) With the node ejector lever fully open, align the new node with the empty bay.

- b) Push the server node into the bay until it engages with the midplane connectors and is flush with the chassis.
- c) Rotate the ejector lever toward the center until it lays flat.
- d) Tighten the thumbscrew on the ejector lever to secure the node in the chassis bay.

**Step 10** Reconnect any cables that you removed.

**Step 11** Power on the node.

## Recycling the PCB Assembly (PCBA)

Each server node has a PCBA that is connected to the blade server's faceplate and sheet metal tray. You must disconnect the PCBA from the server node's sheet metal tray to recycle the PCBA. Each server node is attached to the tray by M3.5x0.6mm screws.

Perform this procedure for each server node PCBA you will be recycling.

### Before you begin



**Note** **For Recyclers Only!** This procedure is not a standard field-service option. This procedure is for recyclers who will be reclaiming the electronics for proper disposal to comply with local eco design and e-waste regulations.

To remove the printed circuit board assembly (PCBA), the following requirements must be met:

- The server must be disconnected from facility power.
- The server must be removed from the equipment rack.
- The server node must be removed from the server chassis. See [Replacing a Node, on page 10](#).

**Step 1** Remove the screws from the faceplate.

The following image shows the location of the screws.

**Figure 23: Location of Faceplate Screws**

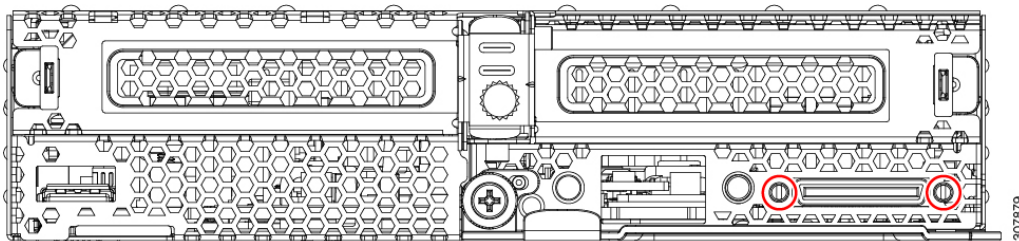

**Step 2** Detach the ribbon cable from the node's PCBA by hand.

The following image shows the cable location.

Figure 24: Location of the Ribbon Cable Connector

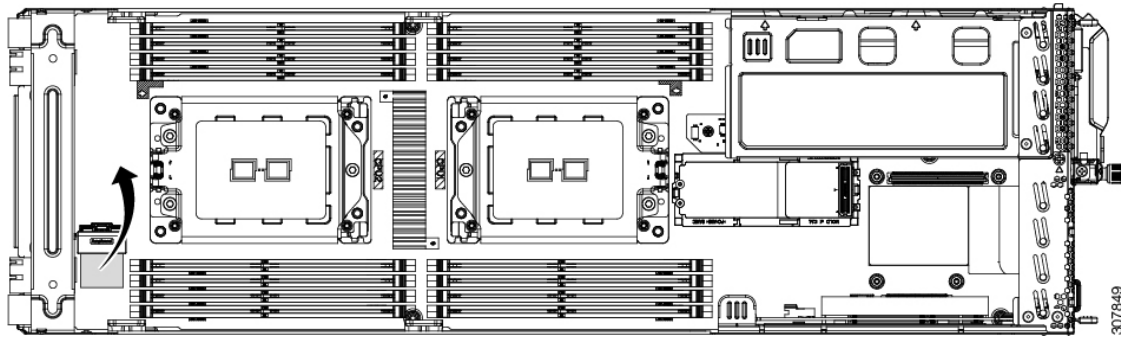

**Step 3**

Using a screwdriver, rotate each of the component mounting screws until it disengages.

The following figure shows the location of these screws.

Figure 25: Location of Component Mounting Screws

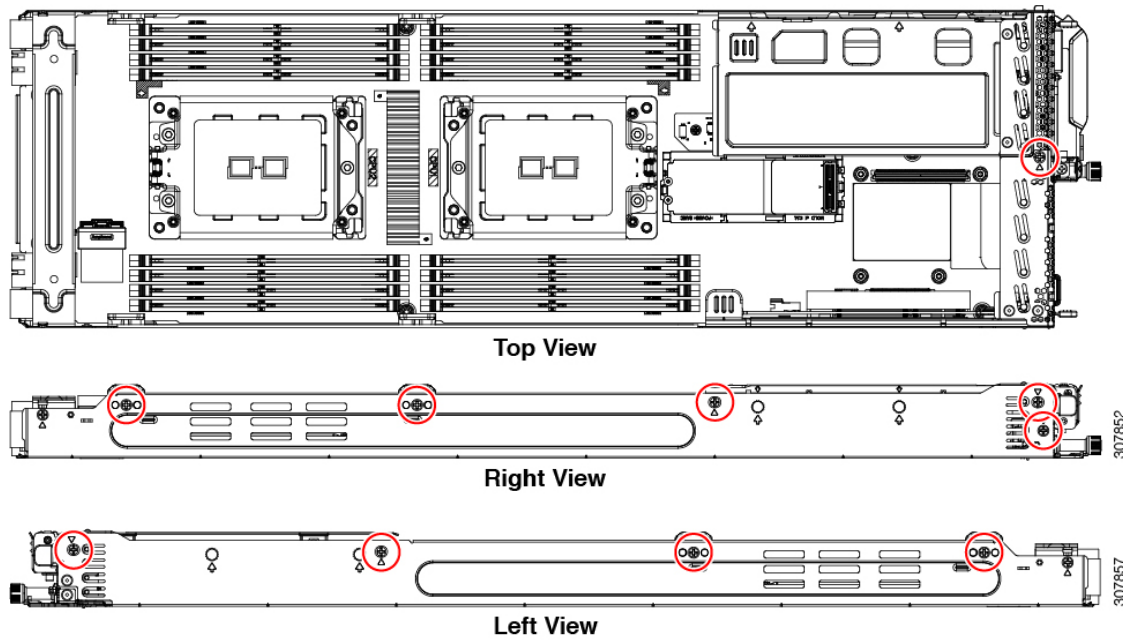

**Step 4**

Grasp the riser card module and remove it by hand.

For each riser module, repeat this step.

The following figure shows the location of the riser card module.

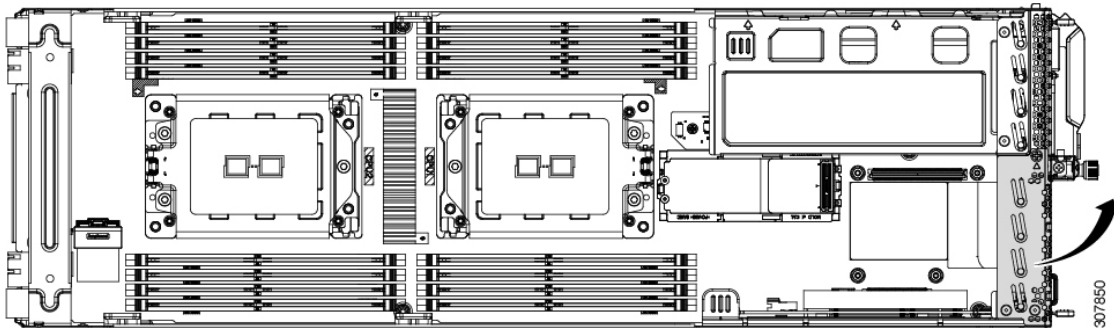
**Figure 26: Location of the Riser Card****Step 5**

Detach the PCB module from the riser frame.

- a) Rotate each of the screws by hand until it disengages.
- b) Grasp the PC board and separate it from the riser module frame by hand.

The following image shows the screws.

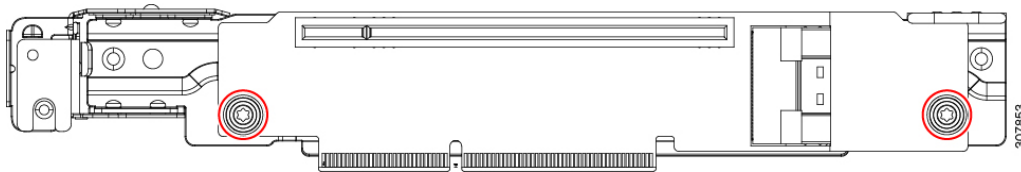
**Figure 27: Riser Board and Location of Screws****Step 6**

Remove the plastic guide clips on the sides of the server node.

The following figure shows the location of these parts.

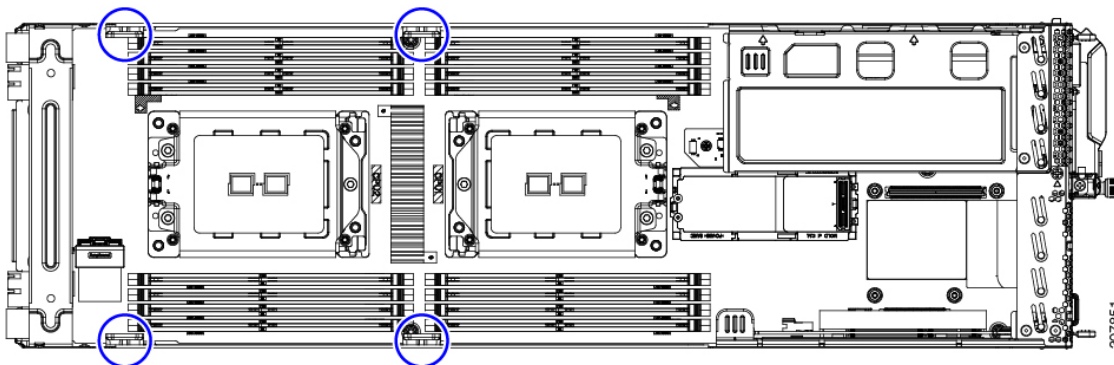
**Figure 28: Location of Plastic Guide Clips****Step 7**

Grasp the rear bracket and remove it by hand.

The following image shows the location of this part.

Figure 29: Location of Rear Bracket

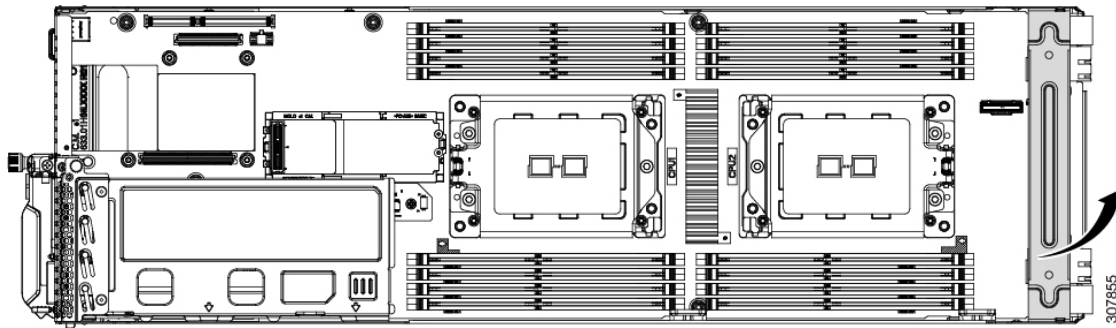

- Step 8** Using pliers, grasp the head of the TPM screw and rotate it counter-clockwise until it disengages. The following image shows the location of the screw.

Figure 30: Location of the TPM Screw

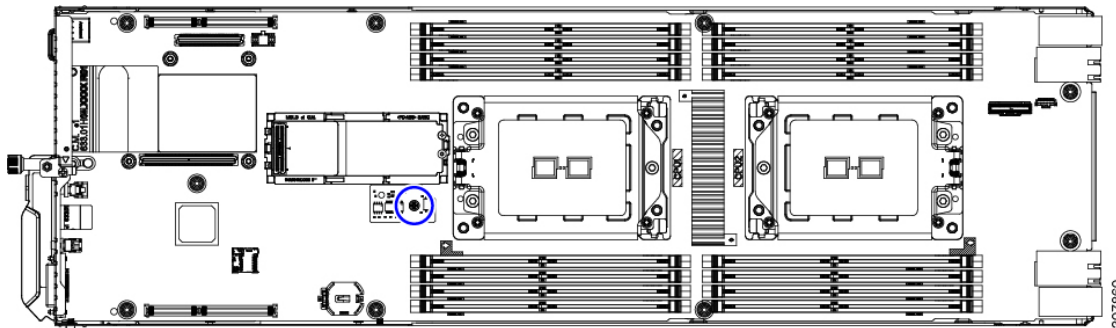

- Step 9** Remove the PCBA.
- Using a screwdriver, rotate each of the mounting crews until it disengages.
  - Detach the PCBA from the sheet metal tray.

The following image shows the location of these screws.

Figure 31: Location of PCBA Mounting Screws

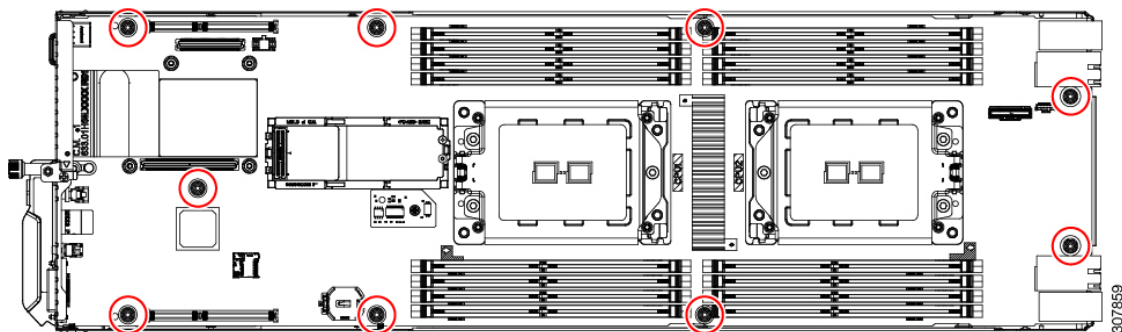

- Step 10** Dispose of the PCBA and components properly.



## APPENDIX A

# Storage Controller Information

This appendix contains information and considerations for the supported storage controller.

- [Supported Storage Controllers and Cables, on page 53](#)
- [Storage Controller Card Firmware Compatibility, on page 54](#)
- [Storage Controller Cabling, on page 54](#)
- [For More RAID Utility Information, on page 56](#)

## Supported Storage Controllers and Cables

At this time, the node supports these storage control options (either one or the other):

- SAS RAID control with a RAID card installed in PCIe riser 1 and a preinstalled SAS cable.
- SATA pass-through JBOD control with a SATA cable attached to the Slimline connector on PCIe riser 1.

The controller in each node controls up to six front-panel SAS/SATA drives, in the group that corresponds to the node's position in the chassis (group 1, 2, 3, 4)

This server supports the controller options and cable requirements shown in the following table.

Controller	Server Version/Maximum Drives Controlled	RAID Levels	Optional Supercap Backup?	Required Cables
Broadcom 9400-8i 6G SATA / 12G SAS controller UCSC-9400-8I	Six front-loading SAS/SATA drives in the C4200 chassis.	Non-RAID	No	Use the SAS cable UCSC-SAS-C125 (preinstalled in the node) and connect it between the SAS connector on the card and the board connector.

Cisco 12G 9460-8i RAID Controller Includes 2-GB flash-backed write cache (FBWC) UCSC-SAS9460-8i	Six front-loading SAS/SATA drives in the C4200 chassis.	0, 1, 5, 6, 10, 50, 60	Yes The RAID controller in each node is backed up by one supercap unit that installs to the C4200 chassis.	Use the SAS cable UCSC-SAS-C125 (preinstalled in the node) and connect it between the SAS connector on the card and the board connector.  If installing a RAID controller card to the node for the first time, you can order the card, supercap, SAS cable, and supercap cable as kit UCSC-RAID-C125-KIT.
SATA pass-through JBOD	Six front-loading SATA drives in the C4200 chassis.	Non-RAID	No	Use cable UCSC-SATA-C125 and connect it between the Slimline connector on PCIe riser 1 and the board connector.

## Storage Controller Card Firmware Compatibility

Firmware on the storage controller must be verified for compatibility with the current Cisco IMC and BIOS versions that are installed on the node. If not compatible, upgrade or downgrade the storage controller firmware using the Host Upgrade Utility (HUU) for your firmware release to bring it to a compatible level.

See the HUU guide for your Cisco IMC release for instructions on downloading and using the utility to bring server components to compatible levels: [HUU Guides](#).



---

**Note** **For nodes running in standalone mode only:** After you replace controller card hardware, you must run the Cisco UCS Host Upgrade Utility (HUU) to update the controller firmware, even if the firmware Current Version is the same as the Update Version. This is necessary to program the controller's suboem-id to the correct value for the server SKU. If you do not do this, drive enumeration might not display correctly in the software. This issue does not affect servers controlled in UCSM mode.

---

## Storage Controller Cabling

This topic shows the cable routing for storage control. Whether you are using the SAS cable with the RAID controller card or the SATA cable plugged into riser 1, the cable routing and the front cable connector location are the same.

In the following figure, the red and blue lines represent the path for routing cables from PCIe riser 1 to the connectors at the front of the node board.



Figure 32: Storage Controller Cable Routing

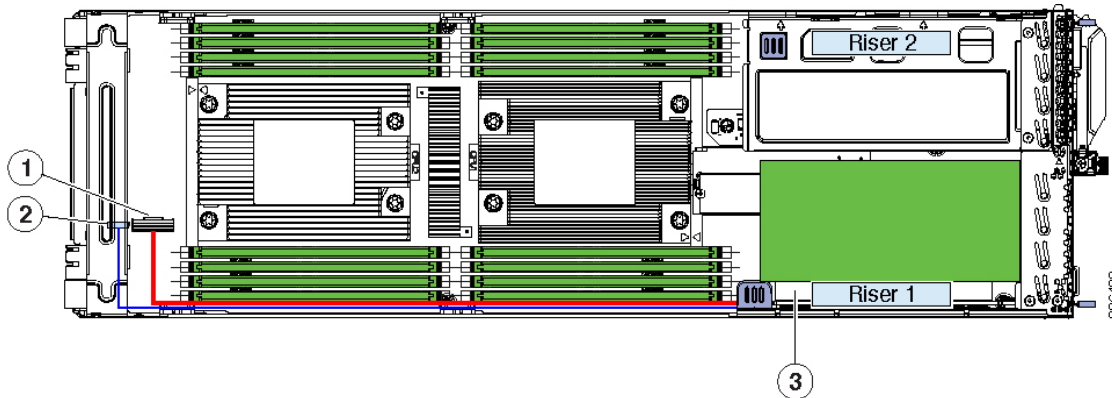

1	<p>Connector location for SAS or SATA cable</p> <p>At the other end of the cable:</p> <ul style="list-style-type: none"> <li>• A SAS cable plugs into the socket on the RAID card.</li> <li>• Alternatively, a SATA cable plugs into the Slimline connector on riser 1 to provide pass-through JBOD control.</li> </ul>	3	PCIe Riser 1 with RAID card installed horizontally
2	<p>Connector location for supercap cable</p> <p>The other end of the supercap cable plugs into the connector on the SAS RAID card.</p>	-	

The following figure shows the two connectors on the board of PCIe riser 1.

Figure 33: PCIe Riser 1 Connectors

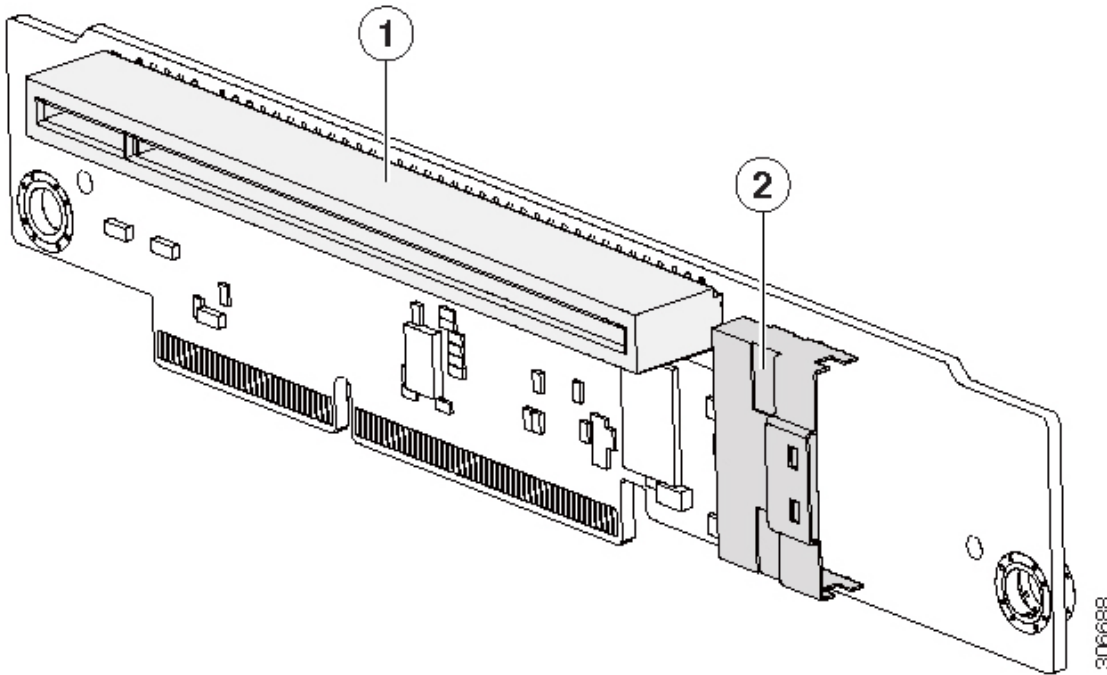

1	PCIe card socket for RAID controller card (Gen-3 x8 lane, x16 connector length)	2	Slimline connector for SATA JBOD cable UCSC-SATA-C125 (Gen-3 x8 lane)
---	---	---	---

## For More RAID Utility Information

The Broadcom utilities have help documentation for more information about using the utilities.

- For basic information about RAID and for using the utilities for the RAID controller cards that are supported in Cisco servers, see the [Cisco UCS Servers RAID Guide](#).
- For hardware SAS MegaRAID configuration—[Broadcom 12Gb/s MegaRAID SAS Software User Guide, Version 2.8](#)