



Cisco UCS Director Bare Metal Agent Installation and Configuration Guide, Release 6.5

First Published: 2017-07-11

Last Modified: 2017-09-13

Americas Headquarters

Cisco Systems, Inc.
170 West Tasman Drive
San Jose, CA 95134-1706
USA
<http://www.cisco.com>
Tel: 408 526-4000
800 553-NETS (6387)
Fax: 408 527-0883

THE SPECIFICATIONS AND INFORMATION REGARDING THE PRODUCTS IN THIS MANUAL ARE SUBJECT TO CHANGE WITHOUT NOTICE. ALL STATEMENTS, INFORMATION, AND RECOMMENDATIONS IN THIS MANUAL ARE BELIEVED TO BE ACCURATE BUT ARE PRESENTED WITHOUT WARRANTY OF ANY KIND, EXPRESS OR IMPLIED. USERS MUST TAKE FULL RESPONSIBILITY FOR THEIR APPLICATION OF ANY PRODUCTS.

THE SOFTWARE LICENSE AND LIMITED WARRANTY FOR THE ACCOMPANYING PRODUCT ARE SET FORTH IN THE INFORMATION PACKET THAT SHIPPED WITH THE PRODUCT AND ARE INCORPORATED HEREIN BY THIS REFERENCE. IF YOU ARE UNABLE TO LOCATE THE SOFTWARE LICENSE OR LIMITED WARRANTY, CONTACT YOUR CISCO REPRESENTATIVE FOR A COPY.

The Cisco implementation of TCP header compression is an adaptation of a program developed by the University of California, Berkeley (UCB) as part of UCB's public domain version of the UNIX operating system. All rights reserved. Copyright © 1981, Regents of the University of California.

NOTWITHSTANDING ANY OTHER WARRANTY HEREIN, ALL DOCUMENT FILES AND SOFTWARE OF THESE SUPPLIERS ARE PROVIDED "AS IS" WITH ALL FAULTS. CISCO AND THE ABOVE-NAMED SUPPLIERS DISCLAIM ALL WARRANTIES, EXPRESSED OR IMPLIED, INCLUDING, WITHOUT LIMITATION, THOSE OF MERCHANTABILITY, FITNESS FOR A PARTICULAR PURPOSE AND NON-INFRINGEMENT OR ARISING FROM A COURSE OF DEALING, USAGE, OR TRADE PRACTICE.

IN NO EVENT SHALL CISCO OR ITS SUPPLIERS BE LIABLE FOR ANY INDIRECT, SPECIAL, CONSEQUENTIAL, OR INCIDENTAL DAMAGES, INCLUDING, WITHOUT LIMITATION, LOST PROFITS OR LOSS OR DAMAGE TO DATA ARISING OUT OF THE USE OR INABILITY TO USE THIS MANUAL, EVEN IF CISCO OR ITS SUPPLIERS HAVE BEEN ADVISED OF THE POSSIBILITY OF SUCH DAMAGES.

Any Internet Protocol (IP) addresses and phone numbers used in this document are not intended to be actual addresses and phone numbers. Any examples, command display output, network topology diagrams, and other figures included in the document are shown for illustrative purposes only. Any use of actual IP addresses or phone numbers in illustrative content is unintentional and coincidental.

Cisco and the Cisco logo are trademarks or registered trademarks of Cisco and/or its affiliates in the U.S. and other countries. To view a list of Cisco trademarks, go to this URL: <http://www.cisco.com/go/trademarks>. Third-party trademarks mentioned are the property of their respective owners. The use of the word partner does not imply a partnership relationship between Cisco and any other company. (1110R)

© 2017 Cisco Systems, Inc. All rights reserved.



CONTENTS

Preface

Preface vii

Audience vii

Recommended Knowledge vii

Conventions viii

Related Documentation ix

Documentation Feedback ix

Obtaining Documentation and Submitting a Service Request x

CHAPTER 1

New and Changed Information for this Release 1

New and Changed Information 1

CHAPTER 2

Overview 3

Cisco UCS Director Bare Metal Agent 3

Minimum System Requirements 3

Guidelines and Limitations 4

Network Configuration Options 5

Provisioning Bare Metal Servers through Bare Metal Agent 7

Upgrade of Bare Metal Agent 7

CHAPTER 3

Installing Cisco UCS Director Bare Metal Agent 9

Installing Cisco UCS Director Bare Metal Agent on VMware vSphere 9

Installing Cisco UCS Director Bare Metal Agent on Microsoft Hyper-V 10

CHAPTER 4

Configuring Cisco UCS Director Bare Metal Agent 13

Adding a Bare Metal Agent Account 13

Configuring the DHCP Server for a Bare Metal Agent Account 15

Associating a Bare Metal Agent to Cisco UCS Director 16

- Configuring the Interface for the PXE Network 17
- Adding an NFS Mount Point 18
- Uploading an OS Image File 18
- Viewing and Editing the OS Configuration File Details 20
- Cloning an OS Configuration File 20
- Swapping the OS Configuration File Details 21
- Provisioning an OS Image 21

CHAPTER 5**Managing Bare Metal Agent 23**

- Changing the Default Bare Metal Agent Account 23
- Starting and Stopping Bare Metal Agent Services 24
- Checking the Status of a Bare Metal Agent 24
- Viewing the DHCP Configuration for a Bare Metal Agent Account 25
- Viewing the DHCP Logs for a Bare Metal Agent Account 25
- Viewing the Logs for a Bare Metal Agent Account 25
- Viewing Operating System Images 26
- Viewing PXE Service Requests 26
- Viewing the Network Interface Details for a Bare Metal Agent Account 27
- Shelladmin Script for Bare Metal Agent 27
- Setting Up UEFI as Network Boot Manager 28

CHAPTER 6**Adding Non-Windows OS Images 29**

- Adding a Non-Windows OS Image in Bare Metal Agent 29
- Manually Adding a Linux OS Image in Bare Metal Agent 31
- Manually Adding a VMware vSphere ESXi OS Image in Bare Metal Agent 32

CHAPTER 7**Adding Windows OS Images 35**

- Windows Operating Systems Supported for Cisco UCS Director Bare Metal Agent 35
- Guidelines and Limitations for Windows Operating System Images 36
- Windows Server 2008 R2 x64 Operating System Images 36
 - Prerequisites for Setting Up Windows Server 2008 R2 x64 Operating System Images 37
- Creating a Customized WinPE 37
- Preparing Windows Server 2008 R2 Installation Files 39
- Creating a Boot Configuration Data File 40
- Verifying the Installation files For All Editions of Windows 2008 R2 42

Customizing and Copying the WinPE.wim and PXE Boot Files for Windows 2008 R2	42
Copying the Customized Windows Installation Files to the Bare Metal Agent VM	45
Windows Server 2012 x64 and 2012 R2 x64 Operating System Images	46
Prerequisites for Setting Up Windows Server 2012 x64 and 2012 R2 x64 Operating System Images	46
Creating a Custom WinPE and Copying the PXE Supported Files for Windows 2012	47
Creating a Custom WinPE and Copying the PXE Supported Files for Windows 2012 R2	49
Installing and Setting Up the Boot Configuration Data File	52
Copying the Windows Installation Files to the Server Folder	53
Windows Server 2016 x64 Operating System Images	54
Prerequisites for Setting Up Windows Server 2016 x64 Operating System Images	54
Creating a Custom WinPE and Copying the PXE Supported Files for Windows 2016	55
Installing and Setting Up the Boot Configuration Data File	57
Copying the Windows Installation Files to the Server Folder	59
Using MEMDISK for Deploying Multiple Versions of Windows Simultaneously	59
Requirements for Using MEMDISK	60
Creating Bootable WINPE File for Windows Server 2008 R2, 2012, 2012 R2, or 2016	60
Modifying MAC File Template	61

CHAPTER 8
Provisioning OS Images through Orchestration Workflow Tasks 63

Orchestration Workflow Tasks for PXE Boot	63
Prerequisites for Workflows with PXE Boot Tasks	64
Execution of the Setup PXE Boot Tasks	65
Determining the Windows OS Edition	66
Inputs for the Setup PXE Boot Task	67
Inputs for the Setup PXE Boot with BMA Selection Task	70
Inputs for the Setup Windows PXE Boot Task	73
Outputs from the Setup PXE Boot Task and Setup Windows PXE Boot Task	76
Creating a PXE Boot Request in Cisco UCS Director	76
Viewing the PXE Request Configuration Files	80
PXE Boot States	80
Monitor PXE Boot Setup Task	81
Inputs for the Monitor PXE Boot Task	81
Outputs from the Monitor PXE Boot Task	81
Remove PXE Boot Setup Task	81

Inputs for the Remove PXE Boot Setup Task	81
Outputs from the Remove PXE Boot Setup Task	82
Injecting Drivers When Installing RHEL 7 or CentOS 7 on UCS Modular Servers	82
Simultaneous Provisioning of Windows Server Operating Systems	83
Files and Folders Used In Simultaneous Deployment	83
Example: Simultaneous Deployment of Windows Server Operating Systems	84

APPENDIX A

Sample Operating System Configuration Template Files	89
Sample Linux Configuration Template Files	89
Sample Kickstart Configuration Template File for Linux Operating Systems	89
Sample PXE Configuration Template File for Linux Operating Systems	91
Sample iPXE Configuration Template File for Linux Operating Systems	91
Sample VMware vSphere ESXi Configuration Template Files	91
Sample Kickstart Configuration Template File for VMware vSphere ESXi Operating Systems	91
Sample PXE Configuration Template File for VMware vSphere ESXi Operating Systems	92
Sample iPXE Configuration Template File for VMware vSphere ESXi Operating Systems	93
Sample iPXE UEFI Configuration Template File for Windows	93
Sample Windows Answer File	93

APPENDIX B

Ports	97
Cisco UCS Director TCP and UDP Port Usage	97
Cisco UCS Director TCP and UDP Port Usage on VMware vSphere	98
Cisco UCS Director TCP and UDP Port Usage on Microsoft Hyper-V	99
Port List	99
Multi-Node Port Requirements	101



Preface

- [Audience, page vii](#)
- [Conventions, page viii](#)
- [Related Documentation, page ix](#)
- [Documentation Feedback, page ix](#)
- [Obtaining Documentation and Submitting a Service Request, page x](#)

Audience

This guide is intended primarily for data center administrators who use Cisco UCS Director and who have responsibilities and expertise in one or more of the following:

- Server administration
- Storage administration
- Network administration
- Network security
- Virtualization and virtual machines

Recommended Knowledge

To deploy and manage Cisco UCS Director Bare Metal Agent, you should be familiar with the following:

- DHCP configuration
- PXE boot
- TFTP functionality
- HTTP functionality
- Linux
- Virtualization technologies

Conventions

Text Type	Indication
GUI elements	GUI elements such as tab titles, area names, and field labels appear in this font . Main titles such as window, dialog box, and wizard titles appear in this font .
Document titles	Document titles appear in <i>this font</i> .
TUI elements	In a Text-based User Interface, text the system displays appears in <i>this font</i> .
System output	Terminal sessions and information that the system displays appear in <i>this font</i> .
CLI commands	CLI command keywords appear in this font . Variables in a CLI command appear in <i>this font</i> .
[]	Elements in square brackets are optional.
{x y z}	Required alternative keywords are grouped in braces and separated by vertical bars.
[x y z]	Optional alternative keywords are grouped in brackets and separated by vertical bars.
string	A nonquoted set of characters. Do not use quotation marks around the string or the string will include the quotation marks.
<>	Nonprinting characters such as passwords are in angle brackets.
[]	Default responses to system prompts are in square brackets.
!, #	An exclamation point (!) or a pound sign (#) at the beginning of a line of code indicates a comment line.



Note

Means *reader take note*. Notes contain helpful suggestions or references to material not covered in the document.



Caution

Means *reader be careful*. In this situation, you might perform an action that could result in equipment damage or loss of data.

**Tip**

Means *the following information will help you solve a problem*. The tips information might not be troubleshooting or even an action, but could be useful information, similar to a Timesaver.

**Timesaver**

Means *the described action saves time*. You can save time by performing the action described in the paragraph.

**Warning****IMPORTANT SAFETY INSTRUCTIONS**

This warning symbol means danger. You are in a situation that could cause bodily injury. Before you work on any equipment, be aware of the hazards involved with electrical circuitry and be familiar with standard practices for preventing accidents. Use the statement number provided at the end of each warning to locate its translation in the translated safety warnings that accompanied this device.

SAVE THESE INSTRUCTIONS

Related Documentation

Cisco UCS Director Documentation Roadmap

For a complete list of Cisco UCS Director documentation, see the *Cisco UCS Director Documentation Roadmap* available at the following URL: http://www.cisco.com/en/US/docs/unified_computing/ucs/ucs-director/doc-roadmap/b_UCSDirectorDocRoadmap.html.

Cisco UCS Documentation Roadmaps

For a complete list of all B-Series documentation, see the *Cisco UCS B-Series Servers Documentation Roadmap* available at the following URL: <http://www.cisco.com/go/unifiedcomputing/b-series-doc>.

For a complete list of all C-Series documentation, see the *Cisco UCS C-Series Servers Documentation Roadmap* available at the following URL: <http://www.cisco.com/go/unifiedcomputing/c-series-doc>.

**Note**

The *Cisco UCS B-Series Servers Documentation Roadmap* includes links to documentation for Cisco UCS Manager and Cisco UCS Central. The *Cisco UCS C-Series Servers Documentation Roadmap* includes links to documentation for Cisco Integrated Management Controller.

Documentation Feedback

To provide technical feedback on this document, or to report an error or omission, please send your comments to ucs-director-docfeedback@cisco.com. We appreciate your feedback.

Obtaining Documentation and Submitting a Service Request

For information on obtaining documentation, using the Cisco Bug Search Tool (BST), submitting a service request, and gathering additional information, see [What's New in Cisco Product Documentation](#).

To receive new and revised Cisco technical content directly to your desktop, you can subscribe to the [What's New in Cisco Product Documentation RSS feed](#). RSS feeds are a free service.



CHAPTER

1

New and Changed Information for this Release

This chapter contains the following section:

- [New and Changed Information, page 1](#)

New and Changed Information

The following table provides an overview of the significant changes to this guide for the current release. The table does not provide an exhaustive list of all changes made to this guide or of all new features in this release.

Table 1: New and Changed Information for Release 6.5

Feature	Description	Where Documented
Support for deploying different versions of Windows simultaneously	Now you can simultaneously deploy different versions of Windows from a single BMA. Earlier you could deploy only one version of Windows simultaneously from a single BMA.	Using MEMDISK for Deploying Multiple Versions of Windows Simultaneously, on page 59
Manage BMA Account through UCS Director	Provides an option to upload the OS images to a Bare Metal Agents account and provision the OS images.	Uploading an OS Image File, on page 18
View and report PXE Request Configuration	Provides an option to create a PXE boot request by choosing Administration > Physical Accounts and clicking Bare Metal Agents .	Creating a PXE Boot Request in Cisco UCS Director, on page 76
Windows 2016 - Hyper-V / OS options	Supports Windows Hyper-V 2016 Baremetal OS installation.	Windows Server 2016 x64 Operating System Images, on page 54
Support for vSphere/ESXi 6.5	Supports vSphere/ESXi 6.5 Baremetal OS installation.	Adding a Non-Windows OS Image in Bare Metal Agent, on page 29

Feature	Description	Where Documented
Network status via GUI	Provides an option to view the Network Interface Details for a Bare Metal Agent Account.	Viewing the Network Interface Details for a Bare Metal Agent Account, on page 27



Overview

This chapter contains the following sections:

- [Cisco UCS Director Bare Metal Agent, page 3](#)
- [Minimum System Requirements, page 3](#)
- [Guidelines and Limitations, page 4](#)
- [Network Configuration Options, page 5](#)
- [Provisioning Bare Metal Servers through Bare Metal Agent, page 7](#)
- [Upgrade of Bare Metal Agent, page 7](#)

Cisco UCS Director Bare Metal Agent

Cisco UCS Director Bare Metal Agent (BMA) automates the process of using a Preboot Execution Environment (PXE) to install operating systems on bare metal servers or virtual machines. Bare Metal Agent provides the following services that are required for a functional PXE install environment:

- Dynamic Host Control Protocol (DHCP)
- Hypertext Transfer Protocol (HTTP)
- Trivial File Transfer Protocol (TFTP)

When this environment is operational and Bare Metal Agent and Cisco UCS Director are correctly configured, you can build PXE installation tasks into any Cisco UCS Director infrastructure workflow.

You can access Bare Metal Agent through Secure Shell (SSH). You can also perform services on Bare Metal Agent, such as DHCP configuration and starting and stopping services, through Cisco UCS Director. A single Cisco UCS Director node can support multiple Bare Metal Agent applications.

Minimum System Requirements

For proper installation and operation of Bare Metal Agent, your environment must meet the minimum system requirements.

Minimum Requirements for VMware vSphere

Name	Requirements
VMware vCenter Server	4.0 and later
Minimum reservation in VMware vCenter	Minimum number of CPUs—2 Memory—3 GB Hard disk—40 GB

Minimum Requirements for Microsoft Hyper-V

Name	Requirements
Hyper-V	Windows Server 2008 R2 or Windows Server 2012 with one of the following: <ul style="list-style-type: none"> • 2.0 • 3.1
Minimum reservation in Hyper-V	Minimum number of CPUs—2 Memory—3 GB Hard disk—40 GB

Guidelines and Limitations

Before you install Bare Metal Agent, take note of the following guidelines and limitations.

Bare Metal Agent Connections

Each Bare Metal Agent application can connect to only one Cisco UCS Director node.

Network Availability

After installation and configuration, your environment must have the following network availability:

- Bare Metal Agent must be able to reach Cisco UCS Director over the network.
- Cisco UCS Director must be able to reach Bare Metal Agent over the network.
- The bare metal servers (blade or rack) must be able to reach the DHCP network of the Bare Metal Agent during the initial stage of operating system installation over PXE.

DHCP Configuration

If you use DHCP, locate a DHCP server in the same PXE VLAN as Bare Metal Agent. Then configure that DHCP server with the IP address range required by your DHCP server.

VLAN Configuration

When setting up the network configuration, the most common configuration uses one PXE VLAN and one Management VLAN (separate VLANs). However, Bare Metal Agent supports one VLAN for both, if you prefer.

Configure the VLANs end-to-end between Cisco UCS, Cisco UCS Director, and Bare Metal Agent. However, when you configure Bare Metal Agent, do not assume that routing occurs between the PXE_VLAN Layer 2 network and the Management VLAN network.

If you configure Bare Metal Agent to use DHCP, locate and configure the DHCP server in the PXE VLAN and its subnet. This DHCP server serves the transient IP address required for the PXE process. In an environment with two VLANs, the server is allocated an IP address from the subnet of the Management VLAN. An IP address pool managed by Cisco UCS Director assigns this IP address.

If you configure Bare Metal Agent with two VLANs, set up two IP address attributes:

- An IP address for Bare Metal Agent in the PXE VLAN
- A second IP address for Bare Metal Agent in the Management VLAN

TFTP Server

With Bare Metal Agent, use the Cisco UCS Director TFTP server to ensure that configurations such as dynamic variables function properly.

When you add a Bare Metal Agent account, Bare Metal Agent configures the TFTP server when services are started.

Network Configuration Options

You can choose between the following network configuration options for Bare Metal Agent

- Single network for management and Preboot Execution Environment (PXE)
- Separate networks for management and PXE

Choose the network configuration option that best meets the requirements of your environment.

Single Network for Management and PXE

We recommend that you choose this network configuration option if your environment permits the following to be hosted on the same VLAN (Layer 2) network (see the following figure):

- Services provided by Bare Metal Agent, such as DHCP, TFTP, and HTTP

- Management traffic between Bare Metal Agent and Cisco UCS Director or other devices and appliances

Figure 1: Sample Topology for a Single Network

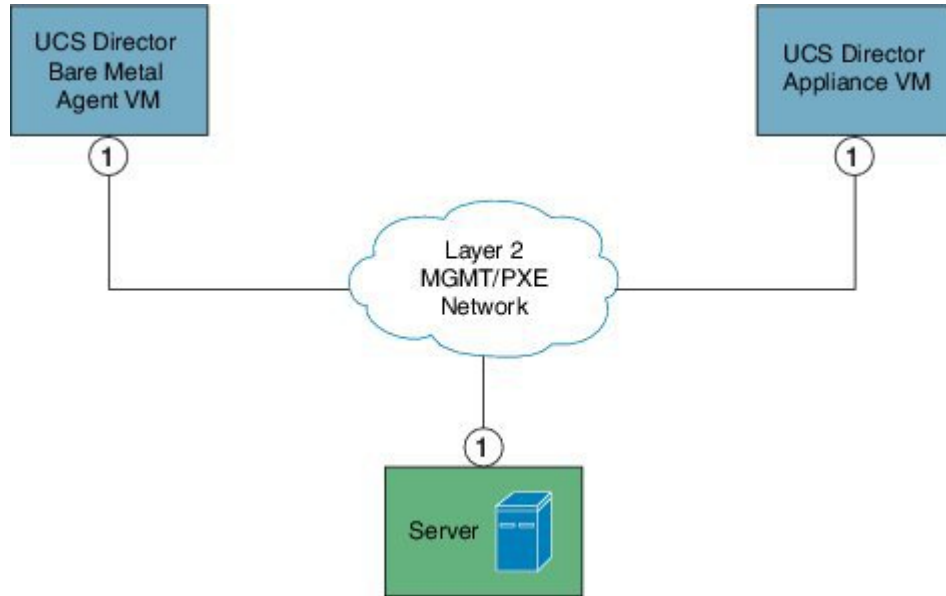

302310

Separate Networks for Management and PXE

We recommend that you choose this network configuration option if your environment does not permit the following to be hosted on the same network interface and Layer 2 network (see the following figure):

- On the PXE network, services provided by Bare Metal Agent, such as DHCP, TFTP, and HTTP
- On the Management network, traffic between Bare Metal Agent and Cisco UCS Director or other devices and appliances

Figure 2: Sample Topology for Separate PXE and Management Networks

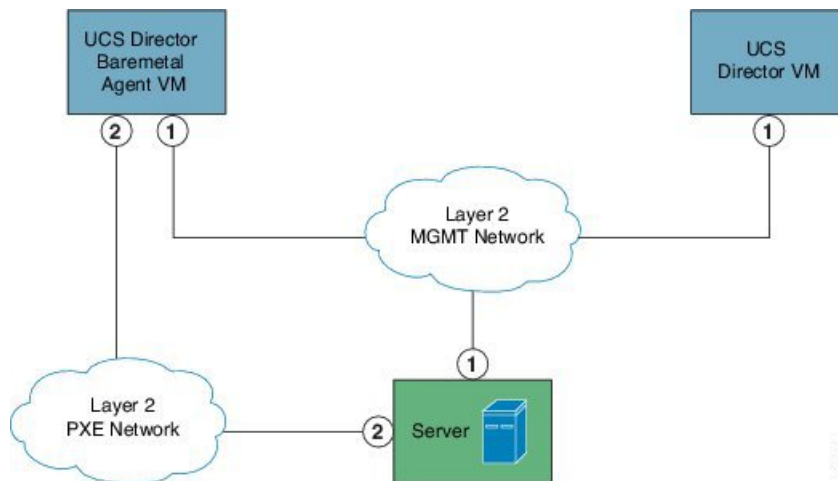

302313

Prerequisites and Assumptions for a Network Configuration

Make sure that your environment meets the following prerequisites for Bare Metal Agent network configuration:

- Cisco UCS Director has been installed and the network interface configured, as described in the appropriate [Cisco UCS Director installation guide](#).
- Cisco UCS Director Bare Metal Agent is reachable through a web browser and you can log in.
- Bare Metal Agent has been installed, and no additional configuration has been performed.
- For a single network configuration, make sure that the required single Management and PXE VLAN is provisioned and available as a virtual port group or port profile that virtual machines (VMs) can be attached to or leveraged.
- For a separate network configuration, make sure that the following networks are provisioned and available as a virtual port group or port profile that VMs can be attached to or leveraged:
 - Management (MGMT) network—Used for traffic between Bare Metal Agent and Cisco UCS Director
 - PXE network—Used for PXE services traffic, such as DHCP, HTTP, and TFTP

Provisioning Bare Metal Servers through Bare Metal Agent

The process involved in installing operating systems on bare metal servers through Bare Metal Agent is as follows:

- Install Bare Metal Agent. See [Installing Cisco UCS Director Bare Metal Agent](#), on page 9.
- Configure Bare Metal Agent. See [Configuring Cisco UCS Director Bare Metal Agent](#), on page 13.
- Add OS images in Bare Metal Agent. See [Adding Windows OS Images](#), on page 35 or [Adding Non-Windows OS Images](#), on page 29.
- Deploy OS images on bare metal servers through workflow tasks. See [Provisioning OS Images through Orchestration Workflow Tasks](#), on page 63.

For managing Bare Metal Agent operations through Cisco UCS Director, see [Managing Bare Metal Agent](#), on page 23.

Upgrade of Bare Metal Agent

For detailed information on upgrading Bare Metal Agent, see the [Cisco UCS Director Upgrade Guide](#).



Installing Cisco UCS Director Bare Metal Agent

This chapter contains the following sections:

- [Installing Cisco UCS Director Bare Metal Agent on VMware vSphere, page 9](#)
- [Installing Cisco UCS Director Bare Metal Agent on Microsoft Hyper-V, page 10](#)

Installing Cisco UCS Director Bare Metal Agent on VMware vSphere

Before You Begin

- You must have system administrator privileges for VMware vSphere or vCenter.
- If you want to use a static IP address rather than DHCP, you must know the following information:
 - IP address
 - Subnet mask
 - Default gateway

Procedure

- Step 1** On the Cisco.com download site for Cisco UCS Director, download Cisco UCS Director Bare Metal Agent and unzip the OVF file.
- Step 2** Log in to VMware vSphere Client.
- Step 3** In the **Navigation** pane, click the vSphere host on which you want to deploy Cisco UCS Director Bare Metal Agent.
- Step 4** Choose **File > Deploy OVF Template**.
- Step 5** On the **Source** screen of the **Deploy OVF Template** window, do one of the following to choose your OVF source location and then click **Next**:
 - If the OVF file is stored on your local computer, browse to the location, choose the file, and click **Open**.

- If the OVF file is stored on a server on your local area network, enter the location of the file including the IP address or fully qualified domain name of the server.

- Step 6** On the **OVF Template Details** screen, verify the details and click **Next**.
- Step 7** On the **End User License Agreement** screen, review the license agreement and click **Accept**.
- Step 8** On the **Name and Location** screen, do the following:
- In the **Name** field, enter a unique name for the VM.
 - In the **Inventory Location** area, choose the location where you want the VM to reside.
 - Click **Next**.
- Step 9** On the **Storage** screen, choose the storage location for the VM and click **Next**.
- Step 10** On the **Disk Format** screen, click **Next** to accept the default radio button for **Thick Provision (Lazy Zeroed)** format.
- Step 11** On the **Network Mapping** screen, choose the network for the VM and click **Next**.
- Step 12** On the **Properties** screen, do the following:
- Configure the IP addresses for both the NICs (eth0 and eth1) that you want to assign, as follows:
 - To use DHCP to assign the IP addresses, leave the default of 0.0.0.0 in the IP address fields.
 - To use static IP addresses, enter the desired IP addresses in the IP address fields. If you only want to configure one NIC, only complete one set of IP addresses and leave the second set at the default.
 - Click **Next**.
- Step 13** On the **Ready to Complete** screen, verify the settings and click **Finish**.
A message appears to indicate that Cisco UCS Director Bare Metal Agent is being deployed.
- Step 14** On the **Navigation** pane, right-click the VM host and choose **Edit Settings**.
- Step 15** Make sure that the VM host has sufficient resources to power on.
For more information about the required resources, see [Minimum System Requirements](#), on page 3.
- Step 16** Power on the VM.

Installing Cisco UCS Director Bare Metal Agent on Microsoft Hyper-V



Note

We recommend that you deploy Cisco UCS Director Bare Metal Agent on the Hyper-V Manager host, rather than the Microsoft System Center Virtual Machine Manager (SCVMM) console.

Before You Begin

- You must have system administrator privileges for Microsoft Hyper-V.
- If you want to use a static IP address rather than DHCP, you must know the following information:

- IP address
- Subnet mask
- Default gateway

Procedure

- Step 1** On the Cisco.com download site for Cisco UCS Director, download Cisco UCS Director Bare Metal Agent and unzip the *.vhd file into a folder.
- Step 2** Log into the Hyper-V host.
- Step 3** Choose **Start** > **Administrative Tools** to open Hyper-V Manager.
- Step 4** On the **Hyper-V Manager** screen, choose **Action** > **New Virtual Machine**.
- Step 5** In the **Before You Begin** pane, click **Next** to accept the custom configuration option.
- Step 6** In the **Specify Name and Location** pane, enter a unique name for the virtual machine (VM) name in the **Name** field.
- Step 7** In the **Name and Location** pane, do the following:
 - a) Check the **Store the virtual machine in a different location** checkbox.
 - b) Enter the alternate location.
 - c) Click **Next**.
- Step 8** In the **Assign Memory** pane, enter the amount of memory to allocate to this VM (3 GB minimum) and click **Next**.
- Step 9** In the **Configure Networking** pane, in the **Connection** field, click **Next** to accept the **Not Connected** default option.
- Step 10** In the **Connect Virtual Hard Disk** pane, click **Next** to accept the **Attach a virtual disk later** default option.
- Step 11** In the **Completing the New Virtual Machine Wizard** pane, verify the settings and click **Finish**.
- Step 12** In the left pane, right-click the VM and choose **Edit Settings**.
- Step 13** Delete the existing network adapter and click **Apply**.
- Step 14** In the **Navigation** pane, click **Processor**.
- Step 15** In the **Number of virtual processors** field, enter **2 vCPU**.
- Step 16** In the **Navigation** pane, click **Add Hardware**.
- Step 17** In the **Add Hardware** pane, choose the **Legacy Network Adapter** and click **OK**.
- Step 18** In the **Legacy Network Adapter** pane, in the **Virtual Switch** drop-down list, choose the virtual network device.
- Step 19** In the **Navigation** pane, click **IDE Controller**.
- Step 20** In the **IDE Controller** pane, choose **Hard Drive** and click **Add**.
- Step 21** Browse to the .vhd file and choose it.
- Step 22** Click **Apply**, and then click **OK**.
- Step 23** Power on the VM to configure network properties.
Optionally, you can configure network properties from the Shell Admin.

Note Only when a BMA appliance is associated with a Cisco UCS Director, the dbkeys and dbcreds files are copied to a specific location in the BMA appliance to establish successful connectivity to the Cisco UCS Director. After installing the BMA, you need to add the BMA appliance to Cisco UCS Director.

What to Do Next

After Cisco UCS Director Bare Metal Agent has started, configure DHCP or a static IP address.



Configuring Cisco UCS Director Bare Metal Agent

This chapter contains the following sections:

- [Adding a Bare Metal Agent Account, page 13](#)
- [Configuring the DHCP Server for a Bare Metal Agent Account, page 15](#)
- [Associating a Bare Metal Agent to Cisco UCS Director, page 16](#)
- [Configuring the Interface for the PXE Network, page 17](#)
- [Adding an NFS Mount Point, page 18](#)
- [Uploading an OS Image File, page 18](#)
- [Viewing and Editing the OS Configuration File Details, page 20](#)
- [Cloning an OS Configuration File, page 20](#)
- [Swapping the OS Configuration File Details, page 21](#)
- [Provisioning an OS Image, page 21](#)

Adding a Bare Metal Agent Account

Before You Begin

Before you add a Bare Metal Agent account, do the following:

- Make sure that the Bare Metal Agent is installed.



Note

You are not prompted to enter the BMA root passwords during installation. However, the first time you log in to Cisco UCS Director after installation is completed, you are prompted to enter the default root password. The default password is pxeboot.

- Make sure that the Bare Metal Agent VM is completely booted up, login to Bare Metal Agent VM Console to view the Management IP address.

- Login to Bare Metal Agent through VM Console or SSH client to access the CLI and change the default root password using the **passwd root** command.
- Set up the environment required to support a single or separate PXE and Management network configuration, with the appropriate VLANs.
- To provide required DHCP services, ensure that the PXE interface of the Bare Metal Agent is connected to PXE VLAN network and configure DHCP service with an appropriate IP address range.

Procedure

Step 1 Choose **Administration > Physical Accounts**.

Step 2 On the **Physical Accounts** page, click **Bare Metal Agents**.

Step 3 On the **Add Bare Metal Agent Appliance** screen complete the following fields:

Name	Description
Account Name field	The name you assign to this Bare Metal Agent account.
Description field	(Optional) A description of this Bare Metal Agent.
Bare Metal Agent uses different interfaces for mgmt and PXE traffic check box	Check this box if your configuration uses separate networks for the PXE server and the management network that hosts the traffic manager.
Management/PXE Address field	The IP address assigned to the Management network for Bare Metal Agent. If your configuration uses a single network for the Management and PXE networks, this IP address is automatically assigned as the PXE address. Note This address must be reachable from Cisco UCS Director.
PXE Interface Address field	The IP address for the Bare Metal Agent PXE network, if your configuration uses separate networks. Note This field appears only if the Bare Metal Agent uses Different Interfaces for Management and PXE Traffic box has been checked.
Login ID field	An account with administrative privileges that you can use to log in to Bare Metal Agent.
Password field	The password for the account.
Enable Samba service for Windows PXE check box	Samba is used for Bare Metal Agent to install Windows Operating Systems. Check this box if you want to install Windows Operating Systems.
Samba Password field	Enter the password for the Samba service.

Name	Description
Confirm Samba Password field	Confirm the password for the Samba service.
Location field	(Optional) The location of this Bare Metal Agent, such as a physical location.
Database Address drop-down list	Bare Metal Agent requires access to the Cisco UCS Director database. Choose the IP address of Cisco UCS Director which is on the same Management network as the Bare Metal Agent. Note If you are configuring the Bare Metal Agent for the Cisco UCS Director multi-node deployment, choose the IP address of the Inventory Database node.

Step 4 Click **Submit**.

What to Do Next

Configure the DHCP Server for Bare Metal Agent.

Configuring the DHCP Server for a Bare Metal Agent Account



Note For a multi-home DHCP configuration, use this procedure to configure the first subnet for the DHCP server. For the remaining subnets, you must manually edit the DHCP configuration file (`/etc/dhcpd.conf`).

Before You Begin

To provide required DHCP services, ensure that at least one DHCP server is located in the same PXE VLAN as Bare Metal Agent. Configure the DHCP server with an appropriate IP address range. The DHCP server, together with the TFTP server, is used to communicate with a PXE server.

Procedure

Step 1 Log in to the Cisco UCS Director server with the following credentials:

- a) User—admin

b) Password—admin

Step 2 Choose **Administration > Physical Accounts**.

Step 3 On the **Physical Accounts** page, click **Bare Metal Agents**.

Step 4 Click the row for the Bare Metal Agent account for which you want to configure the DHCP server.

Step 5 Click **Service Status** to verify that services for the Bare Metal Agent account are stopped.

Step 6 Click **Configure DHCP**.

Step 7 On the **Configure DHCP** screen, complete the following fields and click **Submit**.

- **DHCP Subnet**
- **DHCP Netmask**
- **DHCP Start IP**
- **DHCP End IP**
- **Router IP Address**

The DHCP IP address assignments are updated, and the DHCP service is restarted.

Step 8 Click the row for the Bare Metal Agent account and click **Start Services**.

Step 9 After the services have started, do the following:

- Verify that the status of the account in the **Status** column is Active.
- Verify that the **Enabled Services** column shows that all services are running. If this status indicates that one or more services are stopped, verify the configuration of your DHCP server and try again.
- Click **Service Status** to verify that the status of all expected services is up:
 - Network Services status in the Bare Metal Agent appliance
 - Database connectivity status from the Bare Metal Agent appliance

Note When there is no dedicated PXE boot network configured in the Bare Metal Agent and only one Management interface is used for PXE boot, then the DHCP Server IP range should be different from the IP range used in MGMT IP pool for cluster creation in Cisco UCS Director Express for Big Data.

What to Do Next

Set up PXE boot requests.

Associating a Bare Metal Agent to Cisco UCS Director

To establish a connection between the Bare Metal Agent and Cisco UCS Director, you need to associate the Bare Metal Agent to Cisco UCS Director.

Procedure

- Step 1** Log in to Cisco UCS Director deployed with the compatible version of the Bare Metal Agent.
 - Step 2** Choose **Administration > Physical Accounts**.
 - Step 3** On the **Physical Accounts** page, click **Bare Metal Agents**.
 - Step 4** Add a Bare Metal Agent account. See [Adding a Bare Metal Agent Account](#), on page 13.
 - Step 5** Click the row for the Bare Metal Agent account and click **Start Services**. It might take around two minutes for the services to start.
 - Step 6** After the services have started, verify that the status of the account in the **Status** column is Active. It might take two minutes for the status to reflect as Active. When status of the BMA service is active, the BMA is ready for use.
- Note** Only when the BMA services are started from the Cisco UCS Director UI, the dbkeys and dbcreds files are copied to a specific location in the BMA appliance to establish successful connectivity to the Cisco UCS Director.
-

Configuring the Interface for the PXE Network

You can use this to change or add an IP address for the PXE network used by Bare Metal Agent.

Procedure

- Step 1** Choose **Administration > Physical Accounts**.
 - Step 2** On the **Physical Accounts** page, click **Bare Metal Agents**.
 - Step 3** Click the row for the Bare Metal Agent account for which you want to configure the interface for the PXE network.
 - Step 4** Click **Configure Interface**.
 - Step 5** On the **Configure PXE Interface** screen, complete the following fields:
 - a) From the **Interface Name** drop-down list, choose the interface that you want to use for the PXE network.
 - b) Enter the IP address and subnet mask for the PXE network.
 - c) Click **Submit**.
-

Adding an NFS Mount Point

Procedure

-
- Step 1** Choose **Administration > Physical Accounts**.
 - Step 2** On the **Physical Accounts** page, click **Bare Metal Agents**.
 - Step 3** Click the row for the Bare Metal Agent account for which you want to view PXE service requests.
 - Step 4** Click **View Details**.
 - Step 5** Click **NFS Mount Point**.
 - Step 6** Click **Add**.
 - Step 7** On the **Add NFS Mount Point** screen, do the following:
 - a) In the **NFS Server IP Address** field, enter the IP address of the NFS server where you plan to store the OS images for Bare Metal Agent to use.
 - b) In the **NFS Server Path** field, enter the location on the NFS server where the OS images are stored.
 - c) Click **Submit**.

After you add the NFS mount point, all content in the `imageRepository` folder in the NFS server is available under the `/mnt/external` folder. You include this path in the `isoExtractor.sh` file when you create a non-Windows image template.

Uploading an OS Image File

Procedure

-
- Step 1** Choose **Administration > Physical Accounts**.
 - Step 2** On the **Physical Accounts** page, click **Bare Metal Agents**.
 - Step 3** Click the row for the Bare Metal Agent account for which you want to upload the OS image.
 - Step 4** From the **More Actions** drop-down list, click **View Details**.
 - Step 5** Click **Image Repository**.
 - Step 6** Click **Upload Image**.
 - Step 7** On the **Image Upload** screen, complete the following fields:

Name	Description
Image Name field	The name of the OS image.
OS Type drop-down list	Choose the OS image type that you want to install on the server. The drop-down list includes all OS types supported by the Bare Metal Agent.

Name	Description
Upload Type drop-down list	Choose one of the following: <ul style="list-style-type: none"> • Desktop File • The web server path that is reachable by the Cisco UCS Director Bare Metal Agent to upload remote software to Bare Metal Agent.
File field	This field is displayed when you choose the Desktop File option in the Upload Type drop-down list. To upload the file, you can either drag and drop the required file or click Select and click Submit .
Web URL field	This field is displayed when you choose the Web Server Path option in the Upload Type drop-down list. Enter the web server path where the ISO images are stored and click Submit .
MD5 Checksum field	This field is displayed when you choose the Web Server Path option in the Upload Type drop-down list. (Optional) Enter the MD5 checksum value of the downloaded file which is used to verify the data integrity.

Step 8 Click **Submit**. The details of the uploaded image is displayed.

Step 9 Click the row for the OS image for which you want to view the upload log details.

Step 10 Click **Show Upload Log**. The upload log details of the image is displayed.

Viewing and Editing the OS Configuration File Details

Procedure

- Step 1** Choose **Administration > Physical Accounts**.
 - Step 2** On the **Physical Accounts** page, click **Bare Metal Agents**.
 - Step 3** Click the row for the Bare Metal Agent account.
 - Step 4** From the **More Actions** drop-down list, click **View Details**.
 - Step 5** Click **OS Catalogs**.
 - Step 6** Click the row for the OS catalog for which you want to view the configuration details.
 - Step 7** Click **View Configuration Files**.
 - Step 8** On the **View Configuration Files** screen, choose a file. The configuration details for the file are displayed.
 - Step 9** Click the row for the OS catalog for which you want to edit the configuration details and click **Edit Configuration Files**.
 - Step 10** On the **Modify Configuration Files** screen, choose the required file from the **Select the file** drop-down list and make the necessary changes.
 - Step 11** Click **Submit**.
You can delete the configuration details by clicking **View Configuration Files**.
-

Cloning an OS Configuration File

Procedure

- Step 1** Choose **Administration > Physical Accounts**.
 - Step 2** On the **Physical Accounts** page, click **Bare Metal Agents**.
 - Step 3** Click the row for the Bare Metal Agent account.
 - Step 4** From the **More Actions** drop-down list, click **View Details**.
 - Step 5** Click **OS Catalogs**.
 - Step 6** Click the row for the OS catalog for which you want to clone the configuration details.
 - Step 7** Click **Clone Configuration Files**.
 - Step 8** On the **Clone Configuration Files** screen, do the following:
 - a) Choose a file from the **Select the file** drop-down list.
 - b) Enter a unique name for the file.
 - c) Click **Submit**.
-

Swapping the OS Configuration File Details

Procedure

-
- Step 1** Choose **Administration > Physical Accounts**.
 - Step 2** On the **Physical Accounts** page, click **Bare Metal Agents**.
 - Step 3** Click the row for the Bare Metal Agent account.
 - Step 4** From the **More Actions** drop-down list, click **View Details**.
 - Step 5** Click **OS Catalogs**.
 - Step 6** Click the row for the OS catalog for which you want to swap the configuration details.
 - Step 7** Click **Swap Configuration Files**.
 - Step 8** On the **Swap Configuration Files** screen, choose the files whose details need to be swapped.
 - Step 9** Click **Submit**.
-

Provisioning an OS Image

Procedure

-
- Step 1** Choose **Administration > Physical Accounts**.
 - Step 2** On the **Physical Accounts** page, click **Bare Metal Agents**.
 - Step 3** Click the row for the Bare Metal Agent account for which you want to upload the OS image.
 - Step 4** From the **More Actions** drop-down list, click **View Details**.
 - Step 5** Click **Image Repository**.
 - Step 6** Click the row for the OS image that you want to provision.
 - Step 7** Click **Provision Image**.
 - Step 8** On the **Provision Image Catalog** screen, complete the following fields:

Name	Description
OS Type drop-down list	Choose the OS image type that needs to be provisioned in the Bare Metal Agent. The drop-down list includes all the available OS types with details such as version and update number.
Catalog Name field	Enter the catalog name.

- Step 9** Click **Provision Image**.
-



Managing Bare Metal Agent

This chapter contains the following sections:

- [Changing the Default Bare Metal Agent Account, page 23](#)
- [Starting and Stopping Bare Metal Agent Services, page 24](#)
- [Checking the Status of a Bare Metal Agent, page 24](#)
- [Viewing the DHCP Configuration for a Bare Metal Agent Account, page 25](#)
- [Viewing the DHCP Logs for a Bare Metal Agent Account, page 25](#)
- [Viewing the Logs for a Bare Metal Agent Account, page 25](#)
- [Viewing Operating System Images, page 26](#)
- [Viewing PXE Service Requests, page 26](#)
- [Viewing the Network Interface Details for a Bare Metal Agent Account, page 27](#)
- [Shelladmin Script for Bare Metal Agent, page 27](#)
- [Setting Up UEFI as Network Boot Manager, page 28](#)

Changing the Default Bare Metal Agent Account

The first Bare Metal Agent account that you create is designated as the default account. This account is used by default in legacy workflows. To use a different account in the legacy workflows, you must designate that Bare Metal Agent account as the default.

Procedure

- Step 1** Choose **Administration > Physical Accounts**.
 - Step 2** On the **Physical Accounts** page, click **Bare Metal Agents**.
 - Step 3** Click the row for the Bare Metal Agent account that you want designate as the default.
 - Step 4** Click **Set Default BMA**.
-

Starting and Stopping Bare Metal Agent Services

Procedure

- Step 1** Choose **Administration > Physical Accounts**.
- Step 2** On the **Physical Accounts** page, click **Bare Metal Agents**.
- Step 3** Click the row for the Bare Metal Agent account whose services you want to start or stop.
- Step 4** Click one of the following:
- **Start Services**
 - **Stop Services**
- Step 5** Click **Service Status** and check the status displayed in the **Enabled Services** column to ensure that services have started or stopped as desired.
- If services do not start, check the status displayed in the **Enabled Services** column. If this status indicates that services are not enabled, verify the configuration of your DHCP server and try again.
-

Checking the Status of a Bare Metal Agent

Procedure

- Step 1** Choose **Administration > Physical Accounts**.
- Step 2** On the **Physical Accounts** page, click **Bare Metal Agents**.
- Step 3** Click the row for the Bare Metal Agent account whose status you want to check.
- Step 4** To see if services for the Bare Metal Agent account are Active or Inactive, check the **Status** column.
- Step 5** To check the status of the services, click **Service Status**.
- Step 6** To view the SSH-based test connection status, check the **Reachable** column.
-

Viewing the DHCP Configuration for a Bare Metal Agent Account

Procedure

- Step 1** Choose **Administration > Physical Accounts**.
 - Step 2** On the **Physical Accounts** page, click **Bare Metal Agents**.
 - Step 3** Click the row for the Bare Metal Agent account for which you want to view the DHCP configuration.
 - Step 4** Click **View DHCP Configuration**.
You might need to click the Down arrow at the end of the button bar to access the **View DHCP Configuration** option.
The **View DHCP Server Configuration** window displays the contents of the DHCP server configuration file for the account.
-

Viewing the DHCP Logs for a Bare Metal Agent Account

Procedure

- Step 1** Choose **Administration > Physical Accounts**.
 - Step 2** On the **Physical Accounts** page, click **Bare Metal Agents**.
 - Step 3** Click the row for the Bare Metal Agent account for which you want to view the DHCP logs.
 - Step 4** Click the down arrow at the end of the button bar and choose **View DHCP Logs**.
The **View Bare Metal Agent DHCP Log** window displays the contents of the DHCP server logs for the account.
-

Viewing the Logs for a Bare Metal Agent Account

Procedure

- Step 1** Choose **Administration > Physical Accounts**.
 - Step 2** On the **Physical Accounts** page, click **Bare Metal Agents**.
 - Step 3** Click the row for the Bare Metal Agent account for which you want to view the logs.
 - Step 4** Click the down arrow at the end of the button bar and choose **View BMA Logs**.
The **View Bare Metal Agent Log** window displays the logs for the account.
-

Viewing Operating System Images

You can view a list of the operating system (OS) images that have been created and are available for a Bare Metal Agent account.

Procedure

- Step 1** Choose **Administration > Physical Accounts**.
 - Step 2** On the **Physical Accounts** page, click **Bare Metal Agents**.
 - Step 3** Click the row for the Bare Metal Agent account for which you want to view OS images.
 - Step 4** Click **View Details**.
 - Step 5** Click **BMA OS List**.
-

Viewing PXE Service Requests

You can view information about PXE requests made through a workflow that have an associated service request. You cannot view details of PXE requests that are not made through a workflow, as those requests are not associated with a service request.

The information provided about each PXE request includes the following:

- Service request ID
- Request type
- User who initiated the request
- Name of the catalog or workflow that was used to create the request
- Any comments provided by the user who initiated the request
- Time of the request
- Status of the request
- Rollback type, if applicable

Procedure

- Step 1** Choose **Administration > Physical Accounts**.
 - Step 2** On the **Physical Accounts** page, click **Bare Metal Agents**.
 - Step 3** Click the row for the Bare Metal Agent account for which you want to view PXE service requests.
 - Step 4** Click **View Details**.
 - Step 5** Click **PXE Service Requests**.
-

Viewing the Network Interface Details for a Bare Metal Agent Account

Procedure

- Step 1** Choose **Administration > Physical Accounts**.
 - Step 2** On the **Physical Accounts** page, click **Bare Metal Agents**.
 - Step 3** Click the row for the Bare Metal Agent account for which you want to view the network interface details.
 - Step 4** Click the down arrow at the end of the button bar and choose **View Details**.
 - Step 5** Click **Network Interface Summary**. The network interface details are displayed.
-

Shelladmin Script for Bare Metal Agent

Procedure

- Step 1** Navigate to `/opt/infra/bin`.
- Step 2** Run `shelladmin` script.

Example:

The following list of services appears:

```
1) Display Services Status
2) Stop Services
3) Start Services
4) Display Samba Service
5) Stop Samba Service
6) Start Samba Service
7) Change Samba Password
8) Time Sync
9) Ping Hostname/IP Address
10) Show Version
11) Configure Network Interface
12) Display Network Details
13) Add DNS Server
14) Tail Network Services Logs
15) Tail DHCP Logs
16) Change DHCP Configuration
17) Run IsoExtractor Script
18) Apply Patch
19) Shutdown Appliance
20) Reboot Appliance
21) Change Root Password
22) UCSD appliance connection
23) Quit
```

- Step 3** Choose the required option and press **Enter**.
-

Setting Up UEFI as Network Boot Manager

The following are the list of operating system supported for UEFI booting:

- Windows Server 2012, Windows Server 2012 R2, and Windows Server 2016
- ESXi 6.5 and ESXi 6.0
- RHEL 7.0 and above
- Centos 7.0 and above
- SLES 12 and above



Note RHEL 7.3 and Centos 7.3 installation are not supported for UEFI booting. OS kernels which are not compiled with EFI stub are also not supported.

Procedure

Step 1 Create a catalog from the Bare Metal Agent 6.5.

Note For Non-Windows operating system, provision the OS image from the Cisco UCS Director UI or run `isoExtractor.sh` available in `/opt/infra` folder. See, [Configuring Cisco UCS Director Bare Metal Agent, on page 13](#). However, for Windows operating system, ensure that `ipxe-uefi.cfg` and `autounattend-uefi.xml` files are available in the catalog.

Step 2 Choose **iPXE-UEFI** as the network boot manager. See, [Provisioning OS Images through Orchestration Workflow Tasks, on page 63](#).

Note iPXE-UEFI supports TFTP protocol by default. However, you can modify the `ipxe-uefi.cfg` with the following details to support the HTTP protocol. HTTP protocol with UEFI does not work on all servers.

```
#!ipxe
initrd http://$PXE_NATIVE_WEBSERVER/$PXE_OS/isolinux/initrd.img
kernel http://$PXE_NATIVE_WEBSERVER/$PXE_OS/isolinux/vmlinuz initrd=initrd.img
ks=$PXE_KS_URL net.ifnames=0 biosdevname=0
initrd http://$PXE_NATIVE_WEBSERVER/$PXE_OS/isolinux/initrd.img
boot
```



Adding Non-Windows OS Images

This chapter contains the following sections:

- [Adding a Non-Windows OS Image in Bare Metal Agent, page 29](#)
- [Manually Adding a Linux OS Image in Bare Metal Agent, page 31](#)
- [Manually Adding a VMware vSphere ESXi OS Image in Bare Metal Agent, page 32](#)

Adding a Non-Windows OS Image in Bare Metal Agent

This procedure creates a Non-Windows OS image template in Bare Metal Agent. You must add the OS image template before you can request a PXE boot for the OS image.



Note You cannot use this procedure to create supported Windows operating systems images. For more information about how to set up Windows OS images, see [Adding Windows OS Images, on page 35](#).

Before You Begin

You must have all resources and requirements in place for each operating system image that you want to install through a Bare Metal Agent PXE boot request.

Procedure

- Step 1** Copy the OS image(s) to one of the following locations:
- An appropriate location in the Bare Metal Agent directory structure
 - An NFS mount point that you have added to Bare Metal Agent
- Step 2** Navigate to `/opt/infra` and run `isoExtractor.sh`.

Example:

The following sample `isoExtractor.sh` file shows a scenario for an OS image in the Bare Metal Agent directory structure. The image path field contains the location of the VMware image in the `/opt/image/` folder.

If you have added an NFS mount point, the image path field would contain the location of the image in the `/mnt/external` folder. For example, if you want to create a CentOS image that is located in a CentOS folder in an NFS mount point, the image path field would contain `/mnt/external/CentOS/image.iso`.

```

root@localhost infra]# pwd
/opt/infra
root@localhost infra]# ./isoExtractor.sh
Please select the OS Type

    1) ESXi 4.1
    2) ESXi 5.0
    3) ESXi 5.1
    4) ESXi 5.5
    5) ESXi 6.0
    6) ESXi 6.5
    7) ESXi 5.5 VSAN
    8) ESXi 6.0 VSAN
    9) CentOS or RHEL [Pre 7.0]
   10) CentOS 7.x or RHEL 7.x
   11) SUSE Linux
   12) Other

SELECT> 4
Image path : /opt/image/VMWare-VMvisor-Installer-5.5.0-1111111.x86_64.iso

OS catalog name : BMA-184-ESXi5.5
Input file being used: /opt/images/VMware-VMvisor-Installer-5.5.0-1111111.x86_64.iso
OS catalog name being used: BMA-184-ESXi5.5
Mounting the image....
Preparing the image....
Creating catalog directory /opt/cnsaroot/templates/BMA-184-ESXi5.5
Creating configuration files for ESXi 5.5 ...
Copied the image and created the configuration files...
is /opt/cnsaroot/images/
BMA-184-ESXi5.5 centos60-small
is /opt/cnsaroot/templates/
BMA-184-ESXi5.5 CentOS60 Win2k12R2x64 Win2k12x64 Win2k8R2x64
is /opt/cnsaroot/templates/BMA-184-ESXi5.5
boot.cfg ks.cfg pxe.cfg
[root@localhost infra]#

```

- Step 3** When prompted, choose the image category and provide the image location and catalog name.
- Step 4** After the script execution is completed, navigate to `/opt/cnsaroot/images/catalogname` and confirm that the image is available in that location.
- Step 5** Navigate to `/opt/cnsaroot/templates/catalogname` and confirm that the PXE configuration templates are available in that location.
- Step 6** To verify that the OS image is created, do the following:
- In Cisco UCS Director, choose **Physical > Compute**.
 - In the left pane, navigate to the pod that contains the Bare Metal Agent.
 - In the right pane, click **PXE Boot Requests**.
 - Click **Add PXE Boot Request** and verify that the OS image is included in the **OS Type** drop-down list.

Manually Adding a Linux OS Image in Bare Metal Agent

Procedure

- Step 1** Create a directory for the operating system image in the `/opt/cnsaroot/images` directory of the Bare Metal Agent VM.

```
mkdir /opt/cnsaroot/images/image_name
```

This directory is used to store the operating system image files required for PXE installation.

Note This directory name is included in the **OS Type** drop-down list in the Setup PXE Boot task. We recommend that you make the directory name descriptive enough that you can identify the operating system of the images within it. For example, we recommend that you name the directory `RHEL6.2` or `CentOS5`.

- Step 2** Create a directory for the operating system image with the same name as the one that you created in Step 1 in the `/opt/cnsaroot/templates` directory of the Bare Metal Agent VM.

```
mkdir /opt/cnsaroot/templates/new_image_name
```

This directory is used to store the Kickstart and PXE configuration template files for the operating system image.

- Step 3** Copy the `.iso` file or files for the required operating system to the `/tmp` directory of the Bare Metal Agent VM.

- Step 4** Mount the `.iso` file to the `iso` directory.

```
mount -o loop /tmp/.iso_file /mnt/iso
```

- Step 5** Copy the entire contents of the `.iso` file to the `/opt/cnsaroot/images/image_name` directory that you created in Step 1.

```
cp -R /mnt/iso/* /opt/cnsaroot/images/image_name
```

Note Make sure that you use the `cp -R` command to recursively copy the entire contents of the `.iso` file. This command copies the underlying directories and their contents also.

- Step 6** When the copy operation is complete, unmount the `.iso` file.

```
umount /mnt/iso
```

- Step 7** If the operating system image consists of more than one `.iso` file, repeat Steps 5, 6, and 7 for each `.iso` file until the contents of all `.iso` files have been copied to the `/opt/cnsaroot/images/image_name` directory.

- Step 8** Create a `ks.cfg` file and a `pxe.cfg` file in the `/opt/cnsaroot/templates/image_name` directory that you created in Step 2.

```
touch /opt/cnsaroot/templates/image_name/ks.cfg  
touch /opt/cnsaroot/templates/image_name/pxe.cfg
```

- Step 9** Add the required configuration information to the `ks.cfg` and `pxe.cfg` files. For sample `ks.cfg` and `pxe.cfg` files and more information about these files, see [Sample Operating System Configuration Template Files](#), on page 89.

- Step 10** Create a soft link in the `/var/www/html` directory for this operating system image.

```
ln -s /opt/cnsaroot/images/image_name /var/www/html/
```

- Step 11** (Optional) If necessary, update the `initrd.img` and `vmlinuz` files for the operating system image as follows:
- Copy the `initrd.img` and `vmlinuz` files from the `/opt/cnsaroot/images/image_name` directory to the `/opt/cnsaroot/` directory.
 - Overwrite the current files in this location.
- Step 12** In Cisco UCS Director, verify that the operating system image is available from the **OS Type** drop-down list in the Setup PXE Boot task.
- Wait two minutes, or for whatever duration has been set for the Bare Metal Agent synchronization frequency. By default, Bare Metal Agent is synchronized with Cisco UCS Director every two minutes. You can change this frequency with the `bma.sync.frequency` property in `service.properties.template` file under `/opt/infra` in the Bare Metal Agent VM.

Manually Adding a VMware vSphere ESXi OS Image in Bare Metal Agent

Procedure

- Step 1** Create a directory for the operating system image data in the `/opt/cnsaroot` directory of the Bare Metal Agent VM.
- ```
mkdir /opt/cnsaroot/images
```
- This directory is used to store the operating system image files required for PXE installation.
- Note** This directory name is included in the **OS Type** drop-down list in the Setup PXE Boot task. We recommend that you make the directory name descriptive enough that you can identify the operating system of the images within it. For example, we recommend that you name the directory `ESXi5.0-update1` or `ESXi5.1`.
- Step 2** Create a directory for the operating system image with the same name as the one that you created in Step 1 in the `/opt/cnsaroot/templates` directory of the Bare Metal Agent VM.
- ```
mkdir /opt/cnsaroot/templates/new_image_name
```
- This directory is used to store the Kickstart and PXE configuration template files for the operating system image.
- Step 3** Copy the `.iso` file or files for the required operating system to the `/tmp` directory of the Bare Metal Agent VM.
- Step 4** Mount the `.iso` file to the `iso` directory.
- ```
mount -o loop /tmp/.iso_file /mnt/iso
```
- Step 5** Copy the entire contents of the `.iso` file to the `/opt/cnsaroot/image_name` directory that you created in Step 1.
- ```
cp -R /mnt/iso/* /opt/cnsaroot/image_name
```
- Note** Make sure that you use the `cp -R` command to recursively copy the entire contents of the `.iso` file. This command copies the underlying directories and their contents also.

- Step 6** When the copy operation is complete, unmount the `.iso` file.
- ```
umount /mnt/iso
```
- Step 7** If the operating system image consists of more than one `.iso` file, repeat Steps 5, 6, and 7 for each `.iso` file until the contents of all `.iso` files have been copied to the `/opt/cnsaroot/image_name` directory.
- Step 8** Create a `ks.cfg` file and a `pxe.cfg` file in the `/opt/cnsaroot/templates/image_name` directory that you created in Step 2.
- ```
touch /opt/cnsaroot/templates/image_name/ks.cfg
touch /opt/cnsaroot/templates/image_name/pxe.cfg
```
- Step 9** Add the required configuration information to the `ks.cfg` and `pxe.cfg` files. For sample `ks.cfg` and `pxe.cfg` files and more information about these files, see [Sample Operating System Configuration Template Files](#), on page 89.
- Step 10** Copy the `boot.cfg` file from the `/opt/cnsaroot/image_name` directory to the `/opt/cnsaroot/templates/image_name` directory.
- ```
cd /opt/cnsaroot/templates/image_name/
cp /opt/cnsaroot/image_name/boot.cfg ./
```
- Step 11** Edit the `boot.cfg` file in the `/opt/cnsaroot/templates/image_name` directory as follows:
- After the `title=` line, add a `prefix=/image_name/` line.
  - Append `pxebooting ks=$PXE_KS_URL` to the end of the `kernelopt=runweasel` line.
  - Remove the leading `/` from all modules listed in the `boot.cfg` file.
  - Save the edited file.
- Step 12** In Cisco UCS Director, verify that the operating system image is available from the **OS Type** drop-down list in the Setup PXE Boot task. Wait two minutes, or for whatever duration has been set for the Bare Metal Agent synchronization frequency. By default, Bare Metal Agent is synchronized with Cisco UCS Director every two minutes. You can change this frequency with the `bma.sync.frequency` property in **service.properties.template** file under `/opt/infra` in the Bare Metal Agent VM.
-





## Adding Windows OS Images

---

This chapter contains the following sections:

- [Windows Operating Systems Supported for Cisco UCS Director Bare Metal Agent, page 35](#)
- [Guidelines and Limitations for Windows Operating System Images, page 36](#)
- [Windows Server 2008 R2 x64 Operating System Images, page 36](#)
- [Windows Server 2012 x64 and 2012 R2 x64 Operating System Images, page 46](#)
- [Windows Server 2016 x64 Operating System Images, page 54](#)
- [Using MEMDISK for Deploying Multiple Versions of Windows Simultaneously, page 59](#)

## Windows Operating Systems Supported for Cisco UCS Director Bare Metal Agent

Cisco UCS Director Bare Metal Agent (Bare Metal Agent) supports the following Windows operating system (OS) images and the automated creation of their required answer files:

- Windows Server 2008 R2 x64
- Windows Server 2012 x64
- Windows Server 2012 R2 x64
- Windows Server 2016 x64

You can set up all four OS images in Bare Metal Agent. You can use the same answer file for both local boot and SAN boot.

The procedure for setting up a Windows OS image depend upon the operating system. Make sure you use the appropriate procedure for the OS image that you are setting up.

**Note**

---

After adding Bare Metal Agent to Cisco UCS Director and running inventory, Cisco UCS Director shows as if Windows images are added by default. But no Windows images are added. Install Windows images manually.

---

## Guidelines and Limitations for Windows Operating System Images

Consider the following guidelines and limitations when you set up Windows Server OS images for provisioning:

### Follow a Strict Naming Convention

You must follow a strict naming convention when you configure the files for Windows OS images. The paths and file names are case sensitive.

**Note**

---

Mistakes in naming will require you to modify the names throughout the Bare Metal Agent data infrastructure.

---

### Ensure That File Names, Drive Letters, and Other Information Match in All Files

If you use the automatically generated answer file, Bare Metal Agent ensures that the file names, drive letters and other information match.

However, if you manually edit the answer file, you must ensure that the drive letter in the `WinPE.wim` matches the drive letter provided in the answer file. With this configuration you are defining `WinPE.wim` such that it installs Windows from a particular location by using an answer file setup option. The static names, paths, IP addresses, drive letters, answer file name, and user name credentials must be correct.

File and folder names are case sensitive: `WinPE.wim` names must exactly match entries in the Boot Configuration Data (BCD) store.

### Use Single Path Workflow for SAN Boot

**Warning**

---

Because the Windows installation does not support multi-path SAN boot, you must use the single path workflow to achieve SAN boot.

---

## Windows Server 2008 R2 x64 Operating System Images

The Windows Server 2008 R2 x64 OS (Windows 2008 OS) supports PXE boot and installation operations. You can use this OS image in bare metal provisioning workflows.

## Prerequisites for Setting Up Windows Server 2008 R2 x64 Operating System Images

To install and set up the environment and files that are required for the setup of Windows Server 2008 R2 x64 OS images, you must first download the following:

- Windows Assessment and Deployment Kit (ADK, sometimes called as Windows ADK). See <https://www.microsoft.com/en-us/download/details.aspx?id=30652>. The Windows ADK enables you to generate a customized WinPE. Make sure Windows ADK is compatible with Windows Server 2008 R2 version.
- Windows Server 2008 R2 x64 ISO version.

**Note**

You need not manually create a Windows answer file when setting up the Windows OS images. Bare Metal Agent builds the Windows answer file necessary to support your PXE Boot request, based on the information you provide when you create the PXE boot request.

Before installing the Windows 2008 R2 operating system using the Bare Metal Agent VM, set up and configure the following prerequisites:

- A customized Windows Pre-installation Environment (WinPE)
- Boot Configuration Data (BCD) file (optional)
- Windows installation files (the files extracted from the ISO image file)

**Tip**

We recommend that you use the Windows 2008 R2 OS ISO image file, which contains all editions, including Standard, Enterprise, Datacenter, and Web. You can typically remove all editions except for Standard and Datacenter.

After customizing the WinPE image and creating the BCD file, you must do the following:

- Set up WinPE and copy the supporting files to the Bare Metal Agent VM for the PXE boot.
- Extract the Windows 2008 R2 OS ISO image files into the appropriate image repository directory.

## Creating a Customized WinPE

You need to create and customize the Windows Preinstallation Environment (WinPE) for Windows 2008 R2 x64. The initial WinPE includes the minimum boot image necessary to load kernel and default device drivers supported by the Windows OS. Most servers require additional drivers, such as network interface cards and storage controllers that enable Windows OS to detect the network and disks during installation. You must add these drivers to the WinPE.wim image.

Add the device drivers to the WinPE image by using the Deployment Image Servicing and Management (DISM.exe) command tool, which is installed with the Windows ADK. Make sure that you download the required device drivers before you execute the associated DISM commands.

**Important**

The following procedure includes a sample configuration that is for reference only. The sample configuration might or might not work in your environment. For information about adding device drivers to the WinPE image through DISM.exe, see the documentation provided by Microsoft.

**Before You Begin**

Complete the prerequisites listed in [Prerequisites for Setting Up Windows Server 2008 R2 x64 Operating System Images](#), on page 37.

Download the following:

- Windows Assessment and Deployment Kit (Windows ADK) specifically for Windows 2008 R2 x64.
- Required device drivers to be added to the WinPE.wim image.

**Procedure**

**Step 1** Launch the command prompt (click **Start** > **All Programs** > **Accessories** > **Command Prompt**).

**Step 2** Change the directory to Windows ADK installation directory.

```
cd C:\Program Files (x86)\Windows Kits\8.0\Assessment and Deployment Kit\Windows
Preinstallation Environment
```

Here, C:\Program Files (x86)\Windows Kits\8.0\Assessment and Deployment Kit\Windows Preinstallation Environment is the directory where Windows ADK has been installed.

**Step 3** Create a new WinPE environment folder using 'copyype.cmd' command.

```
copyype.cmd amd64 c:\win2k8r2x64
```

Here, c:\win2k8r2x64 is the directory where the new WinPE environment is created.

**Step 4** Extract the device drivers to a folder. For example, c:\cisco\drivers.

**Step 5** Add the device drivers to the WinPE image by using the DISM.exe command.

- Mount the WinPE.wim image:

```
DISM.exe /mount-wim /wimfile:c:\win2k8r2x64\WinPE.wim /index:1
mountdir:c:\win2k8r2x64\mount
```

- Add the device drivers to WinPE.wim image by using the individual driver's absolute path:

```
DISM.exe /image:c:\win2k8r2x64\mount /Add-Driver /driver:C:\cisco\drivers\1.inf
/driver:C:\cisco\drivers\2.inf /driver:C:\cisco\drivers\3.inf
```

- Alternatively, add the device drivers to the WinPE.wim image by automatically searching through all the subfolders of the device drivers directory:

```
DISM.exe /image:c:\win2k8r2x64\mount /Add-Driver /driver:C:\cisco\drivers /Recurse
```

**Step 6** Unmount the WinPE.wim image and commit the changes:

```
DISM.exe /unmount-wim /mountdir:c:\win2k8r2x64\mount /commit
```

When all the device drivers have been added, the WinPE.wim image is ready to be used.



## Preparing Windows Server 2008 R2 Installation Files

### Before You Begin

You must have the following in place:

- Windows Assessment and Deployment Kit (ADK, sometimes called as Windows ADK) that is compatible with the Windows 2008 R2 operating system
- Windows 2008 R2 ISO image

### Procedure

**Step 1** Launch the command prompt (click **Start** > **All Programs** > **Accessories** > **Command Prompt**).

**Step 2** Create a new folder and extract the Windows 2008 R2 ISO image installation files to the folder.

```
mkdir c:\win2k8r2x64-iso
```

**Step 3** Take a backup copy of the install.wim file.

```
cd c:\win2k8r2x64-iso\sources
copy install.wim install.wim.backup
```

The backup is recommended as device drivers will be added to the install.wim file in the subsequent steps. The device drivers are used during the installation of the Windows 2008 R2 operating system.

**Step 4** Create a folder to mount the c:\win2k8r2x64-iso\sources\install.wim file.

```
mkdir c:\win2k8r2x64-mount
```

**Step 5** Change the directory to the Windows ADK installation directory.

```
cd C:\Program Files (x86)\Windows Kits\8.0\Assessment and Deployment Kit\Deployment Tools\amd64\DISM
```

**Step 6** Add the device drivers to the install.wim image by using the DISM.exe command from the Windows ADK installation directory.

**Step 7** List the supported Windows 2008 R2 Editions.

```
dism.exe /Get-ImageInfo /imagefile:c:\win2k8r2x64-iso\sources\install.wim
```

The supported Windows 2008 R2 editions are listed, with each edition represented by an Index ID. Choose the corresponding Index ID of the Windows 2008 R2 Edition that you want to install through PXE.

```
Index : 1
Name : Windows Server 2008 R2 SERVERSTANDARD
Description : Windows Server 2008 R2 SERVERSTANDARD
Size : 10,510,509,480 bytes

Index : 2
Name : Windows Server 2008 R2 SERVERSTANDARDCORE
Description : Windows Server 2008 R2 SERVERSTANDARDCORE
Size : 3,563,998,339 bytes

Index : 3
Name : Windows Server 2008 R2 SERVERENTERPRISE
Description : Windows Server 2008 R2 SERVERENTERPRISE
Size : 10,510,890,698 bytes

Index : 4
Name : Windows Server 2008 R2 SERVERENTERPRISECORE
Description : Windows Server 2008 R2 SERVERENTERPRISECORE
Size : 3,563,972,455 bytes
```

```

Index : 5
Name : Windows Server 2008 R2 SERVERDATACENTER
Description : Windows Server 2008 R2 SERVERDATACENTER
Size : 10,510,997,874 bytes

Index : 6
Name : Windows Server 2008 R2 SERVERDATACENTERCORE
Description : Windows Server 2008 R2 SERVERDATACENTERCORE
Size : 3,564,010,572 bytes

Index : 7
Name : Windows Server 2008 R2 SERVERWEB
Description : Windows Server 2008 R2 SERVERWEB
Size : 10,520,088,768 bytes

Index : 8
Name : Windows Server 2008 R2 SERVERWEBCORE
Description : Windows Server 2008 R2 SERVERWEBCORE
Size : 3,562,616,654 bytes

```

**Step 8** Mount the install.wim image with Index ID 5 to install Windows 2008 R2 Datacenter Edition.

```
DISM.exe /mount-wim /wimfile:c:\win2k8r2x64-iso\sources\install.wim /index:5
mountdir:c:\win2k8r2x64-mount
```

**Step 9** Add device drivers to the install.wim image by using the individual driver's absolute path.

```
DISM.exe /image:c:\win2k8r2x64-mount /Add-Driver /driver:C:\cisco\drivers\1.inf
/driver:C:\cisco\drivers\2.inf /driver:C:\cisco\drivers\3.inf
```

Alternatively, you can add the device drivers to the install.wim image by automatically searching through all the subfolders of the device drivers directory.

```
DISM.exe /image:c:\win2k8r2x64-mount /Add-Driver /driver:C:\cisco\drivers /Recurse
```

**Step 10** Unmount the install.wim image and commit the changes.

```
DISM.exe /unmount-wim /mountdir:c:\win2k8r2x64-mount /commit
```

**Note** When all the device drivers have been added, the install.wim image is ready to be used.

## Creating a Boot Configuration Data File

The Boot Configuration Data (BCD) file contains the boot configuration parameters. It controls how the operating system is started in Windows and is used to load the base kernel (WinPE.wim) from the PXE server. Creating a new BCD file is optional. The Bare Metal Agent provides a BCD file with default configuration out of the box. The absolute location path of the BCD file is `/opt/cnsaroot/Boot/BCD`. The default BCD file can be used to install any Windows OS version, unless it is required to be customized for a specific version of Windows.

By default, the BCD file points to `/opt/cnsaroot/Boot/WinPE.wim` and `/opt/cnsaroot/Boot/boot.sdi` files. These filenames are case sensitive.

The new BCD file can be created through the BCDEdit command-line tool. This tool is commonly available in the Windows operating system under root directory, `C:\Windows\system32`.

## Procedure

- Step 1** Launch the command prompt (click **Start > All Programs > Accessories > Command Prompt**).
- Step 2** Create a new working directory to create a new BCD file. (At the command prompt, type `C:\> mkdir C:\NewBCDStore`)
- Step 3** Change the directory to `C:\NewBCDStore`. (At the command prompt, type `C:\> cd C:\NewBCDStore`)
- Step 4** Run the below sequence of commands to create a new BCD file:

```
C:\NewBCDStore> C:\Windows\System32\bcdedit.exe /createstore BCD
```

```
C:\NewBCDStore> C:\Windows\System32\bcdedit.exe /store BCD /create {ramdiskoptions} /d "Ramdisk options"
```

```
C:\NewBCDStore> C:\Windows\System32\bcdedit.exe /store BCD /set {ramdiskoptions} ramdisksdidevice boot
```

```
C:\NewBCDStore> C:\Windows\System32\bcdedit.exe /store BCD /set {ramdiskoptions} ramdisksdipath \Boot\boot.sdi
```

```
C:\NewBCDStore> C:\Windows\System32\bcdedit.exe /store BCD /create /d "My WinPE Boot Image" /application osloader
```

Running the above command generates and displays a new GUID as the command output.

- Step 5** Run the following commands. When you run these commands, replace the GUID (for example: `{a20f8db8-7459-11e2-8ec3-00155d37efa7}`) with the GUID generated from your system:

```
C:\NewBCDStore> C:\Windows\System32\bcdedit.exe /store BCD /set {a20f8db8-7459-11e2-8ec3-00155d37efa7} systemroot \Windows
```

```
C:\NewBCDStore> C:\Windows\System32\bcdedit.exe /store BCD /set {a20f8db8-7459-11e2-8ec3-00155d37efa7} detecthal Yes
```

```
C:\NewBCDStore> C:\Windows\System32\bcdedit.exe /store BCD /set {a20f8db8-7459-11e2-8ec3-00155d37efa7} winpe Yes
```

```
C:\NewBCDStore> C:\Windows\System32\bcdedit.exe /store BCD /set {a20f8db8-7459-11e2-8ec3-00155d37efa7} osdevice ramdisk=[boot]\Boot\WinPE.wim,{ramdiskoptions}
```

```
C:\NewBCDStore> C:\Windows\System32\bcdedit.exe /store BCD /set {a20f8db8-7459-11e2-8ec3-00155d37efa7} device ramdisk=[boot]\Boot\WinPE.wim,{ramdiskoptions}
```

```
C:\NewBCDStore> C:\Windows\System32\bcdedit.exe /store BCD /create {bootmgr} /d "Windows 2008r2 BootManager"
```

```
C:\NewBCDStore> C:\Windows\System32\bcdedit.exe /store BCD /set {bootmgr} timeout 30
```

```
C:\NewBCDStore> C:\Windows\System32\bcdedit.exe /store BCD /displayorder {a20f8db8-7459-11e2-8ec3-00155d37efa7}
```

Use the following command to verify that the configurations are correct:

```
C:\NewBCDStore> C:\Windows\System32\bcdedit.exe /store BCD /enum all
```

### What to Do Next

Verify that you have appropriate Windows 2008 R2 OS installation files inside the ISO image.

## Verifying the Installation files For All Editions of Windows 2008 R2

### Before You Begin

Mount or extract the Windows 2008 R2 ISO image.

### Procedure

Verify that you have the following CLG files under the SOURCE folder of mounted or extracted Windows 2008 R2 ISO image:

- install\_Windows Server 2008 R2 SERVERDATACENTER.clg
- install\_Windows Server 2008 R2 SERVERDATACENTERCORE.clg
- install\_Windows Server 2008 R2 SERVERENTERPRISE.clg
- install\_Windows Server 2008 R2 SERVERENTERPRISECORE.clg
- install\_Windows Server 2008 R2 SERVERSTANDARD.clg
- install\_Windows Server 2008 R2 SERVERSTANDARDCORE.clg
- install\_Windows Server 2008 R2 SERVERDATAWEB.clg
- install\_Windows Server 2008 R2 SERVERDATAWEBCORE.clg

### What to Do Next

Edit the WinPE.wim image file to add PowerShell packages and modify the startnet.cmd file with PXE install commands and parameters as described in [Customizing and Copying the WinPE.wim and PXE Boot Files for Windows 2008 R2](#), on page 42.

## Customizing and Copying the WinPE.wim and PXE Boot Files for Windows 2008 R2

### Procedure

---

**Step 1** Launch the command prompt (click **Start** > **All Programs** > **Accessories** > **Command Prompt**).

**Step 2** Change the directory to WinPE environment that was created.

```
cd c:\win2k8r2x64
```

**Step 3** Mount WinPE.wim image to a folder called 'mount' under the c:\win2k8r2x64 directory.

```
DISM.exe /mount-wim /wimfile:c:\win2k8r2x64\WinPE.wim /index:1 /mountdir:c:\win2k8r2x64\mount
```

**Step 4** In WinPE.wim, add the required PowerShell packages and edit the paths in each command with the correct mount point and ADK installation path for your environment.

**Note** The Powershell package files shown below are provided for your reference only. The PowerShell packages and file names that you need to add to WinPE.wim are dependent upon the version of Windows and WinPE.wim. To determine which PowerShell packages you need to add, see the compliance report on the Microsoft website. For information about the commands to add the necessary packages for PowerShell, see the [WinPE: Adding PowerShell support to Windows PE Technet Page](#).

```
DISM /Add-Package /Image:"C:\win2k8r2x64\mount" /PackagePath:"C:\Program Files (x86)\Windows Kits\8.0\Assessment and Deployment Kit\Windows Preinstallation Environment\amd64\WinPE_OCs\WinPE-WMI.cab"
```

```
DISM /Add-Package /Image:"C:\win2k8r2x64\mount" /PackagePath:"C:\Program Files (x86)\Windows Kits\8.0\Assessment and Deployment Kit\Windows Preinstallation Environment\amd64\WinPE_OCs\en-us\WinPE-WMI_en-us.cab"
```

```
DISM /Add-Package /Image:"C:\win2k8r2x64\mount" /PackagePath:"C:\Program Files (x86)\Windows Kits\8.0\Assessment and Deployment Kit\Windows Preinstallation Environment\amd64\WinPE_OCs\WinPE-NetFX.cab"
```

```
DISM /Add-Package /Image:"C:\win2k8r2x64\mount" /PackagePath:"C:\Program Files (x86)\Windows Kits\8.0\Assessment and Deployment Kit\Windows Preinstallation Environment\amd64\WinPE_OCs\en-us\WinPE-NetFX_en-us.cab"
```

```
DISM /Add-Package /Image:"C:\win2k8r2x64\mount" /PackagePath:"C:\Program Files (x86)\Windows Kits\8.0\Assessment and Deployment Kit\Windows Preinstallation Environment\amd64\WinPE_OCs\WinPE-Scripting.cab"
```

```
DISM /Add-Package /Image:"C:\win2k8r2x64\mount" /PackagePath:"C:\Program Files (x86)\Windows Kits\8.0\Assessment and Deployment Kit\Windows Preinstallation Environment\amd64\WinPE_OCs\en-us\WinPE-Scripting_en-us.cab"
```

```
DISM /Add-Package /Image:"C:\win2k8r2x64\mount" /PackagePath:"C:\Program Files (x86)\Windows Kits\8.0\Assessment and Deployment Kit\Windows Preinstallation Environment\amd64\WinPE_OCs\WinPE-PowerShell.cab"
```

```
DISM /Add-Package /Image:"C:\win2k8r2x64\mount" /PackagePath:"C:\Program Files (x86)\Windows Kits\8.0\Assessment and Deployment Kit\Windows Preinstallation Environment\amd64\WinPE_OCs\en-us\WinPE-PowerShell_en-us.cab"
```

```
DISM /Add-Package /Image:"C:\win2k8r2x64\mount" /PackagePath:"C:\Program Files (x86)\Windows Kits\8.0\Assessment and Deployment Kit\Windows Preinstallation Environment\amd64\WinPE_OCs\WinPE-StorageWMI.cab"
```

```
DISM /Add-Package /Image:"C:\win2k8r2x64\mount" /PackagePath:"C:\Program Files (x86)\Windows Kits\8.0\Assessment and Deployment Kit\Windows Preinstallation Environment\amd64\WinPE_OCs\en-us\WinPE-StorageWMI_en-us.cab"
```

```
DISM /Add-Package /Image:"C:\win2k8r2x64\mount" /PackagePath:"C:\Program Files (x86)\Windows Kits\8.0\Assessment and Deployment Kit\Windows Preinstallation Environment\amd64\WinPE_OCs\WinPE-DismCmdlets.cab"
```

```
DISM /Add-Package /Image:"C:\win2k8r2x64\mount" /PackagePath:"C:\Program Files (x86)\Windows Kits\8.0\Assessment and Deployment Kit\Windows Preinstallation
```

```
Environment\amd64\WinPE_OC\en-us\WinPE-DismCmdlets_en-us.cab"
```

**Step 5** Navigate to the mount folder (c:\win2k8r2x64\mount in the code example above) and verify that you can see the data inside the mount folder.

**Step 6** Navigate to \windows\system32 in the mount folder and do the following:

- a) Edit startnet.cmd.
- b) Paste the following entries into the file in the order shown, to update the IP address and other details as required for your environment:

```
wpeinit
wpeutil.exe InitializeNetwork
wpeutil.exe disablefirewall
ECHO OFF
net use R: \\Baremetal_Agent_PXE_IP_Address\bits /user:user_id password
ECHO ON
R:
Powershell.exe -NonInteractive -NoLogo -ExecutionPolicy bypass -command R:\enroute.ps1
```

**Note**

- Use the drvload command when a driver has failed to be installed. For example, include the following line in the startnet.cmd file to install a fnic driver:

```
drvload <ipaddress of share>:\\<the_fnic.inf>
```

Use the drvload command only when you face issues in installing drivers. Otherwise, follow the standard process to inject a driver to WinPE.

- Make sure that you modify the IP address in all the entries so that they point to the Bare Metal Agent IP address.
- All drive letter references (such as the reference to an R: drive) must match in both the startnet.cmd file and the Windows answer file. By default, Bare Metal Agent comes with an R: drive letter assignment.

**Step 7** Save the startnet.cmd file.

**Step 8** After you have confirmed that the startnet.cmd is updated correctly, unmount WinPE.wim with the DISM Unmount command and use the /commit option to save the modified startnet.cmd file.

```
DISM.exe /Unmount-Wim /Mountdir:c:\win2k8r2x64\mount /commit
```

**Caution** Do not leave any files open that are located in the mounted directory when you unmount WinPE.wim. If you have any files open, the unmount process might fail.

## What to Do Next

Copy the customized Windows installation files to the Bare Metal Agent VM.

# Copying the Customized Windows Installation Files to the Bare Metal Agent VM

## Before You Begin

You must have the following in place:

- Customized WinPE.wim image file
- Customized install.wim image file
- Customized BCD file (optional)
- Windows 2008 R2 ISO image

## Procedure

- 
- Step 1** Copy the following files into the Bare Metal Agent VM. You can use either WinSCP or an equivalent tool to copy the files.
- Customized WinPE.wim image file from `c:\win2k8r2x64` to the `/opt/cnsaroot/Boot` folder.
  - Customized BCD file from `c:\NewBCDStore` to the `/opt/cnsaroot/Boot` folder (optional).
  - Customized install.wim image file from `c:\win2k8r2x64-iso\sources` to `/tmp` folder.
  - Windows 2008 R2 ISO image file into the `/tmp` folder.
- Step 2** Log on to the Bare Metal Agent VM using SSH client as 'root' user.
- Step 3** Change the folder to `/tmp`.
- Step 4** Mount the Windows 2008 R2 ISO image to the `/mnt` folder.  
`mount -o loop /tmp/(Windows-2008R2-ISO-Filename) /mnt`
- Step 5** Copy the Windows 2008 R2 install files to `/samba/Win2k8R2x64` folder.  
`cd /samba/Win2k8R2x64`  
`cp -r /mnt/*`
- Step 6** Verify that all the Windows 2008 R2 installation files are copied.
- Step 7** Move the install.wim image file from `/tmp` to `/samba/Win2k8R2x64/sources` folder.  
`mv /tmp/install.wim /samba/Win2k8R2x64/sources/`
- Step 8** Unmount the Windows 2008 R2 ISO image from the `/mnt` folder.  
`umount /mnt`
- Step 9** Open the `/samba/notifications/notify.ps1` file and verify that the IP address in the file matches that of the PXE IP address of Bare Metal Agent.
-

# Windows Server 2012 x64 and 2012 R2 x64 Operating System Images

Cisco UCS Director Bare Metal Agent supports PXE boot and installation operations for Windows 2012 x64 or 2012 R2 x64 OS images and PXE boot tasks used in bare metal provisioning workflows.

**Note**

If you need to support both Windows 2012 and 2012 R2, you must perform the image setup process twice, once for each OS. Although it is possible to set up a single WinPE file that supports multiple Windows OS versions, we recommend that you set up a separate WinPE file for each OS.

## Prerequisites for Setting Up Windows Server 2012 x64 and 2012 R2 x64 Operating System Images

Before you can install a Windows 2012 or 2012 R2 OS image in the `/opt/cnsaroot/Boot` directory of the Bare Metal Agent VM, you must install and set up the following prerequisites:

- Windows Assessment and Deployment Kit (Windows ADK, version 8.0 or later recommended, depending on the Windows version compatibilities with respect to the `WinPE.wim` file)
- A customized Windows Preinstallation Environment (`WinPE.wim`) and PXE supporting files
- Boot Configuration Data (BCD) file
- Windows installation files (the files extracted from the ISO)

**Note**

You do not need to manually create a Windows answer file when setting up Windows OS images. Bare Metal Agent builds the Windows answer file necessary to support your PXE Boot request, based on the information you provide when you create the PXE boot request.

To install and set up the images, download the following:

- Windows Assessment and Deployment Kit that supports Windows Server 2012 and Windows Server 2012 R2. For more information, see <http://technet.microsoft.com/en-us/library/dn613859.aspx>.
- Windows Server 2012 x64 and/or 2012 R2 x64 (Standard and Datacenter editions are required).

**Tip**

We recommend that you use the ISO download file, which contains all editions, including Standard, Enterprise, Datacenter, and Web. You can typically remove all editions except for Standard and Datacenter.

After the system image is in place, perform the following additional procedures:

- Set up WinPE and copy the supporting files to the Network Service Agent server for the PXE boot.
- Copy the Windows installation files to the server path.



# Creating a Custom WinPE and Copying the PXE Supported Files for Windows 2012



**Note** The `/opt/cnsaroot/Boot` folder is static, and each Bare Metal Agent can have only one boot folder.

## Before You Begin

Complete the prerequisites listed in [Prerequisites for Setting Up Windows Server 2012 x64 and 2012 R2 x64 Operating System Images](#), on page 46.

## Procedure

- Step 1** Download an ADK version that supports Windows 2012 and install it on a Windows 2012 machine.
- Note** When you specify the features to include in the download, you must include the Windows PE and Deployment Tools.
- Step 2** Navigate to the Windows Pre-installation Environment folder in the ADK tools and execute `copype.cmd` to create the files that WinPE requires.
- ```
Copype.cmd amd64 C:\WinPE_amd64
```
- The target directory contains the `WinPE.wim` file. The latest ADK versions create a `boot.vim` file, which needs to be renamed to `WinPE.wim`.
- Step 3** In the Windows machine that has the ADK tools installed, create a directory. Copy the `WinPE.wim` file from `/opt/cnsaroot/Boot` to the directory you have created.
- Step 4** At the command line, navigate to the ADK installed folder.
- Step 5** Add the drivers from their folder locations to the WinPE image.
Use the following `DISM.exe` command when you know the paths to the drivers that you want to add.

```
// The DISM.exe command mounts the WinPE to a folder.
// In this example, the c:\win2k12x64 directory and the \mount subdirectory have been created
// before running the command.
DISM.exe /mount-wim /wimfile:c:\win2k12x64\WinPE.wim /index:1 /mountdir:c:\win2k12x64\mount

// To add individual driver files to WinPE image, use the following format.
DISM.exe /image:c:\win2k12x64\mount /Add-Driver /driver:C:\test\drivers\1.inf
/driver:C:\test\drivers\2.inf /driver:C:\test\drivers\3.inf
```

Use the following `DISM.exe` command when you do not know the paths to the drivers that you want to add and need to query all subfolders.

```
// The DISM.exe command mounts the WinPE to a folder.
// In this example, the c:\win2k12x64 directory and the \mount subdirectory have been created
// before running the command.
DISM.exe /mount-wim /wimfile:c:\win2k12x64\WinPE.wim /index:1 /mountdir:c:\win2k12x64\mount
```

```
// To add individual driver files to WinPE image, use the following format.
DISM.exe /image:c:\win2k12x64\mount /Add-Driver /driver:c:\test\drivers /Recurse
```

Step 6 Mount WinPE.wim to a folder.

Step 7 In WinPE.wim, add the required PowerShell packages and edit the paths in each command with the correct mount point and ADK installation path for your environment.

Note The PowerShell packages and file names that you need to add to WinPE.wim are dependent upon the version of Windows and WinPE.wim. To determine which PowerShell packages you need to add, see the compliance report on the Microsoft website. For information about the commands to add the necessary packages for PowerShell, see the [WinPE: Adding PowerShell support to Windows PE Technet Page](#). The PowerShell package files shown below are provided for reference and will vary depending on the version of Windows and WinPE.wim.

```
\\ Sample PowerShell package files.
\\ The PowerShell packages and file names that you need to add to WinPE.wim vary depending
on the version of Windows and WinPE.wim.
```

```
Dism /Add-Package /Image:"C:\win2k12x64\mount" /PackagePath:"C:\Program Files\Windows
Kits\8.1\Assessment and Deployment Kit\Windows Preinstallation
Environment\amd64\WinPE_OC\WinPE-WMI.cab"
```

```
Dism /Add-Package /Image:"C:\win2k12x64\mount" /PackagePath:"C:\Program Files\Windows
Kits\8.1\Assessment and Deployment Kit\Windows Preinstallation
Environment\amd64\WinPE_OC\en-us\WinPE-WMI_en-us.cab"
```

```
Dism /Add-Package /Image:"C:\win2k12x64\mount" /PackagePath:"C:\Program Files\Windows
Kits\8.1\Assessment and Deployment Kit\Windows Preinstallation
Environment\amd64\WinPE_OC\WinPE-NetFX.cab"
```

```
Dism /Add-Package /Image:"C:\win2k12x64\mount" /PackagePath:"C:\Program Files\Windows
Kits\8.1\Assessment and Deployment Kit\Windows Preinstallation
Environment\amd64\WinPE_OC\en-us\WinPE-NetFX_en-us.cab"
```

```
Dism /Add-Package /Image:"C:\win2k12x64\mount" /PackagePath:"C:\Program Files\Windows
Kits\8.1\Assessment and Deployment Kit\Windows Preinstallation
Environment\amd64\WinPE_OC\WinPE-Scripting.cab"
```

```
Dism /Add-Package /Image:"C:\win2k12x64\mount" /PackagePath:"C:\Program Files\Windows
Kits\8.1\Assessment and Deployment Kit\Windows Preinstallation
Environment\amd64\WinPE_OC\en-us\WinPE-Scripting_en-us.cab"
```

```
Dism /Add-Package /Image:"C:\win2k12x64\mount" /PackagePath:"C:\Program Files\Windows
Kits\8.1\Assessment and Deployment Kit\Windows Preinstallation
Environment\amd64\WinPE_OC\WinPE-PowerShell.cab"
```

```
Dism /Add-Package /Image:"C:\win2k12x64\mount" /PackagePath:"C:\Program Files\Windows
Kits\8.1\Assessment and Deployment Kit\Windows Preinstallation
Environment\amd64\WinPE_OC\en-us\WinPE-PowerShell_en-us.cab"
```

```
Dism /Add-Package /Image:"C:\win2k12x64\mount" /PackagePath:"C:\Program Files\Windows
Kits\8.1\Assessment and Deployment Kit\Windows Preinstallation
Environment\amd64\WinPE_OC\WinPE-StorageWMI.cab"
```

```
Dism /Add-Package /Image:"C:\win2k12x64\mount" /PackagePath:"C:\Program Files\Windows Kits\8.1\Assessment and Deployment Kit\Windows Preinstallation Environment\amd64\WinPE_OCs\en-us\WinPE-StorageWMI_en-us.cab"
```

```
Dism /Add-Package /Image:"C:\win2k12x64\mount" /PackagePath:"C:\Program Files\Windows Kits\8.1\Assessment and Deployment Kit\Windows Preinstallation Environment\amd64\WinPE_OCs\WinPE-DismCmdlets.cab"
```

```
Dism /Add-Package /Image:"C:\win2k12x64\mount" /PackagePath:"C:\Program Files\Windows Kits\8.1\Assessment and Deployment Kit\Windows Preinstallation Environment\amd64\WinPE_OCs\en-us\WinPE-DismCmdlets_en-us.cab"
```

Step 8 Navigate to `\windows\system32` in the mount folder. In the `startnet.cmd`, update the IP address for Bare Metal Agent.

- Note**
- Do not change any information in the `startnet.cmd` file, except for the Bare Metal Agent IP address.
 - Make sure that you modify the IP addresses in all the entries so that they point to the Bare Metal Agent IP address.
 - All drive letter references (such as the reference to an R: drive) must match in both the `startnet.cmd` file and the Windows answer file. By default, Bare Metal Agent comes with an R: drive letter assignment.

Step 9 Unmount the WinPE, commit the changes, and copy the file to the `/opt/cnsaroot/Boot` directory in the Bare Metal Agent VM.

```
DISM.exe /Unmount-Wim /Mountdir:c:\win2k12x64\mount /commit
```

What to Do Next

Install and set up (as necessary) the Boot Configuration Data (BCD) file.

Creating a Custom WinPE and Copying the PXE Supported Files for Windows 2012 R2

For Windows Server 2012 R2 x64, Bare Metal Agent provides the WinPE and supported PXE files. You need only add any required drivers to the `WinPE.wim` file, and then edit the `WinPE.wim` file to change the IP address in the `startnet.cmd` file to the PXE IP address for your Bare Metal Agent.



Note

The `/opt/cnsaroot/Boot` folder is static, and each Bare Metal Agent can have only one boot folder.

Before You Begin

Complete the prerequisites listed in [Prerequisites for Setting Up Windows Server 2012 x64 and 2012 R2 x64 Operating System Images](#), on page 46.

Procedure

- Step 1** Download an ADK version that supports Windows 2012 R2 and install it on a Windows 2012 R2 machine.
- Note** When you specify the features to include in the download, you must include the Windows PE and Deployment Tools.
- Step 2** In the Windows machine that has the ADK tools installed, create a directory. Copy the WinPE.wim file from /opt/cnsaroot/Boot to the directory you created.
- Step 3** At the command line, navigate to the ADK installed folder.
- Step 4** Add the drivers from their folder locations to the WinPE image.
Use the following DISM.exe command when you know the paths to the drivers that you want to add.

```
// The DISM.exe command mounts the WinPE to a folder.
// In this example, the c:\win2k12r2x64 directory and the \mount subdirectory have been
created before running the command.
DISM.exe /mount-wim /wimfile:c:\win2k12r2x64\WinPE.wim /index:1
/mountdir:c:\win2k12r2x64\mount
```

```
// To add individual driver files to WinPE image, use the following format.
DISM.exe /image:c:\win2k12r2x64\mount /Add-Driver /driver:C:\test\drivers\1.inf
/driver:C:\test\drivers\2.inf /driver:C:\test\drivers\3.inf
```

Use the following DISM.exe command when you do not know the paths to the drivers that you want to add and need to query all subfolders.

```
// The DISM.exe command mounts the WinPE to a folder.
// In this example, the c:\win2k12r2x64 directory and the \mount subdirectory have been
created before running the command.
DISM.exe /mount-wim /wimfile:c:\win2k12r2x64\WinPE.wim /index:1
/mountdir:c:\win2k12r2x64\mount
```

```
// To add individual driver files to WinPE image, use the following format.
DISM.exe /image:c:\win2k12r2x64\mount /Add-Driver /driver:c:\test\drivers /Recurse
```

- Step 5** Mount winPE.wim to a folder.
- Step 6** In WinPE.wim, add the required PowerShell packages and edit the paths in each command with the correct mount point and ADK installation path for your environment.
- Note** The PowerShell packages and file names that you need to add to WinPE.wim are dependent on the version of Windows and WinPE.wim. To determine which PowerShell packages you need to add, see the compliance report on the Microsoft website. For information about the commands to add the necessary packages for PowerShell, see the [WinPE: Adding PowerShell support to Windows PE Technet Page](#). The PowerShell package files shown below are provided for reference and will vary depending on the version of Windows and WinPE.wim.

```
\\ Sample PowerShell package files.
\\ The PowerShell packages and file names that you need to add to WinPE.wim vary depending
on the version of Windows and WinPE.wim.
```

```
Dism /Add-Package /Image:"C:\win2k12r2x64\mount" /PackagePath:"C:\Program Files\Windows
Kits\8.1\Assessment and Deployment Kit\Windows Preinstallation
Environment\amd64\WinPE_OC\WinPE-WMI.cab"
```

```

Dism /Add-Package /Image:"C:\win2k12r2x64\mount" /PackagePath:"C:\Program Files\Windows Kits\8.1\Assessment and Deployment Kit\Windows Preinstallation Environment\amd64\WinPE_OC\en-us\WinPE-WMI_en-us.cab"

```

```

Dism /Add-Package /Image:"C:\win2k12r2x64\mount" /PackagePath:"C:\Program Files\Windows Kits\8.1\Assessment and Deployment Kit\Windows Preinstallation Environment\amd64\WinPE_OC\WinPE-NetFX.cab"

```

```

Dism /Add-Package /Image:"C:\win2k12r2x64\mount" /PackagePath:"C:\Program Files\Windows Kits\8.1\Assessment and Deployment Kit\Windows Preinstallation Environment\amd64\WinPE_OC\en-us\WinPE-NetFX_en-us.cab"

```

```

Dism /Add-Package /Image:"C:\win2k12r2x64\mount" /PackagePath:"C:\Program Files\Windows Kits\8.1\Assessment and Deployment Kit\Windows Preinstallation Environment\amd64\WinPE_OC\WinPE-Scripting.cab"

```

```

Dism /Add-Package /Image:"C:\win2k12r2x64\mount" /PackagePath:"C:\Program Files\Windows Kits\8.1\Assessment and Deployment Kit\Windows Preinstallation Environment\amd64\WinPE_OC\en-us\WinPE-Scripting_en-us.cab"

```

```

Dism /Add-Package /Image:"C:\win2k12r2x64\mount" /PackagePath:"C:\Program Files\Windows Kits\8.1\Assessment and Deployment Kit\Windows Preinstallation Environment\amd64\WinPE_OC\WinPE-PowerShell.cab"

```

```

Dism /Add-Package /Image:"C:\win2k12r2x64\mount" /PackagePath:"C:\Program Files\Windows Kits\8.1\Assessment and Deployment Kit\Windows Preinstallation Environment\amd64\WinPE_OC\en-us\WinPE-PowerShell_en-us.cab"

```

```

Dism /Add-Package /Image:"C:\win2k12r2x64\mount" /PackagePath:"C:\Program Files\Windows Kits\8.1\Assessment and Deployment Kit\Windows Preinstallation Environment\amd64\WinPE_OC\WinPE-StorageWMI.cab"

```

```

Dism /Add-Package /Image:"C:\win2k12r2x64\mount" /PackagePath:"C:\Program Files\Windows Kits\8.1\Assessment and Deployment Kit\Windows Preinstallation Environment\amd64\WinPE_OC\en-us\WinPE-StorageWMI_en-us.cab"

```

```

Dism /Add-Package /Image:"C:\win2k12r2x64\mount" /PackagePath:"C:\Program Files\Windows Kits\8.1\Assessment and Deployment Kit\Windows Preinstallation Environment\amd64\WinPE_OC\WinPE-DismCmdlets.cab"

```

```

Dism /Add-Package /Image:"C:\win2k12r2x64\mount" /PackagePath:"C:\Program Files\Windows Kits\8.1\Assessment and Deployment Kit\Windows Preinstallation Environment\amd64\WinPE_OC\en-us\WinPE-DismCmdlets_en-us.cab"

```

Step 7 Navigate to `\windows\system32` in the mount folder. In the `startnet.cmd`, update the IP address for Bare Metal Agent.

- Note**
- Do not change any information in the `startnet.cmd` file, except the IP address for Bare Metal Agent.
 - Make sure that you modify the IP address in all the entries so that they point to the Bare Metal Agent IP address.
 - All drive letter references (such as the reference to an R: drive) must match in both the `startnet.cmd` file and the Windows answer file. By default, Bare Metal Agent comes with an R: drive letter assignment.

- Step 8** Unmount the WinPE, commit the changes, and copy the file to the `/opt/cnsaroot/Boot` directory in the Bare Metal Agent VM.

```
DISM.exe /Unmount-Wim /Mountdir:c:\win2k12r2x64\mount /commit
```

What to Do Next

Install and set up (as necessary) the Boot Configuration Data (BCD) file.

Installing and Setting Up the Boot Configuration Data File

The Boot Configuration Data (BCD) file contains the boot configuration parameters. It controls how the operating system is started in Windows and is used to load the base kernel (WinPE.wim) from the PXE server. You do not need to create a BCD file. Bare Metal Agent provides a BCD file with default paths that you can use.

By default, the BCD file points to the `/Boot/WinPE.wim` and `boot.sdi` files. These filenames are case sensitive.



Note

We recommend that you use a set of standard names for Bare Metal Agent configuration purposes. The folder name should be `Boot`. The `winpe` file name should be `WinPE.wim`. Use corresponding filenames such as `boot.sdi`. The created BCD file should be in uppercase, and this file will not have any file extension. Bare Metal Agent delivers the BCD file to `/opt/cnsaroot/Boot`, which contains a default path pointing to `/opt/cnsaroot/Boot/WinPE.wim`. This file can be used by any Windows OS version, unless you change the path names.

The command **bcdedit.exe** used to create BCD files is commonly available in the Windows operating systems root directory: `c:\windows\system32`.

Before You Begin

Create a custom WinPE and copy the PXE supported files

Procedure

- Step 1** Navigate to the directory that contains the **bcdedit.exe** command and run the following sequence of commands to create the BCD file.
The **bcdedit.exe** command is commonly available in the Windows operating systems root directory:
`c:\windows\system32`.
- Step 2** **bcdedit.exe /createstore BCD**
- Step 3** **bcdedit.exe /store BCD /create {ramdiskoptions} /d "Ramdisk options"**
- Step 4** **bcdedit.exe /store BCD /set {ramdiskoptions} ramdiskdevice boot**
- Step 5** **bcdedit.exe /store BCD /set {ramdiskoptions} ramdiskpath \Boot\boot.sdi**
- Step 6** **bcdedit.exe /store BCD /create /d "My WinPE Boot Image" /application osloader**
At this point, the GUID is displayed. Replace `{a20f8db8-7459-11e2-8ec3-00155d37efa7}` in the following steps with the GUID from your system.

- Step 7** `bcdedit.exe /store BCD /set {a20f8db8-7459-11e2-8ec3-00155d37efa7} systemroot \Windows`
- Step 8** `bcdedit.exe /store BCD /set {a20f8db8-7459-11e2-8ec3-00155d37efa7} detecthal Yes`
- Step 9** `bcdedit.exe /store BCD /set {a20f8db8-7459-11e2-8ec3-00155d37efa7} winpe Yes`
- Step 10** `bcdedit.exe /store BCD /set {a20f8db8-7459-11e2-8ec3-00155d37efa7} osdevice
ramdisk=[boot]\Boot\WinPE.wim,{ramdiskoptions}`
- Step 11** `bcdedit.exe /store BCD /set {a20f8db8-7459-11e2-8ec3-00155d37efa7} device
ramdisk=[boot]\Boot\WinPE.wim,{ramdiskoptions}`
- Step 12** One of the following:
- `bcdedit.exe /store BCD /create {bootmgr} /d "Windows 2012r2 BootManager"`
 - `bcdedit.exe /store BCD /create {bootmgr} /d "Windows 2012 BootManager"`
- Step 13** `bcdedit.exe /store BCD /set {bootmgr} timeout 30`
- Step 14** `bcdedit.exe /store BCD /displayorder {a20f8db8-7459-11e2-8ec3-00155d37efa7}`
- Step 15** Use the following command to verify that the configuration names are correct: `bcdedit.exe /store BCD /enum all`

What to Do Next

Copy the Windows installation ISO image to the server folder.

Copying the Windows Installation Files to the Server Folder

Before You Begin

You must have the following in place:

- Customized `winPE.wim` and PXE boot files in the `opt/cnsaroot/Boot` directory in the Bare Metal Agent VM.
- Configured BCD file in the `/opt/cnsaroot/Boot` directory in the Bare Metal Agent VM.
- Windows installation files (ISO version).

Procedure

- Step 1** Extract the downloaded ISO that you obtained and validated.
- Step 2** Copy the folders and files from the downloaded ISO to the appropriate directory in the Bare Metal Agent VM.

Windows OS Version	Server Path
Windows 2012 R2	<code>/samba/Win2k12R2x64</code>
Windows 2012	<code>/samba/Win2k12x64</code>

Note Do not change the folder paths, filenames, or folder names.

The following is a sample of the contents of a `Win2k12R2x64` folder after the Windows installation files have been copied to it:

```
boot
efi
sources
support
autorun.inf
bootmgr.efi
setup.exe
```

Step 3 Open the `/samba/notifications/notify.ps1` file and verify that the IP address matches the PXE IP address of Bare Metal Agent.

Windows Server 2016 x64 Operating System Images

Cisco UCS Director Bare Metal Agent supports PXE boot and installation operations for Windows 2016 x64 OS images and PXE boot tasks used in bare metal provisioning workflows.

Prerequisites for Setting Up Windows Server 2016 x64 Operating System Images

Before you can install a Windows 2016 OS image in the `/opt/cnsaroot/Boot` directory of the Bare Metal Agent VM, you must install and set up the following prerequisites:

- Windows Assessment and Deployment Kit (Windows ADK, version 8.0 or later recommended, depending on the Windows version compatibilities with respect to the `WinPE.wim` file)
- A customized Windows Preinstallation Environment (`WinPE.wim`) and PXE supporting files
- Boot Configuration Data (BCD) file
- Windows installation files (the files extracted from the ISO)



Note

You do not need to manually create a Windows answer file when setting up Windows OS images. Bare Metal Agent builds the Windows answer file necessary to support your PXE Boot request, based on the information you provide when you create the PXE boot request.

To install and set up the images, download the following:

- Windows Assessment and Deployment Kit that supports Windows Server 2016. For more information, see <http://technet.microsoft.com/en-us/library/dn613859.aspx>.
- Windows Server 2016 x64.

**Tip**

We recommend that you use the ISO download file, which contains all editions, including Standard, Enterprise, Datacenter, and Web. You can typically remove all editions except for Standard and Datacenter.

After the system image is in place, perform the following additional procedures:

- Set up WinPE and copy the supporting files to the Network Service Agent server for the PXE boot.
- Copy the Windows installation files to the server path.

Creating a Custom WinPE and Copying the PXE Supported Files for Windows 2016

**Note**

The `/opt/cnsaroot/Boot` folder is static, and each Bare Metal Agent can have only one boot folder.

Before You Begin

Complete the prerequisites listed in [Prerequisites for Setting Up Windows Server 2016 x64 Operating System Images](#), on page 54.

Procedure

- Step 1** Download an ADK version that supports Windows 2016 and install it on a Windows 2016 machine.
- Note** When you specify the features to include in the download, you must include the Windows PE and Deployment Tools.
- Step 2** Navigate to the Windows Pre-installation Environment folder in the ADK tools and execute `copype.cmd` to create the files that WinPE requires.
- ```
Copype.cmd amd64 C:\WinPE_amd64
```
- The target directory contains the `WinPE.wim` file. The latest ADK versions create a `boot.vim` file, which needs to be renamed to `WinPE.wim`.
- Step 3** In the Windows machine that has the ADK tools installed, create a directory. Copy the `WinPE.wim` file from `/opt/cnsaroot/Boot` to the directory you have created.
- Step 4** At the command line, navigate to the ADK installed folder.
- Step 5** Add the drivers from their folder locations to the WinPE image. Use the following `DISM.exe` command when you know the paths to the drivers that you want to add.

```
// The DISM.exe command mounts the WinPE to a folder.
// In this example, the c:\win2k16x64 directory and the \mount subdirectory have been created
// before running the command.
DISM.exe /mount-wim /wimfile:c:\win2k16x64\WinPE.wim /index:1 /mountdir:c:\win2k16x64\mount
```

```
// To add individual driver files to WinPE image, use the following format.
DISM.exe /image:c:\win2k16x64\mount /Add-Driver /driver:C:\test\drivers\1.inf
```

```
/driver:C:\test\drivers\2.inf /driver:C:\test\drivers\3.inf
```

Use the following DISM.exe command when you do not know the paths to the drivers that you want to add and need to query all subfolders.

```
// The DISM.exe command mounts the WinPE to a folder.
// In this example, the c:\win2k16x64 directory and the \mount subdirectory have been created
before running the command.
DISM.exe /mount-wim /wimfile:c:\win2k16x64\WinPE.wim /index:1 /mountdir:c:\win2k16x64\mount

// To add individual driver files to WinPE image, use the following format.
DISM.exe /image:c:\win2k16x64\mount /Add-Driver /driver:c:\test\drivers /Recurse
```

**Step 6** Mount WinPE.wim to a folder.

**Step 7** In WinPE.wim, add the required PowerShell packages and edit the paths in each command with the correct mount point and ADK installation path for your environment.

**Note** The PowerShell packages and file names that you need to add to WinPE.wim are dependent upon the version of Windows and WinPE.wim. To determine which PowerShell packages you need to add, see the compliance report on the Microsoft website. For information about the commands to add the necessary packages for PowerShell, see the [WinPE: Adding PowerShell support to Windows PE Technet Page](#). The PowerShell package files shown below are provided for reference and will vary depending on the version of Windows and WinPE.wim.

```
\\ Sample PowerShell package files.
\\ The PowerShell packages and file names that you need to add to WinPE.wim vary depending
on the version of Windows and WinPE.wim.

Dism /Add-Package /Image:"C:\win2k16x64\mount" /PackagePath:"C:\Program Files\Windows
Kits\10\Assessment and Deployment Kit\Windows Preinstallation
Environment\amd64\WinPE_OC\WinPE-WMI.cab"

Dism /Add-Package /Image:"C:\win2k16x64\mount" /PackagePath:"C:\Program Files\Windows
Kits\10\Assessment and Deployment Kit\Windows Preinstallation
Environment\amd64\WinPE_OC\en-us\WinPE-WMI_en-us.cab"

Dism /Add-Package /Image:"C:\win2k16x64\mount" /PackagePath:"C:\Program Files\Windows
Kits\10\Assessment and Deployment Kit\Windows Preinstallation
Environment\amd64\WinPE_OC\WinPE-NetFX.cab"

Dism /Add-Package /Image:"C:\win2k16x64\mount" /PackagePath:"C:\Program Files\Windows
Kits\10\Assessment and Deployment Kit\Windows Preinstallation
Environment\amd64\WinPE_OC\en-us\WinPE-NetFX_en-us.cab"

Dism /Add-Package /Image:"C:\win2k16x64\mount" /PackagePath:"C:\Program Files\Windows
Kits\10\Assessment and Deployment Kit\Windows Preinstallation
Environment\amd64\WinPE_OC\WinPE-Scripting.cab"

Dism /Add-Package /Image:"C:\win2k16x64\mount" /PackagePath:"C:\Program Files\Windows
Kits\10\Assessment and Deployment Kit\Windows Preinstallation
Environment\amd64\WinPE_OC\en-us\WinPE-Scripting_en-us.cab"

Dism /Add-Package /Image:"C:\win2k16x64\mount" /PackagePath:"C:\Program Files\Windows
Kits\10\Assessment and Deployment Kit\Windows Preinstallation
```

```
Environment\amd64\WinPE_OC\WinPE-PowerShell.cab"
```

```
DISM /Add-Package /Image:"C:\win2k16x64\mount" /PackagePath:"C:\Program Files\Windows Kits\10\Assessment and Deployment Kit\Windows Preinstallation Environment\amd64\WinPE_OC\en-us\WinPE-PowerShell_en-us.cab"
```

```
DISM /Add-Package /Image:"C:\win2k16x64\mount" /PackagePath:"C:\Program Files\Windows Kits\10\Assessment and Deployment Kit\Windows Preinstallation Environment\amd64\WinPE_OC\WinPE-StorageWMI.cab"
```

```
DISM /Add-Package /Image:"C:\win2k16x64\mount" /PackagePath:"C:\Program Files\Windows Kits\10\Assessment and Deployment Kit\Windows Preinstallation Environment\amd64\WinPE_OC\en-us\WinPE-StorageWMI_en-us.cab"
```

```
DISM /Add-Package /Image:"C:\win2k16x64\mount" /PackagePath:"C:\Program Files\Windows Kits\10\Assessment and Deployment Kit\Windows Preinstallation Environment\amd64\WinPE_OC\WinPE-DismCmdlets.cab"
```

```
DISM /Add-Package /Image:"C:\win2k16x64\mount" /PackagePath:"C:\Program Files\Windows Kits\10\Assessment and Deployment Kit\Windows Preinstallation Environment\amd64\WinPE_OC\en-us\WinPE-DismCmdlets_en-us.cab"
```

**Step 8** Navigate to `\windows\system32` in the mount folder. In the `startnet.cmd`, update the IP address for Bare Metal Agent.

- Note**
- Do not change any information in the `startnet.cmd` file, except for the Bare Metal Agent IP address.
  - Make sure that you modify the IP addresses in all the entries so that they point to the Bare Metal Agent IP address.
  - All drive letter references (such as the reference to an R: drive) must match in both the `startnet.cmd` file and the Windows answer file. By default, Bare Metal Agent comes with an R: drive letter assignment.

**Step 9** Unmount the WinPE, commit the changes, and copy the file to the `/opt/cnsaroot/Boot` directory in the Bare Metal Agent VM.

```
DISM.exe /Unmount-Wim /Mountdir:c:\win2k16x64\mount /commit
```

### What to Do Next

Install and set up (as necessary) the Boot Configuration Data (BCD) file.

## Installing and Setting Up the Boot Configuration Data File

The Boot Configuration Data (BCD) file contains the boot configuration parameters. It controls how the operating system is started in Windows and is used to load the base kernel (WinPE.wim) from the PXE server. You do not need to create a BCD file. Bare Metal Agent provides a BCD file with default paths that you can use.

By default, the BCD file points to the `/Boot/WinPE.wim` and `boot.sdi` files. These filenames are case sensitive.

**Note**

We recommend that you use a set of standard names for Bare Metal Agent configuration purposes. The folder name should be `Boot`. The `winpe` file name should be `WinPE.wim`. Use corresponding filenames such as `boot.sdi`. The created BCD file should be in uppercase, and this file will not have any file extension. Bare Metal Agent delivers the BCD file to `/opt/cnsaroot/Boot`, which contains a default path pointing to `/opt/cnsaroot/Boot/WinPE.wim`. This file can be used by any Windows OS version, unless you change the path names.

The command **bcdedit.exe** used to create BCD files is commonly available in the Windows operating systems root directory: `c:\windows\system32`.

**Before You Begin**

Create a custom WinPE and copy the PXE supported files

**Procedure**

**Step 1** Navigate to the directory that contains the **bcdedit.exe** command and run the following sequence of commands to create the BCD file.

The **bcdedit.exe** command is commonly available in the Windows operating systems root directory:  
`c:\windows\system32`.

**Step 2** **bcdedit.exe /createstore BCD**

**Step 3** **bcdedit.exe /store BCD /create {ramdiskoptions} /d "Ramdisk options"**

**Step 4** **bcdedit.exe /store BCD /set {ramdiskoptions} ramdiskdevice boot**

**Step 5** **bcdedit.exe /store BCD /set {ramdiskoptions} ramdiskdipath \Boot\boot.sdi**

**Step 6** **bcdedit.exe /store BCD /create /d "My WinPE Boot Image" /application osloader**

At this point, the GUID is displayed. Replace `{a20f8db8-7459-11e2-8ec3-00155d37efa7}` in the following steps with the GUID from your system.

**Step 7** **bcdedit.exe /store BCD /set {a20f8db8-7459-11e2-8ec3-00155d37efa7} systemroot \Windows**

**Step 8** **bcdedit.exe /store BCD /set {a20f8db8-7459-11e2-8ec3-00155d37efa7} detecthal Yes**

**Step 9** **bcdedit.exe /store BCD /set {a20f8db8-7459-11e2-8ec3-00155d37efa7} winpe Yes**

**Step 10** **bcdedit.exe /store BCD /set {a20f8db8-7459-11e2-8ec3-00155d37efa7} osdevice  
ramdisk=[boot]\Boot\WinPE.wim,{ramdiskoptions}**

**Step 11** **bcdedit.exe /store BCD /set {a20f8db8-7459-11e2-8ec3-00155d37efa7} device  
ramdisk=[boot]\Boot\WinPE.wim,{ramdiskoptions}**

**Step 12** **bcdedit.exe /store BCD /create {bootmgr} /d "Windows 2016 BootManager"**

**Step 13** **bcdedit.exe /store BCD /set {bootmgr} timeout 30**

**Step 14** **bcdedit.exe /store BCD /displayorder {a20f8db8-7459-11e2-8ec3-00155d37efa7}**

**Step 15** Use the following command to verify that the configuration names are correct: **bcdedit.exe /store BCD /enum  
all**

**What to Do Next**

Copy the Windows installation ISO image to the server folder.

## Copying the Windows Installation Files to the Server Folder

### Before You Begin

You must have the following in place:

- Customized winPE.wim and PXE boot files in the `opt/cnsaroot/Boot` directory in the Bare Metal Agent VM.
- Configured BCD file in the `/opt/cnsaroot/Boot` directory in the Bare Metal Agent VM.
- Windows installation files (ISO version).

### Procedure

- 
- Step 1** Extract the downloaded ISO that you obtained and validated.
- Step 2** Copy the folders and files from the downloaded ISO to the appropriate directory in the Bare Metal Agent VM.

| Windows OS Version | Server Path                    |
|--------------------|--------------------------------|
| Windows 2016       | <code>/samba/Win2k16x64</code> |

**Note** Do not change the folder paths, filenames, or folder names.

The following is a sample of the contents of a `Win2k16x64` folder after the Windows installation files have been copied to it:

```
boot
efi
sources
support
autorun.inf
bootmgr.efi
setup.exe
```

- Step 3** Open the `/samba/notifications/notify.ps1` file and verify that the IP address matches the PXE IP address of Bare Metal Agent.
- 

## Using MEMDISK for Deploying Multiple Versions of Windows Simultaneously

Currently, Bare Metal Agent adopts the Microsoft Windows PXE boot process, which expects WinPE.wim to be placed in the `/tftpboot/Boot` folder. This process results in maintaining a single WinPE for deploying multiple versions of Windows simultaneously from Bare Metal Agent. To use different WinPE files for deploying different versions of Windows simultaneously, you have to rename each WinPE.wim file manually

according to the BCD file. To overcome this limitation, you can use MEMDISK to boot the ISO file. The MEMDISK file is available in the `/opt/cnsaroot` folder in Bare Metal Agent, as part of syslinux. When you use MEMDISK, the ISO file can be placed anywhere in the TFTP root directory in Bare Metal Agent.

## Requirements for Using MEMDISK

To use MEMDISK in Bare Metal Agent, create a bootable WINPE ISO file and then modify the MAC file template.

### Creating Bootable WINPE File for Windows Server 2008 R2, 2012, 2012 R2, or 2016

#### Before You Begin

Install Windows Assessment and Deployment Kit (Windows ADK) that is compatible with the Windows Server version you want to deploy.

#### Procedure

---

**Step 1** Launch the Deployment and Imaging Tools Environment.

**Step 2** Create a new WinPE environment folder:

```
Copyype.cmd amd64 C:\WinPE_amd64
```

The 'copyype.cmd' command creates a "WinPE\_amd64" folder with three subfolders: fwfiles, media and mount. The folders created are based on the ADK version.

**Step 3** Delete bootfix.bin from `/media/Boot` folder.

Deleting bootfix.bin helps you avoid pressing a key to boot the ISO if any partition is detected on the hard disk drive.

**Step 4** Create the customized WinPE.wim (available in the `/media/Sources` folder) by making the following changes:

- a) Inject PowerShell packages.
- b) Inject drivers (if any)
- c) Edit Startnet.cmd.

For injecting PowerShell packages and editing Startnet.cmd for the Windows Server version you are deploying, see

- [Customizing and Copying the WinPE.wim and PXE Boot Files for Windows 2008 R2, on page 42](#)
- [Creating a Custom WinPE and Copying the PXE Supported Files for Windows 2012, on page 47](#)
- [Creating a Custom WinPE and Copying the PXE Supported Files for Windows 2012 R2, on page 49](#)

**Step 5** Execute the following command from the terminal to create the bootable WINPE ISO file:

```
Makewinpe media /iso C:\WinPE_amd64 C:\WinPE_amd64.iso
```

---

## Modifying MAC File Template

To support the MEMDISK boot process in Bare Metal Agent, the MAC file template has to be modified. The `/opt/cnsaroot/templates` folder in Bare Metal Agent has the configuration files templates for all the three versions of Windows.

**Note**

As the MAC template file is static, you can either implement the Windows PXE boot process or the MEMDISK boot process. You cannot implement both of them.

**Procedure**

|               | Command or Action                                                                                                                                                                                                                                                                                                                                                                                                                                                           | Purpose |
|---------------|-----------------------------------------------------------------------------------------------------------------------------------------------------------------------------------------------------------------------------------------------------------------------------------------------------------------------------------------------------------------------------------------------------------------------------------------------------------------------------|---------|
| <b>Step 1</b> | After creating the bootable WINPE ISO file, create a folder called 'windows' under <code>/opt/cnsaroot</code> (folder name is not static) in the BMA tftp root directory.                                                                                                                                                                                                                                                                                                   |         |
| <b>Step 2</b> | Copy the working bootable WINPE ISO file to the windows folder.                                                                                                                                                                                                                                                                                                                                                                                                             |         |
| <b>Step 3</b> | When the MEMDISK module is loaded, it adds the ISO image to the memory (specified as INITRD in the MAC File).                                                                                                                                                                                                                                                                                                                                                               |         |
| <b>Step 4</b> | <p>Pass the two parameters, iso and raw, to MEMDISK using APPEND. (This instructs MEMDISK to load an ISO image and enter in protected mode directly).</p> <p><b>Example:</b><br/>For example, if you want to boot Windows Server 2012 R2 using MEMDISK, make the following changes in <code>pxe.cfg</code> available in the <code>Win2k12R2x64</code> folder:</p> <pre>default 1 timeout 100 prompt 1 label 1 KERNEL memdisk INITRD /windows/WinPE.iso APPEND iso raw</pre> |         |







## CHAPTER 8

# Provisioning OS Images through Orchestration Workflow Tasks

---

This chapter contains the following sections:

- [Orchestration Workflow Tasks for PXE Boot](#), page 63
- [Prerequisites for Workflows with PXE Boot Tasks](#), page 64
- [Execution of the Setup PXE Boot Tasks](#), page 65
- [Determining the Windows OS Edition](#), page 66
- [Inputs for the Setup PXE Boot Task](#), page 67
- [Inputs for the Setup PXE Boot with BMA Selection Task](#), page 70
- [Inputs for the Setup Windows PXE Boot Task](#), page 73
- [Outputs from the Setup PXE Boot Task and Setup Windows PXE Boot Task](#), page 76
- [Creating a PXE Boot Request in Cisco UCS Director](#), page 76
- [Viewing the PXE Request Configuration Files](#), page 80
- [PXE Boot States](#), page 80
- [Monitor PXE Boot Setup Task](#), page 81
- [Remove PXE Boot Setup Task](#), page 81
- [Injecting Drivers When Installing RHEL 7 or CentOS 7 on UCS Modular Servers](#), page 82
- [Simultaneous Provisioning of Windows Server Operating Systems](#), page 83

## Orchestration Workflow Tasks for PXE Boot

The orchestration workflow tasks for PXE boot enable you to create workflows within Cisco UCS Director that use the functionality of Cisco UCS Director Bare Metal Agent.

When you include any of the PXE boot tasks in an orchestration workflow, the task prepares the Bare Metal Agent environment to receive a PXE install request for a physical or virtual machine.

The values for each input required within the task can be supplied in one of the following ways:

- As user inputs by the user who executes the workflow
- Through outputs from a previous task in the workflow
- Through admin inputs that are assigned by the Cisco UCS Director user who creates the workflow

The following orchestration workflow tasks are available:

- Setup PXE Boot task
- Setup PXE Boot with BMA Selection task
- Setup Windows PXE Boot task
- Monitor PXE Boot task
- Remove PXE Boot Setup task



**Note**

To set up a PXE boot for a Windows Server operating system, you must use the PXE boot setup task that is defined specifically for Windows. To set up a PXE boot for all other supported operating systems, use the Setup PXE Boot task or the Setup PXE Boot with BMA Selection task.

You can access these workflow tasks in the **Network Services** area of the Cisco UCS Director Workflow Designer Task Library.

Most inputs and outputs are the same for the Setup PXE Boot task, the Setup PXE Boot with BMA Selection task, and the Setup Windows PXE Boot task, with the following notable exceptions:

- The Setup PXE Boot with BMA Selection task has an input field for selecting the target Bare Metal Agent.
- The Setup PXE Boot task does not have an option to select the target Bare Metal Agent. This legacy workflow task uses the default Bare Metal Agent as the target Bare Metal Agent.
- The Setup Windows PXE boot task has an input field for selecting the target Bare Metal Agent.



**Tip**

For the legacy Setup PXE Boot task, the default Bare Metal Agent is the first Bare Metal Agent added. However, you can change the default Bare Metal Agent. See [Changing the Default Bare Metal Agent Account](#), on page 23.

## Prerequisites for Workflows with PXE Boot Tasks

If you plan to create orchestration workflows that include one or more of the PXE boot tasks, your Cisco UCS Director and Cisco UCS Director Bare Metal Agent environment must meet the following prerequisites:

- Cisco UCS Director has been installed and the network interface configured as described in the appropriate [Cisco UCS Director installation guide](#).
- Cisco UCS Director is reachable through a web browser and you can log in.

- Cisco UCS Director Bare Metal Agent has been installed as described in [Installing Cisco UCS Director Bare Metal Agent, on page 9](#).
- The required network/VLAN has been configured as the native, or default, VLAN on the server. For example, for a Cisco UCS server, edit the vNIC template associated with the server and choose the PXE network/VLAN as the native VLAN. You can perform this configuration through an orchestration workflow.
- Each Bare Metal Agent account that you want to use in a workflow has been set up, is active, has a tested connection, and has services that have been enabled and started.

## Execution of the Setup PXE Boot Tasks

The following Setup PXE Boot tasks are available for use in workflows:

- Setup PXE Boot task
- Setup PXE Boot with BMA Selection task
- Setup Windows PXE Boot task

Each time that one of these tasks is executed within a workflow, Cisco UCS Director uses the following values for the inputs to complete a set of configuration files for that particular PXE request:

- Dynamic values received from previous tasks in the workflow or from the user at run-time.
- Static values that you enter when you create the workflow.
- Template configuration files—the ks.cfg Kickstart files—that were created when the chosen operating system was added to Bare Metal Agent. For more information about these files, see [Sample Operating System Configuration Template Files, on page 89](#).

When the workflow is executed, Bare Metal Agent and Cisco UCS Director use the values gathered through the task and perform the following steps to prepare for a PXE installation request on the specified server:

| Step | Action                                                                                                                                                                                                                                                                                                                                                                                                                | Notes                                                                                                                                                                                                                                                                                                                                                                                                                                                            |
|------|-----------------------------------------------------------------------------------------------------------------------------------------------------------------------------------------------------------------------------------------------------------------------------------------------------------------------------------------------------------------------------------------------------------------------|------------------------------------------------------------------------------------------------------------------------------------------------------------------------------------------------------------------------------------------------------------------------------------------------------------------------------------------------------------------------------------------------------------------------------------------------------------------|
| 1    | Creates a new directory in the Cisco UCS Director Bare Metal Agent VM that corresponds to the PXE ID request in the <code>/opt/cnsaroot/web/ks-repository/</code> directory.                                                                                                                                                                                                                                          | You can view these PXE requests and PXE IDs on the <b>PXE Boot Requests</b> tab for a pod in Cisco UCS Director.                                                                                                                                                                                                                                                                                                                                                 |
| 2    | Adds the required unique configuration files to the <code>/opt/cnsaroot/web/ks-repository/PXE_ID</code> directory for the PXE installation specific to this request, including the <code>ks.cfg</code> , or Kickstart Configuration, file. Depending upon the operating system, other configuration files might be added to this directory, such as the <code>boot.cfg</code> file required for an ESXi installation. | For example, to create the customized <code>ks.cfg</code> file for the PXE installation, Cisco UCS Director takes the template <code>ks.cfg</code> file from the <code>/opt/cnsaroot/templates/Operating_System/</code> directory and fills in the variables provided in the Setup PXE Boot task. This customized <code>ks.cfg</code> file is saved in a directory that corresponds to the PXE ID, such as <code>/opt/cnsaroot/web/ks-repository/PXE_ID</code> . |

| Step | Action                                                                                                                                              | Notes                                                                                                                                                                                                                                                                                      |
|------|-----------------------------------------------------------------------------------------------------------------------------------------------------|--------------------------------------------------------------------------------------------------------------------------------------------------------------------------------------------------------------------------------------------------------------------------------------------|
| 3    | Creates a file corresponding to the MAC address of the server in the <code>/opt/cnsaroot/pxelinux.cfg/</code> directory in the Bare Metal Agent VM. | The workflow appends "01-" to the MAC address of the server to create the filename. This file includes information about where the image files are located and is generated through the <code>pxe.cfg</code> file in the <code>/opt/cnsaroot/templates/Operating_System/</code> directory. |

**Note**

Bare Metal Agent automatically creates Windows answer files for the supported operating systems. The same answer file is used for local boot and SAN boot. The Windows installation does not support multi-path SAN boot, but you can use a single path workflow to achieve SAN boot.

## Determining the Windows OS Edition

The exact Windows OS edition is required for successful PXE boot of a Windows Server image. You must enter the exact character string used by Windows PE (WinPE). This string is case sensitive. The Windows OS edition follows a consistent naming convention. Some examples of OS editions are as follows:

```
Windows Server 2008 R2 SERVERSTANDARD
Windows Server 2008 R2 SERVERSTANDARDCORE
Windows Server 2008 R2 SERVERENTERPRISE
Windows Server 2008 R2 SERVERENTERPRISECORE
Windows Server 2008 R2 SERVERDATACENTER
Windows Server 2008 R2 SERVERDATACENTERCORE
Windows Server 2008 R2 SERVERWEB
Windows Server 2008 R2 SERVERWEBCORE
Windows Server 2012 SERVERSTANDARD
Windows Server 2012 SERVERSTANDARDCORE
Windows Server 2012 R2 SERVERSTANDARD
Windows Server 2012 R2 SERVERSTANDARDCORE
Windows Server 2012 R2 SERVERDATACENTER
Windows Server 2012 R2 SERVERDATACENTERCORE
```

### Procedure

- Step 1** Navigate to the extracted ISO files for the Windows OS image.
- Step 2** For a Windows 2012 R2 image, navigate to `C:\win2k12r2\sources\install.wim` and use a PowerShell cmdlet to find the edition.
- An example of the use of this cmdlet is as follows:

```
PS C:\Windows\system32> Get-WindowsImage -ImagePath
C:\win2k12r2\sources\install.wim
Index : 1
Name : Windows Server 2012 R2 SERVERSTANDARDCORE
Description : Windows Server 2012 R2 SERVERSTANDARDCORE
Size : 6,653,342,051 bytes
Index : 2
```

```

Name : Windows Server 2012 R2 SERVERSTANDARD
Description : Windows Server 2012 R2 SERVERSTANDARD
Size : 11,807,528,410 bytes
Index : 3
Name : Windows Server 2012 R2 SERVERDATAACENTERCORE
Description : Windows Server 2012 R2 SERVERDATAACENTERCORE
Size : 6,653,031,430 bytes
<etcetera>

```

**Step 3** For a Windows 2008 image, use the DISM.EXE syntax from the computer on which you installed the WAIK tools.

An example of the use of this syntax is as follows:

```

C:\Program Files\Windows AIK\Tools\>dism
/get-wiminfo /wimfile:e:\Win2k8r2x64\sources\install.wim
Deployment Image Servicing and Management tool
Version: 6.1.7600.16385
Details for image : e:\Username_Windowsbits\Win2k8r2x64\sources\install.wim
Index : 1
Name : Windows Server 2008 R2 SERVERSTANDARD
Description : Windows Server 2008 R2 SERVERSTANDARD
Size : 10,510,503,883 bytes
Index : 2
Name : Windows Server 2008 R2 SERVERSTANDARDCORE
Description : Windows Server 2008 R2 SERVERSTANDARDCORE
Size : 3,563,695,852 bytes
<etcetera>

```

## Inputs for the Setup PXE Boot Task

The following table describes the inputs for the Setup PXE Boot task. Because the information for one or more of these inputs can be obtained from a previous task or from a user at run-time, the values for these inputs can be dynamic and change with each execution of the workflow.



### Note

For legacy Setup PXE Boot tasks, the default Bare Metal Agent is the first Bare Metal Agent added. However, you can change the default Bare Metal Agent. See [Changing the Default Bare Metal Agent Account](#), on page 23.

Table 2: Setup PXE Boot Task Inputs

| Input                                | Description                                                                                                                                                                                                                                                                                                                                                                                                                                                                                                     |
|--------------------------------------|-----------------------------------------------------------------------------------------------------------------------------------------------------------------------------------------------------------------------------------------------------------------------------------------------------------------------------------------------------------------------------------------------------------------------------------------------------------------------------------------------------------------|
| Network Boot Manager drop-down list  | <p>Choose the network boot manager that you want to use. Choose one of the following:</p> <ul style="list-style-type: none"> <li>• PXE—PXE supports only TFTP protocol</li> <li>• iPXE-BIOS—iPXE-BIOS supports HTTP protocol by default</li> <li>• iPXE-UEFI—iPXE-UEFI supports TFTP protocol by default. However, you can modify the <code>ipxe-uefi.cfg</code> to support the HTTP protocol. See <a href="#">Setting Up UEFI as Network Boot Manager</a>.</li> </ul> <p>The default option is <b>PXE</b>.</p> |
| OS Type drop-down list               | The OS image that you want this PXE or iPXE boot request to install on the server. The drop-down list includes all OS images that have been created and are available for PXE or iPXE installation.                                                                                                                                                                                                                                                                                                             |
| Server MAC Address                   | The MAC address of the server that requires the PXE or iPXE installation. This input is typically mapped to the MAC address output from the Create UCS Service Profile task.                                                                                                                                                                                                                                                                                                                                    |
| IP Configuration Type drop-down list | <p>Choose the configuration type. Choose one of the following:</p> <ul style="list-style-type: none"> <li>• Static</li> <li>• DHCP</li> </ul>                                                                                                                                                                                                                                                                                                                                                                   |
| Server IP Address field              | <p>The IP Address that you want to assign to the server. This IP address is given to the server after the PXE or iPXE installation process is complete, and is the final IP address for the server. This field is displayed only when you select the Static option in the <b>IP Configuration Type</b> drop-down list.</p> <p>This IP address can be on a different network or subnet than the PXE or iPXE network or Management network that you configured for Bare Metal Agent.</p>                          |
| Server Net Mask field                | The subnet mask that you want to assign to the server after the PXE or iPXE installation process is complete. This field is displayed only when you select the Static option in the <b>IP Configuration Type</b> drop-down list.                                                                                                                                                                                                                                                                                |
| Server Host Name field               | The hostname that you want to assign to the server after the PXE or iPXE installation process is complete.                                                                                                                                                                                                                                                                                                                                                                                                      |

| Input                           | Description                                                                                                                                                                                                                                                                                                                            |
|---------------------------------|----------------------------------------------------------------------------------------------------------------------------------------------------------------------------------------------------------------------------------------------------------------------------------------------------------------------------------------|
| <b>Server Gateway</b> field     | The default gateway IP address that you want to assign to the server after the PXE or iPXE installation process is complete. This field is displayed only when you select the Static option in the <b>IP Configuration Type</b> drop-down list.                                                                                        |
| <b>Server Name Server</b> field | (Optional) The DNS server that you want the server to use. This field is displayed only when you select the Static option in the <b>IP Configuration Type</b> drop-down list.<br><br>If no DNS server is required, leave this input blank.                                                                                             |
| <b>Management VLAN</b> field    | (Optional) The VLAN ID that you want to assign to the management interface on the server after the PXE or iPXE installation process is complete.<br><br>This setting is typically used in ESX/ESXi deployments where VLAN tagging is prevalent on the virtual switch. It sets the VLAN ID for tagging on the management vmkernel port. |
| <b>Root Password</b> field      | The password that you want to assign to the root user on the server.                                                                                                                                                                                                                                                                   |
| <b>Timezone</b> field           | The time zone in which you want to configure the server.                                                                                                                                                                                                                                                                               |

| Input                           | Description                                                                                                                                                                                                                                                                                                                                                                                                                                                                                                                                                                                                                                                                                                                                                                                                                                                                                                                                                                                                                                                                                                                                                                                                                                                                                                                                                                                                                                                                                                                                                                                                                                                                                                      |
|---------------------------------|------------------------------------------------------------------------------------------------------------------------------------------------------------------------------------------------------------------------------------------------------------------------------------------------------------------------------------------------------------------------------------------------------------------------------------------------------------------------------------------------------------------------------------------------------------------------------------------------------------------------------------------------------------------------------------------------------------------------------------------------------------------------------------------------------------------------------------------------------------------------------------------------------------------------------------------------------------------------------------------------------------------------------------------------------------------------------------------------------------------------------------------------------------------------------------------------------------------------------------------------------------------------------------------------------------------------------------------------------------------------------------------------------------------------------------------------------------------------------------------------------------------------------------------------------------------------------------------------------------------------------------------------------------------------------------------------------------------|
| Additional Parameters interface | <p>Interface to add, edit, or delete single-line parameters that are used additionally for the PXE or iPXE boot request. You can add multiple parameters using this interface.</p> <p>To add an additional parameter, click (+). In the <b>Add Additional Parameter</b> box that appears, enter the parameter name and the value for the parameter. Use the <b>Edit</b> button to modify the parameter name or its value. Use the <b>Delete</b> button to delete a parameter.</p> <p>For example, you can use an additional parameter to customize the ks.cfg file template and provide a value for the parameter here. The parameter is then updated with the appropriate value in the ks.cfg file template.</p> <p>Suppose the existing firewall configuration in ks.cfg is as follows:</p> <pre># Firewall configuration firewall --disabled</pre> <p>You can customize the configuration as following:</p> <pre># Firewall configuration firewall --\$FIREWALL_CONFIG</pre> <p>In the Additional Parameter interface here, you can include FIREWALL_CONFIG as the parameter name and provide the value as disabled. The value of the parameter can also be mapped to a user input <code>\$(variable)</code>. This parameter is updated with the appropriate value in the ks.cfg file template.</p> <p>The ks.cfg file templates used by Bare Metal Agent are available in <code>/opt/cnsaroot/templates/IMAGE_CATALOG_NAME/ks.cfg</code>. For example, the ks.cfg file for CentOS 6.0 is available in <code>/opt/cnsaroot/templates/CentOS60/ks.cfg</code></p> <p><b>Note</b> In the template files to retain dollar sign (\$) and backslash (\), you must include a backslash (\) before the character.</p> |

## Inputs for the Setup PXE Boot with BMA Selection Task

The following table describes the inputs for the Setup PXE Boot with BMA Selection task. Because the information for one or more of these inputs can be obtained from a previous task or from a user at run-time, the values for these inputs can be dynamic and change with each execution of the workflow.



### Note

The Setup PXE Boot with BMA Selection task does not support the Windows OS and does not accept inputs for that OS.



**Table 3: Setup PXE Boot with BMA Selection Task Inputs**

| Input                                       | Description                                                                                                                                                                                                                                                                                                                                                                                                                                                                                        |
|---------------------------------------------|----------------------------------------------------------------------------------------------------------------------------------------------------------------------------------------------------------------------------------------------------------------------------------------------------------------------------------------------------------------------------------------------------------------------------------------------------------------------------------------------------|
| <b>Network Boot Manager</b> drop-down list  | Choose the network boot manager that you want to use. Choose one of the following: <ul style="list-style-type: none"> <li>• PXE—PXE supports only TFTP protocol</li> <li>• iPXE-BIOS—iPXE-BIOS supports HTTP protocol by default</li> <li>• iPXE-UEFI—iPXE-UEFI supports TFTP protocol by default. However, you can modify the <code>ipxe-uefi.cfg</code> to support the HTTP protocol. See <a href="#">Setting Up UEFI as Network Boot Manager</a>.</li> </ul> The default option is <b>PXE</b> . |
| <b>Target BMA</b> field                     | The Bare Metal Agent accounts that have been added to Cisco UCS Director and are available for use.                                                                                                                                                                                                                                                                                                                                                                                                |
| <b>OS Type</b> drop-down list               | The OS image that you want this PXE or iPXE boot request to install on the server. The drop-down list includes all OS images that have been created and are available for PXE or iPXE installation.                                                                                                                                                                                                                                                                                                |
| <b>Server MAC Address</b>                   | The MAC address of the server that requires the PXE or iPXE installation. This input is typically mapped to the MAC address output from the Create UCS Service Profile task.                                                                                                                                                                                                                                                                                                                       |
| <b>IP Configuration Type</b> drop-down list | Choose the configuration type. Choose one of the following: <ul style="list-style-type: none"> <li>• Static</li> <li>• DHCP</li> </ul>                                                                                                                                                                                                                                                                                                                                                             |
| <b>Server Address</b> field                 | The IP Address that you want to assign to the server. This IP address is given to the server after the PXE or iPXE installation process is complete and is the final IP address for the server. This field is displayed only when you select the Static option in the <b>IP Configuration Type</b> drop-down list.<br><br>This IP address can be on a different network or subnet than the PXE or iPXE network or Management network that you configured for Bare Metal Agent.                     |
| <b>Server Net Mask</b> field                | The subnet mask that you want to assign to the server after the PXE or iPXE installation process is complete. This field is displayed only when you select the Static option in the <b>IP Configuration Type</b> drop-down list.                                                                                                                                                                                                                                                                   |
| <b>Server Host Name</b> field               | The hostname that you want to assign to the server after the PXE or iPXE installation process is complete.                                                                                                                                                                                                                                                                                                                                                                                         |

| Input                           | Description                                                                                                                                                                                                                                                                                                                            |
|---------------------------------|----------------------------------------------------------------------------------------------------------------------------------------------------------------------------------------------------------------------------------------------------------------------------------------------------------------------------------------|
| <b>Server Gateway</b> field     | The default gateway IP address that you want to assign to the server after the PXE or iPXE installation process is complete. This field is displayed only when you select the Static option in the <b>IP Configuration Type</b> drop-down list.                                                                                        |
| <b>Server Name Server</b> field | (Optional) The DNS server that you want the server to use. This field is displayed only when you select the Static option in the <b>IP Configuration Type</b> drop-down list.<br><br>If no DNS server is required, leave this input blank.                                                                                             |
| <b>Management VLAN</b> field    | (Optional) The VLAN ID that you want to assign to the management interface on the server after the PXE or iPXE installation process is complete.<br><br>This setting is typically used in ESX/ESXi deployments where VLAN tagging is prevalent on the virtual switch. It sets the VLAN ID for tagging on the management vmkernel port. |
| <b>Root Password</b> field      | The password that you want to assign to the root user on the server.                                                                                                                                                                                                                                                                   |
| <b>Timezone</b> field           | The time zone in which you want to configure the server.                                                                                                                                                                                                                                                                               |

| Input                                         | Description                                                                                                                                                                                                                                                                                                                                                                                                                                                                                                                                                                                                                                                                                                                                                                                                                                                                                                                                                                                                                                                                                                                                                                                                                                                                                                                                                                                                                                                                                                                                                                                                                                                                                                                                       |
|-----------------------------------------------|---------------------------------------------------------------------------------------------------------------------------------------------------------------------------------------------------------------------------------------------------------------------------------------------------------------------------------------------------------------------------------------------------------------------------------------------------------------------------------------------------------------------------------------------------------------------------------------------------------------------------------------------------------------------------------------------------------------------------------------------------------------------------------------------------------------------------------------------------------------------------------------------------------------------------------------------------------------------------------------------------------------------------------------------------------------------------------------------------------------------------------------------------------------------------------------------------------------------------------------------------------------------------------------------------------------------------------------------------------------------------------------------------------------------------------------------------------------------------------------------------------------------------------------------------------------------------------------------------------------------------------------------------------------------------------------------------------------------------------------------------|
| <p><b>Additional Parameters</b> interface</p> | <p>Interface to add, edit, or delete single-line parameters that are used additionally for the PXE or iPXE boot request. You can add multiple parameters using this interface.</p> <p>To add an additional parameter, click (+). In the <b>Add Additional Parameter</b> box that appears, enter the parameter name and the value for the parameter. Use the <b>Edit</b> button to modify the parameter name or its value. Use the <b>Delete</b> button to delete a parameter.</p> <p>For example, you can use an additional parameter to customize the ks.cfg file template and provide a value for the parameter here. The parameter is then updated with the appropriate value in the ks.cfg file template.</p> <p>Suppose the existing firewall configuration in ks.cfg is as follows:</p> <pre># Firewall configuration firewall --disabled</pre> <p>You can customize the configuration as following:</p> <pre># Firewall configuration firewall --\$FIREWALL_CONFIG</pre> <p>In the <b>Additional Parameter</b> interface here, you can include <code>FIREWALL_CONFIG</code> as the parameter name and provide the value as <code>disabled</code>. The value of the parameter can also be mapped to a user input <code>\$(variable)</code>. This parameter is updated with the appropriate value in the ks.cfg file template.</p> <p>The ks.cfg file templates used by Bare Metal Agent are available in <code>/opt/cnsaroot/templates/IMAGE_CATALOG_NAME/ks.cfg</code>. For example, the ks.cfg file for CentOS 6.0 is available in <code>/opt/cnsaroot/templates/CentOS60/ks.cfg</code></p> <p><b>Note</b> In the template files to retain dollar sign (\$) and backslash (\), you must include a backslash (\) before the character.</p> |

## Inputs for the Setup Windows PXE Boot Task

The following table describes the inputs for the Setup Windows PXE Boot task. Because the information for one or more of these inputs can be obtained from a previous task or from a user at run-time, the values for these inputs can be dynamic and change with each execution of the workflow.



### Note

Bare Metal Agent automatically creates Windows answer files for supported Windows operating systems. You can use the same answer file for local boot and SAN boot. The Windows installation does not support multi-path SAN boot, but you can use a single path workflow to achieve SAN boot.

Table 4: Setup Windows PXE Boot Task Inputs

| Input                                                        | Description                                                                                                                                                                                                                                                                                                                                                                                                                                                                                                                                                                                                                                                                                                                                 |
|--------------------------------------------------------------|---------------------------------------------------------------------------------------------------------------------------------------------------------------------------------------------------------------------------------------------------------------------------------------------------------------------------------------------------------------------------------------------------------------------------------------------------------------------------------------------------------------------------------------------------------------------------------------------------------------------------------------------------------------------------------------------------------------------------------------------|
| <b>Network Boot Manager</b><br>drop-down list                | <p>Choose the network boot manager that you want to use. Choose one of the following:</p> <ul style="list-style-type: none"> <li>• PXE—PXE supports only TFTP protocol</li> <li>• iPXE-BIOS—iPXE-BIOS supports HTTP protocol by default</li> <li>• iPXE-UEFI—iPXE-UEFI supports TFTP protocol by default. However, you can modify the <code>ipxe-uefi.cfg</code> to support the HTTP protocol. See <a href="#">Setting Up UEFI as Network Boot Manager</a>.</li> </ul> <p>The default option is <b>PXE</b>.</p>                                                                                                                                                                                                                             |
| <b>Target BMA</b> field                                      | The Bare Metal Agent accounts that have been added to Cisco UCS Director and are available for use.                                                                                                                                                                                                                                                                                                                                                                                                                                                                                                                                                                                                                                         |
| <b>OS Type</b><br>drop-down list                             | The OS image that you want this PXE boot request to install on the server. The drop-down list includes all OS images that have been created in Bare Metal Agent and are available for PXE installation.                                                                                                                                                                                                                                                                                                                                                                                                                                                                                                                                     |
| <b>Enable Hyper-V role for Windows Server 2016</b> check box | <p>Check this check box if you want to enable Hyper-V role for Windows server 2016. This field is displayed when you choose the Windows 2016(x64) option in the <b>OS Type</b> drop-down list.</p> <p><b>Note</b> If you want to enable Hyper-V on Windows 2012 and Windows 2012 R2, you should add the <code>&lt;selection name="Microsoft-Hyper-V" state="true" /&gt;</code> in the answer files available in BMA (under <code>&lt;package&gt;</code> in <code>&lt;servicing&gt;</code> node). The answers files for Windows 2012 R2 and Windows 2012 are available in <code>/opt/cnsaroot/templates/Win2k12R2x64/autounattend.xml</code> and <code>/opt/cnsaroot/templates/Win2k12x64/autounattend.xml</code> location respectively.</p> |
| <b>Server MAC Address</b>                                    | The MAC address of the server that requires the PXE installation. This input is typically mapped to the MAC address output from the Create UCS Service Profile task.                                                                                                                                                                                                                                                                                                                                                                                                                                                                                                                                                                        |
| <b>OS Flavor Name</b> field                                  | <p>The Windows OS edition name is required for successful PXE boot of a Windows Server image. You must enter the exact character string used by Windows PE (WinPE). This string is case sensitive. For example, enter SERVERSTANDARD or SERVERENTERPRISE. For more information, see <a href="#">Determining the Windows OS Edition, on page 66</a>.</p> <p>This value is used in the Windows answer file, which requires the correct name of the edition for the image installation process. The OS edition might be different for each type of Windows OS image.</p>                                                                                                                                                                       |
| <b>Organization Name</b> field                               | <p>The name of the organization that is associated with the OS product key.</p> <p>This value is used by the Windows answer file. It could be a division within your company or the company name.</p>                                                                                                                                                                                                                                                                                                                                                                                                                                                                                                                                       |
| <b>Product Key</b> field                                     | The product key (sometimes called the license key or software key) for the OS.                                                                                                                                                                                                                                                                                                                                                                                                                                                                                                                                                                                                                                                              |

| Input                                       | Description                                                                                                                                                                                                                             |
|---------------------------------------------|-----------------------------------------------------------------------------------------------------------------------------------------------------------------------------------------------------------------------------------------|
| <b>Host Name</b> field                      | The hostname that you want to assign to the server after the PXE installation process is complete. Make sure the name complies with NetBIOS name restrictions.                                                                          |
| <b>Administrator Password</b> field         | The password that you want to assign to the administrative user on the server.                                                                                                                                                          |
| <b>Confirm Password</b> field               | The password that you want to assign to the administrative user on the server.                                                                                                                                                          |
| <b>IP Configuration Type</b> drop-down list | Choose the configuration type. Choose one of the following: <ul style="list-style-type: none"> <li>• Static</li> <li>• DHCP</li> </ul>                                                                                                  |
| <b>Server Address</b> field                 | The IP Address that you want to assign to the server. This field is displayed only when you select the Static option in the <b>IP Configuration Type</b> drop-down list.                                                                |
| <b>Server Net Mask</b> field                | The subnet mask that you want to assign to the server after the PXE installation process is complete. This field is displayed only when you select the Static option in the <b>IP Configuration Type</b> drop-down list.                |
| <b>Server Gateway</b> field                 | The default gateway IP address that you want to assign to the server after the PXE installation process is complete. This field is displayed only when you select the Static option in the <b>IP Configuration Type</b> drop-down list. |
| <b>Server Name Server</b> field             | The DNS server that you want the server to use. This field is displayed only when you select the Static option in the <b>IP Configuration Type</b> drop-down list.                                                                      |
| <b>Timezone</b> field                       | The time zone in which you want to configure the server.                                                                                                                                                                                |
| <b>Disk Partition Size (GB)</b> field       | The size, in GB, of the partition designated for the OS.                                                                                                                                                                                |

| Input                              | Description                                                                                                                                                                                                                                                                                                                                                                                                                                                                                                                                                                                                                                                                                                                                                                                                                                                                                                                                                                                                                                                                                                                                                                                                                                                                                                                                   |
|------------------------------------|-----------------------------------------------------------------------------------------------------------------------------------------------------------------------------------------------------------------------------------------------------------------------------------------------------------------------------------------------------------------------------------------------------------------------------------------------------------------------------------------------------------------------------------------------------------------------------------------------------------------------------------------------------------------------------------------------------------------------------------------------------------------------------------------------------------------------------------------------------------------------------------------------------------------------------------------------------------------------------------------------------------------------------------------------------------------------------------------------------------------------------------------------------------------------------------------------------------------------------------------------------------------------------------------------------------------------------------------------|
| <b>Additional Parameters</b> field | <p>Interface to add, edit, or delete single-line parameters that are used additionally for the PXE boot request. You can add multiple parameters using this interface.</p> <p>To add a parameter, click (+). In the <b>Add Additional Parameter</b> box that appears, enter the parameter name and the value for the parameter. Use the <b>Edit</b> button to modify the parameter name or its value. Use the <b>Delete</b> button to delete a parameter.</p> <p>For example, you can use parameters to provide the minimum requirements for the Windows answer file. You can define parameters and their values to enhance the answer file to meet the requirements of your environment. These parameters are updated with the appropriate values in the Answer file template.</p> <p>The answer file templates used by Bare Metal Agent are available in the following locations:</p> <ul style="list-style-type: none"> <li>Windows 2012 R2<br/>x64—/opt/cnsaroot/templates/Win2k12R2x64/autounattend.xml</li> <li>Windows 2012<br/>x64—/opt/cnsaroot/templates/Win2k12x64/autounattend.xml</li> <li>Windows 2008 R2<br/>x64—/opt/cnsaroot/templates/Win2k8R2x64/autounattend.xml</li> </ul> <p><b>Note</b> In the template files to retain dollar sign (\$) and backslash (\), you must include a backslash (\) before the character.</p> |

## Outputs from the Setup PXE Boot Task and Setup Windows PXE Boot Task

The following table describes the outputs from both the Setup PXE Boot task and the Setup Windows PXE Boot task.

**Table 5: Setup PXE Boot and Windows PXE Boot Task Outputs**

| Input              | Description                                                               |
|--------------------|---------------------------------------------------------------------------|
| OUTPUT_PXE_BOOT_ID | The ID of the PXE boot request that was set up through the workflow task. |

## Creating a PXE Boot Request in Cisco UCS Director

### Before You Begin

Create the OS image template that you want to use for the PXE boot in Bare Metal Agent.

## Procedure

- Step 1** Choose **Administration > Physical Accounts**.
- Step 2** On the **Physical Accounts** page, click **Bare Metal Agents**.
- Step 3** Click the row for the Bare Metal Agent account in which you want to set up the PXE boot request.
- Step 4** From the **More Actions** drop-down list, click **View Details**.
- Step 5** Click **PXE Boot Requests**.
- Note** You can also create a PXE Boot Request by choosing **Physical > Compute** and navigating to the pod, in the left pane, in which you want to set up the PXE boot request.
- Step 6** Click **Add PXE Request**.
- Step 7** On the **Add PXE Boot Request** screen, complete the following fields:

| Name                                           | Description                                                                                                                                                                                                                                                                                                                                                                                                                                                                                              |
|------------------------------------------------|----------------------------------------------------------------------------------------------------------------------------------------------------------------------------------------------------------------------------------------------------------------------------------------------------------------------------------------------------------------------------------------------------------------------------------------------------------------------------------------------------------|
| <b>Network Boot Manager</b><br>drop-down list  | Choose the network boot manager that you want to use. Choose one of the following: <ul style="list-style-type: none"> <li>• PXE—PXE supports only TFTP protocol</li> <li>• iPXE-BIOS—iPXE-BIOS supports HTTP protocol by default</li> <li>• iPXE-UEFI—iPXE-UEFI supports TFTP protocol by default. However, you can modify the <code>ipxe-uefi.cfg</code> to support the HTTP protocol. See <a href="#">Setting Up UEFI as Network Boot Manager</a>.</li> </ul> <p>The default option is <b>PXE</b>.</p> |
| <b>Server MAC Address</b> field                | The MAC address of the server that requires the PXE or iPXE installation.                                                                                                                                                                                                                                                                                                                                                                                                                                |
| <b>Host Name</b> field                         | The hostname to be assigned to the server after the PXE or iPXE installation process is complete.                                                                                                                                                                                                                                                                                                                                                                                                        |
| <b>Root Password</b> field                     | The password that you want to assign to the root user on the server. You need to re-enter this password in the next field to confirm it. <p><b>Note</b> Apply your organization's guidelines for maintaining the security of this password.</p>                                                                                                                                                                                                                                                          |
| <b>PXE Request for Windows</b><br>check box    | Check this check box if the PXE boot request is for a Windows OS. After you check this check box, a set of Windows-specific fields appears in this dialog box.                                                                                                                                                                                                                                                                                                                                           |
| <b>IP Configuration Type</b><br>drop-down list | Choose the configuration type. Choose one of the following: <ul style="list-style-type: none"> <li>• Static</li> <li>• DHCP</li> </ul>                                                                                                                                                                                                                                                                                                                                                                   |
| <b>Server Address</b> field                    | The IP Address that you want to assign to the server. This field is displayed only when you select the Static option in the <b>IP Configuration Type</b> drop-down list.                                                                                                                                                                                                                                                                                                                                 |

| Name                     | Description                                                                                                                                                                                                                                                                                                                                                                                                                                                                                                                                                                                                         |
|--------------------------|---------------------------------------------------------------------------------------------------------------------------------------------------------------------------------------------------------------------------------------------------------------------------------------------------------------------------------------------------------------------------------------------------------------------------------------------------------------------------------------------------------------------------------------------------------------------------------------------------------------------|
| Server Net Mask field    | The subnet mask that you want to assign to the server after the PXE or iPXE installation process is complete. This field is displayed only when you select the Static option in the <b>IP Configuration Type</b> drop-down list.                                                                                                                                                                                                                                                                                                                                                                                    |
| Server Gateway field     | The default gateway IP address that you want to assign to the server after the PXE or iPXE installation process is complete. This field is displayed only when you select the Static option in the <b>IP Configuration Type</b> drop-down list.                                                                                                                                                                                                                                                                                                                                                                     |
| Server Name Server field | The DNS server that you want the server to use. This field is displayed only when you select the Static option in the <b>IP Configuration Type</b> drop-down list.                                                                                                                                                                                                                                                                                                                                                                                                                                                  |
| OS Type drop-down list   | <p>Choose the OS image that you want this PXE or iPXE boot request to install on the server. The drop-down list includes all OS image templates that have been created and are available for PXE or iPXE installation.</p> <p>This drop-down list displays in a different location in the dialog box, depending upon whether you check the <b>PXE Request for Windows</b> check box.</p>                                                                                                                                                                                                                            |
| Management VLAN field    | <p>(Optional) The VLAN ID that you want to assign to the management interface on the server after the PXE or iPXE installation process is complete.</p> <p>This setting is used in ESX/ESXi deployments where VLAN tagging is implemented on the virtual switch. It sets the VLAN ID for tagging on the management vmkernel port.</p>                                                                                                                                                                                                                                                                               |
| OS Flavor Name field     | <p>(Required for a Windows OS only) The Windows OS edition name is required for successful PXE or iPXE boot of a Windows Server image. You must enter the exact character string used by Windows PE (WinPE). This string is case sensitive. For example, enter SERVERSTANDARD or SERVERENTERPRISE. For more information, see <a href="#">Determining the Windows OS Edition, on page 66</a>.</p> <p>This value is used in the Windows answer file, which requires the correct name of the edition for the image installation process. The OS edition name might be different for each type of Windows OS image.</p> |
| Organization Name field  | <p>(Required for a Windows OS only) The name of the organization that is associated with the OS product key.</p> <p>This value is used by the Windows answer file. It could be a division within your company or the company name.</p>                                                                                                                                                                                                                                                                                                                                                                              |
| Product Key field        | (Required for a Windows OS only) The product key (sometimes called the license key or software key) for the OS.                                                                                                                                                                                                                                                                                                                                                                                                                                                                                                     |
| Timezone drop-down list  | Choose the time zone in which you want to configure the server.                                                                                                                                                                                                                                                                                                                                                                                                                                                                                                                                                     |



| Name                                   | Description                                                                                                                                                                                                                                                                                                                                                                                                                                                                                                                                                                                                                                                                                                                                                                                                                                                                                                                                                                                                                                                                                                                                                                                                                     |
|----------------------------------------|---------------------------------------------------------------------------------------------------------------------------------------------------------------------------------------------------------------------------------------------------------------------------------------------------------------------------------------------------------------------------------------------------------------------------------------------------------------------------------------------------------------------------------------------------------------------------------------------------------------------------------------------------------------------------------------------------------------------------------------------------------------------------------------------------------------------------------------------------------------------------------------------------------------------------------------------------------------------------------------------------------------------------------------------------------------------------------------------------------------------------------------------------------------------------------------------------------------------------------|
| <b>Disk Partition Size (GB)</b> field  | (Required for a Windows OS only) The size, in GB, of the partition designated for the OS.                                                                                                                                                                                                                                                                                                                                                                                                                                                                                                                                                                                                                                                                                                                                                                                                                                                                                                                                                                                                                                                                                                                                       |
| <b>Additional Parameters</b> interface | <p>Interface to add, edit, or delete single-line parameters that are used additionally for the PXE or iPXE boot request. You can add multiple parameters using this interface.</p> <p>To add a parameter, click (+). In the <b>Add Additional Parameter</b> box that appears, enter the parameter name and the value for the parameter. Use the <b>Edit</b> button to modify the parameter name or its value. Use the <b>Delete</b> button to delete a parameter.</p> <p>For example, for a Windows OS, you can use parameters to provide the minimum requirements for the Windows answer file. You can define parameters and their values to enhance the answer file to meet the requirements of your environment. These parameters are updated with the appropriate values in the Answer file template.</p> <p>The answer file templates used by Bare Metal Agent are available in the following locations:</p> <ul style="list-style-type: none"> <li>• Windows 2012 R2<br/>x64—/opt/cnsaroot/templates/Win2k12R2x64/autounattend.xml</li> <li>• Windows 2012<br/>x64—/opt/cnsaroot/templates/Win2k12x64/autounattend.xml</li> <li>• Windows 2008 R2<br/>x64—/opt/cnsaroot/templates/Win2k8R2x64/autounattend.xml</li> </ul> |
| <b>Server IP Address</b> field         | <p>The static IP address that you want to assign to the server. This IP address is given to the server after the PXE or iPXE installation process is complete, and is the final IP address for the server.</p> <p>This IP address can be on a different network or subnet than the PXE network or Management network that you configured for Bare Metal Agent.</p>                                                                                                                                                                                                                                                                                                                                                                                                                                                                                                                                                                                                                                                                                                                                                                                                                                                              |
| <b>Network Mask</b> field              | The subnet mask that you want to assign to the server after the PXE or iPXE installation process is complete.                                                                                                                                                                                                                                                                                                                                                                                                                                                                                                                                                                                                                                                                                                                                                                                                                                                                                                                                                                                                                                                                                                                   |
| <b>Gateway</b> field                   | The default gateway IP address that you want to assign to the server after the PXE or iPXE installation process is complete.                                                                                                                                                                                                                                                                                                                                                                                                                                                                                                                                                                                                                                                                                                                                                                                                                                                                                                                                                                                                                                                                                                    |
| <b>Server Name Server</b> field        | <p>The DNS server that you want the server to use.</p> <p>If no DNS server is required, leave this field blank.</p>                                                                                                                                                                                                                                                                                                                                                                                                                                                                                                                                                                                                                                                                                                                                                                                                                                                                                                                                                                                                                                                                                                             |
| <b>Target BMA</b> drop-down list       | Choose the Bare Metal Agent that you want to use for this PXE or iPXE boot request. The Bare Metal Agent that you choose determines which OS images are available for the PXE or iPXE boot request.                                                                                                                                                                                                                                                                                                                                                                                                                                                                                                                                                                                                                                                                                                                                                                                                                                                                                                                                                                                                                             |

**Step 8** Click **Submit**.

---

Information about the new PXE Boot Request will appear as a new row in the **PXE Boot Request**, displaying the *ID* assigned to this request. The information includes the current *Status* of this request.

**What to Do Next**

After the PXE or iPXE boot request is in the Submitted state, you must set up the PXE or iPXE environment to create the Cisco UCS Director configuration files. You can activate a PXE or iPXE boot request that has a status of Submitted by selecting it and clicking **Setup PXE Environment**.

## Viewing the PXE Request Configuration Files

### Procedure

---

**Step 1** Choose **Physical > Compute**.

**Step 2** Choose **Administration > Physical Accounts**.

**Step 3** On the **Physical Accounts** page, click **Bare Metal Agents**.

**Step 4** Click the row for the Bare Metal Agent account in which you want to set up the PXE boot request.

**Step 5** From the **More Actions** drop-down list, click **View Details**.

**Step 6** Click **PXE Boot Requests**.

**Note** You can also create a PXE Boot Request by choosing **Physical > Compute** and navigating to the pod, in the left pane, in which you want to set up the PXE boot request.

**Step 7** Click the row for the PXE boot request for which you want to view the configuration file details.

**Step 8** From the **More Actions** drop-down list, click **View Configuration Files**.

**Step 9** Choose the configuration file type from the **Select the file** drop-down list  
The **View configuration files** window displays the configuration details of the selected file for a PXE request.

---

## PXE Boot States

The following are the PXE boot states for PXE boot requests in Cisco UCS Director:

- Submitted—The PXE boot request has been submitted to Cisco UCS Director.
- Environment Setup—A Submitted PXE boot request has been transferred to Bare Metal Agent and that the environment required to perform a PXE boot is ready in Bare Metal Agent.
- In Progress—The bare metal server has communicated with Bare Metal Agent and the PXE configuration files and image files are being downloaded.
- Ready—The PXE boot process is complete. The server has booted with the newly installed operating system and Bare Metal Agent received a success notification from the server that it is ready.

- Failed—The PXE boot process started, but Bare Metal Agent did not receive a success notification from the server after the defined wait period expired.
- Archived—The PXE Request task included a rollback or delete.

## Monitor PXE Boot Setup Task

When included in an orchestration workflow, the Monitor PXE Boot task monitors a particular PXE ID request until

- The PXE boot is ready.
- The maximum number of hours specified is reached before the PXE boot is ready.

## Inputs for the Monitor PXE Boot Task

The following table describes the inputs for the Monitor PXE Boot Task:

**Table 6: Monitor PXE Boot Task Inputs**

| Input                 | Description                                                                                                |
|-----------------------|------------------------------------------------------------------------------------------------------------|
| PXE Boot Id           | The ID of the PXE boot request that you want to monitor through the workflow.                              |
| Max Wait time (Hours) | The maximum length of time, in hours, that you want the task to wait for the PXE boot request to be ready. |

## Outputs from the Monitor PXE Boot Task

The Monitor PXE Boot task has no outputs.

## Remove PXE Boot Setup Task

When included in an orchestration workflow, the Remove PXE Boot Setup task removes the directory and files that are created by the Setup PXE Boot task for a particular PXE ID request.

## Inputs for the Remove PXE Boot Setup Task

The following table describes the inputs for the Remove PXE Boot Setup Task.

**Table 7: Remove PXE Boot Setup Task Inputs**

| Input       | Description                                                                                |
|-------------|--------------------------------------------------------------------------------------------|
| PXE Boot Id | The ID of the PXE boot request for which you want to remove the setup directory and files. |

## Outputs from the Remove PXE Boot Setup Task

The Remove PXE Boot Setup task has no outputs.

## Injecting Drivers When Installing RHEL 7 or CentOS 7 on UCS Modular Servers

When you install RHEL 7 or CentOS 7 on the UCS servers, manually inject drivers through the PXE.cfg file. The PXE.cfg file is available in the following location: `/opt/cnsaroot/templates/(RHEL 7/CentOS 7 OS Catalog name)`.

The default PXE.cfg file contains the following line:

```
append initrd=images/(RHEL 7/CentOS 7 OS Catalog name)/isolinux/initrd.img ramdisk_size=9216
noapic acpi=off ip=dhcp ks=$PXE_KS_URL
ksdevice= inst.repo=http://$PXE_NATIVE_WEBSERVER/(RHEL 7/CentOS 7 OS Catalog name)
net.ifnames=0 biosdevname=0
```



### Note

Here RHEL 7/CentOS 7 OS Catalog name is the name of the OS image provided in the ISO extractor script while creating the RHEL 7 or CentOS 7 OS image template in Bare Metal Agent.

To inject the drivers, update the location of the drivers in the PXE.cfg file by updating the line as shown below:

```
append initrd=images/(RHEL 7/CentOS 7 OS Catalog name)/isolinux/initrd.img ramdisk_size=9216
noapic acpi=off ip=dhcp ks=$PXE_KS_URL
ksdevice= inst.repo=http://$PXE_NATIVE_WEBSERVER/(RHEL 7/CentOS 7 OS Catalog name)
inst.dd=http://$PXE_NATIVE_WEBSERVER/
(RHEL 7/CentOS 7 OS Catalog name)/(name of the driver disk) net.ifnames=0 biosdevname=0
```

The driver disk should be in the ISO image format and placed in the following location:

```
/opt/cnsa/images/(RHEL 7/CentOS 7 OS Catalog name)/
```



### Note

- Download the driver ISO image from the UCS Servers download page on the Cisco website.
- The parameter `inst.dd` helps load the driver images during PXE install.

# Simultaneous Provisioning of Windows Server Operating Systems

You can use Bare Metal Agent to run parallel workflows and simultaneously deploy Windows server images on multiple bare metal servers.

## Prerequisites for Simultaneous Deployment

To ensure that you can perform simultaneous deployment of Windows Server operating system images, you must perform the appropriate configuration required for the versions of the operating system that are described in the following topics, including:

- Adding the PowerShell packages to the `WinPE.wim` file
- Updating `startnet.cmd` with the IP addresses and other information required for your environment

## Bare Metal Workflows

You do not need to make any changes to your existing bare metal provisioning workflows to support simultaneous deployment of Windows server operating systems.

A PXE boot task in a workflow can only provision one server with a Windows operating system. You cannot use a single PXE boot task to provision multiple servers, but you can execute PXE boot tasks simultaneously multiple times.

## Maximum Number of Simultaneous Deployments

The maximum number of simultaneous deployments is dependent upon the bandwidth of your TFTP and PXE networks.

## Minimum Supported Level of Bare Metal Agent

Simultaneous deployment of Windows server operating systems requires a minimum of Bare Metal Agent, Release 5.4. It is not supported in earlier releases of Bare Metal Agent.

## Files and Folders Used In Simultaneous Deployment

The following files and folders are used during simultaneous deployment of Windows operating systems:

### PXElinux.cfg File

The `PXElinux.cfg` file contains the MAC addresses for each of the servers and points to the `WinPE.wim` file.

### Samba Folder

The `/samba` folder contains a folder for each of the following items. Additional information about the script and folder is provided below.

- Windows images to be deployed on the bare metal servers

- `EnRoute.ps1` script
- `as-repository` folder

### AS-Repository Folder

The `/samba/as-repository` folder contains a folder for each MAC address of the servers for which a Windows operating system is to be deployed. The PXE boot task creates and stores a separate Windows answer file for each of these servers in the appropriate MAC address folder. This folder might not be created until after the first PXE boot workflow is run.

### EnRoute.ps1 Script

The `EnRoute.ps1` script determines which Windows answer file in the `as-repository` folder belongs to the server that is being provisioned. If desired, you can customize this script. However, when you add the Bare Metal Agent to Cisco UCS Director, the script in the `as-repository` folder will revert to the default script without the customizations.

### Windows Answer File

The Windows answer file contains settings and values that are used during the deployment of a Windows operating system. This answer file is typically named `unattend.xml`. During simultaneous deployment, a separate Windows answer file is created in each MAC address folder and then sent to the server to be used during the Windows operating system setup.

When the installation is successfully completed, the name of the answer file is changed to include "Completed."

For more information, see the Microsoft TechNet article on [Understanding Answer Files](#).

## Example: Simultaneous Deployment of Windows Server Operating Systems

This example describes what actions Bare Metal Agent performs when you execute two workflows at the same time, with each workflow designed to provision a bare metal server with a Windows operating system.

The illustrations below describe how server 1 and server 2 are provisioned when the PXE tasks in the workflows are executed.

**Figure 3: Server 1 Provisioning**

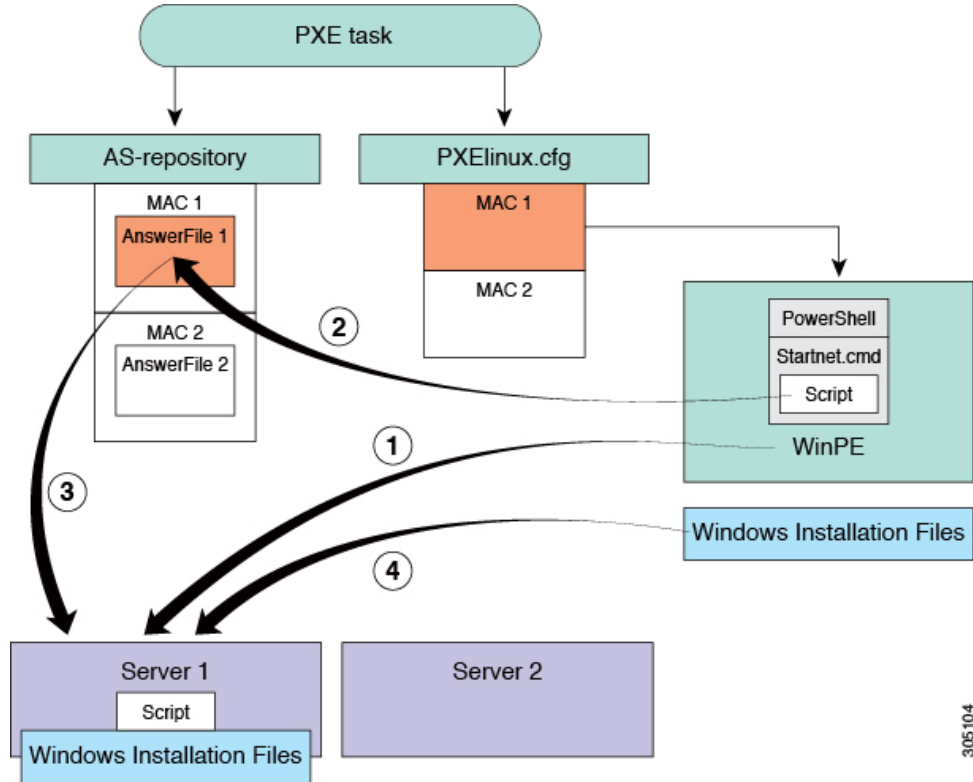

305104

When the PXE boot task is executed in the workflow that provisions Server 1, the steps shown in the above illustration occur:

| Step | Action                                                                                                                                                                                                                                                                                       |
|------|----------------------------------------------------------------------------------------------------------------------------------------------------------------------------------------------------------------------------------------------------------------------------------------------|
| 1    | Server 1 boots up. The WinPE .wim file, together with its PowerShell packages and Startnet.cmd, is copied to the server.                                                                                                                                                                     |
| 2    | The Startnet.cmd calls the EnRoute.ps1 script from the /samba folder on the Bare Metal Agent VM.<br>A folder is created under /samba/as-repository/ with MAC address of Server 1 as its name, for example, /samba/as-repository/MAC 1, and a Windows answer file is placed into that folder. |
| 3    | The EnRoute.ps1 script compares the MAC address on Server 1 with the MAC address folders available in the /samba/as-repository folder and finds the Windows answer file for Server 1 in the /samba/as-repository/MAC 1 folder.                                                               |

| Step | Action                                                                                                                                                                                                                                                         |
|------|----------------------------------------------------------------------------------------------------------------------------------------------------------------------------------------------------------------------------------------------------------------|
| 4    | Using the Windows answer file, the appropriate Windows operating system (shown as Windows installation files) is installed on Server 1.<br><br>When the installation is successfully completed, the name of the answer file is changed to include "Completed." |

Figure 4: Server 2 Provisioning

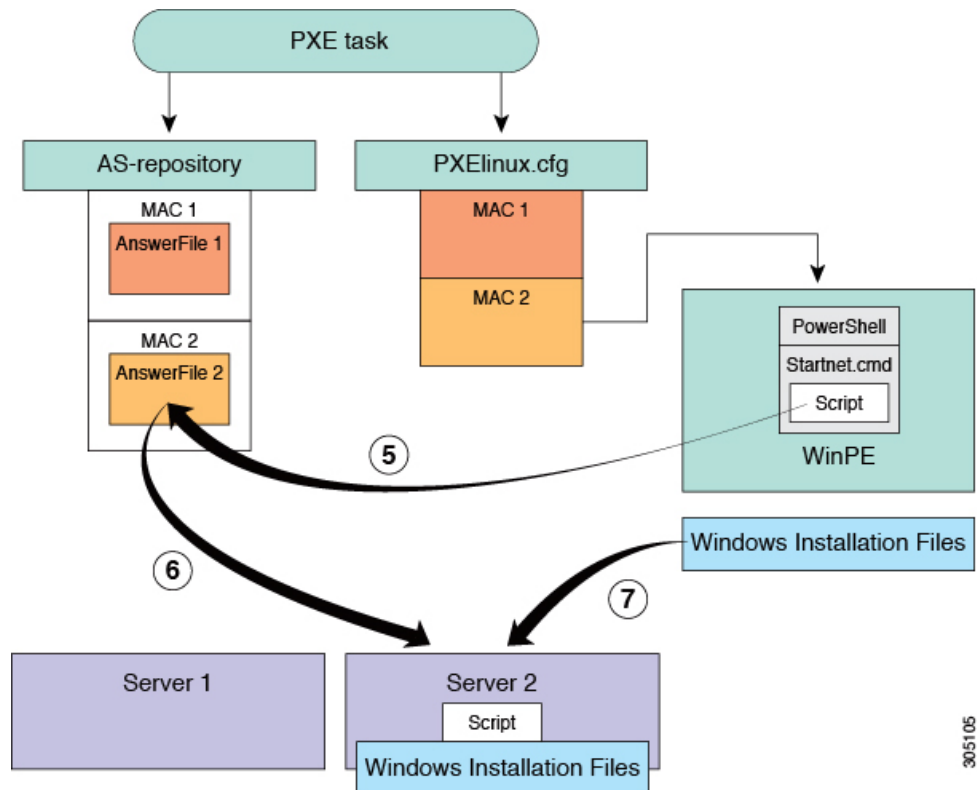

At the same time as Server 1 is being provisioned, when the PXE boot task is executed in the workflow that provisions Server 2, the steps shown in the above illustration occur:

| Step | Action                                                                                                                                                                                                                                                                                                                                                                                                                          |
|------|---------------------------------------------------------------------------------------------------------------------------------------------------------------------------------------------------------------------------------------------------------------------------------------------------------------------------------------------------------------------------------------------------------------------------------|
| 5    | Server 2 boots up. The WinPE.wim file, together with its PowerShell packages and Startnet.cmd, is copied to the server.<br><br>The Startnet.cmd calls the EnRoute.ps1 script from the /samba folder on the Bare Metal Agent VM.<br><br>A folder is created under /samba/as-repository/ with MAC address of Server 2 as its name, for example, /samba/as-repository/MAC 2, and a Windows answer file is placed into that folder. |



| Step | Action                                                                                                                                                                                                                                                                |
|------|-----------------------------------------------------------------------------------------------------------------------------------------------------------------------------------------------------------------------------------------------------------------------|
| 6    | The <code>EnRoute.ps1</code> script compares the MAC address on Server 2 with the MAC address folders available in the <code>/samba/as-repository</code> folder and finds the Windows answer file for Server 2 in the <code>/samba/as-repository/MAC 2</code> folder. |
| 7    | Using the Windows answer file, the appropriate Windows operating system (shown as Windows installation files) is installed on Server 2.<br><br>When the installation is successfully completed, the name of the answer file is changed to include "Completed."        |

Example: Simultaneous Deployment of Windows Server Operating Systems



# Sample Operating System Configuration Template Files

---

This chapter contains the following sections:

- [Sample Linux Configuration Template Files, page 89](#)
- [Sample VMware vSphere ESXi Configuration Template Files, page 91](#)
- [Sample iPXE UEFI Configuration Template File for Windows, page 93](#)
- [Sample Windows Answer File, page 93](#)

## Sample Linux Configuration Template Files

### Sample Kickstart Configuration Template File for Linux Operating Systems

The following example shows the Kickstart configuration template file (`ks.cfg`) that is required for Linux operating system images:

```
#platform=x86, AMD64, or Intel EM64T

System authorization information
auth --useshadow --enablemd5

System bootloader configuration
bootloader --append="rhgb quiet" --location=mbr --driveorder=sda

Partition clearing information
clearpart --linux --initlabel

Use text-based install
text

Firewall configuration
firewall --disabled

Run the Setup Agent on first boot
firstboot --disable

System keyboard
keyboard us
```

```

System language
lang en_US

Installation logging level
logging --level=info

Provide url/location of image over http.
url --url=http://$PXE_NATIVE_WEBSERVER/image_name

#Reboot after installation
reboot

Network information
network --bootproto=static --device=eth0 --ip=$PXE_IP
 --netmask=$PXE_NETMASK --gateway=$PXE_GATEWAY
 --hostname=$PXE_NAME --onboot=on

#Root password
rootpw $PXE_PASSWD

SELinux configuration
selinux --disabled

System timezone
timezone --utc America/New_York

Install OS instead of upgrade
install

Disk partitioning information
part / --fstype="ext3" --size=8000

#Install required packages
%packages --nobase
wget

%post
wget http://$PXE_WEBSERVER/$PXEID/notify.html

```

The following example shows the Kickstart configuration template file (`ks-uefi.cfg`) that is required for Linux operating system images:

```

auth --useshadow --enablemd5
bootloader --append="rhgb quiet" --location=mbr --driveorder=sda
clearpart --all --initlabel

zerombr
ignoredisk --only-use=sda
text
firewall --disabled
firstboot --disable
keyboard us
lang en_US
logging --level=info
url --url=http://$PXE_NATIVE_WEBSERVER/IMAGECATALOGNAME
reboot
$PXE_DHCP_IP_TYPE network --bootproto=dhcp --device=eth0 --hostname=$PXE_NAME --onboot=on
$PXE_STATIC_IP_TYPE network --bootproto=static --device=eth0 --ip=$PXE_IP
--netmask=$PXE_NETMASK --gateway=$PXE_GATEWAY --vlanid=$PXE_MGMTVLAN --hostname=$PXE_NAME
--onboot=on
rootpw $PXE_PASSWD
selinux --disabled
timezone --isUtc $PXE_TIMEZONE
install

part /boot/efi --fstype=efi --grow --maxsize=200 --size=50
part /boot --fstype=ext3 --size=500

part swap --fstype="swap" --size=1024
part pv.01 --size=10240

```

```

volgroup vg0 pv.01
logvol /home --vgname=vg0 --size=500 --name=home
logvol / --vgname=vg0 --grow --size=1 --name=root

%packages --nobase
wget
%end

%post
Notifying back to Cisco UCS Director once the blade is up
wget http://$PXE_WEBSEVER/$PXEID/notify.html
%end

```

## Sample PXE Configuration Template File for Linux Operating Systems

The following example shows the PXE configuration template file (`pxe.cfg`) that is required for Linux operating system images:

```

default linux

label linux
kernel vmlinuz

append initrd=initrd.img ramdisk_size=9216 noapic acpi=off ip=dhcp ks=$PXE_KS_URL

prompt 0
timeout 0

```

## Sample iPXE Configuration Template File for Linux Operating Systems

The following example shows the iPXE configuration template file (`ipxe.cfg`) that is required for Linux operating system images:

```

default linux
label linux
kernel http://$PXE_NATIVE_WEBSEVER/$PXE_OS/isolinux/vmlinuz
append initrd=http://$PXE_NATIVE_WEBSEVER/$PXE_OS/isolinux/initrd.img ramdisk_size=9216
noapic acpi=off ip=dhcp ks=$PXE_KS_URL ksdevice=eth0
inst.repo=http://$PXE_NATIVE_WEBSEVER/$PXE_OS net.ifnames=0 biosdevname=0
prompt 0
timeout 0

```

## Sample VMware vSphere ESXi Configuration Template Files

### Sample Kickstart Configuration Template File for VMware vSphere ESXi Operating Systems

The following example shows the Kickstart configuration template file (`ks.cfg`) that is required for VMware vSphere ESXi operating system images:

```

vmaccepteula

#Set password for ESXi server, "$PXE_PASSWD" will be filled in by UCSD
rootpw $PXE_PASSWD

```

```

#For Local boot, uncomment the following line
#install --firstdisk --overwritevmfs

#For SAN boot, uncomment the following line
install --firstdisk=remote --overwritevmfs

#Configures the mangement vmknic interface for the ESXi host. All items
 starting with "$" are variables that will be replaced by UCSD during the
 PXE boot process.
network --bootproto=static --ip=$PXE_IP --netmask=$PXE_NETMASK
 --gateway=$PXE_GATEWAY --vlanid=$PXE_MGMTVLAN
 --nameserver=$PXE_NS --hostname=$PXE_NAME

%pre --interpreter=busybox
hwclock -d %LIVE_VAR_DATE_1% -t %LIVE_VAR_TIME_UTC_1%
date -s %LIVE_VAR_DATE_TIME_UTC_1%
cd /tmp
wget http://$PXE_WEBSERVER/$PXEID/web/track/log1

%firstboot --interpreter=busybox
cd /tmp
wget http://$PXE_WEBSERVER_MGMT_VLAN_IP/$PXEID/web/track/log3

wget http://$PXE_WEBSERVER_MGMT_VLAN_IP/$PXEID/web/track/log4

#Enable & start remote ESXi Shell (SSH)
vim-cmd hostsvc/enable_ssh
vim-cmd hostsvc/start_ssh

#Enable & start ESXi Shell (TSM)
vim-cmd hostsvc/enable_esx_shell
vim-cmd hostsvc/start_esx_shell

wget http://$PXE_WEBSERVER_MGMT_VLAN_IP/$PXEID/web/track/log5

%post --interpreter=busybox --ignorefailure=true

cd /tmp
localcli network firewall set --default-action true
localcli network firewall set --enabled false
wget http://$PXE_WEBSERVER_MGMT_VLAN_IP/$PXEID/web/track/log2
wget http://$PXE_WEBSERVER_MGMT_VLAN_IP/$PXEID/notify.html -O /tmp/notify.html
localcli network firewall set --default-action false
localcli network firewall set --enabled true

#Power down the ESXi server after installation
poweroff

```

## Sample PXE Configuration Template File for VMware vSphere ESXi Operating Systems

The following example shows the PXE configuration template file (`pxe.cfg`) that is required for VMware vSphere ESXi operating system images:

```

default image_name/menu.c32
menu title PXE Boot Home
timeout 70

label image_name
menu label Install VMware image_name
kernel image_name/mboot.c32
append -c /web/ks-repository/$PXE_ID/boot.cfg ++
IPAPPEND 1

```

## Sample iPXE Configuration Template File for VMware vSphere ESXi Operating Systems

The following example shows the iPXE configuration template file (`ipxe.cfg`) that is required for VMware vSphere ESXi operating system images:

```
default 1
timeout 100
prompt 1
label 1
KERNEL ipxe.lkrn
Append dhcp && chain http://$PXENATIVE_WEBSERVER/$PXEWINDOWS_OS_REPOSITORY_LINK/boot.ipxe
```

## Sample iPXE UEFI Configuration Template File for Windows

The following example shows the iPXE UEFI configuration template file (`ipxe-uefi.cfg`) that is required for windows:

```
#!ipxe
kernel ../wimboot
initrd ../Boot/BCD BCD
initrd ../Boot/boot.sdi boot.sdi
initrd ../Boot/WinPE.wim WinPE.wim
boot
```

## Sample Windows Answer File

The following is an example of a Windows answer file, named `AUTOUNATTEND.XML`, that can be used to set up a Windows Server 2008 R2 OS image for use with Cisco UCS Director Bare Metal Agent.

```
<unattend>
 <servicing>
 <package action="configure">
 <assemblyIdentity name="Microsoft-Windows-Foundation-Package" version="6.1.7600.16385"
 processorArchitecture="amd64" publicKeyToken="xxx3856ad364xxx" language=""/>
 <selection name="IIS-WebServerRole" state="false"/>
 <selection name="IIS-WebServer" state="false"/>
 <selection name="Microsoft-Hyper-V" state="true"/>
 <selection name="Microsoft-Hyper-V-Management-Clients" state="true"/>
 <selection name="Microsoft-Hyper-V-Management-Clients" state="true"/>
 <selection name="MultipathIo" state="true"/>
 <selection name="TelnetClient" state="true"/>
 </package>
 </servicing>
 <settings pass="windowsPE">
 <component name="Microsoft-Windows-Setup" processorArchitecture="amd64"
 publicKeyToken="xxx3856ad364xxx" language="neutral" versionScope="nonSxS">
 <ComplianceCheck>
 <DisplayReport>OnError</DisplayReport>
 </ComplianceCheck>
 </component>
 </settings>
 <Display>
 <VerticalResolution>600</VerticalResolution>
 <RefreshRate>60</RefreshRate>
 <HorizontalResolution>800</HorizontalResolution>
 <ColorDepth>32</ColorDepth>
 </Display>
```

```

 <EnableFirewall>>false</EnableFirewall>
 <UserData>
 <ProductKey>
 <WillShowUI>Never</WillShowUI>
 <Key>XXXXX-XXXXX-KQT8W-PMXWJ-XXXXX</Key>
 </ProductKey>
 <AcceptEula>>true</AcceptEula>
 <FullName>Cisco</FullName>
 <Organization>CiscoUCSD</Organization>
 </UserData>
 <DiskConfiguration>
 <WillShowUI>OnError</WillShowUI>
 <Disk wcm:action="add">
 <CreatePartitions>
 <CreatePartition wcm:action="add">
 <Order>1</Order>
 <Type>Primary</Type>
 <Size>40000</Size>
 </CreatePartition>
 </CreatePartitions>
 <DiskID>0</DiskID>
 <WillWipeDisk>>true</WillWipeDisk>
 <ModifyPartitions>
 <ModifyPartition wcm:action="add">
 <Active>>true</Active>
 <Extend>>false</Extend>
 <Format>NTFS</Format>
 <Label>OS</Label>
 <Letter>C</Letter>
 <Order>1</Order>
 <PartitionID>1</PartitionID>
 </ModifyPartition>
 </ModifyPartitions>
 </Disk>
</DiskConfiguration>
<ImageInstall>
 <OSImage>
 <InstallTo>
 <DiskID>0</DiskID>
 <PartitionID>1</PartitionID>
 </InstallTo>
 <WillShowUI>Never</WillShowUI>
 <InstallFrom>
 <MetaData wcm:action="add">
 <Key>/IMAGE/NAME</Key>
 <Value>Windows Server 2008 R2 SERVERDATACENTER</Value>
 </MetaData>
 <Path>\\000.00.90.31\bits\sources\install.wim</Path>
 </InstallFrom>
</OSImage>
</ImageInstall>
</component>
<component name="Microsoft-Windows-International-Core-WinPE" processorArchitecture="amd64"
 publicKeyToken="nnnf3856ad364nnn" language="neutral" versionScope="nonSxS">
 <SetupUILanguage>
 <UILanguage>en-US</UILanguage>
 </SetupUILanguage>
 <UserLocale>en-US</UserLocale>
 <UILanguage>en-US</UILanguage>
 <SystemLocale>en-US</SystemLocale>
</component>
</settings>
<settings pass="specialize">
 <component name="Microsoft-Windows-International-Core" processorArchitecture="amd64"
 publicKeyToken="nnnf3856ad364nnn" language="neutral" versionScope="nonSxS">
 <SystemLocale>en-US</SystemLocale>
 <UILanguage>en-US</UILanguage>
 <UILanguageFallback>en-US</UILanguageFallback>
 <UserLocale>en-US</UserLocale>
 </component>
 <component name="Microsoft-Windows-TerminalServices-LocalSessionManager"
 processorArchitecture="amd64" publicKeyToken="nnnf3856ad364nnn">

```



```

 language="neutral" versionScope="nonSxS">
 <fDenyTSConnections>false</fDenyTSConnections>
 </component>
<component name="Microsoft-Windows-Deployment" processorArchitecture="amd64"
 publicKeyToken="31bf3856ad364nnn" language="neutral" versionScope="nonSxS">
<RunSynchronous>
<RunSynchronousCommand wcm:action="add">
 <Description>Disable IPv6</Description>
 <Path>reg add HKLM\SYSTEM\CurrentControlSet\Services\tcpip6\Parameters /v DisabledComponents
 /t
 REG_DWORD /d 255 /f</Path>
 <Order>1</Order>
</RunSynchronousCommand>
<RunSynchronousCommand wcm:action="add">
 <Description>Disable Shutdown Tracker</Description>
 <Path>reg add "HKLM\SOFTWARE\Policies\Microsoft\Windows NT\Reliability" /v ShutdownReasonOn
 /t
 REG_DWORD /d 0 /f</Path>
 <Order>2</Order>
</RunSynchronousCommand>
</RunSynchronous>
</component>
<component name="Networking-MPSSVC-Svc" processorArchitecture="amd64"
 publicKeyToken="nnnf3856ad364nnn" language="neutral" versionScope="nonSxS">
 <DomainProfile_EnableFirewall>false</DomainProfile_EnableFirewall>
 <PrivateProfile_EnableFirewall>false</PrivateProfile_EnableFirewall>
 <PublicProfile_EnableFirewall>false</PublicProfile_EnableFirewall>
</component>
<component name="Microsoft-Windows-ServerManager-SvrMgrNc" processorArchitecture="amd64"
 publicKeyToken="nnnf3856ad364nnn" language="neutral" versionScope="nonSxS">
 <DoNotOpenServerManagerAtLogon>true</DoNotOpenServerManagerAtLogon>
</component>
<component name="Microsoft-Windows-OutOfBoxExperience" processorArchitecture="amd64"
 publicKeyToken="nnnf3856ad364nnn" language="neutral" versionScope="nonSxS">
 <DoNotOpenInitialConfigurationTasksAtLogon>true</DoNotOpenInitialConfigurationTasksAtLogon>
</component>
<component name="Microsoft-Windows-powercpl" processorArchitecture="amd64"
 publicKeyToken="nnnf3856ad364nnn" language="neutral" versionScope="nonSxS">
 <PreferredPlan>8c5e7fda-e8bf-4a96-9a85-a6e23a8c635c</PreferredPlan>
</component>
<component name="Microsoft-Windows-Shell-Setup" processorArchitecture="amd64"
 publicKeyToken="nnnf3856ad364nnn" language="neutral" versionScope="nonSxS">
 <ComputerName>*</ComputerName>
 <ProductKey>XXXXX-XXXXX-KQT8W-PMXWJ-XXXXX</ProductKey>
</component>
</settings>
<settings pass="oobeSystem">
<component name="Microsoft-Windows-Shell-Setup" processorArchitecture="amd64"
 publicKeyToken="nnnf3856ad364nnn" language="neutral" versionScope="nonSxS">
<Display>
 <ColorDepth>32</ColorDepth>
 <HorizontalResolution>800</HorizontalResolution>
 <VerticalResolution>600</VerticalResolution>
 <RefreshRate>60</RefreshRate>
</Display>
</OOBE>
 <HideEULAPage>true</HideEULAPage>
 <HideWirelessSetupInOOBE>true</HideWirelessSetupInOOBE>
 <NetworkLocation>Work</NetworkLocation>
 <ProtectYourPC>3</ProtectYourPC>
</OOBE>
<VisualEffects>
 <FontSmoothing>ClearType</FontSmoothing>
</VisualEffects>
<WindowsFeatures>
 <ShowInternetExplorer>true</ShowInternetExplorer>
</WindowsFeatures>
 <TimeZone>Pacific Standard Time</TimeZone>
 <RegisteredOrganization/>
 <ShowWindowsLive>false</ShowWindowsLive>
</UserAccounts>
<AdministratorPassword>

```

```

 <Value>987654321abc??=</Value>
 <PlainText>>false</PlainText>
 </AdministratorPassword>
</UserAccounts>
<AutoLogon>
<Password>
 <Value>123456abc??=</Value>
 <PlainText>>false</PlainText>
</Password>
<Enabled>>true</Enabled>
<LogonCount>1</LogonCount>
<Username>Administrator</Username>
</AutoLogon>
<FirstLogonCommands>
<SynchronousCommand wcm:action="add">
 <CommandLine>cmd /c winrm quickconfig -quiet -transport:HTTP</CommandLine>
 <Description>Enable WinRS over HTTP to communicate with CPA</Description>
 <Order>1</Order>
 <RequiresUserInput>>false</RequiresUserInput>
</SynchronousCommand>
<SynchronousCommand wcm:action="add">
 <CommandLine>cmd /c winrm set winrm/config/client @{TrustedHosts="*"</CommandLine>
 <Description>Adding trusted hosts value for winrm client</Description>
 <Order>2</Order>
 <RequiresUserInput>>false</RequiresUserInput>
</SynchronousCommand>
<SynchronousCommand wcm:action="add">
 <CommandLine>cmd /c net use R: \\000.00.90.31\bits /user:smbuser cisco123</CommandLine>
 <Description>Mapping the share to save the notification file</Description>
 <Order>3</Order>
 <RequiresUserInput>>false</RequiresUserInput>
</SynchronousCommand>
<SynchronousCommand wcm:action="add">
 <CommandLine>cmd /c ipconfig /all | findstr "Physical" >>
R:\notifications\completed.html</CommandLine>
 <Description>Writing the completed notification log with MAC address at
 Share mapped in previous step</Description>
 <Order>4</Order>
 <RequiresUserInput>>false</RequiresUserInput>
</SynchronousCommand>
<SynchronousCommand wcm:action="add">
 <CommandLine>cmd /c R:\notifications\completed.bat</CommandLine>
 <Description>executing powershell batch file like as wget</Description>
 <Order>5</Order>
 <RequiresUserInput>>false</RequiresUserInput>
</SynchronousCommand>
</FirstLogonCommands>
</component>
</settings>
<settings pass="offlineServicing">
<component name="Microsoft-Windows-LUA-Settings" processorArchitecture="amd64"
 publicKeyToken="nnnf3856ad364nnn" language="neutral" versionScope="nonSxS">
 <EnableLUA>>false</EnableLUA>
</component>
</settings>
<cpu:offlineImage cpu:source="wim:D:/win2k8r2x64sp1/sources/install.wim#Windows
 Server 2008 R2 SERVERDATACENTER"/>
</unattend>

```



## Ports

---

This appendix contains the following sections:

- [Cisco UCS Director TCP and UDP Port Usage, page 97](#)
- [Port List, page 99](#)
- [Multi-Node Port Requirements, page 101](#)

### Cisco UCS Director TCP and UDP Port Usage

This section provides a list of the TCP and UDP ports that Cisco UCS Director uses for connections and communications with external applications or devices. The port usage depends upon whether you have deployed Cisco UCS Director on VMware vSphere or Microsoft Hyper-V.

## Cisco UCS Director TCP and UDP Port Usage on VMware vSphere

The following figure shows the network ports used for communication between the Cisco UCS Director appliance and managed devices, ESX servers, Bare Metal Agent, PowerShell Agent, NTP, and Active Directory for an installation on VMware vSphere.

**Figure 5: Cisco UCS Director TCP and UDP Port Usage**

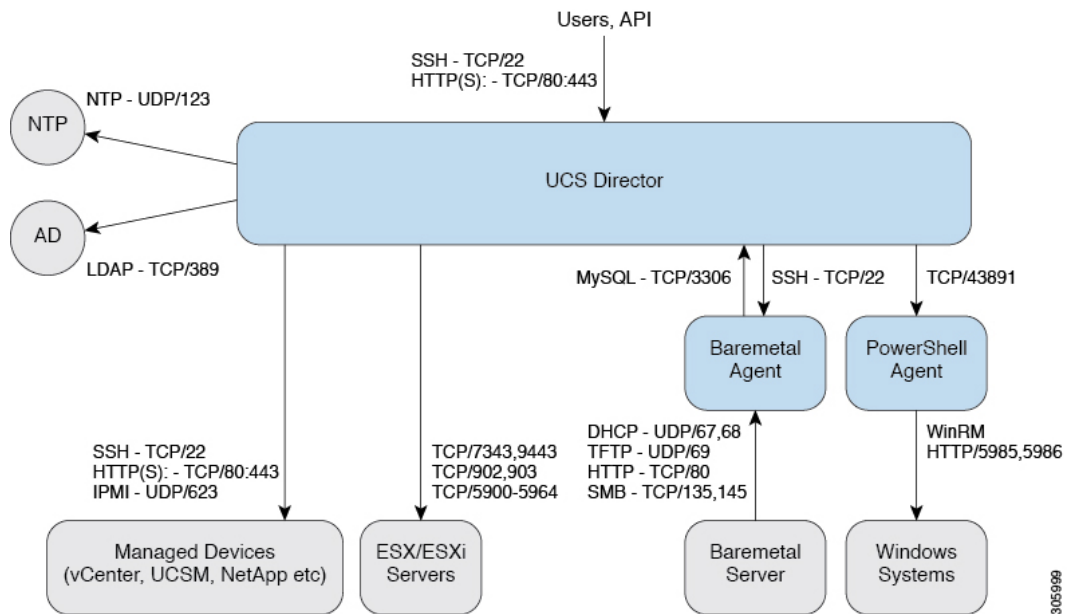

## Cisco UCS Director TCP and UDP Port Usage on Microsoft Hyper-V

The following figure shows the network ports used for communication between the Cisco UCS Director appliance and managed devices, ESX servers, Bare Metal Agent, PowerShell Agent, NTP, and Active Directory for an installation on Microsoft Hyper-V.

**Figure 6: Cisco UCS Director TCP and UDP Port Usage**

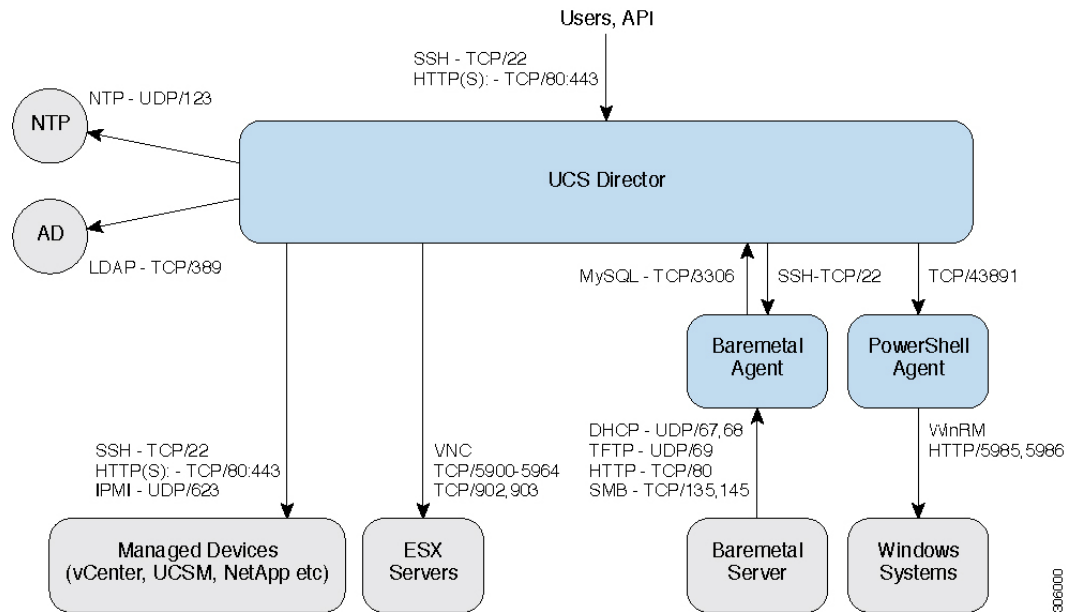

## Port List

Default Port	Protocol	Description
22	TCP	SSH
80	TCP/UDP	HTTP
8888	TCP	HTTP for Cisco UCS Director Bare Metal Agent
69	TFTP	TFTP for Cisco UCS Director Bare Metal Agent
443	UDP	HTTPS
27000/7279/8082 (Mgmt)	TCP	Citrix licensing
2598/1494/2112/2513	TCP	Virtual Desktop Agent for Desktops
67/68	UDP	DHCP

Default Port	Protocol	Description
389/636 3268/3269	TCP/UDP TCP	Active Directory
53	TCP/UDP	DNS
123	TCP/UDP	NTP
3306	TCP/UDP	MySQL
8787/5900-5964	TCP	Cisco UCS Director + VNC Connectivity
3389	TCP/UDP	Cisco UCS Director + RDP Connectivity
80/443/8080	TCP/UDP	Cisco UCS Director + NetApp Connectivity
80/443	UDP	Cisco UCS Director + Cisco UCS Manager Connectivity
80/443	UDP	Cisco UCS Director + vCenter Connectivity
3389	TCP/UDP	RDP
135/445	TCP	SMB/RPC
88	TCP/UDP	Kerberos
137	TCP/UDP	NetBIOS Name (nbname)
138	TCP/UDP	NetBIOS datagram (nbdatagram)
139	TCP	NetBIOS session (nbsession)
80/443	UDP	Desktop Delivery Controller <--> vCenter
8080 through ICA	TCP	Desktop Delivery Controller <--> Virtual Desktops
1494/2598/2512/2513	TCP	Users (Citrix Recvr) <--> Virtual Desktops
389/636 (LDAP Ports)	TCP/UDP	Desktop Delivery Controller <--> Active Directory
389/636, 3268/3269, 53	TCP/UDP	Virtual Desktops <--> Active Directory + DNS
5985/5986	TCP	PowerShell Agent <--> Xendesktop through WinRM
43891	TCP/UDP	Cisco UCS Director <--> PowerShell Agent
80/8081	TCP	XenApp

Default Port	Protocol	Description
902	TCP	VMwareESXi host management and VM customization and to execute VIX tasks
903	TCP	VMwareESXi host management and VM customization and to execute VIX tasks (for VMware vCenter releases prior to 5.0)

## Multi-Node Port Requirements

The ports listed in [Cisco UCS Director TCP and UDP Port Usage, on page 97](#) are applicable for both single and multi-node setups.

For a multi-node setup, the following ports must be opened between the nodes:

- From the primary and service nodes to database nodes: port 3306
- From the primary node to service nodes: ports 80 and 443

